

Removing internal assemblies

Fuser

WARNING!

Let the fuser assembly cool before removal.

- 1 If a duplexer is installed, remove it. If a duplexer is not installed, remove the tray 2 dust cover from the rear of the printer by pulling from the bottom.
- 2 Remove the rear cover/rear output bin (page 145).

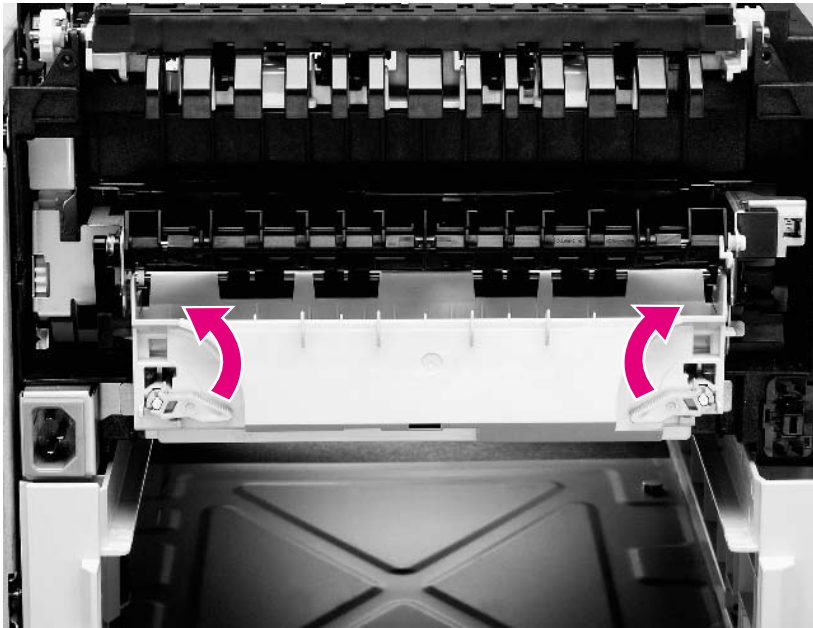

Figure 53. Unlocking the fuser assembly

- 3 Rotate the two blue levers on the fuser assembly up to the unlocked position.
- 4 Pull the fuser assembly straight out of the printer.

CAUTION

To prevent damage to the fuser assembly, do not grasp the fuser by the black plastic diverter.

Hint

When reinstalling the fuser assembly, be sure the blue levers are initially in the unlocked position. Make sure the fuser assembly is seated fully before rotating the blue levers down into the locked position.

Transfer roller

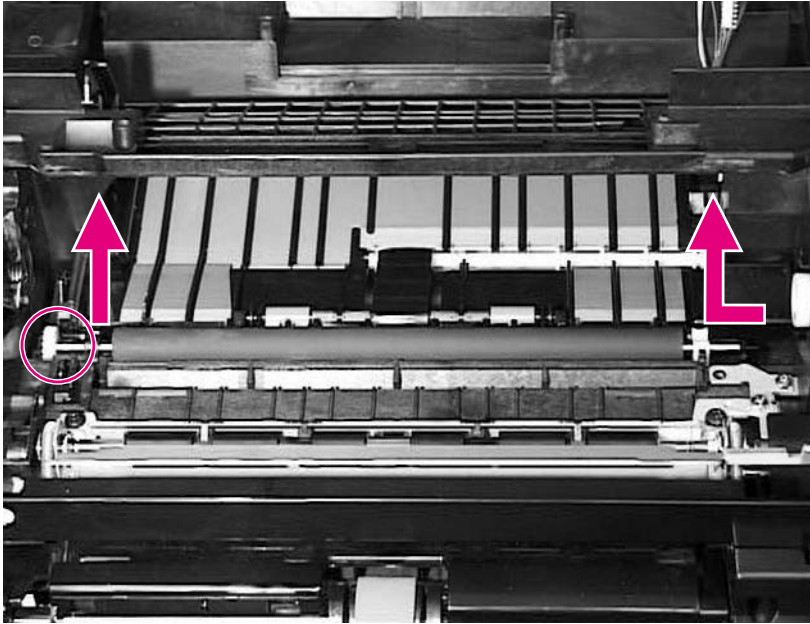

Figure 63. Removing the transfer roller

CAUTION

Do not remove the toner cartridge when the top cover interlock is overridden. Cartridge memory will be damaged.

CAUTION

To prevent damage to the toner cartridge, do not expose it to light for more than a few minutes.

- 1 Open the top cover and remove the toner cartridge. The transfer roller is underneath the toner cartridge.

CAUTION

Do not touch the black rubber part of the roller. Skin oils on the roller can cause problems with print quality. Use of gloves is recommended.

- 2 Using a flat-blade screwdriver, lift the left end of the metal shaft out of place near the blue gear. Slide the transfer roller to the left to remove.

Hint

When you install the transfer roller, make sure the black collar on the left side is oriented properly, with the open end down.

Tray 1 pickup assembly

- 1 To remove the tray 1 pickup assembly:
 - a Remove the rear right side cover (page 138).
 - b Remove the control panel (page 139).
 - c Remove the top cover (page 141).
 - d Remove the left side cover (page 143).
 - e Remove the front right side cover (page 144).
 - f Remove tray 1 (page 146).

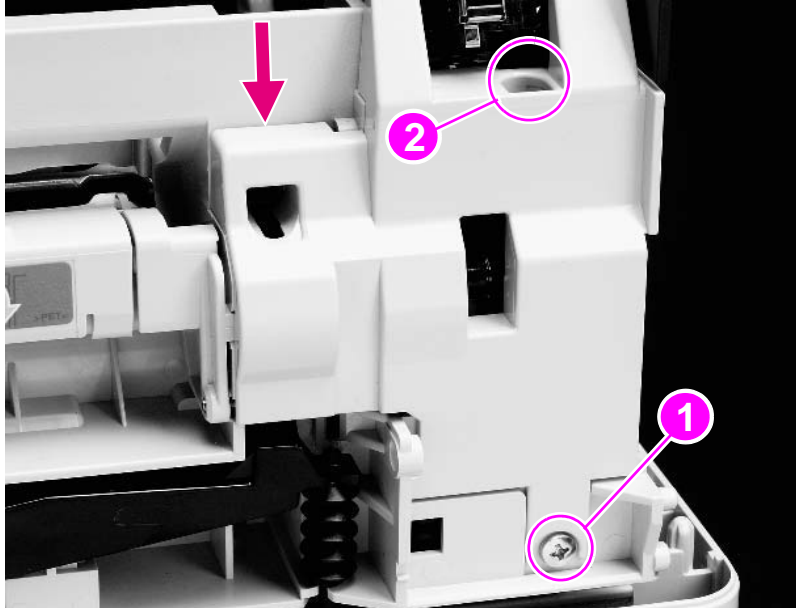

Figure 66.

Removing the gear cover

- 2 Remove the gear cover as follows:
 - a. Remove the self-tapping screw (callout 1) at the bottom of the gear cover.
 - b. Remove the long screw (116 mm/4.8 inches) on the right side of the tray 1 pickup assembly (callout 2).
 - c. Remove the gear cover by pressing down on the claw.

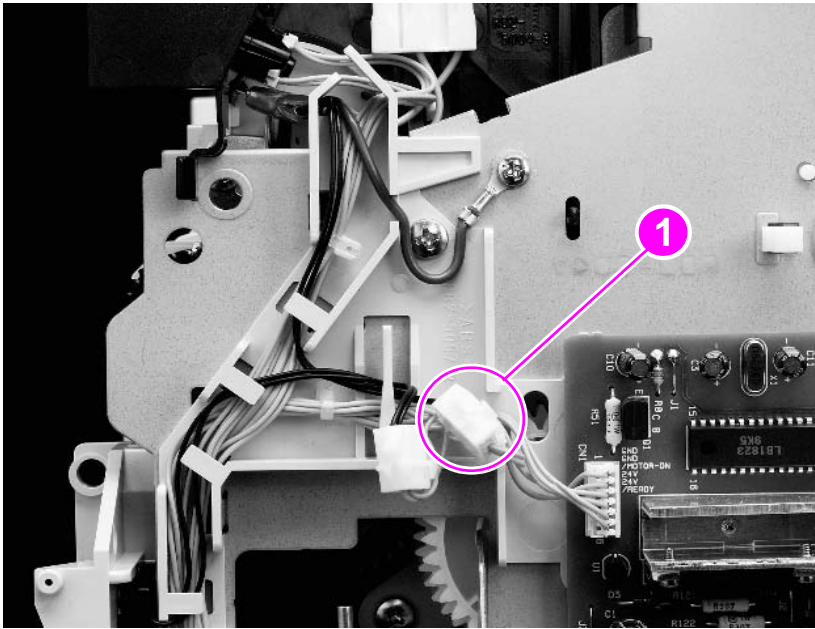

Figure 67. Removing the tray 1 pickup assembly—right side

- 3 Disconnect the three-pin solenoid connector (callout 1) on the right side of the tray 1 pickup assembly and unrout the cable from the cable guide. (Note the way the cables are routed for replacement.)

Note

The solenoid connector is a three-part connector. Do not lose the gender-changer (center piece).

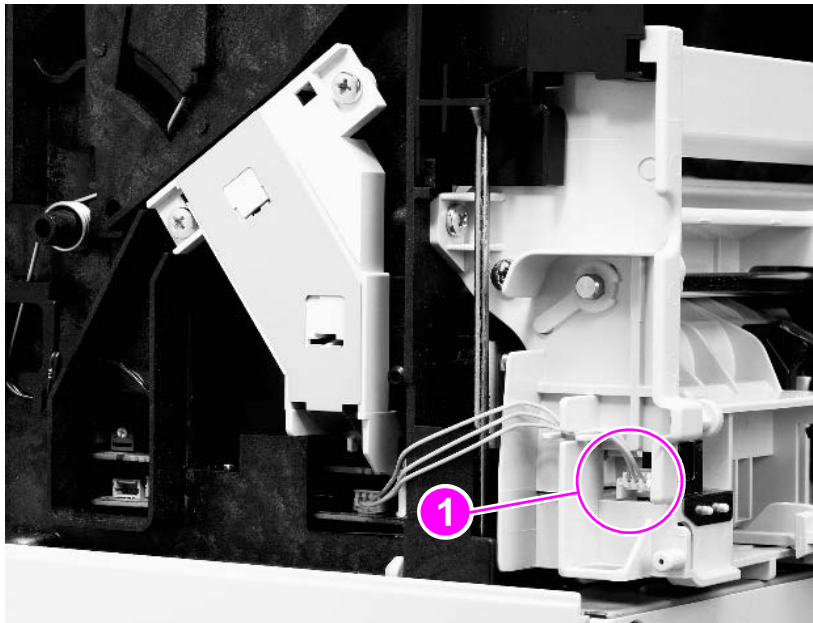

Figure 68. Removing the tray 1 pickup assembly—left side

- 4 Unplug the connector (callout 1) to the engine controller board on the left side of the tray 1 pickup assembly. (Note the way the cables are routed for replacement.)
- 5 Remove the long screw (116 mm/4.8 inches) from the left side of the assembly.

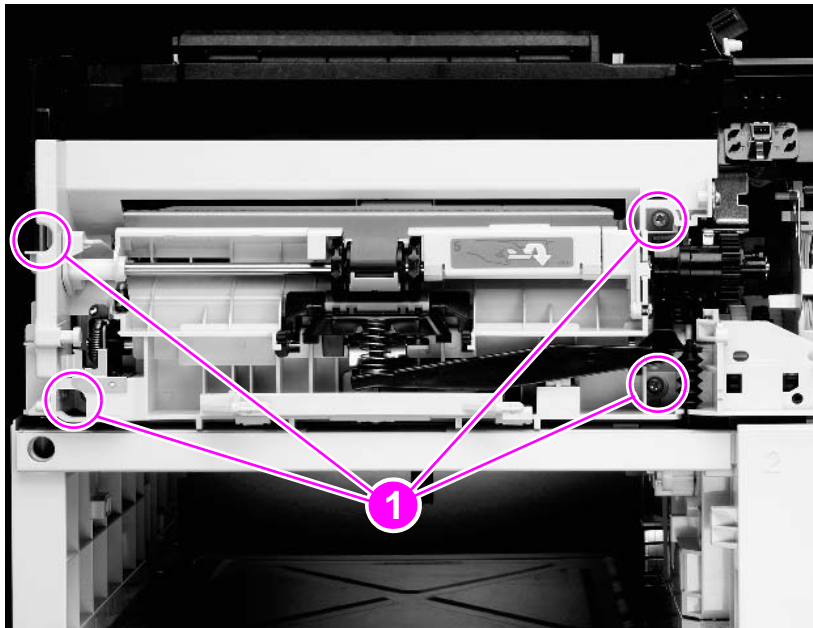

Figure 69. Removing the tray 1 pickup assembly—front side

- 6 Remove the four screws (callout 1) shown, and carefully pull the tray 1 pickup assembly straight out.

CAUTION

Do not damage the solenoid cable on the right side of the tray 1 pickup assembly.

Note

The left side toner cartridge might become dislodged while removing the tray 1 pickup assembly. Ensure the left side toner cartridge guide is installed before reinstalling the four screws that secure the tray 1 pickup assembly.

Tray 1 pickup roller

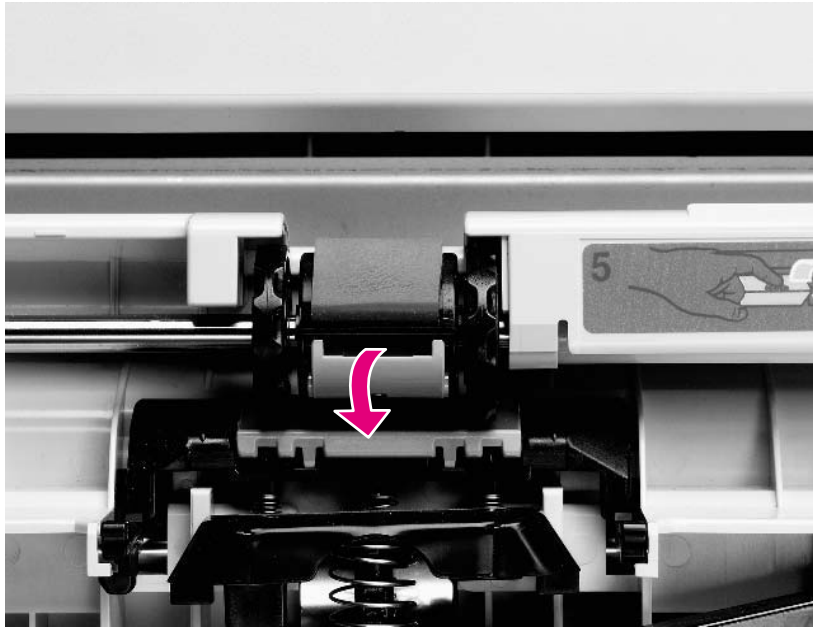

Figure 64. Removing the pickup roller (shown with envelope entrance cover removed)

- 1 Open tray 1. The tray 1 pickup roller is in the center of the tray 1 pickup assembly.
- 2 Grasp the envelope entrance cover directly above the pickup roller and pull it straight away from the printer.
- 3 Use a flat-blade screwdriver to pry open the blue latch on the roller.
- 4 Lift the roller out.

Hint To replace the roller, make sure the pin in the roller lines up with the hole in the shaft. Then, ensure the blue latch snaps securely in place.

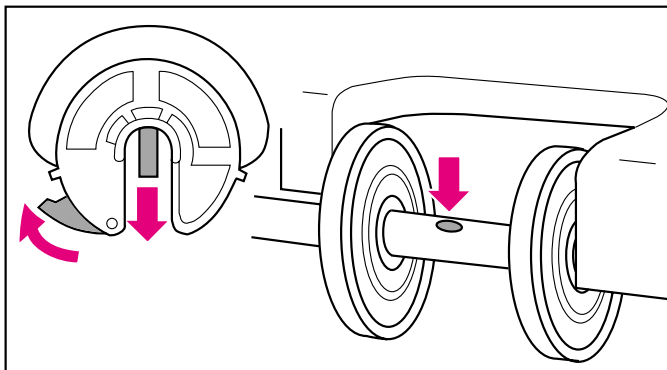

Figure 65. Installation of tray 1 pickup roller