

Fuser



WARNING! The fuser might be very hot. After turning off the printer power, allow the fuser to cool for at least 30 minutes before removing it.

- 1 Remove the rear output bin. See [Rear output bin](#).
- 2 Squeeze the blue fuser-release tabs (callout 1).
- 3 Pull the fuser (callout 2) straight back and out of the printer.

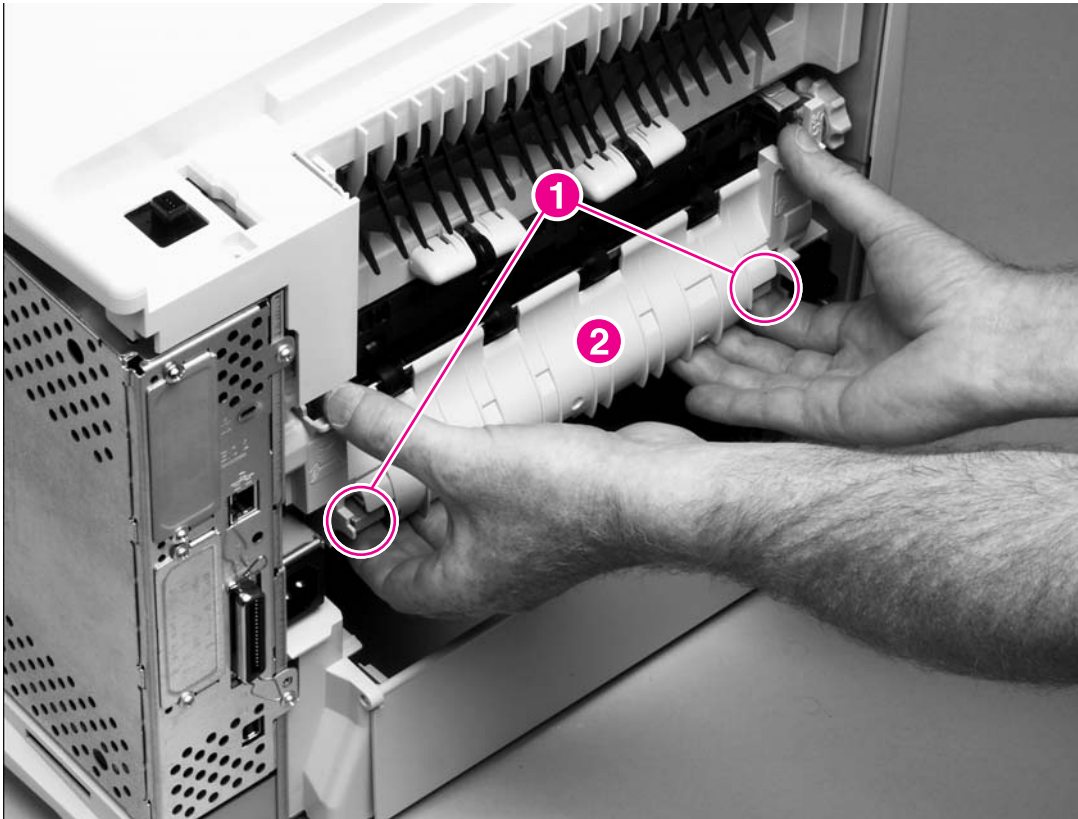

Figure 6-6 Fuser



CAUTION Do not drop or jar the fuser. It can easily be damaged if it is mishandled.



Hint When you replace the fuser, make sure that it is fully seated into the printer. You should hear both sides snap into place.

Transfer roller

- 1 Open the control-panel door and tray 1.

 **CAUTION** Do not touch the black rubber on the roller. Skin oils on the roller can cause print-quality problems. The use of disposable gloves is recommended when you remove the transfer roller.

- 2 Use a transfer-roller removal hook (callout 1) to lift the left end of the metal shaft out of place near the blue gear (callout 2). If a removal hook is not available use a flat-blade screwdriver. Slide the transfer roller to the left to remove it.

 **CAUTION** Be careful to release and lift the left side of the roller *first*, and then slide the roller out.

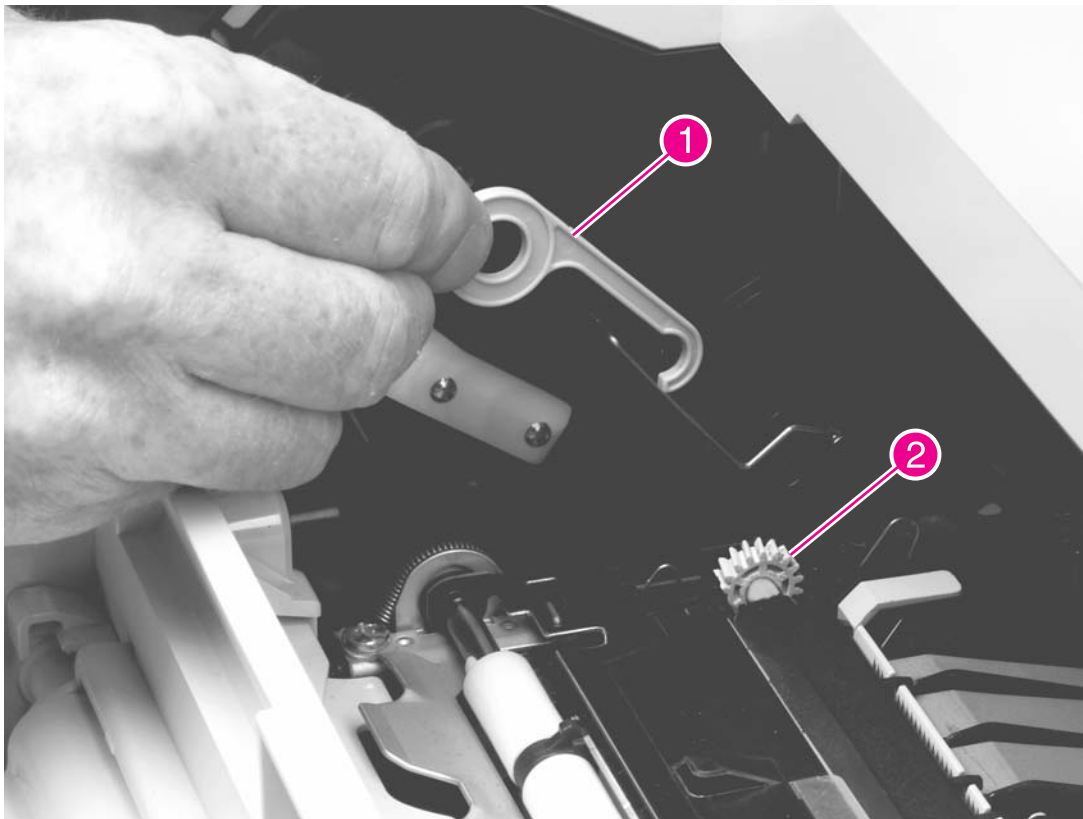



Figure 6-5 Transfer roller

 **Reinstallation tip** When you install the transfer roller, make sure that the black collar on the left side is oriented correctly, with the open end face-down (the solid end is face-up).

Tray 1 pickup roller



NOTE If the optional envelope feeder is installed, press the release button on its left side and remove the feeder. Then proceed to step 2.

- 1 Remove the front accessory cover (callout 1).



NOTE If the printer has an envelope feeder installed, this cover will *not* be in place.



Figure 6-7 Tray 1 pickup roller (1 of 2)

- 2 Release the pickup roller by sliding apart the latches that are located on each side at the top of the roller. Lift the roller (callout 3) out of the opening.

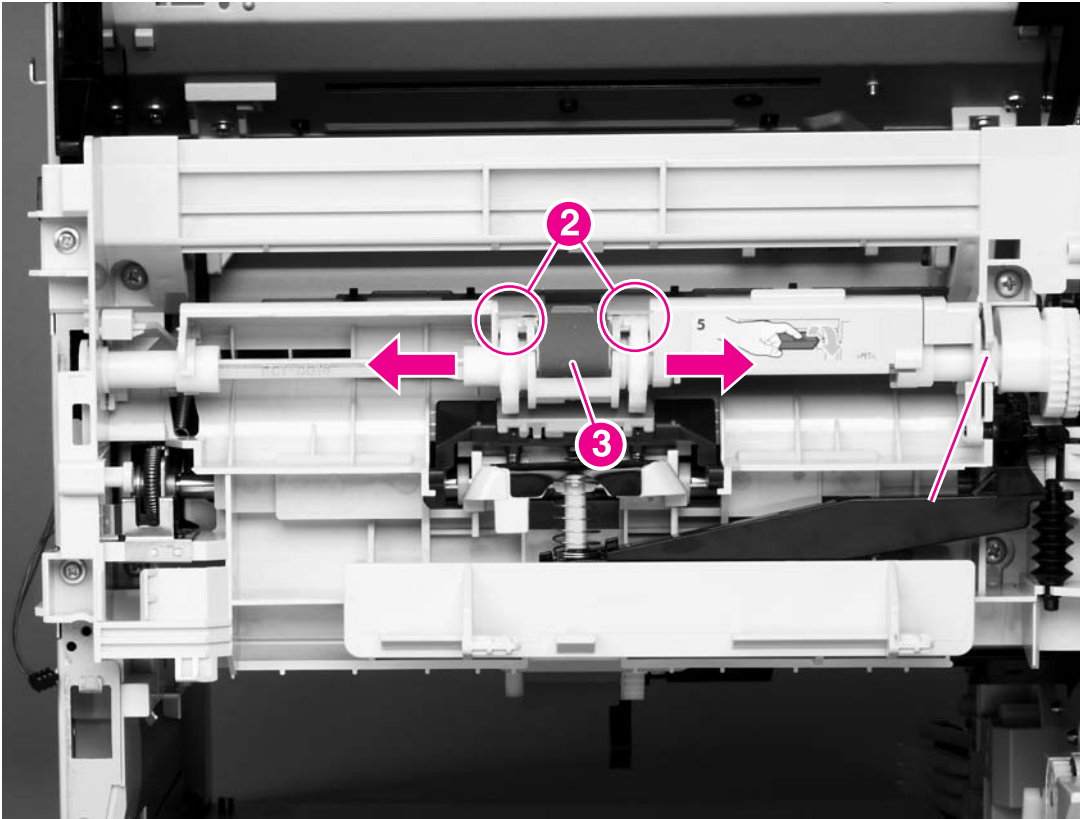

Figure 6-8 Tray 1 pickup roller (2 of 2)



Reinstallation tip When you install the pickup roller, place the two pivot pins in the lower mounting slots (callout 2) and rotate the roller into the printer until it snaps into place.

Tray 1 separation pad



NOTE If the optional envelope feeder is installed, press the release button on its left side and remove the feeder. Then proceed to step 2.

- 1 Remove the front accessory cover (not shown). See [Accessory covers and the tray 2 extension door](#).
- 2 Insert the tip of a small flat-blade screwdriver under the tray 1 separation pad.
- 3 Carefully twist the screwdriver to dislodge the separation pad. Remove the tray 1 separation pad.

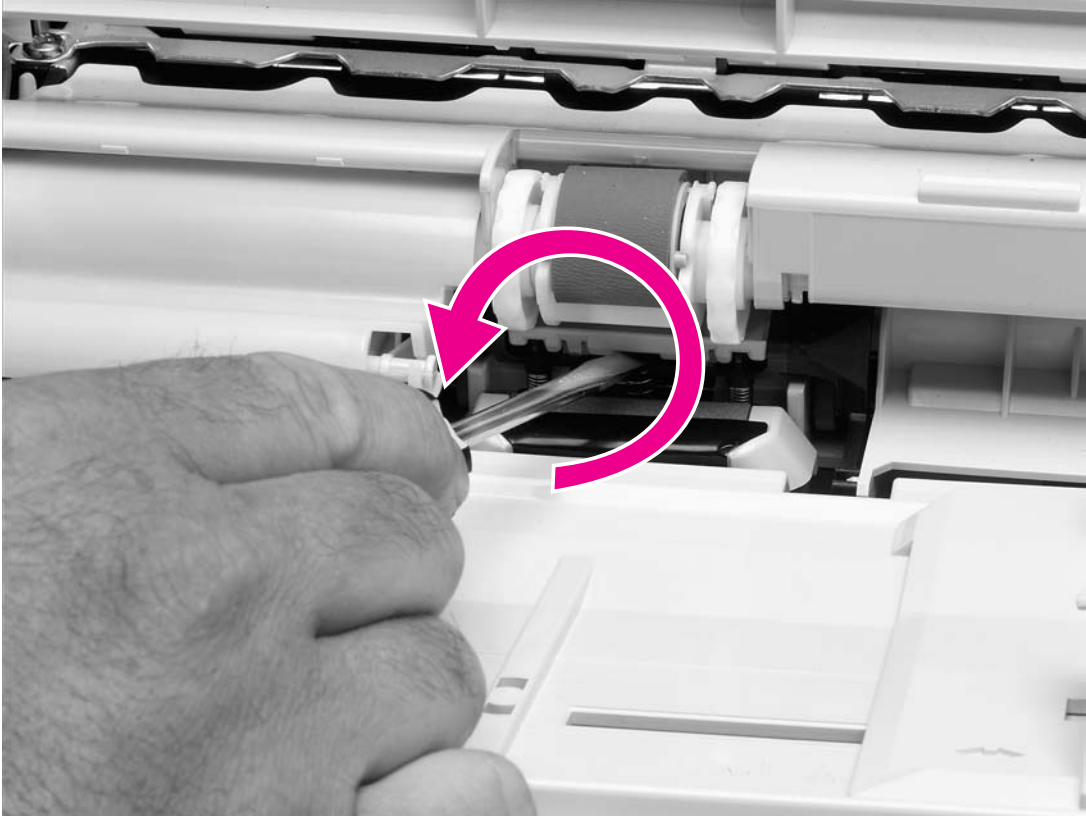

Figure 6-9 Tray 1 separation pad

Tray 2 feed rollers

- 1 Remove tray 2 and place it on a level work surface. Locate and open the cover (arrow) that is next to the roller in tray 2.

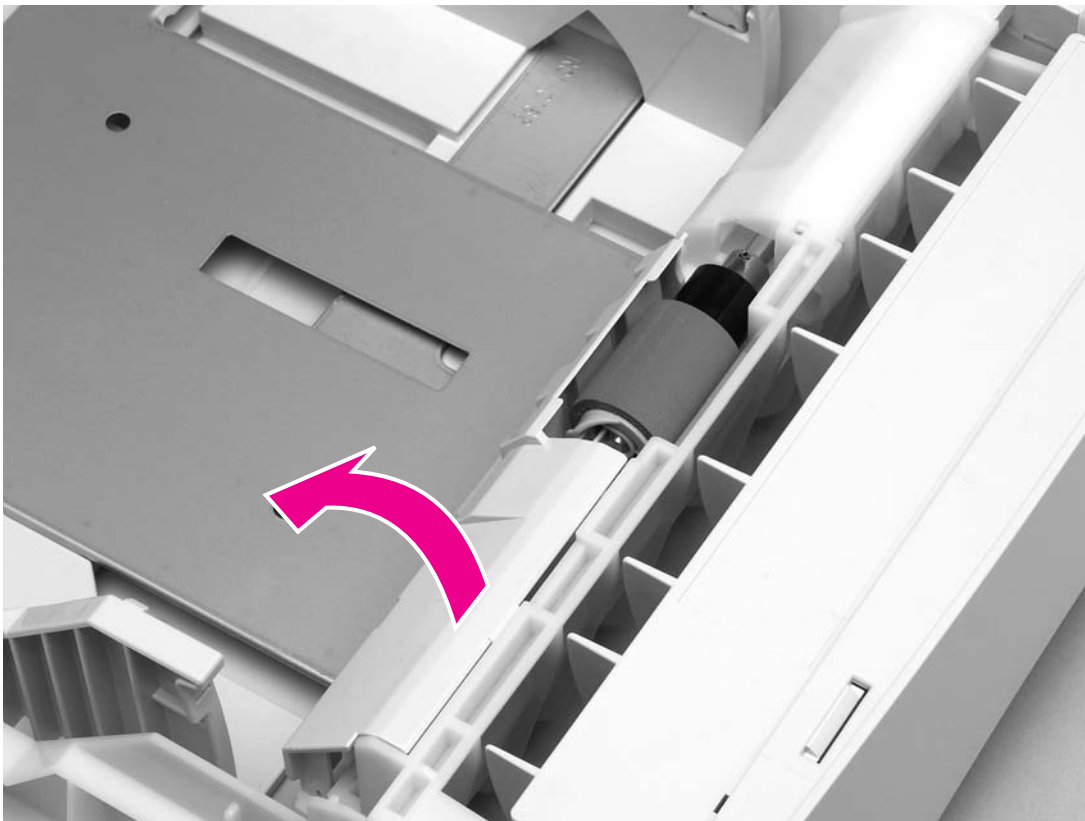

Figure 6-10 Tray 2 feed rollers (1 of 4)

- 2 Pinch the blue latch that is on the left side of the roller. Slide the roller off of the shaft (arrows).

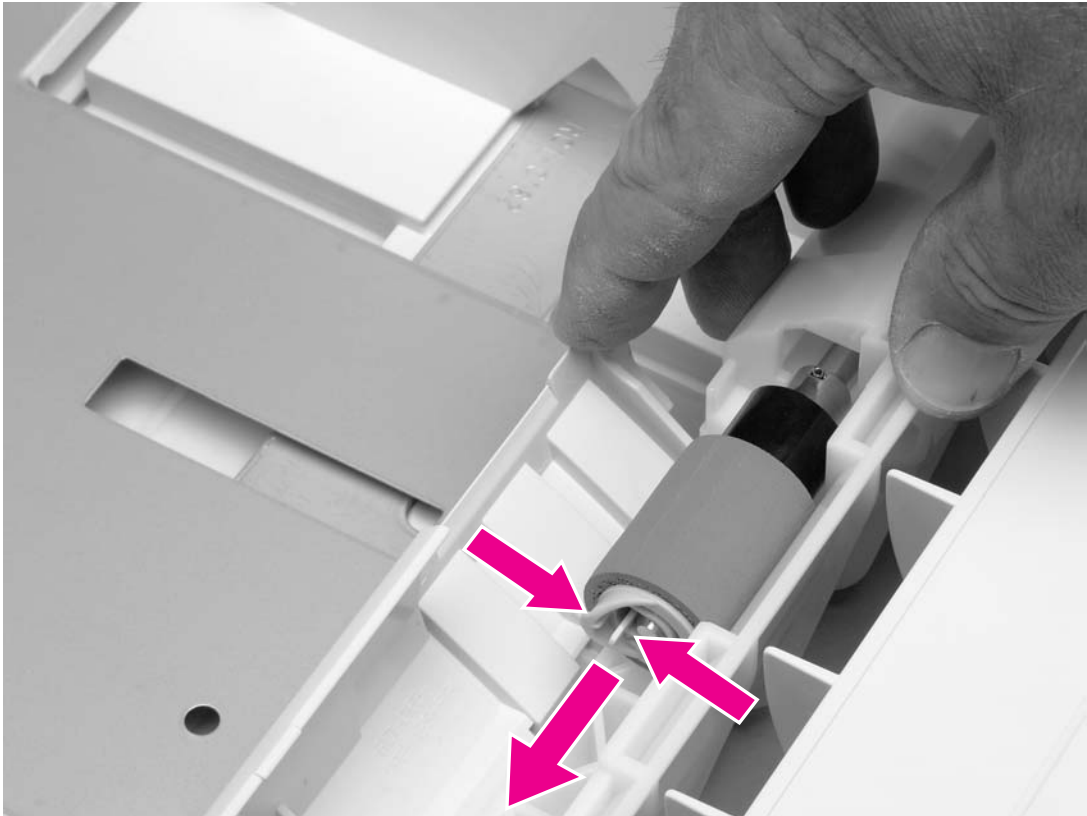



Figure 6-11 Tray 2 feed rollers (2 of 4)

 **CAUTION** When you install this roller, make sure that it locks into place. Verify that the roller is correctly oriented, and that the round, black spacer next to the roller is correctly positioned against the locking pin on the shaft.

 **WARNING!** Do not allow the front of the printer to extend beyond the edge of the work surface. The printer can become unbalanced and fall, which can cause damage to the printer or personal injury to the service technician.

- 3 Move the front of the printer to the edge of the work surface for better access to the remaining feed rollers. To find the rollers, look up into the inside of the opening that was created when you removed tray 2.



Figure 6-12 Tray 2 feed rollers (3 of 4)

- 4 Pinch the blue latch on the left side of the feed roller (two rollers are installed here). Slide the roller off of the shaft. You might need to rotate the roller in order to pinch the latch.

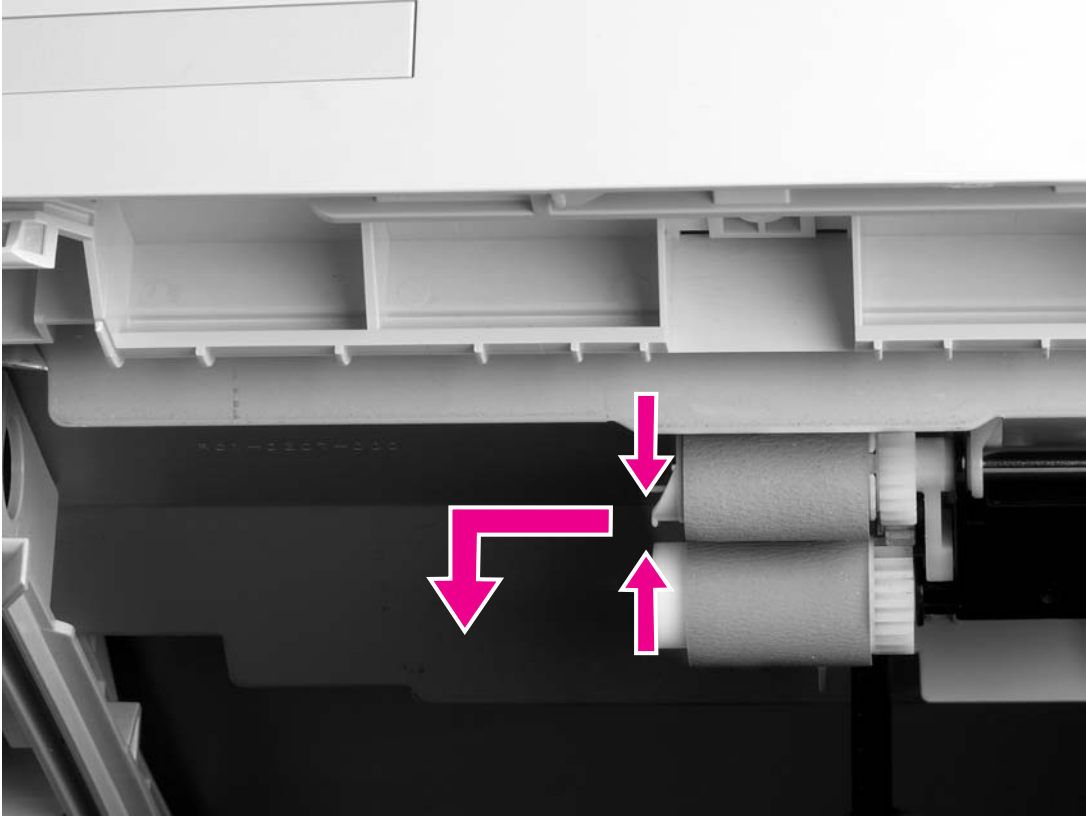

Figure 6-13 Tray 2 feed rollers (4 of 4)

- 5 Repeat the previous step for the remaining pickup roller.



Reinstallation tip When you install each of the rollers that you removed in steps 4 and 5, make sure that it locks into place on the tabs that are on the drive gear.