

Fusing Assembly

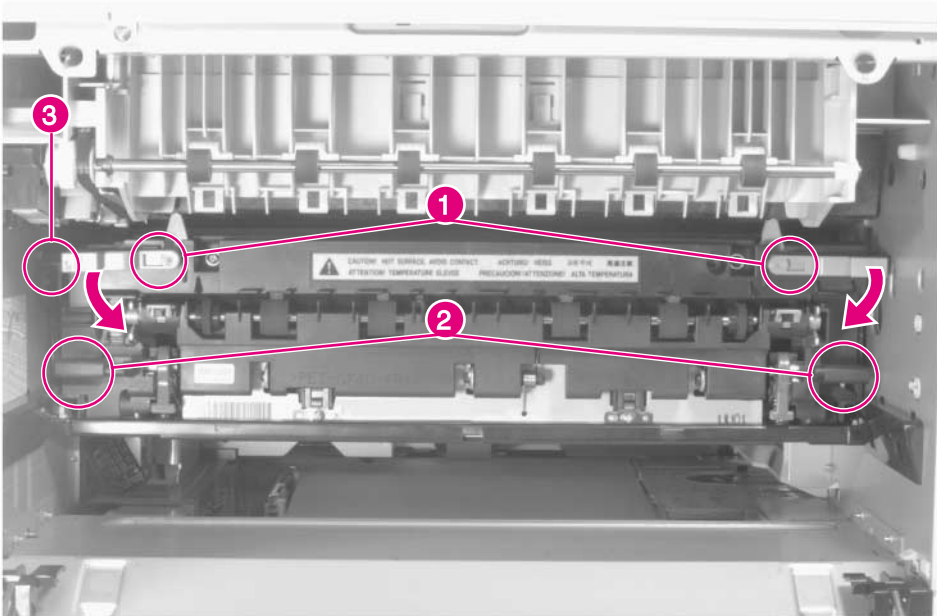

Figure 6-36 Fusing Assembly

- 1 Open the Diverter Assembly access door, and remove the Duplexer if installed.



Use the upper levers to release the Fusing Assembly, NOT the lower levers. The lower levers set the pressure rollers inside the Fusing Assembly for envelope printing (down for single sheets, up for envelopes).

- 2 To release the Fusing Assembly rotate the upper levers down (figure 6-36, callout 1).
- 3 To remove the Fusing Assembly lift up on the finger handles (figure 6-36, callout 2) while pulling outward.

To Reinstall:

- 1** Make sure that the Fuser Output sensor flag (figure 6-36, callout 3) on the upper left corner of the Fusing Assembly rotates freely.
- 2** Make sure that the lower levers are set down for single sheets. If having trouble printing envelopes, move the levers up. Move the levers back down when done.

Transfer Roller Assembly

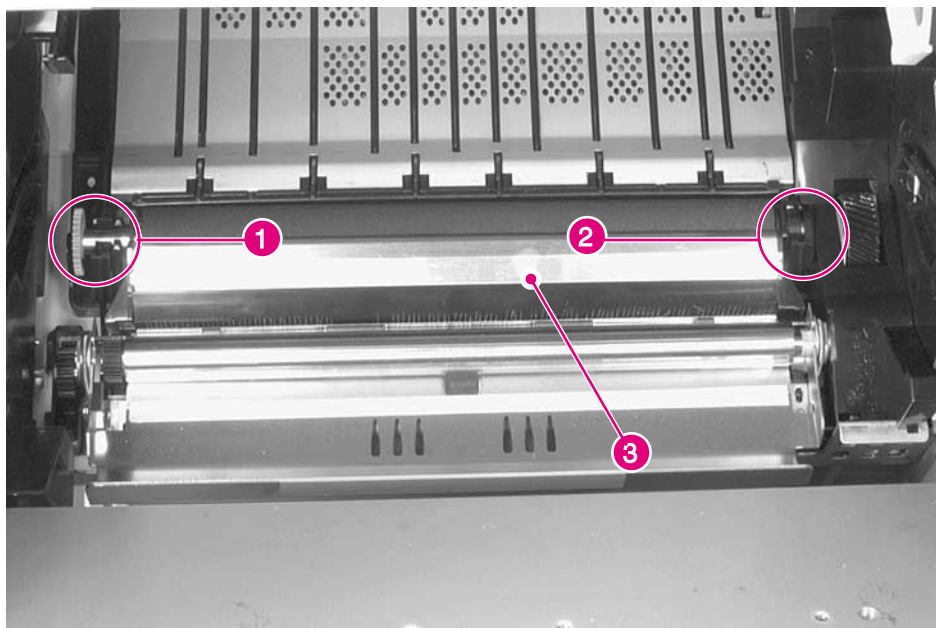

Figure 6-62 Transfer Roller Assembly

CAUTION

Handle the Transfer Roller from the ends only. Do not touch the surface of the Transfer Roller. Skin oils will affect its electrical characteristics, resulting in poor image transfer.

- 1 Open the top cover door, and remove the toner cartridge.
- 2 Grasp the gear (figure 6-62, callout 1) on the left end, and carefully lift upward just enough to clear the retainer clip.
- 3 Slide the Transfer Roller Assembly to the left to release the shaft on the right end (figure 6-62, callout 2).

To Reinstall:

- 1** Place the right end of the shaft into its retaining cavity.
- 2** Hold the Transfer Roller wiper up (figure 6-62, callout 3) and slide the assembly to the right until the gear on the left end is in position.
- 3** Carefully press the left end of the shaft into the retainer clip.
- 4** Press the Transfer Roller wiper down (figure 6-62, callout 3) until the retaining clips snap into place.

Tray 1 Feed Roller and Separation Pad

Feed Roller

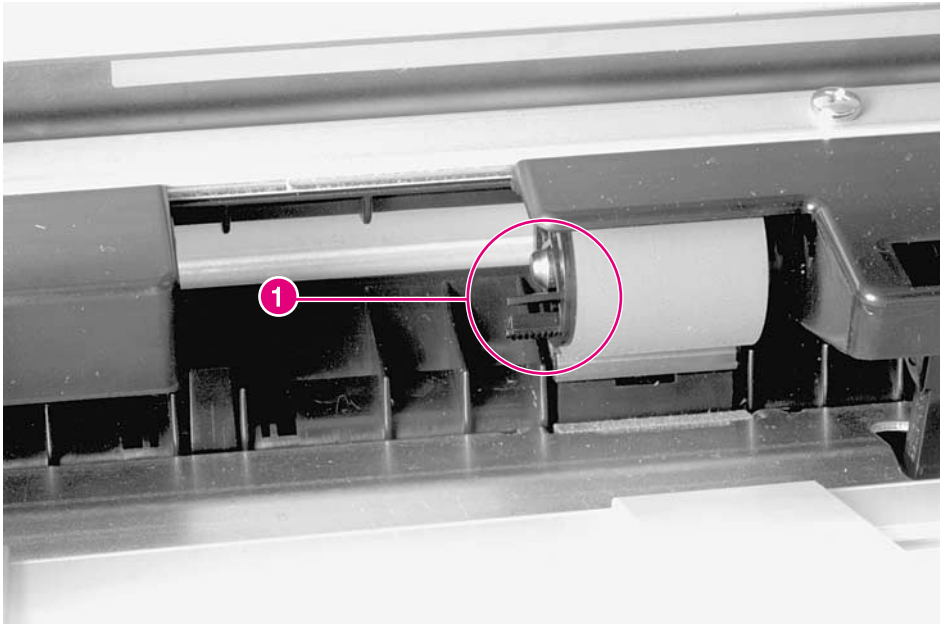

Figure 6-56 Tray 1 Feed Roller

- 1 Open the Tray 1 door, and remove the plastic shield.
- 2 Pinch the retainer tabs together (figure 6-56, callout 1), and slide the roller to the left off of the shaft.

Tray 1 Separation Pad

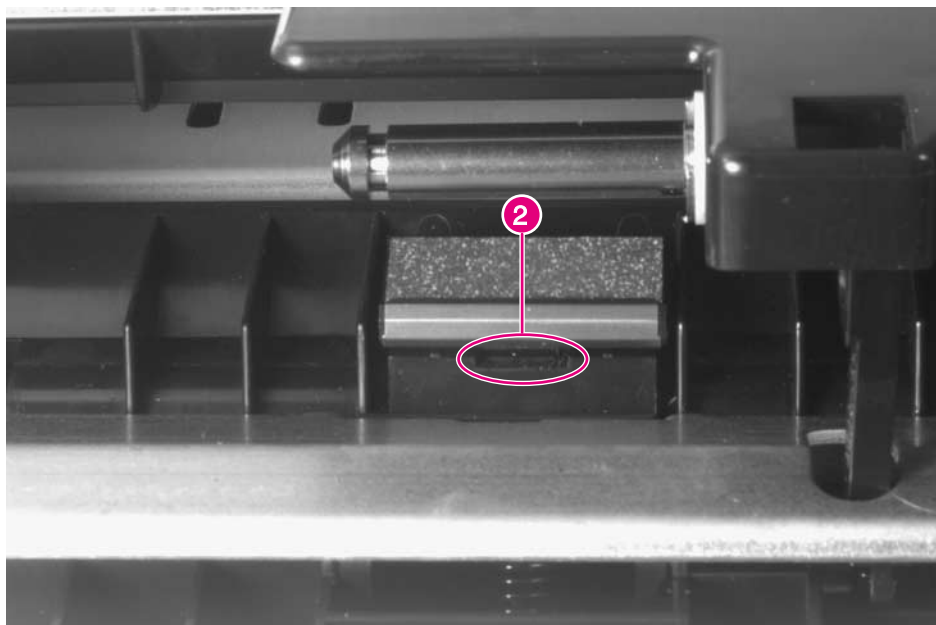

Figure 6-57 Tray 1 Separation Pad

- 1 Open the Tray 1 door, and remove the Feed Roller.
- 2 Insert a flat-bladed screwdriver into the slot (figure 6-57, callout 2), and carefully pry the separation pad upwards out of its retaining notches.

To Reinstall:

Make sure the metal edge of the Separation Pad faces forward.

Tray 2 and 3 Pickup, Feed, and Separation Rollers

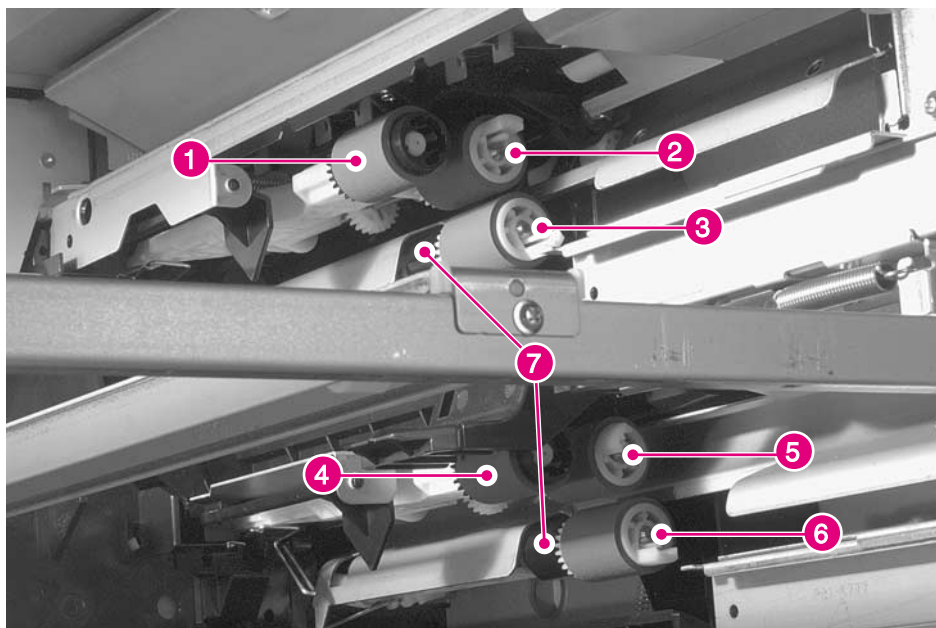

Figure 6-58 Tray 2 and 3, Pickup, Feed, and Separation Rollers

There are three rollers for each tray: the Pickup Roller, the Feed Roller, and the Separation Roller. The Feed and Separation Rollers are interchangeable with each other and between trays. The Pickup Rollers are interchangeable between trays.

- Tray 2 Pickup Roller: figure 6-58, callout 1
- Tray 2 Feed Roller: figure 6-58, callout 2
- Tray 2 Separation Roller: figure 6-58, callout 3
- Tray 3 Pickup Roller: figure 6-58, callout 4
- Tray 3 Feed Roller: figure 6-58, callout 5
- Tray 3 Separation Roller: figure 6-58, callout 6

Note

The Feed and Separation rollers have protruding tabs, and the pickup rollers have recessed retaining tabs. Be careful not to lose the plastic torque limiters located behind the Separation Rollers (figure 6-58, callout 7).

- 1 Remove trays. From inside the tray cavity, remove the rollers by pinching the retainer tabs together and sliding the roller off the shaft.