NOTE

When performing any servicing inside the printer, all four print cartridges should be removed.

2. Do not touch the surface of the print cartridge drum (2). The cartridges have flaps that close when the front door is opened to protect the print drum. However, if the flaps do not close, flip them down to cover the exposed area of the print drum.

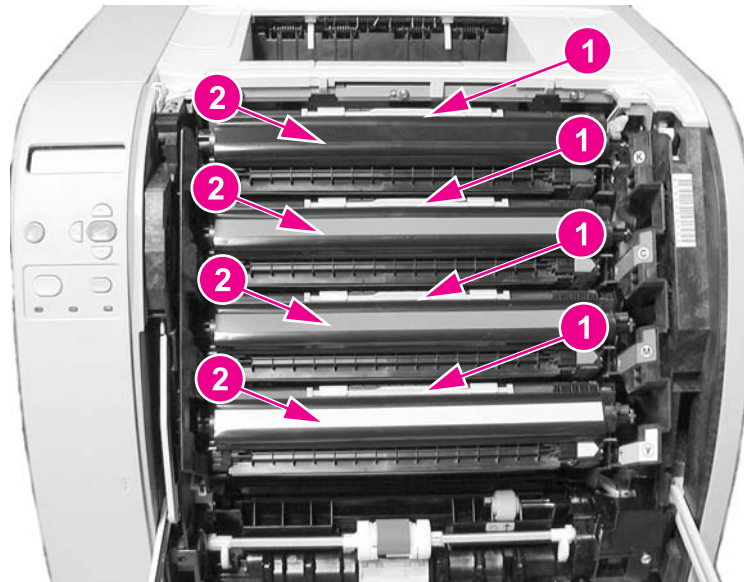

Figure 6-19. Print cartridge removal

Grasp the blue handle (1) of a cartridge and pull it slightly upward and out to remove it.

Fuser removal

WARNING!

Be sure to turn the power off and unplug the power cord before removing the fuser.

When removing the fuser, wait ten minutes to allow it to cool before removing it.

NOTE

If the fuser failed or has been replaced for some reason other than reaching its end-of-life (end-of-life is indicated by a control panel message stating that the fuser requires replacement) then, in addition to replacing it, a configuration procedure must be performed. For information on this configuration, refer to Chapter 8, [Replacement parts configuration](#) Replacement parts configuration.

1. Remove the lower rear door. See [Lower rear door \(rear output bin\) removal](#).

2. Hold the release tabs on each side of the fuser by placing your thumbs on the top tabs (1) and your forefingers on the lower tabs (2). Press up on the bottom tabs (2) to release the assembly and pull it toward you to remove it.

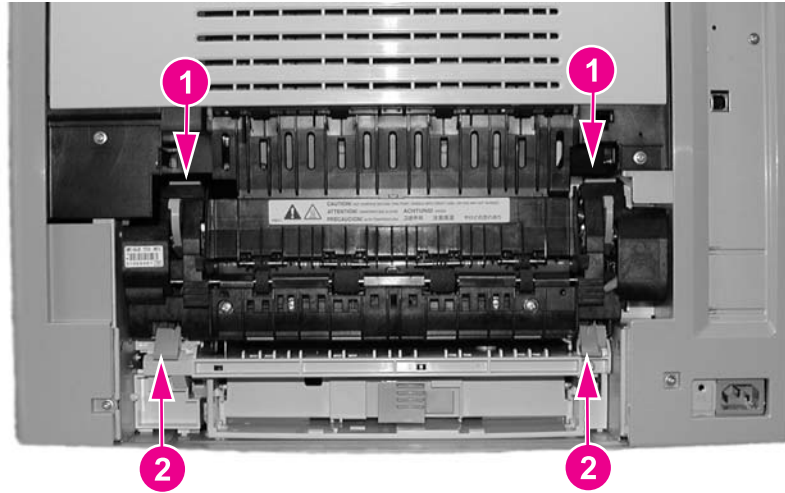

Figure 6-20. Fuser removal

Face-down delivery assembly removal

1. Remove the following covers:
 - a. Upper rear door, see [Upper rear door removal](#).
 - b. Rear cover, see [Rear cover removal](#).
 - c. Lower rear door, see [Lower rear door \(rear output bin\) removal](#).
 - d. Right cover, see [Right cover removal](#).
 - e. Left cover, see [Left cover removal](#).
 - f. Left front cover, see [Left front cover removal](#).
 - g. Top cover, see [Top cover removal](#).
2. Remove six screws (1).

Secondary transfer charging roller removal

1. Remove the transfer unit and the print cartridges. See [Transfer unit removal](#) and [Print cartridge removal](#).

CAUTION

When handling the secondary transfer charging roller, hold the shaft and bushing; do not hold the sponge part of the roller.

2. Lift the blue handle (1) straight up, once the right side is out, continue lifting to release the left side and remove the roller (2).

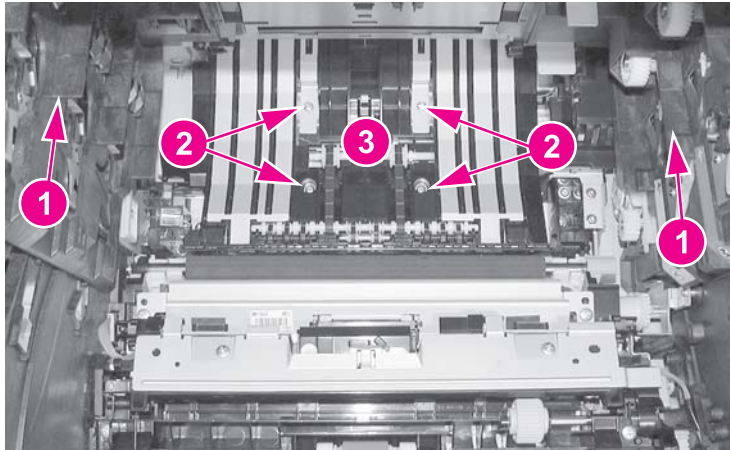

Figure 6-48.

Secondary transfer charging roller removal

Reinstallation tip

When handling the secondary transfer charging roller, hold the shaft ends and bushings; do not hold the sponge part of the roller.

Fuser sleeve unit removal

Replacement of the fuser sleeve unit requires replacement of the entire fuser. See [Fuser removal](#).

Pressure roller removal

Replacement of the pressure roller requires replacement of the entire fuser. See [Fuser removal](#).

Main thermistor/sub-thermistor removal

Replacement of the main thermistor and the sub thermistor requires replacement of the entire fuser. See [Fuser removal](#).

Thermoswitch removal

Replacement of the thermoswitch requires replacement of the entire fuser. See [Fuser removal](#).

Transfer unit removal

CAUTION

Do not touch the surface (5), shown in the figure below, of the image transfer belt (ITB) since it can cause an image defect.

NOTE

If the transfer unit failed or has been replaced for some reason other than reaching its end-of-life (end-of-life is indicated by a control panel message stating that the transfer unit requires replacement) then, in addition to replacing the unit, a configuration procedure must be performed. For information on this configuration, refer to Chapter 8, [Replacement parts configuration](#).

1. Open the front door.

2. Hold the blue handles (1) on both sides of the transfer unit. With your right thumb, press and hold the lever (2) on the right side handle then lift the handle up (3), followed by the left side (4) to remove the unit.

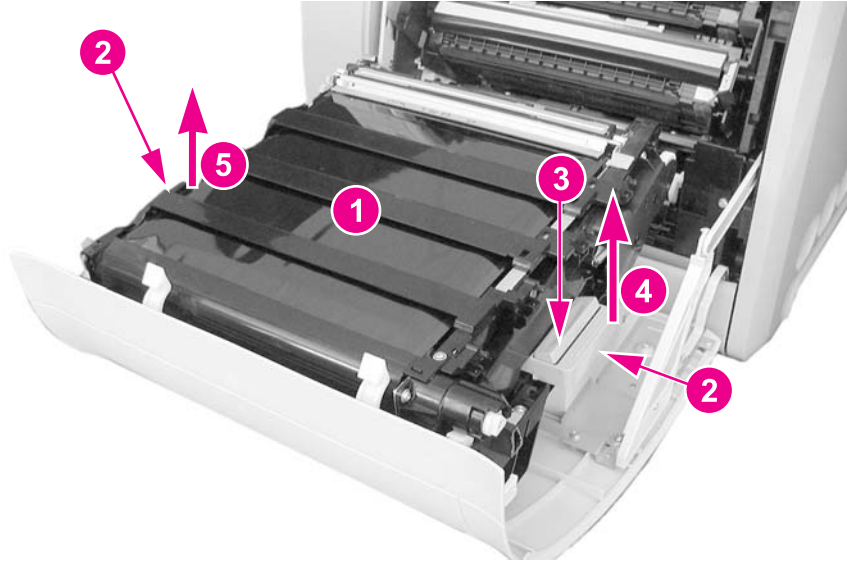

Figure 6-17. Transfer unit removal

Reinstallation tip

When reinstalling the transfer unit, align the two pins (1) on the left side of the door with the two holes (2) in the left side of the transfer unit.

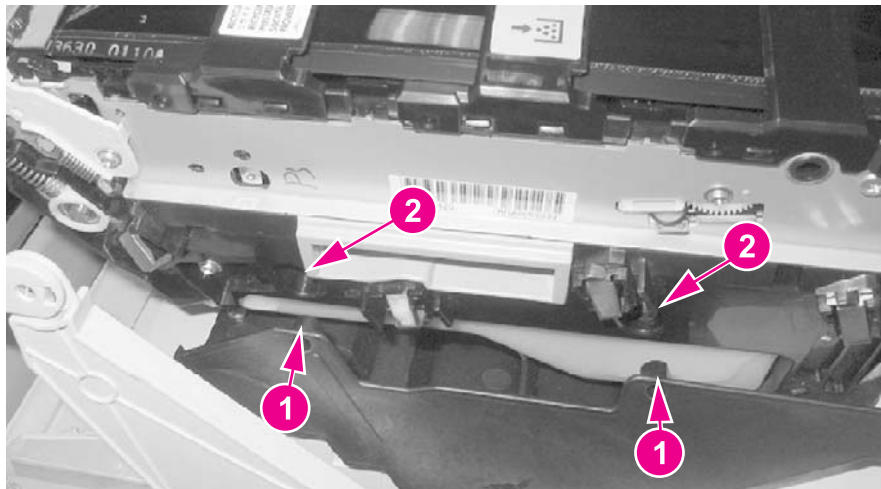

Figure 6-18. Transfer unit installation

Print cartridge removal

1. Open the front door.

Tray 1 pick-up roller removal

1. Remove the transfer unit. See [Transfer unit removal](#).
2. Unhook one claw (1) and slide the idler roller (2) in the direction of the arrow.
3. Rotate the Tray 1 pick-up roller (3) upwards to release it from the shaft and lift the roller out.

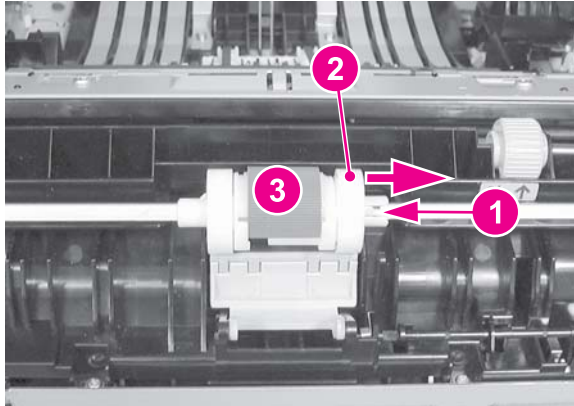

Figure 6-44.

Tray 1 pick-up roller removal

NOTE

Replace the separation pad whenever you replace the pick-up roller.

Tray 1 separation pad removal

1. Remove the Tray 1 pick-up roller. See [Tray 1 pick-up roller removal](#), above.
2. Slide the left idler roller (1) in the direction of the arrow (2).
3. Place a flat-blade screwdriver under each slot (3) and twist the screwdriver to pry the pad loose to remove it.

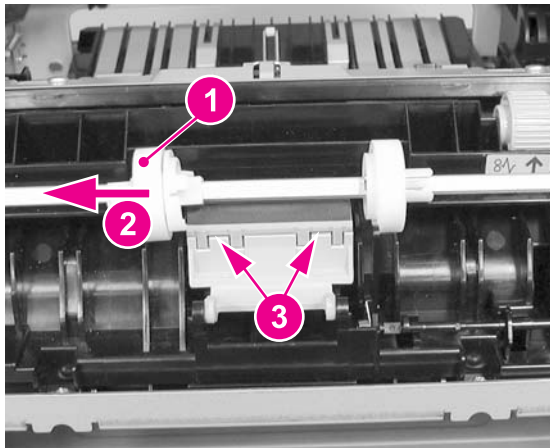

Figure 6-45.

Tray 1 separation pad removal

NOTE

Replace the pick-up roller whenever you replace the separation pad.

Tray 1 pick-up roller removal

1. Remove the transfer unit. See [Transfer unit removal](#).
2. Unhook one claw (1) and slide the idler roller (2) in the direction of the arrow.
3. Rotate the Tray 1 pick-up roller (3) upwards to release it from the shaft and lift the roller out.

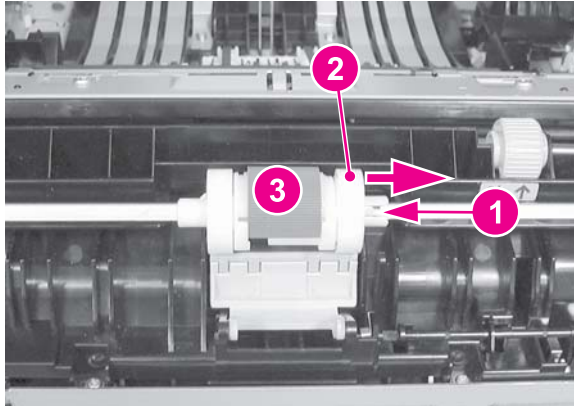

Figure 6-44.

Tray 1 pick-up roller removal

NOTE

Replace the separation pad whenever you replace the pick-up roller.

Tray 1 separation pad removal

1. Remove the Tray 1 pick-up roller. See [Tray 1 pick-up roller removal](#), above.
2. Slide the left idler roller (1) in the direction of the arrow (2).
3. Place a flat-blade screwdriver under each slot (3) and twist the screwdriver to pry the pad loose to remove it.

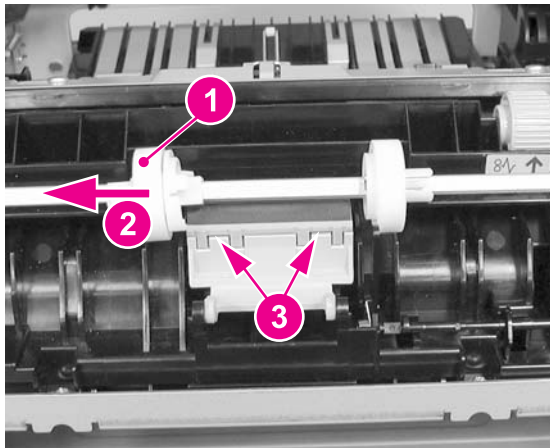

Figure 6-45.

Tray 1 separation pad removal

NOTE

Replace the pick-up roller whenever you replace the separation pad.

Tray 2 pick-up roller removal

1. Remove Tray 2.
2. Push the roller (1) in the direction of the arrow, then remove it by pulling the right side out (2) first.

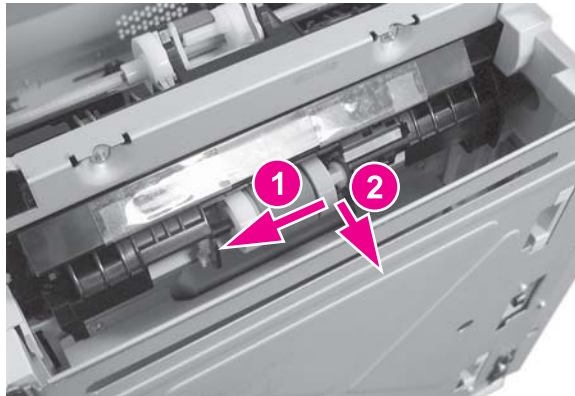

Figure 6-46.

Tray 2 pick-up roller removal

Tray 2 separation pad removal

1. Remove Tray 2.
2. Remove any paper from the tray.
3. Push the lifting plate (1) down.
4. Unhook two claws (2) by pressing in on them, then lift up on the separation pad (3) to remove it.

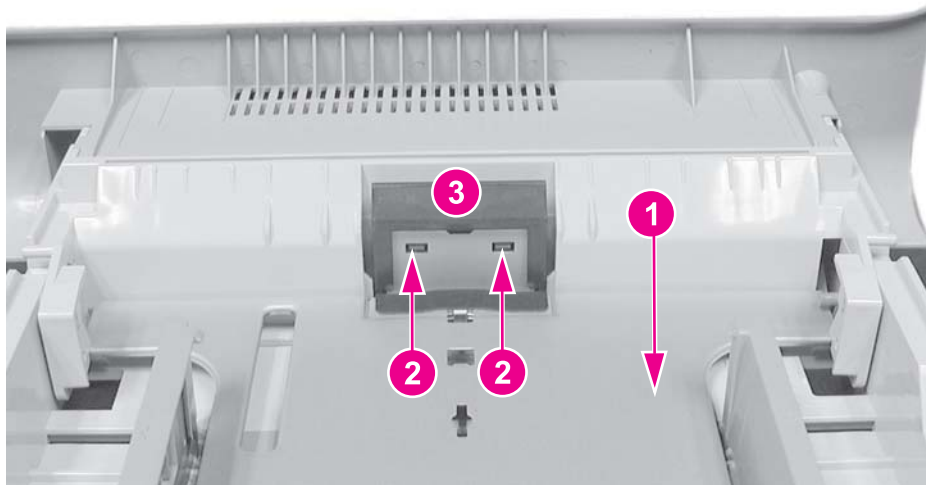

Figure 6-47.

Tray 2 separation pad removal

Reinstallation tip

The separation pad contains a spring attached to the back side of the pad. This spring must be removed and installed on the replacement pad.

Tray 2 pick-up roller removal

1. Remove Tray 2.
2. Push the roller (1) in the direction of the arrow, then remove it by pulling the right side out (2) first.

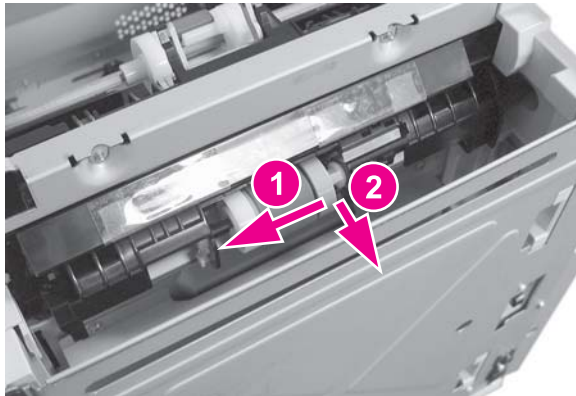

Figure 6-46.

Tray 2 pick-up roller removal

Tray 2 separation pad removal

1. Remove Tray 2.
2. Remove any paper from the tray.
3. Push the lifting plate (1) down.
4. Unhook two claws (2) by pressing in on them, then lift up on the separation pad (3) to remove it.

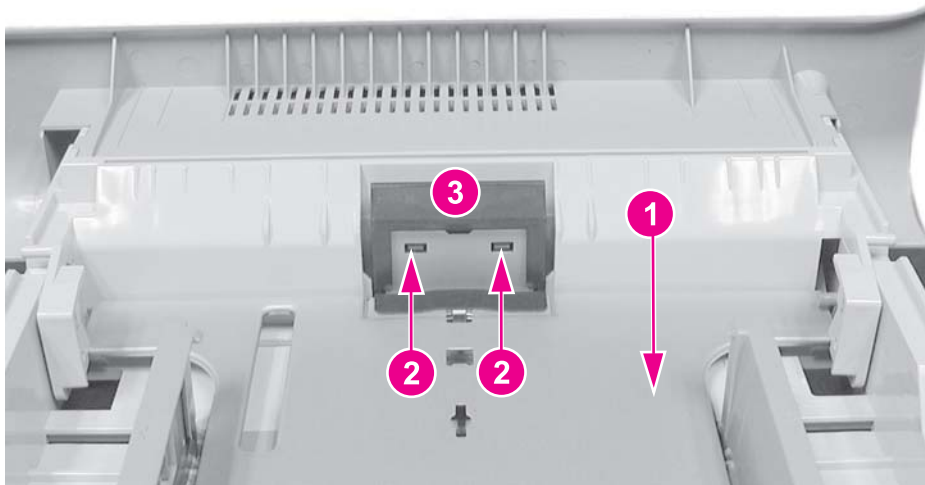

Figure 6-47.

Tray 2 separation pad removal

Reinstallation tip

The separation pad contains a spring attached to the back side of the pad. This spring must be removed and installed on the replacement pad.