

Internal assemblies

Figure 2-3 Internal assemblies

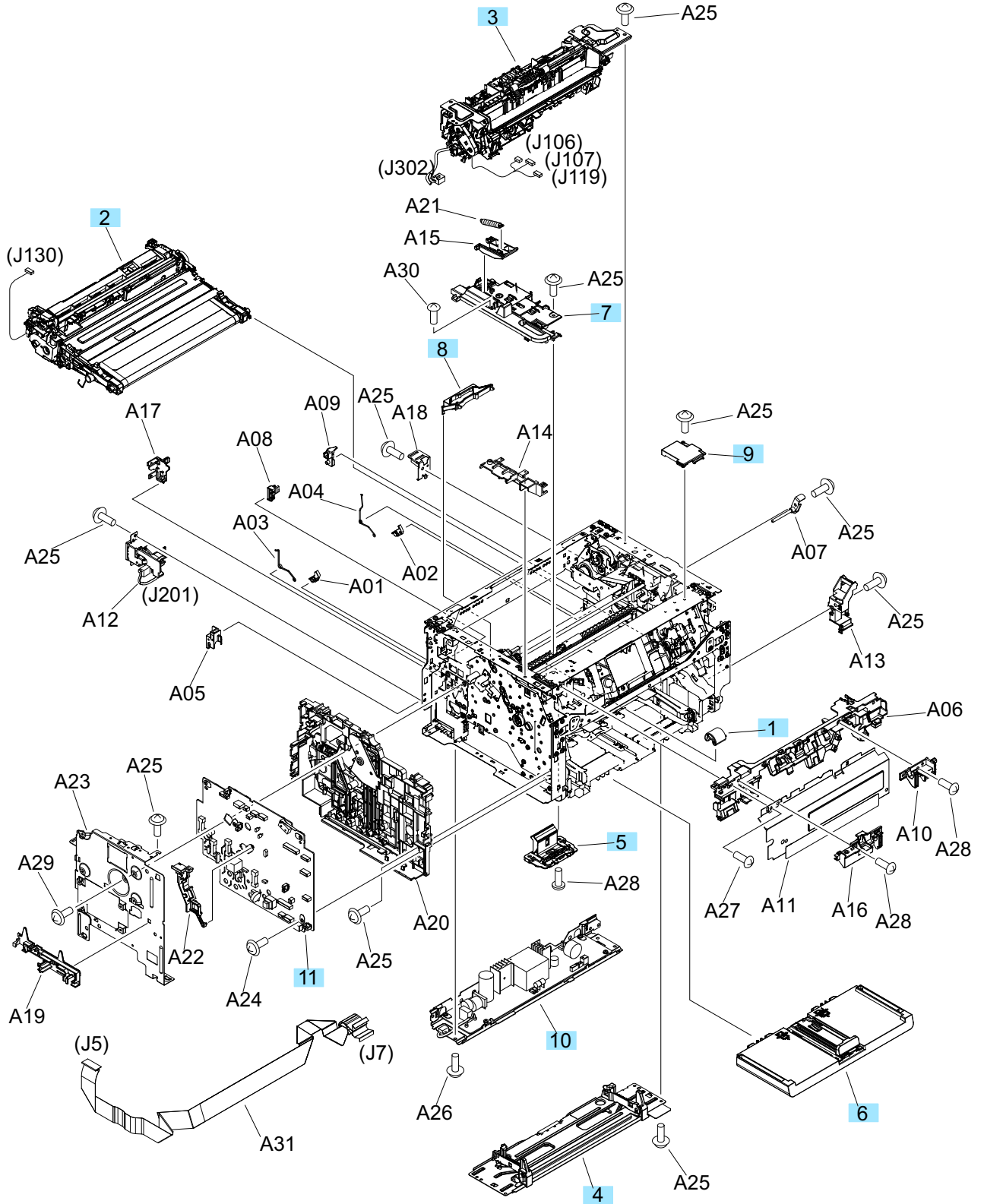

Table 2-9 Internal assemblies

Ref	Description	Part number	Qty
1	Roller, paper pick-up	RL1-2671-000CN	1
2	Intermediate transfer belt assembly (ITB)	RM2-0175-000CN	1
3	Fuser delivery assembly (110-127 V)	RM2-0157-000CN	1
3	Fuser delivery assembly (220–240 V)	RM2-0167-000CN	1
4	Base plate assembly	RM2-0160-000CN	1
5	Separation pad assembly	RM2-0170-000CN	1
6	Main tray assembly	RM2-0144-000CN	1
7	Inner cover assembly	RM2-0139-000CN	1
8	Support, frame	RC3-0230-000CN	1
9	Cover, grounding cable	RC3-5365-000CN	1
10	Low voltage power supply assembly (110-127V)	RM2-7292-000CN	1
10	Low voltage power supply assembly (220-240V)	RM2-7293-000CN	1
11	Engine controller PCA	RM2-7300-000CN	1
	Fax module–Asia/US (M177 model) (not shown)	CF206-60001	1
	Fax module–EU (M177 model) (not shown)	CF207-60001	1
	Fax module–Brazil (M177 model) (not shown)	CF208-60001	1
	PCA, formatter (M176 model) (not shown)	CF547-60001	1
	PCA, formatter (M177 model) (not shown)	CZ165-60001	1
	WiFi board (M177 model) (not shown)	1150-7957	1