



Service Manual

Lexmark™ W840 Finisher

4024-XXX

- ***Table of contents***
- ***Start diagnostics***
- ***Safety and notices***
- ***Trademarks***
- ***Index***

LEXMARK™

Lexmark and Lexmark with diamond design are trademarks of Lexmark International, Inc., registered in the United States and/or other countries.

Edition: September 8, 2005

The following paragraph does not apply to any country where such provisions are inconsistent with local law:

LEXMARK INTERNATIONAL, INC. PROVIDES THIS PUBLICATION "AS IS" WITHOUT WARRANTY OF ANY KIND, EITHER EXPRESS OR IMPLIED, INCLUDING, BUT NOT LIMITED TO, THE IMPLIED WARRANTIES OF MERCHANTABILITY OR FITNESS FOR A PARTICULAR PURPOSE. Some states do not allow disclaimer of express or implied warranties in certain transactions; therefore, this statement may not apply to you.

This publication could include technical inaccuracies or typographical errors. Changes are periodically made to the information herein; these changes will be incorporated in later editions. Improvements or changes in the products or the programs described may be made at any time.

Comments may be addressed to Lexmark International, Inc., Department D22A/032-2, 740 West New Circle Road, Lexington, Kentucky 40550, U.S.A or e-mail at ServiceInfoAndTraining@Lexmark.com. Lexmark may use or distribute any of the information you supply in any way it believes appropriate without incurring any obligation to you. You can purchase additional copies of publications related to this product by calling 1-800-553-9727. In other countries, contact your point of purchase.

References in this publication to products, programs, or services do not imply that the manufacturer intends to make these available in all countries in which it operates. Any reference to a product, program, or service is not intended to state or imply that only that product, program, or service may be used. Any functionally equivalent product, program, or service that does not infringe any existing intellectual property right may be used instead. Evaluation and verification of operation in conjunction with other products, programs, or services, except those expressly designated by the manufacturer, are the user's responsibility.

Lexmark and Lexmark with diamond design are trademarks of Lexmark International, Inc., registered in the United States and/or other countries.

Other trademarks are the property of their respective owners.

**© 2005 Lexmark International, Inc.
All rights reserved.**

UNITED STATES GOVERNMENT RIGHTS

This software and any accompanying documentation provided under this agreement are commercial computer software and documentation developed exclusively at private expense.

Table of contents

| | |
|---|------------|
| Notices and safety information | ix |
| Laser notice | ix |
| Safety information | xiii |
| Preface | xvi |
| Definitions | xvi |
| General information | 1-1 |
| Finisher weight | 1-1 |
| Components | 1-1 |
| Media size and weight | 1-2 |
| Media size/orientation and applicable functions | 1-2 |
| Media weight | 1-4 |
| Tools required for service | 1-4 |
| Features | 1-4 |
| Acronyms | 1-5 |
| Diagnostic information | 2-1 |
| Start | 2-1 |
| Using service checks | 2-1 |
| Confirm the installation status | 2-2 |
| Error code messages | 2-3 |
| Service checks | 2-11 |
| 280.00 Sensor (bridge unit media entrance) on Jam | 2-11 |
| 280.01 Sensor (bridge unit media entrance) static jam A | 2-12 |
| 280.02 Sensor (bridge unit media entrance) static jam B | 2-13 |
| 281.00 Sensor (bridge unit media exit) On Jam A | 2-14 |
| 281.01 Sensor (bridge unit media exit) On Jam B | 2-15 |
| 281.02 Sensor (bridge unit media exit) On Jam C | 2-17 |
| 281.03 Sensor (bridge unit media exit) static jam A | 2-18 |
| 282.00 Sensor (finisher media entrance) on jam | 2-19 |
| 282.01 Sensor (finisher media entrance) static jam A | 2-21 |
| 283.00 Sensor (buffer path) on jam A | 2-22 |
| 283.01 Sensor (buffer path) on jam B | 2-24 |
| 283.02 Sensor (buffer path) static jam A | 2-26 |
| 283.03 Sensor (buffer path) static jam B | 2-27 |
| 283.04 Sensor (buffer path) static jam C | 2-28 |
| 284.00 Sensor (lower media exit) off jam A | 2-28 |
| 284.01 Sensor (lower media exit) on jam A | 2-30 |
| 284.02 Sensor (lower media exit) on jam B | 2-32 |
| 284.03 Sensor (lower media exit) on jam C | 2-34 |
| 284.04 Sensor (lower media exit) off jam B | 2-36 |
| 284.05 Sensor (lower media exit) static jam | 2-37 |
| 285.00 Finisher eject set jam | 2-37 |
| 286.00 Sensor (compiler media in) static jam | 2-38 |
| 287.00 Sensor (upper media exit) on jam A | 2-40 |
| 287.01 Sensor (upper media exit) off jam A | 2-41 |
| 287.02 Sensor (upper media exit) on jam B | 2-42 |
| 287.03 Sensor (upper media exit) on jam C | 2-44 |
| 287.04 Sensor (upper media exit) off jam B | 2-45 |
| 287.05 Sensor (upper media exit) static jam A | 2-46 |
| 287.06 Sensor (upper media exit) static jam B | 2-47 |
| 287.07 Sensor (upper media exit) static jam C | 2-48 |
| 288.00 Sensor (diverter gate) on jam | 2-49 |
| 288.01 Sensor (diverter gate) static jam (to top bin) A | 2-51 |

288.02 Sensor (diverter gate) static jam (to top bin) B 2-52
 288.03 Sensor (diverter gate) static jam (to top bin) C 2-53
 288.04 Sensor (diverter gate) static jam (to stacker bin) A 2-54
 288.05 Sensor (diverter gate) static jam (to stacker bin) B 2-55
 288.06 Sensor (diverter gate) static jam (to stacker bin) C 2-56
 980.02 Finisher communication failure 2-56
 981.00 Stacker bin failure 2-57
 981.01 Stacker bin upper limit failure 2-59
 981.02 Stacker bin lower limit failure 2-60
 982.00 Sensor (front tamper HP) on failure 2-62
 982.01 Sensor (front tamper HP) off failure 2-63
 983.00 Sensor (rear tamper HP) on failure 2-64
 983.01 Sensor (rear tamper HP) off failure 2-65
 984.00 Sensor (punch unit HP) on failure 2-66
 984.01 Sensor (punch unit HP) off failure 2-67
 985.00 Sensor (punch carriage shift HP) on failure 2-68
 985.01 Sensor (punch carriage shift HP) off failure 2-69
 986.00 Sensor (media eject clamp HP) on failure 2-70
 986.01 Sensor (media eject clamp HP) off failure 2-71
 987.00 Sensor (media eject shaft HP) on failure 2-72
 987.01 Sensor (media eject shaft HP) off failure 2-74
 988.00 Sensor (punch unit side reg) on failure 2-75
 988.01 Sensor (punch unit side reg) off failure 2-76
 989.00 Stapler unit failure 2-78
 990.00 Sensor (stapler carriage HP) on failure 2-78
 990.01 Sensor (stapler carriage HP) off failure 2-79
 995.00 Finisher NVRAM R/W failure 2-80
 996.00 Finisher type failure 2-80
 999.00 Finisher engine/RIP functional failure 2-81
 Bridge unit top cover open 2-81
 Finisher front door open 2-82
 Finisher eject cover open 2-83
 Finisher upper media bin full 2-84
 No punch waste box. 2-85
 Punch waste box full 2-86
 Stacker media bin full (mix size) 2-86
 Stacker media bin full (no mix) 2-88
 Stacker lower safety failure 2-90
 Stacker set over count failure 2-92
 Staple cartridge empty 2-92

Diagnostic aids 3-1

Accessing Diagnostics mode 3-1
 Available finisher tests 3-1
 FINISHER TESTS 3-2
 Staple Test 3-2
 Hole Punch Test 3-2
 Feed Tests 3-2
 Sensor Test (finisher) 3-2
 EXIT DIAGNOSTICS 3-3

| | |
|--|-------------|
| Theory | 3-4 |
| Media transport | 3-4 |
| Bridge unit assembly paper path | 3-4 |
| Finisher media path | 3-4 |
| Finisher roll assemblies | 3-5 |
| Finisher media path sensors | 3-5 |
| Finisher motors | 3-6 |
| Bridge unit assembly | 3-6 |
| From bridge unit assembly to punch | 3-7 |
| From punch to compiler unit assembly | 3-8 |
| From compiler unit assembly to stacker media bin | 3-10 |
| From punch to upper media bin | 3-10 |
| Functions of sensors along the media path | 3-10 |
| Bridge unit assembly | 3-10 |
| Finisher | 3-11 |
| Punch unit | 3-12 |
| Adjusting punching positions | 3-12 |
| Punching | 3-13 |
| Detecting punch waste full | 3-14 |
| Detecting punch waste box | 3-14 |
| Functions of punch sensors/motors | 3-14 |
| Compiler unit assembly | 3-15 |
| Outline of operation | 3-15 |
| Capacity of compiler unit assembly | 3-16 |
| Compiler unit assembly operation with multiple media sizes | 3-16 |
| Tamping | 3-16 |
| Front tamping | 3-17 |
| Rear tamping | 3-18 |
| Center tamping | 3-19 |
| Determining tamper home position | 3-19 |
| Tamping | 3-19 |
| Offsetting | 3-20 |
| Functions of compiler unit assembly sensors/motors | 3-20 |
| Stapler | 3-21 |
| Stapling operation | 3-21 |
| Staple positions | 3-21 |
| Media sizes that allow stapling | 3-22 |
| Stapling one sheet | 3-22 |
| Stapling multiple size media | 3-22 |
| Media limits for stapling | 3-23 |
| Stapler operation | 3-23 |
| Stapler unit assembly | 3-24 |
| Functions of stapler sensors/motors | 3-24 |
| Upper media bin | 3-25 |
| Operation | 3-25 |
| Functions of upper media bin sensors | 3-25 |
| Stacker media bin | 3-26 |
| Operation | 3-26 |
| Full stack detection | 3-28 |
| Functions of stacker media bin sensors/motors | 3-28 |
| Power supply and interlock | 3-30 |

| | |
|--|------------|
| Repair information | 4-1 |
| Handling ESD-sensitive parts | 4-1 |
| Removal procedures | 4-2 |
| Bridge unit assembly removal | 4-2 |
| Finisher removal | 4-4 |
| Bridge unit rear cover removal | 4-6 |
| Bridge unit top cover assembly removal | 4-7 |
| Bridge unit drive belt and bridge unit drive pulley removal | 4-8 |
| Bridge unit right shaft assembly removal | 4-9 |
| Bridge unit left shaft assembly removal | 4-10 |
| Bridge unit idler rolls removal | 4-11 |
| Bridge unit transport belt removals | 4-12 |
| Bridge unit drive motor assembly removal | 4-13 |
| Bridge unit entrance guide removal | 4-14 |
| Sensor (bridge unit top cover interlock) removal | 4-15 |
| Sensor (bridge unit media entrance) removal | 4-16 |
| Sensor (bridge unit media exit) removal | 4-17 |
| Bridge unit pinch roller removal | 4-18 |
| Top cover removal | 4-19 |
| Upper media bin assembly removal | 4-20 |
| Right eject cover removal | 4-21 |
| Stacker media bin assembly removal | 4-22 |
| Right lower low voltage power supply (LVPS) cover removal | 4-22 |
| Rear lower cover removal | 4-23 |
| Rear upper cover removal | 4-24 |
| Upper media bin front cover removal | 4-25 |
| Switch (finisher front door interlock) removal | 4-26 |
| Finisher front door assembly removal | 4-27 |
| Left lower cover removal | 4-28 |
| Left upper cover removal | 4-29 |
| Carriage lift belt left removal | 4-30 |
| Carriage lift belt right removal | 4-32 |
| Sensor (stacker bin level 1) removal | 4-34 |
| Sensor (stacker bin level 2) removal | 4-34 |
| Sensor (stacker bin level encoder) removal | 4-35 |
| Sensor (stacker bin upper limit) or sensor (stacker bin no media) removal | 4-36 |
| Stacker bin lift motor assembly removal | 4-38 |
| Punch carriage assembly removal | 4-41 |
| Punch carriage shift motor assembly removal | 4-43 |
| Sensor (punch unit side registration pair) with bracket removal | 4-44 |
| Punch unit assembly removal | 4-45 |
| Punch media stop assembly removal | 4-46 |
| Punch unit motor assembly removal | 4-47 |
| Sensor (punch unit motor encoder) removal | 4-48 |
| Sensor (punch hole select), sensor (punch cam front), and sensor (punch unit HP) removal | 4-49 |
| Sensor (punch carriage shift HP) removal | 4-51 |
| Sensor (punch waste box set) removal | 4-52 |
| Sensor (punch waste box full) removal | 4-53 |
| Stapler unit frame removal | 4-54 |
| Stapler unit assembly removal | 4-56 |
| Sensor (stapler carriage HP) removal | 4-58 |
| Media eject unit assembly removal | 4-59 |
| Sub paddle removal | 4-63 |
| Sub paddle drive shaft assembly removal | 4-64 |
| Media eject clamp motor assembly removal | 4-66 |
| Sensor (media eject clamp HP) removal | 4-67 |
| Switch (eject cover interlock) removal | 4-68 |
| Media compiler unit assembly removal | 4-69 |
| Sensor (front tamper HP) and sensor (rear tamper HP) removals | 4-72 |

| | |
|--|------------|
| Sensor (compiler media in) removal | 4-73 |
| Media eject shaft assembly removal | 4-74 |
| Clamp paddle removal | 4-76 |
| Media eject clutch removal | 4-77 |
| Media eject motor assembly removal | 4-78 |
| Sensor (media eject shaft HP) removal | 4-79 |
| Sensor (lower media exit) removal | 4-80 |
| Lower media exit roll assembly removal | 4-82 |
| Paddle and roll exit assembly removal | 4-86 |
| Lower pinch guide assembly removal | 4-90 |
| Media diverter gate removal | 4-91 |
| Buffer diverter gate removal | 4-92 |
| Sensor (buffer path) removal | 4-93 |
| Buffer roll assembly removal | 4-94 |
| Buffer pinch guide assembly removal | 4-96 |
| Media entrance pinch guide assembly removal | 4-97 |
| Sensor (finisher media entrance) removal | 4-98 |
| Media entrance roll assembly removal | 4-99 |
| Drive motor (entrance/paddle) and belt (entrance/paddle) removal | 4-100 |
| Media diverter gate solenoid removal | 4-102 |
| Buffer diverter gate solenoid removal | 4-103 |
| Sensor (upper media exit) removal | 4-104 |
| Upper media exit pinch roll assembly removal | 4-105 |
| Upper media exit roll assembly removal | 4-106 |
| Sensor (upper media bin full) removal | 4-108 |
| Upper pinch guide assembly removal | 4-109 |
| Sensor (diverter gate) removal | 4-110 |
| Upper media transport roll assembly removal | 4-111 |
| Drive motor (exit) assembly and belt (exit) removal | 4-113 |
| Drive motor (buffer/transport) and belt (buffer/transport) removal | 4-115 |
| Bridge unit interface card assembly removal | 4-117 |
| Finisher controller card assembly removal | 4-118 |
| Finisher low voltage power supply (LVPS) removal | 4-119 |
| Component locations | 5-1 |
| Locations | 5-1 |
| Bridge unit assembly | 5-1 |
| Stacker lift and stapler | 5-2 |
| Punch unit | 5-3 |
| Diverter and media eject | 5-4 |
| Media eject and media compiler | 5-5 |
| Buffer, upper exit, lower exit, and drive motors | 5-6 |
| Cabling | 5-7 |
| Electronic component diagram | 5-10 |
| Preventive maintenance | 6-1 |
| Safety inspection guide | 6-1 |
| Maintenance recommendations | 6-1 |

Parts catalog **7-1**

- How to use this parts catalog 7-1
- Assembly 1: Bridge unit 7-2
- Assembly 2: Bridge unit top cover assembly 7-3
- Assembly 3: Bridge unit lower assembly 7-4
- Assembly 4: Covers 7-6
- Assembly 5: Covers and front door 7-8
- Assembly 6: Stacker bin lift 7-10
- Assembly 7: Punch 7-12
- Assembly 8: Stapler 7-14
- Assembly 9: Media eject 7-16
- Assembly 10: Eject and compiler unit 7-18
- Assembly 11: Lower exit drive 7-20
- Assembly 12: Buffer and entrance drive 7-22
- Assembly 13: Buffer, transport, and upper drive 7-24
- Assembly 14: Electronics 7-26
- Assembly 15: Cables 1 7-28
- Assembly 16: Cables 2 7-30
- Assembly 17: Cables 3 7-31

Index **I-1**

Part number index **I-7**

Notices and safety information

Laser notice

The printer is certified in the U.S. to conform to the requirements of DHHS 21 CFR Subchapter J for Class I (1) laser products, and elsewhere is certified as a Class I laser product conforming to the requirements of IEC 60825-1.

Class I laser products are not considered to be hazardous. The printer contains internally a Class IIIb (3b) laser that is nominally a 5 milliwatt gallium arsenide laser operating in the wavelength region of 770-795 nanometers. The laser system and printer are designed so there is never any human access to laser radiation above a Class I level during normal operation, user maintenance, or prescribed service condition.

Laser

Der Drucker erfüllt gemäß amtlicher Bestätigung der USA die Anforderungen der Bestimmung DHHS (Department of Health and Human Services) 21 CFR Teil J für Laserprodukte der Klasse I (1). In anderen Ländern gilt der Drucker als Laserprodukt der Klasse I, der die Anforderungen der IEC (International Electrotechnical Commission) 60825-1 gemäß amtlicher Bestätigung erfüllt.

Laserprodukte der Klasse I gelten als unschädlich. Im Inneren des Druckers befindet sich ein Laser der Klasse IIIb (3b), bei dem es sich um einen Galliumarsenlaser mit 5 Milliwatt handelt, der Wellen der Länge 770-795 Nanometer ausstrahlt. Das Lasersystem und der Drucker sind so konzipiert, daß im Normalbetrieb, bei der Wartung durch den Benutzer oder bei ordnungsgemäßer Wartung durch den Kundendienst Laserbestrahlung, die Klasse I übersteigen würde, Menschen keinesfalls erreicht.

Avis relatif à l'utilisation de laser

Pour les Etats-Unis : cette imprimante est certifiée conforme aux provisions DHHS 21 CFR alinéa J concernant les produits laser de Classe I (1). Pour les autres pays : cette imprimante répond aux normes IEC 60825-1 relatives aux produits laser de Classe I.

Les produits laser de Classe I sont considérés comme des produits non dangereux. Cette imprimante est équipée d'un laser de Classe IIIb (3b) (arséniure de gallium d'une puissance nominale de 5 milliwatts) émettant sur des longueurs d'onde comprises entre 770 et 795 nanomètres. L'imprimante et son système laser sont conçus pour impossible, dans des conditions normales d'utilisation, d'entretien par l'utilisateur ou de révision, l'exposition à des rayonnements laser supérieurs à des rayonnements de Classe I.

Avvertenze sui prodotti laser

Questa stampante è certificata negli Stati Uniti per essere conforme ai requisiti del DHHS 21 CFR Sottocapitolo J per i prodotti laser di classe 1 ed è certificata negli altri Paesi come prodotto laser di classe 1 conforme ai requisiti della norma CEI 60825-1.

I prodotti laser di classe non sono considerati pericolosi. La stampante contiene al suo interno un laser di classe IIIb (3b) all'arseniuro di gallio della potenza di 5mW che opera sulla lunghezza d'onda compresa tra 770 e 795 nanometri. Il sistema laser e la stampante sono stati progettati in modo tale che le persone a contatto con la stampante, durante il normale funzionamento, le operazioni di servizio o quelle di assistenza tecnica, non ricevano radiazioni laser superiori al livello della classe 1.

Avisos sobre el láser

Se certifica que, en los EE.UU., esta impresora cumple los requisitos para los productos láser de Clase I (1) establecidos en el subcapítulo J de la norma CFR 21 del DHHS (Departamento de Sanidad y Servicios) y, en los demás países, reúne todas las condiciones expuestas en la norma IEC 60825-1 para productos láser de Clase I (1).

Los productos láser de Clase I no se consideran peligrosos. La impresora contiene en su interior un láser de Clase IIIb (3b) de arseniuro de galio de funcionamiento nominal a 5 milivatios en una longitud de onda de 770 a 795 nanómetros. El sistema láser y la impresora están diseñados de forma que ninguna persona pueda verse afectada por ningún tipo de radiación láser superior al nivel de la Clase I durante su uso normal, el mantenimiento realizado por el usuario o cualquier otra situación de servicio técnico.

Declaração sobre Laser

A impressora está certificada nos E.U.A. em conformidade com os requisitos da regulamentação DHHS 21 CFR Subcapítulo J para a Classe I (1) de produtos laser. Em outros locais, está certificada como um produto laser da Classe I, em conformidade com os requisitos da norma IEC 60825-1.

Os produtos laser da Classe I não são considerados perigosos. Internamente, a impressora contém um produto laser da Classe IIIb (3b), designado laser de arseneto de potássio, de 5 milliwatts, operando numa faixa de comprimento de onda entre 770 e 795 nanómetros. O sistema e a impressora laser foram concebidos de forma a nunca existir qualquer possibilidade de acesso humano a radiação laser superior a um nível de Classe I durante a operação normal, a manutenção feita pelo utilizador ou condições de assistência prescritas.

Laserinformatie

De printer voldoet aan de eisen die gesteld worden aan een laserproduct van klasse I. Voor de Verenigde Staten zijn deze eisen vastgelegd in DHHS 21 CFR Subchapter J, voor andere landen in IEC 60825-1.

Laserprodukten van klasse I worden niet als ongevaarlijk aangemerkt. De printer is voorzien van een laser van klasse IIIb (3b), dat wil zeggen een gallium arsenide-laser van 5 milliwatt met een golflengte van 770-795 nanometer. Het lasergedeelte en de printer zijn zo ontworpen dat bij normaal gebruik, bij onderhoud of reparatie conform de voorschriften, nooit blootstelling mogelijk is aan laserstraling boven een niveau zoals voorgeschreven is voor klasse 1.

Lasermeddelelse

Printeren er godkendt som et Klasse I-laserprodukt, i overensstemmelse med kravene i IEC 60825-1.

Klasse I-laserprodukter betragtes ikke som farlige. Printeren indeholder internt en Klasse IIIB (3b)-laser, der nominelt er en 5 milliwatt galliumarsenid laser, som arbejder på bølglængdeområdet 770-795 nanometer. Lasersystemet og printeren er udformet således, at mennesker aldrig udsættes for en laserstråling over Klasse I-niveau ved normal drift, brugervedligeholdelse eller obligatoriske servicebetingelser.

Huomautus laserlaitteesta

Tämä kirjoitin on Yhdysvalloissa luokan I (1) laserlaitteiden DHHS 21 CFR Subchapter J -määrityksen mukainen ja muualla luokan I laserlaitteiden IEC 60825-1 -määrityksen mukainen.

Luokan I laserlaitteiden ei katsota olevan vaarallisia käyttäjälle. Kirjoittimessa on sisäinen luokan IIIb (3b) 5 milliwatin galliumarsenidilaser, joka toimii aaltoalueella 770 - 795 nanometriä. Laserjärjestelmä ja kirjoitin on suunniteltu siten, että käyttäjä ei altistu luokan I määräyksiä voimakkaammalle säteilylle kirjoittimen normaalin toiminnan, käyttäjän tekemien huoltotoimien tai muiden huoltotoimien yhteydessä.

VARO! Avattaessa ja suojalukitus ohitettaessa olet alttiina näkymättömälle lasersäteilylle. Älä katso säteeseen.

VARNING! Osynlig laserstrålning när denna del är öppnad och spärren är urkopplad. Betrakta ej strålen.

Laser-notis

Denna skrivare är i USA certifierad att motsvara kraven i DHHS 21 CFR, underparagraf J för laserprodukter av Klass I (1). I andra länder uppfyller skrivaren kraven för laserprodukter av Klass I enligt kraven i IEC 60825-1.

Laserprodukter i Klass I anses ej hälsovådliga. Skrivaren har en inbyggd laser av Klass IIIb (3b) som består av en laserenhet av gallium-arsenid på 5 milliwatt som arbetar i våglängdsområdet 770-795 nanometer.

Lasersystemet och skrivaren är utformade så att det aldrig finns risk för att någon person utsätts för laserstrålning över Klass I-nivå vid normal användning, underhåll som utförs av användaren eller annan föreskriven serviceåtgärd.

Laser-melding

Skriveren er godkjent i USA etter kravene i DHHS 21 CFR, underkapittel J, for klasse I (1) laserprodukter, og er i andre land godkjent som et Klasse I-laserprodukt i samsvar med kravene i IEC 60825-1.

Klasse I-laserprodukter er ikke å betrakte som farlige. Skriveren inneholder internt en klasse IIIb (3b)-laser, som består av en gallium-arsenlaserenhet som avgir stråling i bølglengdeområdet 770-795 nanometer.

Lasersystemet og skriveren er utformet slik at personer aldri utsettes for laserstråling ut over klasse I-nivå under vanlig bruk, vedlikehold som utføres av brukeren, eller foreskrevne serviceoperasjoner.

Avís sobre el Làser

Segons ha estat certificat als Estats Units, aquesta impressora compleix els requisits de DHHS 21 CFR, apartat J, pels productes làser de classe I (1), i segons ha estat certificat en altres llocs, és un producte làser de classe I que compleix els requisits d'IEC 60825-1.

Els productes làser de classe I no es consideren perillosos. Aquesta impressora conté un làser de classe IIIb (3b) d'arseniür de gal.li, nominalment de 5 mil.liwats, i funciona a la regió de longitud d'ona de 770-795 nanòmetres. El sistema làser i la impressora han sigut concebuts de manera que mai hi hagi exposició a la radiació làser per sobre d'un nivell de classe I durant una operació normal, durant les tasques de manteniment d'usuari ni durant els serveis que satisfacin les condicions prescrites.

レーザーに関するお知らせ

このプリンターは、米国ではDHHS 21 CFRサブチャプターJのクラスI(1)の基準を満たしたレーザー製品であることが証明されています。また米国以外ではIEC 825の基準を満たしたクラスIのレーザー製品であることが証明されています。

クラスIのレーザー製品には危険性はないと考えられています。このプリンターはクラスIII b(3b)のレーザーを内蔵しています。このレーザーは、波長が770 ~ 795ナノメートルの範囲で、通常5ミリワットのガリウム砒化物を放射するレーザーです。このレーザーシステムとプリンターは、通常の操作、ユーザのメンテナンス、規定された修理においては、人体がクラスIのレベル以上のレーザー放射に晒されることのないよう設計されています。

注意：

本打印机被美国认证合乎 DHHS 21 CFR Subchapter I 对分类 I (1) 激光产品的标准，而在其他地区则被认证合乎 IEC 825 的标准。

分类 I 激光产品一般认为不具危险性，本打印机内部含有分类 IIIb (3b) 的激光，在操作过程中会产生 5 毫瓦含镓及砷的微量激光，其波长范围在 770-795 nm 之间。本激光系统及打印机的设计，在一般操作、使用者维护或规定内的维修情况下，不会使人体接触分类 I 以上等级的辐射。

본프린터는 1등급 레이저 제품들에 대한 DHHS 21 CFR Subchapter 3의 규정을 준수하고 있음을 미국에서 인증받았으며, 그외의 나라에서도 IEC 825 규정을 준수하는 1등급 레이저 제품으로서 인증을 받았습니다.

1등급 레이저 제품들은 안전한 것으로 간주됩니다. 본 프린터는 5 밀리วัต 갈륨 아르세나이드 레이저로서 770-795 나노미터의 파장대에서 활동하는 Class III (3b) 레이저를 내부에 갖고 있습니다. 본 레이저 시스템과 프린터는 정상 작동 중이나 유지 보수 중 또는 규정된 서비스 상태에서 상기의 Class I 수준의 레이저 방출에 사람이 절대 접근할 수 없도록 설계되어 있습니다.

Safety information

- The safety of this product is based on testing and approvals of the original design and specific components. The manufacturer is not responsible for safety in the event of use of unauthorized replacement parts.
- The maintenance information for this product has been prepared for use by a professional service person and is not intended to be used by others.
- There may be an increased risk of electric shock and personal injury during disassembly and servicing of this product. Professional service personnel should understand this and take necessary precautions.
-  **CAUTION:** When you see this symbol, there is a danger from hazardous voltage in the area of the product where you are working. Unplug the product before you begin, or use caution if the product must receive power in order to perform the task.

Consignes de sécurité

- La sécurité de ce produit repose sur des tests et des agrégations portant sur sa conception d'origine et sur des composants particuliers. Le fabricant n'assume aucune responsabilité concernant la sécurité en cas d'utilisation de pièces de rechange non agréées.
- Les consignes d'entretien et de réparation de ce produit s'adressent uniquement à un personnel de maintenance qualifié.
- Le démontage et l'entretien de ce produit pouvant présenter certains risques électriques, le personnel d'entretien qualifié devra prendre toutes les précautions nécessaires.
-  **ATTENTION :** Ce symbole indique la présence d'une tension dangereuse dans la partie du produit sur laquelle vous travaillez. Débranchez le produit avant de commencer ou faites preuve de vigilance si l'exécution de la tâche exige que le produit reste sous tension.

Norme di sicurezza

- La sicurezza del prodotto si basa sui test e sull'approvazione del progetto originale e dei componenti specifici. Il produttore non è responsabile per la sicurezza in caso di sostituzione non autorizzata delle parti.
- Le informazioni riguardanti la manutenzione di questo prodotto sono indirizzate soltanto al personale di assistenza autorizzato.
- Durante lo smontaggio e la manutenzione di questo prodotto, il rischio di subire scosse elettriche e danni alla persona è più elevato. Il personale di assistenza autorizzato deve, quindi, adottare le precauzioni necessarie.
-  **ATTENZIONE:** Questo simbolo indica la presenza di tensione pericolosa nell'area del prodotto. Scollegare il prodotto prima di iniziare o usare cautela se il prodotto deve essere alimentato per eseguire l'intervento.

Sicherheitshinweise

- Die Sicherheit dieses Produkts basiert auf Tests und Zulassungen des ursprünglichen Modells und bestimmter Bauteile. Bei Verwendung nicht genehmigter Ersatzteile wird vom Hersteller keine Verantwortung oder Haftung für die Sicherheit übernommen.
- Die Wartungsinformationen für dieses Produkt sind ausschließlich für die Verwendung durch einen Wartungsfachmann bestimmt.
- Während des Auseinandernehmens und der Wartung des Geräts besteht ein zusätzliches Risiko eines elektrischen Schlags und körperlicher Verletzung. Das zuständige Fachpersonal sollte entsprechende Vorsichtsmaßnahmen treffen.
-  **ACHTUNG:** Dieses Symbol weist auf eine gefährliche elektrische Spannung hin, die in diesem Bereich des Produkts auftreten kann. Ziehen Sie vor den Arbeiten am Gerät den Netzstecker des Geräts, bzw. arbeiten Sie mit großer Vorsicht, wenn das Produkt für die Ausführung der Arbeiten an den Strom angeschlossen sein muß.

Pautas de Seguridad

- La seguridad de este producto se basa en pruebas y aprobaciones del diseño original y componentes específicos. El fabricante no es responsable de la seguridad en caso de uso de piezas de repuesto no autorizadas.
- La información sobre el mantenimiento de este producto está dirigida exclusivamente al personal cualificado de mantenimiento.
- Existe mayor riesgo de descarga eléctrica y de daños personales durante el desmontaje y la reparación de la máquina. El personal cualificado debe ser consciente de este peligro y tomar las precauciones necesarias.
-  **PRECAUCIÓN:** este símbolo indica que el voltaje de la parte del equipo con la que está trabajando es peligroso. Antes de empezar, desenchufe el equipo o tenga cuidado si, para trabajar con él, debe conectarlo.

Informações de Segurança

- A segurança deste produto baseia-se em testes e aprovações do modelo original e de componentes específicos. O fabricante não é responsável pela segurança, no caso de uso de peças de substituição não autorizadas.
- As informações de segurança relativas a este produto destinam-se a profissionais destes serviços e não devem ser utilizadas por outras pessoas.
- Risco de choques eléctricos e ferimentos graves durante a desmontagem e manutenção deste produto. Os profissionais destes serviços devem estar avisados deste facto e tomar os cuidados necessários.
-  **CUIDADO:** Quando vir este símbolo, existe a possível presença de uma potencial tensão perigosa na zona do produto em que está a trabalhar. Antes de começar, desligue o produto da tomada eléctrica ou seja cuidadoso caso o produto tenha de estar ligado à corrente eléctrica para realizar a tarefa necessária.

Informació de Seguretat

- La seguretat d'aquest producte es basa en l'avaluació i aprovació del disseny original i els components específics.
El fabricant no es fa responsable de les qüestions de seguretat si s'utilitzen peces de recanvi no autoritzades.
- La informació pel manteniment d'aquest producte està orientada exclusivament a professionals i no està destinada a ningú que no ho sigui.
- El risc de xoc elèctric i de danys personals pot augmentar durant el procés de desmuntatge i de servei d'aquest producte. El personal professional ha d'estar-ne assabentat i prendre les mesures convenients.
-  **PRECAUCIÓ:** aquest símbol indica que el voltatge de la part de l'equip amb la qual esteu treballant és perillós. Abans de començar, desendolleu l'equip o extremeu les precaucions si, per treballar amb l'equip, l'heu de connectar.

안전 사항

- 본 제품은 원래 설계 및 특정 구성품에 대한 테스트 결과로 안정성이 입증된 것입니다. 따라서 무허가 교체부품을 사용하는 경우에는 제조업체에서 안전에 대한 책임을 지지 않습니다.
- 본 제품에 관한 유지 보수 설명서는 전문 서비스 기술자용으로 작성된 것이므로, 비전문가는 사용할 수 없습니다.
- 본 제품을 해체하거나 정비할 경우, 전기적인 충격을 받거나 상처를 입을 위험이 커집니다. 전문 서비스 기술자는 이 사실을 숙지하고, 필요한 예방 조치를 취하도록 하십시오.
-  **주의:** 이 표시는 해당영역에서 고압전류가 흐른다는 위험 표시입니다. 시작전에 플러그를 뽑으시거나, 주의를 기울여 주시기 바랍니다.

安全信息

- 本产品的安全性以原来设计和特定产品的测试结果和认证为基础。万一使用未经许可的替换部件，制造商不对安全性负责。
- 本产品的维护信息仅供专业服务人员使用，并不打算让其他人使用。
- 本产品在拆卸、维修时，遭受电击或人员受伤的危险性会增高，专业服务人员对这点必须有所了解，并采取必要的预防措施。
-  **切记:** 当您看到此符号时，说明在您工作的产品区域有危险电压的存在。请在开始操作前拔掉产品的电源线，或者在产品必须使用电源来执行任务时，小心从事。

Preface

The service information for the Lexmark W840 is contained within three service manuals:

- *Printer Service Manual*—Contains the base printer service information including the options and finisher error codes and tests.
- *Options Service Manual*—Contains specific information for the 2 Tray Module, Tandem Tray Module, Duplex, High Capacity Feeder and Exit 2 options and a list of error codes and tests.
- *Finisher Service Manual*—Contains specific information for the Finisher option list of error codes and tests.

These manuals contain maintenance procedures for service personnel. They are divided into the following chapters:

1. **General information** contains a general description of the printer and the maintenance approach used to repair it. Special tools and test equipment are, as well as general environmental and safety instructions.
2. **Diagnostic information** contains an error code messages table and service checks used to isolate failing field replaceable units (FRUs).
3. **Diagnostic aids** contains tests and checks used to locate or repeat symptoms of printer problems.
4. **Repair information** provides instructions for making printer adjustments and removing and installing FRUs.
5. **Component locations** uses illustrations to identify the connector locations and test points on the printer.
6. **Preventive maintenance** contains the lubrication specifications and recommendations to prevent problems.
7. **Parts catalog** contains illustrations and part numbers for individual FRUs.

Definitions

Note: A note provides additional information.

Warning: A warning identifies something that might damage the product hardware or software.

CAUTION: A caution identifies something that might cause a servicer harm.



CAUTION: When you see this symbol, there is a danger from hazardous voltage in the area of the product where you are working. Unplug the product before you begin, or use caution if the product must receive power in order to perform the task.

1. General information

The optional finisher performs staples, punches, and stacks media transferred from the Lexmark™ W840 printer. Output is stacked in the upper media bin or separately collated in the stacker media bin.

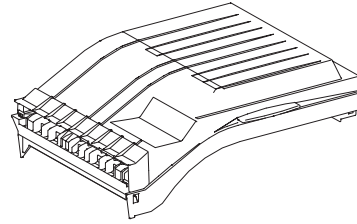

Bridge unit assembly

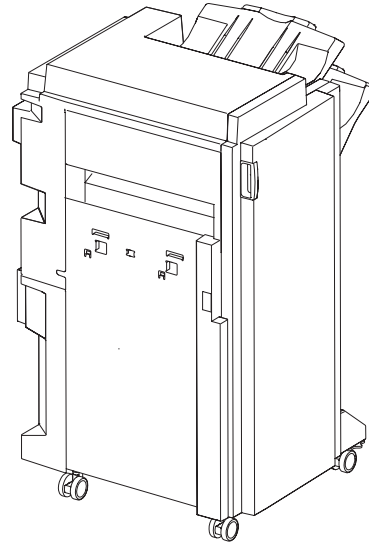

Finisher

Finisher weight

Packaged: 42 kg

Unpackaged: 30 kg

Components

The finisher is composed of the following five components.

- Bridge unit assembly block to feed media from the printer to the finisher
- Punch block to punch media
- Compiler tray block to align media
- Stapler block to staple a set of media at specified positions

- Stacker media bin block to stack media

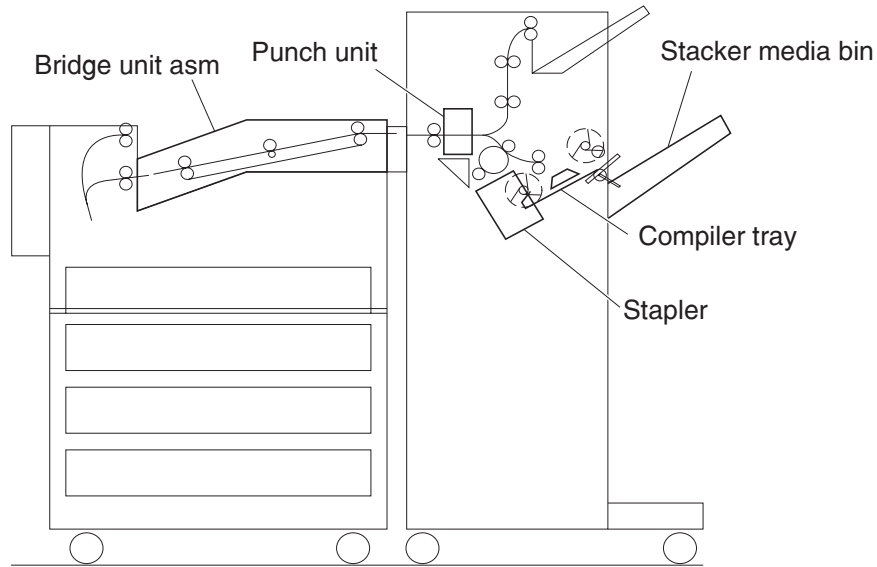

Media size and weight

The following shows media sizes and weight that the finisher can handle, as well as applicable functions for each media size.

The printer and the finisher handle different media sizes and weights. For this reason, if the printer has printed media that the finisher cannot handle, the exit 1 diverter gate in the printer is switched to eject the media from Exit 2 onto the bridge unit assembly. Refer to the *Printer Service Manual* for additional information on the printer.

Media size/orientation and applicable functions

| Media description | Size | Short edge first (SEF)/ Long edge first (LEF) | Top tray | Stacker | | | |
|-------------------|-----------------------------------|--|----------|---------|--------------|-------------------------|--------|
| | | | Stack | Stack | Offset stack | Punch ¹ | Staple |
| B5 | 182 x 257 mm | SEF | Yes | No | No | No | No |
| | | LEF | Yes | Yes | Yes | Yes ^{a(2)} | Yes |
| Executive | 7.25 x 10.5 in. 184.2 x 270 mm | SEF | Yes | No | No | No | No |
| | | LEF | Yes | Yes | Yes | Yes ^{a(2,3,4)} | No |
| Letter | 8.5 x 11 in. 215.9 x 279.4 mm | SEF | Yes | Yes | Yes | Yes ^{a(2)} | Yes |
| | | LEF | Yes | Yes | Yes | Yes ^{a(2,3,4)} | Yes |
| A4 | 210 x 297 | SEF | Yes | Yes | Yes | Yes ^{a(2)} | Yes |
| | | LEF | Yes | Yes | Yes | Yes ^{2,a(3,4)} | Yes |
| Folio (foolscap) | 8,5 x 13 in. | SEF | Yes | Yes | Yes | Yes ^{a(2)} | Yes |
| Legal | 8.5 x 14 in. | SEF | Yes | Yes | Yes | Yes ^{a(2)} | Yes |
| B4 | 257 x 364 mm | SEF | Yes | Yes | Yes | Yes ^{a(2)} | Yes |

| | | | | | | | |
|---|-------------------------------|-----|-----|------------------|------------------|-------------------------|-----|
| A3 | 297 x 420 mm | SEF | Yes | Yes | Yes | Yes ^{a(2,3,4)} | Yes |
| Ledger | 11 x 17 in. | SEF | Yes | Yes | Yes | Yes ^{a(2,3,4)} | Yes |
| Custom size | Same width with standard size | | Yes | Yes | Yes | Yes | Yes |
| Custom size | Besides above | | Yes | Yes ^b | Yes ^b | No | No |
| <p>^a Numbers (2,3,4) mean 2 holes, 3 holes, and 4 holes, respectively.</p> <p>^b Applicable within the following range: Media width: 203.2–297 mm Media length: 182–431.8 mm</p> | | | | | | | |

Media weight

| Description | Maximum weight |
|---|----------------|
| For punching | 52—176 gsm |
| For stapling | 52—226 gsm* |
| For ejecting in the stacker media bin | 52—226 gsm |
| For ejecting in the upper media bin | 52—226 gsm |
| * The amount of media capable of being stapled will be less than 50 if media weight is greater than 90 gsm. | |

Tools required for service

- Flat-blade screwdriver
- #1 Phillips screwdriver, magnetic
- #2 Phillips screwdriver, magnetic
- #2 Phillips screwdriver, magnetic short-blade
- Needlenose pliers
- Diagonal side cutters
- Spring hook
- Analog or digital multimeter

Features

| Media processing requested | Destination of media |
|----------------------------|--------------------------------------|
| No post-processing | Upper media bin or stacker media bin |
| Punching | Upper media bin or stacker media bin |
| Stapling | Stacker media bin |
| Punching and stapling | Stacker media bin |

Acronyms

| | |
|-------|---|
| 2TM | 2 Tray Module |
| AC | Alternate Current |
| ASIC | Application Specific Intergrated Circuit |
| CRU | Customer Replaceable Unit |
| CSU | Customer Setup |
| DC | Direct Current |
| DIMM | Dual Inline Memory Module |
| DRAM | Dynamic Random Access Memory |
| EDO | Enhanced Data Out |
| EP | Electrophotographic Process |
| EPROM | Erasable Programmable Read-only Memory |
| ESD | Electrostatic Discharge |
| FRU | Field Replaceable Unit |
| GB | Gigabyte |
| GFI | Ground Fault Interrupter |
| HCF | High-Capacity Feeder |
| HVPS | High Voltage Power Supply |
| LASER | Light Amplification by Stimulated Emission of Radiation |
| LCD | Liquid Crystal Display |
| LD | Laser Diode |
| LED | Light-Emitting Diode |
| LEF | Long Edge Fed |
| LVPS | Low Voltage Power Supply |
| MPF | Multi-Purpose Feeder |
| MS | Microswitch |
| NVM | Nonvolatile Memory |
| NVRAM | Nonvolatile Random Access Memory |
| OEM | Original Equipment Manufacturer |
| OPT | Optical Sensor |
| PC | Photoconductor |
| pel | Picture element |
| POR | Power-on Reset |
| POST | Power-on Self Test |
| PPM | Pages Per Minute |
| PSC | Parallel Synchronous Communications |
| PSD | Position Sensing Device |
| PWM | Pulse Width Modulation |
| RFID | Radio Frequency Identification |
| RIP | Raster Imaging Processor |
| ROM | Read only Memory |
| RPM | Parallel Synchronous Communications |
| SDRAM | Synchronous Dual Random Access Memory |
| SEF | Short Edge Fed |
| SIMM | Single Inline Memory Module |
| SOS | Start of scan |
| SRAM | Static Random Access Memory |
| TTM | Tandem Tray Module |
| UPR | Used Parts Return |
| V | Volts |
| V ac | Volts alternating current |
| V dc | Volts direct current |

4024-XXX

2. Diagnostic information

Start



CAUTION: Unplug power cord from the printer or electrical outlet before you connect or disconnect any cable or electronic board or assembly for personal safety and to prevent damage to the printer. Disconnect any connections between the printer and PCs/peripherals. The printer and the finisher are heavy and require at least two people to lift it safely. Make sure your fingers are not under the printer when you lift or set the printer down.

CAUTION: If the printer is kept on, never touch the conductive parts while it is not specifically required. The power switch and inlet of the low voltage power supply card (LVPS card) assembly is live even while the power supply is cut off. Never touch the live parts.

Warning: When operating the driving units using the diagnostics or other tools, be sure to keep them covered unless otherwise specified.

Warning: When operating the driving units using the diagnostics or other tools, never touch the driving units. When operating the driving units using diagnostics or other tools, be sure to follow the procedures in this manual.

CAUTION: Be careful to avoid burns by safely handling hot parts.

Warning: Servicers should wear a wrist band or the like to remove static electricity from their body, grounding their body while working. See **“Handling ESD-sensitive parts” on page 4-1.**

Using service checks

It is assumed in the finisher service checks that the printer controller RIP card assembly is normally functioning. If any trouble cannot be corrected by troubleshooting, refer to the *Printer Service Manual*.

To determine the corrective action necessary to repair a finisher, look for the following information:

- Verify **“Confirm the installation status” on page 2-2**
- Go to the **“Error code messages” on page 2-3.**
- Additional information can be found at:
 - **“Service checks” on page 2-11.**
 - **“Theory” on page 3-4**

Note: There may be printer error messages that are not contained in this service manual. Call your next level support for assistance.

Confirm the installation status

Be sure to check the following items before starting the troubleshooting procedures

- With the power cord removed from the printer, check that it is free from breakage, short-circuit, disconnected wire, or incorrect connection in the power cord.
- The printer is properly grounded. Check the power cord ground terminal.
- The printer is not installed at a place subjected to extreme temperature, or extreme humidity, or rapid changes in temperature.
- The printer is not installed close to water service, humidifier, heat generating unit, fire, in a very dusty place, or a place exposed to air flow from the air conditioning system.
- The printer is not installed in a place where volatile gas or inflammable gas is generated.
- The printer is not installed in direct sun.
- The printer is installed on a stout and stable surface.
- Media meets specifications and is installed properly.
- Customer maintenance parts have been replaced at the specified intervals.
- Check all attached options for proper attachment and electrical connection.
- Refer to the *User's Guide* for proper installation.

Error code messages

| Error code or message | Error contents | Description/action |
|-------------------------------------|--|--|
| 280.00 Paper jam Check area A | Sensor (bridge unit media entrance) on jam | Sensor (bridge unit media entrance) is not turned on within the specified time after the sensor (fuser exit) in the printer is turned on. Go to “280.00 Sensor (bridge unit media entrance) on Jam” on page 2-11. |
| 280.01 Paper jam Check area A | Sensor (bridge unit media entrance) Static jam A | Paper remains on the sensor (bridge unit media entrance). Go to “280.01 Sensor (bridge unit media entrance) static jam A” on page 2-12. |
| 280.02 Check area F | Sensor (bridge unit media entrance) Static jam B | Paper remains on the sensor (bridge unit media entrance). Go to “280.02 Sensor (bridge unit media entrance) static jam B” on page 2-13. |
| 281.00 Paper jam Check area A | Sensor (bridge unit media exit) on jam A | Sensor (bridge unit media exit) is not turned on within the specified time after the sensor (bridge unit media entrance) turned on. At this time, the sensor (fuser exit) in the printer is turned on. Go to “281.00 Sensor (bridge unit media exit) On Jam A” on page 2-14. |
| 281.01 Paper jam Check area F | Sensor (bridge unit media exit) on jam B | Sensor (bridge unit media exit) is not turned on within the specified time after the sensor (bridge unit media entrance) turned on. At this time, the sensor (bridge unit media entrance) is turned on. Go to “281.01 Sensor (bridge unit media exit) On Jam B” on page 2-15. |
| 281.02 Paper jam Check area F | Sensor (Bridge unit media exit) on jam C | Sensor (bridge unit media exit) is not turned on within the specified time after the sensor (bridge unit media entrance) is turned on. Go to “281.02 Sensor (bridge unit media exit) On Jam C” on page 2-17. |
| 281.03 Paper jam Check area F | Sensor (bridge unit media exit) Static jam A | Paper remains on the sensor (bridge unit media exit). Go to “281.03 Sensor (bridge unit media exit) static jam A” on page 2-18. |
| 282.00 Paper jam Check area F | Sensor (finisher media entrance) on jam | Sensor (finisher media entrance) is not turned on with the specified time after the sensor (bridge unit media exit) is turned on. Go to “282.00 Sensor (finisher media entrance) on jam” on page 2-19. |
| 282.01 Paper jam Check area F | Sensor (finisher media entrance) Static jam A | Paper remains on the sensor (finisher media entrance). At this time, the sensor (bridge unit media exit) is turned on. Go to “282.01 Sensor (finisher media entrance) static jam A” on page 2-21. |

| | | |
|---|-------------------------------------|---|
| 283.00 Paper jam Check areas G, G4 | Sensor (buffer path) on jam A | Sensor (buffer path) is not turned on within the specified time after the sensor (finisher media entrance) is turned on. Go to “283.00 Sensor (buffer path) on jam A” on page 2-22. |
| 283.01 Paper jam Check area G2 | Sensor (buffer path) on jam B | Sensor (buffer path) is not turned on within the specified time after the sensor (finisher media entrance) is turned on. At this time, the sensor (diverter gate) is turned on. Go to “283.01 Sensor (buffer path) on jam B” on page 2-24. |
| 283.02 Paper jam Check areas G2, G3 | Sensor (buffer path) Static jam A | Paper remains on the sensor (finisher buffer path). At this time, both sensor (diverter gate) and sensor (transport exit) are turned on. Go to “283.02 Sensor (buffer path) static jam A” on page 2-26. |
| 283.03 Paper jam Check area G2 | Sensor (buffer path) Static jam B | Paper remains on the sensor (finisher buffer path). At this time, the sensor (diverter gate) is on state, but the sensor (finisher media entrance) is turned off. Go to “283.03 Sensor (buffer path) static jam B” on page 2-27. |
| 283.04 Paper jam Check area G4 | Sensor (buffer path) Static jam C | Paper remains on the sensor (finisher buffer path). At this time, the sensor (diverter gate) is turned off. Go to “283.04 Sensor (buffer path) static jam C” on page 2-28. |
| 284.00 Paper jam Check area F | Sensor (lower media exit) off jam A | Sensor (lower media exit) is not turned off within the specified time after the finisher sensor (lower media exit) is on. At this time, the sensor (bridge unit media exit) is turned on. Go to “284.00 Sensor (lower media exit) off jam A.” on page 2-28. |
| 284.01 Paper jam Check area F | Sensor (lower media exit) on jam A | Sensor (buffer path) is not turned on within the specified time after the sensor (finisher media entrance) is turned on. At this time the sensor (bridge unit media exit) is turned on. Go to “284.01 Sensor (lower media exit) on jam A” on page 2-30. |
| 284.02 Paper jam Check areas G2, G3 | Sensor (lower media exit) on jam B | Sensor (buffer path) is not turned on within the specified time after the sensor (bridge unit media entrance) is turned on. At this time, the sensor (finisher media entrance) is turned on. Go to “284.02 Sensor (lower media exit) on jam B” on page 2-32. |
| 284.03 Paper jam Check area G2 | Sensor (lower media exit) on jam C | Finisher sensor (lower media exit) not turned on within the specified time after the sensor (buffer path) is turned on. Go to “284.03 Sensor (lower media exit) on jam C” on page 2-34. |

| | | |
|---|---------------------------------------|--|
| 284.04 Paper jam Check area H | Sensor (lower media exit) off jam B | Finisher sensor (lower media exit) not turned off within the specified time after the finisher sensor (lower media exit) on. At this time, the sensor (finisher media entrance) is turned on. Go to “284.04 Sensor (lower media exit) off jam B.” on page 2-36. |
| 284.05 Paper jam Check areas H, G3 | Sensor (lower media exit) Static jam | Paper remains on the sensor (lower media exit). Go to “284.05 Sensor (lower media exit) static jam” on page 2-37. |
| 285.00 Paper jam Check area H | Finisher eject set jam | Finisher sensor (compiler media in) is not turned on within the specified time after the media eject motor is turned on. Go to “285.00 Finisher eject set jam” on page 2-37. |
| 286.00 Paper jam Check area H | Sensor (compiler media in) Static jam | Paper remains on the sensor (compiler media in). Go to “286.00 Sensor (compiler media in) static jam” on page 2-38. |
| 287.00 Check area F | Sensor (upper media exit) on jam A | Sensor (upper media exit) is not turned on within the specified time after the sensor (finisher media entrance) is turned on. At this time, the sensor (bridge unit media exit) is turned on. Go to “287.00 Sensor (upper media exit) on jam A” on page 2-40. |
| 287.01 Check area F | Sensor (upper media exit) off jam A | Sensor (upper media exit) is not turned off within the specified time after the sensor (upper media exit) is turned on. At this time, the sensor (bridge unit media exit) is turned on. Go to “287.01 Sensor (upper media exit) off jam A.” on page 2-41. |
| 287.02 Paper jam Check areas G1, G3 | Sensor (upper media exit) on jam B | Sensor (upper media exit) is not turned on within the specified time after the sensor (finisher media entrance) is turned on. At this time, the sensor (bridge unit media exit) is turned on. Go to “287.02 Sensor (upper media exit) on jam B” on page 2-42. |
| 287.03 Paper jam Check area G1 | Sensor (upper media exit) on jam C | Sensor (upper media exit) is not turned on within the specified time after the sensor (finisher media entrance) is turned on. At this time, the sensor (bridge unit media exit) is turned on. Go to “287.03 Sensor (upper media exit) on jam C” on page 2-44. |
| 287.04 Paper jam Check area G | Sensor (upper media exit) off jam B | Sensor (upper media exit) is not turned off within the specified time after the sensor (upper media exit) is turned on. At this time, the sensor (bridge unit media exit) is turned off. Go to “287.04 Sensor (upper media exit) off jam B.” on page 2-45. |

| | | |
|---|--|--|
| 287.05 Paper jam Check area F | Sensor (upper media exit) Static jam A | Paper remains on the sensor (upper media exit). At this time, the sensor (bridge unit media exit) is turned on. Go to “287.05 Sensor (upper media exit) static jam A” on page 2-46. |
| 287.06 Paper jam Check areas G1, G3 | Sensor (upper media exit) Static jam B | Paper remains on the sensor (upper media exit). At this time, the sensor (bridge unit media exit) is off state but the finisher sensor (finisher media entrance) is turned on. Go to “287.06 Sensor (upper media exit) static jam B” on page 2-47. |
| 287.07 Paper jam Check area G1 | Sensor (upper media exit) Static jam C | Paper remains on the sensor (upper media exit). At this time, both sensor (bridge unit media exit) and sensor (finisher media entrance) are turned off. Go to “287.07 Sensor (upper media exit) static jam C” on page 2-48. |
| 288.00 Paper jam Check area F | Sensor (diverter gate) on jam | Sensor (diverter gate) is not turned on within the specified time after the sensor (bridge unit media exit) is turned on. Go to “288.00 Sensor (diverter gate) on jam” on page 2-49. |
| 288.01 Paper jam Check area F | Sensor (diverter gate) Static jam (to top bin) A | Paper remains on the sensor (diverter gate) when the finisher is in the upper bin exit mode. At this time the sensor (bridge unit media exit) is turned on. Go to “288.01 Sensor (diverter gate) static jam (to top bin) A” on page 2-51. |
| 288.02 Paper jam Check areas G1, G3 | Sensor (diverter gate) Static jam (to top bin) B | Paper remains on the sensor (diverter gate) when the finisher is in the upper bin exit mode. At this time, the sensor (finisher media entrance) is on state, but the sensor (bridge unit media exit) is turned off. Go to “288.02 Sensor (diverter gate) static jam (to top bin) B” on page 2-52. |
| 288.03 Paper jam Check area G1 | Sensor (diverter gate) Static jam (to top bin) C | Paper remains on the sensor (diverter gate) when the finisher is in the upper bin exit mode. At this time, both sensor (finisher media entrance) and sensor (bridge unit media exit) are turned off. Go to “288.03 Sensor (diverter gate) static jam (to top bin) C” on page 2-53. |
| 288.04 Paper jam Check area F | Sensor (diverter gate) Static jam (to stacker bin) A | Paper remains on the sensor (diverter gate) when the finisher is in the stacker bin exit mode. At this time, the sensor (bridge unit media exit) is turned on. Go to “288.04 Sensor (diverter gate) static jam (to stacker bin) A” on page 2-54. |
| 288.05 Paper jam Check areas G2, G3 | Sensor (diverter gate) Static jam (to stacker bin) B | Paper remains on the sensor (diverter gate) when the finisher is in the stacker bin exit mode. At this time, the sensor (finisher media entrance) is on state, but the sensor (bridge unit media exit) is turned off. Go to “288.05 Sensor (diverter gate) static jam (to stacker bin) B” on page 2-55. |

| | | |
|--------------------------------------|---|---|
| 288.06 Paper jam Check area G2 | Sensor (diverter gate) Static jam (to stacker bin) C | Paper remains on the sensor (diverter gate) when the finisher is in the stacker bin exit mode. At this time, both sensor (finisher media entrance) and sensor (bridge unit media exit) are turned off. Go to “288.06 Sensor (diverter gate) static jam (to stacker bin) C” on page 2-56. |
| 980.02 Service finisher comm. | Finisher communication failure | A communication error occurred between the printer engine card assembly and the finisher. Go to “980.02 Finisher communication failure” on page 2-56. |
| 981.00 Service finisher error | Stacker bin failure | The sensor (stacker bin level) is not turned on within the specified period after the stacker bin starts rising. Go to “981.00 Stacker bin failure” on page 2-57. |
| 981.01 Service finisher error | Stacker bin upper limit failure | The stacker bin abnormally rises beyond the specified upper limit position (stacker bin level). Go to “981.01 Stacker bin upper limit failure” on page 2-59. |
| 981.02 Service finisher error | Stacker bin lower limit failure | The stacker bin abnormally lowers beyond the specified lower limit position (full stack). Go to “981.02 Stacker bin lower limit failure” on page 2-60. |
| 982.00 Service finisher error | Sensor (front tamper HP) on failure | The sensor (front tamper HP) is not turned on after the front tamper starts moving to the front tamper home position. Go to “982.00 Sensor (front tamper HP) on failure” on page 2-62. |
| 982.01 Service finisher error | Sensor (front tamper HP) off failure | The sensor (front tamper HP) is not turned off within the specified time after the front tamper starts leaving from the front tamper home position. Or the sensor (front tamper HP) is turned on again after the sensor (front tamper HP) is turned off and the front tamper stopped its moving. Go to “982.01 Sensor (front tamper HP) off failure” on page 2-63. |
| 983.00 Service finisher error | Sensor (rear tamper HP) on failure | The sensor (rear tamper HP) is not turned on after the rear tamper starts moving to the rear tamper home position. Go to “983.00 Sensor (rear tamper HP) on failure” on page 2-64. |
| 983.01 Service finisher error | Sensor (rear tamper HP) off failure | The sensor (rear tamper HP) is not turned off within the specified time after the rear tamper starts leaving from the rear tamper home position. Or the sensor (rear tamper HP) is turned on again after the sensor (rear tamper HP) is turned off and the rear tamper stopped its moving. Go to “983.01 Sensor (rear tamper HP) off failure” on page 2-65. |
| 984.00 Service finisher error | Sensor (punch unit HP) on failure | The sensor (punch unit HP) is not turned on even when the specified time passed after the punch unit motor is turned on. Go to “984.00 Sensor (punch unit HP) on failure” on page 2-66. |

| | | |
|----------------------------------|--|---|
| 984.01 Service finisher error | Sensor (punch unit HP) off failure | The sensor (punch unit HP) is not turned off even when the specified time passed after the punch unit motor is turned on. Go to “984.01 Sensor (punch unit HP) off failure” on page 2-67. |
| 985.00 Service finisher error | Sensor (punch carriage shift HP) on failure | The sensor (punch carriage shift HP) is not turned on even when the specified time passed after the punch carriage shift motor assembly is turned on. Or the sensor (punch carriage shift HP) is turned off again after the sensor (punch carriage shift HP) is turned on and the punch carriage shift motor assembly stopped its rotation. Go to “985.00 Sensor (punch carriage shift HP) on failure” on page 2-68. |
| 985.01 Service finisher error | Sensor (punch carriage shift HP) off failure | The sensor (punch carriage shift HP) is not turned off even when the specified time passed after the punch carriage shift motor assembly is turned on. Or the sensor (punch carriage shift HP) is turned on again after the sensor (punch carriage shift HP) is turned off and the punch carriage shift motor assembly stopped its rotation. Go to “985.01 Sensor (punch carriage shift HP) off failure” on page 2-69. |
| 986.00 Service finisher error | Sensor (media eject clamp HP) on failure | The sensor (eject clamp HP) is not turned on within 500 ms after the eject clamp up starts. Go to “986.00 Sensor (media eject clamp HP) on failure” on page 2-70. |
| 986.01 Service finisher error | Sensor (media eject clamp HP) off failure | The sensor (eject clamp HP) is not turned off within 200 ms after the eject clamp down starts. Go to “986.01 Sensor (media eject clamp HP) off failure” on page 2-71. |
| 987.00 Service finisher error | Sensor (media eject shaft HP) on failure | The sensor (media eject shaft HP) is not turned on within 200 ms after the set clamp starts operating. Go to “987.00 Sensor (media eject shaft HP) on failure” on page 2-72. |
| 987.01 Service finisher error | Sensor (media eject shaft HP) off failure | The sensor (media eject shaft HP) is not turned off within the specified time after the set clamp ends operating. Go to “987.01 Sensor (media eject shaft HP) off failure” on page 2-74. |
| 988.00 Service finisher error | Sensor (punch unit side reg1) on failure Sensor (punch unit side reg2) on failure | The sensor (punch unit side reg1) or sensor (punch unit side reg2) did not detect the media correctly or is defective. Go to “988.00 Sensor (punch unit side reg) on failure” on page 2-75. |
| 988.01 Service finisher error | Sensor (punch unit side reg1) off failure Sensor (punch unit side reg2) off failure | The sensor (punch unit side reg1) or sensor (punch unit side reg2) did not detect the media correctly or is defective. Go to “988.01 Sensor (punch unit side reg) off failure” on page 2-76. |

| | | |
|----------------------------------|--|---|
| 989.00 Service finisher error | Stapler unit failure | The off/on status of the sensor (stapler unit motor HP) is not detected within the specified time after the stapler unit motor (forward operation). Or the sensor (stapler unit motor HP) is not turned on within the specified timer after the stapler unit motor is on (reverse operation). Go to “989.00 Stapler unit failure” on page 2-78. |
| 990.00 Service finisher error | Sensor (stapler carriage HP) on failure | The sensor (stapler carriage HP) is not turned on within two seconds after the stapler starts moving toward the staple position and also the sensor (stapler carriage HP) is off. Or the sensor (stapler carriage HP) is not turned on after the stapler was moved to the staple position. Or the sensor (stapler carriage HP) is turned off again after the sensor (stapler carriage HP) is turned on and the stapler stopped its moving. Go to “990.00 Sensor (stapler carriage HP) on failure” on page 2-78. |
| 990.01 Service finisher error | Sensor (stapler carriage HP) off failure | The sensor (stapler carriage HP) is not turned off within 500 ms after stapler starts moving to the staple position and sensor (stapler carriage HP) is off. Or the sensor (stapler carriage HP) is not turned off after the stapler was moved to the staple position. Or the sensor (stapler carriage HP) is turned on again after the sensor (stapler carriage HP) is turned off and the stapler stopped its moving. Go to “990.01 Sensor (stapler carriage HP) off failure” on page 2-79. |
| 995.00 Service finisher NV | Finisher NVM R/W failure | A read/write error occurred on the NVM of the finisher controller card assembly. Go to “995.00 Finisher NVRAM R/W failure” on page 2-80. |
| 996.00 Service wrong finisher | Finisher type failure | An incorrect type of finisher is connected. Go to “996.00 Finisher type failure” on page 2-80. |
| 999.00 Service finisher error | Finisher engine/RIP functional failure | The engine reported a finisher failure that the RIP card assembly did not recognize. Go to “999.00 Finisher engine/RIP functional failure” on page 2-81. |
| Close cover F | Bridge unit cover is open | Finisher bridge unit cover is open. Go to “999.00 Finisher engine/RIP functional failure” on page 2-81. |
| Close door G | Finisher front door open | The finisher front cover is open. Go to “Finisher front door open” on page 2-82. |
| Close surface H | Eject cover is open | The finisher eject cover is open. Go to “Finisher eject cover open” on page 2-83. |
| Empty hole punch box | Punch waste box full | The punch waste box is filled. Go to “Punch waste box full” on page 2-86. |
| Insert hole punch box | Punch waste box missing | No punch waste box. Go to “No punch waste box.” on page 2-85. |
| Load staples | Staple cartridge empty | Go to “Staple cartridge empty” on page 2-92. |

| | | |
|-------------------------|-----------------------------------|--|
| Remove paper from Bin 1 | Finisher upper media bin full | The upper media bin has reached maximum capacity. Go to “Finisher upper media bin full” on page 2-84. |
| Remove paper from bin 2 | Stacker set over count | When the stapled media exceeds the specified value be able to stack on the stacker bin. Go to “Stacker set over count failure” on page 2-92. |
| Remove paper from Bin 2 | Stacker media bin full (no mix) | The stacker media bin has reached maximum capacity (same media size). Go to “Stacker media bin full (no mix)” on page 2-88. |
| Remove paper from Bin 2 | Stacker media bin full (mix size) | The stacker media bin has reached maximum capacity (mixed media size). Go to “Stacker media bin full (mix size)” on page 2-86. |

Service checks

280.00 Sensor (bridge unit media entrance) on Jam

| Step | Check | Yes | No |
|------|--|---|---|
| 1 | <p>Check the media path.</p> <p>Open the bridge unit top cover assembly of the bridge unit assembly.</p> <p>Check the two transport belts and the six bridge unit pinch rolls attached on the bridge unit top cover assembly by turning them with your fingers.</p> <p>Are the transport belts and the bridge unit pinch rolls installed correctly?</p> | Go to step 2. | Clean or replace the transport belts and bridge unit pinch rolls, and clean the media path. |
| 2 | <p>Are two transport belts and the six bridge unit pinch rolls free of damage?</p> | Go to step 3. | Clean or replace the transport belts and bridge unit pinch roll, and clean the media path. |
| 3 | <p>Check the sensor (bridge unit media entrance) for correct operation.</p> <p>Perform the Bridge media ent test.</p> <ol style="list-style-type: none"> 1. Enter Diagnostics mode. 2. Select FINISHER TESTS. 3. Select Sensor Tests. 4. Select Media Path1. 5. Select Bridge media ent. <p>Does the display on the operator panel change every time the actuator of the sensor (bridge unit media entrance) is operated?</p> | Go to step 5. | Go to step 4. |
| 4 | <p>Check the sensor (bridge unit media entrance) connection.</p> <p>Is the above sensor connected properly?</p> | Replace the sensor (bridge unit media entrance). See "Sensor (bridge unit media entrance) removal" on page 4-16. | Replace the connection. |
| 5 | <p>Check the bridge unit drive motor for correct operation by opening the finisher front door assembly then closing it.</p> <p>Does the bridge unit drive motor rotate normally?</p> | Go to step 7. | Go to step 6. |
| 6 | <p>Check the bridge unit drive motor connection.</p> <p>Is the above motor properly connected?</p> | Replace the bridge unit drive motor. "Bridge unit drive motor assembly removal" on page 4-13. | Replace the connection. |

| Step | Check | Yes | No |
|------|--|---|-----------------|
| 7 | Perform a test print. Does the error still occur? | Replace the bridge unit interface card assembly. See “Bridge unit interface card assembly removal” on page 4-117. Go to step 8. | Problem solved. |
| 8 | Perform a test print. Does the error still occur? | Replace the finisher controller card assembly. See “Finisher controller card assembly removal” on page 4-118. | Problem solved. |

280.01 Sensor (bridge unit media entrance) static jam A

| Step | Check | Yes | No |
|------|--|---|-------------------------|
| 1 | Check the sensor (bridge unit media entrance) for correct operation. Perform the Bridge media ent test. 1. Enter Diagnostics mode. 2. Select FINISHER TESTS. 3. Select Sensor Tests. 4. Select Media Path1. 5. Select Bridge media ent. Does the display on the operator panel change every time the actuator of the sensor (bridge unit media entrance) is operated? | Go to step 3. | Go to step 2. |
| 2 | Check the sensor (bridge unit media entrance) connection Is the above sensor connected properly? | Replace the sensor (bridge unit media entrance). See “Sensor (bridge unit media entrance) removal” on page 4-16. | Replace the connection. |
| 3 | Check the bridge unit drive motor for correct operation. Check the above motor by opening the finisher front door assembly and then closing it. Does the bridge unit drive motor rotate normally? | Go to step 5. | Go to step 4. |
| 4 | Check the bridge unit drive motor connection. Is the above motor connected properly? | Replace the bridge unit drive motor. See “Bridge unit drive motor assembly removal” on page 4-13. | Replace the connection. |

| Step | Check | Yes | No |
|------|--|--|-----------------|
| 5 | Perform a test print. Does the error still occur? | Replace the bridge unit interface card assembly. See “Bridge unit interface card assembly removal” on page 4-117. | Problem solved. |
| 6 | Perform a test print. Does the error still occur? | Replace the finisher controller card assembly. See “Finisher controller card assembly removal” on page 4-118. | Problem solved. |

280.02 Sensor (bridge unit media entrance) static jam B

| Step | Check | Yes | No |
|------|--|---|-------------------------|
| 1 | Check the sensor (bridge unit media entrance) for correct operation. Perform the Bridge media ent test. 1. Enter Diagnostics mode. 2. Select FINISHER TESTS. 3. Select Sensor Tests. 4. Select Media Path1. 5. Select Bridge media ent. Does the display on the operator panel change every time the actuator of the sensor (bridge unit media entrance) is operated? | Go to step 3. | Go to step 2. |
| 2 | Check the sensor (bridge unit media entrance) connection Is the above sensor connected properly? | Replace the sensor (bridge unit media entrance). See “Sensor (bridge unit media entrance) removal” on page 4-16. | Replace the connection. |
| 3 | Check the bridge unit drive motor for correct operation. Check the above motor by opening the finisher front door assembly and then closing it. Does the bridge unit drive motor rotate normally? | Go to step 5. | Go to step 4. |
| 4 | Check the bridge unit drive motor connection. Is the above motor connected properly? | Replace the bridge unit drive motor. See “Bridge unit drive motor assembly removal” on page 4-13. | Replace the connection. |

| Step | Check | Yes | No |
|------|--|--|-----------------|
| 5 | Perform a test print. Does the error still occur? | Replace the bridge unit interface card assembly. See “Bridge unit interface card assembly removal” on page 4-117. | Problem solved. |
| 6 | Perform a test print. Does the error still occur? | Replace the finisher controller card assembly. See “Finisher controller card assembly removal” on page 4-118. | Problem solved. |

281.00 Sensor (bridge unit media exit) On Jam A

| Step | Check | Yes | No |
|------|--|---|---|
| 1 | Check the media path. 1. Open the bridge unit top cover assembly of the bridge unit assembly. 2. Check the transport belts and the six bridge unit pinch rolls attached on the bridge unit top cover assembly by turning them with your fingers. Are the transport belts and the bridge unit pinch rolls installed correctly? | Go to step 2. | Clean or replace the transport belts and bridge unit pinch rolls, and clean the media path. |
| 2 | Are two transport belts and the six bridge unit pinch roll free of damage? | Go to step 3. | Clean or replace the transport belts and bridge unit pinch roll, and clean the media path. |
| 3 | Check the sensor (bridge unit media exit) for correct operation. Perform the Bridge media exit test. 1. Enter Diagnostics mode. 2. Select FINISHER TESTS. 3. Select Sensor Tests. 4. Select Media Path1. 5. Select Bridge media exit. Does the display on the operator panel change every time the actuator of the sensor (bridge unit media exit) is operated? | Go to step 5. | Go to step 4. |
| 4 | Check the sensor (bridge unit media exit) connection. Is the above sensor connected properly? | Replace the sensor (bridge unit media exit). See “Sensor (bridge unit media exit) removal” on page 4-17. | Replace the connection. |

| Step | Check | Yes | No |
|------|---|---|-------------------------|
| 5 | Check the bridge unit drive motor by opening the finisher front door assembly and then closing it. Does the bridge unit drive motor rotate normally? | Go to step 7. | Go to step 6. |
| 6 | Check the bridge unit drive motor connection. Is the above motor properly connected? | Replace the bridge unit drive motor. See “Bridge unit drive motor assembly removal” on page 4-13. | Replace the connection. |
| 7 | Perform a test print. Does the error still occur? | Replace the bridge unit interface card assembly. See “Bridge unit interface card assembly removal” on page 4-117. Go to step 8. | Problem solved. |
| 8 | Perform a test print. Does the error still occur? | Replace the finisher controller card assembly. See “Finisher controller card assembly removal” on page 4-118. | Problem solved. |

281.01 Sensor (bridge unit media exit) On Jam B

| Step | Check | Yes | No |
|------|--|---------------|---|
| 1 | Check the media path. 1. Open the bridge unit top cover assembly of the bridge unit assembly. 2. Check the transport belts and the six bridge unit pinch rolls attached on the bridge unit top cover assembly by turning them with your fingers. Are the transport belts and the bridge unit pinch rolls installed correctly? | Go to step 2. | Clean or replace the transport belts and bridge unit pinch rolls, and clean the media path. |
| 2 | Are two transport belts and the six bridge unit pinch roll free of damage? | Go to step 3. | Clean or replace the transport belts and bridge unit pinch roll, and clean the media path. |

| Step | Check | Yes | No |
|------|--|--|-------------------------|
| 3 | <p>Check the sensor (bridge unit media exit) for correct operation.</p> <p>Perform the Bridge media exit test.</p> <ol style="list-style-type: none"> 1. Enter Diagnostics mode. 2. Select FINISHER TESTS. 3. Select Sensor Tests. 4. Select Media Path1. 5. Select Bridge media exit. <p>Does the display on the operator panel change every time the actuator of the sensor (bridge unit media exit) is operated?</p> | Go to step 5. | Go to step 4. |
| 4 | <p>Check the sensor (bridge unit media exit) connection.</p> <p>Is the above sensor connected properly?</p> | <p>Replace the sensor (bridge unit media exit). See “Sensor (bridge unit media exit) removal” on page 4-17.</p> | Replace the connection. |
| 5 | <p>Check the bridge unit drive motor by opening the finisher front door assembly and then closing it.</p> <p>Does the bridge unit drive motor rotate normally?</p> | Go to step 7. | Go to step 6. |
| 6 | <p>Check the bridge unit drive motor connection.</p> <p>Is the above motor properly connected?</p> | <p>Replace the bridge unit drive motor. See “Bridge unit drive motor assembly removal” on page 4-13.</p> | Replace the connection. |
| 7 | <p>Perform a test print.</p> <p>Does the error still occur?</p> | <p>Replace the bridge unit interface card assembly. See “Bridge unit interface card assembly removal” on page 4-117.</p> <p>Go to step 8.</p> | Problem solved. |
| 8 | <p>Perform a test print.</p> <p>Does the error still occur?</p> | <p>Replace the finisher controller card assembly. See “Finisher controller card assembly removal” on page 4-118.</p> | Problem solved. |

281.02 Sensor (bridge unit media exit) On Jam C

| Step | Check | Yes | No |
|------|--|--|---|
| 1 | <p>Check the media path.</p> <ol style="list-style-type: none"> 1. Open the bridge unit top cover assembly of the bridge unit assembly. 2. Check the transport belts and the six bridge unit pinch rolls attached on the bridge unit top cover assembly by turning them with your fingers. <p>Are the transport belts and the bridge unit pinch rolls installed correctly?</p> | Go to step 2. | Clean or replace the transport belts and bridge unit pinch rolls, and clean the media path. |
| 2 | <p>Are two transport belts and the six bridge unit pinch roll free of damage?</p> | Go to step 3. | Clean or replace the transport belts and bridge unit pinch roll, and clean the media path. |
| 3 | <p>Check the sensor (bridge unit media exit) for correct operation.</p> <p>Perform the Bridge media exit test.</p> <ol style="list-style-type: none"> 1. Enter Diagnostics mode. 2. Select FINISHER TESTS. 3. Select Sensor Tests. 4. Select Media Path1. 5. Select Bridge media exit. <p>Does the display on the operator panel change every time the actuator of the sensor (bridge unit media exit) is operated?</p> | Go to step 5. | Go to step 4. |
| 4 | <p>Check the sensor (bridge unit media exit) connection.</p> <p>Is the above sensor connected properly?</p> | <p>Replace the sensor (bridge unit media exit). See “Sensor (bridge unit media exit) removal” on page 4-17.</p> | Replace the connection. |
| 5 | <p>Check the bridge unit drive motor by opening the finisher front door assembly and then closing it.</p> <p>Does the bridge unit drive motor rotate normally?</p> | Go to step 7. | Go to step 6. |
| 6 | <p>Check the bridge unit drive motor connection.</p> <p>Is the above motor properly connected?</p> | <p>Replace the bridge unit drive motor. See “Bridge unit drive motor assembly removal” on page 4-13.</p> | Replace the connection. |
| 7 | <p>Perform a test print.</p> <p>Does the error still occur?</p> | <p>Replace the bridge unit interface card assembly. See “Bridge unit interface card assembly removal” on page 4-117.</p> <p>Go to step 8.</p> | Problem solved. |

| Step | Check | Yes | No |
|------|--|--|-----------------|
| 8 | Perform a test print. Does the error still occur? | Replace the finisher controller card assembly. See “Finisher controller card assembly removal” on page 4-118. | Problem solved. |

281.03 Sensor (bridge unit media exit) static jam A

| Step | Check | Yes | No |
|------|--|--|-------------------------|
| 1 | Check the sensor (bridge unit media exit) for correct operation. Perform the Bridge media exit test. 1. Enter Diagnostics mode. 2. Select FINISHER TESTS. 3. Select Sensor Tests. 4. Select Media Path1. 5. Select Bridge media exit. Does the display on the operator panel change every time the actuator of the sensor (bridge unit media exit) is operated? | Go to step 4. | Go to step 2. |
| 2 | Check the sensor (bridge unit media exit) connection. Is the above sensor connected properly? | Replace the sensor (bridge unit media exit). See “Sensor (bridge unit media exit) removal” on page 4-17. | Replace the connection. |
| 3 | Check the bridge unit drive motor for correct operation. Check the above motor by opening the finisher front door assembly and then closing it. Does the bridge unit drive motor rotate normally? | Go to step 5. | Go to step 4. |
| 4 | Check the bridge unit drive motor connection. Are the connectors of the bridge unit cable assembly connected to the bridge unit drive motor and bridge unit interface card assembly of the finisher correctly connected? | Replace the bridge unit drive motor. See “Bridge unit drive motor assembly removal” on page 4-13. | Replace the connection. |
| 5 | Perform a test print. Does the error still occur? | Replace the bridge unit interface card assembly. See “Bridge unit interface card assembly removal” on page 4-117. | Problem solved. |

| Step | Check | Yes | No |
|------|--|--|-----------------|
| 6 | Perform a test print. Does the error still occur? | Replace the finisher controller card assembly. See “Finisher controller card assembly removal” on page 4-118. | Problem solved. |

282.00 Sensor (finisher media entrance) on jam

| Step | Check | Yes | No |
|------|--|---|---|
| 1 | Check the media path. 1. Open the bridge unit top cover assembly of the bridge unit assembly. 2. Check two transport belts and the six bridge unit pinch rolls attached on the bridge unit top cover assembly by turning them with your fingers. Are transport belts and the bridge unit pinch rolls installed correctly? | Go to step 2. | Clean or replace the transport belts and bridge unit pinch rolls, and clean the media path. |
| 2 | Are two transport belts and the six bridge unit pinch roll free of damage? | Go to step 3. | Clean or replace the transport belts and bridge unit pinch rolls, and clean the media path. |
| 3 | Check sensor (bridge unit media exit) for correct operation. Perform the Bridge media exit test. 1. Enter Diagnostics mode. 2. Select FINISHER TESTS . 3. Select Sensor Tests . 4. Select Media Path1 . 5. Select Bridge media exit . Does the display on the operator panel change every time the actuator of the sensor (bridge unit media exit) is operated? | Go to step 6. | Go to step 4. |
| 4 | Check the sensor (bridge unit media exit) connection. Is the above sensor connected properly? | Replace the sensor (bridge unit media exit). See “Sensor (bridge unit media exit) removal” on page 4-17. | After reconnecting, go to step 5. |

| Step | Check | Yes | No |
|------|--|---|-------------------------|
| 5 | <p>Check the sensor (finisher media entrance) for correct operation.</p> <p>Perform the Bridge media ent test.</p> <ol style="list-style-type: none"> 1. Enter Diagnostics mode. 2. Select FINISHER TESTS. 3. Select Sensor Tests. 4. Select Media Path1. 5. Select Bridge media ent. <p>Does the display on the operator panel change every time a piece of white media is placed over the sensing area of the sensor (finisher media entrance)?</p> | Go to step 7. | Go to step 6. |
| 9 | <p>Check the sensor (finisher media entrance) connection.</p> <p>Is the above sensor connected properly?</p> | Replace the sensor (finisher media entrance). See “Sensor (bridge unit media entrance) removal” on page 4-16. | Replace the connection. |
| 7 | <p>Check the bridge unit drive motor by opening the finisher front door assembly and then closing it.</p> <p>Does the bridge unit drive motor rotate normally?</p> | Go to step 9. | Go to step 8. |
| 8 | <p>Is the bridge unit drive motor connected properly?</p> | Replace the bridge unit drive motor. See “Bridge unit drive motor assembly removal” on page 4-13. | Replace the connection. |
| 9 | <p>Perform a test print.</p> <p>Does the error still occur?</p> | <p>Replace the bridge unit interface card assembly. See “Bridge unit interface card assembly removal” on page 4-117.</p> <p>Go to step 10.</p> | Problem solved. |
| 10 | <p>Perform a test print.</p> <p>Does the error still occur?</p> | Replace the finisher controller card assembly. See “Finisher controller card assembly removal” on page 4-118. | Problem solved. |

282.01 Sensor (finisher media entrance) static jam A

| Step | Check | Yes | No |
|------|--|---|-------------------------|
| 1 | <p>Check the sensor (finisher media entrance) for correct operation.</p> <p>Perform the Fin media ent test.</p> <ol style="list-style-type: none"> 1. Enter Diagnostics mode 2. Select FINISHER TESTS. 3. Select Sensor Tests. 4. Select Media Path1. 5. Select Fin media ent. <p>Does the display change, every time a piece of white media is placed over the sensor (finisher media entrance)?</p> | Go to step 3. | Go to step 2. |
| 2 | <p>Check the sensor (finisher media entrance) connection,</p> <p>Is the above sensor connected correctly?</p> | Replace the sensor (finisher media entrance). See "Sensor (finisher media entrance) removal" on page 4-98. | Replace the connector. |
| 3 | <p>Check the drive motor (entrance/paddle) for correct operation.</p> <p>Check the above motor by opening the finisher front door assembly and then closing it.</p> <p>Does the motor (entrance/paddle) rotate normally?</p> | Go to step 5. | Go to step 4. |
| 4 | <p>Check the drive motor (entrance/paddle) connection.</p> <p>Are the connections of the main drive cable assembly correctly connected?</p> | Replace the drive motor (entrance/paddle). See "Drive motor (entrance/paddle) and belt (entrance/paddle) removal" on page 4-100. | Replace the connection. |
| 5 | <p>Perform a test print.</p> <p>Does the error still occur?</p> | Replace the finisher controller card assembly. See "Finisher controller card assembly removal" on page 4-118. | Problem solved. |

283.00 Sensor (buffer path) on jam A

| Step | Check | Yes | No |
|------|--|--|---|
| 1 | <p>Check the media path.</p> <ol style="list-style-type: none"> 1. Open the finisher front door assembly of the finisher. 2. Remove the top cover and left upper cover. 3. Open the entrance pinch guide assembly upward. 4. Check the media entrance roll assembly and the media entrance pinch guide pinch roll attached on the media entrance pinch guide assembly by turning them with your fingers. <p>Are the media entrance roll assembly and the media entrance pinch guide pinch rolls operating correctly?</p> | Go to step 2. | Clean or replace the appropriate rolls and clean the media path. |
| 2 | <p>Are the media entrance roll assembly and the media entrance pinch guide pinch rolls free of damage, and rotate smoothly?</p> | Go to step 3. | Clean or replace the appropriate rolls and clean the paper path. |
| 3 | <p>Check the media path.</p> <ol style="list-style-type: none"> 1. Open the finisher front door assembly of the finisher. 2. Remove the top cover and left upper cover. 3. Open the lower pinch guide assembly to the right. 4. Check the buffer roll assembly by turning it with your fingers. <p>Is the buffer roll assembly installed correctly, and is it free of damage and contamination?</p> | Go to step 4. | Clean or replace the appropriate rolls, and clean the media path. |
| 4 | <p>Are the four buffer pinch guide pinch rolls attached on the lower pinch guide assembly installed correctly?</p> | Go to step 5. | Clean or replace the appropriate rolls and clean the media path. |
| 5 | <p>Check the sensor (diverter gate) for correct operation. Perform the Diverter gate test.</p> <ol style="list-style-type: none"> 1. Enter Diagnostics mode. 2. Select FINISHER TESTS. 3. Select Sensor Tests. 4. Select Media Path2. 5. Select Diverter gate. <p>Does the display on the operator panel change every time a piece of white media is placed over the sensing area of the sensor (diverter gate)?</p> | Go to step 7. | Go to step 6. |
| 6 | <p>Check the sensor (diverter gate) connection. Is the above sensor connected properly?</p> | Replace the sensor (diverter gate). See "Sensor (diverter gate) removal" on page 4-110. | After reconnecting, go to step 7. |

| Step | Check | Yes | No |
|------|--|---|-----------------------------------|
| 7 | Check the sensor (buffer path) for correct operation. Perform the Buffer path test. 1. Enter Diagnostics mode. 2. Select FINISHER TESTS . 3. Select Sensor Tests . 4. Select Media Path1 . 5. Select Buffer path . Does the display on the operator panel change every time the actuator of the sensor (buffer path) is operated? | Go to step 9. | Go to step 8. |
| 8 | Check the sensor (buffer path) connection. Is the above sensor connect properly? | Replace the sensor (buffer path). See “Sensor (buffer path) removal” on page 4-93 . | After reconnecting, go to step 9. |
| 9 | Check the drive motor (buffer/transport) by opening the finisher front door assembly and then closing it. Does the drive motor (buffer/transport) rotate normally? | Go to step 11. | Go to step 10. |
| 10 | Check the drive motor (buffer/transport) connection. Is the above motor connected properly? | Replace the drive motor (buffer/transport). See “Drive motor (buffer/transport) and belt (buffer/transport) removal” on page 4-115 . | Problem solved. |
| 11 | Perform a test print. Does the error still occur? | Replace the bridge unit interface card assembly. See “Bridge unit interface card assembly removal” on page 4-117 . Go to step 12. | Problem solved. |
| 12 | Perform a test print. Does the error still occur? | Replace the finisher controller card assembly. See “Finisher controller card assembly removal” on page 4-118 . | Problem solved. |

283.01 Sensor (buffer path) on jam B

| Step | Check | Yes | No |
|------|--|--|---|
| 1 | <p>Check the media path.</p> <ol style="list-style-type: none"> 1. Open the finisher front door assembly of the finisher. 2. Remove the top cover and left upper cover. 3. Open the entrance pinch guide assembly upward. 4. Check the media entrance roll assembly and the media entrance pinch guide pinch roll attached on the media entrance pinch guide assembly by turning them with your fingers. <p>Are the media entrance roll assembly and the media entrance pinch guide pinch rolls operating correctly?</p> | Go to step 2. | Clean or replace the appropriate rolls and clean the media path. |
| 2 | <p>Are the media entrance roll assembly and the media entrance pinch guide pinch rolls free of damage, and rotate smoothly?</p> | Go to step 3. | Clean or replace the appropriate rolls and clean the paper path. |
| 3 | <p>Check the media path.</p> <ol style="list-style-type: none"> 1. Open the finisher front door assembly of the finisher. 2. Remove the top cover and left upper cover. 3. Open the lower pinch guide assembly to the right. 4. Check the buffer roll assembly by turning it with your fingers. <p>Is the buffer roll assembly installed correctly, and is it free of damage and contamination?</p> | Go to step 4. | Clean or replace the appropriate rolls, and clean the media path. |
| 4 | <p>Are the four buffer pinch guide pinch rolls attached on the lower pinch guide assembly installed correctly?</p> | Go to step 5. | Clean or replace the appropriate rolls and clean the media path. |
| 5 | <p>Check the sensor (diverter gate) for correct operation. Perform the Diverter gate test.</p> <ol style="list-style-type: none"> 1. Enter Diagnostics mode. 2. Select FINISHER TESTS. 3. Select Sensor Tests. 4. Select Media Path2. 5. Select Diverter gate. <p>Does the display on the operator panel change every time a piece of white media is placed over the sensing area of the sensor (diverter gate)?</p> | Go to step 7. | Go to step 6. |
| 6 | <p>Check the sensor (diverter gate) connection. Is the above sensor connected properly?</p> | Replace the sensor (diverter gate). See "Sensor (diverter gate) removal" on page 4-110. | After reconnecting, go to step 7. |

| Step | Check | Yes | No |
|------|--|---|-----------------------------------|
| 7 | <p>Check the sensor (buffer path) for correct operation.</p> <p>Perform the Buffer path test.</p> <ol style="list-style-type: none"> 1. Enter Diagnostics mode. 2. Select FINISHER TESTS. 3. Select Sensor Tests. 4. Select Media Path1. 5. Select Buffer path. <p>Does the display on the operator panel change every time the actuator of the sensor (buffer path) is operated?</p> | Go to step 9. | Go to step 8. |
| 8 | <p>Check the sensor (buffer path) connection.</p> <p>Is the above sensor connect properly?</p> | Replace the sensor (buffer path). See “Sensor (buffer path) removal” on page 4-93. | After reconnecting, go to step 9. |
| 9 | <p>Check the drive motor (buffer/transport) by opening the finisher front door assembly and then closing it.</p> <p>Does the drive motor (buffer/transport) rotate normally?</p> | Go to step 11. | Go to step 10. |
| 10 | <p>Check the drive motor (buffer/transport) connection.</p> <p>Is the above motor connected properly?</p> | Replace the drive motor (buffer/transport). See “Drive motor (buffer/transport) and belt (buffer/transport) removal” on page 4-115. | Problem solved. |
| 11 | <p>Perform a test print.</p> <p>Does the error still occur?</p> | <p>Replace the bridge unit interface card assembly. See “Bridge unit interface card assembly removal” on page 4-117.</p> <p>Go to step 12.</p> | Problem solved. |
| 12 | <p>Perform a test print.</p> <p>Does the error still occur?</p> | Replace the finisher controller card assembly. See “Finisher controller card assembly removal” on page 4-118. | Problem solved. |

283.02 Sensor (buffer path) static jam A

| Step | Check | Yes | No |
|------|--|--|-------------------------|
| 1 | <p>Check the sensor (buffer path) for correct operation.</p> <p>Perform the Buffer path test.</p> <ol style="list-style-type: none"> 1. Enter Diagnostics mode. 2. Select FINISHER TESTS. 3. Select Sensor Tests. 4. Select Media Path1. 5. Select Buffer path. <p>Does the display on the operator panel change every time the actuator of the sensor (buffer path) is operated?</p> | Go to step 3. | Go to step 2. |
| 2 | <p>Check the sensor (buffer path) connection.</p> <p>Is the above sensor connected properly?</p> | Replace the sensor (buffer path). See “Sensor (buffer path) removal” on page 4-93. | Replace the connection. |
| 3 | <p>Check the drive motor (buffer/transport) for correct operation.</p> <p>Check the above motor by opening the finisher front door assembly and then closing it.</p> <p>Does the drive motor (buffer/transport) rotate normally?</p> | Go to step 5. | Go to step 4. |
| 4 | <p>Check the drive motor (buffer/transport) connection.</p> <p>Is the above motor connect properly?</p> | Replace the drive motor (buffer/transport). See “Drive motor (buffer/transport) and belt (buffer/transport) removal” on page 4-115. | Replace the connection. |
| 5 | <p>Perform a test print.</p> <p>Does the error still occur?</p> | Replace the finisher controller card assembly. See “Finisher controller card assembly removal” on page 4-118. | Problem solved. |

283.03 Sensor (buffer path) static jam B

| Step | Check | Yes | No |
|------|--|--|-------------------------|
| 1 | <p>Check the sensor (buffer path) for correct operation.</p> <p>Perform the Buffer path test.</p> <ol style="list-style-type: none"> 1. Enter Diagnostics mode. 2. Select FINISHER TESTS. 3. Select Sensor Tests. 4. Select Media Path1. 5. Select Buffer path. <p>Does the display on the operator panel change every time the actuator of the sensor (buffer path) is operated?</p> | Go to step 3. | Go to step 2. |
| 2 | <p>Check the sensor (buffer path) connection.</p> <p>Is the above sensor connected properly?</p> | Replace the sensor (buffer path). See “Sensor (buffer path) removal” on page 4-93. | Replace the connection. |
| 3 | <p>Check the drive motor (buffer/transport) for correct operation.</p> <p>Check the above motor by opening the finisher front door assembly and then closing it.</p> <p>Does the drive motor (buffer/transport) rotate normally?</p> | Go to step 5. | Go to step 4. |
| 4 | <p>Check the drive motor (buffer/transport) connection.</p> <p>Is the above motor connect properly?</p> | Replace the drive motor (buffer/transport). See “Drive motor (buffer/transport) and belt (buffer/transport) removal” on page 4-115. | Replace the connection. |
| 5 | <p>Perform a test print.</p> <p>Does the error still occur?</p> | Replace the finisher controller card assembly. See “Finisher controller card assembly removal” on page 4-118. | Problem solved. |

283.04 Sensor (buffer path) static jam C

| Step | Check | Yes | No |
|------|--|--|-------------------------|
| 1 | <p>Check the sensor (buffer path) for correct operation.</p> <p>Perform the Buffer path test.</p> <ol style="list-style-type: none"> 1. Enter Diagnostics mode. 2. Select FINISHER TESTS. 3. Select Sensor Tests. 4. Select Media Path1. 5. Select Buffer path. <p>Does the display on the operator panel change every time the actuator of the sensor (buffer path) is operated?</p> | Go to step 3. | Go to step 2. |
| 2 | <p>Check the sensor (buffer path) connection.</p> <p>Is the above sensor connected properly?</p> | Replace the sensor (buffer path). See "Sensor (buffer path) removal" on page 4-93. | Replace the connection. |
| 3 | <p>Check the drive motor (buffer/transport) for correct operation.</p> <p>Check the above motor by opening the finisher front door assembly and then closing it.</p> <p>Does the drive motor (buffer/transport) rotate normally?</p> | Go to step 5. | Go to step 4. |
| 4 | <p>Check the drive motor (buffer/transport) connection.</p> <p>Is the above motor connect properly?</p> | Replace the drive motor (buffer/transport). See "Drive motor (buffer/transport) and belt (buffer/transport) removal" on page 4-115. | Replace the connection. |
| 5 | <p>Perform a test print.</p> <p>Does the error still occur?</p> | Replace the finisher controller card assembly. See "Finisher controller card assembly removal" on page 4-118. | Problem solved. |

284.00 Sensor (lower media exit) off jam A.

| Step | Check | Yes | No |
|------|--|---------------|--|
| 1 | <p>Check the media path.</p> <p>Open the finisher front door assembly of the finisher. Check lower media exit roll assembly by turning it with your fingers.</p> <p>Is the lower media exit roll assembly installed correctly?</p> | Go to step 2. | Clean or replace the lower media exit roll assembly, and clean the media path. |

| Step | Check | Yes | No |
|------|---|---|--|
| 2 | Is the lower media exit roll assembly free of damage? | Go to step 3. | Clean or replace the lower media exit roll assembly, and clean the media path. |
| 3 | Check the sensor (lower media exit) for correct operation. Perform the Lower media exit test. 1. In Diagnostics mode. 2. Select FINISHER TESTS . 3. Select Sensor Tests . 4. Select Media Path1 . 5. Select Lower media exit . Does the display on the operator panel change every time the actuator of the sensor (lower media exit) is operated? | Go to step 5. | Go to step 4. |
| 4 | Check the sensor (lower media exit) connection. Is the above sensor connected properly? | Replace the sensor (lower media exit). See “Sensor (lower media exit) removal” on page 4-80 . | Replace the connection. |
| 5 | Check the drive motor (exit) by opening the finisher front door assembly and then closing it. Does the motor (exit) rotate normally? | Go to step 7. | Go to step 6. |
| 6 | Check the drive motor (exit) connection. Is the above motor connected properly? | Replace the drive motor (exit). See “Drive motor (exit) assembly and belt (exit) removal” on page 4-113 | Replace the connection. |
| 7 | Perform a test print. Does the error still occur? | Replace the finisher controller card assembly. See “Finisher controller card assembly removal” on page 4-118 . | Problem solved. |

284.01 Sensor (lower media exit) on jam A

| Step | Check | Yes | No |
|------|--|--|--|
| 1 | <p>Check the media path.</p> <ol style="list-style-type: none"> 1. Open the finisher front door assembly of the finisher. 2. Open the lower pinch guide assembly to the right. 3. Open the buffer pinch guide assembly downward. 4. Check the buffer roll assembly by turning the rolls with your fingers. <p>Is the buffer roll assembly installed correctly?</p> | Go to step 2. | Clean or replace the appropriate roll, and clean the media path. |
| 2 | Is the buffer roll assembly free of damage? | Go to step 3. | Clean or replace the appropriate roll, and clean the media path. |
| 3 | Are the buffer pinch guide pinch rolls attached to the buffer pinch guide assembly correctly? | Go to step 4. | Clean or replace the appropriate roller, and clean the media path. |
| 4 | Are the buffer pinch guide pinch rolls free of damage? | Go to step 5. | Clean or replace the appropriate roller, and clean the media path. |
| 5 | <p>Check the sensor (buffer path) for correct operation.</p> <p>Perform the Buffer path test.</p> <ol style="list-style-type: none"> 1. Enter Diagnostics mode. 2. Select FINISHER TESTS. 3. Select Sensor Tests. 4. Select Media Path1. 5. Select Buffer path. <p>Does the display on the operator panel change every time the actuator of the sensor (buffer path) is operated?</p> | Go to step 7. | Go to step 6. |
| 6 | <p>Check the sensor (buffer path) connection.</p> <p>Is the above sensor connected properly?</p> | Replace the sensor (buffer path). See "Sensor (buffer path) removal" on page 4-93. | Replace the connection. |
| 7 | <p>Check the drive motor (buffer/transport) by opening the finisher front door assembly and then closing it.</p> <p>Does the drive motor (buffer/transport) rotate normally?</p> | Go to step 9. | Go to step 8. |
| 8 | <p>Check the drive motor (buffer/transport) connection.</p> <p>Is the above motor connected properly?</p> | Replace the drive motor (buffer/transport). See "Drive motor (buffer/transport) and belt (buffer/transport) removal" on page 4-115. | Replace the connection. |

| Step | Check | Yes | No |
|------|--|--|-------------------------|
| 9 | Check the sensor (diverter gate) for correct operation. Perform the Diverter gate test. 1. Enter Diagnostics mode. 2. Select FINISHER TESTS . 3. Select Sensor Tests . 4. Select Media Path2 . 5. Select Diverter gate . Does the operator panel display change each time a piece of media is placed at the front of the sensor (diverter gate)? | Go to step 11. | Go to step 10. |
| 10 | Check the sensor (diverter gate) for connection. Is the above sensor connected properly? | Replace the sensor (diverter gate). See “Sensor (diverter gate) removal” on page 4-110. | Replace the connection. |
| 11 | Check the sensor (lower media exit) for correct operation. Perform the Lower media exit test. 1. Enter Diagnostics mode. 2. Select FINISHER TESTS . 3. Select Sensor Tests . 4. Select Media Path1 . 5. Select Lower media exit . Does the display on the operator panel change every time the actuator of the sensor (lower media exit) is operated? | Go to step 13. | Go to step 12. |
| 12 | Check the sensor (lower media exit) connection. Is the above sensor connected properly? | Replace the sensor (lower media exit). See “Sensor (lower media exit) removal” on page 4-80. | Replace the connection. |
| 13 | Perform a test print. Does the error still occur? | Replace the finisher controller card assembly. See “Finisher controller card assembly removal” on page 4-118. | Problem solved. |

284.02 Sensor (lower media exit) on jam B

| Step | Check | Yes | No |
|------|--|--|--|
| 1 | <p>Check the media path.</p> <ol style="list-style-type: none"> 1. Open the finisher front door assembly of the finisher. 2. Open the lower pinch guide assembly to the right. 3. Open the buffer pinch guide assembly downward. 4. Check the buffer roll assembly by turning the rolls with your fingers. <p>Is the buffer roll assembly installed correctly?</p> | Go to step 2. | Clean or replace the appropriate roll, and clean the media path. |
| 2 | Is the buffer roll assembly free of damage? | Go to step 3. | Clean or replace the appropriate roll, and clean the media path. |
| 3 | Are the buffer pinch guide pinch rolls attached to the buffer pinch guide assembly correctly? | Go to step 4. | Clean or replace the appropriate roller, and clean the media path. |
| 4 | Are the buffer pinch guide pinch rolls free of damage? | Go to step 5. | Clean or replace the appropriate roller, and clean the media path. |
| 5 | <p>Check the sensor (buffer path) for correct operation.</p> <p>Perform the Buffer path test.</p> <ol style="list-style-type: none"> 1. Enter Diagnostics mode. 2. Select FINISHER TESTS. 3. Select Sensor Tests. 4. Select Media Path1. 5. Select Buffer path. <p>Does the display on the operator panel change every time the actuator of the sensor (buffer path) is operated?</p> | Go to step 7. | Go to step 6. |
| 6 | <p>Check the sensor (buffer path) connection.</p> <p>Is the above sensor connected properly?</p> | Replace the sensor (buffer path). See "Sensor (buffer path) removal" on page 4-93. | Replace the connection. |
| 7 | <p>Check the drive motor (buffer/transport) by opening the finisher front door assembly and then closing it.</p> <p>Does the drive motor (buffer/transport) rotate normally?</p> | Go to step 9. | Go to step 8. |
| 8 | <p>Check the drive motor (buffer/transport) connection.</p> <p>Is the above motor connected properly?</p> | Replace the drive motor (buffer/transport). See "Drive motor (buffer/transport) and belt (buffer/transport) removal" on page 4-115. | Replace the connection. |

| Step | Check | Yes | No |
|------|--|--|-------------------------|
| 9 | Check the sensor (diverter gate) for correct operation. Perform the Diverter gate test. 1. Enter Diagnostics mode. 2. Select FINISHER TESTS . 3. Select Sensor Tests . 4. Select Media Path2 . 5. Select Diverter gate . Does the operator panel display change each time a piece of media is placed at the front of the sensor (diverter gate)? | Go to step 11. | Go to step 10. |
| 10 | Check the sensor (diverter gate) for connection. Is the above sensor connected properly? | Replace the sensor (diverter gate). See “Sensor (diverter gate) removal” on page 4-110. | Replace the connection. |
| 11 | Check the sensor (lower media exit) for correct operation. Perform the Lower media exit test. 1. Enter Diagnostics mode. 2. Select FINISHER TESTS . 3. Select Sensor Tests . 4. Select Media Path1 . 5. Select Lower media exit . Does the display on the operator panel change every time the actuator of the sensor (lower media exit) is operated? | Go to step 13. | Go to step 12. |
| 12 | Check the sensor (lower media exit) connection. Is the above sensor connected properly? | Replace the sensor (lower media exit). See “Sensor (lower media exit) removal” on page 4-80. | Replace the connection. |
| 13 | Perform a test print. Does the error still occur? | Replace the finisher controller card assembly. See “Finisher controller card assembly removal” on page 4-118. | Problem solved. |

284.03 Sensor (lower media exit) on jam C

| Step | Check | Yes | No |
|------|--|--|--|
| 1 | <p>Check the media path.</p> <ol style="list-style-type: none"> 1. Open the finisher front door assembly of the finisher. 2. Open the lower pinch guide assembly to the right. 3. Open the buffer pinch guide assembly downward. 4. Check the buffer roll assembly by turning the rolls with your fingers. <p>Is the buffer roll assembly installed correctly?</p> | Go to step 2. | Clean or replace the appropriate roll, and clean the media path. |
| 2 | Is the buffer roll assembly free of damage? | Go to step 3. | Clean or replace the appropriate roll, and clean the media path. |
| 3 | Are the buffer pinch guide pinch rolls attached to the buffer pinch guide assembly correctly? | Go to step 4. | Clean or replace the appropriate roller, and clean the media path. |
| 4 | Are the buffer pinch guide pinch rolls free of damage? | Go to step 5. | Clean or replace the appropriate roller, and clean the media path. |
| 5 | <p>Check the sensor (buffer path) for correct operation.</p> <p>Perform the Buffer path test.</p> <ol style="list-style-type: none"> 1. Enter Diagnostics mode. 2. Select FINISHER TESTS. 3. Select Sensor Tests. 4. Select Media Path1. 5. Select Buffer path. <p>Does the display on the operator panel change every time the actuator of the sensor (buffer path) is operated?</p> | Go to step 7. | Go to step 6. |
| 6 | <p>Check the sensor (buffer path) connection.</p> <p>Is the above sensor connected properly?</p> | Replace the sensor (buffer path). See "Sensor (buffer path) removal" on page 4-93. | Replace the connection. |
| 7 | <p>Check the drive motor (buffer/transport) by opening the finisher front door assembly and then closing it.</p> <p>Does the drive motor (buffer/transport) rotate normally?</p> | Go to step 9. | Go to step 8. |
| 8 | <p>Check the drive motor (buffer/transport) connection.</p> <p>Is the above motor connected properly?</p> | Replace the drive motor (buffer/transport). See "Drive motor (buffer/transport) and belt (buffer/transport) removal" on page 4-115. | Replace the connection. |

| Step | Check | Yes | No |
|------|--|--|-------------------------|
| 9 | Check the sensor (diverter gate) for correct operation. Perform the Diverter gate test. 1. Enter Diagnostics mode. 2. Select FINISHER TESTS . 3. Select Sensor Tests . 4. Select Media Path2 . 5. Select Diverter gate . Does the operator panel display change each time a piece of media is placed at the front of the sensor (diverter gate)? | Go to step 11. | Go to step 10. |
| 10 | Check the sensor (diverter gate) for connection. Is the above sensor connected properly? | Replace the sensor (diverter gate). See “Sensor (diverter gate) removal” on page 4-110. | Replace the connection. |
| 11 | Check the sensor (lower media exit) for correct operation. Perform the Lower media exit test. 1. Enter Diagnostics mode. 2. Select FINISHER TESTS . 3. Select Sensor Tests . 4. Select Media Path1 . 5. Select Lower media exit . Does the display on the operator panel change every time the actuator of the sensor (lower media exit) is operated? | Go to step 13. | Go to step 12. |
| 12 | Check the sensor (lower media exit) connection. Is the above sensor connected properly? | Replace the sensor (lower media exit). See “Sensor (lower media exit) removal” on page 4-80. | Replace the connection. |
| 13 | Perform a test print. Does the error still occur? | Replace the finisher controller card assembly. See “Finisher controller card assembly removal” on page 4-118. | Problem solved. |

284.04 Sensor (lower media exit) off jam B.

| Step | Check | Yes | No |
|------|---|--|--|
| 1 | <p>Check the media path.</p> <p>Open the finisher front door assembly of the finisher. Check lower media exit roll assembly by turning it with your fingers.</p> <p>Is the lower media exit roll assembly installed correctly?</p> | Go to step 2. | Clean or replace the lower media exit roll assembly, and clean the media path. |
| 2 | <p>Is the lower media exit roll assembly free of damage?</p> | Go to step 3. | Clean or replace the lower media exit roll assembly, and clean the media path. |
| 3 | <p>Check the sensor (lower media exit) for correct operation.</p> <p>Perform the Lower media exit test.</p> <ol style="list-style-type: none"> 1. In Diagnostics mode. 2. Select FINISHER TESTS. 3. Select Sensor Tests. 4. Select Media Path1. 5. Select Lower media exit. <p>Does the display on the operator panel change every time the actuator of the sensor (lower media exit) is operated?</p> | Go to step 5. | Go to step 4. |
| 4 | <p>Check the sensor (lower media exit) connection.</p> <p>Is the above sensor connected properly?</p> | Replace the sensor (lower media exit). See “Sensor (lower media exit) removal” on page 4-80. | Replace the connection. |
| 5 | <p>Check the drive motor (exit) by opening the finisher front door assembly and then closing it.</p> <p>Does the motor (exit) rotate normally?</p> | Go to step 7. | Go to step 6. |
| 6 | <p>Check the drive motor (exit) connection.</p> <p>Is the above motor connected properly?</p> | Replace the drive motor (exit). See “Drive motor (exit) assembly and belt (exit) removal” on page 4-113 | Replace the connection. |
| 7 | <p>Perform a test print.</p> <p>Does the error still occur?</p> | Replace the finisher controller card assembly. See “Finisher controller card assembly removal” on page 4-118. | Problem solved. |

284.05 Sensor (lower media exit) static jam

| Step | Check | Yes | No |
|------|--|--|-------------------------|
| 1 | <p>Check the sensor (lower media exit) for correct operation.</p> <p>Perform the Lower media exit test.</p> <ol style="list-style-type: none"> 1. Enter Diagnostics mode. 2. Select FINISHER TESTS. 3. Select Sensor Tests. 4. Select Media Path1. 5. Select Lower media exit. <p>Does the display on the operator panel change every time the actuator of the sensor (lower media exit) is operated?</p> | Go to step 3. | Go to step 2. |
| 2 | <p>Check the sensor (lower media exit) assembly connection.</p> <p>Is the above sensor connected properly?</p> | Replace the sensor (lower media exit). See "Sensor (lower media exit) removal" on page 4-80. | Replace the connection. |
| 3 | <p>Check the drive motor (exit) for correct operation.</p> <p>Check the above motor by opening the finisher front door assembly and then closing it.</p> <p>Does the motor (exit) rotate normally?</p> | Go to step 5. | Go to step 4. |
| 4 | <p>Check the drive motor (exit) connection.</p> <p>Is the above motor connected properly?</p> | Replace the drive motor (exit). See "Drive motor (exit) assembly and belt (exit) removal" on page 4-113. | Replace the connection. |
| 5 | <p>Perform a test print.</p> <p>Does the error still occur?</p> | Replace the finisher controller card assembly. See "Finisher controller card assembly removal" on page 4-118. | Problem solved. |

285.00 Finisher eject set jam

| Step | Check | Yes | No |
|------|---|---------------|---|
| 1 | <p>Check the media path.</p> <p>Check the media eject shaft by turning it with your fingers.</p> <p>Is the media eject shaft assembly installed correctly, meaning does it rotate smoothly?</p> | Go to step 2. | Clean or replace the media eject shaft assembly and clean the media path. |
| 2 | <p>Check the media eject clamp motor by opening the finisher front door assembly, and then closing it.</p> <p>Does the media eject clamp motor rotate normally?</p> | Go to step 4. | Go to step 3. |

| Step | Check | Yes | No |
|------|--|--|---|
| 3 | Check the media eject motor connection. Is the above motor connected properly? | Disconnect then reconnect the connector P8304 on the finisher controller card assembly. Perform a test print, if the error still occurs replace the media eject motor assembly. | Replace the connection. |
| 4 | Check the compiler media in actuator for correct operation. Is the actuator operating correctly? | Go to step 5. | Reinstall the compiler media in actuator. See “Sensor (compiler media in) removal” on page 4-73. |
| 5 | Check the sensor (compiler media in) for correct operation. Perform the Compiler media in test. 1. Enter Diagnostics mode. 2. Select FINISHER TESTS. 3. Select Sensor Tests. 4. Select Media Path1. 5. Select Compiler media in. Does the display on the operator panel change every time the compiler media in actuator of the sensor (compiler media in) is operated? | Go to step 7. | Go to step 6. |
| 6 | Check the sensor (compiler media in) connection. Are the connections of the compiler unit cable assembly properly connected? | Replace the sensor (compiler media in). See “Sensor (compiler media in) removal” on page 4-73. | Replace the connection. |
| 7 | Perform a test print. Does the error still occur? | Replace the finisher controller card assembly. See “Finisher controller card assembly removal” on page 4-118. | Problem solved |

286.00 Sensor (compiler media in) static jam

| Step | Check | Yes | No |
|------|---|---------------|---------------|
| 1 | Check the eject clamp motor for correct operation. Check the above motor by opening the finisher front door assembly and then closing it. Does the eject clamp motor rotate normally? | Go to step 3. | Go to step 2. |

| Step | Check | Yes | No |
|------|--|--|-------------------------|
| 2 | Check the eject clamp motor connection. Are the connections of the main drive cable assembly correctly connected? | Replace the eject clamp motor. See “Media eject clamp motor assembly removal” on page 4-66. | Replace the connector. |
| 3 | Check the sensor (compiler media in) for correct operation. Perform the Compiler media in test. 1. Enter Diagnostics mode. 2. Select FINISHER TESTS. 3. Select Sensor Tests. 4. Select Media Path1. 5. Select Compiler media in. Does the display on the operator panel change every time the actuator of the sensor (compiler media in) is operated? | Go to step 5. | Go to step 4. |
| 4 | Check the sensor (compiler media in) connection. Is the above sensor connected properly? | Replace the sensor (compiler media in). See “Sensor (compiler media in) removal” on page 4-73. | Replace the connection. |
| 5 | Check the media eject motor assembly by opening the finisher front door assembly and then closing it. Does the media eject motor assembly rotate normally? | Go to step 7. | Go to step 6. |
| 6 | Check the media eject motor assembly connection. Are the connections of the main drive cable assembly correctly connected? | Replace the media eject motor assembly. See “Media eject motor assembly removal” on page 4-78. | Replace the connection. |
| 7 | Perform a test print. Does the error still occur? | Replace the finisher controller card assembly. See “Finisher controller card assembly removal” on page 4-118. | Problem solved. |

287.00 Sensor (upper media exit) on jam A

| Step | Check | Yes | No |
|------|--|---|--|
| 1 | <p>Check the media path.</p> <ol style="list-style-type: none"> 1. Open the finisher front door assembly of the finisher. 2. Remove the top cover and left upper cover. 3. Open the entrance pinch guide assembly upward. 4. Check four media entrance pinch guide pinch rolls of the entrance pinch guide assembly and media entrance roll assembly by turning them with your fingers. <p>Are the media entrance pinch guide pinch rolls installed correctly and do they rotate smoothly?</p> | Go to step 2. | Clean or replace the appropriate roller, and clean the media path. |
| 2 | <p>Are the four media entrance pinch guide pinch rolls of the entrance pinch guide assembly and media entrance roll assembly free of damage?</p> | Go to step 3. | Clean or replace the appropriate roller and clean the media path. |
| 3 | <p>Check the media path.</p> <ol style="list-style-type: none"> 1. Open the upper pinch guide assembly to the right. 2. Check these items by turning them with your fingers. <p>Are the four upper pinch guide pinch rolls of the upper pinch guide assembly and two upper media transport roll assemblies installed correctly, meaning do they rotate smoothly?</p> | Go to step 4. | Clean or replace the appropriate roller and clean the media path. |
| 4 | <p>Are the four upper pinch guide pinch rolls of the upper pinch guide assembly and two upper media transport roll assemblies free of damage?</p> | Go to step 5. | Clean or replace the appropriate roller and clean the media path. |
| 5 | <p>Check the sensor (upper media exit) for correct operation.</p> <p>Perform the Upper media exit test.</p> <ol style="list-style-type: none"> 1. Enter Diagnostics mode. 2. Select FINISHER TESTS. 3. Select Sensor Tests. 4. Select Media Path1. 5. Select Upper media exit. <p>Does the display on the operator panel change every time the actuator of the sensor (upper media exit) is operated?</p> | Go to step 7. | Go to step 6. |
| 6 | <p>Check the sensor (upper media exit) and main sensor cable assembly connections</p> <p>Is the above sensor connected properly?</p> | Replace the sensor (upper media exit). “Sensor (upper media exit) removal” on page 4-104. | Replace the connection. |
| 7 | <p>Check the drive motor (buffer/transport) by opening the finisher front door assembly and then closing it.</p> <p>Does the drive motor (buffer/transport) rotate properly?</p> | Go to step 9. | Go to step 8. |

| Step | Check | Yes | No |
|------|--|--|-------------------------|
| 8 | Check the drive motor (buffer/transport/connection). Is the above motor properly connected? | Replace the drive motor (buffer/transport). See “Drive motor (buffer/transport) and belt (buffer/transport) removal” on page 4-115. | Replace the connection. |
| 9 | Perform a test print. Does the error still occur? | Replace the finisher controller card assembly. See “Finisher controller card assembly removal” on page 4-118. | Problem solved. |

287.01 Sensor (upper media exit) off jam A.

| Step | Check | Yes | No |
|------|--|--|---|
| 1 | Check the media path. 1. Open the upper pinch guide assembly to the right. 2. Check four upper pinch guide pinch roll on the upper pinch guide assembly and two upper media transport roll assemblies by turning them with your fingers. Are the upper pinch guide pinch roll and upper media transport roll assemblies installed correctly and do they rotate smoothly? | Go to step 2. | Clean or replace the appropriate roller and clean the media path. |
| 2 | Are the four upper pinch guide pinch rolls on the upper pinch guide assembly and two upper media transport roll assemblies free of damage? | Go to step 3. | Clean or replace the appropriate roller and clean the media path. |
| 3 | Check the sensor (upper media exit) for correct operation. Perform the Upper media exit test. 1. Enter Diagnostics mode. 2. Select FINISHER TESTS. 3. Select Sensor Tests. 4. Select Media Path1. 5. Select Upper media exit. Does the display on the operator panel change every time the actuator of the sensor (upper media exit) is operated? | Replace the finisher controller card assembly. See “Finisher controller card assembly removal” on page 4-118. | Go to step 4. |
| 4 | Check the sensor (upper media exit) and main sensor cable assembly connections. Is the above sensor connected properly? | Replace the sensor (upper media exit). See “Sensor (upper media exit) removal” on page 4-104. | Replace the connection. |

| Step | Check | Yes | No |
|------|--|--|-------------------------|
| 5 | Check the drive motor (buffer/transport) for rotation. Check the above motor by opening the finisher front door assembly and then closing it. Does the drive motor (buffer/transport) rotate properly? | Go to step 7. | Go to step 6. |
| 6 | Check the drive motor (buffer/transport) connection. Is the above motor connected properly? | Replace drive motor (buffer/transport). See “Drive motor (buffer/transport) and belt (buffer/transport) removal” on page 4-115. | Replace the connection. |
| 7 | Check the drive motor (exit) for correct operation. Check the above motor by opening the finisher front door assembly and then closing it. Does the motor (exit) rotate normally? | Go to step 9. | Go to step 8. |
| 8 | Check the drive motor (exit) connection. Is the above motor connected properly? | Replace the drive motor (exit). See “Drive motor (exit) assembly and belt (exit) removal” on page 4-113. | Replace the connection. |
| 9 | Perform a test print. Does the error still occur? | Replace the finisher controller card assembly. See “Finisher controller card assembly removal” on page 4-118. | Problem solved. |

287.02 Sensor (upper media exit) on jam B

| Step | Check | Yes | No |
|------|--|---------------|--|
| 1 | Check the media path. 1. Open the finisher front door assembly of the finisher. 2. Remove the top cover and left upper cover. 3. Open the entrance pinch guide assembly upward. 4. Check four media entrance pinch guide pinch rolls of the entrance pinch guide assembly and media entrance roll assembly by turning them with your fingers. Are the media entrance pinch guide pinch rolls installed correctly and do they rotate smoothly? | Go to step 2. | Clean or replace the appropriate roller, and clean the media path. |
| 2 | Are the four media entrance pinch guide pinch rolls of the entrance pinch guide assembly and media entrance roll assembly free of damage? | Go to step 3. | Clean or replace the appropriate roller and clean the media path. |

| Step | Check | Yes | No |
|------|--|--|---|
| 3 | <p>Check the media path.</p> <ol style="list-style-type: none"> 1. Open the upper pinch guide assembly to the right. 2. Check these items by turning them with your fingers. <p>Are the four upper pinch guide pinch rolls of the upper pinch guide assembly and two upper media transport roll assemblies installed correctly, meaning do they rotate smoothly?</p> | Go to step 4. | Clean or replace the appropriate roller and clean the media path. |
| 4 | <p>Are the four upper pinch guide pinch rolls of the upper pinch guide assembly and two upper media transport roll assemblies free of damage?</p> | Go to step 5. | Clean or replace the appropriate roller and clean the media path. |
| 5 | <p>Check the sensor (upper media exit) for correct operation.</p> <p>Perform the Upper media exit test.</p> <ol style="list-style-type: none"> 1. Enter Diagnostics mode. 2. Select FINISHER TESTS. 3. Select Sensor Tests. 4. Select Media Path1. 5. Select Upper media exit. <p>Does the display on the operator panel change every time the actuator of the sensor (upper media exit) is operated?</p> | Go to step 7. | Go to step 6. |
| 6 | <p>Check the sensor (upper media exit) and main sensor cable assembly connections</p> <p>Is the above sensor connected properly?</p> | Replace the sensor (upper media exit). “Sensor (upper media exit) removal” on page 4-104. | Replace the connection. |
| 7 | <p>Check the drive motor (buffer/transport) by opening the finisher front door assembly and then closing it.</p> <p>Does the drive motor (buffer/transport) rotate properly?</p> | Go to step 9. | Go to step 8. |
| 8 | <p>Check the drive motor (buffer/transport/connection).</p> <p>Is the above motor properly connected?</p> | Replace the drive motor (buffer/transport). See “Drive motor (buffer/transport) and belt (buffer/transport) removal” on page 4-115. | Replace the connection. |
| 9 | <p>Perform a test print.</p> <p>Does the error still occur?</p> | Replace the finisher controller card assembly. See “Finisher controller card assembly removal” on page 4-118. | Problem solved. |

287.03 Sensor (upper media exit) on jam C

| Step | Check | Yes | No |
|------|--|---|--|
| 1 | <p>Check the media path.</p> <ol style="list-style-type: none"> 1. Open the finisher front door assembly of the finisher. 2. Remove the top cover and left upper cover. 3. Open the entrance pinch guide assembly upward. 4. Check four media entrance pinch guide pinch rolls of the entrance pinch guide assembly and media entrance roll assembly by turning them with your fingers. <p>Are the media entrance pinch guide pinch rolls installed correctly and do they rotate smoothly?</p> | Go to step 2. | Clean or replace the appropriate roller, and clean the media path. |
| 2 | <p>Are the four media entrance pinch guide pinch rolls of the entrance pinch guide assembly and media entrance roll assembly free of damage?</p> | Go to step 3. | Clean or replace the appropriate roller and clean the media path. |
| 3 | <p>Check the media path.</p> <ol style="list-style-type: none"> 1. Open the upper pinch guide assembly to the right. 2. Check these items by turning them with your fingers. <p>Are the four upper pinch guide pinch rolls of the upper pinch guide assembly and two upper media transport roll assemblies installed correctly, meaning do they rotate smoothly?</p> | Go to step 4. | Clean or replace the appropriate roller and clean the media path. |
| 4 | <p>Are the four upper pinch guide pinch rolls of the upper pinch guide assembly and two upper media transport roll assemblies free of damage?</p> | Go to step 5. | Clean or replace the appropriate roller and clean the media path. |
| 5 | <p>Check the sensor (upper media exit) for correct operation.</p> <p>Perform the Upper media exit test.</p> <ol style="list-style-type: none"> 1. Enter Diagnostics mode. 2. Select FINISHER TESTS. 3. Select Sensor Tests. 4. Select Media Path1. 5. Select Upper media exit. <p>Does the display on the operator panel change every time the actuator of the sensor (upper media exit) is operated?</p> | Go to step 7. | Go to step 6. |
| 6 | <p>Check the sensor (upper media exit) and main sensor cable assembly connections</p> <p>Is the above sensor connected properly?</p> | Replace the sensor (upper media exit). “Sensor (upper media exit) removal” on page 4-104. | Replace the connection. |
| 7 | <p>Check the drive motor (buffer/transport) by opening the finisher front door assembly and then closing it.</p> <p>Does the drive motor (buffer/transport) rotate properly?</p> | Go to step 9. | Go to step 8. |

| Step | Check | Yes | No |
|------|--|--|-------------------------|
| 8 | Check the drive motor (buffer/transport/connection). Is the above motor properly connected? | Replace the drive motor (buffer/transport). See “Drive motor (buffer/transport) and belt (buffer/transport) removal” on page 4-115. | Replace the connection. |
| 9 | Perform a test print. Does the error still occur? | Replace the finisher controller card assembly. See “Finisher controller card assembly removal” on page 4-118. | Problem solved. |

287.04 Sensor (upper media exit) off jam B.

| Step | Check | Yes | No |
|------|--|--|---|
| 1 | Check the media path. 1. Open the upper pinch guide assembly to the right. 2. Check four upper pinch guide pinch roll on the upper pinch guide assembly and two upper media transport roll assemblies by turning them with your fingers. Are the upper pinch guide pinch roll and upper media transport roll assemblies installed correctly and do they rotate smoothly? | Go to step 2. | Clean or replace the appropriate roller and clean the media path. |
| 2 | Are the four upper pinch guide pinch rolls on the upper pinch guide assembly and two upper media transport roll assemblies free of damage? | Go to step 3. | Clean or replace the appropriate roller and clean the media path. |
| 3 | Check the sensor (upper media exit) for correct operation. Perform the Upper media exit test. 1. Enter Diagnostics mode. 2. Select FINISHER TESTS. 3. Select Sensor Tests. 4. Select Media Path1. 5. Select Upper media exit. Does the display on the operator panel change every time the actuator of the sensor (upper media exit) is operated? | Replace the finisher controller card assembly. See “Finisher controller card assembly removal” on page 4-118. | Go to step 4. |
| 4 | Check the sensor (upper media exit) and main sensor cable assembly connections. Is the above sensor connected properly? | Replace the sensor (upper media exit). See “Sensor (upper media exit) removal” on page 4-104. | Replace the connection. |

| Step | Check | Yes | No |
|------|--|--|-------------------------|
| 5 | Check the drive motor (buffer/transport) for rotation. Check the above motor by opening the finisher front door assembly and then closing it. Does the drive motor (buffer/transport) rotate properly? | Go to step 7. | Go to step 6. |
| 6 | Check the drive motor (buffer/transport) connection. Is the above motor connected properly? | Replace drive motor (buffer/transport). See “Drive motor (buffer/transport) and belt (buffer/transport) removal” on page 4-115. | Replace the connection. |
| 7 | Check the drive motor (exit) for correct operation. Check the above motor by opening the finisher front door assembly and then closing it. Does the motor (exit) rotate normally? | Go to step 9. | Go to step 8. |
| 8 | Check the drive motor (exit) connection. Is the above motor connected properly? | Replace the drive motor (exit). See “Drive motor (exit) assembly and belt (exit) removal” on page 4-113. | Replace the connection. |
| 9 | Perform a test print. Does the error still occur? | Replace the finisher controller card assembly. See “Finisher controller card assembly removal” on page 4-118. | Problem solved. |

287.05 Sensor (upper media exit) static jam A

| Step | Check | Yes | No |
|------|--|---------------|---------------|
| 1 | Check the sensor (upper media exit) for correct operation. Perform the Upper media exit test. 1. Enter Diagnostics mode. 2. Select FINISHER TESTS . 3. Select Sensor Tests . 4. Select Media Path1 . 5. Select Upper media exit . Does the display on the operator panel change every time the actuator of the sensor (upper media exit) is operated? | Go to step 3. | Go to step 2. |

| Step | Check | Yes | No |
|------|---|--|-------------------------|
| 2 | Check the sensor (upper media exit) and main sensor cable assembly connection. Is the above sensor connected properly? | Replace the sensor (upper media exit). See “Sensor (upper media exit) removal” on page 4-104. | Replace the connection. |
| 3 | Check the drive motor (buffer/transport) by opening the finisher front door assembly and then closing it. Does the drive motor (buffer/transport) rotate normally? | Go to step 5. | Go to step 4. |
| 4 | Check the drive motor (buffer/transport) connection. Is the above motor connected properly? | Replace the drive motor (buffer/transport). See “Drive motor (buffer/transport) and belt (buffer/transport) removal” on page 4-115. | Replace the connection. |
| 5 | Perform a test print. Does the error still occur? | Replace the finisher controller card assembly. See “Finisher controller card assembly removal” on page 4-118. | Problem solved. |

287.06 Sensor (upper media exit) static jam B

| Step | Check | Yes | No |
|------|--|--|-------------------------|
| 1 | Check the sensor (upper media exit) for correct operation. Perform the Upper media exit test. 1. Enter Diagnostics mode. 2. Select FINISHER TESTS . 3. Select Sensor Tests . 4. Select Media Path1 . 5. Select Upper media exit . Does the display on the operator panel change every time the actuator of the sensor (upper media exit) is operated? | Go to step 3. | Go to step 2. |
| 2 | Check the sensor (upper media exit) and main sensor cable assembly connection. Is the above sensor connected properly? | Replace the sensor (upper media exit). See “Sensor (upper media exit) removal” on page 4-104. | Replace the connection. |

| Step | Check | Yes | No |
|------|---|--|-------------------------|
| 3 | Check the drive motor (buffer/transport) by opening the finisher front door assembly and then closing it. Does the drive motor (buffer/transport) rotate normally? | Go to step 5. | Go to step 4. |
| 4 | Check the drive motor (buffer/transport) connection. Is the above motor connected properly? | Replace the drive motor (buffer/transport). See “Drive motor (buffer/transport) and belt (buffer/transport) removal” on page 4-115. | Replace the connection. |
| 5 | Perform a test print. Does the error still occur? | Replace the finisher controller card assembly. See “Finisher controller card assembly removal” on page 4-118. | Problem solved. |

287.07 Sensor (upper media exit) static jam C

| Step | Check | Yes | No |
|------|--|--|-------------------------|
| 1 | Check the sensor (upper media exit) for correct operation. Perform the Upper media exit test. 1. Enter Diagnostics mode. 2. Select FINISHER TESTS . 3. Select Sensor Tests . 4. Select Media Path1 . 5. Select Upper media exit . Does the display on the operator panel change every time the actuator of the sensor (upper media exit) is operated? | Go to step 3. | Go to step 2. |
| 2 | Check the sensor (upper media exit) and main sensor cable assembly connection. Is the above sensor connected properly? | Replace the sensor (upper media exit). See “Sensor (upper media exit) removal” on page 4-104. | Replace the connection. |
| 3 | Check the drive motor (buffer/transport) by opening the finisher front door assembly and then closing it. Does the drive motor (buffer/transport) rotate normally? | Go to step 5. | Go to step 4. |

| Step | Check | Yes | No |
|------|--|--|-------------------------|
| 4 | Check the drive motor (buffer/transport) connection. Is the above motor connected properly? | Replace the drive motor (buffer/transport). See “Drive motor (buffer/transport) and belt (buffer/transport) removal” on page 4-115. | Replace the connection. |
| 5 | Perform a test print. Does the error still occur? | Replace the finisher controller card assembly. See “Finisher controller card assembly removal” on page 4-118. | Problem solved. |

288.00 Sensor (diverter gate) on jam

| Step | Check | Yes | No |
|------|---|---------------|--|
| 1 | Check the media path. 1. Open the bridge unit top cover assembly of the bridge unit assembly. 2. Check the six bridge unit pinch rolls on the bridge unit top cover assembly and the two transport belts by turning them with your fingers. Are the bridge unit pinch rolls and transport belts installed correctly? | Go to step 2. | Clean or replace the appropriate transport belts and bridge unit pinch roll, and clean the media path. |
| 2 | Are the six bridge unit pinch rolls on the bridge unit top cover assembly and two transport belts free of damage. | Go to step 3. | Clean or replace the appropriate transport belts and bridge unit pinch roll, and clean the media path. |
| 3 | Check the media path. 1. Open the finisher front door assembly of the finisher. 2. Remove the top cover and left upper cover. 3. Open the entrance pinch guide assembly to upward. 4. Check the media entrance pinch guide pinch roll on the entrance pinch guide assembly and media entrance roll assembly by turning them with your fingers. Are the media entrance pinch guide pinch roll and media entrance roll assembly installed correctly? | Go to step 4. | Clean or replace the appropriate transport belts and bridge unit pinch roll, and clean the media path. |

| Step | Check | Yes | No |
|------|--|--|--|
| 4 | Are the media entrance pinch guide pinch roll on the entrance pinch guide assembly and media entrance roll assembly free of damage? | Go to step 5. | Clean or replace the appropriate transport belts and bridge unit pinch roll, and clean the media path. |
| 5 | Check the sensor (bridge unit media exit) for correct operation. Perform the Bridge media exit test. 1. Enter Diagnostics mode. 2. Select FINISHER TESTS . 3. Select Sensor Tests . 4. Select Media Path1 . 5. Select Bridge media exit . Does the display on the operator panel change every time the actuator of the sensor (bridge unit media exit) is operated? | Go to step 7. | Go to step 6 |
| 6 | Check the sensor (bridge unit media exit) connection. Is the above sensor connected properly? | Replace the sensor (bridge unit media exit). See " Sensor (bridge unit media exit) removal " on page 4-17. | Replace the connection. |
| 7 | Check the sensor (finisher media entrance) for correct operation. Perform the Fin media ent test. 1. Enter Diagnostics mode. 2. Select FINISHER TESTS . 3. Select Sensor Tests . 4. Select Media Path1 . 5. Select Fin media ent . Does the display change, every time a piece of white media is placed over the sensor (finisher media entrance)? | Go to step 9. | Go to step 8. |
| 8 | Check the sensor (finisher media entrance) connection. Is the above sensor connected properly? | Replace the sensor (finisher media entrance). See " Sensor (finisher media entrance) removal " on page 4-98. | Replace the connection. |
| 9 | Check the sensor (diverter gate) for correct operation. Perform the Diverter gate test. 1. Enter Diagnostics mode. 2. Select FINISHER TESTS . 3. Select Sensor Tests . 4. Select Media Path2 . 5. Select Diverter gate . Does the display on the operator panel change every time a piece of white media is placed over the sensing area of the sensor (diverter gate)? | Go to step 11. | Go to step 10. |

| Step | Check | Yes | No |
|------|--|---|-------------------------|
| 10 | Check the sensor (diverter gate) connection. Are the connectors of the diverter gate sensor cable assembly correctly connected? | Replace the sensor (diverter gate). See “Sensor (diverter gate) removal” on page 4-110. | Replace the connection. |
| 11 | Check the drive motor (entrance/paddle) for correct operation. Check the above motor by opening the finisher front door assembly and then closing it. Does the motor (entrance/paddle) rotate normally? | Go to step 13. | Go to step 12. |
| 12 | Check the drive motor (entrance/paddle) connection. Are the connections of the main drive cable assembly correctly connected? | Replace the drive motor (entrance/paddle). See “Drive motor (entrance/paddle) and belt (entrance/paddle) removal” on page 4-100. | Replace the connection. |
| 13 | Perform a test print. Does the error still occur? | Replace the finisher controller card assembly. See “Finisher controller card assembly removal” on page 4-118. | Problem solved. |

288.01 Sensor (diverter gate) static jam (to top bin) A

| Step | Check | Yes | No |
|------|--|--|-------------------------|
| 1 | Check the sensor (diverter gate) for correct operation. Perform the Diverter gate test. 1. Enter Diagnostics mode. 2. Select FINISHER TESTS . 3. Select Sensor Tests . 4. Select Media Path2 . 5. Select Diverter gate . Does the display on the operator panel change every time a piece of white media is placed over the sensing area of the sensor (diverter gate)? | Go to step 3. | Go to step 2. |
| 2 | Check the sensor (diverter gate) connection. Is the above sensor connected properly? | Replace the sensor (diverter gate). See “Sensor (diverter gate) removal” on page 4-110. | Replace the connection. |

| Step | Check | Yes | No |
|------|---|---|-------------------------|
| 3 | Check the drive motor (entrance/paddle) by opening the finisher front door assembly and then closing it. Does the motor (entrance/paddle) rotate normally? | Go to step 5. | Go to step 4. |
| 4 | Is the drive motor (entrance/paddle) connected properly? | Replace the drive motor (entrance/paddle). See “Drive motor (entrance/paddle) and belt (entrance/paddle) removal” on page 4-100. | Replace the connection. |
| 5 | Perform a test print. Does the error still occur? | Replace the finisher controller card assembly. See “Finisher controller card assembly removal” on page 4-118. | Problem solved. |

288.02 Sensor (diverter gate) static jam (to top bin) B

| Step | Check | Yes | No |
|------|--|--|-------------------------|
| 1 | Check the sensor (diverter gate) for correct operation. Perform the Diverter gate test. 1. Enter Diagnostics mode. 2. Select FINISHER TESTS . 3. Select Sensor Tests . 4. Select Media Path2 . 5. Select Diverter gate . Does the display on the operator panel change every time a piece of white media is placed over the sensing area of the sensor (diverter gate)? | Go to step 3. | Go to step 2. |
| 2 | Check the sensor (diverter gate) connection. Is the above sensor connected properly? | Replace the sensor (diverter gate). See “Sensor (diverter gate) removal” on page 4-110. | Replace the connection. |
| 3 | Check the drive motor (entrance/paddle) by opening the finisher front door assembly and then closing it. Does the motor (entrance/paddle) rotate normally? | Go to step 5. | Go to step 4. |

| Step | Check | Yes | No |
|------|--|---|-------------------------|
| 4 | Is the drive motor (entrance/paddle) connected properly? | Replace the drive motor (entrance/paddle). See “Drive motor (entrance/paddle) and belt (entrance/paddle) removal” on page 4-100. | Replace the connection. |
| 5 | Perform a test print. Does the error still occur? | Replace the finisher controller card assembly. See “Finisher controller card assembly removal” on page 4-118. | Problem solved. |

288.03 Sensor (diverter gate) static jam (to top bin) C

| Step | Check | Yes | No |
|------|--|---|-------------------------|
| 1 | Check the sensor (diverter gate) for correct operation. Perform the Diverter gate test. 1. Enter Diagnostics mode. 2. Select FINISHER TESTS . 3. Select Sensor Tests . 4. Select Media Path2 . 5. Select Diverter gate . Does the display on the operator panel change every time a piece of white media is placed over the sensing area of the sensor (diverter gate)? | Go to step 3. | Go to step 2. |
| 2 | Check the sensor (diverter gate) connection. Is the above sensor connected properly? | Replace the sensor (diverter gate). See “Sensor (diverter gate) removal” on page 4-110. | Replace the connection. |
| 3 | Check the drive motor (entrance/paddle) by opening the finisher front door assembly and then closing it. Does the motor (entrance/paddle) rotate normally? | Go to step 5. | Go to step 4. |
| 4 | Is the drive motor (entrance/paddle) connected properly? | Replace the drive motor (entrance/paddle). See “Drive motor (entrance/paddle) and belt (entrance/paddle) removal” on page 4-100. | Replace the connection. |

| Step | Check | Yes | No |
|------|--|--|-----------------|
| 5 | Perform a test print. Does the error still occur? | Replace the finisher controller card assembly. See “Finisher controller card assembly removal” on page 4-118. | Problem solved. |

288.04 Sensor (diverter gate) static jam (to stacker bin) A

| Step | Check | Yes | No |
|------|--|---|-------------------------|
| 1 | Check the sensor (diverter gate) for correct operation. Perform the Diverter gate test. 1. Enter Diagnostics mode. 2. Select FINISHER TESTS . 3. Select Sensor Tests . 4. Select Media Path2 . 5. Select Diverter gate . Does the display on the operator panel change every time a piece of white media is placed over the sensing area of the sensor (diverter gate)? | Go to step 3. | Go to step 2. |
| 2 | Is the sensor (diverter gate) connected properly? | Replace the sensor (diverter gate). See “Sensor (diverter gate) removal” on page 4-110. | Replace the connection. |
| 3 | Check the drive motor (entrance/paddle) by opening the finisher front door assembly and then closing it. Does the motor (entrance/paddle) rotate normally? | Go to step 5. | Go to step 4. |
| 4 | Check the main drive cable assembly connection. Are the connections of the main drive cable assembly correctly connected? | Replace the drive motor (entrance/paddle). See “Drive motor (entrance/paddle) and belt (entrance/paddle) removal” on page 4-100. | Replace the connection. |
| 5 | Perform a test print. Does the error still occur? | Replace the finisher controller card assembly. See “Finisher controller card assembly removal” on page 4-118. | Problem solved. |

288.05 Sensor (diverter gate) static jam (to stacker bin) B

| Step | Check | Yes | No |
|------|---|---|-------------------------|
| 1 | <p>Check the sensor (diverter gate) for correct operation. Perform the Diverter gate test.</p> <ol style="list-style-type: none"> 1. Enter Diagnostics mode. 2. Select FINISHER TESTS. 3. Select Sensor Tests. 4. Select Media Path2. 5. Select Diverter gate. <p>Does the display on the operator panel change every time a piece of white media is placed over the sensing area of the sensor (diverter gate)?</p> | Go to step 3. | Go to step 2. |
| 2 | Is the sensor (diverter gate) connected properly? | Replace the sensor (diverter gate). See "Sensor (diverter gate) removal" on page 4-110. | Replace the connection. |
| 3 | <p>Check the drive motor (entrance/paddle) by opening the finisher front door assembly and then closing it. Does the motor (entrance/paddle) rotate normally?</p> | Go to step 5. | Go to step 4. |
| 4 | <p>Check the main drive cable assembly connection. Are the connections of the main drive cable assembly correctly connected?</p> | Replace the drive motor (entrance/paddle). See "Drive motor (entrance/paddle) and belt (entrance/paddle) removal" on page 4-100. | Replace the connection. |
| 5 | <p>Perform a test print. Does the error still occur?</p> | Replace the finisher controller card assembly. See "Finisher controller card assembly removal" on page 4-118. | Problem solved. |

288.06 Sensor (diverter gate) static jam (to stacker bin) C

| Step | Check | Yes | No |
|------|---|---|-------------------------|
| 1 | <p>Check the sensor (diverter gate) for correct operation. Perform the Diverter gate test.</p> <ol style="list-style-type: none"> 1. Enter Diagnostics mode. 2. Select FINISHER TESTS. 3. Select Sensor Tests. 4. Select Media Path2. 5. Select Diverter gate. <p>Does the display on the operator panel change every time a piece of white media is placed over the sensing area of the sensor (diverter gate)?</p> | Go to step 3. | Go to step 2. |
| 2 | Is the sensor (diverter gate) connected properly? | Replace the sensor (diverter gate). See "Sensor (diverter gate) removal" on page 4-110. | Replace the connection. |
| 3 | <p>Check the drive motor (entrance/paddle) by opening the finisher front door assembly and then closing it. Does the motor (entrance/paddle) rotate normally?</p> | Go to step 5. | Go to step 4. |
| 4 | <p>Check the main drive cable assembly connection. Are the connections of the main drive cable assembly correctly connected?</p> | Replace the drive motor (entrance/paddle). See "Drive motor (entrance/paddle) and belt (entrance/paddle) removal" on page 4-100. | Replace the connection. |
| 5 | <p>Perform a test print. Does the error still occur?</p> | Replace the finisher controller card assembly. See "Finisher controller card removal" on page 4-118. | Problem solved. |

980.02 Finisher communication failure

| Step | Check | Yes | No |
|------|---|---------------|-----------------------------------|
| 1 | <p>Check the printer and finisher installation. Is the finisher installed to the printer correctly?</p> | Go to step 2. | After reinstalling, go to step 2. |
| 2 | <p>Turn the power on and off. Does the error still occur when the power is on?</p> | Go to step 3. | Problem solved. |

| Step | Check | Yes | No |
|------|--|---|-------------------------|
| 3 | Check the finisher controller card assembly connection. Are the connections of the finisher controller card assembly correctly connected? | Replace the finisher controller card assembly. See “Finisher controller card assembly removal” on page 4-118. Go to step 4. | Replace the connection. |
| 4 | Perform a test print. Does the problem remain. | Replace the printer engine card assembly. Refer to the <i>Printer Service Manual</i> . | Problem solved. |

981.00 Stacker bin failure

| Step | Check | Yes | No |
|------|---|---|-------------------------|
| 1 | Check the vertical transport mechanism of the stacker bin for obstacles and deformation. Are there any obstacles in the vertical transport mechanism of the stacker bin? | Remove obstacles. | Go to step 2. |
| 2 | Is there any deformation in the vertical transport mechanism of the stacker bin? | Replace deformed part. | Go to step 3 |
| 3 | Check the sensor (stacker bin level 1) for correct operation. Perform the Stacker bin level1 test. 1. Enter Diagnostics mode. 2. Select FINISHER TESTS . 3. Select Sensor Tests . 4. Select Bin Level . 5. Select Stacker bin level1 . Does the display on the operator panel change every time the sensing area of the sensor (stacker bin level 1) is blocked by a multi page document or your finger? | Go to step 5. | Go to step 4. |
| 4 | Is the sensor (stacker bin level 1) connected properly? | Replace the sensor (stacker bin level 1). See “Sensor (stacker bin level 1) removal” on page 4-34. | Replace the connection. |

| Step | Check | Yes | No |
|------|---|--|-------------------------|
| 5 | <p>Check the sensor (stacker bin level 2) for correct operation.</p> <p>Perform the Stacker bin level 2 test.</p> <ol style="list-style-type: none"> 1. Enter Diagnostics mode. 2. Select FINISHER TESTS. 3. Select Sensor Tests. 4. Select Bin Level. 5. Select Stacker bin level2. <p>Does the display on the operator panel change every time the sensing area of the sensor (stacker bin level 2) is blocked by putting a piece of media or your finger?</p> | Go to step 7. | Go to step 6. |
| 6 | Is the sensor (stacker bin level 2) connected properly | Replace the sensor (stacker bin level 2). See “Sensor (stacker bin level 2) removal” on page 4-34. | Replace the connection. |
| 7 | <p>Check the stacker bin lift motor assembly by blocking the lower hole in either of the sensor (stacker bin level). The stacker bin should lower slightly.</p> <p>Does the stacker bin lift motor assembly rotate normally?</p> | Go to step 9. | Go to step 8. |
| 8 | Is the stacker bin lift motor assembly connected properly? | Replace the stacker bin lift motor assembly. See “Stacker bin lift motor assembly removal” on page 4-38. | Replace the connection. |
| 9 | <p>Perform a test print.</p> <p>Does the error still occur?</p> | Replace the finisher controller card assembly. See “Finisher controller card assembly removal” on page 4-118. | Problem solved. |

981.01 Stacker bin upper limit failure

| Step | Check | Yes | No |
|------|--|---|--|
| 1 | <p>Check the sensor (stacker bin level 1) for correct operation.</p> <p>Perform the Stacker bin level 2 test.</p> <ol style="list-style-type: none"> 1. Enter Diagnostics mode. 2. Select FINISHER TESTS. 3. Select Sensor Tests. 4. Select Bin Level. 5. Select Stacker bin level1. <p>Does the display on the operator panel change every time the sensing area of the sensor (stacker bin level 1) is blocked by putting a piece of media or your finger over the sensor area?</p> | Go to step 3. | Go to step 2. |
| 2 | <p>Check the sensor (stacker bin level 1) connection.</p> <p>Are the connections of the main sensor cable assembly properly connected?</p> | Replace the sensor (stacker bin level 1). See “Sensor (stacker bin level 1) removal” on page 4-34. | Replace the connection. |
| 3 | <p>Check the sensor (stacker bin level 2) for correct operation.</p> <p>Perform the Stacker bin level 2 test.</p> <ol style="list-style-type: none"> 1. Enter Diagnostics mode. 2. Select FINISHER TESTS. 3. Select Sensor Tests. 4. Select Bin Level. 5. Select Stacker bin level2. <p>Does the display on the operator panel change every time the sensing area of the sensor (stacker bin level 2) is blocked by a multi page document or your finger?</p> | Go to step 5. | Go to step 4. |
| 4 | <p>Check the sensor (stacker bin level 2) connection.</p> <p>Are the connections of the main sensor cable assembly correctly connected?</p> | Replace the sensor (stacker bin level 2). See “Sensor (stacker bin level 2) removal” on page 4-34. | Replace the connection. |
| 5 | <p>Check the media stacker bin actuator for correct operation.</p> <p>Is the media stacker bin actuator installed correctly?</p> <p>Does it enter the sensing area of the sensor (stacker bin upper limit)?</p> | Go to step 6. | Repair the media stacker bin actuator. |

| Step | Check | Yes | No |
|------|---|--|-------------------------|
| 6 | <p>Check the sensor (stacker bin upper limit) for correct operation.</p> <p>Perform the Stacker bin upper limit test.</p> <ol style="list-style-type: none"> 1. Enter Diagnostics mode. 2. Select FINISHER TESTS. 3. Select Sensor Tests. 4. Select Bin Level. 5. Select Stacker bin upper limit. <p>Does the display on the operator panel change every time the sensing area of the sensor (stacker bin upper limit) is blocked?</p> | Go to step 8. | Go to step 7. |
| 7 | <p>Check the sensor (stacker bin upper limit) connection.</p> <p>Are the connections of the main sensor cable assembly correctly connected?</p> | Replace the sensor (stacker bin upper limit). See " Sensor (stacker bin upper limit) or sensor (stacker bin no media) removal " on page 4-36. | Replace the connection. |
| 8 | <p>Check the stacker bin lift motor assembly by blocking the lower hole in either of the sensors (stacker bin level). The stacker bin should lower slightly.</p> <p>Does the stacker bin lift motor assembly rotate normally?</p> | Go to step 10. | Go to step 9. |
| 9 | <p>Check the stacker bin lift motor assembly connection.</p> <p>Is the connection of the stacker bin lift motor assembly connected to the finisher controller card assembly securely?</p> | Replace the stacker bin lift motor assembly. Go to " Stacker bin lift motor assembly removal " on page 4-38. | Replace the connection. |
| 10 | <p>Perform a test print.</p> <p>Does the error still occur?</p> | Replace the printer engine card assembly. Refer to the <i>Printer Service Manual</i> . | Problem solved. |

981.02 Stacker bin lower limit failure

| Step | Check | Yes | No |
|------|---|---------------|--|
| 1 | <p>Check the media stacker bin actuator for correct operation.</p> <p>Is the media stacker bin actuator installed correctly?</p> <p>Does it enter the sensing area of the sensor (stacker bin upper limit)?</p> | Go to step 2. | Repair the media stacker bin actuator. |

| Step | Check | Yes | No |
|------|--|---|-------------------------|
| 2 | <p>Check the sensor (stacker bin no media) for correct operation.</p> <p>Perform the Stacker bin no media test.</p> <ol style="list-style-type: none"> 1. Enter Diagnostics mode. 2. Select FINISHER TESTS. 3. Select Sensor Tests. 4. Select Bin Level. 5. Select Stacker bin no media. <p>Does the display on the operator panel change every time the sensing area of the sensor (stacker bin no media) is blocked?</p> | Go to step 4. | Go to step 3. |
| 3 | <p>Is the sensor (stacker bin no media) connected properly?</p> | Replace the sensor (stacker bin no media). | Replace the connection. |
| 4 | <p>Check the sensor (stacker bin level 1) for correct operation.</p> <p>Perform the Stacker bin level1 test.</p> <ol style="list-style-type: none"> 1. Enter Diagnostics mode. 2. Select FINISHER TESTS. 3. Select Sensor Tests. 4. Select Bin Level. 5. Select Stacker bin level1. <p>Does the display on the operator panel change every time the sensing area of the sensor (stacker bin level 1) is blocked by a multi page document or your finger?</p> | Go to step 6. | Go to step 5. |
| 5 | <p>Is the sensor (stacker bin level 1) connected properly?</p> | Replace the sensor (stacker bin level 1). See “Sensor (stacker bin level 1) removal” on page 4-34. | Replace the connection. |
| 6 | <p>Check the sensor (stacker bin level 2) for correct operation.</p> <p>Perform the Stacker bin level2 test.</p> <ol style="list-style-type: none"> 1. Enter Diagnostics mode. 2. Select FINISHER TESTS. 3. Select Sensor Tests. 4. Select Bin Level. 5. Select Stacker bin level2. <p>Does the display on the operator panel change every time the sensing area of the sensor (stacker bin level rear) is blocked by a multi page document or your finger?</p> | Go to step 8. | Go to step 7. |
| 7 | <p>Is the sensor (stacker bin level 2) connected properly?</p> | Replace the sensor (stacker bin level 2). See “Sensor (stacker bin level 2) removal” on page 4-34. | Replace the connection. |

| Step | Check | Yes | No |
|------|--|--|--------------------------------|
| 8 | <p>Check the sensor (stacker bin level encoder) for correct operation.</p> <p>Perform the Stacker bin level encod test.</p> <ol style="list-style-type: none"> 1. Enter Diagnostics mode. 2. Select FINISHER TESTS. 3. Select Sensor Tests. 4. Select Bin Level. 5. Select Stacker bin level encod. <p>Does the display on the operator panel change when the belt of the stacker bin lift motor assembly is moved by hand?</p> | Go to step 10. | Go to step 9. |
| 9 | <p>Is the sensor (stacker bin level encoder) connected properly?</p> | <p>Replace the sensor (stacker bin level encoder). See “Sensor (stacker bin level encoder) removal” on page 4-35.</p> | <p>Replace the connection.</p> |
| 10 | <p>Check the stacker bin lift motor assembly by blocking the lower hole in either of the sensor (stacker bin level). The stacker bin should lower slightly.</p> <p>Does the stacker bin lift motor assembly rotate normally?</p> | Go to step 12. | Go to step 11. |
| 11 | <p>Check the stacker bin lift motor assembly connection.</p> <p>Is the connector of the stacker bin lift motor assembly correctly connected to the finisher controller card assembly?</p> | <p>Replace the stacker bin lift motor assembly. See “Stacker bin lift motor assembly removal” on page 4-38.</p> | <p>Replace the connection.</p> |
| 12 | <p>Perform a test print.</p> <p>Does the error still occur?</p> | <p>Replace the finisher controller card assembly. See “Finisher controller card assembly removal” on page 4-118.</p> | <p>Problem solved.</p> |

982.00 Sensor (front tamper HP) on failure

| Step | Check | Yes | No |
|------|--|---------------|--|
| 1 | <p>Check the tamper mechanism by moving it with your fingers.</p> <p>Does the tamper mechanism operate smoothly?</p> | Go to step 2. | <p>Replace the media compiler unit assembly. See “Media compiler unit assembly removal” on page 4-69.</p> |

| Step | Check | Yes | No |
|------|---|--|-------------------------|
| 2 | <p>Check the sensor (front tamper HP) for correct operation.</p> <p>Perform the Front tamper HP test.</p> <ol style="list-style-type: none"> 1. Enter Diagnostics mode. 2. Select FINISHER TESTS. 3. Select Sensor Tests. 4. Select Media path2. 5. Select Front tamper HP. <p>Does the display on the operator panel change every time the sensing area of the sensor (front tamper HP) is blocked?</p> | Go to step 4. | Go to step 3. |
| 3 | Is the sensor (front tamper HP) connected properly? | Replace the sensor (front tamper HP). See “Sensor (front tamper HP) and sensor (rear tamper HP) removals” on page 4-72. | Replace the connection. |
| 4 | <p>Check the front tamper drive motor by opening the finisher front door assembly and then closing it.</p> <p>Does the front tamper drive motor rotate, and does the tamper move back and forth?</p> | Go to step 6. | Go to step 5. |
| 5 | <p>Check the compiler unit cable assembly connection.</p> <p>Are the connections of the compiler unit cable assembly correctly connected?</p> | Replace the media compiler unit assembly. See “Media compiler unit assembly removal” on page 4-69. | Replace the connection. |
| 6 | <p>Perform a test print.</p> <p>Does the error still occur?</p> | Replace the finisher controller card assembly. See “Finisher controller card assembly removal” on page 4-118. | Problem solved. |

982.01 Sensor (front tamper HP) off failure

| Step | Check | Yes | No |
|------|--|---------------|---|
| 1 | <p>Check the tamper mechanism by moving it with your fingers.</p> <p>Does the tamper mechanism operate smoothly?</p> | Go to step 2. | Replace the media compiler unit assembly. See “Media compiler unit assembly removal” on page 4-69. |

| Step | Check | Yes | No |
|------|---|--|-------------------------|
| 2 | <p>Check the sensor (front tamper HP) for correct operation.</p> <p>Perform the front tamper HP test.</p> <ol style="list-style-type: none"> 1. Enter Diagnostics mode. 2. Select FINISHER TESTS. 3. Select Sensor Tests. 4. Select Media path2. 5. Select Front tamper HP. <p>Does the display on the operator panel change every time the sensing area of the sensor (front tamper HP) is blocked?</p> | Go to step 4. | Go to step 3. |
| 3 | Is the sensor (front tamper HP) connected properly? | Replace the sensor (front tamper HP). See “Sensor (front tamper HP) and sensor (rear tamper HP) removals” on page 4-72. | Replace the connection. |
| 4 | <p>Check the front tamper drive motor by opening the finisher front door assembly and then closing it.</p> <p>Does the front tamper drive motor rotate, and does the tamper move back and forth?</p> | Go to step 6. | Go to step 5. |
| 5 | <p>Check the compiler unit cable assembly connection.</p> <p>Are the connections of the compiler unit cable assembly correctly connected?</p> | Replace the media compiler unit assembly. See “Media compiler unit assembly removal” on page 4-69. | Replace the connection. |
| 6 | <p>Perform a test print.</p> <p>Does the error still occur?</p> | Replace the finisher controller card assembly. See “Finisher controller card assembly removal” on page 4-118. | Problem solved. |

983.00 Sensor (rear tamper HP) on failure

| Step | Check | Yes | No |
|------|--|---------------|---|
| 1 | <p>Check the tamper mechanism by moving it with your fingers.</p> <p>Does the tamper mechanism operate smoothly?</p> | Go to step 2. | Replace the media compiler unit assembly. See “Media compiler unit assembly removal” on page 4-69. |

| Step | Check | Yes | No |
|------|---|--|-------------------------|
| 2 | <p>Check the sensor (rear tamper HP) for correct operation.</p> <p>Perform the Rear tamper HP test.</p> <ol style="list-style-type: none"> 1. Enter Diagnostics mode. 2. Select FINISHER TESTS. 3. Select Sensor Tests. 4. Select Media path2. 5. Select Rear tamper HP. <p>Does the display on the operator panel change every time the sensing area of the sensor (rear tamper HP) is blocked?</p> | Go to step 4. | Go to step 3. |
| 3 | Is the sensor (rear tamper HP) connected properly? | Replace the sensor (rear tamper HP). “Sensor (front tamper HP) and sensor (rear tamper HP) removals” on page 4-72. | Replace the connection. |
| 4 | <p>Check the rear tamper drive motor by opening the finisher front door assembly and then closing it.</p> <p>Does the rear tamper drive motor rotate, and does the tamper move back and forth?</p> | Go to step 6. | Go to step 5. |
| 5 | <p>Check the compiler unit cable assembly connection.</p> <p>Are the connections of the compiler unit cable assembly correctly connected?</p> | Replace the compiler unit assembly. | Replace the connection. |
| 6 | <p>Perform a test print.</p> <p>Does the error still occur?</p> | Replace the finisher controller card assembly. See “Finisher controller card assembly removal” on page 4-118. | Problem solved. |

983.01 Sensor (rear tamper HP) off failure

| Step | Check | Yes | No |
|------|--|---------------|---|
| 1 | <p>Check the tamper mechanism by moving it with your fingers.</p> <p>Does the tamper mechanism operate smoothly?</p> | Go to step 2. | Replace the media compiler unit assembly. See “Media compiler unit assembly removal” on page 4-69. |

| Step | Check | Yes | No |
|------|---|---|-------------------------|
| 2 | <p>Check the sensor (rear tamper HP) for correct operation.</p> <p>Perform the rear tamper HP test.</p> <ol style="list-style-type: none"> 1. Enter Diagnostics mode. 2. Select FINISHER TESTS. 3. Select Sensor Tests. 4. Select Media path2. 5. Select Rear tamper HP. <p>Does the display on the operator panel change every time the sensing area of the sensor (rear tamper HP) is blocked?</p> | Go to step 4. | Go to step 3. |
| 3 | Is the sensor (rear tamper HP) connected properly? | Replace the sensor (rear tamper HP). See “Sensor (front tamper HP) and sensor (rear tamper HP) removals” on page 4-72. | Replace the connection. |
| 4 | <p>Check the rear tamper drive motor by opening the finisher front door assembly and then closing it.</p> <p>Does the rear tamper drive motor rotate, and does the tamper move back and forth?</p> | Go to step 6. | Go to step 5. |
| 5 | <p>Check the compiler unit cable assembly connection.</p> <p>Are the connections of the compiler unit cable assembly correctly connected?</p> | Replace the media compiler unit assembly. See “Media compiler unit assembly removal” on page 4-69. | Replace the connection. |
| 6 | <p>Perform a test print.</p> <p>Does the error still occur?</p> | Replace the finisher controller card assembly. See “Finisher controller card assembly removal” on page 4-118. | Problem solved. |

984.00 Sensor (punch unit HP) on failure

| Step | Check | Yes | No |
|------|---|---------------|-------------------|
| 1 | <p>Check the punch unit by moving it with your fingers.</p> <p>Does the punch unit move smoothly?</p> | Go to step 2. | Remove obstacles. |

| Step | Check | Yes | No |
|------|---|--|-------------------------|
| 2 | <p>Check the sensor (punch unit HP) for correct operation. Perform the Punch unit HP test.</p> <ol style="list-style-type: none"> 1. Enter Diagnostics mode. 2. Select FINISHER TESTS. 3. Select Sensor Tests. 4. Select Punch and Staple. 5. Select Punch unit HP. <p>Does the display on the operator panel change every time the sensing area of the sensor (punch unit HP) is blocked?</p> | Go to step 4. | Go to step 3. |
| 3 | <p>Is the sensor (punch unit HP) and punch sensor cable assembly connected properly?</p> | <p>Replace the sensor (punch unit HP). See “Sensor (punch hole select), sensor (punch cam front), and sensor (punch unit HP) removal” on page 4-49.</p> | Replace the connection. |
| 4 | <p>Check the punch unit motor for correct operation. Perform the 2 punch test.</p> <ol style="list-style-type: none"> 1. Enter the Diagnostic mode. 2. Select FINISHER TESTS. 3. Select Hole Punch Test. 4. Select 2 Punch test. <p>Does the punch unit motor rotate normally and punch holes in the media?</p> | Go to step 6. | Go to step 5. |
| 5 | <p>Is the punch unit motor and punch drive cable assembly connected properly?</p> | <p>Replace the punch unit motor. See “Punch unit motor assembly removal” on page 4-47.</p> | Replace the connection. |
| 6 | <p>Perform a test print. Does the error still occur?</p> | <p>Replace the finisher controller card assembly. See “Finisher controller card assembly removal” on page 4-118.</p> | Problem solved. |

984.01 Sensor (punch unit HP) off failure

| Step | Check | Yes | No |
|------|--|---------------|----------------------|
| 1 | <p>Check the punch unit by moving it with your fingers. Does the punch unit move smoothly?</p> | Go to step 2. | Remove obstructions. |

| Step | Check | Yes | No |
|------|--|--|--------------------------------|
| 2 | <p>Check the sensor (punch unit HP) for correct operation. Perform the Punch unit HP test.</p> <ol style="list-style-type: none"> 1. Enter the Diagnostic mode. 2. Select FINISHER TESTS. 3. Select Sensor Tests. 4. Select Punch and Staple. 5. Select Punch unit HP. <p>Does the display on the operator panel change every time the sensing area of the sensor (punch unit HP) is blocked?</p> | Go to step 4. | Go to step 3. |
| 3 | <p>Is the sensor (punch unit HP) and punch sensor cable assembly connected properly?</p> | <p>Replace the sensor (punch unit HP). See “Sensor (punch hole select), sensor (punch cam front), and sensor (punch unit HP) removal” on page 4-49.</p> | <p>Replace the connection.</p> |
| 4 | <p>Check the punch unit motor for correct operation. Perform the 2 punch test.</p> <ol style="list-style-type: none"> 1. Enter the Diagnostic mode. 2. Select FINISHER TESTS. 3. Select Hole Punch Test. 4. Select 2 Punch test. <p>Does the punch unit motor rotate normally and punch holes in the media?</p> | Go to step 6. | Go to step 5. |
| 5 | <p>Is the punch unit motor and punch drive cable assembly connected properly?</p> | <p>Replace the punch unit motor. See “Punch unit motor assembly removal” on page 4-47.</p> | <p>Replace the connection.</p> |
| 6 | <p>Perform a test print. Does the error still occur?</p> | <p>Replace the finisher controller card assembly. See “Finisher controller card assembly removal” on page 4-118.</p> | <p>Problem solved.</p> |

985.00 Sensor (punch carriage shift HP) on failure

| Step | Check | Yes | No |
|------|--|---------------|-------------------|
| 1 | <p>Check the punch carriage for correct operation. Does the punch carriage move back and forth smoothly? Check this item by moving it with your fingers.</p> | Go to step 2. | Remove obstacles. |

| Step | Check | Yes | No |
|------|--|--|-------------------------|
| 2 | <p>Check the sensor (punch carriage shift HP) for correct operation.</p> <p>Perform the Punch carriage shift HP test.</p> <ol style="list-style-type: none"> 1. Enter the Diagnostic mode. 2. Select FINISHER TESTS. 3. Select Sensor Test. 4. Select Punch and Staple. 5. Select Punch carriage shift HP. <p>Is the above sensor connected properly?</p> | Go to step 4. | Go to step 3. |
| 3 | <p>Check the sensor (punch carriage shift HP) connection.</p> <p>Are the connections of the punch sensor cable assembly correctly connected?</p> | Replace the sensor (punch carriage shift HP). See “Sensor (punch carriage shift HP) removal” on page 4-51 . | Replace the connection. |
| 4 | <p>Check the punch carriage shift motor assembly by opening and then closing the finisher front door. The punch carriage should move slightly.</p> <p>Does the punch carriage shift motor assembly rotate, and does the punch shift carriage move back and forth?</p> | Go to step 6. | Go to step 9. |
| 5 | <p>Is the punch carriage shift motor assembly connected properly?</p> | Replace the punch carriage shift motor assembly. See “Punch carriage shift motor assembly removal” on page 4-43 . | Replace the connection. |
| 6 | <p>Perform a test print.</p> <p>Does the error still occur.</p> | Replace the printer engine card assembly. Refer to the <i>Printer Service Manual</i> . | Problem solved. |

985.01 Sensor (punch carriage shift HP) off failure

| Step | Check | Yes | No |
|------|--|---------------|----------------------|
| 1 | <p>Check the punch carriage by moving it with your fingers.</p> <p>Does the punch carriage move back and forth smoothly?</p> | Go to step 2. | Remove obstructions. |

| Step | Check | Yes | No |
|------|--|---|-------------------------|
| 2 | <p>Check the sensor (punch carriage shift HP) for correct operation.</p> <p>Perform the Punch carriage shift HP test.</p> <ol style="list-style-type: none"> 1. Enter the Diagnostic mode. 2. Select FINISHER TESTS. 3. Select Sensor Test. 4. Select Punch and Staple. 5. Select Punch carriage shift HP. <p>Is the above sensor connected properly?</p> | Go to step 4. | Go to step 3. |
| 3 | <p>Check the sensor (punch carriage shift HP) connection.</p> <p>Are the connections of the punch sensor cable assembly properly connected?</p> | Replace the sensor (punch carriage shift HP). See “Sensor (punch carriage shift HP) removal” on page 4-51. | Replace the connection. |
| 4 | <p>Check the punch carriage shift motor assembly by opening and closing the finisher front door. The punch carriage should move slightly.</p> <p>Does the punch carriage shift motor assembly rotate, and does the punch shift carriage move back and forth?</p> | Go to step 6. | Go to step 5. |
| 5 | <p>Is the punch carriage shift motor assembly connected properly?</p> | Replace the punch carriage shift motor assembly. See “Punch carriage shift motor assembly removal” on page 4-43. | Replace the connection. |
| 6 | <p>Perform a test print.</p> <p>Does the error still occur.</p> | Replace the printer engine card assembly. Refer to the <i>Printer Service Manual</i> . | Problem solved. |

986.00 Sensor (media eject clamp HP) on failure

| Step | Check | Yes | No |
|------|--|---------------|-------------------|
| 1 | <p>Check the media eject clamp by opening the finisher front door assembly and then closing it.</p> <p>Does the eject clamp mechanism move smoothly?</p> | Go to step 2. | Remove obstacles. |

| Step | Check | Yes | No |
|------|--|---|-------------------------|
| 2 | <p>Check the sensor (media eject clamp HP) for correct operation.</p> <p>Perform the Eject clamp HP test.</p> <ol style="list-style-type: none"> 1. Enter the Diagnostic mode. 2. Select FINISHER TESTS. 3. Select Sensor Test. 4. Select Media Path 2. 5. Select Eject clamp HP. <p>Does the display on the operator panel change every time the sensing area of the sensor (media eject clamp HP) is blocked?</p> | Go to step 4. | Go to step 3. |
| 3 | <p>Check the sensor (media eject clamp HP) connection.</p> <p>Is the above sensor connected properly?</p> | <p>Replace the sensor (media eject clamp HP). See "Sensor (media eject clamp HP) removal" on page 4-67.</p> | Replace the connection. |
| 4 | <p>Check the media eject clamp motor by opening the finisher front door assembly and then closing it.</p> <p>Does the eject clamp motor rotate normally?</p> | Go to step 6. | Go to step 5. |
| 5 | <p>Is the media eject clamp motor connected properly?</p> | <p>Replace the media eject clamp motor. See "Media eject clamp motor assembly removal" on page 4-66.</p> | Replace the connection. |
| 6 | <p>Perform a test print.</p> <p>Does the error still occur?</p> | <p>Replace the finisher controller card assembly. See "Finisher controller card assembly removal" on page 4-118.</p> | Problem solved. |

986.01 Sensor (media eject clamp HP) off failure

| Step | Check | Yes | No |
|------|--|---------------|-------------------|
| 1 | <p>Check the media eject clamp by opening the finisher front door assembly and then closing it.</p> <p>Does the eject clamp mechanism move smoothly?</p> | Go to step 2. | Remove obstacles. |

| Step | Check | Yes | No |
|------|--|---|-------------------------|
| 2 | <p>Check the sensor (media eject clamp HP) for correct operation.</p> <p>Perform the Eject clamp HP test.</p> <ol style="list-style-type: none"> 1. Enter Diagnostics. 2. Select FINISHER TESTS. 3. Select Sensor Tests. 4. Select Media Path2. 5. Select Eject clamp HP. <p>Does the display on the operator panel change every time the sensing area of the sensor (media eject clamp HP) is blocked?</p> | Go to step 4. | Go to step 3. |
| 3 | <p>Is the sensor (media eject clamp HP) connected properly?</p> | <p>Replace the sensor (media eject clamp HP). See "Sensor (media eject clamp HP) removal" on page 4-67.</p> | Replace the connection. |
| 4 | <p>Check the media eject clamp by opening the finisher front door assembly and then closing it.</p> <p>Does the eject clamp motor rotate normally?</p> | Go to step 6. | Go to step 5. |
| 5 | <p>Is the media eject clamp motor connected properly?</p> | <p>Replace the media eject clamp motor. See "Media eject clamp motor assembly removal" on page 4-66.</p> | Replace the connection. |
| 6 | <p>Perform a test print.</p> <p>Does the error still occur?</p> | <p>Replace the finisher controller card assembly. See "Finisher controller card assembly removal" on page 4-118.</p> | Problem solved. |

987.00 Sensor (media eject shaft HP) on failure

| Step | Check | Yes | No |
|------|---|---------------|----------------------|
| 1 | <p>Check the media eject shaft assembly by moving it with your fingers.</p> <p>Does the media eject shaft assembly mechanism move smoothly?</p> | Go to step 2. | Remove obstructions. |

| Step | Check | Yes | No |
|------|--|--|-------------------------|
| 2 | <p>Check the sensor (media eject shaft HP) for correct operation.</p> <p>Perform the Media eject shaft HP test.</p> <ol style="list-style-type: none"> 1. Enter Diagnostics mode. 2. Select FINISHER TESTS. 3. Select Sensor Tests. 4. Select Media Path2. 5. Select Media eject shaft HP. <p>Does the display on the operator panel change every time the sensing area of the sensor (media eject shaft HP)?</p> | Go to step 4. | Go to step 3. |
| 3 | <p>Check the sensor (media eject shaft HP) connection.</p> <p>Are the connections of the main sensor cable assembly correctly connected?</p> | Replace the sensor (media eject shaft HP). See " Sensor (media eject shaft HP) removal " on page 4-79. | Replace the connection. |
| 4 | <p>Check the media eject motor assembly by opening the finisher front door assembly and then closing it.</p> <p>Does the media eject motor assembly rotate normally?</p> | Go to step 6. | Go to step 5. |
| 5 | <p>Is the media eject motor assembly connected properly?</p> | Replace the media eject motor assembly. See " Media eject motor assembly removal " on page 4-78. | Replace the connection. |
| 6 | <p>Check the media eject clutch assembly by opening the finisher front door assembly and then closing it. The three clamp paddles should rotate.</p> <p>Does the media eject clutch assembly operate?</p> | Go to step 8. | Go to step 7. |
| 7 | <p>Check the media eject clutch assembly connection.</p> <p>Is the above component connected properly?</p> | Replace the media eject clutch assembly. See " Media eject clutch removal " on page 4-77. | Replace the connection. |
| 8 | <p>Perform a test print.</p> <p>Does the error still occur?</p> | Replace the finisher controller card assembly. See " Finisher controller card assembly removal " on page 4-118. | Problem solved. |

987.01 Sensor (media eject shaft HP) off failure

| Step | Check | Yes | No |
|------|--|--|-------------------------|
| 1 | Check the media eject shaft assembly by moving it with your fingers. Does the media eject shaft assembly mechanism move smoothly? | Go to step 2. | Remove obstructions. |
| 2 | Check the sensor (media eject shaft HP) for correct operation. Perform the Media eject shaft HP test. 1. Enter Diagnostics mode. 2. Select FINISHER TESTS . 3. Select Sensor Tests . 4. Select Media Path2 . 5. Select Media eject shaft HP . Does the display on the operator panel change every time the sensing area of the sensor (media eject shaft HP)? | Go to step 4. | Go to step 3. |
| 3 | Check the sensor (media eject shaft HP) connection. Are the connections of the main sensor cable assembly correctly connected? | Replace the sensor (media eject shaft HP). See " Sensor (media eject shaft HP) removal " on page 4-79. | Replace the connection. |
| 4 | Check the for correct operation. Check the media eject motor assembly by opening the finisher front door assembly and then closing it. Does the media eject motor assembly rotate normally? | Go to step 6. | Go to step 5. |
| 5 | Is the media eject motor assembly connected properly? | Replace the media eject motor assembly. See " Media eject motor assembly removal " on page 4-78. | Replace the connection. |
| 6 | Check the media eject clutch assembly by opening the finisher front door assembly and then closing it. The three clamp paddles should rotate. Does the media eject clutch assembly operate? | Go to step 8. | Go to step 7. |
| 7 | Is the media eject clutch assembly connected properly? | Replace the media eject clutch assembly. See " Media eject clutch removal " on page 4-77. | Replace the connection. |

| Step | Check | Yes | No |
|------|--|--|-----------------|
| 8 | Perform a test print. Does the error still occur? | Replace the finisher controller card assembly. See “Finisher controller card assembly removal” on page 4-118. | Problem solved. |

988.00 Sensor (punch unit side reg) on failure

Note: This procedure pertains to sensor punch unit reg1 and reg2.

| Step | Check | Yes | No |
|------|---|--|-------------------------|
| 1 | Check the punch carriage by moving it with your fingers. Does the punch carriage move back and forth smoothly? | Go to step 2. | Remove obstructions. |
| 2 | Check the sensor (punch unit side reg1) for correct operation. Perform the Punch side reg1 test. 1. Enter Diagnostics mode. 2. Select FINISHER TESTS . 3. Select Sensor Tests . 4. Select Punch and Staple . 5. Select Punch side reg1 . Does the display on the operator panel change every time a piece of white media is placed over the sensing area of the sensor (punch unit side reg1)? | Go to step 3. | Go to step 4. |
| 3 | Check the sensor (punch unit side reg2) for correct operation. Perform the Punch side reg2 test. 1. Enter Diagnostics mode. 2. Select FINISHER TESTS . 3. Select Sensor Tests . 4. Select Punch and Staple . 5. Select Punch side reg2 . Does the display on the operator panel change every time a piece of white media is placed over the sensing area of the sensor (punch unit side reg2)? | Go to step 5. | Go to step 4. |
| 4 | Check the appropriate sensor (punch unit side reg) connection. Is the above sensor connected properly? | Replace the appropriate sensor (punch unit side reg). See “Sensor (punch unit side registration pair) with bracket removal” on page 4-44. | Replace the connection. |

| Step | Check | Yes | No |
|------|---|---|-------------------------|
| 5 | Check the punch carriage shift motor assembly by moving the punch carriage forward, then opening the finisher front door; the punch carriage should move slightly. Does the punch carriage shift motor assembly rotate, and does the punch shift carriage move back and forth? | Go to step 7. | Go to step 6. |
| 6 | Is the punch carriage shift motor assembly connected properly? | Replace the punch carriage shift motor assembly. See "Punch carriage shift motor assembly removal" on page 4-43. | Replace the connection. |
| 7 | Perform a test print. Does the error still occur? | Replace the printer engine card assembly. Refer to the <i>Printer Service Manual</i> . | Problem solved. |

988.01 Sensor (punch unit side reg) off failure

Note: This procedure pertains to sensor punch unit reg1 and reg2.

| Step | Check | Yes | No |
|------|---|---------------|----------------------|
| 1 | Check the punch carriage by moving it with your fingers. Does the punch carriage move back and forth smoothly? | Go to step 2. | Remove obstructions. |
| 2 | Check the sensor (punch unit side reg1) for correct operation. Perform the Punch side reg1 test. 1. Enter Diagnostics mode. 2. Select FINISHER TESTS . 3. Select Sensor Tests . 4. Select Punch and Staple . 5. Select Punch side reg1 . Does the display on the operator panel change every time a piece of white media is placed over the sensing area of the sensor (punch unit side reg1)? | Go to step 3. | Go to step 4. |

| Step | Check | Yes | No |
|------|---|---|-------------------------|
| 3 | <p>Check the sensor (punch unit side reg2) for correct operation.</p> <p>Perform the Punch side reg2 test.</p> <ol style="list-style-type: none"> 1. Enter Diagnostics mode. 2. Select FINISHER TESTS. 3. Select Sensor Tests. 4. Select Punch and Staple. 5. Select Punch side reg2. <p>Does the display on the operator panel change every time a piece of white media is placed over the sensing area of the sensor (punch unit side reg2)?</p> | Go to step 5. | Go to step 4. |
| 4 | <p>Check the appropriate sensor (punch unit side reg) connection.</p> <p>Is the above sensor connected properly?</p> | <p>Replace the appropriate sensor (punch unit side reg). See “Sensor (punch unit side registration pair) with bracket removal” on page 4-44.</p> | Replace the connection. |
| 5 | <p>Check the punch carriage shift motor assembly by moving the punch carriage forward, then opening the finisher front door; the punch carriage should move slightly.</p> <p>Does the punch carriage shift motor assembly rotate, and does the punch shift carriage move back and forth?</p> | Go to step 7. | Go to step 6. |
| 6 | Is the punch carriage shift motor assembly connected properly? | <p>Replace the punch carriage shift motor assembly. See “Punch carriage shift motor assembly removal” on page 4-43.</p> | Replace the connection. |
| 7 | <p>Perform a test print.</p> <p>Does the error still occur?</p> | <p>Replace the printer engine card assembly. Refer to the <i>Printer Service Manual</i>.</p> | Problem solved. |

989.00 Stapler unit failure

| Step | Check | Yes | No |
|------|--|--|--------------------------------|
| 1 | <p>Check the stapler unit assembly for correct operation.</p> <p>Perform the Staple test.</p> <ol style="list-style-type: none"> 1. Enter Diagnostics mode. 2. Select FINISHER TESTS. 3. Select Staple Test. <p>Does the motor in the stapler unit assembly rotate normally and staple the media?</p> | <p>Check for staples and staple jam. Problem resolved.</p> | <p>Go to step 2.</p> |
| 2 | <p>Is the stapler unit assembly connected properly?</p> | <p>Replace the stapler unit assembly. See “Stapler unit assembly removal” on page 4-56.</p> | <p>Replace the connection.</p> |
| 3 | <p>Perform a test print stapled document.</p> <p>Does the error still occur?</p> | <p>Replace the printer engine card assembly. Refer to the <i>Printer Service Manual</i>.</p> | <p>Problem solved.</p> |

990.00 Sensor (stapler carriage HP) on failure

| Step | Check | Yes | No |
|------|--|--|--------------------------------|
| 1 | <p>Check the stapler by moving it with your fingers.</p> <p>Does the Stapler carriage move smoothly?</p> | <p>Go to step 2.</p> | <p>Remove obstructions.</p> |
| 2 | <p>Check the sensor (stapler carriage HP) for correct operation.</p> <p>Perform the Stapler carriage shift HP test.</p> <ol style="list-style-type: none"> 1. Enter Diagnostics mode. 2. Select FINISHER TESTS. 3. Select Sensor Tests. 4. Select Punch and Staple. 5. Select Stapler carriage shift HP. <p>Does the display on the operator panel change every time the sensing area of the sensor (stapler carriage HP) is placed to the interrupt flag of the stapler rack gear by moving the stapler carriage by hand</p> | <p>Go to step 4.</p> | <p>Go to step 3.</p> |
| 3 | <p>Is the sensor (stapler carriage HP) connected properly?</p> | <p>Replace the sensor (stapler carriage HP). See “Sensor (stapler carriage HP) removal” on page 4-58.</p> | <p>Replace the connection.</p> |

| Step | Check | Yes | No |
|------|---|--|------------------------|
| 4 | Check the stapler carriage motor assembly by opening the finisher front door assembly then pushing the stapler carriage towards the back. Then closing the finisher front door assembly, the stapler carriage should move. Does the stapler carriage motor assembly rotate normally? | Go to step 6. | Go to step 5. |
| 5 | Is the stapler carriage motor assembly connected properly? | Replace the stapler carriage motor assembly. | Replace the connection |
| 6 | Perform a test print stapled document. Does the error still occur? | Replace the printer engine card assembly. Refer to the <i>Printer Service Manual</i> . | Problem solved. |

990.01 Sensor (stapler carriage HP) off failure

| Step | Check | Yes | No |
|------|---|---|-------------------------|
| 1 | Check the stapler by moving it with your fingers. Does the Stapler carriage move smoothly? | Go to step 2. | Remove obstructions. |
| 2 | Check the sensor (stapler carriage HP) for correct operation. Perform the Stapler carriage shift HP test. 1. Enter Diagnostics mode. 2. Select FINISHER TESTS . 3. Select Sensor Tests . 4. Select Punch and Staple . 5. Select Stapler carriage shift HP . Does the display on the operator panel change every time the sensing area of the sensor (stapler carriage HP) is placed to the interrupt flag of the stapler rack gear by moving the stapler carriage by hand? | Go to step 4. | Go to step 3. |
| 3 | Is the sensor (stapler carriage HP) connected properly? | Replace the sensor (stapler carriage HP). See " Sensor (stapler carriage HP) removal " on page 4-58. | Replace the connection. |
| 4 | Check the stapler carriage motor assembly by opening the finisher front door assembly then pushing the stapler carriage towards the back. Then closing the finisher front door assembly, the stapler carriage should move. Does the stapler carriage motor assembly rotate normally? | Go to step 6. | Go to step 5. |
| 5 | Is the stapler carriage motor assembly connected properly? | Replace the stapler carriage motor assembly. | Replace the connection. |

| Step | Check | Yes | No |
|------|---|--|-----------------|
| 6 | Perform a test print stapled document. Does the error still occur? | Replace the printer engine card assembly. Refer to the <i>Printer Service Manual</i> . | Problem solved. |

995.00 Finisher NVRAM R/W failure

| Step | Check | Yes | No |
|------|--|--|-------------------|
| 1 | Turn the finisher off and on several times. Does the error still occur when the power is on? | Go to step 2. | Problem solved. |
| 2 | Checking the finisher controller card assembly for connection. Are the connections of the finisher controller card assembly properly connected? | Replace the finisher controller card assembly. “Finisher controller card assembly removal” on page 4-118. | Problem resolved. |

996.00 Finisher type failure

| Step | Check | Yes | No |
|------|--|--|-------------------------|
| 1 | Check the printer and finisher installation. Is the finisher installed to the printer correctly? | Go to step 2. | Reinstall the finisher. |
| 2 | Turn the power on and off. Does the error still occur when the power is back on? | Go to step 3. | Problem solved. |
| 3 | Check the finisher controller card assembly connection. Are the connections of the finisher controller card assembly correctly connected? | Replace the finisher controller card assembly. See “Finisher controller card assembly removal” on page 4-118. | Replace the connection. |

999.00 Finisher engine/RIP functional failure

| Step | Check | Yes | No |
|------|---|---|-----------------|
| 1 | Turn the printer off and on several times. Does the error still occur when the power is on? | Go to step 2. | Problem solved. |
| 2 | Check the finisher controller card assembly connection. Are the connections of the finisher controller card assembly properly connected? | Replace the finisher controller card assembly. See “Finisher controller card assembly removal” on page A-118. | Problem solved. |

Bridge unit top cover open

| Step | Check | Yes | No |
|------|--|---|--|
| 1 | Open and close the bridge unit top cover assembly on the bridge unit assembly. Does it open or close smoothly? | Go to step 2. | Check the bridge unit top cover assembly for installation, correct deformations, or replace it. see “Bridge unit top cover assembly removal” on page 4-7. |
| 2 | Check the bridge unit top cover assembly on the bridge unit assembly for shape and operation. Is the actuator of the bridge unit top cover assembly that enters the sensor (bridge unit top cover interlock) damaged? | Replace the bridge unit top cover assembly. See “Bridge unit top cover assembly removal” on page 4-7. | Go to step 3. |
| 3 | Check the sensor (bridge unit top cover interlock) installation. Is the sensor (bridge unit top cover interlock) installed correctly? | Go to step 4. | Reinstall the sensor (bridge unit top cover interlock). See “Sensor (bridge unit top cover interlock) removal” on page 4-15. |

| Step | Check | Yes | No |
|------|---|---|-------------------------|
| 4 | <p>Check the sensor (bridge unit top cover interlock) for correct operation.</p> <p>Perform the Door F bridge top fin front test.</p> <ol style="list-style-type: none"> 1. Enter Diagnostics mode. 2. Select FINISHER TESTS. 3. Select Sensor Tests. 4. Select Cover and Door. 5. Select Door F bridge top. <p>Does the display on the operator panel change every time the detection point of the sensor (bridge unit top cover interlock) is blocked?</p> | Go to step 6. | Go to step 5. |
| 5 | Is the sensor (bridge unit top cover interlock) connected properly? | Replace the sensor (bridge unit top cover interlock). See “Sensor (bridge unit top cover interlock) removal” on page 4-15. | Replace the connection. |
| 6 | Does the error still occur when the power is turned on? | Go to step 7. | Problem solved. |
| 7 | <p>Replace the finisher controller card assembly. See “Finisher controller card assembly removal” on page 4-118.</p> <p>Does the error still occur when the power is turned on?</p> | Replace the printer engine card assembly. Refer to the <i>Printer Service Manual</i> . | Problem solved. |

Finisher front door open

| Step | Check | Yes | No |
|------|--|---------------|---|
| 1 | <p>Open and close the finisher front door assembly.</p> <p>Does it open or close smoothly?</p> | Go to step 2. | Check the finisher front door assembly for installation, correct deformations, or replace it. See “Finisher front door assembly removal” on page 4-27. |
| 2 | <p>Check the switch (finisher front door interlock) installation</p> <p>Is the switch (finisher front door interlock) installed correctly?</p> | Go to step 3. | Reinstall the switch (finisher front door interlock). See “Switch (finisher front door interlock) removal” on page 4-26. |

| Step | Check | Yes | No |
|------|---|--|--------------------------------|
| 3 | <p>Check the switch (finisher front door interlock) for correct operation.</p> <p>Perform the Door G fin front test.</p> <ol style="list-style-type: none"> 1. Enter Diagnostics mode. 2. Select FINISHER TESTS. 3. Select Sensor Tests. 4. Select Cover and Door. 5. Select Door G fin front. <p>Does the display on the operator panel change every time the detection point of the switch (finisher front door interlock) is pressed by the tip of the screwdriver?</p> | Go to step 5. | Go to step 4. |
| 4 | <p>Is the switch (finisher front door interlock) connected properly?</p> | <p>Replace the switch (finisher front door interlock). See “Switch (finisher front door interlock) removal” on page 4-26.</p> | <p>Replace the connection.</p> |
| 5 | <p>Does the error still occur when the power is turned off and back on?</p> | Go to step 6. | Problem solved. |
| 6 | <p>Replace the finisher controller card assembly.</p> <p>Does the error still occur when the power is turned off and back on?</p> | <p>Replace the printer engine card assembly. Refer to the <i>Printer Service Manual</i>.</p> | Problem solved. |

Finisher eject cover open

| Step | Check | Yes | No |
|------|---|---------------|---|
| 1 | <p>Check the switch (eject cover interlock) installation.</p> <p>Is the switch (eject cover interlock) installed correctly?</p> | Go to step 2. | Reinstall the switch (media eject cover). |
| 2 | <p>Check the operation of the switch (eject cover interlock).</p> <p>Perform the Surface H fin eject test.</p> <ol style="list-style-type: none"> 1. Enter Diagnostics mode. 2. Select FINISHER TESTS. 3. Select Sensor Tests. 4. Select Cover and Door. 5. Select Surface H fin eject. <p>Does the display on the operator panel change every time the actuator of the switch is activated?</p> | Go to step 4. | Go to step 3. |

| Step | Check | Yes | No |
|------|---|--|-------------------------|
| 3 | Is the switch (media cover interlock) connected properly? | Replace the switch (eject cover interlock). See “Switch (eject cover interlock) removal” on page 4-68. | Replace the connection. |
| 4 | Perform a test print. Does the error still occur? | Replace the finisher controller card assembly. See “Finisher controller card assembly removal” on page 4-118. | Problem solved. |

Finisher upper media bin full

| Step | Check | Yes | No |
|------|--|--|-------------------------|
| 1 | Check the sensor (upper media bin full) for correct operation. Perform the Fin upper bin full test. 1. Enter Diagnostics mode. 2. Select FINISHER TESTS . 3. Select Sensor Tests . 4. Select Bin Level . 5. Select Fin upper bin full . Does the display of the operator panel change every time a piece of white media is placed over the sensing area of the sensor (upper media bin full)? | Replace the finisher controller card assembly. See “Finisher controller card assembly removal” on page 4-118. | Go to step 2. |
| 2 | Is the sensor (upper media bin full) connected properly? | Replace the sensor (upper media bin full). See “Sensor (upper media bin full) removal” on page 4-108. | Replace the connection. |
| 3 | Perform a test print. Does the error still occur? | Replace the finisher controller card assembly. See “Finisher controller card assembly removal” on page 4-118. | Problem solved. |

No punch waste box.

| Step | Check | Yes | No |
|------|--|--|---|
| 1 | Check the sensor (punch waste box present) for correct operation. Is the sensor installed properly? | Go to step 2. | Reinstall the sensor (punch waste box set). See “Sensor (punch waste box set) removal” on page 4-52. |
| 2 | Check the sensor (punch waste box set). Perform Punch box set test. 1. Enter Diagnostics mode. 2. Select FINISHER TESTS . 3. Select Sensor Tests . 4. Select Punch and Staple . 5. Select Punch box set . Does the display on the operator panel change every time the sensing area of the sensor (punch waste box set) is blocked? | Go to step 4. | Go to step 3. |
| 3 | Is the sensor (punch waste box set properly connected? | Replace the sensor (punch waste box set). See “Sensor (punch waste box set) removal” on page 4-52. | Replace the connection. |
| 4 | Perform a test print. Does the error still occur? | Replace the bridge interface card assembly. See “Bridge unit interface card assembly removal” on page 4-117. Go to step 5. | Problem solved. |
| 5 | Perform a test print. Does the error still occur? | Replace the finisher controller card assembly. See “Finisher controller card assembly removal” on page 4-118. | Problem solved. |

Punch waste box full

| Step | Check | Yes | No |
|------|--|--|---|
| 1 | Check the sensor (punch waste box full) for correct installation. Is the sensor installed properly? | Go to step 2. | Reinstall the sensor (punch waste box full). See “Sensor (punch waste box full) removal” on page 4-53. |
| 2 | Check the sensor (punch waste box full). Perform the Punch waste box full test. 1. Enter Diagnostics mode. 2. Select FINISHER TESTS . 3. Select Sensor Tests . 4. Select Punch and Staple . 5. Select Punch waste box full . Does the display on the operator panel change every time the sensing area of the sensor (punch waste box full) is blocked? | Go to step 4. | Go to step 3. |
| 3 | Perform a test print. Does the error still occur? | Replace the sensor (punch waste box full). See “Sensor (punch waste box full) removal” on page 4-53. | Replace the connection. |
| 4 | Perform a test print. Does the error still occur? | Replace the finisher controller card assembly. See “Finisher controller card assembly removal” on page 4-118. | Problem solved. |

Stacker media bin full (mix size)

| Step | Check | Yes | No |
|------|--|--------------------------|---------------|
| 1 | Check the stacker bin for obstructions. Are there any obstructions on the upper and lower parts of the stacker bin? | Remove the obstructions. | Go to step 2. |

| Step | Check | Yes | No |
|------|--|---|-----------------------------------|
| 2 | <p>Check the sensor (stacker bin level 1) for correct operation.</p> <p>Perform the Stacker bin level1 test.</p> <ol style="list-style-type: none"> 1. Enter Diagnostics mode. 2. Select FINISHER TESTS. 3. Select Sensor Tests. 4. Select Bin Level. 5. Select Stacker bin level1. <p>Does the display on the operator panel change every time the sensing area of the sensor (stacker bin level 1) is blocked by a multi page document or your finger?</p> | Go to step 4. | Go to step 3. |
| 3 | Is the sensor (stacker bin level 1) connected properly? | Replace the sensor (stacker bin level 1). See “Sensor (stacker bin level 1) removal” on page 4-34. | Replace the connection. |
| 4 | <p>Check the sensor (stacker bin level 2) for correct operation.</p> <p>Perform the Stacker bin level2 test.</p> <ol style="list-style-type: none"> 1. Enter Diagnostics mode. 2. Select FINISHER TESTS. 3. Select Sensor Tests. 4. Select Bin Level. 5. Select Stacker bin level2. <p>Does the display on the operator panel change every time the sensing area of the sensor (stacker bin level rear) is blocked by a multi page document or your finger?</p> | Go to step 6. | Go to step 5. |
| 5 | Is the sensor (stacker bin level 2) connected properly? | Replace the sensor (stacker bin level 2). See “Sensor (stacker bin level 2) removal” on page 4-34. | Replace the connection. |
| 6 | <p>Check the encoder of the sensor (stacker bin level encoder) installation.</p> <p>Is the encoder installed correctly?</p> <p>Does it enter the detection point of the sensor (stacker bin level encoder)?</p> | Go to step 7. | After reinstalling, go to step 7. |

| Step | Check | Yes | No |
|------|---|--|-------------------------|
| 7 | <p>Check the sensor (stacker bin level encoder) for correct operation.</p> <p>Perform the Stacker level encod test.</p> <ol style="list-style-type: none"> 1. Enter Diagnostics mode. 2. Select FINISHER TESTS. 3. Select Sensor Tests. 4. Select Bin Level. 5. Select Stacker level encod. <p>Does the operator panel display change when the belt of the stacker bin lift motor assembly is moved by hand?</p> | Go to step 9. | Go to step 8. |
| 8 | <p>Is the sensor (stacker bin level encoder) connected properly?</p> | <p>Replace the sensor (stacker bin level encoder). See “Sensor (stacker bin level encoder) removal” on page 4-35.</p> | Replace the connection. |
| 9 | <p>Check the stacker bin lift motor assembly by blocking the lower hole in either of the sensor (stacker bin level). The stacker bin should lower slightly.</p> <p>Does the stacker bin lift motor assembly rotate normally?</p> | <p>Replace the finisher controller card assembly. See “Finisher controller card assembly removal” on page 4-118.</p> | Go to step 10. |
| 10 | <p>Is the stacker bin lift motor assembly connected properly?</p> | <p>Replace the stacker bin lift motor assembly. See “Stacker bin lift motor assembly removal” on page 4-38.</p> | Replace the connection. |
| 11 | <p>Perform a test print.</p> <p>Does the error still occur?</p> | <p>Replace the finisher controller card assembly. See “Finisher controller card assembly removal” on page 4-118.</p> | Problem solved. |

Stacker media bin full (no mix)

| Step | Check | Yes | No |
|------|---|--------------------------|---------------|
| 1 | <p>Check the stacker bin for obstructions.</p> <p>Are there any obstructions on the upper and lower parts of the stacker bin?</p> | Remove the obstructions. | Go to step 2. |

| Step | Check | Yes | No |
|------|---|---|-----------------------------------|
| 2 | <p>Check the sensor (stacker bin level 1) for correct operation.</p> <p>Perform the Stacker bin level1 test.</p> <ol style="list-style-type: none"> 1. Enter Diagnostics mode. 2. Select FINISHER TESTS. 3. Select Sensor Tests. 4. Select Bin Level. 5. Select Stacker bin level1. <p>Does the display on the operator panel change every time the sensing area of the sensor (stacker bin level 1) is blocked by a multi page document or your finger?</p> | Go to step 4. | Go to step 3. |
| 3 | Is the sensor (stacker bin level 1) installed correctly? | Replace the sensor (stacker bin level 1). See “Sensor (stacker bin level 1) removal” on page 4-34. | Replace the connection. |
| 4 | <p>Check the sensor (stacker bin level 2) for correct operation.</p> <p>Perform the Stacker bin level2 test.</p> <ol style="list-style-type: none"> 1. Select Diagnostics mode. 2. Select FINISHER TESTS,. 3. Select Sensor Tests. 4. Select Bin Level. 5. Select Stacker bin level2. <p>Does the display on the operator panel change every time the sensing area of the sensor (stacker bin level rear) is blocked by blocked by a multi page document or your finger?</p> | Go to step 5. | Go to step 6. |
| 5 | Is the sensor (stacker bin level 2) connected properly? | Replace the sensor (stacker bin level 2). See “Sensor (stacker bin level 2) removal” on page 4-34. | Replace the connection. |
| 6 | <p>Check the encoder of the sensor (stacker bin level encoder) installation.</p> <p>Is the encoder installed correctly?</p> <p>Does it enter the detection point of the sensor (stacker bin level encoder)?</p> | Go to step 7. | After reinstalling, go to step 7. |

| Step | Check | Yes | No |
|------|---|--|-------------------------|
| 7 | <p>Check the sensor (stacker bin level encoder) for correct operation.</p> <p>Perform the Stacker level encod test.</p> <ol style="list-style-type: none"> 1. Enter Diagnostics mode. 2. Select FINISHER TESTS. 3. Select Sensor Tests. 4. Select Bin Level. 5. Select Stacker level encod. <p>Does the operator panel display change when the belt of the stacker bin lift motor assembly is moved by hand?</p> | Go to step 9. | Go to step 8. |
| 8 | <p>Is the sensor (stacker bin level encoder) connected properly?</p> | <p>Replace the sensor (stacker bin level encoder). See “Sensor (stacker bin level encoder) removal” on page 4-35.</p> | Replace the connection. |
| 9 | <p>Check the stacker bin lift motor assembly for correct operation.</p> <p>Check the above motor by blocking the lower hole in either of the sensors (stacker bin level). The stacker bin should lower slightly.</p> <p>Does the stacker bin lift motor assembly rotate normally?</p> | Go to step 11. | Go to step 10. |
| 10 | <p>Is the stacker bin lift motor assembly connected properly?</p> | <p>Replace the stacker bin lift motor assembly. See “Stacker bin lift motor assembly removal” on page 4-38.</p> | Replace the connection. |
| 11 | <p>Perform a test print.</p> <p>Does the error still occur?</p> | <p>Replace the finisher controller card assembly. See “Finisher controller card assembly removal” on page 4-118.</p> | Problem solved. |

Stacker lower safety failure

| Step | Check | Yes | No |
|------|--|------------------------|---------------|
| 1 | <p>Check the vertical transport mechanism of the stacker bin for obstructions and deformation.</p> <p>Are there any obstructions in the vertical transport mechanism of the stacker bin?</p> | Remove obstructions. | Go to step 2. |
| 2 | <p>Is there any deformation in the vertical transport mechanism of the stacker bin?</p> | Replace deformed part. | Go to step 3. |

| Step | Check | Yes | No |
|------|--|---|-------------------------|
| 3 | <p>Check the sensor (stacker bin level 1) for correct operation.</p> <p>Perform the Stacker bin level1 test.</p> <ol style="list-style-type: none"> 1. Enter Diagnostics mode. 2. Select FINISHER TESTS. 3. Select Sensor Tests. 4. Select Bin Level. 5. Select Stacker bin level1. <p>Does the display on the operator panel change every time the sensing area of the sensor (stacker bin level 1) is blocked by a multi page document?</p> | Go to step 5. | Go to step 4. |
| 4 | Is the sensor (stacker bin level 1) connected properly? | Replace the sensor (stacker bin level 1). See “Sensor (stacker bin level 1) removal” on page 4-34. | Replace the connection. |
| 5 | <p>Check the sensor (stacker bin level 2) for correct operation.</p> <p>Perform the Stacker bin level2 test.</p> <ol style="list-style-type: none"> 1. Enter Diagnostics mode. 2. Select FINISHER TESTS. 3. Select Sensor Tests. 4. Select Bin Level. 5. Select Stacker bin level2. <p>Does the display on the operator panel change every time the sensing area of the sensor (stacker bin level 2) is blocked by a multi page document?</p> | Go to step 7. | Go to step 6. |
| 6 | <p>Check the sensor (stacker bin level 2) connection.</p> <p>Are the connections of the main sensor cable assembly correctly connected?</p> | Replace the sensor (stacker bin level 2). See “Sensor (stacker bin level 2) removal” on page 4-34. | Replace the connection. |
| 7 | <p>Check the stacker bin lift motor assembly by blocking the lower hole in either of the sensor (stacker bin level). The stacker bin should lower slightly.</p> <p>Does the stacker bin lift motor assembly rotate normally?</p> | Go to step 9. | Go to step 8. |
| 8 | Is the stacker bin lift motor assembly connected properly? | Replace the stacker bin lift motor assembly. See “Stacker bin lift motor assembly removal” on page 4-38. | Replace the connection. |

| Step | Check | Yes | No |
|------|--|--|-----------------|
| 9 | Perform a test print. Does the error still occur? | Replace the finisher controller card assembly. See “Finisher controller card assembly removal” on page 4-118. | Problem solved. |

Stacker set over count failure

| Step | Check | Yes | No |
|------|---|--|-----------------------------------|
| 1 | Check connectors of the finisher controller card assembly connection. Are all the connectors connected to the finisher controller card assembly correctly connected? | Go to step 3. | After reconnecting, go to step 2. |
| 2 | Does the error still occur when the power is turned on? | Go to step 3. | Problem solved. |
| 3 | Replace the finisher controller card assembly. Does the error still occur when the power is turned on? | Replace the printer engine card assembly. Refer to the <i>Printer Service Manual</i> . | Problem solved. |

Staple cartridge empty

| Step | Check | Yes | No |
|------|--|---------------|---|
| 1 | Check the staple cartridge for new and unused staples. Does the staple cartridge have a sufficient amount of new and unused staples? | Go to step 2. | Refill the cartridge with new and unused staples. |
| 2 | Check the staple cartridge for correct installation. Is the staple cartridge installed properly? | Go to step 3. | Install the staple cartridge correctly. |
| 3 | Check the staple cartridge for damage. Is the staple cartridge damaged? | Go to step 4. | Replace the staple cartridge. |
| 4 | Check the sensor (low staple) for correct operation. Perform the low staple test. 1. Enter Diagnostics mode. 2. Select FINISHER TESTS . 3. Select Punch and Staple . 4. Select Low Staple . Does the display on the operator panel change every time an undamaged and filled staple cartridge is removed and reinserted into the stapler unit assembly? | Go to step 6. | Go to step 5. |

| Step | Check | Yes | No |
|------|---|---|-------------------------|
| 5 | Check the stapler unit cable assembly connection. Are all the connections of the stapler unit cable assembly connected properly? | Replace the stapler unit assembly. Go to “Stapler unit assembly removal” on page 4-56. | Replace the connection. |
| 6 | Perform a stapled print test. Does the error still occur? | Replace the finisher controller card assembly. Go to “Finisher controller card assembly removal” on page 4-118. | Problem solved. |
| 7 | Perform a stapled print test. | Replace the printer engine card assembly. Refer to <i>Printer Service Manual</i> . | Problem solved. |

3. Diagnostic aids

This chapter explains the finisher tests and procedures and information to identify finisher failures and verify repairs have corrected the problem. Refer to the *Printer Service Manual* for the entire Diagnostics mode and Configuration menus. Also descriptive information in **“Theory” on page 3-4** explains the processes and is helpful in understanding the finisher.

Diagnostics are built into the printer RIP card assembly and can be accessed from the printer operator panel.

Accessing Diagnostics mode

There are different test menus that can be accessed during POR to identify problems with the printer.

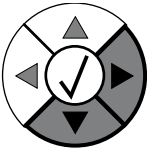
| | | |
|------------------|--|--|
| Diagnostics mode | <ol style="list-style-type: none"> 1. Turn off the printer 2. Press and hold ▼ and ►.  <ol style="list-style-type: none"> 3. Turn on the printer. 4. Release the buttons when the clock face appears. | <p>The Diagnostics mode group contains the settings and operations used while manufacturing and servicing the printer and finisher.</p> <p>See “Available finisher tests” on page 3-1 for more information.</p> |
|------------------|--|--|

To run the printer diagnostic tests described in this chapter, you must put the printer in Diagnostics mode.

Available finisher tests

This is a partial list of the tests available to the printer. Details below are for the finisher, only. The tests display on the operator panel in the order shown:

Finisher tests from Diagnostics mode

| FINISHER TESTS | |
|------------------|---|
| Staple Test | See “Staple Test” on page 3-2 |
| Hole Punch Test | See “Hole Punch Test” on page 3-2 |
| Feed Tests | See “Feed Tests” on page 3-2 |
| Sensor Test | See “Sensor Test (finisher)” on page 3-2 |
| Cover and Door | |
| Bin Level | |
| Media Path1 | |
| Media Path2 | |
| Punch and Staple | |

FINISHER TESTS

Staple Test

This test verifies the staple mechanism by sending eight sheets of media from the printers default paper source and stapling the sheets.

To run the Staple Test:

1. Select **FINISHER TESTS** from DIAGNOSTICS.
2. Select **Staple Test** from FINISHER TESTS.
3. Select the output bin and press .

While the test runs the power indicator *blinks* and the message `Staple Test Running...` displays. Select **Stop** () to exit the test before it completes.

Hole Punch Test

This test is used to verify whether or not media can be fed to a finisher output bin and punched. Eight sheets of blank paper are fed from the default paper source and fed to the finisher output bins. Letter size paper is used for the 3 hole test and A4 media is used for the 4 hole test. Media is selected from the default tray.

To run the Feed Test:

1. Select **FINISHER TESTS** from DIAGNOSTICS.
2. Select **Feed Tests** from FINISHER TESTS.

While the feed test runs the power indicator *blinks* and the message `Feed Test Running...` displays.

During the test, no buttons are active and the test cannot be stopped until the test is completed.

Feed Tests

This test is used to verify whether or not media can be fed to a finisher output bin. Eight sheets of blank paper are fed from the default paper source and fed to the finisher output bins.

Note: This test can be run using any of the paper sizes supported by the printer.

To run the Feed Test:

1. Select FINISHER TESTS from DIAGNOSTICS.
2. Select **Feed Tests** from FINISHER TESTS.

While the feed test runs the power indicator *blinks* and the message `Feed Test Running...` displays.

During the test, no buttons are active and the test cannot be stopped until the test is completed.

Sensor Test (finisher)

This test can be used to verify whether or not the finisher sensors are working correctly.

To run the finisher Sensor Test:

1. Select **FINISHER TESTS** from DIAGNOSTICS.
2. Select **Sensor Test** from FINISHER TESTS.
3. Select one of the test categories:
 - **Cover and Door**
 - **Bin Level**
 - **Media Path1**
 - **Media Path2**
 - **Punch and Staple**

4. Select the actual test to perform.

Each of the tests categories includes the individual sensors that can be manually actuated and the display shows **O**pen or **C**losed.

- **Cover and Door**
 - Cover F bridge top
 - Door G fin front
 - Surface H fin eject
- **Bin Level**
 - Fin upper bin full
 - Stacker bin level1
 - Stacker bin level2
 - Stacker bin upper limit
 - Stacker bin no media
 - Stacker bin level encod
- **Media Path1**
 - Fuser exit
 - Bridge media ent
 - Bridge media exit
 - Fin media ent
 - Buffer path
 - Upper media exit
 - Lower media exit
 - Compiler media in
- **Media Path2**
 - Diverter gate
 - Front tamper hp
 - Rear tamper hp
 - Eject clamp hp
 - Media eject shaft hp
- **Punch and Staple**
 - Punch side reg1
 - Punch side reg2
 - Punch box set
 - Punch waste full
 - Low staple
 - Punch carriage shift hp
 - Punch unit hp
 - Stapler carriage shift hp
 - Punch cam front
 - Punch hole select

Press **Back** (↶) or **Stop** (⊗) to exit the test.

EXIT DIAGNOSTICS

This selection exits Diagnostics mode and Resetting the Printer displays. The printer performs a POR and the printer returns to normal mode.

Theory

Media transport

This section describes transfer of media from the printer to a specified bin.

The following figures illustrate layouts (side view viewing from the front side) of sensors, rollers, and main blocks, as well as a layout (rear view) of the main components.

Bridge unit assembly paper path

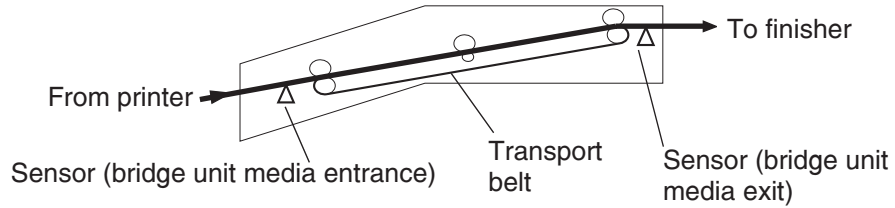

Finisher media path

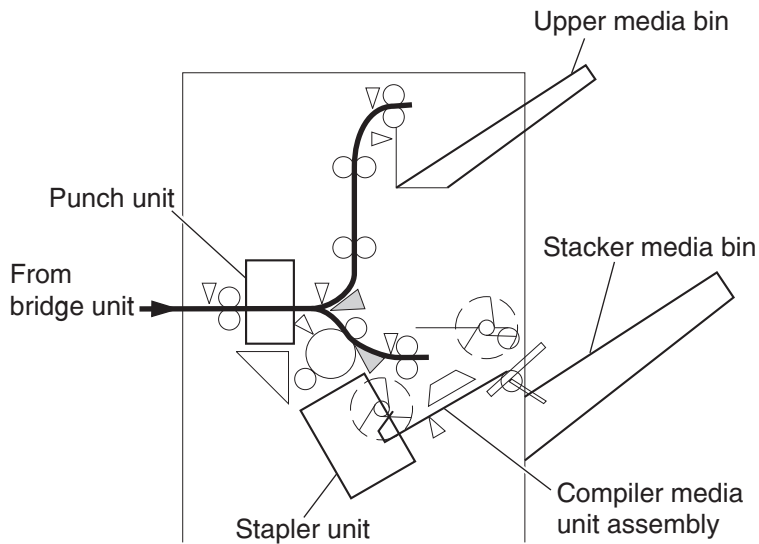

Finisher roll assemblies

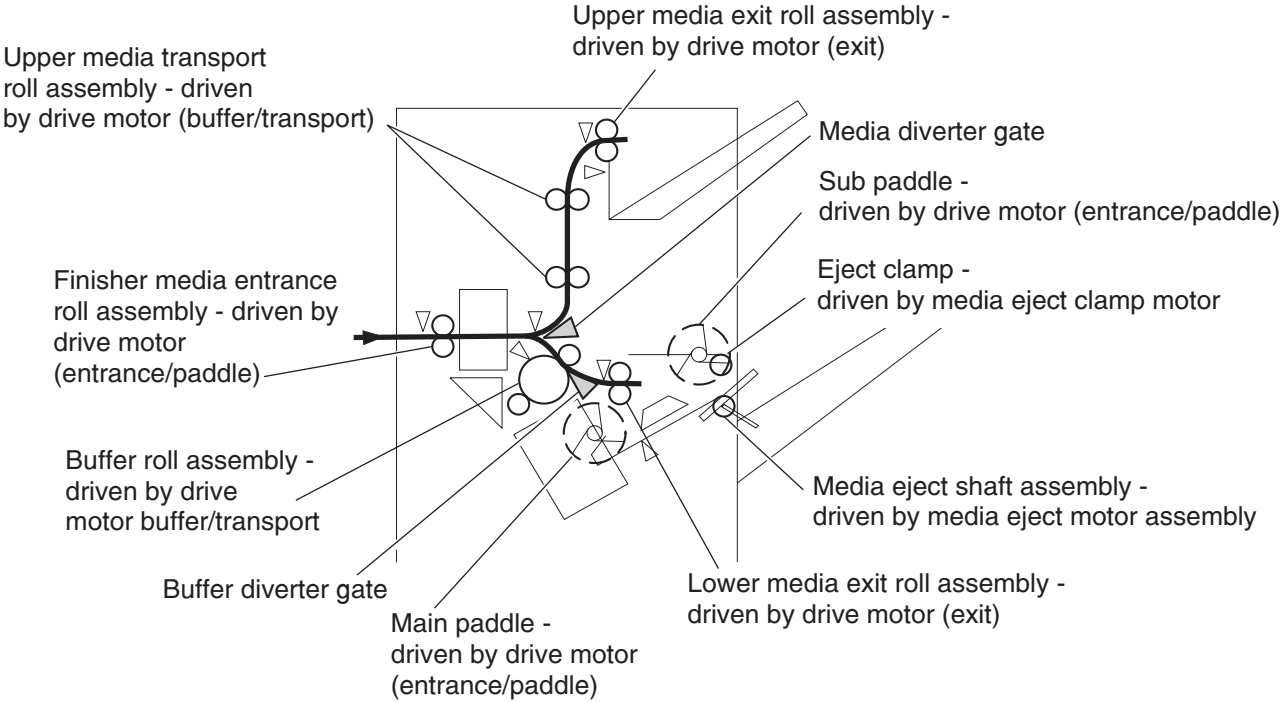

Finisher media path sensors

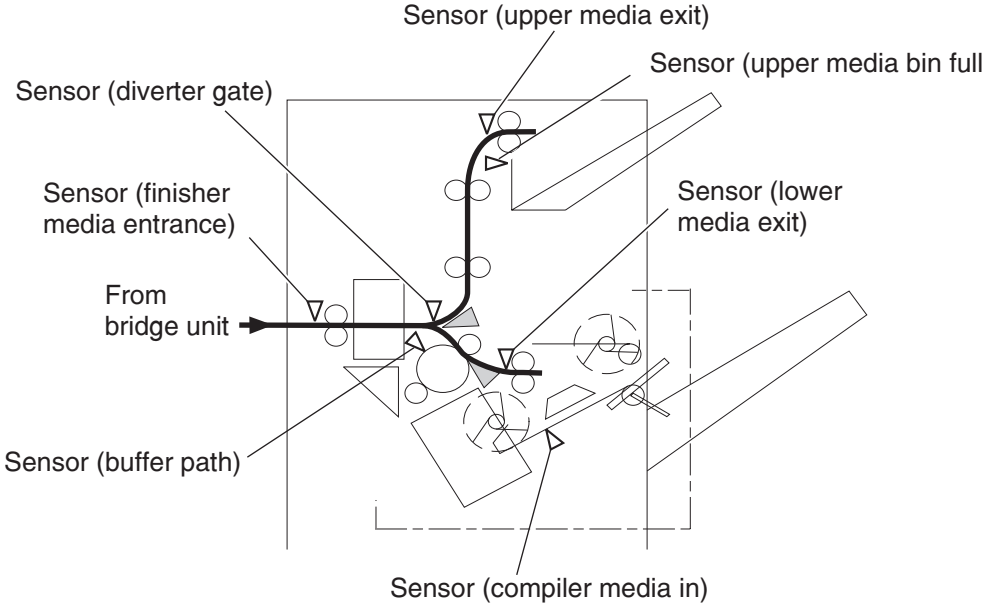

Finisher motors

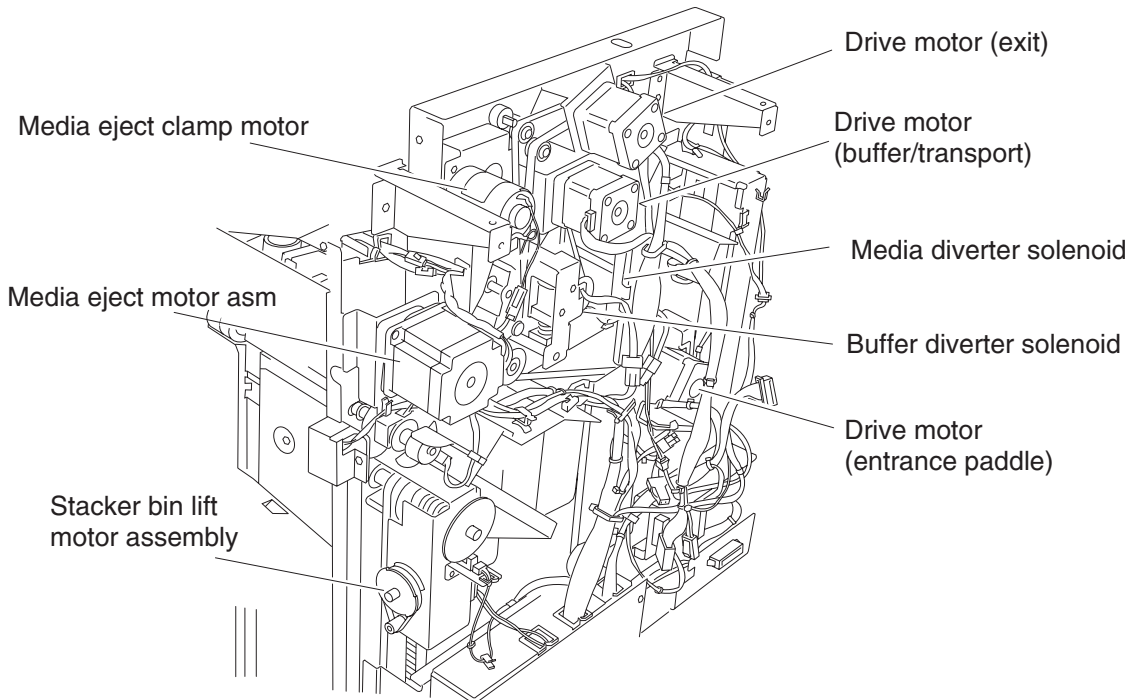

Bridge unit assembly

When the finisher is designated by the command of printer, the media diverter gate in the printer activates and media is fed from the printer into the bridge unit assembly.

The bridge unit drive motor is activated by the trigger of printer's registration clutch on to drive the transport belts in the bridge unit assembly. The motor power is transmitted to the two belts between bridge unit right shaft assembly and bridge unit left shaft assembly.

The media fed to the bridge unit assembly is securely held between the transport belts and the pinch rolls, and fed to the finisher.

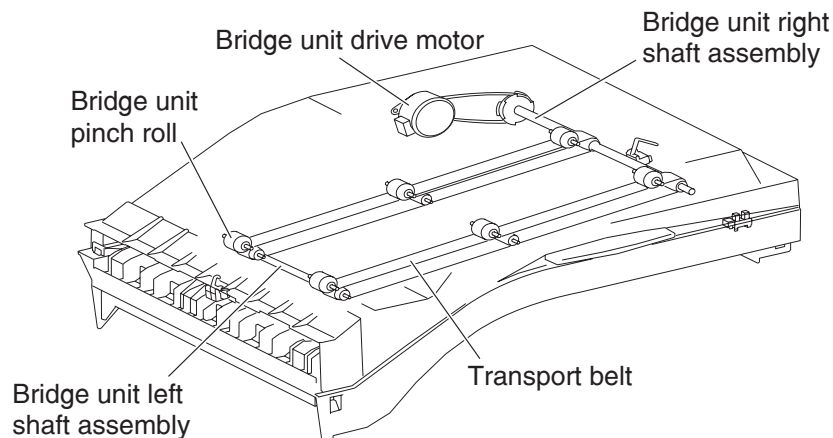

From bridge unit assembly to punch

The media fed from the bridge unit assembly is fed into the finisher by the media entrance roll assembly located on the entrance section of the finisher that is driven by the motor (entrance/paddle).

The media route inside the finisher is determined by the media diverter gate.

The media diverter gate is activated by the media diverter gate solenoid controlled by the printer.

The media is further fed in the finisher by the two upper media transport roll or the buffer roll assemblies that are driven by the motor (buffer/transport), and passes through the punch unit.

The sensor (finisher media entrance) becomes "LOW" upon detecting media. After a certain time has passed from the level transition to "H", the motor (buffer/transport) that drives the upper media transport roll assembly or the buffer roll assembly starts reverse rotation.

The media is returned to the punch unit by the upper media transport roll assembly or the buffer roll assembly assembly, and is stopped with its end gently pressed against the three punch media stopper assemblies.

The three punch media stopper assemblies in the punch unit drop to let media pass through when feeding media to the exit (while the motor (buffer/transport) is rotating forward), but rises when media is returned (while the motor (buffer/transport) is rotating reversely) to stop the media.

Thus, punch hole positions in the media feed direction are determined.

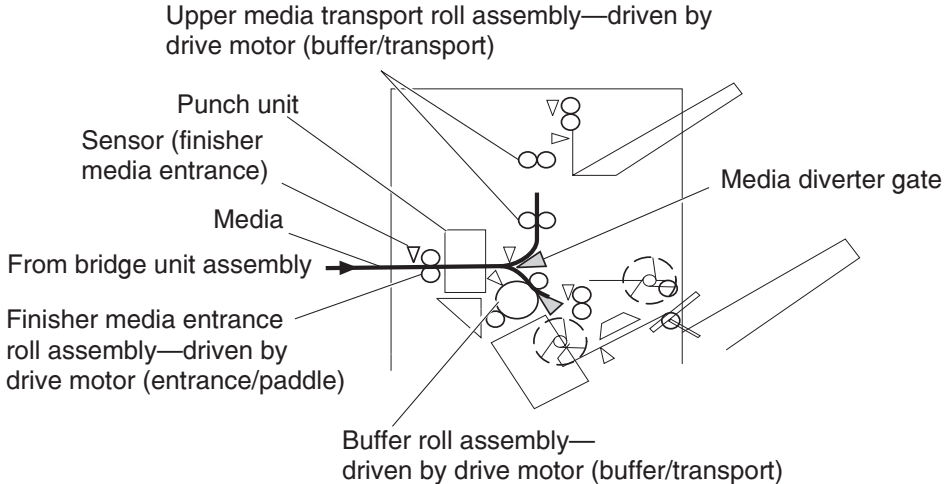
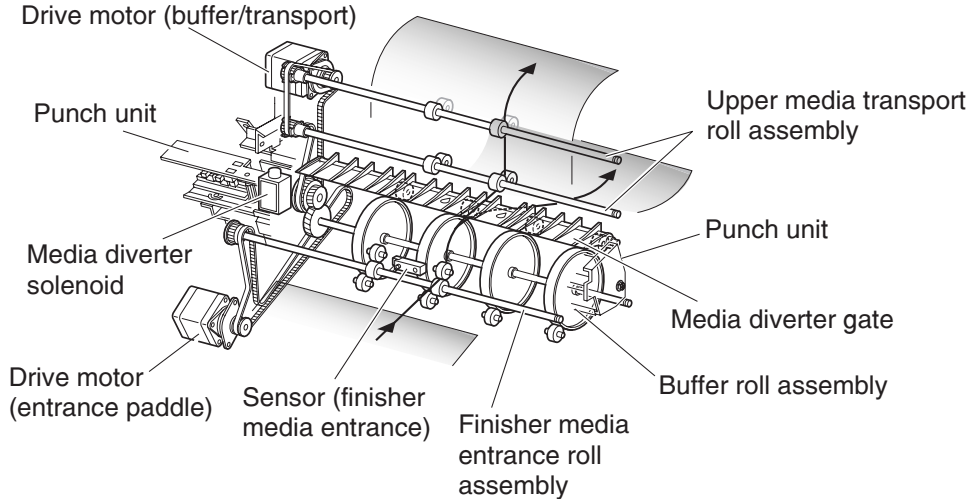

From punch to compiler unit assembly

The media is transferred to the compiler unit assembly by the buffer roll assembly (driven by the motor (buffer/transport) and by the lower media exit roll assembly driven by the drive motor (exit).

When the first media reaches the compiler unit assembly, the media eject clamp motor is activated to lower the media eject clamp so that the media eject clamp and the media eject shaft assembly can clamp the media.

Thus, the media transferred from the punch unit is held by the media eject shaft assembly and the media eject clamp driven by the media eject motor assembly and is fed to the exit.

When the media trailing edge passes through the sensor (lower media exit), the media eject motor assembly starts reverse rotation to return the media to the compiler unit assembly.

When the following media reaches the compiler unit assembly, the media eject clamp is raised, and the media that has passed through the lower media exit roll assembly falls on the compiler unit assembly.

At this time, the three main paddles are rotated by the main paddle shaft assembly to feed the media so that the media trailing edge butts against the rear wall of the compiler unit assembly.

The sub paddle solenoid of the media eject unit assembly is activated to lower the sub paddle so that the media can be fed to the compiler unit assembly.

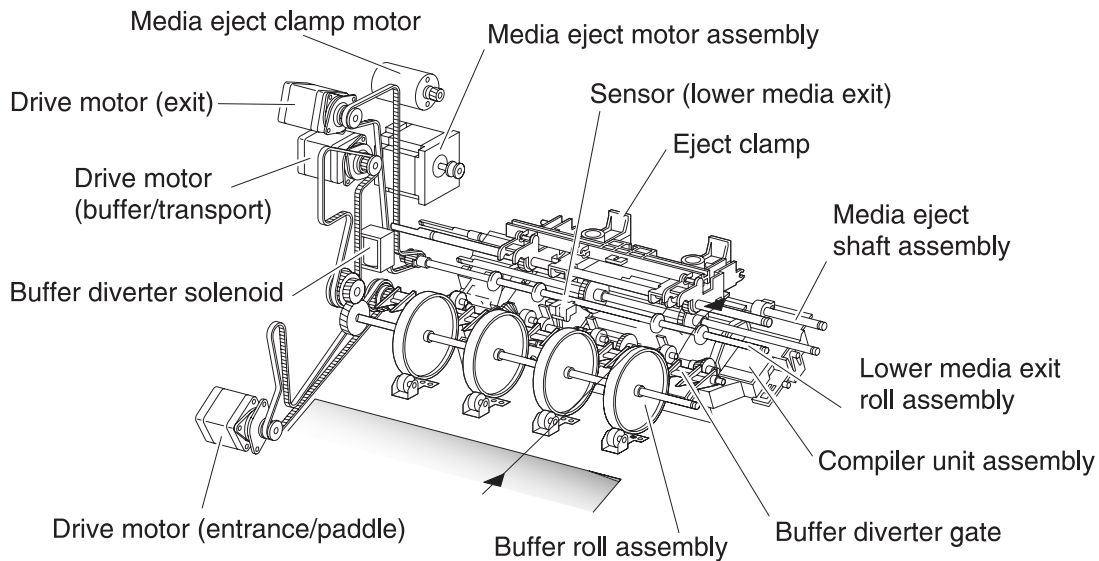

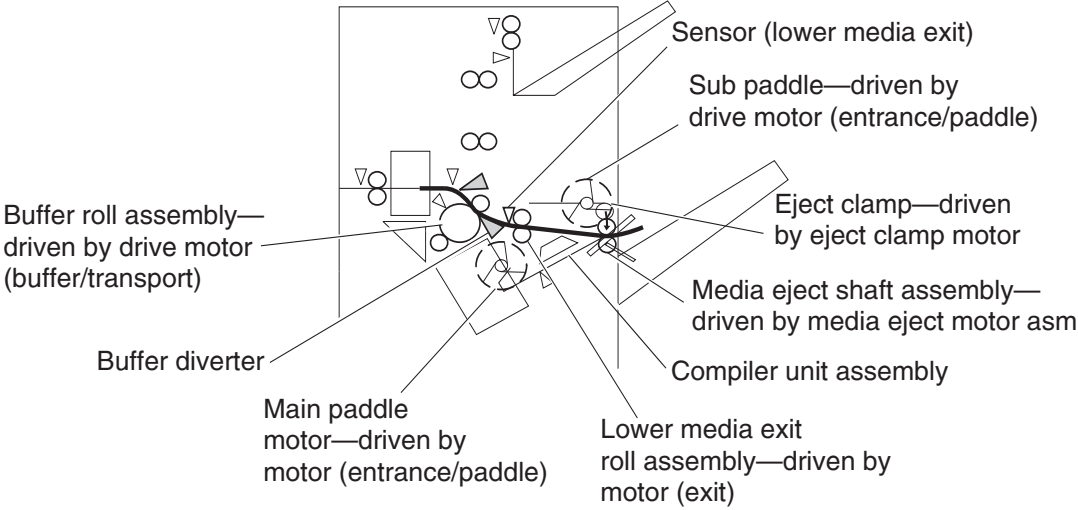

When printing multiple sets, while stapling the first set on the compiler unit assembly or ejecting it to the stacker media bin, the first media of the second set will not be fed to the compiler unit assembly.

When the first media of the second set reaches the finisher, the buffer diverter solenoid is activated by the printer command and by the sensor (finisher media entrance) to switch the buffer diverter gate.

Thus, the media route is switched into the buffer roll assembly's circumferential direction. (This operation is called "buffer path".)

The first media of the second set is aligned with the second media, and then they are fed together to the compiler unit assembly.

Even for one sheet of media, the buffer path operation is executed in the same way. The media is stacked temporarily on the compiler unit assembly, and then ejected in the stacker media bin.

After buffer path is executed for the first media, if the second media of a different size comes, the first media is fed to the compiler unit assembly, but the second one is fed to the compiler unit assembly without buffer path. At this time, a certain delay time is provided to avoid the second media from colliding with the first one.

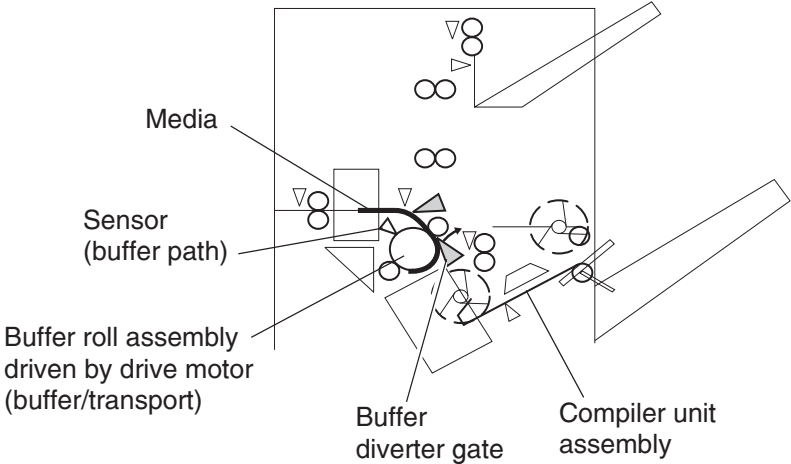

From compiler unit assembly to stacker media bin

Stapled media on the compiler unit assembly (stapling mode) or aligned media (non-stapling mode) are held between the media eject clamp and the media eject shaft assembly.

The media eject shaft assembly is driven by the media eject motor assembly to transfer media to the stacker media bin.

After media is transferred to the stacker media bin, it is held by the clamp paddle attached to the media eject shaft assembly.

From punch to upper media bin

The media to be ejected to the upper media bin is switched in the media path by the media diverter gate located behind the punch and fed in the upper media transport roll assembly direction.

The media diverter gate is switched by the media diverter gate solenoid. While the solenoid is activated, media is fed in the upper media transport roll assembly direction.

The two upper media transport roll assembly driven by the motor (buffer/transport) feed media to the upper media exit roll assembly top at the top of the finisher.

The upper media exit roll assembly top driven by the drive motor (exit) to eject the media to the upper media bin.

The upper media exit roll assembly decelerates after a specified period of time from the following trigger events.

Functions of sensors along the media path

Bridge unit assembly

- Sensor (bridge unit media entrance)
 - A photo-interrupter to detect whether media is fed from the printer to the bridge unit assembly
 - It turns “H” (+5 V dc) (light receiving) when media enters the bridge unit assembly.
- Sensor (bridge unit media exit)
 - A photo-interrupter to detect whether media passes through the bridge unit assembly
 - It turns “H” (+5 V dc) (light receiving) when media reaches this sensor, and turns “L” (0 V dc) when media exits from the bridge unit assembly.
- Sensor (bridge unit top cover interlock)
 - A photo-interrupter to detect open/close of the bridge top cover assembly of the bridge unit assembly
 - It turns “H” (+5 V dc) (light receiving) when the bridge top cover assembly opens.

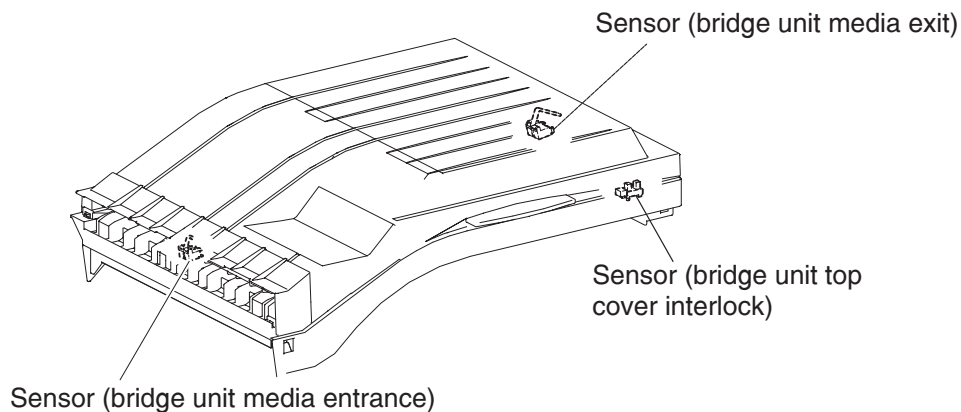

Finisher

- Sensor (finisher media entrance)
 - A reflective photo-sensor to detect whether media is fed from the bridge unit assembly to the finisher
 - It turns “H” (+5 V dc) while media is present within the sensing area.
 - When the level turns “H” due to the first media of the second set during multi-set printing, activates the buffer diverter solenoid to switch the buffer diverter gate so that the media goes in the buffer roll assembly’s circumferential direction.
- Sensor (diverter gate)
 - A reflective photo-sensor to detect the media leading edge
 - It turns “L” (0 V) when the front end reaches the sensing area.
- Sensor (lower media exit)
 - A photo-interrupter to detect whether media passes through the sensor (lower media exit)
 - It turns “H” (+5 V) (light receiving) when the actuator is driven out of the sensing area by the media.
 - When the level turns “H”, activates the front tamper motor and the rear tamper motor on the compiler unit assembly.
 - This sensor is also used to control on/off of the media eject motor assembly.
- Sensor (compiler media present)
 - A photo-interrupter to detect whether media is present or not on the compiler unit assembly.
 - While media is present, the actuator is outside the sensing area, and the sensor turns at “H” (+5 V dc) (light receiving).
- Sensor (buffer path)
 - A photo-interrupter to detect whether media is fed toward the buffer roll assembly
 - While media is present, the actuator is outside the sensing area, and the sensor turns at “H” (+5 V) (light receiving).
- Sensor (upper media exit)
 - A photo-interrupter to detect whether media is fed to the upper media exit roll assembly Top at the exit side of the upper media bin
 - When the media is fed, the actuator leaves from the sensing area, and the sensor turns “H” (+5 V).
- Sensor (upper media bin full)
 - A reflective photo-sensor to detect the stack volume of media in the upper media bin.

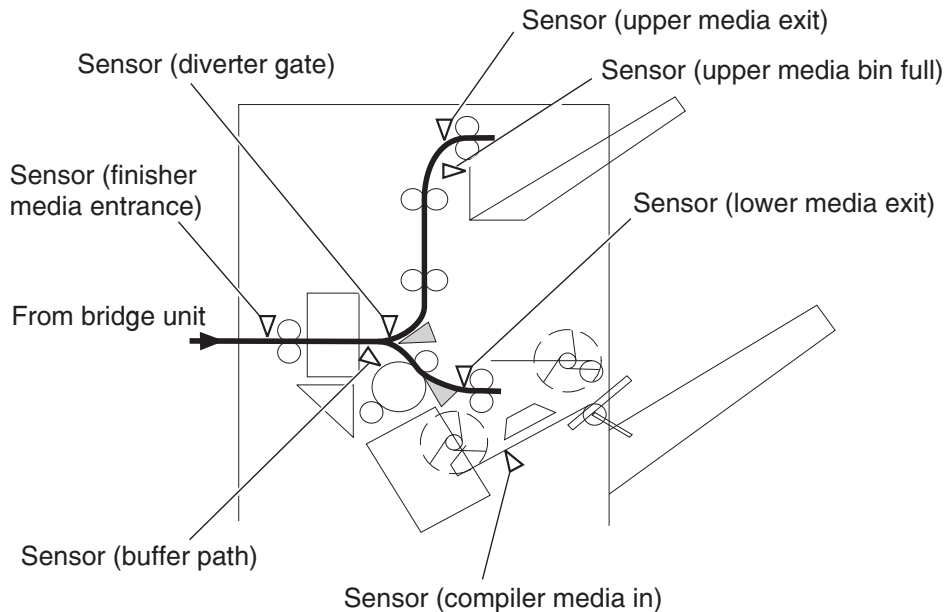

Punch unit

This section describes the media punching operation of the punch.

Two types of punch are provided: the 2/3-hole type and the 2/4-hole type.

The following explains the 2/3-hole type (2-hole/3-hole auto-switching).

Every type has the same construction, except for the sensor (punch hole select) that is provided for the 2-hole type and 3-hole type only.

Adjusting punching positions

The punching positions from the media edge in the direction of feed are determined by gently pressing the media against the three punch media stopper assemblies.

While the three punching positions from the media edge in the direction of media width are determined by the following method.

- Activate the punch carriage shift motor assembly and move the punch to the front side until the sensor (punch carriage shift HP) turns "L".
- Rotate reversely the motor and move the punch to the rear side until the sensor turns "H" to determine the home position.
- The punch carriage shift motor assembly is activated to move the punch to the front until the sensor (punch unit side registration 1) and the sensor (punch unit side registration 2) detects the media edge, and then the punch is further moved to the front according to the pulse-number determined by the media size. (The punch carriage shift motor assembly stops at this position.)

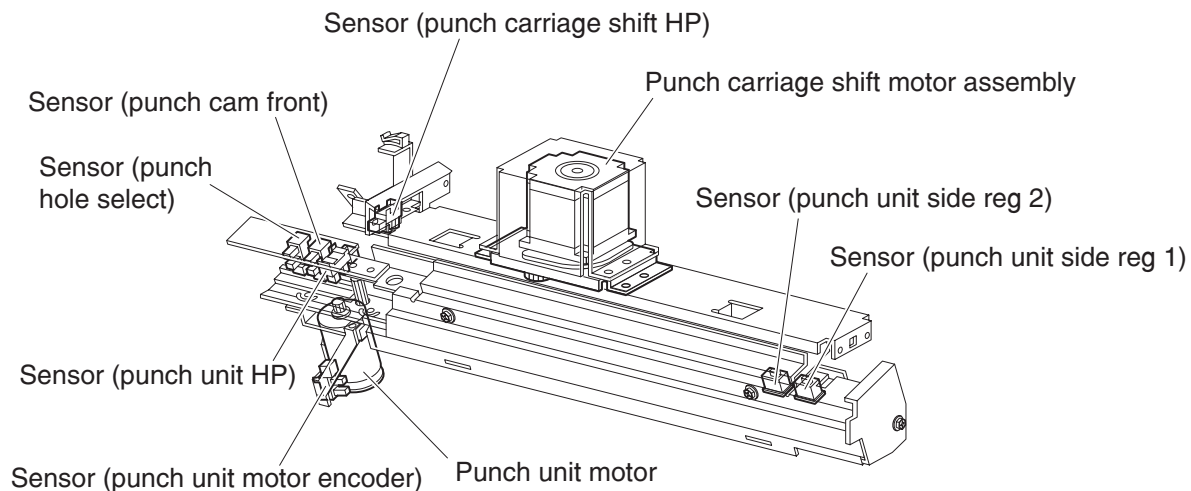

Punching

After punching positions are determined, the punch unit motor is activated to move the cam plate. With the movement of the cam plate, the pins descend along the guide holes to punch the media.

This operation is performed for each sheet of media.

The cam plate can lower the pins even while it is moving to the front or rear side.

The punch unit motor is rotated forward or reversely for each sheet of media, which is triggered by the sensor (punch cam front) on/off.

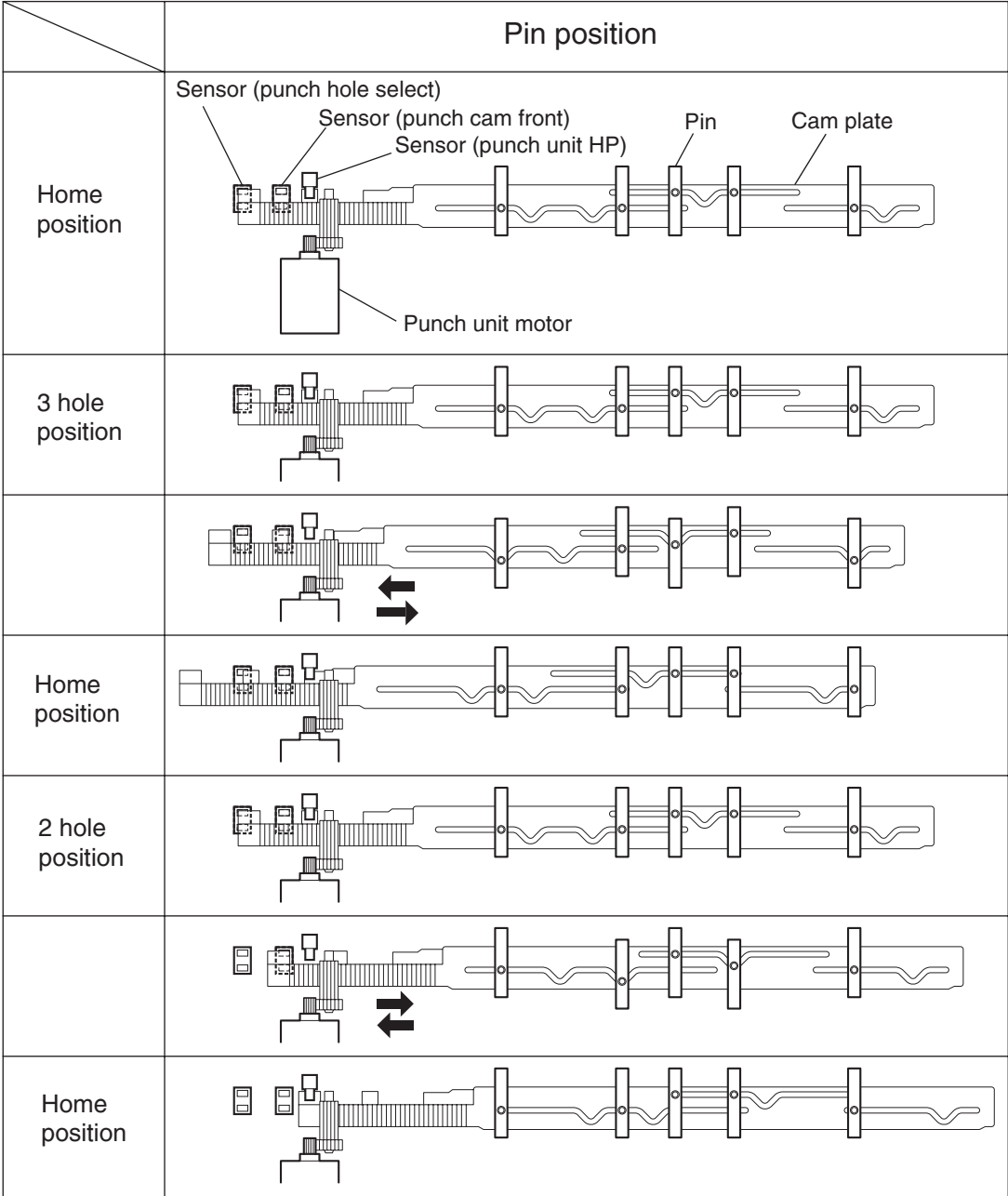

Detecting punch waste full

Punch waste is stored in the punch waste box.

A sensor is provided to detect punch waste full.

When punch waste full is detected, it is notified to the operator only once.

Even if punch waste is not removed, the finisher can still punch media. However it can spread punch waste inside the machine.

Detecting punch waste box

The sensor (punch waste box set) detects whether the punch waste box is properly set.

When the sensor (punch waste box set) does not detect that the punch waste box is properly set for four seconds, the punch waste box count is reset.

Functions of punch sensors/motors

- Sensor (punch unit side registration 1)
 - A reflective photo-sensor to detect the side edge of large media
 - Media side edge is detected by On/Off of this sensor while shifting the punch (containing this sensor) in the direction of media width.
 - The sensor remains at “H” (+5 v dc) while media is present, and turns “L” when media side edge is detected.
- Sensor (punch unit side registration 2)
 - A reflective photo-sensor to detect the side edge of small media
 - This sensor has the same function as the sensor (punch unit side registration 1).
- Sensor (punch carriage shift HP)
 - A photo-interrupter to detect the home position of the moving punch
 - It turns “H” (+5 v dc) (light blocking) when the home position is detected.
- Sensor (punch unit HP)
 - A photo-interrupter to detect the home position of the cam plate that lowers the punching pins
 - It turns “H” (+5 V dc) when the home position is detected.
- Sensor (punch hole select)
 - A photo-interrupter to detect the rear position of the cam plate
 - It turns “H” (+5 V dc) when the rear position is detected.
 - This sensor also detects the Cam position to switch punch holes (2-hole/3-hole).
- Sensor (punch cam front)
 - A photo-interrupter to detect the front position of the cam plate
 - It turns “H” (+5 V dc) when the front position is detected.
 - This sensor is used to determine to which side (front or rear) the cam plate should be moved.
- Sensor (punch unit motor encoder)
 - A photo-interrupter to detect pulse generated by the encoder attached to the punch unit motor
 - It counts punch unit motor revolutions, and becomes a trigger to stop the motor (by shutting off the current).
- Punch carriage shift motor assembly
A stepping motor to move the punch in the media width direction
- Punch unit motor
 - A DC motor to move the cam plate that lowers the punching pins
 - Forward rotation of the motor moves the cam plate to the front side, and reverse rotation moves it to the rear side.

- Sensor (punch waste box set)
 - A photo-interrupter to detect whether the waste box is properly set
 - When the punch waste box is properly set, the actuator of the box blocks the light transmission of the sensor, which turns the sensor to “H” (+5 V dc).
- Sensor (punch waste box full)
 - A photo-interrupter to detect the punch waste box is filled with punch waste.

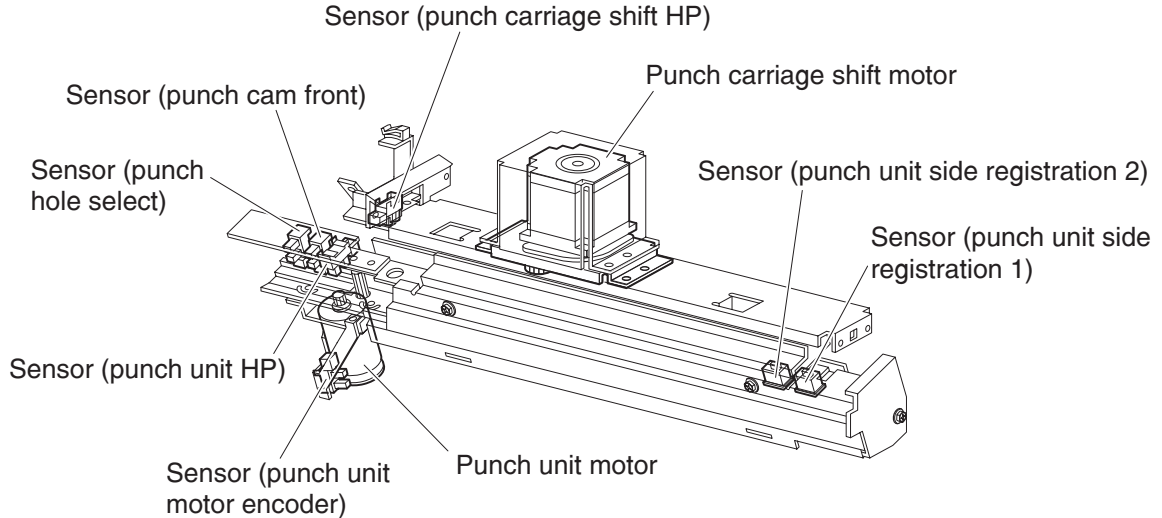

Compiler unit assembly

This section describes the operation of the compiler unit assembly that aligns the media edge transferred from the punch unit.

Outline of operation

When media is fed onto the compiler unit assembly, tamping operation is performed to align the media edge in the media width direction.

When ejecting stapled sets of media to the stacker media bin, if they are stacked in the stacker media bin with the same staple position, the height of the stapled portion will increase. This will cause improper compiling of media due to butting of the following media. To prevent such improper compiling, offsetting is required by shifting the staple position between sets of media.

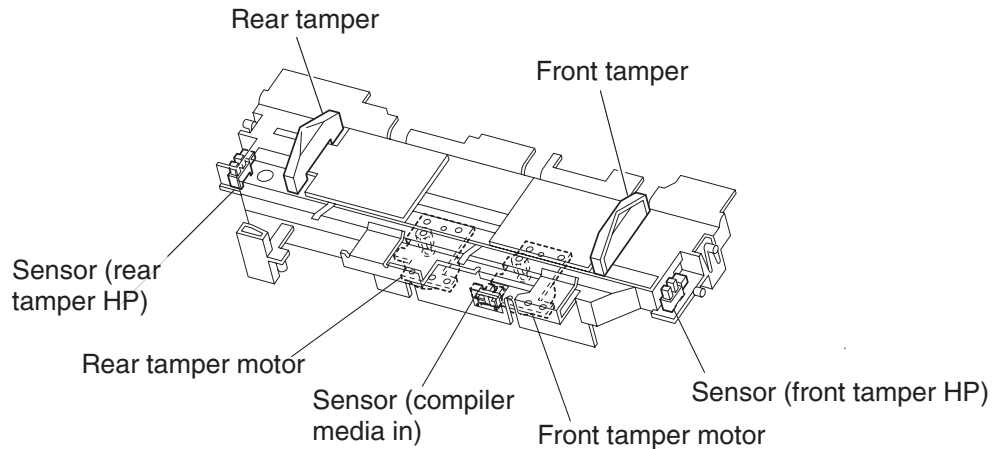

Capacity of compiler unit assembly

Media volume that can be stacked on the compiler unit assembly is limited as shown in the table below.

The number of sheets depends on whether media is stapled or not, as well as on media size.

If the number of sheets of one set to be stapled exceeds the limit, the exceeding sheets are not stacked on the compiler unit assembly, and are forcibly ejected to the stacker media bin without being stapled.

This forcible ejection is performed to prevent damage to the staple assembly.

When feeding large media in the non-staple mode, there may be a misalignment depending on media characteristics. For this reason, the default media capacity is set to a smaller value.

Compiler unit assembly media capacity

| Condition | Min. | Default | Max. |
|---|------|---------|------|
| Staple mode | 2 | 50 | 75 |
| For small media (less than 216 mm in the feed direction) in non-staple mode | 10 | 50 | 100 |
| For large media (216 mm or more in the feed direction) in non-staple mode | 10 | 25 | 100 |

Compiler unit assembly operation with multiple media sizes

When two or more media sizes are used and their widths are same (example: A4L and A3S), all the sheets are compiled and stapled as a set on the compiler unit assembly, and then ejected to the stacker media bin.

While if two or more media sizes with different media width are used, stapling media on the compiler unit assembly is stopped when a different size is detected. Such different-size sheets of media are forcibly ejected to the stacker media bin.

Tamping

When media is fed from the punch to the compiler unit assembly, tamping operation is performed to align the media in the media width direction on the compiler unit assembly.

Tamping is an operation to align media to the specified position on the compiler unit assembly using the front tamper or rear tamper by moving them to the end of media by the respective motors.

Tamping is executed each time when a sheet of media reaches the compiler unit assembly. Additional tamping is executed after tamping the last sheet.

There are three types of tamping.

- Front tamping—tamping by the rear tamper with the front tamper fixed at the home position
- Rear tamping—tamping by the front tamper with the rear tamper fixed at the home position
- Center tamping—tamping by the front and rear tampers to align media to the almost center

Front tamping

Front tamping is used in the following cases.

- In the non-staple mode
- When executing front stapling (corner)

The tamper positions during front tamping are shown below.

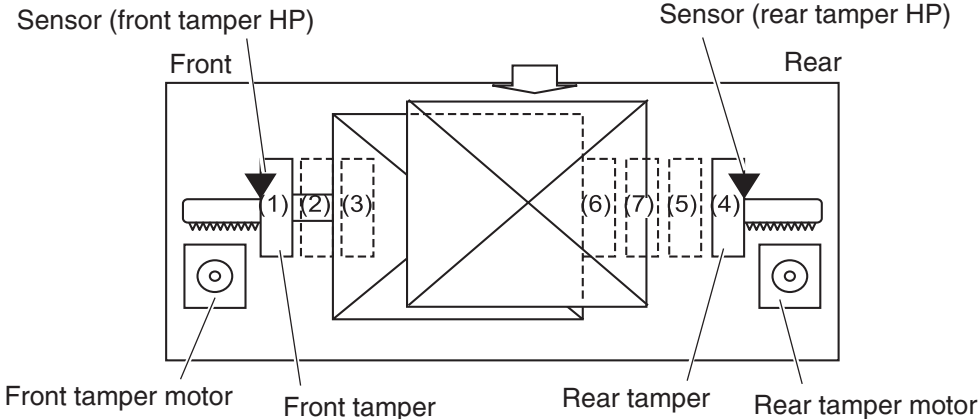

| Position | Description |
|----------|---|
| 1 | Front tamper home position—sensor (front tamper HP) |
| 2 | Front tamper size position |
| 3 | Front tamper offset position |
| 4 | Rear tamper home position—sensor (rear tamper HP) |
| 5 | Rear tamper standby position |
| 6 | Rear tamper tamping position |
| 7 | Rear tamper offset position |

Rear tamping

Rear tamping is used in the following cases.

- When executing rear stapling (corner)
- When executing dual stapling

The tamper positions during rear tamping are shown below.

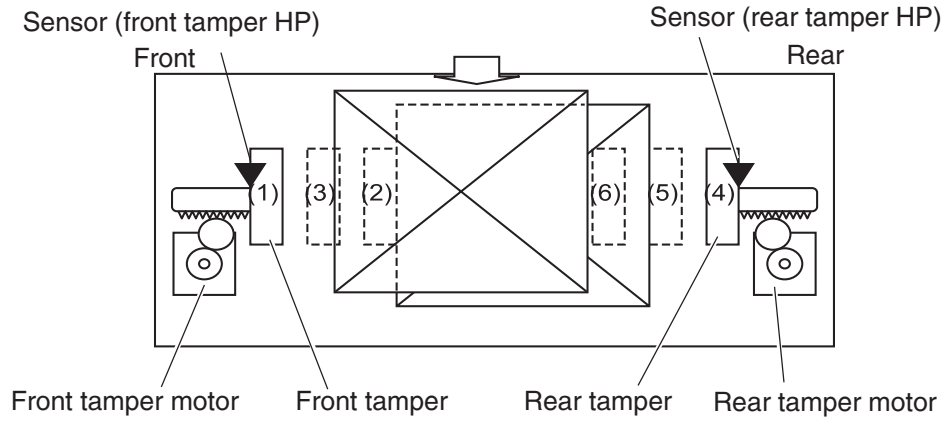

| Position | Description |
|----------|---|
| 1 | Front tamper home position—sensor (front tamper HP) |
| 2 | Front tamper tamping position |
| 3 | Front tamper offset position |
| 4 | Rear tamper home position—sensor (rear tamper HP) |
| 5 | Rear tamper size position |
| 6 | Rear tamper offset position |

Center tamping

Center tamping is used when executing rear stapling (straight).

The tamper positions during center tamping are shown below.

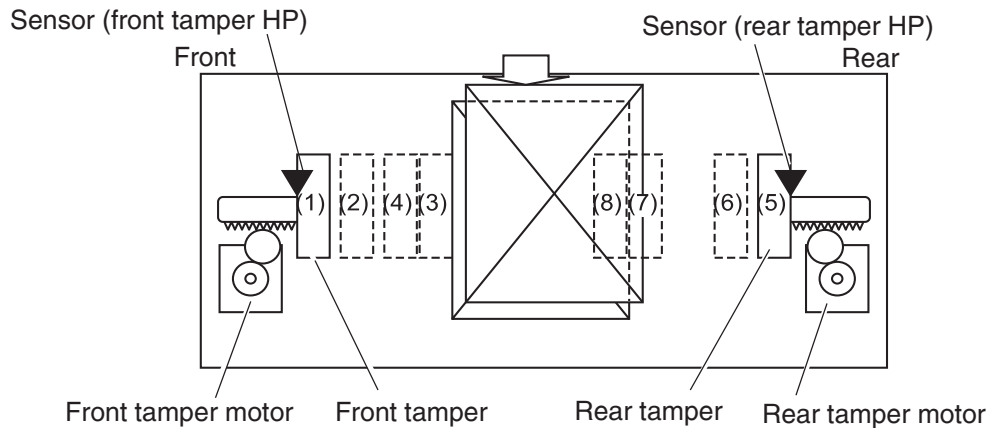

| Position | Description |
|----------|---|
| 1 | Front tamper home position—sensor (front tamper HP) |
| 2 | Front tamper standby position |
| 3 | Front tamper tamping position |
| 4 | Front tamper offset position |
| 5 | Rear tamper home position—sensor (rear tamper HP) |
| 6 | Rear tamper standby position |
| 7 | Rear tamper size position |
| 8 | Rear tamper offset position |

Determining tamper home position

When the sensor (lower media exit) turns “H” (+5 V dc) (light receiving), the front and rear tamper motors on the compiler unit assembly are activated, and the front and rear tampers start moving.

The front tamper home position is determined when the front tamper enters the sensor (front tamper HP) sensing area.

In the same way, the rear tamper home position is determined when the rear tamper enters the sensor (rear tamper HP) sensing area.

Tamping

Tamping is executed after a preset time has passed after the sensor (compiler media present) turns “H” (+5 V dc) when media is detected on the compiler unit assembly.

Offsetting

Offsetting is an operation to shift the position of media to be ejected to the stacker media bin so that boundaries between media units (sets of media, job unit, etc.) can be easily recognized.

Offsetting is executed for staple positions:

- During front stapling (corner)—Shifts stapled sheets using the front tamper by 20 mm to the rear side before ejecting them to the stacker media bin.
- During rear stapling (corner/straight)
 - For media with a width of 216 mm or more [rear staple (corner)]—Shifts stapled sheets using the rear tamper by 20 mm to the front side before ejecting them to the stacker media bin.
 - For media with a width of less than 216 mm [rear staple (straight)]: shifts stapled sheets using the front tamper by 9 mm to the rear side before ejecting them to the stacker media bin.

During dual stapling:

- Shifts stapled sheets using the front tamper by 9 mm to the rear side before ejecting them to the stacker media bin.
- Offsetting is not executed (0 mm) for small media.

Functions of compiler unit assembly sensors/motors

- Sensor (compiler media in)
 - A photo-interrupter to detect whether media is present or not on the compiler unit assembly
 - When media is detected, the actuator leaves the sensing area, which turns the sensor to “H” (+5 V dc) (light receiving).
- Sensor (front tamper HP)
 - A photo-interrupter to detect the front tamper home position
 - When the front tamper comes to the home position, it enters the sensor’s sensing area, which turns the sensor to “H” (+5 V dc) (light blocking).
- Sensor (rear tamper HP)
 - A photo-interrupter to detect the rear tamper home position
 - When the rear tamper comes to the home position, it enters the sensor’s sensing area, which turns the sensor to “H” (+5 V dc) (light blocking).
- Front tamper motor
 - A stepping motor to move the front tamper for tamping
 - Clockwise rotation of this motor moves the front tamper to the rear side. Counterclockwise rotation of this motor moves the tamper to the front side.

- Rear tamper motor
 - A stepping motor to move the rear tamper for tamping
 - Clockwise rotation of this motor moves the rear tamper to the front side. Counterclockwise rotation of this motor moves the tamper to the rear side.

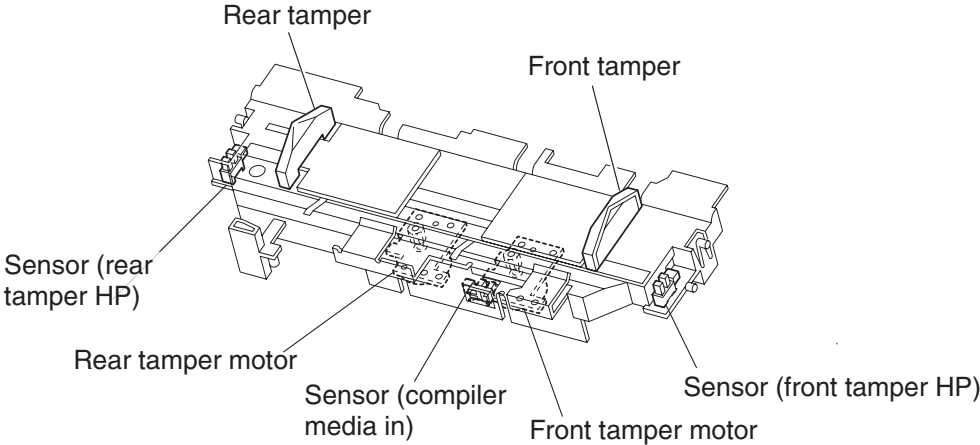

Stapler

This section describes the operation of the stapler.

Stapling operation

Sheets of media fed from the punch are tamped on the compiler unit assembly, and then stapled at specified positions by the command of the printer.

Staple positions

There are four stapling modes:

- Front staple (corner) [Front Corner]

The stapler staples a set of media obliquely (45 degrees) after the rear tamper aligns the media to the front side.
- Rear staple (corner) [rear corner]

This type of stapling is applied for media with a width of 216 mm or more. The stapler moves to the rear corner and staples a set of media obliquely (45 degrees) after the front tamper aligns the media to the rear side.

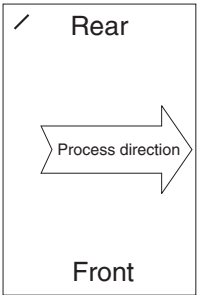
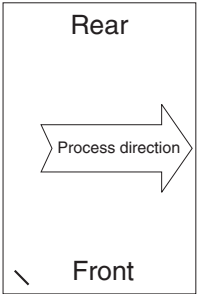

- Rear Staple (Straight) [rear Straight]**
 This type of stapling is applied for media with a width of less than 216 mm.
 The Stapler staples a set of media in parallel with the media edge after the front tamper aligns the media to the rear side.

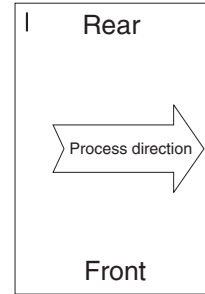

- Dual Staple [Dual]**
 The Stapler staples a set of media at fixed positions (front/rear sides) in parallel with the media edge, after the front tamper aligns the media to the specified position for each media size.

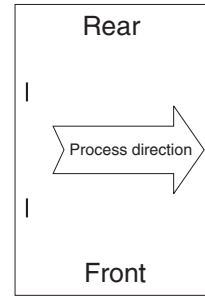

Media sizes that allow stapling

Media size that allows stapling depends on stapling positions.

The following table shows media sizes and the applicability of stapling for each staple position.

| | Front corner | Rear corner | Rear straight | Dual |
|--|--------------|-------------|---------------|------|
| A3 SEF | Yes | Yes | No | Yes |
| A4 LEF | Yes | Yes | No | Yes |
| 11 x 17 in. SEF | Yes | Yes | No | Yes |
| 8.5 x 11 in. LEF | Yes | Yes | No | Yes |
| 8K SEF(GCO), 16K LEF(GCO) | Yes | Yes | No | Yes |
| B4 SEF, B5 LEF | Yes | Yes | No | Yes |
| 8 x 10 in. LEF | Yes | Yes | No | Yes |
| 8.5 x 14 in. SEF / 8.5 x 13 in. SEF / 8.5 x 11 in. SEF | Yes | No | Yes | Yes |
| A4 SEF | Yes | No | Yes | Yes |
| 8 x 10 in. SEF | Yes | No | Yes | Yes |
| Yes: Applicable, No: Not applicable | | | | |

Stapling one sheet

Upon receiving the stapling command from the printer with one sheet remaining on the compiler unit assembly, the finisher ejects the media to the stacker media bin without stapling it.

Stapling multiple size media

When sheets with different sizes and same width (example: A4L and A3S) are present on the compiler unit assembly, all the sheets are stapled and then ejected to the stacker media bin.

While if sheets with different widths are present on the compiler unit assembly, stapling is stopped when a different width is detected. Such different-width sheets are forcibly ejected to the stacker media bin.

Media limits for stapling

The number of sheets to be stapled is limited to prevent damage to the stapler.

- If the number of sheets of one set to be stapled exceeds the limit of the compiler unit assembly, the exceeding sheets are not stacked on the compiler unit assembly, and are forcibly ejected to the stacker media bin without being stapled.
- After the forcible ejection of media, if the number of following sheets of one set to be stapled exceeds the limit of the compiler unit assembly, the exceeding sheets are also ejected forcibly to the stacker media bin without being stapled.
- After that, even if the number of following sheets of one set to be stapled falls within the limit, the sheets are also ejected forcibly to the stacker media bin without being stapled.

Upper limit of compiler unit assembly media capacity when stapling: default: 50 (variable (10 to 100) by the non-volatile memory).

Stapler operation

The stapler stays at the front home position, that is, at the front staple (corner) position when the power is turned on.

The stapler starts stapling when a set of sheets to be stapled is stacked on the compiler unit assembly.

The stapler does not move during stapling in the front staple mode.

In any mode other than the front staple mode, the stapler moves to the specified position, and then perform stapling.

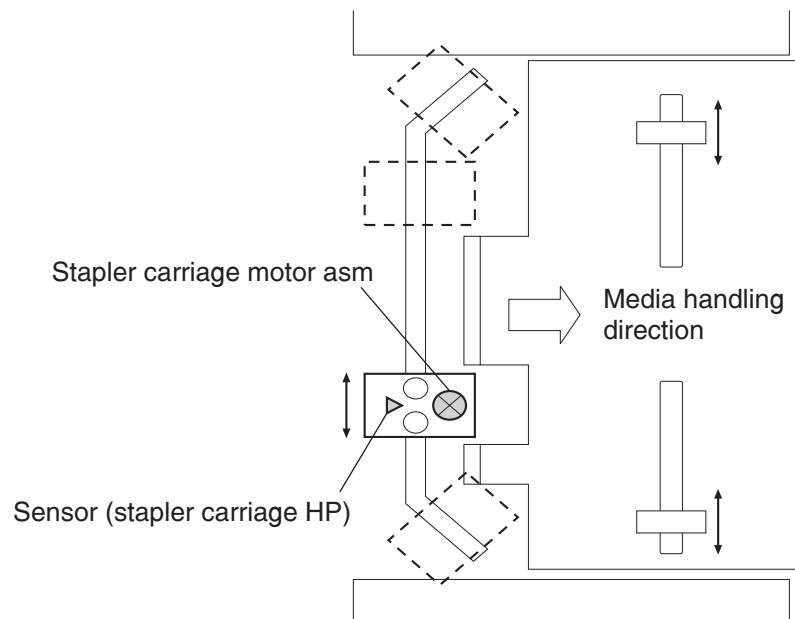

Stapler unit assembly

Stapling operation is executed by closing the stapler unit assembly.

The stapler unit assembly, containing the staple motor, the sensor (staple home), the sensor (self priming), and the sensor (low staple), is activated by the staple motor.

Forward (clockwise) rotation of the motor drives the stapler to staple a set of sheets, and returns the stapling unit to the home position.

If stapling fails, the motor rotates reversely (counterclockwise) to return the stapler unit assembly to the home position.

When staples become low, the low staple sensor detects it, and stapling stops automatically, displaying an alarm message. The message is also displayed when the staple cartridge is not installed.

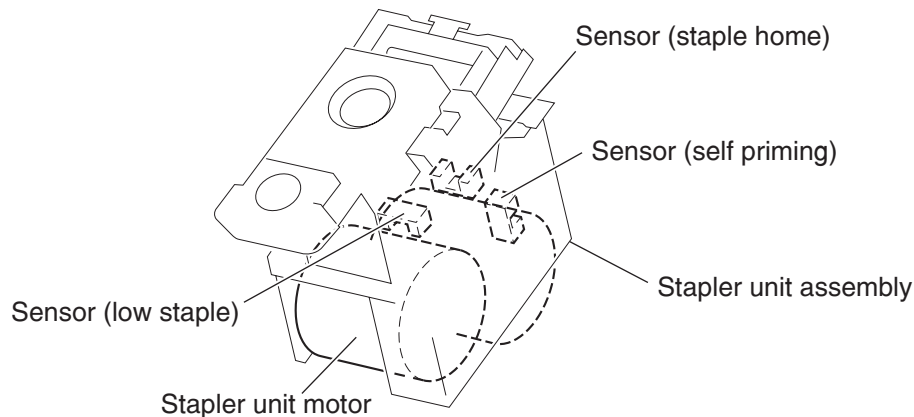

Functions of stapler sensors/motors

- Sensor (stapler carriage HP)
 - A photo-interrupter to detect the stapler home position, rear staple (corner) position, and rear staple (straight) position
 - It turns “H” (+5 V dc) (light blocking) when the stapler comes to the specified position.
- Stapler carriage motor assembly
 - A stepping motor to move the stapler unit assembly
 - Clockwise rotation of this motor moves the stapler unit assembly to the rear side, while counterclockwise rotation moves the stapler unit assembly to the front side.
- Sensor (low staple) in the stapler unit assembly
 - A photo-interrupter to detect near end of staples
 - It turns “H” (+5 V dc) when 20 staples are left.
- Sensor (self priming) in the stapler unit assembly
 - A photo-interrupter to detect that staples are at the stapler unit assembly end, and also to detect failure in stapling
 - “L” (0 V) (light blocking) when stapling is ready
- Sensor (staple home) in the stapler unit assembly
 - A photo-interrupter to detect the stapler unit assembly home position, and also to detect failure in stapling
 - This sensor also functions as a trigger to stop the staple motor.
 - It turns “L” (0 V dc) (light blocking) while the stapler unit assembly stays at the home position.

- Stapler unit motor (in the stapler unit assembly)
 - A DC motor to activate the stapler unit assembly for stapling
 - Clockwise rotation of this motor enables stapling, while counterclockwise rotation returns the stapler unit assembly.

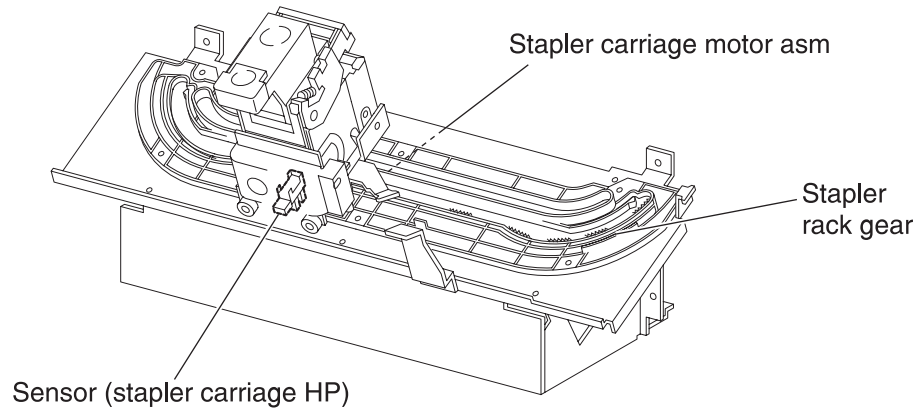

Upper media bin

Operation

The upper media bin contains the sensor (upper media bin full) to detect the media stack volume in the upper media bin.

Once the sensor detects “full stack” (500 sheets) of the upper media bin, ejection of media to the upper media bin is inhibited until “full stack” is reset.

Functions of upper media bin sensors

- Sensor (upper media exit)
 - A photo-interrupter to detect that media has come to the upper media exit roll assembly top at the exit of the upper media bin
 - When media reaches the upper media exit roll assembly top, the actuator leaves the sensing area, which turns the sensor to “H” (+5 V dc).
- Sensor (upper media bin full)
 - A reflective photo-sensor to detect the media stack volume in the upper media bin
 - It turns “H” (+5 V dc) when it detects “full stack”.

Stacker media bin

The stacker media bin goes up and down to an appropriate position according to the volume of media fed from the compiler unit assembly so as to properly stack media to “full stack”.

Operation

The stacker media bin moves to an appropriate position according to the volume of media fed from the compiler unit assembly. The sensor (stacker bin level 1) and the sensor (stacker bin level 2) detect the height of media in the stacker media bin, and the sensor (stacker bin level encoder) determines the volume of media in the tray.

When media or the stacker media bin comes between the light emitter and the photo-receiver of the sensor (stacker bin level 1) and sensor (stacker bin level 2), the emitted light is blocked, and the sensors turn “H”. The height of media or the stacker media bin is detected based on the levels of these sensors.

This sensor information is used to control the elevator motor. The motor is activated to move the stacker media bin while the sensor (stacker bin level) turns from the light blocking state to the light receiving state.

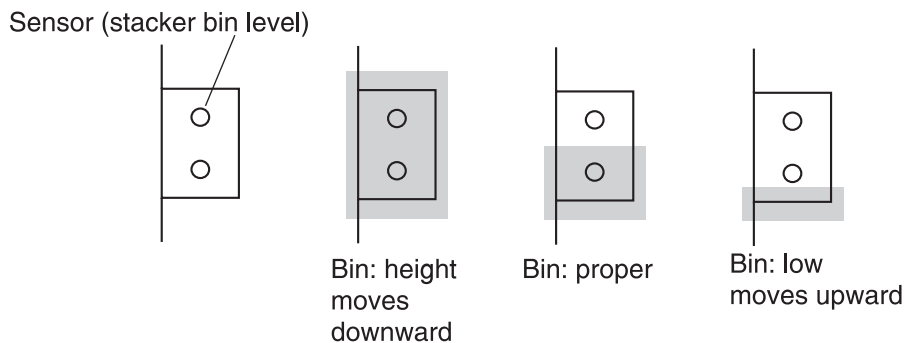

The sensor (stacker bin no media) is turned On or Off by the actuator attached to the carriage assembly right on the rear side of the finisher. In case the stacker media bin abnormally goes up above the sensor (stacker bin no media), the sensor (stacker bin upper limit) is installed above the sensor (stacker bin no media) for protection against abnormal operation.

If an operator removes media from the stacker media bin during printing, it is detected by the sensor (stacker bin level 2), and the ejection of media to the stacker media bin is inhibited. Then the elevator motor is activated to move the stacker media bin to the sensor (stacker bin level 1) sensing area. Thus, the ejection of media to the stacker media bin is restored.

If an operator removes media from the stacker media bin while printing is stopped, it is detected by the sensor (stacker bin level 2). After three seconds have passed, the elevator motor is activated to move the stacker media bin to the sensor (stacker bin level 1) sensing area. Thus, the ejection of media to the stacker media bin is restored.

The stacker media bin lowers according to the volume of media it contains. If any obstacle under the tray hinders the tray from lowering, "Stacker Lower Safety Warning" is detected, and the stacker media bin is stopped.

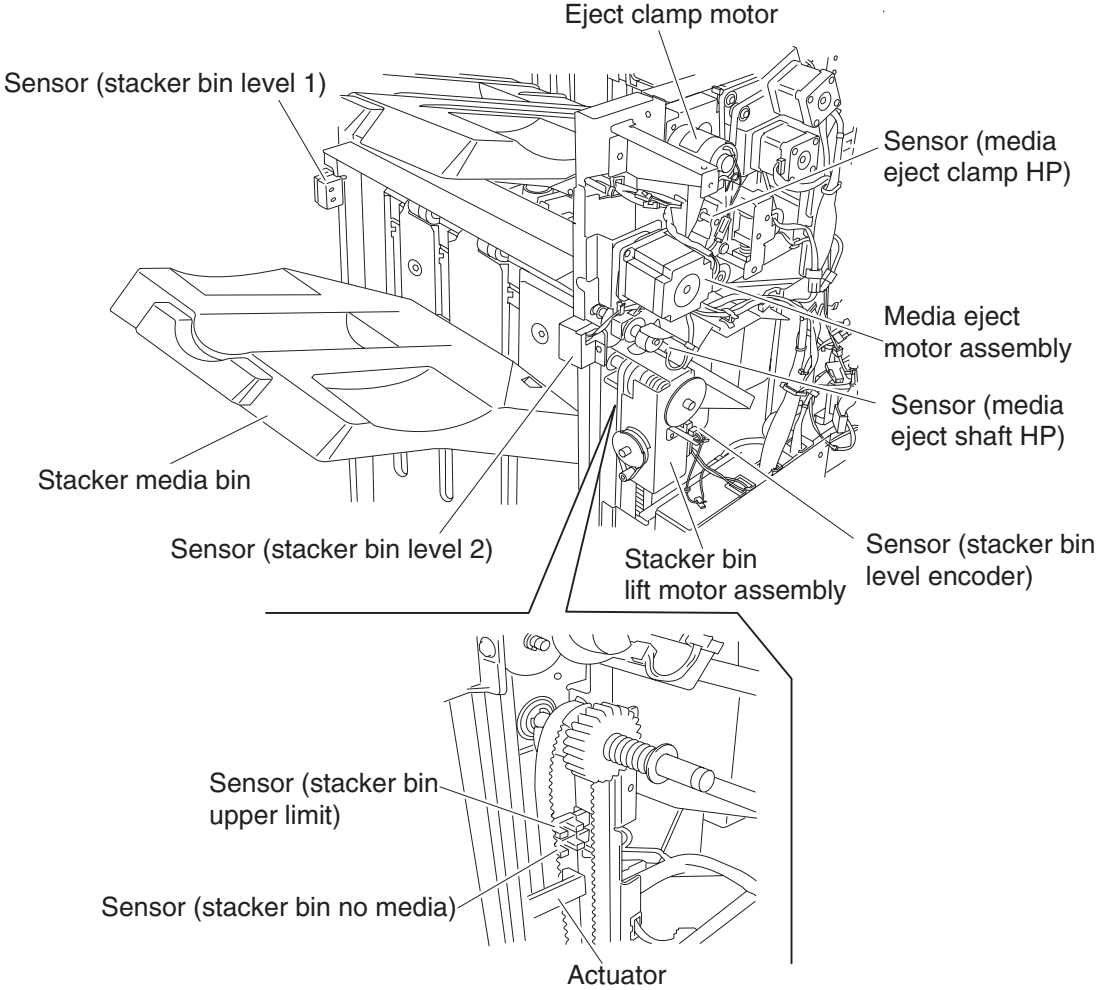

Full stack detection

“Full stack” is detected when media in the stacker media bin becomes full to prevent media jam or falling of media to the floor. The stacker media bin can stack up to approximately 3000 sheets.

The media volume in the stacker media bin is detected at every 10% (approximately 300 sheets) and notified to the Controller.

Furthermore, the stacker media bin can stack up to 200 sets (default) of stapled media.

The stacker media bin can continue to stack media until media volume reaches either of the limits above.

In the “mix stacking” mode, all the sizes are allowed until media volume of approximately 300 sheets in the stacker media bin is detected.

The “mix stacking” means one of the following cases:

- A larger (any size of media) sheet of media is stacked on a smaller sheet.
For example: A4LEF (297x210) media is stacked on A4SEF (210x297) media.
Note: When B5LEF (257x182) media is stacked on A4LEF (297x210) media, this is not “mix stacking”.
- A sheet of media of less than 11 inches is stacked in the stacker media bin with the Staple Mode changed.

Top view of finisher tray

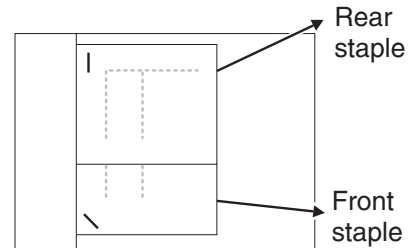

- An operator put a sheet (or sheets) when no media is remaining in the stacker media bin.
(The size and condition of media stacked in the tray are not identified.)
- Media was present in the stacker media bin when power was turned on.
(The size and condition of media stacked in the tray are not identified.)
- The finisher entered the Sleep Mode with “mix stacking” and then has exited the Sleep Mode.
- The post-processing mode has changed.

Functions of stacker media bin sensors/motors

- sensor (stacker bin level 1)
 - A pair of light emitter and photo-receiver to detect the height of media in the stacker media bin
 - This sensor is used to control the elevator motor.
 - When blocked by media or the tray, this sensor turns “H”, deciding that the stacker media bin is above the reference level.
 - To the contrary, when receiving light, this sensor turns “L”, deciding that the stacker media bin is below the reference level.
 - The “H” to “L” turning point of the sensor is defined as the reference level.
- sensor (stacker bin level 2)
 - A pair of light emitter and photo-receiver to detect the height of media in the stacker media bin (same function as sensor (stacker bin level 1))
 - This sensor is also used to control the elevator motor.
 - When blocked by media or the tray, this sensor turns “H”, deciding that the stacker media bin is above the reference level.
 - To the contrary, when receiving light, this sensor turns “L”, deciding that the stacker media bin is below the reference level.

- Sensor (stacker bin no media)
 - A photo-interrupter to detect that the stacker media bin is at the highest position, and also to detect “no media”
 - When the actuator attached to the carriage assembly right enters the sensing area, the emitted light is blocked, which turns the sensor to “H” (+5 V).
- Sensor (stacker bin upper limit)
 - A photo-interrupter to detect the stacker media bin’s abnormal elevation above the top position (sensor (stacker bin no media) position)
 - When the actuator attached to the carriage assembly right enters the sensing area, the emitted light is blocked, which turns the sensor to “H” (+5 V).
- Sensor (stacker bin level encoder)
 - A photo-interrupter to count the pulse of the Encoder attached to the Shaft-Elevator.
 - The media volume in the stacker media bin is detected based on this count.
- Stacker bin lift motor
 - A DC motor to elevate or lower the stacker media bin
 - Clockwise rotation elevates the tray, and counterclockwise rotation lowers the tray.
- Media eject motor assembly
 - A stepper motor to eject stapled or non-stapled media to the stacker media bin
 - Clockwise rotation ejects media to the stacker media bin, and counterclockwise rotation reverses the eject roll to feed the media from the punch to the compiler unit assembly.
- Media eject clamp motor

A DC motor to elevate or lower the media eject clamp when feeding media from the punch to the compiler unit assembly or from the compiler unit assembly to the stacker media bin
- Sensor (media eject clamp HP)
 - A photo-interrupter to detect the set clamp home position
 - This sensor functions as a trigger to control On/Off of the set clamp clutch.
- Media eject clutch

When this clutch is activated, it transmits the media eject motor assembly rotating power to the media eject shaft assembly.

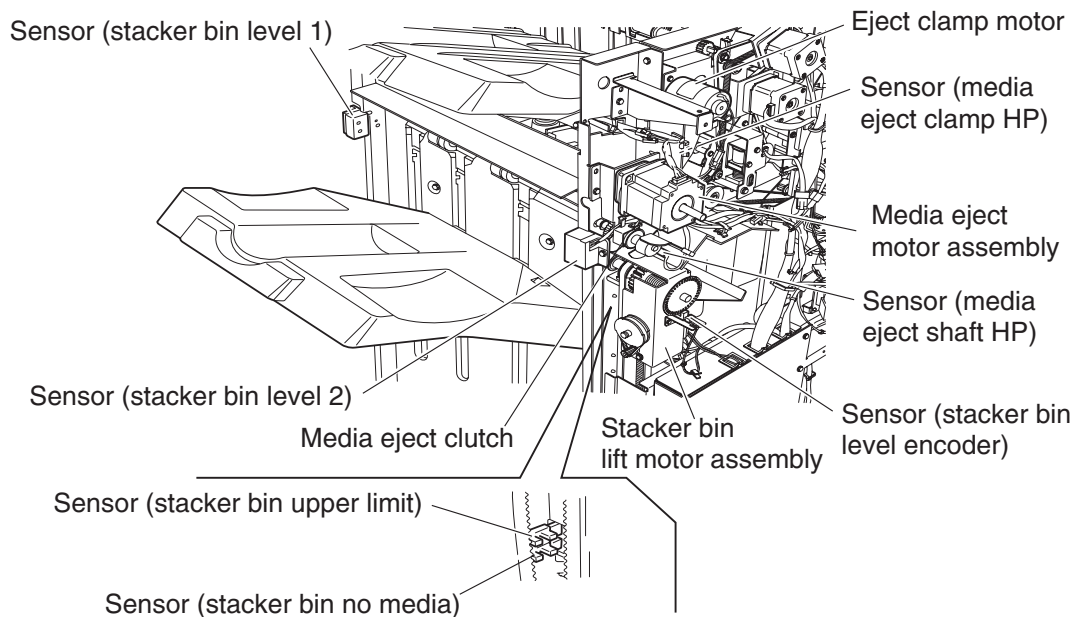

Power supply and interlock

The finisher is equipped with the following interlock switches.

- Switch (finisher front door interlock)—Turns off when the cover assembly front opens, shutting off the Interlock, +24 V dc line in the finisher.
- Switch (eject cover interlock)—Turns off when the cover eject on the right side opens, shutting off the Interlock, +24 V dc line in the finisher.

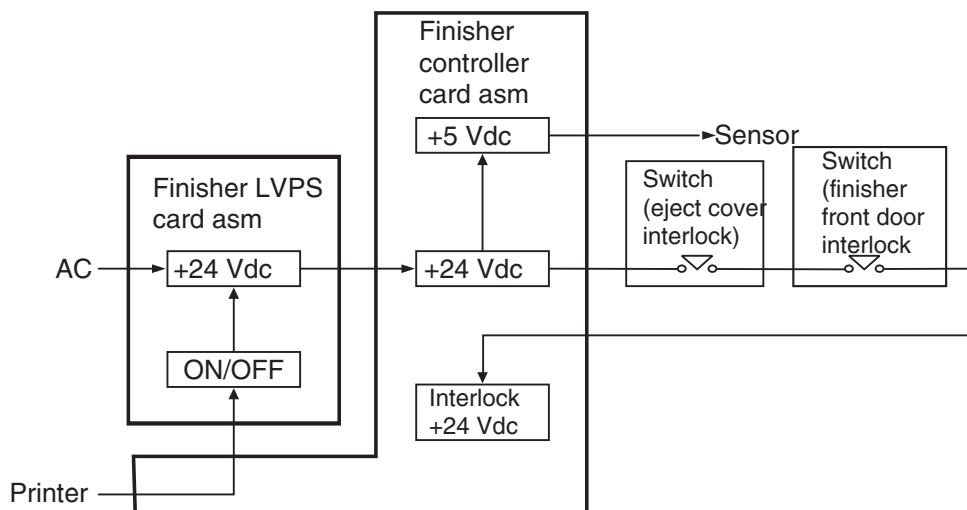
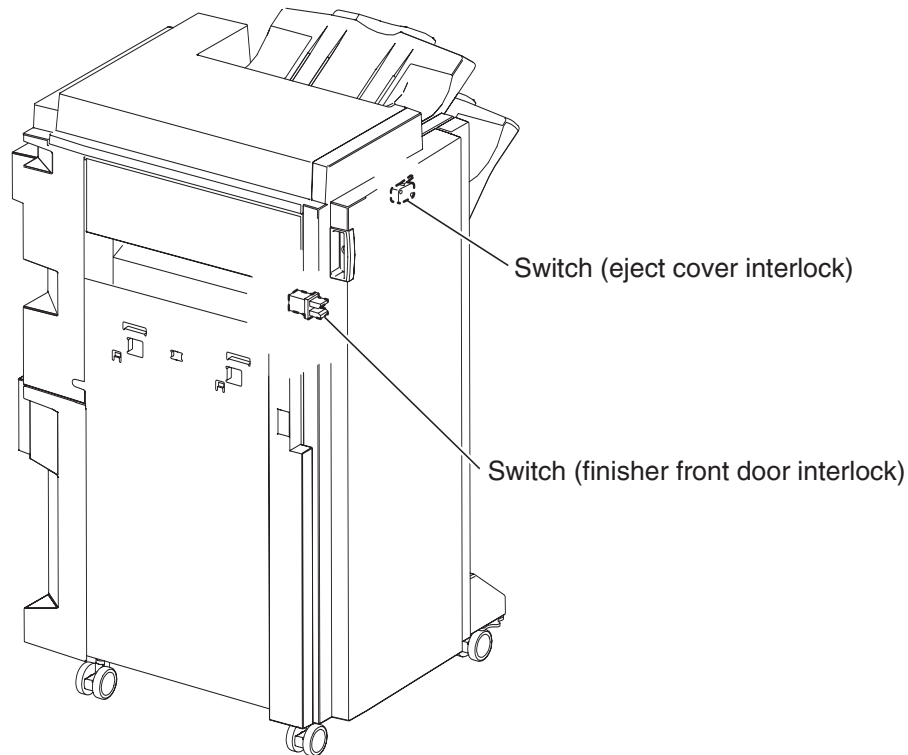

4. Repair information

Warning: Read the following before handling electronic parts.

Handling ESD-sensitive parts

Many electronic products use parts that are known to be sensitive to electrostatic discharge (ESD). To prevent damage to ESD-sensitive parts, use the following instructions in addition to all the usual precautions, such as turning off power before removing logic boards:

- Keep the ESD-sensitive part in its original shipping container (a special “ESD bag”) until you are ready to install the part into the machine.
- Make the least-possible movements with your body to prevent an increase of static electricity from clothing fibers, carpets, and furniture.
- Put the ESD wrist strap on your wrist. Connect the wrist band to the system ground point. This discharges any static electricity in your body to the machine.
- Hold the ESD-sensitive part by its edge connector shroud (cover); do not touch its pins. If you are removing a pluggable module, use the correct tool.
- Do not place the ESD-sensitive part on the machine cover or on a metal table; if you need to put down the ESD-sensitive part for any reason, first put it into its special bag.
- Machine covers and metal tables are electrical grounds. They increase the risk of damage because they make a discharge path from your body through the ESD-sensitive part. (Large metal objects can be discharge paths without being grounded.)
- Prevent ESD-sensitive parts from being accidentally touched by other personnel. Install machine covers when you are not working on the machine, and do not put unprotected ESD-sensitive parts on a table.
- If possible, keep all ESD-sensitive parts in a grounded metal cabinet (case).
- Be extra careful in working with ESD-sensitive parts when cold-weather heating is used, because low humidity increases static electricity.

Removal procedures



CAUTION: Remove the power cord from the printer or electrical outlet before you connect or disconnect any cable or electronic board or assembly for personal safety and to prevent damage to the printer. Disconnect any connections between the printer and PCs/peripherals.

Note: Some removal procedures require removing cable ties. You must replace cable ties during reassembly to avoid pinching wires, obstructing the paper path, or restricting mechanical movement.

Bridge unit assembly removal

1. Release the hook securing the bridge unit hookup cover (A) to the finisher.
2. Remove the bridge unit hookup cover (A).

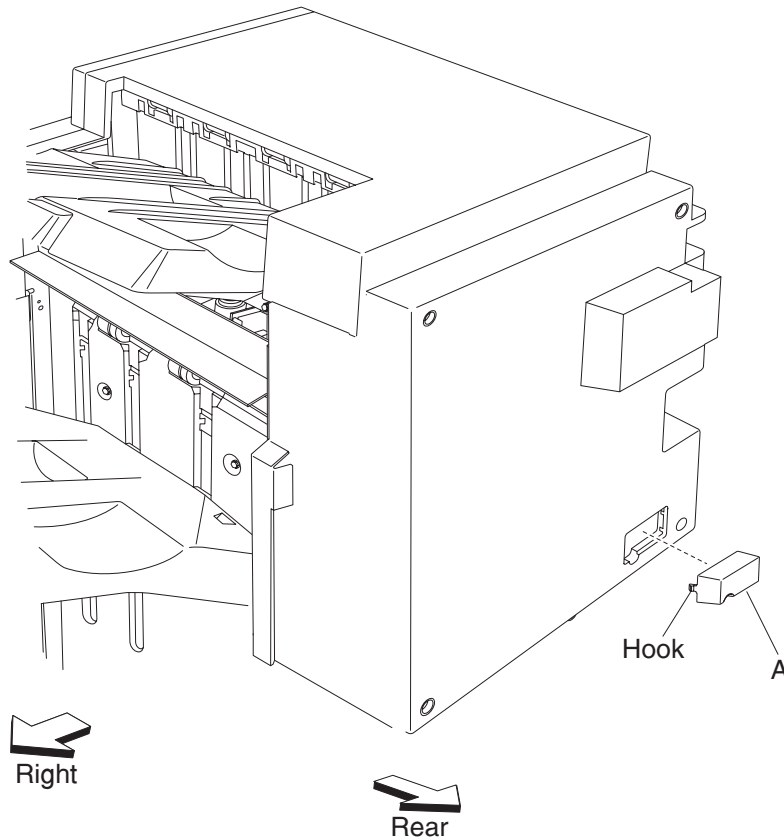

3. Remove the finisher from the printer. See **“Finisher removal” on page 4-4.**
4. Remove the two screws securing the bridge unit assembly (B) to the printer.

5. Remove the bridge unit assembly (B) from the printer.

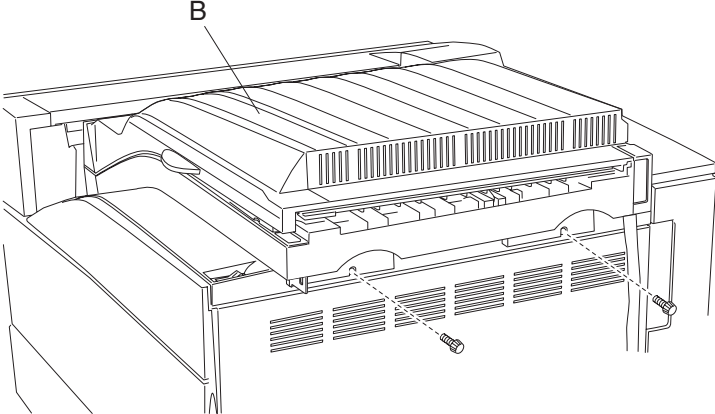

Finisher removal

1. Disconnect the finisher power cord and the finisher connection cable from the rear of the printer.
2. Release the hook securing the bridge unit hookup cover (A) to the finisher.

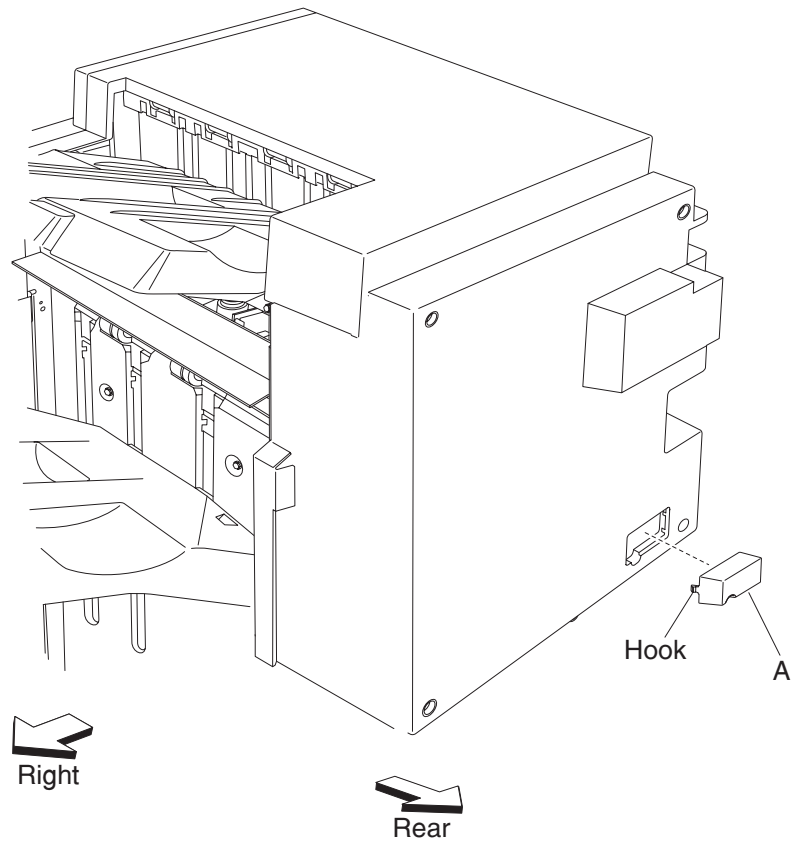

3. Remove the bridge unit hookup cover (A).
4. Disconnect the bridge unit connection from the finisher.

5. Open the finisher front door assembly (B) on the front of the finisher.
6. Pull the finisher docking latch assembly (C) outward in the direction of the arrow, and pull the finisher away from the printer.

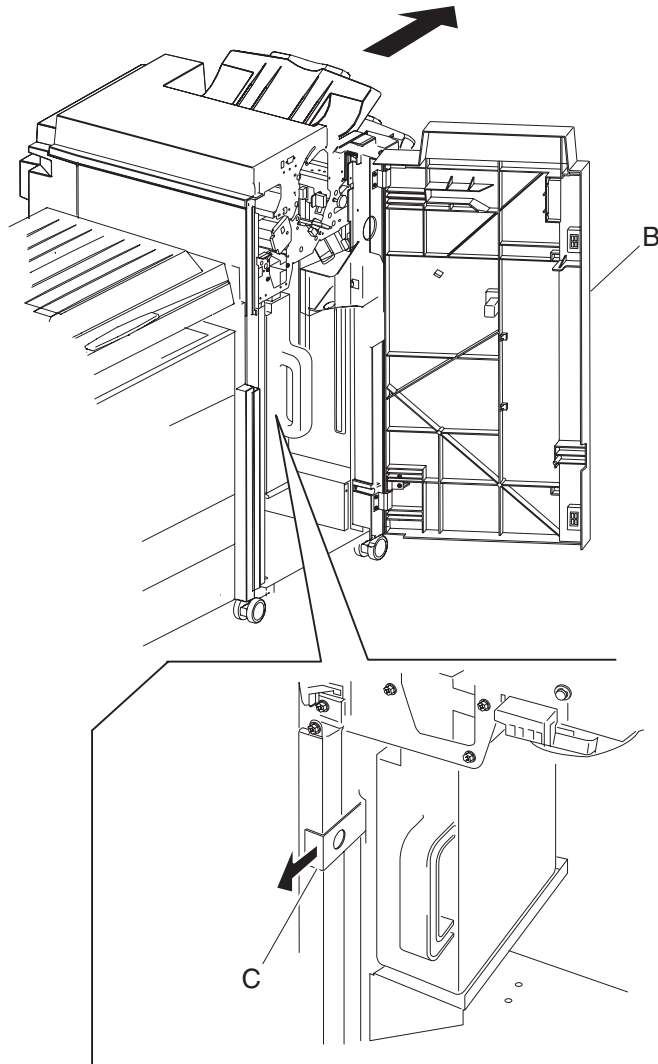

7. Close the finisher front door assembly.

8. Remove the two screws securing the finisher docking bracket (D) to the printer.
9. Remove the finisher docking bracket (D).

Replacement note: When docking the finisher to the printer, make sure the boss on the finisher docking bracket (D) is inserted into the hole on the finisher docking latch assembly (C). The finisher should be firmly locked into position.

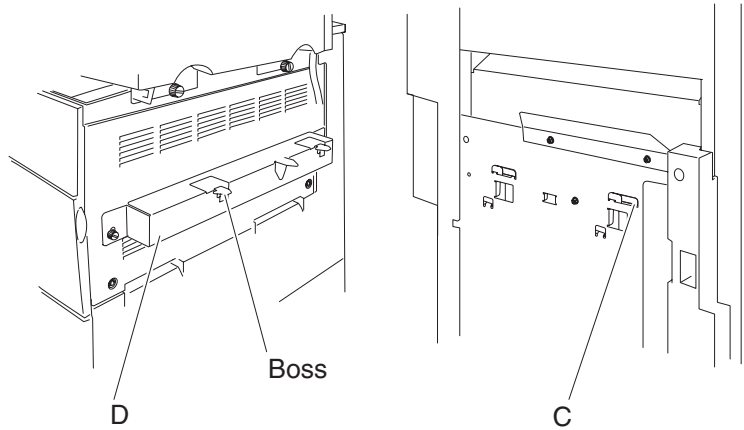

Bridge unit rear cover removal

1. Remove the bridge unit assembly. See **“Bridge unit assembly removal” on page 4-2.**
2. Remove the two screws securing the bridge unit rear cover (A) to the bridge unit assembly (B).

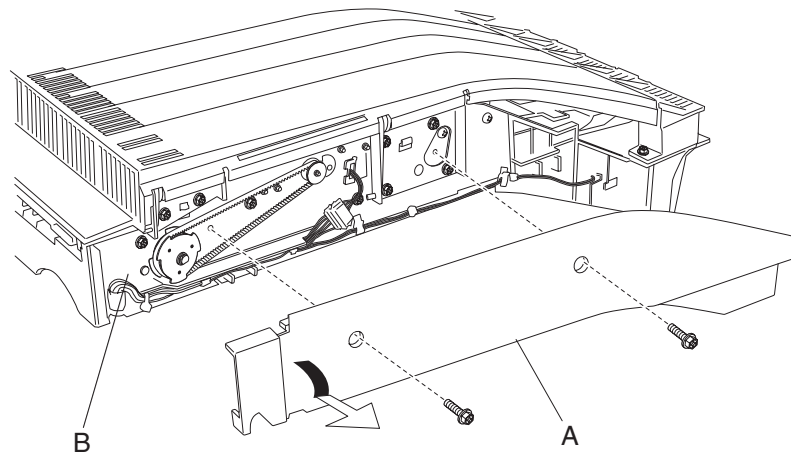

3. Remove the bridge unit rear cover (A).

Bridge unit top cover assembly removal

1. Remove the bridge unit rear cover. See **“Bridge unit rear cover removal”** on page 4-6.
2. Open the bridge unit top cover assembly (A).
3. Remove the six screws securing the bridge unit top cover assembly (A) to the bridge unit assembly (B).

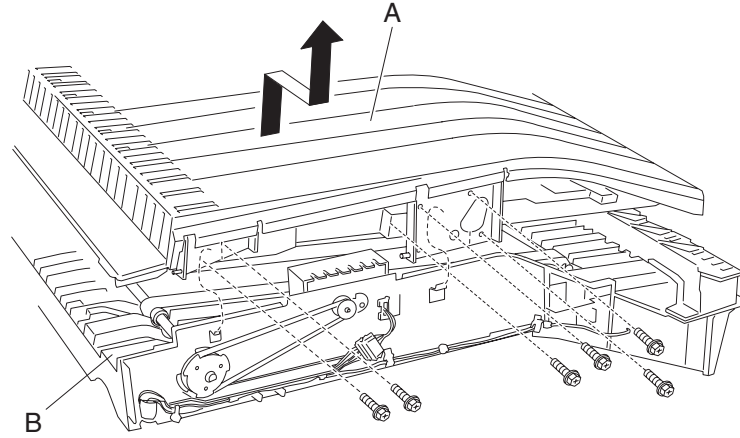

4. Lift the bridge unit top cover assembly (A) upward in the direction of the arrow.
5. Remove the bridge unit top cover assembly (A).

Bridge unit drive belt and bridge unit drive pulley removal

1. Remove the bridge unit rear cover. See **“Bridge unit rear cover removal”** on page 4-6.
2. Remove the e-clip with a prying tool securing the bridge unit drive pulley (A) to the bridge unit assembly (B).
3. Remove the bridge unit drive pulley (A) and the bridge unit drive belt (C) from the bridge unit assembly (B).

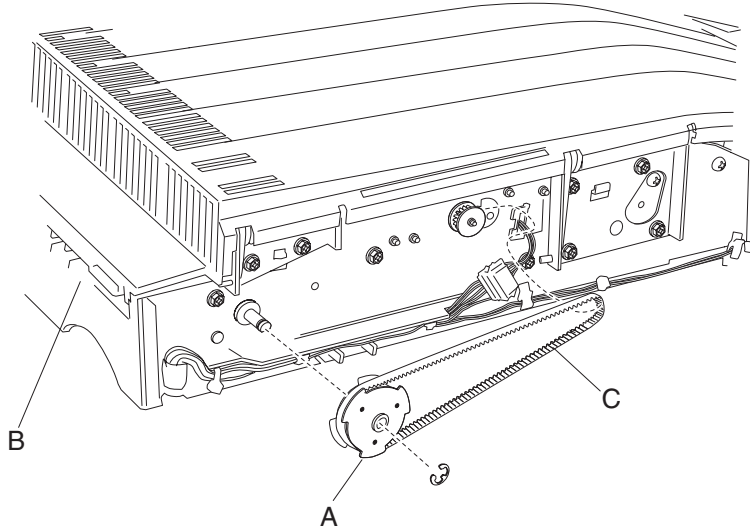

Replacement note: Make sure to install the bridge unit drive pulley (A) to the bridge unit assembly in the direction shown.

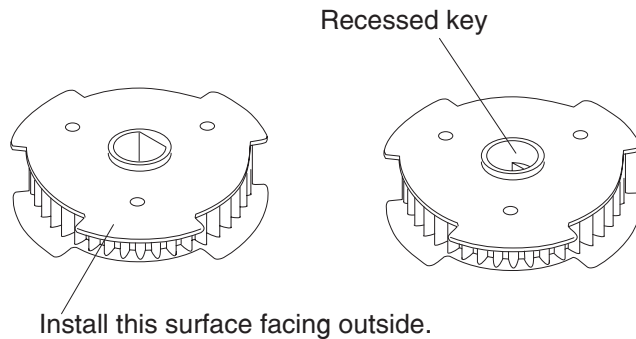

Bridge unit right shaft assembly removal

1. Remove the bridge unit rear cover. See **“Bridge unit rear cover removal”** on page 4-6.
2. Remove the bridge unit transport belt and bridge unit drive pulley. See **“Bridge unit drive belt and bridge unit drive pulley removal”** on page 4-8.
3. Remove the 6 mm bushing (A) from the bridge unit right shaft assembly (B).
4. Open the bridge unit top cover assembly (C).

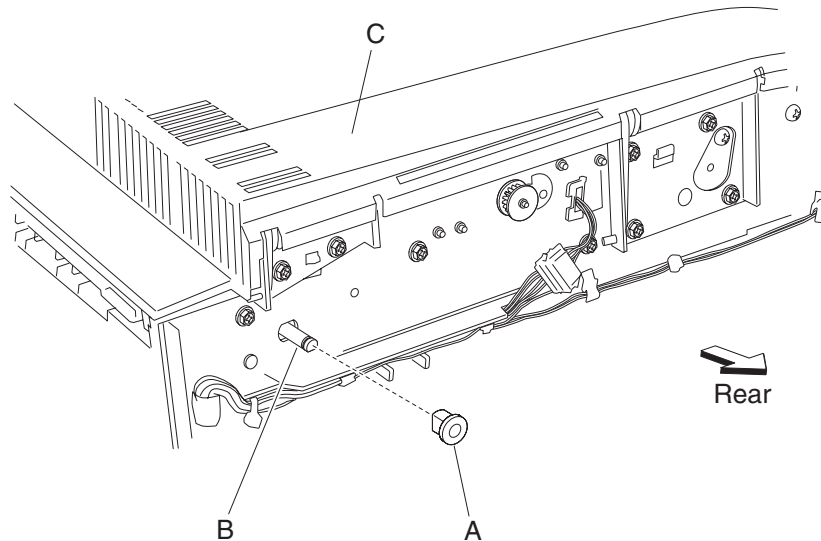

5. Use a prying tool to remove the e-clip securing the 6 mm bushing (D) to the bridge unit assembly.
6. Remove the 6 mm bushing (D).
7. Move the bridge unit right shaft assembly (B) toward the right as shown.
8. Remove the bridge unit right shaft assembly (B) from the two transport belts (E).
9. Remove the bridge unit right shaft assembly (B).

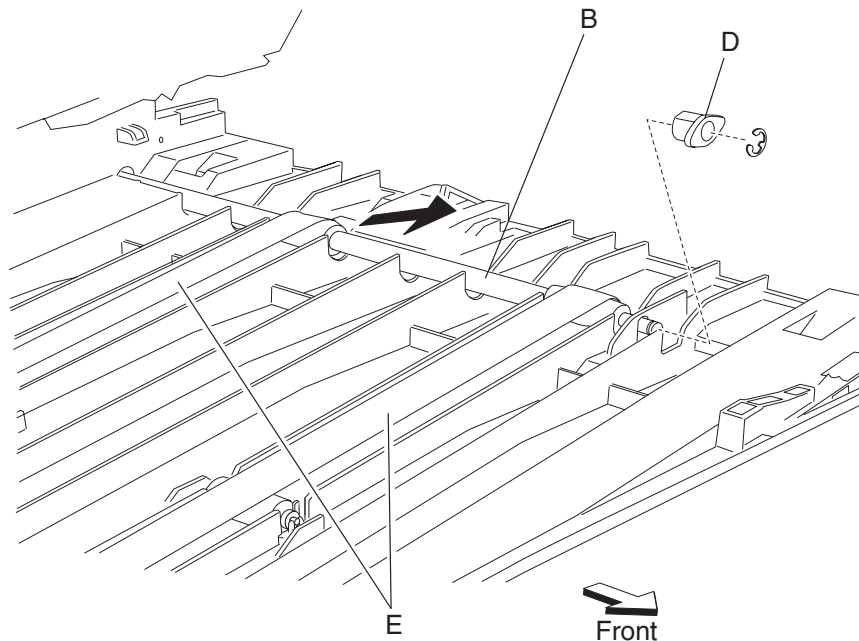

Bridge unit left shaft assembly removal

1. Open the bridge unit top cover assembly.
2. Use a prying tool to remove the front e-clip securing the 4 mm ball bearing (A) to the bridge unit left shaft (B).

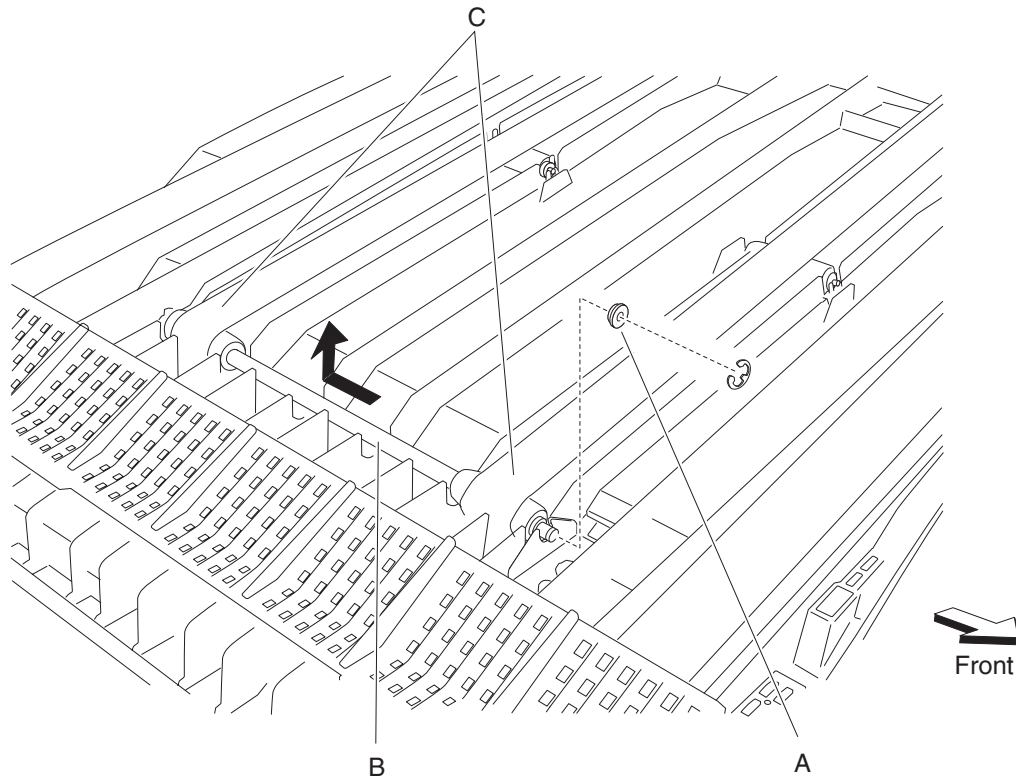

3. Move the bridge unit left shaft (B) rearward as shown.
4. Remove the bridge unit left shaft (B) from the two transport belts (C).
5. Remove the bridge unit left shaft (B).
6. Remove the other e-clip securing the 4 mm ball bearing (A) on the other end of the shaft.
7. Remove the second 4 mm ball bearing (A) from the bridge unit left shaft.

Bridge unit idler rolls removal

1. Open the bridge unit top cover assembly.
2. Remove the bridge unit left shaft assembly. See **“Bridge unit left shaft assembly removal” on page 4-10.**
3. Move the two transport belts (A) away from the two bridge unit idler rolls (B).
4. Lift the two bridge unit idler rolls upward to release them from the bridge unit assembly (C).
5. Remove the bushings (D) from the bridge unit idler rolls.

Replacement note: When replacing the bridge unit idler rolls, make sure the bushings are installed as shown.

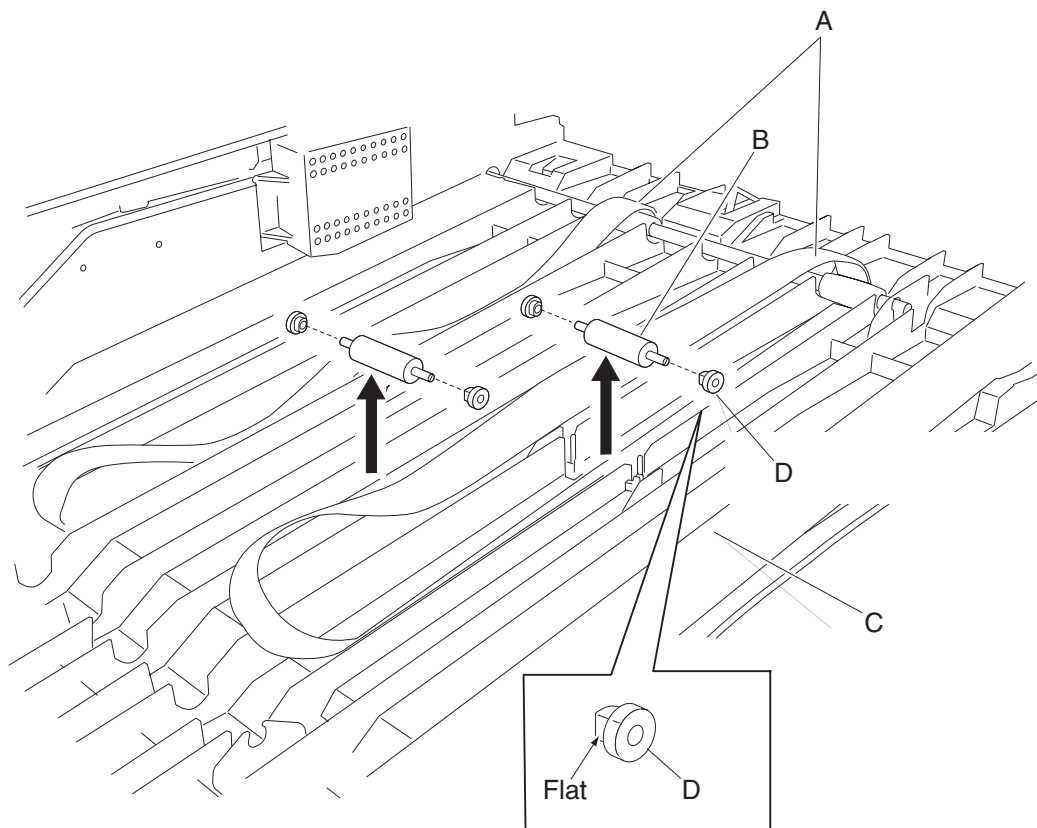

Bridge unit transport belt removals

1. Remove the bridge unit rear cover. See **“Bridge unit rear cover removal”** on page 4-6.
2. Open the bridge unit top cover assembly.
3. Remove the bridge unit right shaft assembly. See **“Bridge unit right shaft assembly removal”** on page 4-9.
4. Remove the bridge unit left shaft assembly. See **“Bridge unit left shaft assembly removal”** on page 4-10
5. Remove the bridge unit idler rolls. See **“Bridge unit idler rolls removal”** on page 4-11.
6. Remove the transport belts (A) from the bridge unit assembly (B).

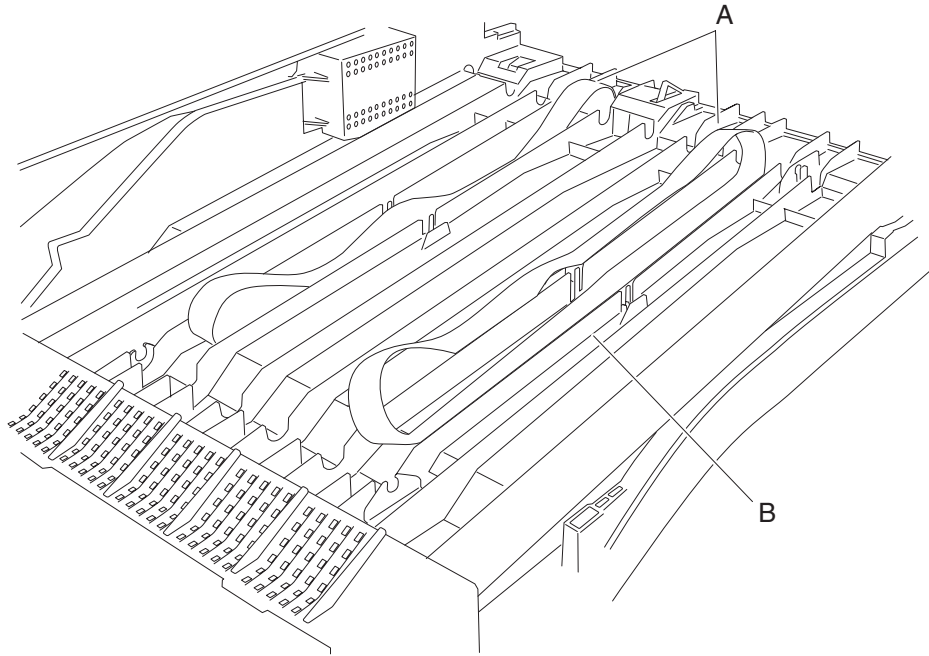

Bridge unit drive motor assembly removal

1. Remove the bridge unit rear cover. See **“Bridge unit rear cover removal”** on page 4-6.
2. Remove the bridge unit drive belt. See **“Bridge unit drive belt and bridge unit drive pulley removal”** on page 4-8.
3. Disconnect the connector from the bridge unit drive motor (A).

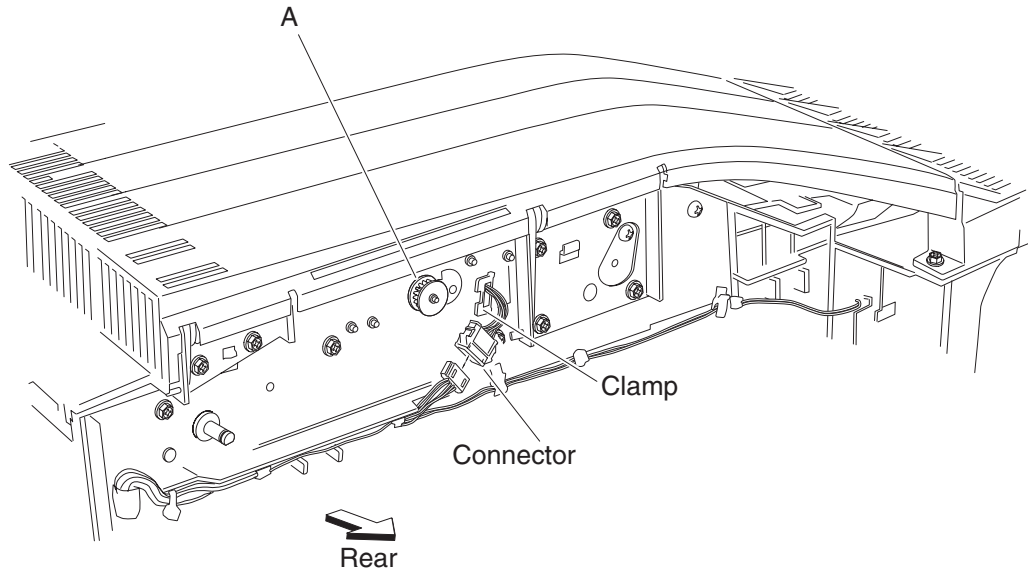

4. Release the harness from the clamp.
5. Open the bridge unit top cover assembly.
6. Remove the two screws securing the cover (B) from the bridge unit assembly (C).
7. Remove the cover (B).
8. Remove the two screws securing the bridge unit drive motor (A) to the bridge unit assembly (C).

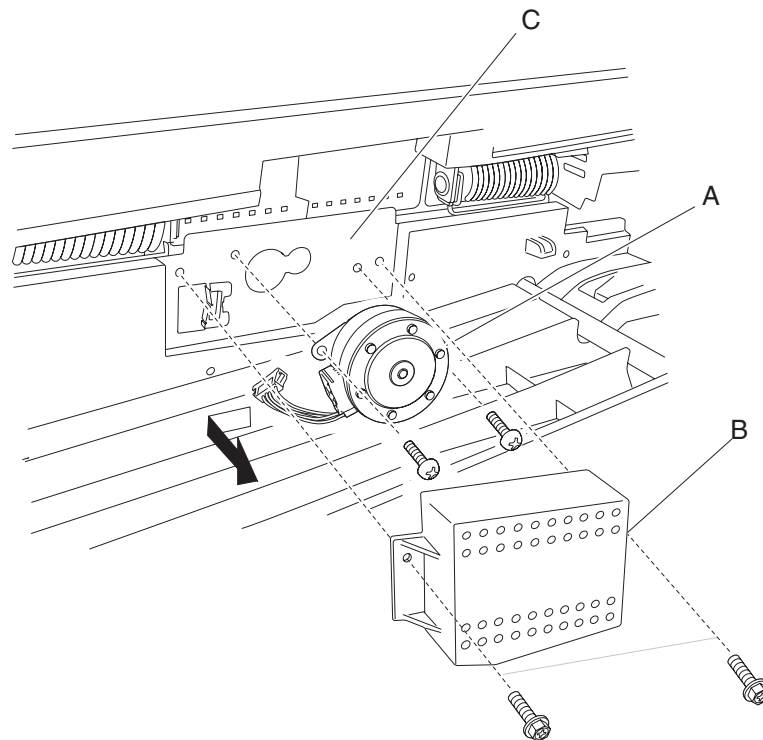

9. Remove the bridge unit drive motor (A).

Bridge unit entrance guide removal

1. Remove the bridge unit rear cover. See **“Bridge unit rear cover removal”** on page 4-6.
2. Open the bridge unit top cover assembly.
3. Remove the two screws securing the bridge unit entrance guide (A) to the bridge unit assembly (B).

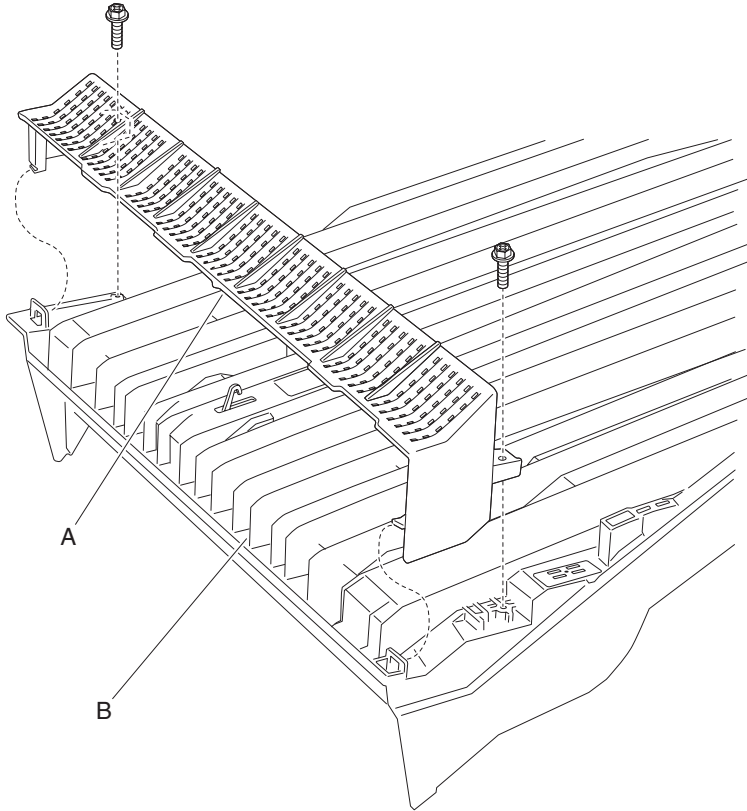

4. Remove the bridge unit entrance guide (A).

Sensor (bridge unit top cover interlock) removal

1. Remove the bridge unit assembly. See **“Bridge unit assembly removal”** on page 4-2.
2. Place the bridge unit assembly upside down.
3. Remove the screw securing the bracket (A) to the bridge unit assembly (B).
4. Disconnect the cable from the sensor (bridge unit top cover interlock) (C).

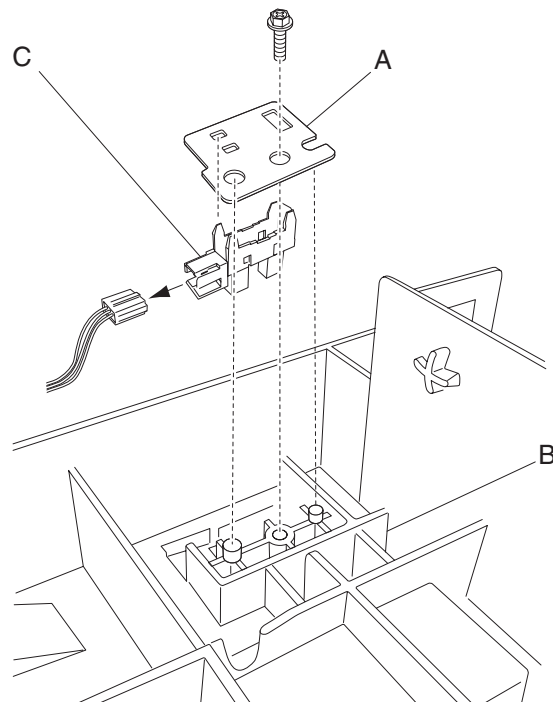
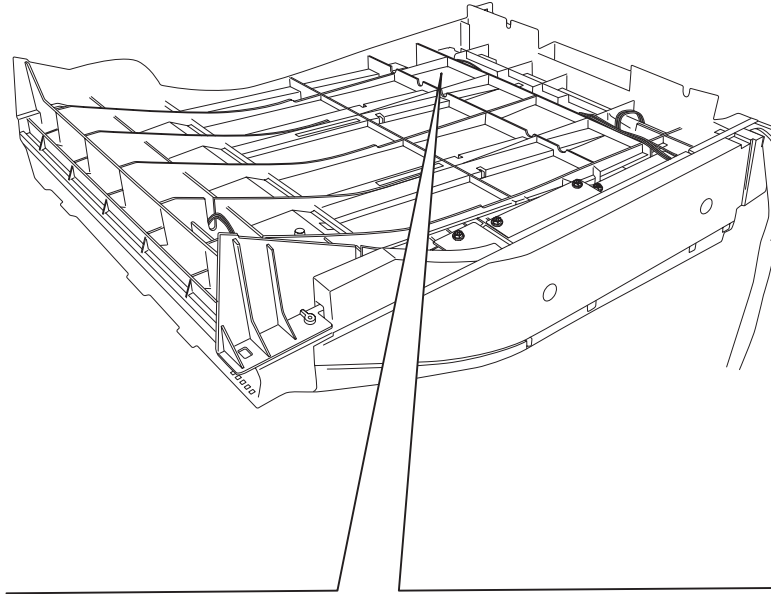

5. Release the hooks securing the sensor (bridge unit top cover interlock) (C) to the bracket (A).
6. Remove the sensor (bridge unit top cover interlock) (C).

Sensor (bridge unit media entrance) removal

1. Remove the bridge unit assembly. See **“Bridge unit assembly removal”** on page 4-2.
2. Place the bridge unit assembly upside down.
3. Remove the screw securing the bracket (A) to the bridge unit assembly (B).
4. Disconnect the connector from the sensor (bridge unit media entrance) (C).

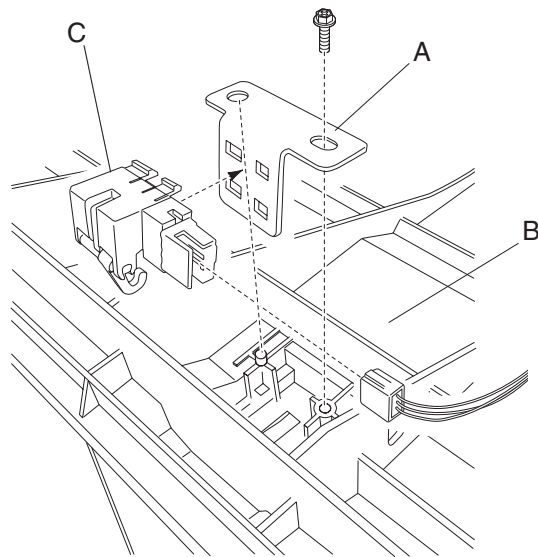
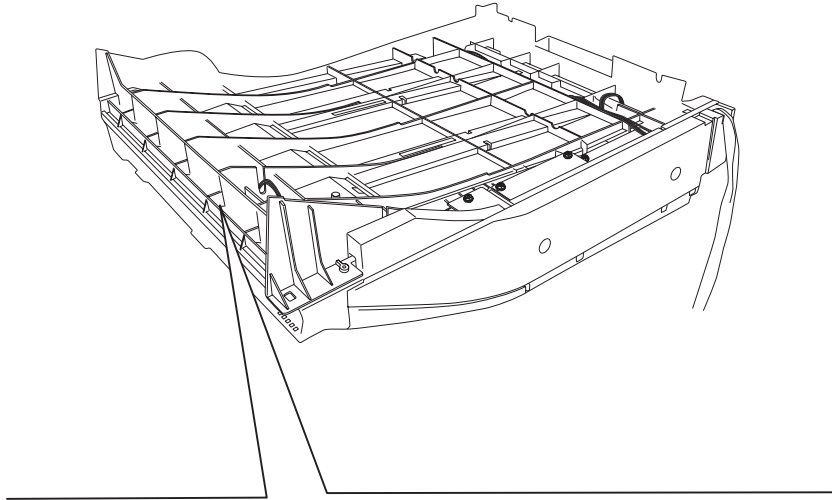

5. Release the hooks securing the sensor (bridge unit media entrance) (C) to the bracket (A).
6. Remove the sensor (bridge unit media entrance) (C).

Sensor (bridge unit media exit) removal

1. Remove the bridge unit assembly. See **“Bridge unit assembly removal”** on page 4-2.
2. Place the bridge unit upside down.
3. Remove the screw securing the bracket (A) to the bridge unit (B).

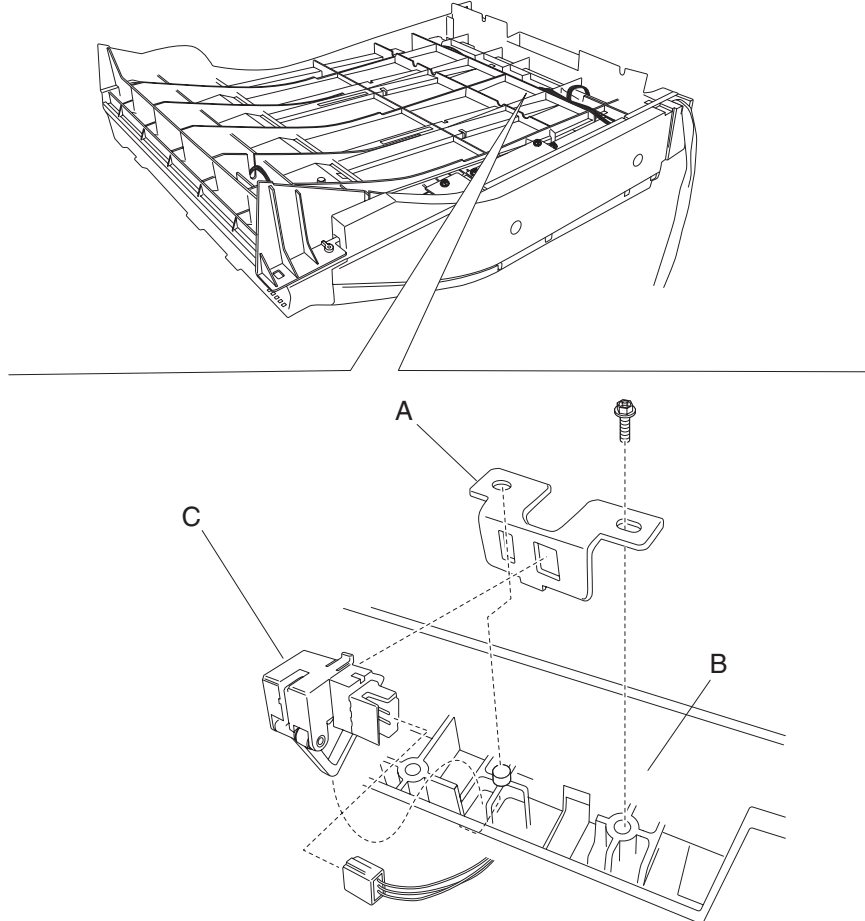

4. Disconnect the connector from the sensor (bridge unit media exit) (C).
5. Release the hooks securing the sensor (bridge unit media exit) (C) to the bracket (A).
6. Remove the sensor (bridge unit media exit) (C).

Bridge unit pinch roller removal

1. Open the bridge unit top cover assembly (A).
2. Remove the six bridge unit pinch rollers (B) by gently pulling them out of the bridge unit top cover assembly.
3. Remove the six springs (C).

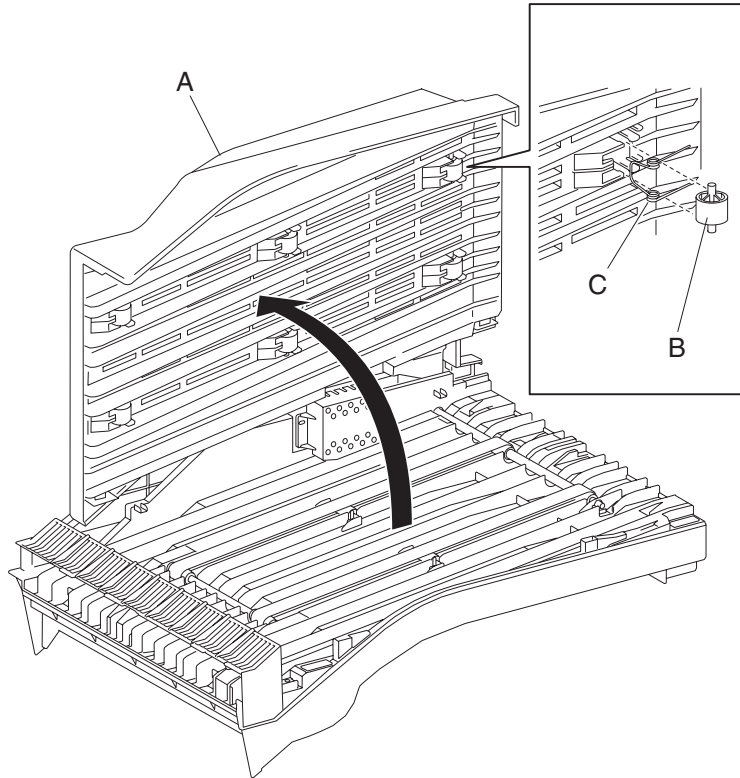

Top cover removal

1. Open the finisher front door assembly.
2. Remove the rear upper cover. See **“Rear upper cover removal” on page 4-24.**
3. Remove the upper media bin assembly. See **“Upper media bin assembly removal” on page 4-20.**
4. Remove the four screws securing the top cover (A) to the finisher.

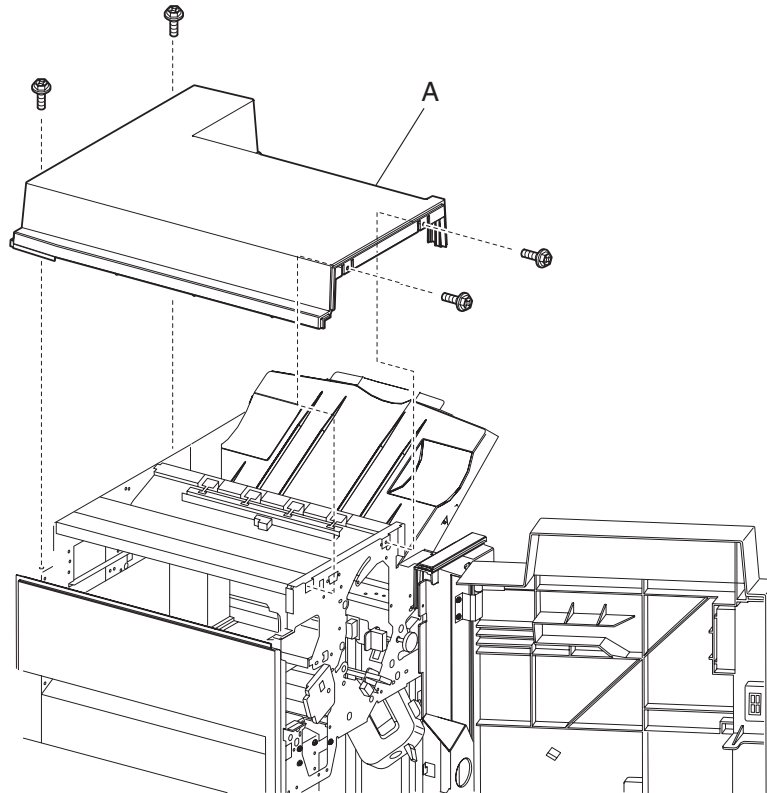

5. Remove the top cover (A).

Upper media bin assembly removal

1. Loosen the two screws securing the upper media bin assembly (A) to the finisher.

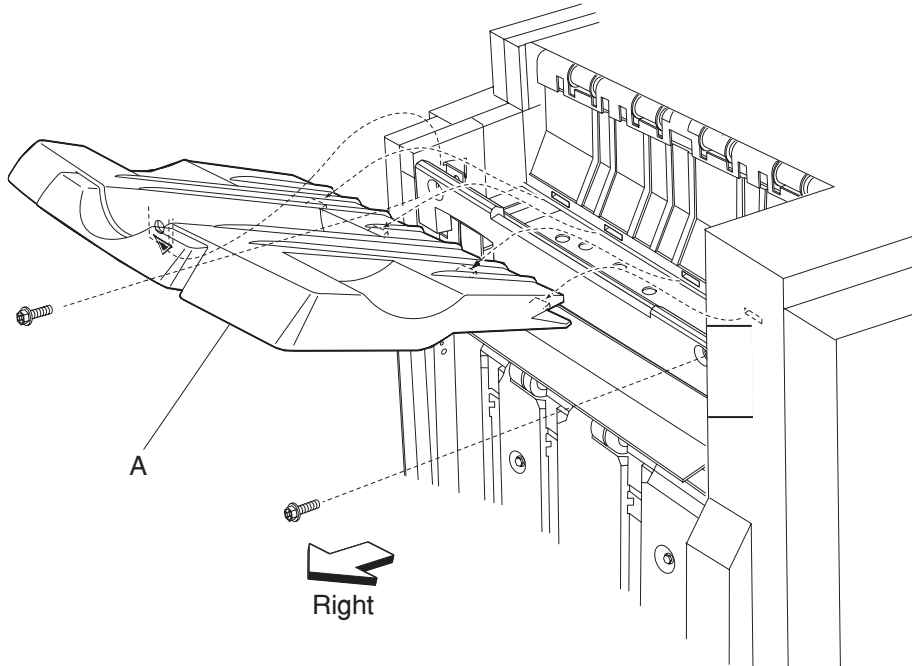

2. Lift the upper media bin assembly (A) upward in the direction of the arrow.
3. Remove the upper media bin assembly (A).

Right eject cover removal

1. Remove the finisher front door assembly. See **“Finisher front door assembly removal”** on page 4-27.
2. Remove the rear upper cover. See **“Rear upper cover removal”** on page 4-24.
3. Remove the two screws securing the right eject cover (A) to the finisher.

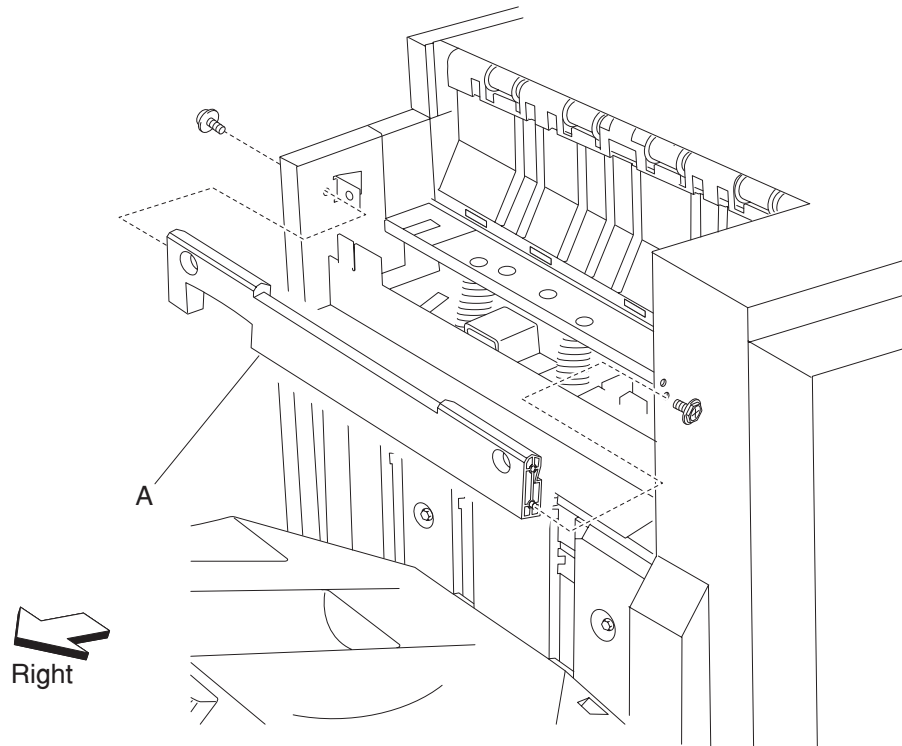

4. Remove the right eject cover (A).

Stacker media bin assembly removal

1. Release the two hooks securing the stacker media bin assembly (A) to the finisher.

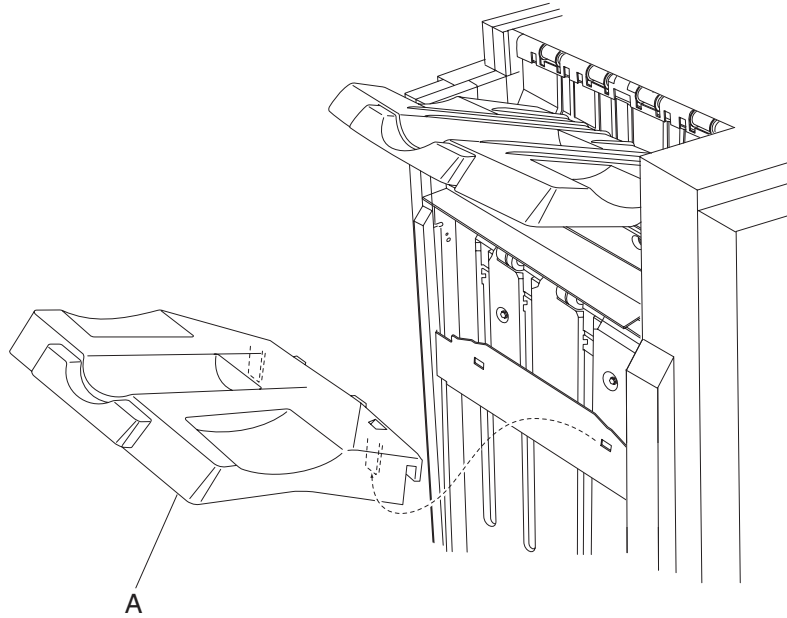

2. Lift the stacker media bin assembly (A) upward.
3. Remove the stacker media bin assembly. (A).

Right lower low voltage power supply (LVPS) cover removal

1. Remove the two screws securing the right lower LVPS cover (A) to the finisher.
2. Remove the right lower LVPS cover (A).

Replacement note: Make sure to put the power cord (B) into the notch on the right lower LVPS cover (A).

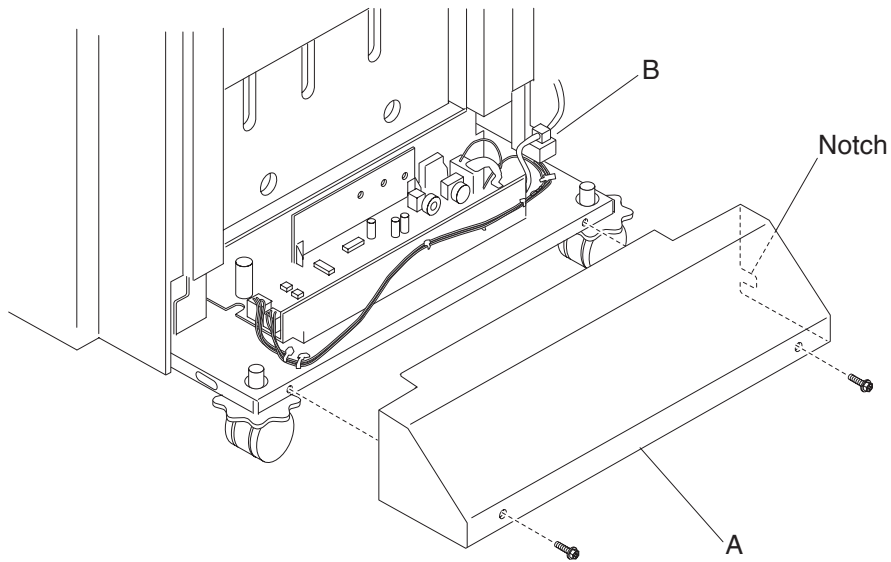

Rear lower cover removal

1. Remove the rear upper cover. See **“Rear upper cover removal”** on page 4-24
2. Remove the four screws securing the rear lower cover (A) to the finisher.

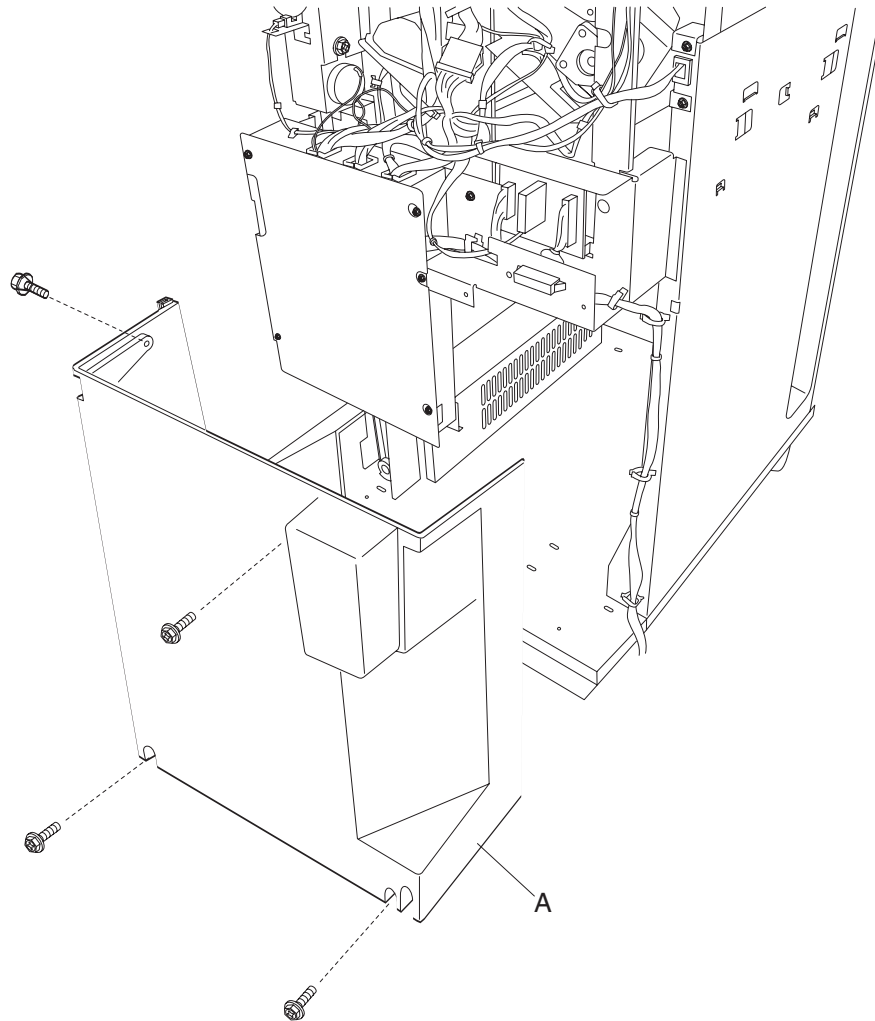

3. Remove the rear lower cover (A).

Rear upper cover removal

1. Release the hook of the bridge unit hookup cover (A) to the finisher.
2. Disconnect the bridge unit harness from the finisher.
3. Remove the four screws securing the rear upper cover (B) to the finisher.

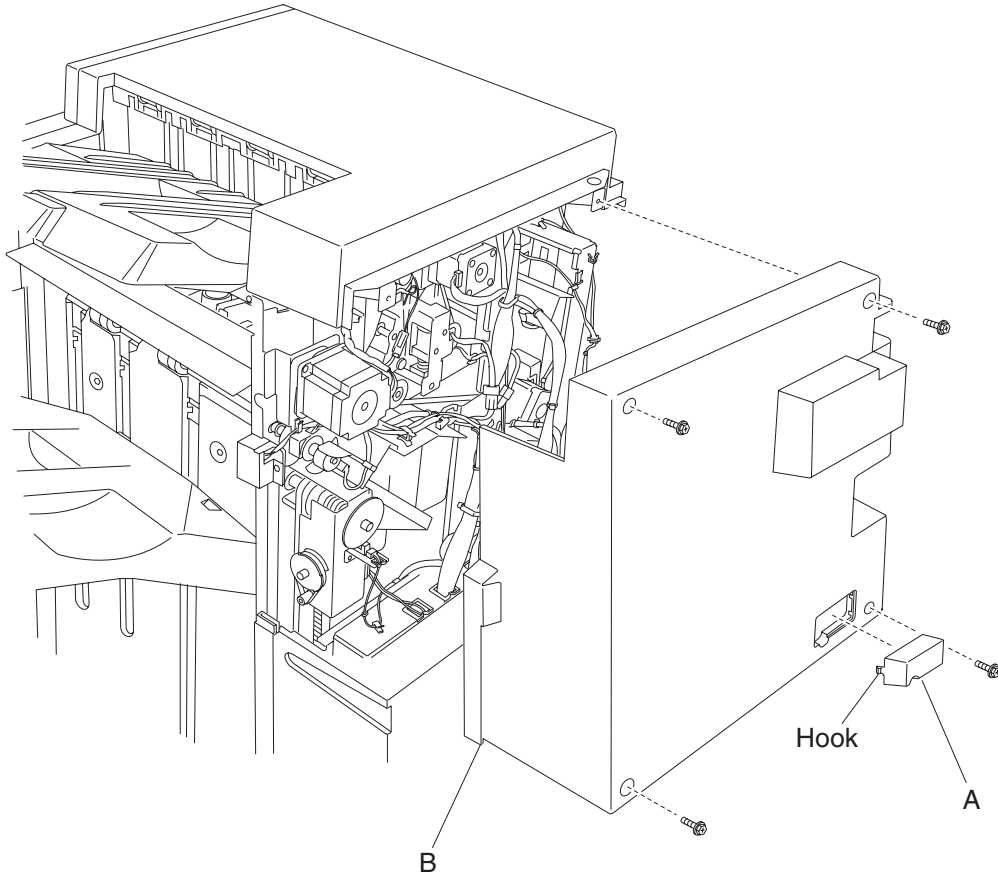

4. Remove the rear upper cover (B).

Upper media bin front cover removal

1. Remove the finisher front door assembly. See **“Finisher front door assembly removal”** on page 4-27.
2. Remove the upper media bin assembly. See **“Upper media bin assembly removal”** on page 4-20.
3. Remove the two screws securing the upper media bin front cover (A).

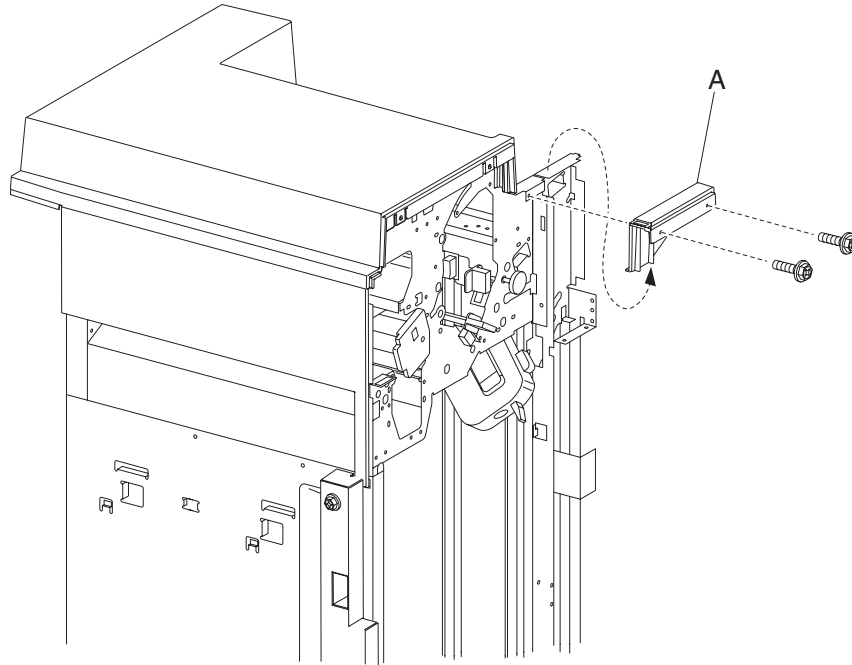

4. Remove the upper media bin front cover (A).

Switch (finisher front door interlock) removal

1. Open the finisher front door assembly.
2. Remove the rear upper cover. See **“Rear upper cover removal”** on page 4-24.
3. Remove the punch waste box (A).
4. Remove the three screws in the front securing the punch waste chute (B).
5. Gently pull down the punch waste chute (B) to gain better access to the switch (finisher front door interlock) (C).
6. Disconnect the connector from the switch (finisher front door interlock) (C).

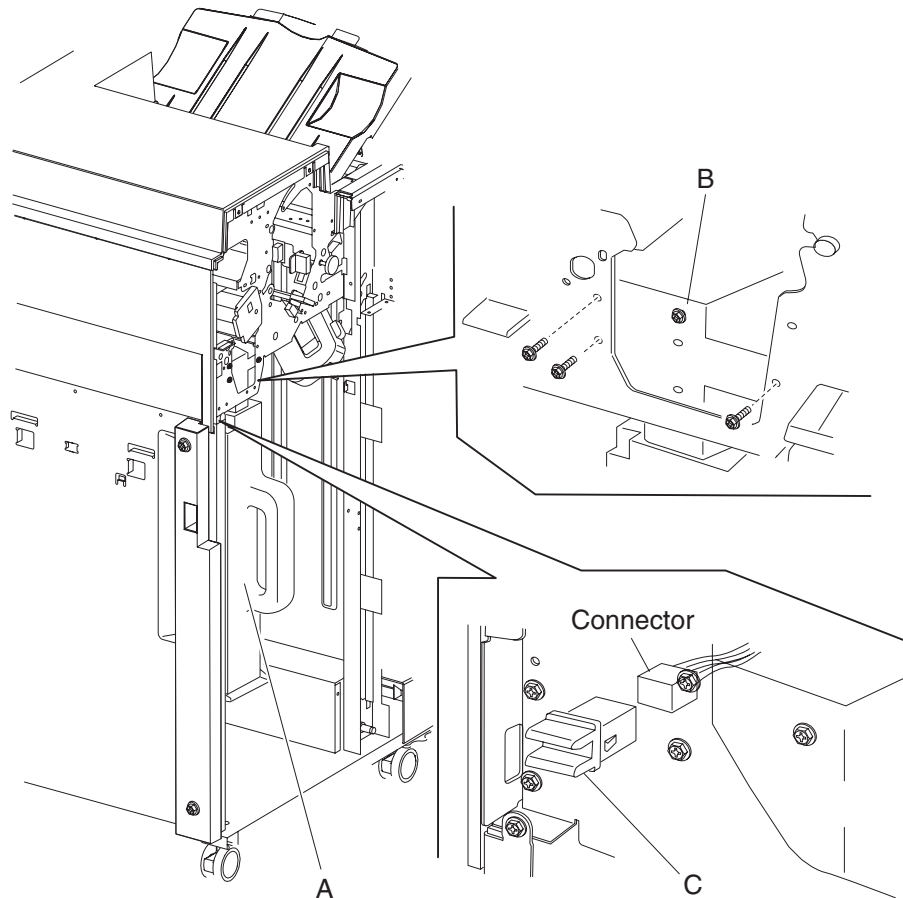

7. Release the hooks securing the switch (finisher front door interlock) (C) to the finisher.
8. Remove the switch (finisher front door interlock) (C).

Finisher front door assembly removal

1. Open the finisher front door assembly (A).
2. Remove the three screws securing the finisher front door assembly.
3. Remove the finisher front door assembly.

Replacement note: Make sure the actuator molded in the finisher front door assembly properly engages the switch (finisher front door interlock) (B). The two magnetic catches (C) should properly engage the finisher.

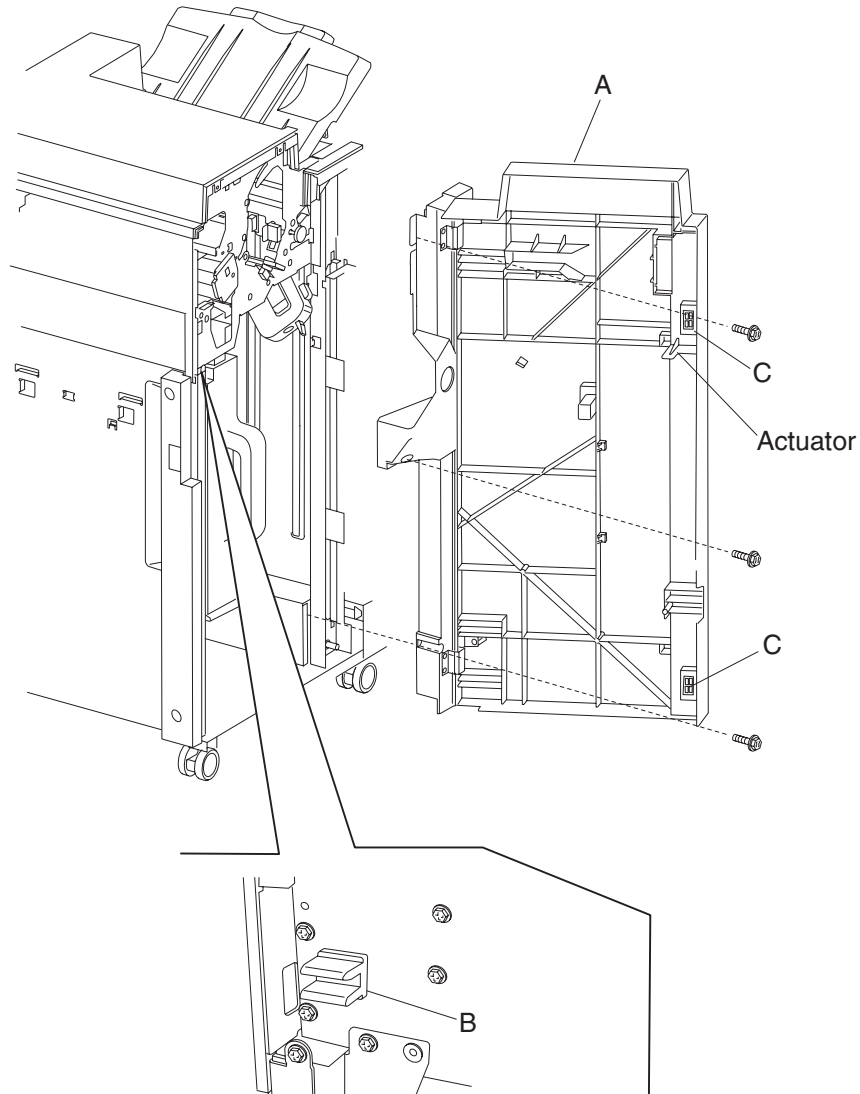

Left lower cover removal

1. Open the finisher front door assembly.
2. Remove the two screws securing the left lower cover (A).

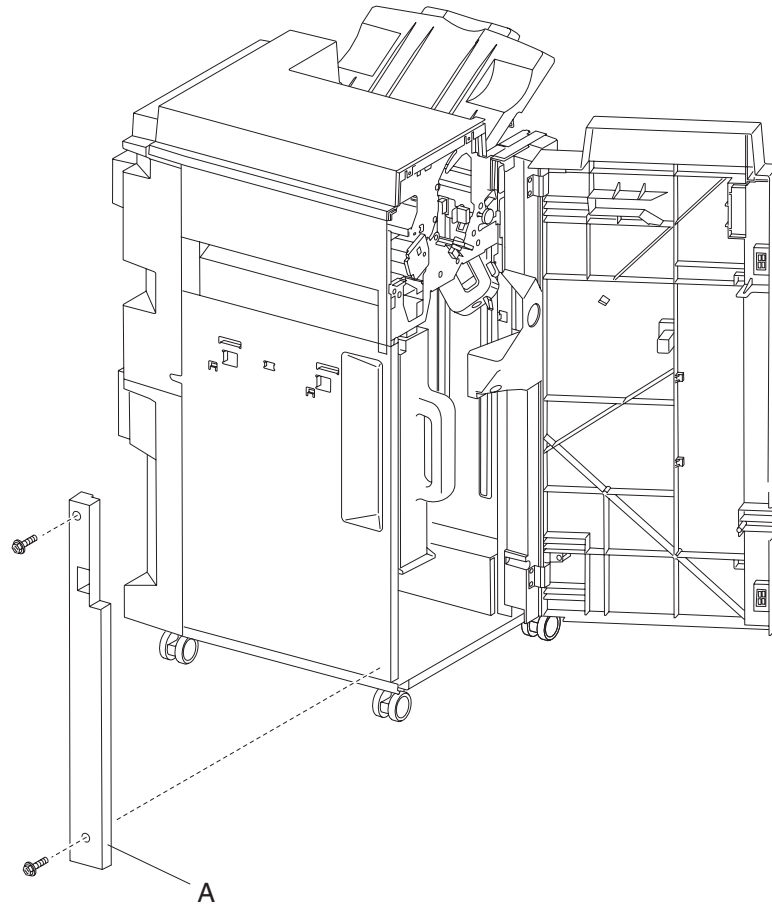

3. Remove the left lower cover (A).

Left upper cover removal

1. Open the finisher front door assembly.
2. Remove the two screws securing the left upper cover (A).

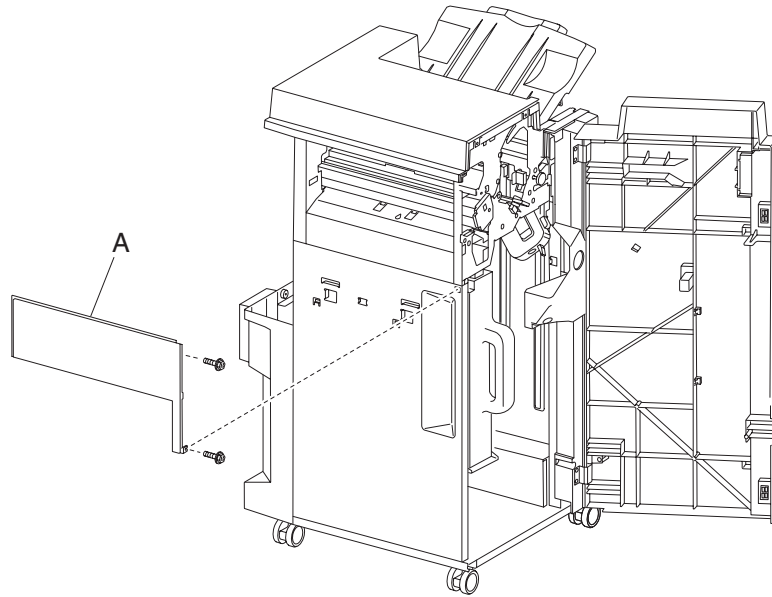

3. Remove the left upper cover (A).

Carriage lift belt left removal

1. Remove the rear upper cover. See **“Rear upper cover removal” on page 4-24.**
 2. Remove the finisher front door assembly. See **“Finisher front door assembly removal” on page 4-27.**
 3. Move the slip clutch gear 24T (A) toward the rear to disengage the stacker bin (B).
 4. Move the stacker bin (B) down to its lowest position after being disengaged.
- Note:** Make sure the stacker bin is at its lowest position before continuing.

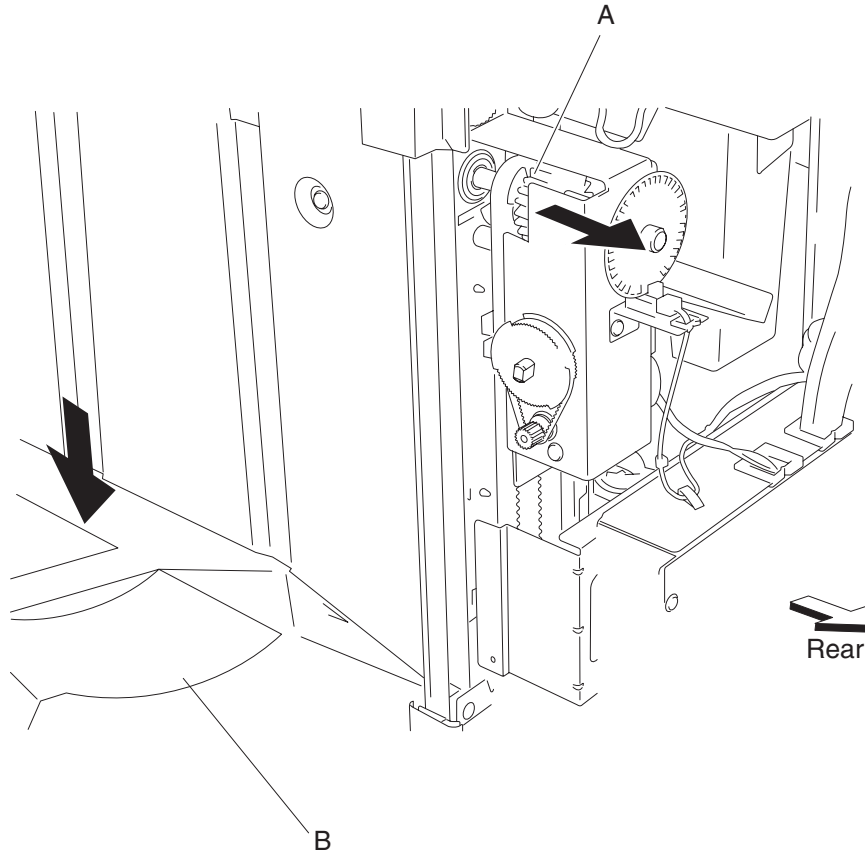

5. Remove the two screws securing the bin bracket (C) to the left carriage bracket (D).
6. Remove the spring (E) from the left carriage lift assembly.
7. Remove the screw securing the upper belt clamp (F) to the left carriage bracket (D).
8. Remove the upper belt clamp (F).
9. Remove the left carriage bracket with the carriage lift belt (G) from the finisher.
10. Release the hook securing the carriage lift belt (G) to the lower belt clamp (H).
11. Remove the carriage lift belt (G).

Replacement notes:

- Make sure the carriage lift belt (G) is inserted into the upper belt clamp (F) as shown.
- Make sure the bin bracket (C) is level to prevent binding.

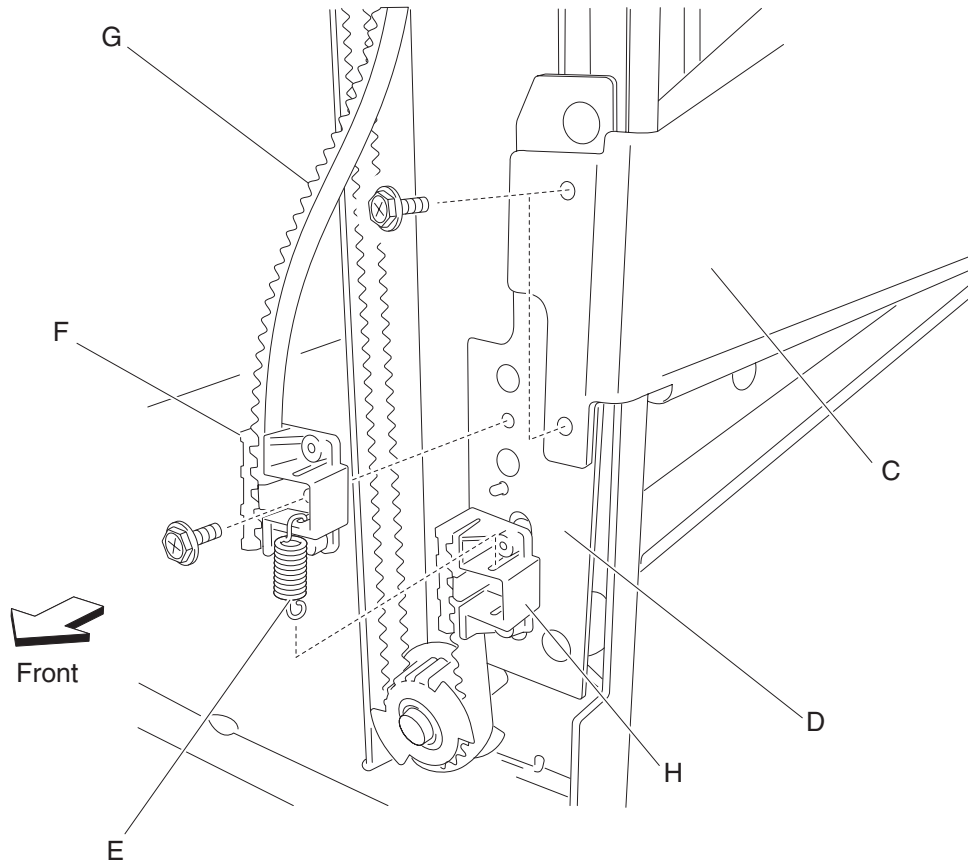

Carriage lift belt right removal

1. Remove the rear upper cover. See **“Rear upper cover removal” on page 4-24.**
2. Remove the finisher front door assembly. See **“Finisher front door assembly removal” on page 4-27.**
3. Move the slip clutch gear 24T (A) toward the rear to disengage the stacker bin (B).
4. Move the stacker bin (B) to its lowest position.

Note: Make sure the stacker bin is at the lowest position before continuing.

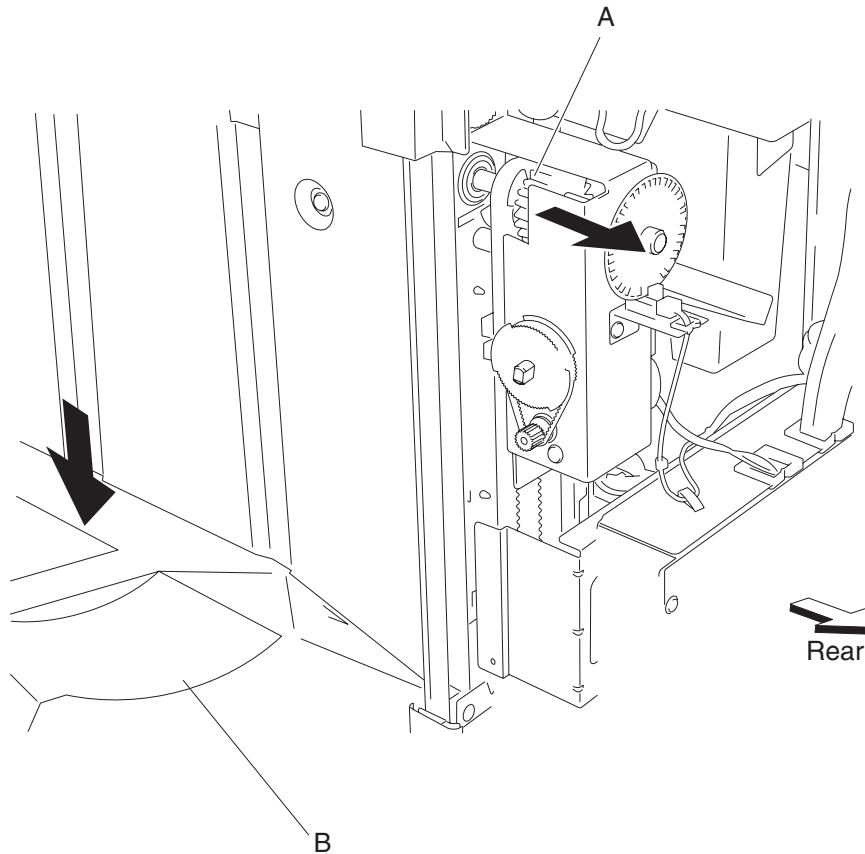

5. Remove the two screws securing the bin bracket (C) to the right carriage bracket (D).
6. Remove the spring (E) from the right carriage bracket (D).
7. Remove the screw securing the upper belt clamp (F) to the right carriage bracket (D).
8. Remove the upper belt clamp (F).
9. Remove the right carriage bracket (D) with the carriage lift belt (G) from the finisher.
10. Release the hook securing the carriage lift belt (G) to the lower belt clamp (H).
11. Remove the carriage lift belt (G).

Replacement notes:

- Make sure the carriage lift belt (G) is inserted into the upper belt clamp (F) as shown.
- Make sure the bin bracket (C) is level to prevent binding.

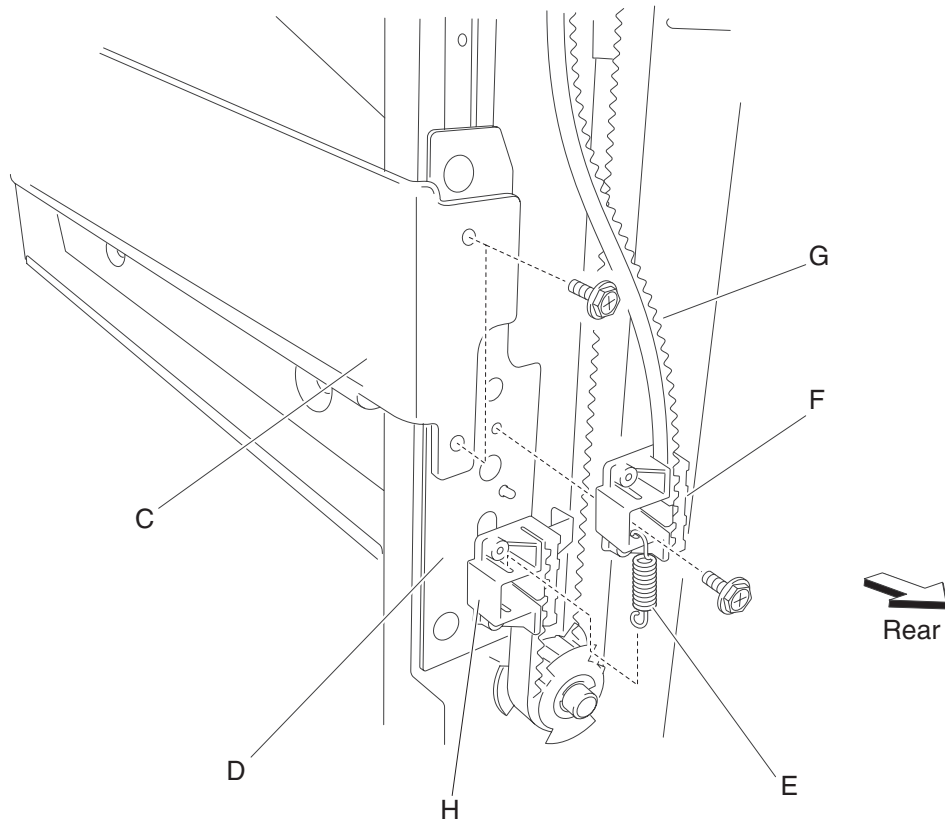

Sensor (stacker bin level 1) removal

1. Remove the finisher front door assembly. See **“Finisher front door assembly removal” on page 4-27.**
2. Remove the rear upper cover. See **“Rear upper cover removal” on page 4-24.**
3. Disconnect the connector from the sensor (stacker bin level 1) (A).

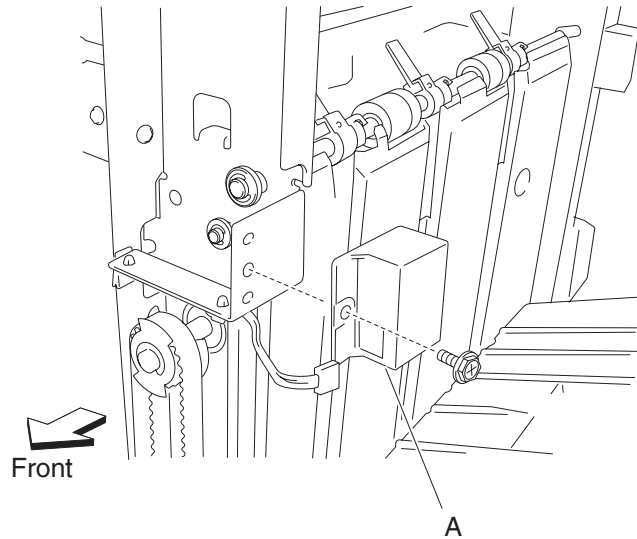

4. Remove the screw securing the sensor (stacker bin level 1) (A) to the finisher.
5. Remove the sensor (stacker bin level 1) (A).

Sensor (stacker bin level 2) removal

1. Remove the finisher front door assembly. See **“Finisher front door assembly removal” on page 4-27.**
2. Remove the rear upper cover. See **“Rear upper cover removal” on page 4-24.**
3. Disconnect the connector from the lift tray height sensor (stacker bin level 2) (A).

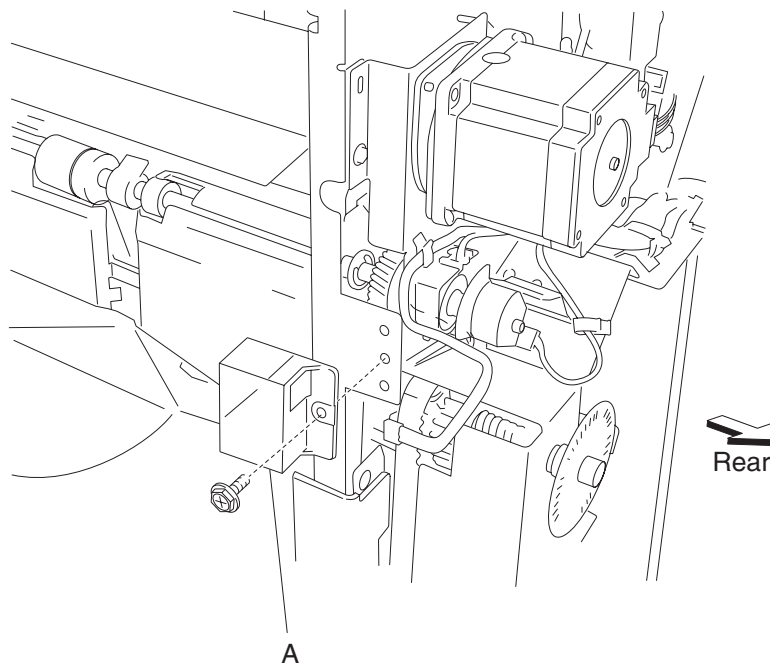

4. Remove the screw securing the sensor (stacker bin level 2) (A).
5. Remove the sensor (stacker bin level 2) (A).

Sensor (stacker bin level encoder) removal

1. Remove the rear upper cover. See **“Rear upper cover removal”** on page 4-24.
2. Disconnect the connector from the sensor (stacker bin level encoder) (A).
3. Release the harness from the clamp.
4. Remove the screw securing the bracket (B) from the stacker bin lift motor assembly (C).

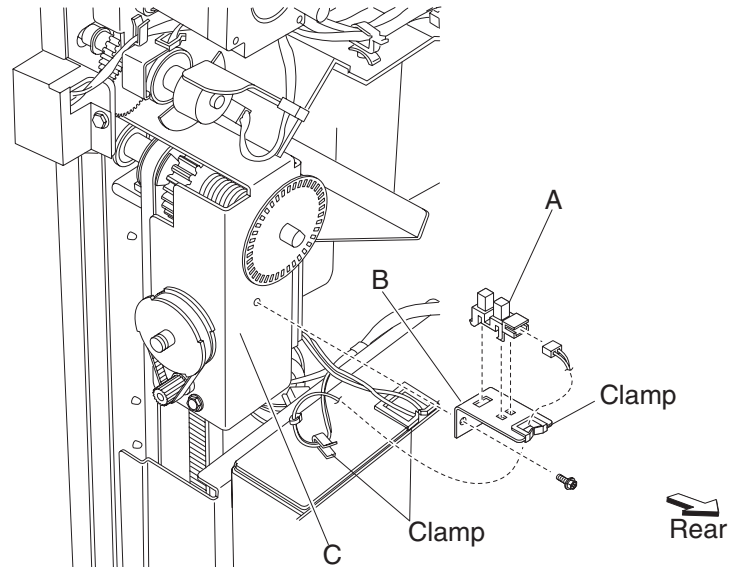

5. Release the hooks securing the sensor to the bracket (B).
6. Remove the sensor (stacker bin level encoder) (A).

Sensor (stacker bin upper limit) or sensor (stacker bin no media) removal

1. Remove the rear upper cover. See **“Rear upper cover removal”** on page 4-24.
2. Remove the stacker media bin assembly. See **“Stacker media bin assembly removal”** on page 4-22.
3. Remove the stacker bin lift motor assembly. See **“Stacker bin lift motor assembly removal”** on page 4-38.
4. Remove the four screws securing the metal cover (A) to the finisher.
5. Remove the metal cover (A).

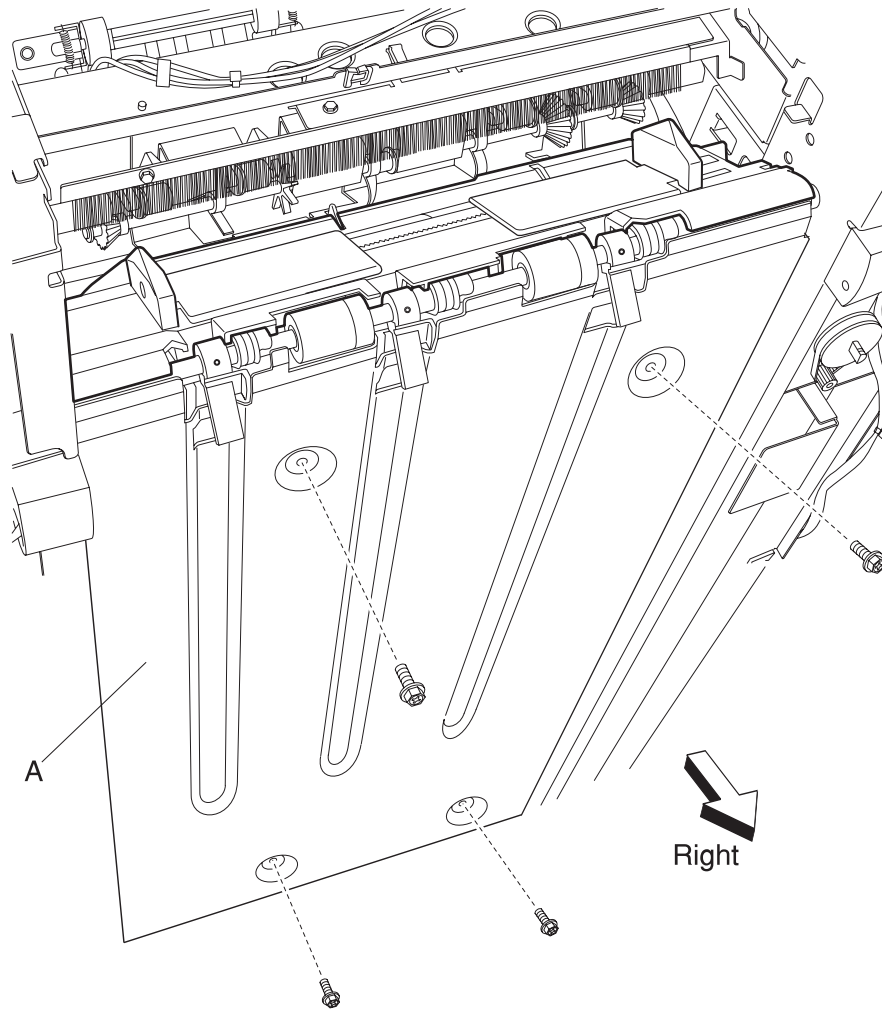

6. Disconnect the connector from the sensor (stacker bin upper limit) (B) or the sensor (stacker bin no media) (C).
7. Release the hooks of the selected sensor.
8. Remove the sensor.

Replacement note: Make sure that the yellow connector is plugged into the sensor (stacker bin no media) (C).

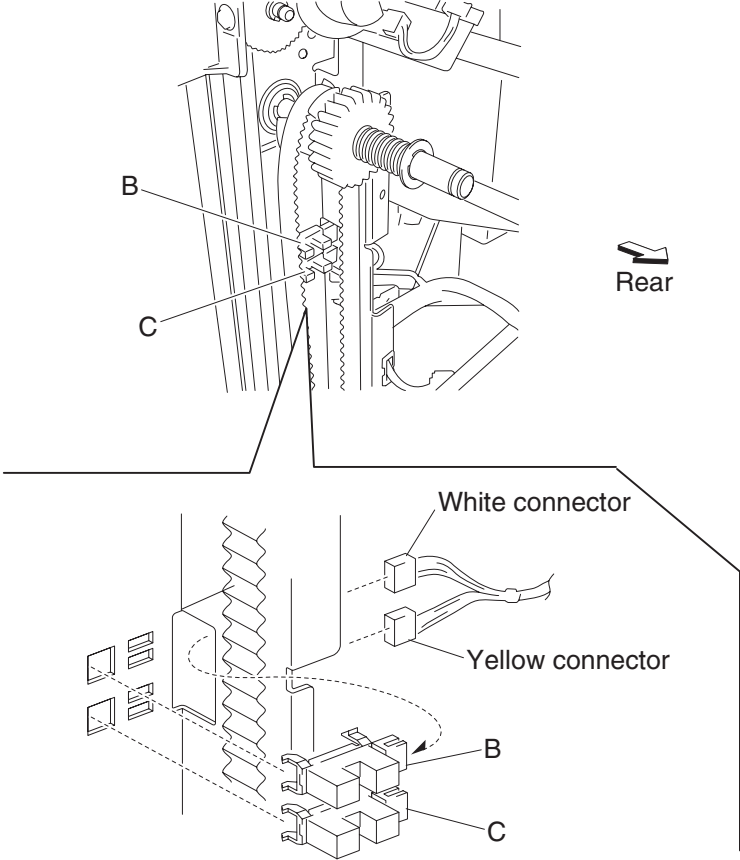

Stacker bin lift motor assembly removal

1. Remove the rear upper cover. See **“Rear upper cover removal”** on page 4-24.
2. Remove the rear lower cover. See **“Rear lower cover removal”** on page 4-23.
3. Loosen the four screws securing the plate (A).
4. Move the plate (A) toward the right as shown.

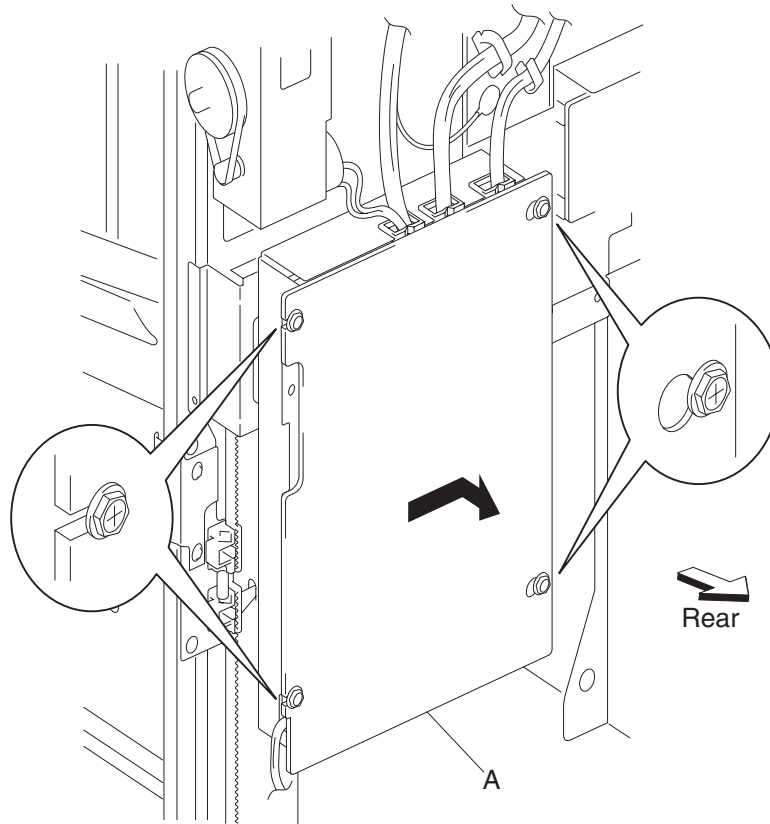

5. Remove the plate (A).

6. Move the slip clutch gear 24T (B) toward the rear to disengage the stacker bin (C).
7. Move the stacker bin (C) to the lowest position.
Note: Make sure the stacker bin (C) is at the lowest position before continuing.
8. Disconnect the connector from the sensor (stacker bin level encoder) (D).
9. Release the harness from the clamps.

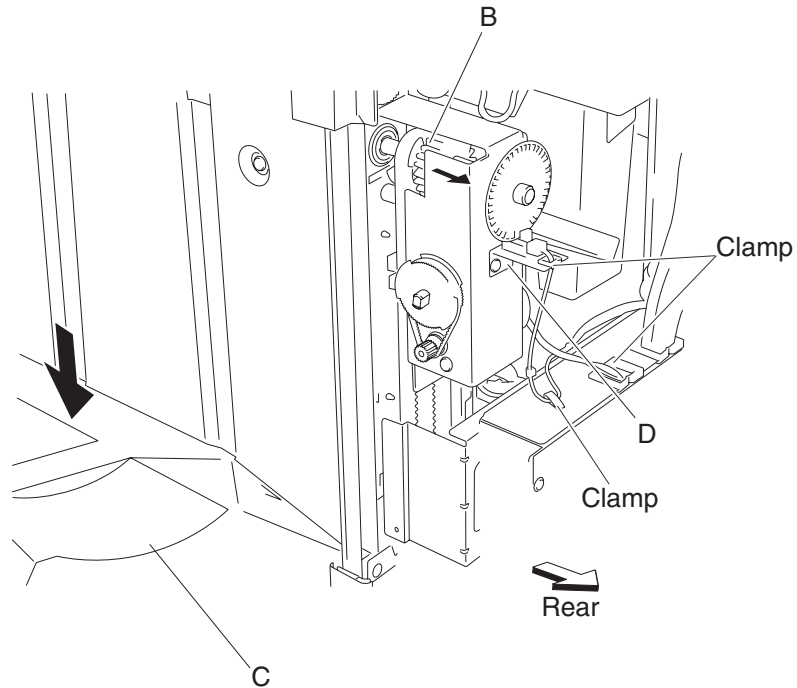

10. Disconnect the connector (P8305) from the finisher controller card assembly (E).

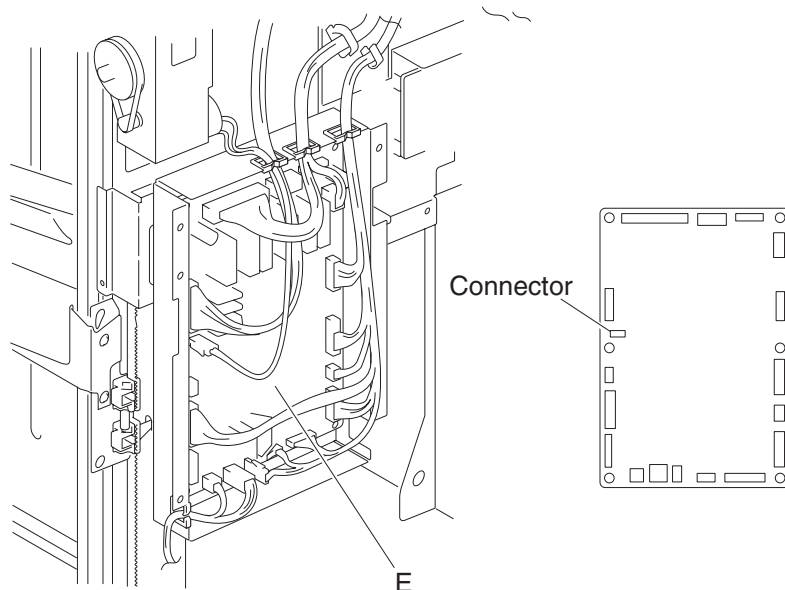

11. Remove the screw securing the bracket (F) to the stacker bin lift motor assembly (G).
12. Remove the bracket (F).

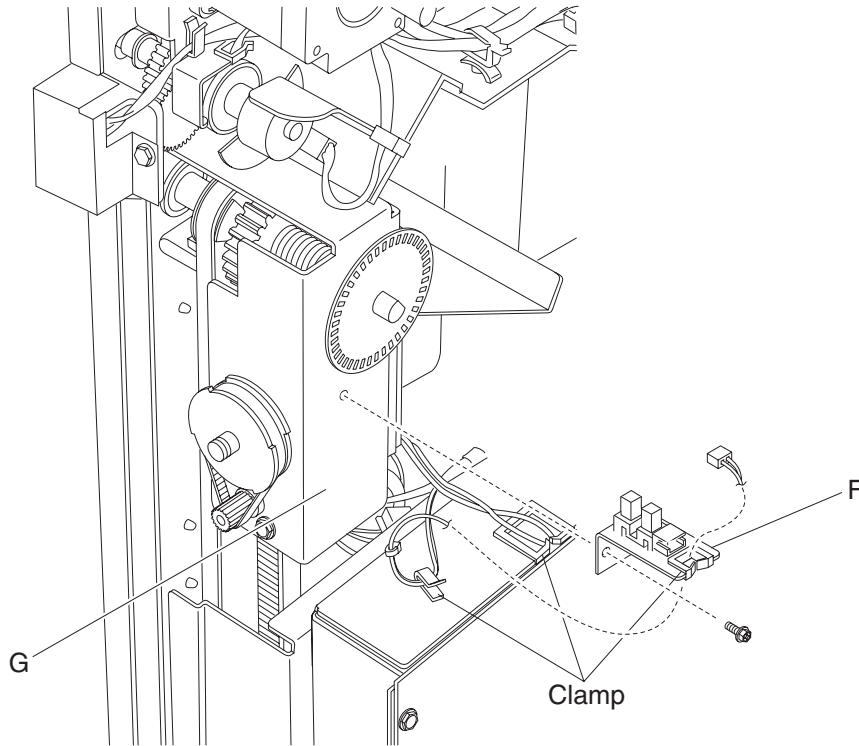

13. Release the hook securing the encoder (H) to the stacker bin lift motor assembly (G).
14. Remove the encoder.
15. Remove the three screws securing the stacker bin lift motor assembly (G) to the finisher.

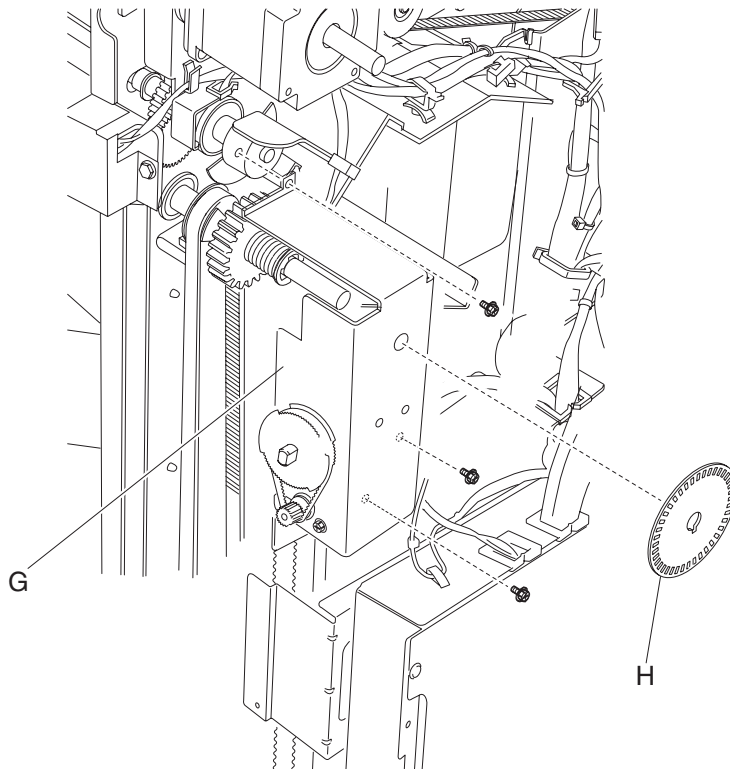

16. Remove the stacker bin lift motor assembly (G).

Punch carriage assembly removal

1. Open the finisher front door assembly.
2. Remove the rear upper cover. See **“Rear upper cover removal”** on page 4-24.
3. Remove the connector from the sensor (punch carriage shift HP) (A).
4. Remove the top cover. See **“Top cover removal”** on page 4-19.
5. Release the harness from the punch carriage assembly (B).
6. Remove the connector from the punch carriage shift motor assembly (C).
7. Release the two punch unit assembly harnesses from the three clamps on the rear of the finisher.
8. Disconnect the two punch unit assembly harnesses from the main harness.
9. Remove the screw securing the grounding wire (D) to the punch unit carriage assembly (B).
10. Remove the two screws on the rear securing the punch carriage assembly (B) to the finisher.

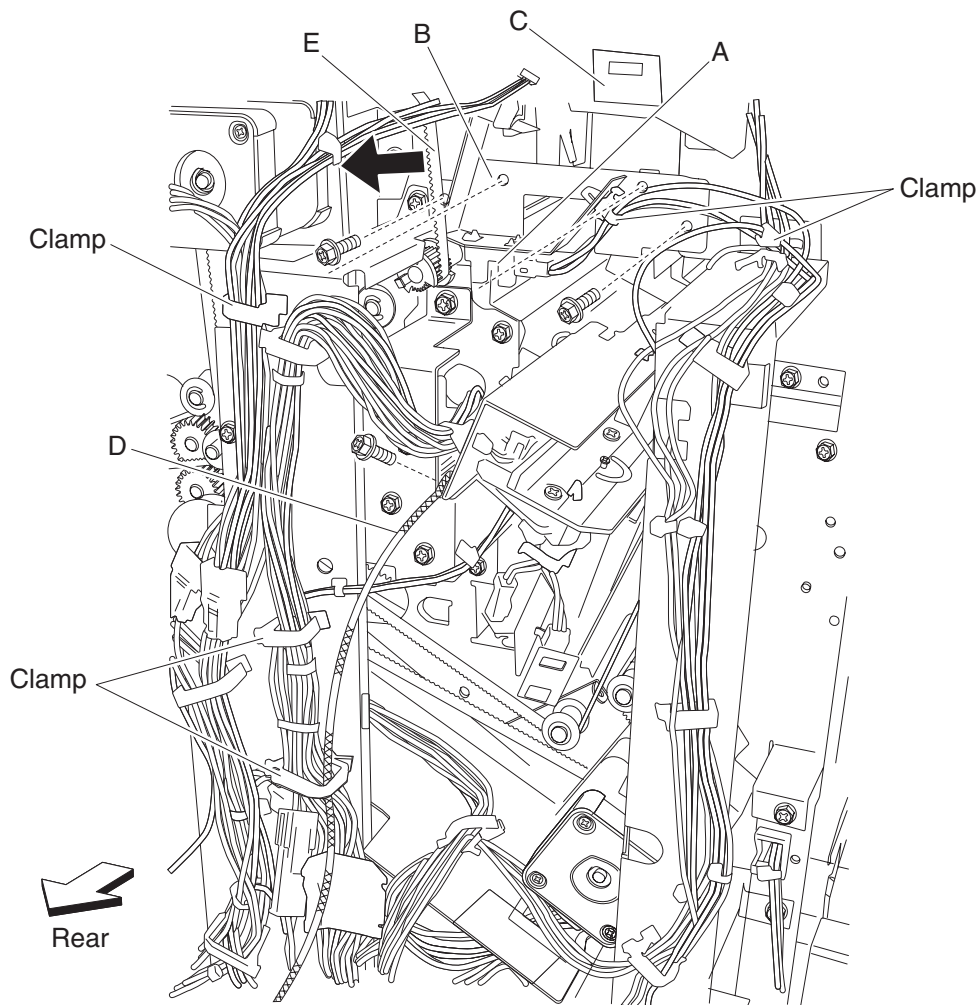

11. Remove the two screws on the front securing the punch carriage assembly (B) to the finisher.

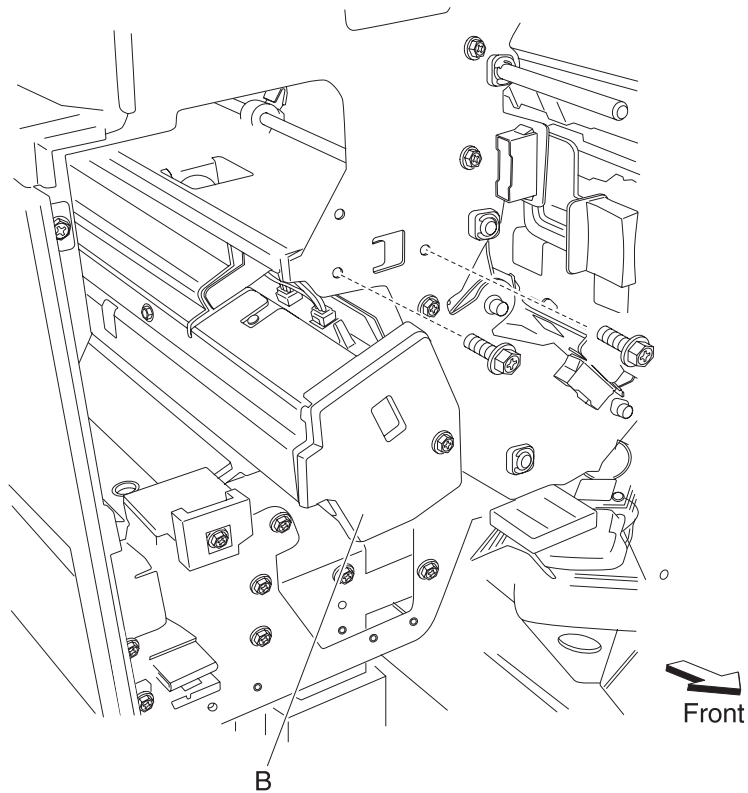

12. While moving the belt (buffer/transport) (E) to the left as shown, pull the punch carriage assembly (B) gently out of the rear of the finisher.

Warning: Do not force the punch carriage assembly (B) out of the finisher. Be sure to hold the unit firmly to avoid dropping it.

Replacement notes:

- Do not force the punch unit into the finisher.
- Be sure to hold the punch carriage assembly firmly to avoid dropping it.
- Make sure all harnesses are properly clamped.
- Make sure the punch carriage assembly is able to shift back and forth completely without binding the harnesses.
- Make sure the harnesses do not come into contact with any rotating mechanisms.

Punch carriage shift motor assembly removal

1. Open the finisher front door assembly.
2. Remove the rear upper cover. See **“Rear upper cover removal” on page 4-24.**
3. Remove the punch carriage assembly. See **“Punch carriage assembly removal” on page 4-41.**
4. Remove the two screws securing the cover (A) to the punch carriage assembly (B).
5. Remove the cover (A).
6. Remove the two screws securing the punch carriage shift motor assembly (C) to the punch unit assembly (B).

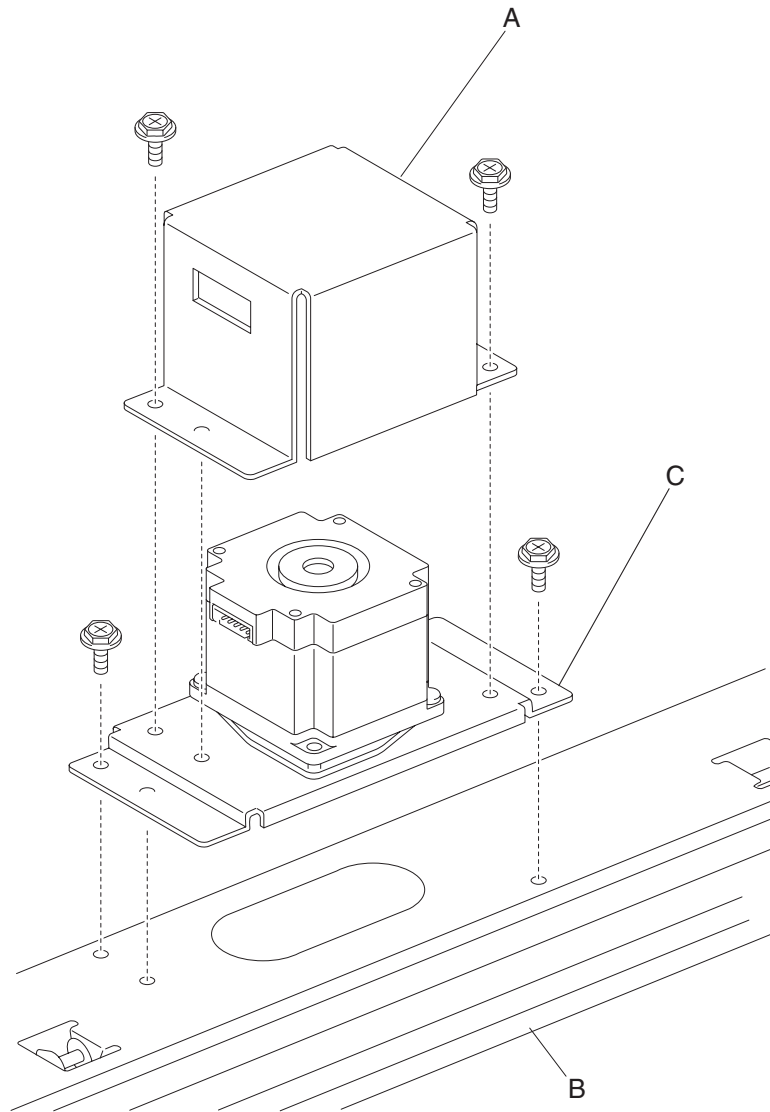

7. Remove the punch carriage shift motor assembly (C).

Sensor (punch unit side registration pair) with bracket removal

1. Open the finisher front door assembly.
2. Remove the rear upper cover. See **“Rear upper cover removal” on page 4-24.**
3. Remove the punch carriage assembly. See **“Punch carriage assembly removal” on page 4-41.**
4. Remove the screw securing the cover (A) to the punch unit assembly (B).
5. Remove the cover.
6. Remove the two screws securing the paper guide (C) to the punch unit assembly (B).
Note: Do not remove the harness attached to the paper guide (C).

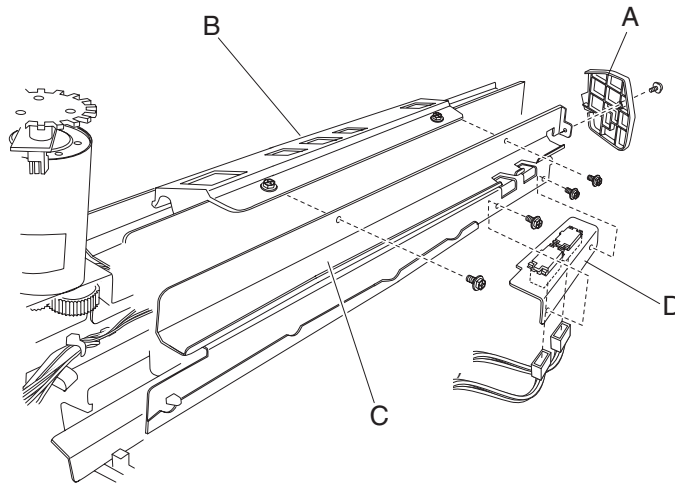

7. Turn the paper guide (C) upside down.
8. Remove the two screws securing the bracket (D) to the paper guide (C).
9. Remove the bracket (D).
10. Remove the two connectors from the sensor (punch unit side registration pair) (E).
11. Release the hooks securing the sensors (punch unit side registration pair) (E) to the bracket (D).

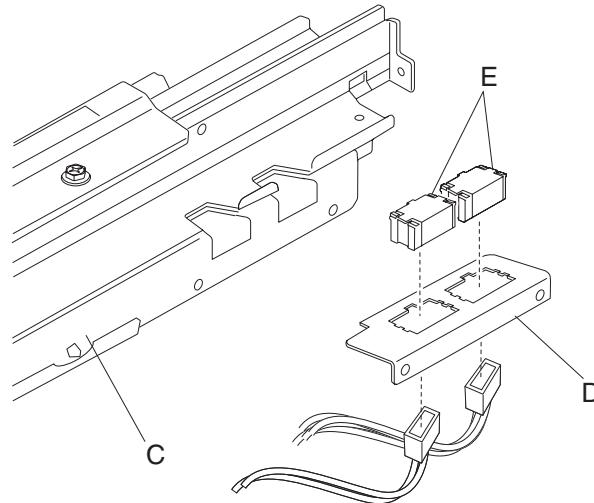

12. Remove the sensor (punch unit side registration pair) (E).
Note: The two sensors are identical.

Punch unit assembly removal

1. Open the finisher front door assembly.
2. Remove the rear upper cover. See **“Rear upper cover removal” on page 4-24.**
3. Remove the punch carriage assembly. See **“Punch carriage assembly removal” on page 4-41.**
4. Remove the screw securing the cover (A) to the punch unit assembly (B).
5. Remove the cover (A).
6. Remove the two screws securing the bracket (C) to the punch carriage assembly (D).
7. Remove the bracket (C).
8. Remove the three screws securing the punch carriage assembly (D) to the punch unit assembly (B).

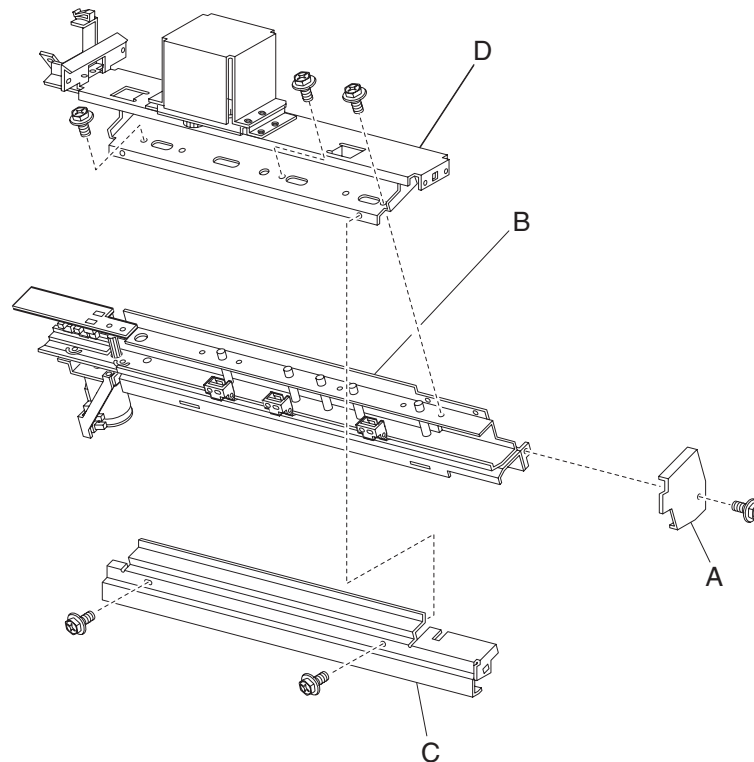

9. Remove the punch unit assembly (B)

Punch media stop assembly removal

1. Open the finisher front door assembly.
2. Remove the rear upper cover. See **“Rear upper cover removal” on page 4-24.**
3. Remove the punch carriage assembly. See **“Punch carriage assembly removal” on page 4-41.**
4. Remove the punch unit assembly. See **“Punch unit assembly removal” on page 4-45.**
5. Remove the three screws securing the three punch media stop assemblies (D) to the punch unit assembly (B).

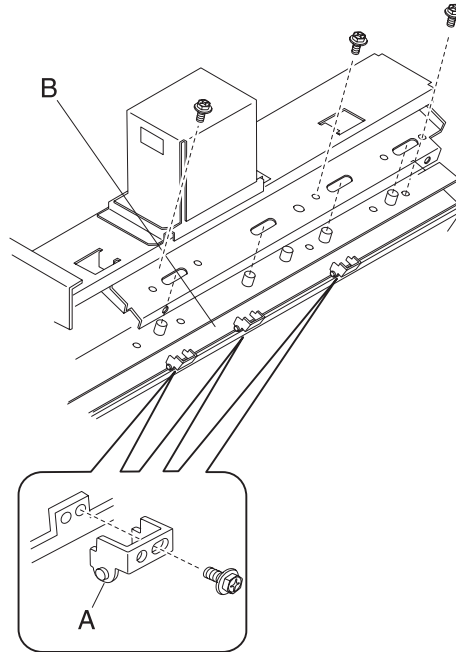

6. Remove the three punch media stop assemblies (D).

Punch unit motor assembly removal

1. Open the finisher front door assembly.
2. Remove the rear upper cover. See **“Rear upper cover removal”** on page 4-24.
3. Remove the punch carriage assembly. See **“Punch carriage assembly removal”** on page 4-41.
4. Disconnect the connector from the punch unit motor assembly (A).
5. Disconnect the connector from the sensor (punch unit motor encoder) (B).
6. Remove the harness from the clamp.
7. Remove the two screws securing the punch unit motor assembly (A) to the punch unit assembly (C).

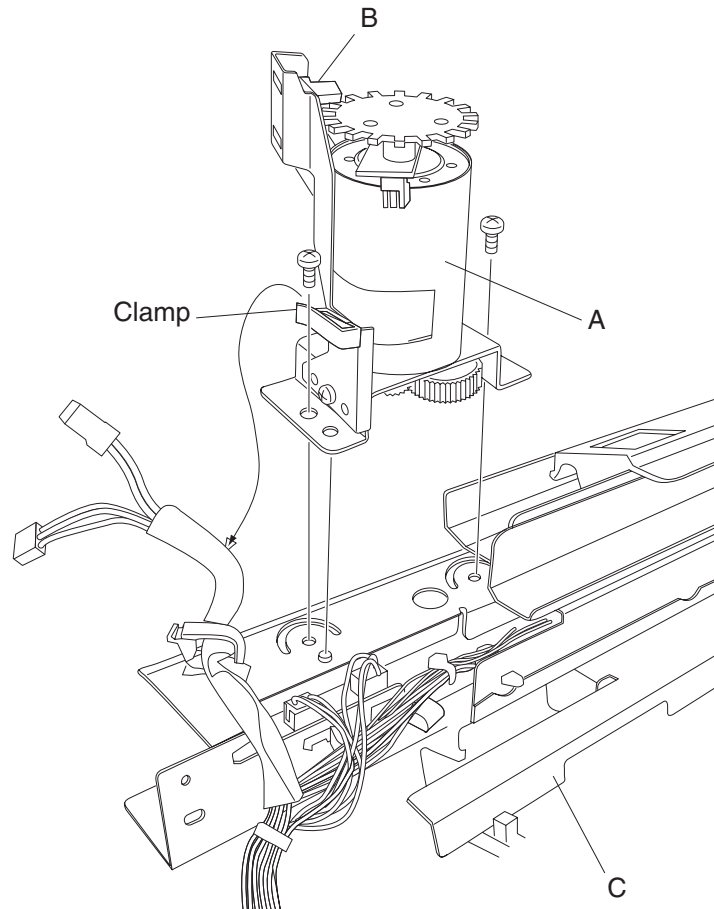

8. Remove the punch unit motor assembly.

Sensor (punch unit motor encoder) removal

1. Open the finisher front door assembly.
2. Remove the rear upper cover. See **“Rear upper cover removal” on page 4-24.**
3. Remove the punch carriage assembly. See **“Punch carriage assembly removal” on page 4-41.**
4. Disconnect the connector from the punch unit motor assembly (A).
5. Disconnect the connector from the sensor (punch unit motor encoder) (B).
6. Remove the harness from the clamp.
7. Remove the two screws securing the bracket (C) to the punch unit assembly (D).

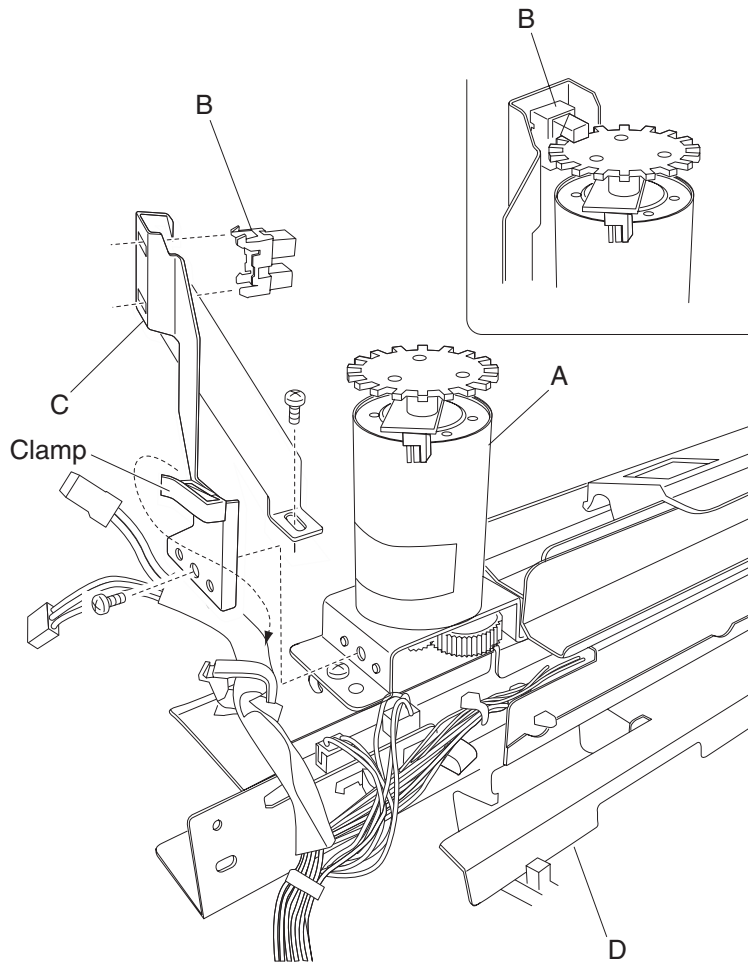

8. Release the hooks securing the sensor (punch unit motor encoder) (B) to the bracket (C).
9. Remove the sensor (punch unit motor encoder) (B).

Sensor (punch hole select), sensor (punch cam front), and sensor (punch unit HP) removal

1. Open the finisher front door assembly.
2. Remove the rear upper cover. See **“Rear upper cover removal” on page 4-24.**
3. Remove the punch carriage assembly. See **“Punch carriage assembly removal” on page 4-41.**
4. Remove the screw securing the bracket (A) to the punch unit assembly (B).

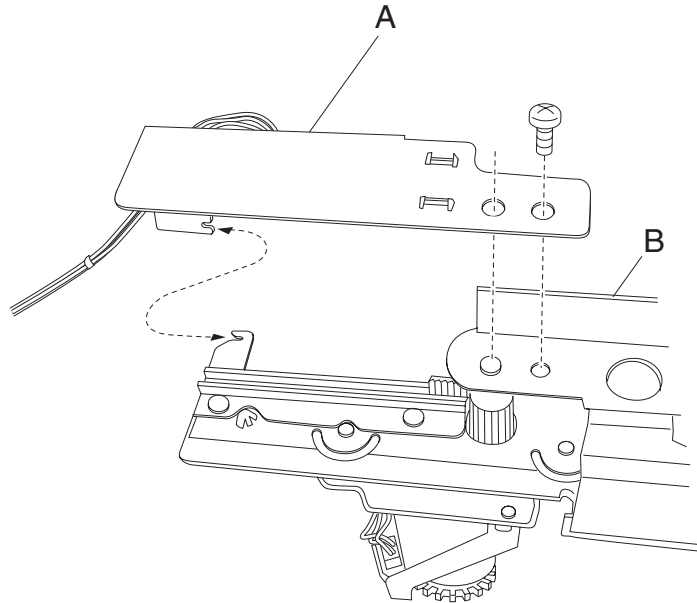

5. Disconnect the connector from the sensor (punch hole select) (C), the sensor (punch cam front) (D), or the sensor (punch unit HP) (E).
6. Release the hooks securing the sensor(s) to the bracket.
7. Remove the sensor(s).

Replacement note: Make sure the color coded connectors are connected to the proper sensors, as shown.

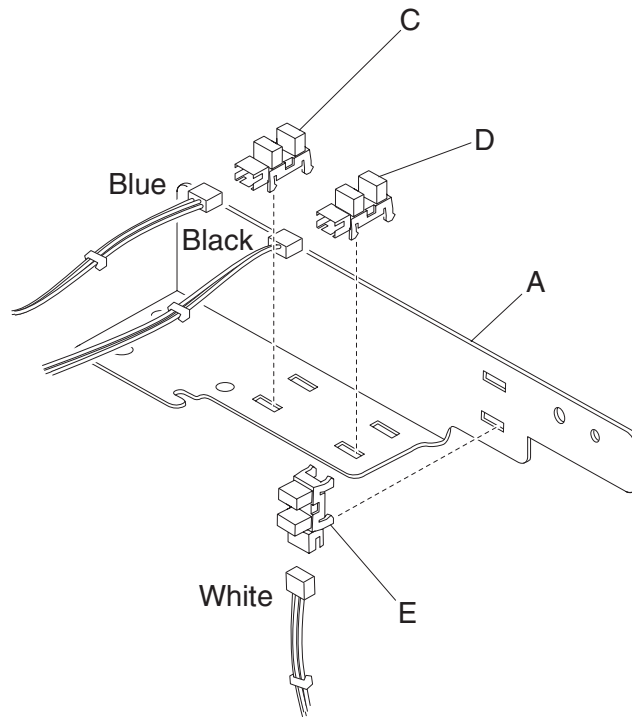

Sensor (punch carriage shift HP) removal

1. Open the finisher front door assembly.
2. Remove the rear upper cover. See **“Rear upper cover removal” on page 4-24.**
3. Remove the punch carriage assembly. See **“Punch carriage assembly removal” on page 4-41.**
4. Remove the one screw securing the bracket (A) to the punch carriage unit (B).
5. Release the hooks securing the sensor (punch carriage shift HP) (C) to the bracket (A).

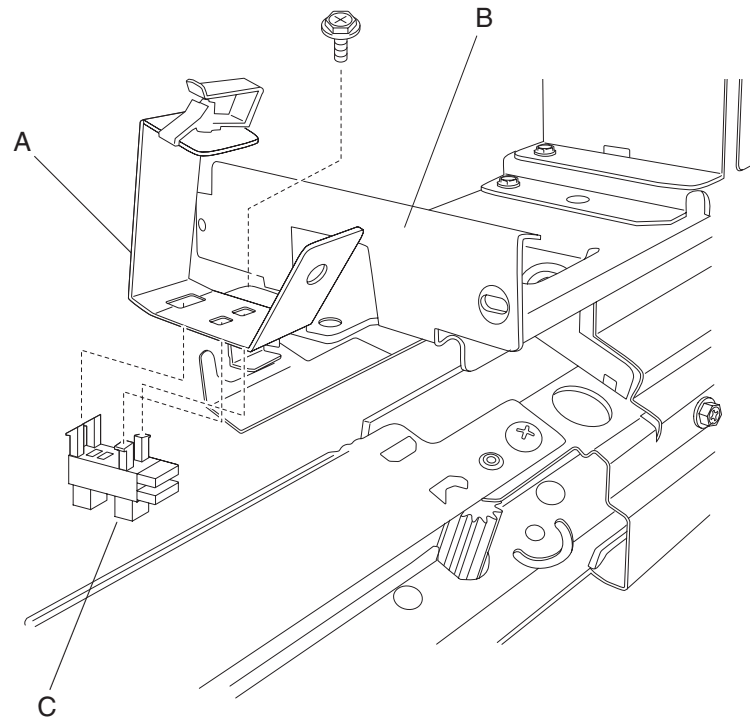

6. Remove the sensor (punch carriage shift HP) (C).

Sensor (punch waste box set) removal

1. Open the finisher front door assembly.
2. Pull the punch waste box.
3. Disconnect the connector from the sensor (punch waste box set) (A).
4. Release the hooks securing the sensor (punch waste box set) (A) to the finisher.

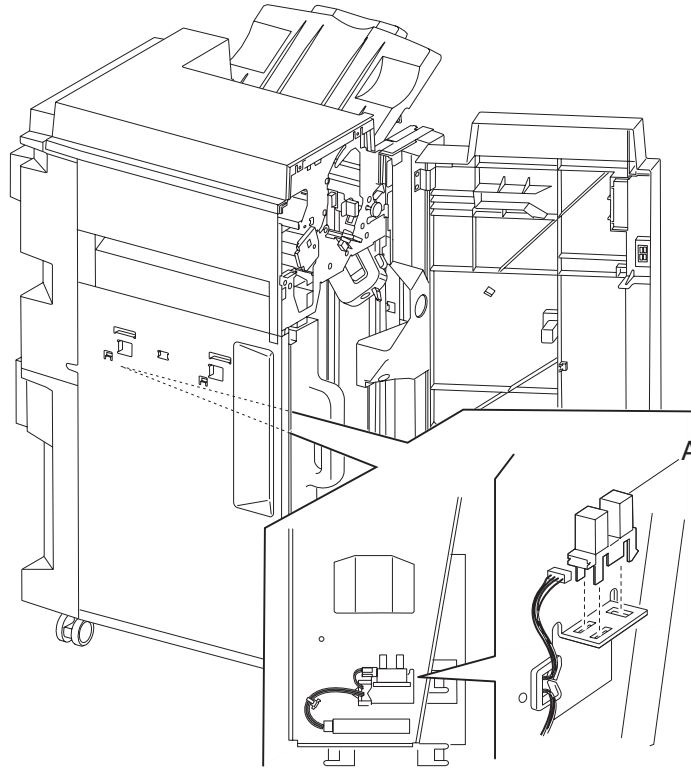

5. Remove the sensor (punch waste box set) (A).

Sensor (punch waste box full) removal

1. Open the finisher front door assembly.
2. Remove the punch waste box (A) from the finisher.
3. Disconnect the connector from the sensor (punch waste box full) (B).
4. Release the hooks securing the sensor (punch waste box full) (B) to the finisher.

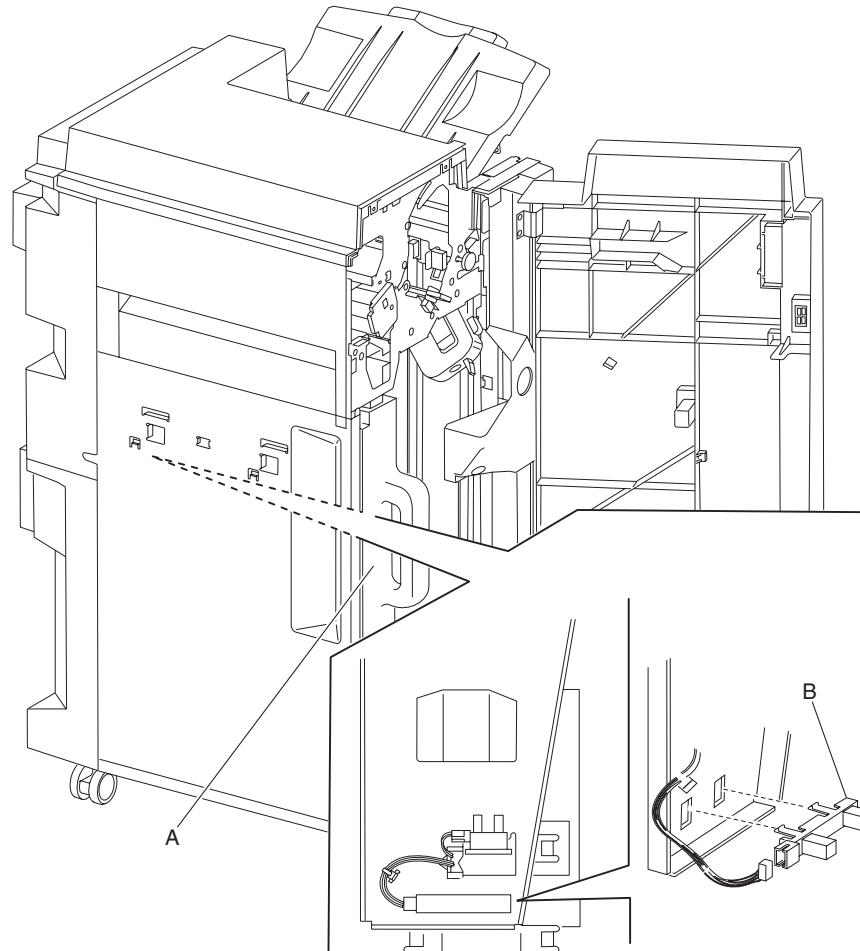

5. Remove the sensor (punch waste box full) (B).

Stapler unit frame removal

1. Remove the finisher front door assembly. See **“Finisher front door assembly removal”** on page 4-27.
2. Remove the staple cartridge.
3. Remove the rear upper cover. See **“Rear upper cover removal”** on page 4-24.
4. Remove the rear lower cover. See **“Rear lower cover removal”** on page 4-23.
5. Loosen the four screws securing the plate (A) to the finisher.
6. Move the plate (A) toward the right and out in the direction shown.

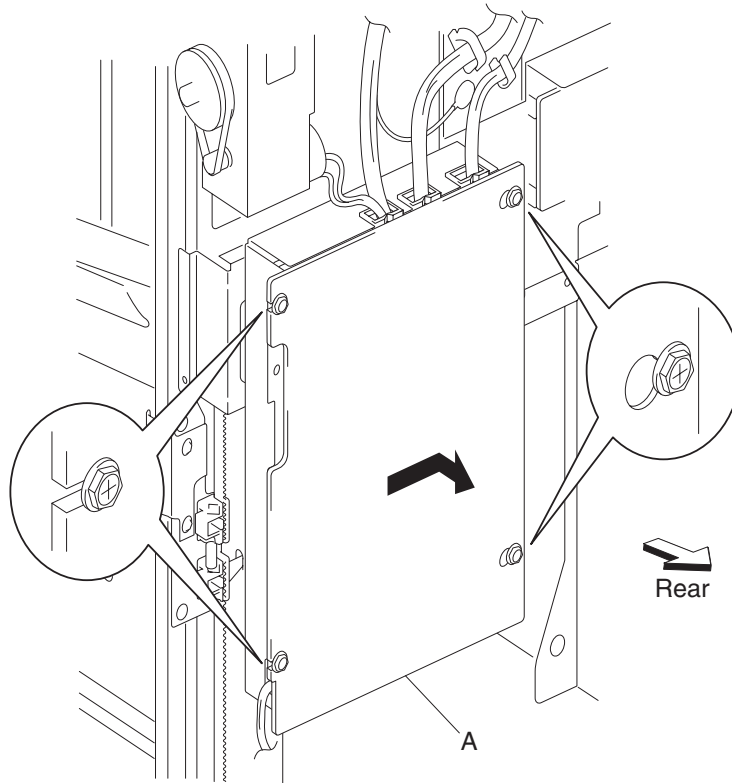

7. Remove the plate.

8. Disconnect the connector P8308 from the finisher controller card assembly (B).
9. Remove the screw securing the ground wire (C) to the finisher.
10. Release the harness from the clamp.

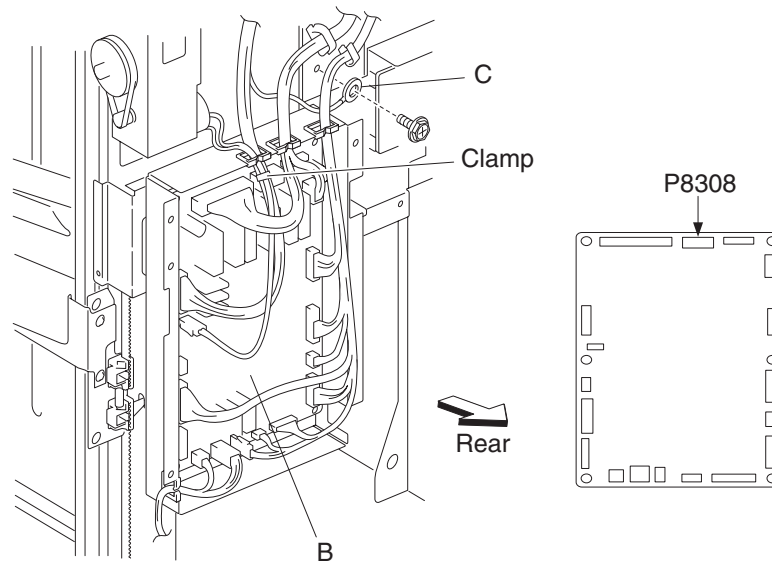

11. Remove the media stacker bin lift motor assembly. See **“Stacker media bin assembly removal”** on page 4-22.
12. Disconnect the two connectors from the sensor (stacker bin upper limit) (D) and the sensor (stacker bin no media) (E).
13. Remove the four screws securing the stapler unit frame (F) to the finisher.
14. Move the stapler unit frame upward and outward in the direction of the arrow, as shown.

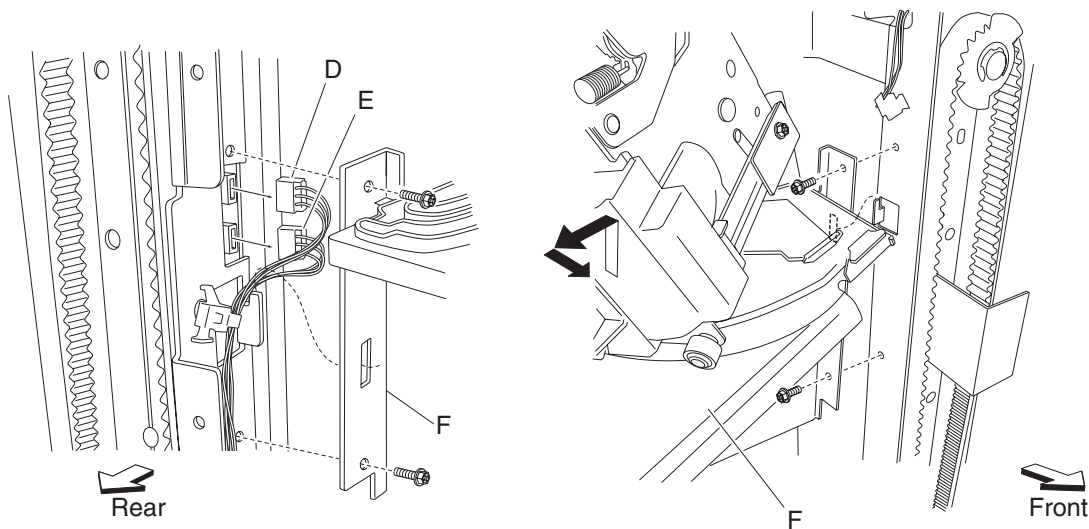

15. Remove the stapler unit frame.

Warning: Do not force the stapler unit frame out of the finisher.

Warning: Be sure to hold the stapler unit frame firmly to avoid dropping it.

Replacement notes:

- Do not force the stapler unit frame into the finisher.
- Be sure to hold the stapler unit frame firmly to avoid dropping it.
- Make sure no harnesses are pinched when replacing the stapler unit frame.
- Be sure to replace the grounding wire.

Stapler unit assembly removal

1. Remove the finisher front door assembly. See **“Finisher front door assembly removal”** on page 4-27.
2. Remove the staple cartridge.
3. Remove the rear upper cover. See **“Rear upper cover removal”** on page 4-24.
4. Remove the rear lower cover. See **“Rear lower cover removal”** on page 4-23.
5. Remove the stapler unit frame. See **“Stapler unit frame removal”** on page 4-54.
6. Remove the five screws securing the stapler unit frame (A) to the plate (B).

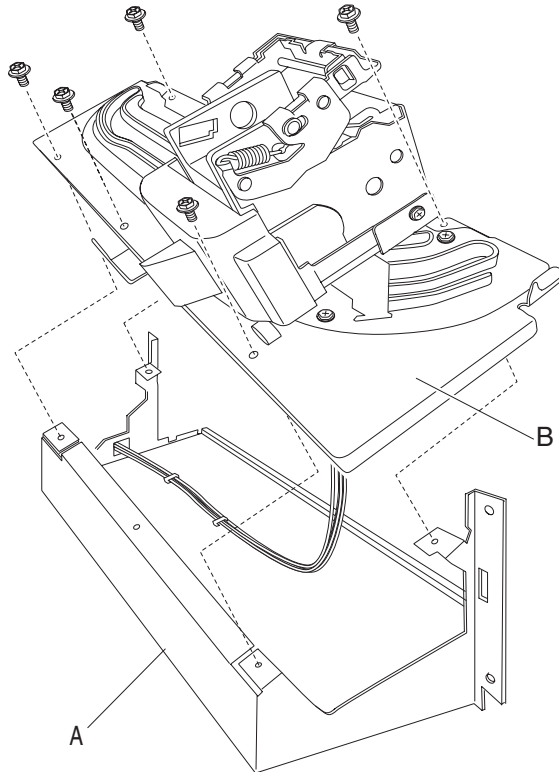

7. Remove the stapler unit frame (A).
8. Release the harness from the three clamps on the stapler unit frame (A).
9. Remove the two screws securing the stapler carriage motor assembly (C) to the stapler carriage assembly (D).
10. Remove the stapler carriage motor assembly (C).

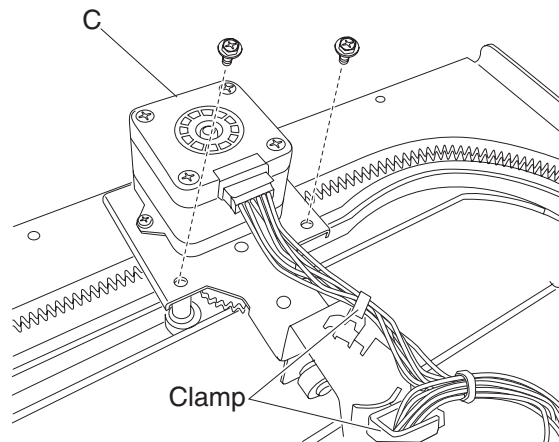

11. Remove the screw securing the stapler cover (E) to the stapler unit assembly (F).
12. Remove the stapler cover (E).
13. Disconnect the two connectors from the stapler unit assembly (F).
14. Disconnect the connector from the sensor (stapler carriage HP) (G).
15. Remove the two screws securing the bracket (H) to the stapler carriage assembly (D).
16. Remove the bracket (H).
17. Remove the two screws securing the bracket (H) to the stapler unit assembly (F).

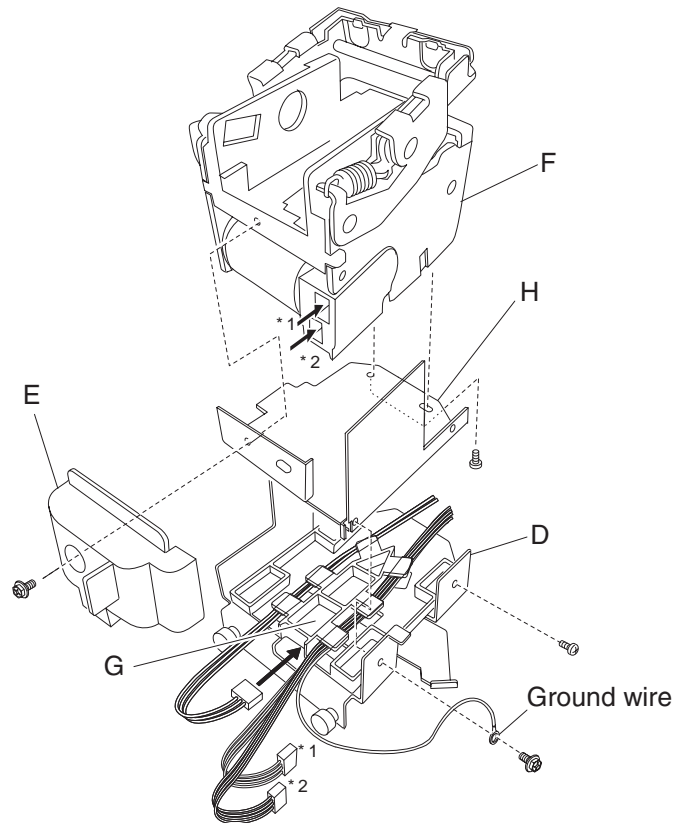

18. Remove the stapler unit assembly (F).

Replacement notes:

- When replacing the stapler unit assembly (F), make sure the ground wire is reconnected.
- Make sure the stapler carriage assembly (D) and the stapler carriage motor assembly (C) move freely without binding.

Sensor (stapler carriage HP) removal

1. Remove the finisher front door assembly. See **“Finisher front door assembly removal” on page 4-27.**
2. Remove the staple cartridge.
3. Remove the rear upper cover. See **“Rear upper cover removal” on page 4-24.**
4. Remove the rear lower cover. See **“Rear lower cover removal” on page 4-23.**
5. Remove the stapler unit frame. See **“Stapler unit frame removal” on page 4-54.**
6. Remove the stapler unit assembly. See **“Stapler unit assembly removal” on page 4-56.**
7. Release the hooks securing the sensor (stapler carriage HP) (A) to the stapler carriage assembly (B).

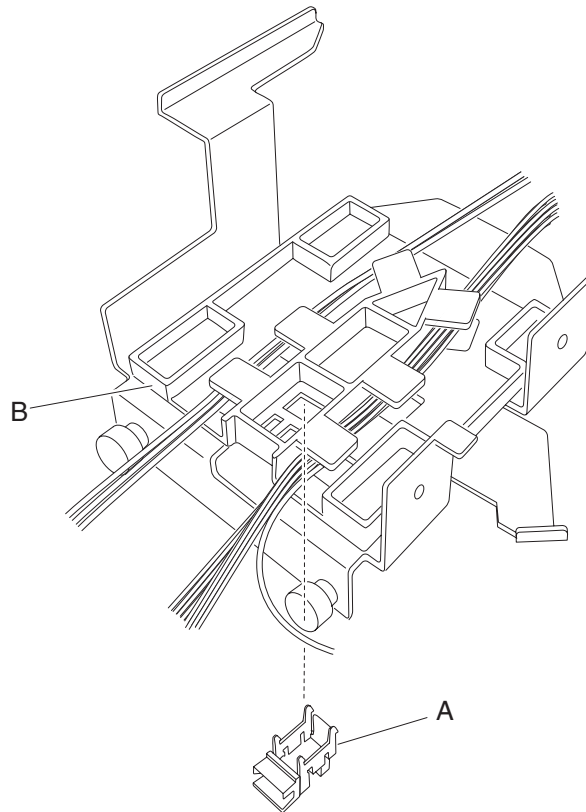

8. Remove the sensor (stapler carriage HP) (A).

Media eject unit assembly removal

1. Remove the finisher front door assembly. See **“Finisher front door assembly removal”** on page 4-27.
2. Remove the rear upper cover. See **“Rear upper cover removal”** on page 4-24.
3. Remove the upper media bin assembly. See **“Upper media bin assembly removal”** on page 4-20.
4. Remove the upper media bin vertical cover. See **“Right eject cover removal”** on page 4-21.
5. Remove the two media eject unit springs (A) by pushing them downward.
6. Disconnect the connector from the eject unit solenoid (B).
7. Release the harness from the two clamps.

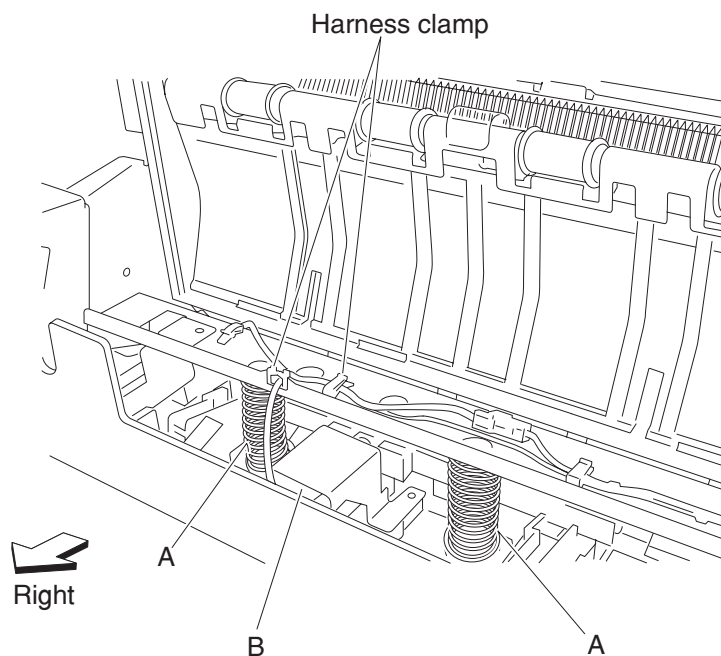

8. Remove the screw securing the eject clamp lever assembly (C) from the shaft (D) on the rear of the finisher.
9. Remove the eject clamp lever assembly (C).
10. Remove the e-clip securing the shaft (D) to the rear of the finisher.
11. Remove the 8 mm bushing (E) on the rear side.

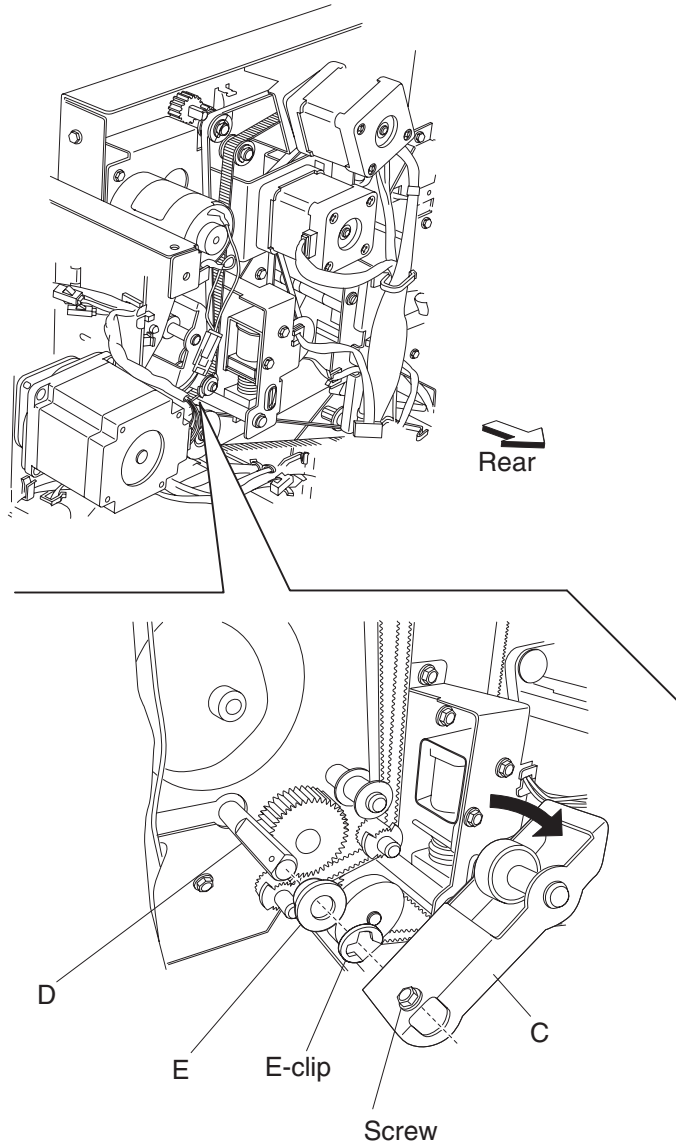

12. Remove the e-clip securing the shaft (F) to the front of the finisher.
13. Remove the 8 mm bushing (E) on the front side.

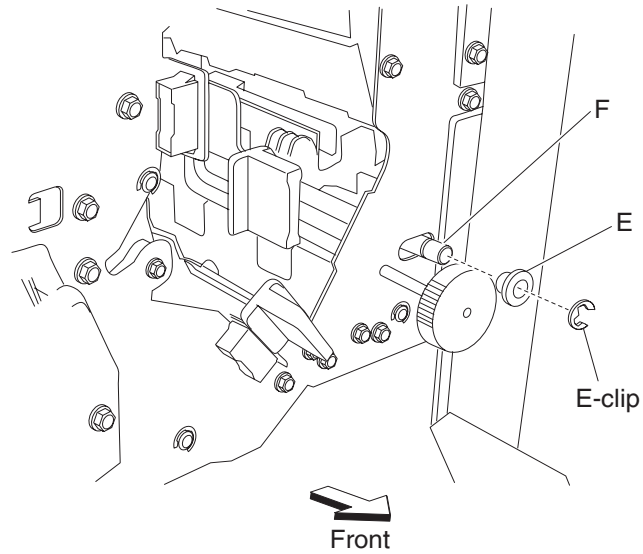

14. Gently move the left side of the media eject unit assembly (G) out of the finisher followed by the right side.
Note: Do not force the media eject unit assembly out of the finisher. Remove the left side before the right side.

Note: Tilting the media eject unit assembly slightly may make the removal easier.

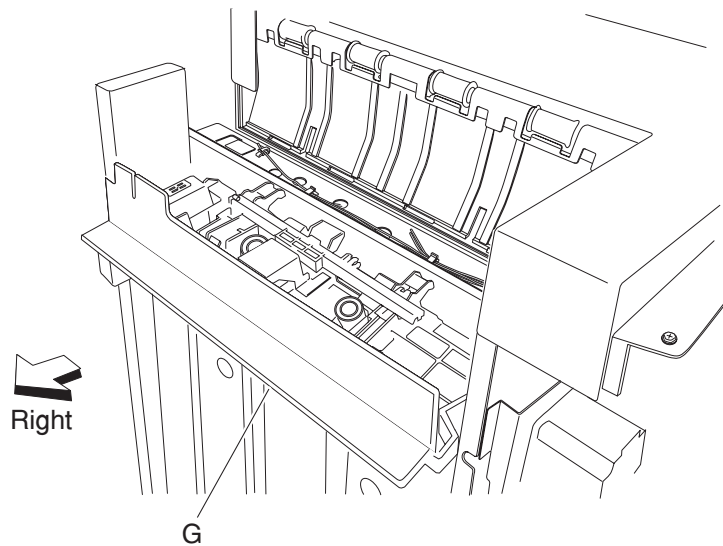

15. Remove the media eject unit assembly.

Replacement notes

- Do not force the media eject unit assembly into the finisher. Insert the right side before the left side.
- Make sure the media eject unit assembly properly actuates the switch (eject cover interlock) (H) without binding.

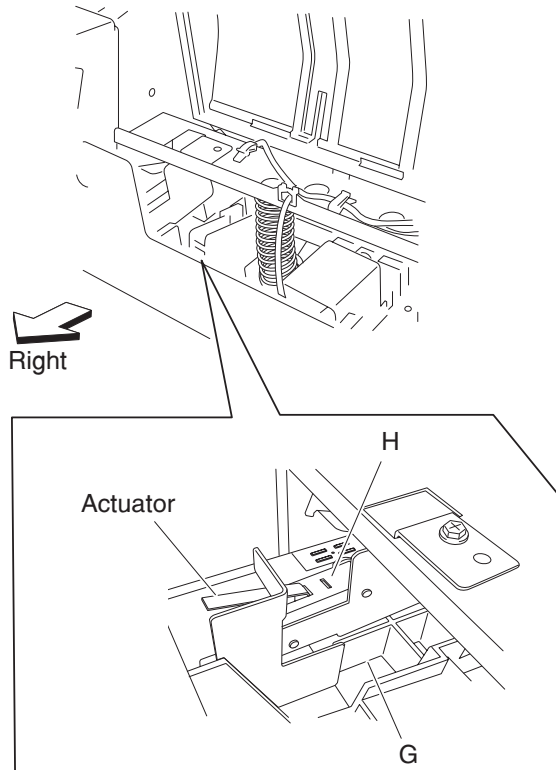

Sub paddle removal

1. Remove the upper media bin assembly. See **“Upper media bin assembly removal”** on page 4-20.
2. Gently remove the two sub paddles (A) from the two shafts (B).

Replacement notes: Make sure the sub paddles are properly installed as shown in the figure. The paddles must not come in contact with the media eject unit assembly (C).

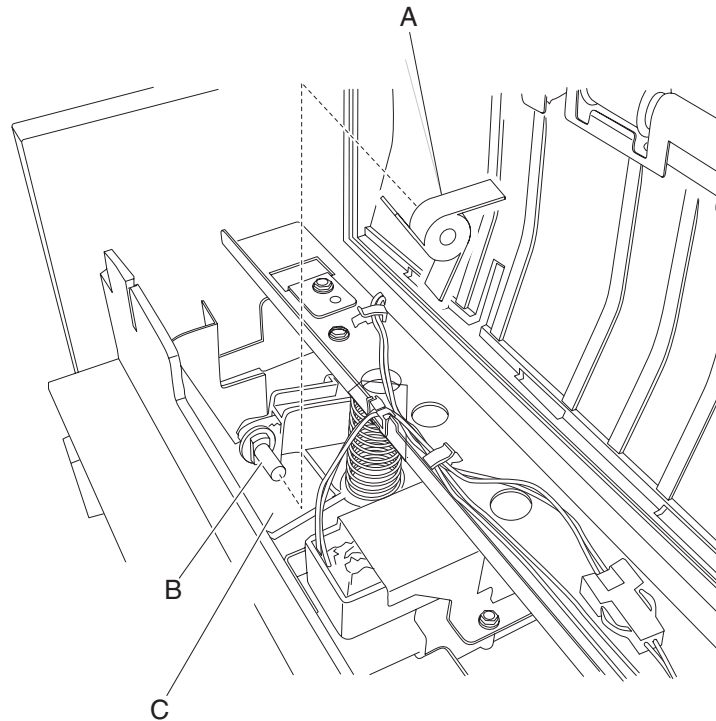

Sub paddle drive shaft assembly removal

1. Open the finisher front door assembly.
2. Remove the rear upper cover. See **“Rear upper cover removal” on page 4-24.**
3. Remove the media eject unit assembly. See **“Media eject unit assembly removal” on page 4-59.**
4. Loosen the screw securing the knob (A) to the sub paddle drive shaft assembly (B) on the front of the finisher.
5. Remove the knob (A).
6. Remove the one e-clip securing the sub paddle drive shaft assembly (B).
7. Remove the bushing (C).

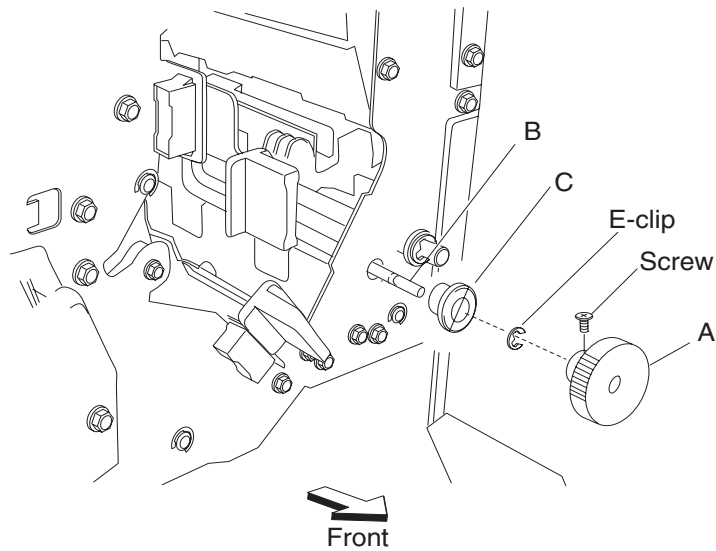

8. Loosen the two screws securing the belt tensioner bracket (D) to the rear of the finisher.
9. Release the hook of the sub paddle drive gear 23T (E) from the sub paddle drive shaft assembly (B).
10. Remove the sub paddle drive gear 23T (E).
11. Remove the e-clip and the 6 mm bushing (C).
12. Move the sub paddle drive shaft assembly (B) toward the rear of the finisher and outward.
13. Remove the sub paddle drive shaft assembly (B).

Replacement notes:

- The tension of the belt (exit) (F) is automatically adjusted by the force of the spring attached to the belt tensioner bracket (D).
- Tighten the two screws in the order shown.

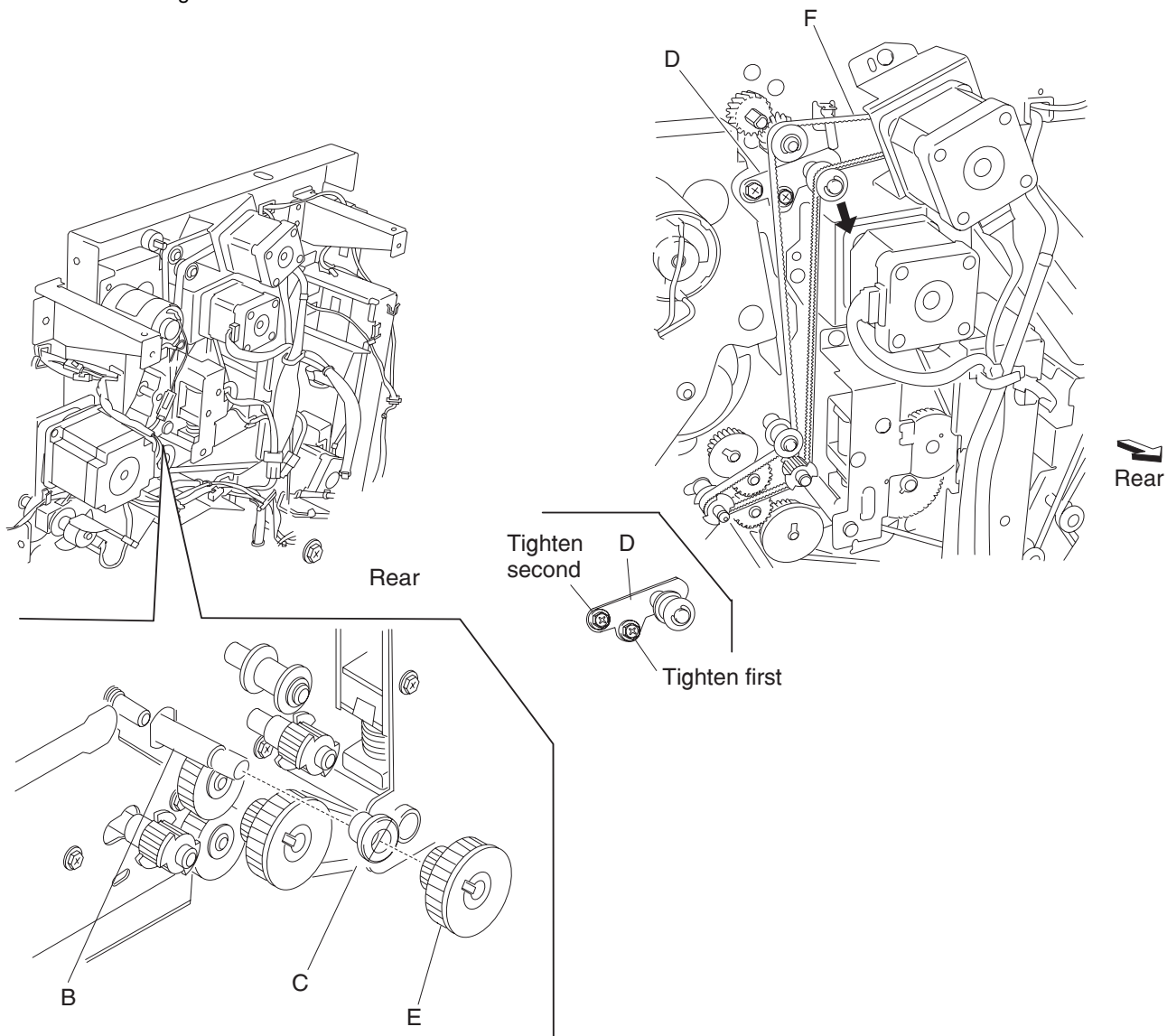

Media eject clamp motor assembly removal

1. Remove the rear upper cover. See **“Rear upper cover removal”** on page 4-24.
2. Remove the upper media bin assembly. See **“Upper media bin assembly removal”** on page 4-20.
3. Remove the two media eject unit springs (A) attached to the media eject unit assembly (B) by pushing them downward.

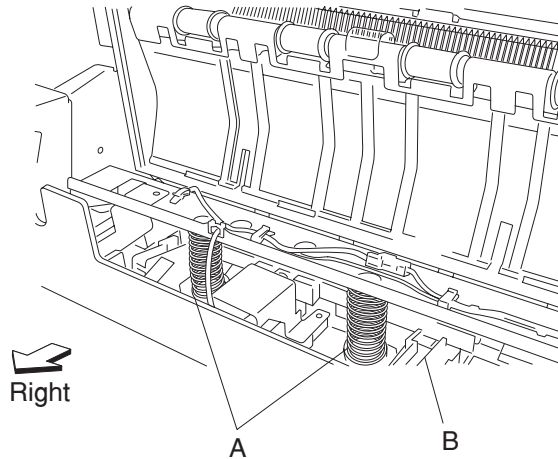

4. Disconnect the connector from the media eject clamp motor (C).
5. Disconnect the connector from the sensor (media eject clamp HP) (D).
6. Remove the three screws securing the bracket (E) to the finisher.
7. Remove the bracket (E).

Note: When removing the bracket, turn the media eject clamp gear 70T (F) so that it does not interact with the sensor (media eject clamp HP) (D).

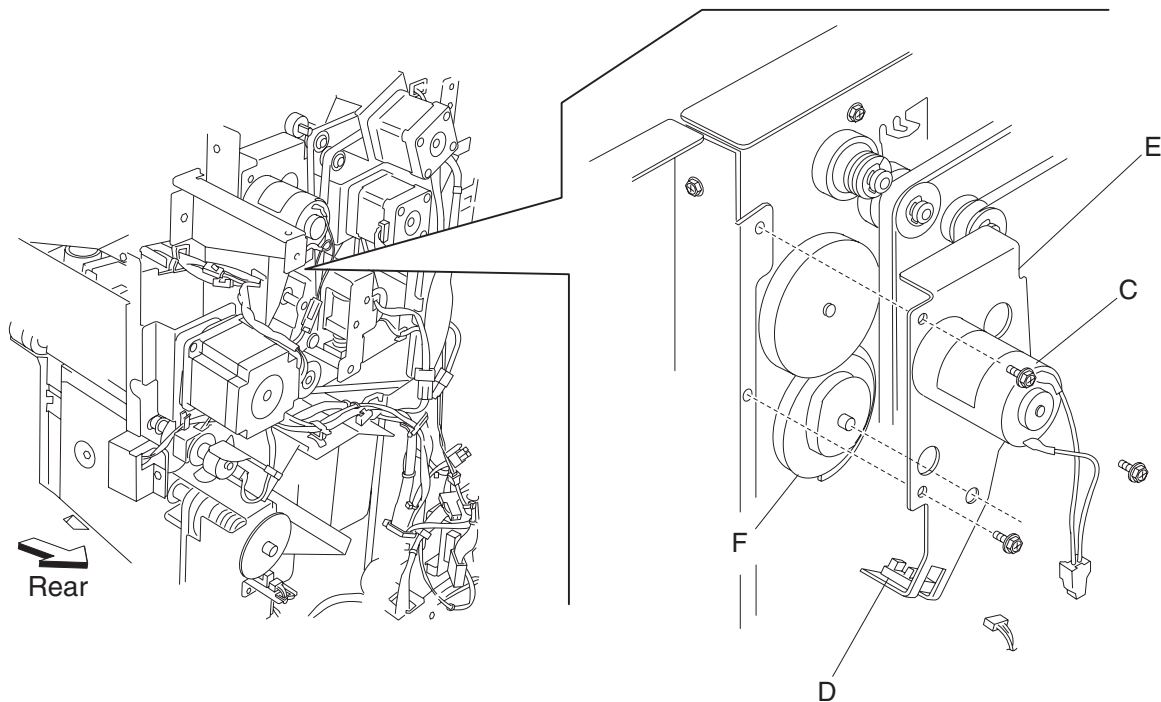

8. Remove the two screws securing the media eject clamp motor to the bracket (E).
9. Remove the media eject clamp motor (C).

Replacement note: When replacing the bracket, turn the media eject clamp gear 70T (F) so that it interacts with the sensor (media eject clamp HP).

Sensor (media eject clamp HP) removal

1. Remove the rear upper cover. See **“Rear upper cover removal”** on page 4-24.
2. Remove the upper media bin assembly. See **“Upper media bin assembly removal”** on page 4-20.
3. Remove the two media eject unit springs attached to the media eject unit assembly by pushing them downward.

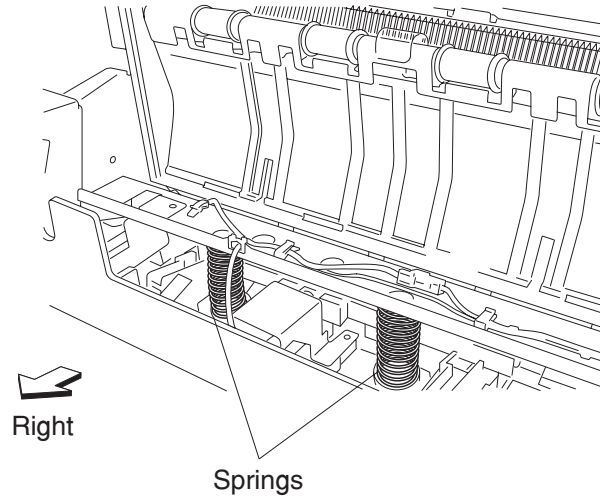

4. Remove the media eject clamp motor assembly. See **“Media eject clamp motor assembly removal”** on page 4-66.
5. Release the hooks of the sensor (media eject clamp HP) (A) from the bracket (B).
6. Remove the sensor (media eject clamp HP) (A).

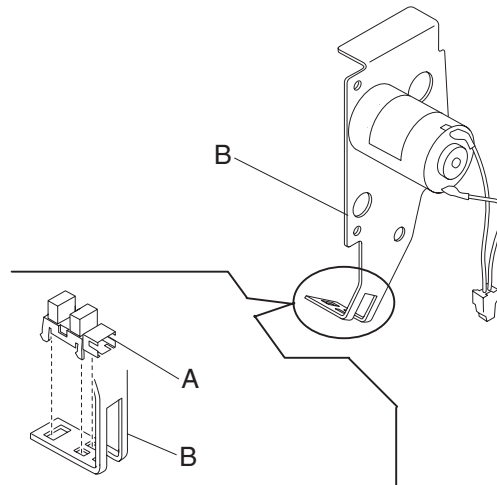

Switch (eject cover interlock) removal

1. Remove the upper media bin assembly. See **“Upper media bin assembly removal”** on page 4-20.
2. Disconnect the connector from the switch (eject cover interlock) (A).
3. Release the harness from the two clamps.
4. Remove the screw securing the bracket (B) to the finisher.
5. Remove the bracket (B) from the square hole in the finisher.
6. Remove the two screws securing the switch (eject cover interlock) (A) from the bracket (B).

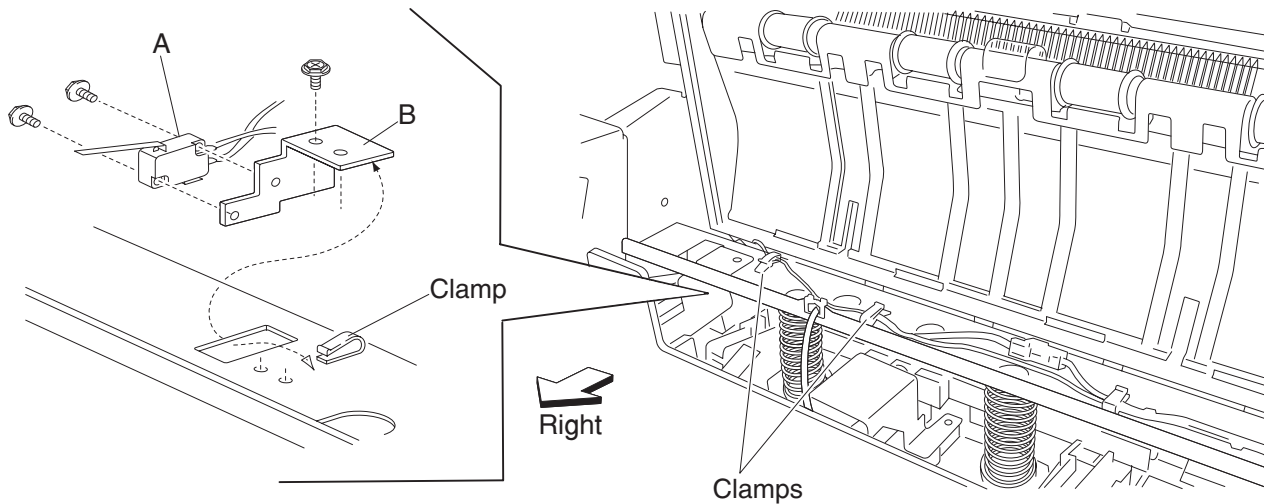

7. Remove the switch (eject cover interlock) (A).

Replacement note: Make sure the media eject unit assembly (C) properly actuates the switch (media eject interlock) (A) without binding.

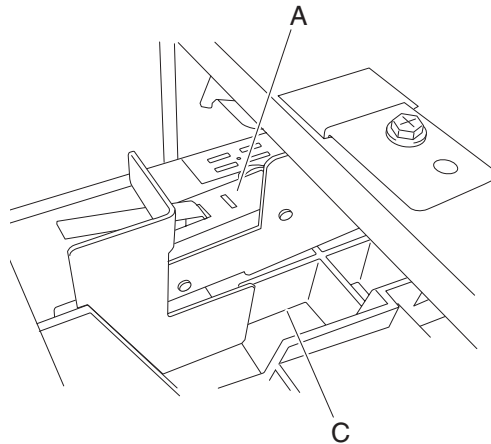

Media compiler unit assembly removal

1. Remove the finisher front door assembly. See **“Finisher front door assembly removal”** on page 4-27.
2. Remove the rear upper cover. See **“Rear upper cover removal”** on page 4-24.
3. Remove the rear lower cover. See **“Rear lower cover removal”** on page 4-23.
4. Remove the upper media bin assembly. See **“Upper media bin assembly removal”** on page 4-20.
5. Remove the upper media bin vertical cover. See **“Right eject cover removal”** on page 4-21.
6. Remove the stapler unit frame. See **“Stapler unit frame removal”** on page 4-54.
7. Remove the media eject clamp motor assembly. See **“Media eject clamp motor assembly removal”** on page 4-66.
8. Remove the media eject unit assembly. See **“Media eject unit assembly removal”** on page 4-59.
9. Remove the media eject motor assembly. See **“Media eject motor assembly removal”** on page 4-78.
10. Loosen the four screws securing the plate (A) to the finisher.
11. Move the plate to the right and outward.

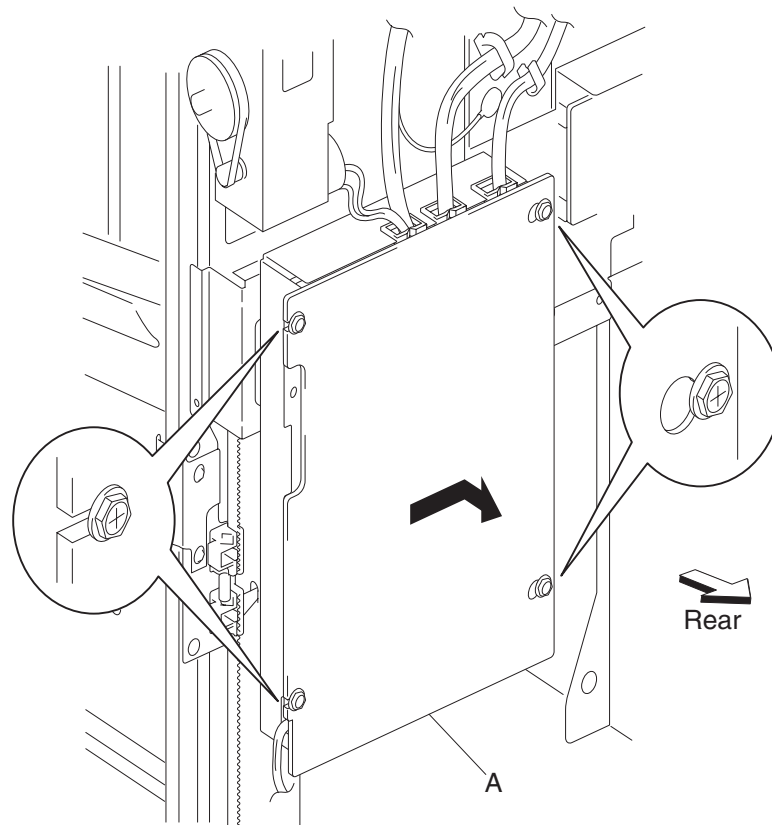

12. Remove the plate.

- 13. Disconnect the connector P8309 from the finisher controller card assembly (B).
- 14. Release the harness from the clamps.

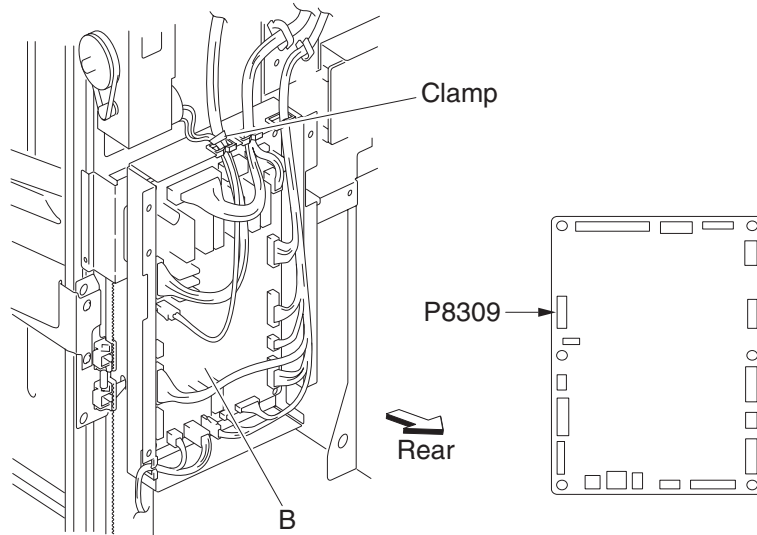

- 15. Remove the screw securing the media compiler unit assembly (C) to the finisher. This screw is found inside the finisher.

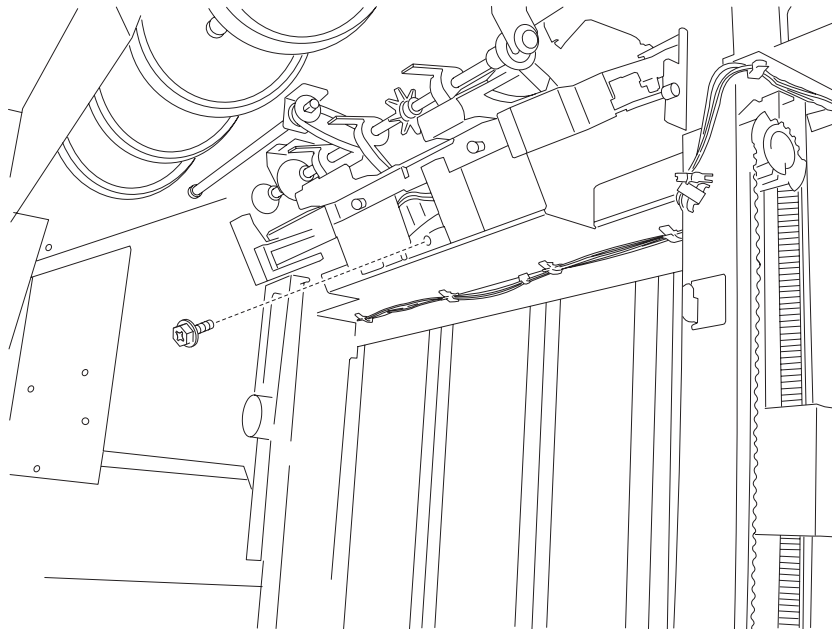

Inside view

- 16. Release the media compiler assembly (C) by pushing the front lock and the rear lock inward to release the front boss and the rear boss from the finisher.

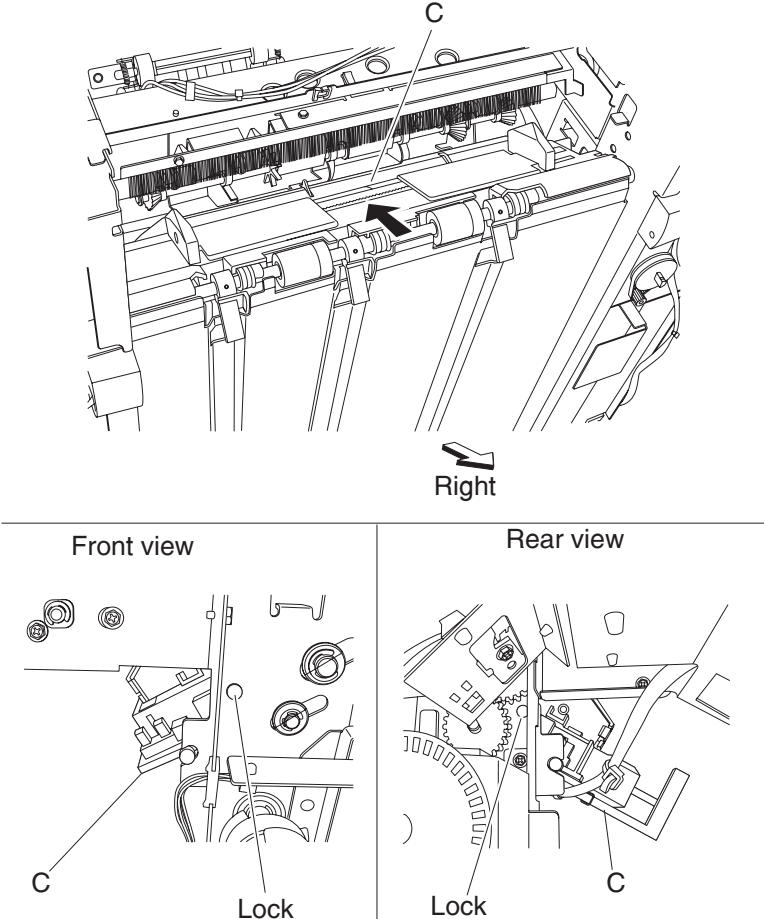

- 17. Remove the harness from any additional parts.
- 18. Remove the media compiler unit assembly through the inside of the finisher and out the front.

Sensor (front tamper HP) and sensor (rear tamper HP) removals

1. Remove the finisher front door assembly. See **“Finisher front door assembly removal” on page 4-27.**
2. Remove the rear upper cover. See **“Rear upper cover removal” on page 4-24.**
3. Remove the rear lower cover. See **“Rear lower cover removal” on page 4-23.**
4. Remove the upper media bin assembly. See **“Upper media bin assembly removal” on page 4-20.**
5. Remove the upper media bin vertical cover. See **“Right eject cover removal” on page 4-21.**
6. Remove the stapler unit frame. See **“Stapler unit frame removal” on page 4-54.**
7. Remove the media eject clamp motor assembly. See **“Media eject clamp motor assembly removal” on page 4-66.**
8. Remove the media eject unit assembly. See **“Media eject unit assembly removal” on page 4-59.**
9. Remove the media eject motor assembly. See **“Media eject motor assembly removal” on page 4-78**
10. Remove the media compiler unit assembly. See **“Media compiler unit assembly removal” on page 4-69.**
11. Disconnect the connector from the sensor (front tamper HP) (A) or the sensor (rear tamper HP) (B).
12. Release the hooks securing the sensor (front tamper HP) (A) or the sensor (rear tamper HP) (B) from the media compiler unit assembly (C).
13. Remove the sensor(s).
Note: The sensors are identical.

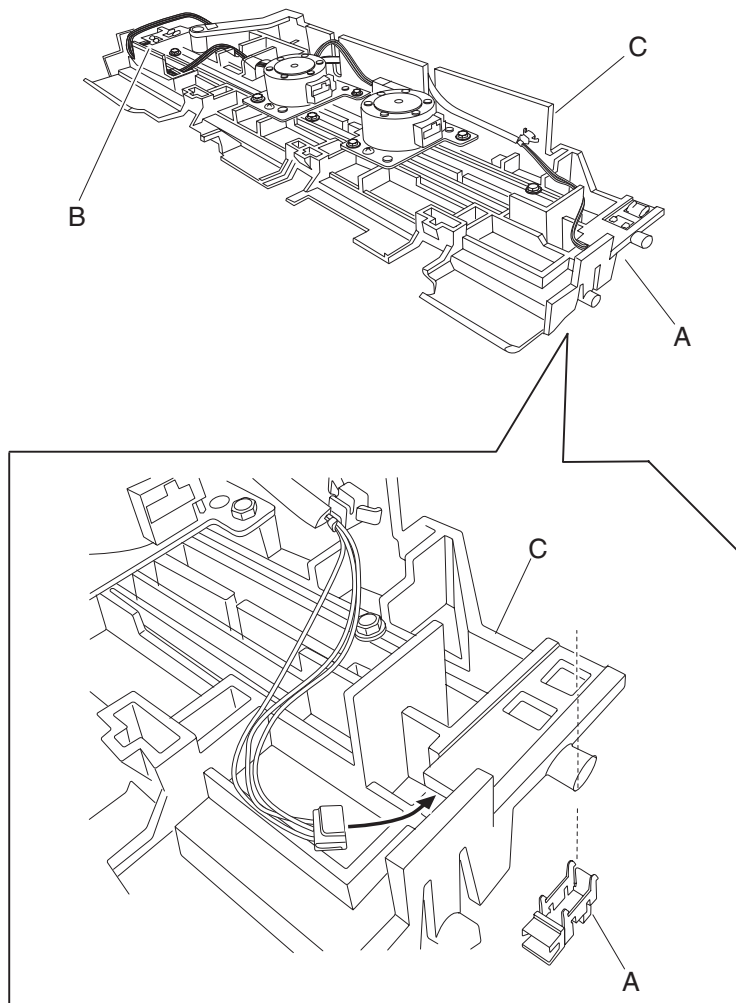

Sensor (compiler media in) removal

1. Remove the finisher front door assembly. See “**Finisher front door assembly removal**” on page 4-27.
2. Remove the rear upper cover. See “**Rear upper cover removal**” on page 4-24.
3. Remove the rear lower cover. See “**Rear lower cover removal**” on page 4-23.
4. Remove the upper media bin assembly. See “**Upper media bin assembly removal**” on page 4-20.
5. Remove the upper media bin vertical cover. See “**Right eject cover removal**” on page 4-21.
6. Remove the stapler unit frame. See “**Stapler unit frame removal**” on page 4-54.
7. Remove the media eject clamp motor assembly. See “**Media eject clamp motor assembly removal**” on page 4-66.
8. Remove the media eject unit assembly. See “**Media eject unit assembly removal**” on page 4-59.
9. Remove the media eject motor assembly. See “**Media eject motor assembly removal**” on page 4-78
10. Remove the media compiler unit assembly. See “**Media compiler unit assembly removal**” on page 4-69.
11. Disconnect the connector from the sensor (compiler media in) (A).
12. Release the hooks securing the sensor (compiler media in) (A) to the compiler unit assembly (B).
13. Move the compiler media present actuator (C) downward as shown.

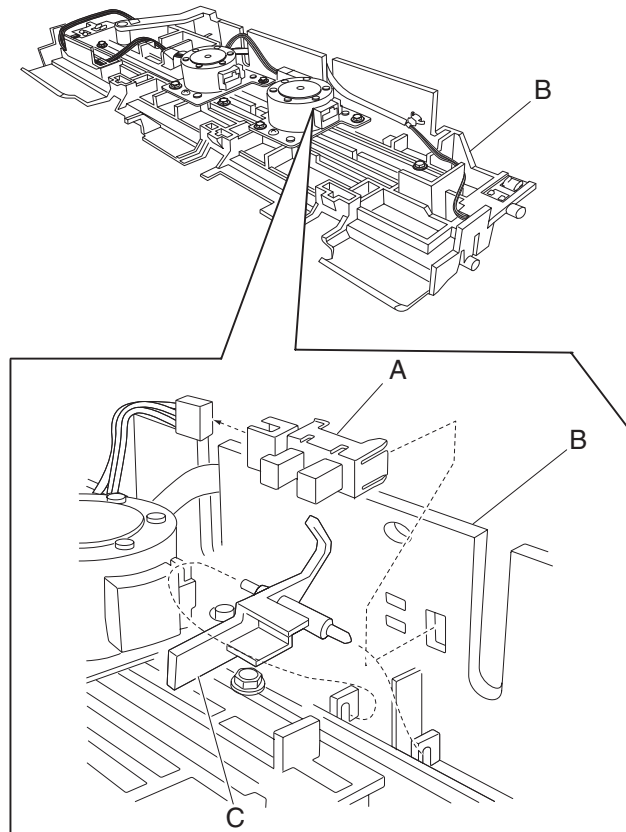

14. Remove the sensor (compiler media present) (A).

Media eject shaft assembly removal

1. Remove the finisher front door assembly. See **“Finisher front door assembly removal” on page 4-27.**
2. Remove the rear upper cover. See **“Rear upper cover removal” on page 4-24.**
3. Move the slip clutch gear 24T (A) toward the rear as shown to disengage the stacker bin (B).
4. Move the stacker bin down as shown to its lowest position after being disengaged.
Note: Make sure the stacker bin is at its lowest position before continuing.
5. Remove the upper media bin assembly. See **“Stacker media bin assembly removal” on page 4-22.**
6. Remove the four screws securing the right panel (C) to the finisher.

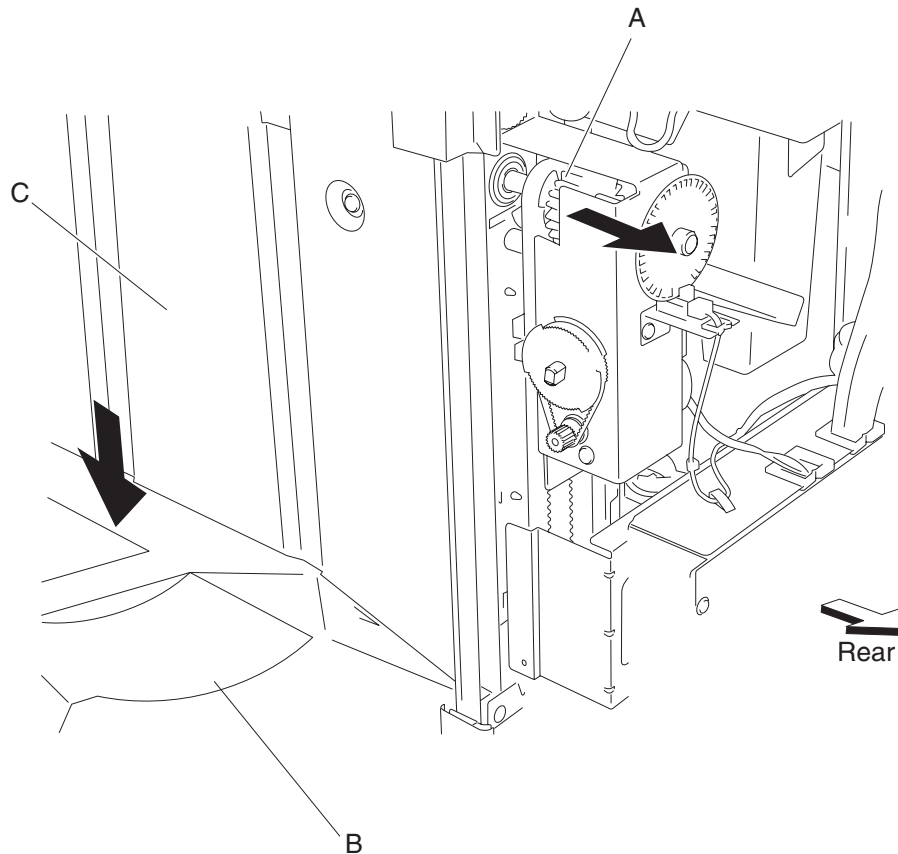

7. Remove the media eject motor assembly. See **“Media eject motor assembly removal” on page 4-78.**
8. Release the hook of the media eject shaft gear 39T (D) from the media eject shaft assembly (E).
9. Remove the media eject shaft gear 39T (D).
10. Remove the 6 mm bushing (F).
11. Remove the e-clip with a prying tool securing the media eject shaft assembly (E) to the rear of the finisher.
12. Remove the 8 mm bushing (G).
13. Remove the two e-clips securing the media eject shaft assembly (E) to the front of the finisher.
14. Remove the 6 mm bushing (F) and the 8 mm bushing (G).

15. Move the media eject shaft assembly toward the rear and outward as shown.

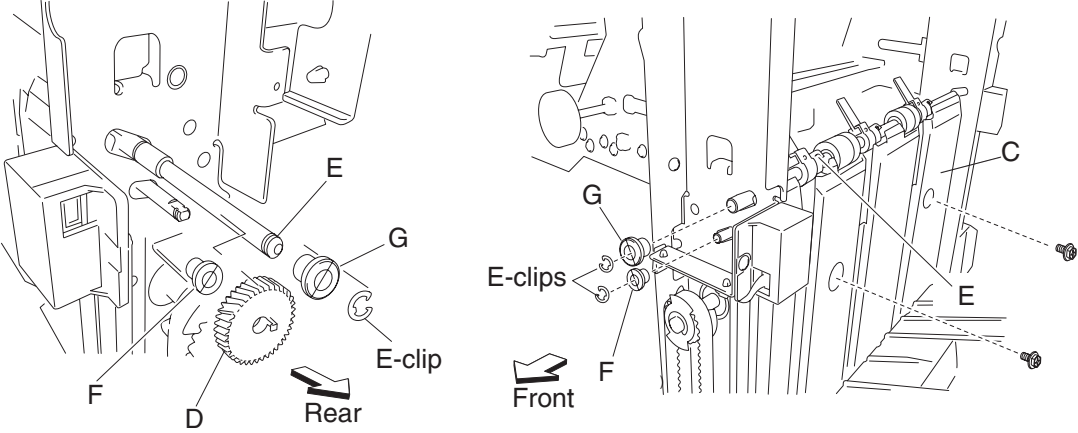

16. Remove the media eject shaft assembly (E).

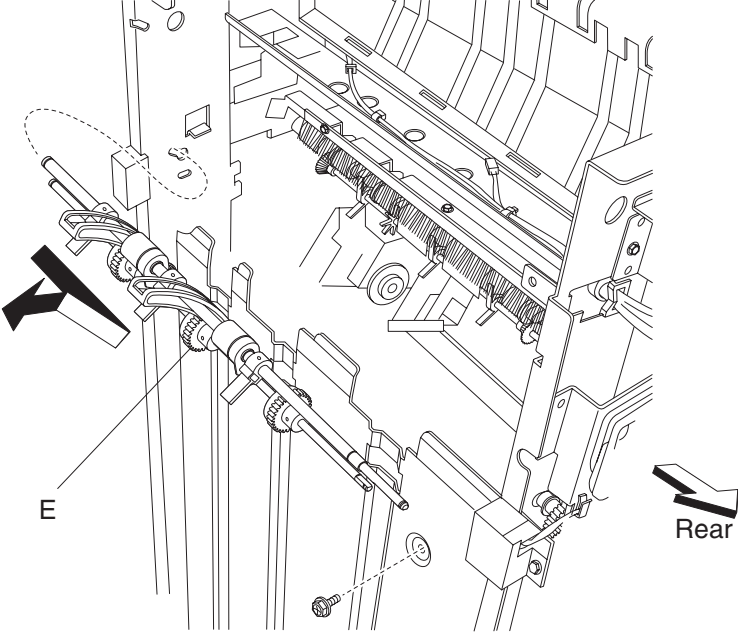

Clamp paddle removal

1. Remove the finisher front door assembly. See **“Finisher front door assembly removal”** on page 4-27.
2. Remove the rear upper cover. See **“Rear upper cover removal”** on page 4-24.
3. Remove the media eject shaft assembly. See **“Media eject shaft assembly removal”** on page 4-74.
4. Remove the three clamp paddles (A) by sliding them out of the media eject shaft assembly (B).

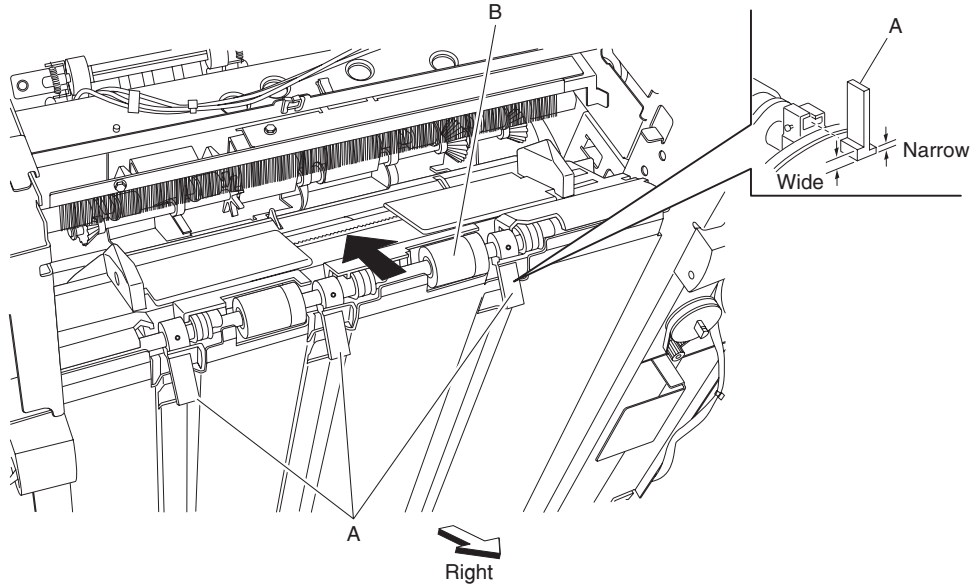

Replacement note: Replacement is easier if you lightly moisten the rubber surface of the paddles with water.

Media eject clutch removal

1. Remove the rear upper cover. See **“Rear upper cover removal”** on page 4-24.
2. Disconnect the connector from the sensor (media eject shaft HP) (A).
3. Release the harness from the clamp.
4. Disconnect the connector from the media eject clutch (B).
5. Release the harness from the clamp.
6. Release the hook securing the media eject clutch actuator (C) to the media eject clutch (B).
7. Remove the screw securing the spring clamp (D) to the finisher.

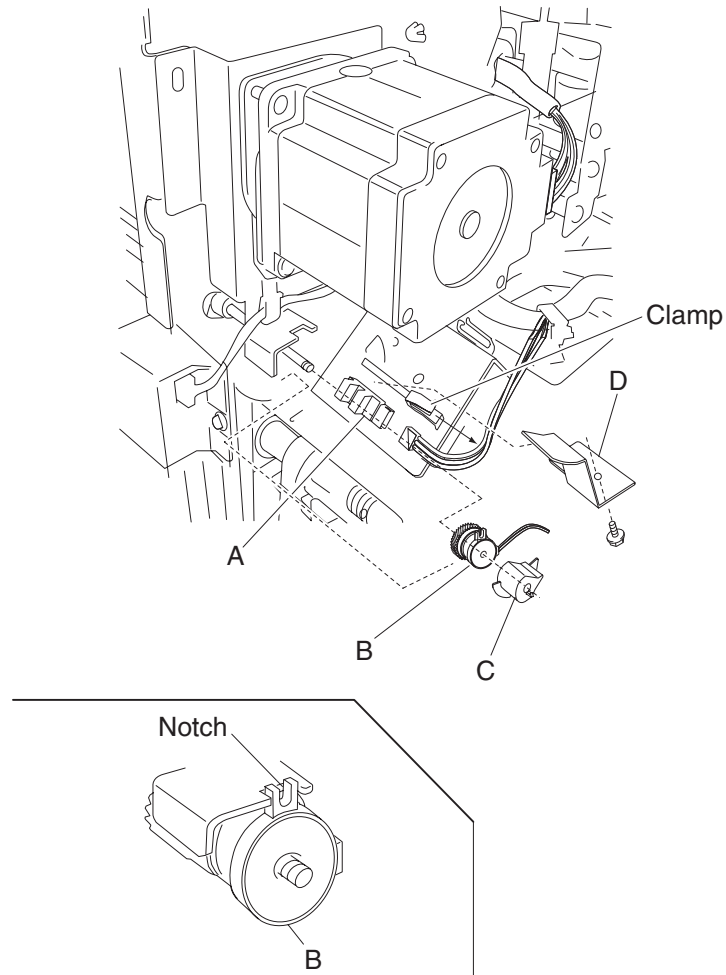

8. Remove the spring clamp (D).
9. Remove the media eject clutch actuator (C).
10. Remove the media eject clutch (B).

Installation note: Make sure the hook on the media eject clutch is placed in the notch of the bracket.

Media eject motor assembly removal

1. Remove the rear upper cover. See **“Rear upper cover removal”** on page 4-24.
2. Remove the media eject clutch. See **“Media eject clutch removal”** on page 4-77.
3. Disconnect the connector from the media eject motor assembly (A).
4. Disconnect the connector from the sensor (media bin level 2) (B).
5. Remove the three screws securing the media eject motor assembly (A).

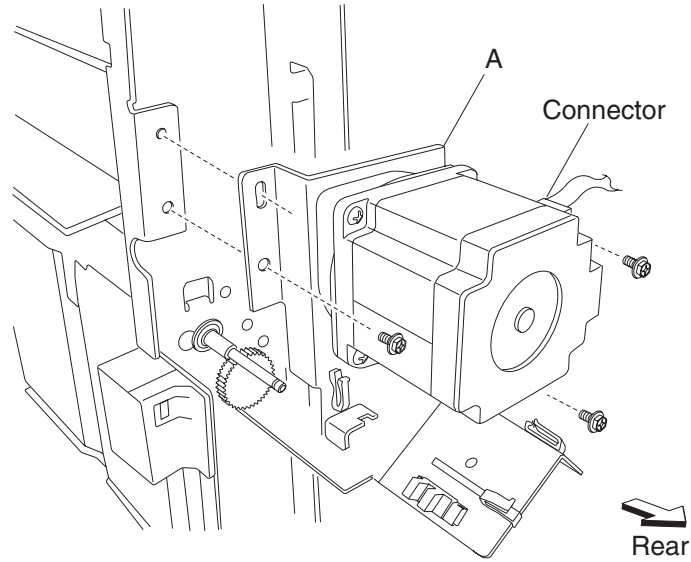

6. Remove the media eject motor assembly (A).
7. Remove any remaining harnesses from the clamps.

Sensor (media eject shaft HP) removal

1. Remove the rear upper cover. See **“Rear upper cover removal”** on page 4-24.
2. Disconnect the connector from the sensor (media eject shaft HP) (A).
3. Rotate the media eject clutch actuator (B) by hand so it clears the sensor (media eject shaft HP) (A).
4. Release the hooks securing the sensor (media eject shaft HP) (A) to the bracket (C).

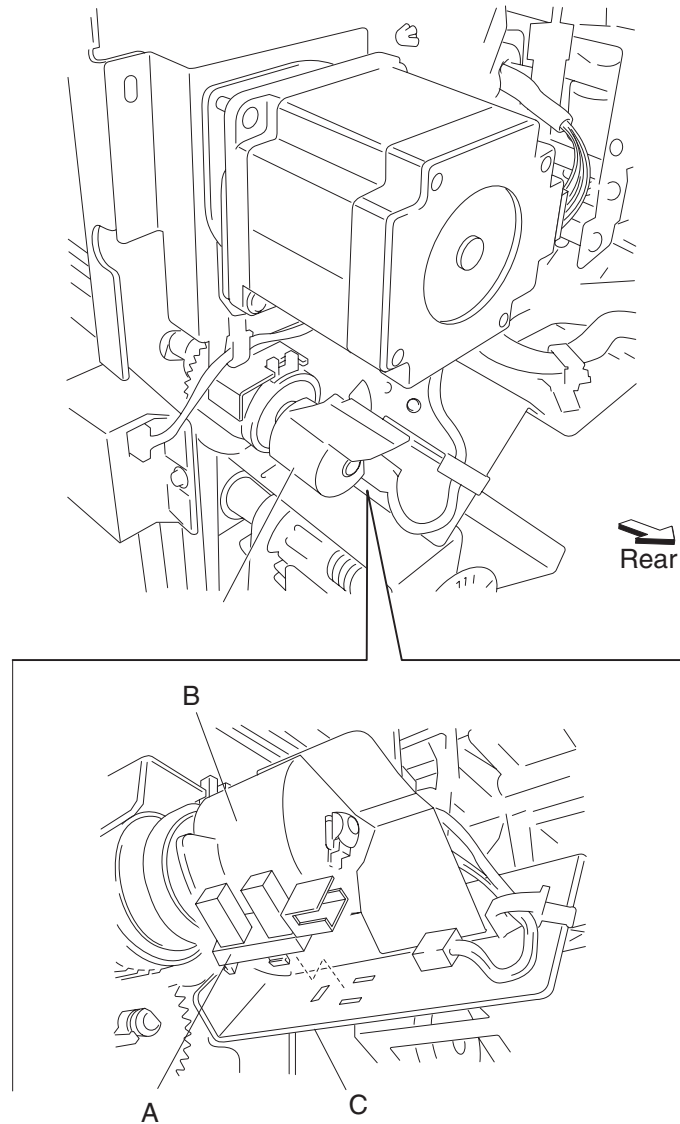

5. Remove the sensor (media eject shaft HP) (A).

Sensor (lower media exit) removal

1. Open the finisher front door assembly.
2. Remove the upper media bin assembly. See **“Upper media bin assembly removal”** on page 4-20.
3. Disconnect the connector from the sensor (lower media exit) (A).
4. Remove the harness from the clamps.
5. Remove the two screws securing the bracket (B) to the finisher.

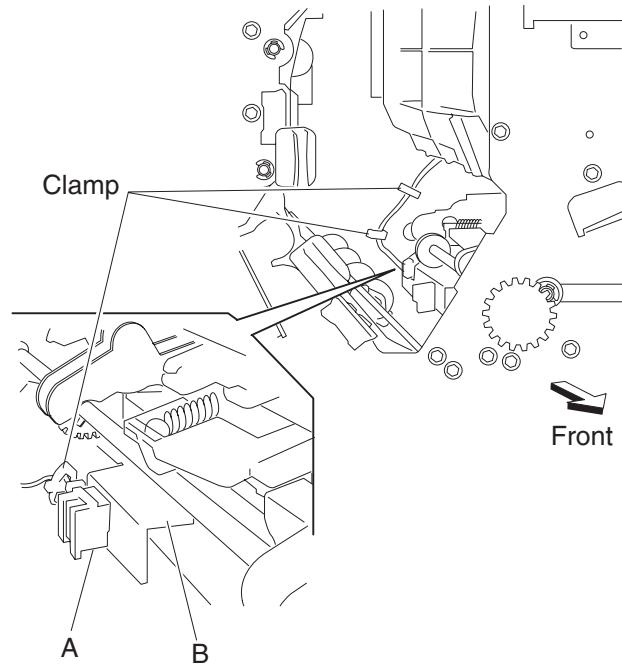

Note: The upper media bin vertical cover (C) has slots that make access to the screws easier, as shown.

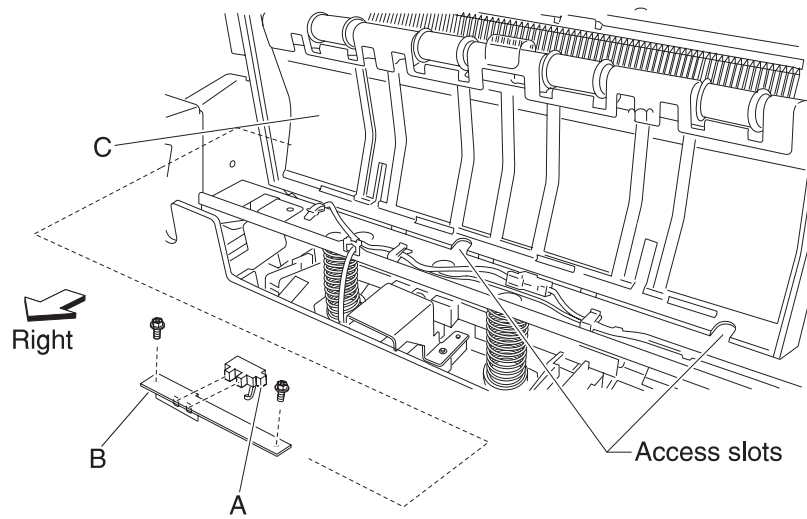

6. Remove the bracket (B).
7. Release the hooks securing the sensor (lower media exit) (A) to the bracket.
8. Remove the sensor (lower media exit) (A).

Lower media exit roll assembly removal

1. Remove the finisher front door assembly. See **“Finisher front door assembly removal”** on page 4-27.
2. Remove the rear upper cover. See **“Rear upper cover removal”** on page 4-24.
3. Remove the upper media bin assembly. See **“Upper media bin assembly removal”** on page 4-20.
4. Remove upper media bin vertical cover. See **“Right eject cover removal”** on page 4-21.
5. Remove the stapler unit frame. See **“Stapler unit frame removal”** on page 4-54.
6. Remove the media eject clamp motor assembly. See **“Media eject clamp motor assembly removal”** on page 4-66.
7. Remove the media eject unit assembly. See **“Media eject unit assembly removal”** on page 4-59.
8. Remove the media compiler unit assembly. See **“Media compiler unit assembly removal”** on page 4-69.
9. Remove the media eject motor assembly. See **“Media eject motor assembly removal”** on page 4-78.
10. Remove the media eject shaft assembly. See **“Media eject shaft assembly removal”** on page 4-74.
11. Remove the main paddle shaft assembly. See **“Paddle and roll exit assembly removal”** on page 4-86.
12. Loosen the two screws securing the belt tensioner bracket (A) to the finisher, and move it down in the direction of the arrow.
13. Remove the belt (exit) (B) from the lower exit roll drive pulley 20T (C).

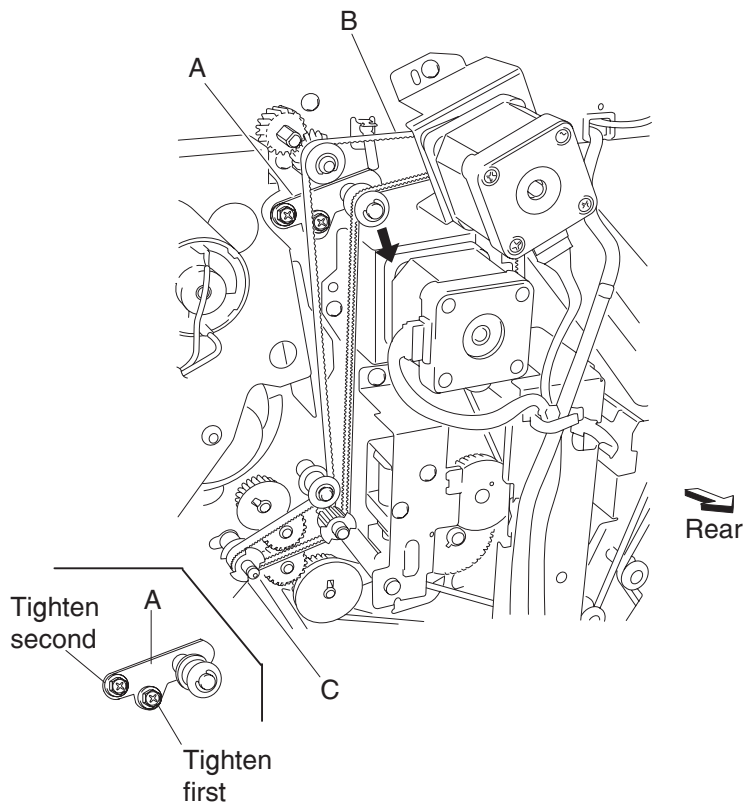

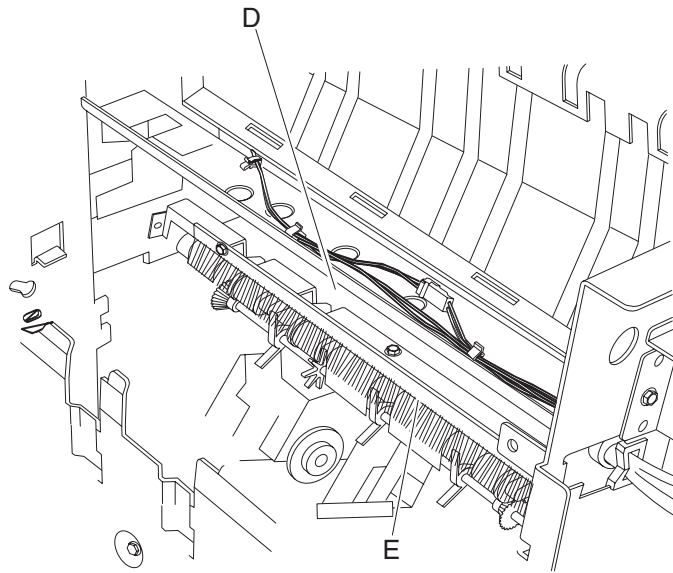

Front view

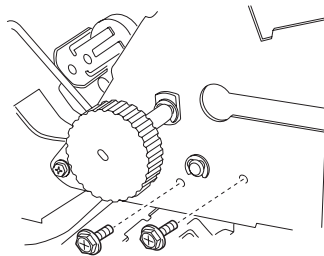

Rear view

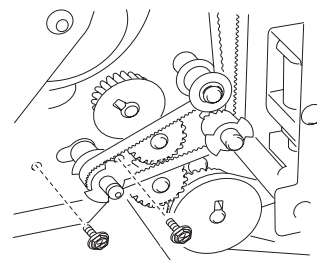

14. Release the hook of the lower exit roll drive pulley 20T (C) from the lower media exit roll assembly (F).
15. Remove the lower exit roll drive pulley 20T (C).

16. Remove the 6 mm ball bearing (G).

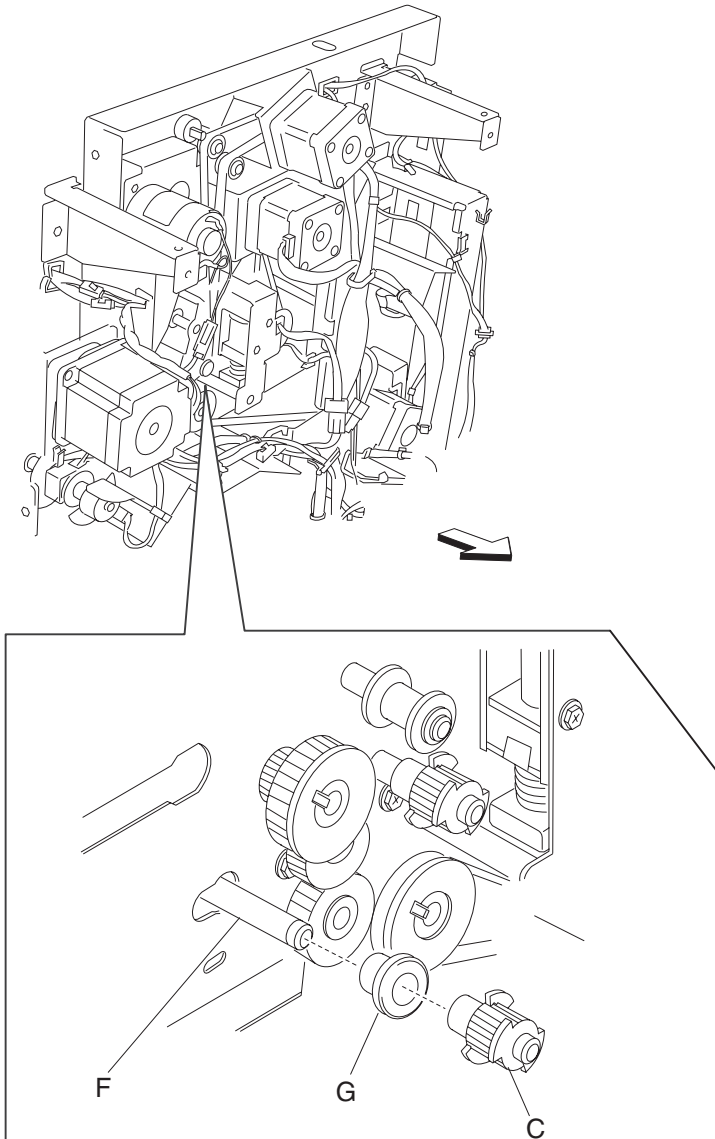

17. Remove the e-clip on the front of the finisher with a prying tool securing the lower media exit roll assembly (F) to the finisher.

18. Remove the 6 mm bushing (H).

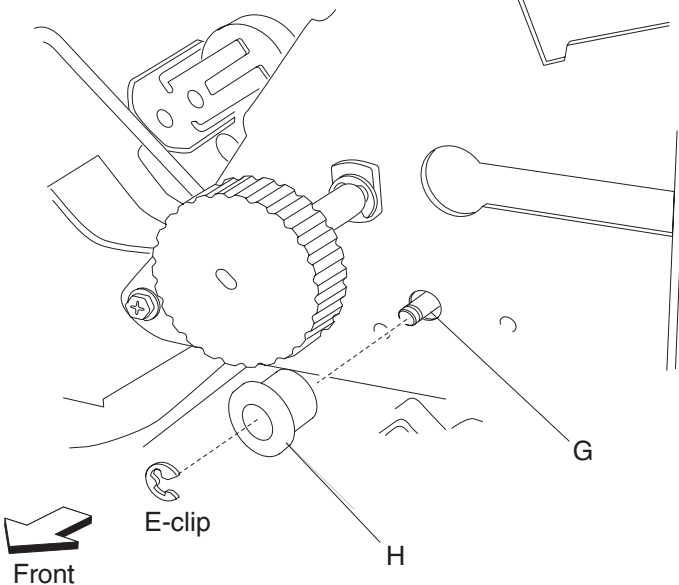

19. Move the lower media exit roll assembly (F) towards the rear and outward, as shown.

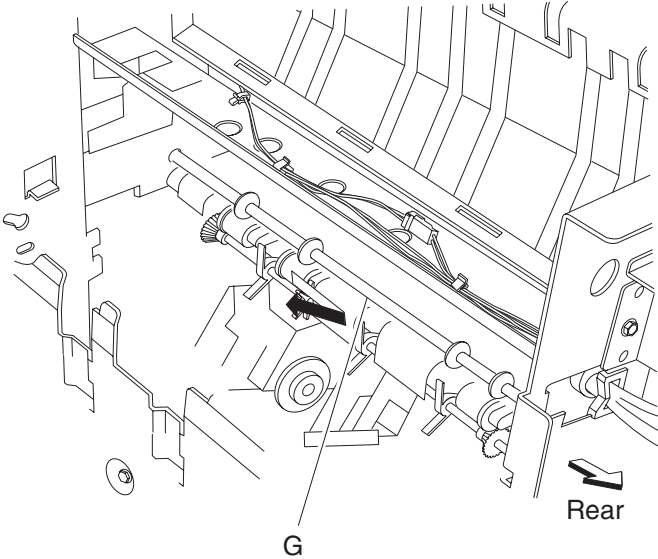

20. Remove the lower media exit roll assembly (F).

Paddle and roll exit assembly removal

1. Remove the finisher front door assembly. See **“Finisher front door assembly removal”** on page 4-27.
2. Remove the rear upper cover. See **“Rear upper cover removal”** on page 4-24.
3. Remove the rear lower cover. See **“Rear lower cover removal”** on page 4-23.
4. Remove the upper media bin assembly. See **“Upper media bin assembly removal”** on page 4-20.
5. Remove the upper media bin vertical cover. See **“Right eject cover removal”** on page 4-21.
6. Remove the stapler unit frame. See **“Stapler unit frame removal”** on page 4-54.
7. Remove the media eject clamp motor assembly. See **“Media eject clamp motor assembly removal”** on page 4-66.
8. Remove the media eject unit assembly. See **“Media eject unit assembly removal”** on page 4-59.
9. Remove the media compiler unit assembly. See **“Media compiler unit assembly removal”** on page 4-69.
10. Remove the media eject motor assembly. See **“Media eject motor assembly removal”** on page 4-78.
11. Remove the media eject shaft assembly. See **“Media eject shaft assembly removal”** on page 4-74.
12. Loosen the two screws securing the belt tensioner bracket (A) to the finisher, and move it down, as shown.
13. Remove the belt (exit) (B) from the lower exit roll drive pulley 20T (C).

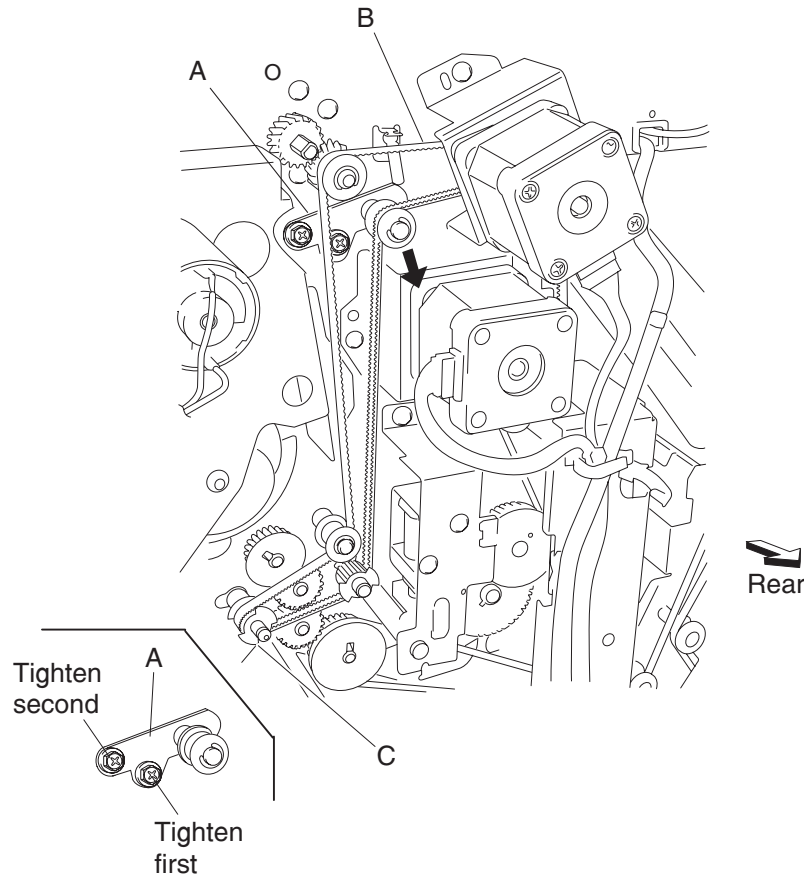

14. Loosen the two screws securing the belt tensioner bracket (D) to the finisher and move it downward, as shown.
15. Remove the belt (paddle/entrance) (E) from the main paddle drive pulley/gear 44/20T (F).
16. Release the hook from the main paddle shaft drive pulley 17T (G) inside the finisher.
17. Remove the main paddle shaft drive pulley 17T (G).
Note: The belt (H) will become attached.

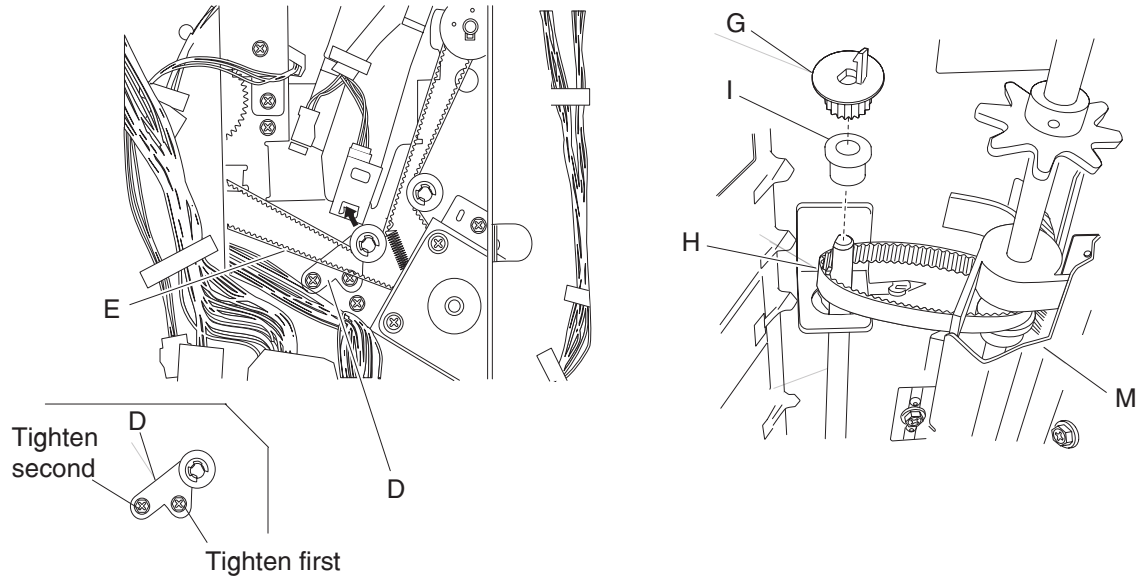

18. Remove the 6 mm bushing (I).
19. Release the hook of the main paddle drive pulley/gear 44/20T (F) from the shaft (J).
20. Remove the main paddle drive pulley/gear 44/20T (F).
21. Remove the 6 mm bushing (K).
22. Remove the main paddle idler gear 23T right (L).
23. Remove the two front and the two rear screws securing the main paddle shaft assembly (M).
24. Move the main paddle shaft assembly (M) forward and then downward and outward.

25. Remove the main paddle shaft assembly.

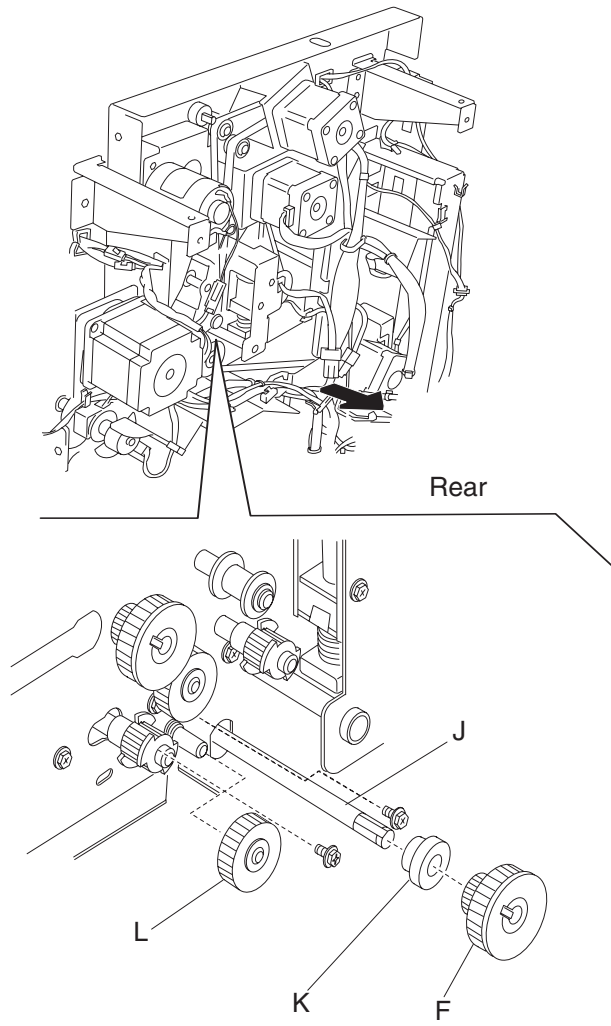

Replacement notes:

- The tension of the belt (exit) (A) and the belt (paddle/entrance) (E) is automatically adjusted by the force of the spring attached to the belt tensioner bracket (A and D).
- Tighten the two screws in the order shown.

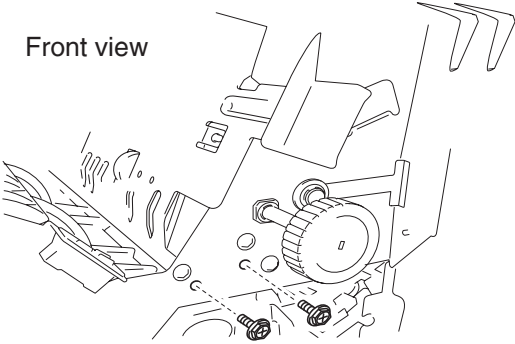
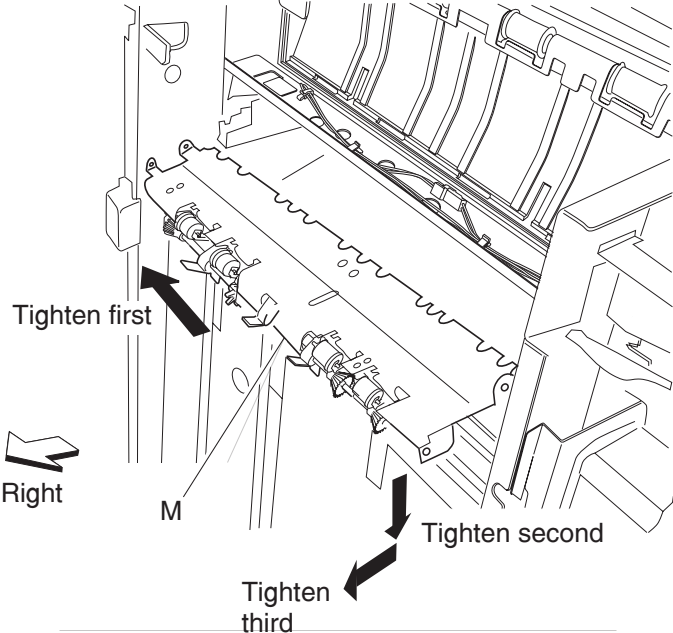

Lower pinch guide assembly removal

1. Open the finisher front door assembly.
2. Open the lower pinch guide assembly (A) by lifting it upward.
3. Remove the screw securing the lower pinch guide assembly (A) to the finisher.
4. Move the lower pinch guide assembly (A) upward and outward.

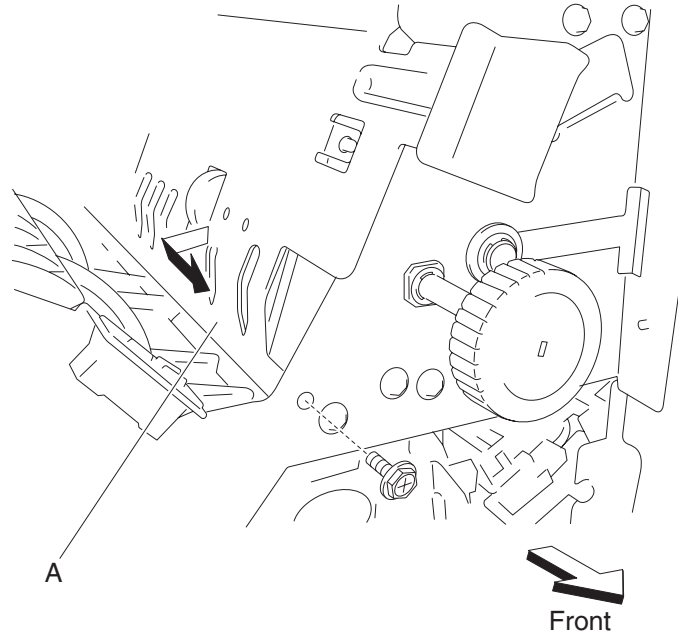

5. Remove the lower pinch guide assembly (A).

Media diverter gate removal

1. Open the finisher front door assembly.
2. Remove the rear upper cover. See **“Rear upper cover removal” on page 4-24.**
3. Open the lower pinch guide assembly (A) to the right.
4. Open the upper pinch guide assembly (B) to the right.
5. Remove the media diverter gate solenoid. See **“Media diverter gate removal” on page 4-91.**
6. Remove the link (C).
7. Move the media diverter gate (D) toward the rear, to the right, and forward, as shown.

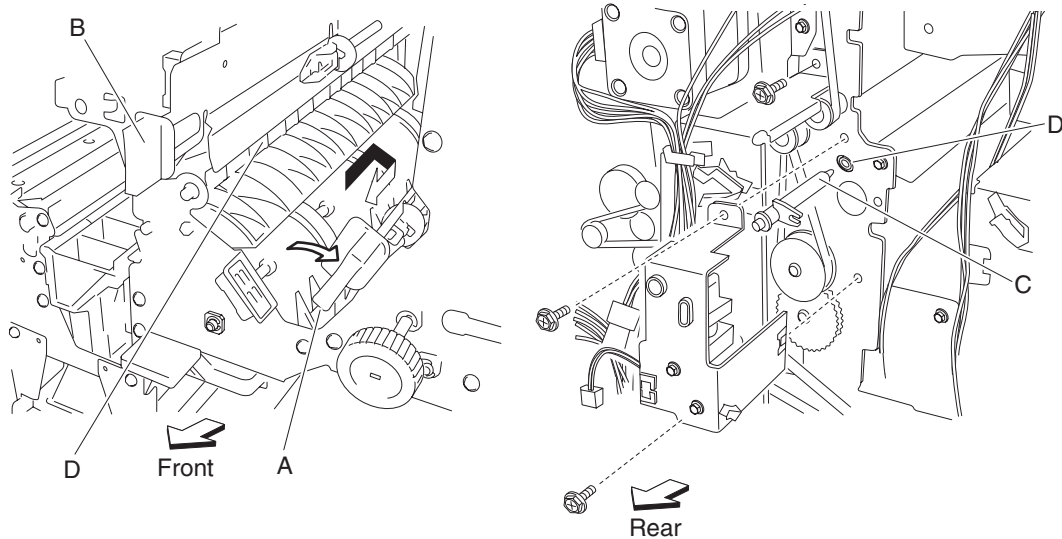

8. Remove the media diverter gate.

Buffer diverter gate removal

1. Open the finisher front door assembly.
2. Move the lower pinch guide assembly (A) to the right.
3. Remove the rear upper cover. See **“Rear upper cover removal” on page 4-24.**
4. Remove the buffer diverter gate solenoid. See **“Media diverter gate solenoid removal” on page 4-102.**
5. Remove the link (D).

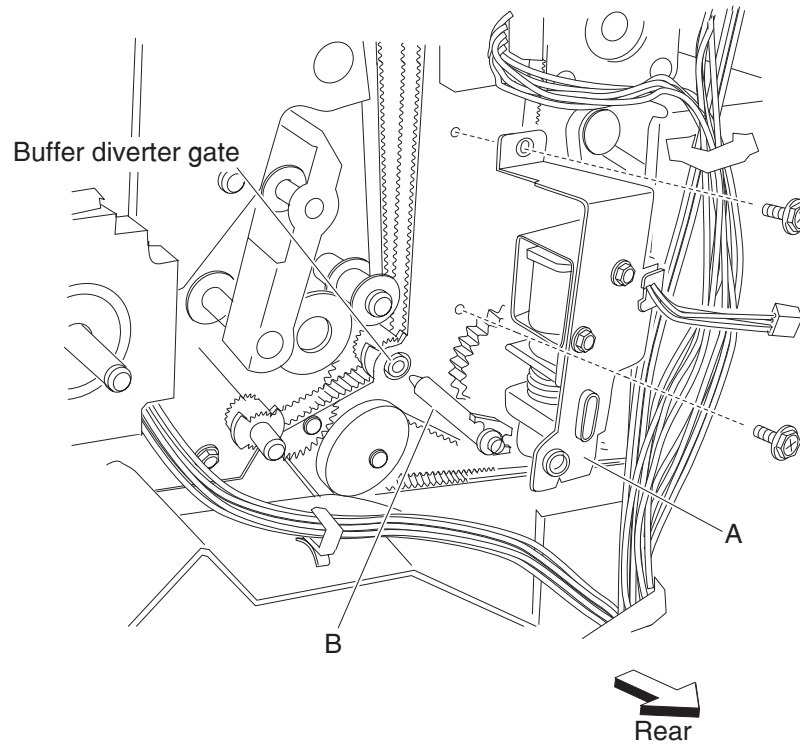

6. Move the buffer diverter gate (C) toward the rear, the left, and then forward, as shown.

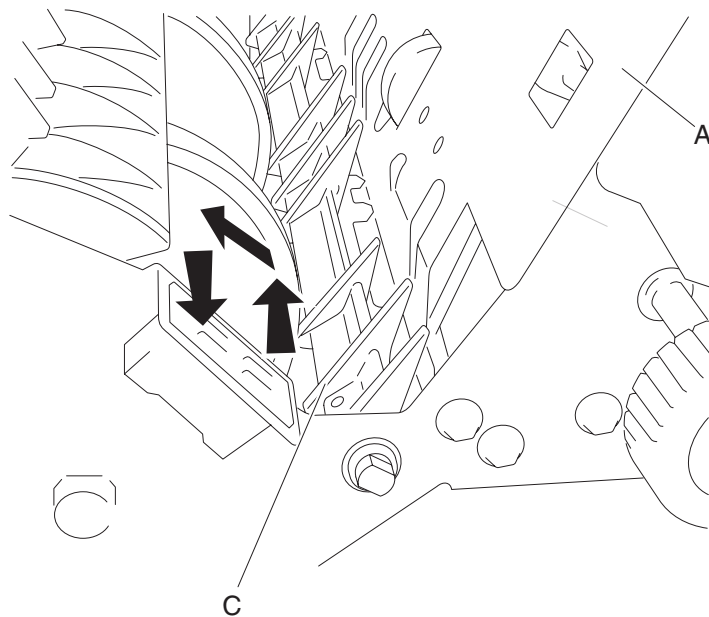

7. Remove the buffer diverter gate (C).

Sensor (buffer path) removal

1. Open the finisher front door assembly.
2. Remove the rear upper cover. See **“Rear upper cover removal” on page 4-24.**
3. Remove the top cover. See **“Top cover removal” on page 4-19.**
4. Remove the left lower cover. See **“Left lower cover removal” on page 4-28.**
5. Remove the left upper cover. See **“Left upper cover removal” on page 4-29.**
6. Remove the punch carriage assembly. See **“Punch carriage assembly removal” on page 4-41.**
7. Disconnect the connector from the sensor (buffer path) (A).
8. Remove the screw securing the bracket (B) to the finisher.

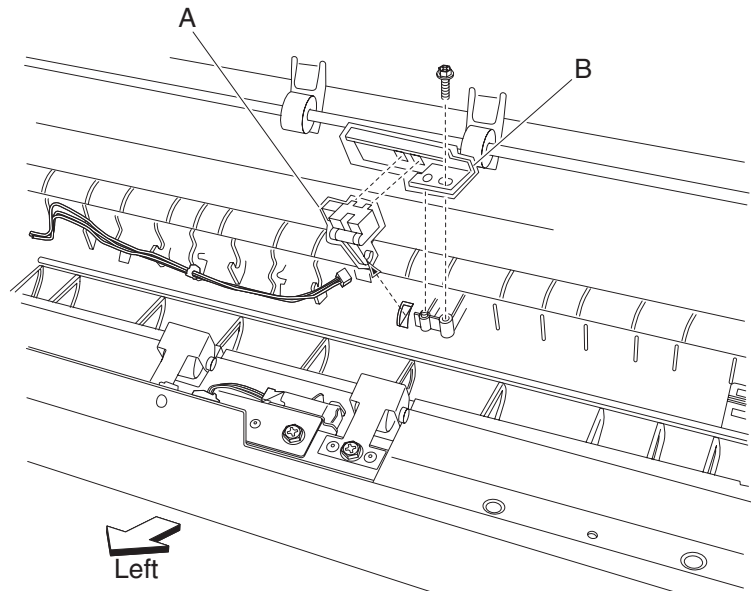

9. Remove the bracket (B).
10. Release the hooks securing the sensor (buffer path) (A) to the bracket (B).
11. Remove the sensor (buffer path) (A).

Buffer roll assembly removal

1. Remove the rear upper cover. See **“Rear upper cover removal”** on page 4-24.
2. Open the finisher front door assembly.
3. Remove the stapler unit cartridge.
4. Move the stapler unit assembly by hand as far to the rear as it will go.
5. Lower the buffer pinch guide assembly (A).
6. Move the lower pinch guide assembly to the right.
7. Position the buffer diverter gate (B) using your finger to its upper most position.

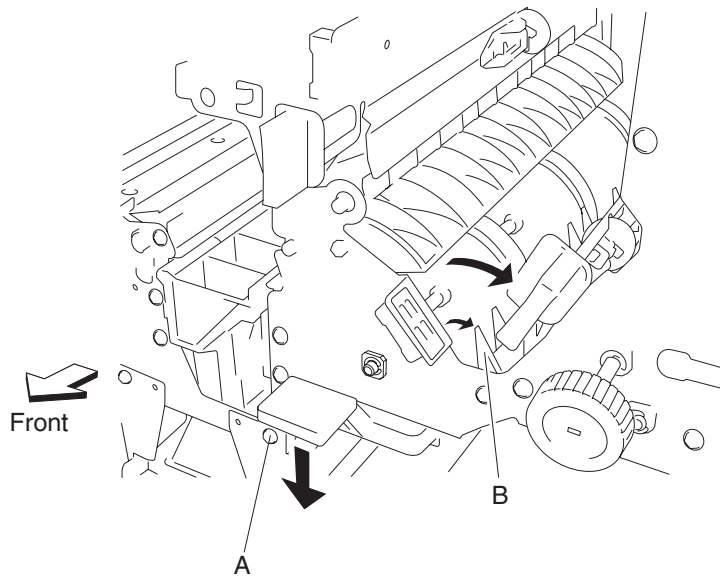

8. Use a prying tool to remove the e-clip securing the buffer roll assembly (C) to the front of the finisher.
9. Remove the 6 mm bushing (D).

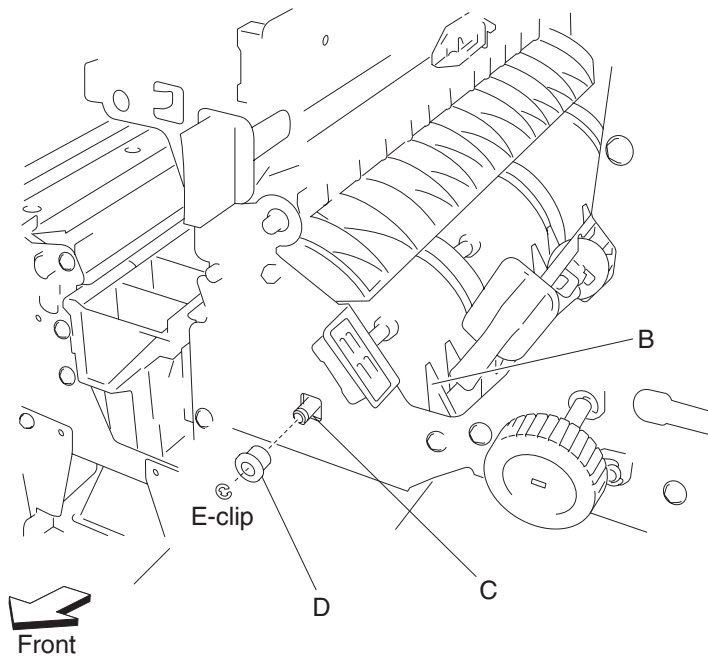

10. Remove the media diverter gate solenoid. See **“Media diverter gate removal”** on page 4-91.

11. Loosen the two screws securing the belt tensioner bracket (E) to the finisher and move it downward, as shown.
12. Remove the belt (buffer/transport) (F) from the buffer roll drive gear 46T (G).

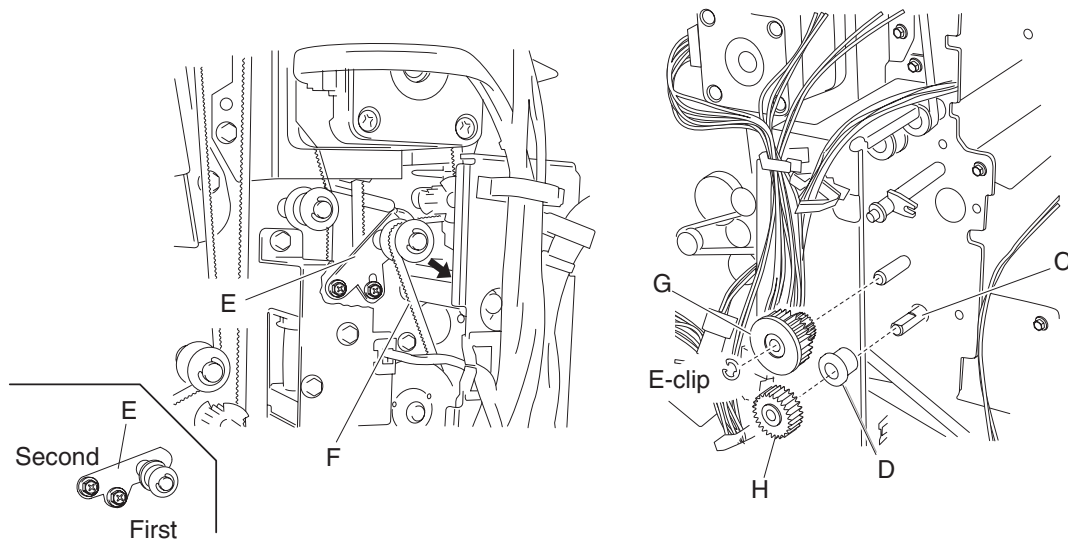

13. Use a prying tool to remove the e-clip securing the buffer roll drive gear 23/53T (G).
14. Remove the buffer roll drive gear 53/23T (G).
15. Release the hook of the buffer roll drive gear 46T (H) from the buffer roll assembly (C).
16. Remove the buffer roll drive gear 46T (H).
17. Remove the 6 mm bushing (D).
18. Remove the buffer roll assembly (C) from inside the finisher.

Note: When remove the buffer roll assembly (C), do not touch the rubber surface.

Replacement notes:

- Make sure the flat spot on the end of the buffer roll assembly (C) is installed to the rear.

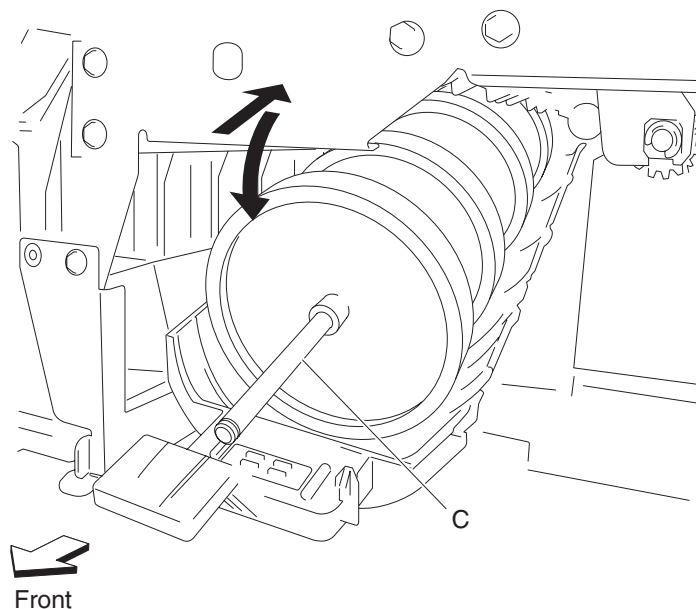

- When replacing the buffer roll assembly, do not touch the rubber surface.
- The tension of the belt (buffer/transport) (F) is automatically adjusted by the force of the spring attached to the belt tensioner bracket (E).
- Tighten the two screws in the order shown.

Buffer pinch guide assembly removal

1. Remove the finisher front door assembly. See **“Finisher front door assembly removal” on page 4-27.**
2. Remove the rear upper cover. See **“Rear upper cover removal” on page 4-24.**
3. Remove the stapler unit frame. See **“Stapler unit frame removal” on page 4-54.**
4. Lower the buffer pinch guide assembly (A) as far as it will go.
5. Move the buffer pinch guide assembly (A) to the right to remove the two bosses from the holes in the finisher.

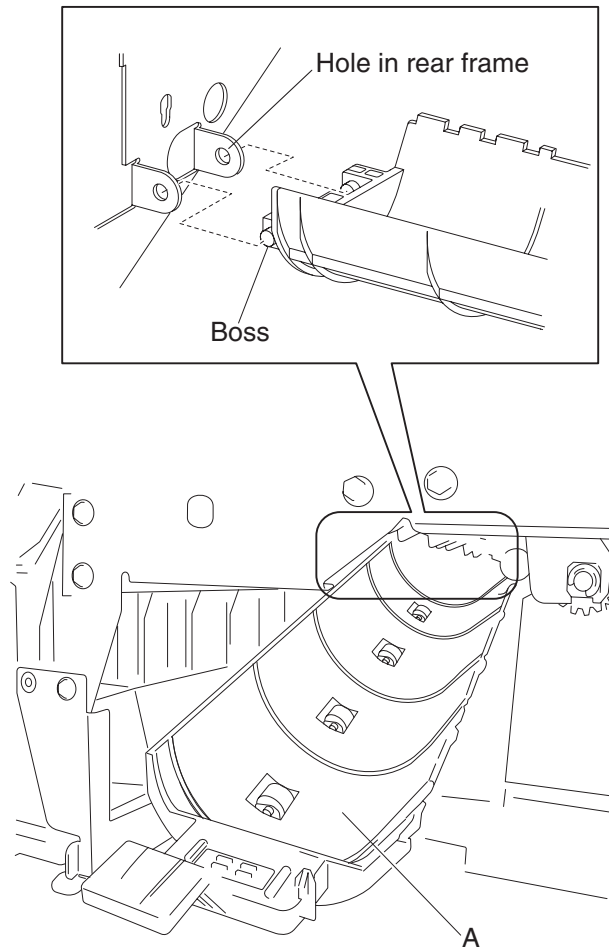

Media entrance pinch guide assembly removal

1. Open the finisher front door assembly.
2. Remove the rear upper cover. See **“Rear upper cover removal” on page 4-24.**
3. Remove the left lower cover. See **“Left lower cover removal” on page 4-28.**
4. Remove the left upper cover. See **“Left upper cover removal” on page 4-29.**
5. Remove the screw securing the cover (A) to the media entrance pinch guide assembly (B).
6. Remove the cover (A).
7. Disconnect the connector from the sensor (finisher media entrance) (C).
8. Release the harness from the clamps.
9. Remove the three screws securing the media entrance pinch guide assembly (B).

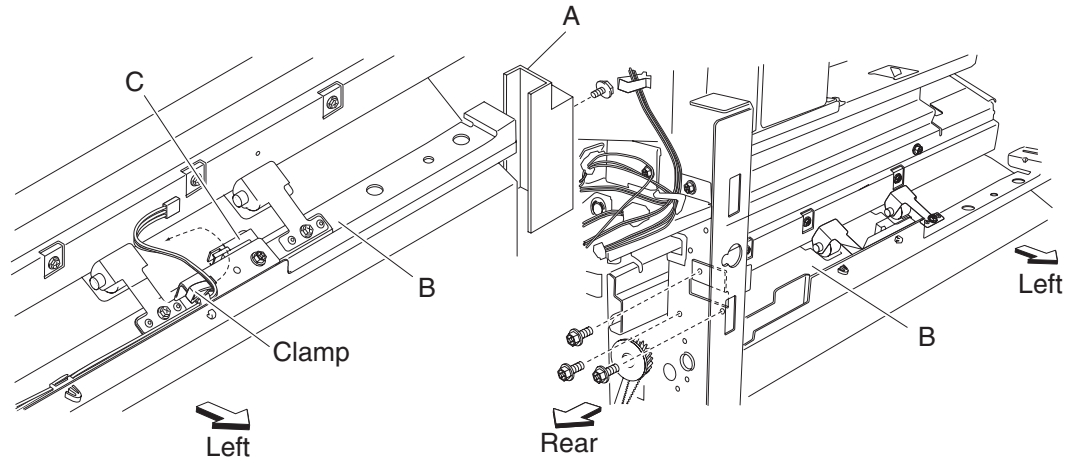

10. Remove the entrance pinch guide assembly (B) from the finisher.

Sensor (finisher media entrance) removal

1. Open the front door assembly.
2. Remove the rear upper cover. See **“Rear upper cover removal” on page 4-24.**
3. Remove the top cover. See **“Top cover removal” on page 4-19.**
4. Remove the left lower cover. See **“Left lower cover removal” on page 4-28.**
5. Remove the left upper cover. See **“Left upper cover removal” on page 4-29.**
6. Disconnect the connector from the sensor (finisher media entrance) (A).
7. Release the harness from the clamp.
8. Remove the screw securing the bracket (B) to the media entrance pinch guide assembly (C).

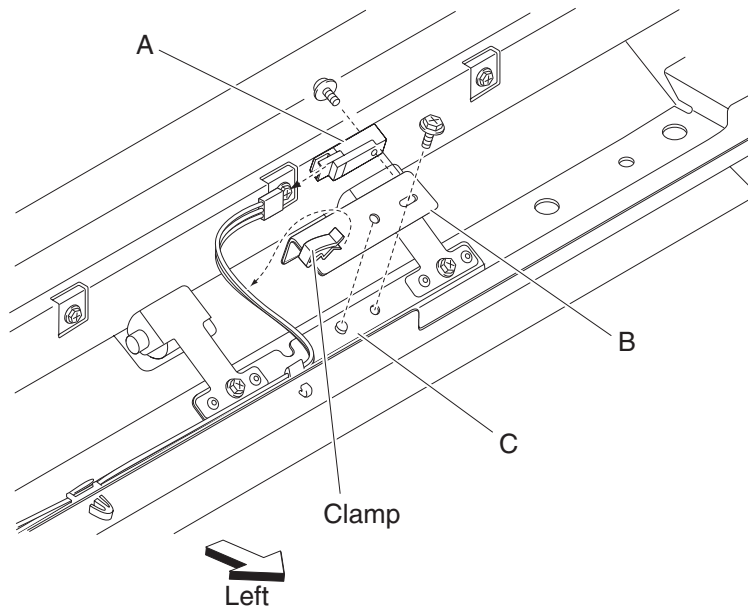

9. Release the hooks securing the sensor (finisher media entrance) (A) to the bracket (B).
10. Remove the sensor (finisher media entrance) (A).

Media entrance roll assembly removal

1. Remove the finisher front door assembly. See **“Finisher front door assembly removal”** on page 4-27.
2. Remove the rear upper cover. See **“Rear upper cover removal”** on page 4-24.
3. Remove the left upper cover. See **“Left upper cover removal”** on page 4-29.
4. Remove the punch waste box (A) from the finisher.
5. Remove the screw securing the cover (B) to the media entrance pinch guide assembly.
6. Remove the cover (B).
7. Lift the media entrance pinch guide assembly (C).
8. Loosen the two screws securing the belt tensioner bracket (D) to the finisher and move it upward in the direction of the arrow.
9. Remove the belt (entrance/paddle) (E) from the entrance drive pulley 20T (F).

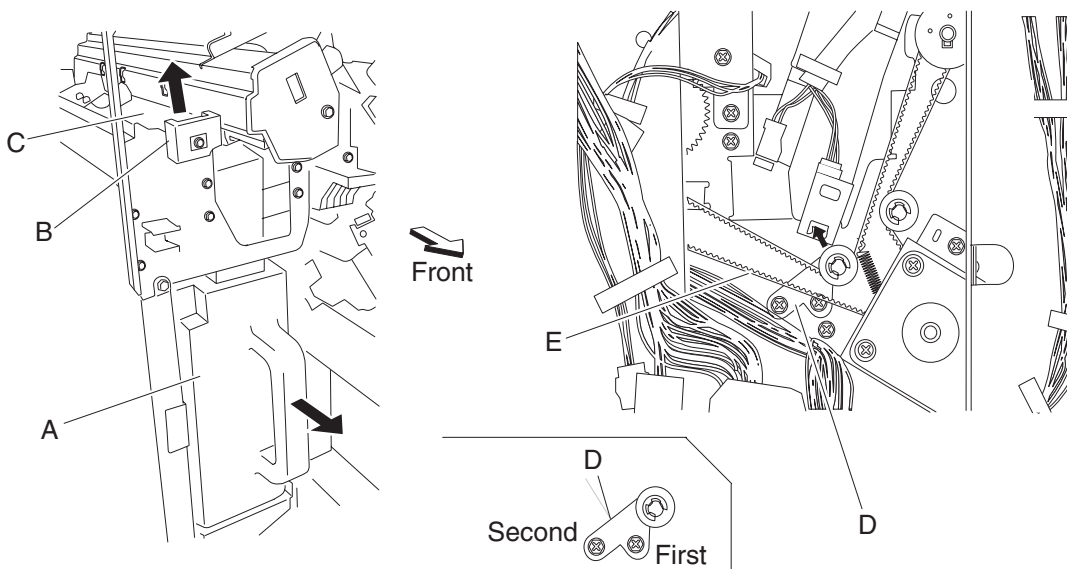

10. Release the hook securing the entrance drive gear 23T (G) to the media entrance roll assembly (H).
11. Remove the entrance drive gear 23T (G).
12. Remove the entrance drive pulley 20T (F).
13. Remove the bushing (I).
14. Remove the e-clip securing the media entrance roll assembly (H) to the front of the finisher.
15. Remove the bushing (J).

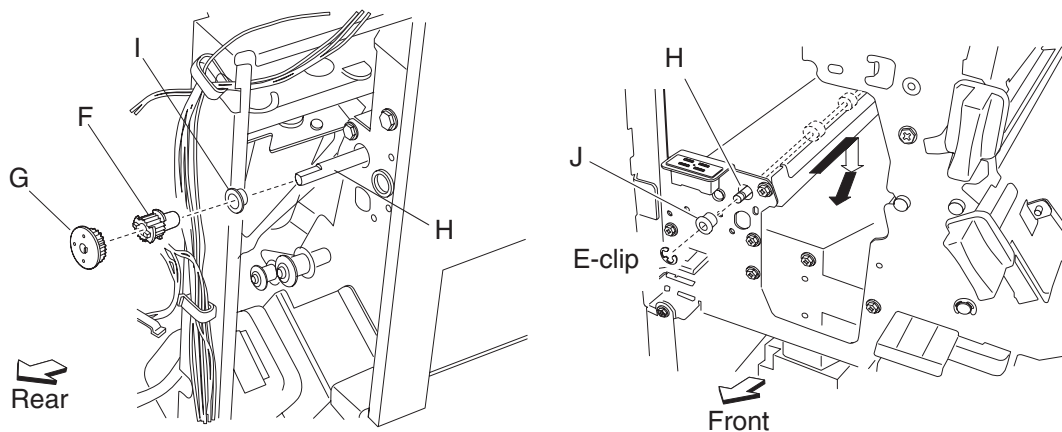

16. Move the media entrance roll assembly (H) toward the rear, downward, and then forward.
17. Remove the media entrance roll assembly (H) through the inside of the finisher.

Note: When removing the media entrance roll assembly (H), do not touch the rubber surface.

Replacement notes:

- Make sure the flat spot on the media entrance roll assembly (H) is installed to the rear.
- When replacing the media entrance roll assembly (H), do not touch the rubber surface.
- The tension of the belt (entrance/paddle) (E) is automatically adjusted to the force of the spring attached to the belt tensioner bracket (D).
- Tighten the two screws in the order shown.

Drive motor (entrance/paddle) and belt (entrance/paddle) removal

1. Remove the rear upper cover. See **“Rear upper cover removal” on page 4-24.**
2. Loosen the two screws securing the belt tensioner bracket (A) to the finisher and move upward, as shown.
3. Remove the belt (entrance/paddle) (B) from the drive motor (entrance/paddle) (C).
4. Disconnect the connector from the drive motor (entrance/paddle) (C).

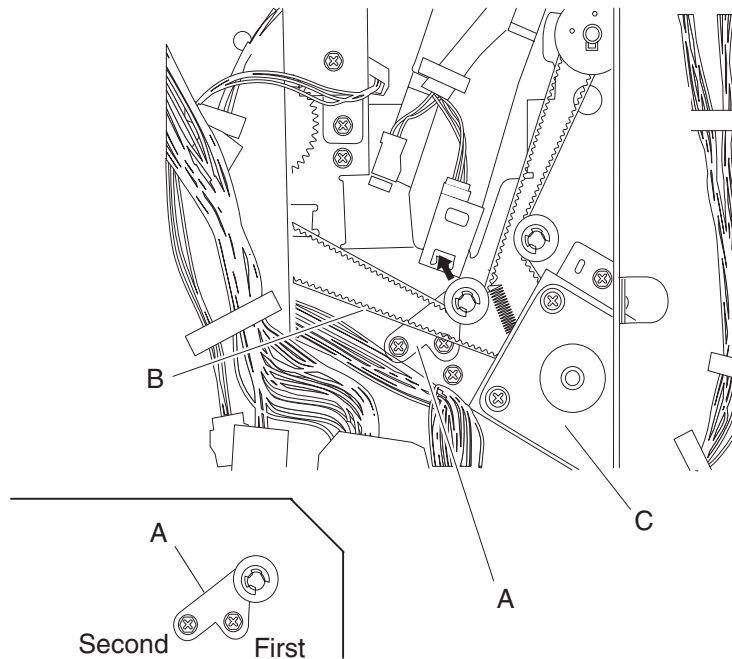

5. Remove the two screws securing the bracket (D) to the finisher.

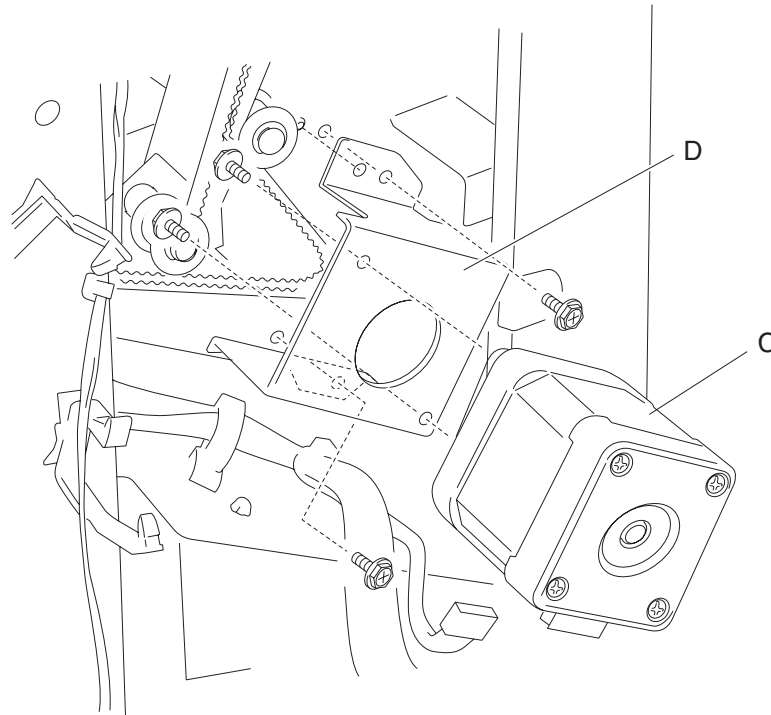

6. Remove the bracket (D).
7. Remove the two screws securing the bracket (D) to the drive motor (entrance/paddle) (C).
8. Remove the drive motor (entrance/paddle) (C).
9. Remove the belt (entrance/paddle) (B).

Replacement notes:

- The tension of the belt (entrance/paddle) (B) is automatically adjusted by the force of the spring attached to the belt tensioner bracket (A).
- Tighten the two screws in the order shown.

Media diverter gate solenoid removal

1. Open the finisher front door assembly.
2. Remove the rear upper cover. See **“Rear upper cover removal” on page 4-24.**
3. Disconnect the connector from the media diverter gate solenoid (A).
4. Release the harness from the clamp.
5. Remove the two screws securing the bracket (B) to the finisher.
Note: The bracket should not be removed from the finisher, it should be gently moved to provide better access to the media diverter gate solenoid mounting screws.
6. Remove the two screws securing the media diverter gate solenoid to the finisher.
7. Remove the media diverter gate solenoid.
Note: The link (C) may remain inserted into the finisher.

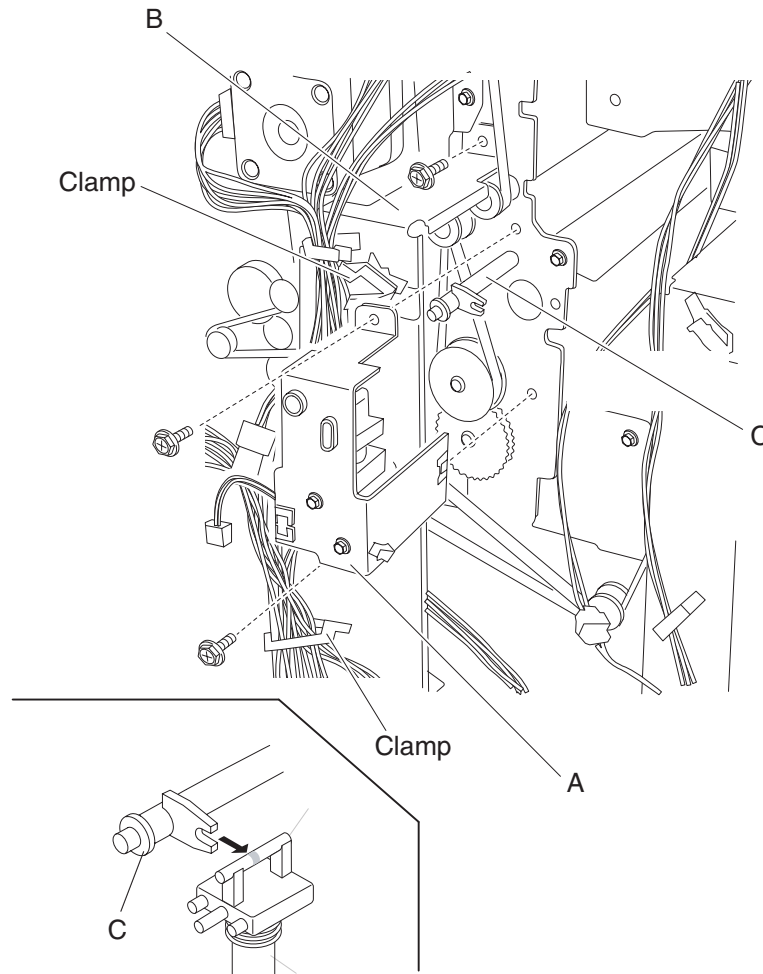

8. Remove the link.
Note: When the link is removed, the media diverter gate may become detached. See **“Media diverter gate removal” on page 4-91.**

Buffer diverter gate solenoid removal

1. Open the finisher front door assembly.
2. Remove the rear upper cover. See **“Upper media bin front cover removal” on page 4-25.**
3. Disconnect the connector from the buffer diverter gate solenoid (A).
4. Release the harness from the clamp.
5. Remove the two screws securing the buffer diverter gate solenoid to the finisher.
6. Remove the buffer diverter gate solenoid.

Note: The link (B) may remain inserted into the finisher.

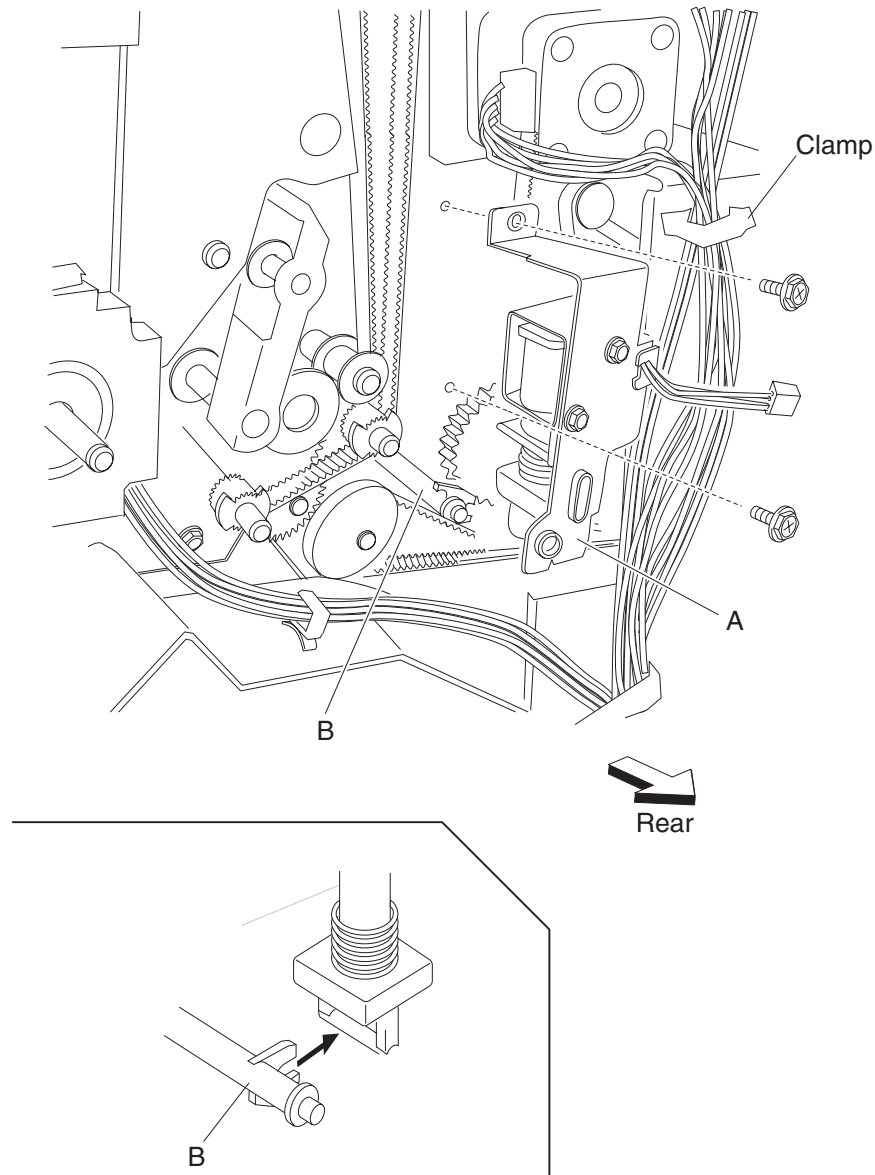

7. Remove the link.

Note: When the link is removed, the buffer diverter gate may become detached. See **“Buffer diverter gate removal” on page 4-92.**

Sensor (upper media exit) removal

1. Open the finisher front door assembly.
2. Remove the rear upper cover. See **“Rear upper cover removal” on page 4-24.**
3. Remove the top cover. See **“Top cover removal” on page 4-19.**
4. Disconnect the connector from the sensor (upper media exit) (A).

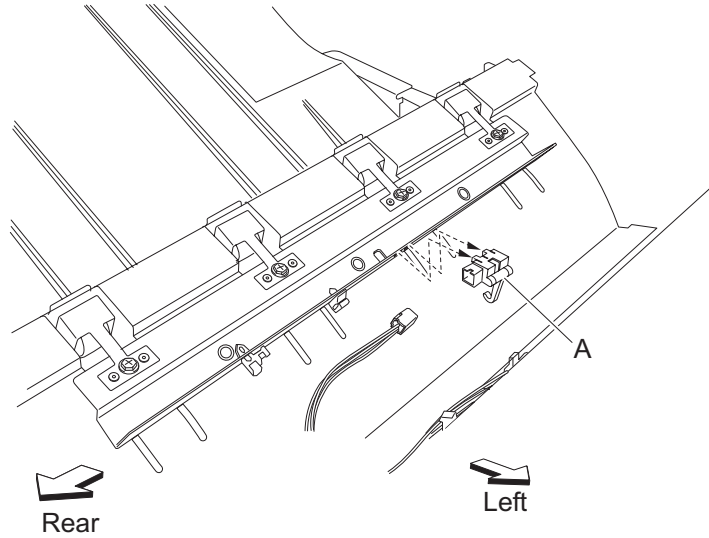

5. Release the hooks securing the sensor (upper media exit) (A) to the finisher.
6. Remove the sensor (upper media exit) (A).

Upper media exit pinch roll assembly removal

1. Open the finisher front door assembly.
2. Remove the rear upper cover. See **“Rear upper cover removal” on page 4-24.**
3. Remove the top cover. See **“Top cover removal” on page 4-19.**
4. Remove the four screws securing the four upper media exit pinch roll assemblies (A) to the finisher.

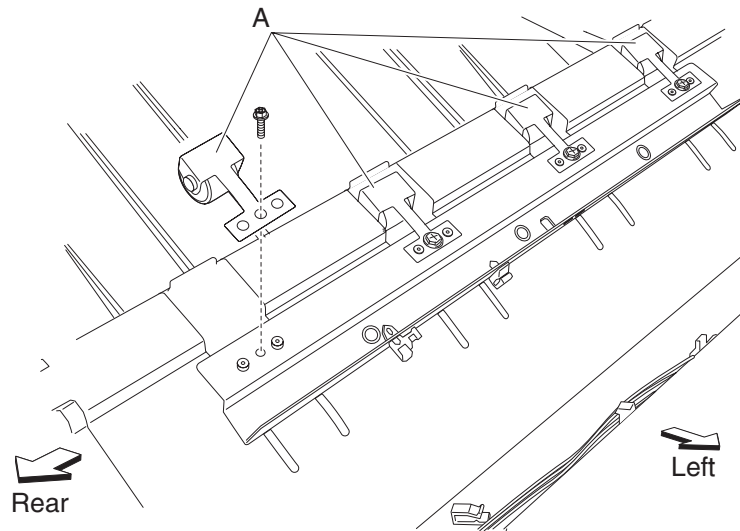

5. Remove the four upper media exit pinch roll assembly (A).

Upper media exit roll assembly removal

1. Open the finisher front door assembly.
2. Remove the rear upper cover. See **“Rear upper cover removal” on page 4-24.**
3. Remove the top cover. See **“Top cover removal” on page 4-19.**
4. Remove the drive motor (exit). See **“Drive motor (exit) assembly and belt (exit) removal” on page 4-113.**
5. Disconnect the connector from the sensor (upper media exit) (A).

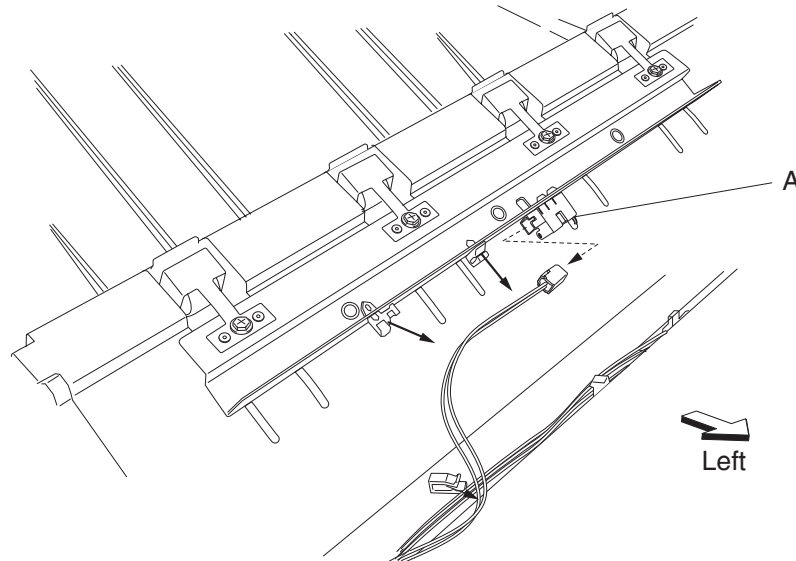

6. Release the harness from the clamps.
7. Remove the two front and two rear screws securing the upper exit guide assembly (B).
8. Remove the upper exit guide assembly.
9. Remove the two front screws and the two rear screws securing the bracket (C) to the finisher.

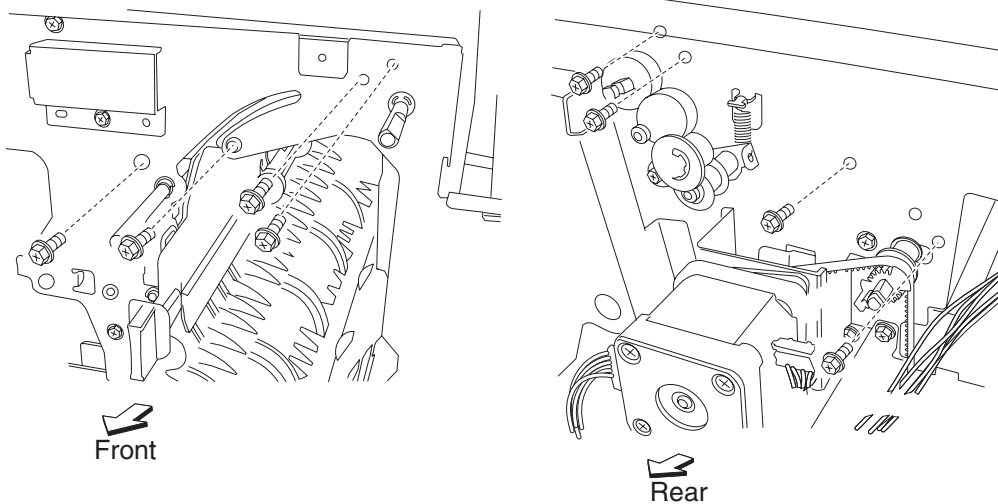

10. Remove the bracket (C).

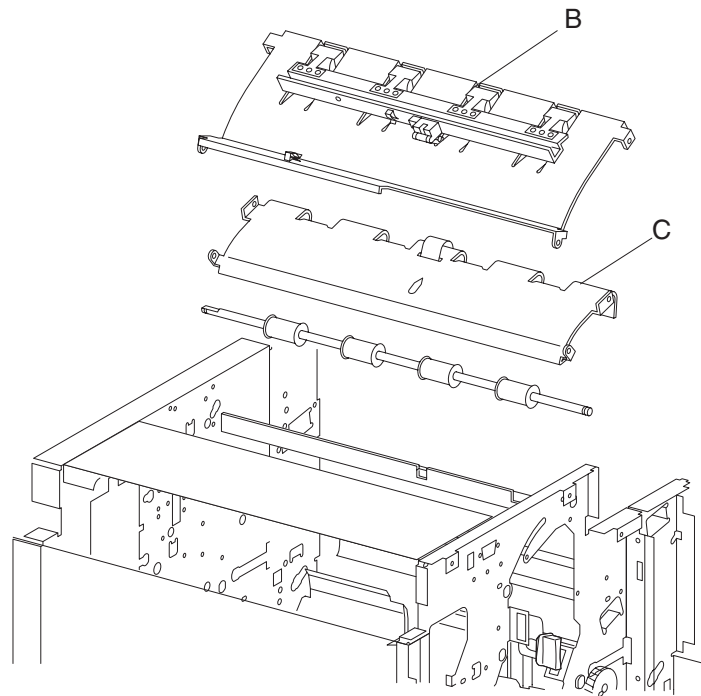

11. Release the hook from the upper media exit roll drive gear 20T(D).
 12. Remove the upper media exit roll drive gear 20T.
 13. Remove the 6 mm bushing.
 14. Remove the e-clip with a prying tool securing the upper media exit roll assembly (F) to the front of the finisher.
 15. Remove the 6 mm bushing (E).
 16. Move the upper media exit roll assembly frontward and outward in the direction of the arrow.

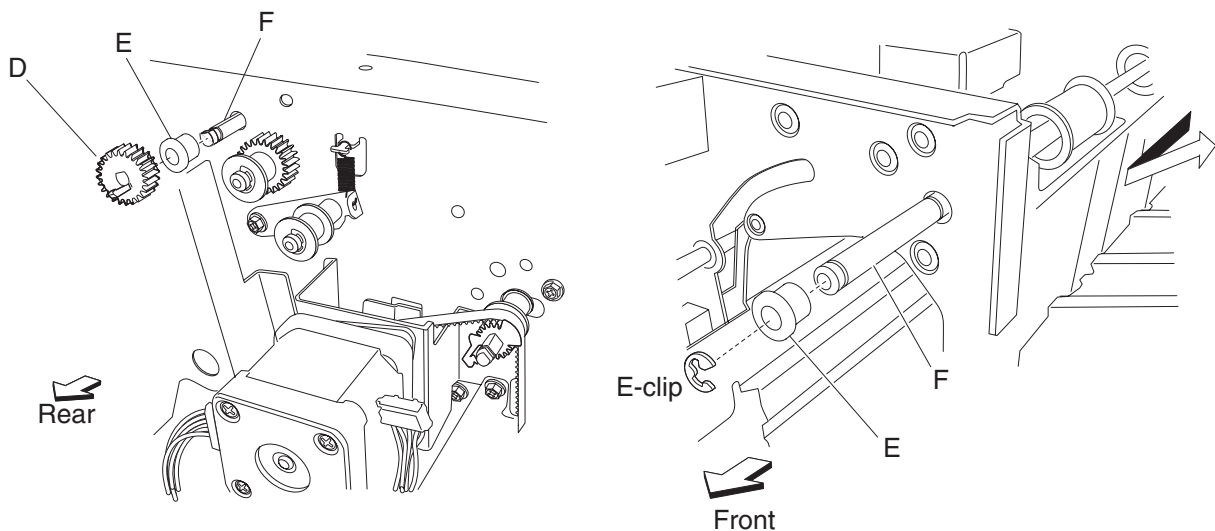

17. Remove the upper media exit roll assembly (F).
Note: When removing the upper media exit roll assembly (F), do not touch the rubber surface.

Replacement notes:

- Make sure the flat spot of the upper media exit roll assembly (F) is installed to the rear.
- When replacing the upper media exit roll assembly (F), do not touch the rubber surface.

Sensor (upper media bin full) removal

1. Open the finisher front door assembly.
2. Remove the screw securing the bracket (A) to the upper media bin vertical cover (B).
3. Move the bracket frontward and downward to gain access to the harness and connector.
4. Release the harness from the clamp.
5. Move the bracket (B) frontward again, and remove the screw securing the sensor (upper media bin full) (C) to the bracket.

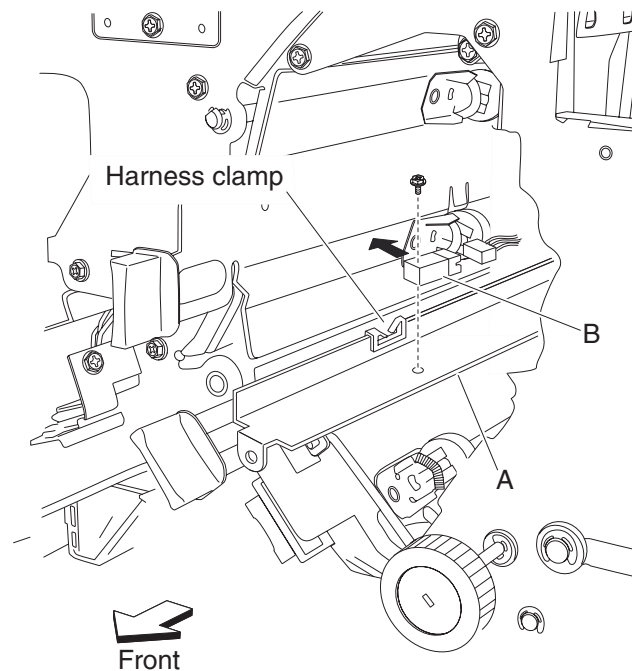
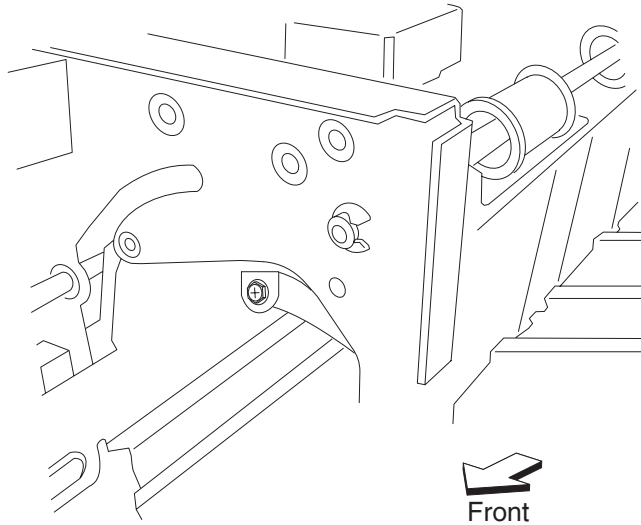

6. Remove the sensor (upper media bin full) (C).
7. Disconnect the connector from the sensor (upper media bin full) (C).

Upper pinch guide assembly removal

1. Open the finisher front door assembly.
2. Remove the rear upper cover. See **“Rear upper cover removal”** on page 4-24.
3. Remove the drive motor (buffer/transport). See **“Drive motor (buffer/transport) and belt (buffer/transport) removal”** on page 4-115.
4. Remove the three screws securing the hinge of the upper pinch guide assembly (A) on the rear of the finisher.
5. Move the upper pinch guide assembly hinge from the rear of the finisher.
6. Remove the upper pinch guide assembly (A) from inside of the finisher in the direction of the arrow.

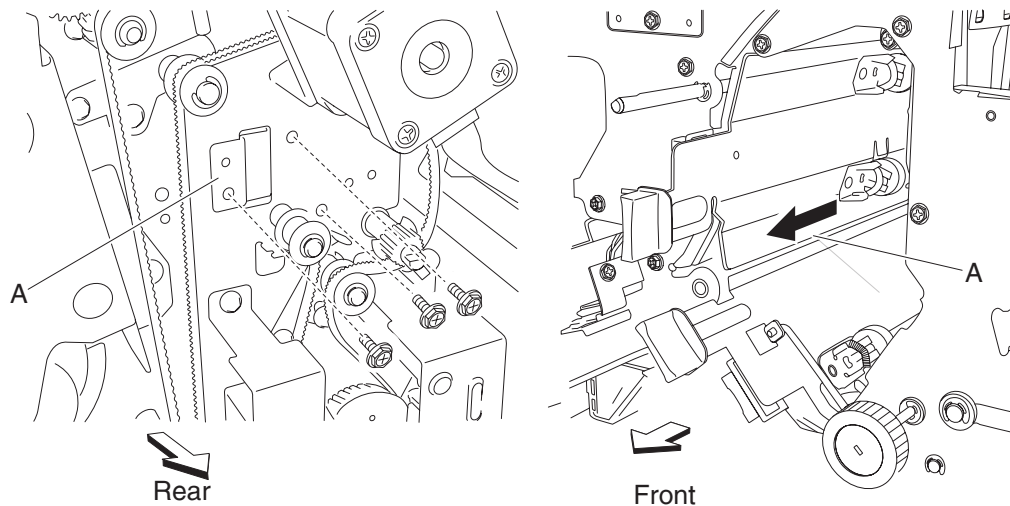

Sensor (diverter gate) removal

1. Open the finisher front door assembly.
2. Remove the rear upper cover. See **“Rear upper cover removal” on page 4-24.**
3. Remove the top cover. See **“Top cover removal” on page 4-19.**
4. Remove the left lower cover. See **“Left lower cover removal” on page 4-28.**
5. Remove the left upper cover. See **“Left upper cover removal” on page 4-29.**
6. Remove the punch carriage assembly. See **“Punch carriage assembly removal” on page 4-41.**
7. Remove the two screws securing the bracket (A) to the finisher.
8. Remove the bracket (A).
9. Disconnect the connector from the sensor (diverter gate) (B).
10. Remove the screw securing the sensor (diverter gate) (B) to the bracket (A).

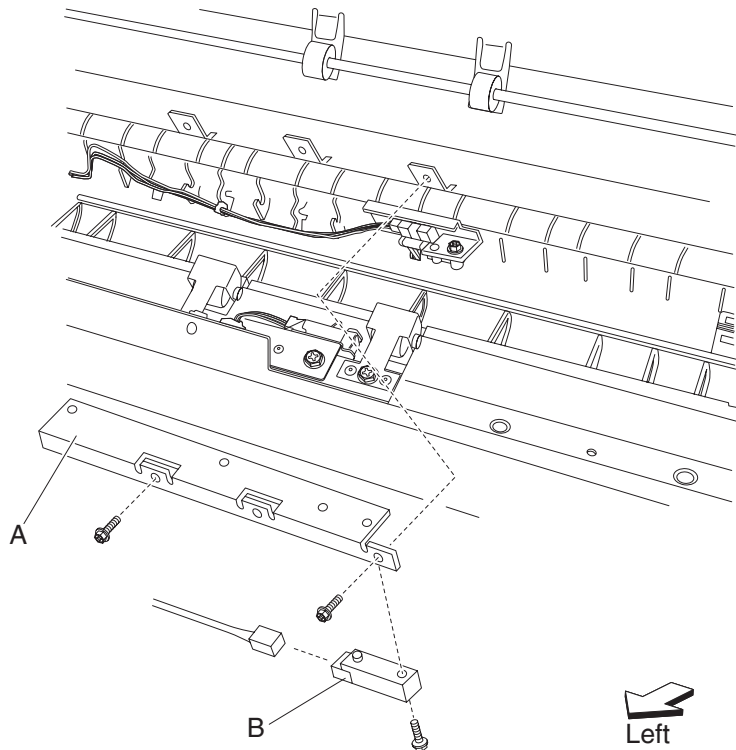

11. Remove the sensor (diverter gate) (B).

Upper media transport roll assembly removal

1. Open the finisher front door assembly.
2. Remove the rear upper cover. See **“Rear upper cover removal”** on page 4-24.
3. Remove the top cover. See **“Top cover removal”** on page 4-19.
4. Remove the left lower cover. See **“Left lower cover removal”** on page 4-28.
5. Remove the left upper cover. See **“Left upper cover removal”** on page 4-29.
6. Remove the punch carriage assembly. See **“Punch carriage assembly removal”** on page 4-41.
7. Open the upper pinch guide assembly (A) toward the right.
8. Remove the two screws securing the bracket (B) on the rear of the finisher.

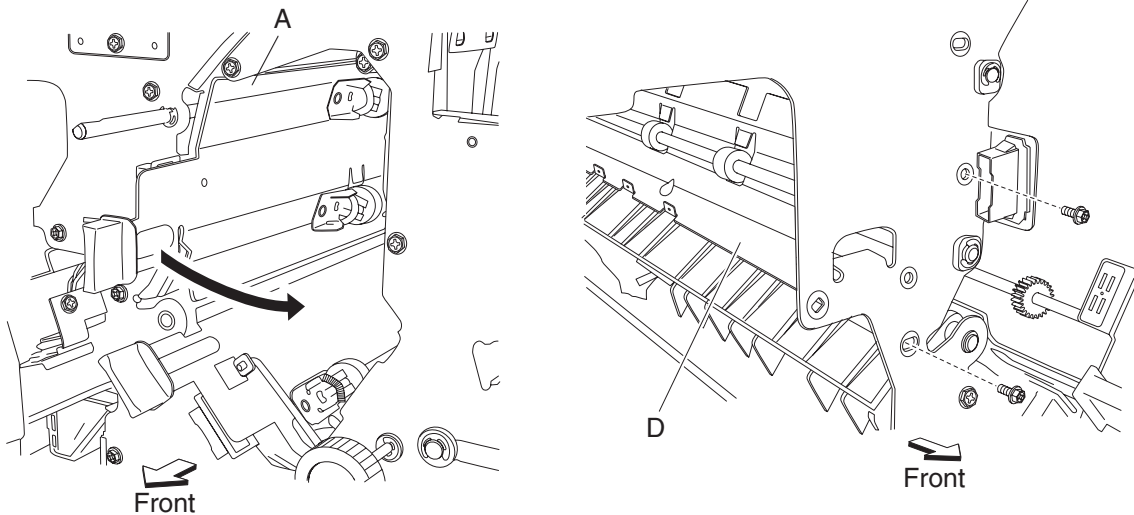

9. Move the bracket (B) slightly toward the exit side of the finisher.
Note: It is not necessary to remove the bracket from the finisher; it should only be slightly moved to provide better access to the two upper media transport roll assembly (C) for removal.

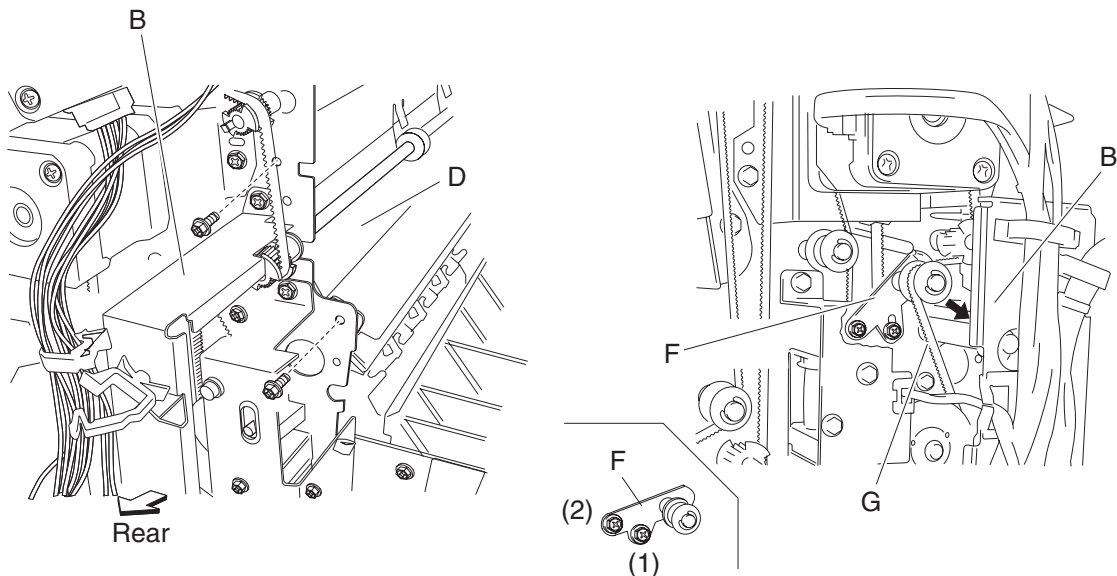

10. Remove the two screws securing the bracket (D).
Note: It is not necessary to remove the bracket from the finisher; it should only be slightly moved to provide better access to the two upper media transport roll drive pulley 20T(E).
11. Loosen the two screws securing the belt tensioner bracket (F) to the finisher, and move it downward as shown.
12. Remove the belt (buffer/transport) (G) from the two upper media transport roll drive pulley 20T (E).
13. Release the hook securing the appropriate upper media transport roll drive pulley 20T (E) to the appropriate upper media transport roll assembly (C).
14. Remove the appropriate upper media transport roll drive pulley 20T (E).
15. Remove the appropriate bushing (H).
16. With a prying tool, remove the e-clip securing the appropriate upper media transport roll assembly (C) to the front of the finisher.

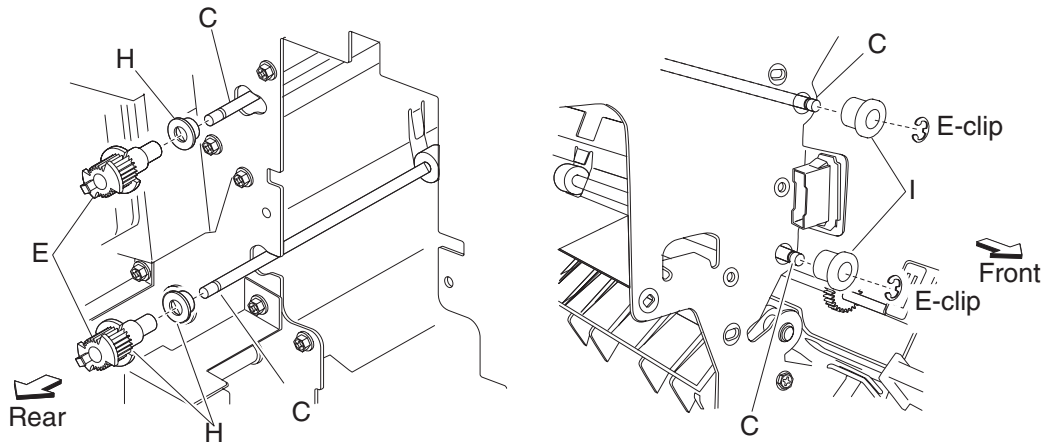

17. Remove the appropriate 6 mm bushing (I).
18. Move the appropriate upper media transport roll assembly (C) toward the front and outward.
19. Remove the appropriate upper media transport roll assembly (C).
Note: When removing the upper media transport roll assembly (C), do not touch the rubber surface.

Replacement notes

- Note:** Make sure the flat spot on the upper media transport roll assembly (C) is installed to the rear.
- Note:** When replacing the upper media transport roll assembly (C), do not touch the rubber surface.
- Note:** The tension of the belt (buffer/transport) (G) is automatically adjusted by the force of the spring attached to the belt tensioner bracket (F).
- Note:** Tighten the two screws in the order shown.

Drive motor (exit) assembly and belt (exit) removal

1. Remove the rear upper cover. See **“Rear upper cover removal”** on page 4-24.
2. Loosen the two screws securing the belt tensioner bracket (A) to the finisher, and move it down as shown.
3. Remove the belt (exit) (B) from the drive motor (exit) assembly (C).
4. Disconnect the connector from the drive motor (exit) assembly.

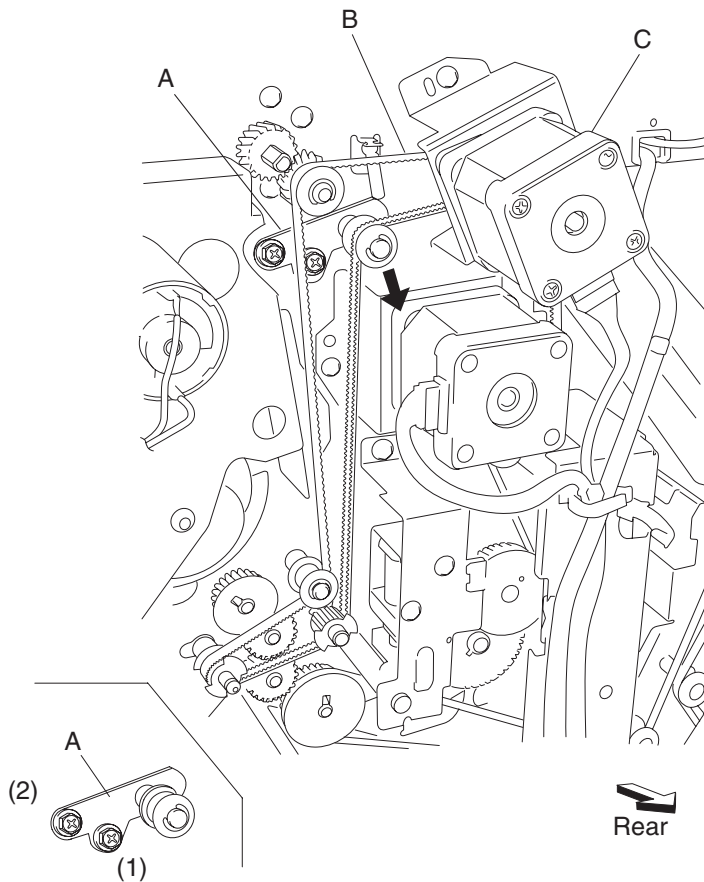

5. Remove the two screws securing the bracket (D) to the finisher.
6. Remove the bracket (D).
7. Remove the two screws securing the drive motor (exit) assembly to the bracket (D).

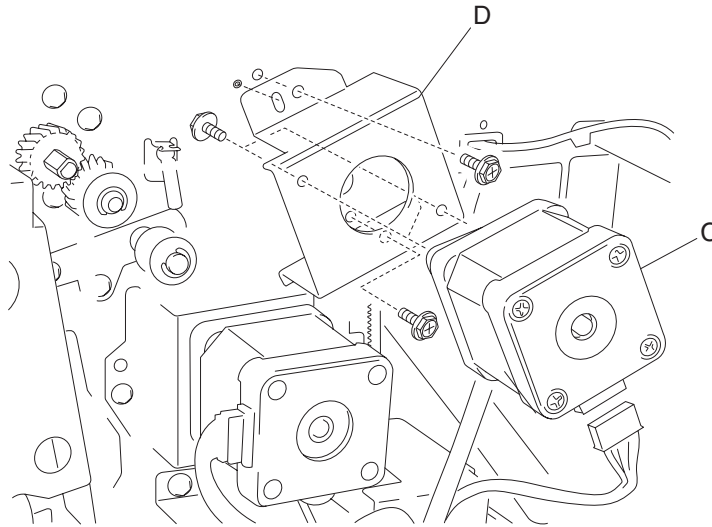

8. Remove the drive motor (exit) assembly (C).

Replacement notes

Note: The tension of the belt (exit) (B) is automatically adjusted by the force of the spring attached to the belt tensioner bracket (A).

Note: Tighten the two screws in the order shown.

Drive motor (buffer/transport) and belt (buffer/transport) removal

1. Remove the rear upper cover. See **“Rear upper cover removal”** on page 4-24.
2. Remove the two screws securing the bracket (A) on the rear of the finisher.
3. Move the bracket slightly.
Note: It is not necessary to remove the bracket from the finisher. It should only be slightly moved to provide better access to the drive motor (buffer/transport) (B) for removal.
4. Loosen the two screws securing the belt tensioner bracket (C) to the finisher, and move it down as shown.
5. Remove the belt (buffer/transport) (D) from the drive motor (buffer/transport).

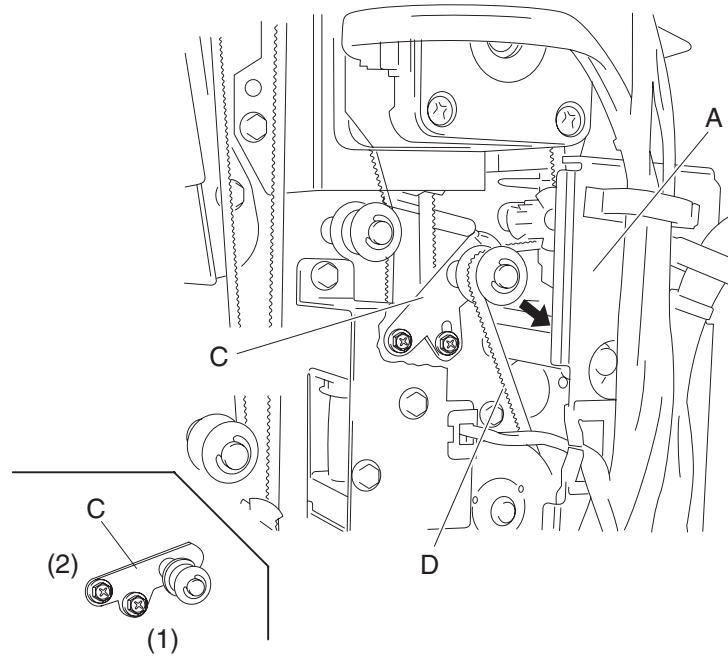

6. Disconnect the connector from the drive motor (buffer/transport).
7. Remove the two screws securing the bracket (E) to the finisher.
8. Remove the bracket.
9. Remove the two screws securing the drive motor (buffer/transport) to the bracket.
10. Remove the drive motor (buffer/transport).
11. Remove the belt (buffer/transport) (D).

Replacement notes

Note: The tension of the belt (buffer/transport) (D) is automatically adjusted by the force of the spring attached to the belt tensioner bracket (C).

Note: Tighten the two screws in the order shown.

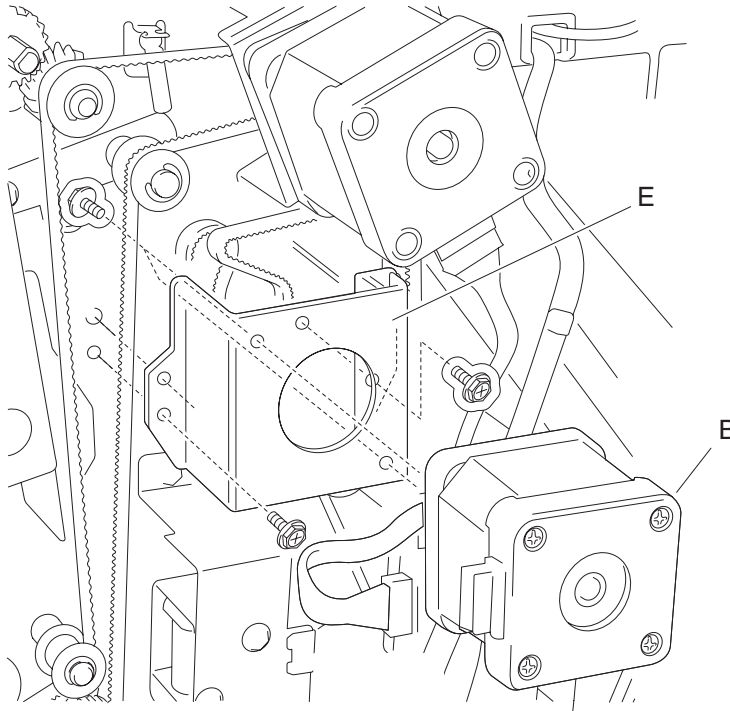

Bridge unit interface card assembly removal

1. Remove the rear upper cover. See **“Rear upper cover removal”** on page 4-24.
2. Disconnect all the connectors from the bridge unit interface card assembly (A).
3. Remove the two screws securing the bridge unit interface card assembly (A) to the finisher.

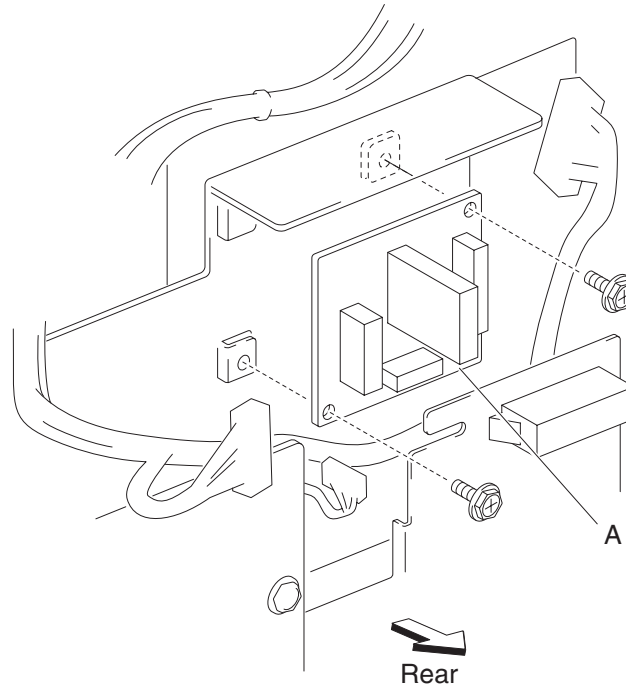

4. Remove the bridge unit interface card assembly (A).

Finisher controller card assembly removal

1. Remove the rear upper cover. See **“Rear upper cover removal”** on page 4-24.
2. Remove the rear lower cover. See **“Rear lower cover removal”** on page 4-23.
3. Loosen the four screws securing the plate (A) to the finisher.
4. Move the plate (A) to the right and outward.

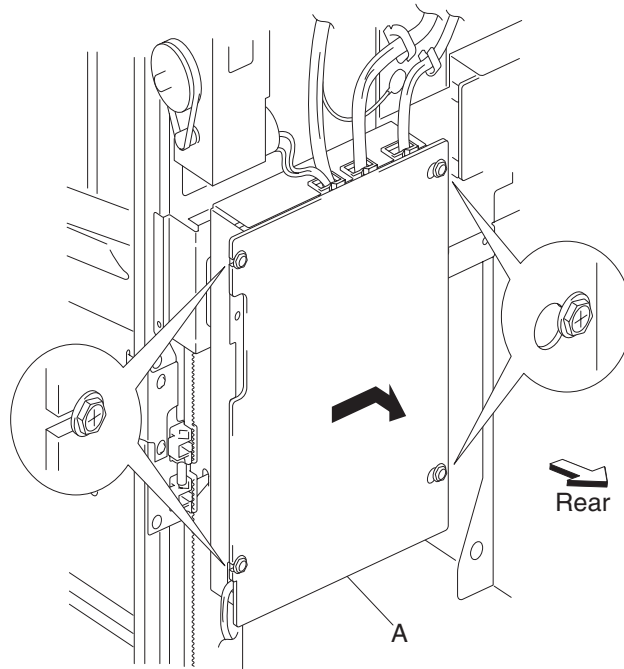

5. Remove the plate (A).
6. Disconnect the connectors from the finisher controller card assembly (B).

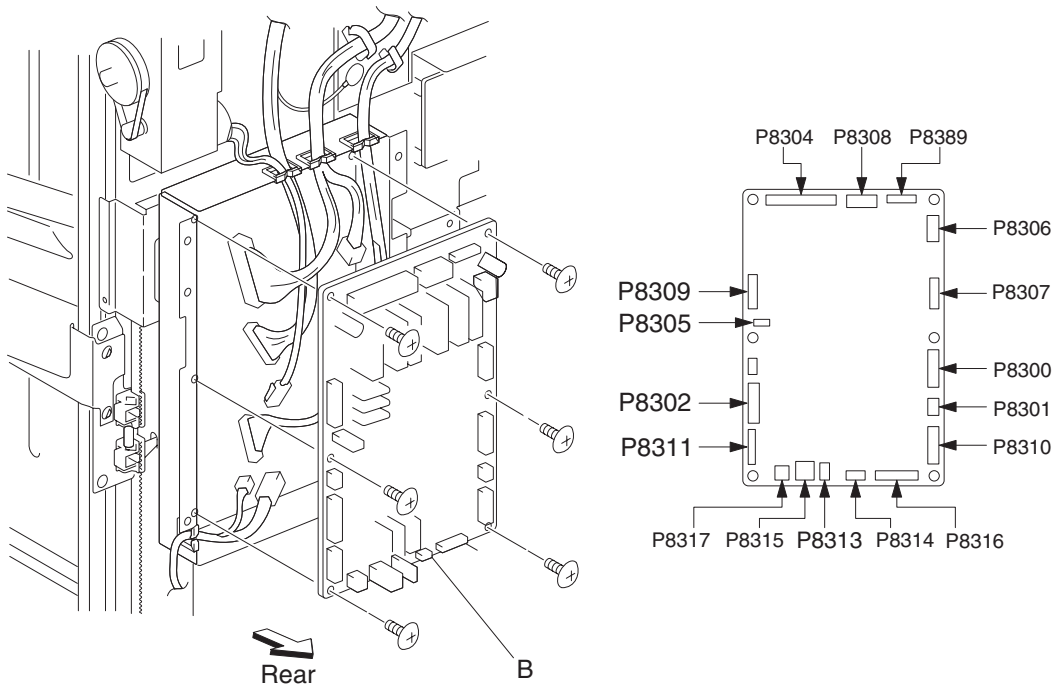

7. Remove the six screws securing the finisher controller card assembly (B).
8. Remove the finisher controller card assembly (B).

Finisher low voltage power supply (LVPS) removal

1. Remove the right lower cover. See **“Rear lower cover removal”** on page 4-23.
2. Disconnect all the connectors from the finisher LVPS (A).
3. Remove the two screws securing the finisher LVPS (A) to the finisher.

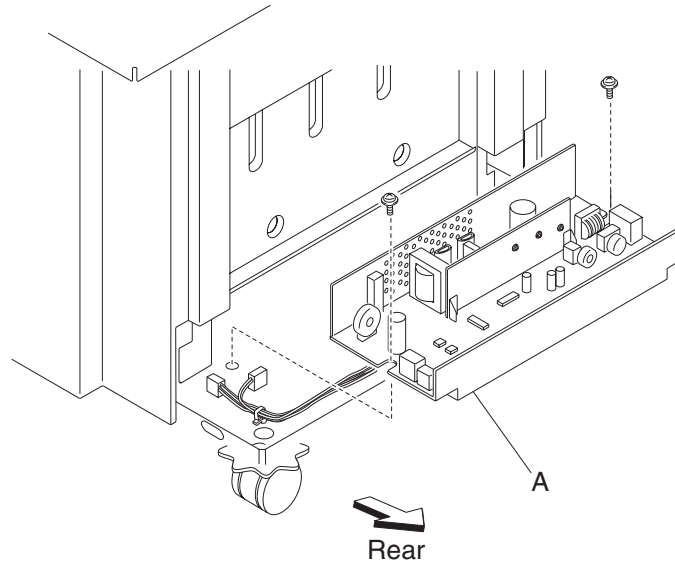

4. Remove the finisher LVPS (A).

4024-XXX

5. Component locations

Locations

Bridge unit assembly

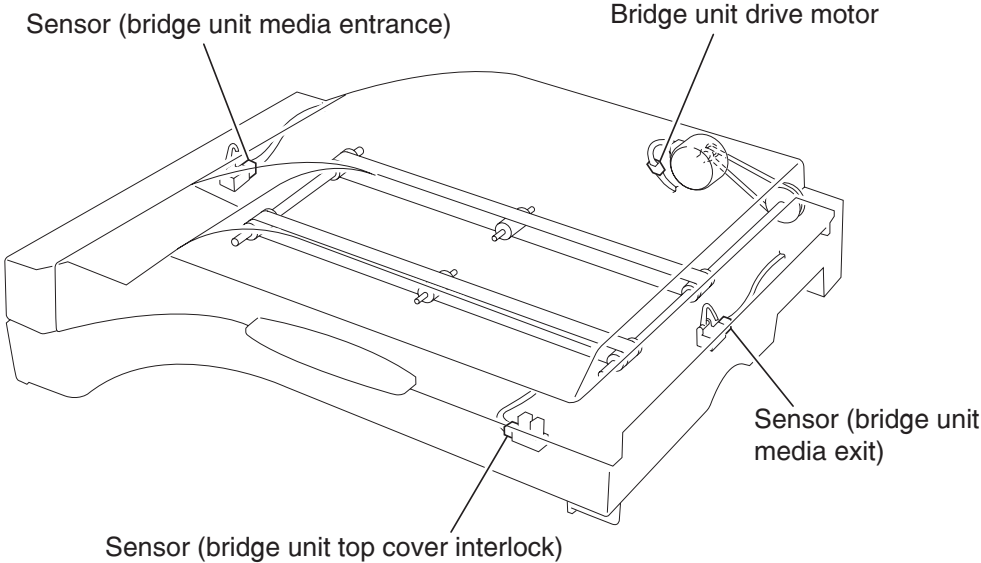

Stacker lift and stapler

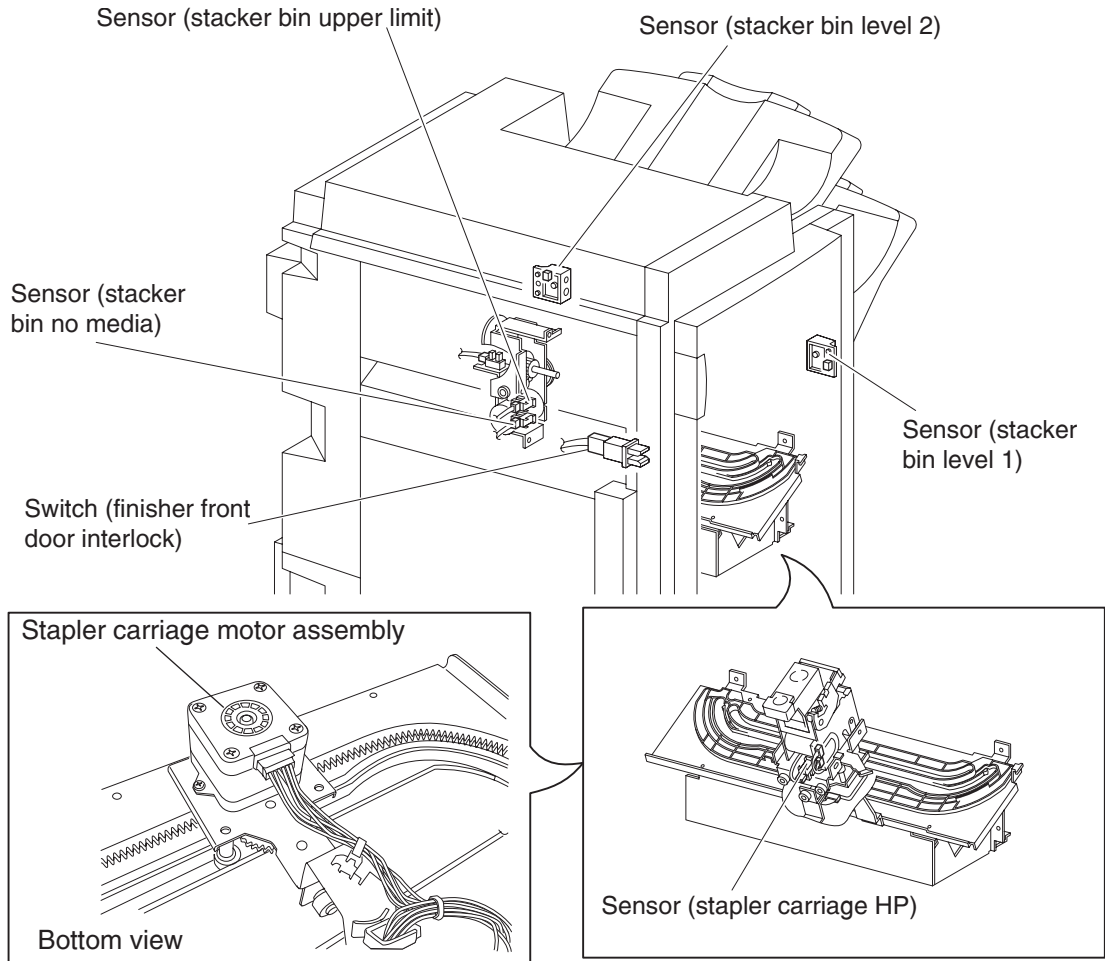

Punch unit

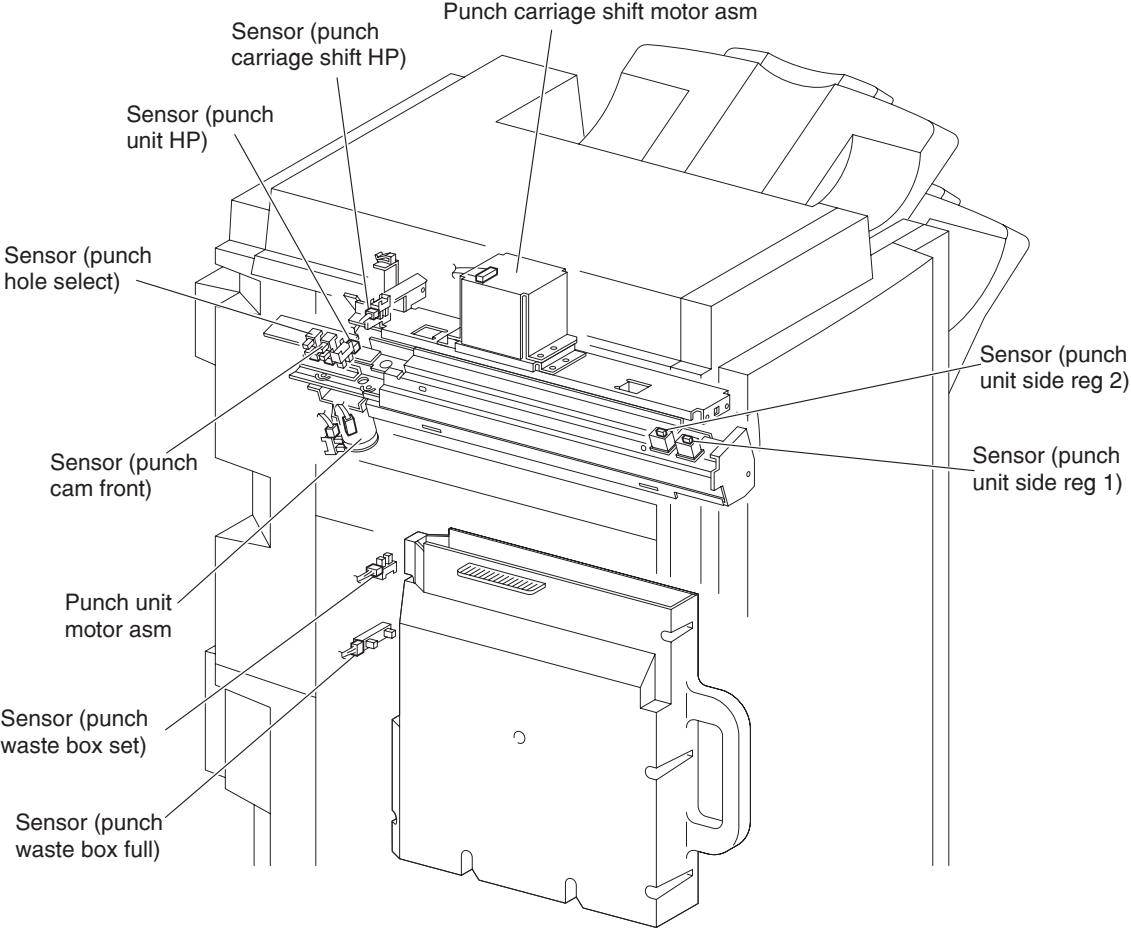

Diverter and media eject

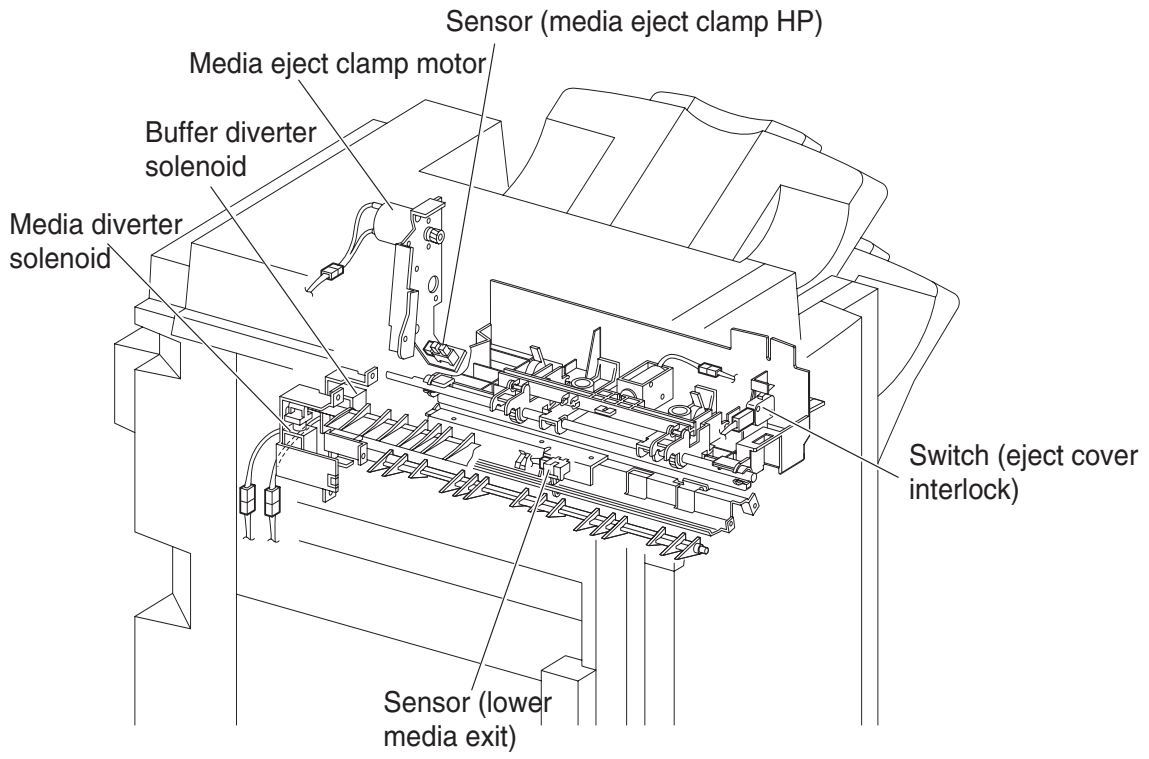

Media eject and media compiler

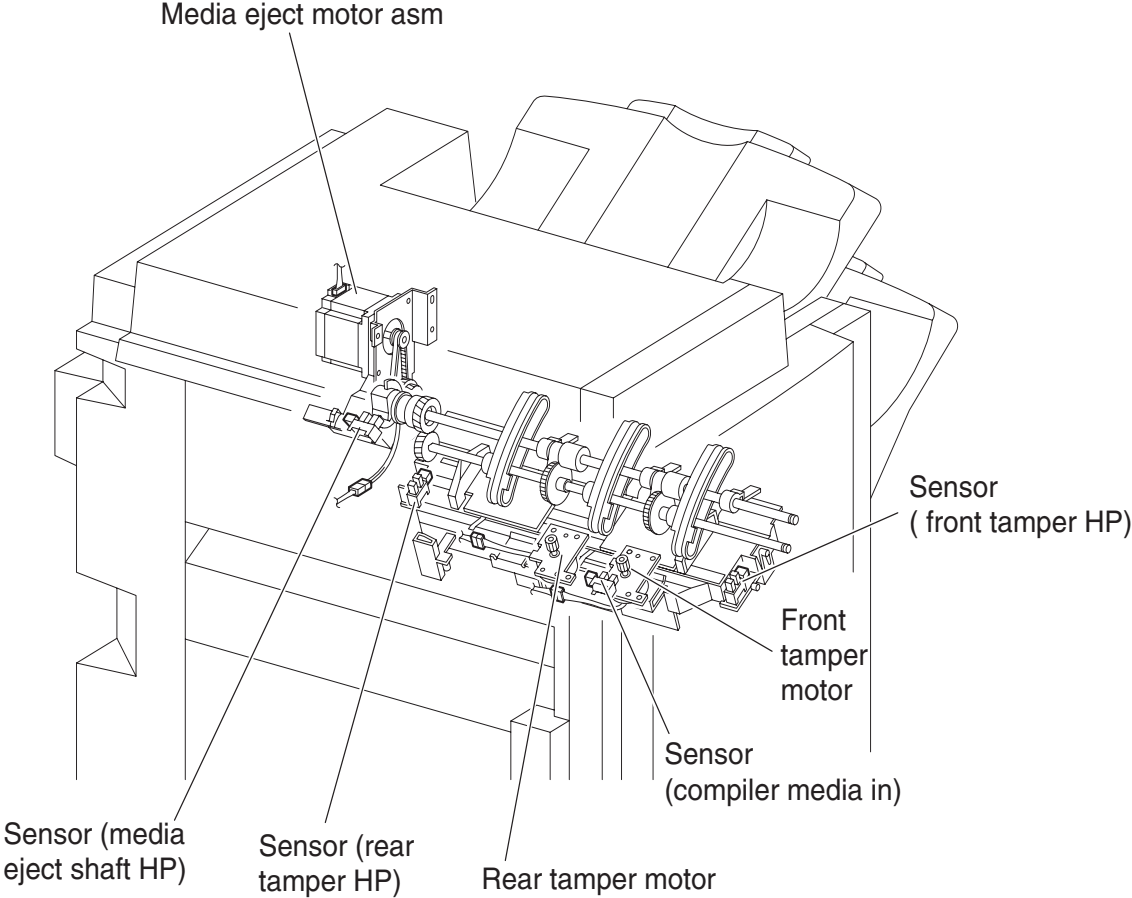

Buffer, upper exit, lower exit, and drive motors

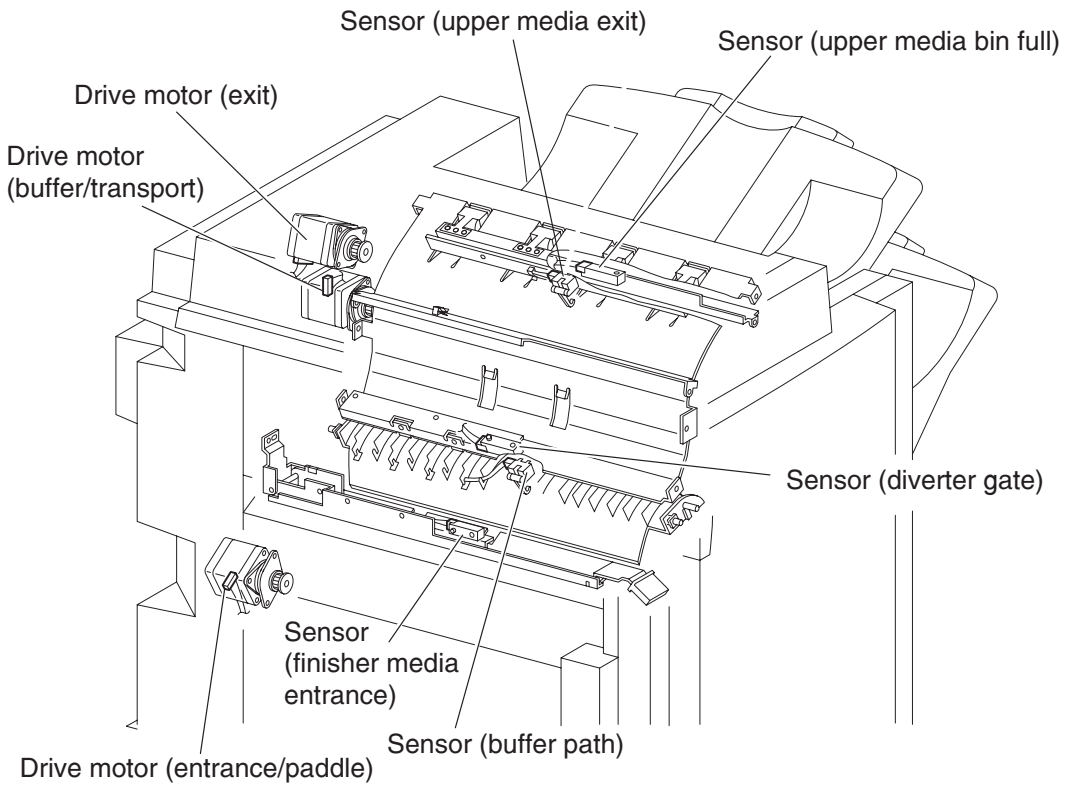

Finisher controller card assembly

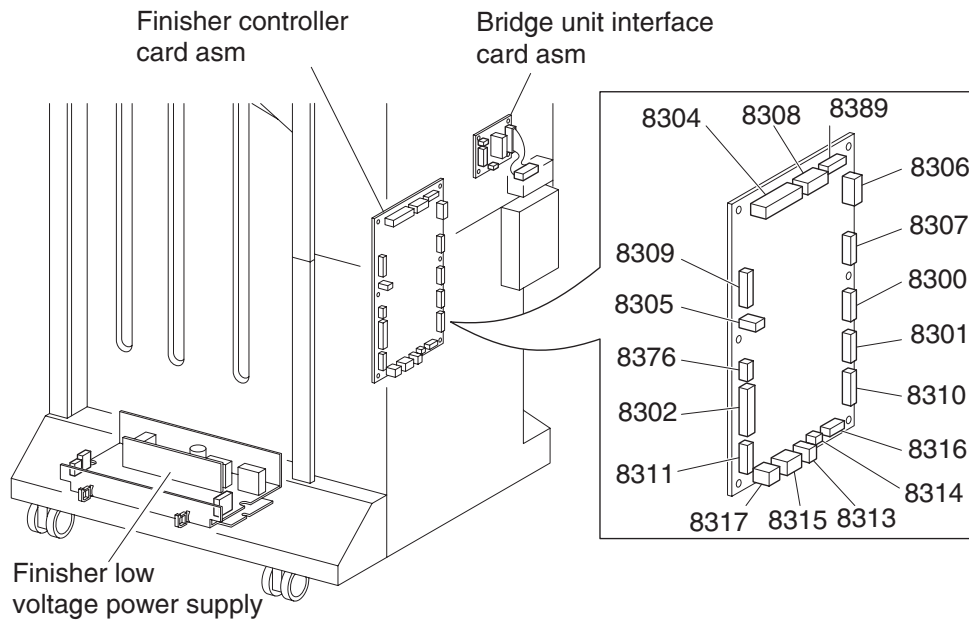

Cabling

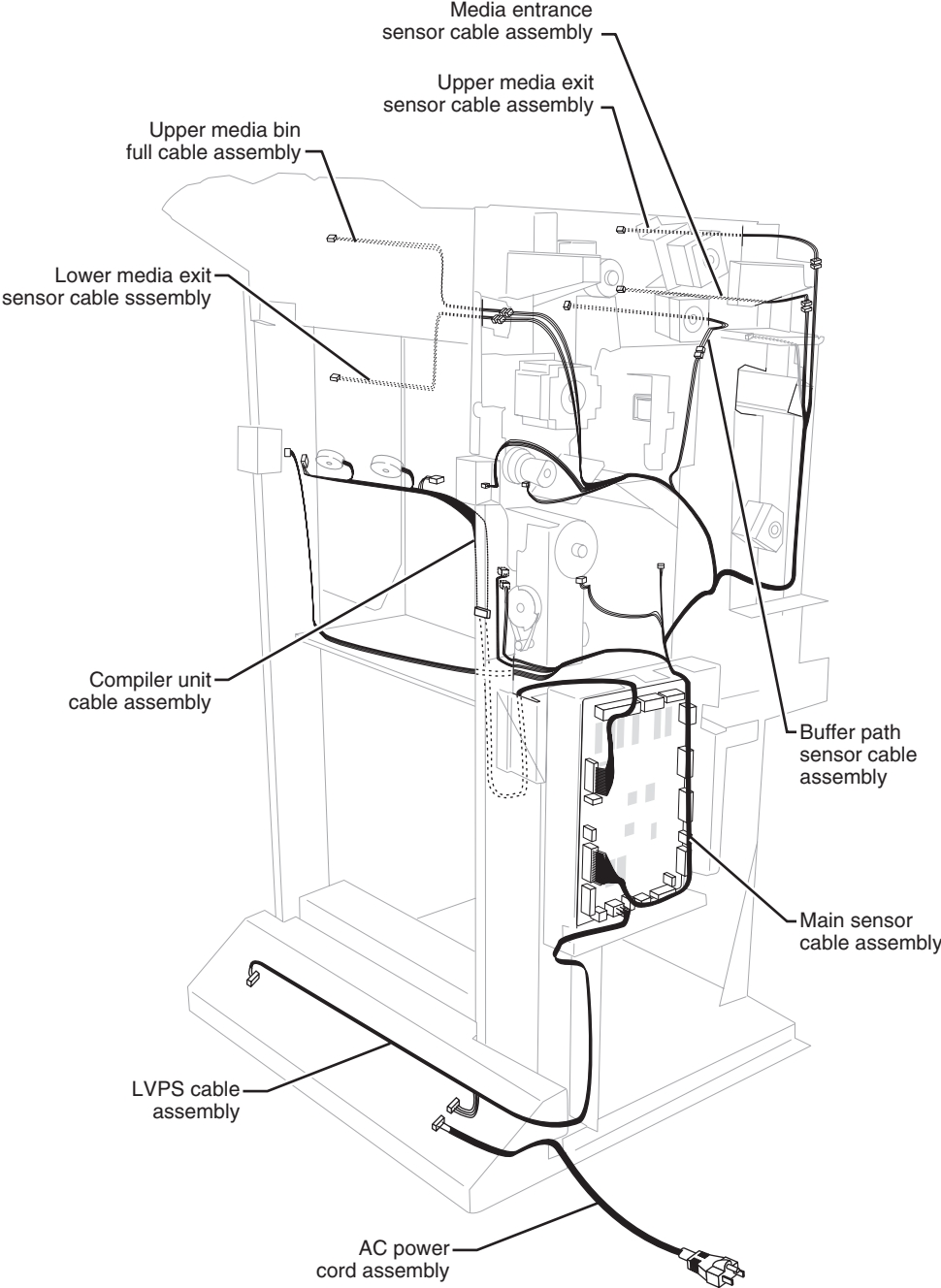

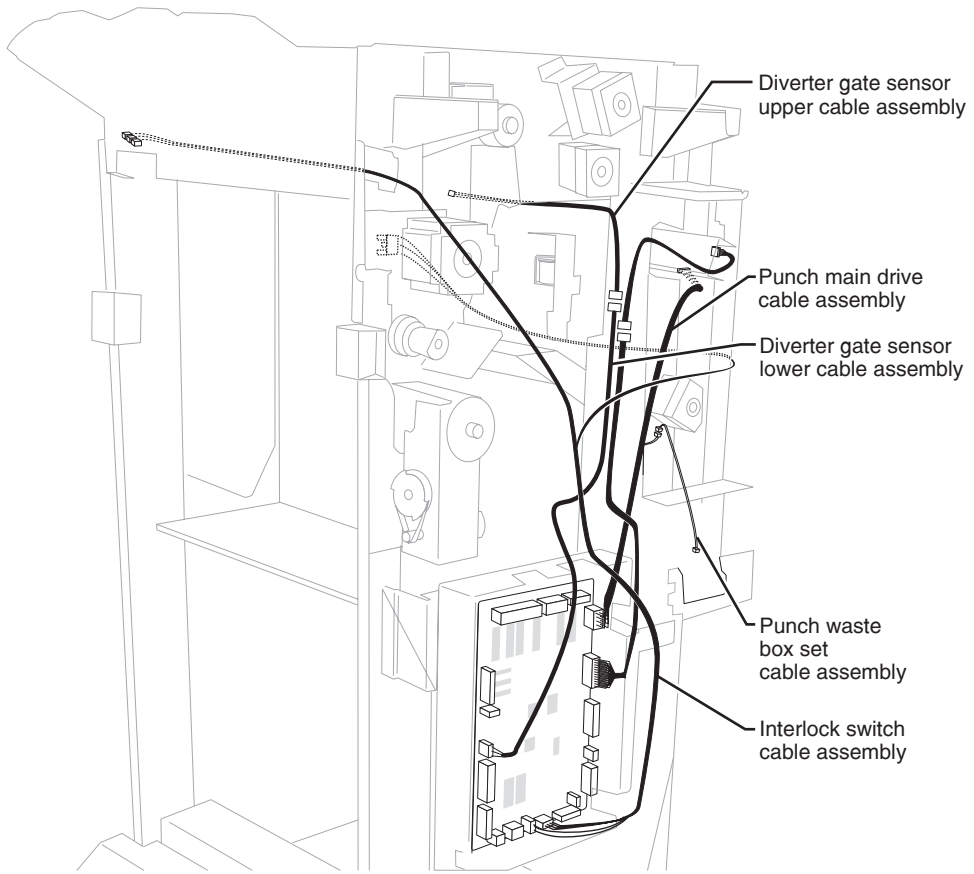

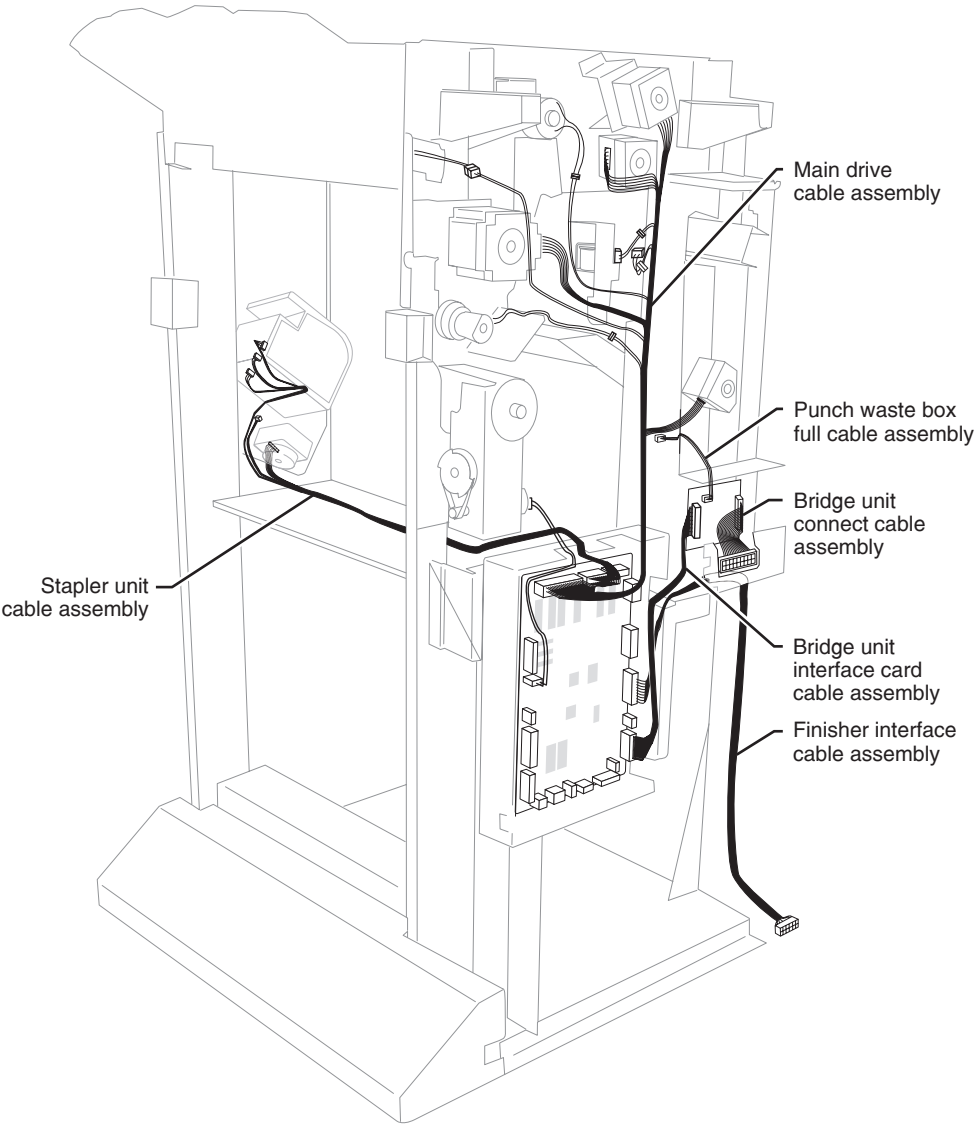

Electronic component diagram

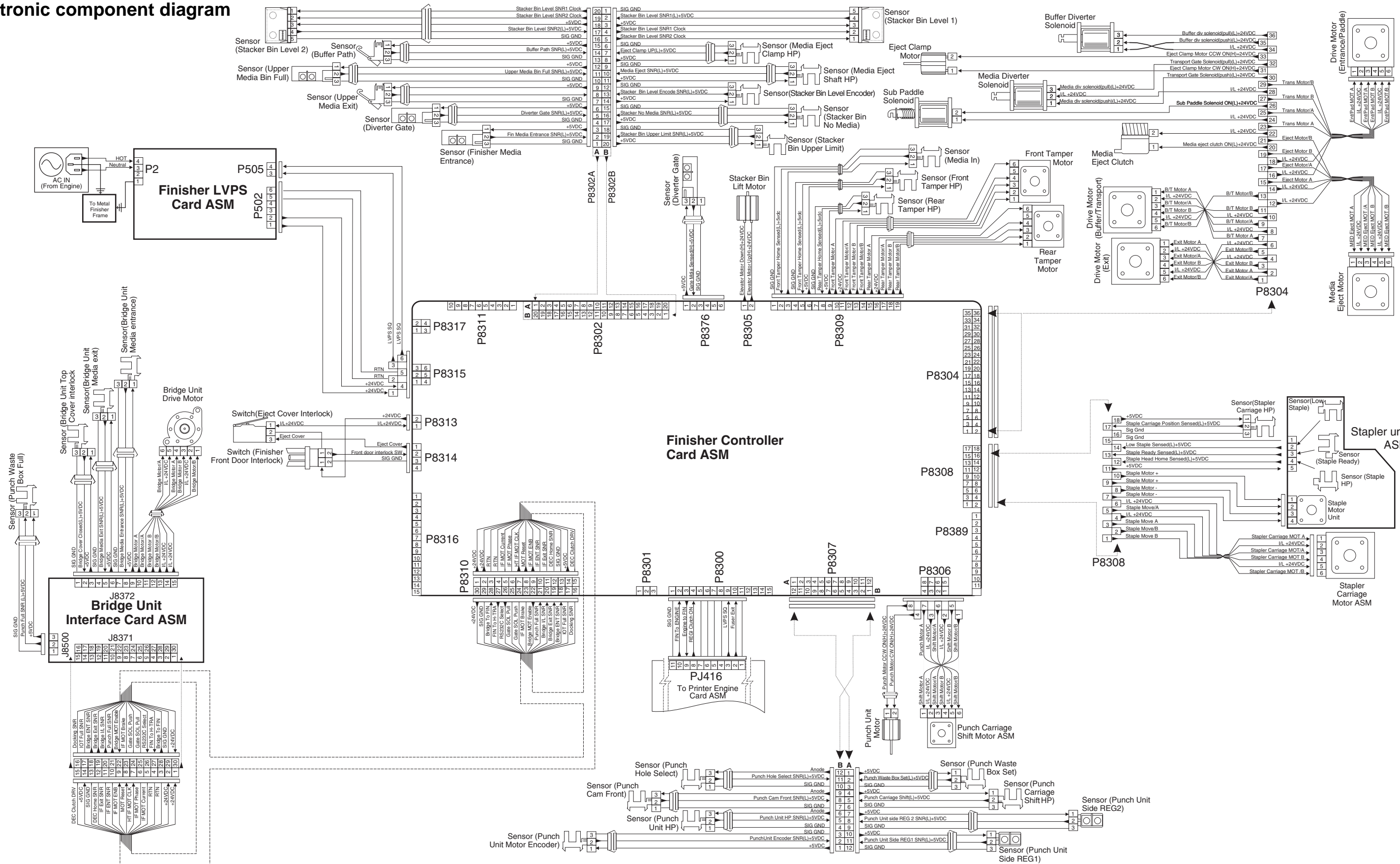

6. Preventive maintenance

This chapter describes procedures for printer preventive maintenance. Follow these recommendations to help prevent problems and maintain optimum performance.

Safety inspection guide

The purpose of this inspection guide is to aid you in identifying unsafe conditions.

If any unsafe conditions exist, find out how serious the hazard could be and if you can continue before you correct the hazard.

Check the following items:

- Damaged, missing, or altered parts, especially in the area of the on/off switch and the power supply
- Damaged, missing, or altered covers, especially in the area of the top cover and the power supply cover
- Possible safety exposure from any non-Lexmark attachments

Maintenance recommendations

| | Every service call | Every 300,000 pages |
|-------------------|-------------------------------|-------------------------------|
| Bridge unit belts | Inspect | Clean with water or alcohol |
| Main paddles (3) | Inspect | Clean with water or alcohol |
| Sub paddles (2) | Inspect | Clean with water or alcohol |
| Clamp paddles (3) | Inspect | Clean with water or alcohol |
| Punch waste box | Clean | Clean |
| Stapler cartridge | Inspect for correct operation | Inspect for correct operation |

7. Parts catalog

How to use this parts catalog

This parts catalog lists information for the finisher only. Refer to the *Printer Service Manual* for the base unit information.

The following legend is used in the parts catalog:

| Asm-Index | Part number | Units/option | Units/FRU | Description |
|-----------|-------------|--------------|-----------|-------------|
|-----------|-------------|--------------|-----------|-------------|

- **Asm-index:** Identifies the assembly and the item in the diagram. For example, 3-1 indicates Assembly 3 and item number 1 in the table.
- **Part number:** Identifies the unique number that identifies this FRU.
- **Units/option:** Refers to the number of units in a particular option. It does not include the rest of the base machine.
- **Units/FRU:** Refers to the number of units packaged together and identified by the part number.
- **NS:** (Not shown) in the Asm-Index column indicates that the part is procurable but is not pictured in the illustration.
- **PP:** (Parts Packet) in the parts description column indicates the part is contained in a parts packet.

Assembly 1: Bridge unit

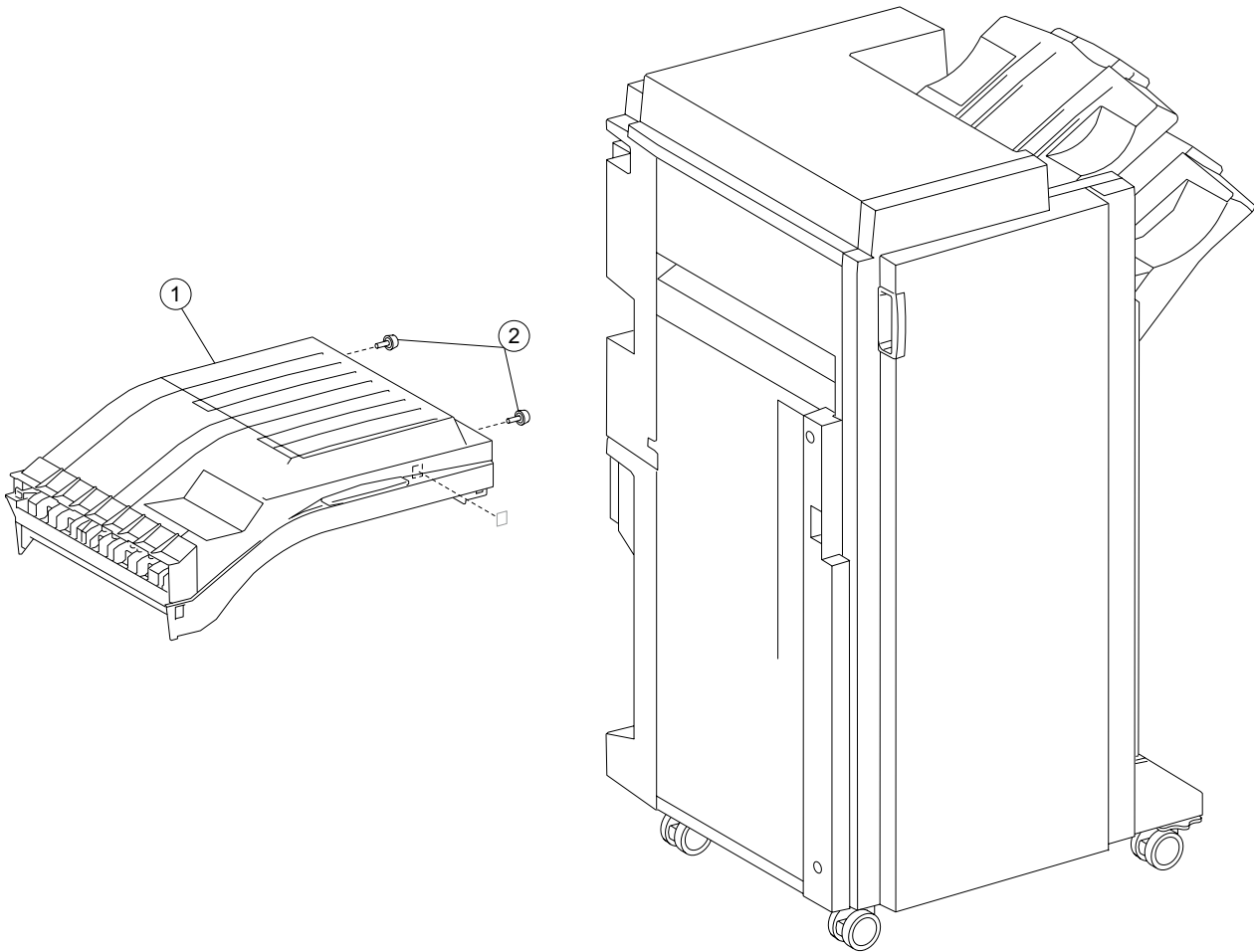

| Asm-Index | Part number | Units/option | Units/FRU | Description |
|-----------|-------------|--------------|-----------|--|
| 1—1 | 40X0811 | 1 | 1 | Bridge unit assembly |
| 2 | 40X0810 | 1 | 2 | Bridge unit assembly docking screw (2) |

Assembly 2: Bridge unit top cover assembly

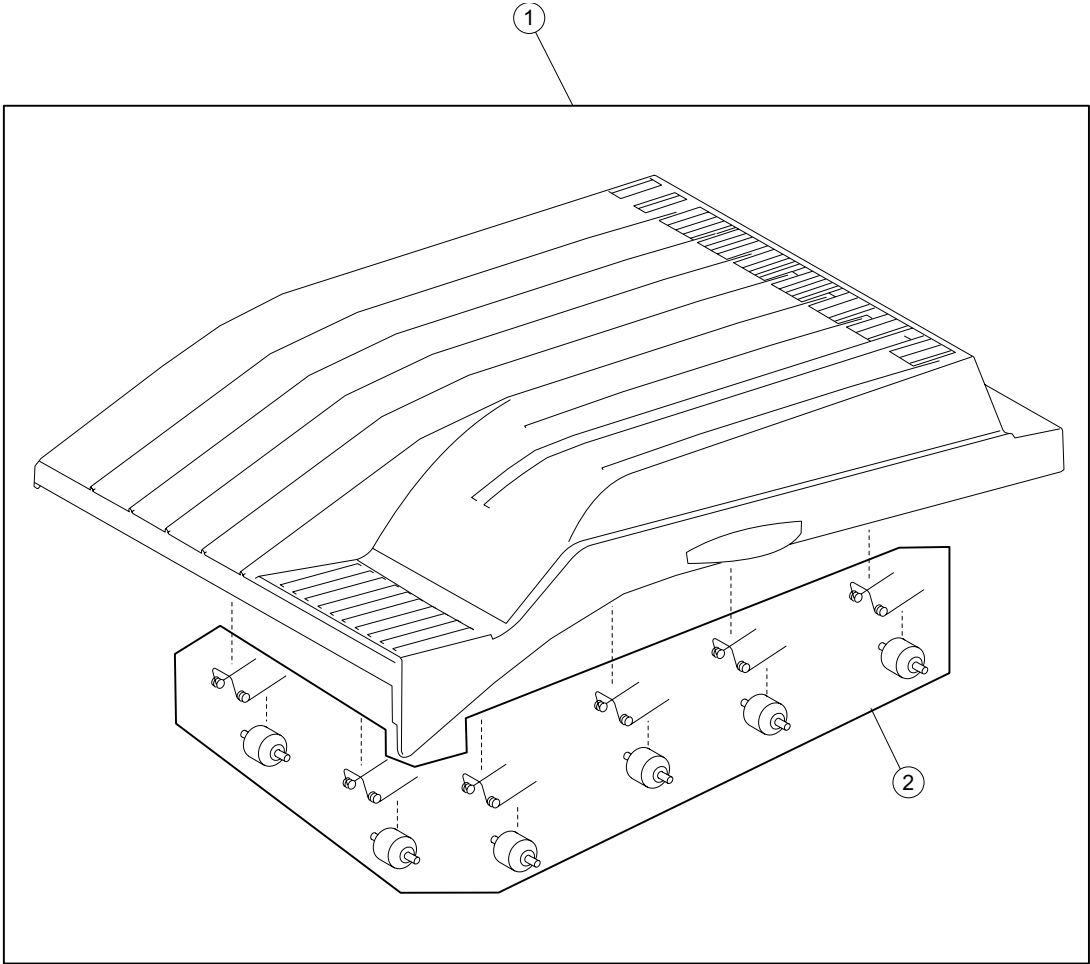

| Asm-Index | Part number | Units/option | Units/FRU | Description |
|-----------|-------------|--------------|-----------|--|
| 2—1 | 40X0813 | 1 | 1 | Bridge unit top cover assembly |
| 2 | 40X0812 | 1 | 12 | Bridge unit pinch roll kit includes: <ul style="list-style-type: none">• Bridge unit pinch roll (6)• Spring (6) |

Assembly 3: Bridge unit lower assembly

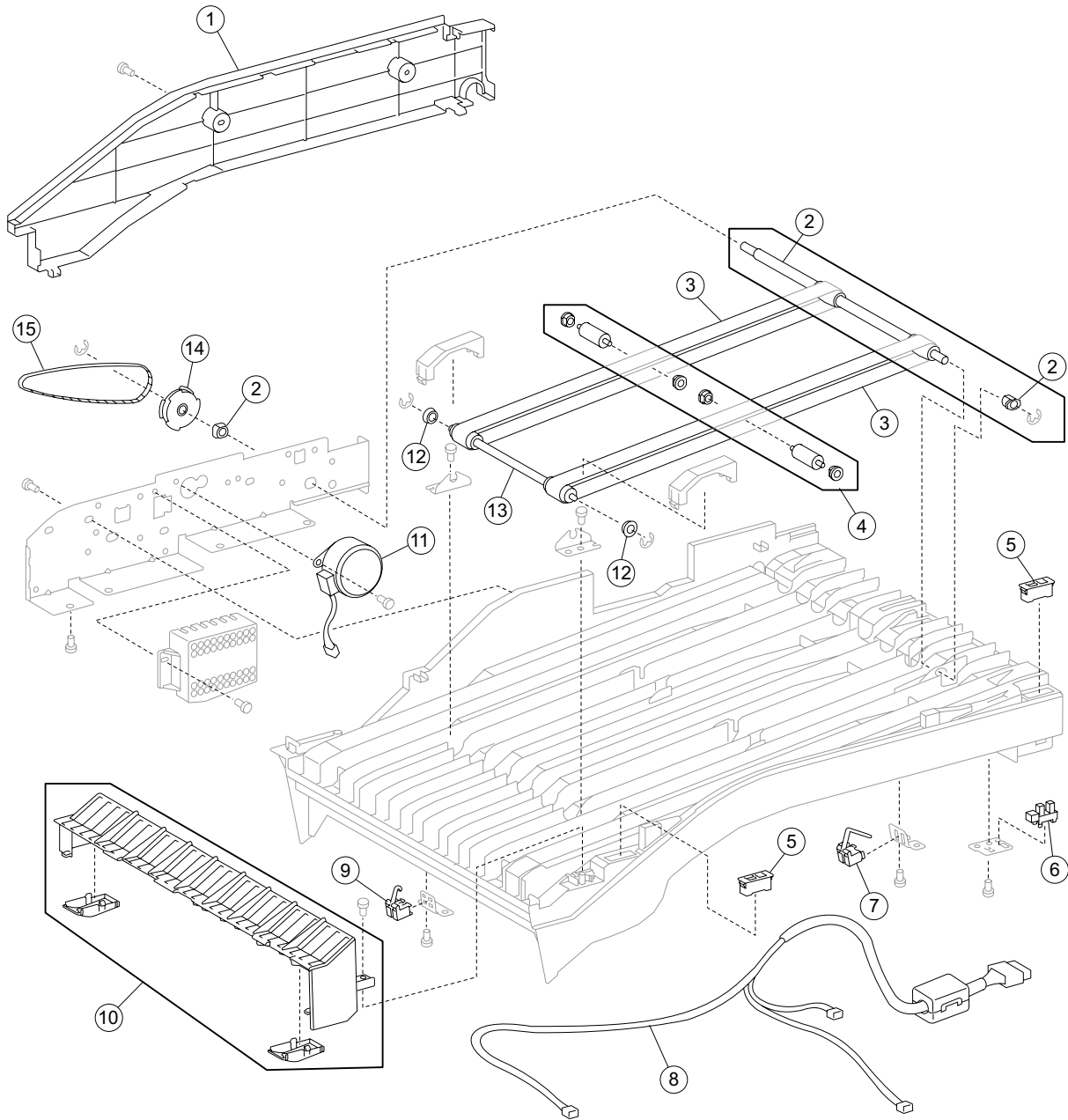

Assembly 3: Bridge unit lower assembly

| Asm-Index | Part number | Units/option | Units/FRU | Description |
|-----------|-------------|--------------|-----------|--|
| 3—1 | 40X0814 | 1 | 1 | Bridge unit rear cover |
| 2 | 40X0822 | 1 | 3 | Bridge unit right shaft kit includes: <ul style="list-style-type: none"> • 6 mm bushing • Bridge unit right shaft assembly • 6 mm bushing |
| 3 | 40X0820 | 1 | 2 | Transport belts (2) |
| 4 | 40X0821 | 1 | 6 | Idler roll kit includes: <ul style="list-style-type: none"> • Idler roll (2) • Bushing (4) |
| 5 | 40X0824 | 8 | 1 | Magnetic catch |
| 6 | 40X0825 | 1 | 1 | Sensor (bridge unit top cover interlock) |
| 7 | 40X0826 | 1 | 1 | Sensor (bridge unit media exit) |
| 8 | 40X0828 | 1 | 1 | Bridge unit cable assembly |
| 9 | 40X0827 | 1 | 1 | Sensor (bridge unit media entrance) |
| 10 | 40X0818 | 1 | 3 | Bridge unit entrance guide kit includes: <ul style="list-style-type: none"> • Entrance guide • Lower guides (2) |
| 11 | 40X0817 | 1 | 1 | Bridge unit drive motor |
| 12 | 40X0819 | 2 | 1 | 4 mm ball bearing |
| 13 | 40X0823 | 1 | 1 | Bridge unit left shaft assembly |
| 14 | 40X0816 | 1 | 1 | Bridge unit drive pulley |
| 15 | 40X0815 | 1 | 1 | Bridge unit drive belt |

Assembly 4: Covers

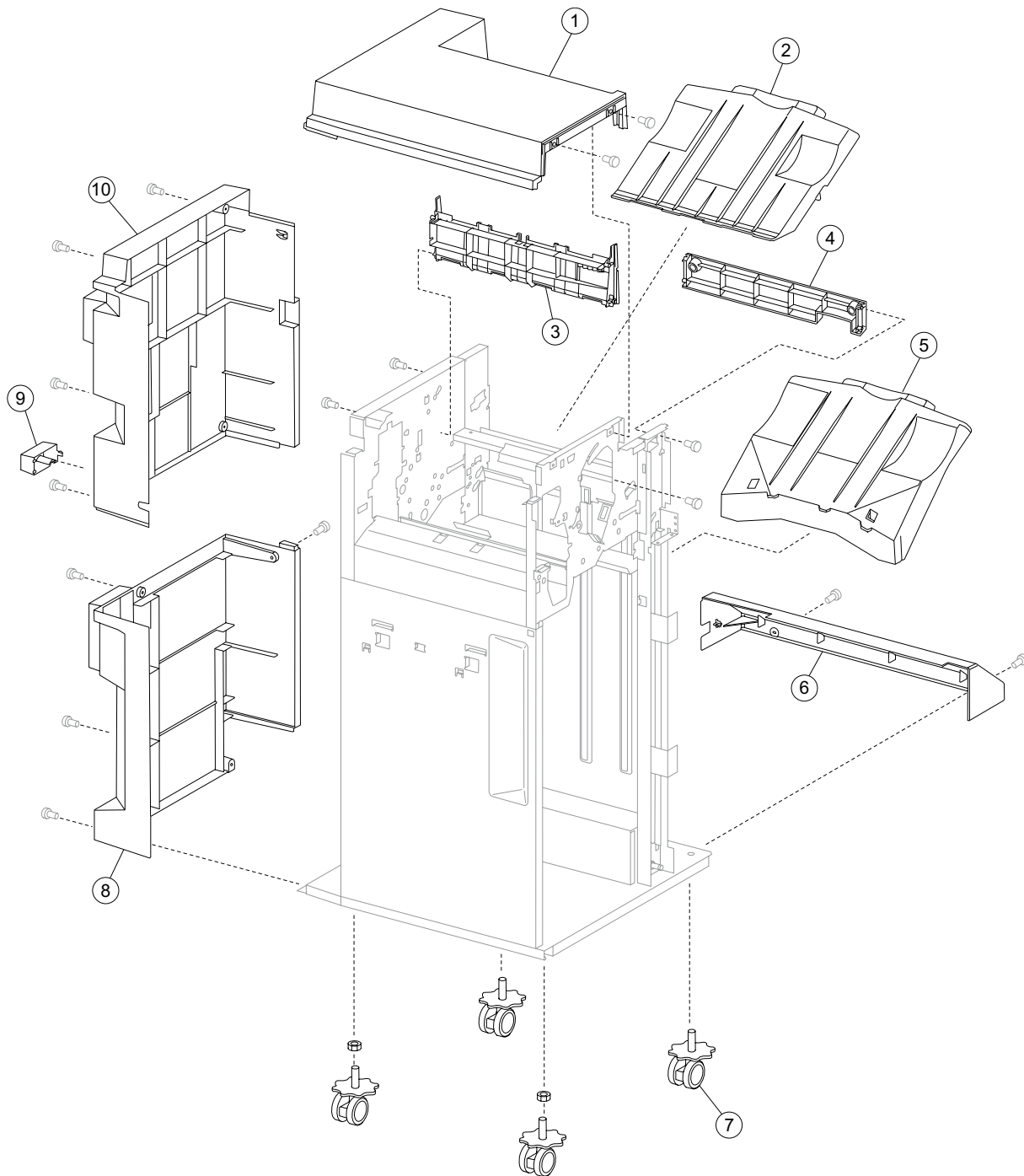

Assembly 4: Covers

| Asm-Index | Part number | Units/option | Units/FRU | Description |
|-----------|-------------|--------------|-----------|--------------------------------|
| 4—1 | 40X0829 | 1 | 1 | Top cover |
| 2 | 40X0831 | 1 | 1 | Upper media bin assembly |
| 3 | 40X0830 | 1 | 1 | Upper media bin vertical cover |
| 4 | 40X0832 | 1 | 1 | Right eject cover |
| 5 | 40X0833 | 1 | 1 | Stacker media bin |
| 6 | 40X0834 | 1 | 1 | Right lower LVPS cover |
| 7 | 40X0835 | 4 | 1 | Caster |
| 8 | 40X0836 | 1 | 1 | Rear lower cover |
| 9 | 40X0837 | 1 | 1 | Bridge unit hookup cover |
| 10 | 40X0838 | 1 | 1 | Rear upper cover |

Assembly 5: Covers and front door

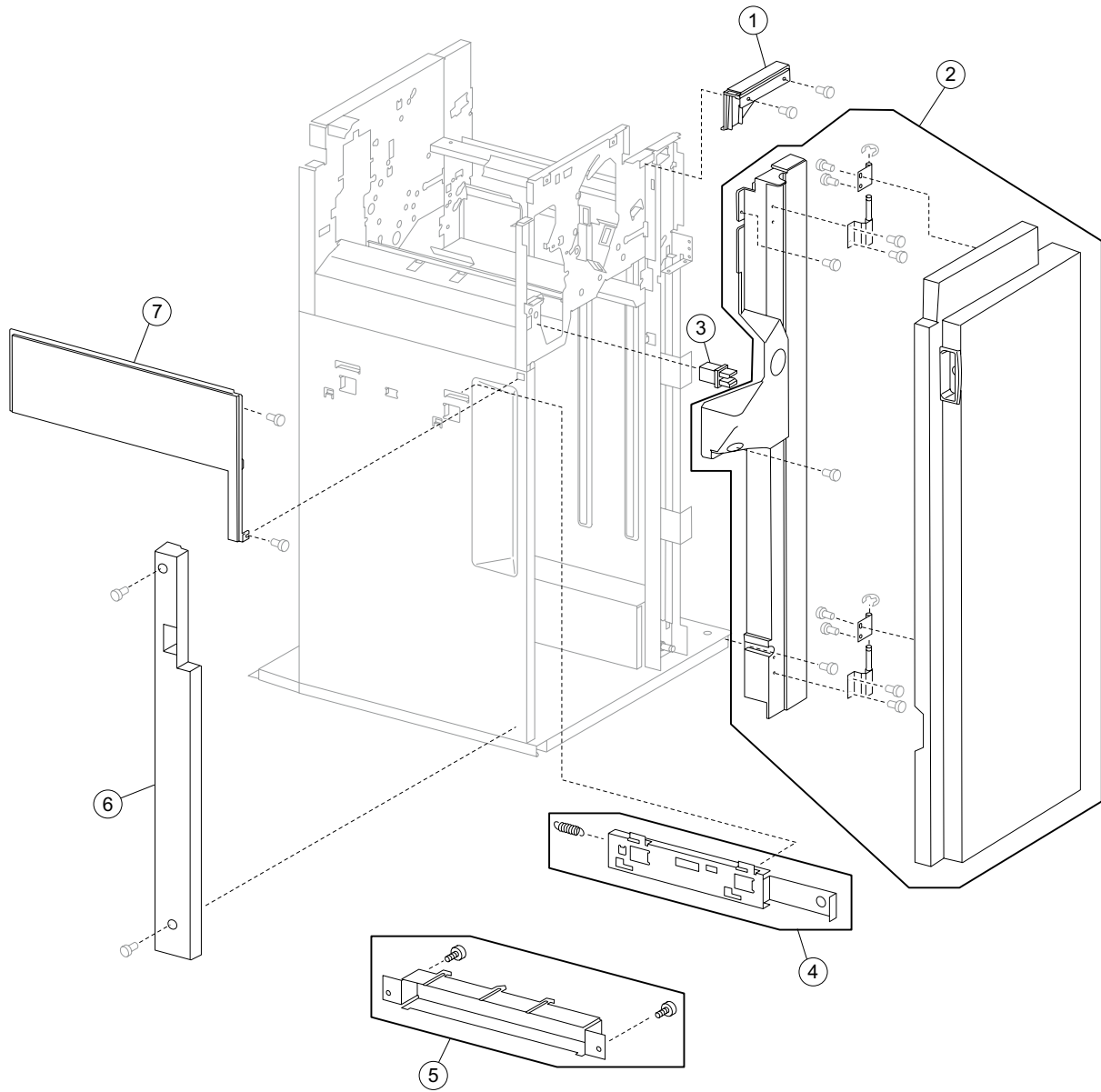

Assembly 5: Covers and front door

| Asm-Index | Part number | Units/ option | Units/ FRU | Description |
|-----------|-------------|------------------|---------------|--|
| 5—1 | 40X0839 | 1 | 1 | Upper media bin front cover |
| 2 | 40X0841 | 1 | 1 | Finisher front door assembly |
| 3 | 40X0840 | 1 | 1 | Switch (finisher front door interlock) |
| 4 | 40X0842 | 1 | 2 | Finisher docking latch kit includes: <ul style="list-style-type: none"> • Finisher docking latch assembly • Spring |
| 5 | 40X0843 | 1 | 3 | Finisher docking bracket kit includes: <ul style="list-style-type: none"> • Finisher docking bracket • Screw (2) |
| 6 | 40X0844 | 1 | 1 | Left lower cover |
| 7 | 40X0845 | 1 | 1 | Left upper cover |

Assembly 6: Stacker bin lift

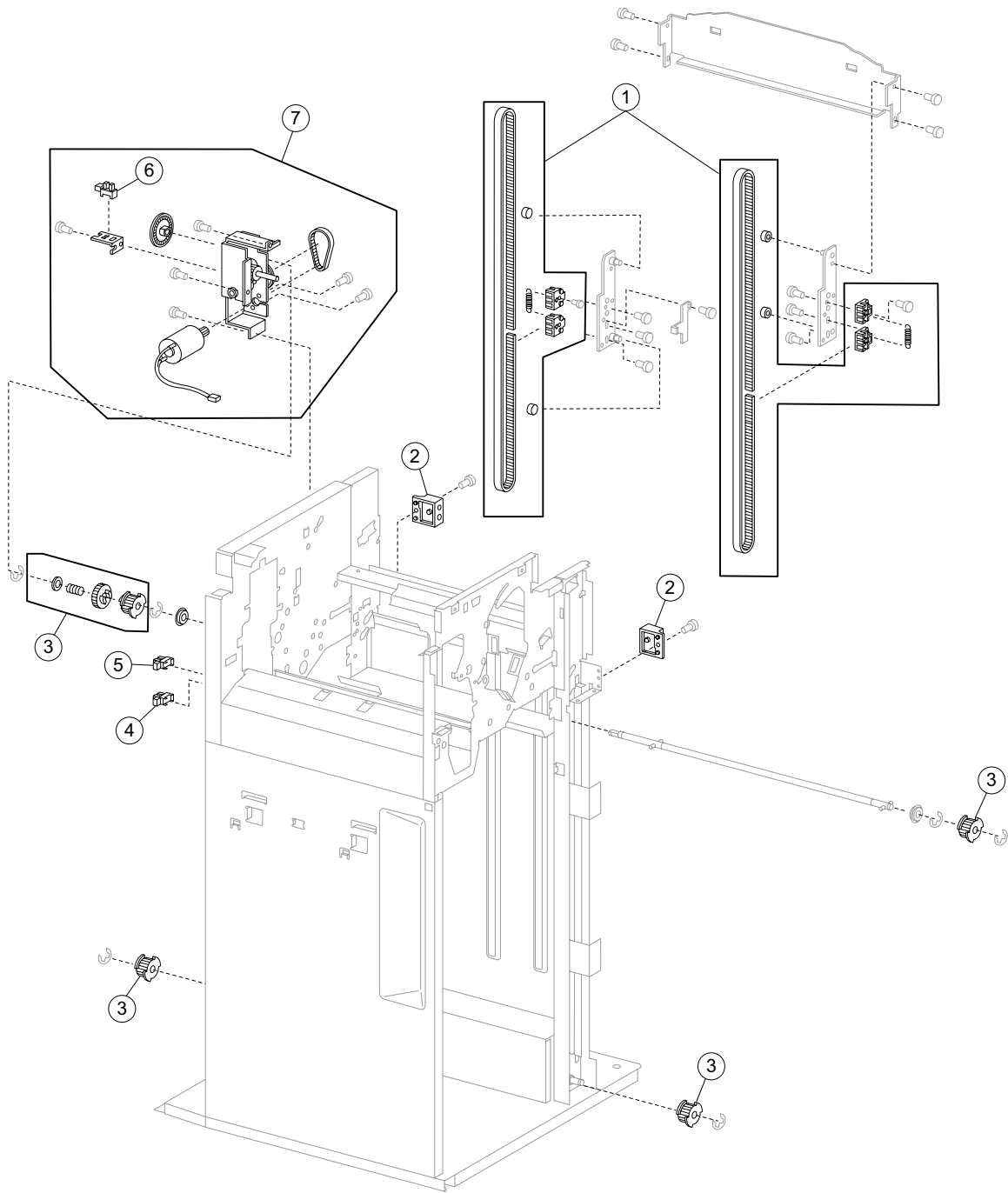

Assembly 6: Stacker bin lift

| Asm-Index | Part number | Units/ option | Units/ FRU | Description |
|-----------|-------------|------------------|---------------|--|
| 6—1 | 40X0846 | 2 | 6 | Carriage lift belt kit includes: <ul style="list-style-type: none"> • Carriage lift belt • Belt clamp (2) • Spring • Roll (2) |
| 2 | 40X0847 | 2 | 1 | Sensor (stacker bin level) |
| 3 | 40X0849 | 1 | 7 | Stacker slip clutch pulley kit includes: <ul style="list-style-type: none"> • Pulley, 18T (3) • Slip clutch pulley, 18T • Slip clutch gear, 24T • Spring • Washer |
| 4 | 40X0850 | 1 | 1 | Sensor (stacker bin no media) |
| 5 | 40X0850 | 1 | 1 | Sensor (stacker bin upper limit) |
| 6 | 40X0850 | 1 | 1 | Sensor (stacker bin level encoder) |
| 7 | 40X0848 | 2 | 1 | 10 mm ball bearing |

Assembly 7: Punch

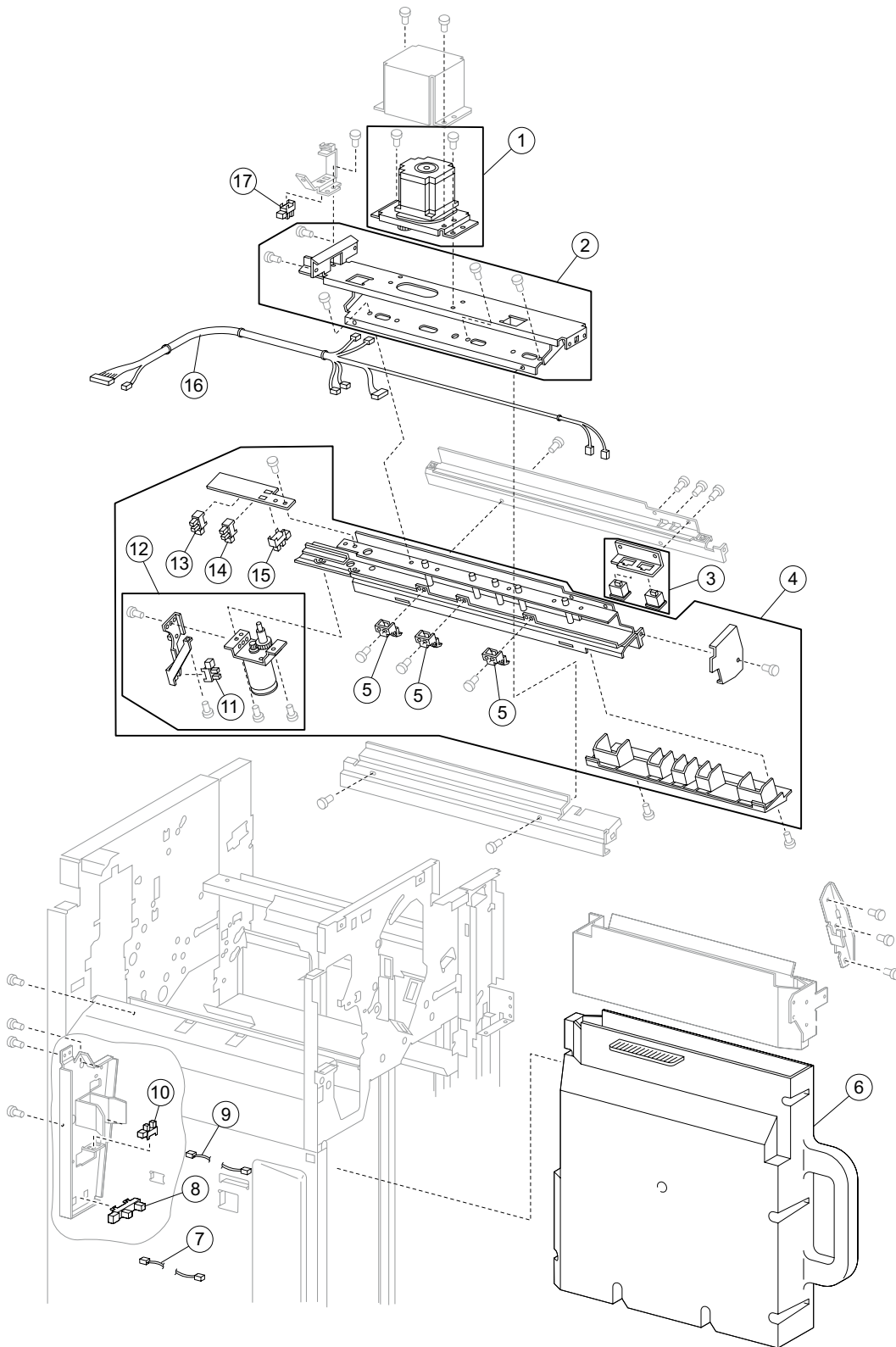

Assembly 7: Punch

| Asm-Index | Part number | Units/option | Units/FRU | Description |
|-----------|-------------|--------------|-----------|---|
| 7—1 | 40X0854 | 1 | 1 | Punch carriage shift motor assembly |
| 2 | 40X0855 | 1 | 1 | Punch carriage assembly |
| 3 | 40X0856 | 1 | 1 | Sensor (punch unit side reg) assembly <ul style="list-style-type: none"> • Sensor (punch unit side reg1) • Sensor (punch unit side reg2) • Bracket |
| 4 | 40X0857 | 1 | 1 | 2/3 punch unit assembly (this comes assembled) |
| 4 | 40X0858 | 1 | 1 | 2/4 punch unit assembly (this comes assembled) |
| 5 | 40X0859 | 3 | 1 | Punch media stopper assembly |
| 6 | 40X0862 | 1 | 1 | Punch waste box |
| 7 | 40X0930 | 1 | 1 | Punch waste box full cable assembly |
| 8 | 40X0864 | 1 | 1 | Sensor (punch waste box full) |
| 9 | 40X0865 | 1 | 1 | Punch waste box set cable assembly |
| 10 | 40X0861 | 1 | 1 | Sensor (punch waste box set) |
| 11 | 40X0850 | 1 | 1 | Sensor (punch unit motor encoder) |
| 12 | 40X0860 | 1 | 1 | Punch unit motor assembly |
| 13 | 40X0850 | 1 | 1 | Sensor (punch hole select) |
| 14 | 40X0850 | 1 | 1 | Sensor (punch cam front) |
| 15 | 40X0850 | 1 | 1 | Sensor (punch unit HP) |
| 16 | 40X0853 | 1 | 1 | Punch unit cable assembly |
| 17 | 40X0850 | 1 | 1 | Sensor (punch carriage shift HP) |

Assembly 8: Stapler

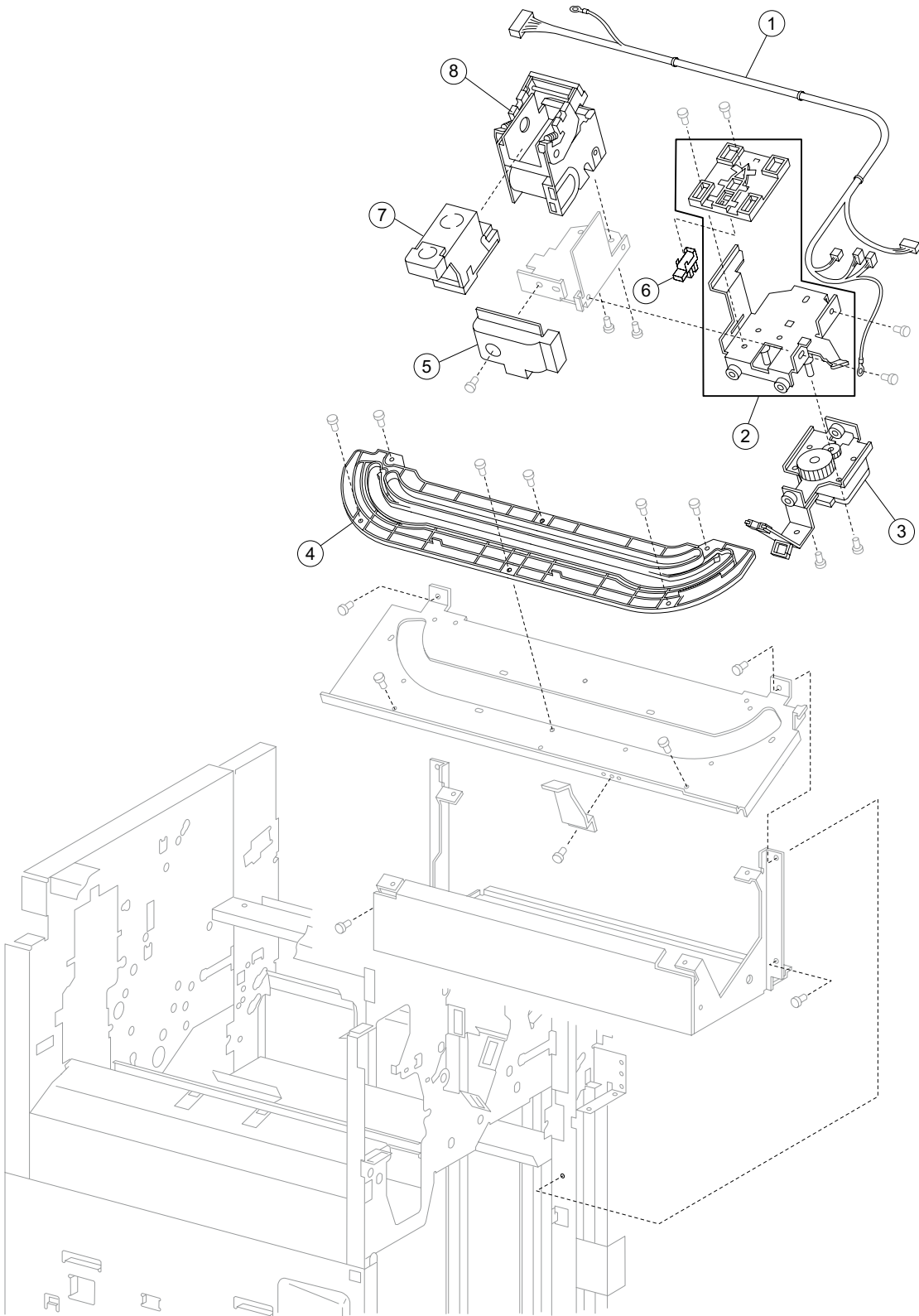

Assembly 8: Stapler

| Asm-Index | Part number | Units/option | Units/FRU | Description |
|-----------|-------------|--------------|-----------|--|
| 8—1 | 40X0870 | 1 | 1 | Stapler unit cable assembly |
| 2 | 40X0869 | 1 | 2 | Stapler carriage assembly includes: <ul style="list-style-type: none"> • Stapler carriage wire guide • Stapler carriage assembly |
| 3 | 40X0871 | 1 | 1 | Stapler carriage motor assembly |
| 4 | 40X0872 | 1 | 1 | Stapler carriage rack gear |
| 5 | 40X0868 | 1 | 1 | Stapler unit cover |
| 6 | 40X0850 | 1 | 1 | Sensor (stapler carriage HP) |
| 7 | 40X0866 | 1 | 1 | Staple cartridge |
| 8 | 40X0867 | 1 | 1 | Stapler unit assembly |

Assembly 9: Media eject

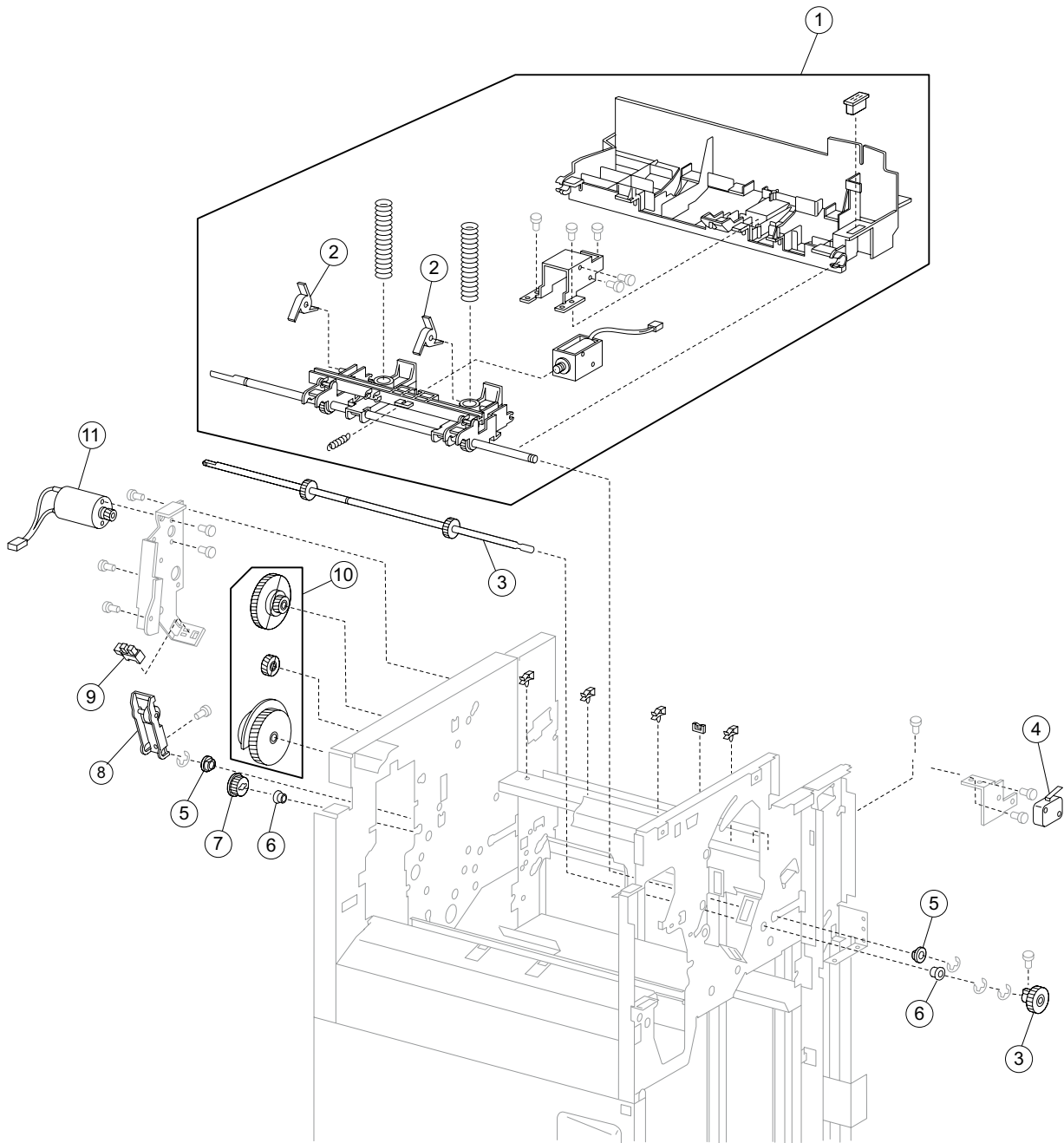

Assembly 9: Media eject

| Asm-Index | Part number | Units/option | Units/FRU | Description |
|-----------|-------------|--------------|-----------|--|
| 9—1 | 40X0873 | 1 | 1 | Media eject unit assembly (this comes assembled) |
| 2 | 40X0874 | 2 | 1 | Sub paddle |
| 3 | 40X0875 | 1 | 2 | Sub paddle drive shaft kit includes: <ul style="list-style-type: none"> • Sub paddle drive shaft assembly • Knob |
| 4 | 40X0882 | 1 | 1 | Switch (eject cover interlock) |
| 5 | 40X0878 | 4 | 1 | 8 mm bushing |
| 6 | 40X0888 | 15 | 1 | 6 mm bushing |
| 7 | 40X0879 | 2 | 2 | Sub paddle/entrance drive gear 23T |
| 8 | 40X0877 | 1 | 1 | Eject clamp lever assembly |
| 9 | 40X0825 | 1 | 1 | Sensor (media eject shaft HP) |
| 10 | 40X0881 | 1 | 3 | Eject clamp gear kit includes: <ul style="list-style-type: none"> • Eject clamp gear 70T • Eject clamp gear 23T • Eject clamp gear 68/20T |
| 11 | 40X0876 | 1 | 1 | Media eject clamp motor |

Assembly 10: Eject and compiler unit

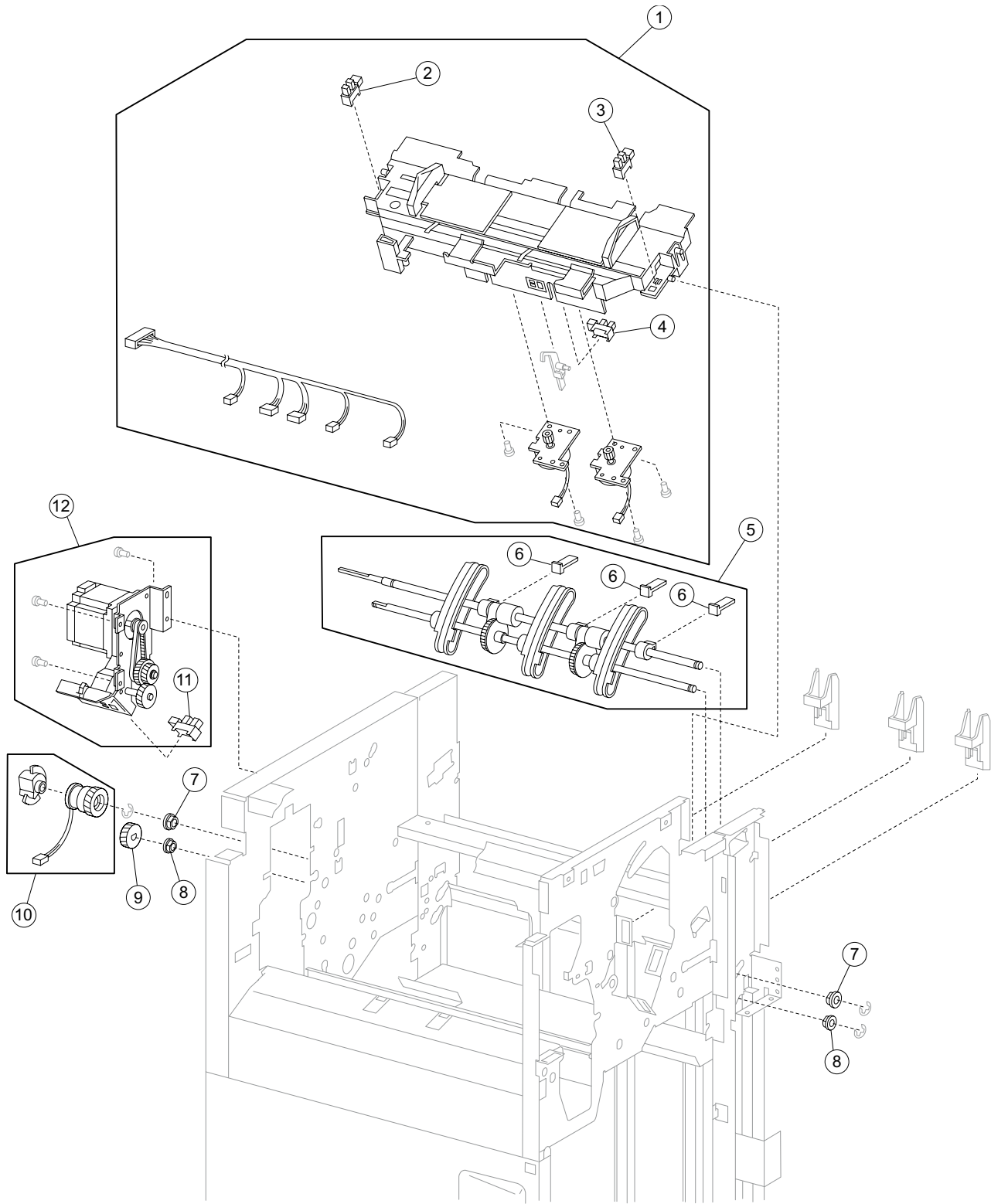

Assembly 10: Eject and compiler unit

| Asm-Index | Part number | Units/option | Units/FRU | Description |
|-----------|-------------|--------------|-----------|--|
| 10—1 | 40X0883 | 1 | 1 | Media compiler unit assembly (this comes assembled) |
| 2 | 40X0850 | 1 | 1 | Sensor (rear tamper HP) |
| 3 | 40X0850 | 1 | 1 | Sensor (front tamper HP) |
| 4 | 40X0825 | 1 | 1 | Sensor (compiler media in) |
| 5 | 40X0886 | 1 | 1 | Media eject shaft assembly |
| 6 | 40X0887 | 3 | 1 | Clamp paddle |
| 7 | 40X0888 | 15 | 1 | 6 mm bushing |
| 8 | 40X0878 | 4 | 1 | 8 mm bushing |
| 9 | 40X0889 | 2 | 1 | Media eject shaft gear 39T |
| 10 | 40X0890 | 1 | 2 | Media eject clutch kit includes: <ul style="list-style-type: none"> • Media eject clutch • Media eject clutch actuator |
| 11 | 40X0825 | 1 | 1 | Sensor (media eject shaft HP) |
| 12 | 40X0891 | 1 | 1 | Media eject motor assembly |

Assembly 11: Lower exit drive

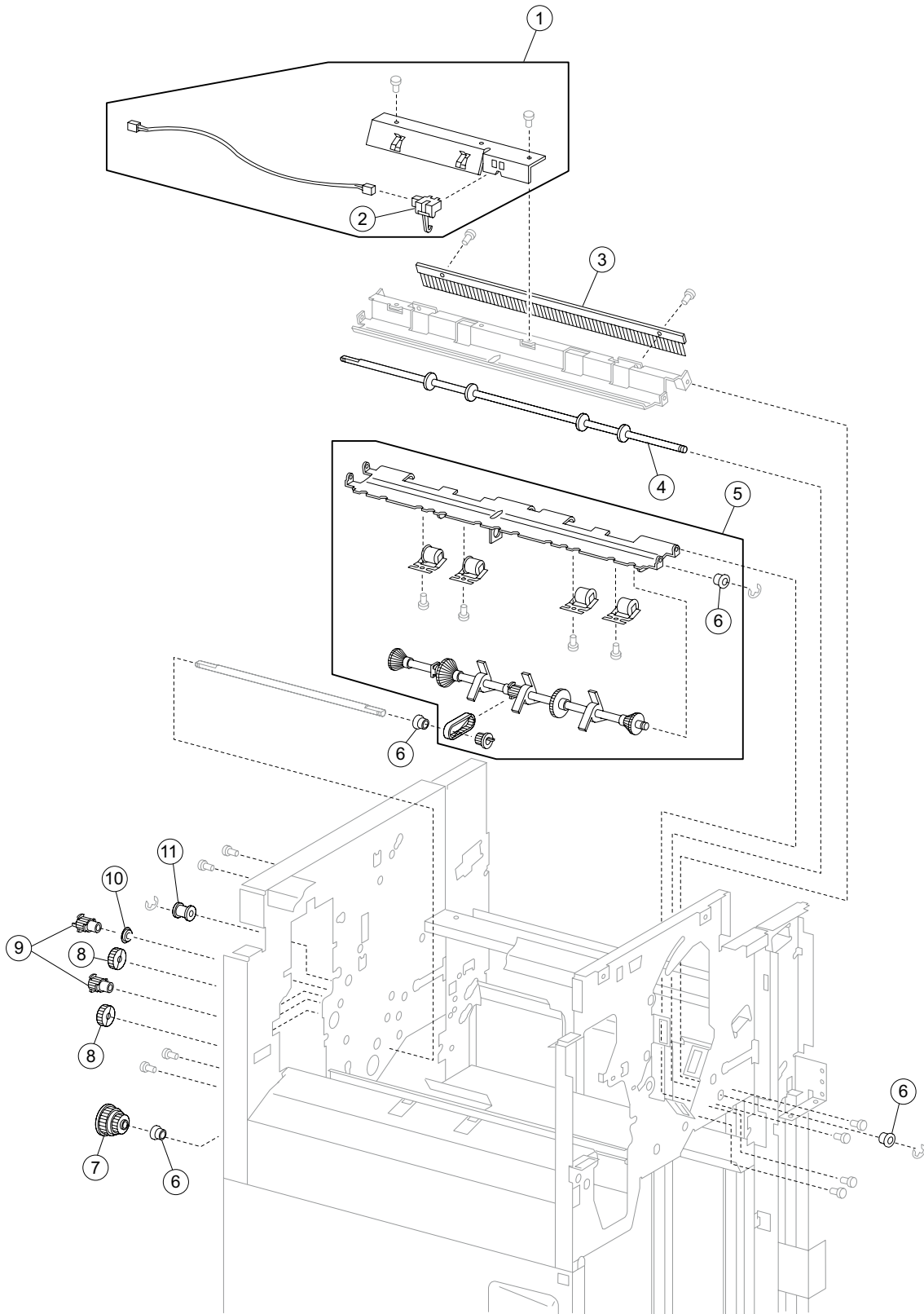

Assembly 11: Lower drive

| Asm-Index | Part number | Units/ option | Units/ FRU | Description |
|-----------|-------------|------------------|---------------|---|
| 11—1 | 40X0892 | 1 | 1 | Sensor (lower media exit) with bracket |
| 2 | 40X0893 | 1 | 1 | Sensor (lower media exit) |
| 3 | 40X0894 | 1 | 1 | Static eliminator brush |
| 4 | 40X0895 | 1 | 1 | Lower media exit roll assembly |
| 5 | 40X0896 | 1 | 2 | Main paddle shaft kit includes: (this comes assembled) <ul style="list-style-type: none"> • Main paddle shaft assembly • Main paddle shaft drive pulley 17T |
| 6 | 40X0888 | 15 | 1 | 6 mm bushing |
| 7 | 40X0900 | 1 | 1 | Main paddle drive pulley/gear 44/20T |
| 8 | 40X0899 | 1 | 2 | Main paddle idler gear kit includes: <ul style="list-style-type: none"> • Main paddle idler gear 23TR • Main paddle idler gear 23TL |
| 9 | 40X0898 | 1 | 2 | Lower exit roll pulley kit includes: <ul style="list-style-type: none"> • Lower exit roll drive pulley 20T • Idler pulley 20T |
| 10 | 40X0913 | 4 | 1 | 6 mm ball bearing |
| 11 | 40X0897 | 3 | 1 | Belt idler pulley |

Assembly 12: Buffer and entrance drive

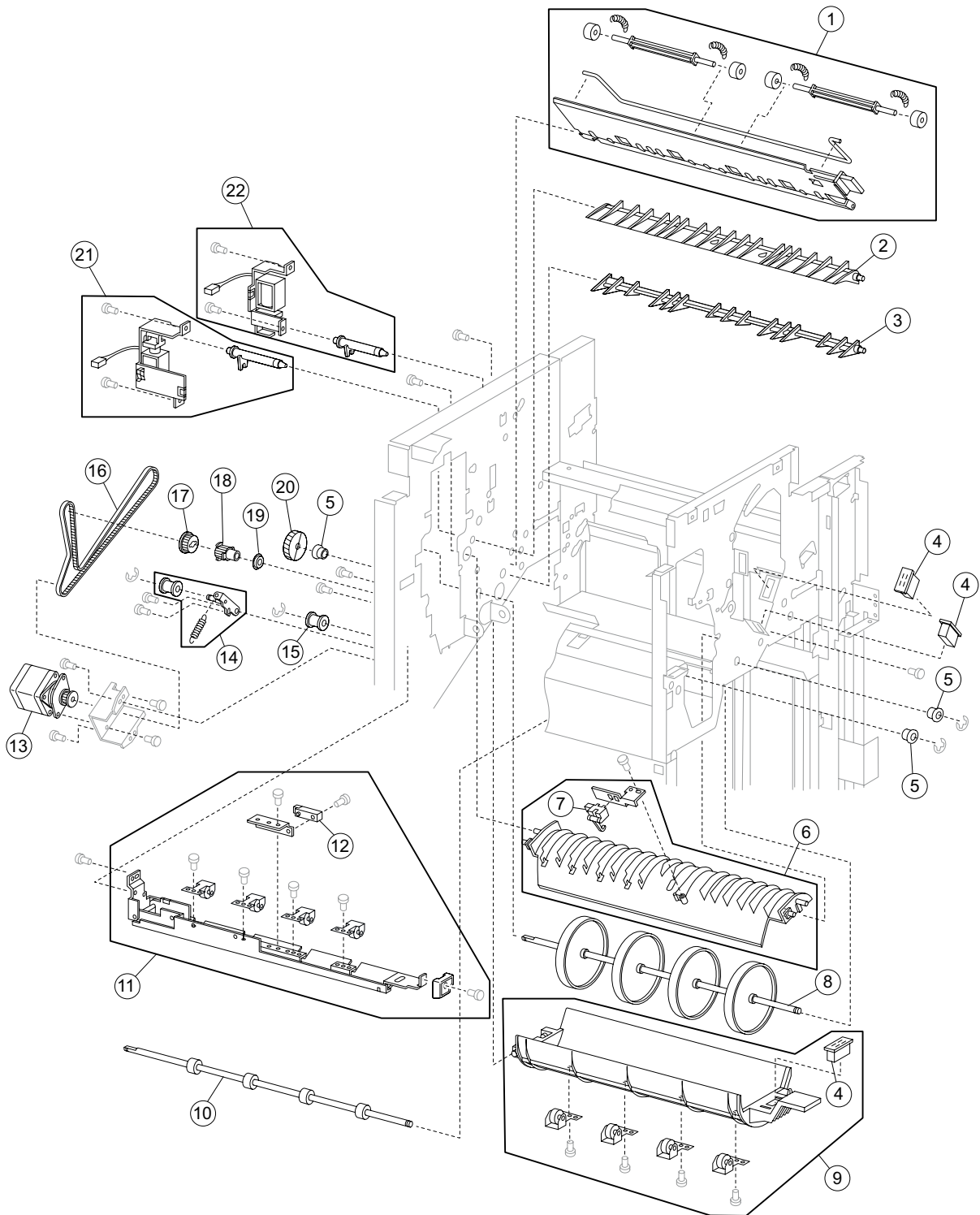

Assembly 12: Buffer and entrance drive

| Asm-Index | Part number | Units/ option | Units/ FRU | Description |
|-----------|-------------|------------------|---------------|---|
| 12—1 | 40X0901 | 1 | 1 | Lower pinch guide assembly (this comes assembled) |
| 2 | 40X0902 | 1 | 1 | Media diverter gate |
| 3 | 40X0903 | 1 | 1 | Buffer diverter gate |
| 4 | 40X0824 | 8 | 1 | Magnetic catch |
| 5 | 40X0888 | 15 | 1 | 6 mm bushing |
| 6 | 40X0904 | 1 | 1 | Buffer upper guide assembly |
| 7 | 40X0893 | 1 | 1 | Sensor (buffer path) |
| 8 | 40X0905 | 1 | 1 | Buffer roll assembly |
| 9 | 40X0906 | 1 | 1 | Buffer pinch guide assembly (this comes assembled) |
| 10 | 40X0909 | 1 | 1 | Media entrance roll assembly |
| 11 | 40X0907 | 1 | 1 | Media entrance pinch guide assembly (this comes assembled) |
| 12 | 40X0908 | 1 | 1 | Sensor (finisher media entrance) |
| 13 | 40X0910 | 1 | 1 | Drive motor (entrance/paddle) |
| 14 | 40X0912 | 3 | 3 | Belt tensioner pulley kit includes: <ul style="list-style-type: none"> • Belt idler pulley • Spring • Belt tensioner bracket |
| 15 | 40X0897 | 3 | 1 | Belt idler pulley |
| 16 | 40X0911 | 1 | 1 | Belt entrance/paddle, 31.6 cm |
| 17 | 40X0879 | 2 | 1 | Sub paddle/entrance drive gear 23T |
| 18 | 40X0914 | 1 | 1 | Media entrance roll drive pulley 20T |
| 19 | 40X0913 | 4 | 1 | 6 mm ball bearing |
| 20 | 40X0915 | 1 | 1 | Buffer roll drive gear 46T |
| 21 | 40X0916 | 1 | 2 | Media diverter solenoid kit includes: <ul style="list-style-type: none"> • Media diverter solenoid • Media diverter solenoid link |
| 22 | 40X0917 | 1 | 2 | Buffer diverter solenoid kit includes: <ul style="list-style-type: none"> • Buffer diverter solenoid • Buffer diverter solenoid link |

Assembly 13: Buffer, transport, and upper drive

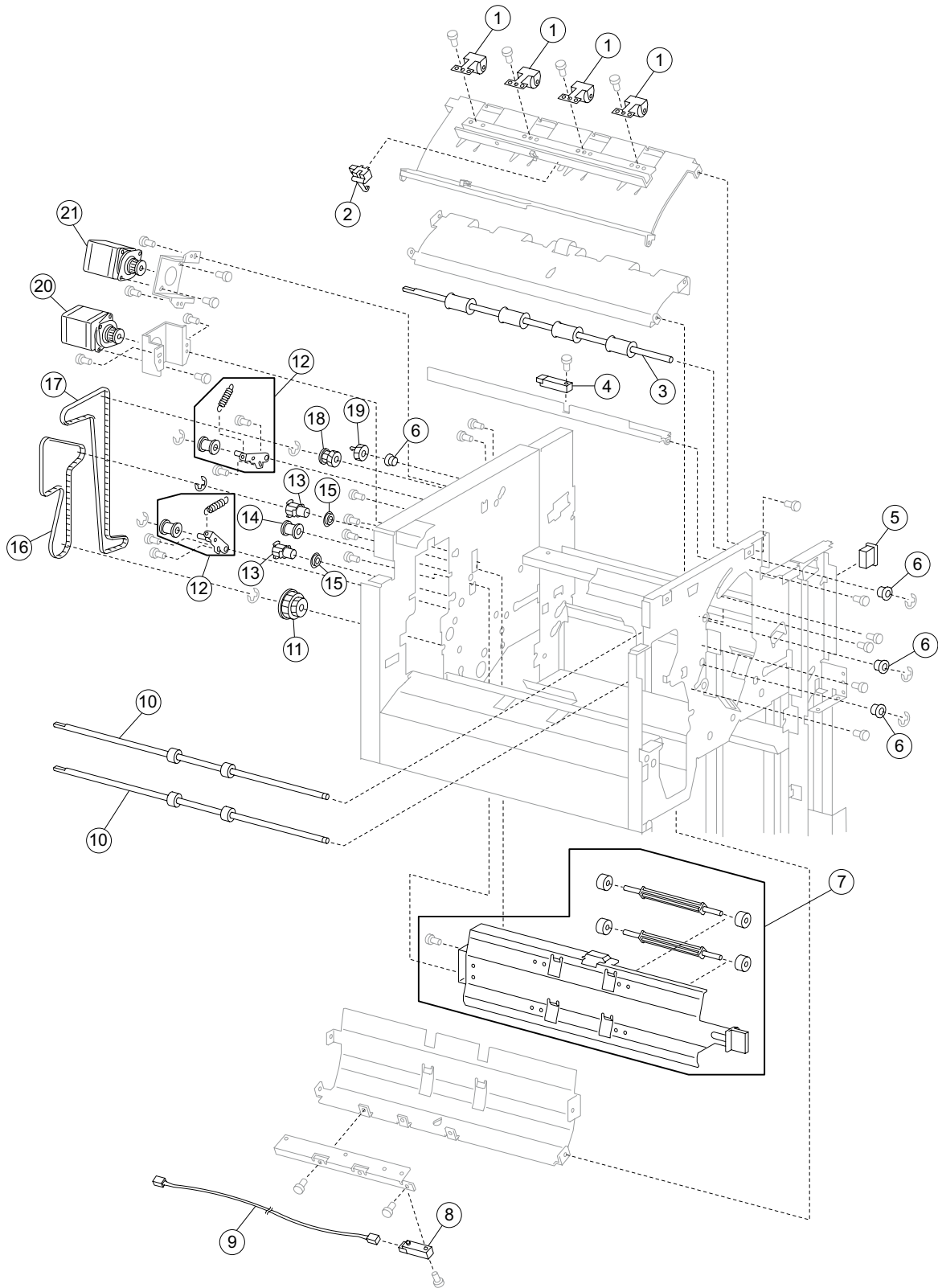

Assembly 13: Transport and upper drive

| Asm-Index | Part number | Units/option | Units/FRU | Description |
|-----------|-------------|--------------|-----------|--|
| 13—1 | 40X0918 | 4 | 1 | Upper media exit pinch roll assembly |
| 2 | 40X0893 | 1 | 1 | Sensor (upper media exit) |
| 3 | 40X0919 | 1 | 1 | Upper media exit roll assembly |
| 4 | 40X0908 | 1 | 1 | Sensor (upper media bin full) |
| 5 | 40X0824 | 8 | 1 | Magnetic catch |
| 6 | 40X0888 | 15 | 1 | 6 mm bushing |
| 7 | 40X0920 | 1 | 1 | Upper pinch guide assembly (this comes assembled) |
| 8 | 40X0921 | 1 | 1 | Sensor (diverter gate) |
| 9 | 40X0922 | 1 | 1 | Diverter gate sensor cable lower assembly |
| 10 | 40X0923 | 2 | 1 | Upper media transport roll assembly |
| 11 | 40X0924 | 1 | 1 | Buffer roll drive pulley/gear 53/23T |
| 12 | 40X0912 | 3 | 3 | Belt tensioner bracket kit includes: <ul style="list-style-type: none"> • Belt idler pulley • Spring • Belt tensioner bracket |
| 13 | 40X0925 | 2 | 1 | Upper media transport roll drive pulley 20T |
| 14 | 40X0897 | 3 | 1 | Belt idler pulley |
| 15 | 40X0913 | 4 | 1 | 6 mm ball bearing |
| 16 | 40X0928 | 1 | 1 | Belt (buffer transport) 19.8 cm |
| 17 | 40X0929 | 1 | 1 | Belt (exit) 27.7 cm |
| 18 | 40X0926 | 1 | 1 | Upper media exit roll drive pulley/gear, 20T/20T |
| 19 | 40X0927 | 1 | 1 | Upper media exit roll drive gear 20T |
| 20 | 40X0910 | 1 | 1 | Drive motor (buffer/transport) |
| 21 | 40X0910 | 1 | 1 | Drive motor (exit) |

Assembly 14: Electronics

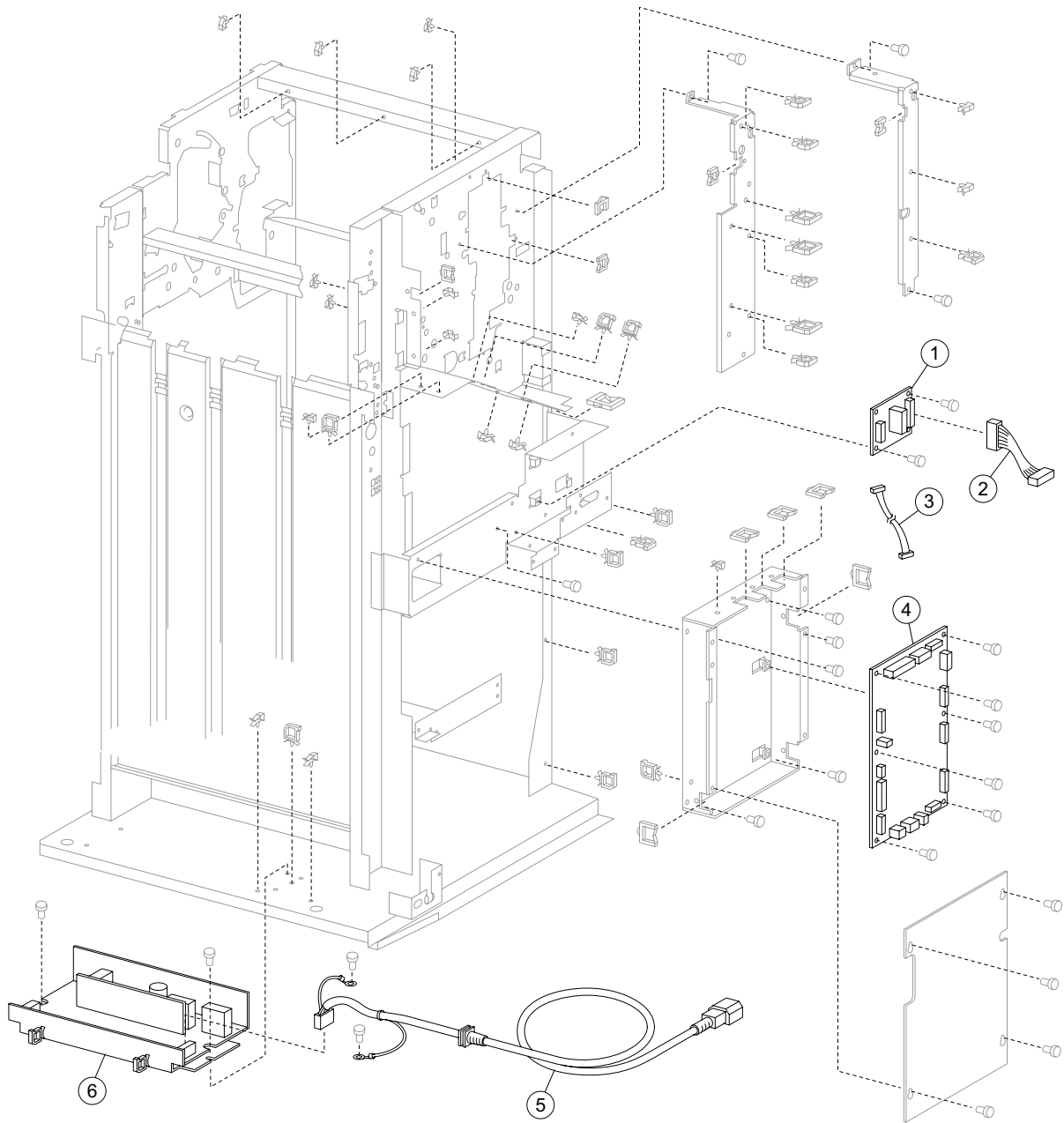

Assembly 14: Electronics

| Asm-Index | Part number | Units/option | Units/FRU | Description |
|-----------|-------------|--------------|-----------|---|
| 14—1 | 40X0931 | 1 | 1 | Bridge unit interface card assembly |
| 2 | 40X0932 | 1 | 1 | Bridge unit connect cable assembly |
| 3 | 40X0933 | 1 | 1 | Bridge unit interface card cable assembly |
| 4 | 40X0934 | 1 | 1 | Finisher controller card assembly |
| 5 | 40X0935 | 1 | 1 | AC power cord assembly |
| 6 | 40X0936 | 1 | 1 | Finisher LVPS card assembly |

Assembly 15: Cables 1

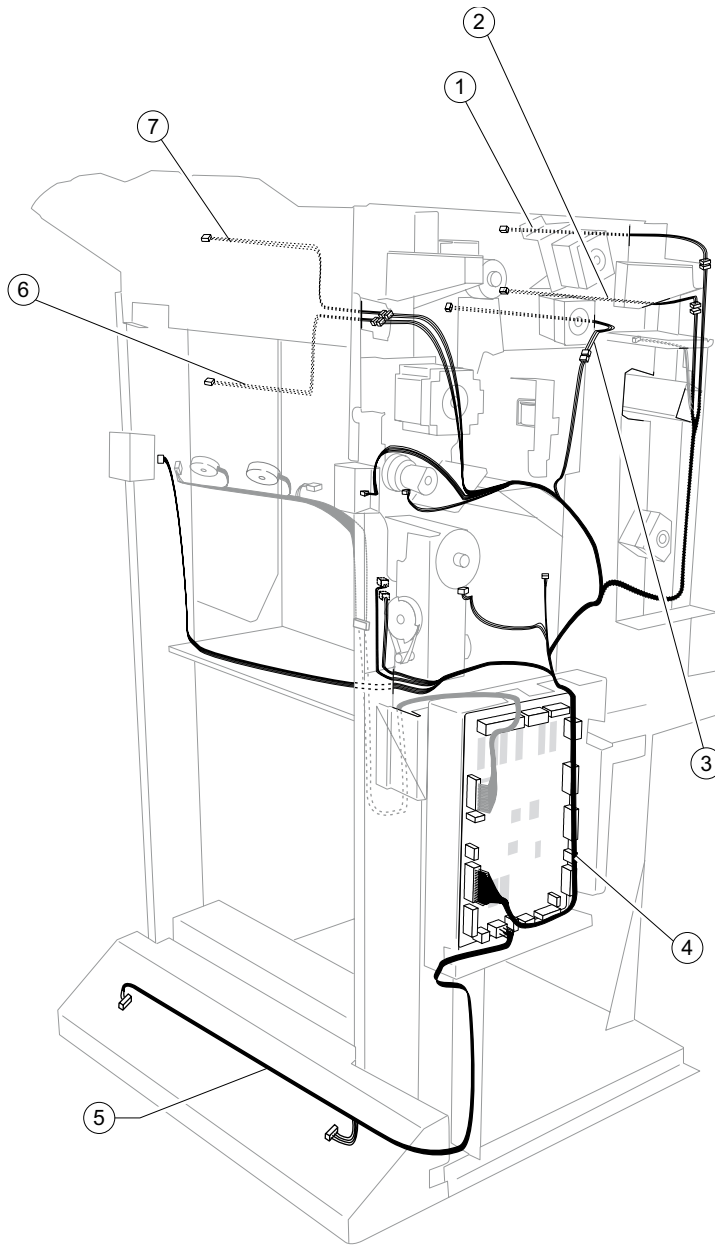

Assembly 15: Cables 1

| Asm-Index | Part number | Units/option | Units/FRU | Description |
|-----------|-------------|--------------|-----------|---|
| 15—1 | 40X0942 | 1 | 1 | Upper media sensor exit cable assembly |
| 2 | 40X0940 | 1 | 1 | Finisher media entrance sensor cable assembly |
| 3 | 40X0941 | 1 | 1 | Buffer path sensor cable assembly |
| 4 | 40X0937 | 1 | 1 | Main sensor cable assembly |
| 5 | 40X0946 | 1 | 1 | LVPS cable assembly |
| 6 | 40X0892 | 1 | 3 | Sensor (lower media exit) assembly <ul style="list-style-type: none"> • Sensor (lower media exit) • Lower media exit sensor cable assembly • Bracket |
| 7 | 40X0943 | 1 | 1 | Upper media bin full sensor cable assembly |

Assembly 16: Cables 2

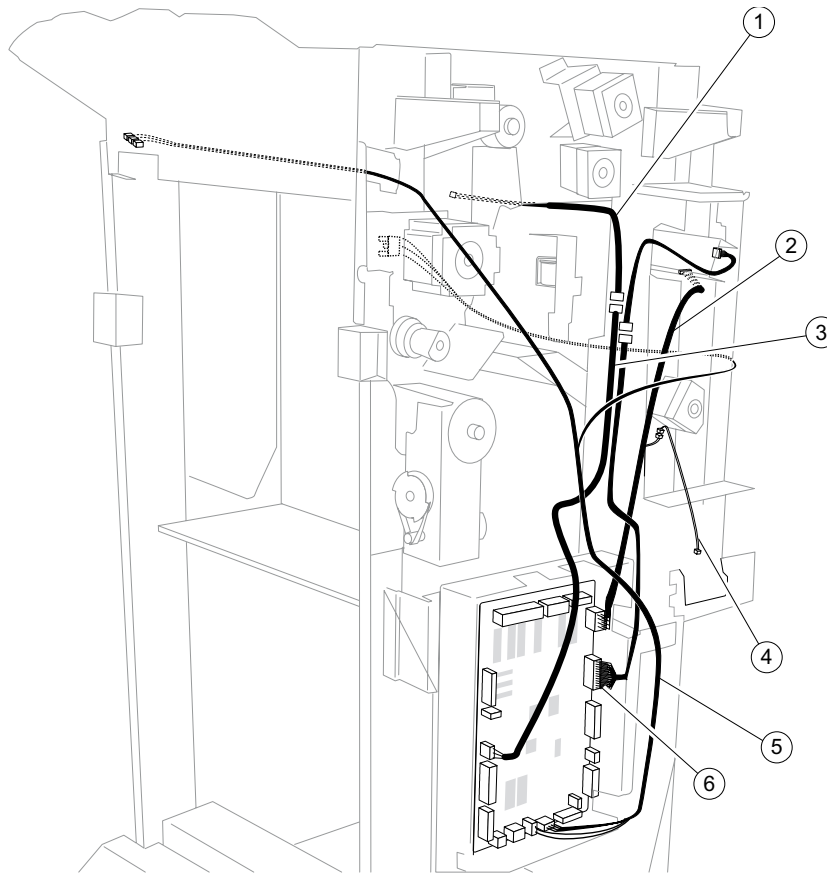

| Asm-Index | Part number | Units/ option | Units/ FRU | Description |
|-----------|-------------|------------------|---------------|---|
| 16—1 | 40X0922 | 1 | 1 | Diverter gate sensor upper cable assembly |
| 2 | 40X0944 | 1 | 1 | Punch main drive cable assembly |
| 3 | 40X0950 | 1 | 1 | Diverter gate sensor lower cable assembly |
| 4 | 40X0865 | 1 | 1 | Punch waste box set cable assembly |
| 5 | 40X0947 | 1 | 1 | Interlock switch cable assembly |
| 6 | 40X0945 | 1 | 1 | Punch main sensor cable assembly |

Assembly 17: Cables 3

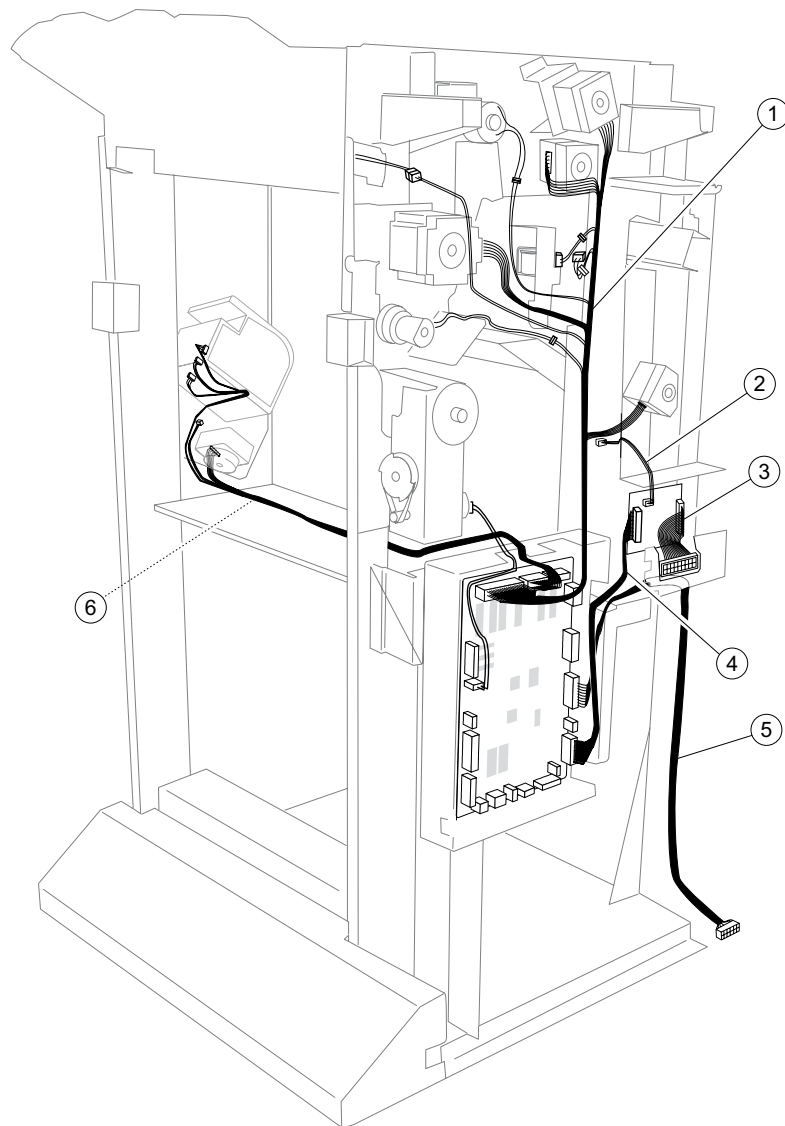

| Asm-Index | Part number | Units/option | Units/FRU | Description |
|-----------|-------------|--------------|-----------|-------------------------------------|
| 17—1 | 40X0938 | 1 | 1 | Main drive cable assembly |
| 2 | 40X0930 | 1 | 1 | Punch waste box full cable assembly |
| 3 | 40X0932 | 1 | 1 | Bridge unit connect cable assembly |
| 4 | 40X0931 | 1 | 1 | Bridge unit interface card assembly |
| 5 | 40X0939 | 1 | 1 | Finisher interface cable assembly |
| 6 | 40X0870 | 1 | 1 | Stapler unit cable assembly |

Index

A

acronyms **1-5**

B

belts

buffer/transport **4-115**
 entrance/paddle **4-100**
 exit **4-113**

bridge unit

bridge unit interface card assembly **4-117**
 drive belt **4-8**
 drive motor **5-1**
 drive pulley **4-8**
 drive unit motor assembly **4-13**
 entrance guide **4-14**
 idler rolls **4-11**
 left shaft assembly **4-10**
 locations **5-1**
 parts catalog **7-2**
 pinch roller **4-18**
 rear cover **4-6**
 removal **4-2**
 right shaft assembly **4-9**
 sensor (bridge unit media entrance) **4-16**
 sensor (bridge unit media exit) **4-17**
 sensor (bridge unit top cover interlock) **4-15**
 top cover assembly **4-7**
 transport belts **4-12**

bridge unit top cover assembly
 parts catalog **7-3**

buffer diverter gate **4-92**

buffer diverter gate solenoid **4-103**

buffer pinch guide assembly **4-96**

buffer roll assembly **4-94**

C

cables

locations **5-7**
 parts catalog **7-28, 7-30, 7-31**

carriage lift belt left **4-30**

carriage lift belt right **4-32**

clamp paddle **4-76**

compiler unit

parts catalog **7-18**

covers

bridge unit rear cover **4-6**

bridge unit top cover **4-7**

bridge unit top cover assembly **7-3**

finisher **7-6**

finisher front door assembly **4-27**

left lower cover **4-28**

left upper cover **4-29**

parts catalog **7-8**

rear lower cover **4-23**

rear upper cover **4-24**

right eject cover **4-21**

right lower LVPS cover **4-22**

top cover **4-19**

upper media bin front cover **4-25**

D

diagnostics

exit **3-3**

diagnostics mode

accessing **3-1**

available tests **3-1**

drive motors

bridge unit **5-1**

buffer/transport **4-115**

entrance/paddle **4-100**

exit **4-113**

E

eject unit

parts catalog **7-18**

electronics

parts catalog **7-26**

entrance drive

parts catalog **7-22**

error code messages **2-3**

error codes

280.00 sensor (bridge unit media entrance) on jam **2-11**

280.01 sensor (bridge unit media entrance) static jam A
2-12

280.02 sensor (bridge unit media entrance) static jam B
2-13

281.00 sensor (bridge unit media exit) on jam A **2-14**

281.01 sensor (bridge unit media exit) on jam B **2-15**

281.02 sensor (bridge unit media exit) on jam C **2-17**

281.03 sensor (bridge unit media exit) static jam **2-18**

282.00 sensor (finisher media entrance) on jam **2-19**

282.01 sensor (finisher media entrance) static jam **2-21**

283.00 sensor (finisher buffer path) on jam A **2-22**

283.01 sensor (finisher buffer path) on jam B **2-24**

283.02 sensor (buffer path) static jam A **2-26**

283.03 sensor (buffer path) static jam B **2-27**

283.04 sensor (buffer path) static jam C **2-28**

284.00 sensor (lower media exit) off jam A **2-28**

284.01 sensor (lower media exit) on jam A **2-30**

284.02 sensor (lower media exit) on jam B **2-32**

284.03 sensor (lower media exit) on jam C **2-34**

284.04 sensor (lower media exit) off jam B **2-36**

284.05 sensor (lower media exit) static jam **2-37**

285.00 finisher eject set jam **2-37**

286.00 sensor (compiler media present) static jam **2-38**

287.00 sensor (upper media exit) on jam A **2-40**

287.01 sensor (upper media exit) off jam A **2-41**

287.02 sensor (upper media exit) on jam B **2-42**

287.03 sensor (upper media exit) on jam C **2-44**

287.04 sensor (upper media exit) off jam B **2-45**

287.05 sensor (upper media exit) static jam A **2-46**
 287.06 sensor (upper media exit) static jam B **2-47**
 287.07 sensor (upper media exit) static jam C **2-48**
 288.00 sensor (diverter gate) on jam **2-49**
 288.01 sensor (diverter gate) static jam (to top bin) A
2-51
 288.02 sensor (diverter gate) static jam (to top bin) B
2-52
 288.03 sensor (diverter gate) static jam (to top bin) C
2-53
 288.04 sensor (diverter gate) static jam (to stacker bin) A
2-54
 288.05 sensor (diverter gate) static jam (to stacker bin) B
2-55
 288.06 sensor (diverter gate) static jam (to stacker bin) C
2-56
 980.02 finisher communication failure **2-56**
 981.00 stacker bin fail **2-57**
 981.01 stacker bin upper limit failure **2-59**
 981.02 stacker bin lower limit failure **2-60**
 982.00 sensor (front tamper HP) on failure **2-62**
 982.01 sensor (front tamper HP) off failure **2-63**
 983.00 sensor (rear tamper HP) on failure **2-64**
 983.01 sensor (rear tamper HP) off failure **2-65**
 984.00 sensor (punch unit HP) on failure **2-66**
 984.01 sensor (punch unit HP) off failure **2-67**
 985.00 sensor (punch carriage shift HP) on failure **2-68**
 985.01 sensor (punch carriage shift HP) off failure **2-69**
 986.00 sensor (media eject clamp HP) on failure **2-70**
 986.01 sensor (media eject clamp HP) off failure **2-71**
 987.00 sensor (media eject shaft HP) on failure **2-72**
 988.00 sensor (punch unit side reg) on failure **2-75**
 988.01 sensor (media eject shaft HP) off failure **2-74**
 988.01 sensor (punch unit side reg) off failure **2-76**
 989.00 stapler unit failure **2-78**
 990.00 sensor (stapler carriage HP) on failure **2-78**
 990.01 sensor (stapler carriage HP) off failure **2-79**
 995.00 finisher NVRAM R/W failure **2-80**
 996.00 finisher type failure **2-80**
 999.00 finisher engine/RIP functional failure **2-81**

error messages

bridge unit top cover open **2-81**
 bridge unit top door open **2-83**
 finisher eject cover open **2-83**
 finisher front door open **2-82**
 finisher upper media bin full **2-84**
 no punch waste box **2-85**
 punch waste box full **2-86**
 stacker lower safety failure **2-90**
 stacker media bin full (mix size) **2-86**
 stacker media bin full (no mix) **2-88**
 stacker set over count failure **2-92**
 staple cartridge empty **2-92**

ESD-sensitive parts **4-1****F**

finisher

removal **4-4**finisher controller card assembly **4-118**

FINISHER TESTS

Feed Tests **3-2**Hole Punch Test **3-2**Sensor Test **3-2**

Bin Level

Fin upper bin full **3-3**
 Stacker bin level encod **3-3**
 Stacker bin level1 **3-3**
 Stacker bin level2 **3-3**
 Stacker bin no media **3-3**
 Stacker bin upper limit **3-3**

Cover and Door

Cover F bridge top **3-3**
 Door G fin front **3-3**
 Surface H fin eject **3-3**

Media Path

Bridge media ent **3-3**
 Bridge media exit **3-3**
 Buffer path **3-3**
 Compiler media in **3-3**
 Fin media enter **3-3**
 Fuser exit **3-3**
 Lower media exit **3-3**
 Upper media exit **3-3**

Media Path2

Diverter gate **3-3**
 Eject clamp hp **3-3**
 Front tamper hp **3-3**
 Media eject shaft hp **3-3**
 Rear tamper hp **3-3**

Punch and Staple

Low staple **3-3**
 Punch box set **3-3**
 Punch cam front **3-3**
 Punch carriage shift hp **3-3**
 Punch hole select **3-3**
 Punch side reg1 **3-3**
 Punch side reg2 **3-3**
 Punch unit hp **3-3**
 Punch waste full **3-3**
 Stapler carriage shift hp **3-3**

Staple Test **3-2**

front door

parts catalog **7-8****H**handling ESD-sensitive parts **4-1****I**installation, confirm status **2-2****L**left lower cover **4-28**left upper cover **4-29**

locations

- bridge unit assembly [5-1](#)
- buffer, upper exit, lower exit and drive motors [5-6](#)
- cables [5-7](#)
- diverter and media eject [5-4](#)
- electronic component diagram [5-10](#)
- finisher control card assembly [5-6](#)
- media eject and media compiler [5-5](#)
- punch unit [5-3](#)
- stacker lift and staple [5-2](#)
- low voltage power supply (LVPS)
 - removal [4-119](#)
- lower exit drive
 - parts catalog [7-20](#)
- lower media exit roll assembly [4-82](#)
- lower pinch guide assembly [4-90](#)

M

- media compiler unit assembly [4-69](#)
- media diverter gate [4-91](#)
- media diverter gate solenoid [4-102](#)
- media eject
 - parts catalog [7-16](#)
- media eject clamp motor assembly [4-66](#)
- media eject clutch [4-77](#)
- media eject motor assembly [4-78](#)
- media eject shaft assembly [4-74](#)
- media eject unit assembly
 - removal [4-59](#)
- media entrance pinch guide assembly [4-97](#)
- media entrance roll assembly [4-99](#)
- models [1-1](#)

P

- paddle and roll exit assembly [4-86](#)
- parts catalog
 - bridge unit [7-2](#)
 - bridge unit lower assembly [7-4](#)
 - bridge unit top cover assembly [7-3](#)
 - buffer [7-22](#), [7-24](#)
 - cables [7-28](#), [7-30](#), [7-31](#)
 - covers [7-6](#)
 - covers and front door [7-8](#)
 - eject and compiler unit [7-18](#)
 - electronics [7-26](#)
 - entrance drive [7-22](#)
 - lower exit drive [7-20](#)
 - media eject [7-16](#)
 - punch [7-12](#)
 - stacker bin lift [7-10](#)
 - stapler [7-14](#)
 - transport [7-24](#)
 - upper drive [7-24](#)
- punch unit
 - parts catalog [7-12](#)
 - punch carriage assembly [4-41](#)
 - punch carriage shift motor assembly [4-43](#)
 - punch media stop assembly [4-46](#)
 - punch unit assembly [4-45](#)
 - punch unit motor assembly [4-47](#)

R

- rear upper cover [4-24](#)
- removals
 - belt (buffer/transport) [4-115](#)
 - belt (entrance/paddle) [4-100](#)
 - belt (exit) [4-113](#)
 - bridge unit assembly [4-2](#)
 - bridge unit drive belt [4-8](#)
 - bridge unit drive motor assembly [4-13](#)
 - bridge unit drive pulley [4-8](#)
 - bridge unit entrance guide [4-14](#)
 - bridge unit idler rolls [4-11](#)
 - bridge unit interface card assembly [4-117](#)
 - bridge unit left shaft assembly [4-10](#)
 - bridge unit pinch roller [4-18](#)
 - bridge unit rear cover [4-6](#)
 - bridge unit right shaft assembly [4-9](#)
 - bridge unit top cover assembly [4-7](#)
 - bridge unit transport belts [4-12](#)
 - buffer diverter gate [4-92](#)
 - buffer diverter gate solenoid [4-103](#)
 - buffer roll assembly [4-94](#)
 - carriage lift belt left [4-30](#)
 - carriage lift right [4-32](#)
 - clamp paddle [4-76](#)
 - drive motor (buffer/transport) [4-115](#)
 - drive motor (entrance/paddle) [4-100](#)
 - drive motor (exit) assembly [4-113](#)
 - finisher [4-4](#)
 - finisher controller card assembly [4-118](#)
 - finisher front door assembly [4-27](#)
 - finisher LVPS [4-119](#)
 - left lower cover [4-28](#)
 - left upper cover [4-29](#)
 - lower media exit roll assembly [4-82](#)
 - lower pinch guide assembly [4-90](#)
 - media compiler unit assembly [4-69](#)
 - media diverter gate [4-91](#)
 - media diverter gate solenoid [4-102](#)
 - media eject assembly [4-59](#)
 - media eject clamp motor assembly [4-66](#)
 - media eject clutch [4-77](#)
 - media eject motor assembly [4-78](#)
 - media eject shaft assembly [4-74](#)
 - media entrance pinch guide assembly [4-97](#)
 - media entrance roll assembly [4-99](#)
 - paddle and roll exit assembly [4-86](#)
 - pinch guide assembly [4-96](#)
 - punch carriage assembly [4-41](#)
 - punch carriage shift motor assembly [4-43](#)
 - punch media stop assembly [4-46](#)
 - punch unit assembly [4-45](#)
 - punch unit motor assembly [4-47](#)
 - rear lower cover [4-23](#)
 - rear upper cover [4-24](#)
 - right eject cover [4-21](#)
 - right lower LVPS cover [4-22](#)
 - sensor (bridge unit media entrance) [4-16](#)
 - sensor (bridge unit media exit) [4-17](#)

sensor (bridge unit top cover interlock) **4-15**
 sensor (buffer path) **4-93**
 sensor (compiler media in) **4-73**
 sensor (diverter gate) **4-110**
 sensor (finisher media entrance) **4-98**
 sensor (front tamper HP) **4-72**
 sensor (lower media exit) **4-80**
 sensor (media eject clamp HP) **4-67**
 sensor (media eject shaft HP) **4-79**
 sensor (punch cam front) **4-49**
 sensor (punch carriage shift HP) **4-51**
 sensor (punch hole select) **4-49**
 sensor (punch unit HP) **4-49**
 sensor (punch unit motor encoder) **4-48**
 sensor (punch unit side registration pair) **4-44**
 sensor (punch waste box full) **4-53**
 sensor (punch waste box set) **4-52**
 sensor (rear tamper HP) **4-72**
 sensor (stacker bin level 1) **4-34**
 sensor (stacker bin level 2) **4-34**
 sensor (stacker bin level encoder) **4-35**
 sensor (stacker bin no media) **4-36**
 sensor (stacker bin upper limit) **4-36**
 sensor (stapler carriage HP) **4-58**
 sensor (upper media bin full) **4-108**
 sensor (upper media exit) **4-104**
 stacker bin lift motor assembly **4-38**
 stacker media bin assembly **4-22**
 stapler unit assembly **4-56**
 stapler unit frame **4-54**
 sub paddle **4-63**
 sub paddle drive shaft assembly **4-64**
 switch (eject cover interlock) **4-68**
 switch (finisher front door interlock) **4-26**
 top cover **4-19**
 upper media bin assembly **4-20**
 upper media bin front cover **4-25**
 upper media exit pinch roll assembly **4-105**
 upper media exit roll assembly **4-106**
 upper media transport roll assembly **4-111**
 upper pinch guide assembly **4-109**

S

safety information **xiii**
 safety inspection guide **6-1**
 sensors

bridge unit media entrance **4-16, 5-1**
 bridge unit media exit **4-17, 5-1**
 bridge unit top cover interlock **4-15, 5-1**
 buffer path **4-93**
 compiler media in **4-73**
 diverter gate **4-110**
 finisher media entrance) **4-98**
 front tamper HP **4-72**
 lower media exit **4-80, 5-4**
 media eject clamp HP **4-67, 5-4**
 media eject shaft HP **4-79**
 punch cam front **4-49, 5-3**
 punch carriage shift HP **4-51, 5-3**
 punch hole select **4-49, 5-3**

punch unit HP **4-49, 5-3**
 punch unit motor encoder **4-48**
 punch unit side reg 1 **5-3**
 punch unit side reg 2 **5-3**
 punch unit side registration pair with bracket **4-44**
 punch waste box full **4-53, 5-3**
 punch waste box set **4-52**
 punch waste box set) **5-3**
 rear tamper HP **4-72**
 stacker bin level 1 **4-34, 5-2**
 stacker bin level 2 **4-34, 5-2**
 stacker bin level encoder **4-35**
 stacker bin no media **4-36**
 stacker bin upper limit **4-36, 5-2**
 stapler carriage HP **4-58, 5-2**
 upper media bin full **4-108**
 upper media exit **4-104**
 service checks **2-11**
 service checks, using **2-1**
 stacker unit
 locations **5-2**
 media bin assembly **4-22**
 stacker bin lift motor assembly **4-38**
 staple unit
 locations **5-2**
 parts catalog **7-14**
 stapler carriage motor assembly **5-2**
 stapler unit assembly **4-56**
 stapler unit frame **4-54**
 sub paddle
 removals **4-63**
 sub paddle drive shaft assembly **4-64**
 switches
 eject cover interlock **4-68, 5-4**
 finisher front door interlock **4-26, 5-2**

T

tests
 Bridge media ent **3-3**
 Bridge media exit **3-3**
 Buffer path **3-3**
 Compiler media in **3-3**
 Cover F bridge top **3-3**
 Diverter gate **3-3**
 Door G fin front **3-3**
 Eject clamp hp **3-3**
 Feed Tests **3-2**
 Fin media enter **3-3**
 Fin upper bin full **3-3**
 Front tamper hp **3-3**
 Fuser exit **3-3**
 Hole Punch Test **3-2**
 Low staple **3-3**
 Lower media exit **3-3**
 Media eject shaft hp **3-3**
 Punch box set **3-3**
 Punch cam front **3-3**
 Punch carriage shift hp **3-3**
 Punch hole select **3-3**
 Punch side reg1 **3-3**

- Punch side reg2 **3-3**
- Punch unit hp **3-3**
- Punch waste full **3-3**
- Rear tamper hp **3-3**
- Stacker bin level encod **3-3**
- Stacker bin level1 **3-3**
- Stacker bin level2 **3-3**
- Stacker bin no media **3-3**
- Stacker bin upper limit **3-3**
- Staple Test **3-2**
- Stapler carriage shift hp **3-3**
- Surface H fin eject **3-3**
- Upper media exit **3-3**
- theory
 - compiler unit assembly **3-15**
 - functions of sensor along the media path **3-10**
 - media transport **3-4**
 - power supply and interlock **3-30**
 - punch unit **3-12**
 - stacker media bin **3-26**
 - stapler **3-21**
 - upper media bin **3-25**
- tools required **1-4**
- top cover
 - removal **4-19**

U

- upper media bin assembly **4-20**
- upper media exit pinch roll assembly **4-105**
- upper media exit roll assembly **4-106**
- upper media transport roll assembly **4-111**
- upper pinch guide assembly **4-109**

4024-XXX

Part number index

| P/N | Description | Page |
|---------|--|-----------------|
| 40X0810 | Bridge unit assembly docking screw | 7-2 |
| 40X0811 | Bridge unit assembly | 7-2 |
| 40X0812 | Bridge unit pinch roll kit | 7-3 |
| 40X0813 | Bridge unit top cover assembly | 7-3 |
| 40X0814 | Bridge unit rear cover | 7-5 |
| 40X0815 | Bridge unit drive belt | 7-5 |
| 40X0816 | Bridge unit drive pulley | 7-5 |
| 40X0817 | Bridge unit drive motor | 7-5 |
| 40X0818 | Bridge unit entrance guide kit | 7-5 |
| 40X0819 | 4 mm ball bearing | 7-5 |
| 40X0820 | Transport belts | 7-5 |
| 40X0821 | Idler roll kit | 7-5 |
| 40X0822 | Bridge unit right shaft kit | 7-5 |
| 40X0823 | Bridge unit left shaft assembly | 7-5 |
| 40X0824 | Magnetic catch | 7-5, 7-23, 7-25 |
| 40X0825 | Sensor (bridge unit top cover interlock) | 7-5 |
| 40X0825 | Sensor (compiler media in) | 7-19 |
| 40X0825 | Sensor (media eject shaft HP) | 7-17, 7-19 |
| 40X0826 | Sensor (bridge unit media exit) | 7-5 |
| 40X0827 | Sensor (bridge unit media entrance) | 7-5 |
| 40X0828 | Bridge unit cable assembly | 7-5 |
| 40X0829 | Top cover | 7-7 |
| 40X0830 | Upper media bin vertical cover | 7-7 |
| 40X0831 | Upper media bin assembly | 7-7 |
| 40X0832 | Right eject cover | 7-7 |
| 40X0833 | Stacker media bin | 7-7 |
| 40X0834 | Right lower LVPS cover | 7-7 |
| 40X0835 | Caster | 7-7 |
| 40X0836 | Rear lower cover | 7-7 |
| 40X0837 | Bridge unit hookup cover | 7-7 |
| 40X0838 | Rear upper cover | 7-7 |
| 40X0839 | Upper media bin front cover | 7-9 |
| 40X0840 | Switch (finisher front door interlock) | 7-9 |
| 40X0841 | Finisher front door assembly | 7-9 |
| 40X0842 | Finisher docking latch kit | 7-9 |
| 40X0843 | Finisher docking bracket kit | 7-9 |
| 40X0844 | Left lower cover | 7-9 |
| 40X0845 | Left upper cover | 7-9 |
| 40X0846 | Carriage lift belt kit | 7-11 |
| 40X0847 | Sensor (stacker bin level) | 7-11 |
| 40X0848 | 10 mm ball bearing | 7-11 |
| 40X0849 | Stacker slip clutch pulley kit | 7-11 |
| 40X0850 | Sensor (front tamper HP) | 7-19 |
| 40X0850 | Sensor (punch cam front) | 7-13 |
| 40X0850 | Sensor (punch carriage shift HP) | 7-13 |
| 40X0850 | Sensor (punch hole select) | 7-13 |
| 40X0850 | Sensor (punch unit HP) | 7-13 |
| 40X0850 | Sensor (punch unit motor encoder) | 7-13 |
| 40X0850 | Sensor (rear tamper HP) | 7-19 |
| 40X0850 | Sensor (stacker bin level encoder) | 7-11 |
| 40X0850 | Sensor (stacker bin no media) | 7-11 |
| 40X0850 | Sensor (stacker bin upper limit) | 7-11 |
| 40X0850 | Sensor (stapler carriage HP) | 7-15 |
| 40X0853 | Punch unit cable assembly | 7-13 |

| | | |
|---------|--|------------------------------|
| 40X0854 | Punch carriage shift motor assembly | 7-13 |
| 40X0855 | Punch carriage assembly | 7-13 |
| 40X0856 | Sensor (punch unit side reg) assembly | 7-13 |
| 40X0857 | 2/3 punch unit assembly (this comes assembled) | 7-13 |
| 40X0858 | 2/4 punch unit assembly (this comes assembled) | 7-13 |
| 40X0859 | Punch media stopper assembly | 7-13 |
| 40X0860 | Punch unit motor assembly | 7-13 |
| 40X0861 | Sensor (punch waste box set) | 7-13 |
| 40X0862 | Punch waste box | 7-13 |
| 40X0864 | Sensor (punch waste box full) | 7-13 |
| 40X0865 | Punch waste box set cable assembly | 7-13, 7-30 |
| 40X0866 | Staple cartridge | 7-15 |
| 40X0867 | Stapler unit assembly | 7-15 |
| 40X0868 | Stapler unit cover | 7-15 |
| 40X0869 | Stapler carriage assembly | 7-15 |
| 40X0870 | Stapler unit cable assembly | 7-15, 7-31 |
| 40X0871 | Stapler carriage motor assembly | 7-15 |
| 40X0872 | Stapler carriage rack gear | 7-15 |
| 40X0873 | Media eject unit assembly (this comes assembled) | 7-17 |
| 40X0874 | Sub paddle | 7-17 |
| 40X0875 | Sub paddle drive shaft kit | 7-17 |
| 40X0876 | Media eject clamp motor | 7-17 |
| 40X0877 | Eject clamp lever assembly | 7-17 |
| 40X0878 | 8 mm bushing | 7-17, 7-19 |
| 40X0879 | Sub paddle/entrance drive gear 23T | 7-17, 7-23 |
| 40X0881 | Eject clamp gear kit | 7-17 |
| 40X0882 | Switch (eject cover interlock) | 7-17 |
| 40X0883 | Media compiler unit assembly (this comes assembled) | 7-19 |
| 40X0886 | Media eject shaft assembly | 7-19 |
| 40X0887 | Clamp paddle | 7-19 |
| 40X0888 | 6 mm bushing | 7-17, 7-19, 7-21, 7-23, 7-25 |
| 40X0889 | Media eject shaft gear 39T | 7-19 |
| 40X0890 | Media eject clutch kit | 7-19 |
| 40X0891 | Media eject motor assembly | 7-19 |
| 40X0892 | Sensor (lower media exit) assembly | 7-29 |
| 40X0892 | Sensor (lower media exit) with bracket | 7-21 |
| 40X0893 | Sensor (buffer path) | 7-23 |
| 40X0893 | Sensor (lower media exit) | 7-21 |
| 40X0893 | Sensor (upper media exit) | 7-25 |
| 40X0894 | Static eliminator brush | 7-21 |
| 40X0895 | Lower media exit roll assembly | 7-21 |
| 40X0896 | Main paddle shaft kit | 7-21 |
| 40X0897 | Belt idler pulley | 7-21, 7-23, 7-25 |
| 40X0898 | Lower exit roll pulley kit | 7-21 |
| 40X0899 | Main paddle idler gear kit | 7-21 |
| 40X0900 | Main paddle drive pulley/gear 44/20T | 7-21 |
| 40X0901 | Lower pinch guide assembly (this comes assembled) | 7-23 |
| 40X0902 | Media diverter gate | 7-23 |
| 40X0903 | Buffer diverter gate | 7-23 |
| 40X0904 | Buffer upper guide assembly | 7-23 |
| 40X0905 | Buffer roll assembly | 7-23 |
| 40X0906 | Buffer pinch guide assembly (this comes assembled) | 7-23 |
| 40X0907 | Media entrance pinch guide assembly (this comes assembled) | 7-23 |
| 40X0908 | Sensor (finisher media entrance) | 7-23 |
| 40X0908 | Sensor (upper media bin full) | 7-25 |
| 40X0909 | Media entrance roll assembly | 7-23 |
| 40X0910 | Drive motor (buffer/transport) | 7-25 |
| 40X0910 | Drive motor (entrance/paddle) | 7-23 |
| 40X0910 | Drive motor (exit) | 7-25 |

40X0911 Belt, entrance/paddle, 31.6 cm ----- 7-23

40X0912 Belt tensioner bracket kit ----- 7-25

40X0912 Belt tensioner pulley kit ----- 7-23

40X0913 6 mm ball bearing ----- 7-21, 7-23, 7-25

40X0914 Media entrance roll drive pulley 20T ----- 7-23

40X0915 Buffer roll drive gear 46T ----- 7-23

40X0916 Media diverter solenoid kit ----- 7-23

40X0917 Buffer diverter solenoid kit ----- 7-23

40X0918 Upper media exit pinch roll assembly ----- 7-25

40X0919 Upper media exit roll assembly ----- 7-25

40X0920 Upper pinch guide assembly (this comes assembled) ----- 7-25

40X0921 Sensor (diverter gate) ----- 7-25

40X0922 Diverter gate sensor cable lower assembly ----- 7-25

40X0922 Diverter gate sensor upper cable assembly ----- 7-30

40X0923 Upper media transport roll assembly ----- 7-25

40X0924 Buffer roll drive pulley/gear 53/23T ----- 7-25

40X0925 Upper media transport roll drive pulley 20T ----- 7-25

40X0926 Upper media exit roll drive pulley/gear, 20T/20T ----- 7-25

40X0927 Upper media exit roll drive gear, 20T ----- 7-25

40X0928 Belt (buffer transport), 19.8 cm ----- 7-25

40X0929 Belt (exit) 27.7 cm ----- 7-25

40X0930 Punch waste box full cable assembly ----- 7-13, 7-31

40X0931 Bridge unit interface card assembly ----- 7-27, 7-31

40X0932 Bridge unit connect cable assembly ----- 7-27, 7-31

40X0933 Bridge unit interface card cable assembly ----- 7-27

40X0934 Finisher controller card assembly ----- 7-27

40X0935 AC power cord assembly ----- 7-27

40X0936 Finisher LVPS card assembly ----- 7-27

40X0937 Main sensor cable assembly ----- 7-29

40X0938 Main drive cable assembly ----- 7-31

40X0939 Finisher interface cable assembly ----- 7-31

40X0940 Finisher media entrance sensor cable assembly ----- 7-29

40X0941 Buffer path sensor cable assembly ----- 7-29

40X0942 Upper media sensor exit cable assembly ----- 7-29

40X0943 Upper media bin full sensor cable assembly ----- 7-29

40X0944 Punch main drive cable assembly ----- 7-30

40X0945 Punch main sensor cable assembly ----- 7-30

40X0946 LVPS cable assembly ----- 7-29

40X0947 Interlock switch cable assembly ----- 7-30

40X0950 Diverter gate sensor lower cable assembly ----- 7-30

4024-XXX

4024 Finisher Service Manual

