



## *Service Manual*

Lexmark™ W820 Finisher

---

4025-XXX

- ***Table of Contents***
- ***Start Diagnostics***
- ***Safety and Notices***
- ***Trademarks***
- ***Index***
- ***Manuals Menu***

**LEXMARK™**

Lexmark and Lexmark with diamond design are trademarks of Lexmark International, Inc., registered in the United States and/or other countries.

**Edition: May 2001**

**The following paragraph does not apply to any country where such provisions are inconsistent with local law:**  
LEXMARK INTERNATIONAL, INC. PROVIDES THIS PUBLICATION "AS IS" WITHOUT WARRANTY OF ANY KIND, EITHER EXPRESS OR IMPLIED, INCLUDING, BUT NOT LIMITED TO, THE IMPLIED WARRANTIES OF MERCHANTABILITY OR FITNESS FOR A PARTICULAR PURPOSE. Some states do not allow disclaimer of express or implied warranties in certain transactions; therefore, this statement may not apply to you.

This publication could include technical inaccuracies or typographical errors. Changes are periodically made to the information herein; these changes will be incorporated in later editions. Improvements or changes in the products or the programs described may be made at any time.

Comments may be addressed to Lexmark International, Inc., Department D22A/032-2, 740 West New Circle Road, Lexington, Kentucky 40550, U.S.A or e-mail at [ServiceInfoAndTraining@Lexmark.com](mailto:ServiceInfoAndTraining@Lexmark.com). Lexmark may use or distribute any of the information you supply in any way it believes appropriate without incurring any obligation to you. You can purchase additional copies of publications related to this product by calling 1-800-553-9727. In other countries, contact your point of purchase.

Lexmark and Lexmark with diamond design are trademarks of Lexmark International, Inc., registered in the United States and/or other countries.

PCL is a registered trademark of the Hewlett-Packard Company.

PostScript is a registered trademark of Adobe Systems Incorporated.

Other trademarks are the property of their respective owners.

**© Copyright Lexmark International, Inc. 2001.  
All rights reserved.**

**UNITED STATES GOVERNMENT RESTRICTED RIGHTS**

This software and documentation are provided with RESTRICTED RIGHTS. Use, duplication or disclosure by the Government is subject to restrictions as set forth in subparagraph (c)(1)(ii) of the Rights in Technical Data and Computer

# Contents

<b>Preface</b> .....	ix
<b>Safety Information</b> .....	x
<b>Introduction</b> .....	1-1
<b>Maintenance Approach</b> .....	1-1
<b>Tools Required For Service</b> .....	1-1
<b>Symbols Used in this Manual</b> .....	1-1
<b>Safety Details</b> .....	1-1
Printer Power Supply and Electrical Components .....	1-2
Mechanical Components .....	1-2
Printer Laser Components .....	1-2
Printer Fuser Components .....	1-3
Safety Components .....	1-3
Caution Labels .....	1-3
<b>Principles of Operation</b> .....	1-4
Finisher Power .....	1-4
Finisher Control .....	1-5
Mechanical Drive .....	1-7
Drive for Jogging .....	1-19
Finisher Paper Path .....	1-26
H-Tra Section .....	1-27
Punch Section .....	1-28
Shift Section .....	1-32
Compiler & Jogger Section .....	1-33
Stapler Section .....	1-36
Exit Sections .....	1-37
Paper Stack Sections .....	1-39
Top Tray Exit Sections .....	1-43
<b>Glossary of Terms, Acronyms, and Abbreviations</b> .....	1-44
<b>Diagnostic Information</b> .....	2-1
<b>Start</b> .....	2-1
<b>Operator Panel Messages</b> .....	2-1
Accessing Additional Debug Information for Service Errors .....	2-3
<b>Service Error Code Table</b> .....	2-4

## 4025-Finisher

<b>Attendance Message Table</b> .....	2-5
<b>Service Checks Flowchart</b> .....	2-9
How to Use the Service Checks Flowchart .....	2-9
How to Follow a Service Check .....	2-9
General Notes on Using Service Checks .....	2-10
<b>Service Checks</b> .....	2-11
Attendance Message Service Checks .....	2-12
Service Error Code Service Checks .....	2-29
<b>Diagnostic Aids</b> .....	3-1
Entering Diagnostic Mode .....	3-1
Exiting Diagnostic Mode .....	3-1
Analyzing the Test Print .....	3-1
Using Test Print to Locate a Feed or Paper Transport Problem .....	3-1
<b>Finisher Tests</b> .....	3-2
Staple Test .....	3-2
Finisher Sensor Test .....	3-2
<b>Removal and Replacement Procedures</b> .....	4-1
<b>Notations in the text</b> .....	4-1
Cover, Rear Removal .....	4-2
Spring Tension 80, Sensor and Harness Earth Removal .....	4-3
Belt-Sync Removal .....	4-5
Bracket Assembly Removal .....	4-6
Tray Harness Assembly Removal .....	4-7
Transport Gear Kit Removal .....	4-9
Solenoid Assembly-Gate In Removal .....	4-11
Cover Top H-Tra Assembly Removal .....	4-13
Roll Transport and Aligner Roll Kit Removal .....	4-14
Entrance Roll Removal .....	4-16
Sensor and Sensor Full Removal .....	4-18
Sensors Removal .....	4-20
Shaft Transport Removal .....	4-22
Cover-Jogging Removal .....	4-23
Tray-Lower Removal .....	4-24
Cover-Top, Front and Rear Removal .....	4-25
Cover-Open, Cover-Front and Kit Stud Cover Removal .....	4-26
Switch Cover Front Removal .....	4-28
Latch Assembly and Switch Docking Removal .....	4-29
Kit H-Tra Bracket and Screw Removal .....	4-31
Cover-Rear Removal .....	4-32
Cover-Top Left Removal .....	4-33
Top Center Cover Assembly Removal .....	4-34

## 4025-Finisher

Kit Bracket Assembly and Screw Removal .....	4-35
Frame Post Removal .....	4-36
Cap-End Removal .....	4-38
Caster Assembly Removal .....	4-39
Lever Assembly Removal .....	4-40
Sensor, Input Path Removal .....	4-41
Sensor, Exit Path Removal .....	4-42
Roll Assembly-REGI Removal .....	4-43
Roll Transport Removal .....	4-44
Kit Drive Assembly Removal .....	4-46
Chute Assembly-Inlet Removal .....	4-48
Kit Invert Guide Removal .....	4-49
Kit Buffer Chute Removal .....	4-51
Knob, Regi Roller Removal .....	4-53
Transport Motor Assembly Removal .....	4-54
Puncher Removal .....	4-55
Kit Roll Pinch Removal .....	4-57
Sensor, Path Removal .....	4-58
Guide Assembly-Dust Removal .....	4-59
Bottle Assembly-Dust Removal .....	4-60
Sensor Dust-Assembly Removal .....	4-61
Inner Cover Removal .....	4-62
Sensor Bottle Kit Removal .....	4-64
Kit Motor Jogging Removal .....	4-66
Sensor, Jogger Home Position Removal .....	4-68
Plate-Jogger Removal .....	4-70
Kit Shift Assembly Removal .....	4-71
Knob, Shift Unit Removal .....	4-75
Kit Shift Motor Removal .....	4-76
Motor Assembly-MP2 Removal .....	4-77
Sensor, Exit Path Removal .....	4-79
Compiler Roll and Roll Shaft Removal .....	4-80
Sensor, Exit Roller Open/Close Home Position Removal .....	4-81
Exit Roll Sensor Removal .....	4-82
Kit Gear Front Removal .....	4-83
Motor Removal .....	4-84
Kit Gear Rear Removal .....	4-85
Motor Assembly-MP4 Removal .....	4-87
Staple Stage Assembly, Stack Roll Shaft, No Paper Sensor Stapler Removal	4-88
Stack Arm Assembly, No Paper Sensor Tray Lower Removal .....	4-90
Stapler I Assembly Removal .....	4-92
Stapler II Assembly Removal .....	4-97
Stapler Harness Assembly Removal .....	4-98

## 4025-Finisher

Cartridge Removal .....	4-101
Traverse Motor Assembly Removal .....	4-102
Motor Assembly-Swing Removal .....	4-104
Sensor Assembly Swing Removal .....	4-106
Belt Removal .....	4-110
Cable, Flat Removal .....	4-111
Sensor, Stapler Home Position Traverse Removal .....	4-113
Kit Bearing Removal .....	4-114
Holder Assembly Removal .....	4-116
Blade Assembly Removal .....	4-118
Sensor Tray Height Front Removal .....	4-119
Shaft Assembly ELEV U Removal .....	4-120
Shaft Assembly ELEV L Removal .....	4-121
Drive Assembly-ELEV, Motor Assembly-MD11 Removal .....	4-124
Right Cover Removal .....	4-126
Encoder Assembly Removal .....	4-128
Power Supply Removal .....	4-130
PWB Assembly-Main Removal .....	4-132
Port Harness Assembly Removal .....	4-135
No Paper Sensor Assembly Removal .....	4-136
Face Up Tray Removal .....	4-138
Top Cover Interlock Switch Removal .....	4-139
Gate Solenoid Removal .....	4-140
Full Stack Sensor Assembly Removal .....	4-141
Pinch Roll Removal .....	4-142
Exit Sensor Removal .....	4-143
Exit Assembly Removal .....	4-145
Upper Roll and Roll Transport Removal .....	4-147
Stepping Motor, Upper Tray Removal .....	4-149
Gear Kit Removal .....	4-150

## Connectors .....

5-1

### Location Table .....

5-2

Location Map 1 .....	5-6
Location Map 2 .....	5-7
Location Map 3 .....	5-8
Location Map 4 .....	5-9
Location Map 5 .....	5-10
Location Map 6 .....	5-11
Wiring Diagram Notations .....	5-12
Master Wiring Diagram .....	5-13

## Preventative Maintenance .....

6-1

## Parts Catalog .....

7-1

## 4025-Finisher

How to Use This Parts Catalog .....	7-1
Assembly 1: Top Cover .....	7-2
Assembly 2: Frame Transport Assembly .....	7-4
Assembly 3: .....	7-6
Assembly 4: Docking Parts, Front Cover, Top Tray .....	7-8
Assembly 5: Rear Cover .....	7-10
Assembly 6: Chute 1 .....	7-12
Assembly 7: Chute 2 .....	7-14
Assembly 8: Top Exit .....	7-16
Assembly 9: Frame .....	7-18
Assembly 10: Guide .....	7-20
Assembly 11: Puncher Assembly .....	7-22
Assembly 12: Jogging Assembly .....	7-24
Assembly 13: Shift Assembly .....	7-26
Assembly 14: Stacker Unit .....	7-28
Assembly 15: Stacker Tray .....	7-30
Assembly 16: Stapler Assembly .....	7-32
Assembly 17: Elevator Unit .....	7-34
Assembly 18: Finisher Main PWB, Power Supply .....	7-36
Assembly 19: Harness .....	7-38
<b>Index</b> .....	<b>I-1</b>





---

## Preface

This manual describes the Lexmark™ W820 4025-XXX Finisher and contains maintenance procedures for service personnel only. It is divided into the following chapters:

- 1. General Information** contains a general description of the printer and the maintenance approach used to repair it. Special tools and test equipment are listed in this chapter, as well as general environmental and safety instructions.
- 2. Diagnostic Information** contains an error indicator table, symptom tables, and service checks used to isolate failing field replaceable units (FRUs).
- 3. Diagnostic Aids** contains tests and checks used to locate or repeat symptoms of printer problems.
- 4. Repair Information** provides instructions for making printer adjustments and removing and installing FRUs.
- 5. Connector Locations** uses illustrations to identify the connector locations and test points on the printer.
- 6. Preventive Maintenance** - There are no preventative maintenance procedures for the Lexmark W820 (4025) Finisher.
- 7. Parts Catalog** contains illustrations and part numbers for individual FRUs.

---

## Safety Information

- This product is designed, tested and approved to meet strict global safety standards with the use of specific Lexmark components. The safety features of some parts may not always be obvious. Lexmark is not responsible for the use of other replacement parts.
- The maintenance information for this product has been prepared for use by a professional service person and is not intended to be used by others.
- There may be an increased risk of electric shock and personal injury during disassembly and servicing of this product. Professional service personnel should understand this and take necessary precautions.

---

## Consignes de Sécurité

- Ce produit a été conçu, testé et approuvé pour respecter les normes strictes de sécurité globale lors de l'utilisation de composants Lexmark spécifiques. Les caractéristiques de sécurité de certains éléments ne sont pas toujours évidentes. Lexmark ne peut être tenu responsable de l'utilisation d'autres pièces de rechange.
- Les consignes d'entretien et de réparation de ce produit s'adressent uniquement à un personnel de maintenance qualifié.
- Le démontage et l'entretien de ce produit pouvant présenter certains risques électriques, le personnel d'entretien qualifié devra prendre toutes les précautions nécessaires.

---

## Norme di sicurezza

- Il prodotto è stato progettato, testato e approvato in conformità a severi standard di sicurezza e per l'utilizzo con componenti Lexmark specifici. Le caratteristiche di sicurezza di alcune parti non sempre sono di immediata comprensione. Lexmark non è responsabile per l'utilizzo di parti di ricambio di altri produttori.
- Le informazioni riguardanti la manutenzione di questo prodotto sono indirizzate soltanto al personale di assistenza autorizzato.
- Durante lo smontaggio e la manutenzione di questo prodotto, il rischio di subire scosse elettriche e danni alla persona è più elevato. Il personale di assistenza autorizzato, deve, quindi, adottare le precauzioni necessarie.

---

## Sicherheitshinweise

- Dieses Produkt und die zugehörigen Komponenten wurden entworfen und getestet, um beim Einsatz die weltweit gültigen Sicherheitsanforderungen zu erfüllen. Die sicherheitsrelevanten Funktionen der Bauteile und Optionen sind nicht immer offensichtlich. Sofern Teile eingesetzt werden, die nicht von Lexmark sind, wird von Lexmark keinerlei Verantwortung oder Haftung für dieses Produkt übernommen.
- Die Wartungsinformationen für dieses Produkt sind ausschließlich für die Verwendung durch einen Wartungsfachmann bestimmt.
- Während des Auseinandernehmens und der Wartung des Geräts besteht ein zusätzliches Risiko eines elektrischen Schlags und körperlicher Verletzung. Das zuständige Fachpersonal sollte entsprechende Vorsichtsmaßnahmen treffen.
- 

---

## Pautas de Seguridad

- Este producto se ha diseñado, verificado y aprobado para cumplir los más estrictos estándares de seguridad global usando los componentes específicos de Lexmark. Puede que las características de seguridad de algunas piezas no sean siempre evidentes. Lexmark no se hace responsable del uso de otras piezas de recambio.
- La información sobre el mantenimiento de este producto está dirigida exclusivamente al personal cualificado de mantenimiento.
- Existe mayor riesgo de descarga eléctrica y de daños personales durante el desmontaje y la reparación de la máquina. El personal cualificado debe ser consciente de este peligro y tomar las precauciones necesarias.

---

## Informações de Segurança

- Este produto foi concebido, testado e aprovado para satisfazer os padrões globais de segurança na utilização de componentes específicos da Lexmark. As funções de segurança de alguns dos componentes podem não ser sempre óbvias. A Lexmark não é responsável pela utilização de outros componentes de substituição.
- As informações de segurança relativas a este produto destinam-se a profissionais destes serviços e não devem ser utilizadas por outras pessoas.
- Risco de choques eléctricos e ferimentos graves durante a desmontagem e manutenção deste produto. Os profissionais destes serviços devem estar avisados deste facto e tomar os cuidados necessários.

## Informació de Seguretat

- Aquest producte està dissenyat, comprovat i aprovat per tal d'acomplir les estrictes normes de seguretat globals amb la utilització de components específics de Lexmark. Les característiques de seguretat d'algunes peces pot ser que no sempre siguin òbvies. Lexmark no es responsabilitza de l'ús d'altres peces de recanvi.
- La informació pel manteniment d'aquest producte està orientada exclusivament a professionals i no està destinada a ningú que no ho sigui.
- El risc de xoc elèctric i de danys personals pot augmentar durant el procés de desmuntatge i de servei d'aquest producte. El personal professional ha d'estar-ne assabentat i prendre les mesures convenients.

### 안전 사항

- 본 제품에 관한 유지 보수 설명서는 전문 서비스 기술자 용으로 작성된 것이므로 비 전문가가 사용할 수 없습니다.
- 본제품을 해체하거나 정비할 경우 전기적인 충격을 받거나 상처를 입을 위험이 커집니다. 전문 서비스 기술자는 이 사실을 숙지하고 필요한 예방 조치를 취하도록 하십시오.
- 일부 부품의 안전성은 항상 보장되지 않습니다. 따라서, 교체 부품은 원래 부품과 같거나 동등한 특성을 가진 제품을 사용해야 합니다.

### 安全资讯

- 本产品的维护资讯仅供专业服务人员使用，而非针对一般使用者。
- 本产品在拆卸、维修的时候，遭受电击或人员受伤的危险性会增高，专业服务人员对这点必须有所了解，并采取必要的预防措施。
- 有些零件的安全功能可能不明显。因此，所替换零件的性能一定要与原有的零件一致。

---

# 1. Introduction

---

## Maintenance Approach

The diagnostic information in this manual leads you to the correct field replaceable unit (FRU) or part for the Finisher. Use the error code table, attendance message table, error code service checks and attendance message service checks to determine the corrective action necessary to repair the failing option. After you complete the repair, perform tests as needed to verify the repair.

---

## Tools Required For Service

The removal and replacement procedures described in this manual require the following tools and equipment:

- Magnetic tip Phillips screwdrivers, large and small
- Flat-blade screwdrivers
- Analog volt ohmmeter (a digital volt ohmmeter may also be used)

---

## Symbols Used in this Manual

Various symbols are used throughout this manual to either provide additional information on a specific topic or to warn of possible danger that might be present during a procedure or action. Be aware of all symbols when they are used, and always read NOTE, CAUTION, and WARNING messages.

**Note:** A NOTE may indicate an operating or maintenance procedure, practice, or condition that is necessary to efficiently accomplish a task. A NOTE may also provide additional information related to a specific subject or add a comment on the results achieved through a previous action.

**WARNING:** A WARNING indicates an operating or maintenance procedure, practice, or condition that, if not strictly observed, could result in damage to, or destruction of, equipment.

**CAUTION:** A CAUTION indicates an operating or maintenance procedure, practice, or condition that, if not strictly observed, could result in injury.

---

## Safety Details

Follow all safety instructions to prevent accidents while servicing the printer and attached options. Always be aware of the potential dangers that are present when you are working with electrical or mechanical equipment.

## Printer Power Supply and Electrical Components

Before starting any service procedure, switch off the printer power and unplug the power cord from the wall outlet. If you must service the options with the printer power applied, be aware of the potential for electrical shock.

**CAUTION:** Do not touch any electrical component unless you are instructed to do so by a service procedure.

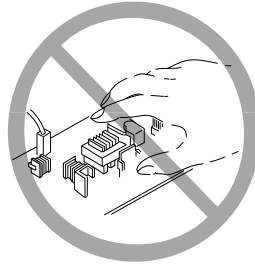

## Mechanical Components

Manually rotate drive assemblies to inspect sprockets and gears.

**CAUTION:** Do not try to manually rotate or manually stop the drive assemblies while any printer or option motor is running.

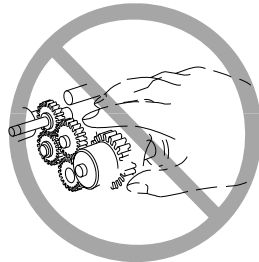

## Printer Laser Components

**CAUTION:** The printer generates a laser beam as part of the printing process. The laser beam is a concentrated narrow beam of light that produces extreme heat at its focal point. The laser beam in this printer is invisible. Although you cannot see the beam, it can still cause severe damage. Direct eye exposure to the laser beam may cause eye injury or blindness.

## 4025-Finisher

To avoid permanent eye damage, follow these directions:

- Before starting any service procedure, switch off the printer power and unplug the power cord from the AC wall outlet.
- Do not disassemble the printer Printhead Assembly or any laser component that displays a Laser Warning sticker.
- Use caution when you are working around the printer Printhead Assembly or when you are performing laser related troubleshooting or repair procedures.
- Never place a mirror or a reflective tool or object in the laser beam path.
- Do not disassemble the printer in such a way that the laser beam can exit the print engine during a print cycle.

## Printer Fuser Components

**CAUTION:** This printer uses heat to fuse the toner image to a sheet paper. The printer Fuser Assembly is very hot. Switch off printer power and wait at least 45 minutes for the fuser to cool before you attempt to service the printer Fuser Assembly or adjacent components.

## Safety Components

Make sure covers and panel are in place and that all interlock switches are all functioning correctly after you have completed a printer or option service call. If you bypass, or cheat, an interlock switch during a service call, use extreme caution when working on or around the printer or options.

## Caution Labels

Throughout the equipment, warning labels are displayed on potentially dangerous components. When you service the printer and options, check to make sure that all caution labels are in place.

Most importantly, read and obey all posted caution labels.

## Principles of Operation

### Finisher Power

The Base Engine supplies 120VAC to the Finisher, and the Finisher Power Supply converts it into 24VDC and 5VDC that are necessary for the Finisher to function, and sends these voltages to it.

The printer AC power cord plugs into a grounded AC electrical outlet. The cord carries AC line voltage to the Noise Filter PWB. The Noise Filter smooths the AC voltage and sends it to the Main Power Switch. Switching on the Main Power Switch applies AC voltage to the Finisher Power Supply. The Finisher Power Supply converts the 120 V ac to regulated +5 V dc and +24 V dc voltages. The Finisher Power Supply sends these voltages to the Finisher PWB. The Finisher PWB uses these voltages to run internal logic, sensors, clutches, and motors within the Finisher.

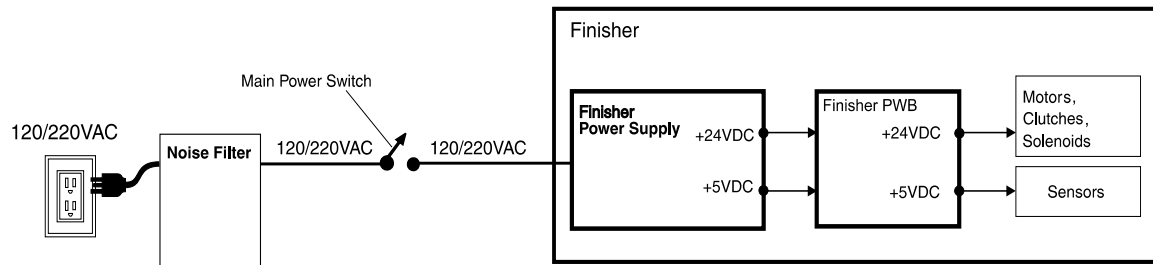



## Finisher Control

Finisher Control describes the printer resources that monitor and control the actions and operations of the printer and the Finisher; from paper feed to error detection.

The center of Finisher control is the *Finisher PWB*. The MCU PWB provides the logic and information processing that is necessary for the printer to function, and the *Finisher PWB* provides the logic and information processing that is necessary for the Finisher to function. Every electrical component within the Finisher is connected to the *Finisher PWB*. Sensors in the Finisher send paper feed status information to the *Finisher PWB*. The *Finisher PWB* processes that information, shares it with the MCU PWB, and compares it to timing tables stored in ROM. Acting on the results of the processing, the *Finisher PWB* sends commands to the various Finisher components; turning on a motor.

### Finisher Control Components

- The Finisher PWB controls all Finisher functions, executes commands sent from the MCU PWB, and sends information back to the MCU PWB. All Finisher components are connected directly to the Finisher PWB.
- The Finisher Power Supply takes filtered AC voltage and converts it into regulated +24 V dc and +5 V dc.
- The Punch Dust Full Sensor detects that the Punch Dust Box becomes full with punched dust.
- The Punch Dust Box Sensor detects the presence of the Punch Dust Box.
- The Exit Roller Interlock Switch detects whether the Exit Roller: Upper is open excessively, and cuts off the power supply if excessively open.
- The Front Cover Interlock Switch detects whether the Front Cover is open. It cuts off the power supply to each electrical component when the Front Cover is open.
- The Docking Interlock Switch detects whether the Finisher is docked to the printer correctly.
- The Top Cover Interlock Switch detects whether the Top Cover is open. It cuts off the power supply to each electrical component when the Top Cover is open.

# 4025-Finisher

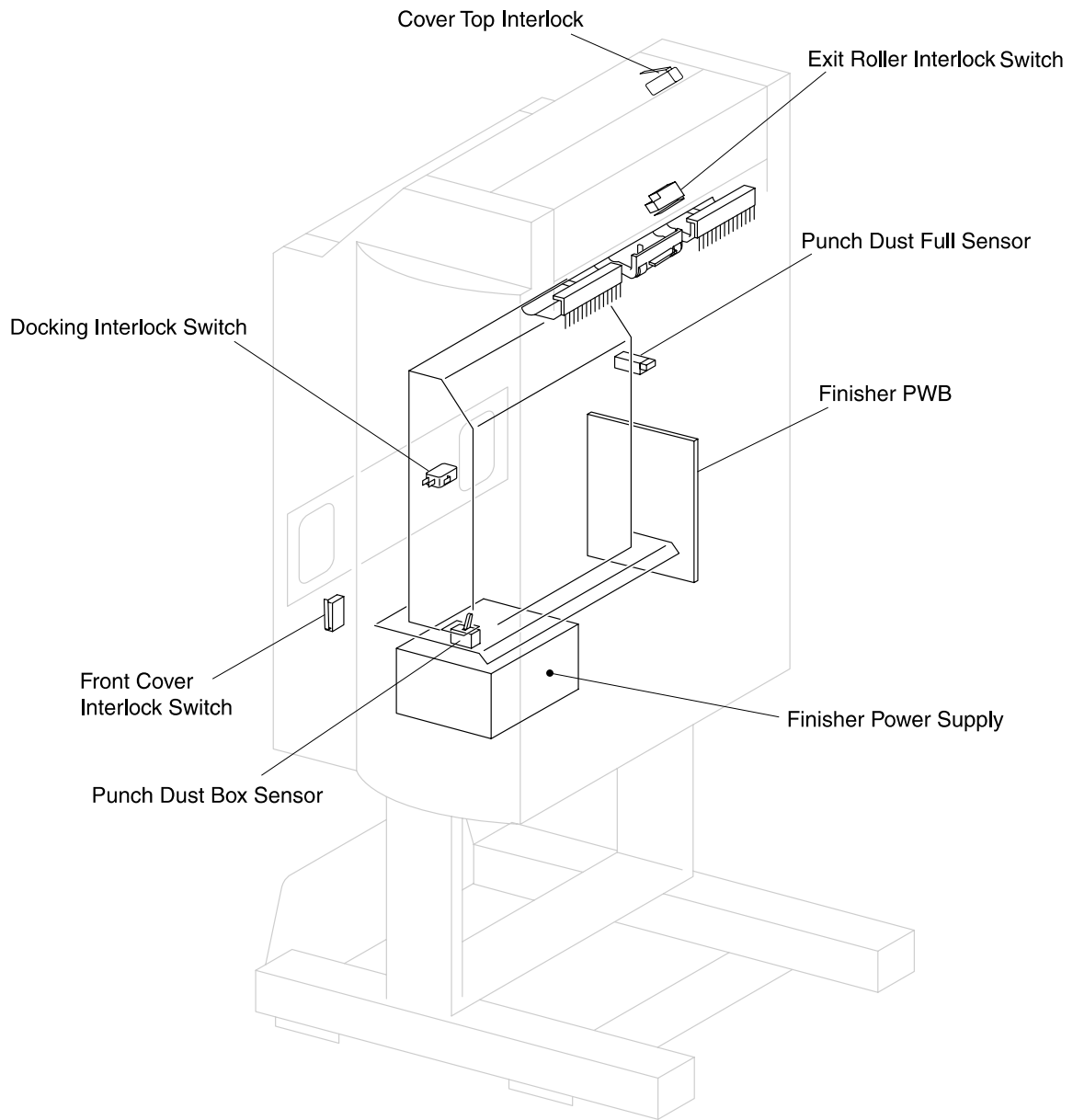

## Mechanical Drive

Mechanical Drive describes both the rotation of the Motor and the action of the gears, belts, and clutches that are used to transmit and control motor drive to the various components throughout the Finisher. The primary purpose of Mechanical Drive within the Finisher is to provide the mechanical energy needed to drive.

### Drive for H-Tra

The driving force generated by the Main Feed Motor in the Finisher is transmitted from the H-Tra Gear Idle R to the Pulley One-way 1,2,3 via the Belt-SYNC, to rotate the H-Tra Feed Roller 1,2,3.

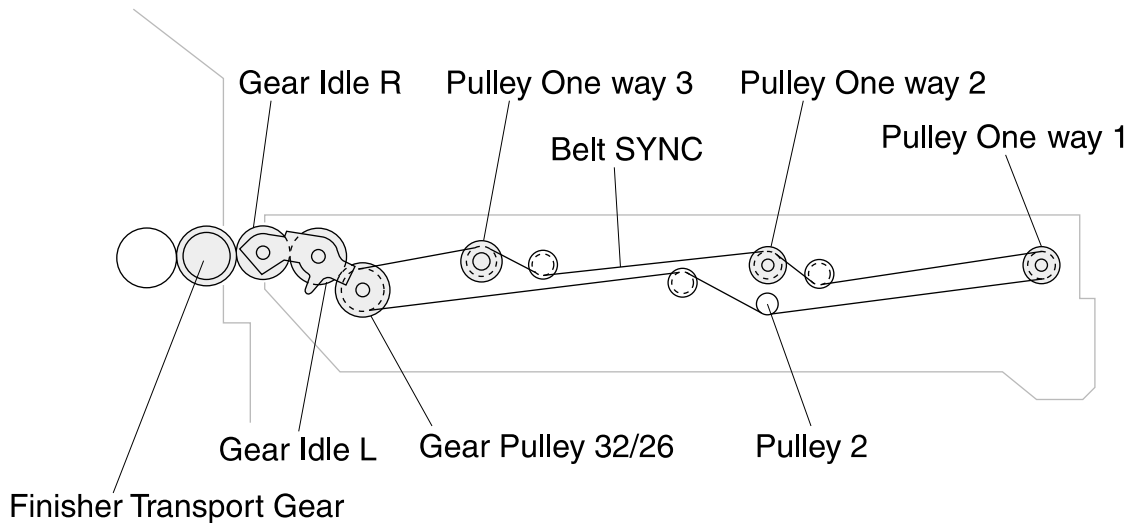

### Mechanical Drive H-Tra Components

- The Gear Idle R transmits the driving force transmitted from the Finisher to the Gear Idle L.
- The Gear Idle L transmits the driving force transmitted from the Gear Idle R to the Gear Pulley 32/26.
- The Gear Pulley 32/26 transmits the driving force transmitted from the Gear Idle L to the Pulley One way 1,2,3 via the Belt SYNC.
- The Belt SYNC transmits the driving force transmitted from the Gear Pulley 32/26 to the Pulley One way 1,2,3.
- The Pulley One way 1 transmits the driving force transmitted from the Belt SYNC to the H-Tra Feed Roller 1.
- The Pulley One way 2 transmits the driving force transmitted from the Belt SYNC to the H-Tra Feed Roller 2.
- The Pulley One way 3 transmits the driving force transmitted from the Belt SYNC to the H-Tra Feed Roller 3.

## Drive for Fin Input Roller & Regi Roller

The rotation of the Main Feed Motor drives the Main Drive Belt to transmit a driving force to the Main Drive Gear. The rotation of the Main Drive Gear transmits a driving force to the Feed Gear 1.

In the transmission of a driving force to the Regi Roller, the rotation of the Feed Gear 1 drives the Timing Belt 1, and the driving force from the Timing Belt 1 rotates the Regi Roll Gear to rotate the Regi Roller.

In the transmission of a driving force to the Fin Input Roller and the H-Tra Drive, the rotation of the Feed Gear 1 transmits a driving force to the Drive Gear 2. And the rotation of the Drive Gear 2 is transmitted to the Drive Gear 3, and driving the Timing Belt 2 transmits a driving force to the Transport Gear, and then the Transport Gear transmits a driving force to the entire H-Tra Drive. Drive Gear 3 rotates the Drive Gear 4. Then, the rotation of the Drive Gear 4 transmits a driving force to the Fin Input Gear, to rotate the Fin Input Roller. The Drive Gear 4 also transmits a driving force to the Transport Gear, and then the Transport Gear transmits a driving force to the entire H-Tra Drive.

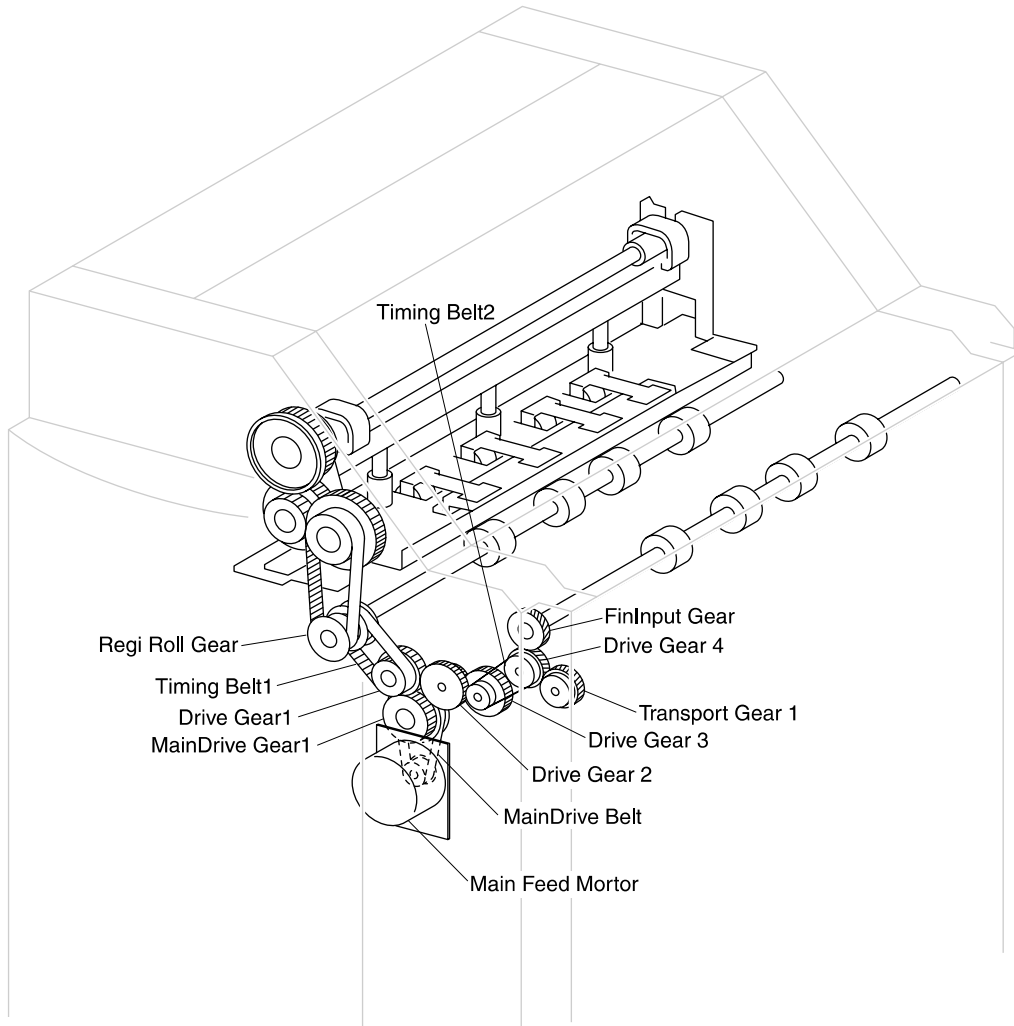

## Mechanical Drive Fin Input Roller & Regi Roller Components

- The Main Feed Motor supplies a driving force to the Punch Clutch, Fin input Roller and Regi Roller. It also supplies a driving force to the entire H-Tra via the Transport Gear 1.
- The Main Drive Gear transmits the driving force transmitted from the Main Feed Motor to the Feed Gear 1 via the Main Drive Belt.
- The Feed Gear 1 transmits the driving force transmitted from the Main Drive Gear to the Timing Belt 1. It also transmits the driving force to the Drive Gear 2.
- The Drive Gear 2 transmits the driving force transmitted from the Feed Gear 1 to the Timing Belt 1.
- The Drive Gear 3 transmits the driving force transmitted from the Drive Gear 2 to the Timing Belt 2.
- The Drive Gear 4 transmits the driving force transmitted from the Timing Belt 2 to the Fin Input Gear and Transport Gear 1.
- The Fin Input Gear rotates the Fin Input Roller.
- The Regi Roll Gear rotates the Regi Roller. It also transmits the driving force transmitted from the Timing Belt 1 to the Punch Drive Belt.
- The Transport Gear 1 transmits the driving force transmitted from the Drive Gear 4 to the H-Tra Gear Idle R.
- The Timing Belt 1 transmits the driving force transmitted from the Feed Gear 1 to the Regi Roll Gear.
- The Timing Belt 2 transmits the driving force transmitted from the Drive Gear 3 to the Fin Input Roll Gear.

## Drive for Punch Unit

The rotation of the Main Feed Motor drives the Main Drive Belt to transmit a driving force to the Main Drive Gear. The rotation of the Main Drive Gear transmits a driving force to the Feed Gear 1. The rotation of the Feed Gear 1 drives the Timing Belt 1, and driving the Timing Belt 1 rotates the Regi Roll Gear. The driving force from the Regi Roll Gear is transmitted to the Punch Gear 1 via the Punch Drive Belt. Then, the rotation of the Punch Gear 1 transmits a driving force to the Punch Clutch via the Punch Gear 2. The rotation of the Punch Clutch moves up and down the Punch Shaft in the Punch Unit to perform the punching operation. The counterclockwise rotation of the Punch Motor moves up the Punch Shaft, while the clockwise rotation moves down the shaft.

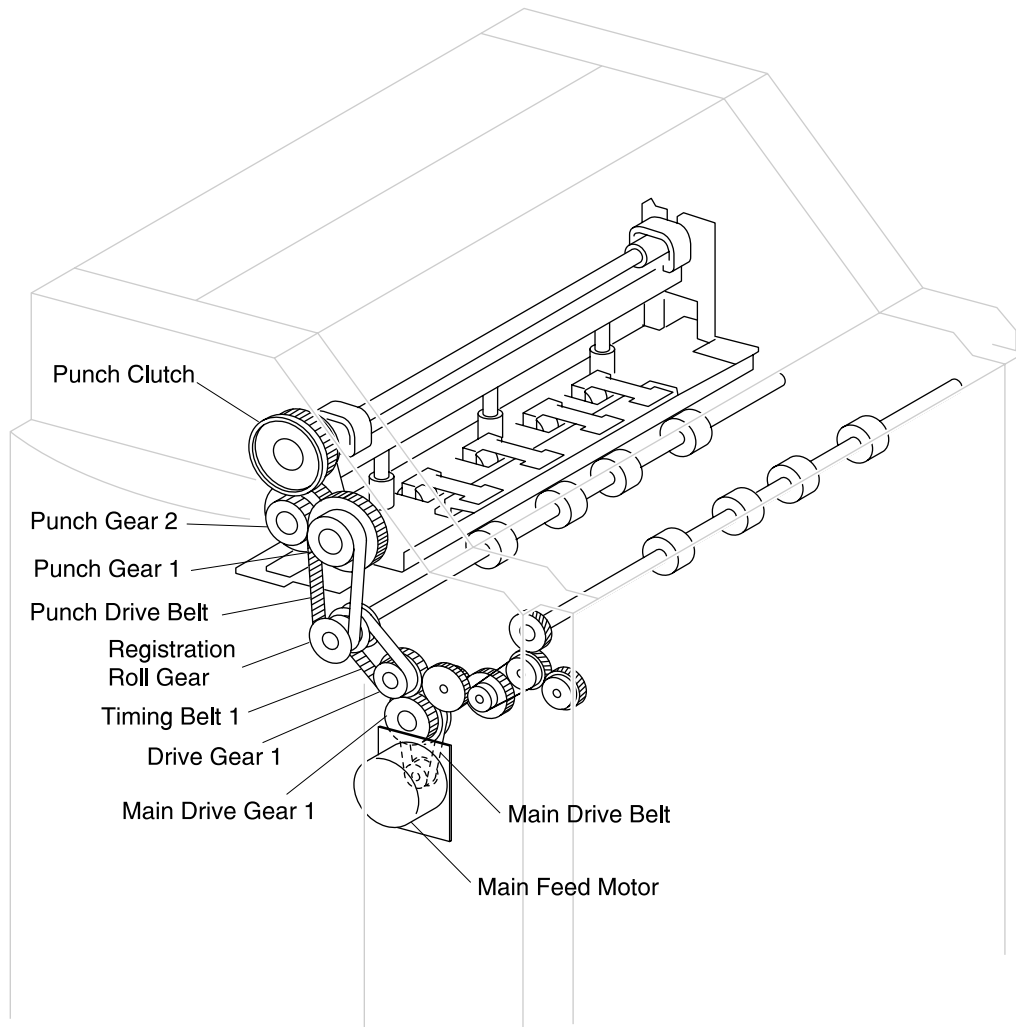

## Mechanical Drive Punch Unit Components

- The Main Feed Motor supplies a driving force to the Punch Clutch, Fin input Roller and Regi Roller. It also transmits a driving force to the entire H-Tra via the Transport Gear 1.
- The Punch Clutch transmits the driving force transmitted from the Punch Gear2 to the Punch Shaft on the Punch Unit.
- The Regi Roll Gear rotates the Regi Roller. It also transmits the driving force transmitted from the Timing Belt 1 to the Punch Drive Belt.
- The Punch Gear 1 transmits the driving force transmitted from the Punch Drive Belt to the Punch Gear 2.
- The Punch Gear 2 transmits the driving force transmitted from the Punch Drive 1 to the Punch Clutch.
- The Punch Drive Belt transmits the driving force transmitted from the Regi Roll Gear to the Punch Gear 1.

## Drive for Shift Roller Unit & Main Paddle & Sub Paddle

- The driving force transmitted by the Compiler Tray Feed Motor

In the transmission of a driving force to the Shift Roller, the rotation of the Compiler Tray Feed Motor transmits a driving force to the Shift Roll Gear 1, to rotate the Shift Roller. At the same time, the rotation of the Shift Roll Gear 1 rotates the Shift Roll Gear 2 via the Shift Roller. The rotation of the Shift Roll Gear 2 transmits a driving force to the Shift Transmit Pulley. The Paddle Drive Belt on the Shift Transmit Pulley transmits a driving force to the Sub Paddle Pulley, and the rotation of the Sub Transmit Pulley rotates the Sub Paddle.

In the shift of the Shift Roller Unit, the clockwise or counterclockwise rotation of the Shift Motor moves up or down the unit.

In the transmission of a driving force to the Main Paddle, the rotation of the Compiler Tray Feed Motor transmits a driving force to the Main Paddle Gear via the Transmit Gear. Then, the rotation of the Main Paddle Gear rotates the Main Paddle.

- The driving force transmitted by the Shift Handle

The Shift Handle is manually rotated to rotate the Shift Handle Gear. The rotation of the Shift Handle Gear transmits a driving force to the Shift Roll Gear, to rotate the Shift Roller. And the rotation of the Shift Roll Gear also transmits a driving force to the Shift Transmit Pulley. The Paddle Drive Belt on the Shift Transmit Pulley transmits a driving force to the Sub Paddle Pulley, and the rotation of the Sub Transmit Pulley rotates the Sub Paddle.

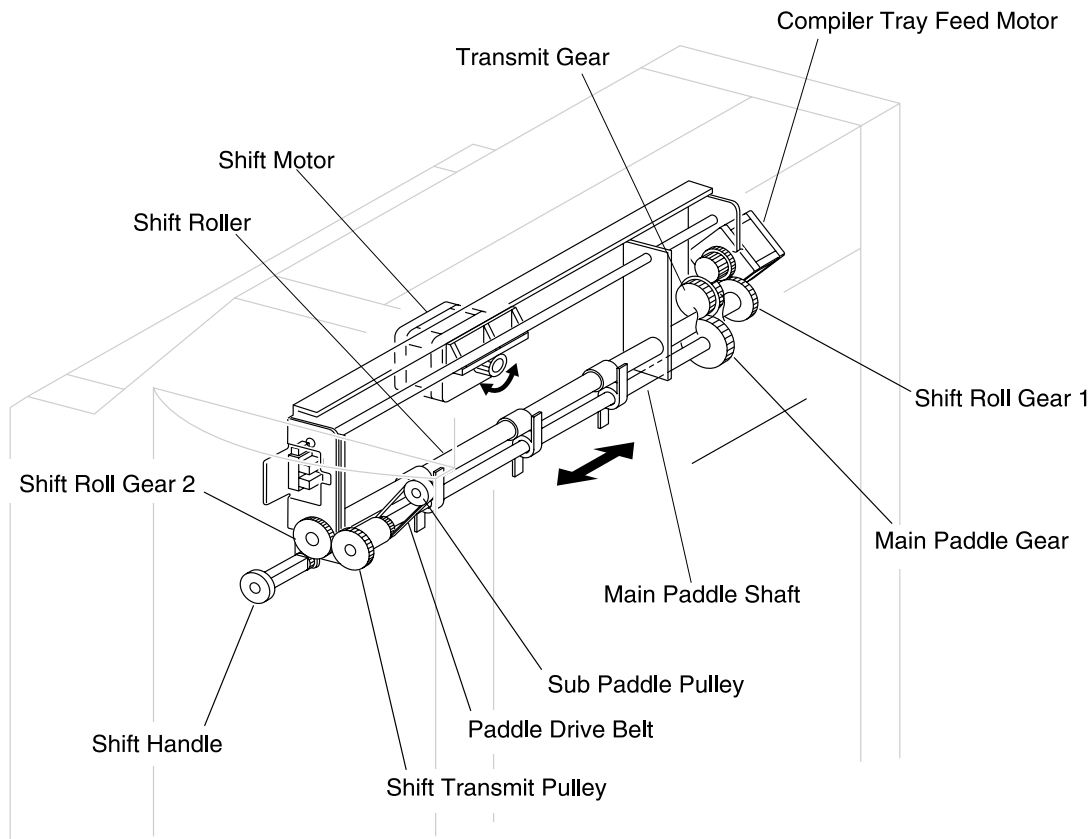



## 4025-Finisher

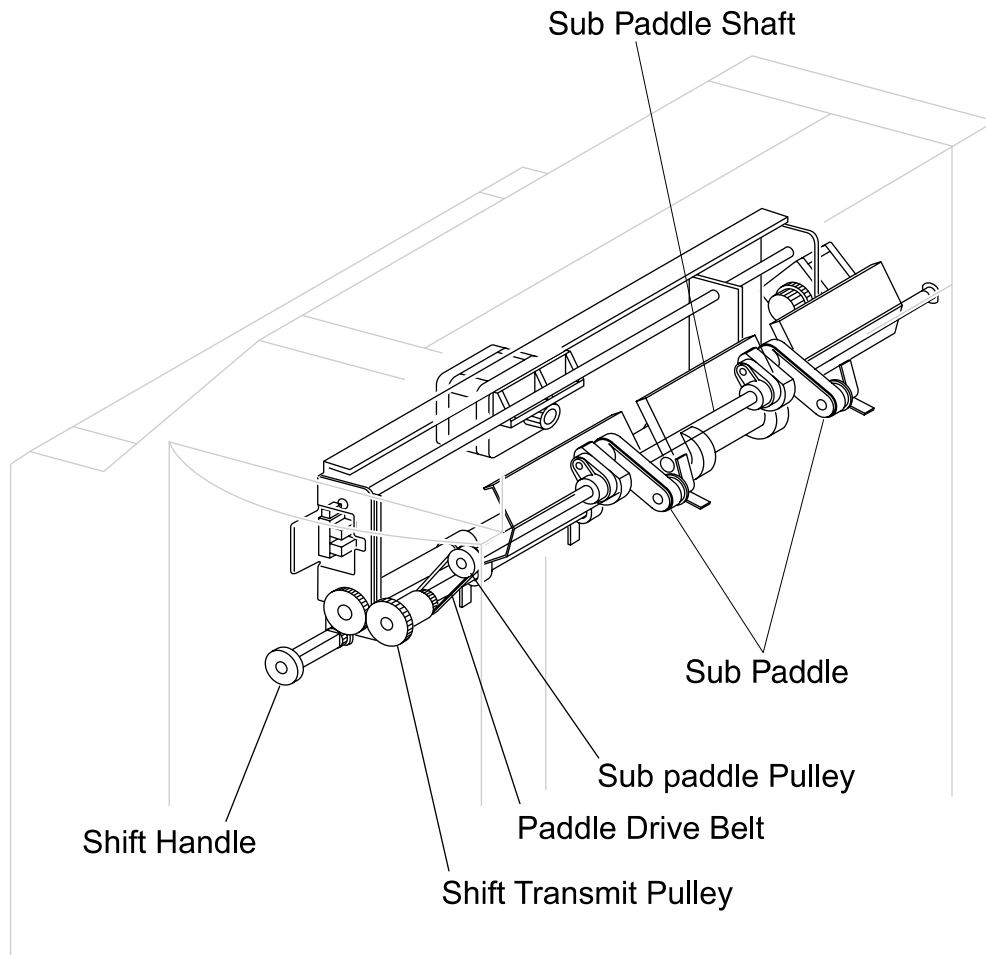

## **Mechanical Shift Roller Unit & Main Paddle & Sub Paddle Components**

- The Compiler Tray Feed Motor supplies a driving force to the Shift Roller and Main Paddle.
- The Shift Motor supplies a driving force to the Shift Roller to perform the shifting job.
- The Shift Roll Gear 1 transmits the driving force transmitted from the Compiler Tray Feed Motor to the Shift Roller, and the Shift Roller rotates.
- The Transmit Gear transmits the driving force transmitted from the Compiler Tray Feed Motor to the Main Paddle Gear, and the Main Paddle Gear rotates.
- The Main Paddle Gear rotates the Main Paddle.
- The Shift Roll Gear 2 transmits the driving force generated from the rotation of the Shift Roller to the Shift Transmit Gear. And it also transmits the driving force transmitted from the Shift Handle Gear to the Shift Transmit Pulley, when rotating the Shift Handle manually.
- The Shift Transmit Pulley transmits the driving force transmitted from the Shift Roll Gear 2 to the Paddle Drive Belt via the Shift Transmit Pulley.
- The Paddle Drive Belt transmits the driving force generated from the rotation of the Shift Transmit Pulley to the Sub Paddle Pulley.
- Driving the Sub Paddle Pulley rotates the Shift Transmit Pulley, and the Sub Paddle is rotated.

## Drive for Exit 1: Exit Pinch Roll Guide

The rotation of the Exit Roller Open/Close Motor transmits a driving force to the Open/Close Gear 1 and Open/Close Gear 2. Then, the rotation of the Open/Close Gear 2 moves up the Sector Gear. By means of the convex portion on the side surface of the Sector Gear, the lever at the end of the Exit Pinch Roll Shaft is raised, and the Exit Pinch Roll Guide is opened upward.

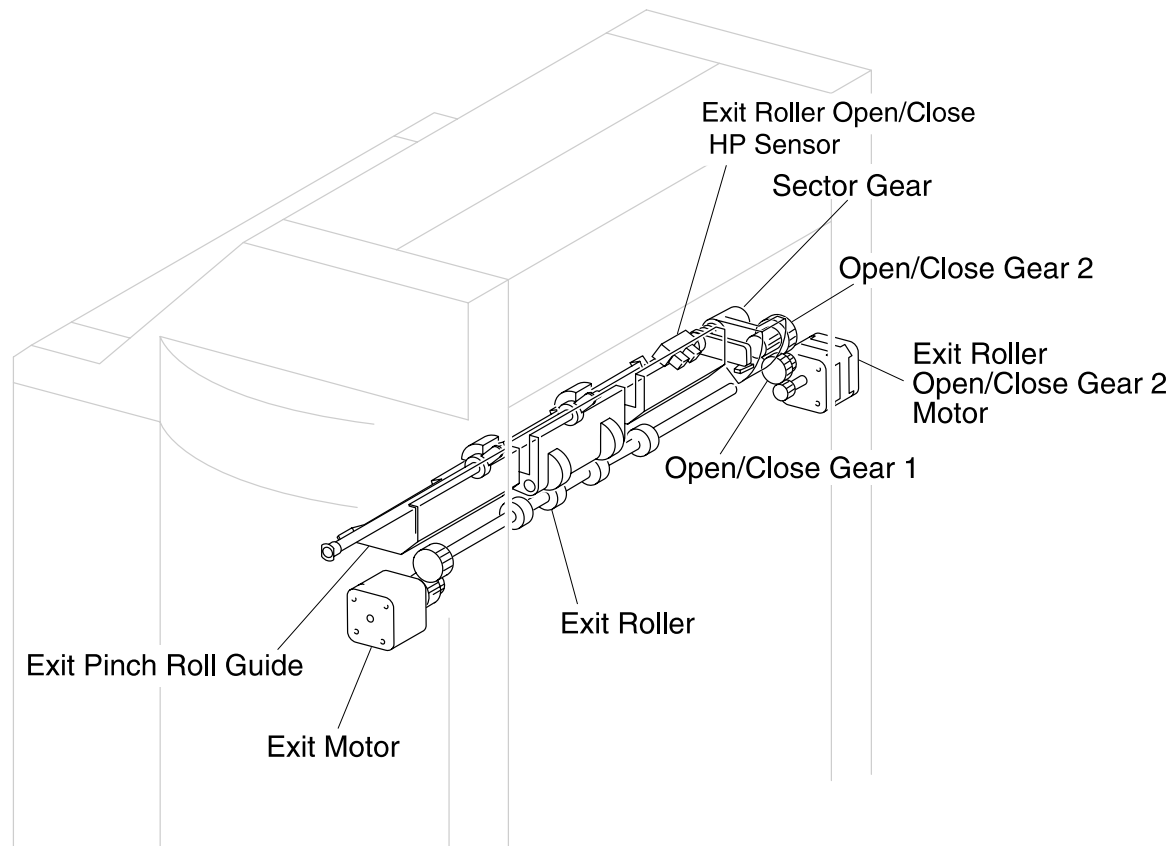

### Mechanical Drive Exit 1: Exit Pinch Roll Guide Components

- The Exit Roller Open/Close Motor transmits a driving force to the Sector Gear via each gear, to open/close the Exit Pinch Roll Guide.
- The Open/Close Gear 1 transmits the driving force transmitted from the Exit Roller Open/Close Motor to the Open/Close Gear 2.
- The Open/Close Gear 2 transmits the driving force transmitted from the Open/Close Gear 1 to the Sector Gear.
- Receiving the driving force transmitted from the Open/Close Gear 2, the Sector Gear moves up and down the Exit Pinch Roll Guide by means of the convex portion on the side surface of the Sector Gear.

## Drive for Exit 2: Exit Roller & Compiler Tray

- The driving force transmitted to the Exit Roller

The rotation of the Exit Motor transmits a driving force to the Exit Roll Gear. The rotation of the Exit Roll Gear rotates the Exit Roller. Also, the Exit Motor rotates counterclockwise when drawing the paper into the Compiler Tray.

- The driving force transmitted to the Compiler Move Tray

The counterclockwise rotation of the Exit Motor rotates the Exit Roller via the Exit Roll Gear. The Compiler Drive Pulley on the Exit Roller transmits the driving force generated from the rotation of the Exit Roller to the Move Tray Belt. The Move Tray Belt transmits a driving force to the Com Drive Gear 1 on the Compiler Drive Shaft, to rotate the Compiler Drive Shaft. The rotation of the Compiler Drive Shaft transmits a driving force to the Com Transmit Gear via the Com Drive Gear 2, to rotate the Compiler Transmit Shaft. Then, the rotation of the Compiler Transmit Shaft transmits a driving force to the gear on the back of the Compiler Move Tray, via the Com Transmit Gear on the shaft. The Compiler Move Tray is pushed out toward the paper delivery direction by the transmitted driving force.

# 4025-Finisher

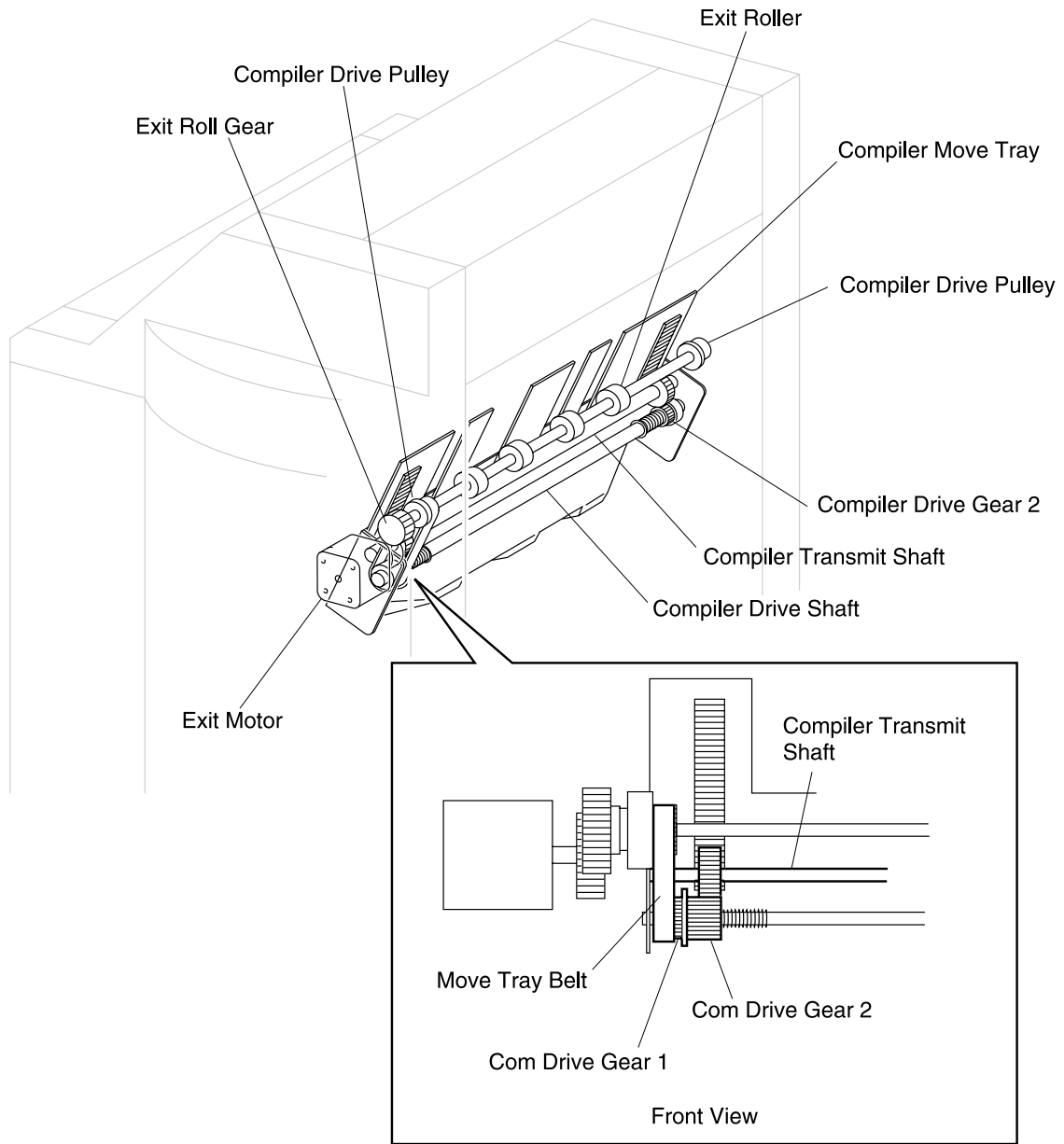

## **Mechanical Drive Exit 2: Exit Roller & Compiler Move Tray Components**

- The Exit Motor supplies a driving force to the Exit Roller.
- The Exit Roll Gear transmits a driving force transmitted from the Exit Motor to the Exit Roller, to rotate the Exit Roller.
- The Compiler Drive Pulley rotates by the rotation of the Exit Roller to transmit a driving force to the Move Tray Belt.
- The Move Tray Belt transmits the driving force transmitted from the Compiler Drive Pulley to the Com Drive Gear 1.
- The Com Drive Gear 1 rotates the Compiler Drive Shaft.
- The rotation of the Compiler Drive Shaft transmits a driving force to the Com Transmit Gear via the Com Drive Gear 2.

The Com Transmit Gear transmits the driving force transmitted from the Compiler Drive Shaft to the gear on the back of the Compiler Move Tray, to move the Compiler Move Tray forward or backward.

## Drive for Jogging

The Jogging Motor transmits a driving force to the Jogging Gear. The rotation of the Jogger Gear rotates the Spiral Shaft. Then, the Jogger Flap moves on the Spiral Shaft.

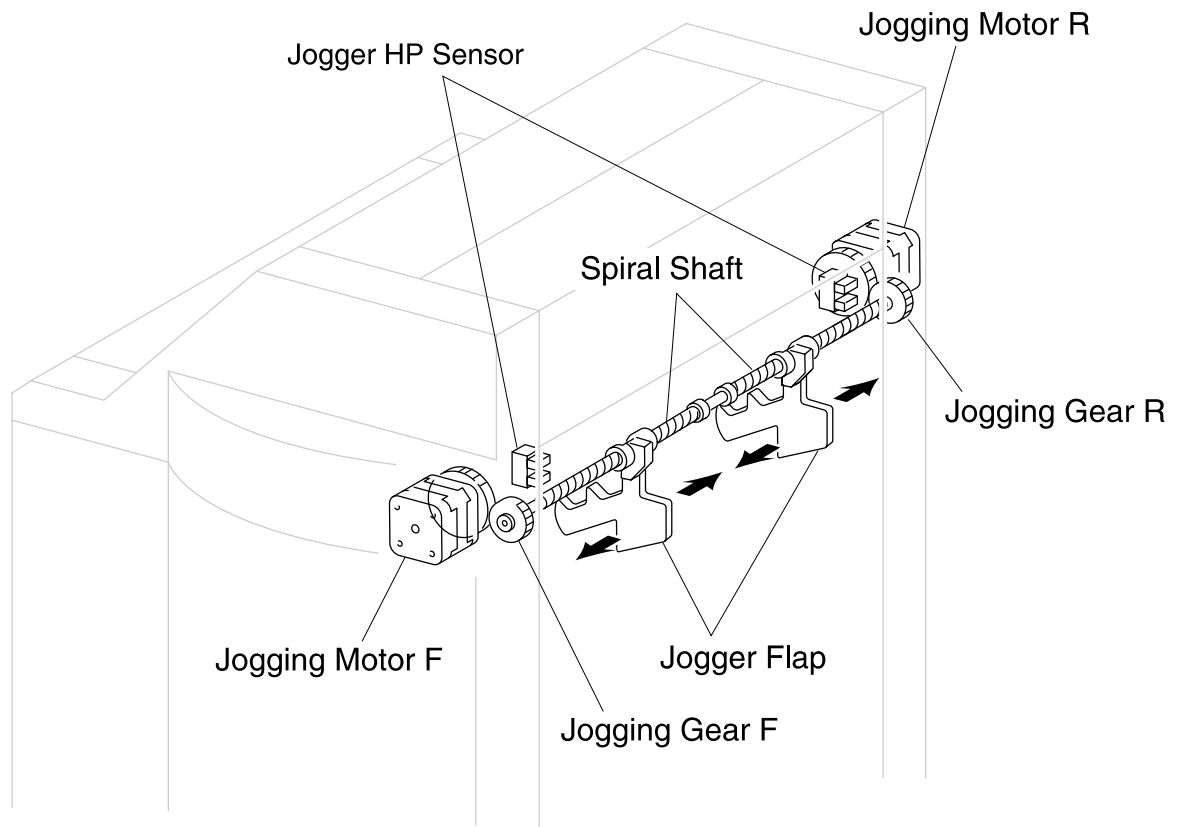

### Mechanical Drive Jogging Components

- The Jogging Motor F/R supplies a driving force to the Jogging Gear, to move the Jogger Flap.
- The Jogging Gear F/R transmits the driving force transmitted from the Jogging Motor to the gear on the Spiral Shaft, to rotate the Spiral Shaft.
- The Spiral Shaft F/R moves the Jogger Flap by the rotation of the Spiral Shaft.
- The Jogger Flap aligns the paper in the Compiler.
- The Jogger HP Sensor detects the Jogger home position to confirm the Jogger Flap position.

## Drive for Staple

The Stapler Traverse Motor transmits a driving force to the Stapler Drive Pulley. The rotation of the Stapler Drive Pulley drives the Stapler Timing Belt to move the Stapler Unit to the left and right.

The Stapler Swing Motor transmits a driving force to the Stapler Swing Gear 1. The rotation of the Stapler Swing Gear 1 transmits a driving force to the Stapler Swing Gear 2. Then, the Stapler Swing Gear 2 transmits a driving force to the Sector Gear in the Stapler Unit, and the Sector Gear swings the Stapler Unit toward +45° or -45° direction.



# 4025-Finisher

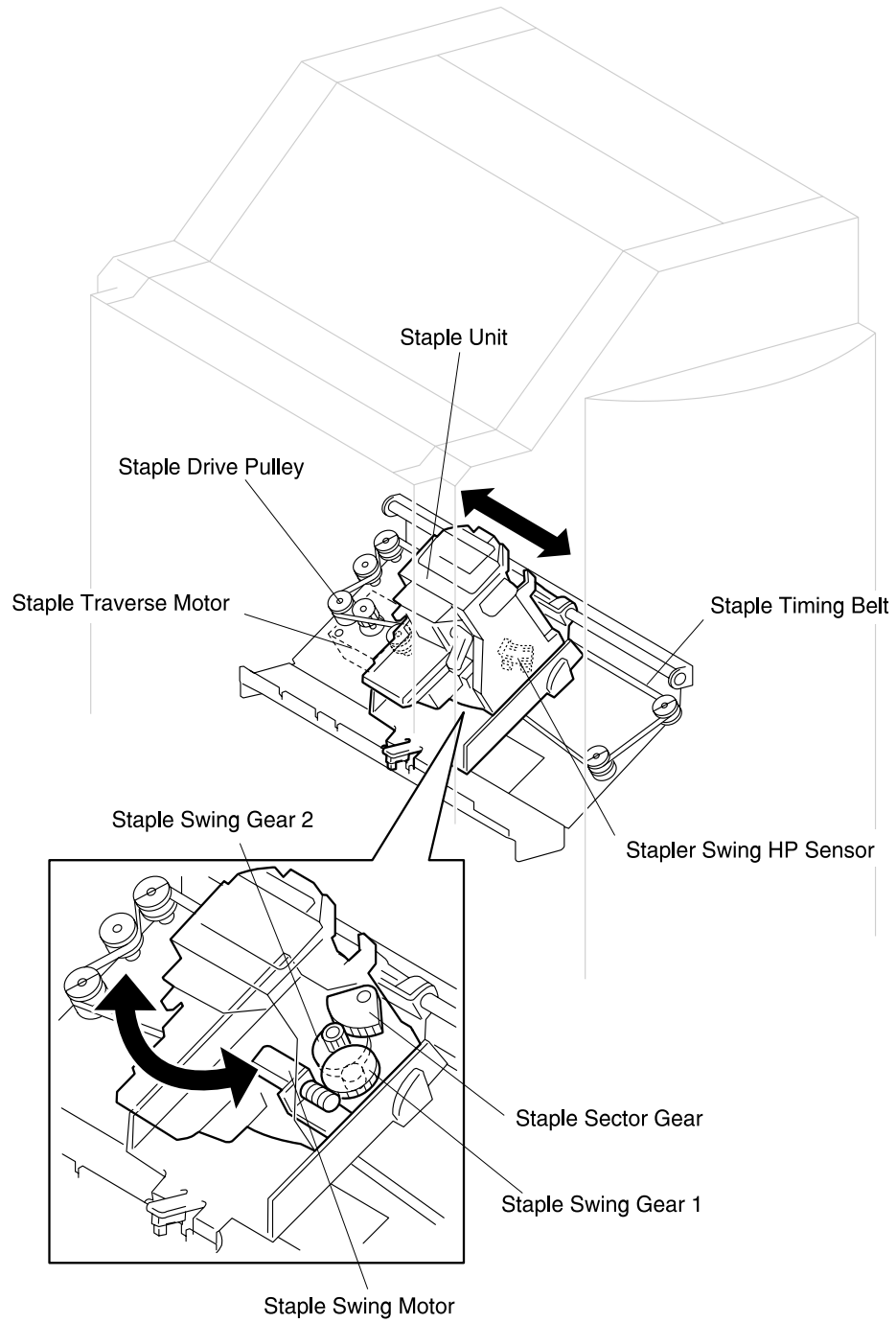

## Mechanical Drive Stapler Components

- The Stapler Traverse Motor supplies a driving force to the Stapler Drive Pulley.
- The Stapler Drive Pulley transmits the driving force from the Stapler Traverse Motor to the Stapler Timing Belt.
- The Stapler Timing Belt moves the Stapler Unit to the left and right by the belt drive.
- The Stapler Swing Motor supplies a driving force to the Stapler Swing Gear 1.
- The Stapler Swing Motor transmits the driving force transmitted from the Stapler Swing Motor to the Stapler Swing Gear 2.
- The Stapler Swing Gear 2 transmits the driving force transmitted from the Stapler Swing Gear 1 to the Sector Gear in the Stapler Unit, to swing the unit.
- The Stapler Swing HP Sensor detects the Stapler tilt angle when the Stapler Unit performs the stapling.

## Drive for Stacker Tray

The rotation of the worm gear in the Lift Up Motor supplies a driving force to each gear on the Elevator Drive Unit via the Lift Up Gear 1. Then, the rotation of the Lift Up Gear 2 transmits a driving force to the Elevator Drive Gear. The driving force transmitted to the Elevator Drive Gear rotates the Elevator Shaft. The rotation of the Elevator shaft transmits a driving force to the Elevator Belt to elevate the Stacker Tray.

The rotation of the worm gear in the Lift Up Motor transmits a driving force to the Lift Up Gear 3 via each gear on the Elevator Drive Unit. The rotation of the Lift Up Gear 3 rotates the Liner Encoder.

# 4025-Finisher

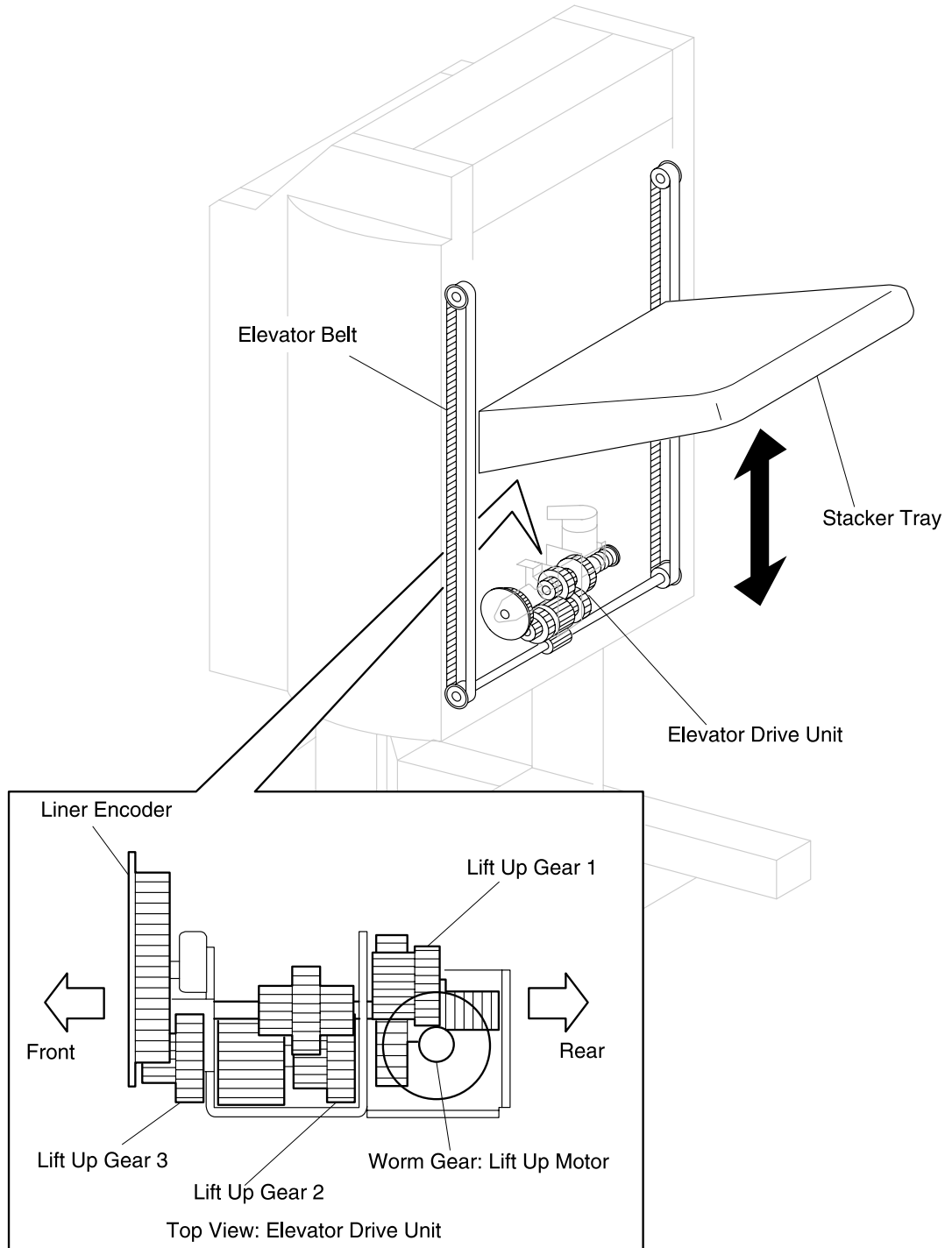

## Mechanical Stacker Tray Components

- The Lift Up Motor supplies a driving force to the Elevator Shaft via each gear on the Elevator Drive Unit.
- The Elevator Drive Unit supplies the driving force generated by the Lift Up Motor to the Elevator Drive Gear and Liner Encoder.
- The Elevator Drive Gear rotates the Elevator Shaft by the driving force transmitted from the Elevator Drive Unit.
- The Elevator Belt elevates the Stacker Tray by the rotation of the Elevator Shaft.
- The Lift Up Gear 3 rotates the Liner Encoder by the driving force transmitted from the Lift Up Motor.

## Drive for Top Tray Exit

The rotation of the Exit Top Motor transmits a driving force to the Exit Top Belt. Driving the Exit Top Belt transmits a driving force to the Exit Top Gear (Lower, Middle and Upper), to rotate them. Then, the rotation of each gear rotates the Exit Top Roller.

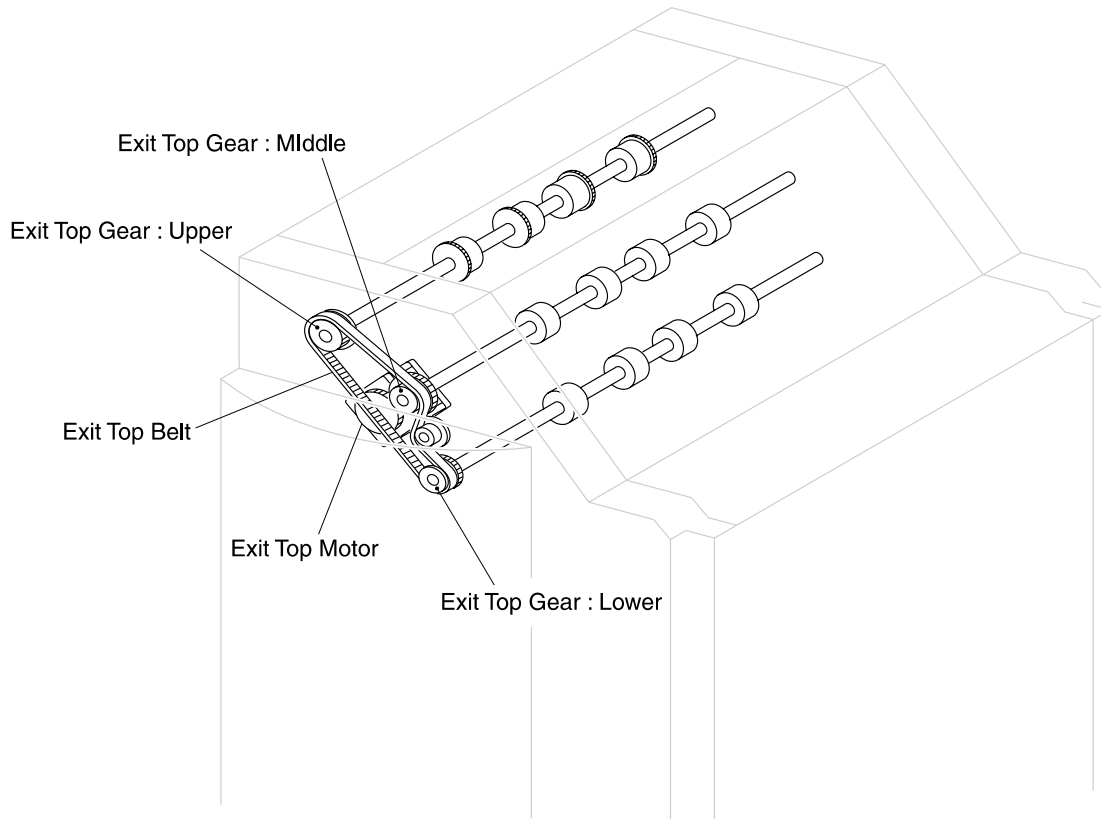

## Mechanical Top Tray Exit Components

- The Exit Top Motor supplies a driving force to the Exit Top Gear.
- The Exit Top Gear: Upper rotates the Exit Top Roller: Upper by the driving force transmitted from the Exit Top Belt.
- The Exit Top Gear: Middle transmits the driving force transmitted from the Exit Top Motor to the Exit Top Belt. And it also rotates the Exit Top Roller: Middle by the rotation of the Exit Top Gear.
- The Exit Top Gear: Lower rotates the Exit Top Roller: Lower by the driving force transmitted from the Exit Top Belt.
- The Exit Top Belt transmits the driving force transmitted from the Exit Top Motor to each gear.

## Finisher Paper Path

Main mechanisms in the Finisher are described by paper transfer path, as follows:

- H-Tra: Mechanism to transfer paper from the printer to the Finisher.
- Punch section: Mechanism to punch paper.
- Shift section: Mechanism to shift paper toward the front or rear.
- Compile & Jogging section: Mechanism to draw the paper into the Compiler Tray by the paddle and to jog a bundle of paper in a jogging job (only when stapling is performed).
- Stapler section: Mechanism to compile a bundle of paper on the Compiler Tray (only when stapling is performed).
- Exit section: Mechanism to deliver paper, or to transfer paper to the Compiler Tray.
- Paper Stack section: Mechanism to stack up the delivered paper on the tray and to move up or down the Stacker Tray according to the stacking volume.
- Top Tray Exit section: Mechanism to deliver paper to the Top Tray.

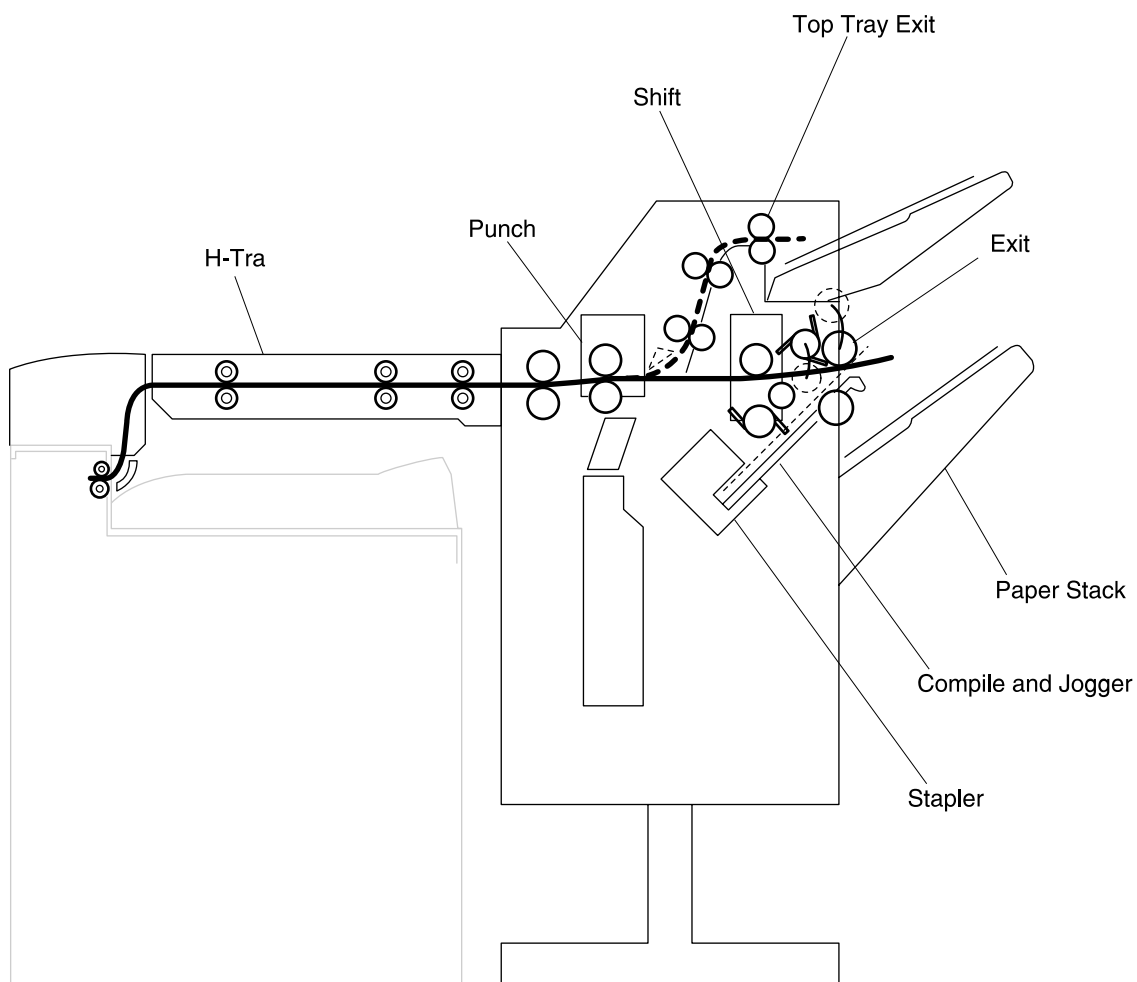

## H-Tra Section

The paper delivered from the printer passes the H-Tra Gate and is transferred into the H-Tra. Then, the rotation of the H-Tra Feed Roller in the H-Tra transfers the paper toward the Finisher. Also, during the paper transfer, the rotation of the H-Tra Feed Roller shifts the paper to the front side, to adjust the skew and registered position.

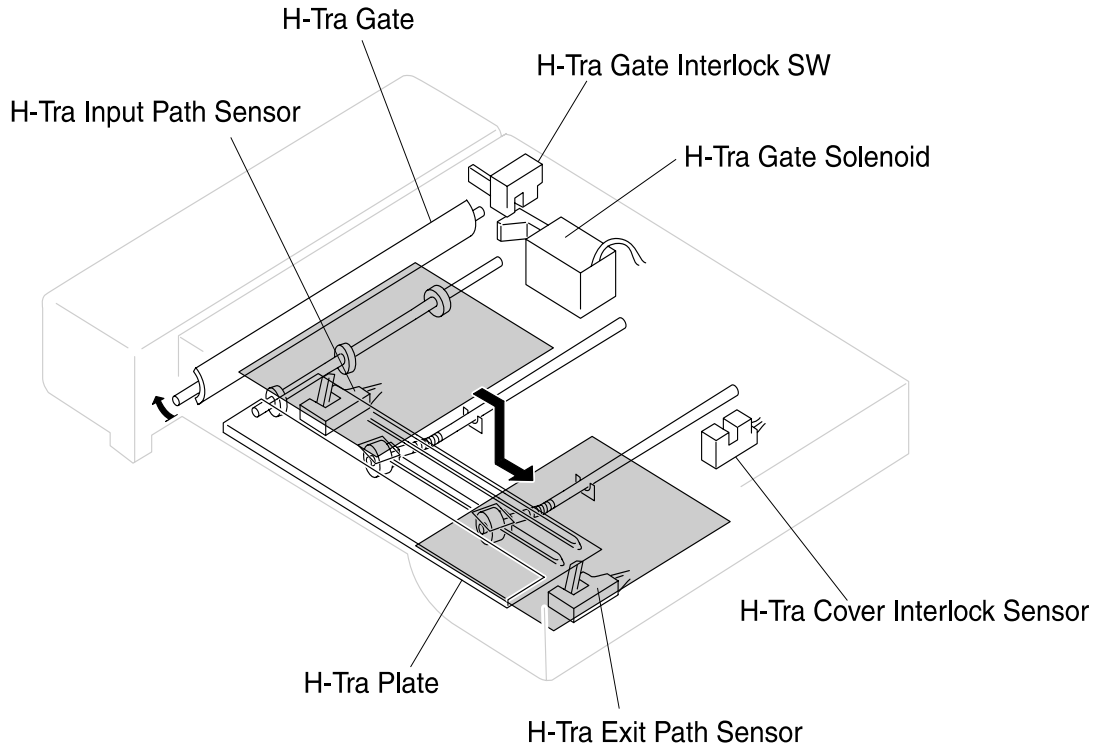

## H-Tra Components

- The H-Tra Gate Solenoid changes over the H-Tra Gate.
- Changed over by the H-Tra Gate Solenoid, the H-Tra Gate transfers the paper toward the H-Tra.
- Gate opens: When paper is transferred to the H-Tra.
- Gate closes: When paper is delivered on the printer Face Down Tray (in Duplex mode)
- The H-Tra Input Path Sensor monitors paper being transferred from the printer into the H-Tra.
- The H-Tra Exit Path Sensor monitors paper passing the H-Tra paper exit.
- The H-Tra Feed Roller feeds the paper transferred into the H-Tra toward the Finisher.
- The H-Tra Gate Interlock SW detects H-Tra Gate excessive open state, and cuts off the power supply.
- The H-Tra Cover Interlock Sensor detects H-Tra Cover open state.
- The printer FD Tray Full Sensor detects when the printer Face Down Tray located at the bottom of H-Tra is full with paper.

## Punch Section

- Route for paper delivery to the Stacker Tray

The paper transferred from the H-Tra to the Finisher passes the Fin Input Path Sensor in the Finisher, and it is transferred toward the Shift Roller by the rotation of the Fin Input Roller and Regi Roller. After the trailing edge of the paper passes the Fin Input Path Sensor, the rotation speed of the Shift Roller decreases to reduce the paper transfer speed of the Shift Roller toward the Exit Roller. Due to the reduced paper transfer speed of the Shift Roller, a part of the paper located near the Chute Guide starts to deflect. Paper deflection is caused by the Regi Roller rotation faster than the Shift Roller rotation. The paper deflects successively by the Regi Roller, and after the specified pulses, the Punch Unit punches the paper. After the punching operation is finished, the Shift Roller rotation speed returns to normal speed to restart the paper transfer.

- Route for paper delivery to the Top Tray

Punching operation at the Top Tray Exit

The paper transferred from the H-Tra to the Finisher passes the Fin Input Path Sensor in the Finisher, and it is transferred toward the Exit Top Gate by the rotation of the Fin Input Roller and Regi Roller. After the trailing edge of the paper passes the Fin Input Path Sensor, the rotation speed of the Exit Top Roller: Lower decreases to reduce the paper transfer speed of the Exit Top Roller: Lower toward the Exit Roller. Due to the reduced paper transfer speed of the Exit Top Roller: Lower, a part of the paper located near the Chute Guide starts to deflect. Paper deflection is caused by the Regi Roller rotation faster than the Exit Top Roller: Lower rotation. The paper deflects successively by the Regi Roller, and after the specified pulses, the Punch Unit punches the paper. After the punching operation is finished, the Exit Top Roller: Lower rotation speed returns to normal speed to restart the paper transfer.



# 4025-Finisher

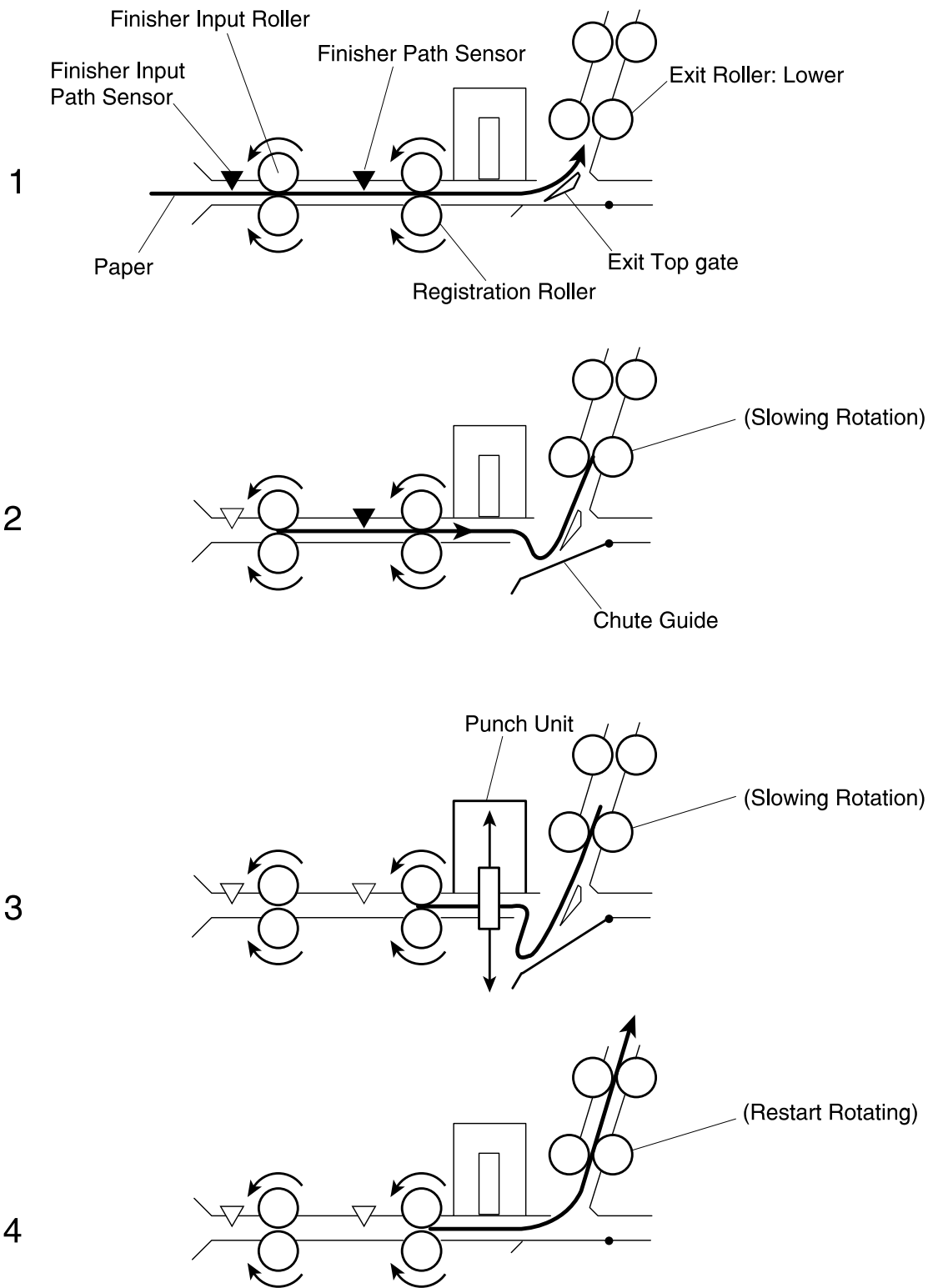

# 4025-Finisher

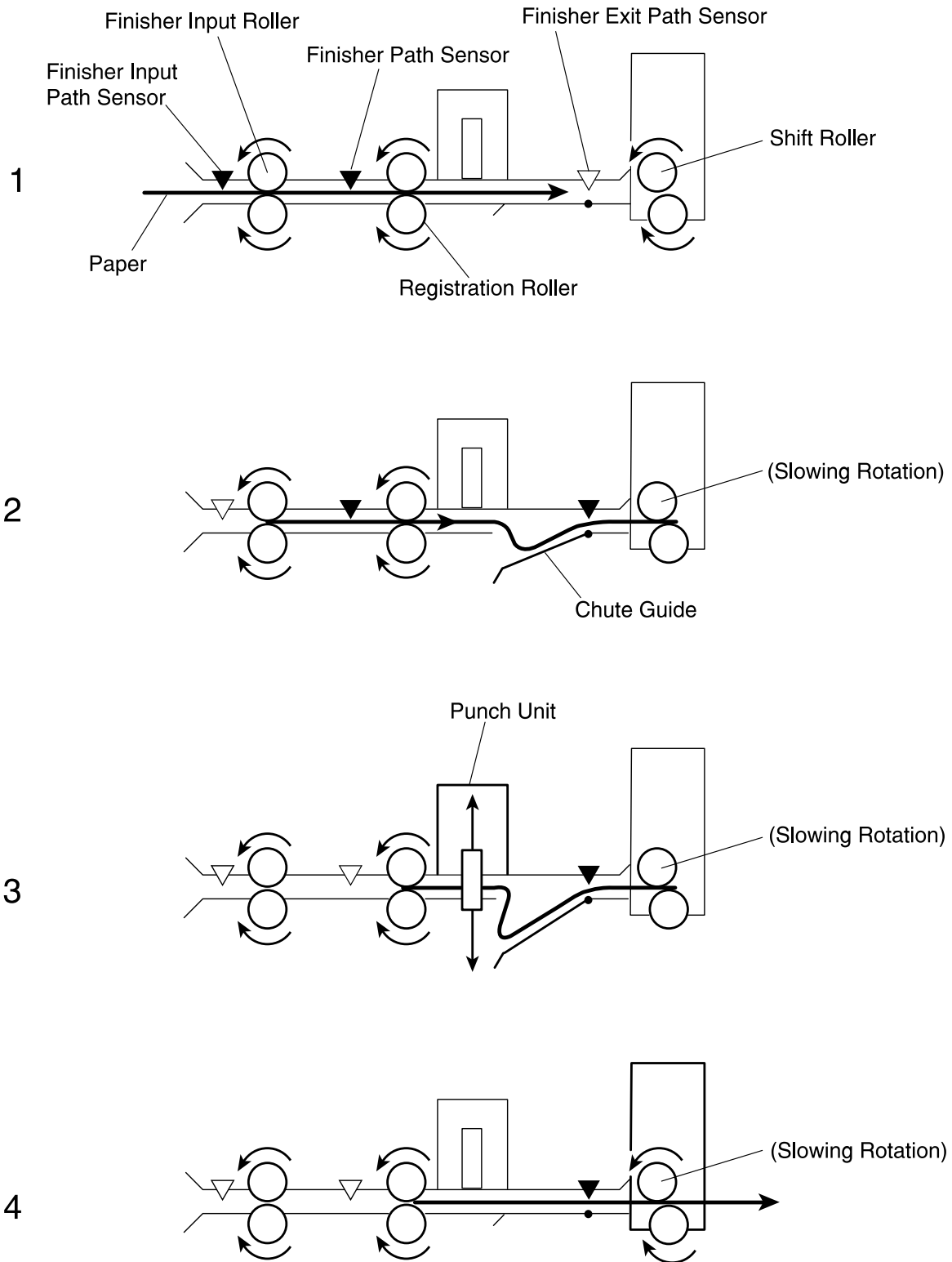

## Punch Components

- The Fin Input Path Sensor monitors paper being transferred from the H-Tra into the Finisher.
- At the specified pulses after this sensor detects the trailing edge of the paper, the Shift Roller rotation speed decreases to start the punching operation.
- The Fin Path Sensor monitors the paper passing condition between the Fin Input Roller and the Regi Roller.
- The Punch Unit punches paper.

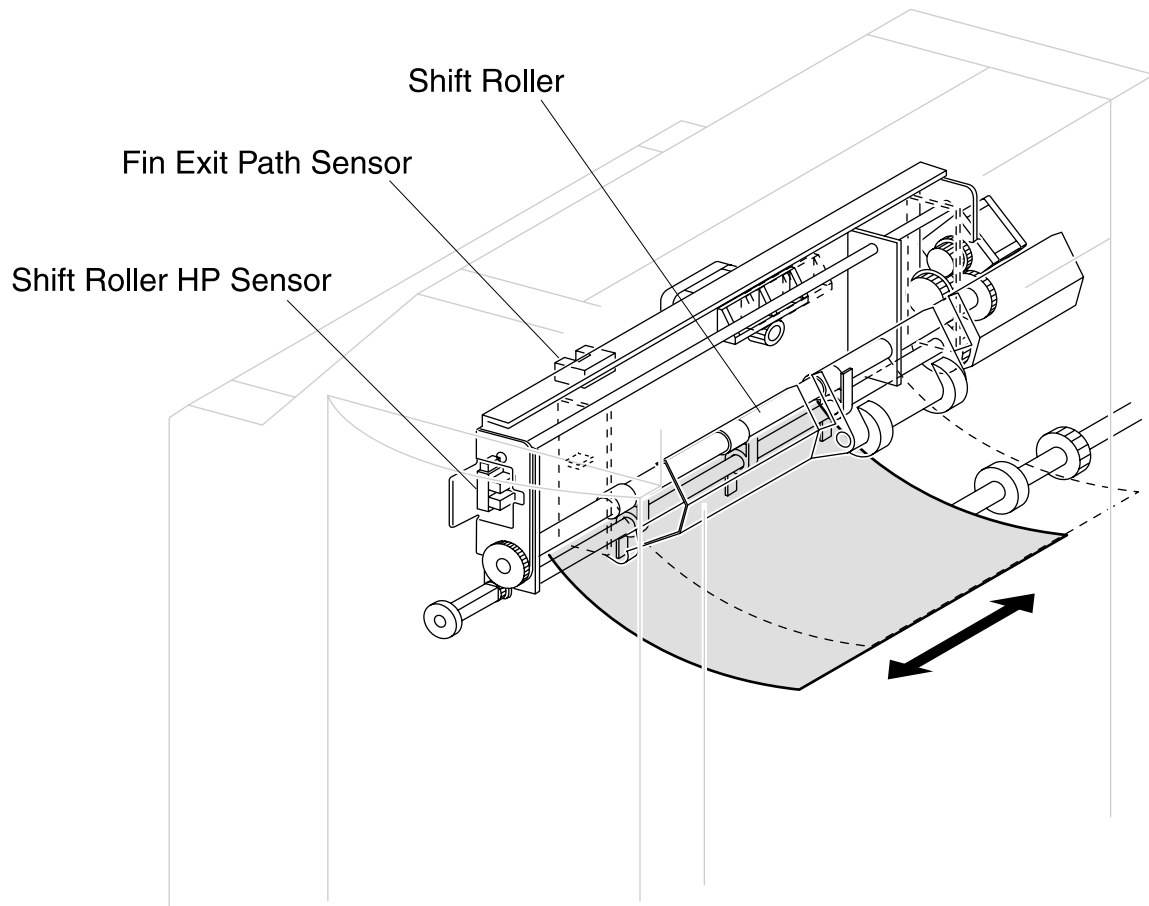

## Shift Section

After the trailing edge of paper passes the Fin Path Roller, the Exit Pinch Roll Guide opens upward. Then, the Shift Roller Unit is moved forward or backward to perform an offset job, and, at the same time, the Shift Roller rotates to transfer the paper toward the Exit Roller. Also, each time a sheet of paper is moved forward or backward, the Exit Pinch Roll Guide closes and the Exit Roller rotates to deliver the paper. Then, at the specified pulses after the Fin Exit Path Sensor detects the trailing edge of the paper, the Shift Roller Unit returns to the home position. The operation is repeated if the shift job is executed.

**Note:** The shift job cannot be executed if the stapling job is performed.

## Shift Components

- The Fin Path Sensor monitors the paper passing condition between the Fin Input Roller and the Regi Roller.
- The Fin Exit Path Sensor monitors paper passing condition before the Shift Roller.
- The Shift Roller transfers paper toward the Exit Roller.
- The Shift Roller HP Sensor detects the home position of the Shift Roller Unit.

## Compiler & Jogger Section

The paper transferred toward the Shift Roller by the Regi Roller starts to be drawn into the Compiler Tray by the clockwise rotation of the Sub Paddle at the specified pulses after the Fin Exit Path Sensor before the Shift Roller detects the trailing edge of the paper. Also, the trailing edge passes the Fin Exit Path Sensor, the Exit Roller rotates counterclockwise to draw out the Compiler Move Tray. The drawn-out Compiler Move Tray assists the paper to be easily drawn into the Compiler Tray. Further, the rotation of the Main Paddle near the Compiler Tray pushes the trailing edge of the paper against the end wall in the Compiler Tray to ensure the paper alignment.

The bundle of paper transferred into the Compiler Tray is jogged by the Jogger Flap. The Jogger Flap moves rapidly to the position 10 mm before the paper edge with respect to the Jogger HP Sensor. Then, the Jogger Flap decelerates and jogs the bundle of paper.

**Note:** The stapling job cannot be executed if the Shift job is performed.

# 4025-Finisher

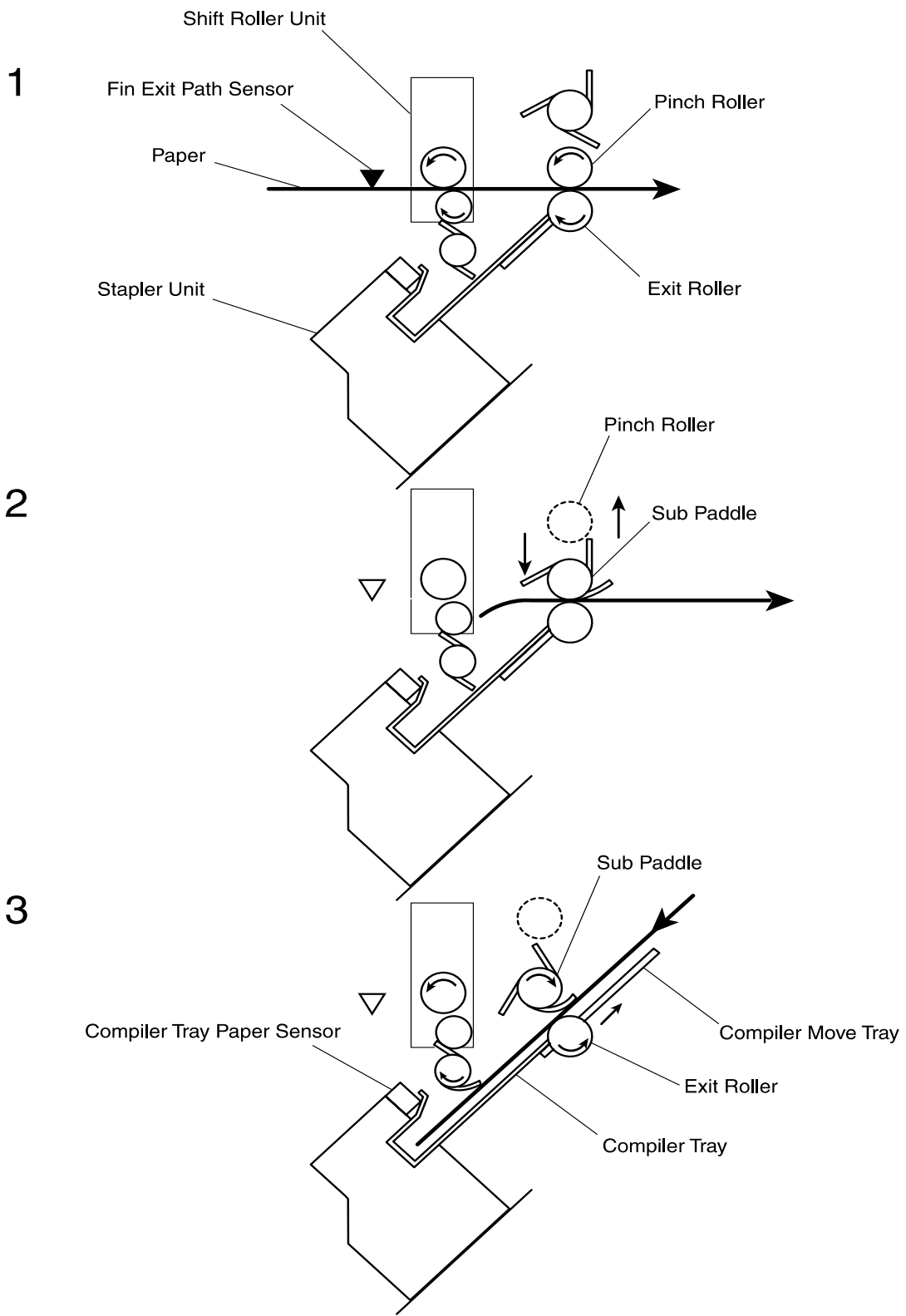

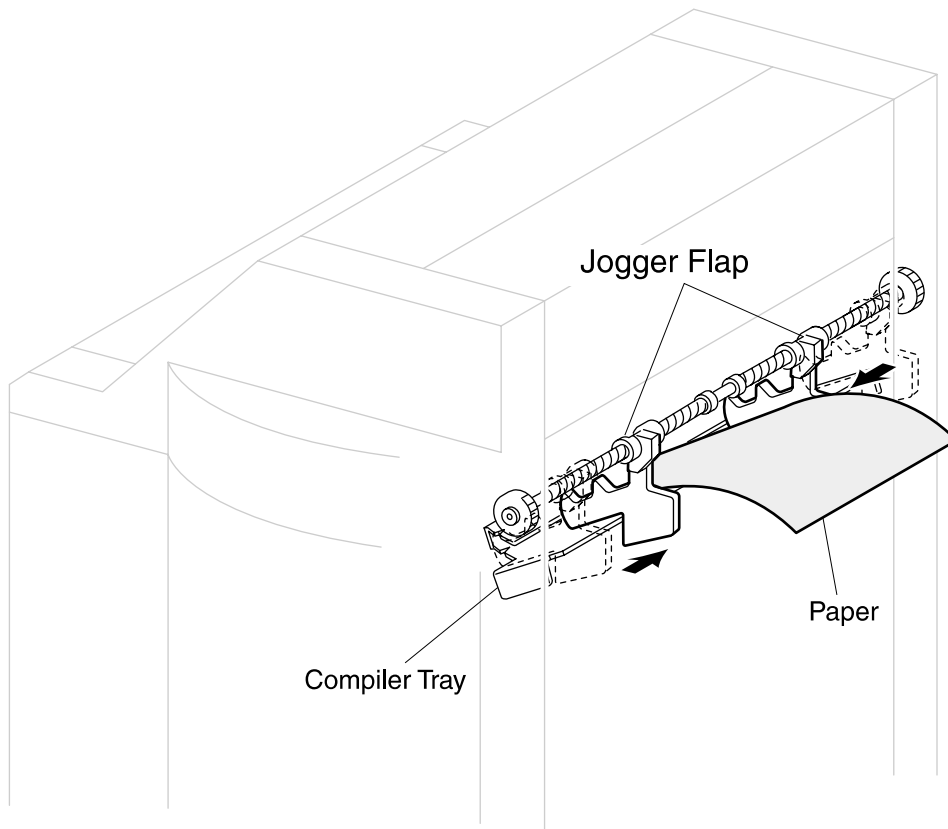

### Compiler & Jogger Components

- The Exit Roller delivers paper to the Stacker Tray, and transfers paper to the Compiler Tray.
- The Sub Paddle assists the paper to be drawn into the Compiler Tray.
- The Main Paddle draws the paper into the Compiler Tray, and then pushes the trailing edge of the paper against the end wall in the Compiler Tray.
- The Compiler Tray Paper Sensor detects the presence of paper in the Compiler.
- The Compiler Move Tray extends to assist the paper to be drawn easily into the Compiler Tray.
- The Jogger HP Sensor detects the Jogger home position to confirm the Jogger Flap position.

## Stapler Section

The Stapler staples a bundle of paper in the Compiler Tray. When performing the stapling, the Stapler Unit starts moving along rails to the paper stapler position. The Stapler Unit moves to the front side when the right side of paper is stapled, or to the rear side when the left side of paper is stapled. When the Stapler Unit moves, the Stapler Traverse HP Sensor detects the absolute position of the Stapler Unit from the presence of a notch on the guide. After the Stapler Unit moves to the paper stapler position, the bundle of paper is stapled immediately in the Dual Stapling mode, but in the Corner Stapling mode the Stapler Unit tilts 45 degrees before the bundle of paper is stapled. As for the Stapler tilt angle in the Corner Stapling mode, the Stapler tilts +45 degrees when the Stapler Unit moves to the front side, but -45 degrees when it moves to the rear side. After the Stapler staples the bundle of paper, the Exit Roller rotates together with the Main Paddle to deliver the bundle of paper to the Stacker Tray via the Exit section.

**Note:** For the Letter and A4 size paper, the stapler positions are specified.

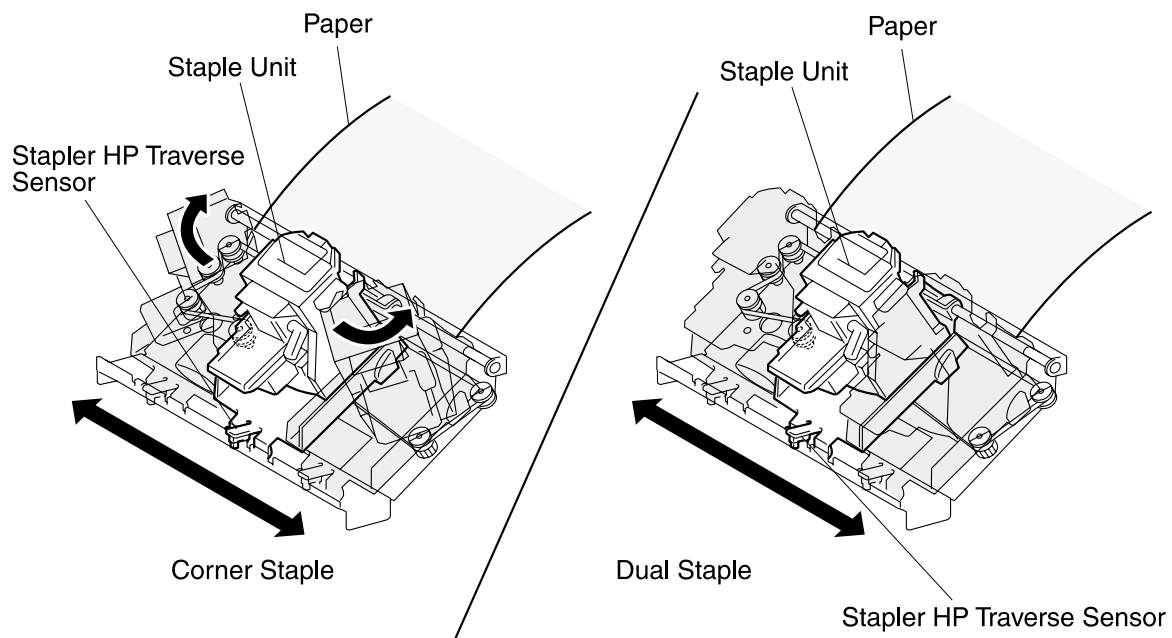

## Stapler Components

- The Stapler Unit staples a bundle of paper.
- The Stapler Traverse HP Sensor detects the absolute position of the Stapler Unit from the presence of a notch on the guide rail.



## Exit Sections

- When the stapler job is not performed

At the specified pulses after the Fin Exit Path Sensor detects the leading edge of the paper, the Exit Pinch Roll Guide lowers to nip the paper with the Exit Roller. Then the rotation of the Exit Roller delivers the paper on the Stacker Tray. After the trailing edge of the paper passes the Paper Exit Sensor, the Exit Pinch Roll Guide opens upward.

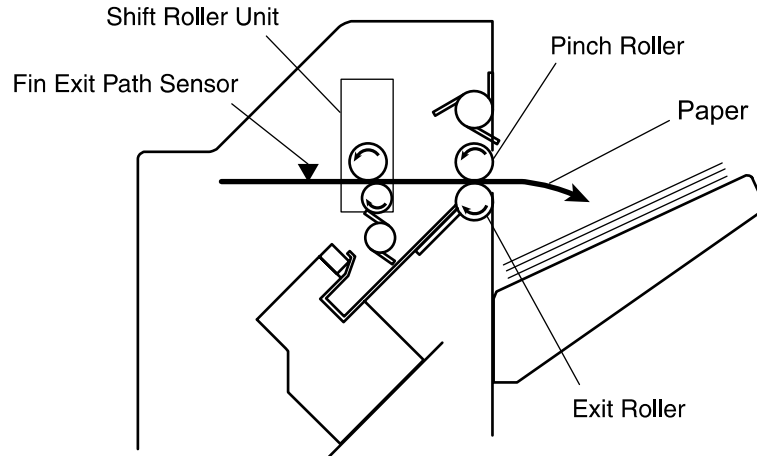

### Un-Stapling Job

- When the stapler job is performed

After the stapling operation is finished, the bundle of paper stacked on the Compiler Tray is delivered on the Stacker Tray by the rotation of the Main Paddle and Exit Roller.

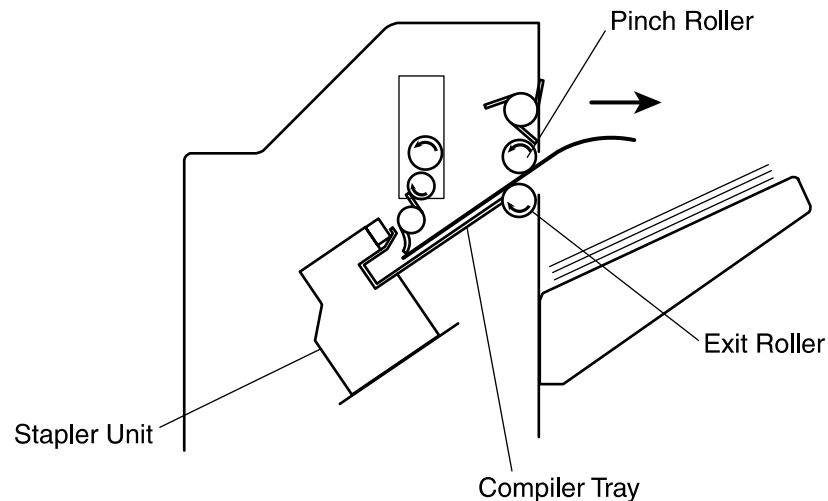

### Stapling Job

### Exit Components

- The Exit Roller delivers paper to the Stacker Tray, and transfers paper to the Compiler Tray.
- The Exit Pinch Roll Guide nips the paper with the Exit Roller to assist the paper to be delivered.
- The Paper Exit Sensor monitors the paper passing condition on the Exit Pinch Roll Guide.
- The Exit Roller Open/Close HP Sensor detects whether the Exit Pinch Roll Guide is in the home position.

## Paper Stack Sections

From the Finisher Exit section, the paper or a bundle of paper is delivered on the Stacker Tray. The Stacker Height Sensor detects the stack amount of bundles of paper, and moves up or down the Stacker Tray according to the stack amount. At the initialization, the absolute position of the Stacker Tray is recognized by the rotation of the Liner Encoder. The Stacker Tray absolute position is defined to three positions, 25%, 50%, and 100%, according to the stack amount. The slits differently spaced on the Liner Encoder correspond to respective positions. The absolute position is recognized when the Stacker Tray Position Sensor detects a slit on the Liner Encoder for the first time. The Stacker Tray moves up to the position where the Sensor B of the Stacker Height Sensor turns off.

# 4025-Finisher

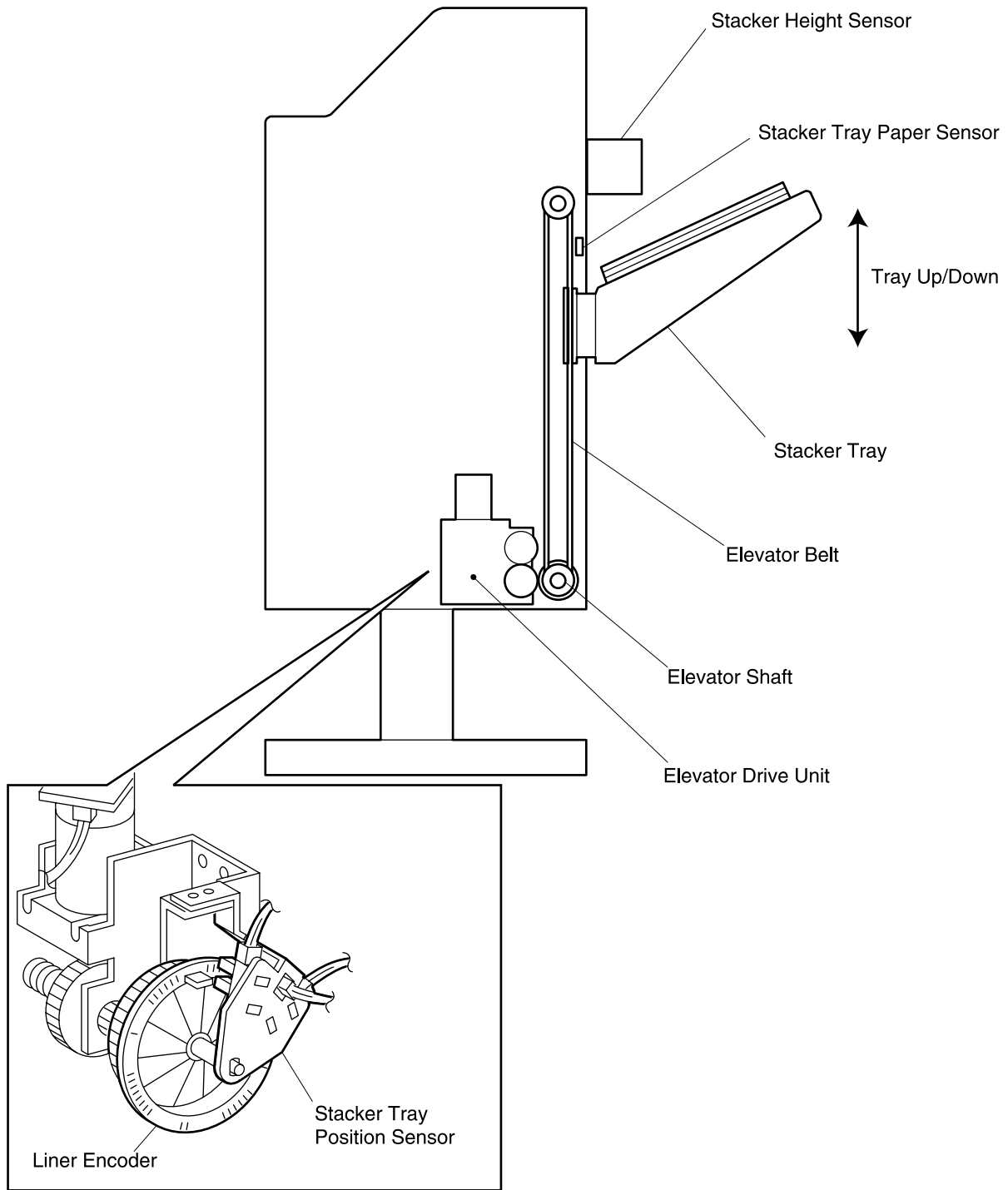

### Paper Stack Components

- The Stack Tray Paper Sensor detects the presence of paper on the Stacker Tray.
- The Stacker Tray Position Sensor detects the current position of the Stacker Tray from the Liner Encoder. The Liner Encoder has three slits differently spaced along the edge, and according to these differently spaced slits, the Stacker Tray positions on the Finisher are classified into 25%, 50% and 100% positions.
- The two sensors on the side of the Stacker Height Sensor detect the top surface of the bundle of paper on the Stacker Tray.
- Once the Stacker Tray moves down where the top surface of paper is below the Sensor B, it moves up again. After the Sensor B detects that the top surface of paper passed the Sensor B, the Stacker Tray moves up further by the specified level, and then stops. This position is the Home Position (HP).
- When the Sensor A detects the bundle of paper stacked on the Stacker Tray, the Stacker Tray moves down where the top surface of paper is below the Sensor B, and then moves up again to the home position.
- When the bundle of paper on the Stacker Tray is removed and the Sensor B detects no paper, the Stacker Tray moves up and down to the home position.

# 4025-Finisher

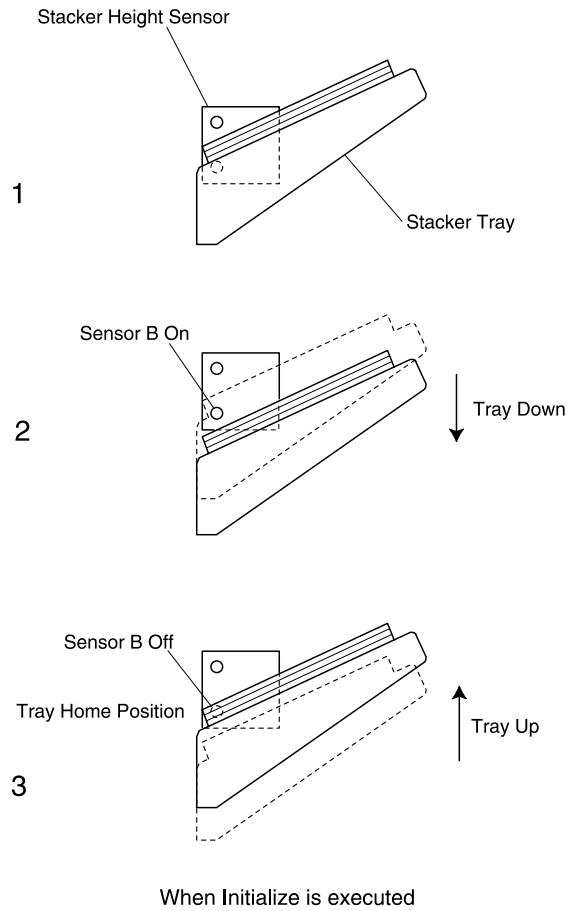
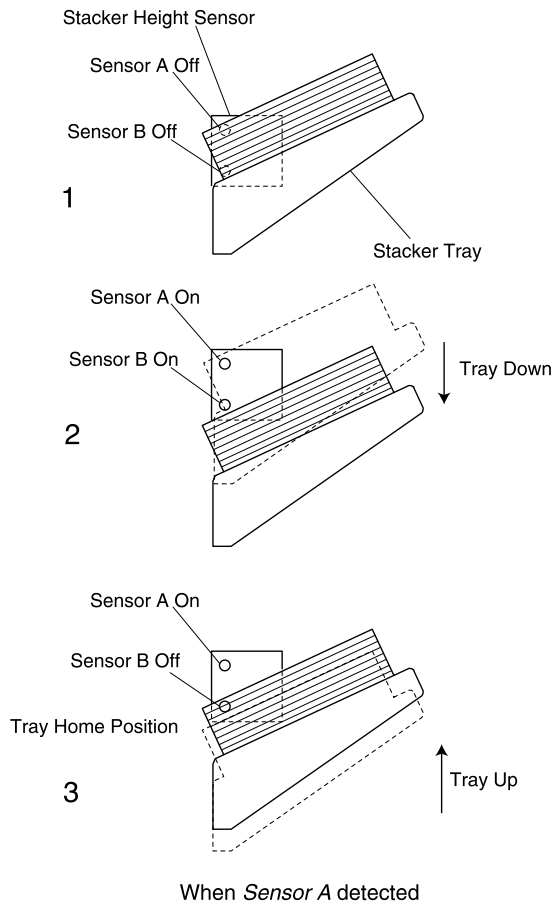

## Top Tray Exit Sections

After the trailing edge of the paper passes the Regi Roller, the paper moves toward Exit Top Gate via the Exit Top Gate. The paper is transferred toward the Top Exit by the rotation of the Exit Top Roller: Lower and Exit Top Roller: Middle on the Top Exit Chute. The paper transferred to the Top Exit section is delivered on the Top Tray by the rotation of the Exit Top Roller: Upper.

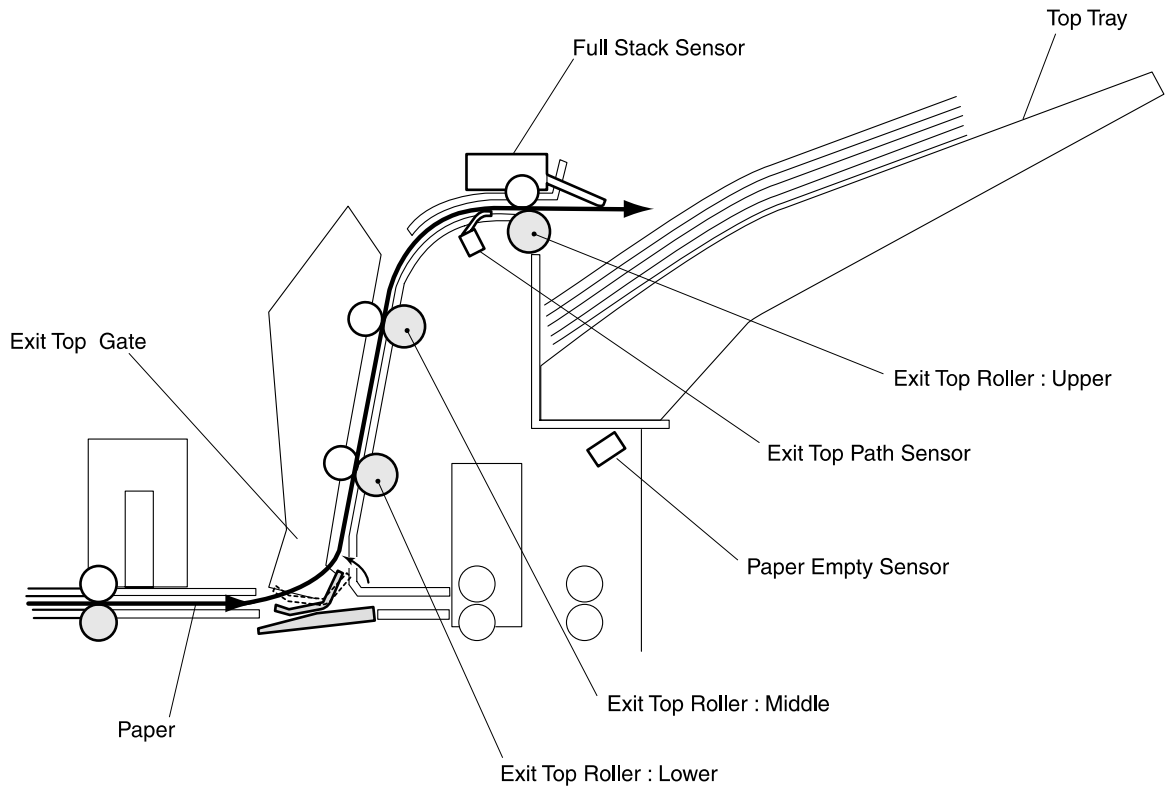

## Top Tray Exit Components

- The Exit Top Gate Solenoid changes over the Exit Top Gate.
- Changed over by the Exit Top Gate Solenoid, the Exit Top Gate transfers the paper toward the Top Tray Exit.
- Gate opens: When paper is transferred toward the H-Tra.
- Gate closes: When paper is delivered toward the Stacker Tray.
- The Exit Top Full Stack Sensor detects that the Top Tray is full with paper.
- The Exit Top Path Sensor monitors paper passing the paper exit.
- The Paper Empty Sensor detects that there is no paper on the Top Tray.

---

## Glossary of Terms, Acronyms, and Abbreviations

**A-**

AC	Alternating Current
AC Line Voltage	The AC voltage level at the AC wall outlet, such as 110VAC or 220VAC
Actuated	A device, such as a switch or motor, that is switched on
Actuator	Mechanical device used to toggle a switch or a sensor
Aux	Auxiliary

**B-**

Base Engine	The printer without options or Controller PWB installed
BCR	Bias Charge Roll
BTR	Bias Transfer Roll

**C-**

°C	Degrees Celsius. °C = 0.55 (°F - 32)
CCW	Counterclockwise
Charge	The negative voltage that the High Voltage Power Supply applies to the surface of the drum
Continuity	A resistance reading of approximately 0 ohms
Controller PWB	The electrical interface between the printer MCU and the host computer. See ESS
CL	Close
CRU	Customer Replaceable Unit, such as an EP Cartridge
CW	Clockwise

**D-**

DC	Direct Current
DB	Signal name for the Developer Bias voltage
Deactuated	A device, such as a switch or a motor, that is switched off
Develop	The part of the print cycle where toner adheres to the latent image on the drum
Developed image	The visible image on the drum after going through development
Diagnostics	The mode of operation that lets you check various components, such as sensors, solenoids, and motors
DPI	Dots Per Inch. The measure of image resolution
DRAM	Dynamic Random Access Memory
Drum	The Xerographic photoreceptor
DTS	Signal name for the Detack Saw voltage
Duplex	Printing on both sides of a single sheet of paper

**E-**

Earth	Electrical ground
-------	-------------------



## 4025-Finisher

Earth Plate	Electrical ground plate or ground strap
EP Cartridge	A sealed assembly that houses the xerographic drum, major xerographic components, and a finite supply of dry ink. The EP Cartridge is a CRU.
Error Code	A unique set of letters and numbers that the printer control system displays to indicate that a problem exists in a specific area of the printer
ESS	Electronic Subsystem. Synonym for the Controller PWB
Exposure	The action of the laser beam striking and discharging select areas of the electrically charged surface of the drum

### F-

°F	Degrees Fahrenheit. °F = (°C x 1.8) + 32
Face Down Tray	Standard output tray for the printer. Delivers paper face down.
Factory default	An operational value or parameter that is set at the time of equipment manufacture
FG	Frame Ground
FRU	Field Replaceable Unit
Fuser	The printer subsystem that uses heat and pressure to permanently adhere, or fuse, a transferred toner image to a sheet of paper

### G-

Ground	Electrical ground
--------	-------------------

### H-

Harness	A bundle of wires that form a single unit and generally terminated with connectors at both ends
HCF	High Capacity Feeder
High ( <i>signal</i> )	A signal voltage that is equal to or almost equal to the base voltage; such as +5VDC or +24VDC.
HS	High Speed
HVPS	High Voltage Power Supply

### I-

Image density	The relative darkness of the toner image on a sheet of paper
Image development	Toner turning the latent image into a visible image.
Image fusing	Using heat and pressure to permanently adhere the toner image to a sheet of paper
Image transfer	Moving the developed image from the surface of the drum to the surface of a sheet of paper
Input test	Diagnostic routine that is used to test switches and sensors
Interlock	Interlock switch or circuit. Used as a safety measure to remove voltage from circuits whenever the printer covers are open or printer assemblies are not in position
IOT	Image Output Terminal. Acronym that is sometimes used in schematic diagrams to describe the base print engine

## 4025-Finisher

### J-

J Jack. A female electrical connector

### L-

Laser Refers to either the Laser Diode Assembly or to the laser beam

Laser beam path The path the laser beam takes, through lenses and mirrors, from the Laser Diode to the surface of the drum

Laser Diode Semiconductor device that generates the laser beam used in the Printhead

Latent image The invisible, electrical image remaining on the surface of the drum after exposure

LCD Liquid Crystal Display

LD Laser Diode

LED Light Emitting Diode

L/H Left Hand

Low (*signal*) A signal voltage that is significantly lower than the base voltage

LS Low Speed

LVPS Low Voltage Power Supply

### M-

MCU Machine Control Unit. The PWB that controls the operation of the printer

MBX Mailbox

MOT Motor

### N-

NC No Connection

NVRAM Non-Volatile Random Access Memory

### O-

OHP Transparency print media

OP Open

Output test Diagnostic routine used to switch on motors, solenoids, and clutches

### P-

P Plug. A male electrical connector

Paper jam A sheet of paper stops at a point along the paper path

Paper path The path a sheet of paper takes from the paper feeder to the output tray

P/H Paper Handling

P/J Plug and Jack. Electrical connectors as a unit

PL Parts List

PPM Pages Per Minute or Prints Per Minute

## 4025-Finisher

Pre-Reg	Pre-Registration
Print cycle	The printer creating and delivering one finished print
Print surface	The side of a sheet of paper that receives the printed image
PS	Power Supply
PWB	Printed Wiring Board (sometimes referred to as PCB or Printed Circuit Board)

### R

R	Right
Reg or Regi	Registration
R/H	Right Hand
ROM	Read Only Memory
RTN	Return

### S

Sensor	A device used to monitor a function or operation, such as paper travel along the paper path
SG	Signal Ground
Signal name	A name assigned to a wire, indicating the purpose of the wire and/or the voltage carried by that wire
SNR	Sensor
SOL	Solenoid
SOS	Start Of Scan
STA	Status
STS	Soft Touch Sensor
SW	Switch

### T

Temp	Temperature
Test Print	A grid pattern print that is generated by the MCU
Test Print Mode	The mode of operation that lets you generate a test print
Toggle	To switch between two states, such as on and off or up and down
Toner	The dry ink that is used to create the visible image. Toner is stored in the EP Cartridge
Transfer	Moving the toner image from the surface of the drum to the surface of a sheet of paper

### V-

V	Volts
VAC	Volts - Alternating Current
VDC	Volts - Direct Current

### W-

Warm-up	The time it takes the printer to go from main power ON to Ready to Print
---------	--

## 4025-Finisher

Wire Harness

A bundle of wires that form a single unit and are generally terminated with connectors at both ends

## 2. Diagnostic Information

### Start

**CAUTION:** Remove the power cord from the printer or wall outlet before you connect or disconnect any cable or electronic board or assembly for personal safety and to prevent damage to the printer or Finisher. Make sure your fingers are not under the printer when you lift or set the printer down.

Use the service error code table, attendance message table, attendance message service checks, and service error code service checks to determine the corrective action necessary to repair the Finisher. Verify the repair upon completion of service.

- **“Service Error Code Table” on page 2-4**
- **“Attendance Message Table” on page 2-5**
- **“Attendance Message Service Checks” on page 2-12**
- **“Service Error Code Service Checks” on page 2-29**

### Operator Panel Messages

The operator panel messages are divided into four types: **Status Screens**, **Status Messages**, **Attendance Messages**, and **Service Messages**. The characteristics of each type is described in this chapter. The messages are displayed in the following priority order:

1. Status screens (*lowest priority*)
2. Status messages
3. Service messages (*highest priority*)
4. Attendance messages

The printer prioritizes the operator panel messages within each type, if they occur simultaneously.

#### Status Screens

Each of these message screens provide the operator with information on the current state of the printer. Each screen of information provides various status information.

Each status screen includes the capability to display a *warning message*.

#### Ready

Ready <warning>
--------------------

Ready Screen

Ready <fax status> <warning>
---------------------------------

Ready/Fax Screen

The above is a representation of the operator panel when the printer is in the Ready state. The printer is ready to receive and process data from a host system.

## **Status Messages**

These messages provide the operator with information on the current state of the printer. Generally, no user intervention is required.

## **Service Messages**

These messages are displayed whenever the printer is in the Operator Intervention state, and the printer needs servicing. In general, service errors are non-recoverable. However, it may be possible to power the printer off and back on to temporarily recover from the error condition if it is intermittent in nature.

When a Service Message occurs, the printer stops printing. The only recovery is to power off the printer.

## **Attendance Messages**

These messages are displayed when the printer is in the Operator Intervention state. The operator is provided with a description of the operator intervention condition.

When an operator intervention condition occurs, all host links will be notified about the intervention required condition.

All timeouts will be stopped while the printer is in an operator intervention state. The only exception is the PostScript™ Feed Timeout. This timeout will be started when the Load Paper message is displayed for the manual source.

## Close Door Messages

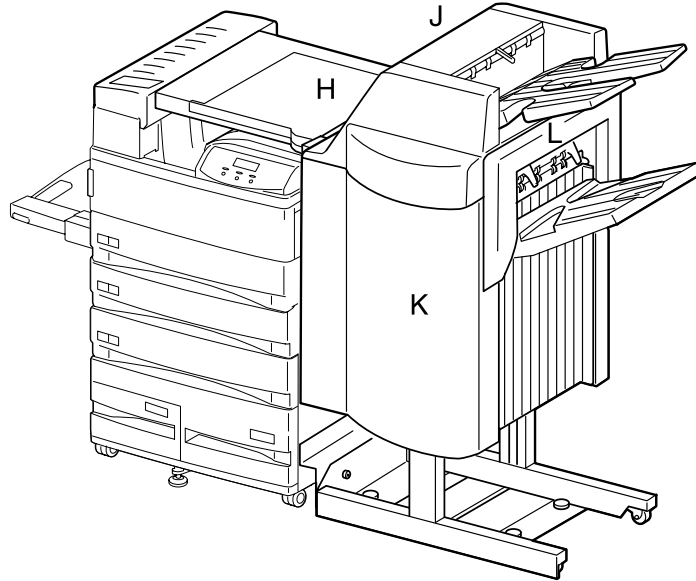

Close Door <b>K</b>	Close Door or check <b>Front Cover K Switch</b>
Close Cover <b>J</b>	Close Top Cover or check <b>Top Cover J Sensor</b>
Close Cover <b>H</b>	Close Horizontal Transport Cover or check <b>H-TRA Cover H Sensor</b>
Release Surface <b>L</b>	Check <b>Exit Roll Sensor</b>

## Accessing Additional Debug Information for Service Errors

Additional debug information may be available for the specific service error being displayed. This information may help the Customer Support Center, customer engineer, and support engine resolve the problem.

To access this information:

1. Press and hold **Return** and then press and release **Select**. The first screen of debug information is displayed. Write this information down.
2. Continue pressing **Return+Select** until each screen of debug data is obtained. Once the end of the debug data is reached, the original service message is displayed.

---

**Service Error Code Table**

<b>9xx Code</b>	<b>Second Line Message</b>	<b>Description</b>
980	Finisher Comm.	Finisher communication. Go to <b>“980 - Error Code Service Check” on page 2-29.</b>
981	Fin Non-Stapling	Mechanical failure in stacker tray 1. Go to <b>“981 - Stacker Tray Service Check” on page 2-29.</b>
982	Fin Non-Stapling	Jogger (L) failure. Go to <b>“982 - Error Code Service Check” on page 2-30.</b>
983	Fin Non-Stapling	Jogger (R) failure. Go to <b>“983 - Error Code Service Check” on page 2-31.</b>
984	Fin Non-Stapling	Finisher mechanical failure. Go to <b>“984 - Error Code Service Check” on page 2-32.</b>
985	Fin Non-Stapling	Finisher mechanical failure. Go to <b>“985 - Error Code Service Check” on page 2-34.</b>
986	Fin Non-Stapling	Finisher mechanical failure. Go to <b>“986 - Error Code Service Check” on page 2-35.</b>
987	Fin Stapling	Mechanical failure in stapling part. Go to <b>“987 - Error Code Service Check” on page 2-36.</b>
988	Fin Stapling	Mechanical failure in stapling part. Go to <b>“988 - Error Code Service Check” on page 2-37.</b>
989	Fin Stapling	Mechanical failure in stapling part. Go to <b>“989 - Error Code Service Check” on page 2-38.</b>
990	Fin Stapling	Mechanical failure in stapling part. Go to <b>“990 - Error Code Service Check” on page 2-40.</b>
991	Fin Stapling	Mechanical failure in stapling part. Go to <b>“991 - Error Code Service Check” on page 2-41.</b>
992	Fin Stapling	Mechanical failure in stapling part. Go to <b>“992 - Error Code Service Check” on page 2-42.</b>
995	Wrong Finisher	Incorrect finisher option. Go to <b>“995 - Error Code Service Check” on page 2-43.</b>
999	Finisher Error	The engine has reported a Finisher failure that the RIP code does not recognize.

<i>2xx Paper Jam</i> <i>Second Line Msg</i>
--

Primary Message

<i>Flip Flop 1</i> <i>Flip Flop 2</i>
--

Secondary Message



---

**Attendance Message Table**

<b>2XX</b>	<b>Second Line Message</b>	<b>Flip Flop 1</b>	<b>Flip Flop 2</b>	<b>Description</b>
200	Open Door A	Leave Staple Job	in Finisher	Register Area
201	Open Door A	Leave Staple Job	in Finisher	Register Area
202	Open Door A	Leave Staple Job	in Finisher	Register Area
204	Open Door A	Leave Staple Job	in Finisher	Fuser Area
206	Open Door A	Leave Staple Job	in Finisher	Print Exit Area
207	Open Door E	Leave Staple Job	in Finisher	Print Exit Area
208	Open Door A	Leave Staple Job	in Finisher	Print Exit Area
209	Open Door A	Leave Staple Job	in Finisher	Print Exit Area
210	Open Door E	Leave Staple Job	in Finisher	Print Exit Area (no duplex installed)
211	Open Door A	Leave Staple Job	in Finisher	Print Exit Area (duplex installed)
231	Open Door E	Leave Staple Job	in Finisher	Duplex Area
232	Open Door E	Leave Staple Job	in Finisher	Duplex Area
233	Open Door E	Leave Staple Job	in Finisher	Duplex Area
234	Open Door E	Leave Staple Job	in Finisher	Duplex Area
241	Open Door A	Leave Staple Job	in Finisher	Input Area
241	Open Tray 1	Leave Staple Job	in Finisher	Input Area (second message)
242	Open Door B	Leave Staple Job	in Finisher	Input Area
242	Open Tray 2	Leave Staple Job	in Finisher	Input Area (second message)
243	Open Door A	Leave Staple Job	in Finisher	Input Area
244	Open Door B	Leave Staple Job	in Finisher	Input Area
244	Open Tray 3	Leave Staple Job	in Finisher	Input Area (second message)
245	Open Doors A,B	Leave Staple Job	in Finisher	Input Area
246	Open Door B	Leave Staple Job	in Finisher	Input Area
247	Open Door C	Leave Staple Job	in Finisher	Input Area
247	Open Tray 4	Leave Staple Job	in Finisher	Input Area (second message)
248	Open Doors B,C	Leave Staple Job	in Finisher	Input Area
249	Open Door C	Leave Staple Job	in Finisher	Input Area
250	Open Door B	Leave Staple Job	in Finisher	Input Area
251	Open Door C	Leave Staple Job	in Finisher	Input Area
251	Open Tray 5	Leave Staple Job	in Finisher	Input Area (second message)

## Attendance Message Table

2XX	Second Line Message	Flip Flop 1	Flip Flop 2	Description
252	Open Doors B,C	Leave Staple Job	in Finisher	Input Area
253	Open Doors A,B,C	Leave Staple Job	in Finisher	Input Area
254	Open Door C	Leave Staple Job	in Finisher	Input Area
254	Open Tray 5	Leave Staple Job	in Finisher	Input Area (second message)
255	Open Door A	Leave Staple Job	in Finisher	Input Area
255	Remove MP Feeder	Leave Staple Job	in Finisher	Input Area (second message if MP Feeder is installed)
255	Remove Envelope	Leave Staple Job	in Finisher	Input Area (second message if Envelope Feeder is installed)
256	Open Doors A,B	Leave Staple Job	in Finisher	Input Area
257	Open Door B	Leave Staple Job	in Finisher	Input Area
258	Open Door C	Leave Staple Job	in Finisher	Input Area
259	Open Door C	Leave Staple Job	in Finisher	Input Area
259	Open Tray 5	Leave Staple Job	in Finisher	Input Area (second message)
260	Open Door E	Leave Staple Job	in Finisher	Input Area
261	Open Doors B,C	Leave Staple Job	in Finisher	Input Area
271	Remove Envelope Feeder	Leave Staple Job	in Finisher	Input Area
272	Remove Envelope Feeder	Leave Staple Job	in Finisher	Input Area
273	Remove Envelope	Leave Staple Job	in Finisher	Input Area (Envelope Feeder installed)
273	Remove MP Paper	Leave Staple Job	in Finisher	Input Area (MP Feeder installed)
280	Open Door D	Leave Staple Job	in Finisher	Mailbox Input Area
281	Open Door D	Leave Staple Job	in Finisher	Mailbox Input Area
282	Open Door D	Leave Staple Job	in Finisher	Mailbox Input Area
284	Open Door D	Leave Staple Job	in Finisher	Mailbox Area
285	Open Door D	Leave Staple Job	in Finisher	Mailbox Area
280	Open Cover H	Leave Staple Job	in Finisher	Horizontal Transport Area - Go to <b>"280 - Attendance Message"</b> on page 2-12.

## Attendance Message Table

2XX	Second Line Message	Flip Flop 1	Flip Flop 2	Description
281	Open Cover H	Leave Staple Job	in Finisher	Horizontal Transport Area - Go to <b>"281 - Attendance Message"</b> on page 2-13.
282	Open Cover H	Leave Staple Job	in Finisher	Horizontal Transport Area - Go to <b>"282 - Attendance Message"</b> on page 2-14.
283	Open Cover H	Leave Staple Job	in Finisher	Horizontal Transport Area - Go to <b>"283 - Attendance Message"</b> on page 2-15.
284	Open Cover H	Leave Staple Job	in Finisher	Horizontal Transport Area - Go to <b>"284 - Attendance Message"</b> on page 2-16.
285	Open Cover H	Leave Staple Job	in Finisher	Horizontal Transport Area - Go to <b>"285 - Attendance Message"</b> on page 2-17.
286	Open Cover H	Leave Staple Job	in Finisher	Horizontal Transport Area - Go to <b>"286 - Attendance Message"</b> on page 2-19.
287	Open Deflector G	Leave Staple Job	in Finisher	Finisher Deflector - Go to <b>"287 - Attendance Message"</b> on page 2-20.
288	Open Door K	Leave Staple Job	in Finisher	Finisher Area - Go to <b>"288 - Attendance Message"</b> on page 2-21.

---

**Attendance Message Table**

2XX	Second Line Message	Flip Flop 1	Flip Flop 2	Description
289	Open Door K	Leave Staple Job	in Finisher	Finisher Area - Go to <b>“289 - Attendance Message”</b> on page 2-23.
290	Open Door K	Leave Staple Job	in Finisher	Finisher Area - Go to <b>“290 - Attendance Message”</b> on page 2-24.
291	Open Door K	Leave Staple Job	in Finisher	Finisher Area - Go to <b>“291 - Attendance Message”</b> on page 2-25.
292	Open Cover J	Leave Staple Job	in Finisher	Finisher Top Cover - Go to <b>“292 - Attendance Message”</b> on page 2-26.
293	Open Cover J	Leave Staple Job	in Finisher	Finisher Top Cover
294	Open Cover J	Leave Staple Job	in Finisher	Finisher Top Cover
295	in Finisher	Clear Staple Job	from Finisher	Finisher Accumulator - Go to <b>“295 - Attendance Message”</b> on page 2-27.

## Service Checks Flowchart

### How to Use the Service Checks Flowchart

- Follow your problem to the individual Primary Service Check that corresponds to your error code, printer operation problem, or print image problem.
- Follow the instructions presented in the Service Check.
- Voltage and resistance values presented in the Service Checks are an approximation. Actual readings may vary from the stated values.
- Primary Service Checks may direct you to a Secondary Service Check.

### How to Follow a Service Check

(See the sample service check step below).

1. Each numbered step in a service check instructs you to perform a certain action or procedure.
2. The **Actions and Questions** box may contain additional information and numbered procedure steps you must follow to perform the action.
3. The action is followed by a question.
4. If your response to the question is **Yes**, then follow the instructions for a Yes reply.
5. If your response to the question is **No**, then follow the instructions for a No reply.
6. Service Checks may ask you to take voltage readings at certain test points within the printer.
7. Service Checks may ask you to run a specific diagnostic routine in order to test a FRU or circuit.
8. Service Checks often ask you to replace a printer FRU. *Removal and Replacement Procedures* provide you detailed steps for removing and replacing major parts of the printer.

Step	Actions and Questions	Yes	No
1	<p><b>NO PAPER SENSOR TEST</b></p> <ol style="list-style-type: none"> <li>1. Enter Diagnostics and test Tray 3 No Paper Sensor.</li> <li>2. Slide Tray 3 out of the printer.</li> <li>3. Manually actuate and deactuate Tray 3 No Paper Sensor.</li> </ol> <p><b>Does the last number in the Diagnostics Status Window toggle between OP and CL?</b></p>	Go to following step	Replace the No Paper Sensor

## General Notes on Using Service Checks

- Unless indicated otherwise, the instruction “switch ON printer main power” means for you to switch ON printer power and let the printer proceed through power-on diagnostics and warm-up until it is online and ready to print.
- Conventions used to represent connectors:
  - P/J XX means a Plug and its corresponding Jack are connected.
  - PXX means a Plug is disconnected. (Unless this plug is soldered to a board).
  - JXX means a Jack is disconnected. (Unless this jack is soldered to a board).
  - When you are instructed to take a voltage reading between “P/J A–B and P/J X–Y,” place the red probe (+) of your meter on pin B of P/J A, and place the black probe (–) of your meter on pin Y of P/J X.
  - When you are instructed to take voltage readings between “P/J X and P/J Y” (without specified pin numbers), check all voltage carrying pins. Refer to the Wiring Diagrams for signals and pin numbers.
  - When you are instructed to take a voltage reading, the black probe (–) is generally connected to a pin that is either RTN (Return) or SG (Signal Ground). You can substitute any RTN pin or test point in the printer, and you can use FG (Frame Ground) in place of any SG pin or test point.
  - Unless a Service Check instructs you otherwise; before measuring voltages, make sure the printer is switched ON, the Print Cartridge and the Paper Cassettes are in place, and all of the interlock switches are actuated.
  - All voltage values given in the Service Checks are approximate values. Actual measured voltages may vary more than 25% from the values stated in the Service Checks. The main purpose of most voltage readings taken in the Service Checks is to determine whether or not a FRU is receiving the correct voltage value from the power supply and if gating (a voltage drop) occurs during FRU actuation. Gating signals may be nothing more than a pulse, resulting in a momentary drop in voltage that may be difficult or impossible to read on the average multimeter.
  - Service Checks may instruct you to remove or replace a FRU. See "Removal and Replacement Procedures" for information on how to remove and reinstall a FRU.
  - When a Service Check instructs you to replace a FRU, and that FRU is part of a larger assembly, you should replace the entire assembly.

---

## Service Checks

Before entering the service checks:

1. Is the AC power provided at the electrical outlet within specifications for this printer; either 110 V ac or 220 V ac?
2. Is the AC power cord in good condition; neither frayed nor broken?
3. Is one end of the AC power cord connected to the printer?
4. Is the other end of the AC power cord plugged into a grounded three-prong AC electrical outlet?
5. Is the printer located in an area where the temperature and humidity are moderate and stable?
6. Is the printer located in an area free of dust?
7. Is the printer located away from water outlets, steamers, electric heaters, volatile gases, or open flames?
8. Is the printer shielded from the direct rays of the sun?
9. Does the printer have adequate ventilation space around all sides?
10. Is the printer sitting on a level and stable surface?
11. Is the paper stock used in the printer as recommended in the User Manual?
12. Does the customer use the printer as instructed in the User Manual?
13. Are consumables replaced at the recommended intervals?
14. Do you have access to Printer Diagnostics and do you know how to use them?
15. Are all of the printer assemblies in place and are all printer covers and doors firmly closed?

## Attendance Message Service Checks

### 280 - Attendance Message

Logic Control sensed that the H-Tra Input Sensor was not deactivated within a specified time after it was actuated.

Step	Actions and Questions	Yes	No
1	<b>PATH LOCATION INSPECTION</b> Inspect the position of the sheet of paper in the H-Tra. <b>Has the trail edge of the sheet of paper cleared the H-Tra Input Sensor?</b>	Go to step 2	Go to step 5
2	<b>SENSOR TEST</b> Enter Diagnostics and check the H-Tra Input Sensor function. Insert then remove a sheet of paper into the sensor. <b>Does the Operator Panel LCD change between OP and CL as you insert then remove the paper?</b>	Go to step 4	Go to step 3
3	<b>H-TRA INPUT SENSOR</b> Replace the H-Tra Input Sensor. Go to <b>“Sensors Removal” on page 4-20</b> . Enter Diagnostics and check the H-Tra Input Sensor function. Insert then remove a sheet of paper into the sensor. <b>Does the Operator Panel LCD change between OP and CL as you insert then remove the paper?</b>	Problem solved	Go to step 4
4	<b>FINISHER MAIN BOARD</b> Replace the Finisher Main Board. Go to <b>“PWB Assembly-Main Removal” on page 4-132</b> . Enter Diagnostics and check the H-Tra Input Sensor function. Insert then remove a sheet of paper into the sensor. <b>Does the Operator Panel LCD change between OP and CL as you insert then remove the paper?</b>	Problem solved	Replace the MCU Board
5	<b>PATH PAPER INSPECTION</b> Inspect the Drive Rolls in the entire H-Tra Assembly. <b>Are all of the Drive Rolls in the H-Tra Assembly clean and free of obvious wear and damage?</b>	Go to step 6	Replace the suspect Drive Rolls
6	<b>DRIVE TRAIN TEST</b> Enter Diagnostics and select Output Bin Tests. Select Feed Test, Output Bin 2 to run the Finisher Main Feed Motor. <b>Does the Finisher Main Feed Motor run smoothly?</b>	Go to step 7	Replace the Finisher Main Feed Motor
7	<b>DRIVE TRAIN INSPECTION</b> Inspect the drive train, including belts, pulleys, and gears, of the entire H-Tra Assembly from the Finisher Main Feed Motor to Feed Roller 1. <b>Does the entire drive train of the H-Tra Assembly appear to be in good condition, with no damaged or slipping belts and no chipped or broken pulleys or gears?</b>	Go to step 8	Replace the suspect belts, pulleys, and gears



## 4025-Finisher

Step	Actions and Questions	Yes	No
8	<p>The following Finisher FRUs and areas are associated with this specific problem. One or more of these FRUs or areas may have failed partially or completely. If you cannot isolate this problem using these steps, replace each FRU or troubleshoot each area listed below, one at a time, until you isolate and solve the problem.</p> <p>Wiring and connectors linking the components Finisher Main Board MCU Board</p>		

### 281 - Attendance Message

Logic Control sensed that the H-Tra Input Sensor was actuated during Finisher initialization.

Step	Actions and Questions	Yes	No
1	<p><b>SENSOR INSPECTION</b> Inspect the H-Tra Input Sensor for a piece of paper or something else actuating the Sensor. <b>Is there a piece of paper or something else actuating the Sensor?</b></p>	Remove whatever is actuating the Sensor	Go to step 2
2	<p><b>SENSOR TEST</b> Enter Diagnostics and check the H-Tra Input Sensor function. Insert then remove a sheet of paper into the sensor. <b>Does the Operator Panel LCD change between OP and CL as you insert then remove the paper?</b></p>	Go to step 4	Go to step 3
3	<p><b>H-TRA INPUT SENSOR</b> Replace the H-Tra Input Sensor. Go to <b>“Sensors Removal” on page 4-20</b>. Enter Diagnostics and check the H-Tra Input Sensor function. Insert then remove a sheet of paper into the sensor. <b>Does the Operator Panel LCD change between OP and CL as you insert then remove the paper?</b></p>	Problem solved	Go to step 4
4	<p><b>FINISHER MAIN BOARD</b> Replace the Finisher Main Board. Go to <b>“PWB Assembly-Main Removal” on page 4-132</b>. Enter Diagnostics and check the H-Tra Input Sensor function. Insert then remove a sheet of paper into the sensor. <b>Does the Operator Panel LCD change between OP and CL as you insert then remove the paper?</b></p>	Problem solved	Go to step 5

## 4025-Finisher

Step	Actions and Questions	Yes	No
5	<p><b>MCU BOARD</b>                      Replace the MCU Board. Refer to the Printer Service Manual. Enter Diagnostics and check the H-Tra Input Sensor function. Insert then remove a sheet of paper into the sensor.  <b>Does the Operator Panel LCD change between OP and CL as you insert then remove the paper?</b></p>	Problem solved	Go to step 6
6	<p>The following Finisher FRUs and areas are associated with this specific problem. One or more of these FRUs or areas may have failed partially or completely. If you cannot isolate this problem using these steps, replace each FRU or troubleshoot each area listed below, one at a time, until you isolate and solve the problem.</p> <ul style="list-style-type: none"> <li>• Wiring and connectors linking the FRUs</li> </ul>		

### 282 - Attendance Message

Logic Control sensed that the H-Tra Exit Sensor was not deactuated within a specified time after it was actuated.

Step	Actions and Questions	Yes	No
1	<p><b>PATH LOCATION INSPECTION</b>                      Inspect the position of the sheet of paper exiting the H-Tra Exit Sensor.  <b>Has the trail edge of the sheet of paper cleared the H-Tra Exit Sensor?</b></p>	Go to step 2	Go to step 5
2	<p><b>SENSOR TEST</b>                      Enter Diagnostics and check the H-Tra Exit Sensor function. Insert then remove a sheet of paper into the sensor.  <b>Does the Operator Panel LCD change between OP and CL as you insert then remove the paper?</b></p>	Go to step 4	Go to step 3
3	<p><b>H-TRA EXIT SENSOR</b>                      Replace the H-Tra Exit Sensor. Go to <b>“Sensors Removal” on page 4-20</b>. Enter Diagnostics and check the H-Tra Exit Sensor function. Insert then remove a sheet of paper into the sensor.  <b>Does the Operator Panel LCD change between OP and CL as you insert then remove the paper?</b></p>	Problem solved	Go to step 4
4	<p><b>FINISHER MAIN BOARD</b>                      Replace the Finisher Main Board. Go to <b>“PWB Assembly-Main Removal” on page 4-132</b>. Enter Diagnostics and check the H-Tra Exit Sensor function. Insert then remove a sheet of paper into the sensor.  <b>Does the Operator Panel LCD change between OP and CL as you insert then remove the paper?</b></p>	Problem solved	Replace the MCU Board

## 4025-Finisher

Step	Actions and Questions	Yes	No
5	<p><b>PATH PAPER INSPECTION</b> Inspect the Drive Rolls in the Finisher, especially the Input Rolls and the Registration Rolls. <b>Are all of the Drive Rolls in the Finisher clean and free of obvious wear and damage?</b></p>	Go to step 6	Replace the suspect Drive Rolls
6	<p><b>DRIVE TRAIN TEST</b> Enter Diagnostics and select Output Bin Tests. Select Feed Test, Output Bin 2 to run the Finisher Main Feed Motor. <b>Does the Finisher Main Feed Motor run smoothly?</b></p>	Go to step 7	Replace the Finisher Main Feed Motor
7	<p><b>DRIVE TRAIN INSPECTION</b> Inspect the drive train, including belts, pulleys, and gears, of the entire Finisher Assembly from the Finisher Main Feed Motor to the Registration Rolls. <b>Does the entire drive train of the Finisher Assembly appear to be in good condition, with no damaged or slipping belts and no chipped or broken pulleys or gears?</b></p>	Go to step 8	Replace the suspect belts, pulleys, and gears
8	<p>The following Finisher FRUs and areas are associated with this specific problem. One or more of these FRUs or areas may have failed partially or completely. If you cannot isolate this problem using these steps, replace each FRU or troubleshoot each area listed below, one at a time, until you isolate and solve the problem.</p> <ul style="list-style-type: none"> <li>• H-Tra drive train FRUs, including gear, belts, and rolls.</li> </ul>		

## 283 - Attendance Message

Logic Control sensed that the H-Tra Exit sensor was not actuated within a specified time after the H-Tra Input Sensor was deactuated.

Step	Actions and Questions	Yes	No
1	<p><b>PATH LOCATION INSPECTION</b> Inspect the position of the sheet of paper on the H-Tra. <b>Has the lead edge of the sheet of paper actuated the H-Tra Exit Sensor?</b></p>	Go to step 2	Go to step 5
2	<p><b>SENSOR TEST</b> Enter Diagnostics and check the H-Tra Exit Sensor function. <b>Does the H-Tra Exit Sensor test ok?</b></p>	Go to step 4	Go to step 3
3	<p><b>H-TRA EXIT SENSOR</b> Replace the H-Tra Exit Sensor. Go to <b>“Sensors Removal” on page 4-20</b>. Enter Diagnostics and check the H-Tra Exit Sensor function. <b>Does the H-Tra Exit Sensor test ok?</b></p>	Problem solved	Go to step 4

## 4025-Finisher

Step	Actions and Questions	Yes	No
4	<p><b>FINISHER MAIN BOARD</b>                      Replace the Finisher Main Board. Go to <b>“PWB Assembly-Main Removal” on page 4-132</b>. Enter Diagnostics and check the H-Tra Exit Sensor function. Insert then remove a sheet of paper into the sensor.  <b>Does the Operator Panel LCD change between OP and CL as you insert then remove the paper?</b></p>	Problem solved	Replace the MCU Board
5	<p><b>PATH PAPER INSPECTION</b>                      Inspect the Drive Rolls in the entire H-Tra Assembly.  <b>Are all of the Drive Rolls in the H-Tra Assembly clean and free of obvious wear and damage?</b></p>	Go to step 6	Replace the suspect Drive Rolls
6	<p><b>DRIVE TRAIN TEST</b>                      Enter Diagnostics and select Output Bin Tests. Select Feed Test, Output Bin 2 to run the Finisher Main Feed Motor.  <b>Does the Finisher Main Feed Motor run smoothly?</b></p>	Go to step 7	Replace the Finisher Main Feed Motor
7	<p><b>DRIVE TRAIN INSPECTION</b>                      Inspect the drive train, including belts, pulleys, and gears, of the entire H-Tra Assembly from the Finisher Main Feed Motor to Feed Roller 1.  <b>Does the entire drive train of the H-Tra Assembly appear to be in good condition, with no damaged or slipping belts and no chipped or broken pulleys or gears?</b></p>	Go to step 8	Replace the suspect belts, pulleys, and gears
8	<p>The following Finisher FRUs and areas are associated with this specific problem. One or more of these FRUs or areas may have failed partially or completely. If you cannot isolate this problem using these steps, replace each FRU or troubleshoot each area listed below, one at a time, until you isolate and solve the problem.</p> <ul style="list-style-type: none"> <li>• Wiring and connectors linking the FRUs</li> </ul>		

### 284 - Attendance Message

Logic Control sensed that the H-Tra Exit Sensor was actuated during Finisher initialization.

Step	Actions and Questions	Yes	No
1	<p><b>SENSOR INSPECTION</b>                      Inspect the H-Tra Exit Sensor for a piece of paper or something else actuating the Sensor.  <b>Is there a piece of paper or something else actuating the Sensor?</b></p>	Remove whatever is actuating the Sensor	Go to step 2

## 4025-Finisher

Step	Actions and Questions	Yes	No
2	<p><b>SENSOR TEST</b> Enter Diagnostics and check the H-Tra Exit Sensor function. Insert then remove a sheet of paper into the sensor. <b>Does the Operator Panel LCD change between OP and CL as you insert then remove the paper?</b></p>	Go to step 4	Go to step 3
3	<p><b>H-TRA EXIT SENSOR</b> Replace the H-Tra Exit Sensor. Go to <b>“Sensors Removal” on page 4-20</b>. Enter Diagnostics and check the H-Tra Exit Sensor function. Insert then remove a sheet of paper into the sensor. <b>Does the Operator Panel LCD change between OP and CL as you insert then remove the paper?</b></p>	Problem solved	Go to step 4
4	<p><b>FINISHER MAIN BOARD</b> Replace the Finisher Main Board. Go to <b>“PWB Assembly-Main Removal” on page 4-132</b>. Enter Diagnostics and check the H-Tra Exit Sensor function. Insert then remove a sheet of paper into the sensor. <b>Does the Operator Panel LCD change between OP and CL as you insert then remove the paper?</b></p>	Problem solved	Go to step 5
5	<p><b>MCU BOARD</b> Replace the MCU Board. Refer to the Printer Service Manual. Enter Diagnostics and check the H-Tra Exit Sensor function. Insert then remove a sheet of paper into the sensor. <b>Does the Operator Panel LCD change between OP and CL as you insert then remove the paper?</b></p>	Problem solved	Go to step 6
6	<p>The following Finisher FRUs and areas are associated with this specific problem. One or more of these FRUs or areas may have failed partially or completely. If you cannot isolate this problem using these steps, replace each FRU or troubleshoot each area listed below, one at a time, until you isolate and solve the problem.</p> <ul style="list-style-type: none"> <li>• Wiring and connectors linking the FRUs</li> </ul>		

## 285 - Attendance Message

Logic Control sensed that the Finisher Input Path Sensor was not deactivated within a specified time after the Finisher Input Path Sensor was actuated.

Step	Actions and Questions	Yes	No
1	<p><b>PATH LOCATION INSPECTION</b> Inspect the position of the sheet of paper exiting the Finisher Input Path Sensor. <b>Has the trail edge of the sheet of paper cleared the Finisher Input Path Sensor?</b></p>	Go to step 2	Go to step 5

## 4025-Finisher

Step	Actions and Questions	Yes	No
2	<p><b>SENSOR TEST</b> Enter Diagnostics and check the Finisher Input Path Sensor function. <b>Does the Finisher Input Path Sensor test ok?</b></p>	Go to step 4	Go to step 3
3	<p><b>FINISHER INPUT PATH SENSOR</b> Replace the Finisher Input Path Sensor. Go to <b>“Sensor, Input Path Removal” on page 4-41</b>. Enter Diagnostics and check the Finisher Input Path Sensor function. Insert then remove a sheet of paper into the sensor. <b>Does the Operator Panel LCD change between OP and CL as you insert then remove the paper?</b></p>	Problem solved	Go to step 4
4	<p><b>FINISHER MAIN BOARD</b> Replace the Finisher Main Board. Go to <b>“PWB Assembly-Main Removal” on page 4-132</b>. Enter Diagnostics and check the Finisher Input Path Sensor function. Insert then remove a sheet of paper into the sensor. <b>Does the Operator Panel LCD change between OP and CL as you insert then remove the paper?</b></p>	Problem solved	Replace the MCU Board
5	<p><b>PATH PAPER INSPECTION</b> Inspect the Drive Rolls in the Finisher, especially the Input Rolls and the Registration Rolls. <b>Are all of the Drive Rolls in the Finisher clean and free of obvious wear and damage?</b></p>	Go to step 6	Replace the suspect Drive Rolls
6	<p><b>DRIVE TRAIN TEST</b> Enter Diagnostics and select Output Bin Tests. Select Feed Test, Output Bin 2 to run the Finisher Main Feed Motor. <b>Does the Finisher Main Feed Motor run smoothly?</b></p>	Go to step 7	Replace the Finisher Main Feed Motor
7	<p><b>DRIVE TRAIN INSPECTION</b> Inspect the drive train, including belts, pulleys, and gears, of the entire Finisher Assembly from the Finisher Main Feed Motor to the Registration Rolls. <b>Does the entire drive train of the Finisher Assembly appear to be in good condition, with no damaged or slipping belts and no chipped or broken pulleys or gears?</b></p>	Go to step 8	Replace the suspect belts, pulleys, and gears
8	<p>The following Finisher FRUs and areas are associated with this specific problem. One or more of these FRUs or areas may have failed partially or completely. If you cannot isolate this problem using these steps, replace each FRU or troubleshoot each area listed below, one at a time, until you isolate and solve the problem.</p> <ul style="list-style-type: none"> <li>• Wiring and connectors linking the FRUs</li> <li>• H-Tra drive train FRUs, including gear, belts, and rolls.</li> </ul>		

## 286 - Attendance Message

Logic Control sensed that the Finisher Input Path Sensor was not actuated within the specified time after the H-Tra Exit Sensor was deactivated.

Step	Actions and Questions	Yes	No
1	<p><b>PATH LOCATION INSPECTION</b> Inspect the position of the sheet of paper on the H-Tra. <b>Has the lead edge of the sheet of paper actuated the Finisher Input Path Sensor?</b></p>	Go to step 2	Go to step 5
2	<p><b>SENSOR TEST</b> Enter Diagnostics and check the Finisher Input Path Sensor function. Insert then remove a sheet of paper into the sensor. <b>Does the Operator Panel LCD change between OP and CL as you insert then remove the paper?</b></p>	Go to step 4	Go to step 3
3	<p><b>FINISHER INPUT PATH SENSOR</b> Replace the Finisher Input Path Sensor. Go to <b>“Sensor, Input Path Removal” on page 4-41</b>. Enter Diagnostics and check the Finisher Input Path Sensor function. Insert then remove a sheet of paper into the sensor. <b>Does the Operator Panel LCD change between OP and CL as you insert then remove the paper?</b></p>	Problem solved	Go to step 4
4	<p><b>FINISHER MAIN BOARD</b> Replace the Finisher Main Board. Go to <b>“PWB Assembly-Main Removal” on page 4-132</b>. Enter Diagnostics and check the Finisher Input Path Sensor function. Insert then remove a sheet of paper into the sensor. <b>Does the Operator Panel LCD change between OP and CL as you insert then remove the paper?</b></p>	Problem solved	Replace the MCU Board
5	<p><b>PATH PAPER INSPECTION</b> Inspect the Drive Rolls in the Finisher, especially the Input Rolls and the Registration Rolls. <b>Are all of the Drive Rolls in the Finisher clean and free of obvious wear and damage?</b></p>	Go to step 6	Replace the suspect Drive Rolls
6	<p><b>DRIVE TRAIN TEST</b> Enter Diagnostics and select Output Bin Tests. Select Feed Test, Output Bin 2 to run the Finisher Main Feed Motor. <b>Does the Finisher Main Feed Motor run smoothly?</b></p>	Go to step 7	Replace the Finisher Main Feed Motor
7	<p><b>DRIVE TRAIN INSPECTION</b> Inspect the drive train, including belts, pulleys, and gears, of the entire Finisher Assembly from the Finisher Main Feed Motor to the Registration Rolls. <b>Does the entire drive train of the Finisher Assembly appear to be in good condition, with no damaged or slipping belts and no chipped or broken pulleys or gears?</b></p>	Go to step 8	Replace the suspect belts, pulleys, and gears

## 4025-Finisher

Step	Actions and Questions	Yes	No
8	<p>The following Finisher FRUs and areas are associated with this specific problem. One or more of these FRUs or areas may have failed partially or completely. If you cannot isolate this problem using these steps, replace each FRU or troubleshoot each area listed below, one at a time, until you isolate and solve the problem.</p> <ul style="list-style-type: none"> <li>• Wiring and connectors linking the FRUs</li> <li>• H-Tra drive train FRUs, including gear, belts, and rolls.</li> </ul>		

### 287 - Attendance Message

Logic Control sensed that the H-Tra Input Sensor was not actuated within a specified time after the Fuser Exit Sensor was deactivated.

Step	Actions and Questions	Yes	No
1	<p><b>PATH LOCATION INSPECTION</b> Inspect the position of the sheet of paper entering the H-Tra. <b>Has the lead edge of the sheet of paper actuated the H-Tra Input Sensor?</b></p>	Go to step 5	Go to step 2
2	<p><b>H-TRA GATE SOLENOID TEST</b> Enter Diagnostics and check the H-Tra Gate Solenoid function. Insert then remove a sheet of paper into the sensor. <b>Does the Operator Panel LCD change between OP and CL as you insert then remove the paper?</b></p>	Go to step 3	Go to step 7
3	<p><b>H-TRA GATE INSPECTION</b> Inspect the H-Tra Gate for damage. <b>Is the H-Tra Gate in good condition and does the H-Tra Gate move when you actuate the H-Tra Gate Solenoid?</b></p>	Go to step 4	Replace the H-Tra Gate
4	<p><b>FINISHER MAIN BOARD</b> Replace the Finisher Main Board. Go to <b>“PWB Assembly-Main Removal” on page 4-132</b>. Enter Diagnostics and check the H-Tra Gate Solenoid function. Insert then remove a sheet of paper into the sensor. <b>Does the Operator Panel LCD change between OP and CL as you insert then remove the paper?</b></p>	Problem solved	Replace the MCU Board
5	<p><b>SENSOR TEST</b> Enter Diagnostics and check the H-Tra Input Sensor function. Insert then remove a sheet of paper into the sensor. <b>Does the Operator Panel LCD change between OP and CL as you insert then remove the paper?</b></p>	Go to step 8	Go to step 6



## 4025-Finisher

Step	Actions and Questions	Yes	No
6	<b>H-TRA INPUT SENSOR</b> Replace the H-Tra Input Sensor. Go to <b>“Sensors Removal” on page 4-20</b> . Enter Diagnostics and check the H-Tra Input Sensor function. Insert then remove a sheet of paper into the sensor. <b>Does the Operator Panel LCD change between OP and CL as you insert then remove the paper?</b>	Problem solved	Go to step 8
7	<b>H-TRA GATE SOLENOID</b> Replace the H-Tra Gate Solenoid. Enter Diagnostics and check the H-Tra Gate Solenoid function. Insert then remove a sheet of paper into the sensor. <b>Does the Operator Panel LCD change between OP and CL as you insert then remove the paper?</b>	Problem solved	Go to step 8
8	<b>FINISHER MAIN BOARD</b> Replace the Finisher Main Board. Enter Diagnostics and check the H-Tra Input Sensor function. Insert then remove a sheet of paper into the sensor. <b>Does the Operator Panel LCD change between OP and CL as you insert then remove the paper?</b>	Problem solved	Go to step 9
9	<b>MCU BOARD</b> Replace the MCU Board. Refer to the Printer Service Manual. Enter Diagnostics and check the H-Tra Input Sensor function. <b>Does the H-Tra Input Sensor test ok?</b>	Problem solved	

### 288 - Attendance Message

Logic Control sensed that the Finisher Path Sensor did not deactuate within the specified time after it was actuated.

Step	Actions and Questions	Yes	No
1	<b>PATH LOCATION INSPECTION</b> Inspect the position of the sheet of paper in the Finisher. <b>Has the trail edge of the sheet of paper cleared the Finisher Path Sensor?</b>	Go to step 2	Go to step 5
2	<b>SENSOR TEST</b> Enter Diagnostics and check the Finisher Path Sensor function. Insert then remove a sheet of paper into the sensor. <b>Does the Operator Panel LCD change between OP and CL as you insert then remove the paper?</b>	Go to step 4	Go to step 3

## 4025-Finisher

Step	Actions and Questions	Yes	No
3	<p><b>FINISHER PATH SENSOR</b>                      Replace the Finisher Path Sensor. Go to <b>“Sensor, Input Path Removal” on page 4-41</b>. Enter Diagnostics and check the Finisher Path Sensor function. Insert then remove a sheet of paper into the sensor.  <b>Does the Operator Panel LCD change between OP and CL as you insert then remove the paper?</b></p>	Problem solved	Go to step 4
4	<p><b>FINISHER MAIN BOARD</b>                      Replace the Finisher Main Board. Go to <b>“PWB Assembly-Main Removal” on page 4-132</b>. Enter Diagnostics and check the Finisher Path Sensor function. Insert then remove a sheet of paper into the sensor.  <b>Does the Operator Panel LCD change between OP and CL as you insert then remove the paper?</b></p>	Problem solved	Replace the MCU Board
5	<p><b>PATH PAPER INSPECTION</b>                      Inspect the Drive Rolls in the Finisher, especially the Input Rolls and the Registration Rolls.  <b>Are all of the Drive Rolls in the Finisher clean and free of obvious wear and damage?</b></p>	Go to step 6	Replace the suspect Drive Rolls
6	<p><b>DRIVE TRAIN TEST</b>                      Enter Diagnostics and select Output Bin Tests. Select Feed Test, Output Bin 2 to run the Finisher Main Feed Motor.  <b>Does the Finisher Main Feed Motor run smoothly?</b></p>	Go to step 7	Replace the Finisher Main Feed Motor
7	<p><b>DRIVE TRAIN INSPECTION</b>                      Inspect the drive train, including belts, pulleys, and gears, of the entire Finisher Assembly from the Finisher Main Feed Motor to the Registration Rolls.  <b>Does the entire drive train of the Finisher Assembly appear to be in good condition, with no damaged or slipping belts and no chipped or broken pulleys or gears?</b></p>	Go to step 8	Replace the suspect belts, pulleys, and gears
8	<p>The following Finisher FRUs and areas are associated with this specific problem. One or more of these FRUs or areas may have failed partially or completely. If you cannot isolate this problem using these steps, replace each FRU or troubleshoot each area listed below, one at a time, until you isolate and solve the problem.</p> <ul style="list-style-type: none"> <li>• Wiring and connectors linking the FRUs</li> </ul>		

## 289 - Attendance Message

Logic control sensed that the Finisher Path Sensor was not actuated within the specified time after the Finisher Input Sensor was actuated.

Step	Actions and Questions	Yes	No
1	<b>PATH LOCATION INSPECTION</b> Inspect the position of the sheet of paper in the Finisher. <b>Has the lead edge of the sheet of paper actuated the Finisher Path Sensor?</b>	Go to step 2	Go to step 5
2	<b>SENSOR TEST</b> Enter Diagnostics and check the Finisher Path Sensor function. Insert then remove a sheet of paper into the sensor. <b>Does the Operator Panel LCD change between OP and CL as you insert then remove the paper?</b>	Go to step 4	Go to step 3
3	<b>FINISHER PATH SENSOR</b> Replace the Finisher Path Sensor. Go to <b>“Sensor, Input Path Removal” on page 4-41</b> . Enter Diagnostics and check the Finisher Path Sensor function. Insert then remove a sheet of paper into the sensor. <b>Does the Operator Panel LCD change between OP and CL as you insert then remove the paper?</b>	Problem solved	Go to step 4
4	<b>FINISHER MAIN BOARD</b> Replace the Finisher Main Board. Go to <b>“PWB Assembly-Main Removal” on page 4-132</b> . Enter Diagnostics and check the Finisher Path Sensor function. Insert then remove a sheet of paper into the sensor. <b>Does the Operator Panel LCD change between OP and CL as you insert then remove the paper?</b>	Problem solved	Replace the MCU Board
5	<b>PATH PAPER INSPECTION</b> Inspect the Drive Rolls in the Finisher, especially the Input Rolls and the Registration Rolls. <b>Are all of the Drive Rolls in the Finisher clean and free of obvious wear and damage?</b>	Go to step 6	Replace the suspect Drive Rolls
6	<b>DRIVE TRAIN TEST</b> Enter Diagnostics and select Output Bin Tests. Select Feed Test, Output Bin 2 to run the Finisher Main Feed Motor. <b>Does the Finisher Main Feed Motor run smoothly?</b>	Go to step 7	Replace the Finisher Main Feed Motor
7	<b>DRIVE TRAIN INSPECTION</b> Inspect the drive train, including belts, pulleys, and gears, of the entire Finisher Assembly from the Finisher Main Feed Motor to the Registration Rolls. <b>Does the entire drive train of the Finisher Assembly appear to be in good condition, with no damaged or slipping belts and no chipped or broken pulleys or gears?</b>	Go to step 8	Replace the suspect belts, pulleys, and gears

## 4025-Finisher

Step	Actions and Questions	Yes	No
8	<p>The following Finisher FRUs and areas are associated with this specific problem. One or more of these FRUs or areas may have failed partially or completely. If you cannot isolate this problem using these steps, replace each FRU or troubleshoot each area listed below, one at a time, until you isolate and solve the problem.</p> <ul style="list-style-type: none"> <li>• Wiring and connectors linking the FRUs</li> </ul>		

### 290 - Attendance Message

Logic Control sensed that the Finisher Exit Path Sensor did not deactuate within the specified time after it was actuated.

Step	Actions and Questions	Yes	No
1	<p><b>PATH LOCATION INSPECTION</b> Inspect the position of the sheet of paper in the Finisher. <b>Has the trail edge of the sheet of paper cleared the Finisher Exit Path Sensor?</b></p>	Go to step 2	Go to step 5
2	<p><b>SENSOR TEST</b> Enter Diagnostics and check the Finisher Exit Path Sensor function. Insert then remove a sheet of paper into the sensor. <b>Does the Operator Panel LCD change between OP and CL as you insert then remove the paper?</b></p>	Go to step 4	Go to step 3
3	<p><b>FINISHER EXIT PATH SENSOR</b> Replace the Finisher Exit Path Sensor. Go to <b>“Sensor, Input Path Removal” on page 4-41</b>. Enter Diagnostics and check the Finisher Exit Path Sensor function. Insert then remove a sheet of paper into the sensor. <b>Does the Operator Panel LCD change between OP and CL as you insert then remove the paper?</b></p>	Problem solved	Go to step 4
4	<p><b>FINISHER MAIN BOARD</b> Replace the Finisher Main Board. Go to <b>“PWB Assembly-Main Removal” on page 4-132</b>. Enter Diagnostics and check the Finisher Exit Path Sensor function. Insert then remove a sheet of paper into the sensor. <b>Does the Operator Panel LCD change between OP and CL as you insert then remove the paper?</b></p>	Problem solved	Replace the MCU Board
5	<p><b>PATH PAPER INSPECTION</b> Inspect the Drive Rolls in the Finisher, especially the Registration Rolls, Shift Rolls, and Exit Rolls. <b>Are all of the Drive Rolls in the Finisher clean and free of obvious wear and damage?</b></p>	Go to step 6	Replace the suspect Drive Rolls

## 4025-Finisher

Step	Actions and Questions	Yes	No
6	<p><b>DRIVE TRAIN TEST</b> Enter Diagnostics and select Output Bin Tests. Select Feed Test, Output Bin 2 to run the Finisher Main Feed Motor. <b>Does the Finisher Main Feed Motor run smoothly?</b></p>	Go to step 7	Replace the Finisher Main Feed Motor
7	<p><b>DRIVE TRAIN INSPECTION</b> Inspect the drive train, including belts, pulleys, and gears, of the entire Finisher Assembly from the Finisher Main Feed Motor, through the Shift Rolls, and on to the Exit Rolls. <b>Does the entire drive train of the Finisher Assembly appear to be in good condition, with no damaged or slipping belts and no chipped or broken pulleys or gears?</b></p>	Go to step 8	Replace the suspect belts, pulleys, and gears
8	<p>The following Finisher FRUs and areas are associated with this specific problem. One or more of these FRUs or areas may have failed partially or completely. If you cannot isolate this problem using these steps, replace each FRU or troubleshoot each area listed below, one at a time, until you isolate and solve the problem.</p> <ul style="list-style-type: none"> <li>• Shift Roll Unit</li> <li>• Wiring and connectors linking the FRUs</li> </ul>		

### 291 - Attendance Message

Logic Control sensed that the Finisher Exit Path Sensor was not actuated within the specified time after the Finisher Path Sensor was actuated.

Step	Actions and Questions	Yes	No
1	<p><b>PATH LOCATION INSPECTION</b> Inspect the position of the sheet of paper in the Finisher. <b>Has the leading edge of the sheet of paper actuated the Finisher Exit Path Sensor?</b></p>	Go to step 2	Go to step 5
2	<p><b>SENSOR TEST</b> Enter Diagnostics and check the Finisher Exit Path Sensor function. Insert then remove a sheet of paper into the sensor. <b>Does the Operator Panel LCD change between OP and CL as you insert then remove the paper?</b></p>	Go to step 4	Go to step 3
3	<p><b>FINISHER EXIT PATH SENSOR</b> Replace the Finisher Exit Path Sensor. Enter Diagnostics and check the Finisher Exit Path Sensor function. Insert then remove a sheet of paper into the sensor. <b>Does the Operator Panel LCD change between OP and CL as you insert then remove the paper?</b></p>	Problem solved	Go to step 4

## 4025-Finisher

Step	Actions and Questions	Yes	No
4	<p><b>FINISHER MAIN BOARD</b>                      Replace the Finisher Main Board. Go to <b>“PWB Assembly-Main Removal” on page 4-132</b>. Enter Diagnostics and check the Finisher Exit Path Sensor function. Insert then remove a sheet of paper into the sensor.  <b>Does the Operator Panel LCD change between OP and CL as you insert then remove the paper?</b></p>	Problem solved	Replace the MCU Board
5	<p><b>PATH PAPER INSPECTION</b>                      Inspect the Drive Rolls in the Finisher, especially the Input Rolls and the Registration Rolls.  <b>Are all of the Drive Rolls in the Finisher clean and free of obvious wear and damage?</b></p>	Go to step 6	Replace the suspect Drive Rolls
6	<p><b>DRIVE TRAIN TEST</b>                      Enter Diagnostics and select Output Bin Tests. Select Feed Test, Output Bin 2 to run the Finisher Main Feed Motor.  <b>Does the Finisher Main Feed Motor run smoothly?</b></p>	Go to step 7	Replace the Finisher Main Feed Motor
7	<p><b>DRIVE TRAIN INSPECTION</b>                      Inspect the drive train, including belts, pulleys, and gears, of the entire Finisher Assembly from the Finisher Main Feed Motor to the Registration Rolls.  <b>Does the entire drive train of the Finisher Assembly appear to be in good condition, with no damaged or slipping belts and no chipped or broken pulleys or gears?</b></p>	Go to step 8	Replace the suspect belts, pulleys, and gears
8	<p>The following Finisher FRUs and areas are associated with this specific problem. One or more of these FRUs or areas may have failed partially or completely. If you cannot isolate this problem using these steps, replace each FRU or troubleshoot each area listed below, one at a time, until you isolate and solve the problem.</p> <ul style="list-style-type: none"> <li>• Wiring and connectors linking the FRUs</li> </ul>		

### 292 - Attendance Message

Logic Control sensed that the Exit Roll Interlock Switch is actuated.

Step	Actions and Questions	Yes	No
1	<p><b>EXIT ROLL INTERLOCK INSPECTION</b>                      Remove the Top Covers and inspect the Exit Roll Unit and the area around the Exit Roll Interlock Switch.  <b>Is the Exit Roll Unit in good condition and is the area clear of obvious damage?</b></p>	Go to step 2	Replace the suspect FRUs

## 4025-Finisher

Step	Actions and Questions	Yes	No
2	<b>INTERLOCK TEST</b> Enter Diagnostics and check the Exit Roll Interlock Switch function. Insert then remove a sheet of paper into the sensor. <b>Does the Operator Panel LCD change between OP and CL as you insert then remove the paper?</b>	Go to step 4	Go to step 3
3	<b>EXIT ROLL INTERLOCK SWITCH</b> Replace the Exit Roll Interlock Switch. Go to <b>“Exit Assembly Removal” on page 4-145</b> . Enter Diagnostics and check the Exit Roll Interlock Switch function. Insert then remove a sheet of paper into the sensor. <b>Does the Operator Panel LCD change between OP and CL as you insert then remove the paper?</b>	Problem solved	Go to step 4
4	<b>FINISHER MAIN BOARD</b> Replace the Finisher Main Board. Go to <b>“PWB Assembly-Main Removal” on page 4-132</b> . Enter Diagnostics and check the Exit Roll Interlock Switch function. Insert then remove a sheet of paper into the sensor. <b>Does the Operator Panel LCD change between OP and CL as you insert then remove the paper?</b>	Problem solved	Go to step 5
5	<b>MCU BOARD</b> Replace the MCU Board. Refer to the Printer Service Manual. Enter Diagnostics and check the Exit Roll Interlock Switch function. <b>Does the Exit Roll Interlock Switch test ok?</b>	Problem solved	Go to step 6
6	The following Finisher FRUs and areas are associated with this specific problem. One or more of these FRUs or areas may have failed partially or completely. If you cannot isolate this problem using these steps, replace each FRU or troubleshoot each area listed below, one at a time, until you isolate and solve the problem.  • Wiring and connectors linking the FRUs		

### 295 - Attendance Message

Logic control sensed that either the Compiler Tray Paper Sensor did not deactivate within the specified time after the set started to output, or the Compiler Tray Paper Sensor did not deactivate within the specified time after the Sensor was actuated.

Step	Actions and Questions	Yes	No
1	<b>PATH LOCATION INSPECTION</b> Inspect the position of the sheet of paper exiting the Compiler Tray. <b>Has the trail edge of the sheet of paper cleared the Compiler Tray Paper Sensor?</b>	Go to step 2	Go to step 5

4025-Finisher

Step	Actions and Questions	Yes	No
2	<p><b>SENSOR TEST</b>            Enter Diagnostics and check the Compiler Tray Paper Sensor function. Insert then remove a sheet of paper into the sensor.  <b>Does the Operator Panel LCD change between OP and CL as you insert then remove the paper?</b></p>	Go to step 4	Go to step 3
3	<p><b>COMPILER TRAY PAPER SENSOR</b>            Replace the Compiler Tray Paper Sensor. Go to <b>“Compiler Roll and Roll Shaft Removal” on page 4-80</b>. Enter Diagnostics and check the Compiler Tray Paper Sensor function. Insert then remove a sheet of paper into the sensor.  <b>Does the Operator Panel LCD change between OP and CL as you insert then remove the paper?</b></p>	Problem solved	Go to step 4
4	<p><b>FINISHER MAIN BOARD</b>            Replace the Finisher Main Board. Go to <b>“PWB Assembly-Main Removal” on page 4-132</b>. Enter Diagnostics and check the Compiler Tray Paper Sensor function. Insert then remove a sheet of paper into the sensor.  <b>Does the Operator Panel LCD change between OP and CL as you insert then remove the paper?</b></p>	Problem solved	Replace the MCU Board
5	<p><b>PATH PAPER INSPECTION</b>            Inspect the Exit Rolls in the Compiler.  <b>Are all of the Exit Rolls in the Compiler clean and free of obvious wear and damage?</b></p>	Go to step 6	Replace the suspect Rolls
6	<p><b>DRIVE TRAIN TEST</b>            Enter Diagnostics and select Output Bin Tests. Select Feed Test, Output Bin 2 to run the Finisher Main Feed Motor.  <b>Does the Finisher Main Feed Motor run smoothly?</b></p>	Go to step 7	Replace the Finisher Main Feed Motor
7	<p><b>DRIVE TRAIN INSPECTION</b>            Inspect the drive train, including belts, pulleys, and gears, of the entire Finisher Assembly from the Finisher Main Feed Motor to the Compiler Exit Rolls.  <b>Does the entire drive train of the Finisher Assembly appear to be in good condition, with no damaged or slipping belts and no chipped or broken pulleys or gears?</b></p>	Go to step 8	Replace the suspect belts, pulleys, and gears
8	<p>The following Finisher FRUs and areas are associated with this specific problem. One or more of these FRUs or areas may have failed partially or completely. If you cannot isolate this problem using these steps, replace each FRU or troubleshoot each area listed below, one at a time, until you isolate and solve the problem.</p> <ul style="list-style-type: none"> <li>• Wiring and connectors linking the FRUs</li> <li>• Compiler Tray and Compiler Move Tray</li> </ul>		



## Service Error Code Service Checks

### 980 - Error Code Service Check

Logic control sensed that there is a communication problem between the printer and the Finisher.

Step	Actions and Questions	Yes	No
1	<b>RESET</b> Switch off the printer and the Finisher. Wait one minute, then switch on the printer and the Finisher <b>Is the error code gone?</b>	Problem solved	Go to step 2
2	<b>RESEAT</b> Disconnect then reconnect the Finisher from the printer. <b>Is the error code gone?</b>	Problem solved	Go to step 3
3	<b>FINISHER MAIN BOARD</b> Replace the Finisher Main Board. Go to <b>“PWB Assembly-Main Removal” on page 4-132</b> . Check the Stapler function. <b>Does the Stapler function correctly?</b>	Problem solved	Go to step 4
4	<b>MCU BOARD</b> Replace the MCU Board. Refer to the Printer Service Manual. Check the Stapler function. <b>Does the Stapler function correctly?</b>	Problem solved	Go to step 5
5	The following Finisher FRUs and areas are associated with this specific problem. One or more of these FRUs or areas may have failed partially or completely. If you cannot isolate this problem using these steps, replace each FRU or troubleshoot each area listed below, one at a time, until you isolate and solve the problem.  • Wiring and connectors linking the FRUs		

### 981 - Stacker Tray Service Check

Logic control sensed that there is a problem with the Stacker Tray.

Step	Actions and Questions	Yes	No
1	<b>STACKER TRAY INSPECTION</b> Inspect the position of the Stacker Tray. <b>Has the Tray actuated the Stacker Height Sensor?</b>	Go to step 3	Go to step 2
2	<b>SENSOR TEST</b> Enter Diagnostics and check the Stacker Tray Position Sensor function. Insert then remove a sheet of paper into the sensor. <b>Does the Operator Panel LCD change between OP and CL as you insert then remove the paper?</b>	Go to step 4	Go to step 3

## 4025-Finisher

Step	Actions and Questions	Yes	No
3	<p><b>ENCODER ASSEMBLY</b></p> <p>Replace the Encoder Assembly. Enter Diagnostics and check the Stacker Tray Position Sensor function. Insert then remove a sheet of paper into the sensor.</p> <p><b>Does the Operator Panel LCD change between OP and CL as you insert then remove the paper?</b></p>	Problem solved	Go to step 4
4	<p><b>FINISHER MAIN BOARD</b></p> <p>Replace the Finisher Main Board. Go to <b>“PWB Assembly-Main Removal” on page 4-132</b>. Enter Diagnostics and check the Docking Interlock Switch function.</p> <p><b>Does the Interlock Switch test ok?</b></p>	Problem solved	Go to step 5
5	<p><b>MCU BOARD</b></p> <p>Replace the MCU Board. Refer to the Printer Service Manual. Enter Diagnostics and check the Docking Interlock Switch function.</p> <p><b>Does the Interlock Switch test ok?</b></p>	Problem solved	Go to step 6
6	<p>The following Finisher FRUs and areas are associated with this specific problem. One or more of these FRUs or areas may have failed partially or completely. If you cannot isolate this problem using these steps, replace each FRU or troubleshoot each area listed below, one at a time, until you isolate and solve the problem.</p> <ul style="list-style-type: none"> <li>• Wiring and connectors linking the FRUs</li> <li>• Elevator Drive Unit</li> <li>• Elevator Belt</li> <li>• Stacker Tray</li> <li>• Stacker Tray Paper Sensor</li> </ul>		

### 982 - Error Code Service Check

Logic control sensed that there is a problem at the Jogger Home F Sensor.

Step	Actions and Questions	Yes	No
1	<p><b>SENSOR TEST</b></p> <p>Enter Diagnostics and check the Jogger Home F Sensor function. Insert then remove a sheet of paper into the sensor.</p> <p><b>Does the Operator Panel LCD change between OP and CL as you insert then remove the paper?</b></p>	Go to step 3	Go to step 2

## 4025-Finisher

Step	Actions and Questions	Yes	No
2	<p><b>JOGGER HOME POSITION SENSOR</b>                      Replace the Jogger Home Position Sensor. Go to <b>“Sensor, Jogger Home Position Removal” on page 4-68</b>. Enter Diagnostics and check the Jogger Home F Sensor function. Insert then remove a sheet of paper into the sensor.  <b>Does the Operator Panel LCD change between OP and CL as you insert then remove the paper?</b></p>	Problem solved	Go to step 3
3	<p><b>FINISHER MAIN BOARD</b>                      Replace the Finisher Main Board. Go to <b>“PWB Assembly-Main Removal” on page 4-132</b>. Enter Diagnostics and check the Jogger Home F Sensor function. Insert then remove a sheet of paper into the sensor.  <b>Does the Operator Panel LCD change between OP and CL as you insert then remove the paper?</b></p>	Problem solved	Go to step 4
4	<p><b>MCU BOARD</b>                      Replace the MCU Board. Refer to the Printer Service Manual. Enter Diagnostics and check the Jogger Home F Sensor function. Insert then remove a sheet of paper into the sensor.  <b>Does the Operator Panel LCD change between OP and CL as you insert then remove the paper?</b></p>	Problem solved	Go to step 5
5	<p>The following Finisher FRUs and areas are associated with this specific problem. One or more of these FRUs or areas may have failed partially or completely. If you cannot isolate this problem using these steps, replace each FRU or troubleshoot each area listed below, one at a time, until you isolate and solve the problem.</p> <ul style="list-style-type: none"> <li>• Wiring and connectors linking the FRUs</li> <li>• FRUs within the Jogger Assembly</li> </ul>		

### 983 - Error Code Service Check

Logic control sensed that there is a problem at the Jogger Home R Sensor.

Step	Actions and Questions	Yes	No
1	<p><b>SENSOR TEST</b>                      Enter Diagnostics and check the Jogger Home R Sensor function. Insert then remove a sheet of paper into the sensor.  <b>Does the Operator Panel LCD change between OP and CL as you insert then remove the paper?</b></p>	Go to step 3	Go to step 2

## 4025-Finisher

Step	Actions and Questions	Yes	No
2	<p><b>JOGGER HOME POSITION SENSOR</b>                      Replace the Jogger Home Position Sensor. Go to <b>“Sensor, Jogger Home Position Removal” on page 4-68</b>. Enter Diagnostics and check the Jogger Home R Sensor function. Insert then remove a sheet of paper into the sensor.  <b>Does the Operator Panel LCD change between OP and CL as you insert then remove the paper?</b></p>	Problem solved	Go to step 3
3	<p><b>FINISHER MAIN BOARD</b>                      Replace the Finisher Main Board. Go to <b>“PWB Assembly-Main Removal” on page 4-132</b>. Enter Diagnostics and check the Jogger Home R Sensor function. Insert then remove a sheet of paper into the sensor.  <b>Does the Operator Panel LCD change between OP and CL as you insert then remove the paper?</b></p>	Problem solved	Go to step 4
4	<p><b>MCU BOARD</b>                      Replace the MCU Board. Refer to the Printer Service Manual. Enter Diagnostics and check the Jogger Home R Sensor function. Insert then remove a sheet of paper into the sensor.  <b>Does the Operator Panel LCD change between OP and CL as you insert then remove the paper?</b></p>	Problem solved	Go to step 5
5	<p>The following Finisher FRUs and areas are associated with this specific problem. One or more of these FRUs or areas may have failed partially or completely. If you cannot isolate this problem using these steps, replace each FRU or troubleshoot each area listed below, one at a time, until you isolate and solve the problem.</p> <ul style="list-style-type: none"> <li>• Wiring and connectors linking the FRUs</li> <li>• FRUs within the Jogger Assembly</li> </ul>		

### 984 - Error Code Service Check

Logic control sensed that there is a problem at the Exit Roll.

Step	Actions and Questions	Yes	No
1	<p><b>SENSOR TEST</b>                      Enter Diagnostics and check the Exit Roll Open/Close HP Sensor. Insert then remove a sheet of paper into the sensor.  <b>Does the Operator Panel LCD change between OP and CL as you insert then remove the paper?</b></p>	Go to step 3	Go to step 2

## 4025-Finisher

Step	Actions and Questions	Yes	No
2	<p><b>EXIT ROLL OPEN/CLOSE HP SENSOR</b>                      Replace the Exit Roll Open/Close HP Sensor. Go to <b>“Motor Removal” on page 4-84</b>. Enter Diagnostics and check the Exit Roll Open/Close HP Sensor. Insert then remove a sheet of paper into the sensor.  <b>Does the Operator Panel LCD change between OP and CL as you insert then remove the paper?</b></p>	Problem solved	Go to step 6
3	<p><b>MOTOR TEST</b>                      Enter Diagnostics and select Output Bin Tests. Select Feed Test, Output Bin 2 to feed paper through the Finisher.  <b>Does the Exit Roll Open/Close Motor test ok?</b></p>	Go to step 5	Go to step 4
4	<p><b>EXIT ROLL OPEN/CLOSE MOTOR</b>                      Replace the Exit Roll Open/Close Motor. Go to <b>“Motor Removal” on page 4-84</b>. Exit Roll Open/Close Motor function.  <b>Does the Exit Roll Open/Close Motor test ok?</b></p>	Problem solved	Go to step 6
5	<p><b>DRIVE TRAIN INSPECTION</b>                      Inspect the drive train, including belts, gears, and levers of the entire Exit Roll Assembly.  <b>Does the entire drive train of the Exit Roll Assembly appear to be in good condition, with no damaged or slipping gears and no broken levers?</b></p>	Go to step 6	Replace the damaged FRUs
6	<p><b>FINISHER MAIN BOARD</b>                      Replace the Finisher Main Board. Go to <b>“PWB Assembly-Main Removal” on page 4-132</b>. Enter Diagnostics and check the Exit Roll Open/Close HP Sensor. Insert then remove a sheet of paper into the sensor.  <b>Does the Operator Panel LCD change between OP and CL as you insert then remove the paper?</b></p>	Problem solved	Go to step 7
7	<p><b>MCU BOARD</b>                      Replace the MCU Board. Refer to the Printer Service Manual. Enter Diagnostics and check the Exit Roll Open/Close HP Sensor.  <b>Does the Exit Roll Open/Close HP Sensor test ok?</b></p>	Problem solved	Go to step 8
8	<p>The following Finisher FRUs and areas are associated with this specific problem. One or more of these FRUs or areas may have failed partially or completely. If you cannot isolate this problem using these steps, replace each FRU or troubleshoot each area listed below, one at a time, until you isolate and solve the problem.</p> <ul style="list-style-type: none"> <li>• Wiring and connectors linking the FRUs</li> <li>• Broken or damaged FRUs within the Exit Roll area.</li> </ul>		

## 985 - Error Code Service Check

Logic control sensed that the Shift Roller failed.

Step	Actions and Questions	Yes	No
1	<p><b>SENSOR TEST</b> Enter Diagnostics and check the Shift Roller HP Sensor function. Insert then remove a sheet of paper into the sensor. <b>Does the Operator Panel LCD change between OP and CL as you insert then remove the paper?</b></p>	Go to step 3	Go to step 2
2	<p><b>SHIFT ROLLER HP SENSOR</b> Replace the Shift Roller HP Sensor. Go to <b>“No Paper Sensor Assembly Removal” on page 4-136</b>. Enter Diagnostics and check the Shift Roller HP Sensor function. Insert then remove a sheet of paper into the sensor. <b>Does the Operator Panel LCD change between OP and CL as you insert then remove the paper?</b></p>	Problem solved	Go to step 6
3	<p><b>MOTOR TEST</b> Enter Diagnostics and select Output Bin Tests. Select Feed Test, Output Bin 2 to feed paper through the Finisher. <b>Does the Shift Motor test ok?</b></p>	Go to step 5	Go to step 4
4	<p><b>SHIFT MOTOR</b> Replace the Shift Motor. Go to <b>“Motor Assembly-MP2 Removal” on page 4-77</b>. Enter Diagnostics and check the Shift Motor function. <b>Does the Shift Motor test ok?</b></p>	Problem solved	Go to step 6
5	<p><b>DRIVE TRAIN INSPECTION</b> Inspect the drive train, including belts, gears, and levers of the entire Shift Roller Assembly. <b>Does the entire drive train of the Shift Roller assembly appear to be in good condition, with no damaged or slipping gears and no broken levers?</b></p>	Go to step 6	Replace the damaged FRUs
6	<p><b>FINISHER MAIN BOARD</b> Replace the Finisher Main Board. Go to <b>“PWB Assembly-Main Removal” on page 4-132</b>. Enter Diagnostics and select Output Bin Tests. Select Feed Test, Output Bin 2 to feed paper through the Finisher. <b>Does the Sensor and/or Motor test ok?</b></p>	Problem solved	Go to step 7
7	<p><b>MCU BOARD</b> Replace the MCU Board. Refer to the Printer Service Manual. Enter Diagnostics and check the Shift Roller HP Sensor and/or Shift Motor function. <b>Does the Sensor and/or Motor test ok?</b></p>	Problem solved	Go to step 8

## 4025-Finisher

Step	Actions and Questions	Yes	No
8	<p>The following Finisher FRUs and areas are associated with this specific problem. One or more of these FRUs or areas may have failed partially or completely. If you cannot isolate this problem using these steps, replace each FRU or troubleshoot each area listed below, one at a time, until you isolate and solve the problem.</p> <ul style="list-style-type: none"> <li>• Wiring and connectors linking the FRUs.</li> <li>• Broken or damaged FRUs within the Shift Roll area.</li> </ul>		

## 986 - Error Code Service Check

Logic control sensed that the Punch failed.

Step	Actions and Questions	Yes	No
1	<p><b>SENSOR TEST</b> Enter Diagnostics and check the Finisher Path Sensor function. Insert then remove a sheet of paper into the sensor. <b>Does the Operator Panel LCD change between OP and CL as you insert then remove the paper?</b></p>	Go to step 3	Go to step 2
2	<p><b>FINISHER PATH SENSOR</b> Replace the Finisher Path Sensor. Enter Diagnostics and check the Finisher Path Sensor function. Insert then remove a sheet of paper into the sensor. <b>Does the Operator Panel LCD change between OP and CL as you insert then remove the paper?</b></p>	Problem solved	Go to step 6
3	<p><b>SENSOR TEST</b> Enter Diagnostics and check the Finisher Exit Path Sensor function. Insert then remove a sheet of paper into the sensor. <b>Does the Operator Panel LCD change between OP and CL as you insert then remove the paper?</b></p>	Go to step 5	Go to step 4
4	<p><b>FINISHER EXIT PATH SENSOR</b> Replace the Finisher Exit Path Sensor. Go to <b>“Sensor, Exit Path Removal” on page 4-42</b>. Enter Diagnostics and check the Finisher Exit Path Sensor function. Insert then remove a sheet of paper into the sensor. <b>Does the Operator Panel LCD change between OP and CL as you insert then remove the paper?</b></p>	Problem solved	Go to step 6
5	<p><b>PUNCH ASSEMBLY TEST</b> From the Finishing Menu, select Hole Punch On. From the Utilities Menu, select Quick Demo. <b>Does the Punch Assembly test ok?</b></p>	Go to step 6	Replace the Punch Assembly

## 4025-Finisher

Step	Actions and Questions	Yes	No
6	<p><b>FINISHER MAIN BOARD</b>                      Replace the Finisher Main Board. Go to <b>“PWB Assembly-Main Removal” on page 4-132</b>. Enter Diagnostics and check the Sensor and/or Punch Assembly function. Insert then remove a sheet of paper into the sensor.  <b>Does the Operator Panel LCD change between OP and CL as you insert then remove the paper?</b></p>	Problem solved	Go to step 7
7	<p><b>MCU BOARD</b>                      Replace the MCU Board. Refer to the Printer Service Manual. Enter Diagnostics and check the Sensor and/or Punch Assembly function.  <b>Does the Sensor and/or Punch Assembly test ok?</b></p>	Problem solved	Go to step 8
8	<p>The following Finisher FRUs and areas are associated with this specific problem. One or more of these FRUs or areas may have failed partially or completely. If you cannot isolate this problem using these steps, replace each FRU or troubleshoot each area listed below, one at a time, until you isolate and solve the problem.</p> <ul style="list-style-type: none"> <li>• Wiring and connectors linking the FRUs.</li> <li>• Broken or damaged FRUs within the Punch Assembly area or along the paper path.</li> </ul>		

### 987 - Error Code Service Check

Logic control sensed that the Stapler failed.

Step	Actions and Questions	Yes	No
1	<p><b>STAPLER INSPECTION</b>                      Inspect the Stapler for broken parts, jammed staples, or obvious signs of damage.  <b>Does the Stapler appear to be in good condition, with no jammed staples or obvious signs of damage?</b></p>	Go to step 2	Clear the staples or replace the damaged FRUs
2	<p><b>STAPLER CARTRIDGE</b>                      Replace the Stapler Cartridge. Go to <b>“Cartridge Removal” on page 4-101</b>.  <b>Does the Stapler function correctly?</b></p>	Problem solved	Go to step 3
3	<p><b>STAPLER ASSEMBLY</b>                      Replace the Stapler Assembly. Go to <b>“Stapler I Assembly Removal” on page 4-92</b>.  <b>Does the Stapler function correctly?</b></p>	Problem solved	Go to step 4



## 4025-Finisher

Step	Actions and Questions	Yes	No
4	<b>FINISHER MAIN BOARD</b> Replace the Finisher Main Board. Go to <b>“PWB Assembly-Main Removal” on page 4-132</b> . Check the Stapler function. <b>Does the Stapler function correctly?</b>	Problem solved	Go to step 5
5	<b>MCU BOARD</b> Replace the MCU Board. Refer to the Printer Service Manual. Check the Stapler function. <b>Does the Stapler function correctly?</b>	Problem solved	Go to step 6
6	The following Finisher FRUs and areas are associated with this specific problem. One or more of these FRUs or areas may have failed partially or completely. If you cannot isolate this problem using these steps, replace each FRU or troubleshoot each area listed below, one at a time, until you isolate and solve the problem. <ul style="list-style-type: none"> <li>• Wiring and connectors linking the FRUs</li> <li>• Broken or damaged FRUs within the Stapler area, Compiler area, or along the paper path.</li> </ul>		

## 988 - Error Code Service Check

Logic control sensed that there is a problem at the Stapler Head Home Sensor.

Step	Actions and Questions	Yes	No
1	<b>SENSOR TEST</b> Enter Diagnostics and check the Stapler Head Home Sensor function. Insert then remove a sheet of paper into the sensor. <b>Does the Operator Panel LCD change between OP and CL as you insert then remove the paper?</b>	Go to step 3	Go to step 2
2	<b>STAPLER HEAD HOME SENSOR</b> Replace the Stapler Head Home Sensor. Go to <b>“Sensor, Stapler Home Position Traverse Removal” on page 4-113</b> . Insert then remove a sheet of paper into the sensor. <b>Does the Operator Panel LCD change between OP and CL as you insert then remove the paper?</b>	Problem solved	Go to step 7
3	<b>TRAVERSE MOTOR TEST</b> From the Finishing Menu, select the following: Copies 5, Staple ON, Staple Dual <b>Does the Stapler Traverse Motor test ok?</b>	Go to step 4	Go to step 6
4	<b>STAPLER BASE INSPECTION</b> <b>Does the Stapler Base move freely back and forth?</b>	Go to step 7	Go to step 5

## 4025-Finisher

Step	Actions and Questions	Yes	No
5	<p><b>STAPLER ASSEMBLY</b>                      Replace the Stapler Assembly. Go to <b>“Stapler I Assembly Removal” on page 4-92</b>. From the Finishing Menu, select the following: Copies 5, Staple ON, Staple Dual  <b>Does the Stapler Base move freely back and forth?</b></p>	Problem solved	Go to step 9
6	<p><b>STAPLER TRAVERSE MOTOR</b>                      Replace the Stapler Traverse Motor. Go to <b>“Traverse Motor Assembly Removal” on page 4-102</b>. From the Finishing Menu, select the following: Copies 5, Staple ON, Staple Dual  <b>Does the Stapler Traverse Motor test ok?</b></p>	Problem solved	Go to step 7
7	<p><b>FINISHER MAIN BOARD</b>                      Replace the Finisher Main Board. Go to <b>“PWB Assembly-Main Removal” on page 4-132</b>. Check the Stapler function.  <b>Does the Stapler function correctly?</b></p>	Problem solved	Go to step 8
8	<p><b>MCU BOARD</b>                      Replace the MCU Board. Refer to the Printer Service Manual. Check the Stapler function.  <b>Does the Stapler function correctly?</b></p>	Problem solved	Go to step 9
9	<p>The following Finisher FRUs and areas are associated with this specific problem. One or more of these FRUs or areas may have failed partially or completely. If you cannot isolate this problem using these steps, replace each FRU or troubleshoot each area listed below, one at a time, until you isolate and solve the problem.</p> <ul style="list-style-type: none"> <li>• Wiring and connectors linking the FRUs.</li> <li>• Broken or damaged FRUs within the Stapler area, Compiler area, or along the paper path.</li> </ul>		

### 989 - Error Code Service Check

Logic control sensed that there is a problem with the Stapler Front Position Sensor.

Step	Actions and Questions	Yes	No
1	<p><b>SENSOR TEST</b>                      Enter Diagnostics and check the Stapler Front Sensor function. Insert then remove a sheet of paper into the sensor.  <b>Does the Operator Panel LCD change between OP and CL as you insert then remove the paper?</b></p>	Go to step 3	Go to step 2
2	<p><b>STAPLER FRONT SENSOR</b>                      Replace the Stapler Front Sensor. Insert then remove a sheet of paper into the sensor.  <b>Does the Operator Panel LCD change between OP and CL as you insert then remove the paper?</b></p>	Problem solved	Go to step 7

## 4025-Finisher

Step	Actions and Questions	Yes	No
3	<p><b>TRAVERSE MOTOR TEST</b> From the Finishing Menu, select the following: Copies 5, Staple ON, Staple Dual <b>Does the Stapler Traverse Motor test ok?</b></p>	Go to step 4	Go to step 6
4	<p><b>STAPLER BASE INSPECTION</b> From the Finishing Menu, select the following: Copies 5, Staple ON, Staple Dual <b>Does the Stapler Base move freely back and forth?</b></p>	Go to step 7	Go to step 5
5	<p><b>STAPLER ASSEMBLY</b> Replace the Stapler Assembly. Go to <b>“Stapler I Assembly Removal” on page 4-92</b>. From the Finishing Menu, select the following: Copies 5, Staple ON, Staple Dual <b>Does the Stapler Base move freely back and forth?</b></p>	Problem solved	Go to step 9
6	<p><b>STAPLER TRAVERSE MOTOR</b> Replace the Stapler Traverse Motor. Go to <b>“Traverse Motor Assembly Removal” on page 4-102</b>. From the Finishing Menu, select the following: Copies 5, Staple ON, Staple Dual <b>Does the Stapler Traverse Motor test ok?</b></p>	Problem solved	Go to step 7
7	<p><b>FINISHER MAIN BOARD</b> Replace the Finisher Main Board. Go to <b>“PWB Assembly-Main Removal” on page 4-132</b>. Check the Stapler function. <b>Does the Stapler function correctly?</b></p>	Problem solved	Go to step 8
8	<p><b>MCU BOARD</b> Replace the MCU Board. Refer to the Printer Service Manual. Check the Stapler function. <b>Does the Stapler function correctly?</b></p>	Problem solved	Go to step 9
9	<p>The following Finisher FRUs and areas are associated with this specific problem. One or more of these FRUs or areas may have failed partially or completely. If you cannot isolate this problem using these steps, replace each FRU or troubleshoot each area listed below, one at a time, until you isolate and solve the problem.</p> <ul style="list-style-type: none"> <li>• Wiring and connectors linking the FRUs.</li> <li>• Broken or damaged FRUs within the Stapler area, Compiler area, or along the paper path.</li> </ul>		

## 990 - Error Code Service Check

Logic control sensed that there is a problem with the Stapler Dual Position function.

Step	Actions and Questions	Yes	No
1	<b>SENSOR TEST</b> Enter Diagnostics and check the Stapler Front Sensor function. Insert then remove a sheet of paper into the sensor. <b>Does the Operator Panel LCD change between OP and CL as you insert then remove the paper?</b>	Go to step 3	Go to step 2
2	<b>STAPLER FRONT SENSOR</b> Replace the Stapler Front Sensor. Insert then remove a sheet of paper into the sensor. <b>Does the Operator Panel LCD change between OP and CL as you insert then remove the paper?</b>	Problem solved	Go to step 9
3	<b>SENSOR TEST</b> Enter Diagnostics and check the Stapler Head Home Sensor function. Insert then remove a sheet of paper into the sensor. <b>Does the Operator Panel LCD change between OP and CL as you insert then remove the paper?</b>	Go to step 5	Go to step 4
4	<b>STAPLER HEAD HOME SENSOR</b> Replace the Stapler Head Home Sensor. Go to <b>“Sensor, Stapler Home Position Traverse Removal” on page 4-113</b> . Insert then remove a sheet of paper into the sensor. <b>Does the Operator Panel LCD change between OP and CL as you insert then remove the paper?</b>	Problem solved	Go to step 9
5	<b>TRAVERSE MOTOR TEST</b> From the Finishing Menu, select the following: Copies 5, Staple ON, Staple Dual <b>Does the Stapler Traverse Motor test ok?</b>	Go to step 6	Go to step 8
6	<b>STAPLER BASE INSPECTION</b> From the Finishing Menu, select the following: Copies 5, Staple ON, Staple Dual <b>Does the Stapler Base move freely back and forth?</b>	Go to step 10	Go to step 7
7	<b>STAPLER ASSEMBLY</b> Replace the Stapler Assembly. Go to <b>“Stapler I Assembly Removal” on page 4-92</b> . From the Finishing Menu, select the following: Copies 5, Staple ON, Staple Dual <b>Does the Stapler Base move freely back and forth?</b>	Problem solved	Go to step 10
8	<b>STAPLER TRAVERSE MOTOR</b> Replace the Stapler Traverse Motor. Go to <b>“Traverse Motor Assembly Removal” on page 4-102</b> . From the Finishing Menu, select the following: Copies 5, Staple ON, Staple Dual <b>Does the Stapler Traverse Motor test ok?</b>	Problem solved	Go to step 9

## 4025-Finisher

Step	Actions and Questions	Yes	No
9	<b>FINISHER MAIN BOARD</b> Replace the Finisher Main Board. Go to <b>“PWB Assembly-Main Removal” on page 4-132.</b> <b>Check the Stapler function. Does the Stapler function correctly?</b>	Problem solved	Go to step 10
10	<b>MCU BOARD</b> Replace the MCU Board. Refer to the Printer Service Manual. <b>Check the Stapler function. Does the Stapler function correctly?</b>	Problem solved	

## 991 - Error Code Service Check

Logic control sensed that there is a problem with the Stapler Rear Position Sensor.

Step	Actions and Questions	Yes	No
1	<b>SENSOR TEST</b> Enter Diagnostics and check the Stapler Rear Sensor function. Insert then remove a sheet of paper into the sensor. <b>Does the Operator Panel LCD change between OP and CL as you insert then remove the paper?</b>	Go to step 3	Go to step 2
2	<b>STAPLER REAR SENSOR</b> Replace the Stapler Rear Sensor. Go to <b>“No Paper Sensor Assembly Removal” on page 4-136.</b> Insert then remove a sheet of paper into the sensor. <b>Does the Operator Panel LCD change between OP and CL as you insert then remove the paper?</b>	Problem solved	Go to step 7
3	<b>TRAVERSE MOTOR TEST</b> From the Finishing Menu, select the following: Copies 5, Staple ON, Staple Dual <b>Does the Stapler Traverse Motor test ok?</b>	Go to step 4	Go to step 6
4	<b>STAPLER BASE INSPECTION</b> From the Finishing Menu, select the following: Copies 5, Staple ON, Staple Dual <b>Does the Stapler Base move freely back and forth?</b>	Go to step 7	Go to step 5
5	<b>STAPLER ASSEMBLY</b> Replace the Stapler Assembly. Go to <b>“Stapler I Assembly Removal” on page 4-92.</b> From the Finishing Menu, select the following: Copies 5, Staple ON, Staple Dual <b>Does the Stapler Base move freely back and forth?</b>	Problem solved	Go to step 9

## 4025-Finisher

Step	Actions and Questions	Yes	No
6	<b>STAPLER TRAVERSE MOTOR</b> Replace the Stapler Traverse Motor. Go to <b>“Traverse Motor Assembly Removal” on page 4-102</b> . From the Finishing Menu, select the following: Copies 5, Staple ON, Staple Dual <b>Does the Stapler Traverse Motor test ok?</b>	Problem solved	Go to step 7
7	<b>FINISHER MAIN BOARD</b> Replace the Finisher Main Board. Go to <b>“PWB Assembly-Main Removal” on page 4-132</b> . Check the Stapler function. <b>Does the Stapler function correctly?</b>	Problem solved	Go to step 8
8	<b>MCU BOARD</b> Replace the MCU Board. Refer to the Printer Service Manual. Check the Stapler function. <b>Does the Stapler function correctly?</b>	Problem solved	Go to step 9
9	The following Finisher FRUs and areas are associated with this specific problem. One or more of these FRUs or areas may have failed partially or completely. If you cannot isolate this problem using these steps, replace each FRU or troubleshoot each area listed below, one at a time, until you isolate and solve the problem.  <ul style="list-style-type: none"> <li>• Wiring and connectors linking the FRUs.</li> <li>• Broken or damaged FRUs within the Stapler area, Compiler area, or along the paper path.</li> </ul>		

### 992 - Error Code Service Check

Logic control sensed that there is a problem with the Stapler Swing.

Step	Actions and Questions	Yes	No
1	<b>SWING MOTOR TEST</b> From the Finishing Menu, select the following: Copies 5, Staple ON, Staple Dual <b>Does the Stapler Swing Motor test ok?</b>	Go to step 2	Go to step 4
2	<b>STAPLER BASE INSPECTION</b> From the Finishing Menu, select the following: Copies 5, Staple ON, Staple Dual <b>Does the Stapler Base move freely back and forth?</b>	Go to step 5	Go to step 3
3	<b>STAPLER ASSEMBLY</b> Replace the Stapler Assembly. Go to <b>“Stapler I Assembly Removal” on page 4-92</b> . From the Finishing Menu, select the following: Copies 5, Staple ON, Staple Dual <b>Does the Stapler Base move freely back and forth?</b>	Problem solved	Go to step 7

## 4025-Finisher

Step	Actions and Questions	Yes	No
4	<b>SWING MOTOR</b> Replace the Swing Motor. Go to <b>“Motor Assembly-Swing Removal” on page 4-104</b> . From the Finishing Menu, select the following: Copies 5, Staple ON, Staple Dual <b>Does the Swing Motor test ok?</b>	Problem solved	Go to step 7
5	<b>FINISHER MAIN BOARD</b> Replace the Finisher Main Board. Go to <b>“PWB Assembly-Main Removal” on page 4-132</b> . Check the Stapler function. <b>Does the Stapler function correctly?</b>	Problem solved	Go to step 6
6	<b>MCU BOARD</b> Replace the MCU Board. Refer to the Printer Service Manual. Check the Stapler function. <b>Does the Stapler function correctly?</b>	Problem solved	Go to step 7
7	The following Finisher FRUs and areas are associated with this specific problem. One or more of these FRUs or areas may have failed partially or completely. If you cannot isolate this problem using these steps, replace each FRU or troubleshoot each area listed below, one at a time, until you isolate and solve the problem. <ul style="list-style-type: none"> <li>• Wiring and connectors linking the FRUs.</li> <li>• Broken or damaged FRUs within the Stapler area, Compiler area, or along the paper path.</li> </ul>		

## 995 - Error Code Service Check

Logic control sensed that the installed Finisher is not compatible with the printer.

Step	Actions and Questions	Yes	No
1	<b>FINISHER INSPECTION</b> Inspect the Finisher to make sure it is the correct manufacture and model for the printer. <b>Is the Finisher the correct manufacture and model for this printer?</b>	Go to step 2	Replace the Finisher with a correct one
2	<b>RESET</b> Switch off the printer and the Finisher. Wait one minute, then switch on the printer and the Finisher <b>Is the error code gone?</b>	Problem solved	Go to step 3
3	<b>RESEAT</b> Disconnect then reconnect the Finisher from the printer. <b>Is the error code gone?</b>	Problem solved	Go to step 4
4	<b>FINISHER MAIN BOARD</b> Replace the Finisher Main Board. Go to <b>“PWB Assembly-Main Removal” on page 4-132</b> . Check the Stapler function. <b>Does the Stapler function correctly?</b>	Problem solved	Go to step 5

## 4025-Finisher

Step	Actions and Questions	Yes	No
5	<p><b>MCU BOARD</b>                      Replace the MCU Board. Refer to the Printer Service Manual.                      Check the Stapler function.  <b>Does the Stapler function correctly?</b></p>	Problem solved	Go to step 6
6	<p>The following Finisher FRUs and areas are associated with this specific problem. One or more of these FRUs or areas may have failed partially or completely. If you cannot isolate this problem using these steps, replace each FRU or troubleshoot each area listed below, one at a time, until you isolate and solve the problem.</p> <ul style="list-style-type: none"> <li>• Wiring and connectors linking the FRUs.</li> </ul>		



---

## 3. Diagnostic Aids

### Entering Diagnostic Mode

Press and hold **Go** and **Return** as you turn on the printer to access Diagnostic Mode. While the Diagnostic Menu is active, all host interfaces are offline.

Diagnostics includes: Button Test, LCD test, Error Log, Printer Setup, Configuration ID, Device Test, base Sensor Test, and a demo or print test page.

### Exiting Diagnostic Mode

To exit diagnostic mode and POR the printer into normal user mode, select EXIT DIAGNOSTICS. Diagnostics are built into the printer MCU PWB (Engine Card) and can be accessed from the printer Operator Panel.

### Analyzing the Test Print

Test Prints provide several uses in troubleshooting the printer problems.

- Isolating problems to either the print engine (MCU PWB) or to the ESS PWB (Controller Card) and host software.
- Locating feed and paper transport problems.
- Detecting print quality and image registration problems.

### Using Test Print to Locate a Feed or Paper Transport Problem

Use Test Print to locate a problem with paper feed or with paper transportation along the paper path.

1. Enter Printer Diagnostics and generate a Test Print.
2. Follow the paper along the paper path until the problem occurs.

---

## Finisher Tests

### Staple Test

This test verifies the operation of the staple mechanism in the finisher.

The media used in this test is fed from the default paper source. After selecting a destination bin, the printer feeds eight pieces of media and accumulates all eight pieces of media in the finisher accumulator. After the last sheet is accumulated, the packet is stapled.

The staple test cannot be canceled or terminated when execution of the test has begun. As a result, no buttons are active during the execution of this test.

During execution of this test, the following message is displayed. The Power indicator blinks while pages are being fed through the printer and installed options.

```
Staple Test
Running...
```

When the test completes, the printer returns to the original screen.

### Finisher Sensor Test

This test determines whether or not the finisher sensors and switches are working correctly.

To run the test, Select the **Sensor Test** operation from the **FINISHER TESTS** top level menu. The following sensors are listed in the bottom level menu:

- FIN Input Path
- FIN Path Sensor
- FIN Exit Path
- Compiler Tray EX
- Roller Open HP
- Roller HP F
- Jogger HP F
- Jogger HP R
- Staple Traverse
- Stap Swing HP 1
- Stap Swing HP 2
- Comp Tray Paper
- Low Staple SW
- Staple Cartridge
- Staple CAM HP
- Staple Ready
- Stk Tray Paper
- Stk Hight Upper

## 4025-Finisher

- Stk Hight Lower
- Stk Tray Low Lmt
- Stack Tray Pos
- Dock Interlock
- Top Cover J
- Exit Roll
- Front Cover K
- Punch Dust Box M
- Close Door Message
- H-Tra Gate
- H-Tra Cover H
- H-Tra Input Path
- H-Tra Exit Path
- Punch Dust
- Top Tray Exit
- Top Tray Full
- Top Tray Empty

To select one of the sensors, press **Menu** until the sensor you want is displayed. Press **Select** for that sensor. The following is a sample screen that may be displayed:

```
FIN Input Path
CL
```

Once this screen is displayed, you can manually actuate the sensor. When the sensor is closed, **CL** is displayed. Likewise, when the sensor is open, **OP** is displayed. If the wrong message is displayed, then the sensor may be malfunctioning.

To exit the sensor test, press **Return**.

## 4025-Finisher

---

## 4. Removal and Replacement Procedures

This section contains the removal and replacement procedures for major parts within the printer Finisher. Before you begin any Removal and Replacement Procedure:

1. Switch OFF the printer power.
2. Disconnect the AC power cord from the electrical outlet.
3. Wear an electrostatic discharge wrist strap to protect sensitive printer parts from damage.

**Note:** Names of parts that appear in the Removals section may not be exactly the same as the names appear in the parts list. For example, an RRP for the MP feeder Tray Assembly may appear on the parts list as Tray Assembly MP feeder. Always reinstall the correct type and size screws. Using the wrong screw can damage tapped holes. Do not use excessive force to either remove or install a part.

---

### Notations in the text

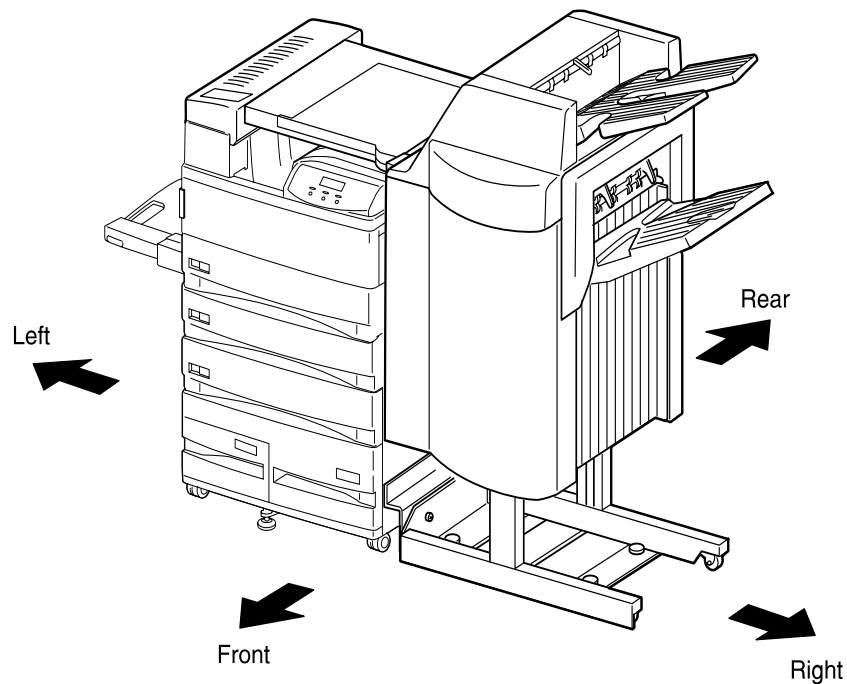

- Locations, such as R or right assume you are facing the printer console panel.
- The notation "(Figure X)" points to the illustration that corresponds to the repair you are performing.
- Arrows in an illustration show direction of movement when removing a component.

## Cover, Rear Removal

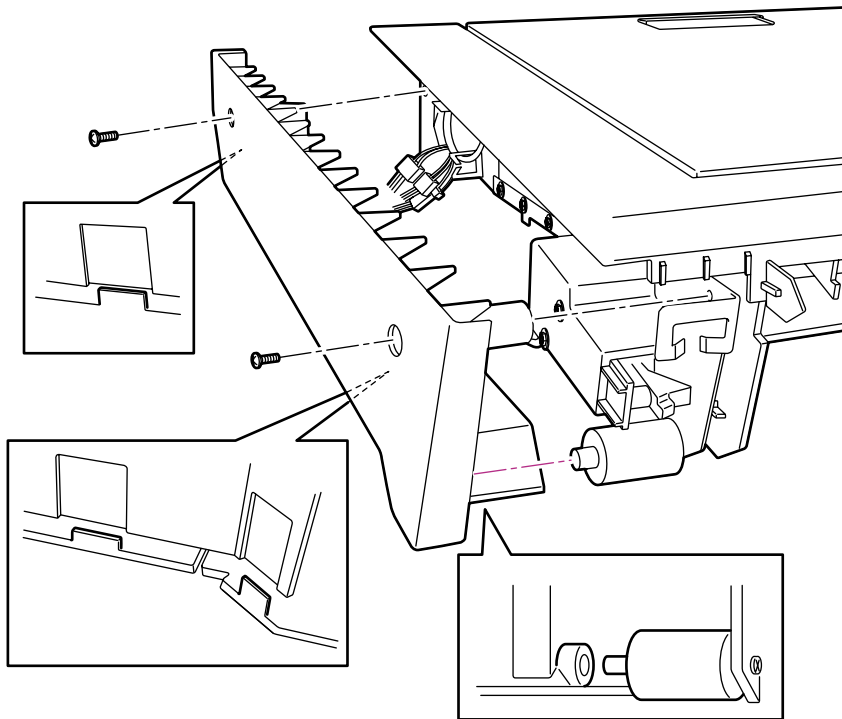

### Removal

- Remove two screws that secure the Rear Cover to the H-Tra, and then remove the cover.

### Replacement

1. Align the Rear Cover in the mounting position so that the shaft and three tabs of the H-Tra are met with the bearings and shape of the Rear Cover and that the harness passes through the notch.
2. Secure the Rear Cover with two screws.

## Spring Tension 80, Sensor and Harness Earth Removal

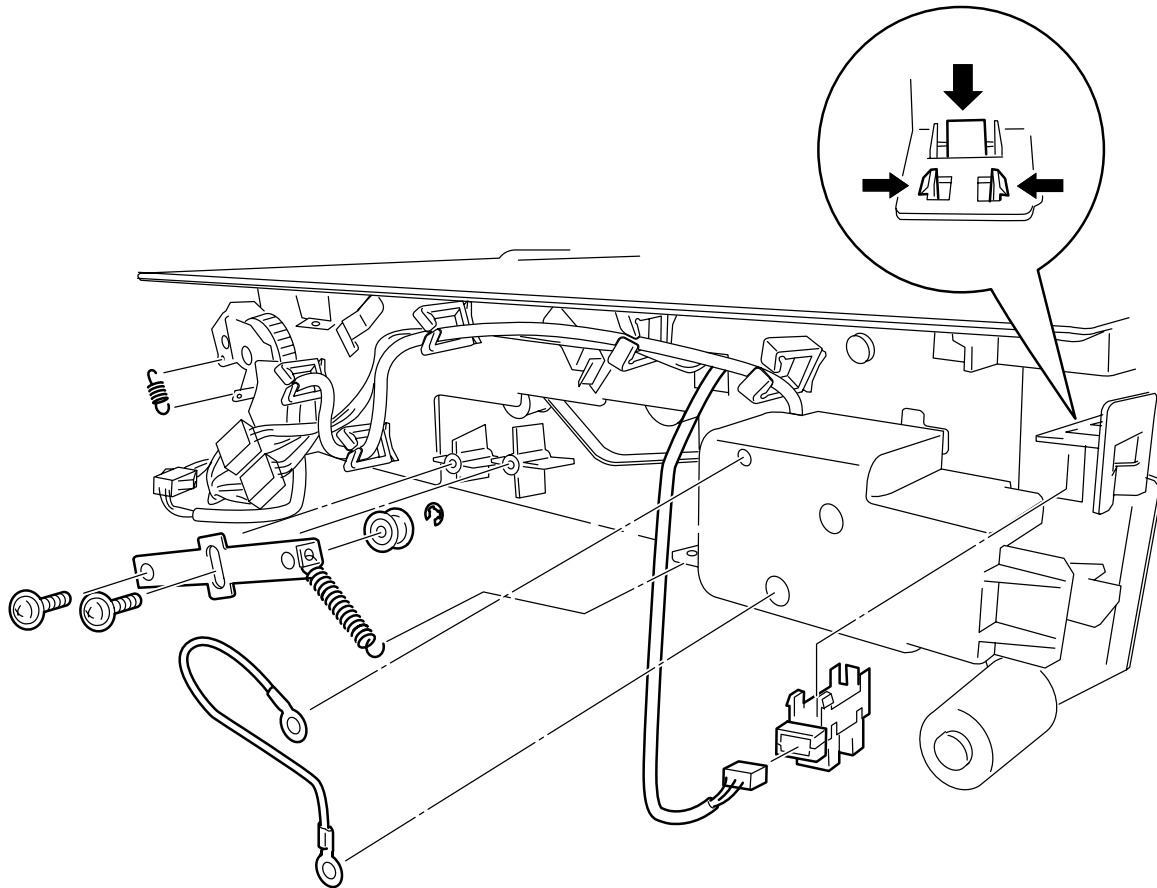

### Removal

1. Remove the Rear Cover.
2. Unhook the tension spring 80 from the hole in the H-Tra frame.
3. Remove two screws that secure the tension bracket assembly to the H-Tra, and remove the tension bracket assembly together with tension spring 80.
4. Unhook the tension spring 80 from the hole in the tension bracket assembly, and remove the tension spring Tension 80.
5. Unplug the connector (P/J 260) of the H-Tra harness assembly from the sensor.
6. Unhook the sensor at three places, and remove the sensor.
7. Remove two screws that secure the earth harness to the H-Tra, and remove the earth harness.

## Replacement

1. Secure the harness earth to the H-Tra with two screws.
2. Align the sensor with the mounting position in the H-Tra, and push it in with your fingers to secure.
3. Plug the connector (P/J 260) of the H-Tra harness assembly to the sensor.
4. Align the tension bracket assembly with the mounting position in the H-Tra, and secure it with two screws.
5. Hook the tension spring 80 to the holes in the tension bracket assembly and the H-Tra frame.
6. Mount the Rear Cover.



## Belt-Sync Removal

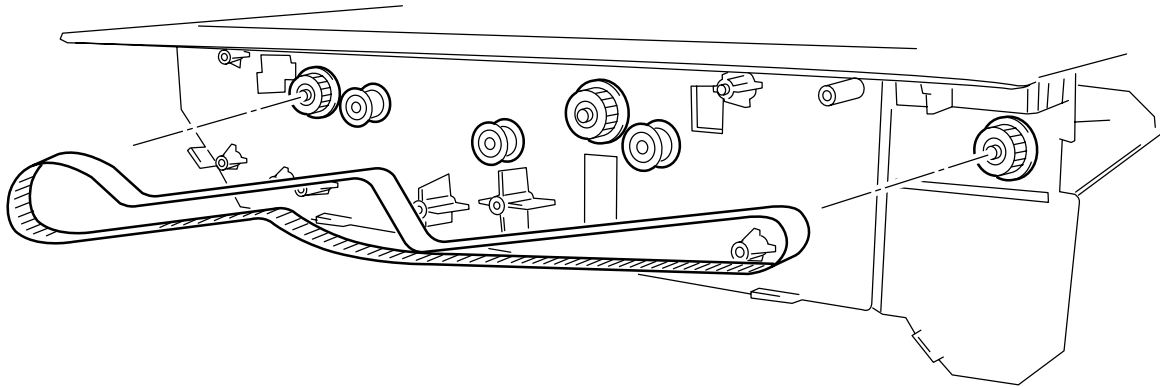

### Removal

1. Remove the Rear Cover.
2. Unplug the connector (P/J 260) of the H-Tra harness assembly from the sensor.
3. Remove the Pulley 2, tension spring 80, sensor and earth harness.
4. Remove the Solenoid Assembly-gate in.
5. Remove the Transport Gear Kit.
6. Remove the Bracket Assembly.
7. Remove the Belt-sync from the H-Tra.

### Replacement

1. Mount the Belt-sync while taking care of the routing to the gear and pulley on the H-Tra.
2. Mount the Bracket Assembly.
3. Mount the Transport Gear Kit.
4. Mount the solenoid assembly-gate in.
5. Mount the pulley 2, tension spring 80, sensor and earth harness.
6. Plug the connector (P/J 260) of the H-Tra harness assembly to the sensor.
7. Mount the Rear Cover.

## Bracket Assembly Removal

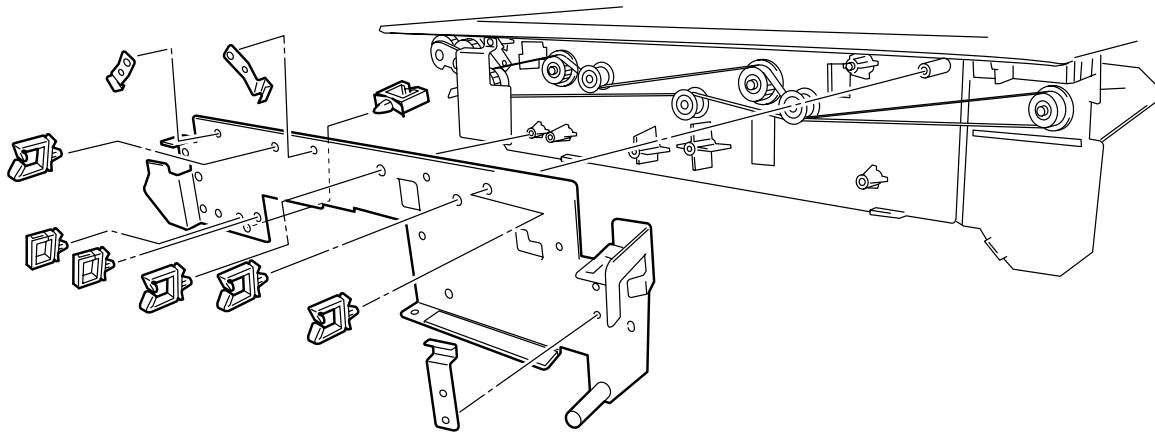

### Removal

1. Remove the Rear Cover.
2. Unplug the connector (P/J 260) of the H-Tra harness assembly from the sensor.
3. Remove the Pulley 2, tension spring 80, sensor and earth harness.
4. Remove the Solenoid Assembly-gate in.
5. Remove the Transport Gear Kit.
6. Remove three screws that secure the bracket assembly together with three spring plate to the H-Tra, and remove three spring plate.
7. Remove the screw that secures the bracket assembly, and remove the bracket assembly together with the saddle clamp.
8. From the back of the bracket assembly, tighten each latch of the five saddle clamp with pliers to remove them.

### Replacement

1. Push the five Saddle Clamps into five holes in the Bracket Assembly to mount them.
2. Align the Bracket Assembly with the mounting position in the H-Tra, and secure it with a screw.
3. Align the Three Spring Plate with the mounting positions on the Bracket Assembly, and secure them with a screw respectively.
4. Mount the Transport Gear Kit.
5. Mount the Solenoid Assembly-gate in.
6. Mount the Pulley 2, Spring Tension 80, and the Sensor And Harness Earth.
7. Plug the connector (P/J 260) of the H-Tra Harness Assembly to the sensor.
8. Mount the Rear Cover.

## Tray Harness Assembly Removal

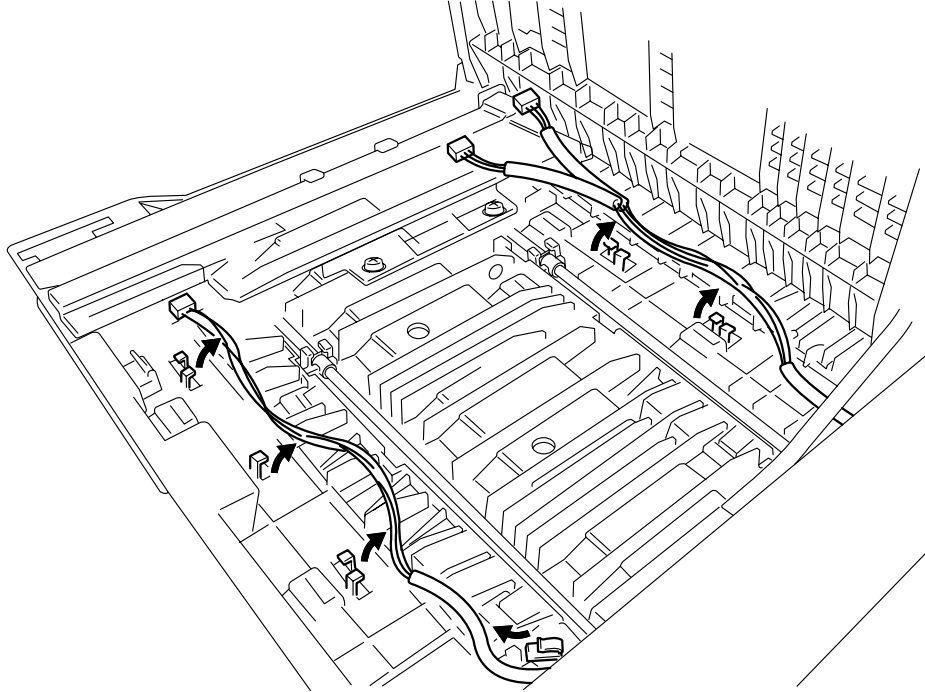

### Removal

1. Remove the Rear Cover.
2. Open the Top Cover of the H-Tra.
3. Remove the Sensor.
4. Unclamp the H-Tra harness assembly at seven places on the H-Tra.
5. Unclamp the H-Tra harness assembly at four places on the H-Tra.
6. Unplug the connector (P/J 256M) of the solenoid assembly.
7. Unplug three connectors (P/J 882A,879A,880A) of the harness connection, and remove the harness connection.
8. Unplug the connector (P/J 260) of the H-Tra harness assembly from the sensor.
9. From the lower side, tighten the latch of clamp on the bracket assembly with radio pliers to release the H-Tra harness assembly together with the clamp.
10. Pull the connector (P/J 263) and the harness of the spring tension 80 off the hole on the rear of the H-Tra.
11. Pull the connectors (P/J 275M,259) and the harnesses of the spring tension 80 and sensor full off the hole on the rear of the H-Tra.
12. Unclamp the H-Tra harness assembly at four places on the bracket assembly, and remove the tray harness assembly.

## Replacement

1. Insert the connectors (P/J 275M,259) and the harnesses of the spring tension 80 and sensor full from the hole on the rear of the H-Tra, and clamp them at four places on the top surface of the H-Tra.
2. Insert the connector (P/J 263) and the harness of the spring tension 80 from the hole on the rear of the H-Tra, and clamp them at seven places on the top surface of the H-Tra.
3. Clamp the H-Tra harness assembly at four places on the bracket assembly.
4. Clamp the H-Tra harness assembly at one place, and push the latch of that clamp into the hole on the Bracket Assembly with your fingers to mount it. (Figure 2)
5. Plug the connector (P/J 260) of the Sensor.
6. Plug three connectors (P/J 882A,879A,880A) of the Harness Connection, and mount the Harness Connection on the H-Tra harness assembly.
7. Plug the connector (P/J 256M) of the Solenoid Assembly.
8. Mount the Sensor and Sensor.
9. Mount the Sensor.
10. Close the top cover of the H-Tra.
11. Mount the Rear Cover.

## Transport Gear Kit Removal

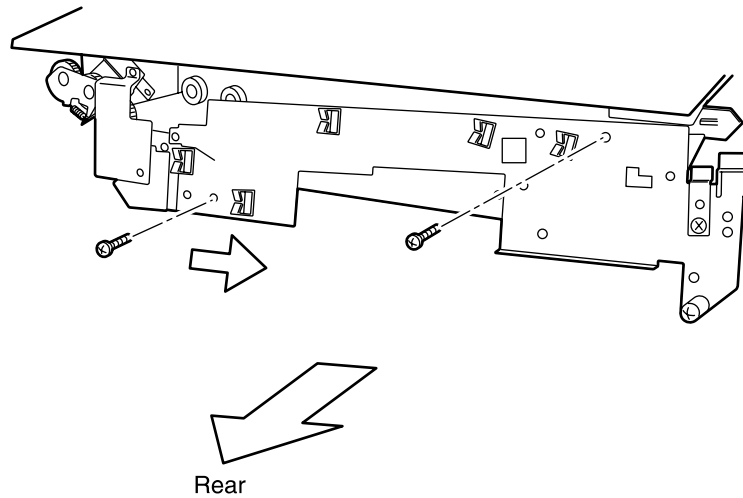

### Removal

1. Remove the Rear Cover.
2. Remove the Pulley 2, Spring Tension 80, Sensor and Harness Earth.
3. Remove the Solenoid Assembly-Gate.
4. Remove two screws that secure the Bracket Assembly to the H-Tra, and shift the Bracket Assembly in the arrow direction.
5. Remove two screws that secure the Idler Bracket, and remove the Idler Bracket.
6. Unhook the Spring Gear 250 from the hole in the Support Assembly Gear Idler HT.
7. Unhook the Spring Gear 250 from the hole in the Bracket Assembly, and remove the Spring Gear 250.
8. Remove the E-ring that secures the Gear Idler, Support Assembly Gear Idler HT and Gear Idler L to the shaft of the Bracket Assembly Drive, and then remove the Gear Idler, Support Assembly Gear Idler HT and Gear Idler L.
9. Remove the E-ring that secures the Gear Idler to the shaft of the Support Assembly Gear Idler HT, and remove the Gear Idler.
10. Remove the E-ring that secures the Gear Pulley 32/26 to the shaft of the Bracket Assembly Drive, and remove the Gear Pulley 32/26.
11. Remove two screws that secure the Bracket Assembly Drive to the H-Tra, and remove the Bracket Assembly Drive.

### Replacement

1. Align the Bracket Assembly Drive with the mounting position in the H-Tra, and secure it with two screws.
2. Place the Belt-sync through the shaft of the Bracket Assembly Drive.
3. Insert the Gear Pulley 32/26 into the shaft of the Bracket Assembly Drive, and engage the Belt-sync a little with the Gear Pulley 32/26 and push it in position.
4. Secure the Gear Pulley 32/26 with an E-ring.
5. Insert the Gear Idler into the shaft of the Support Assembly Gear Idler HT, and secure it with an E-ring.
6. Insert the Gear Idler L into the shaft of the Bracket Assembly Drive.
7. Insert the shaft of the Bracket Assembly Drive into the hole in the Support Assembly Gear Idler HT so that the convex (stopper) of the Support Assembly Gear Idler HT is above the sheet metal of the Bracket Assembly Drive, and secure it with an E-ring.
8. Hook the Spring Gear 250 on both sides to holes in the Bracket Assembly and Support Assembly Gear Idler HT.
9. Align the Idler Bracket with the mounting position, and secure it with two screws.
10. Align the Bracket Assembly with the mounting position, and secure it with two screws.
11. Mount the Solenoid Assembly-Gate In.
12. Mount the Pulley 2, Spring Tension 80, Sensor and Harness Earth.
13. Mount the Rear Cover.

## Solenoid Assembly-Gate In Removal

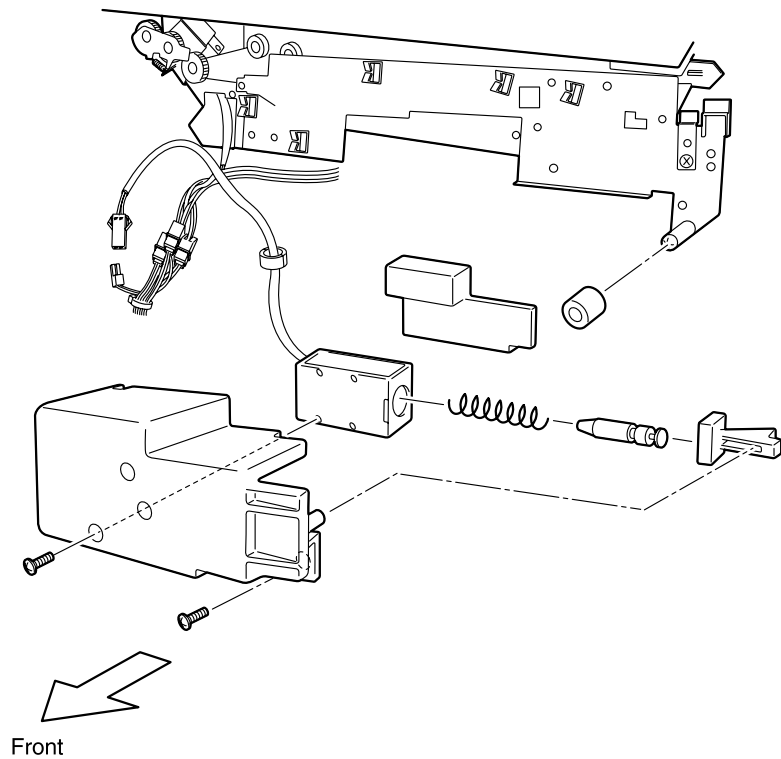

### Removal

1. Remove the Rear Cover.
2. Unplug the connector (P/J 256M) of the Solenoid Assembly.
3. Unclamp the harness of the Solenoid Assembly at five places on the Bracket Assembly.
4. Pull the Roller off the shaft of the Bracket Assembly.
5. Remove two screws that secure the Cover Assembly Solenoid, and remove the Cover Assembly Solenoid together with the Solenoid Assembly-Gate In.
6. Pull the Bracket Assembly Damper off the Cover Assembly Solenoid with your fingers.
7. Remove the screw that secures Solenoid Assembly to the Cover Assembly Solenoid, and remove the Solenoid Assembly-Gate In.
8. Pull off the Link Assembly Damper together with the plunger of the Solenoid Assembly.
9. Sliding the Link Assembly Damper, remove it from the plunger of the Solenoid Assembly.

## Replacement

1. Sliding the Link Assembly Damper so that the convex of the Solenoid Assembly is engaged with the concave of the plunger of the Solenoid Assembly, mount the Link Assembly Damper.
2. Insert the Spring Solenoid into the plunger of the Solenoid Assembly, and push the Link Assembly Damper together with the Spring Solenoid and the plunger of the Solenoid Assembly into the hole in the solenoid.
3. Align the Solenoid Assembly together with the Link Assembly Damper and Spring Solenoid with the mounting position in the Cover Assembly Solenoid, and secure them with a screw.
4. Push the Bracket Assembly Damper into the Cover Assembly Solenoid with your fingers.
5. Secure the Cover Assembly Solenoid together with the Solenoid Assembly-Gate In to the H-Tra with two screws.
6. Insert the Roller into the shaft of the Bracket Assembly so that the convex of the Roller face is toward the frame.
7. Clamp the harness of the Solenoid Assembly at five places on the Bracket Assembly.
8. Plug the connector (P/J 256M) of the Solenoid Assembly.
9. Mount the Rear Cover.



## Cover Top H-Tra Assembly Removal

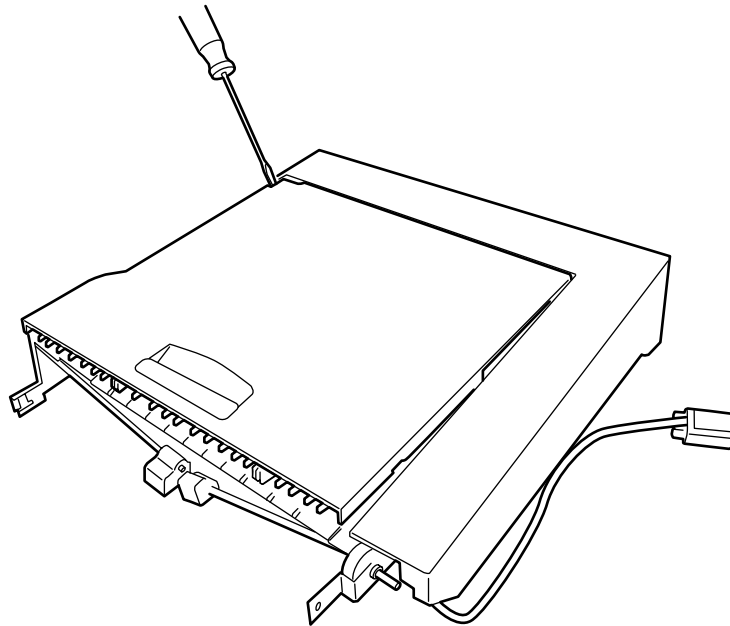

### Removal

1. Insert a flat-tip screwdriver between the cover on the front of the H-Tra and the Cover Assembly Open, and deflect the cover on the front of the H-Tra to release the bearing on the front of the Cover Assembly Open from the shaft on the front of the H-Tra.
2. Remove the Cover Top H-Tra Assembly in the front diagonal upward direction.

### Replacement

1. Insert the shaft on the rear of the Cover Top H-Tra Assembly into the hole on the rear of the H-Tra.
2. Deflecting the cover on the front of the H-Tra, and insert the shaft on the front of the H-Tra into the hole on the front of the Cover Top H-Tra Assembly.

## Roll Transport and Aligner Roll Kit Removal

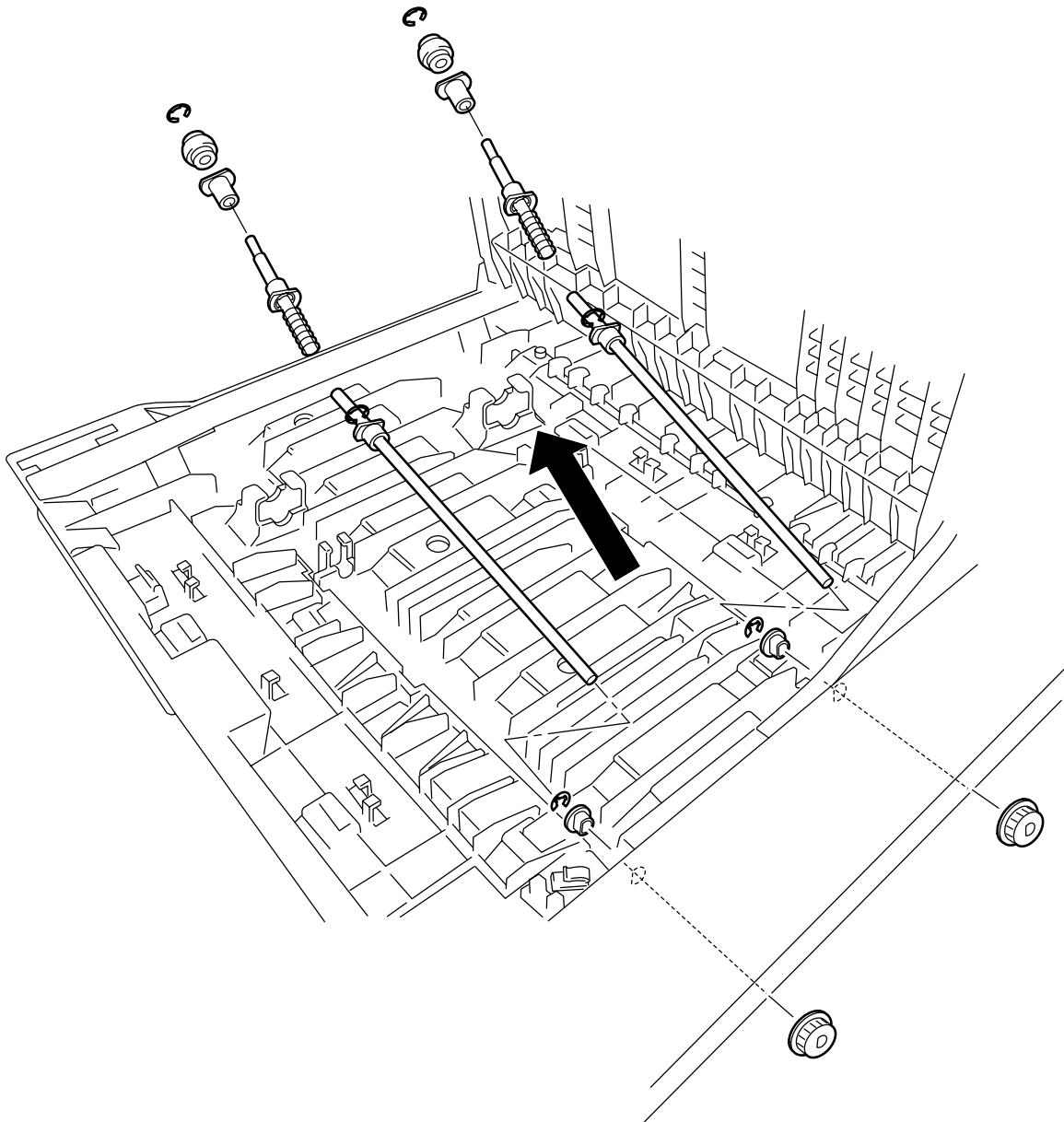

## 4025-Finisher

### Removal

1. Remove the Rear Cover.
2. Unplug the connector (P/J 260) of the H-Tra harness assembly from the Sensor.
3. Remove the Pulley 2, Spring Tension 80, Sensor and Harness Earth.
4. Remove the Solenoid Assembly-Gate In.
5. Remove the Transport Gear Kit.
6. Remove the Bracket Assembly.
7. Remove the Belt-Sync.
8. Open the top cover of the H-Tra.

**Note:** In the following steps, the procedure for removing the Roll Transport and Aligner Roll Kit on the right side is the same as for removing the ones on the left side, and therefore the procedure on the right side only is described. Apply the same procedure to the left side.

9. Remove the Pulley Oneway from the Roll Transport.
10. Remove five screws that secure to the H-Tra from the Guide Assembly-Aligner, and remove the Guide Assembly-Aligner.
11. Remove the E-ring that secures the Aligner Roll and remove the Aligner Roll.
12. Remove the E-ring that secures the Bearing.
13. Shift the Shaft Aligner Roll toward the front, and pull it off the Roll Transport.
14. Remove the E-ring that secures the Bearing, and remove the Roll Transport together with them.

### Replacement

**Note:** In the following steps, the procedure for removing the Roll Transport and Aligner Roll Kit on the right side is the same as for removing the ones on the left side, and therefore the procedure on the right side only is described. Apply the same procedure to the left side.

1. Insert the Bearing into the hole in the H-Tra.
2. Aligning the Roll Transport with the mounting positions in the H-Tra, insert the Bearing into the Roll Transport, and secure two bearings with an E-ring.
3. With two Bearing inserted into the Shaft Aligner Roll, align it with the mounting position in the H-Tra, and secure it with an E-ring.
4. Insert the Aligner Roll into the Shaft Aligner Roll, and secure it with an E-ring.
5. Aligning the Guide Assembly-Aligner with the mounting position in the H-Tra, and secure it with five screws.
6. Insert the Pulley Oneway into the Roll Transport.
7. Mount the Belt-Sync.
8. Mount the Bracket Assembly.
9. Mount the Transport Gear Kit.
10. Mount the Solenoid Assembly-Gate In.
11. Mount the Pulley 2, Spring Tension 80, Sensor and Harness Earth.
12. Plug the connector (P/J 260) of the H-Tra harness assembly to the Sensor.
13. Mount the Rear Cover.

### Entrance Roll Removal

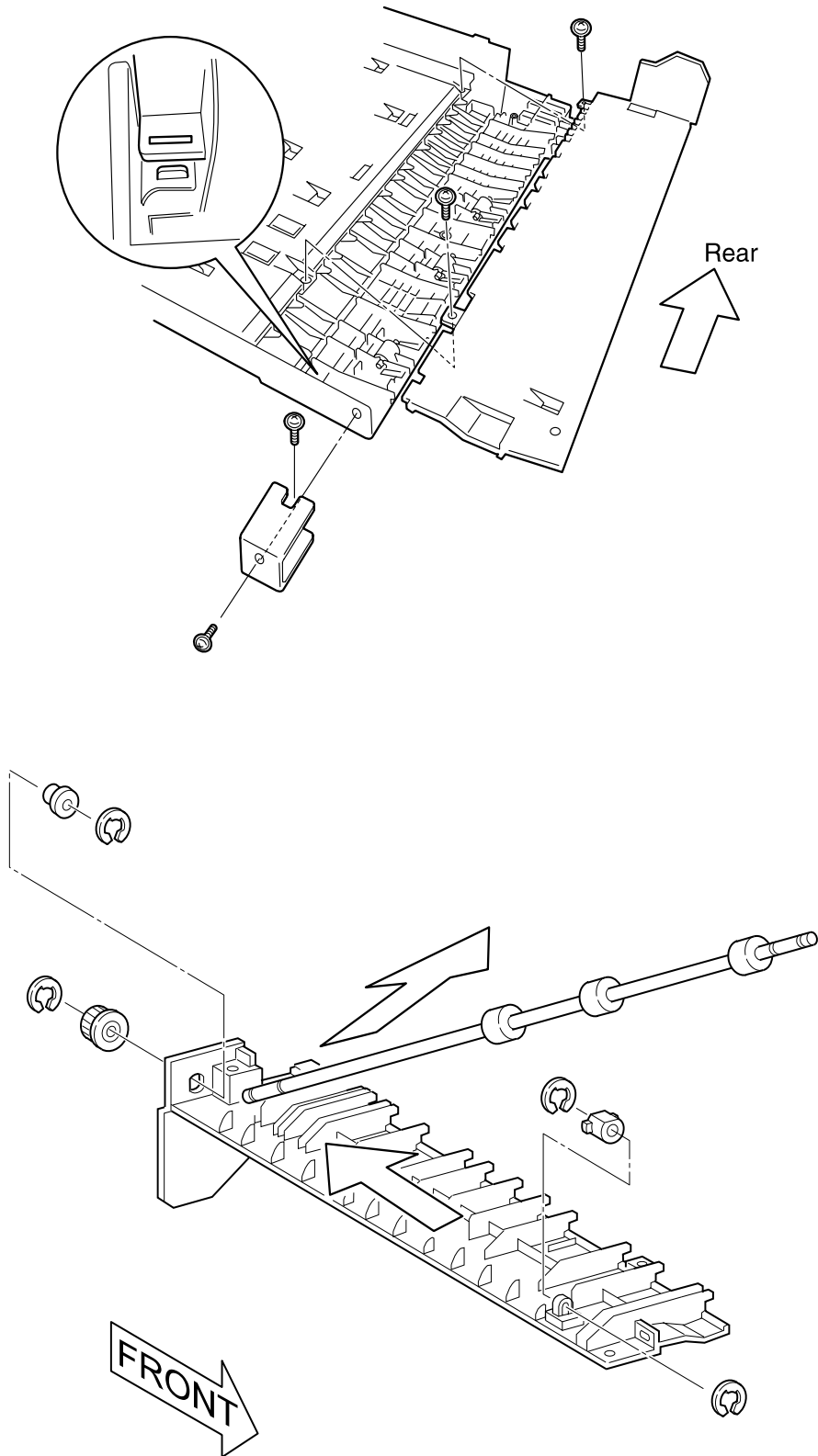

### Removal

1. Remove the Rear Cover.
2. Unplug the connector (P/J 260) of the H-Tra harness assembly from the Sensor.
3. Remove the Pulley 2, Spring Tension 80, Sensor and Harness Earth.
4. Remove the Solenoid Assembly-Gate In.
5. Remove the Transport Gear Kit.
6. Remove the Bracket Assembly.
7. Remove the Belt-Sync.
8. Invert the H-Tra, remove two screws that secure to the H-Tra from the Bracket, and remove the Bracket.
9. Remove two screws that secure to the H-Tra from the Cover Chute and remove the Cover Chute, together with the Pulley Oneway, Bearing Entrance Roll from the H-Tra.
10. Remove the E-ring that secures the Pulley Oneway to the shaft of the Entrance Roll, and remove the Pulley Oneway.
11. Remove E-rings on both sides of the Entrance Roll, slide the Entrance Roll toward the rear, and pull the shaft of the Entrance Roll off the hole in the Bearing.
12. Pull the Entrance Roll together with the Bearing in a diagonal upward direction.
13. Remove the Bearing from the shaft of the Entrance Roll.

### Replacement

1. Insert the Bearing into the shaft on the front side of the Entrance Roll, and Insert Bearing into the shaft on the rear side.
2. Insert the shaft on the rear side of the Entrance Roll into the hole on the rear side, and insert the shaft on the front side of the Entrance Roll into the hole on the Pulley Oneway.
3. Align both sides of the Entrance Roll with the mounting positions using the Bearing and secure it with two E-rings.
4. Insert the Pulley Oneway into the shaft on the rear side of the Roll Transport, and secure it with an E-ring.
5. Align the Cover Chute together with the Pulley Oneway, Bearing, Entrance Roll, with the mounting position in the H-Tra, and secure them with two screws.
6. Align the Bracket, with the mounting position in the H-Tra, and secure it with a screw.
7. Mount the Belt-Sync.
8. Mount the Bracket Assembly.
9. Mount the Transport Gear Kit.
10. Mount the Solenoid Assembly-Gate In.
11. Mount the Pulley 2, Spring Tension 80, Sensor and Harness Earth.
12. Plug the connector (P/J 260) of the H-Tra harness assembly to the Sensor.
13. Mount the Rear Cover.

## Sensor and Sensor Full Removal

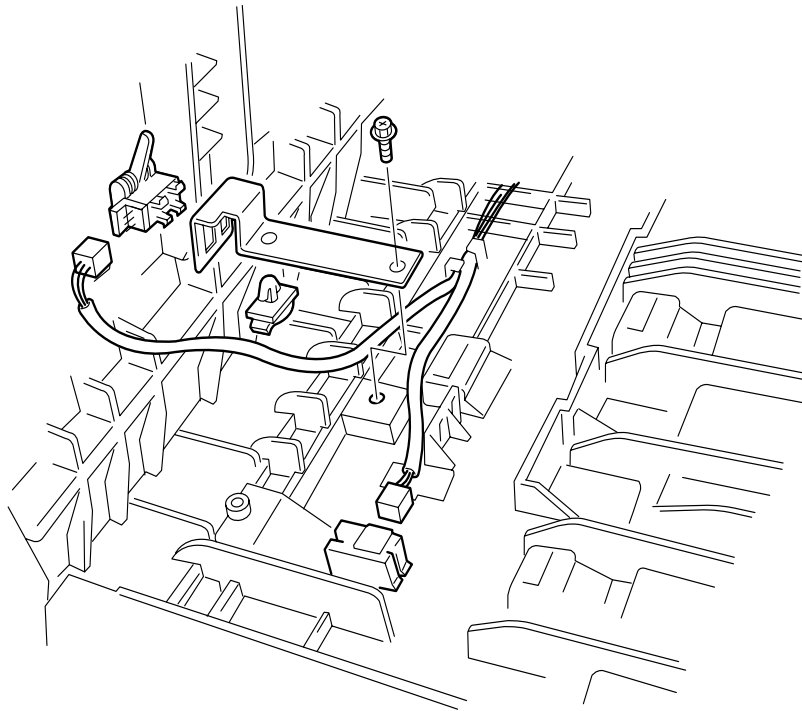
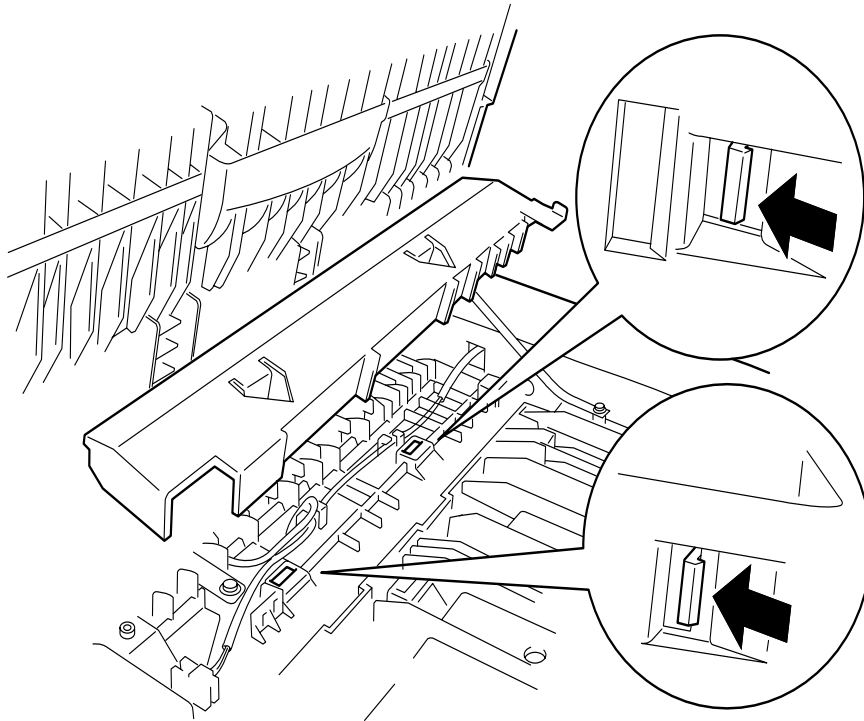

### Removal

1. Open the top cover of the H-Tra, and unhook the Cover Sensor Full at two places from the back of the H-Tra, and remove the Cover Sensor Full. (Figure 1)
2. Remove the screw that secures the Bracket Path Sensor to the H-Tra, and remove the Bracket Path Sensor together with the Spring Tension 80 and Clamp MINI.
3. Release the Roll Pinch from the Idler Bracket.
4. Unplug the connector (P/J 259) of the H-Tra harness assembly from the Sensor Full.
5. Tighten the latch of the Clamp MINI with radio pliers, and remove the Clamp MINI from the Bracket Path Sensor.
6. Unhook the Spring Tension 80 at three places, and remove the Spring Tension 80 from the Bracket Path Sensor.
7. Unplug the connector (P/J 275M) of the H-Tra harness assembly from the Spring Tension 80.
8. Unhook the Sensor at four places, and remove the Sensor from the bottom of the H-Tra.

### Replacement

1. Insert the Sensor Full from the bottom of the H-Tra so that its connector faces toward the rear.
2. Plug the connector (P/J 275M) of the H-Tra harness assembly to the Spring Tension 80.
3. Insert the latch of the Clamp MINI into the hole in the Bracket Path Sensor, and secure the Clamp MINI.
4. Align the Spring Tension 80 with the mounting position in the Bracket Path Sensor, and mount the Spring Tension 80.
5. Plug the connector (P/J 259) of the H-Tra harness assembly to the Sensor.
6. Clamp the H-Tra harness assembly with the Spring Tension 80.
7. Align the Bracket Path Sensor, together with the Spring Tension 80 and Clamp MINI, with the mounting positions in the H-Tra, and secure them with a screw.
8. Align the Cover Sensor Full with the mounting position in the H-Tra, and secure the Cover Sensor Full. (Figure 1)
9. Close the top cover of the H-Tra.

## Sensors Removal

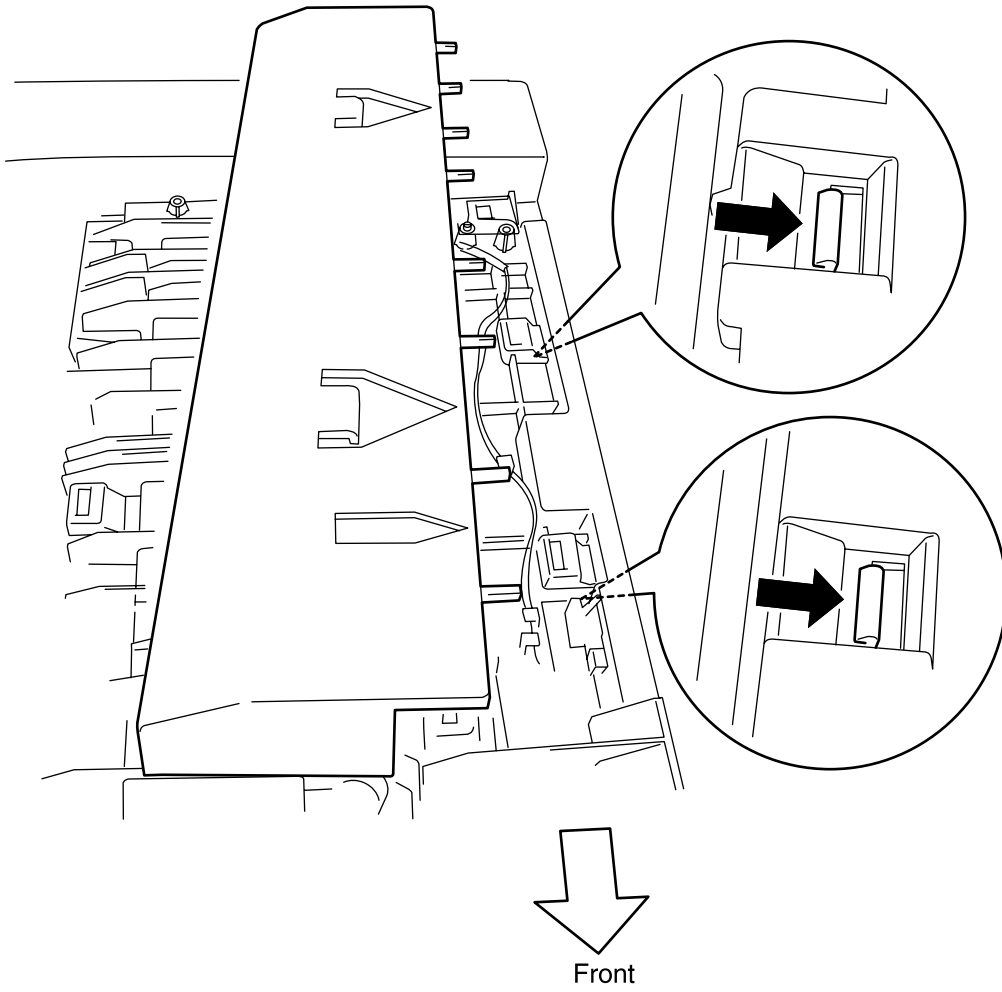



### Removal

1. Open the top cover of the H-Tra, and unhook the Cover Sensor Path at two places from the back of the H-Tra, and remove the Cover Sensor Path.
2. Remove the Rear Cover.
3. Unplug the connector (P/J 261) of the H-Tra harness assembly from the Sensor.
4. Remove the screw that secures to the H-Tra from the Plate Sensor Photo, and lift up the Plate Sensor Photo together with the Sensor and Clamp MINI.
5. Unhook the Sensor at three places from the rear side of the Plate Sensor Photo, and remove the Sensor.
6. Unplug the connector (P/J 263) of the H-Tra harness assembly from the Spring Tension 80.
7. Unhook the Spring Tension 80 at four places from the right side of the H-Tra, and remove the Spring Tension 80.

### Replacement

1. Align the Spring Tension 80 with the mounting position in the H-Tra, and secure it.
2. Plug the connector (P/J 263) of the H-Tra harness assembly to the Spring Tension 80.
3. Align the Sensor with the mounting position in the Plate Sensor Photo, and secure it.
4. Align the Plate Sensor Photo, with the mounting positions in the H-Tra, and secure them with a screw.
5. Plug the connector (P/J 261) of the H-Tra harness assembly to the Sensor.
6. Mount the Rear Cover.
7. Align the Cover Sensor Path with the mounting position in the H-Tra, and secure it.
8. Close the top cover of the H-Tra.

## Shaft Transport Removal

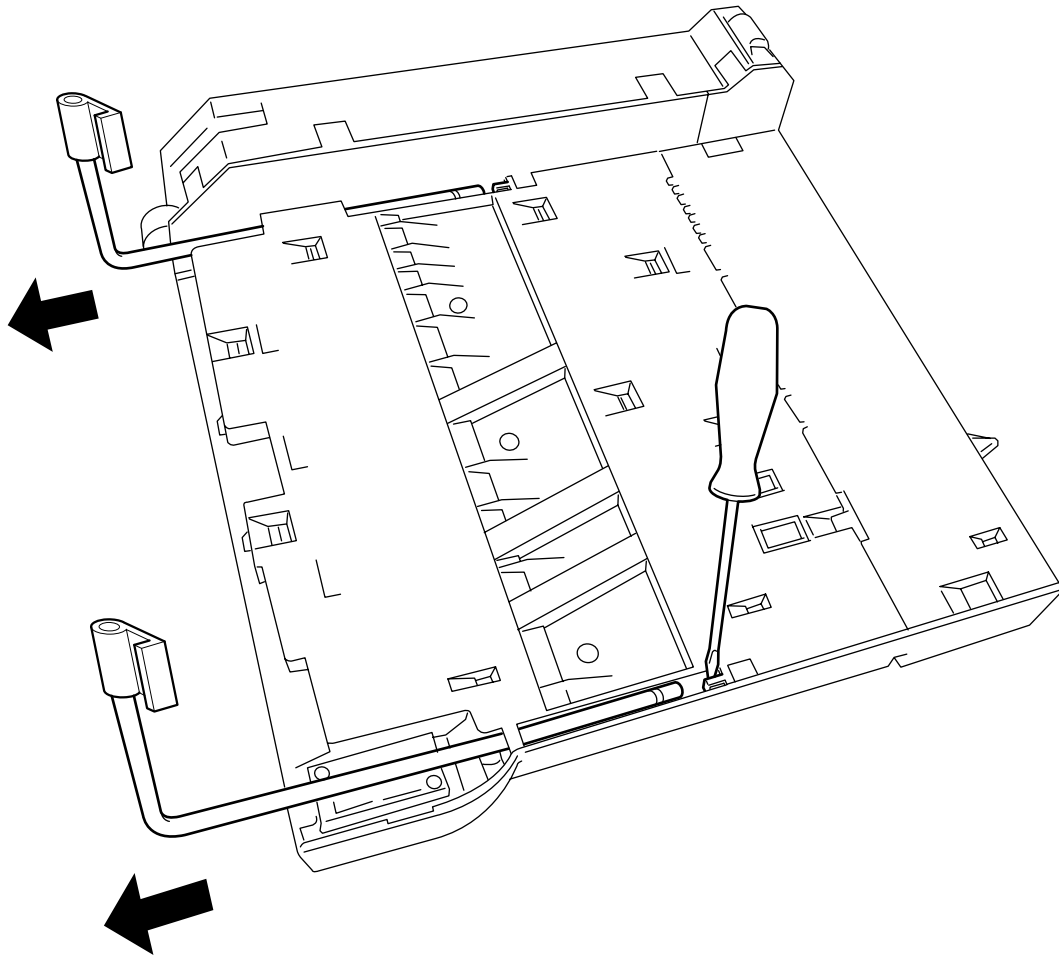

### Removal

1. Invert the H-Tra, and insert a flat-tip screwdriver into the hook of the Frame Assembly that secures the Shaft Transport on the front side, and pull off the Shaft Transport on the front side toward the right.
2. For the Shaft Transport on the rear side, perform the above step in the same manner.

### Replacement

1. Insert the Shaft Transport on the front side into the H-Tra.
2. For the Shaft Transport on the rear side, perform the above step in the same manner.

## Cover-Jogging Removal

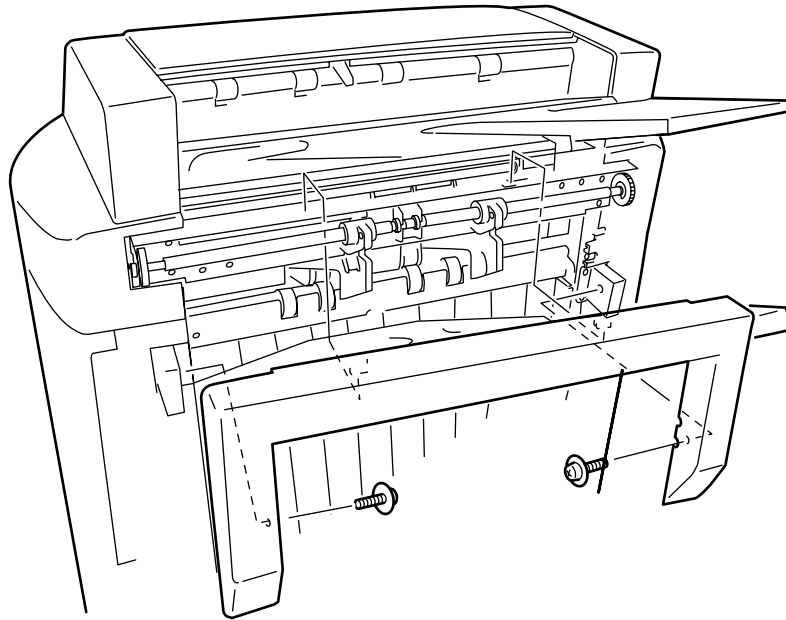

### Removal

- Remove two screws that secure the Cover-Jogging to the Finisher, and remove the Cover-Jogging.

### Replacement

- Align the Cover-Jogging with the mounting position, and secure it with two screws.

## Tray-Lower Removal

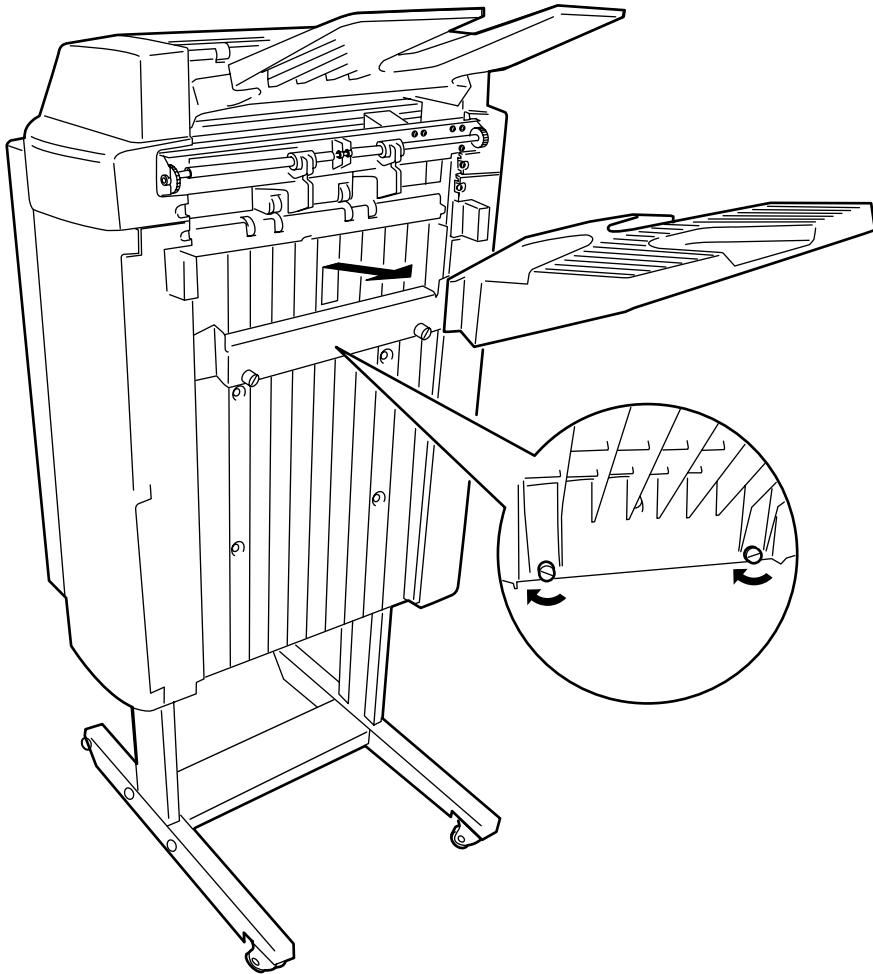

### Removal

1. Loosen two screws on the Cover-Top F that secure the Tray-Lower and are located under the Bracket Tray Lower.
2. Lift up and remove the Tray-Lower.

### Replacement

1. From the top, insert two notches of the Tray-Lower into a space between the sheet metal of the Bracket Tray Lower and two screws.
2. Tighten two screws on the Bracket, and secure the Tray-Lower.

## Cover-Top, Front and Rear Removal

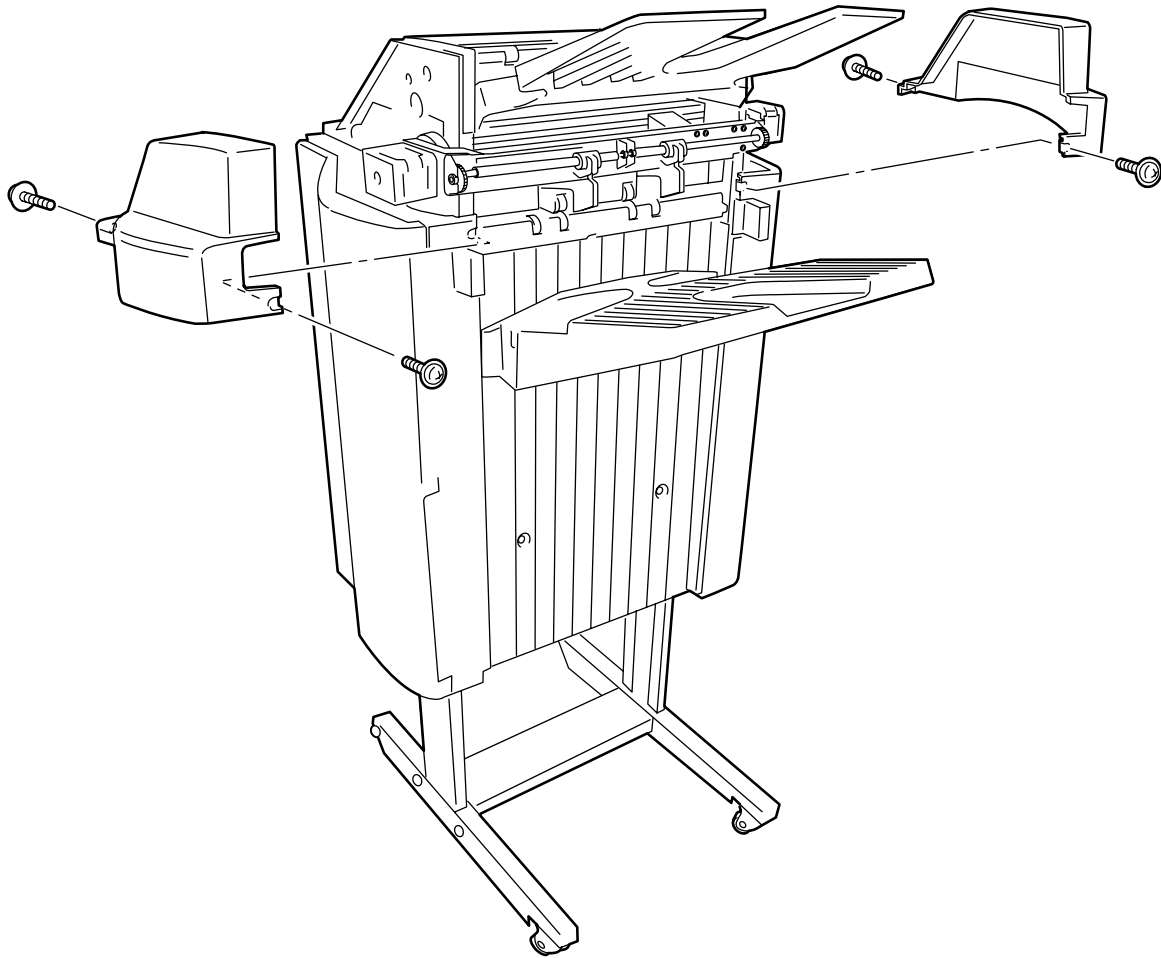

### Removal

1. Remove the Cover-Jogging.
2. Remove two screws that secure the Cover-Top, Front, and remove the Cover-Top, Front.
3. Remove two screws that secure the Cover-Top, Rear, and remove the Cover-Top, Rear.

### Replacement

1. Align the Cover-Top, Rear with the mounting position, and secure it with two screws.
2. Align the Cover-Top, Front with the mounting position, and secure it with two screws.
3. Mount the Cover-Jogging.

## Cover-Open, Cover-Front and Kit Stud Cover Removal

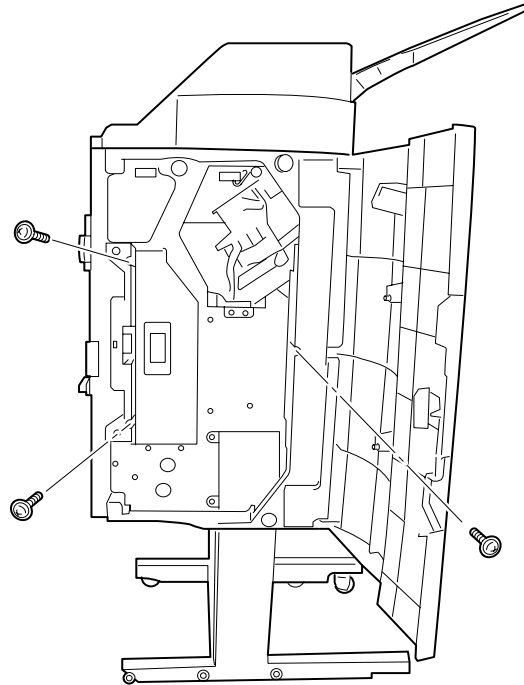

### Removal

1. Remove the Cover-Jogging.
2. Open the Cover-Open, Front, and remove three screws that secure the Cover-Front to the Finisher.
3. Remove four screws that secure the Cover-Front, and remove the Cover-Front together with the Stud Cover and Cover-Open, Front.
4. From the back of the Cover-Front, face the notch of the upper Stud Cover toward the back.
5. Pushing the latch of the upper Stud Cover, pull it off upward from the Cover-Open, Front and Cover-Front.
6. From the back of the Cover-Front, face the notch of the lower Stud Cover toward the back.
7. Pushing the latch of the lower Stud Cover, pull it off upward from the Cover-Open, Front and Cover-Front.
8. Push the bearing of the Cover-Open, Front out of the square hole in the center of the Cover-Front by lever action using a flat-tip screwdriver inserted between the bearing of the Cover-Open, Front and the shaft of the Cover-Front.

## Replacement

1. Aligning the shaft in the center of the Cover-Front with the bearing in the center of the Cover-Open, Front, push them in to mount the Cover-Open, Front on the Cover-Front.
2. Insert the Stud Cover into the hole at the bottom surface of the Cover-Open, Front, and secure the lower Cover-Open, Front.
3. Insert the Stud Cover into the hole at the top surface of the Cover-Open, Front, and secure the upper Cover-Open, Front.
4. Align the Cover-Front with the mounting position in the Finisher so that two bosses are engaged, and secure the Cover-Front together with the Stud Cover and Cover-Open, Front using four screws.
5. Secure the Cover-Open, Front to the Finisher with three screws.
6. Mount the Cover-Jogging.

## Switch Cover Front Removal

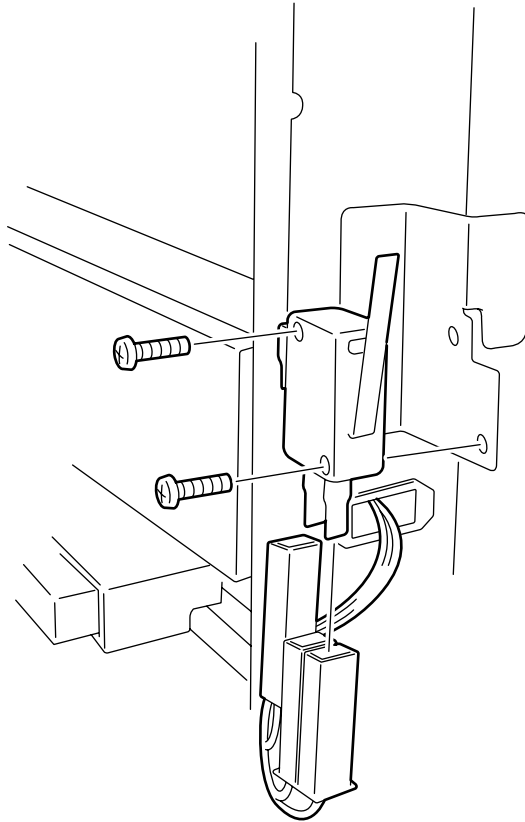

### Removal

1. Remove the Cover-Jogging.
2. Remove the Cover-Top, Front.
3. Remove the Cover-Open, Front, Cover-Front and Kit Stud Cover.
4. Unplug the connector (S2-1) of the Harness DC from the Switch Cover Front.
5. Remove two screws that secure the Finisher from the Switch Cover Front, and remove the Switch Cover Front.

### Replacement

1. Align the Switch Cover Front with the mounting position in the Finisher, and secure it with two screws.
2. Plug the connector (S2-1) of the Harness DC to the Switch Cover Front.
3. Mount the Cover-Open, Front, Cover-Front and Kit Stud Cover.
4. Mount the Cover-Top, Front.
5. Mount the Cover-Jogging.



## Latch Assembly and Switch Docking Removal

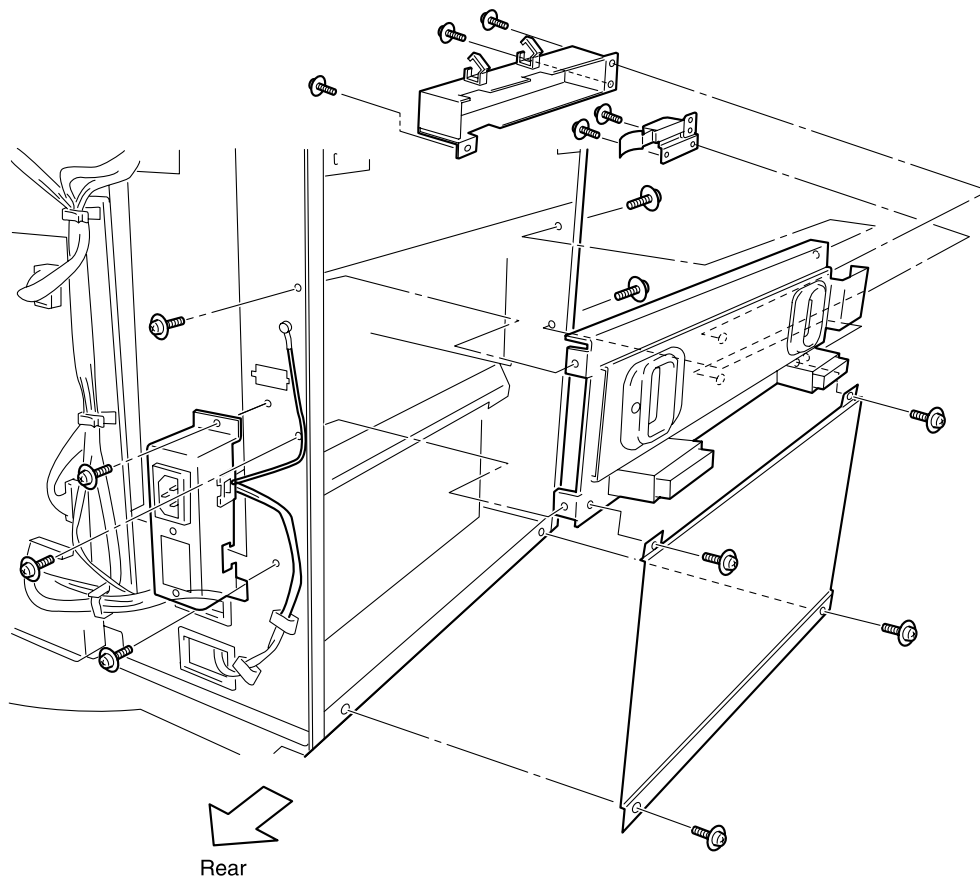

### Removal

1. Remove the Cover-Jogging.
2. Remove the Cover-Top, Front.
3. Remove the Cover-Rear.
4. Remove the Cover-Open, Front, Cover-Front and Kit Stud Cover.
5. Remove two screws that secure to the Finisher from the Bracket Inlet, and shift the Bracket Inlet together with the Inlet to the right direction.
6. Remove four screws that secure to the Finisher from the Cover Lower Left.
7. Remove four screws that secure to the Latch Assembly from the Cover Lower Left, and remove the Cover Lower Left.

**Note:** In the following steps, do not detach the Latch Assembly far away because the connector and harness are still connected.

8. Remove three screws of the Cover Switch Docking that secure to the back of the Latch Assembly, and remove the Cover Switch Docking.
9. Unhook the two Clamps, and release the harness.
10. Unplug the connector (S1-1) of the Harness Docking from the Switch Docking.
11. Remove two screws of the Switch Docking that secure to the back of the Latch Assembly, and remove the Switch Docking.

### Replacement

1. Align the Switch Docking with the mounting position in the Latch Assembly, and secure it with two screws.
2. Plug the connector (S1-1) of the Harness Docking to the Switch Docking.
3. Align the Cover Switch Docking with the mounting position in the Latch Assembly, and secure it with three screws.
4. Align the Latch Assembly with the mounting position in the Finisher, and secure it with four screws.
5. Align the Cover Lower Left with the mounting position in the Finisher, and secure it to the Latch Assembly with two screws.
6. Secure the Cover Lower Left to the Finisher with four screws.
7. Align the Bracket Inlet together with the Inlet, with the mounting position in the Finisher, and secure it with two screws.
8. Mount the Cover-Open, Front, Cover-Front and Kit Stud Cover.
9. Mount the Cover-Rear.
10. Mount the Cover-Top, Front.
11. Mount the Cover-Jogging.

## Kit H-Tra Bracket and Screw Removal

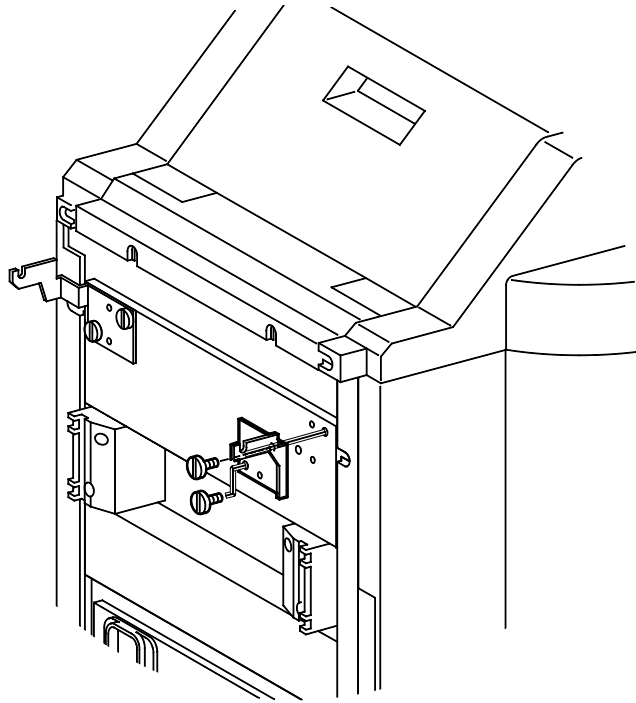

### Removal

1. Remove the Thumbscrews that secures Docking Bracket Front to the Finisher, and remove the Thumbscrews together with the Docking Bracket Front.
2. For the Docking Bracket Rear and Thumbscrews on the rear side, perform the above step in the same manner.

### Replacement

1. Align the Docking Bracket Front with the mounting position, and secure them with the Thumbscrews.
2. For the Docking Bracket Rear and Thumbscrews on the rear side, perform the above step in the same manner.

## Cover-Rear Removal

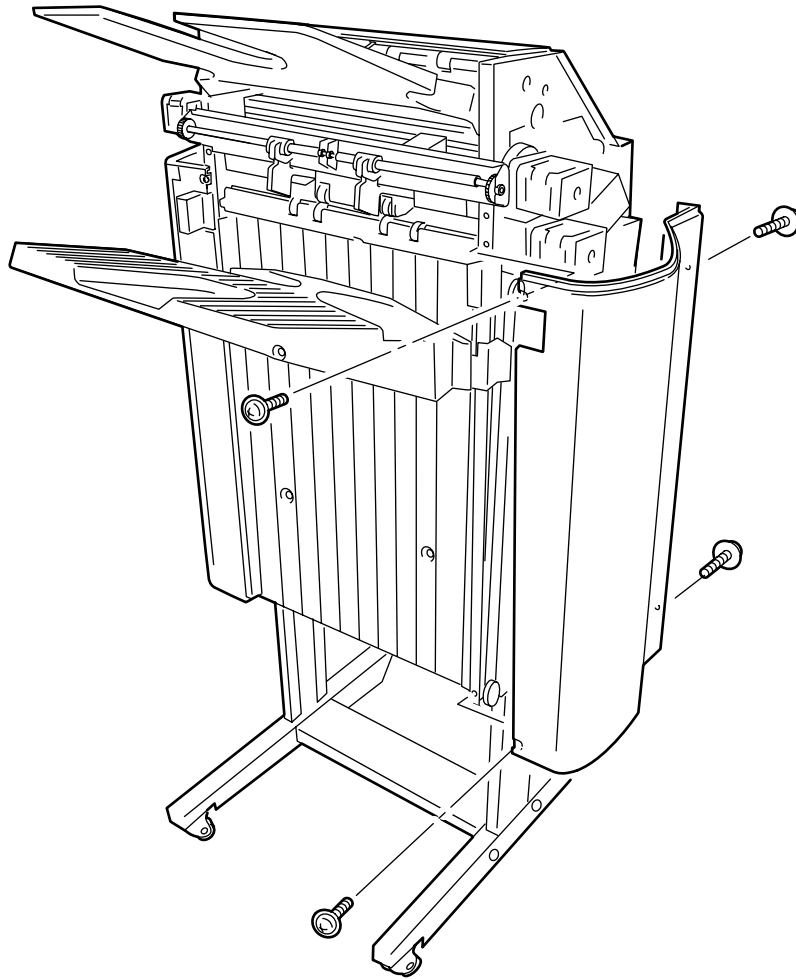

### Removal

1. Remove the Cover-Jogging.
2. Remove the Cover-Top, Front.
3. Remove the screws that secure to the Finisher from the Cover-Rear, and remove the Cover-Rear.

### Replacement

1. Align the Cover-Rear with the mounting position in the Finisher, and secure the Cover-Rear with the screws.
2. Mount the Cover-Top, Front.
3. Mount the Cover-Jogging.

## Cover-Top Left Removal

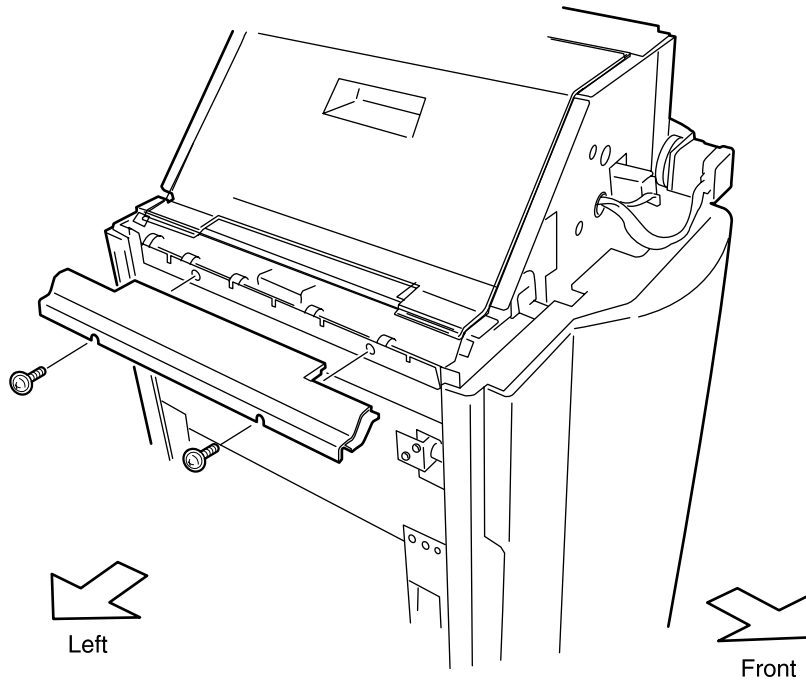

### Removal

1. Remove the Cover-Jogging.
2. Remove the Cover-Top, Front and Cover-Top, Rear.
3. Remove two screws that secure to the Finisher from the Cover-Top, Left, and remove the Cover-Top, Left.

### Replacement

1. Align the Cover-Top, Left with the mounting position in the Finisher, and secure it with two screws.
2. Mount the Cover-Top, Front and Cover-Top, Rear.
3. Mount the Cover-Jogging.

## Top Center Cover Assembly Removal

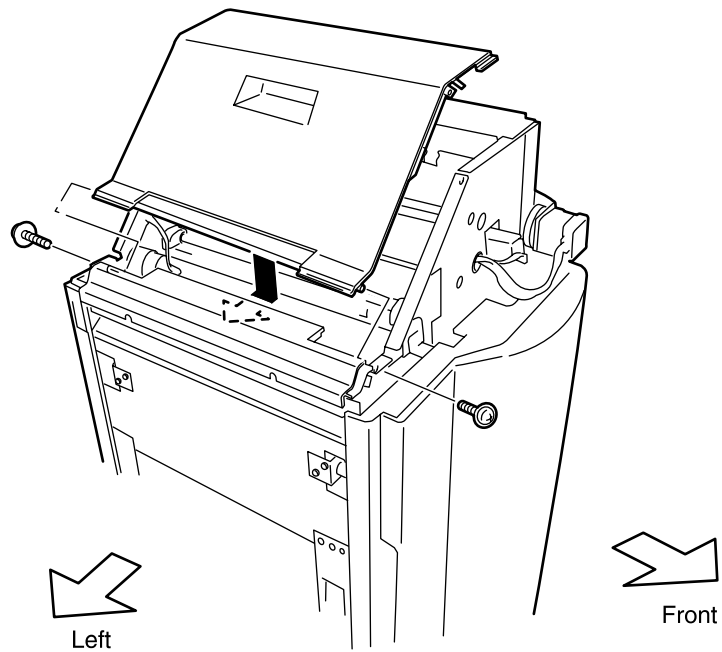

### Removal

1. Remove the Cover-Jogging.
2. Remove the Cover-Top, Front and Cover-Top, Rear.
3. Remove four screws that secure to the Finisher from the Top Center Cover Assembly, and remove the Top Center Cover Assembly.

### Replacement

1. Align the Top Center Cover Assembly with the mounting position in the Finisher, and secure it with four screws.
2. Mount the Cover-Top, Front and Cover-Top, Rear.
3. Mount the Cover-Jogging.

## Kit Bracket Assembly and Screw Removal

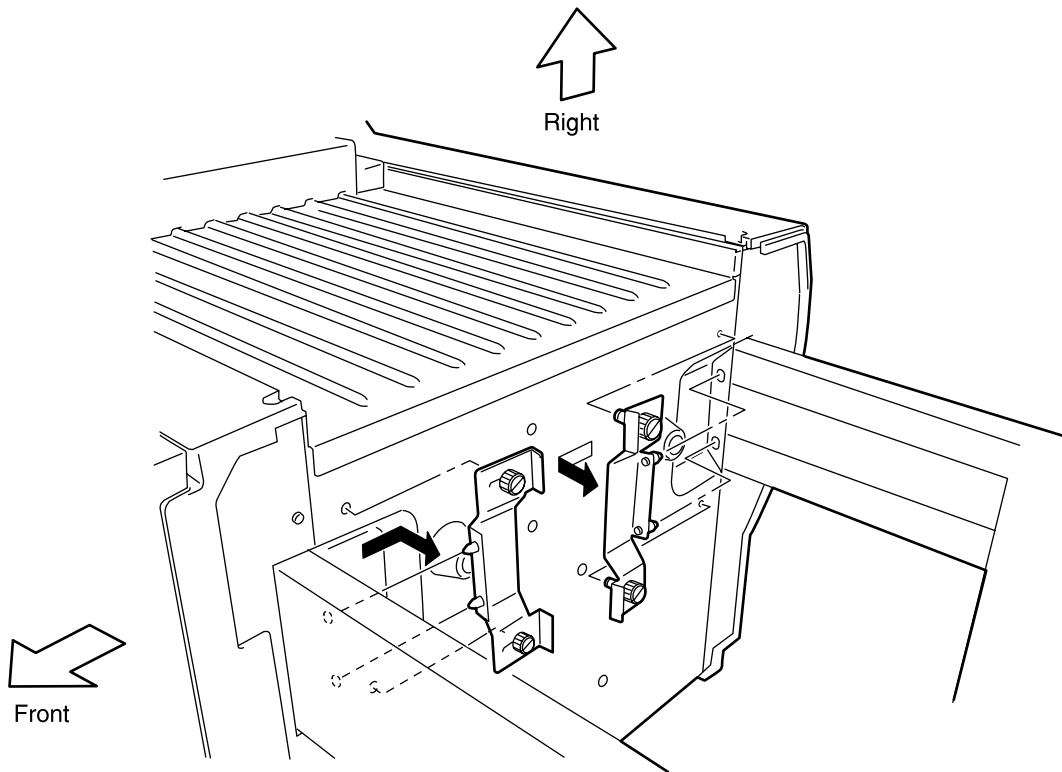

### Removal

1. Place several-ply cardboards or newspapers on the floor, and carefully tumble the Finisher from the left side.
2. Remove two Thumbscrews on the front side.
3. Sliding the Bracket Assembly on the front side toward the inside, remove the Bracket Assembly.
4. For the Bracket Assembly and Thumbscrews on the rear side, perform the above steps in the same manner.

### Replacement

**Note:** Align the holes on both front and rear sides of the Frame Post with the holes on both front and rear sides of the Finisher.

1. Align two pins on the front side of the Bracket Assembly with the holes in the Finisher.
2. Push in the Bracket Assembly on the front side up to the specified position, and secure it with two Thumbscrews.
3. For the Bracket Assembly and Thumbscrews on the rear side, perform the above steps in the same manner.
4. Erect the Finisher carefully.

## Frame Post Removal

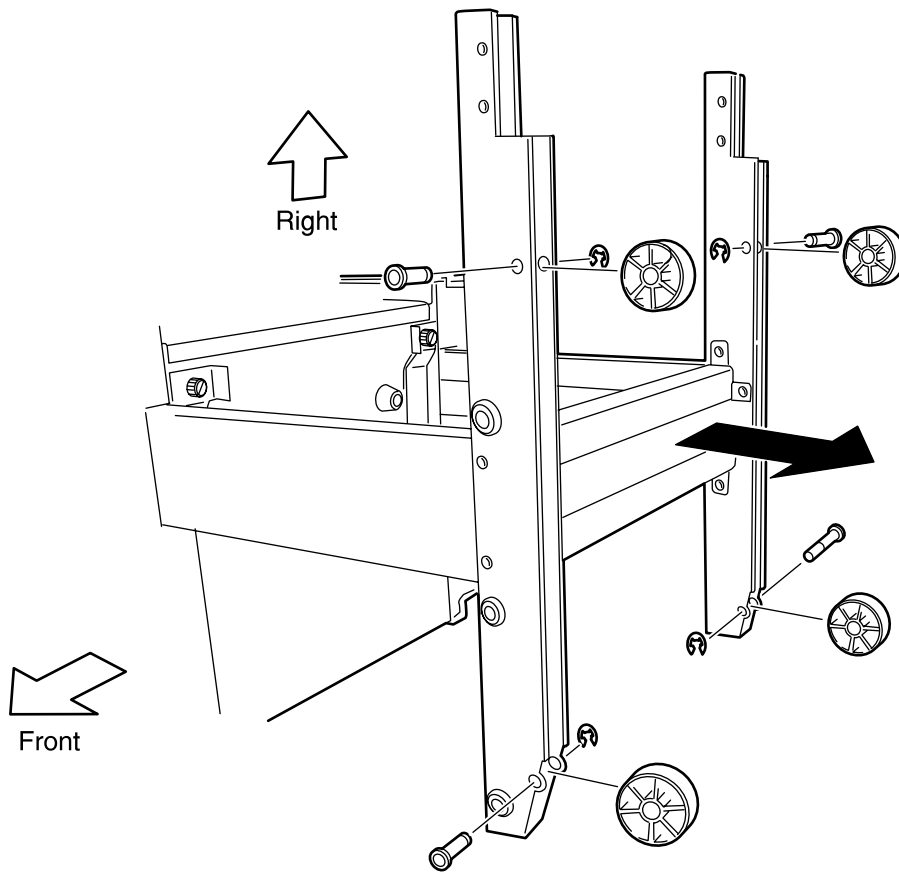

### Removal

1. Place several-ply cardboards or newspapers on the floor, and carefully tumble the Finisher from the left side.
2. Remove the Kit Bracket Assembly and Screw.
3. Remove the Cap-End.
4. Remove the Caster Assembly.
5. Remove E-rings that secure the Pin Right and Roll in the right and left sides of the front, and remove the Pin Right and Roll.
6. Remove the E-ring that secures the Pin Right and Roll, and remove the Pin Right and Roll.
7. Remove the E-ring that secures the Pin Left and Roll, and remove the Pin Left and Roll.
8. Pull the Frame Post off the Finisher.



## 4025-Finisher

### Replacement

1. Insert the Frame Post in parallel to the Finisher, and align four holes in the Frame Post with four holes in the Finisher.
2. Aligning the hole in the Roll with the shaft holes for the wheels located on the rear left side, insert the Pin Right from the rear side and secure it with an E-ring.
3. Aligning the hole in the Roll with the shaft holes for the wheels located on the rear right side, insert the Pin Right from the rear side and secure it with an E-ring.
4. Aligning the hole in the Roll with the shaft holes for the wheels located on the front right and left sides, insert the Pin Right from the rear side and secure it with an E-ring.
5. Mount the Caster Assembly.
6. Mount the Cap-End.
7. Mount the Kit Bracket Assembly and Screw.
8. Erect the Finisher carefully.

## Cap-End Removal

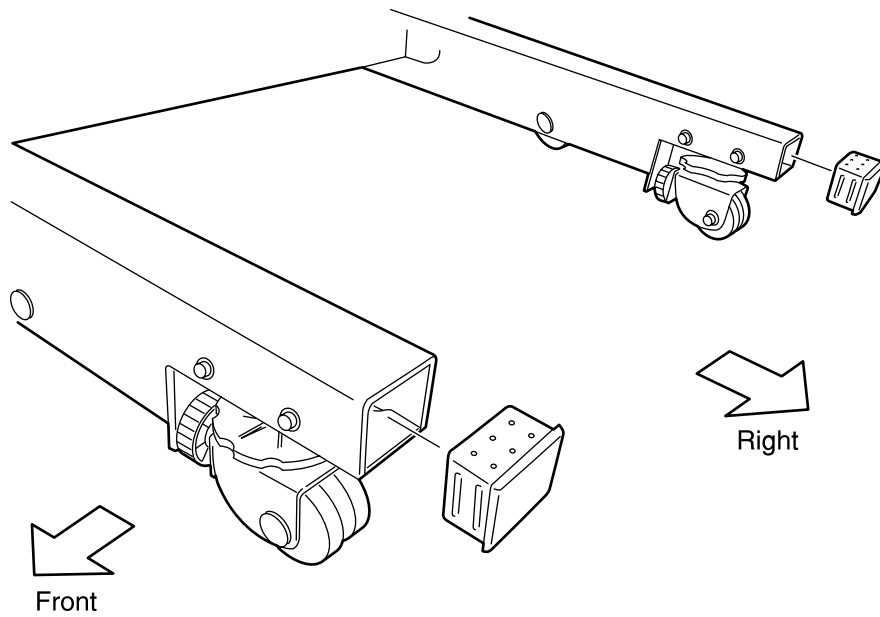

## Removal

1. Insert a small screwdriver between the Cap-End and Frame Post on the front side, and pull off the Cap-End.
2. For the rear side, perform the above step in the same manner.

## Replacement

1. Align the Cap-End with the mounting position in the Frame Post on the front side, and mount the Cap-End.
2. For the rear side, perform the above step in the same manner.

## Caster Assembly Removal

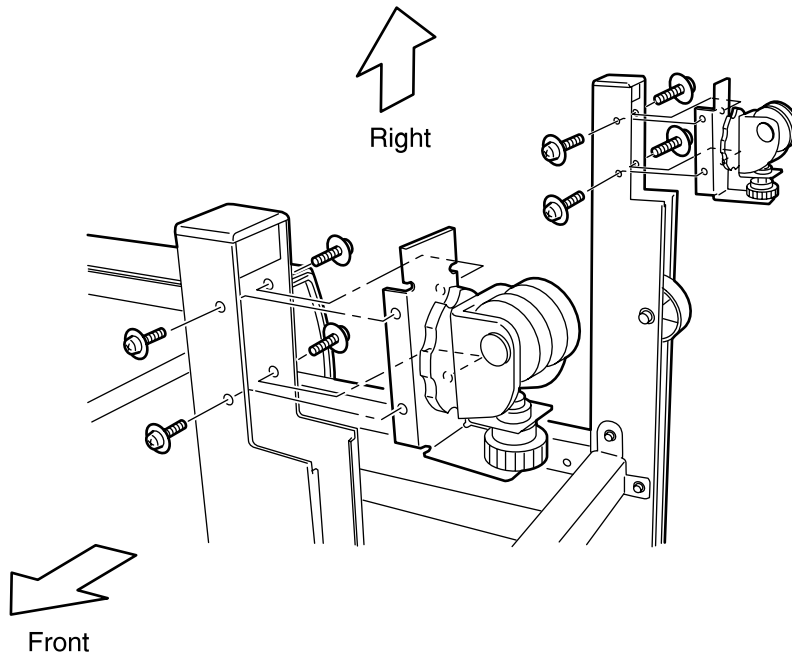

### Removal

1. Place several-ply cardboards or newspapers on the floor, and carefully tumble the Finisher from the left side.
2. Remove four screws that secure to the Frame Post from the Caster Assembly on the front side, and remove the Caster Assembly on the front side.
3. For the rear side, perform the above step in the same manner.

### Replacement

1. Align the Caster Assembly with the mounting position in the front side of the Frame Post, and secure it with four screws.
2. For the rear side, perform the above step in the same manner.
3. Erect the Finisher carefully.

## Lever Assembly Removal

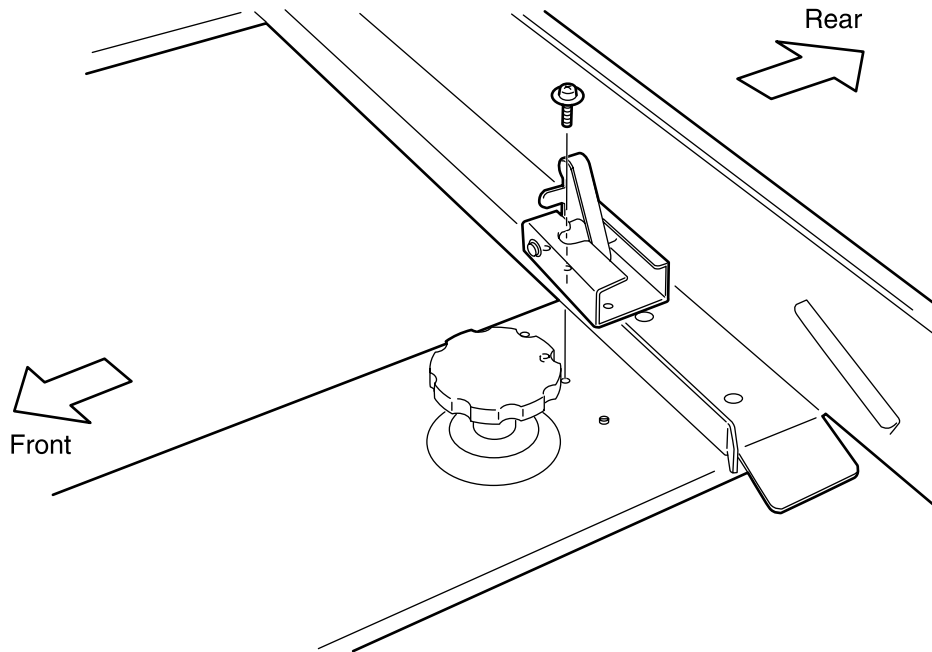

### Removal

Remove the screw that secures to the Rail from the Lever Assembly, and remove the Lever Assembly.

### Replacement

Align the Lever Assembly with the mounting position in the Rail, and secure it with a screw.

## Sensor, Input Path Removal

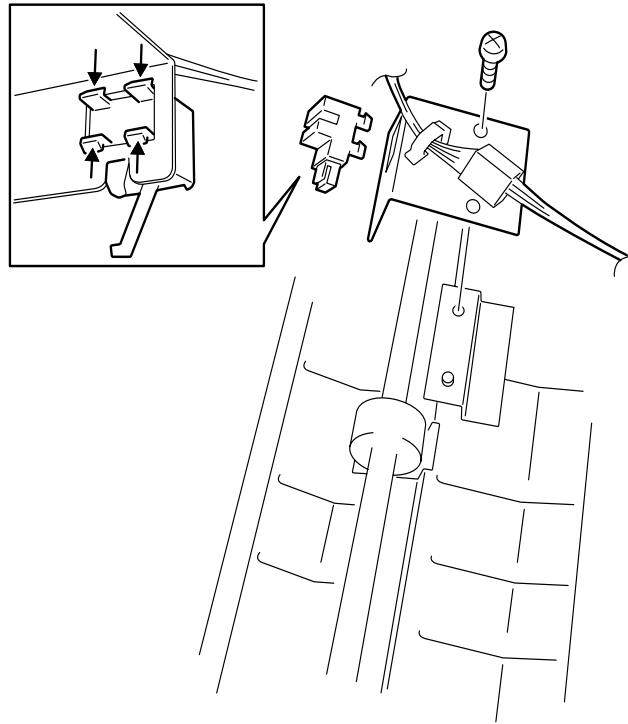

### Removal

1. Remove the Cover-Jogging.
2. Remove the Cover-Top, Front and Cover-Top, Rear.
3. Remove the Cover Top Left.
4. Remove the Top Center Cover Assembly.
5. Unplug the connector (P/J 1) of the Harness Sensor from the Sensor, Input Path.
6. Remove the screw that secures the Bracket-Sensor, and lift up the Bracket-Sensor together with the Sensor, Input Path and Clamp.
7. Unhook the Sensor, Input Path at four places, and remove the Sensor, Input Path.

### Replacement

1. Align the Sensor, Input Path with the mounting position in the Bracket-Sensor, and mount the Sensor, Input Path.
2. Align the Bracket-Sensor, together with the Sensor, Input Path and Clamp, with the mounting positions in the Finisher, and secure them with a screw.
3. Plug the connector (P/J 1) of the Harness Sensor to the Sensor, Input Path.
4. Mount the Top Center Cover Assembly.
5. Mount the Cover Top Left.
6. Mount the Cover-Top, Front and Cover-Top, Rear.
7. Mount the Cover-Jogging.

## Sensor, Exit Path Removal

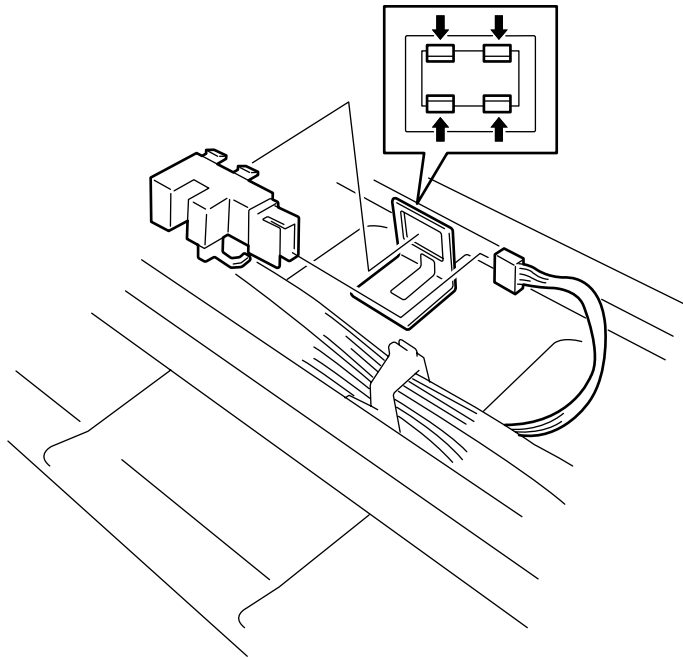

### Removal

1. Remove the Cover-Jogging.
2. Remove the Cover-Top, Front and Cover-Top, Rear.
3. Unplug the connector (P/J 4) of the Harness Sensor from the Sensor, Exit Path.
4. Unhook the Sensor, Exit Path at four places, and remove the Sensor, Exit Path.

### Replacement

1. Align the Sensor, Exit Path with the mounting position in the Finisher, and mount the Sensor, Exit Path.
2. Plug the connector (P/J 4) of the Harness Sensor to the Sensor, Exit Path.
3. Mount the Sensor Assembly.
4. Mount the Cover-Top, Front and Cover-Top, Rear.
5. Mount the Cover-Jogging.

## Roll Assembly-REGI Removal

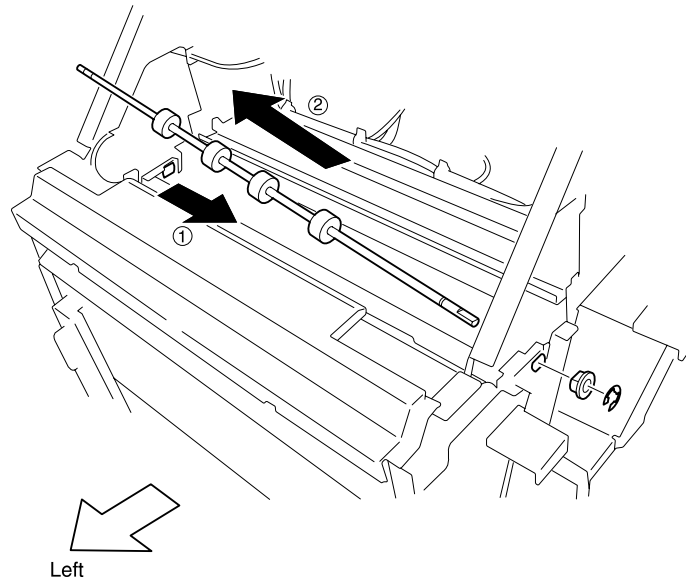

### Removal

1. Remove the Cover-Jogging.
2. Remove the Cover-Top, Front and Cover-Top, Rear.
3. Remove the Top Center Cover Assembly.
4. Remove the Cover-Open, Front, Cover-Front and Kit Stud Cover.
5. Remove the Knob, Regi Roller.
6. Remove the Puncher.
7. Remove the Guide Assembly-Dust.
8. Remove the Bearing that secures the shaft on the front side of the Roll Assembly-REGI.
9. Slide the Roll Assembly-REGI toward the front (1), and lifting up the shaft on the rear side pull it off in a diagonal upward direction. (2)

### Replacement

1. From the inside of the Finisher, insert the shaft on the front side of the Roll Assembly-REGI into the mounting hole.
2. From the inside of the Finisher, insert the shaft on the rear side of the Roll Assembly-REGI into the mounting hole, and secure the shaft on the front side of the Roll Assembly-REGI with the Bearing.
3. Mount the Guide Assembly-Dust.
4. Mount the Puncher.
5. Mount the Knob, Regi Roller.
6. Mount the Cover-Open, Front, Cover-Front and Kit Stud Cover.
7. Mount the Top Center Cover Assembly.
8. Mount the Cover-Top, Front and Cover-Top, Rear.
9. Mount the Cover-Jogging.

## Roll Transport Removal

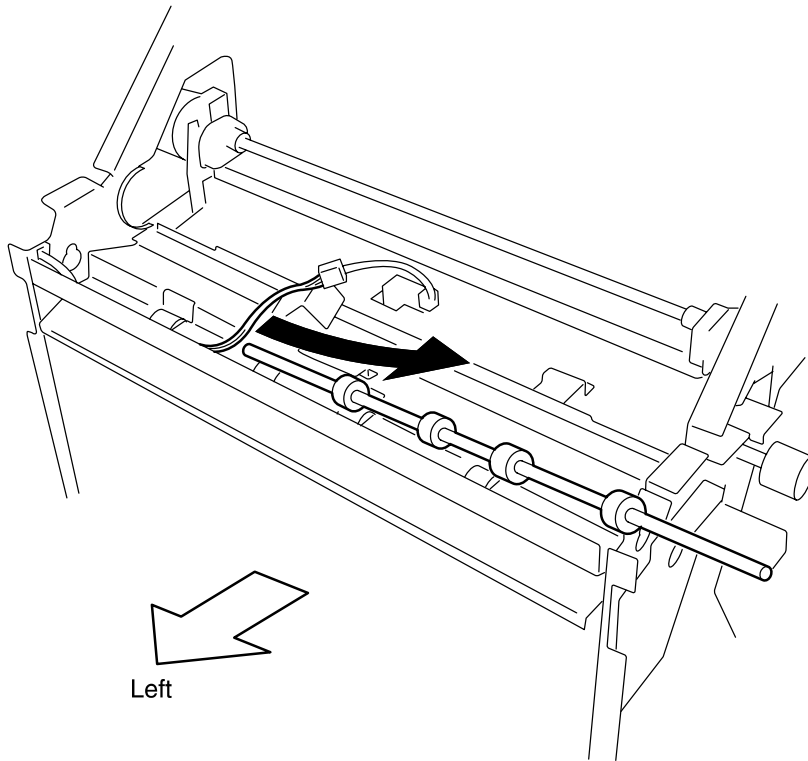

### Removal

1. Remove the Cover-Jogging.
2. Remove the Cover-Top, Front and Cover-Top, Rear.
3. Remove the Cover-Open, Front, Cover-Front and Kit Stud Cover.
4. Remove the Cover-Rear.
5. Remove the Cover Top Left.
6. Remove the Top Center Cover Assembly.
7. Remove the Sensor, Input Path.
8. Remove the Kit Drive Assembly.
9. Remove the Bearing that secures the shaft on the front side of the Roll Transport.

**WARNING:** In the following steps, take care not to allow the harness to get stuck to the roller.

10. Lift up the Roll Transport a little, and move it toward the rear so that the leading end of the shaft on the front side enters into the inside of the Finisher frame.
11. Lift up the shaft on the front side of the Roll Transport, and pull it off.



### Replacement

**WARNING:** In the following steps, take care not to allow the harness to get stuck to the roller.

1. Let the shaft on the rear side of the Roll Transport through under the harness of the Finisher, and insert it into the bearing on the rear side.
2. Insert the shaft on the front side of the Roll Transport into the bearing on the front side of the Finisher, and secure it with the Bearing.
3. Mount the Kit Drive Assembly.
4. Mount the Sensor, Input Path.
5. Mount the Top Center Cover Assembly.
6. Mount the Cover Top Left.
7. Mount the Cover-Rear.
8. Mount the Cover-Open, Front, Cover-Front and Kit Stud Cover.
9. Mount the Cover-Top, Front and Cover-Top, Rear.
10. Mount the Cover-Jogging.

## Kit Drive Assembly Removal

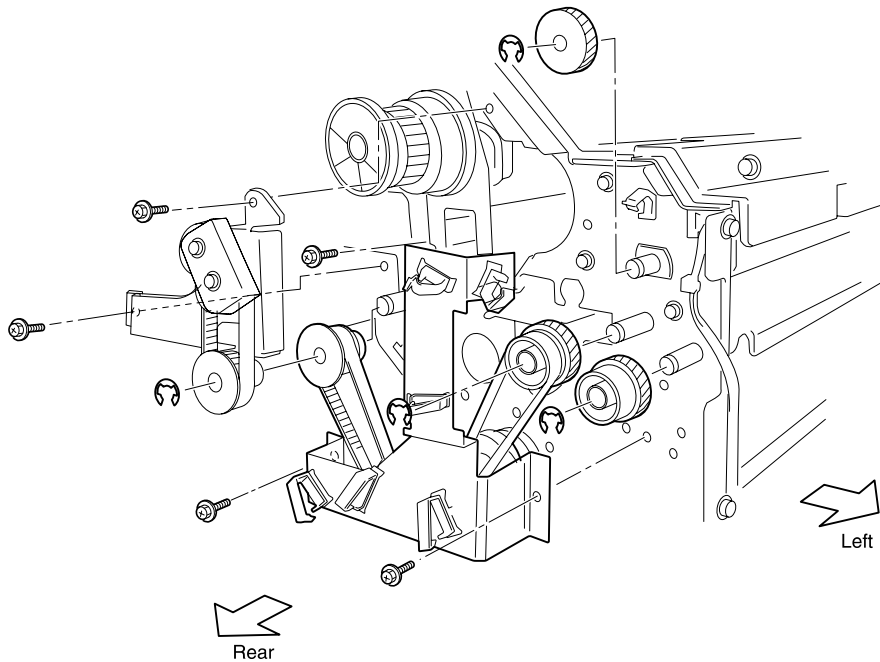

### Removal

1. Remove the Cover-Jogging.
2. Remove the Cover-Top, Front and Cover-Top, Rear.
3. Remove the Cover-Rear.
4. Unclamp the harness at six places on the Drive Assembly.
5. Remove the E-ring that secures two Gear and Gear to the Roll Assembly-REGI.
6. Remove two screws that secure to the Finisher from the Gear and Belt Assembly, and remove the Gear and Belt Assembly together with the Gear.
7. Remove the E-ring that secures the Flange and Gear to the shaft of the Finisher.
8. Remove three screws that secure to the Finisher from the Drive Assembly, and remove the Drive Assembly together with the Flange, Gear, Gear.

## 4025-Finisher

### Replacement

1. Insert the Flange and Gear into the Finisher, and secure it with an E-ring.
2. Insert the Gear into the shaft of the Roll Assembly-REGI.
3. Engage the belt on the right side of the Drive Assembly to the Gear, and also engage the belt on the left side of the Drive Assembly to the Gear.
4. Align the Drive Assembly with the mounting position in the Finisher, and secure it with three screws.
5. Insert the Gear into the shaft of the Roll Assembly-REGI, securing it with an E-ring.
6. Engage the belt of the Gear and Belt Assembly to the Gear, and align the Gear and Belt Assembly with the mounting position in the Finisher, then secure it with three screws.
7. Clamp the harness at six places on the Drive Assembly.
8. Mount the Cover-Rear.
9. Mount the Cover-Top, Front and Cover-Top, Rear.
10. Mount the Cover-Jogging.

## Chute Assembly-Inlet Removal

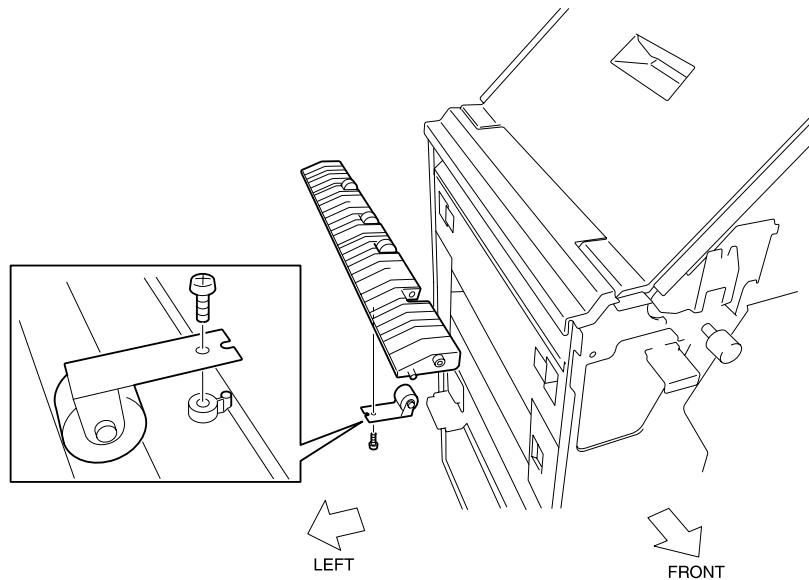

### Removal

1. Remove the Cover-Jogging.
2. Remove the Cover-Top, Front and Cover-Top, Rear.
3. Remove the Cover-Rear.
4. Remove the Cover-Open, Front, Cover-Front and Kit Stud Cover.
5. Remove two screws that secure to the Finisher from the Chute Assembly-Inlet.
6. Pull the Chute Assembly-Inlet off the Finisher toward the left.

### Replacement

1. Insert the Chute Assembly-Inlet from the left side of the Finisher, and align it with the mounting position.
2. Secure the Chute Assembly-Inlet with two screws.
3. Mount the Cover-Open, Front, Cover-Front and Kit Stud Cover.
4. Mount the Cover-Rear.
5. Mount the Cover-Top, Front and Cover-Top, Rear.
6. Mount the Cover-Jogging.

## Kit Invert Guide Removal

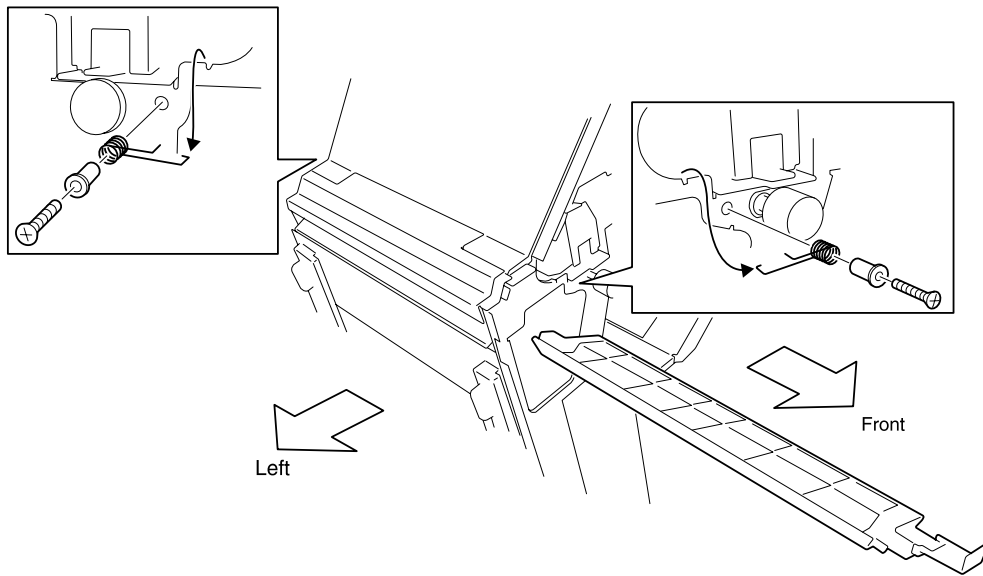

### Removal

1. Remove the Cover-Jogging.
2. Remove the Cover-Top, Front and Cover-Top, Rear.
3. Remove the Cover-Rear.
4. Remove the Cover-Open, Front, Cover-Front and Kit Stud Cover.
5. Remove the screw that secures the Invert Guide Assembly, Stud and Spring on the rear side, and remove the Stud and Spring while unhooking the Spring from the notch of the Finisher frame.

**WARNING:** In the following steps, the Invert Guide Assembly is not secured. Take care not to drop or damage it.

6. Remove the screw that secures the Invert Guide Assembly, Spring and Screw on the front side, and remove the Stud and Spring while unhooking the Stud from the notch of the Finisher frame.
7. From the front side of the Finisher, remove the Invert Guide Assembly toward the front.

## 4025-Finisher

### Replacement

1. Insert the Stud from the short hook side of the Spring.
2. Insert the Invert Guide Assembly from the front side of the Finisher, align it with the mounting position.
3. Engaging the long hook of the Spring with the notch of the Finisher frame, engage the short hook of the Spring with the concave of the Invert Guide Assembly, and secure the Invert Guide Assembly, Spring and Stud on the front side to the Finisher.
4. On the rear side, engaging the long hook of the Spring with the notch of the Finisher frame, engage the short hook of the Stud with the concave of the Invert Guide Assembly, and secure the Invert Guide Assembly, Stud and Spring on the rear side to the Finisher.
5. Mount the Cover-Open, Front, Cover-Front and Kit Stud Cover.
6. Mount the Cover-Rear.
7. Mount the Cover-Top, Front and Cover-Top, Rear.
8. Mount the Cover-Jogging.

### Kit Buffer Chute Removal

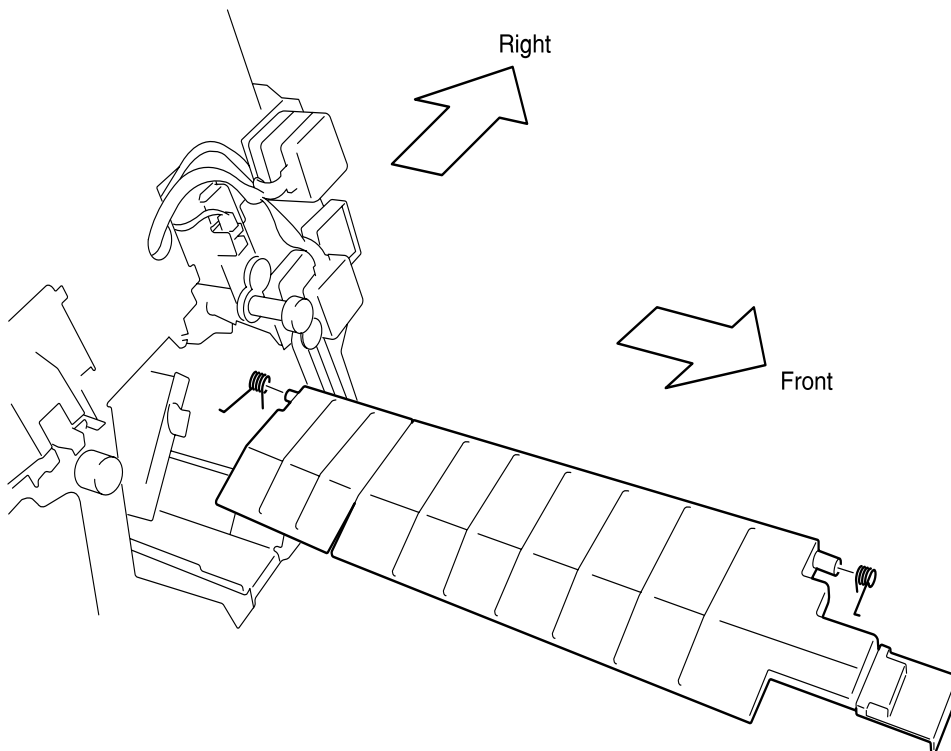
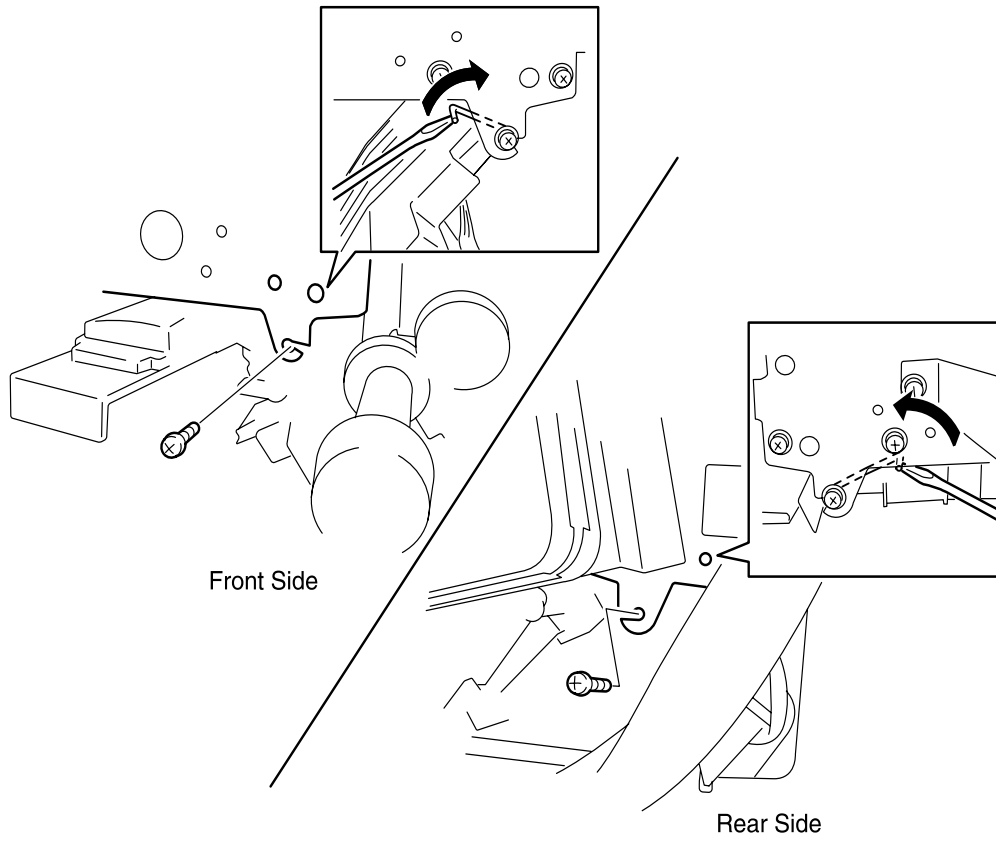

## 4025-Finisher

### Removal

1. Remove the Cover-Jogging.
2. Remove the Cover-Top, Front and Cover-Top, Rear.
3. Remove the Cover-Rear.
4. Remove the Cover-Open, Front, Cover-Front and Kit Stud Cover.
5. Unhook the Spring from the hole in the frame on the front of the Finisher.
6. Unhook the Spring from the hole in the frame on the rear of the Finisher.
7. Remove the screw that secures the rear of the Chute-Buffer Assembly.

**WARNING:** In the following steps, the Springs are not secured and easily removed from the shaft of the Chute-Buffer Assembly. Take care not to drop or damage them.

8. Remove the screw that secures the front of the Chute-Buffer Assembly, and remove the Chute-Buffer Assembly together with the Springs toward the front. (Figure 2)
9. Remove two Springs from the shafts of both sides of the Chute-Buffer Assembly.

### Replacement

1. Insert the Spring into the shaft on the rear of the Chute-Buffer Assembly so that the straight hook is on the inside. (Figure 2)

**WARNING:** In the following steps, the Springs are easily removed from the shafts. Take care not to drop or damage them.

2. From the front, insert the Chute-Buffer Assembly together with the Springs into the inside of the Finisher, and align them with the mounting positions.
3. Secure the front of the Chute-Buffer Assembly together with the Spring with a screw. (Figure 1)
4. Secure the rear of the Chute-Buffer Assembly together with the Spring with a screw. (Figure 1)
5. Hook the Spring to the hole in the frame on the rear of the Finisher with a small screwdriver.
6. Hook the Spring to the hole in the frame on the front of the Finisher with a small screwdriver.
7. Mount the Cover-Open, Front, Cover-Front and Kit Stud Cover.
8. Mount the Cover-Rear.
9. Mount the Cover-Top, Front and Cover-Top, Rear.
10. Mount the Cover-Jogging.



## Knob, Regi Roller Removal

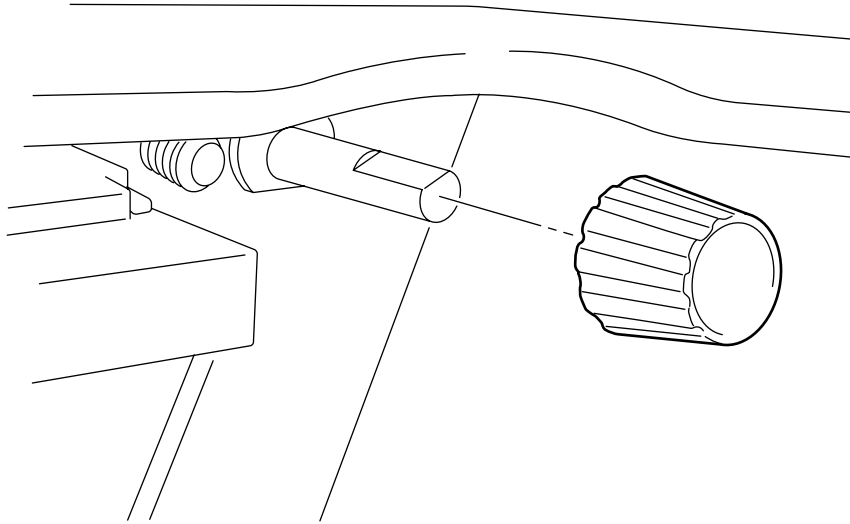

### Removal

1. Open the Cover-Rear.
2. Pull off the Knob, Regi Roller.

### Replacement

1. Insert the Knob, Regi Roller onto the shaft of the Roll Assembly-REGI.
2. Close the Cover-Rear.

## Transport Motor Assembly Removal

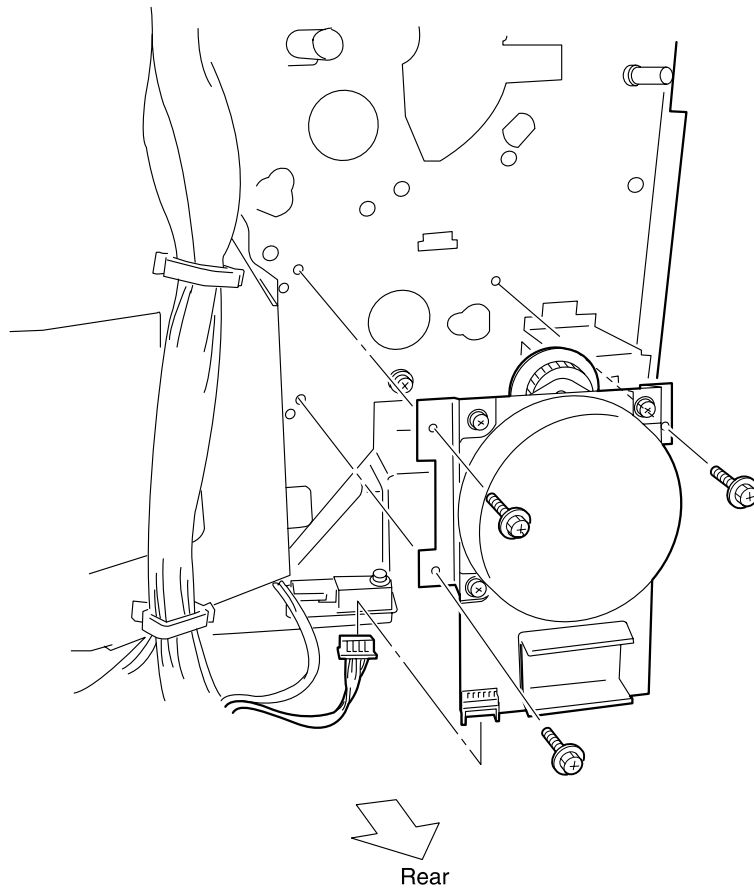

### Removal

1. Remove the Cover-Jogging.
2. Remove the Cover-Top, Front and Cover-Top, Rear.
3. Remove the Cover-Rear.
4. Remove the Kit Drive Assembly.
5. Unplug the connector (CN 1) of the Harness Motor from the Transport Motor Assembly.
6. Remove four screws that secure to the Finisher from the Transport Motor Assembly, and remove the Transport Motor Assembly.

### Replacement

1. Align the Transport Motor Assembly with the mounting position, and secure it with four screws.
2. Plug the connector (CN 1) of the Harness Motor to the Transport Motor Assembly.
3. Mount the Kit Drive Assembly.
4. Mount the Cover-Rear.
5. Mount the Cover-Top, Front and Cover-Top, Rear.
6. Mount the Cover-Jogging.

## Puncher Removal

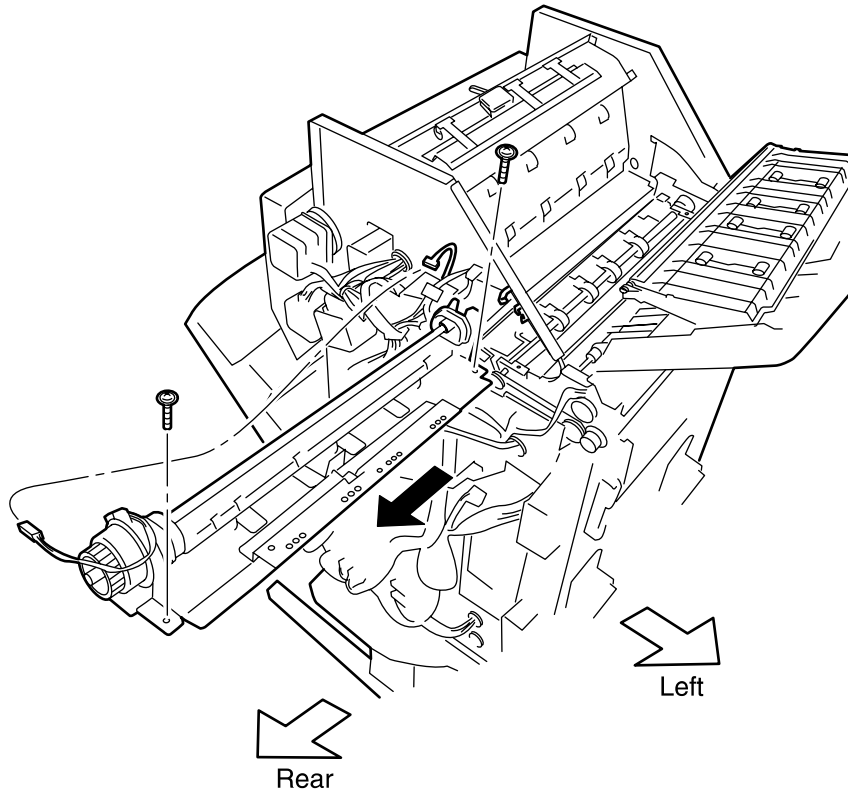

## 4025-Finisher

### Removal

1. Remove the Cover-Jogging.
2. Remove the Cover-Top, Front and Cover-Top, Rear.
3. Remove the Cover-Rear.
4. Remove the Kit Roll Pinch.
5. Remove the Sensor, Path.
6. Unplug the connector (CN 18) of the Harness Motor from the Clutch of the Puncher.
7. Unclamp the harness of the Puncher at two places on the Finisher.
8. Remove two screws from the Puncher that secure the Finisher.
9. Lift up the Puncher a little, and move it to the rear to remove it.

### Replacement

1. Insert the Puncher from the rear, and align it with the mounting position.
2. Secure the Puncher to the Finisher with two screws.
3. Clamp the harness of the Puncher at two places on the Finisher.
4. Plug the connector (CN 18) of the Harness Motor to the Clutch of the Puncher.
5. Mount the Sensor, Path.
6. Mount the Kit Roll Pinch.
7. Mount the Cover-Rear.
8. Mount the Cover-Top, Front and Cover-Top, Rear.
9. Mount the Cover-Jogging.

## Kit Roll Pinch Removal

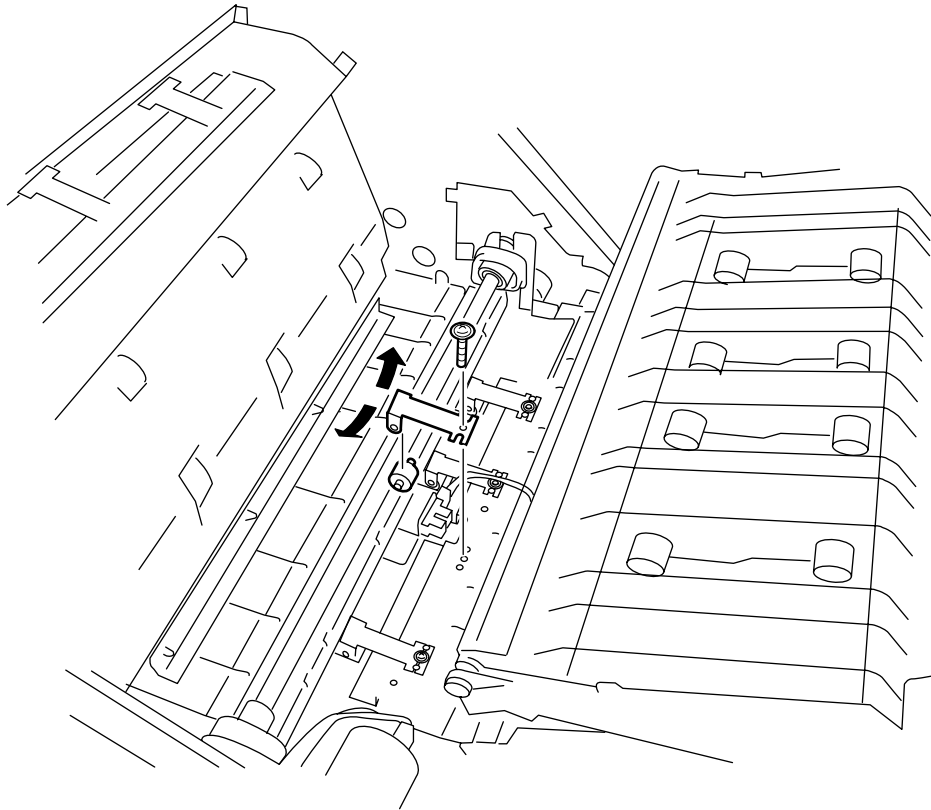

### Removal

1. Open the Top Center Cover Assembly.
2. Remove the screw that secures to the Finisher from the Pinch Roll, and remove the Pinch Roll and Spring Plate.
3. Loosen the bracket of the Pinch Roll, and remove the roller of the Pinch Roll.
4. Repeat step 3 until you have removed all, or the necessary, rollers of the Kit Roll Pinch.

### Replacement

1. Loosen the bracket of the Pinch Roll, and mount the roller of the Pinch Roll.
2. Align the Pinch Roll and Spring Plate with the mounting position in the Finisher, and secure it with a screw.
3. Repeat the above steps until you have mounted all the Kit Roll Pinch.
4. Close the Top Center Cover Assembly.

## Sensor, Path Removal

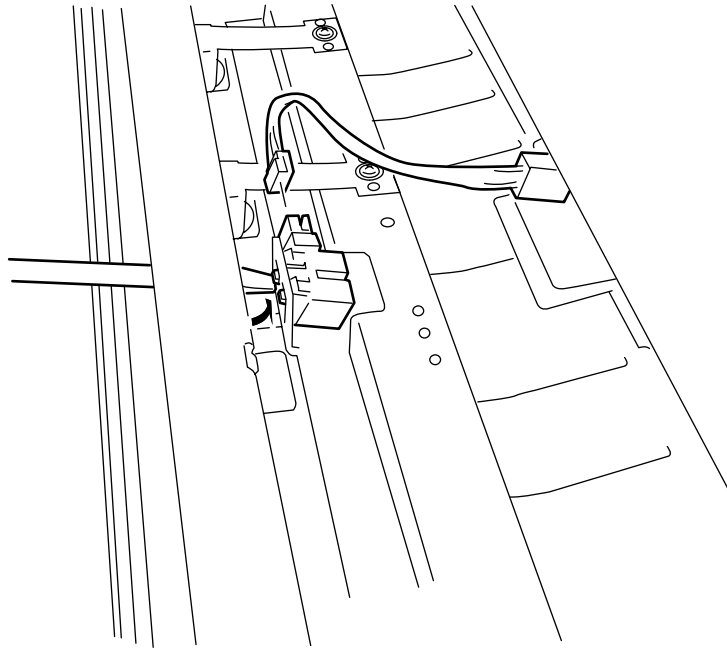

### Removal

1. Open the Top Center Cover Assembly.
2. Remove the second Kit Roll Pinch from the rear.
3. Unplug the connector (P/J 2) of the Harness Sensor from the Sensor, Path.
4. Pressing the leading end of the Sensor, Path downward with your finger, disengage two hooks on the upper side by pushing with a small screwdriver.
5. Disengage two hooks on the lower side of the Sensor, Path by pushing with a small screwdriver, and remove the Sensor, Path.

### Replacement

1. Align the Sensor, Path with the mounting position in the Finisher so that the connector faces toward the rear, and hook it at four places.
2. Plug the connector (P/J 2) of the Harness Sensor to the Sensor, Path.
3. Mount the second Kit Roll Pinch from the rear.
4. Close the Top Center Cover Assembly.

## Guide Assembly-Dust Removal

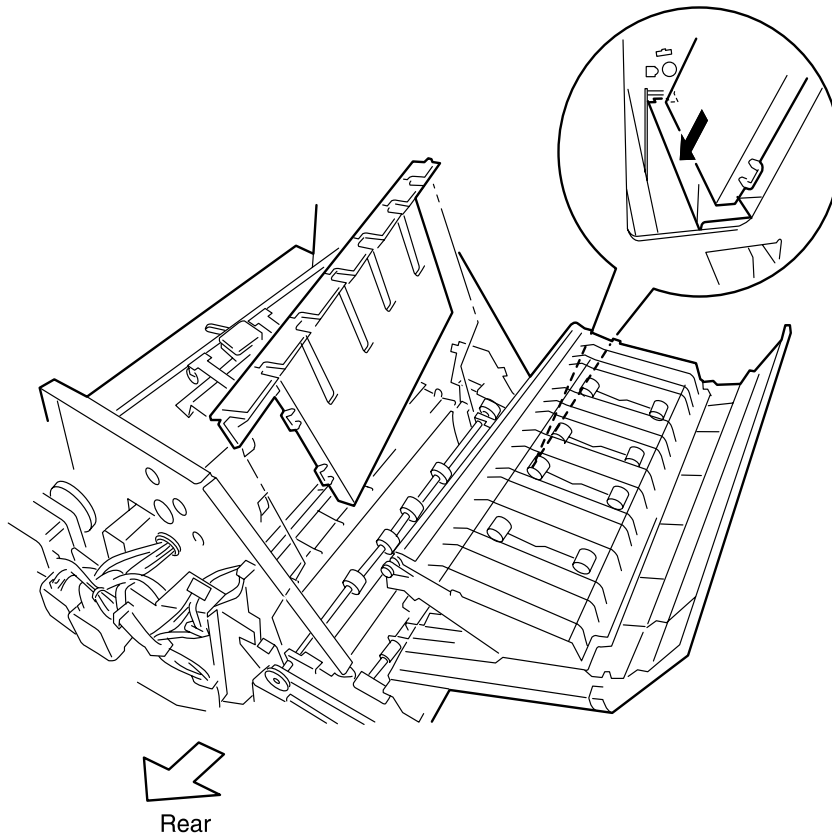

### Removal

1. Remove the Cover-Jogging.
2. Remove the Cover-Top, Front and Cover-Top, Rear.
3. Remove the Cover-Rear.
4. Remove the Kit Roll Pinch.
5. Remove the Sensor, Path.
6. Remove the Puncher.
7. Lift up the Guide Assembly-Dust a little, pull it off the notch of the Finisher frame, and tilt the Guide Assembly-Dust to remove them upward.

### Replacement

1. Tilt the Guide Assembly-Dust and insert it into the Finisher from the rear, and align two bosses of the Guide Assembly-Dust with the notch of the Finisher to mount them.
2. Mount the Puncher.
3. Mount the Sensor, Path and mount the Kit Roll Pinch.
4. Mount the Cover-Rear.
5. Mount the Cover-Top, Front and Cover-Top, Rear.
6. Mount the Cover-Jogging.

## Bottle Assembly-Dust Removal

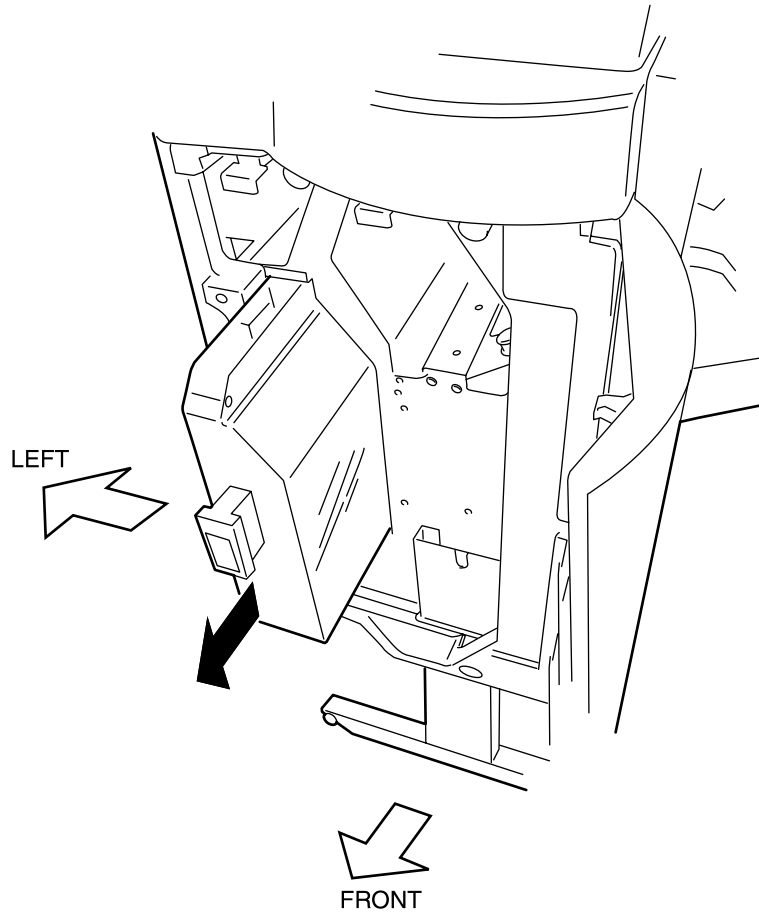

### Removal

1. Open the Cover-Open, Front.
2. Pull off the Bottle Assembly-Dust.

### Replacement

1. Insert the Bottle Assembly-Dust into the Finisher.
2. Close the Cover-Open, Front.



## Sensor Dust-Assembly Removal

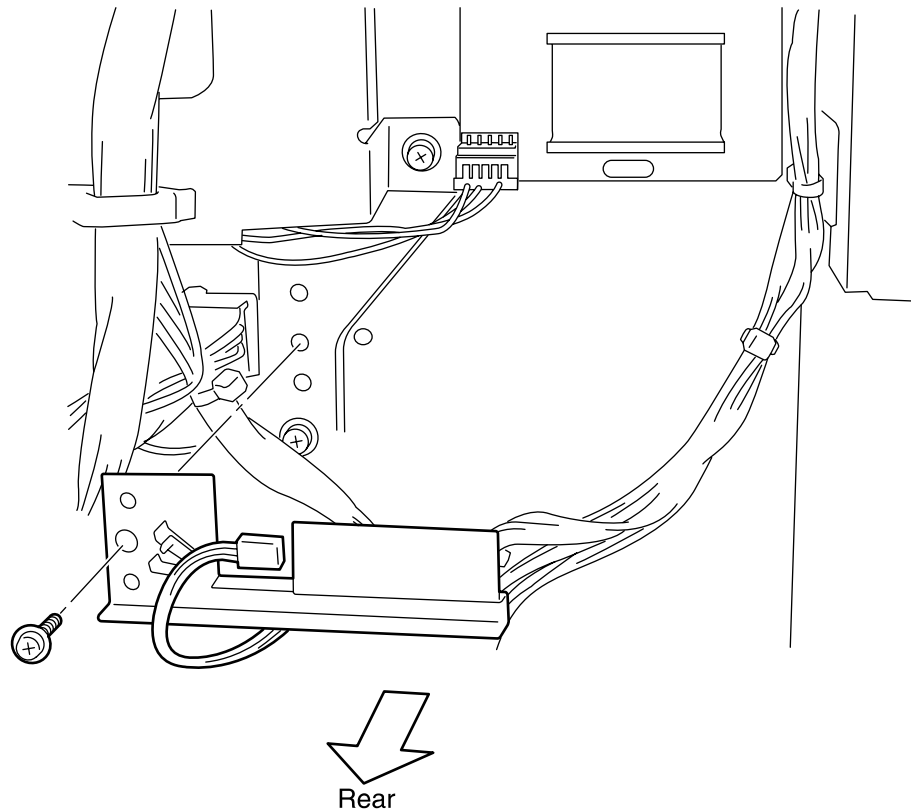

### Removal

1. Remove the Cover-Jogging.
2. Remove the Cover-Top, Front and Cover-Top, Rear.
3. Remove the Cover-Rear.
4. Unplug the connector (P/J 18) of the Harness H-Tra from the Sensor Dust Assembly.
5. Remove the screw that secures to the Finisher from the Sensor Dust Assembly, and remove the Sensor Dust Assembly.

### Replacement

1. Align the Sensor Dust Assembly with the mounting position, and secure it with a screw.
2. Plug the connector (P/J 18) of the Harness H-Tra to the Sensor Dust Assembly.
3. Mount the Cover-Rear.
4. Mount the Cover-Top, Front and Cover-Top, Rear.
5. Mount the Cover-Jogging.

## Inner Cover Removal

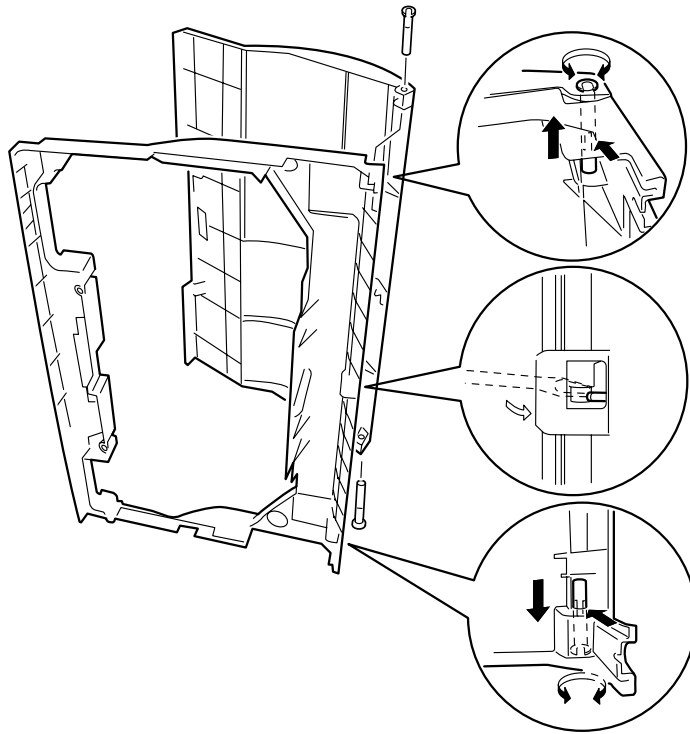

## Removal

1. Open the Cover-Open, Front.
2. Remove the Bottle Assembly-Dust.
3. Remove the Cover-Jogging.
4. Remove the Cover-Top, Front and Cover-Top, Rear.
5. Remove the Cover-Rear.
6. Remove two screws on the front that secure to the Finisher from the Inner Cover.
7. Remove four screws that secure to the Finisher from the PWB Chassis, and shift aside the PWB Chassis together with the PWB Assembly-Main toward the front.
8. Remove two screws on the rear that secure to the Finisher from the Inner Cover.
9. Release the harness of the stapler from the clamp of the Inner Cover, and remove the Inner Cover from the Finisher.

## Replacement

1. Align the Inner Cover with the mounting position in the Finisher, and bundle the harness of the stapler with the clamp of the Inner Cover.
2. Shifting aside the PWB Chassis together with the PWB Assembly-Main toward the front, secure the rear of the Inner Cover to the Finisher with two screws.
3. Secure the front of the Inner Cover to the Finisher with two screws.
4. Align the PWB Chassis, together with the PWB Assembly-Main, with the mounting position in the Finisher, and secure them with four screws.
5. Mount the Cover-Rear.
6. Mount the Cover-Top, Front and Cover-Top, Rear.
7. Mount the Cover-Jogging.
8. Mount the Bottle Assembly-Dust.
9. Close the Cover-Open, Front.

## Sensor Bottle Kit Removal

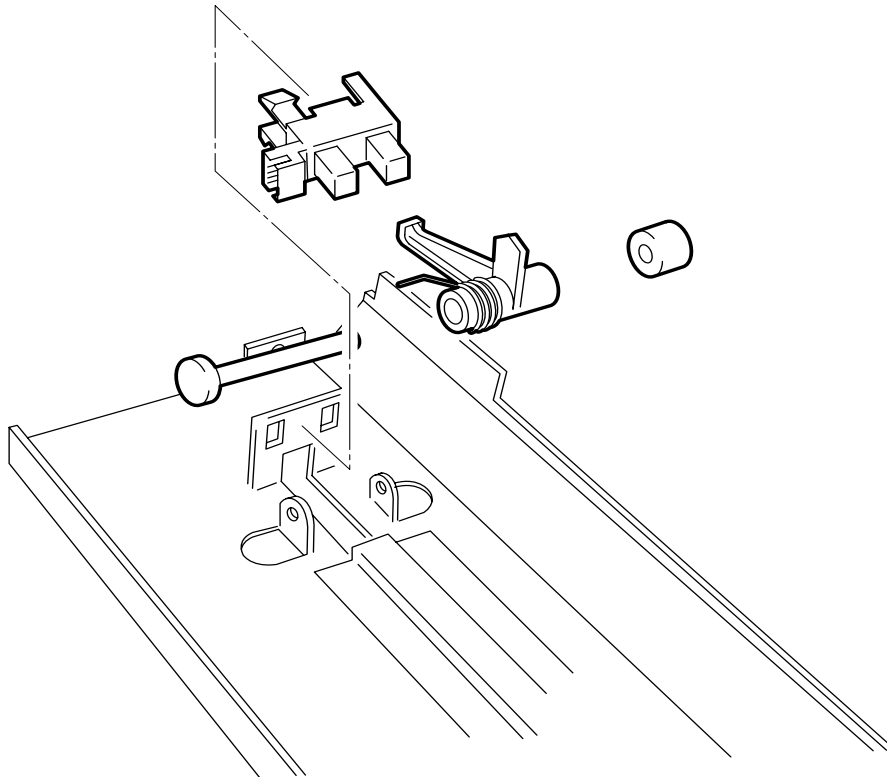
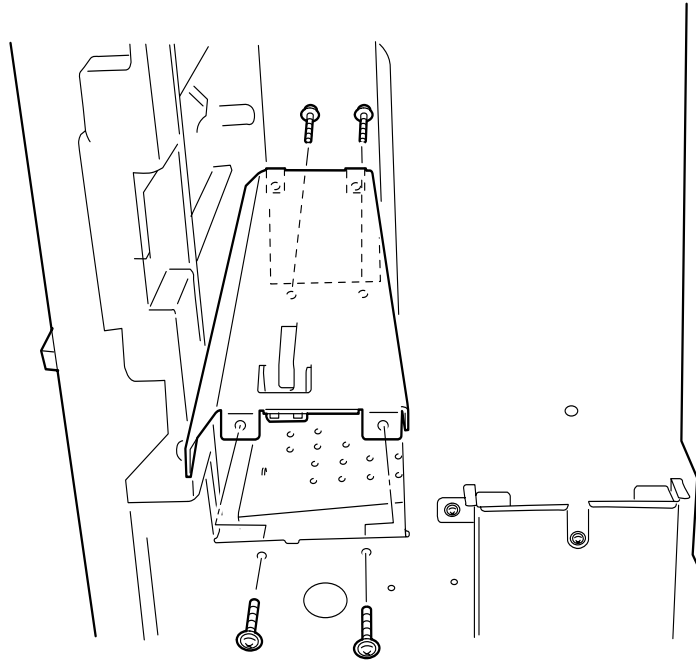

### Removal

1. Remove the Cover-Jogging.
2. Remove the Cover-Top, Rear.
3. Remove the Cover-Rear.
4. Open the Cover-Open, Front.
5. Remove the Bottle Assembly-Dust.

**WARNING:** In the following steps, do not detach the frame metal (provisional) far away because the connector (P/J 14) of the Photo Sensor is still connected to the frame metal (provisional).

6. Remove four screws that secure to the Finisher from the frame metal (provisional), and lift a little the frame metal (provisional) together with the Sensor Bottle Kit.
7. Unplug the connector (P/J 14) of the Photo Sensor on the back of the frame metal (provisional). (Figure 2)
8. Invert the frame metal (provisional), and pull off the Actuator Cap that secures the Spring and the Actuator.
9. Pull off the Shaft and remove the Spring and Actuator.
10. Unhook the Photo Sensor at three places, and remove the Photo Sensor.

### Replacement

1. Align the Photo Sensor with the mounting position in the frame metal (provisional), and install the Photo Sensor.
2. Insert the Spring into the Actuator, align it with the mounting position in the frame metal (provisional), and insert the Shaft.
3. Mount the Actuator Cap into the Shaft.
4. Plug the connector (P/J 14) of the (PL) to the DC motor of the Photo Sensor.
5. Align the frame metal (provisional), together with the Sensor Bottle Kit, with the mounting position in the Finisher, and secure them with four screws.
6. Mount the Bottle Assembly-Dust.
7. Close the Cover-Open, Front.
8. Mount the Cover-Rear.
9. Mount the Cover-Top, Rear.
10. Mount the Cover-Jogging.

## Kit Motor Jogging Removal

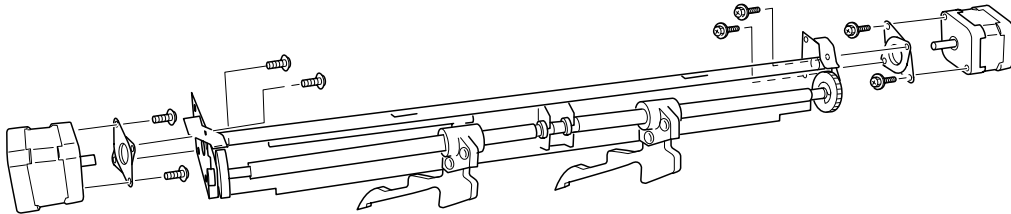
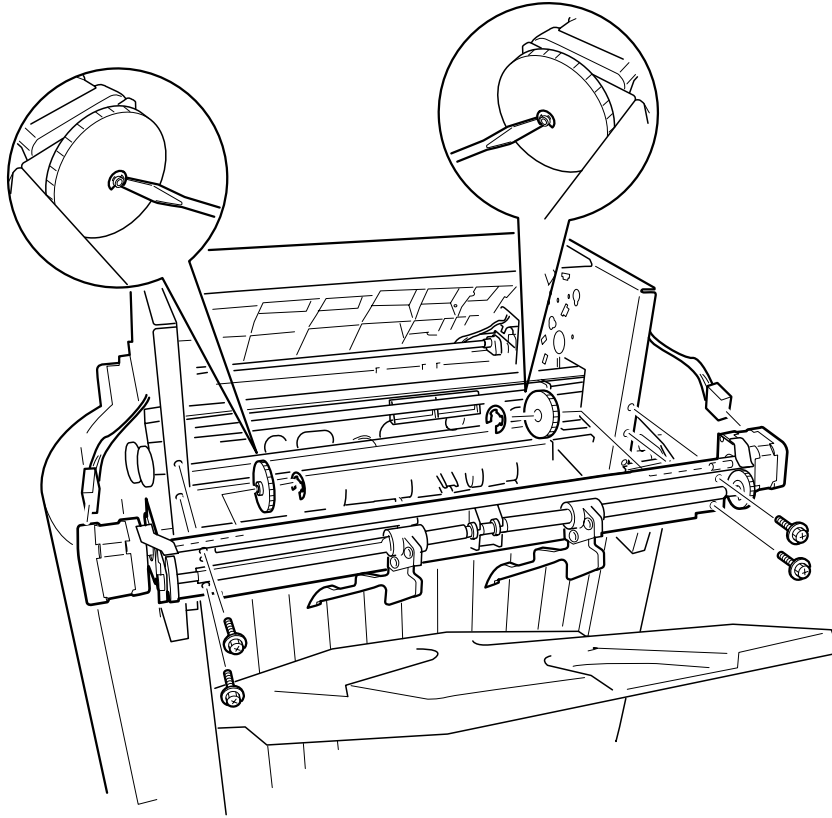

## 4025-Finisher

### Removal

1. Remove the Cover-Jogging.
2. Remove the Cover-Top, Front and Cover-Top, Rear.
3. Remove the Sensor Assembly.
4. Remove the Sensor, Jogger Home Position.
5. Unplug the connector (CN 3) of the Harness Motor from the Stepping Motor (Front).
6. Unplug the connector (CN 4) of the Harness Motor from the Stepping Motor (Rear).
7. Remove four screws that secure to the Finisher from the Jogging Assembly, and remove the Jogging Assembly. (Figure 1)

**Note:** In the following steps, the procedure for removing the Damper and Stepping Motor on the front is the same as for removing the ones on the rear. Apply the same procedure to the rear.

8. Remove the E-ring that secures the Gear (Front) to the shaft of the Stepping Motor (Front), and remove the Gear (Front).
9. Remove two screws that secure the Damper (Front) to the Frame Assembly-Jogger, and remove the Damper (Front) together with the Stepping Motor (Front).
10. Remove two screws that secure the Stepping Motor (Front) to the Damper (Front), and remove the Stepping Motor (Front).

### Replacement

1. Align the Damper (Front) with the mounting position in the Stepping Motor (Front), and secure it with two screws.
2. Align the Damper (Front), together with the Stepping Motor (Front), with the mounting positions in the Frame Assembly-Jogger, and secure them with two screws.
3. Facing the convex toward the motor, insert the Gear (Front) into the shaft of the Stepping Motor (Front), and secure it with an E-ring.
4. Perform the above steps on the rear in the same manner.
5. Align the Kit Motor Jogging with the mounting positions in the Finisher, and secure them with four screws.
6. Plug the connector (CN 4) of the Harness Motor to the Stepping Motor (Rear). (Figure 2)
7. Plug the connector (CN 3) of the Harness Motor to the Stepping Motor (Front).
8. Mount the Sensor, Jogger Home Position.
9. Mount the Sensor Assembly.
10. Mount the Cover-Top, Front and Cover-Top, Rear.
11. Mount the Cover-Jogging.

## Sensor, Jogger Home Position Removal

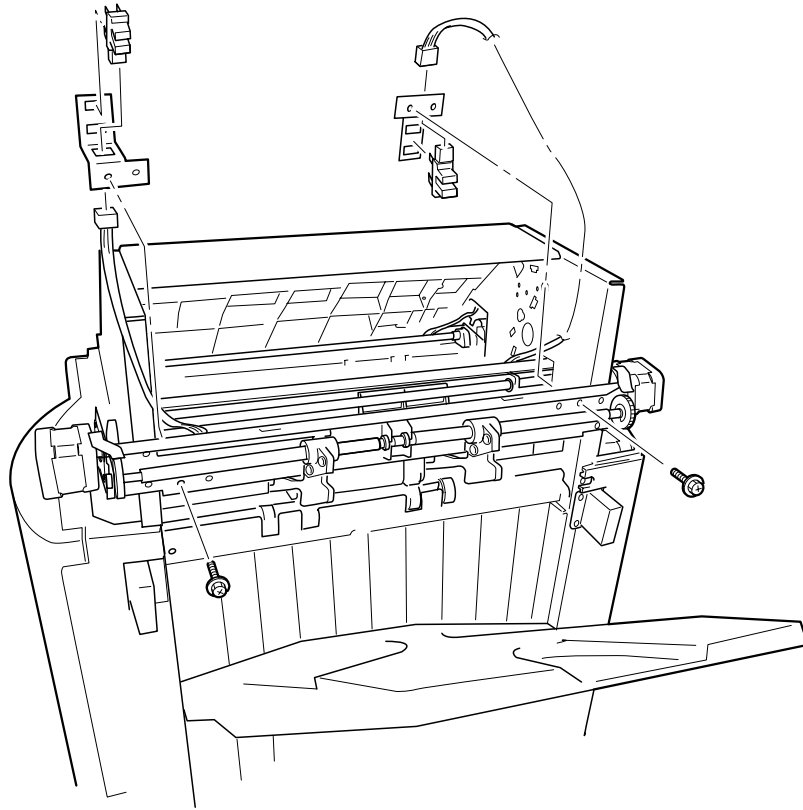



### Removal

1. Remove the Cover-Jogging.
2. Remove the Cover-Top, Front and Cover-Top, Rear.
3. Remove the Sensor Assembly.

**WARNING:** In the following steps, do not detach the Bracket far away because the connector (P/J 8) of the Sensor (Front) is still connected.

4. Remove the screw that secures the Bracket (Front) to the Finisher, and lift up the Bracket (Front) together with the Sensor (Front).
5. Unplug the connector (P/J 8) of the Harness Sensor from the Sensor (Front).
6. Unhook the Sensor (Front) at three places, and remove the Sensor (Front) from the Bracket (Front).
7. Unplug the connector (P/J 9) of the Harness Sensor from the Sensor (Rear).
8. Remove the screw that secures the Bracket (Rear) to the Finisher, and remove the Bracket (Rear) together with the Sensor (Rear).
9. Unhook the Sensor (Rear) at three places, and remove the Sensor (Rear) from the Bracket (Rear).

### Replacement

**Note:** In the following steps, the procedure for mounting the Sensor and Bracket on the front is the same as for mounting the ones on the rear. Apply the same procedure to the rear.

1. Insert the connector of the Sensor (Front) into the hole in the Bracket (Front), align the Sensor (Front) with the mounting position in the Bracket (Front), hook it at three places.
2. Plug the connector (P/J 8) of the Harness Sensor to the Sensor (Front).
3. Align the Bracket (Front), together with the Sensor (Front), with the mounting positions in the Finisher, and secure them with a screw.
4. Mount the Sensor Assembly.
5. Mount the Cover-Top, Front and Cover-Top, Rear.
6. Mount the Cover-Jogging.

## Plate-Jogger Removal

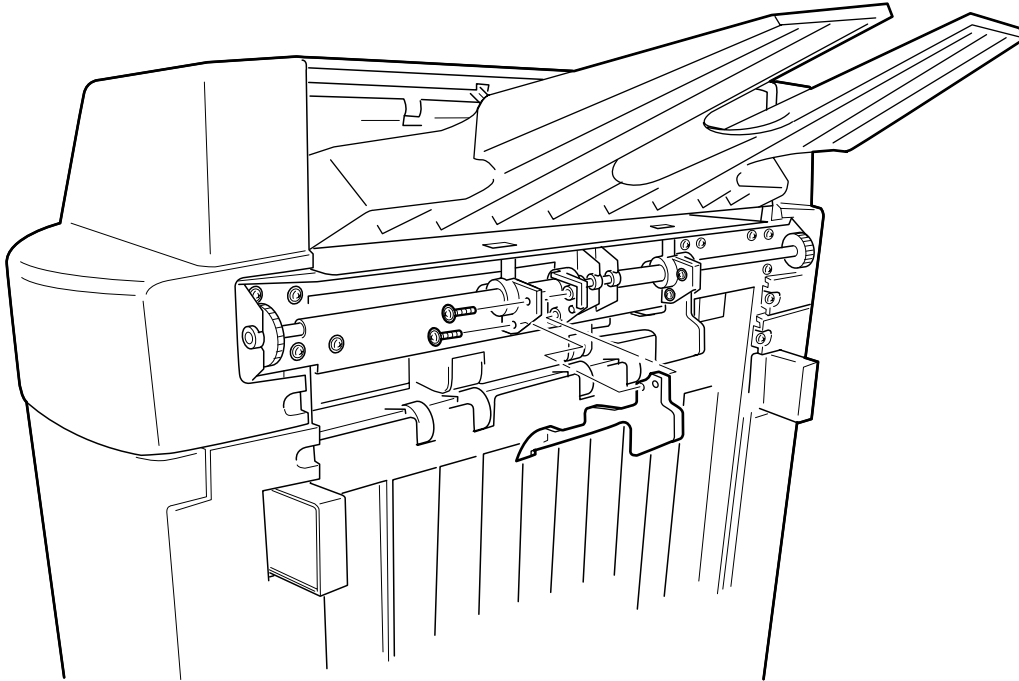

### Removal

1. Remove the Tray-Lower.
2. Remove the Cover-Jogging.
3. Remove the screw that secures the Plate-Jogger (Front) to the Frame Assembly-Jogger, and separate two brackets of the Frame Assembly-Jogger that sandwich the Plate-Jogger (Front), and then remove the Plate-Jogger (Front).
4. For the Plate-Jogger (Rear), perform the above step in the same manner.

### Replacement

1. Sandwich the Plate-Jogger (Front) with two brackets on the front of the Frame Assembly-Jogger so that the boss engages with the hole, and then secure them with one screw.
2. For the Plate-Jogger (Rear), perform the above step in the same manner.
3. Mount the Cover-Jogging.
4. Mount the Tray-Lower.

### Kit Shift Assembly Removal

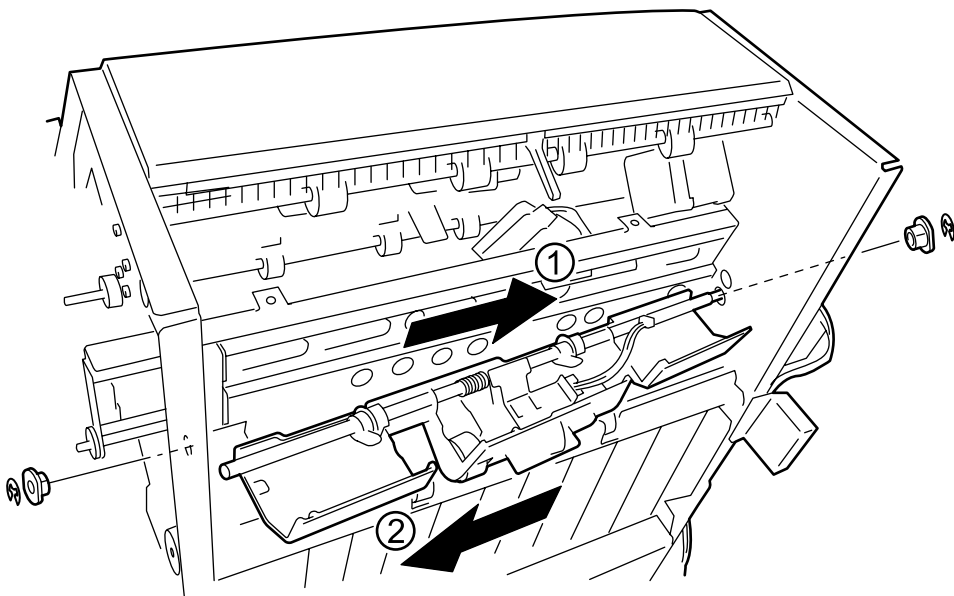
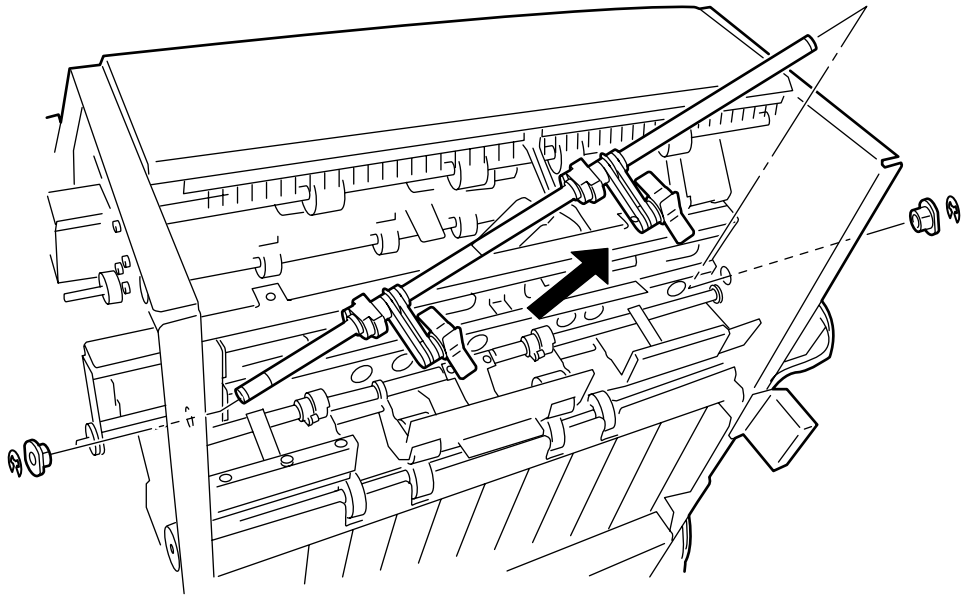

# 4025-Finisher

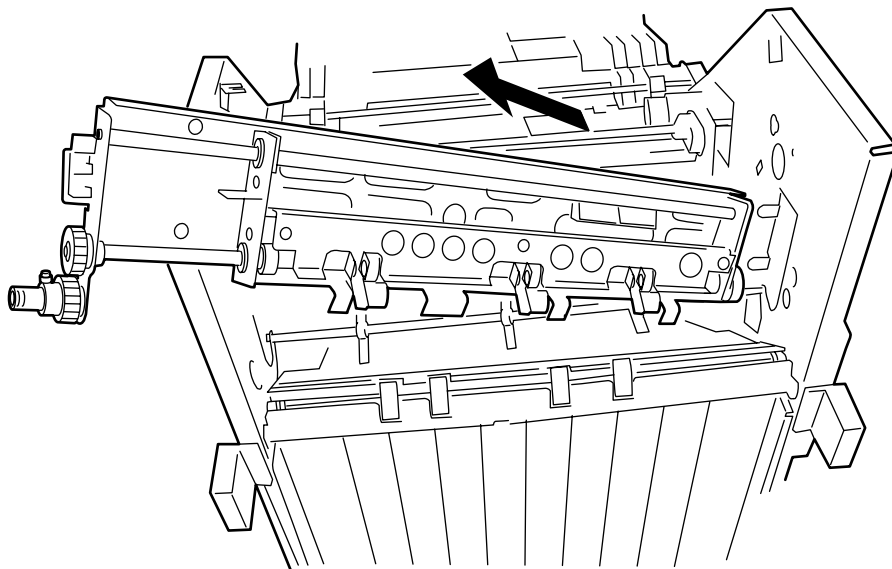
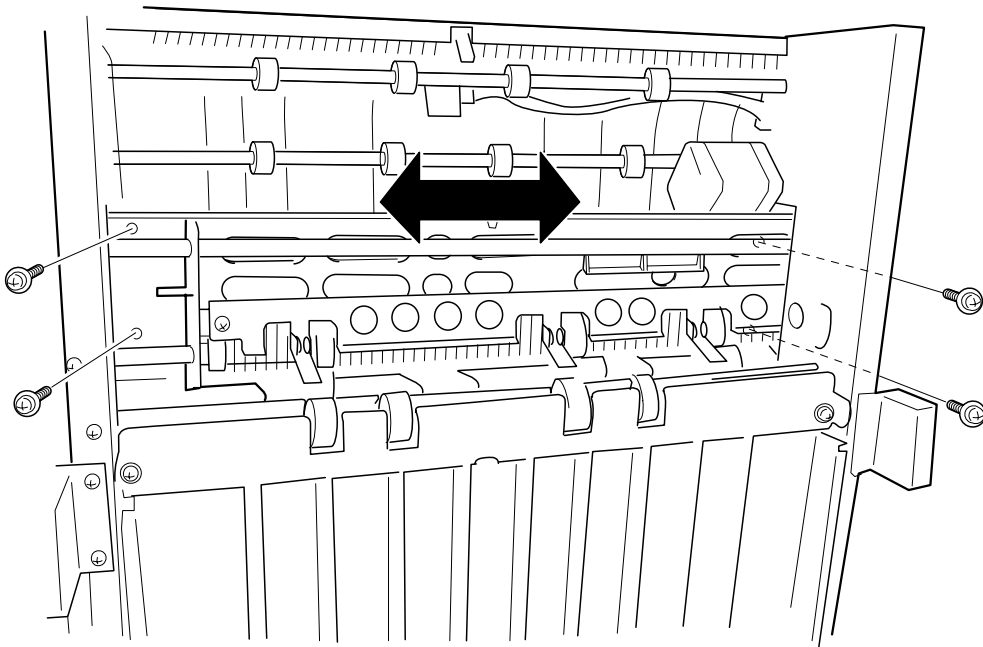

### Removal

1. Remove the Cover-Jogging.
2. Remove the Cover-Top, Front and Cover-Top, Rear.
3. Mount the Sensor Assembly.
4. Remove the Kit Shift Motor.
5. Remove the Kit Motor Jogging.
6. Remove the Kit Shift Assembly.
7. Remove the Cover-Rear.
8. Remove the Cover-Open, Front, Cover-Front and Kit Stud Cover.
9. Remove the Compiler Roll and Roll Shaft.
10. Remove the Motor Assembly-MP4.
11. Remove the Kit Gear Front.
12. Remove the Kit Gear Rear.
13. Remove the front and rear E-rings that secure to the Finisher from the Paddle Shaft Assembly, and remove the front and rear Bearing. (Figure 2)
14. Sliding the Paddle Shaft Assembly toward the front until the rear shaft of the Paddle Shaft Assembly enters the rear frame of the Finisher, pull it off in the rear diagonal upward direction. (Figure 2)
15. Remove two E-rings that secure the front and rear sides of the Shaft, and remove the front and rear Bearing. (Figure 3)
16. Unplug the connector (P/J 5) of the Harness Exit from the Sensor, Exit Path.
17. Unplug the connector (CN 43) of the Harness Motor from the Exit Roll.
18. Sliding the Shaft toward the rear until the front shaft of the Shaft enters the front frame of the Finisher, pull off the Kit Compiler Guide in the front diagonal upward direction.
19. Remove four screws that secure to the Finisher from the Kit Shift Assembly. When removing four screws, slide the L Cover of the Kit Shift Assembly to the front or rear where the screws can be seen.
20. Slide the Kit Shift Assembly toward the rear until the end of the Kit Shift Assembly enters the Finisher, and lifting up the front, remove it in a diagonal upward direction.

## 4025-Finisher

### Replacement

1. Insert the rear of the Kit Shift Assembly into the mounting hole in the frame on the rear of the Finisher.
2. Insert the front of the Kit Shift Assembly into the mounting hole in the frame on the front of the Finisher, and align it with the mounting position.
3. Secure the Frame Assembly-Roll, Shift to the Finisher with four screws. When securing with four screws, slide the sheet metal of the Kit Shift Assembly to the front or rear where the screws can be seen.
4. Insert the shaft on the rear of the Kit Compiler Guide into the hole in the frame on the rear of the Finisher, and insert the shaft on the front of the Shaft into the hole in the frame on the front of the Finisher.
5. Plug the connector (P/J 5) of the Harness Exit to the Sensor, Exit Path.
6. Plug the connector (CN 43) of the Harness Motor to the Exit Roll.
7. Insert two Bearing into the front and rear sides of the Shaft, align them with the mounting positions, and secure them with two E-rings. (Figure 3)
8. Insert the shaft on the front of the Paddle Shaft Assembly into the hole in the frame on the front of the Finisher, and insert the shaft on the rear of the Paddle Shaft Assembly into the hole in the frame on the rear of the Finisher. (Figure 2)
9. Insert the Bearing on the front and rear into the front and rear of the Paddle Shaft Assembly, align them with the mounting positions, and secure them with two E-rings. (Figure 2)
10. Mount the Kit Gear Rear.
11. Mount the Kit Gear Front.
12. Mount the Motor Assembly-MP4.
13. Mount the Compiler Roll and Roll Shaft.
14. Mount the Cover-Open, Front, Cover-Front and Kit Stud Cover.
15. Mount the Cover-Rear.
16. Mount the Kit Shift Assembly.
17. Mount the Kit Motor Jogging.
18. Mount the Kit Shift Motor.
19. Mount the Sensor Assembly.
20. Mount the Cover-Top, Front and Cover-Top, Rear.
21. Mount the Cover-Jogging.

## Knob, Shift Unit Removal

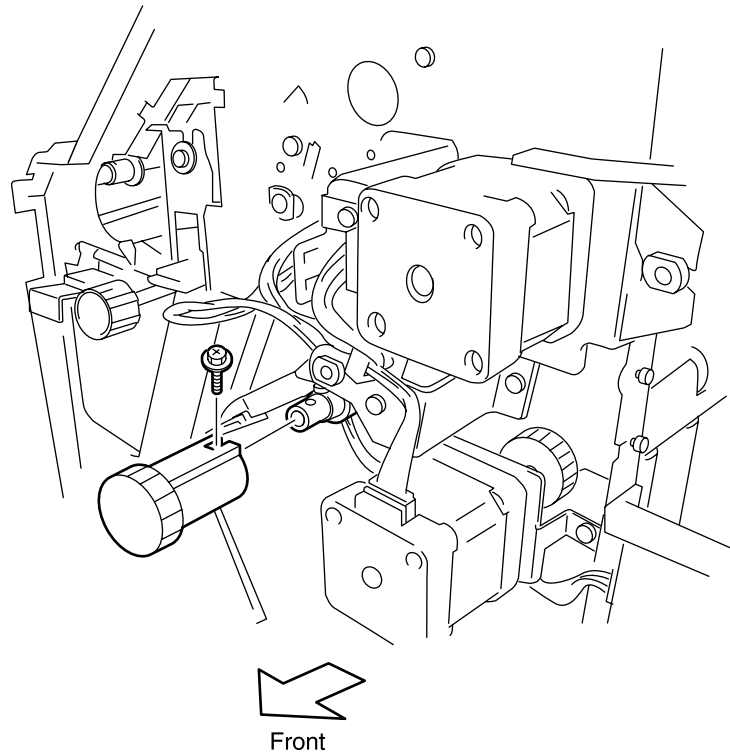

### Removal

1. Remove the Cover-Jogging.
2. Remove the Cover-Top, Rear.
3. Remove the Cover-Open, Front, Cover-Front and Kit Stud Cover.
4. Remove the screw that secures to the shaft of the Frame Assembly-Roll, Shift from the Knob, Shift Unit, and pull off the Knob, Shift Unit.

### Replacement

1. Insert the Knob, Shift Unit into the shaft of the Frame Assembly-Roll, Shift, and secure it with a screw.
2. Mount the Cover-Open, Front, Cover-Front and Kit Stud Cover.
3. Mount the Cover-Top, Rear.
4. Mount the Cover-Jogging.

## Kit Shift Motor Removal

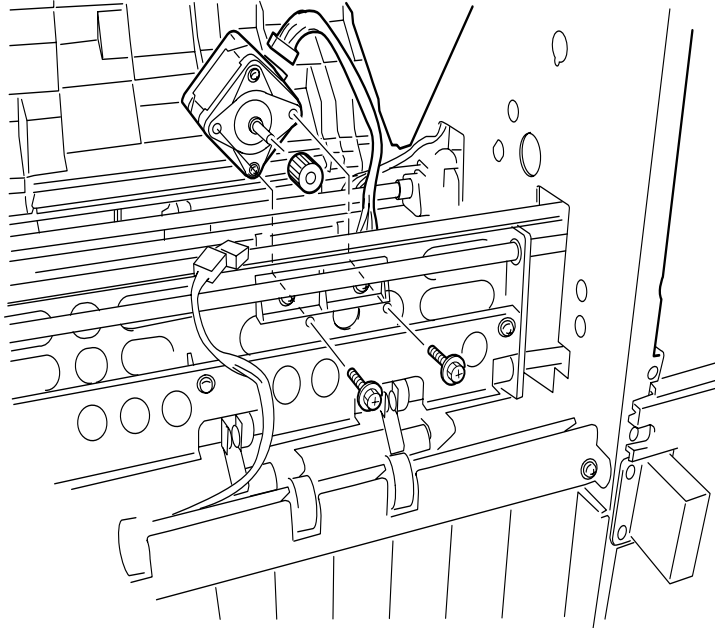

### Removal

1. Remove the Cover-Jogging.
2. Remove the Cover-Top, Front and Cover-Top, Rear.
3. Remove the Sensor Assembly.
4. Remove the Kit Shift Motor.
5. Remove the Kit Motor Jogging.
6. Unplug the connector (CN 5) of the Harness Motor from the Motor-MP5.
7. Remove two screws that secure to the Damper from the Finisher, and remove the Damper together with the Gear and Motor-MP5.
8. Remove the E-ring that secures the Gear to the shaft of the Motor-MP5, and remove the Gear.
9. Remove two screws that secure the Motor-MP5 to the Damper, and remove the Motor-MP5.

### Replacement

1. Align the Motor-MP5 with the mounting position in the Damper, and secure it with two screws.
2. Insert the Gear into the shaft of the Motor-MP5, and secure it with an E-ring.
3. Align the Damper, together with the Gear and Motor-MP5, with the mounting positions in the Finisher, and secure them with two screws.
4. Plug the connector (CN 5) of the Harness Motor to the Motor-MP5.
5. Mount the Kit Motor Jogging and the Kit Shift Motor.
6. Mount the Sensor Assembly.
7. Mount the Cover-Top, Front and Cover-Top, Rear.
8. Mount the Cover-Jogging.



## Motor Assembly-MP2 Removal

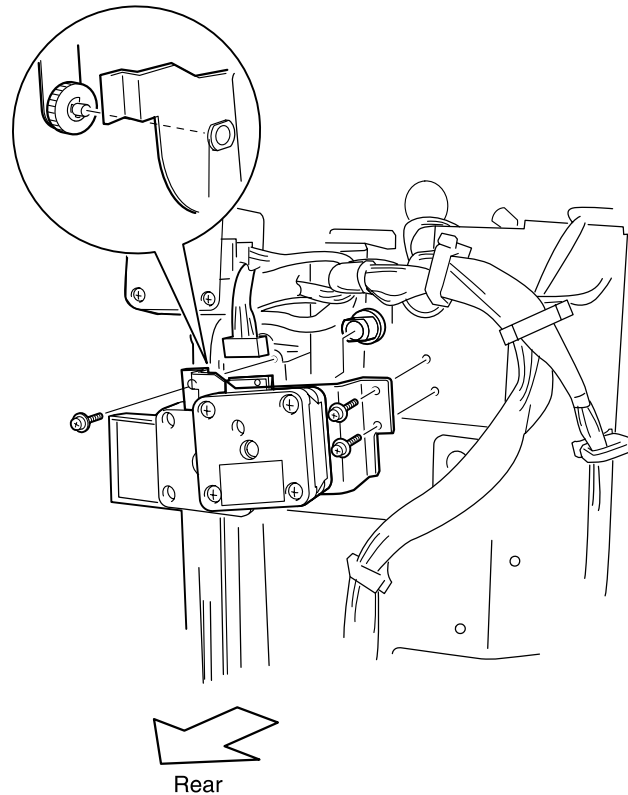

### Removal

1. Remove the Cover-Jogging.
2. Remove the Cover-Top, Rear.
3. Remove the Cover-Rear.
4. Unclamp the harness of the Clamp.
5. Unplug the connector (CN 2) of the Harness Motor from the Motor Assembly-MP2.
6. Remove the screw that secures to the Motor Assembly-MP4 from the Motor Assembly-MP2.

**WARNING:** In the following steps, the Bearing is not secured and easily removed. Take care not to drop or damage it.

7. Remove two screws that secure to the Finisher from the Motor Assembly-MP2, and remove the Motor Assembly-MP2 together with the Bearing.

## **Replacement**

- 1.** Insert the Bearing into the Motor Assembly-MP2.
- 2.** Align the Motor Assembly-MP2, together with the Bearing, with the mounting position in the Finisher so that the hole in the Bearing enters the shaft of the Frame Assembly-Roll, Shift, and secure them with two screws.
- 3.** Secure the Motor Assembly-MP2 to the Motor Assembly-MP4 with a screw.
- 4.** Plug the connector (CN 2) of the Harness Motor to the Motor Assembly-MP2.
- 5.** Clamp the harness with the Clamp.
- 6.** Mount the Cover-Rear.
- 7.** Mount the Cover-Top, Rear.
- 8.** Mount the Cover-Jogging.

## Sensor, Exit Path Removal

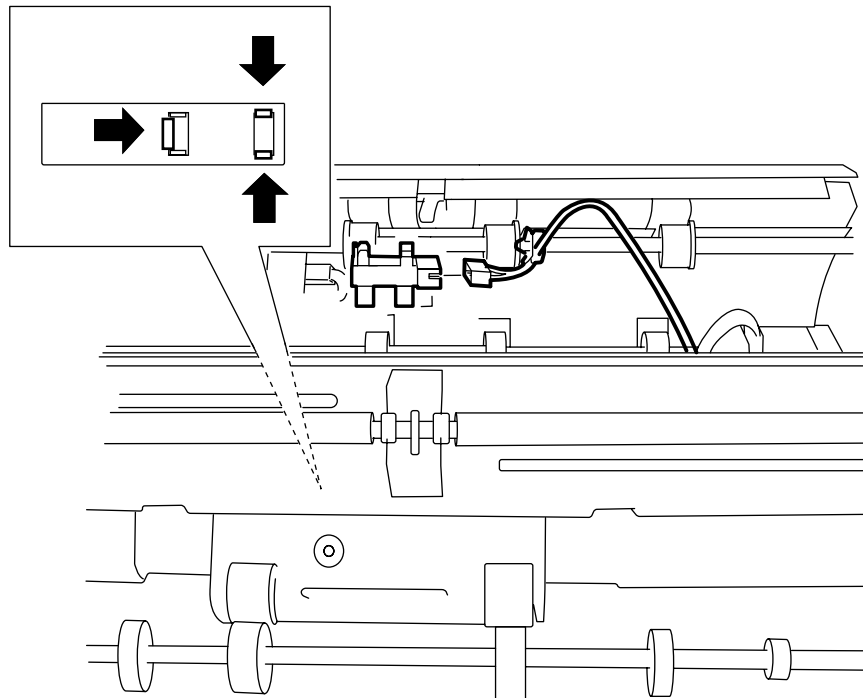

### Removal

1. Remove the Cover-Jogging.
2. Remove the Cover-Top, Front and Cover-Top, Rear.
3. Remove the Sensor Assembly.
4. Unplug the connector (P/J 5) of the Harness Exit from the Sensor.
5. Unhook the Sensor at three places, and remove the Sensor.

### Replacement

1. Align the Sensor with the mounting position in the Compiler Guide to secure it.
2. Plug the connector (P/J 5) of the Harness Exit to the Sensor.
3. Mount the Sensor Assembly.
4. Mount the Cover-Top, Front and Cover-Top, Rear.
5. Mount the Cover-Jogging.

## Compiler Roll and Roll Shaft Removal

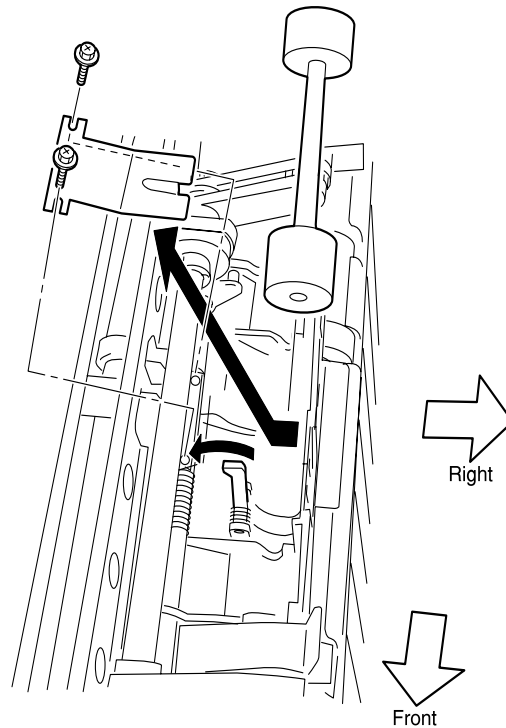

### Removal

1. Remove the Cover-Jogging.
2. Remove the Cover-Top, Front and Cover-Top, Rear.
3. Remove the Sensor Assembly.
4. Remove the Sensor, Jogger Home Position.
5. Remove the Kit Motor Jogging.
6. Remove two screws that secure to the Shaft from the Support, and remove the Support.
7. Avoiding the Actuator with your finger, release the Roll Shaft from two bearings of Compiler Guide and remove the Roll Shaft together with two Compiler Rolls.

### Replacement

1. Avoiding the Actuator with your finger, mount the Roll Shaft together with two Compiler Roll on two bearings of the Compiler Guide.
2. Insert two bosses of Support into the holes in the Compiler Guide, and then align the Shaft to its mounting position so that it pushes the hook of the Spring, then secure with two screws.
3. Mount the Kit Motor Jogging.
4. Mount the Sensor, Jogger Home Position.
5. Mount the Sensor Assembly.
6. Mount the Cover-Top, Front and Cover-Top, Rear.
7. Mount the Cover-Jogging.

## Sensor, Exit Roller Open/Close Home Position Removal

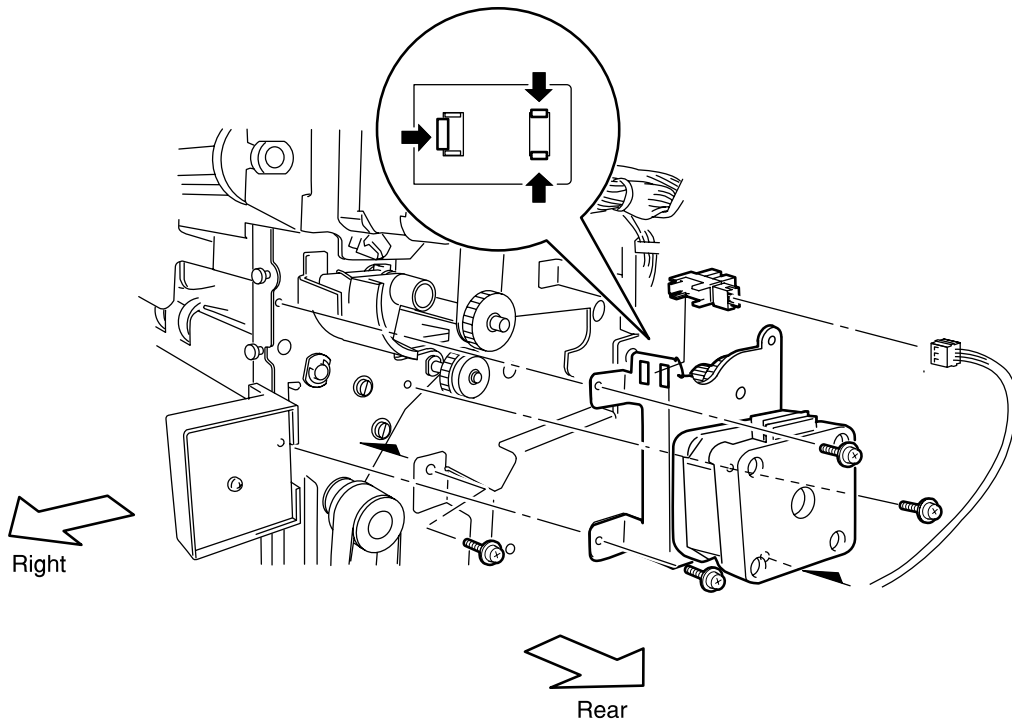

### Removal

1. Remove the Cover-Jogging and the Cover-Top, Rear.
2. Remove the Motor Assembly-MP2.
3. Unplug the connector (CN 4) of the Harness Motor from the Motor Assembly-MP4.
4. Unplug the connector (P/J 6) of the Harness Sensor from the Sensor, Exit Roller Open/Close Home Position.
5. Remove the screws that secure to the Finisher from the Motor Assembly-MP4, and remove the Motor Assembly-MP4.
6. Unhook the Sensor, Exit Roller Open/Close Home Position at three places, and remove the Sensor, Exit Roller Open/Close Home Position from the Motor Assembly MP4.

### Replacement

1. Align the Sensor, Exit Roller Open/Close Home Position with the mounting position in the Motor Assembly-MP4 to secure it.
2. Align the Motor Assembly-MP4, together with the Sensor, Exit Roller Open/Close Home Position, with the mounting position in the Finisher, and secure them with the screws.
3. Plug the connector (P/J 6) of the Harness Sensor to the Sensor, Exit Roller Open/Close Home Position.
4. Plug the connector (CN 4) of the Harness Motor to the Motor Assembly-MP4.
5. Mount the Motor Assembly-MP2.
6. Mount the Cover-Top, Rear and the Cover-Jogging.

## Exit Roll Sensor Removal

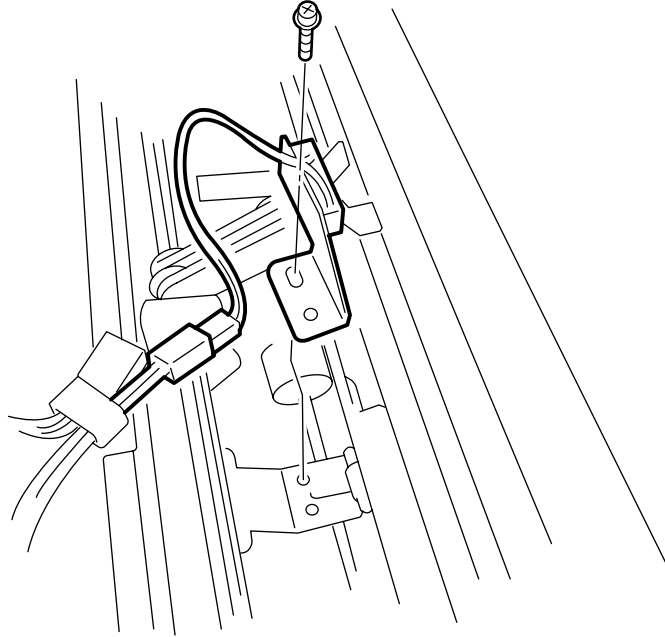

### Removal

1. Remove the Cover-Top, Front and Cover-Top, Rear.
2. Remove the Sensor Assembly.
3. Unplug the connector (CN 43) of the Harness Motor from the Exit Roll.
4. Remove the screw that secures to the Exit Roll, and remove the Exit Roll.

### Replacement

1. Align the Exit Roll with the mounting position in the Compiler Guide to secure it.
2. Plug the connector (CN 43) of the Harness Motor to the Exit Roll.
3. Mount the Sensor Assembly.
4. Mount the Cover-Top, Front and Cover-Top, Rear.

## Kit Gear Front Removal

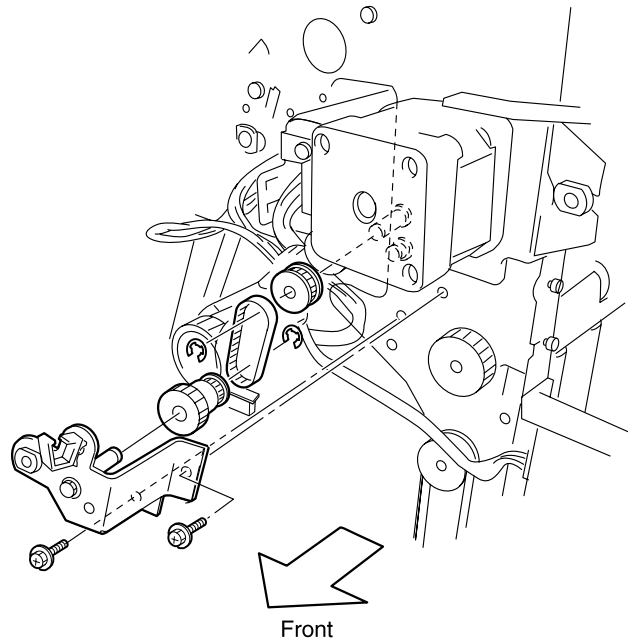

### Removal

1. Remove the Cover-Jogging.
2. Remove the Cover-Top, Front.
3. Remove the Cover-Open, Front, Cover-Front and Kit Stud Cover.
4. Remove the Motor Assembly-MP4.
5. Unclamp the harness of the Clamp.
6. Remove the E-ring that secures the Pulley to the shaft of the Paddle Shaft Assembly.
7. Remove two screws that secure to the Finisher from the Bracket, and pull off the Bracket together with the Bearing, Clamp and Kit Gear Front toward the front.
8. Remove the E-ring that secures the Pulley Gear to the Bracket, and remove the Pulley Gear.

### Replacement

1. Insert the Pulley Gear into the shaft of the Bracket, and secure it with an E-ring.
2. With the Pulley and Pulley Gear meshed with the Belt, insert the Pulley into the shaft of the Paddle Shaft Assembly, and align the Bracket with the mounting position in the Finisher, and then secure it with two screws.
3. Secure the Pulley to the shaft of the Paddle Shaft Assembly with an E-ring.
4. Clamp the harness with the Clamp.
5. Mount the Motor Assembly-MP4.
6. Mount the Cover-Open, Front, Cover-Front and Kit Stud Cover.
7. Mount the Cover-Top, Front.
8. Mount the Cover-Jogging.

## Motor Removal

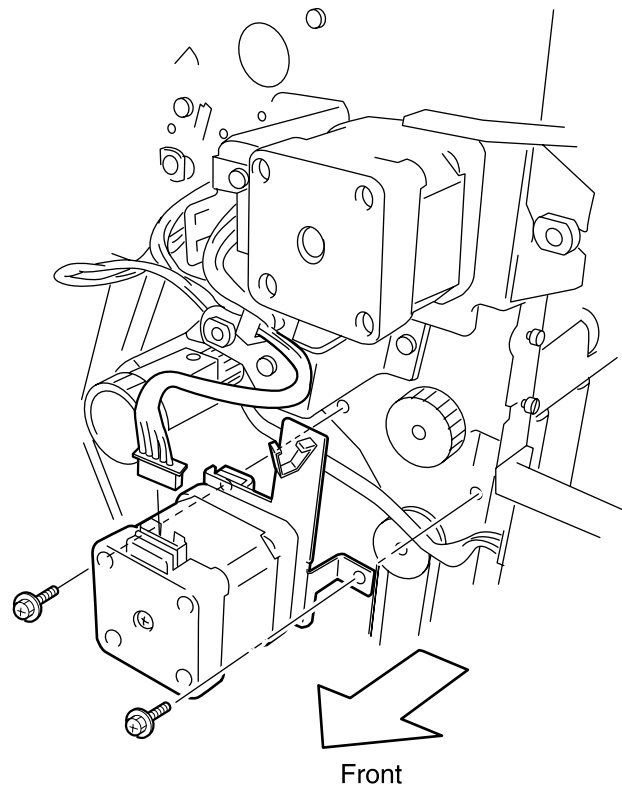

## Removal

1. Remove the Cover-Top, Front.
2. Remove the Cover-Open, Front, Cover-Front and Kit Stud Cover.
3. Unplug the connector (CN 3) of the Harness Motor from the Motor.
4. Remove the screws that secure to the Finisher from the Motor, and remove the Motor.

## Replacement

1. Align the Motor with the mounting position, and secure it with the screws.
2. Plug the connector (CN 3) of the Harness Motor to the Motor.
3. Mount the Cover-Open, Front, Cover-Front and Kit Stud Cover.
4. Mount the Cover-Top, Front.



### Kit Gear Rear Removal

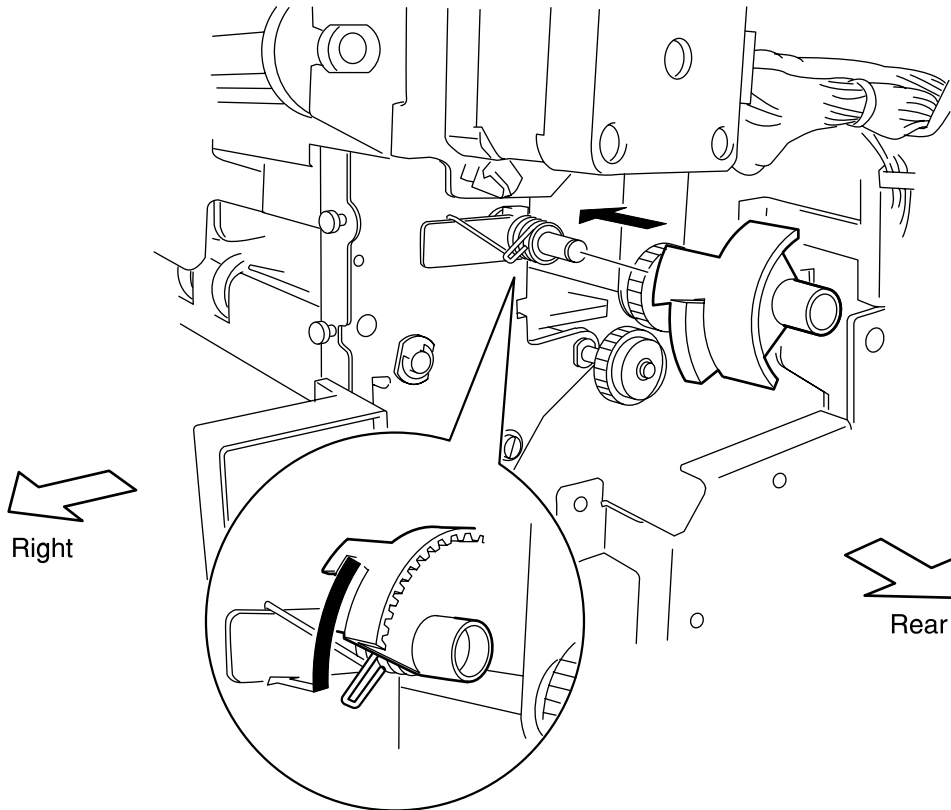
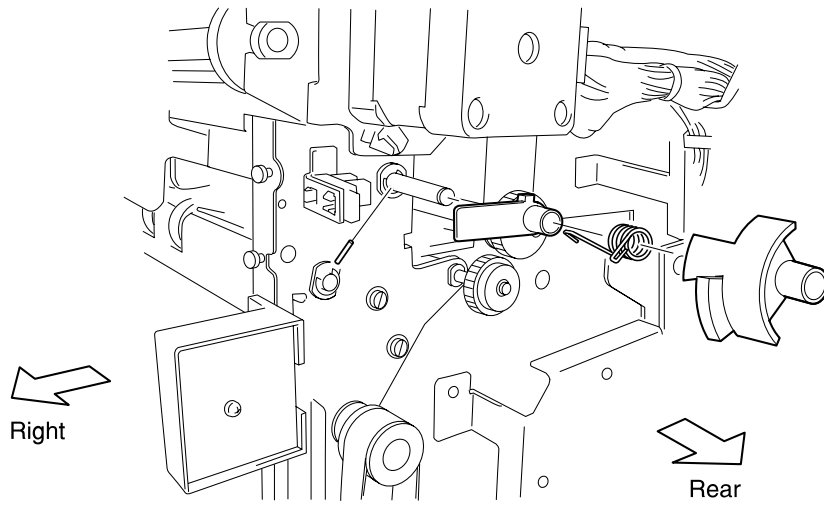

### Removal

1. Remove the Cover-Jogging.
2. Remove the Cover-Top, Front.
3. Remove the Compiler Roll and Roll Shaft.

**Note:** In the following steps, removing the Lever, Spring and Sector Gear allows the Pin inserted into the hole in the Shaft to be unsecured. Take care not to drop or lose it.

4. Remove the E-ring that secures the Lever, Spring and Sector Gear to the Shaft, and pull off the Lever, Spring and Sector Gear.
5. Remove the Pin from the Shaft.

### Replacement

1. Insert the Pin into the hole in the Shaft, and then the Lever into the Shaft.
2. Insert the longer hook of the Spring into the Shaft, and engage the long hook of the Spring with the upper of the Lever.
3. Insert the Sector Gear in the midway of the Shaft, and engage the shorter hook of the Spring with the lower of the Shaft. (Figure 2)
4. Turn the Sector Gear counterclockwise to hook it to the lower of the Lever. (Figure 2)
5. Secure the Lever, Spring and Sector Gear to the Shaft with an E-ring.
6. Mount the Compiler Roll and Roll Shaft.
7. Mount the Cover-Top, Front.
8. Mount the Cover-Jogging.

## Motor Assembly-MP4 Removal

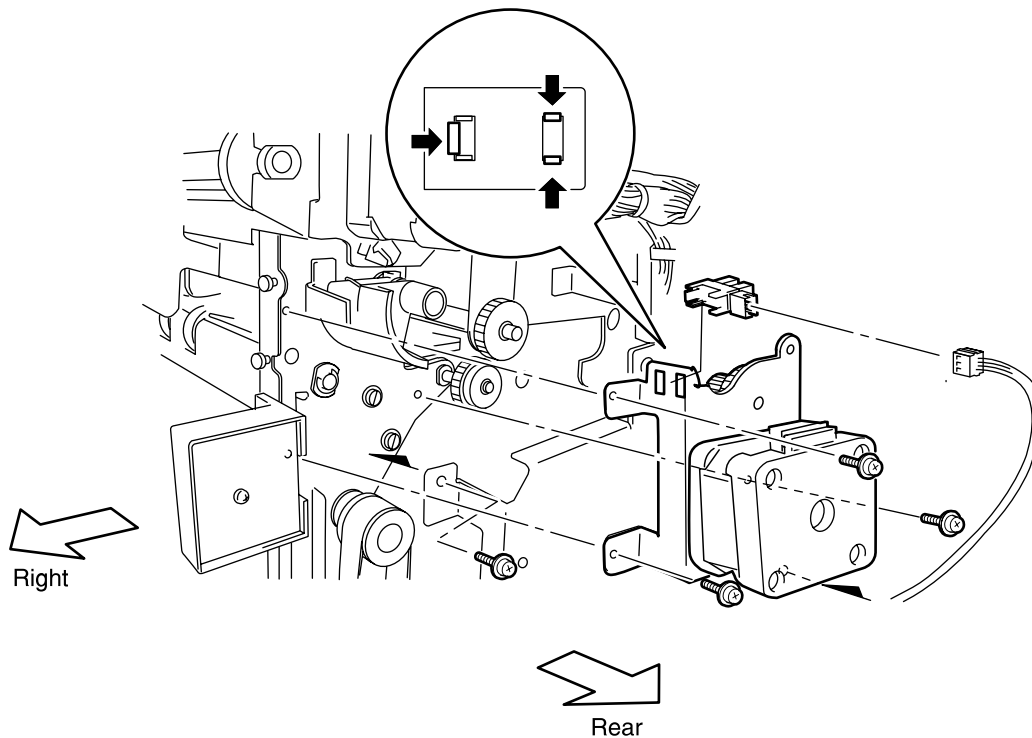

### Removal

1. Remove the Cover-Jogging.
2. Remove the Cover-Top, Front.
3. Unplug the connector (CN 4) of the Harness Motor from the Motor Assembly-MP4.
4. Remove the screws that secure to the Finisher from the Motor Assembly-MP4, and remove the Motor Assembly-MP4 with the Sensor, Exit Roller Open/Close Home Position.
5. Unhook the Sensor, Exit Roller Open/Close Home Position at three places, and remove the Sensor, Exit Roller Open/Close Home Position from the Motor Assembly-MP4.

### Replacement

1. Align the Sensor, Exit Roller Open/Close Home Position with the mounting positions in the Motor Assembly-MP4, and secure it.
2. Align the Motor Assembly-MP4 with the mounting position in the Finisher, and secure it with the screws.
3. Plug the connector (CN 4) of the Harness Motor to the Motor Assembly-MP4.
4. Mount the Cover-Top, Front.
5. Mount the Cover-Jogging.

## Staple Stage Assembly, Stack Roll Shaft, No Paper Sensor Stapler Removal

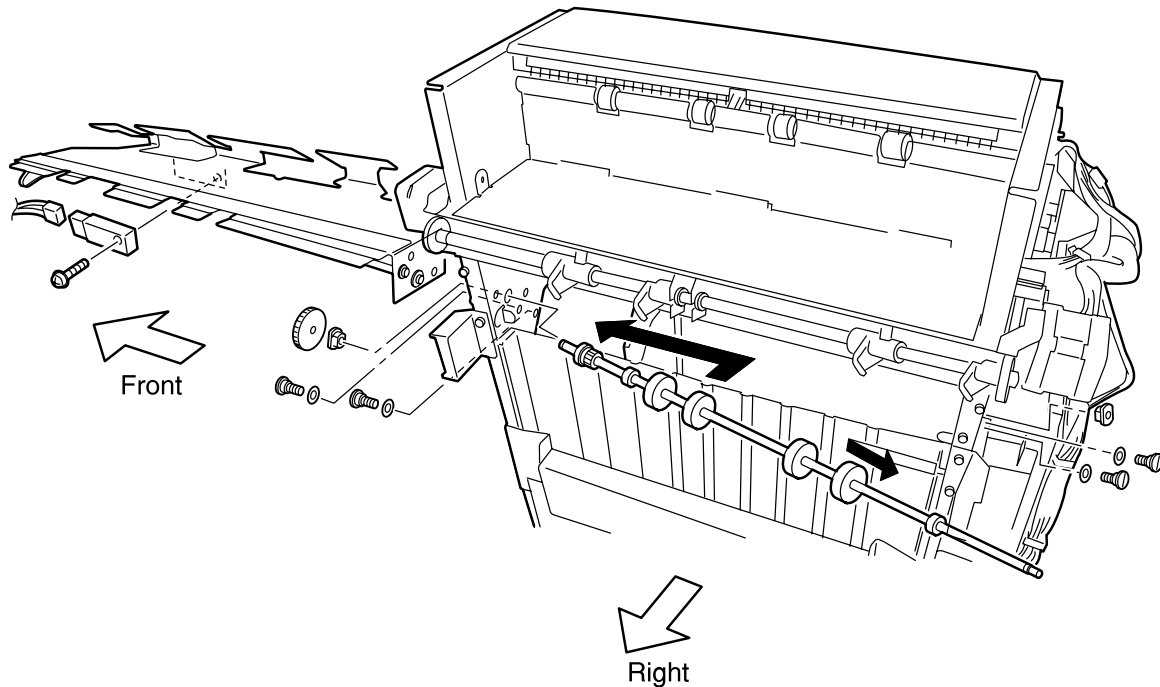

### Removal

1. Remove the Cover-Jogging.
  2. Remove the Cover-Top, Front and Cover-Top, Rear.
  3. Remove the Cover-Open, Front, Cover-Front and Kit Stud Cover.
  4. Remove the Cover-Rear.
  5. Remove the Kit Motor Jogging.
  6. Remove the Motor.
  7. Remove the Motor Assembly-MP2.
  8. Remove the Compiler Roll and Roll Shaft.
  9. Remove the Cartridge.
  10. Remove the Bottle Assembly-Dust.
  11. Remove the Stapler Assembly.
  12. Remove the Right Cover.
  13. Remove the E-ring that secure the Bearing and Gear to the front of the Stack Roll Shaft, and remove the Bearing and Gear.
  14. Remove the E-ring that secures the Bearing to the rear of the Stack Roll Shaft, and remove the Bearing.
  15. Remove the Shoulder Screws on the front that secure the Staple Stage Assembly, together with Spacer, to the Finisher, and remove the Spacers.
- WARNING:** In the following steps, do not detach the Bracket far away because the connector (P/J 13) of the No Paper Sensor Stapler is still connected.
16. Remove the Shoulder Screws on the rear that secure the Staple Stage Assembly to the Finisher.

## 4025-Finisher

17. Release the belt of the Staple Stage Assembly from the gear of the Stack Roll Shaft, and remove the Stack Roll Shaft from the Finisher
18. Disconnect the connector (P/J 13) connector of the No Paper Sensor Stapler attached to the Staple Stage Assembly.
19. Remove the Staple Stage Assembly together with the No Paper Sensor Stapler from the cavity on the front of the Finisher.
20. Remove the screw that secures to the Staple Stage Assembly from the No Paper Align the No Paper Sensor Stapler with the mounting position in the Staple Stage Assembly, and secure it with a screw.

### Replacement

1. Insert the Staple Stage Assembly together with the No Paper Sensor Stapler into the cavity on the front of the Finisher, insert the gear of the Stack Roll Shaft from the right so that it meshes with the belt of the Staple Stage Assembly, and insert the front of the Stack Roll Shaft into the mounting hole on the front of the Finisher.
2. Connect the connector (P/J 13) of the No Paper Sensor Stapler.
3. Insert the rear of the Stack Roll Shaft into the mounting hole on the rear of the Finisher.
4. Insert the Bearing into the front and rear of the Stack Roll Shaft, and align it with the mounting position.
5. Insert the Gear into the front of the Stack Roll Shaft, and secure the front and rear of the Stack Roll Shaft with an E-ring.
6. Check that the gear of the Stack Roll Shaft meshes with the belt of the Staple Stage Assembly, and secure the front of the Staple Stage Assembly, together with two Spacers, with two Shoulder Screws.
7. Secure the rear of the Staple Stage Assembly with two Shoulder Screws.
8. Mount the Right Cover.
9. Mount the Stapler Assembly.
10. Mount the Bottle Assembly-Dust.
11. Mount the Cartridge.
12. Mount the Compiler Roll and Roll Shaft.
13. Mount the Motor Assembly-MP2.
14. Mount the Motor.
15. Mount the Kit Motor Jogging.
16. Mount the Cover-Rear.
17. Mount the Cover-Open, Front, Cover-Front and Kit Stud Cover.
18. Mount the Cover-Top, Front and Cover-Top, Rear.
19. Mount the Cover-Jogging.

## Stack Arm Assembly, No Paper Sensor Tray Lower Removal

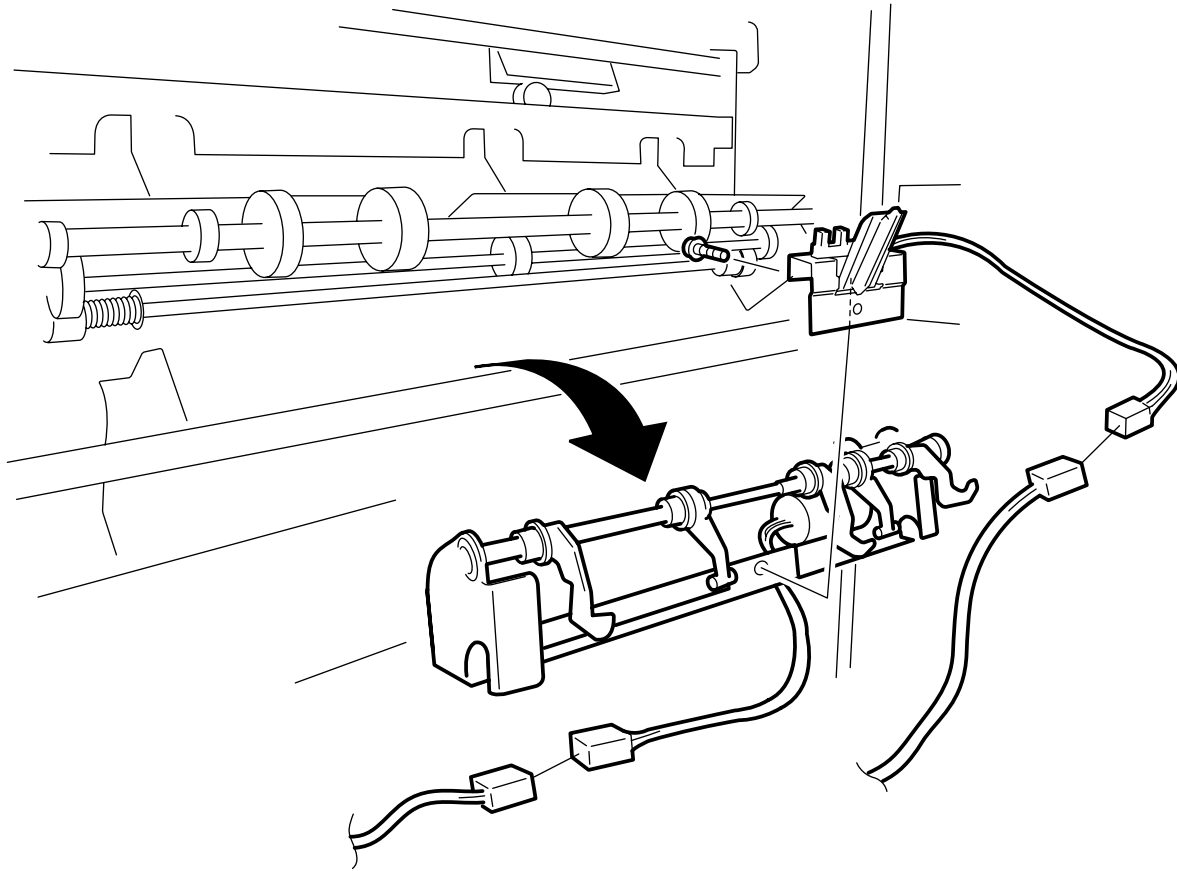

### Removal

1. Remove the Cover-Jogging.
2. Remove the Tray-Lower.
3. Remove the Cover-Top, Front and Cover-Top, Rear.
4. Remove the Cover-Rear.
5. Remove the Cover-Open, Front, Cover-Front and Kit Stud Cover.
6. Remove the Right Cover.
7. Unplug the connector (CN 41) of the Harness Motor from the Stack Arm Assembly.
8. Unplug the connector (P/J 14) of the (PL) from the No Paper Sensor Tray Lower.
9. Remove the Stack Arm Assembly and No Paper Sensor Tray Lower from the Finisher.
10. Remove screw that secure to the Stack Arm Assembly from the No Paper Sensor Tray Lower, and Remove the No Paper Sensor Tray Lower.

## 4025-Finisher

### Replacement

1. Secure the No Paper Sensor Tray Lower to the Stack Arm Assembly with screw.
2. Align the Stack Arm Assembly and No Paper Sensor Tray Lower with the mounting position in the Finisher.
3. Plug the connector (P/J 14) of the (PL) to the No Paper Sensor Tray Lower.
4. Plug the connector (CN 41) of the Harness Motor to the Stack Arm Assembly.
5. Mount the Right Cover.
6. Mount the Cover-Open, Front, Cover-Front and Kit Stud Cover.
7. Mount the Cover-Rear.
8. Mount the Cover-Top, Front and Cover-Top, Rear.
9. Mount the Tray-Lower.
10. Mount the Cover-Jogging.

## Stapler I Assembly Removal

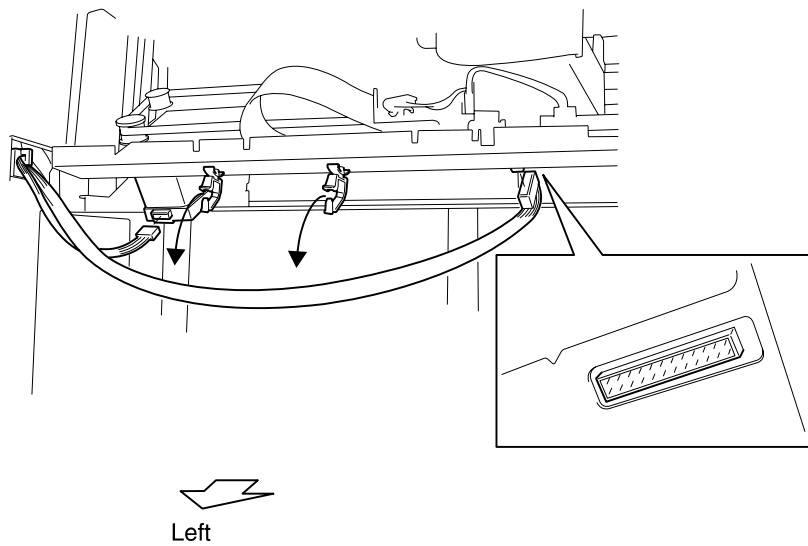
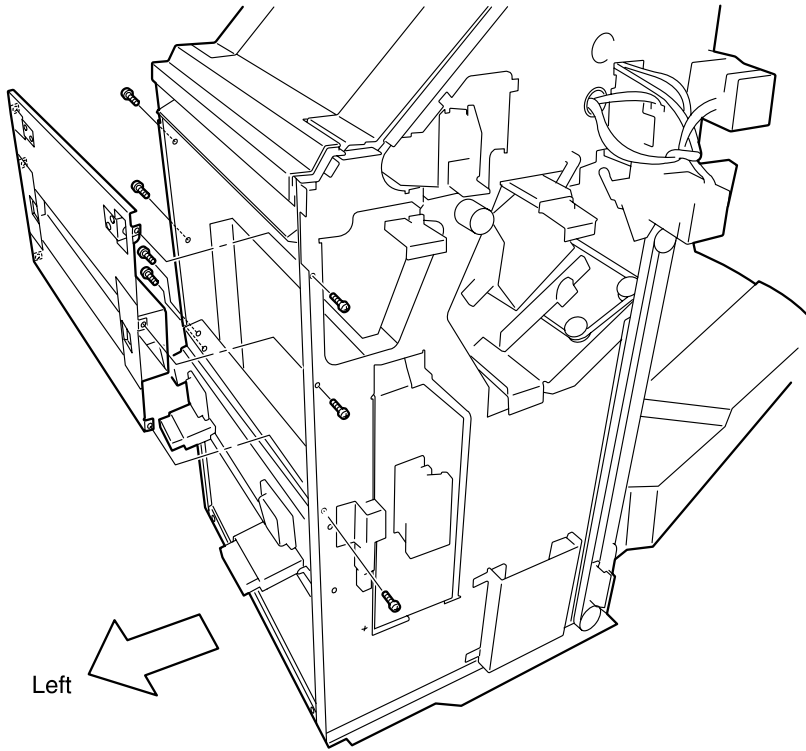



# 4025-Finisher

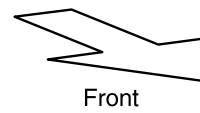
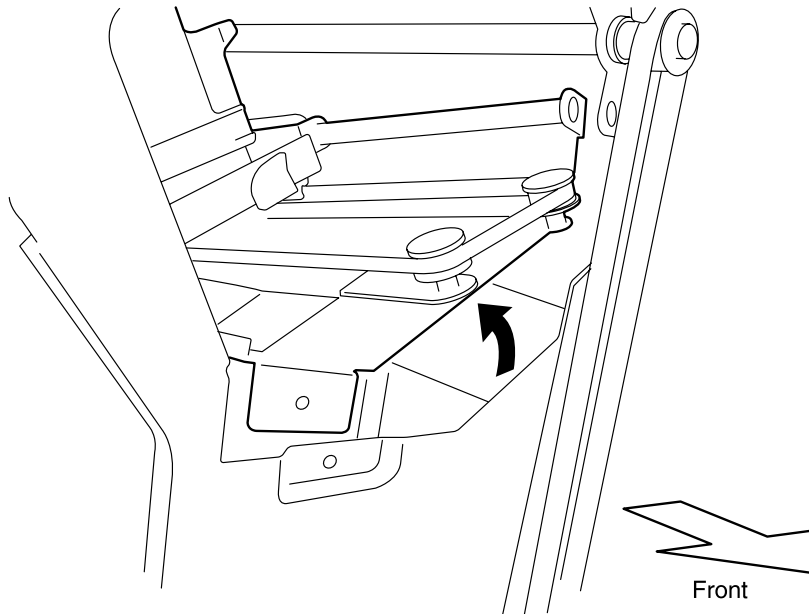
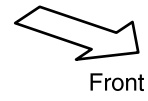
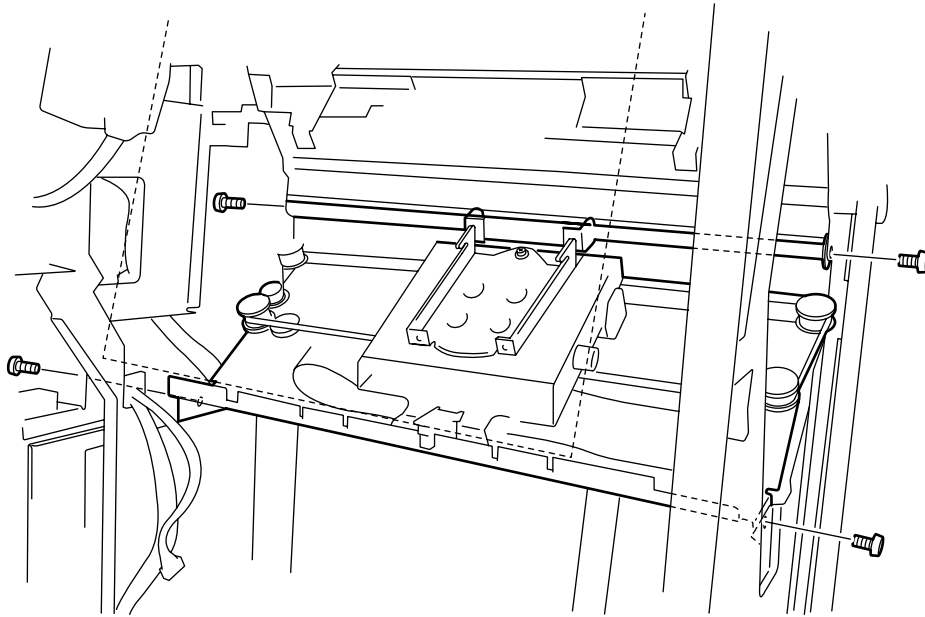

# 4025-Finisher

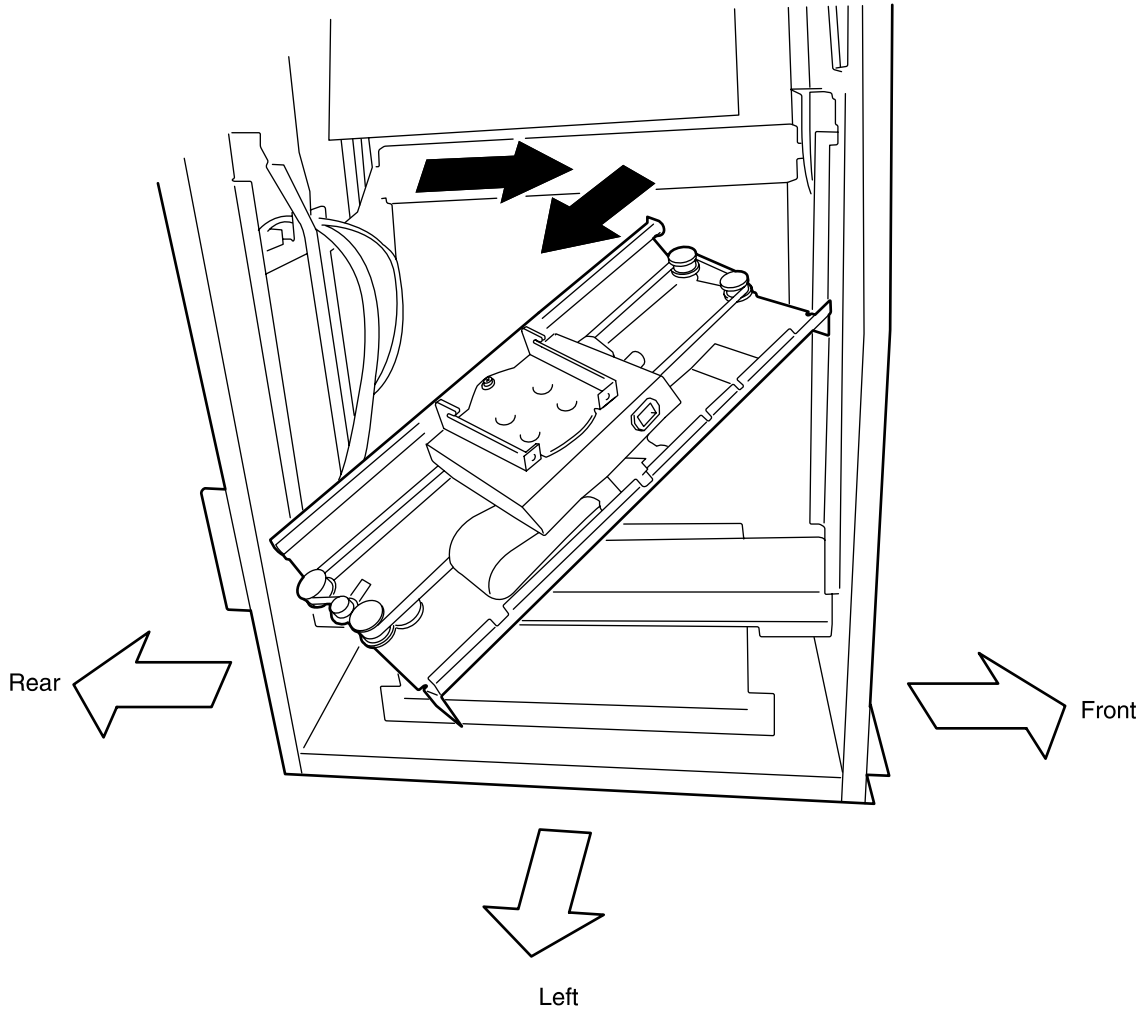

### Removal

1. Remove the Cartridge.
  2. Remove the Bottle Assembly-Dust.
  3. Remove the Cover-Jogging.
  4. Remove the Cover-Top, Front and Cover-Top, Rear.
  5. Remove the Cover-Rear.
  6. Remove the Cover-Open, Front, Cover-Front and Kit Stud Cover.
  7. Remove the Stapler Assembly.
  8. Remove the Inner Cover.
  9. Remove six screws that secure the Cover Upper Left Assembly to the frame of the Finisher, and remove the Cover Upper Left Assembly. (Figure 1)
  10. Remove the Latch Assembly and Switch Docking.
  11. Unplug the connector (CN 8) of the Harness Motor from the Motor Assembly-MP8. (Figure 2)
  12. Unplug the connector (P/J 1D) of the Harness Middle Stapler from the Cable-Flat. (Figure 2)
  13. Unclamp the harness at two places on the rear of the larger frame of the stapler. (Figure 2)
  14. Remove two Screws on the lower side of the Stapler Assembly, which secure to the Finisher frame, from the Stapler Assembly. (Figure 3)
- WARNING:** In the following steps, the Stapler Assembly is not secured. Support it from the lower side with your hand so that it does not drop.
15. Remove two Screw that secure to the Finisher from the Stapler Assembly. (Figure 3)
  16. Lift the front of the Stapler Assembly a little, and shift them a little toward the front. (Figure 4)
  17. Moving the rear of the Stapler Assembly to the left of the Finisher, and remove the Stapler Assembly.
  18. On the left of the Finisher, insert the Stapler Assembly with the front facing the Finisher.
  19. Protrude the front of the Stapler Assembly a little from the front frame of the Finisher, and align the rear of the Stapler Assembly with the mounting position on the rear of the Finisher.
  20. Align the front of the Stapler Assembly with the mounting position on the front of the Finisher. (Figure 4)
  21. Secure the Stapler Assembly to the Finisher frame with four screws. (Figure 3)
  22. Plug the connector (P/J 1D) of the Harness Middle Stapler to the Cable-Flat. (Figure 2)

## 4025-Finisher

- 23.** Plug the connector (CN 8) of the Harness Motor to the Motor Assembly-MP8.  
(Figure 2)
- 24.** Mount the Latch Assembly and Switch Docking.
- 25.** Align the Cover Upper Left Assembly, with the mounting position in the frame of the Finisher, and secure it with six screws. (Figure 1)
- 26.** Mount the Inner Cover.
- 27.** Mount the Stapler Assembly.
- 28.** Mount the Cover-Open, Front, Cover-Front and Kit Stud Cover.
- 29.** Mount the Cover-Rear.
- 30.** Mount the Cover-Top, Front and Cover-Top, Rear.
- 31.** Mount the Cover-Jogging.
- 32.** Mount the Bottle Assembly-Dust.
- 33.** Mount the Cartridge.

## Stapler II Assembly Removal

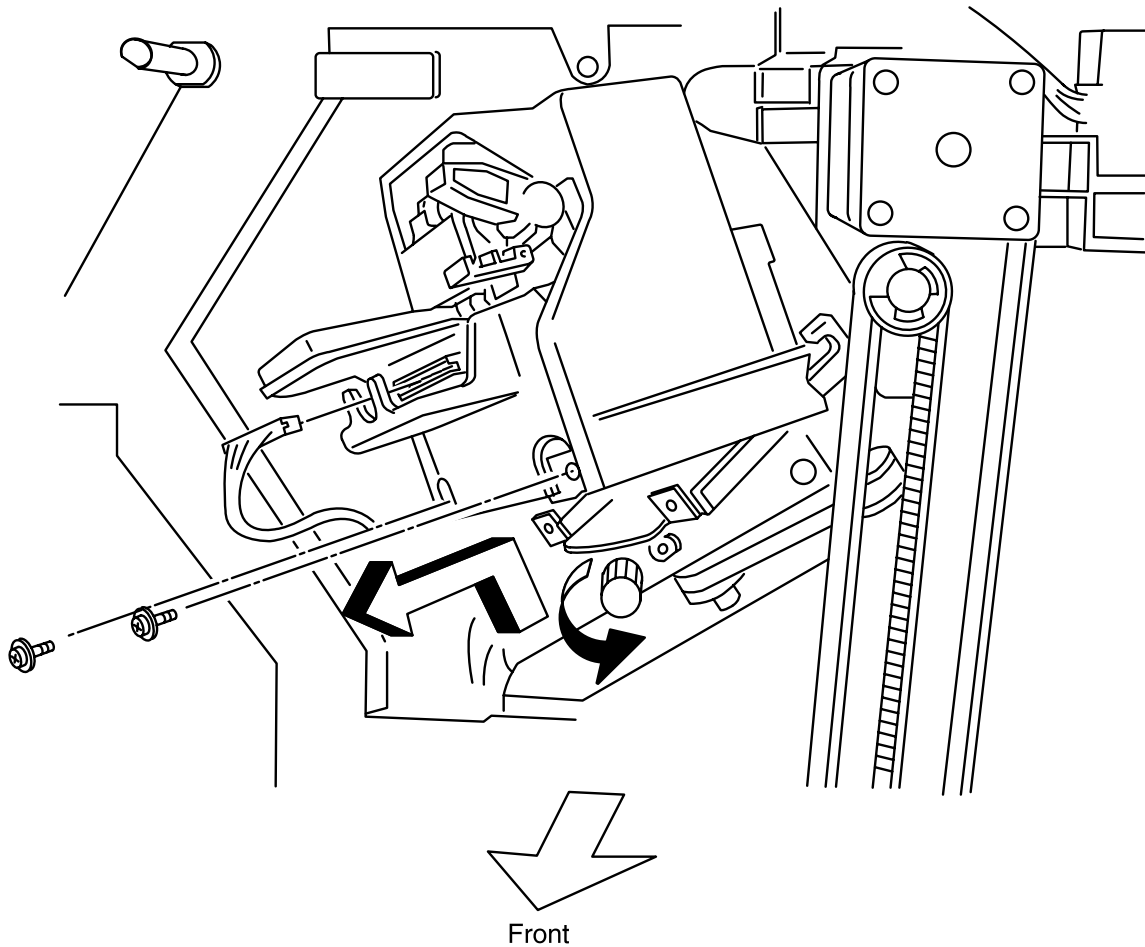

### Removal

1. Open the Cover-Open, Front.
2. Unplug the connector (CN 10) of the Stapler harness assembly from the Stapler Assembly.
3. Turn the knob of the stapler counterclockwise to face the stapler toward the front.
4. Remove two screws that secure to the Stapler Assembly from the Stapler Holder.
5. Lifting up the front of the Stapler Assembly, and pull it off.

### Replacement

1. Holding the shaft on the front of the Stapler Assembly to the hook of the Stapler Holder, align the hole on the front of the Stapler Assembly with the screw hole in the Stapler Holder.
2. Secure the Stapler Holder to the Stapler Assembly with two screws.
3. Plug the connector (CN 10) of the Stapler harness assembly to the Stapler Assembly.
4. Close the Cover-Open, Front.

## Stapler Harness Assembly Removal

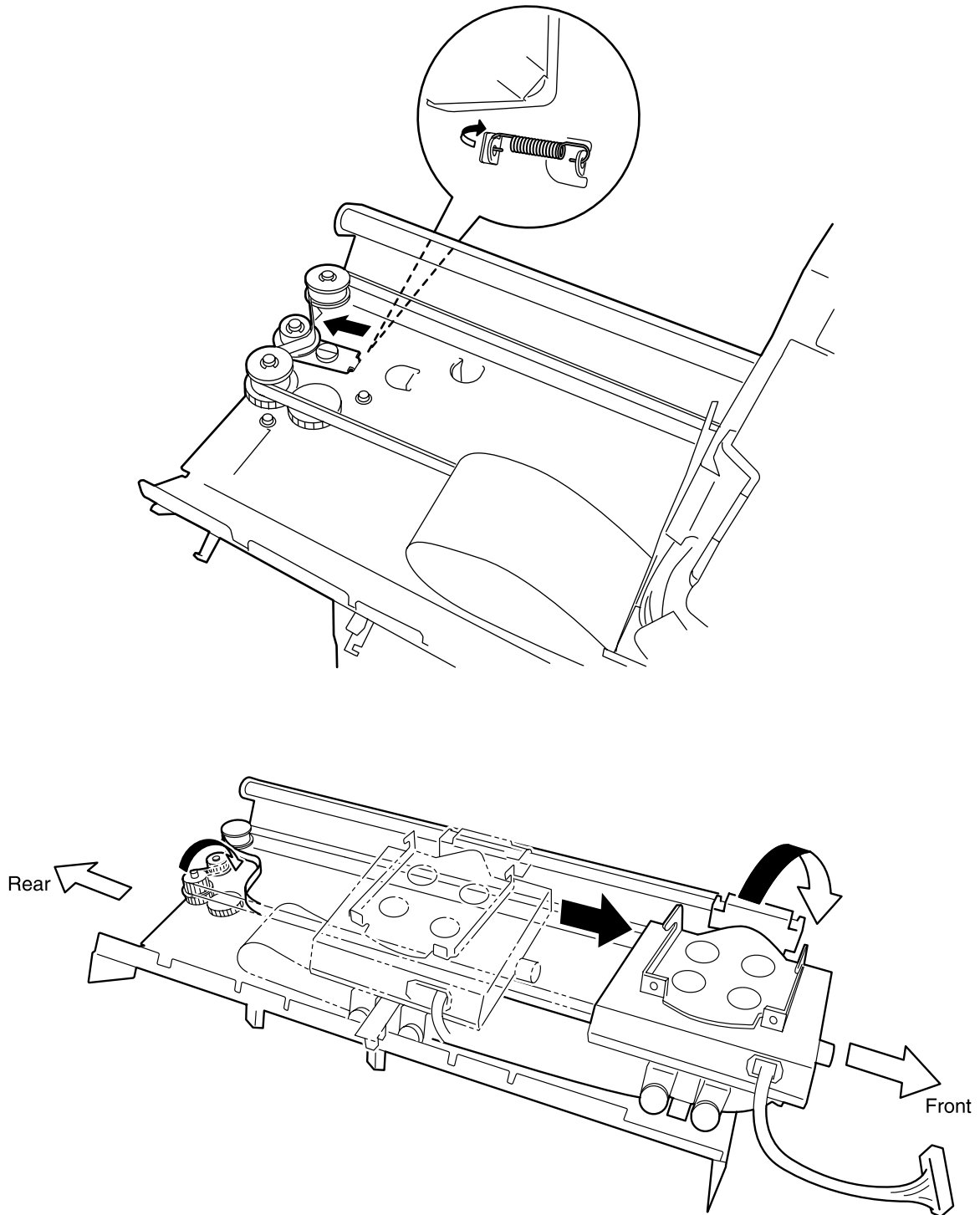

## 4025-Finisher

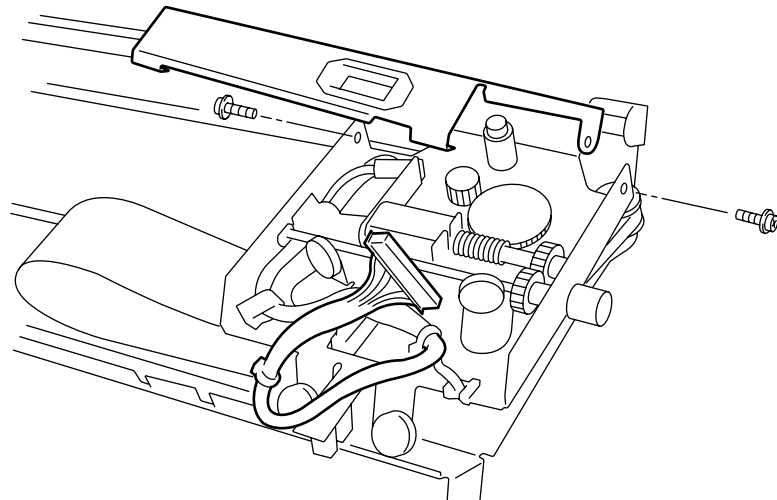
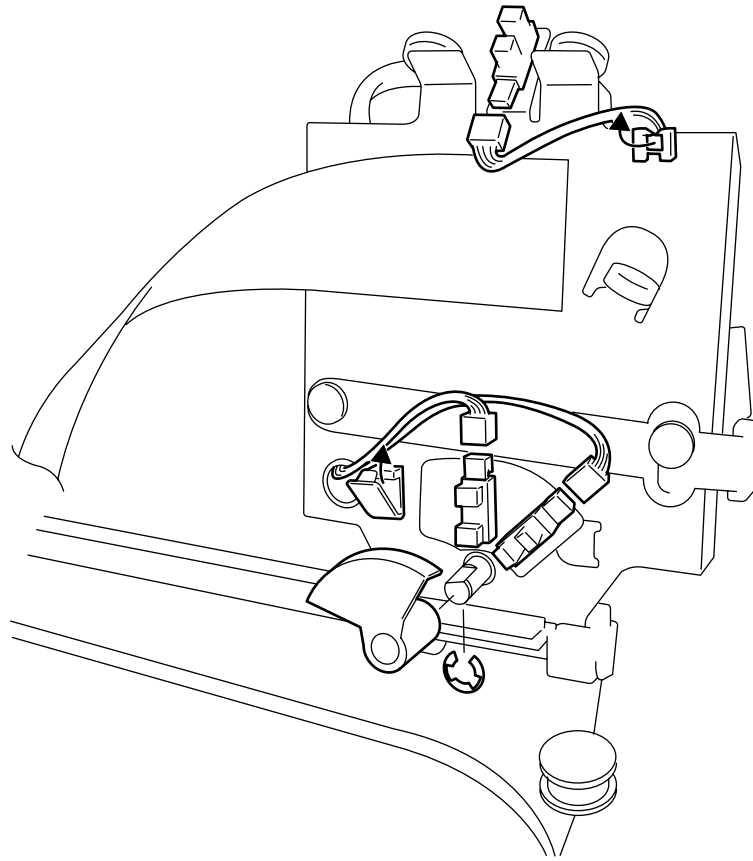

## 4025-Finisher

### Removal

1. Remove the Cartridge and the Bottle Assembly-Dust.
2. Remove the Cover-Jogging.
3. Remove the Cover-Top, Front and Cover-Top, Rear.
4. Remove the Cover-Rear.
5. Remove the Cover-Open, Front, Cover-Front and Kit Stud Cover.
6. Remove the Stapler Assembly.
7. Remove the Inner Cover.
8. Remove six screws that secure the Cover Upper Left Assembly to the frame of the Finisher, and remove the Cover Upper Left Assembly.
9. Remove the Latch Assembly and Switch Docking.
10. Remove the Stapler Assembly.
11. Unhook the Spring on the back of the stapler. (Figure 1)
12. Loosen the Screw and slacken the belt tension.
13. Slide the small plate toward the front. (Figure 2)
14. Open the small plate of the stapler, release two clamps, and disconnect the connector (P/J 10,11,12) connected to the Sensor Assembly-Swing and Sensor. (Figure 3)
15. Disconnect the connector (CN 10) connected to the Stapler Assembly. (Figure 4)
16. Remove two screws that secure the Stapler Bottom Cover, and shift the Stapler Bottom Cover toward the right to remove, and pull the connector out of the hole in the Stapler Assembly.
17. Release one clamp on the small plate, and disconnect the connector (P/J CN9) connected to the Motor Assembly-Swing.

### Replacement

1. Connect the connector (P/J CN9) of the Motor Assembly-Swing, and bundle the wires with a clamp.
2. Place the connector (P/J CN10) of the Stapler harness assembly through the hole and connect it to the Stapler Assembly.
3. Open the small plate of the stapler, connect three connectors (P/J 10,11,12), and bundle the wires with two clamps. (Figure 3)
4. Close the small plate together with the Stapler Holder. (Figure 2)
5. Adjust the belt tension by relocating the tension roller, and then tighten the screw. (Figure 1)
6. Mount the Stapler Assembly.
7. Mount the Latch Assembly and Switch Docking.
8. Align the Cover Upper Left Assembly, with the mounting position in the frame of the Finisher, and secure them with six screws.
9. Mount the Inner Cover and the Stapler Assembly.
10. Mount the Cover-Open, Front, Cover-Front and Kit Stud Cover.
11. Mount the Cover-Rear.
12. Mount the Cover-Top, Front and Cover-Top, Rear.
13. Mount the Cover-Jogging.
14. Mount the Bottle Assembly-Dust.
15. Mount the Cartridge.



## Cartridge Removal

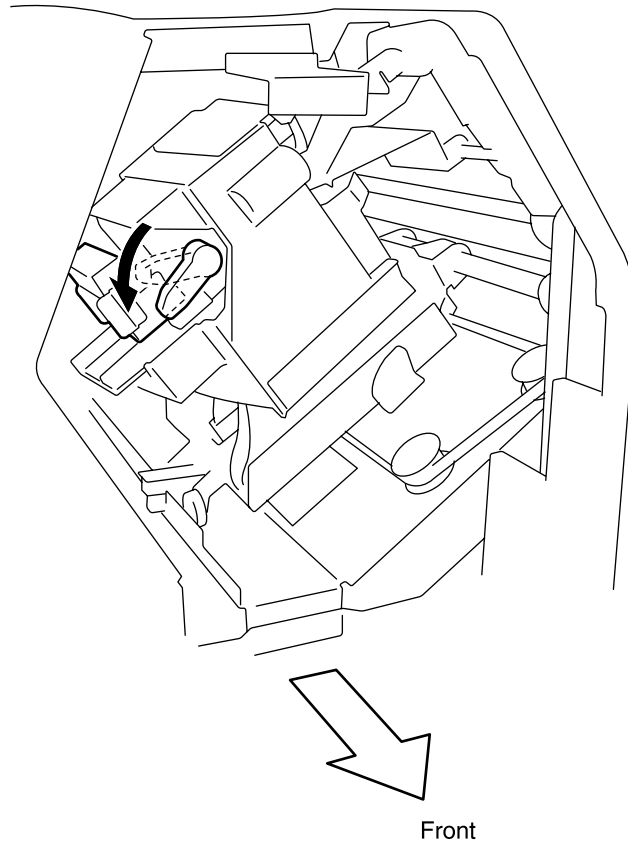

### Removal

1. Open the Cover-Open, Front.
2. Lower the Lever of Stapler Assembly, and remove the Cartridge.

### Replacement

1. Insert the Cartridge into the insertion slot of the Stapler Assembly to mount the Cartridge.
2. Close the Cover-Open, Front.

## Traverse Motor Assembly Removal

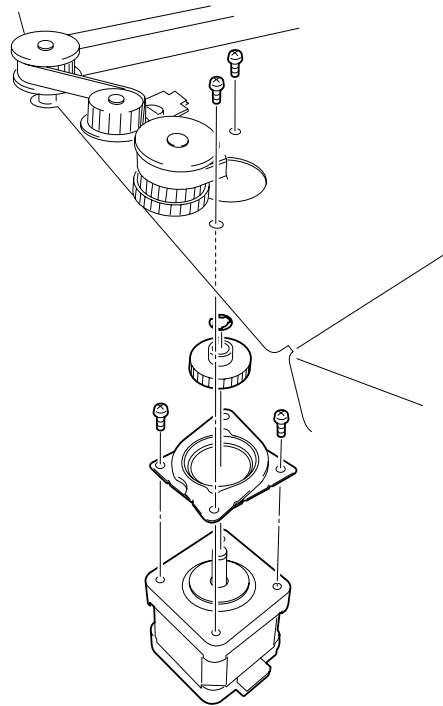

### Removal

1. Remove the Cartridge.
2. Remove the Bottle Assembly-Dust.
3. Remove the Cover-Jogging.
4. Remove the Cover-Top, Front and Cover-Top, Rear.
5. Remove the Cover-Rear.
6. Remove the Cover-Open, Front, Cover-Front and Kit Stud Cover.
7. Remove the Inner Cover.
8. Remove six screws that secure the Cover Upper Left Assembly to the frame of the Finisher, and remove the Cover Upper Left Assembly.
9. Remove the Latch Assembly and Switch Docking.
10. Remove the Stapler Assembly.
11. Unplug the connector (CN 8) of the Harness Motor from the Motor Assembly-MP8.
12. Remove two screws that secure the Damper to the large frame of the stapler, and remove the Damper together with the Gear and Motor Assembly-MP8.
13. Remove the E-ring that secures the Gear to the shaft of the Motor Assembly-MP8, and remove the Gear.
14. Remove two screws that secure the Motor Assembly-MP8 to the Damper, and remove the Motor Assembly-MP8.

## Replacement

1. Align the Motor Assembly-MP8 with the mounting position in the Damper, and secure it with two screws.
2. Insert the Gear into the shaft of the Motor Assembly-MP8, and secure it with an E-ring.
3. Align the Damper, together with the Gear and Motor Assembly-MP8, with the large frame of the stapler, and secure them with two screws.
4. Plug the connector (CN 8) of the Harness Motor to the Motor Assembly-MP8.
5. Mount the Latch Assembly and Switch Docking.
6. Align the Cover Upper Left Assembly, with the mounting position in the frame of the Finisher, and secure them with six screws.
7. Mount the Inner Cover.
8. Mount the Cover-Open, Front, Cover-Front and Kit Stud Cover.
9. Mount the Cover-Rear.
10. Mount the Cover-Top, Front and Cover-Top, Rear.
11. Mount the Cover-Jogging.
12. Mount the Bottle Assembly-Dust.
13. Mount the Cartridge.

## Motor Assembly-Swing Removal

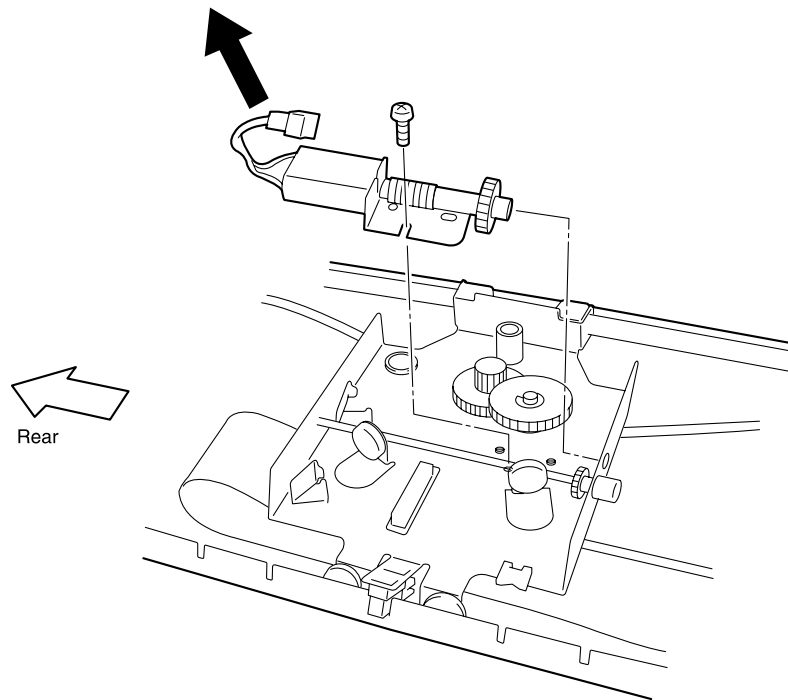

### Removal

1. Remove the Cartridge.
2. Remove the Bottle Assembly-Dust.
3. Remove the Cover-Jogging.
4. Remove the Cover-Top, Front and Cover-Top, Rear.
5. Remove the Cover-Rear.
6. Remove the Cover-Open, Front, Cover-Front and Kit Stud Cover.
7. Remove the Stapler Assembly.
8. Remove the Inner Cover.
9. Remove six screws that secure the Cover Upper Left Assembly to the Finisher frame, and remove the Cover Upper Left Assembly.
10. Remove the Latch Assembly and Switch Docking.
11. Remove the Stapler Assembly.
12. Remove the Stapler harness assembly.
13. Unplug the connector (CN 9) of the Stapler harness assembly from the Motor Assembly-Swing.
14. Remove the screw that secures the Motor Assembly-Swing, and remove the Motor Assembly-Swing in diagonal upper rear direction.

## Replacement

1. From the diagonal upper rear direction, mount the Motor Assembly-Swing so that the shaft can enter.
2. Plug the connector (CN 9) of the Stapler harness assembly to the Motor Assembly-Swing.
3. Mount the Stapler harness assembly.
4. Mount the Stapler Assembly.
5. Mount the Latch Assembly and Switch Docking.
6. Align the Cover Upper Left Assembly, with the mounting position in the Finisher frame, and secure them with six screws.
7. Mount the Inner Cover.
8. Mount the Stapler Assembly.
9. Mount the Cover-Open, Front, Cover-Front and Kit Stud Cover.
10. Mount the Cover-Rear.
11. Mount the Cover-Top, Front and Cover-Top, Rear.
12. Mount the Cover-Jogging.
13. Mount the Bottle Assembly-Dust.
14. Mount the Cartridge.

## Sensor Assembly Swing Removal

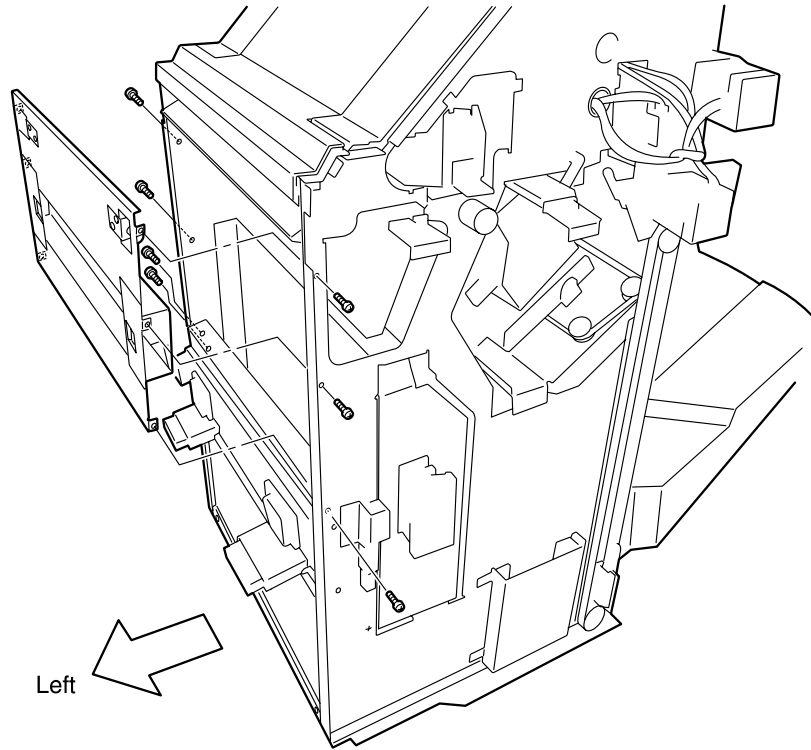

# 4025-Finisher

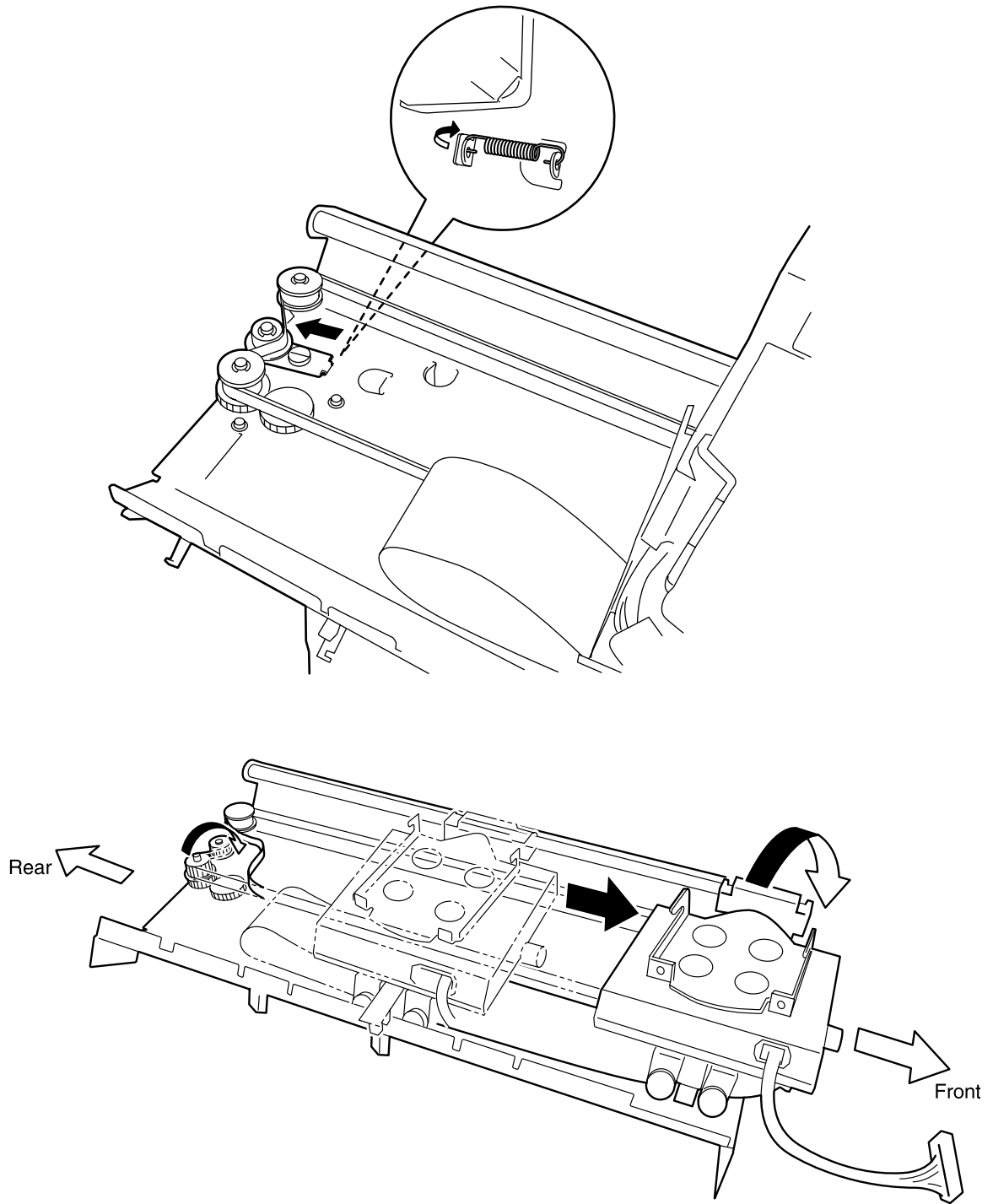

# 4025-Finisher

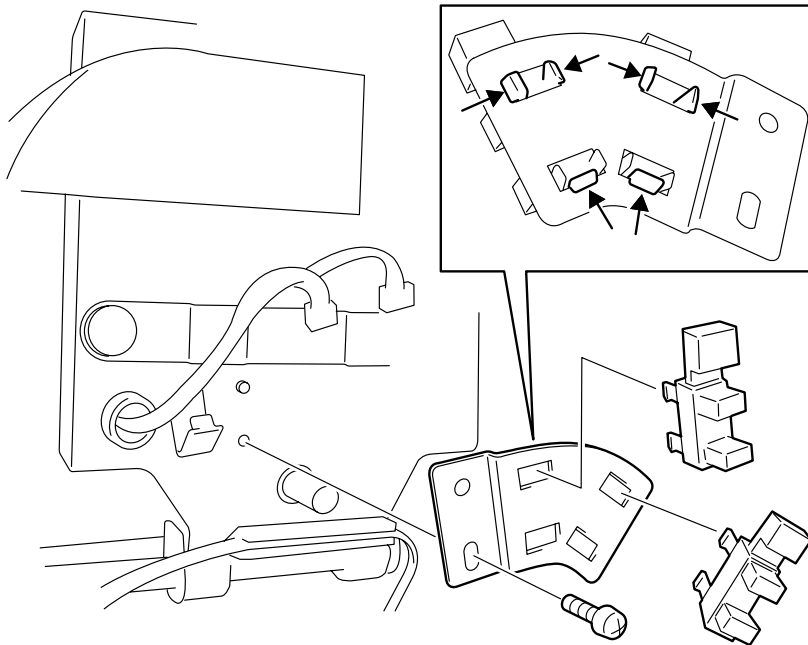
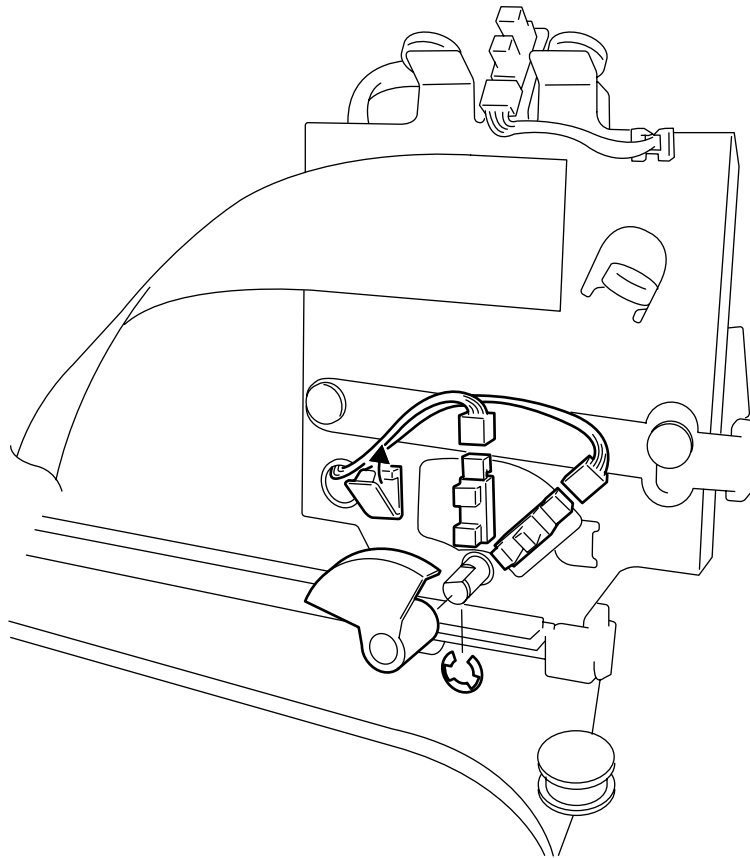



## 4025-Finisher

### Removal

1. Remove the Cartridge.
2. Remove the Bottle Assembly-Dust.
3. Remove the Cover-Jogging.
4. Remove the Cover-Top, Front and Cover-Top, Rear.
5. Remove the Cover-Rear.
6. Remove the Cover-Open, Front, Cover-Front and Kit Stud Cover.
7. Remove the Stapler Assembly.
8. Remove the Inner Cover.
9. Remove six screws that secure the Cover Upper Left Assembly to the Finisher frame, and remove the Cover Upper Left Assembly. (Figure 1)
10. Remove the Latch Assembly and Switch Docking.
11. Remove the Stapler Assembly.
12. Remove the Stapler harness assembly
13. Remove the E-ring that secures the Sector Gear to the shaft of the stapler, and pull off the Sector Gear.
14. Remove the screw that secures the Sensor Assembly-Swing, and remove the Sensor Assembly-Swing.

### Replacement

1. Mount the screw that secures the Sensor Assembly-Swing, and mount the Sensor Assembly-Swing.
2. Insert the Sector Gear into the shaft of the stapler, and secure it with an E-ring.
3. Mount the Stapler harness assembly
4. Mount the Stapler Assembly.
5. Mount the Latch Assembly and Switch Docking.
6. Align the Cover Upper Left Assembly, with the mounting position in the frame of the Finisher, and secure them with six screws. (Figure 1)
7. Mount the Inner Cover.
8. Mount the Stapler Assembly
9. Mount the Cover-Open, Front, Cover-Front and Kit Stud Cover.
10. Mount the Cover-Rear.
11. Mount the Cover-Top, Front and Cover-Top, Rear.
12. Mount the Cover-Jogging.
13. Mount the Bottle Assembly-Dust.
14. Mount the Cartridge.

## Belt Removal

### Removal

**Note:** Reference the illustrations in the “**Sensor Assembly Swing Removal**” on page 4-106.

1. Remove the Cartridge.
2. Remove the Bottle Assembly-Dust.
3. Remove the Cover-Jogging.
4. Remove the Cover-Top, Front and Cover-Top, Rear.
5. Remove the Cover-Rear.
6. Remove the Cover-Open, Front, Cover-Front and Kit Stud Cover.
7. Remove the Stapler Assembly.
8. Remove the Inner Cover.
9. Remove six screws that secure the Cover Upper Left Assembly to the Finisher frame, and remove the Cover Upper Left Assembly. (Figure 1)
10. Remove the Latch Assembly and Switch Docking.
11. Remove the Stapler Assembly.
12. Unhook the Spring on the back of the stapler. (Figure 2)
13. Slide the small plate toward the front. (Figure 3)
14. Disengage the Belt from the gear to which a driving force is transmitted directly from the Motor Assembly-MP8 on the large frame of the stapler.
15. Turn down the Stapler Assembly together with the small frame of the stapler toward the right. (Figure 3)
16. Pull the Belt off the flat gear on the small frame of the stapler. (Figure 3)
17. Remove the Belt from the large frame of the stapler.

### Replacement

1. Engage the Belt with the flat gear on the small frame of the stapler. (Figure 3)
2. Engage the Belt with three gears on the large frame of the stapler.
3. Close the small plate together with the Stapler Holder. (Figure 3)
4. Engage the Belt with the gear to which a driving force is transmitted directly from the Motor Assembly-MP8 on the large frame of the stapler.
5. Hook the Spring on the back of the stapler. (Figure 2)
6. Mount the Stapler Assembly.
7. Mount the Latch Assembly and Switch Docking.
8. Align the Cover Upper Left Assembly, with the mounting position in the frame of the Finisher, and secure them with six screws.(Figure 1)
9. Mount the Inner Cover.
10. Mount the Stapler Assembly.
11. Mount the Cover-Open, Front, Cover-Front and Kit Stud Cover.
12. Mount the Cover-Rear.
13. Mount the Cover-Top, Front and Cover-Top, Rear.
14. Mount the Cover-Jogging.
15. Mount the Bottle Assembly-Dust.
16. Mount the Cartridge.

## Cable, Flat Removal

**Note:** Reference the illustrations in the “**Sensor Assembly Swing Removal**” on **page 4-106**.

### Removal

1. Remove the Cartridge.
2. Remove the Bottle Assembly-Dust.
3. Remove the Cover-Jogging.
4. Remove the Cover-Top, Front and Cover-Top, Rear.
5. Remove the Cover-Rear.
6. Remove the Cover-Open, Front, Cover-Front and Kit Stud Cover.
7. Remove the Stapler Assembly
8. Remove the Inner Cover.
9. Remove six screws that secure the Cover Upper Left Assembly to the Finisher frame, and remove the Cover Upper Left Assembly. (Figure 1)
10. Remove the Latch Assembly and Switch Docking.
11. Remove the Stapler Assembly.
12. Unhook the Spring on the back of the stapler. (Figure 2)
13. Slide the small plate toward the front. (Figure 3)
14. Disengage the Belt from the gear to which a driving force is transmitted directly from the Motor Assembly-MP8 on the large frame of the stapler.
15. Turn down the Stapler Assembly together with the small frame of the stapler toward the right. (Figure 3)
16. Remove two screws that secure to the small frame of the stapler from the Cable-Flat.
17. Remove two screws that secure to the large frame of the stapler from the Cable-Flat, and then remove the Cable-Flat.

## 4025-Finisher

### Replacement

1. Align the Cable-Flat with the mounting position in the large frame of the stapler, and secure it with two screws.
2. Align the Cable-Flat with the mounting position in the small frame of the stapler, and secure it with two screws.
3. Close the small plate together with the Stapler Holder. (Figure 3)
4. Engage the Belt with the gear to which a driving force is transmitted directly from the Motor Assembly-MP8 on the large frame of the stapler.
5. Hook the Spring on the back of the stapler. (Figure 2)
6. Mount the Stapler Assembly.
7. Mount the Latch Assembly and Switch Docking.
8. Align the Cover Upper Left Assembly, with the mounting position in the frame of the Finisher, and secure them with six screws. (Figure 1)
9. Mount the Inner Cover.
10. Mount the Stapler Assembly
11. Mount the Cover-Open, Front, Cover-Front and Kit Stud Cover.
12. Mount the Cover-Rear.
13. Mount the Cover-Top, Front and Cover-Top, Rear.
14. Mount the Cover-Jogging.
15. Mount the Bottle Assembly-Dust.
16. Mount the Cartridge.

## Sensor, Stapler Home Position Traverse Removal

### Removal

1. Remove the Cartridge.
2. Remove the Bottle Assembly-Dust.
3. Remove the Cover-Jogging.
4. Remove the Cover-Top, Front and Cover-Top, Rear.
5. Remove the Cover-Rear.
6. Remove the Cover-Open, Front, Cover-Front and Kit Stud Cover.
7. Remove the Stapler Assembly
8. Remove the Inner Cover.
9. Remove six screws that secure the Cover Upper Left Assembly to the Finisher frame, and remove the Cover Upper Left Assembly. Reference the illustrations in the **“Sensor Assembly Swing Removal” on page 4-106**. (Figure 1)
10. Remove the Latch Assembly and Switch Docking.
11. Remove the Stapler Assembly.
12. Unhook the Spring on the back of the stapler. (Figure 2)
13. Slide the small plate toward the front. (Figure 3)
14. Disengage the Belt from the gear to which a driving force is transmitted directly from the Motor Assembly-MP8 on the large frame of the stapler.
15. Turn down the Stapler Assembly together with the small frame of the stapler toward the right. (Figure 3)
16. Unplug the connector (P/J 10) of the Stapler harness assembly from the Sensor.
17. Unhook the Sensor at three places, and remove it.(Figure 4)

### Replacement

1. Align the Sensor with the mounting position in the small frame of the stapler, and mount it. (Figure 4)
2. Plug the connector (P/J 10) of the Stapler harness assembly to the Sensor.
3. Close the small plate together with the Stapler Holder. (Figure 3)
4. Engage the Belt with the gear to which a driving force is transmitted directly from the Motor Assembly-MP8 on the large frame of the stapler.
5. Hook the Spring on the back of the stapler. (Figure 2)
6. Mount the Stapler Assembly.
7. Mount the Latch Assembly and Switch Docking.
8. Align the Cover Upper Left Assembly, with the mounting position in the frame of the Finisher, and secure them with six screws.(Figure 1)
9. Mount the Inner Cover.
10. Mount the Stapler Assembly
11. Mount the Cover-Open, Front, Cover-Front and Kit Stud Cover.
12. Mount the Cover-Rear.
13. Mount the Cover-Top, Front and Cover-Top, Rear.
14. Mount the Cover-Jogging.
15. Mount the Bottle Assembly-Dust.
16. Mount the Cartridge.

## Kit Bearing Removal

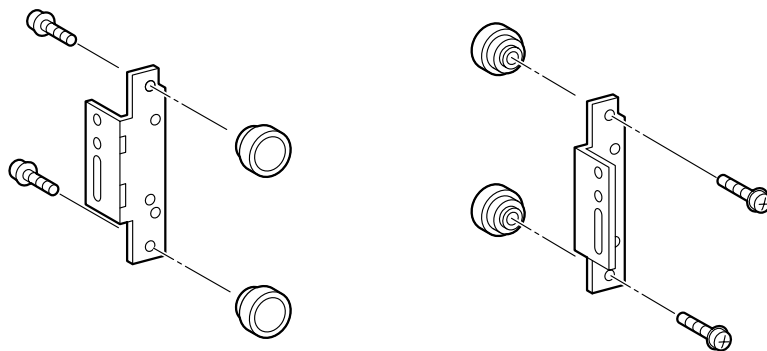
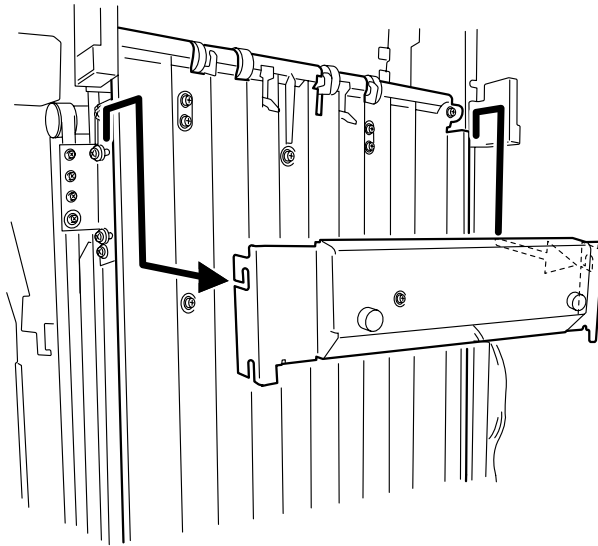

### Removal

1. Remove the Cover-Jogging.
2. Remove the Cover-Top, Front and Cover-Top, Rear.
3. Remove the Cover-Rear.
4. Remove the Cover-Open, Front, Cover-Front and Kit Stud Cover.
5. Remove the Tray-Lower.
6. On the Front of the Finisher, loosen the two screws that secure the Bracket Tray Lower.
7. On the Rear of the Finisher, loosen the two screws that secure the Bracket Tray Lower, and Remove the Bracket Tray Lower.
8. Remove the Holder Assembly.
9. Remove the screw that secures the Bearing Assembly to the Bracket Front, and remove the Bearing Assembly. (Figure 2)
10. Repeat the above steps until you have removed all the Bearing Assembly.

## **Replacement**

- 1.** Align the Bearing Assembly with the mounting position in the Bracket Front, and secure it with a screw. (Figure 2)
- 2.** Repeat the above step until you have mounted all the Bearing Assembly.
- 3.** Mount the Holder Assembly.
- 4.** Align the Bracket Tray Lower, with the mounting position, and secure them with four screws.
- 5.** Mount the Tray-Lower.
- 6.** Mount the Cover-Open, Front, Cover-Front and Kit Stud Cover.
- 7.** Mount the Cover-Rear.
- 8.** Mount the Cover-Top, Front and Cover-Top, Rear.
- 9.** Mount the Cover-Jogging.

## Holder Assembly Removal

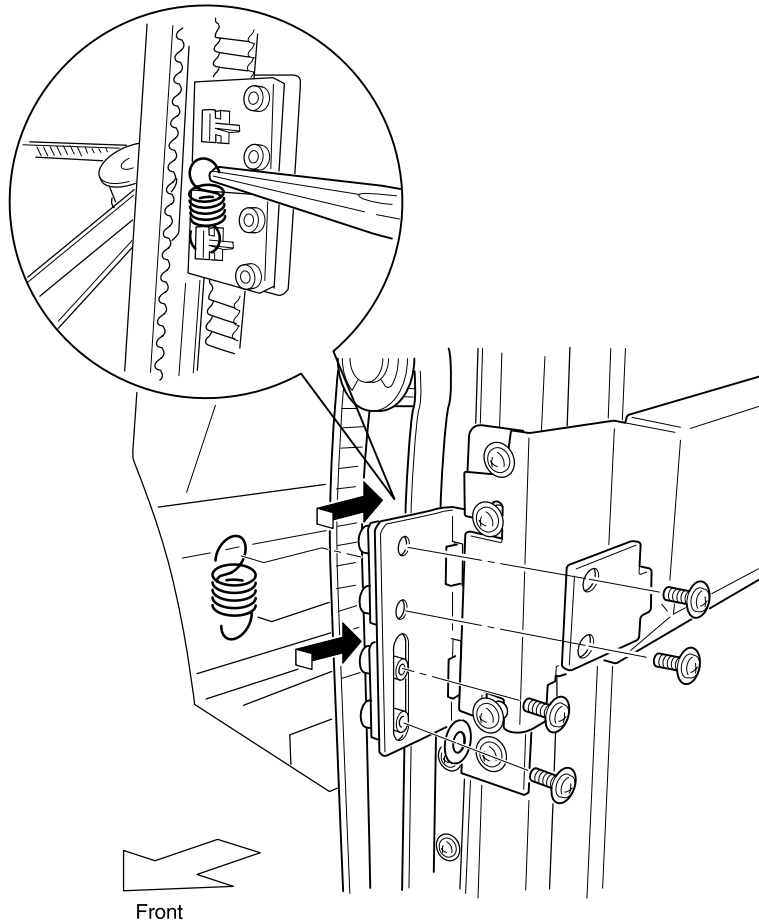

### Removal

1. Remove the Cover-Jogging.
2. Remove the Cover-Top, Front and Cover-Top, Rear.
3. Remove the Cover-Rear.
4. Remove the Cover-Open, Front, Cover-Front and Kit Stud Cover.

**Note:** In the following steps, the procedure on the front is the same as on the rear. Apply the same procedure to the rear.

5. Remove two screws that secure the lower Holder to the Bracket Front.
6. Disengage the Spring from the upper and lower Holder using radio pliers, and remove the Spring.
7. Remove two screws that secure the upper Holder to the Bracket.
8. Disengage the screw hole in the upper Holder from the hole in the Bracket Front, and push the upper Holder inside to remove it.
9. Disengage the screw hole in the lower Holder from the hole in the Bracket Front, and push the lower Holder inside to remove it.
10. Release the Belt from the upper and lower Pulley, and remove it.



### Replacement

**Note:** In the following steps, the procedure on the front is the same as on the rear. Apply the same procedure to the rear.

1. Engage the Belt with the upper and lower Pulley.
2. Engage the Belt with the lower Holder, and align the lower Holder, together with the Belt, with the mounting position.
3. Engage the Belt with the upper Holder so as not to slacken the Pulley, and align the upper Holder, together with the Belt, with the mounting position.
4. Secure the upper Holder to the Bracket Front with two screws.
5. Engage the Spring with the upper and lower Holder using radio pliers.
6. Secure the lower Holder to the Bracket Front with two screws.
7. Mount the Cover-Open, Front, Cover-Front and Kit Stud Cover.
8. Mount the Cover-Rear.
9. Mount the Cover-Top, Front and Cover-Top, Rear.
10. Mount the Cover-Jogging.

## Blade Assembly Removal

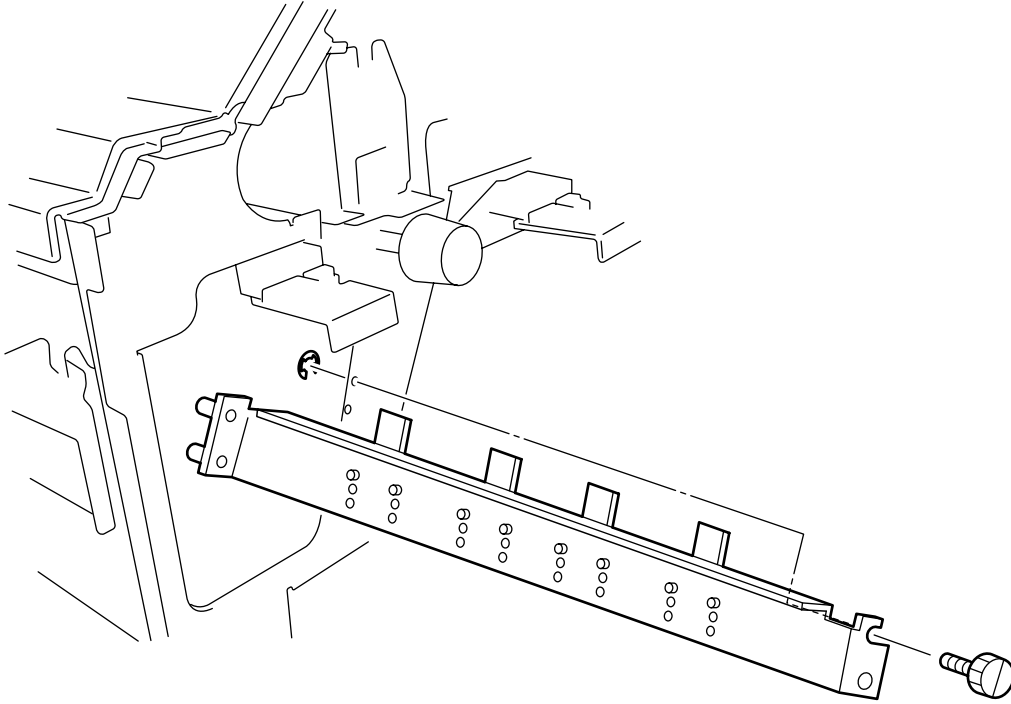

### Removal

1. Remove the Cover-Open, Front, Cover-Front and Kit Stud Cover.
2. Remove two screws on the front that secure to the Finisher from the Blade Assembly, and pull off the Blade Assembly toward the front.

### Replacement

1. Align the Blade Assembly with the mounting position so that the boss on the rear of the Blade Assembly engages with the hole on the rear of the Finisher, and secure it with two screws.
2. Mount the Cover-Open, Front, Cover-Front and Kit Stud Cover.

## Sensor Tray Height Front Removal

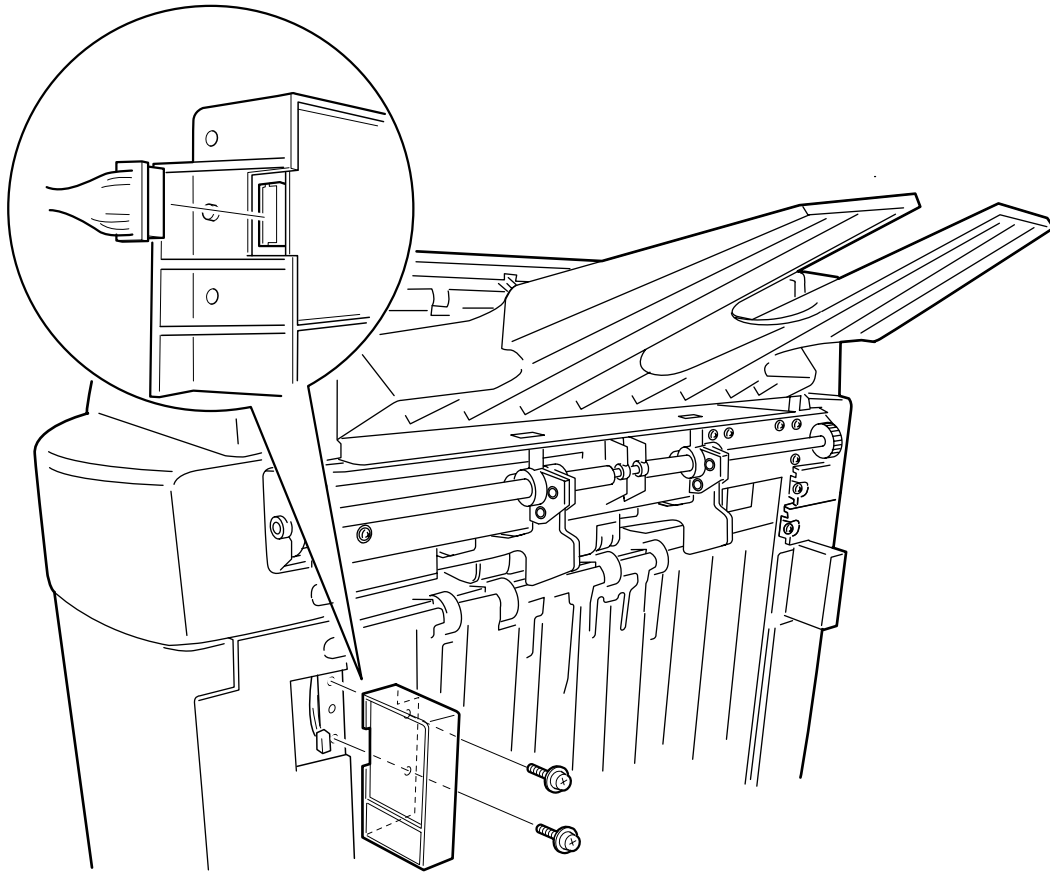

### Removal

1. Remove the Cover-Jogging.
2. Remove two screws that secure to the Finisher from the Sensor Tray Height Front, and pull off the Sensor Tray Height Front a little.
3. Unplug the connector (P/J 1C-L) of the Harness Sensor from the Sensor Tray Height Front.
4. For the rear, perform the above step in the same manner.

### Replacement

1. Plug the connector (P/J 1C-L) of the Harness Sensor to the Sensor Tray Height Front.
2. Align the Sensor Tray Height Front with the mounting position in the Finisher, and secure it with two screws.
3. For the rear, perform the above step in the same manner.
4. Mount the Cover-Jogging.

## Shaft Assembly ELEV U Removal

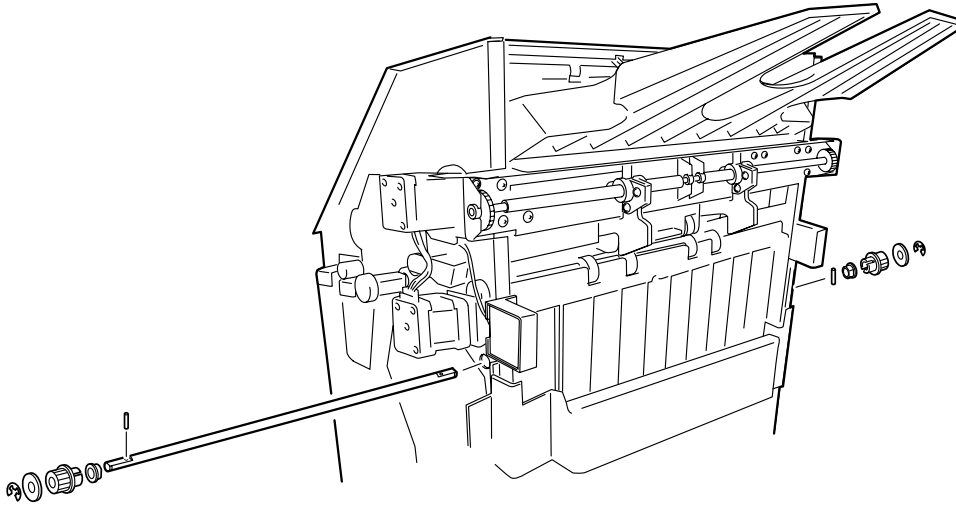

### Removal

1. Remove the Cover-Jogging.
2. Remove the Cover-Top, Front and Cover-Top, Rear.
3. Remove the Cover-Rear.
4. Remove the Cover-Open, Front, Cover-Front and Kit Stud Cover.
5. Remove the Holder Assembly.

**WARNING:** In the following steps, removing the Pulley allows the Pin to be unsecured and easily removed from the Shaft ELEV, U. Take care not to drop or lose it.

6. Remove the E-ring that secures the Bearing and Pulley on the front to the Shaft ELEV, U, and pull off the Pulley, and then pull the Pin off the hole on the front of the Shaft ELEV, U.
7. Remove the E-ring that secures the Bearing and Pulley on the rear to the Shaft ELEV, U, and pull off the Pulley, and then pull the Pin off the hole on the rear of the Shaft ELEV, U.
8. Remove the front and rear Bearings that secure the Shaft ELEV, U to the Finisher.
9. Pull the Shaft ELEV, U off the Finisher.

### Replacement

1. Insert the Shaft ELEV, U into the Finisher.
2. Mount the Bearing on the front and rear of the Shaft ELEV, U.
3. Insert the Pin into the hole on the rear of the Shaft ELEV, U and the Pulley into the rear of the Shaft ELEV, U, and secure them with an E-ring.
4. Insert the Pin into the hole on the front of the Shaft ELEV, U and the Pulley into the front of the Shaft ELEV, U, and secure them with an E-ring.
5. Mount the Holder Assembly.
6. Mount the Cover-Open, Front, Cover-Front and Kit Stud Cover.
7. Mount the Cover-Rear, the Cover-Top, Front and Cover-Top.
8. Mount the Cover-Jogging.

### Shaft Assembly ELEV L Removal

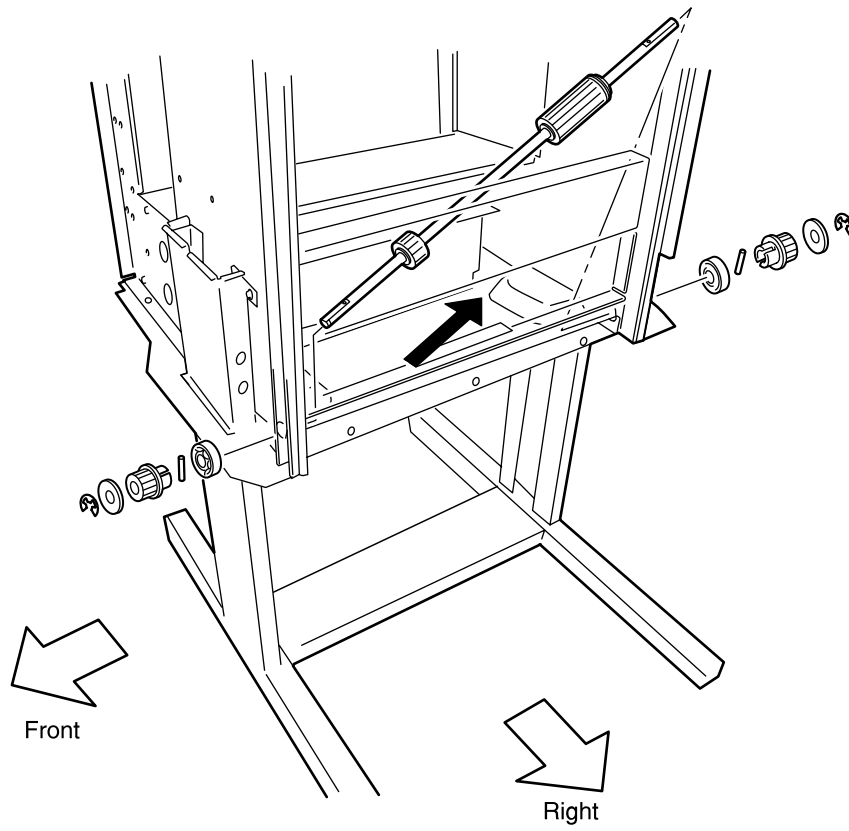

### Removal

1. Remove the Cover-Jogging.
2. Remove the Cover-Top, Front and Cover-Top, Rear.
3. Remove the Cover-Rear.
4. Remove the Cover-Open, Front, Cover-Front and Kit Stud Cover.
5. Remove the Right Cover.
6. Remove the Drive Assembly-ELEV and Motor Assembly-MD11.
7. Remove the Encorder Assembly.
8. Remove the Holder Assembly.

**WARNING:** In the following steps, removing the Pulley allows the Pin to be unsecured and easily removed from the Shaft ELEV,L. Take care not to drop or lose it.

9. Remove the E-ring that secures the Gear to the Shaft ELEV,L, slide the Gear toward the front, and remove the Pin.
10. Remove the E-ring that secures the Encorder Drive Pulley to the Shaft ELEV,L, slide the Gear toward the rear, and remove the Encorder Drive Pulley.
11. Remove the E-ring that secures the Bearing and Pulley on the front to the Shaft ELEV,L, and pull off the Pulley, and then pull the Pin off the hole on the front of the Shaft ELEV,L.
12. Remove the E-ring that secures the Bearing and Pulley on the rear to the Shaft ELEV,L, and pull off the Pulley, and then pull the Pin off the hole on the rear of the Shaft ELEV,L.
13. Remove the front and rear Bearings that secure the Shaft ELEV,L to the Finisher, and pull off the Shaft ELEV,L.

## 4025-Finisher

### Replacement

1. Insert the Shaft ELEV,L a little into the hole on the front of the Finisher, then at the inside of the Finisher, insert the Gear and Encorder Drive Pulley up to the hole on the rear of the Finisher.
2. Insert the Bearing into the front of the Shaft ELEV,L.
3. Insert the Pin into the hole on the front of Shaft ELEV,L, and then insert the Pulley into the Shaft ELEV,L so that the slit of the Pulley is in position.
4. Secure the front of the Shaft ELEV,L with an E-ring.
5. For the rear, perform the above steps (2-4) in the same manner.
6. At the inside of the Finisher, insert the Pin into the hole on the front, and then slide the Gear up to its mounting position so that the slit of the Gear is in position.
7. Secure the front of the Gear with an E-ring.
8. At the inside of the Finisher, insert the Pin into the hole on the rear, and then slide the Encorder Drive Pulley up to its mounting position so that the slit of the Encorder Drive Pulley is in position.
9. Secure the front of the Encorder Drive Pulley with an E-ring.
10. Mount the Holder Assembly.
11. Mount the Encorder Assembly.
12. Mount the Drive Assembly-ELEV and Motor Assembly-MD11.
13. Mount the Right Cover.
14. Mount the Cover-Open, Front, Cover-Front and Kit Stud Cover.
15. Mount the Cover-Rear.
16. Mount the Cover-Top, Front and Cover-Top, Rear.
17. Mount the Cover-Jogging.

## Drive Assembly-ELEV, Motor Assembly-MD11 Removal

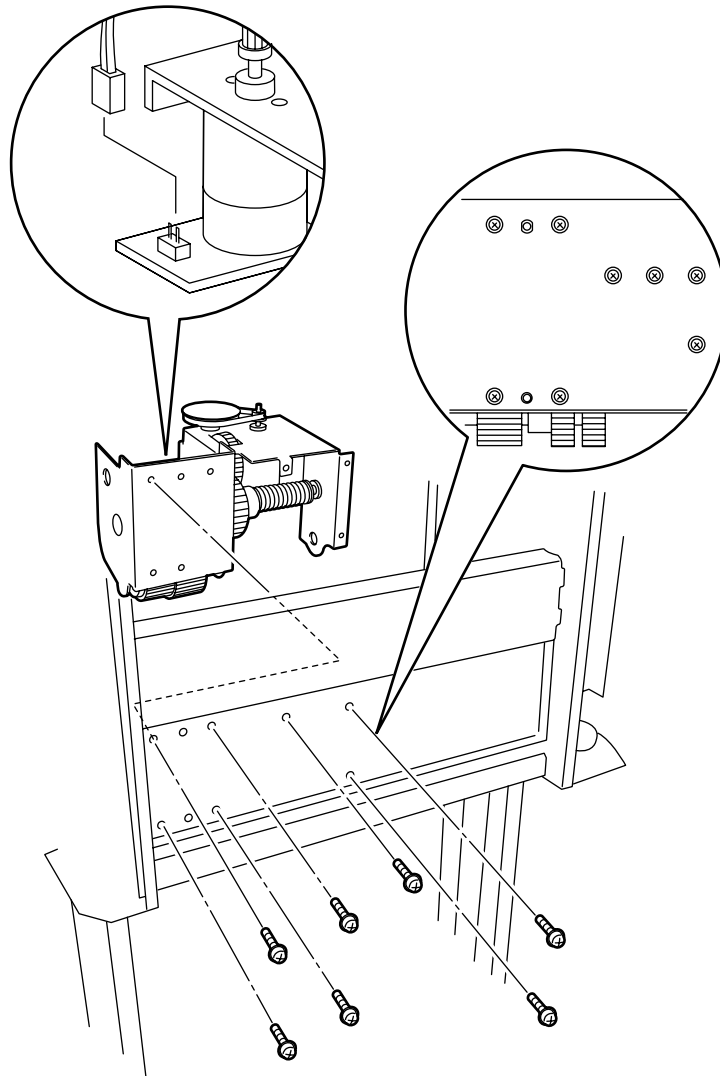



## 4025-Finisher

### Removal

1. Remove the Cover-Jogging.
2. Remove the Tray-Lower.
3. Remove the Cover-Top, Front and Cover-Top, Rear.
4. Remove the Cover-Rear.
5. Remove the Cover-Open, Front, Cover-Front and Kit Stud Cover.
6. Remove the Right Cover.
7. Remove the Latch Assembly and Switch Docking.
8. Remove the Inner Cover.
9. Unplug the connector (CN 11) of the Harness DC from the Motor Assembly-MD11.
10. Remove the screws that secure the Drive Assembly-ELEV, and remove the Drive Assembly-ELEV.
11. Remove the screws that secure the Drive Assembly-ELEV, and remove the Motor Assembly-MD11.

### Replacement

1. Align the Motor Assembly-MD11 with the mounting position in the Drive Assembly-ELEV, and secure it with the screws.
2. Align the Motor Assembly-MD11 and Drive Assembly-ELEV with the stay position in the Finisher, and secure with the screws.
3. Plug the connector (CN 11) of the Harness DC to the Motor Assembly-MD11.
4. Mount the Inner Cover.
5. Mount the Latch Assembly and Switch Docking.
6. Mount the Right Cover.
7. Mount the Cover-Open, Front, Cover-Front and Kit Stud Cover.
8. Mount the Cover-Rear.
9. Mount the Cover-Top, Front and Cover-Top, Rear.
10. Mount the Tray-Lower.
11. Mount the Cover-Jogging.

## Right Cover Removal

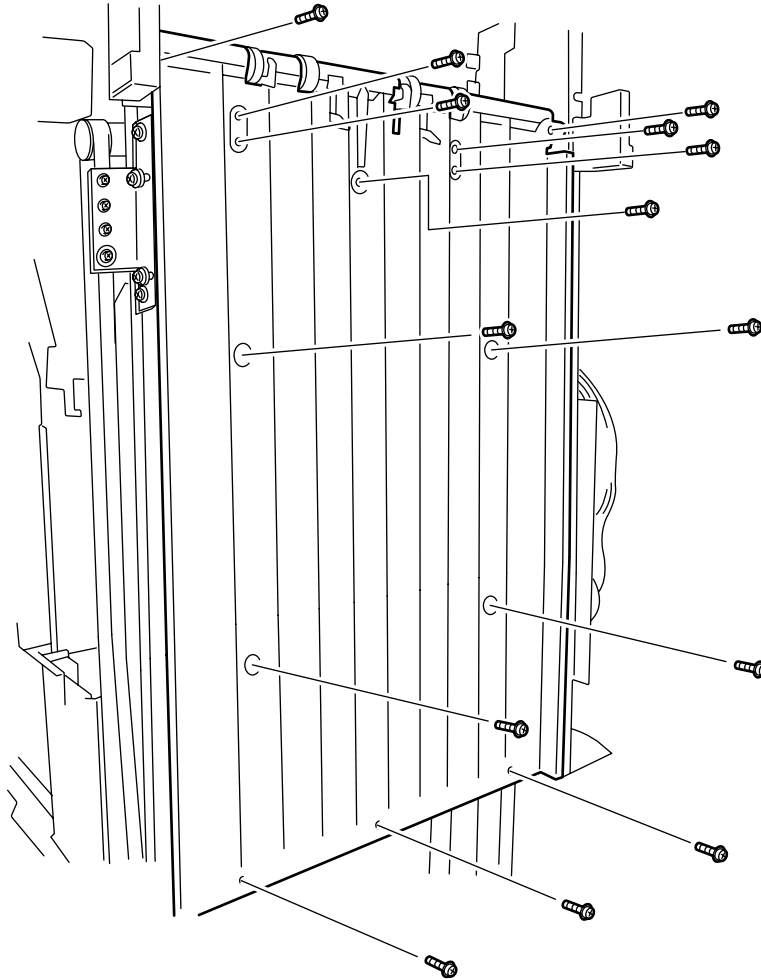
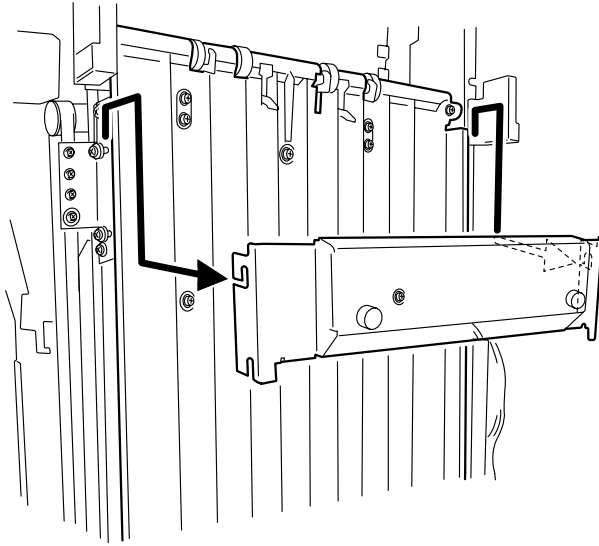

## 4025-Finisher

### Removal

1. Remove the Cover-Jogging.
2. Remove the Tray-Lower.
3. Remove the Cover-Top, Front and Cover-Top, Rear.
4. Remove the Cover-Rear.
5. Remove the Cover-Open, Front, and Kit Stud Cover.
6. On the Front of the Finisher, loosen the two screws that secure the Bracket Tray Lower.
7. On the Rear of the Finisher, loosen the two screws that secure the Bracket Tray Lower, and Remove the Bracket Tray Lower.
8. Remove seven screws that secure the lower Right Cover to the Bracket (PL20.14.3).
9. Remove two screws that secure the Finisher from the Right Cover.
10. Remove four screws that secure the Stack Arm Assembly from the Right Cover.
11. Remove the screw that secure the No Paper Sensor from the Right Cover.
12. Remove the Right Cover from the Finisher.

### Replacement

1. Align the Right Cover with the mounting position on the Finisher.
2. Secure the Right Cover to the No Paper Sensor with a screw.
3. Secure the Right Cover to the Stack Arm Assembly with four screws.
4. Secure the Right Cover to the Finisher with two screws.
5. Secure the Right Cover to the Finisher with seven screws.
6. Align the Bracket Tray Lower, with the mounting position, and secure it with four screws.
7. Mount the Cover-Open, Front, Cover-Front and Kit Stud Cover.
8. Mount the Cover-Rear.
9. Mount the Cover-Top, Front and Cover-Top, Rear.
10. Mount the Tray-Lower.
11. Mount the Cover-Jogging.

## Encoder Assembly Removal

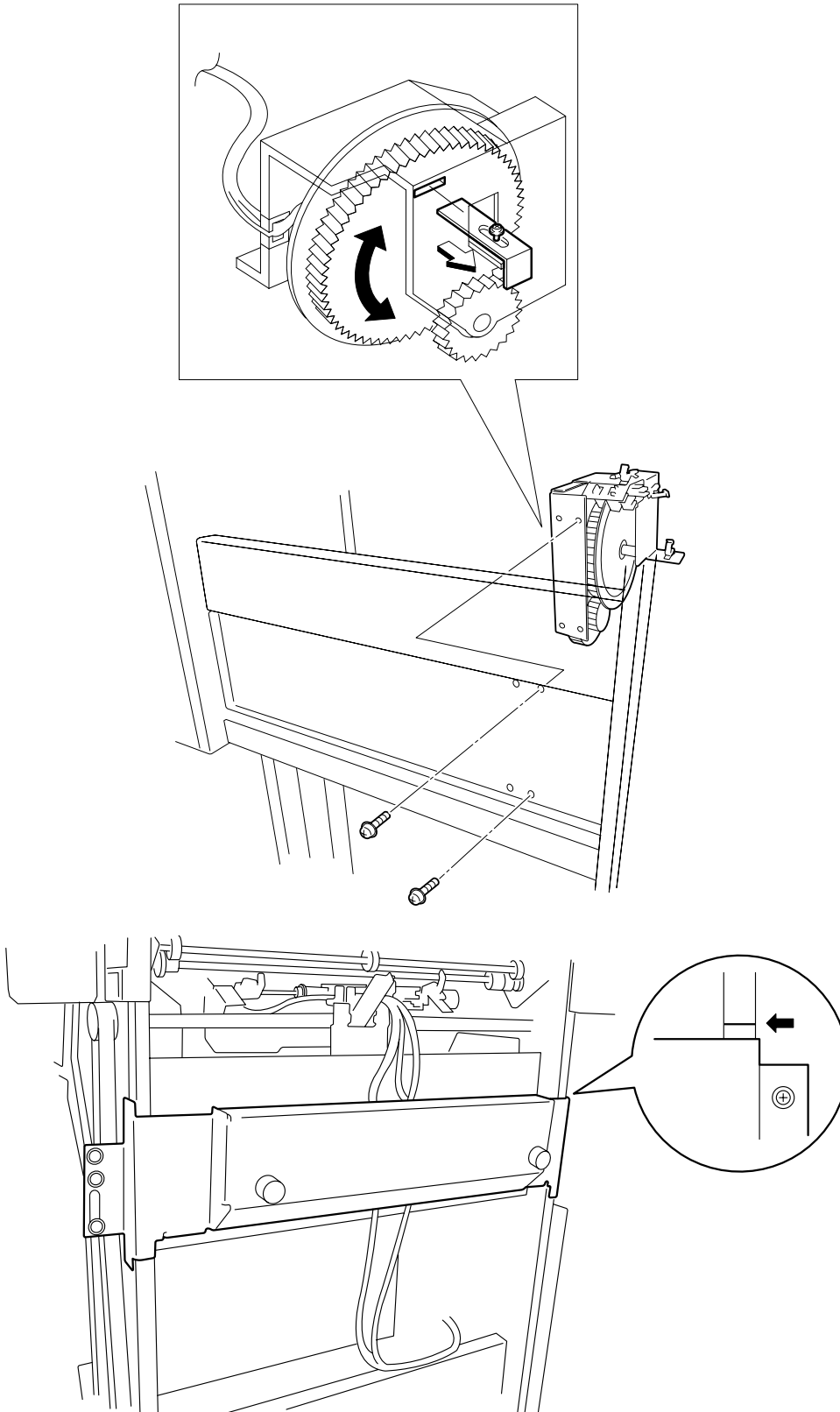

## 4025-Finisher

### Removal

1. Remove the Cover-Jogging.
2. Remove the Tray-Lower.
3. Remove the Cover-Top, Front and Cover-Top, Rear.
4. Remove the Cover-Rear.
5. Remove the Cover-Open, Front, Cover-Front and Kit Stud Cover.
6. Remove the Kit Bearing.
7. Remove the Right Cover.
8. Remove the Latch Assembly and Switch Docking.
9. Remove the Bottle Assembly-Dust.
10. Remove the Inner Cover.
11. Remove the Right Cover.
12. Remove the Drive Assembly-ELEV and Motor Assembly-MD11.
13. Unplug the connector (CN 11) of the Harness DC from the Motor Assembly-MD11.
14. Remove two screws that secure to the Finisher from the Encorder Assembly, and remove the Encorder Assembly.

### Replacement

1. Loosen the screw that secures the bracket jig of the Encorder Assembly, align a rectangular hole in large gear with the bracket position, insert the bracket into rectangular hole, and secure the bracket with the screw.

**Note:** In the following steps, simultaneous two operations need two persons.

2. With the bottom of Bracket aligned with the markings on both sides of Finisher (bottom of the upper stay of the Finisher), align the Encorder Assembly with its mounting position in the Finisher, and then secure with two screws.
3. Plug the connector (CN 11) of the Harness DC to the Motor Assembly-MD11.
4. Loosen the screw that secures the bracket jig of the Encorder Assembly, pull the bracket out of the rectangular hole in large gear, and secure the bracket with the screw.
5. Mount the Drive Assembly-ELEV and Motor Assembly-MD11.
6. Mount the Right Cover.
7. Mount the Kit Bearing.
8. Mount the Inner Cover.
9. Mount the Bottle Assembly-Dust.
10. Mount the Latch Assembly and Switch Docking.
11. Mount the Right Cover.
12. Mount the Cover-Open, Front, Cover-Front and Kit Stud Cover.
13. Mount the Cover-Rear.
14. Mount the Cover-Top, Front and Cover-Top, Rear.
15. Mount the Tray-Lower.
16. Mount the Cover-Jogging.

## Power Supply Removal

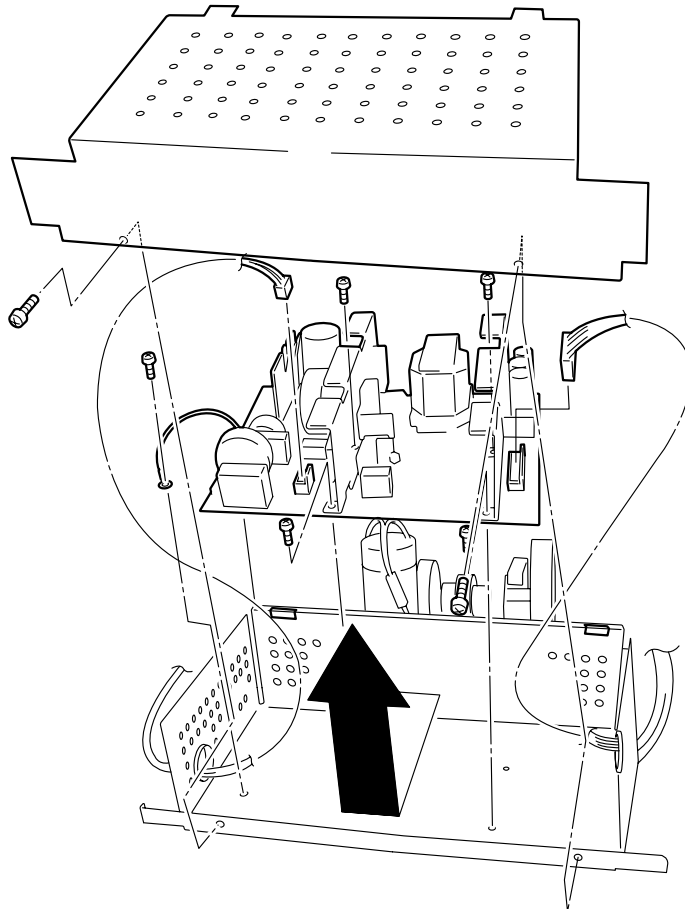
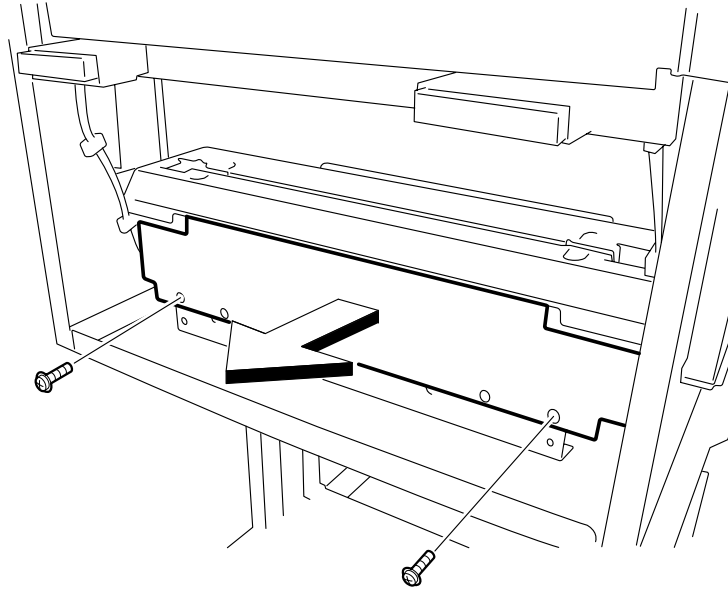

### Removal

1. Remove two screws that secure to the Latch Assembly from the Cover Lower Left.
2. Remove two screws that secure to the Finisher from the Cover Lower Left, and remove the Cover Lower Left.
3. Remove two screws that secure the LVPS Cover Lower to the Finisher, and pull out the LVPS Cover Lower together with the LVPS Cover Upper and Power Supply toward the front.
4. Remove two screws that secure to the LVPS Cover Lower from the LVPS Cover Upper, and remove the LVPS Cover Upper.
5. Remove the screw that secures the grounding wire of the Power Supply to the LVPS Cover Lower. (Figure 2)
6. Unplug the connector (P/J CN3) of the Harness Motor from the Power Supply. (Figure 2)
7. Unplug the connector (P/J CN1) of the Harness Motor from the Power Supply. (Figure 2)
8. Remove four screws that secure to the LVPS Cover Lower from the Power Supply, and remove the Power Supply. (Figure 2)

### Replacement

1. Align the Power Supply with the mounting position in the LVPS Cover Lower, and secure it with four screws. (Figure 2)
2. Plug the connector (P/J CN1) of the Harness Motor to the Power Supply. (Figure 2)
3. Plug the connector (P/J CN3) of the Harness Motor to the Power Supply. (Figure 2)
4. Secure the grounding wire of the Power Supply to the LVPS Cover Lower with a screw. (Figure 2)
5. Set in position so that the convex of the LVPS Cover Upper is met with the hole in the LVPS Cover Lower, and secure them with two screws. (Figure 1)
6. Align the LVPS Cover Lower together with the LVPS Cover Upper and the Power Supply, with the mounting position in the Finisher, and secure it with two screws.
7. Align the Cover Lower Left with the mounting position in the Finisher, and secure it with two screws.
8. Secure the Cover Lower Left to the Latch Assembly with the two screws.

## PWB Assembly-Main Removal

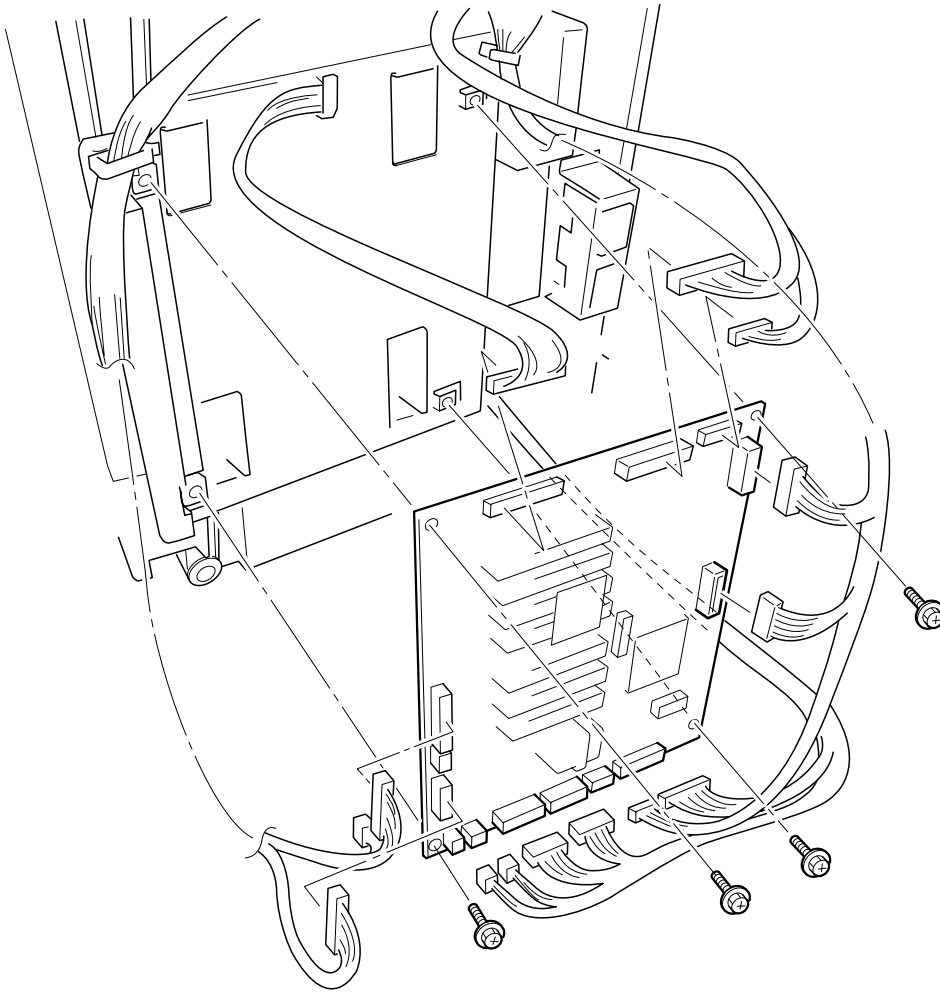



### Removal

1. Remove the Cover-Jogging.
2. Remove the Cover-Top, Rear.
3. Remove the Cover-Rear.
4. Unplug the connector (P/J 1A) of the Harness DC from the PWB Assembly-Main.
5. Unplug the connector (P/J 2A) of the Harness DC from the PWB Assembly-Main.
6. Unplug the connector (P/J 3A) of the Harness Middle Stapler from the PWB Assembly-Main.
7. Unplug the connector (P/J 4A) of the Harness Motor from the PWB Assembly-Main.
8. Unplug the connector (P/J 6A) of the Harness Motor from the PWB Assembly-Main.
9. Unplug the connector (P/J 7A) of the Harness DC from the PWB Assembly-Main.
10. Unplug the connector (P/J 9A) of the Harness Middle Stapler from the PWB Assembly-Main.
11. Unplug the connector (P/J 10A) of the Harness Sensor from the PWB Assembly-Main.
12. Unplug the connector (P/J 11A) of the Harness H-Try from the PWB Assembly-Main.
13. Unplug the connector (P/J 12A) of the Harness Sensor from the PWB Assembly-Main.
14. Unplug the connector (P/J 13A) of the Harness Middle 1 from the PWB Assembly-Main.
15. Unplug the connector (P/J 16A) of the Harness I/F from the PWB Assembly-Main.
16. Unplug the connector (P/J 18A) of the Harness Face Up from the PWB Assembly-Main.
17. Remove four screws that secure to the Finisher from the PWB Assembly-Mainland and remove the PWB Assembly-Main.

### Replacement

1. Insert four screws into four holes in the PWB Assembly-Main, and then insert four spacers from the back.
2. Align the PWB Assembly-Main, together with four screws and spacers, with the mounting position in the Finisher, and secure them with four screws.
3. Plug the connector (P/J 1A) of the Harness DC to the PWB Assembly-Main.
4. Plug the connector (P/J 3A) of the Harness Middle Stapler to the PWB Assembly-Main.
5. Plug the connector (P/J 4A) of the Harness Motor to the PWB Assembly-Main.
6. Plug the connector (P/J 6A) of the Harness Motor to the PWB Assembly-Main.
7. Plug the connector (P/J 7A) of the Harness DC to the PWB Assembly-Main.
8. Plug the connector (P/J 9A) of the Harness Middle Stapler to the PWB Assembly-Main.
9. Plug the connector (P/J 10A) of the Harness Sensor to the PWB Assembly-Main.
10. Plug the connector (P/J 11A) of the Harness H-Try to the PWB Assembly-Main.
11. Plug the connector (P/J 12A) of the Harness Sensor to the PWB Assembly-Main.
12. Plug the connector (P/J 13A) of the Harness Middle 1 to the PWB Assembly-Main.
13. Plug the connector (P/J 16A) of the Harness I/F to the PWB Assembly-Main.
14. Plug the connector (P/J 18A) of the Harness Face Up to the PWB Assembly-Main.
15. Mount the Cover-Rear.
16. Mount the Cover-Top, Rear.
17. Mount the Cover-Jogging.

## Port Harness Assembly Removal

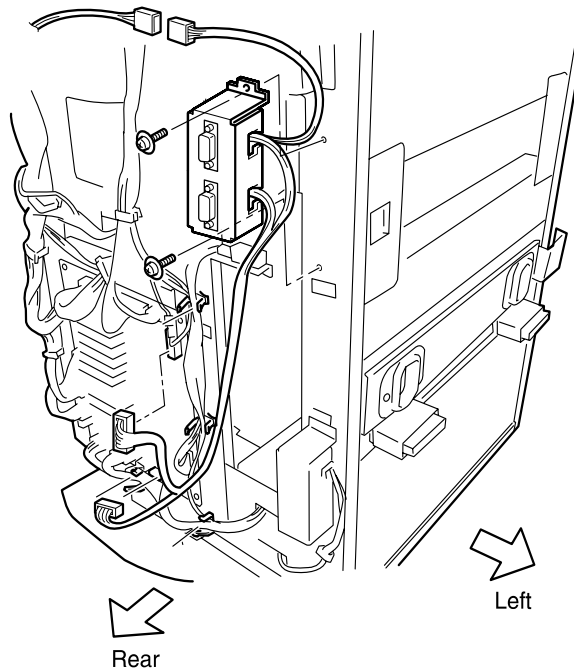

### Removal

1. Remove the Cover-Jogging.
2. Remove the Cover-Top, Rear.
3. Remove the Cover-Rear.
4. Release two Clamp on the PWB Chassis to release the harness.
5. Unplug the connector (P/J 11A) of the Harness H-Tra from the PWB Assembly-Main.
6. Unplug the connector (P/J 16) of the Harness H-Tra from the PWB Assembly-Main.
7. Unplug the connector (CN 17) of the Harness H-Tra from the Harness Motor.
8. Remove two screws that secure to the Finisher from the Harness H-Tra, and remove the Port harness assembly.

### Replacement

1. Align the with the mounting position in the Finisher, and secure it with two screws.
2. Plug the connector (CN 17) of the Harness H-Tra to the Harness Motor.
3. Plug the connector (P/J 16) of the Harness H-Tra to the PWB Assembly-Main.
4. Plug the connector (P/J 11A) of the Harness H-Tra to the PWB Assembly-Main.
5. Bundle the harness with two Clamp on the PWB Chassis.
6. Mount the Cover-Rear.
7. Mount the Cover-Top, Rear.
8. Mount the Cover-Jogging.

### No Paper Sensor Assembly Removal

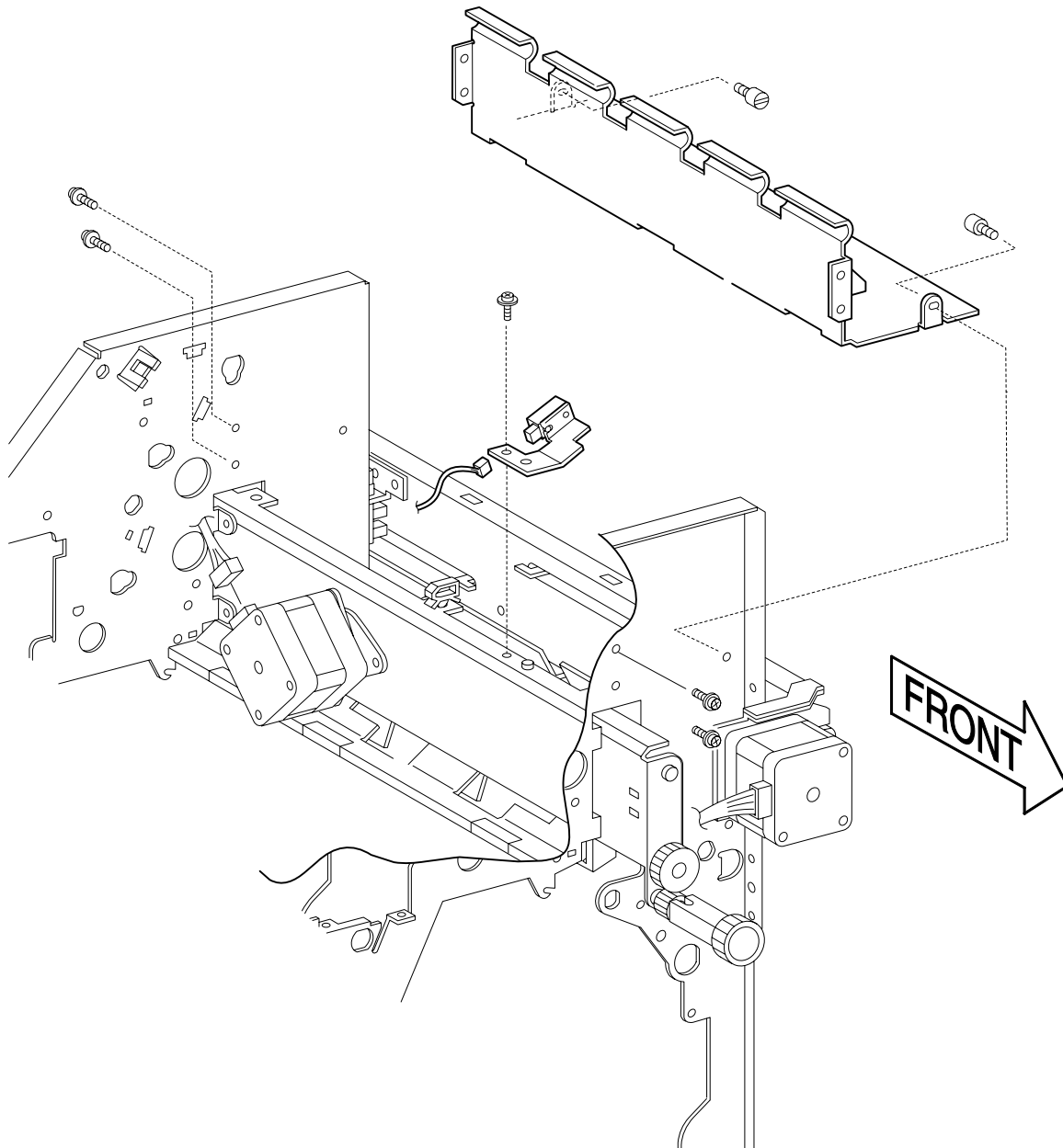

## 4025-Finisher

### Removal

1. Remove the Cover-Top, Front and Cover-Top, Rear.
2. Remove the screws on the front and rear that secure to the frame of the Finisher from the L Cover.
3. Remove screws respectively on the front and rear that secure to the L Cover from the frame of the Finisher, and remove the L Cover from the Finisher.
4. Unplug the connector (P/J 29) of the Harness Face Up from the Sensor Assembly.
5. Remove the screw that secures to the Shift Unit from the Sensor Assembly, and remove the Sensor Assembly.

### Replacement

1. Align the Sensor Assembly with the mounting position on the Shift Unit, and secure it with a screw.
2. Plug the connector (P/J 29) of the Harness Face Up to the Sensor Assembly.
3. Align the L Cover with the mounting position in the Finisher, and secure the front and rear with two screws respectively.
4. Secure the front and rear of the L Cover with screws.
5. Mount the Cover-Top, Front and Cover-Top, Rear.

## Face Up Tray Removal

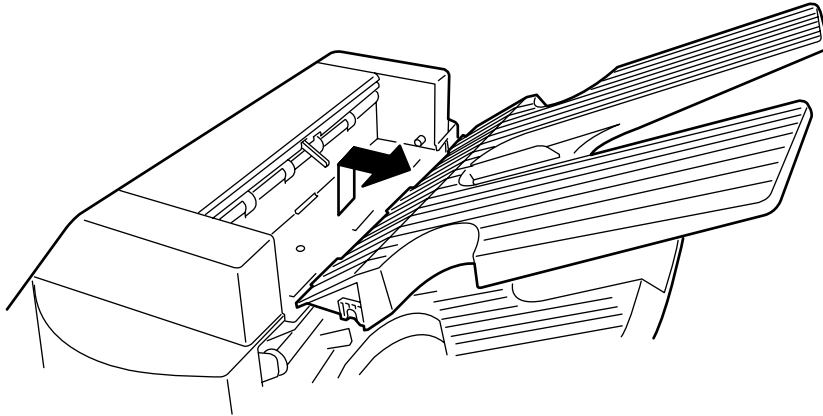

### Removal

Lift the leading end of the Face Up Tray a little, and pull it off toward the right.

### Replacement

Insert three bosses of the Face Up Tray into the holes in the L Cover, and mount the Face Up Tray.

## Top Cover Interlock Switch Removal

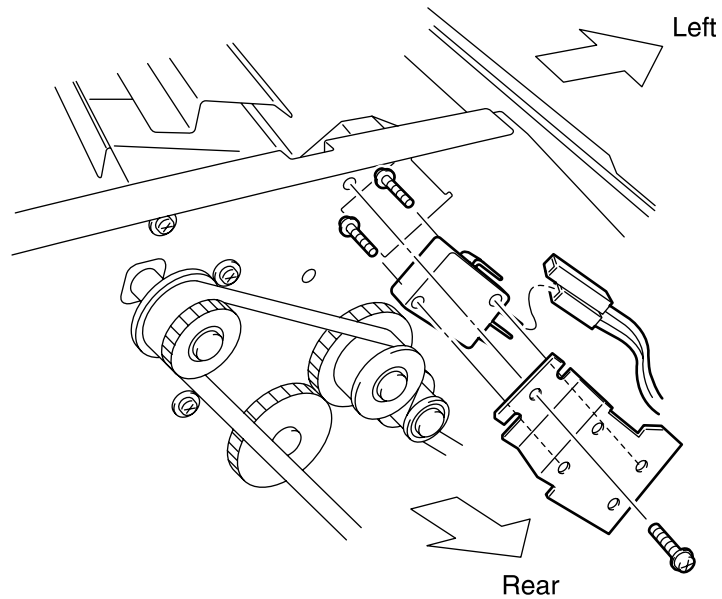

### Removal

1. Remove the Cover-Top, Front and Cover-Top, Rear.
2. Unplug the connector (S 3-1) of the Harness Motor from the Top Cover Interlock Switch.
3. Remove the screw that secures to the frame of the Finisher from the Top Cover Interlock Switch, and remove the Top Cover Interlock Switch.

### Replacement

1. Align the Top Cover Interlock Switch with the mounting position in the frame on the rear of the Finisher, and secure it with a screw.
2. Plug the connector (S 3-1) of the Harness Motor to the Top Cover Interlock Switch.
3. Mount the Cover-Top, Front and Cover-Top, Rear.

## Gate Solenoid Removal

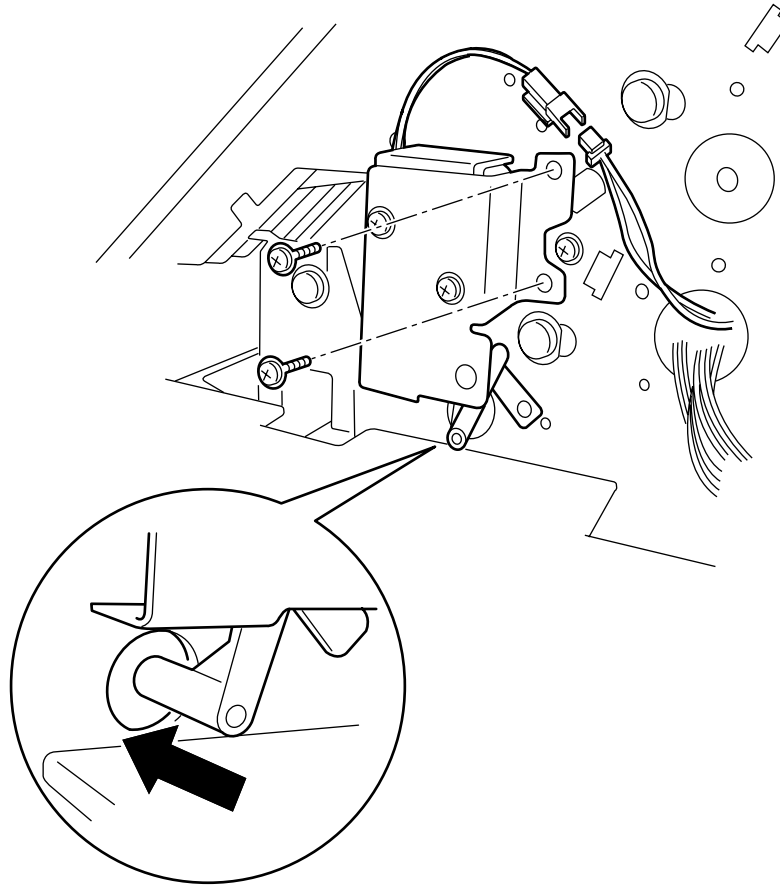

### Removal

1. Remove the Cover-Top, Front and Cover-Top, Rear.
2. Unplug the connector (CN 16) of the Harness Motor from the Gate Solenoid.
3. Remove two screws that secure to the frame on the front of the Finisher from the Gate Solenoid, and remove the Gate Solenoid.

### Replacement

1. Align the Gate Solenoid with the mounting position so that the actuator of the Gate Solenoid comes to the right of the actuator of the Gate Solenoid, and then secure it with two screws.
2. Plug the connector (CN 16) of the Harness Motor to the Gate Solenoid.
3. Mount the Cover-Top, Front and Cover-Top, Rear.



## Full Stack Sensor Assembly Removal

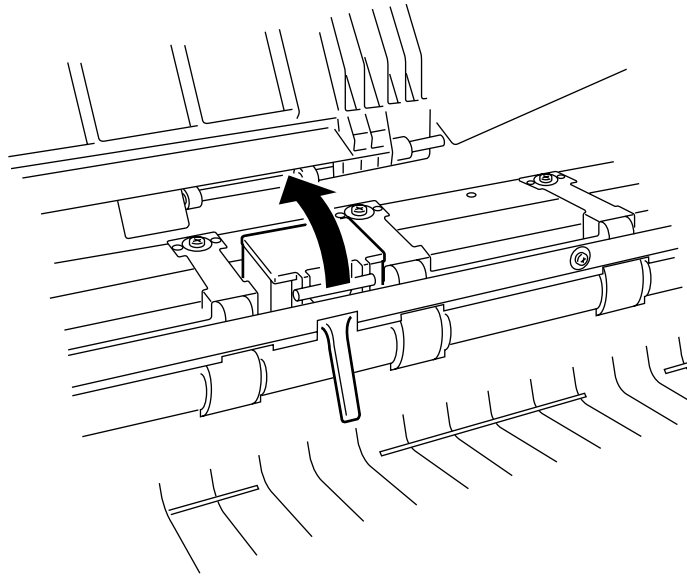

### Removal

1. Open the Top Center Cover Assembly.
2. Unplug the connector (CN 37) of the Harness Face Up from the Full Stack Sensor Assembly.
3. Release the harness of the Full Stack Sensor Assembly from the CLamp.
4. Pushing the upper right of the Full Stack Sensor Assembly toward the left with your finger, lift it, and remove the Full Stack Sensor Assembly.

### Replacement

1. Insert the actuator of the Full Stack Sensor Assembly into the hole in the Upper Guide.
2. Insert the boss on the left of the Full Stack Sensor Assembly into the hole in the Upper Guide, lower the Full Stack Sensor Assembly while pushing the upper right of the Full Stack Sensor Assembly toward the left with your finger.
3. Bundle the harness of the Full Stack Sensor Assembly with the Clamp.
4. Plug the connector (CN 37) of the Harness Face Up to the Full Stack Sensor Assembly.
5. Close the Top Center Cover Assembly.

## Pinch Roll Removal

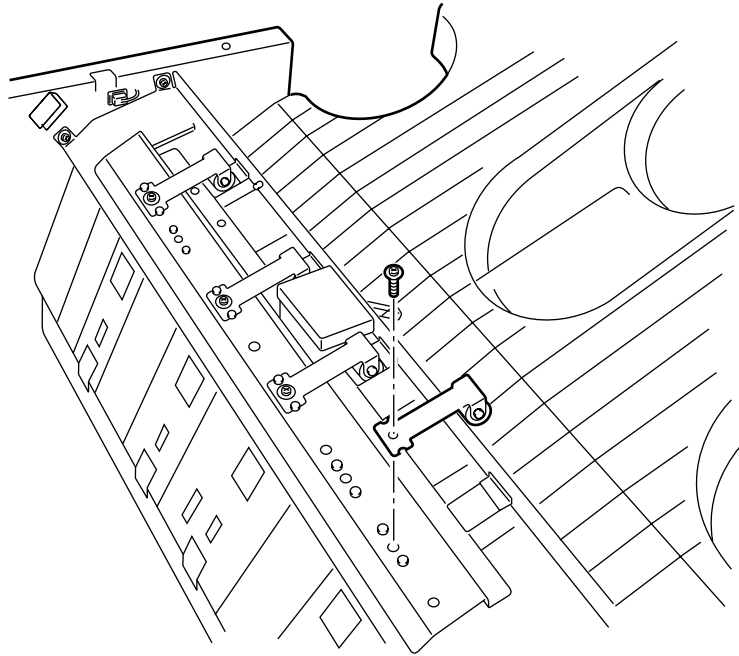

### Removal

1. Open the Top Center Cover Assembly.
2. Remove the screw that secures to the Upper Guide from the Pinch Roll, and remove the Pinch Roll.

### Replacement

1. Align the Pinch Roll, with the mounting positions in the Upper Guide. and secure them with a screw.
2. Repeat the above steps until you have mounted all the Pinch Roll.
3. Close the Top Center Cover Assembly.

## Exit Sensor Removal

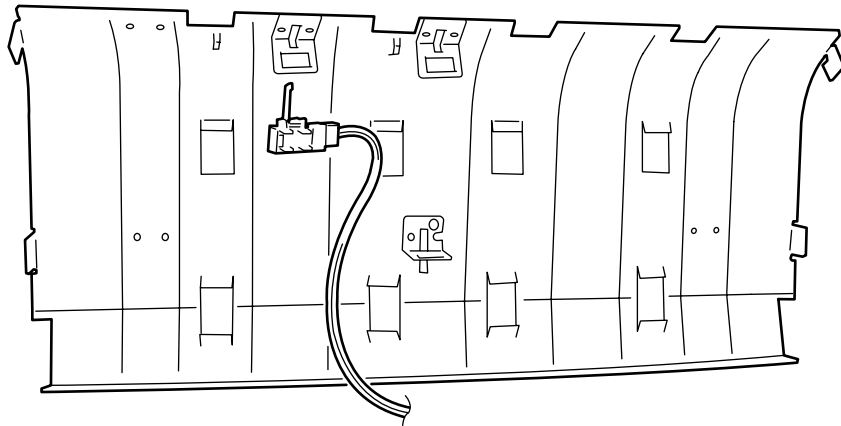
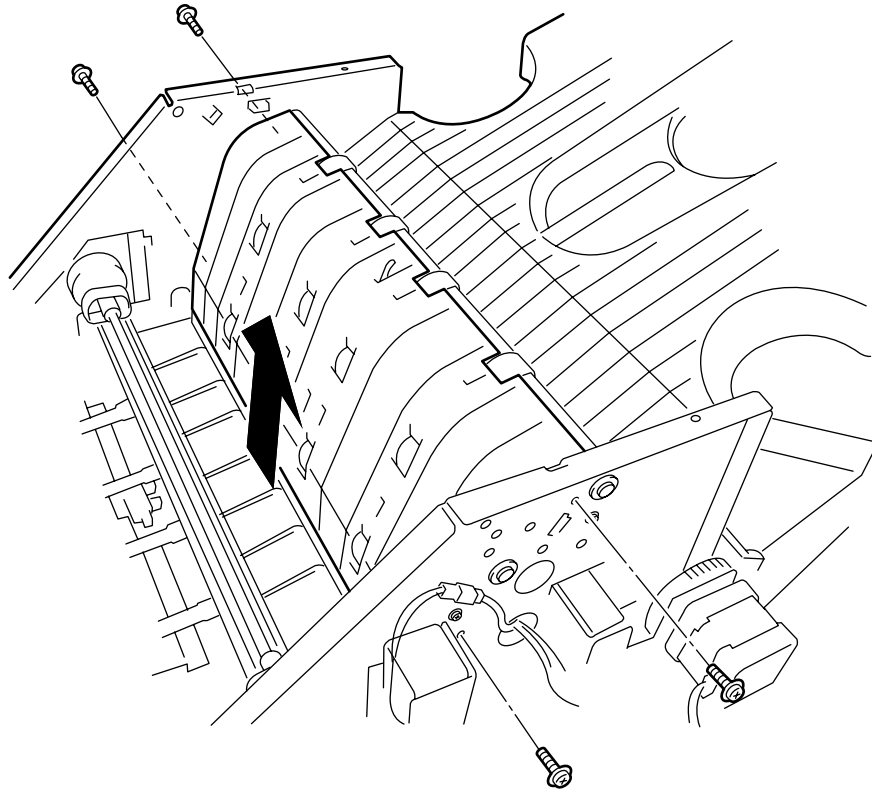

## 4025-Finisher

### Removal

1. Remove the Sensor Assembly.
2. Remove the Exit Assembly.
3. Unplug the connector (CN 38) of the Harness Face Up from the Exit Sensor.
4. Disengage four hooks of the Exit Sensor, and remove the Exit Sensor from the Finisher.

### Replacement

1. From the right of the Finisher, align the Exit Sensor with the mounting position in the Lower Guide, and secure it.
2. Plug the connector (CN 38) of the Harness Face Up to the Exit Sensor.
3. Mount the Exit Assembly.
4. Mount the Sensor Assembly.

## Exit Assembly Removal

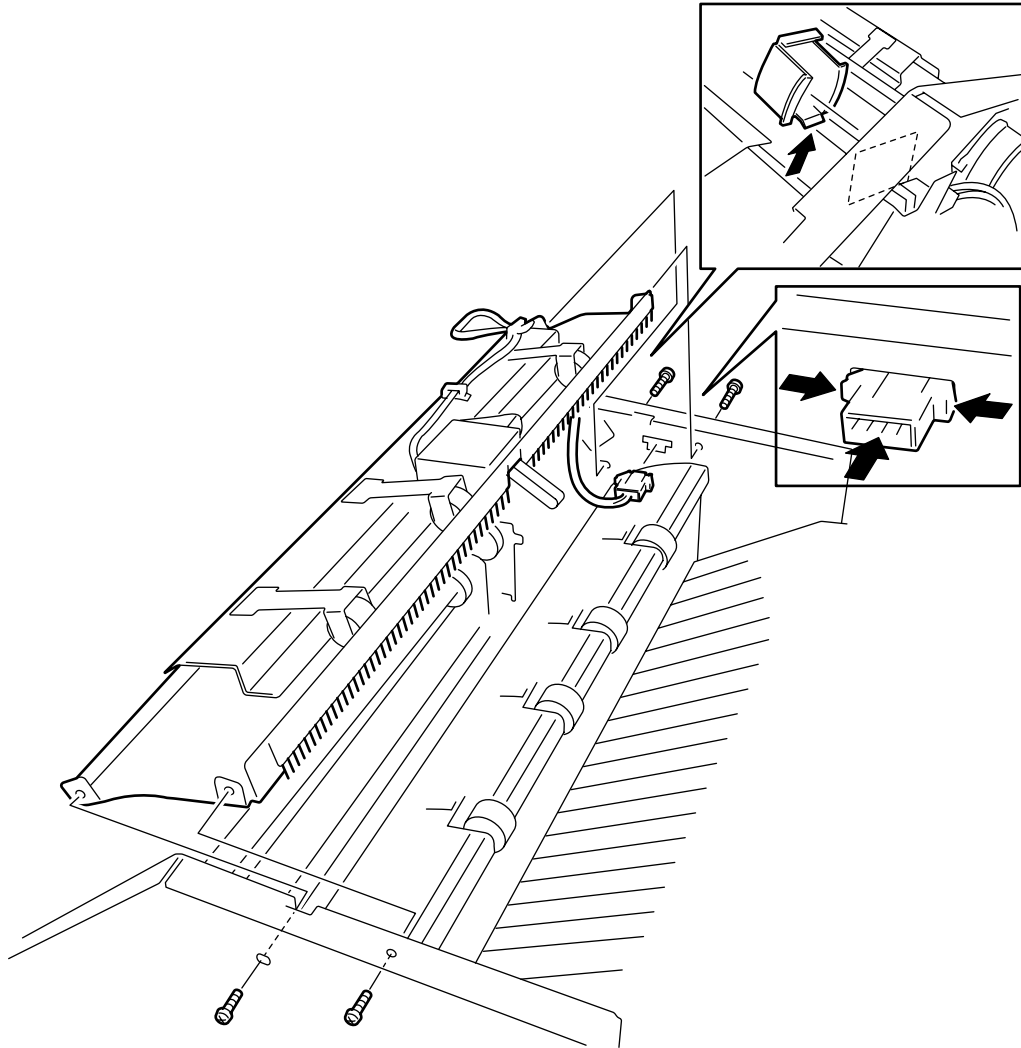

## 4025-Finisher

### Removal

1. Open the Top Center Cover Assembly.
2. Unplug the connector (CN 37) of the Harness Face Up from the Full Stack Sensor Assembly.
3. Disengage two hooks of the connector (CN 37), and pull the connector (CN 37) off from the Finisher Frame.
4. From the rear, disengage two hooks of the Switch Cap, and push the Switch Cap out of the Finisher.
5. Remove two screws respectively on the front and rear that secure the Exit Assembly to the frame.

### Replacement

1. Align the Exit Assembly with the mounting position in the Finisher, and secure it with two screws respectively on the front and rear.
2. Insert the Switch Cap into the hole in the rear frame, and secure it with two hooks.
3. Insert the connector (CN 37) into the hole in the rear frame, and secure it with two hooks.
4. Plug the connector (CN 37) of the Harness Face Up to the Full Stack Sensor Assembly.
5. Close the Top Center Cover Assembly.

## Upper Roll and Roll Transport Removal

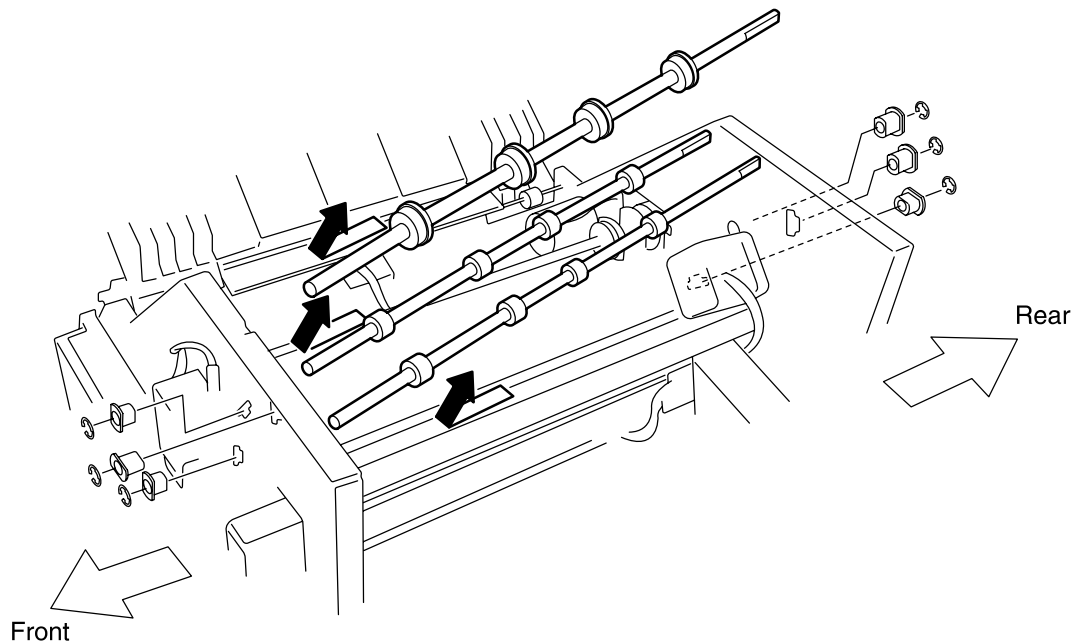

### Removal

1. Remove the Sensor Assembly.
2. Remove the Cover-Top, Front and Cover-Top, Rear.
3. Remove the Exit Assembly.
4. Remove the Exit Sensor.
5. Remove the Gear Kit.
6. Remove the front E-ring that secures the Upper Roll to the Finisher.
7. Remove two E-rings on the front that secure the upper and lower Roll Transport to the Finisher.
8. Remove two Bearing that secure the Upper Roll to the front and rear frames of the Finisher.
9. Remove four Bearings that secure the upper and lower Roll Transport to the front and rear frames of the Finisher.
10. Slide the Upper Roll toward the front until the rear shaft is removed from the frame, and pull off the rear shaft in diagonal upward direction.
11. Slide the upper and lower Roll Transport toward the front until the rear shafts are removed from the frame, and pull off the rear shafts in diagonal upward direction.

### Replacement

1. Insert the upper and lower Roll Transport into respective shaft holes in the front frame of the Finisher, and insert the rear shafts into respective holes in the rear frame of the Finisher.
2. Insert four Bearings into the rear and front shafts of the upper and lower Roll Transport, and align the Roll Transport with the mounting position.
3. Secure the front shafts of the upper and lower Roll Transport with an E-ring.
4. Insert the Upper Roll into the shaft hole in the front frame of the Finisher, and insert the rear shaft into the hole in the rear frame of the Finisher.
5. Insert the Bearing into the front and rear shafts of the Upper Roll, align the Upper Roll with the mounting position.
6. Secure the shaft on the front of the Upper Roll with an E-ring.
7. Mount the Gear Kit.
8. Remove the Exit Sensor.
9. Mount the Exit Assembly.
10. Mount the Cover-Top, Front and Cover-Top, Rear.
11. Mount the Sensor Assembly.



## Stepping Motor, Upper Tray Removal

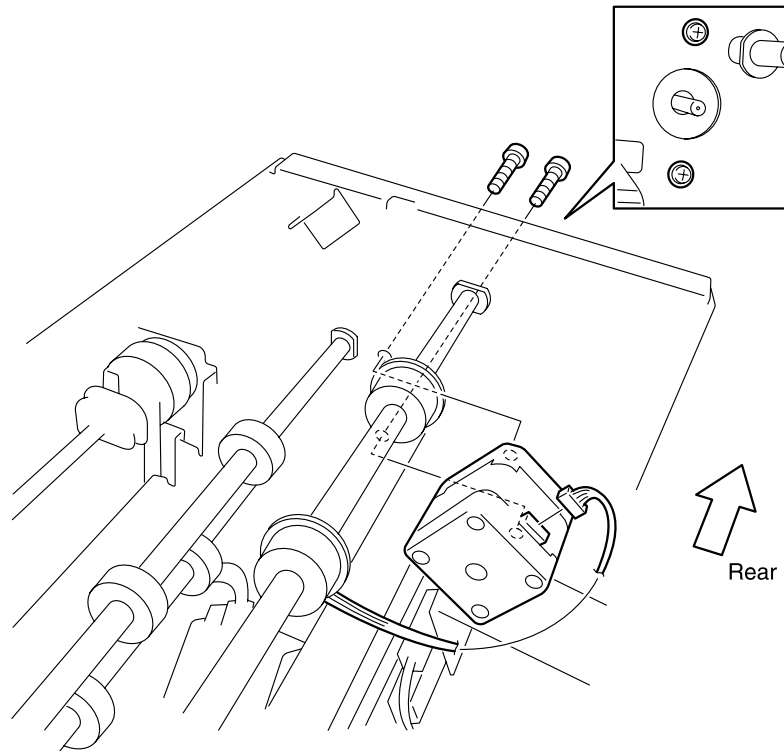

### Removal

1. Remove the Sensor Assembly.
2. Remove the Cover-Top, Front and Cover-Top, Rear.
3. Remove the Exit Assembly.
4. Remove the Exit Sensor.
5. Remove the Gear Kit.
6. Unplug the connector (CN 12) of the Harness Motor from the Stepping Motor, Upper Tray.
7. Remove two screws that secure the Stepping Motor, Upper Tray to the Finisher, and remove the Stepping Motor, Upper Tray.

### Replacement

1. Align the Stepping Motor, Upper Tray with the mounting position in the Finisher, and secure them with two screws.
2. Plug the connector (CN 12) of the Harness Motor to the Stepping Motor, Upper Tray.
3. Mount the Gear Kit.
4. Mount the Exit Sensor.
5. Mount the Exit Assembly.
6. Mount the Cover-Top, Front and Cover-Top, Rear.
7. Mount the Sensor Assembly.

## Gear Kit Removal

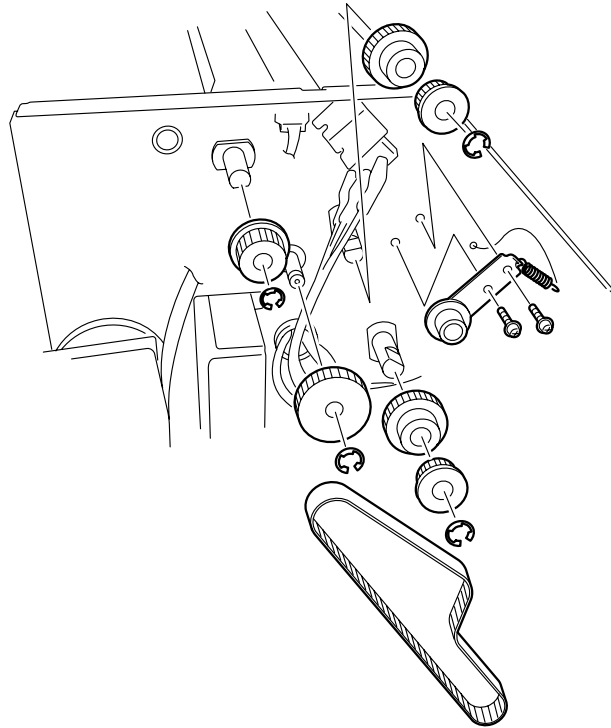

## Removal

1. Remove the Cover-Top, Front and Cover-Top, Rear.
2. Disengage the hook (long hook) that secures the Tension Spring to the frame.
3. Remove two screws that secure to the Finisher from the Tension Bracket, and remove the Tension Bracket together with the Tension Roll and Tension Spring.
4. Release the Belt from the Pulley Small, and remove the Belt.
5. Remove the E-ring that secures the Pulley Small to the shaft of the Upper Roll, and remove the Pulley Small.
6. Remove the E-rings that secure the Pulley Large and Pulley Small to the shafts of upper and lower Roll Transport, and remove the Pulley Large.
7. Remove the E-ring that secures the Pulley Drive to the shaft of the Stepping Motor, and remove the Pulley Drive.

## Replacement

1. Insert the Pulley Drive into the shaft of the Stepping Motor, and secure it with an E-ring.
2. Insert the Pulley Large and Pulley Small into the rear shafts of upper and lower Roll Transport, and secure them with an E-ring.
3. Insert the Pulley Small into the shaft on the rear of the Upper Roll, and secure it with an E-ring.
4. Secure the Pulley Small, and the two Roll Transports, to the Upper Roll.
5. Align the Tension Bracket, together with the Tension Roll and Tension Spring with the mounting position, and secure them tentatively with two screws.
6. Engage the hook (long hook) of the Tension Spring to the hole in the frame of the Finisher.
7. Position the tension roller to the extent that the Belt is not loose, and tighten two screws tentatively.
8. Mount the Cover-Top, Front and Cover-Top, Rear.

## 4025-Finisher

---

## 5. Connectors

Use the table and maps in this section to locate specific P/J connectors within the printer.

To find the location of a P/J:

1. Locate the P/J connector number in the first column of the table.
2. Locate the corresponding map and location number, such as M2-5, in the second column.
3. Go to the map (M2) number and locate item number (5).

## Location Table

P/J	Map & Number	Connected to...	Other end connected to...
1	M5-5	Sensor	P/J10AA PWB CHASSIS
1A	M5-16	PWB CHASSIS	2P Power Supply
1C-R	M4-5	Sensor Tray Height Front	P/J12A PWB CHASSIS
1C-L	M4-3	Sensor Tray Height Rear	P/J12A PWB CHASSIS
1D	M4-10	CN9 Motor Assembly CN10 Stapler Assembly P10 Sensor P12 Sensor Assembly Swing P11 Sensor Assembly Swing	P/J9A PWB CHASSIS
1P	M4-13	Power Supply	AC Power
2	M2-6	Sensor	P/J10AA PWB CHASSIS
2A	M5-15	PWB CHASSIS	S1-1 Switch Docking S2-1 Switch Cover Front
2D	M4-9	CN9 Motor Assembly Swing CN10 Stapler Assembly P10 Sensor P12 Sensor Assembly Swing P11 Sensor Assembly Swing	P/J9A PWB CHASSIS
2P	M4-12	Power Supply	P/J1A PWB CHASSIS
3A	M5-19	PWB CHASSIS	S3-1/S3-2 Top Cover interlock Switch CN43 Exit Roll Sensor
4A 4	M5-21	PWB CHASSIS	CN1 Transport Motor Assembly CN8 Motor Assembly MP-8 CN17 to CN31 CN18 Puncher
5A 5	M5-20	PWB CHASSIS	CN6 Stepping Motor CN7 Stepping Motor
6A 6	M5-22	PWB CHASSIS	CN2 Motor Assembly MP-2 CN4 Motor Assembly MP-4 CN12 Stepping Motor CN5 Motor MP-5 CN3 Motor CN16 Gate Solenoid
7	M4-4	Sensor	P/J10AB PWB CHASSIS
7A	M5-17	PWB CHASSIS	CN11 Motor Assembly MD-1

4025-Finisher

<b>P/J</b>	<b>Map &amp; Number</b>	<b>Connected to...</b>	<b>Other end connected to...</b>
8	M2-11	Sensor	P/J10AB PWB CHASSIS
9	M2-9	Sensor	P/J10AB PWB CHASSIS
9A	M5-1	PWB CHASSIS	P/J13 No Paper Sensor Stapler CN9 Motor Assembly Swing CN10 Stapler Assembly P/J10 Sensor P/J12 Sensor Assembly Swing P/J11 Sensor Assembly Swing
10AA	M5-2	PWB CHASSIS	P/J1 Sensor P/J2 Sensor P/J5 Sensor
10AB 10	M5-2	PWB CHASSIS	P/J6 Sensor P/J7 Sensor P/J8 Sensor P/J9 Sensor
11AA 11	M5-7	PWB CHASSIS	P/J256M Solenoid Assembly P/J263 Sensor P/J275M Sensor P/J259 Sensor P/J260 Sensor
11AB 11	M5-7	PWB CHASSIS	P/J18 Sensor Dust Assembly
12A 12	M5-3	PWB CHASSIS	P/J1C-L Sensor Tray Height Front P/J1C-R Sensor Tray Height Rear
13A 13 14	M5-13	PWB CHASSIS	P/J15 Encoder Assembly P/J16 Encoder Assembly P/J17 Encoder Assembly P/J24 Photo Sensor P/J14 No Paper Sensor Tray Lower
16A	M5-14	PWB CHASSIS	CN30 Port Harness Assembly
18	M2-3	Sensor Dust Assembly	P/J18 PWB CHASSIS
18A	M5-11	PWB CHASSIS	P/J29 No Paper Sensor P/J37 Full Stack Sensor P/J38 Exit Sensor
19A	M5-18	PWB CHASSIS	CN41 Stack Arm Assembly
S1-1	M2-2	Switch Docking	P/J2A PWB CHASSIS
S2-1	M2-1	Switch Cover Front	P/J2A PWB CHASSIS
CN1	M2-4	Transport Motor Assembly	P/J4A PWB CHASSIS

## 4025-Finisher

<b>P/J</b>	<b>Map &amp; Number</b>	<b>Connected to...</b>	<b>Other end connected to...</b>
CN2	M4-1	Motor Assembly-MP2	P/J6A PWB CHASSIS
CN3	M3-8	Motor	P/J6A PWB CHASSIS
CN4	M3-1	Motor Assembly-MP4	P/J6A PWB CHASSIS
CN5	M4-2	Motor-MP5	P/J6A PWB CHASSIS
CN6	M2-8	Stepping Motor	P/J5A PWB CHASSIS
CN7	M2-12	Stepping Motor	P/J5A PWB CHASSIS
CN8	M4-14	Motor Assembly-MP8	P/J4A PWB CHASSIS
CN9	M4-6	Motor Assembly Swing	P/J9A PWB CHASSIS
CN10	M4-15	Stapler Assembly	P/J9A PWB CHASSIS
CN11	M3-11	Motor Assembly-MD11	P/J7A PWB CHASSIS
CN16	M5-14	Buffer Solenoid	P/J17A Power Unit
CN17	M5-6	P256M Solenoid Assembly	P/J4A PWB CHASSIS
CN18	M2-7	Puncher	P/J4A PWB CHASSIS
10	M4-11	Sensor	P/J9A PWB CHASSIS
11	M4-7	Sensor Assembly Swing	P/J9A PWB CHASSIS
12	M4-8	Sensor Assembly Swing	P/J9A PWB CHASSIS
13	M3-6	No Paper Sensor Stapler	P/J9A PWB CHASSIS
14	M3-7	No Paper Sensor Tray Lower	P/J13A PWB CHASSIS
4	M2-10	Sensor	P/J10AA PWB CHASSIS
5	M3-5	Sensor	P/J10AA PWB CHASSIS
6	M3-2	Sensor	P/J10AB PWB CHASSIS
17	M3-12	Encoder Assembly	P/J13A PWB CHASSIS
CN21	M3-3	P5 Sensor	P/J10AA PWB CHASSIS
18	M2-3	Punch Dust Full Sensor	P/J11AA Power Unit
15	M3-9	Encoder Assembly	P/J13A PWB CHASSIS
16	M3-10	Encoder Assembly	P/J13A PWB CHASSIS
24	M3-13	Photo Sensor	P/J13A PWB CHASSIS
CN29	M3-12	P24 Photo Sensor	P/J13A PWB CHASSIS
CN30	M5-5	Printer	P/J16A PWB CHASSIS



## 4025-Finisher

<b>P/J</b>	<b>Map &amp; Number</b>	<b>Connected to...</b>	<b>Other end connected to...</b>
CN31	M5-4	P256M Solenoid Assembly P259 Sensor P260 Sensor P261 Sensor P263 Sensor P275M Sensor P259 Sensor P260 Sensor P279 Sensor	P/J11AA PWB CHASSIS P/J11AB PWB CHASSIS
CN39	M3-15	Encoder Assembly	P/J13A PWB CHASSIS
CN40	M3-16	P13 No Paper Sensor Stapler	P/J13A PWB CHASSIS
CN41	M3-17	Stack Arm Assembly	P/J19A PWB CHASSIS
CN42	M2-1	Swirh Docking Interlock	P/J2A PWB CHASSIS
CN43	M3-4	Exit Roll Sensor	P/J3A PWB CHASSIS
256M	M1-3	Solenoid Assembly	P/J11AA PWB CHASSIS
259	M1-5	Sensor	P/J11AA PWB CHASSIS
260	M1-1	Sensor	P/J11AA PWB CHASSIS
261	M1-2	Sensor	P/J11AA PWB CHASSIS
262	M1-8	P263 Sensor P275M Sensor	P/J11AA PWB CHASSIS
263	M1-4	Sensor	P/J11AA PWB CHASSIS
268	M1-7	P259 Sensor P260 Sensor	P/J11AA PWB CHASSIS
275M	M1-6	Sensor	P/J11AA PWB CHASSIS
279	M1-9	Sensor	P/J11AA PWB CHASSIS
CN12	M6-2	Stepping Motor	P/J6A PWB CHASSIS
S3-1, S3-2	M6-1	Top Cover Interlock Switch	P/J3A PWB CHASSIS
CN37	M6-3	P30 Full Stack Sensor Assembly	P/J18A PWB CHASSIS
CN38	M6-4	P31 Exit Sensor	P/J18A PWB CHASSIS
30	M6-5	Full Stack Sensor	P/J18A PWB CHASSIS
29	M6-6	No Paper Sensor	P/J18A PWB CHASSIS
CN16	M6-7	Gate Solenoid	P/J6A PWB CHASSIS

# Location Map 1

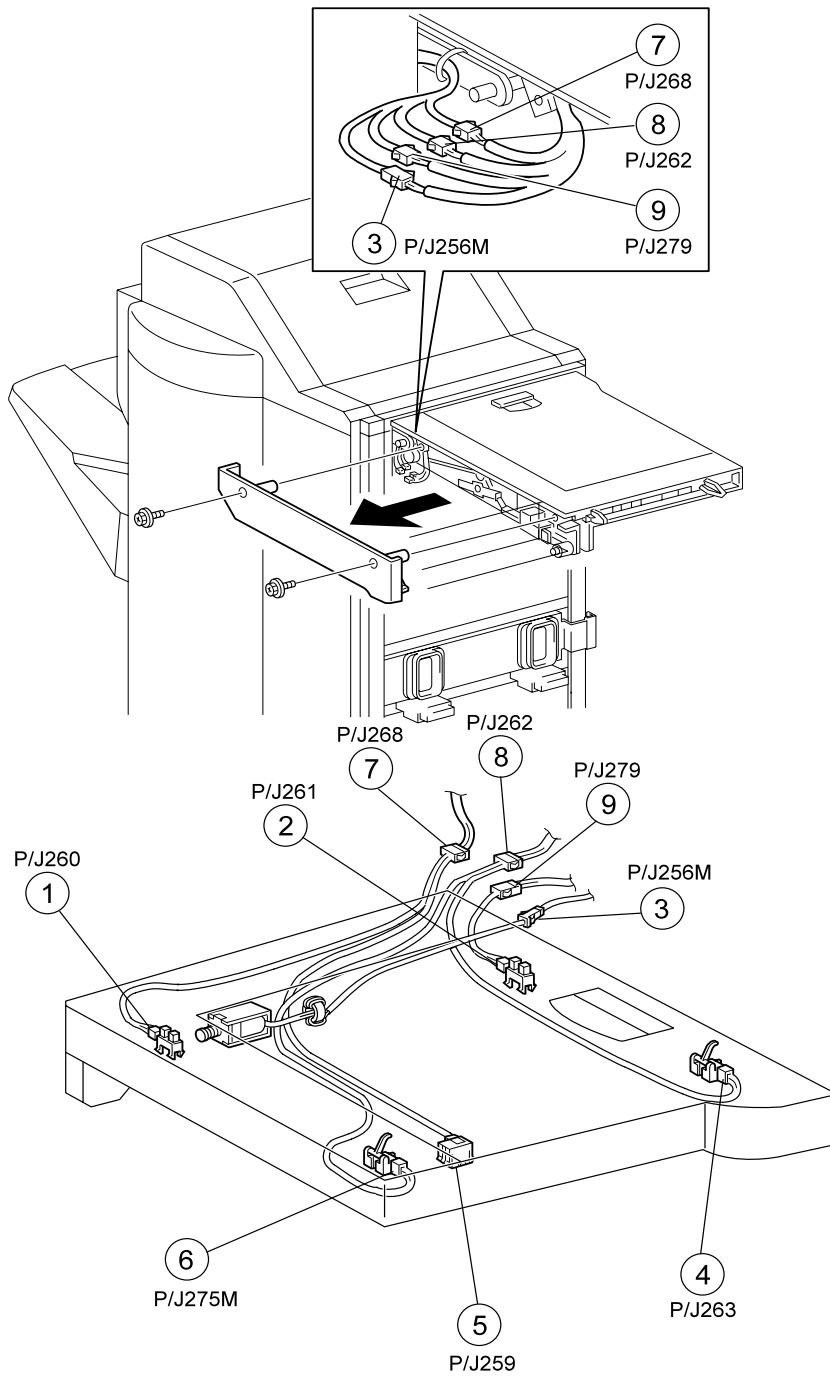

## Location Map 2

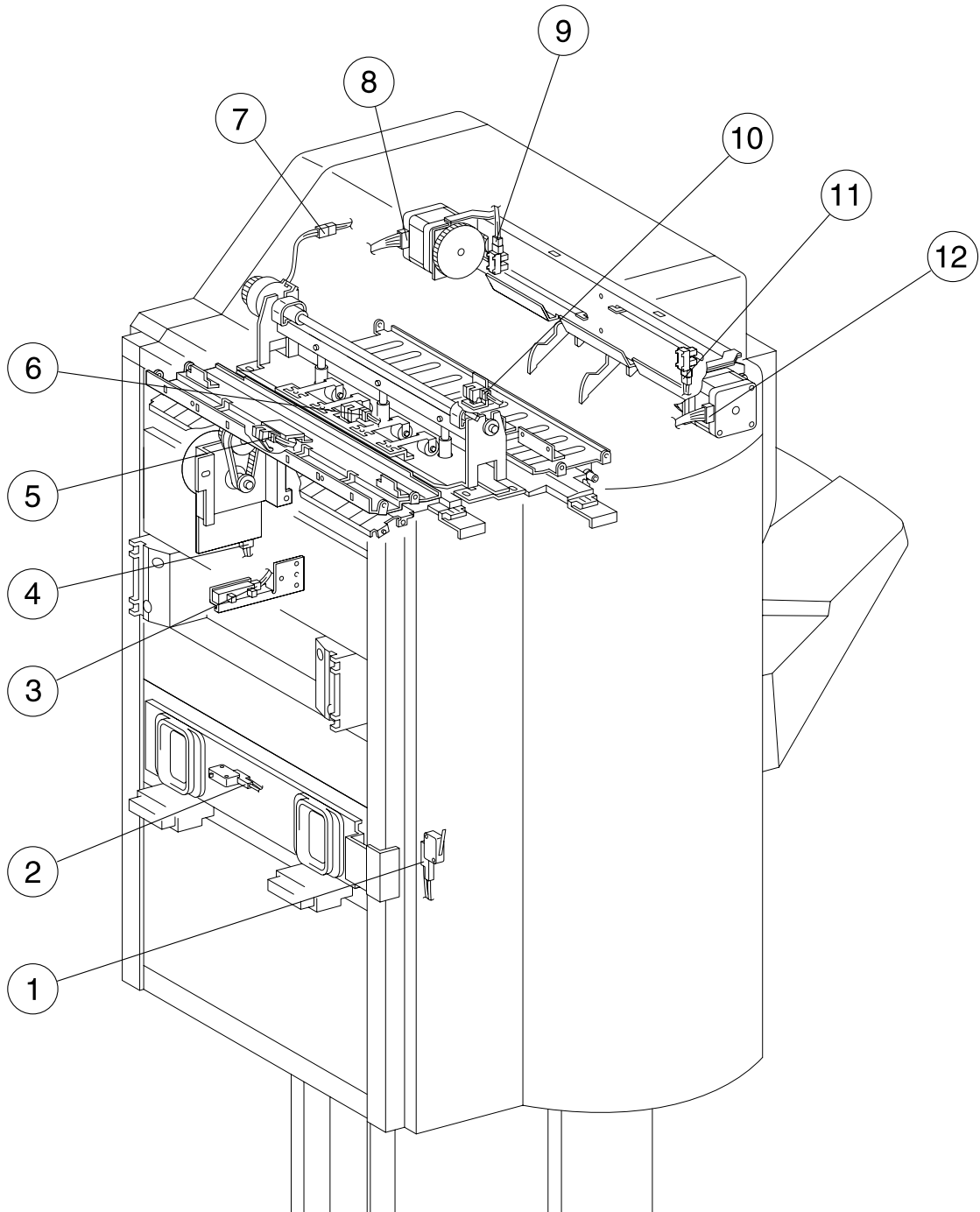

### Location Map 3

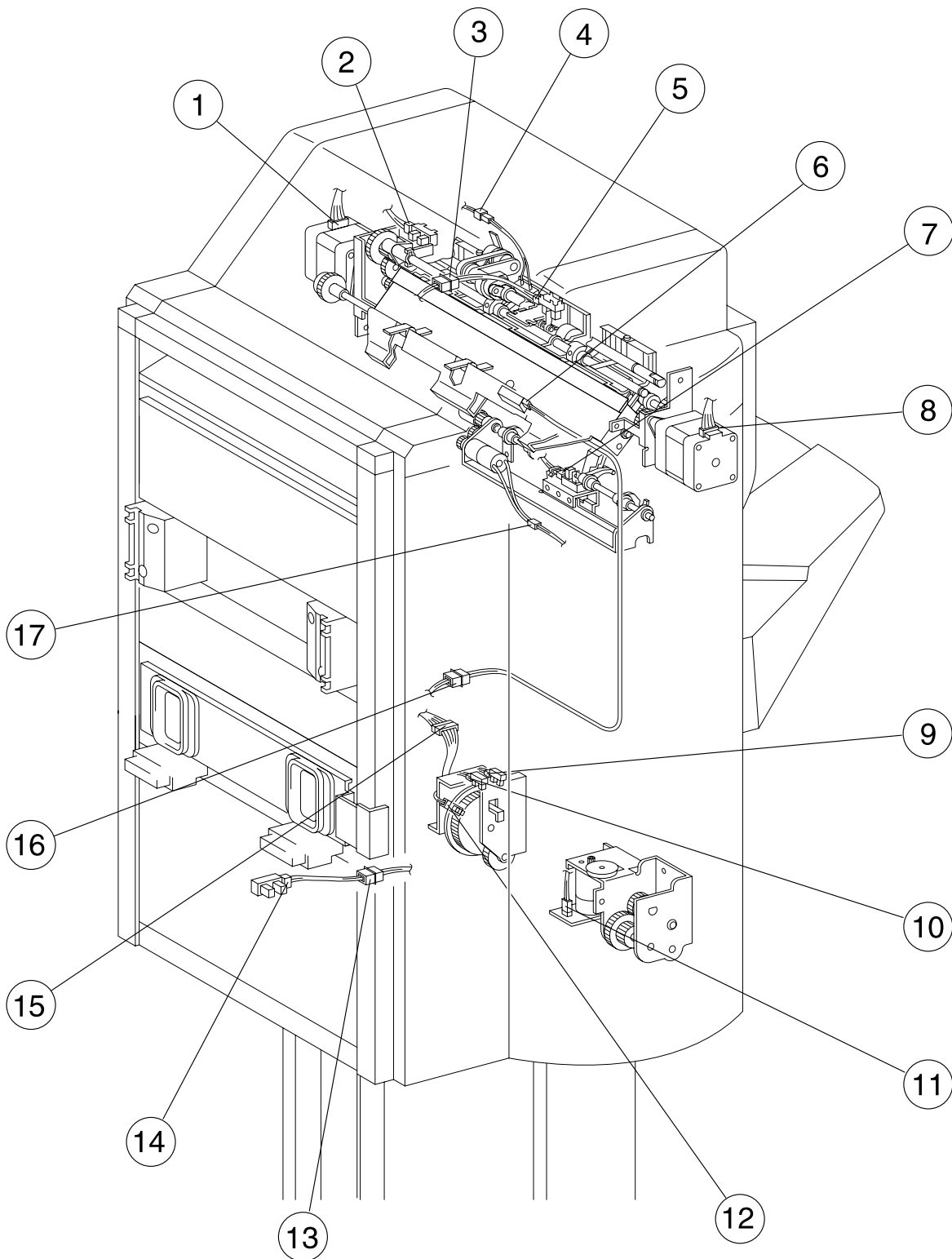

Location Map 4

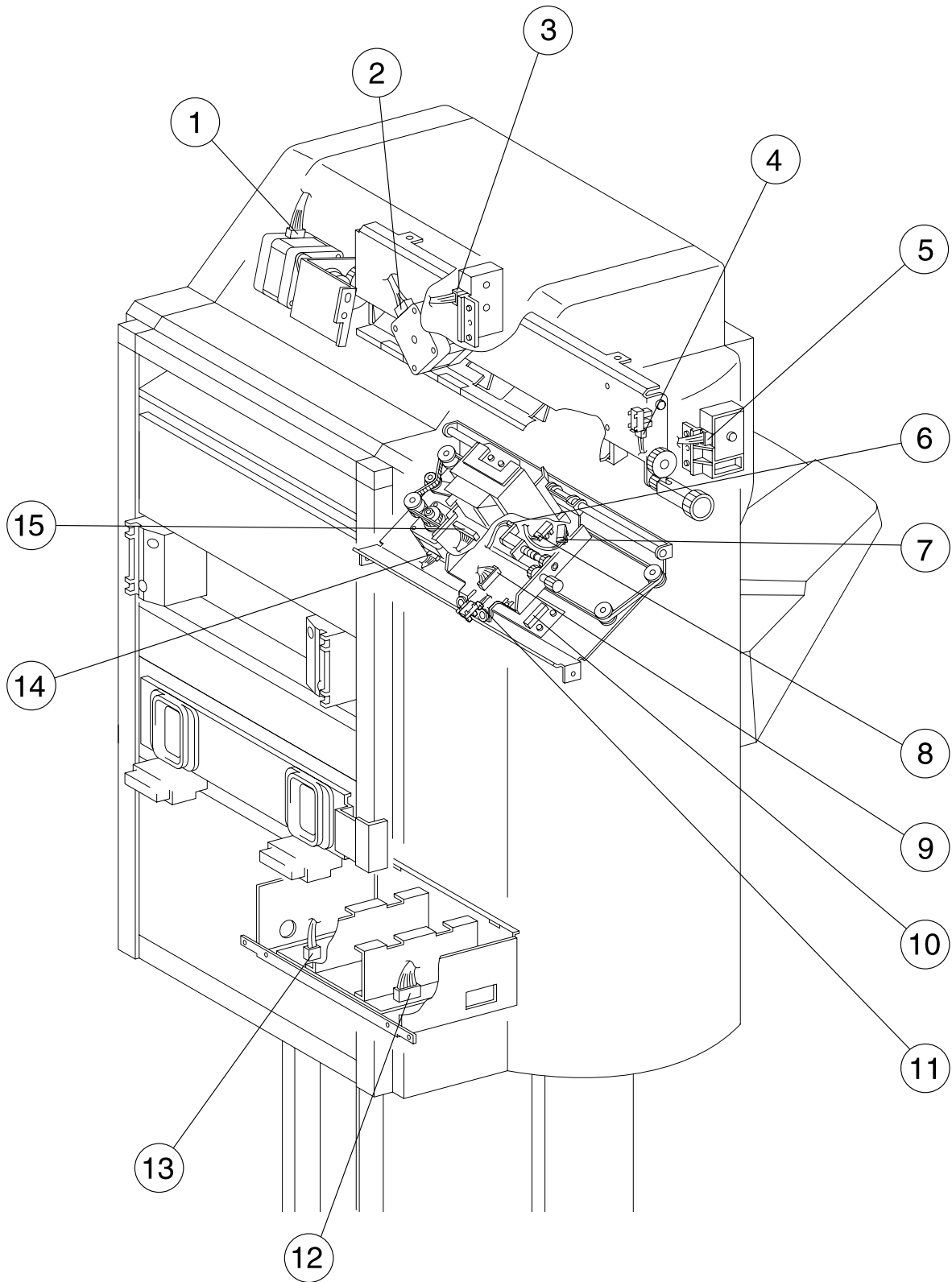

### Location Map 5

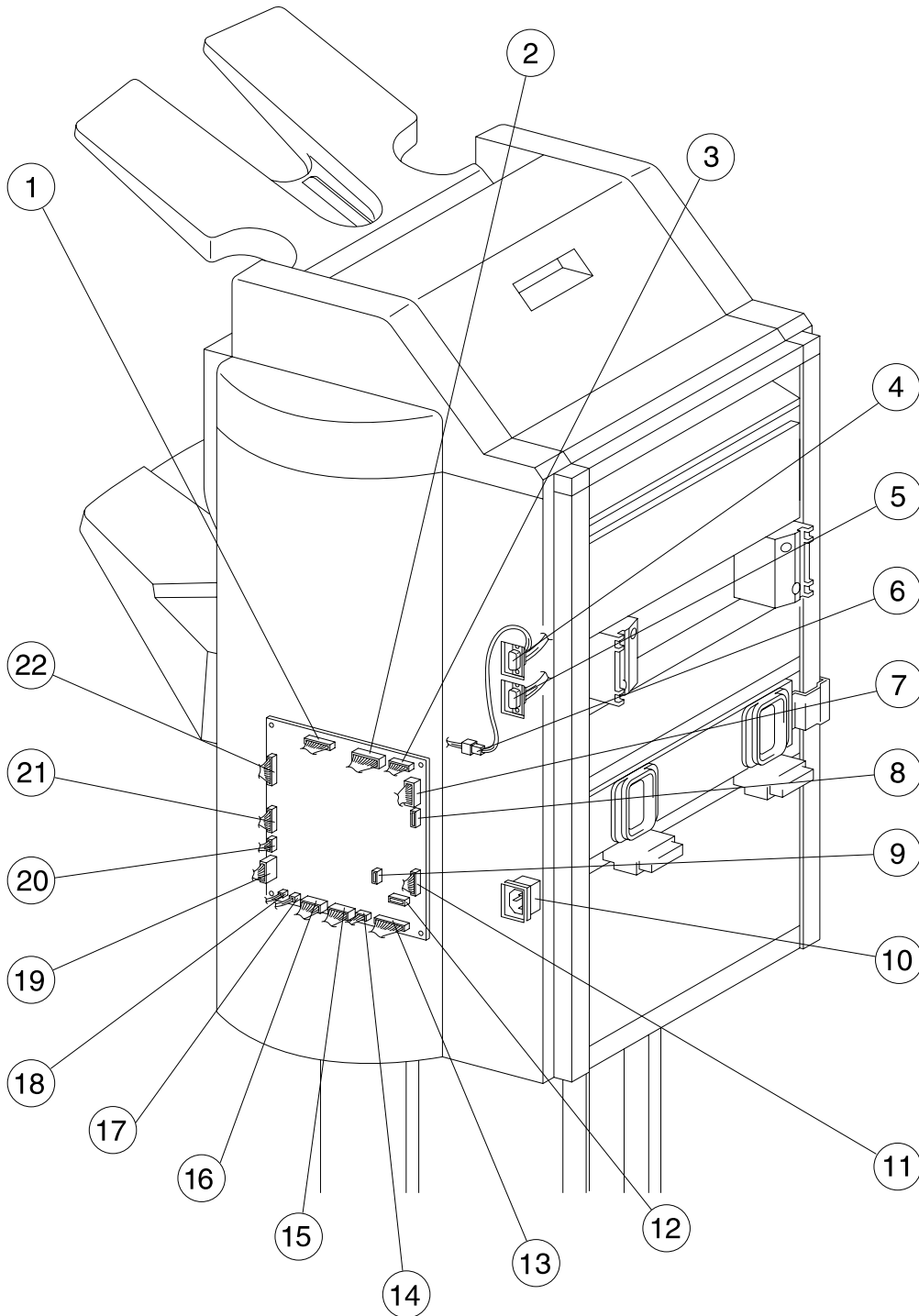

### Location Map 6

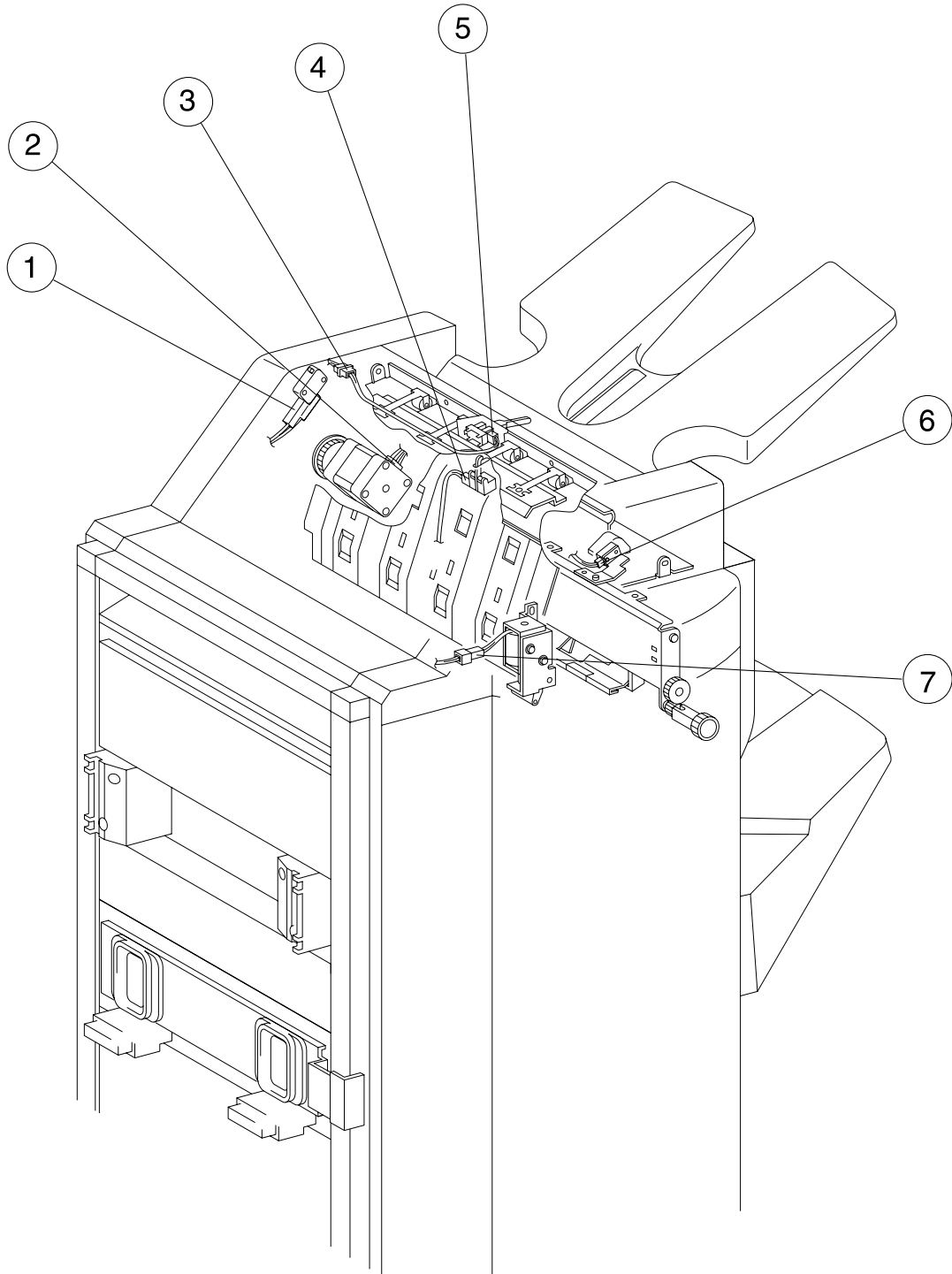

## Wiring Diagram Notations

The wiring diagrams presented in this manual use the following circuit notations to describe components and signal paths within the printer.

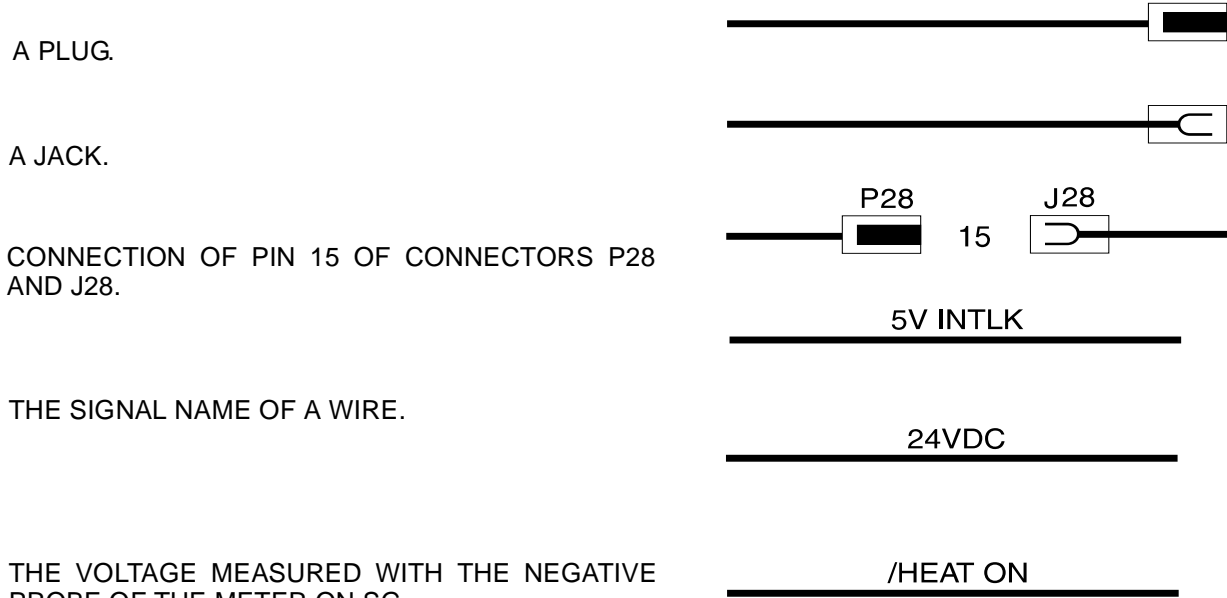

/ = The voltage goes LOW when the signal is ON.  
 In this case, the HEAT signal is ON, so the normal voltage of 4.2 V dc drops to 0 V dc.

GND GROUND.

SGND SIGNAL GROUND.

PGND FRAME GROUND.

RTN RETURN.

There is continuity between SG and RTN.  
 Continuity between FG and SG depends on circuit specifications.

\$ \$ in a signal name indicates the signal is coming from the MCU CPU.

# # in a signal name indicates the signal is going to the MCU CPU.

TTL TTL displayed in the HIGH level or LOW level columns of the signal tables indicate the signal is ECL\_CMOS compatible.

#\$ Interactive communication signal.

## Analog signal.



# Master Wiring Diagram

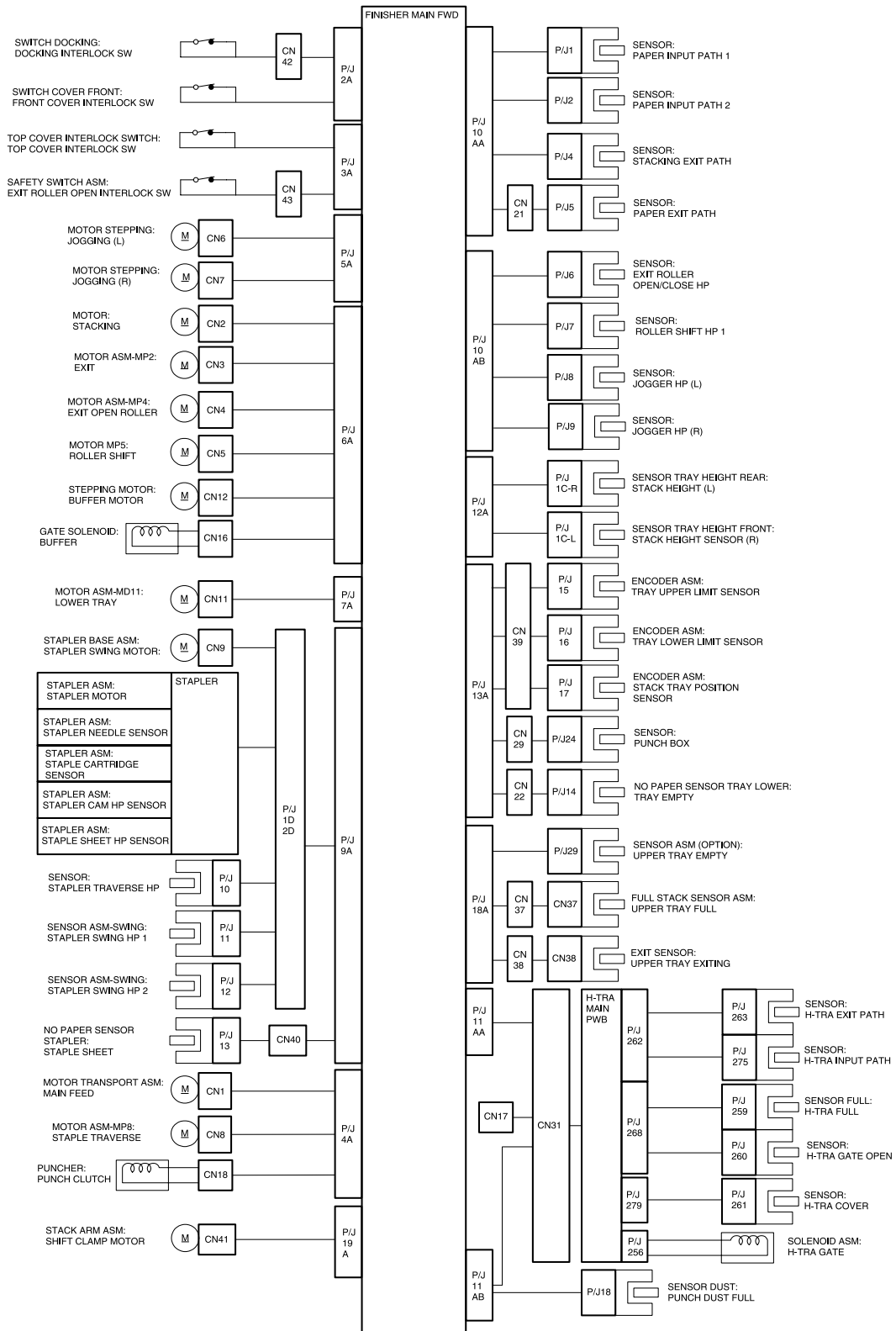

# 4025-Finisher

## BD1 FINISHER MAIN PWB (H-TRA)

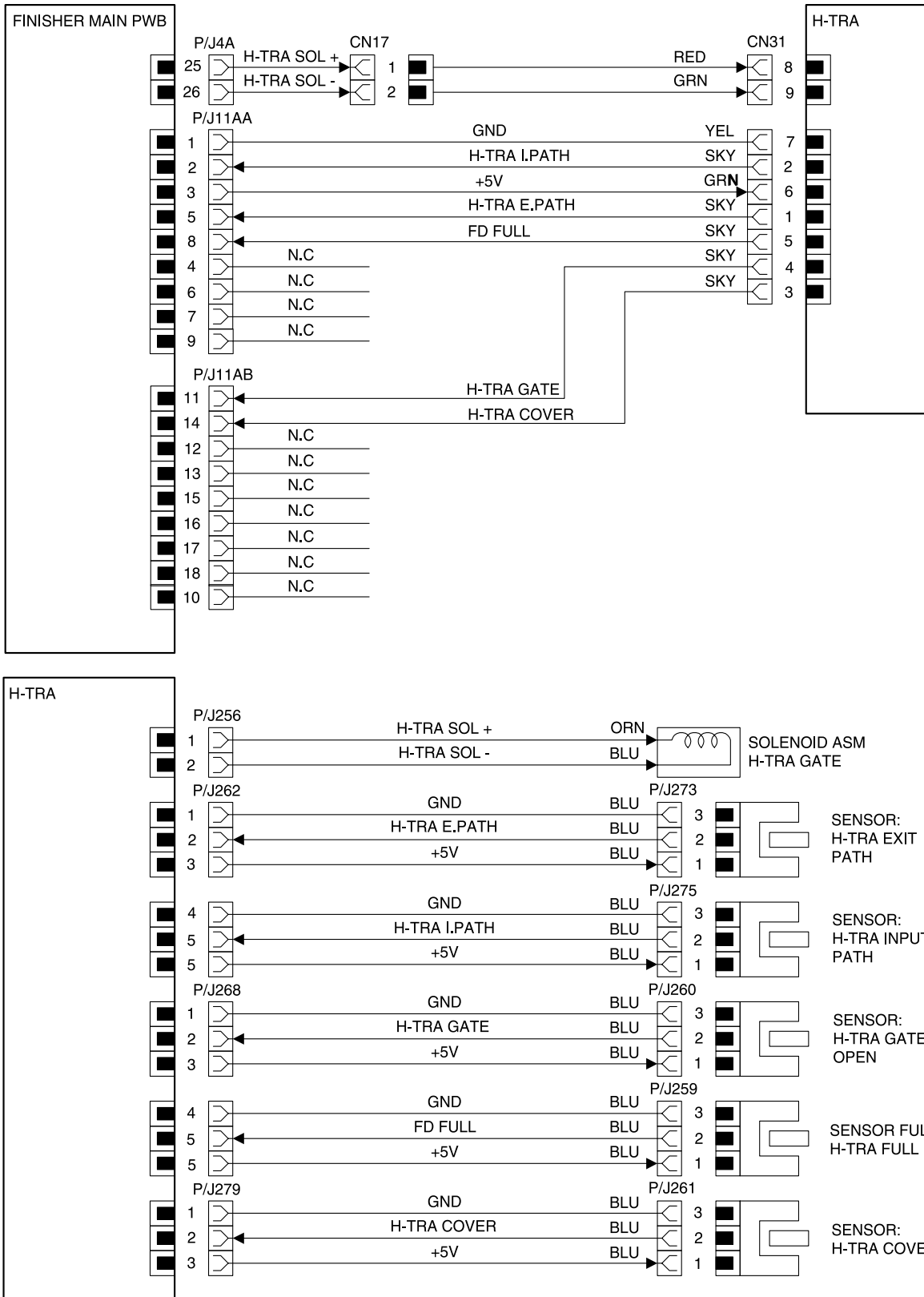

## 4025-Finisher

<b>Signal Name</b>	<b>Description</b>
H-TRA SOL-	Controls the gate open/close of the horizontal transfer tray.
H-TRA SOL+	Controls the gate open/close of the horizontal transfer tray.
H-TRA GATE	Detects the gate open/close of the horizontal transfer tray. 5 V = OPEN, 0 V = CLOSE.
H-TRA COVER	Detects the top cover open/close of the horizontal transfer tray. 5 V = OPEN, 0 V = CLOSE.
H-TRA I.PATH	Detects the paper feed-in to the horizontal transfer tray. 5 V = Paper feed-in, 0 V = No paper feed-in.
H-TRA E.PATH	Detects the paper delivery from the horizontal transfer tray. 5 V = Paper delivery, 0 V = No paper delivery.
FD FULL	Detects delivered paper full in the machine. 5 V = Delivered paper not full, 0 V = Delivered paper full.

**BD2 FINISHER MAIN PWB (PAPER INPUT)**

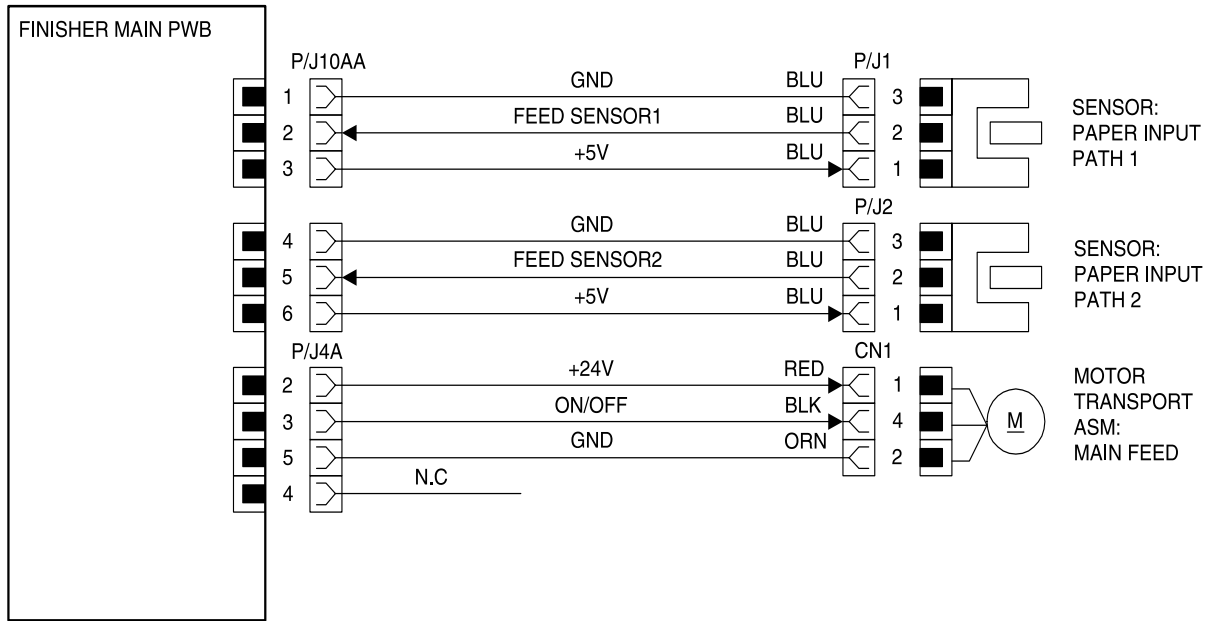

Signal Name	Description
ON/OFF	Switches the Main Feed Motor on and off. 5 V = Enable to rotate, 0 V = Disable to rotate.
FEED SENSOR1	Detects paper feed-in. 5 V = Paper fed-in, 0 V = No paper fed-in.
FEED SENSOR2	Detects paper feed-in. 5 V = Paper fed-in, 0 V = No paper fed-in.

**BD3 FINISHER MAIN PWB (PUNCHER)**

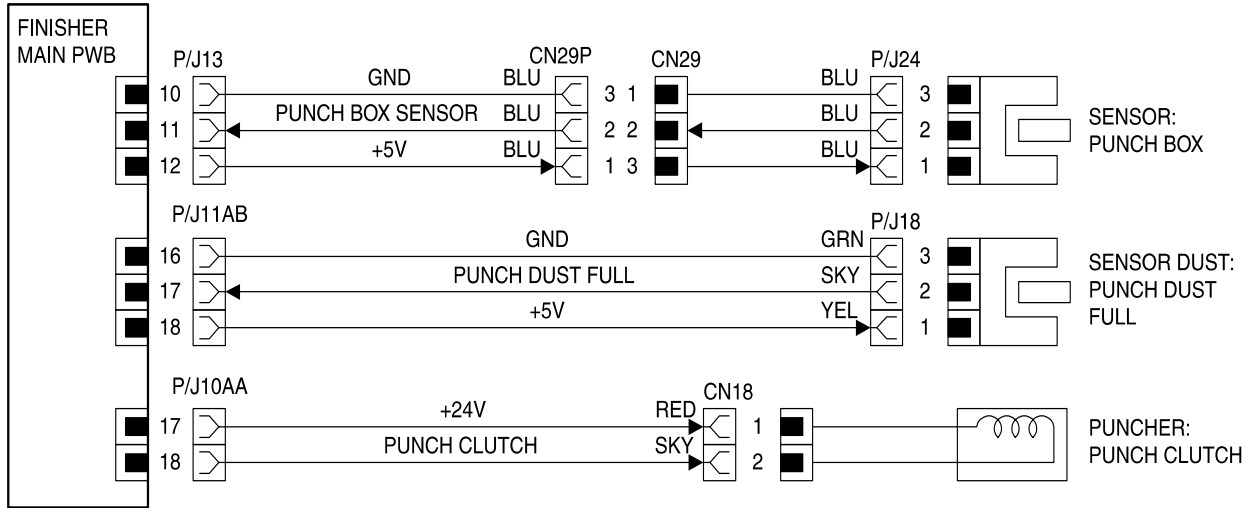

Signal Name	Description
PUNCH CLUTCH	Rotates forward with 24 V power supply.
PUNCH BOX SENSOR	Detects the presence of the punch dust box. 5 V = Box present, 0 V = No box.
PUNCH DUST FULL	Detects the punch us box full. 5 V = No punch dust, 0 V = Punch dust full.

**BD4 FINISHER MAIN PWB (PAPER OUTPUT)**

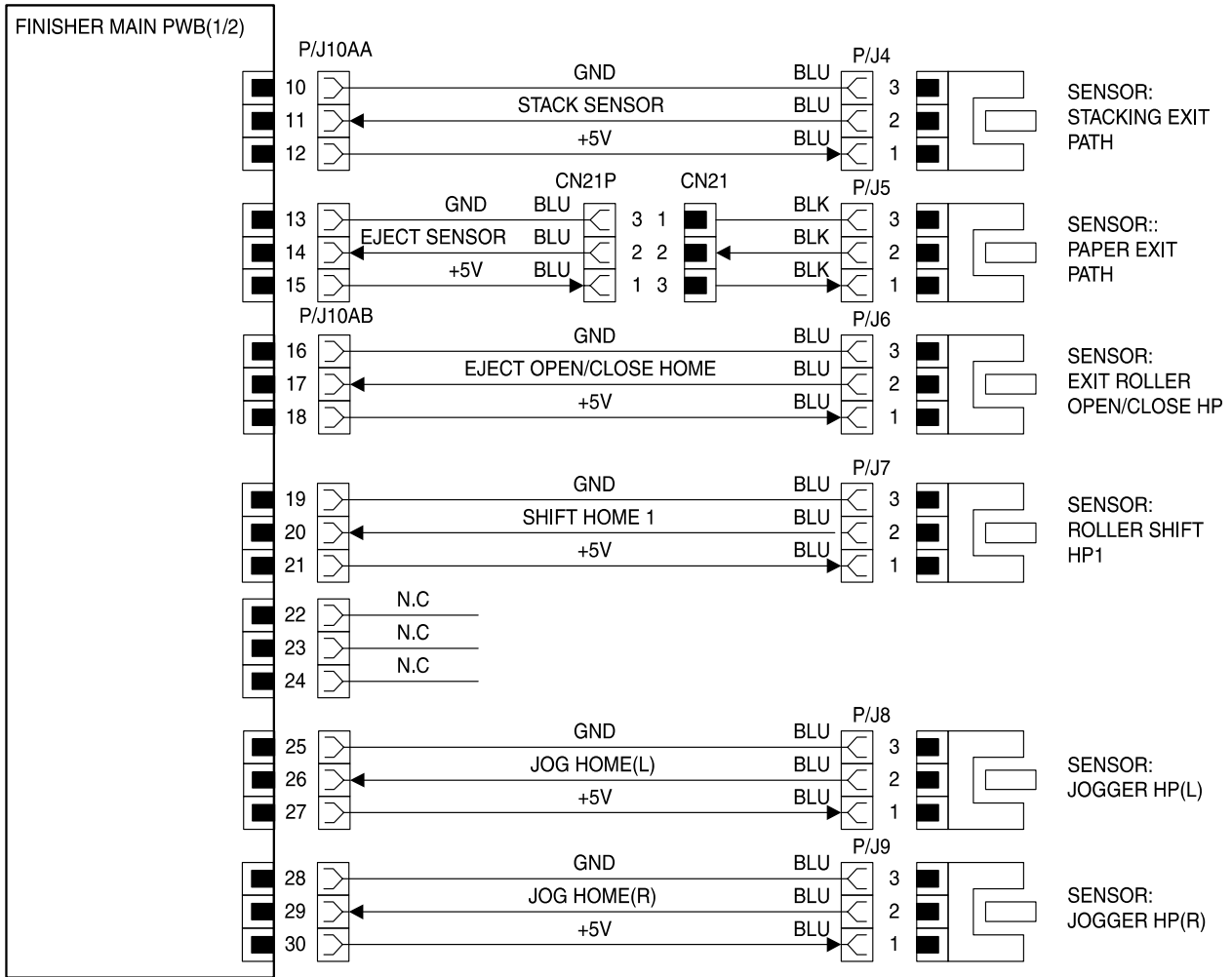

Signal Name	Description
EJECT SENSOR	Detects paper delivery. 5 V = Paper delivered, 0 V = No paper delivered.
STACK SENSOR	Detects paper delivery. 5 V = Paper delivered, 0 V = No paper delivered.
EJECT OPEN/CLOSE HOME	Detects paper feed-in. 5 V = Paper fed-in, 0 V = No paper fed-in.
SHIFT HOME1	Detects the home position of the shift operation. 5 V = Home position, 0 V = Not home position.
JOG HOME(L)	Detects the home position of the jogging operation. 5 V = Home position, 0 V = Not home position.
JOG HOME(R)	Detects the home position of the jogging operation. 5 V = Home position, 0 V = Not home position.

**BD5 FINISHER MAIN PWB (MOTORS)**

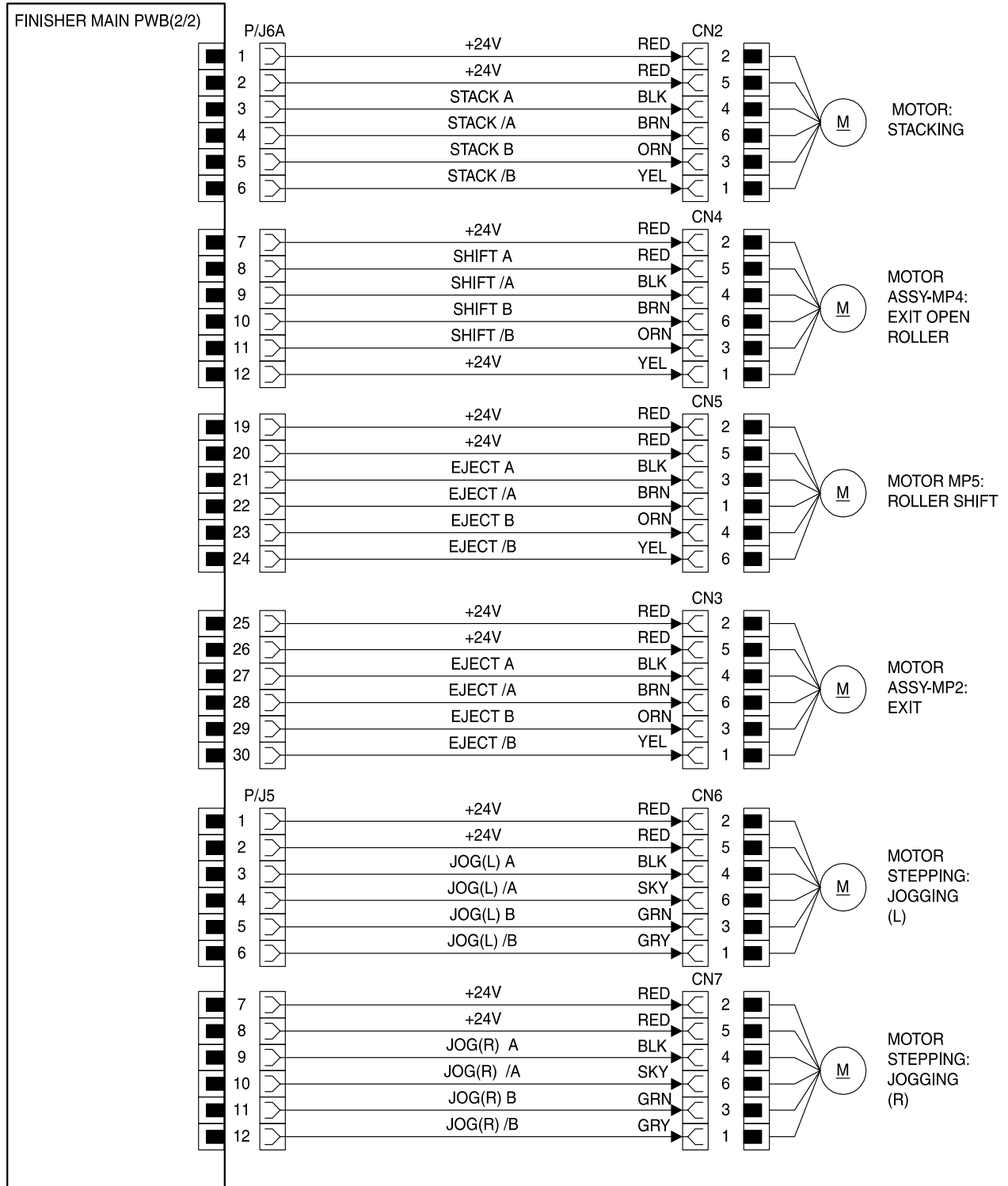

## 4025-Finisher

Signal Name	Description
EJECT A	Rotates the Ejector Open/Shut Motor by pulse signals from the Finisher Main PWB.
EJECT /A	Rotates the Ejector Open/Shut Motor by pulse signals from the Finisher Main PWB.
EJECT B	Rotates the Ejector Open/Shut Motor by pulse signals from the Finisher Main PWB.
EJECT /B	Rotates the Ejector Open/Shut Motor by pulse signals from the Finisher Main PWB.
STACK A	Rotates the Stack Motor by pulse signals from the Finisher Main PWB.
STACK /A	Rotates the Stack Motor by pulse signals from the Finisher Main PWB.
STACK B	Rotates the Stack Motor by pulse signals from the Finisher Main PWB.
STACK /B	Rotates the Stack Motor by pulse signals from the Finisher Main PWB.
EJECT A	Rotates the Eject Motor by pulse signals from the Finisher Main PWB.
EJECT /A	Rotates the Eject Motor by pulse signals from the Finisher Main PWB.
EJECT B	Rotates the Eject Motor by pulse signals from the Finisher Main PWB.
EJECT /B	Rotates the Eject Motor by pulse signals from the Finisher Main PWB.
SHIFT A	Rotates the Shift Motor by pulse signals from the Finisher Main PWB.
SHIFT /A	Rotates the Shift Motor by pulse signals from the Finisher Main PWB.
SHIFT B	Rotates the Shift Motor by pulse signals from the Finisher Main PWB.
SHIFT /B	Rotates the Shift Motor by pulse signals from the Finisher Main PWB.
JOG (L)A	Rotates the Jogging Motor by pulse signals from the Finisher Main PWB.
JOG (L)/A	Rotates the Jogging Motor by pulse signals from the Finisher Main PWB.
JOG (L)B	Rotates the Jogging Motor by pulse signals from the Finisher Main PWB.
JOG (L)/B	Rotates the Jogging Motor by pulse signals from the Finisher Main PWB.
JOG (R)A	Rotates the Jogging Motor (L) by pulse signals from the Finisher Main PWB.
JOG (R)/A	Rotates the Jogging Motor (L) by pulse signals from the Finisher Main PWB.
JOG (R) B	Rotates the Jogging Motor (L) by pulse signals from the Finisher Main PWB.
JOG (R) /B	Rotates the Jogging Motor (L) by pulse signals from the Finisher Main PWB.



4025-Finisher

BD6 FINISHER MAIN PWB (STAPLER(1/2))

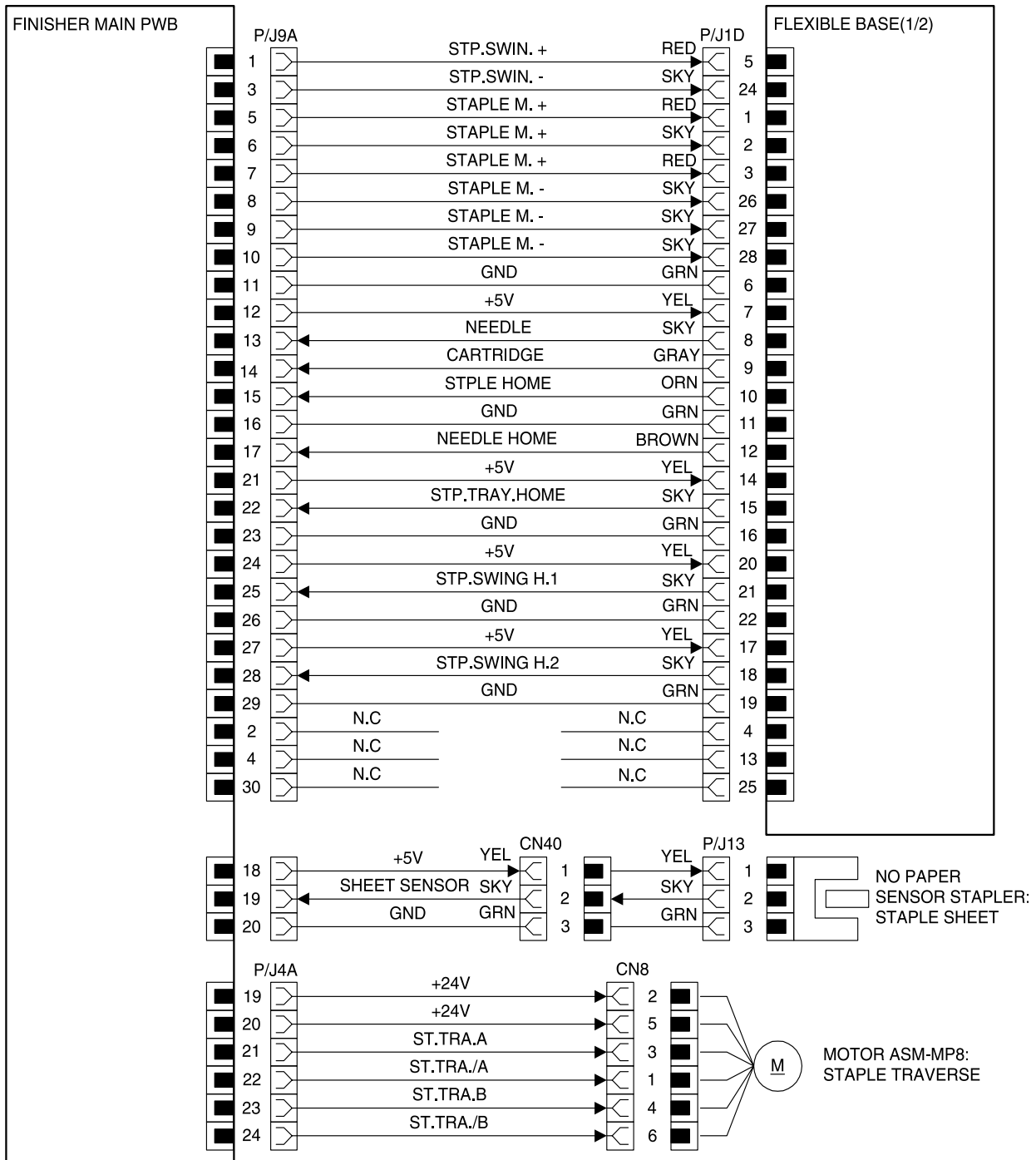

## 4025-Finisher

Signal Name	Description
STP.SWIN. +	Rotates forward with 24 V power supply.
STP.SWIN. -	Rotates reversely with 24 V power supply.
STAPLE M. +	Rotates forward with 24 V power supply.
STAPLE M. +	Rotates forward with 24 V power supply.
STAPLE M. -	Rotates reversely with 24 V power supply.
STAPLE M. -	Rotates reversely with 24 V power supply.
ST.TRV. A	Rotates the Staple Traverse Motor by pulse signals from the Finisher Main PWB.
ST.TRV. /A	Rotates the Staple Traverse Motor by pulse signals from the Finisher Main PWB.
ST.TRV. B	Rotates the Staple Traverse Motor by pulse signals from the Finisher Main PWB.
ST.TRV. /B	Rotates the Staple Traverse Motor by pulse signals from the Finisher Main PWB.
SHEET SENSOR	Detects paper at stapling operation. 5 V = No paper in stacker, 0 V = Paper present in stacker.
STP.SWING H.1	Detects the dual position angle of the 45° stapling. 5 V = Not home position, 0 V = Home position.
STP.SWING H.2	Detects the dual position angle of the 45° stapling. 5 V = Not home position, 0 V = Home position.
SHEET SENSOR	Detects paper at stapling operation. 5 V = No paper in stacker, 0 V = Paper present in stacker.
NEEDLE	Detects the presence of staples. 0 V = Staple present, 5 V = No staple.
STPLE HOME	Detects the home position at stapling operation. 5 V = Not home position, 0 V = Home position.
NEEDLE HOME	Detects the home position at staple supply. 5 V = Not home position, 0 V = Home position.
CARTRIDGE	Detects the presence of staples. 0 V = Cartridge present in Staple, 5 V = No Cartridge in Staple.
STP.TRAY.HOME	Detects the home position of the staple unit. 5 V = Home position, 0 V = Not home position.

4025-Finisher

**BD7 FINISHER MAIN PWB (STAPLER(2/2))**

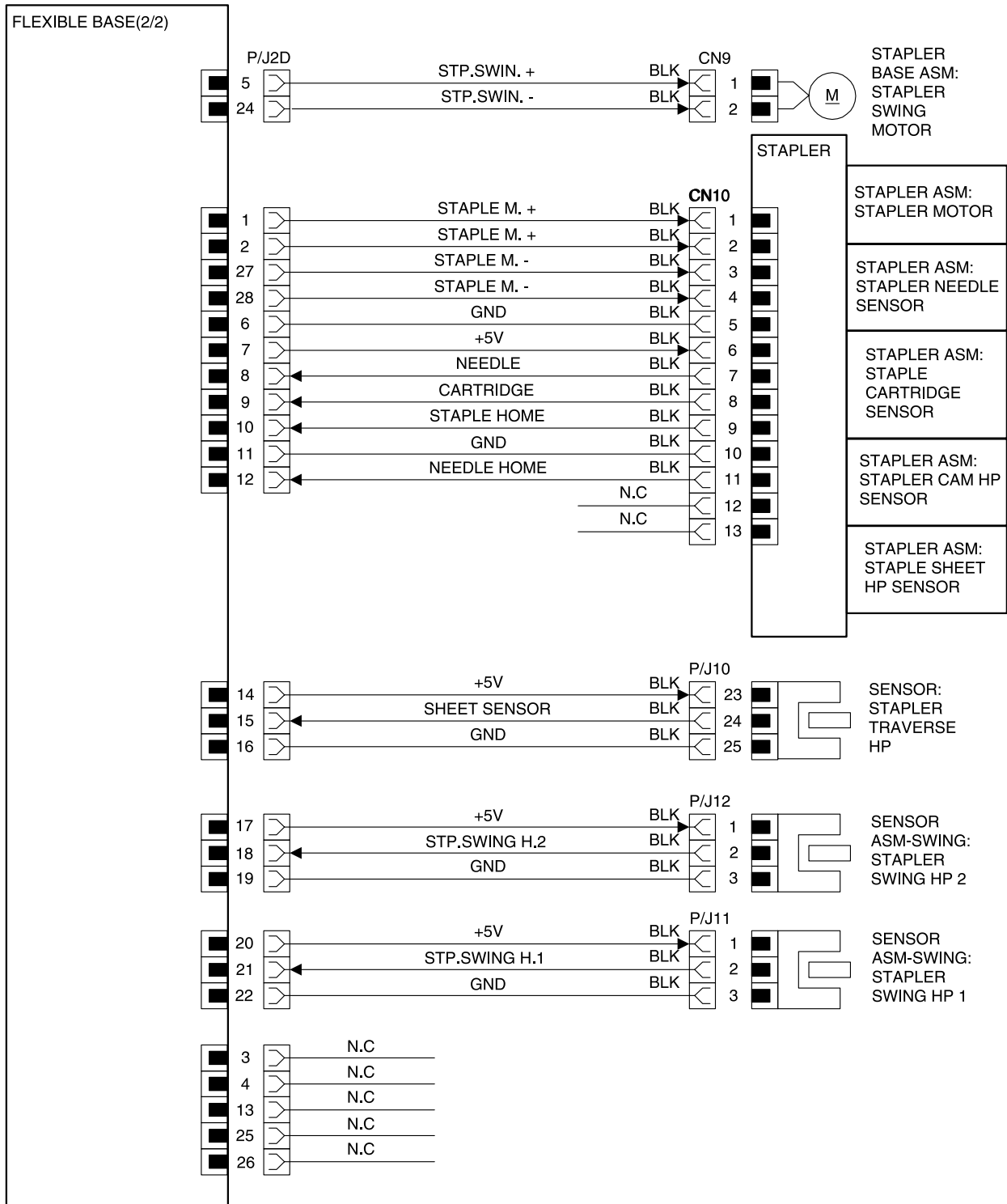

## 4025-Finisher

Signal Name	Description
STP.SWIN. +	Rotates forward with 24 V power supply.
STP.SWIN. -	Rotates reversely with 24 V power supply.
STAPLE M. +	Rotates forward with 24 V power supply.
STAPLE M. -	Rotates reversely with 24 V power supply.
STP.SWING H.1	Detects the dual position angle of the 45° stapling. 5 V = Not home position, 0 V = Home position.
STP.SWING H.2	Detects the dual position angle of the 45° stapling. 5 V = Not home position, 0 V = Home position.
NEEDLE	Detects the presence of staples. 0 V = Staple present, 5 V = No staple.
STPLE HOME	Detects the home position at stapling operation. 5 V = Not home position, 0 V = Home position.
NEEDLE HOME	Detects the home position at staple supply. 5 V = Not home position, 0 V = Home position.
CARTRIDGE	Detects the presence of staples. 0 V = Cartridge present in Staple, 5 V = No Cartridge in Staple.
STPLE HOME	Detects the home position at stapling operation. 5 V = Not home position, 0 V = Home position.

**BD8 FINISHER MAIN PWB (TRAY)**

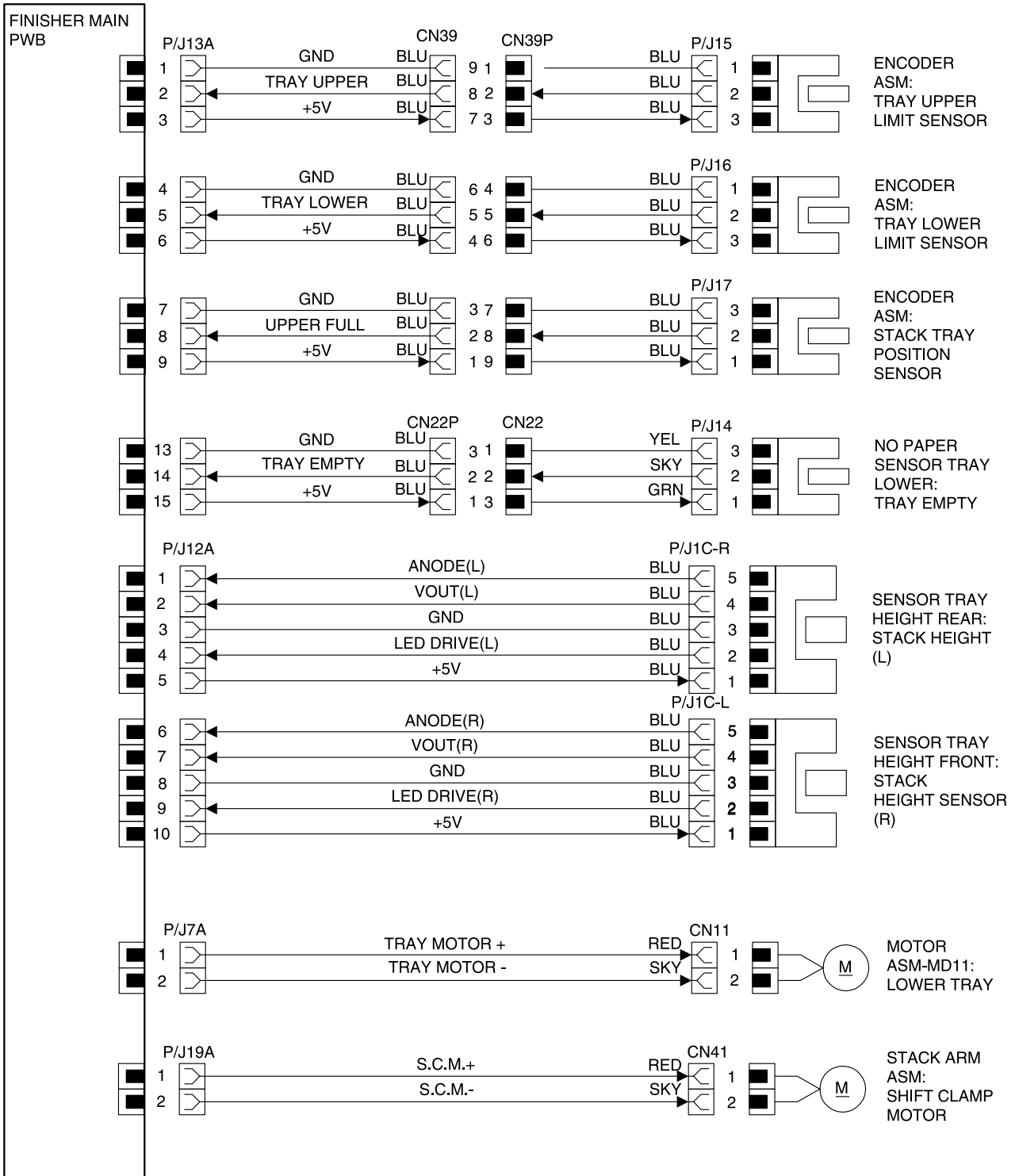

## 4025-Finisher

Signal Name	Description
TRAY MOTOR +	Rotates forward with 24 V power supply.
TRAY MOTOR -	Rotates reversely with 24 V power supply.
TRAY LOWER	Detects the lower limit position of the tray. 5 V = Not home position, 0 V = Home position.
TRAY EMPTY	Detects the presence of paper on tray. 5 V = Paper present on tray, 0 V = No paper on tray.
UPPER FULL	Detects paper delivery on tray. 5 V = Paper delivered, 0 V = No paper delivered.
TRAY UPPER	Detects the upper limit position of the tray. 5 V = Home position, 0 V = Not home position.
ANODE(L)	LED actuation signal for the paper stacking height detection on lower position.
VOUT(L)	Detects the paper stacking height on upper position (Receive).
LED DRIVE(L)	Detects the paper stacking height on lower position (Send).
ANODE(R)	LED actuation signal for the paper stacking height detection on lower position.
VOUT(R)	Detects the paper stacking height on upper position (Receive).
LED DRIVE(R)	Detects the paper stacking height on lower position (Send).
S.C.M.+	Rotates forward with 24 V power supply.
S.C.M.-	Rotates reversely with 24 V power supply.

**BD9 FINISHER MAIN PWB (INTERLOCK)**

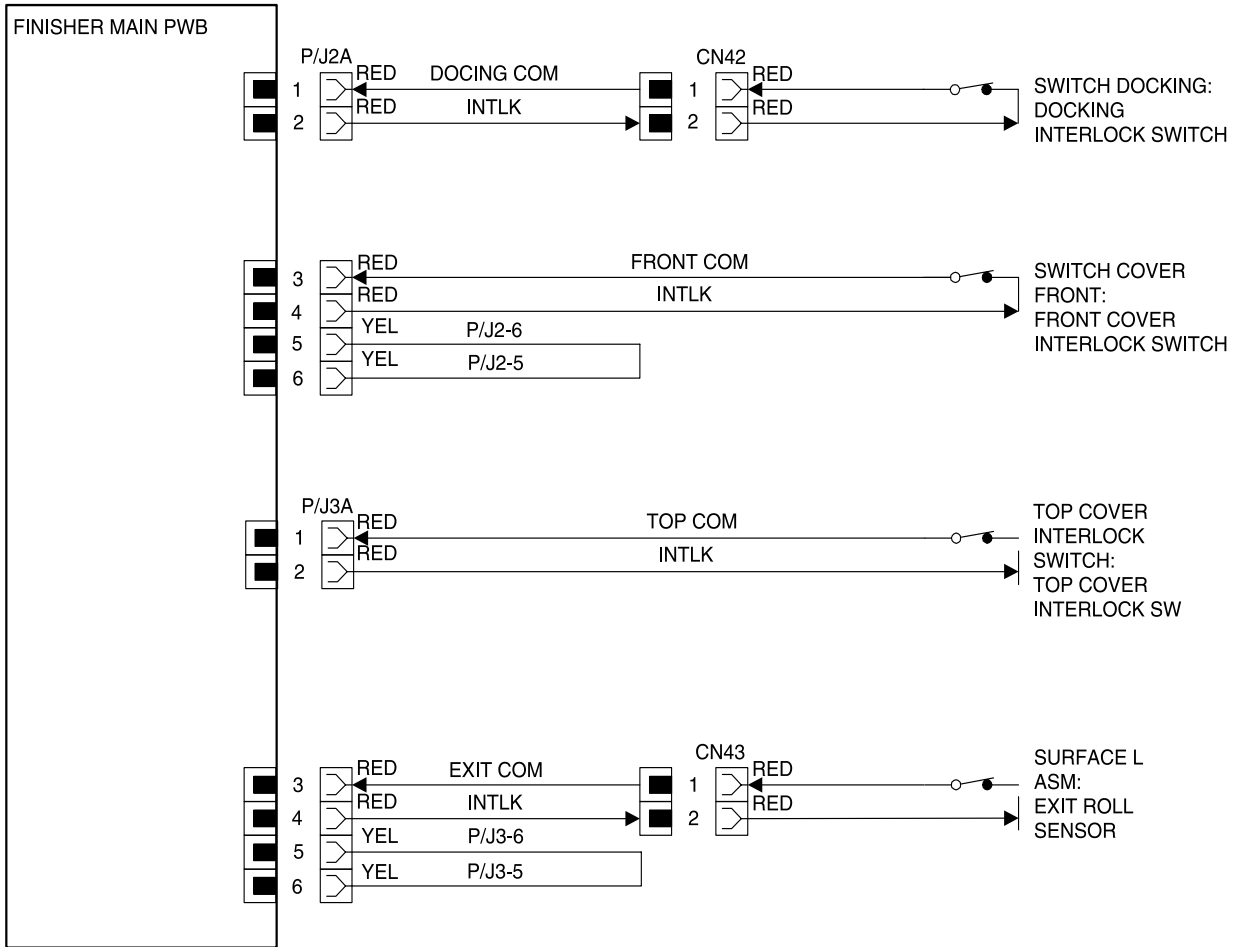

Signal Name	Description
DOCING COM	Switch COMON Signal.
FRONT COM	Switch COMON Signal.
TOP COM	Switch COMON Signal.
EXIT COM	Switch COMON Signal.
INTLK	Switch OPEN Signal.

**BD10 FINISHER MAIN PWB (TOP TRAY)**

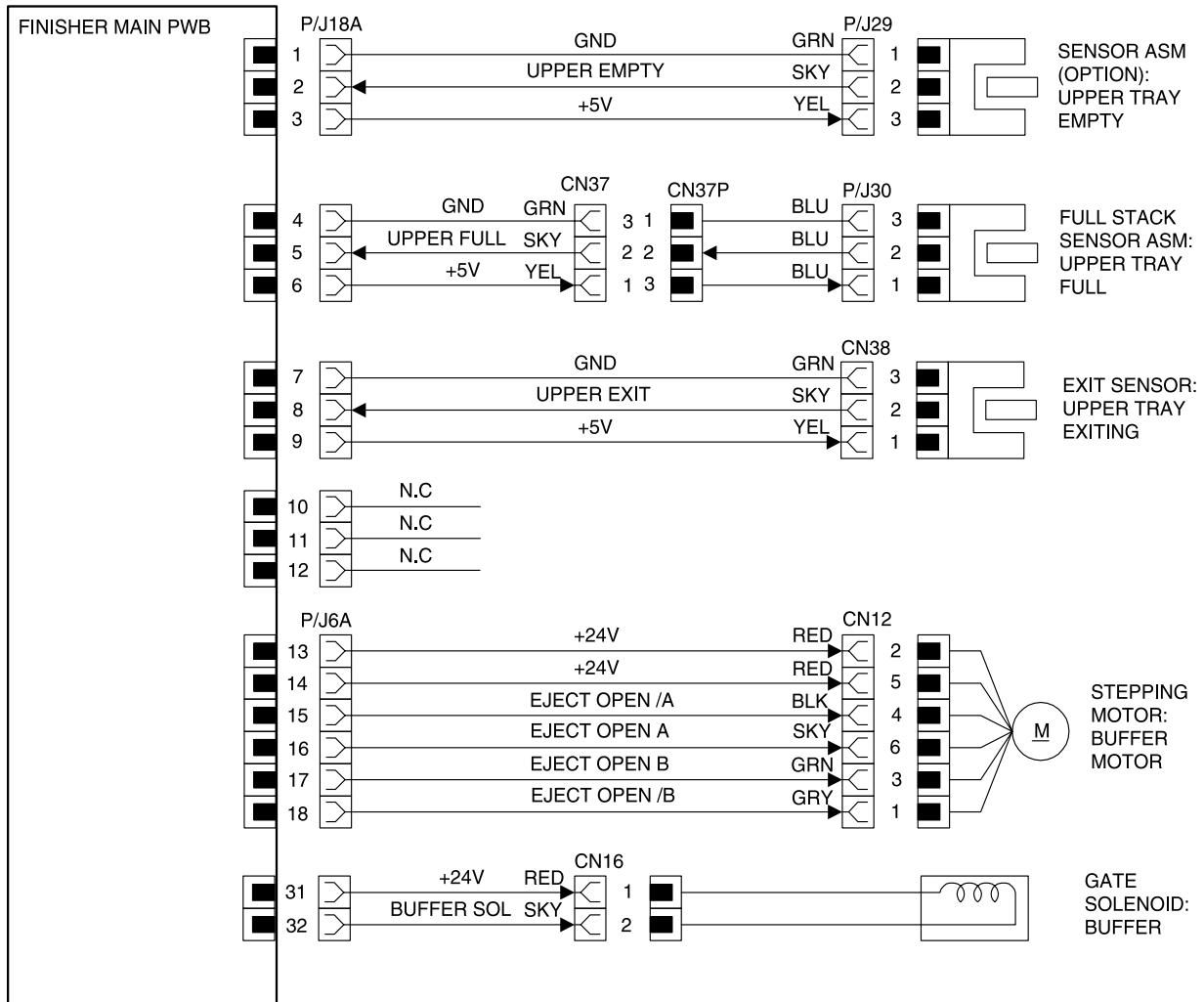



**BD11JEZ-9P (PWBA I/O (EG))**

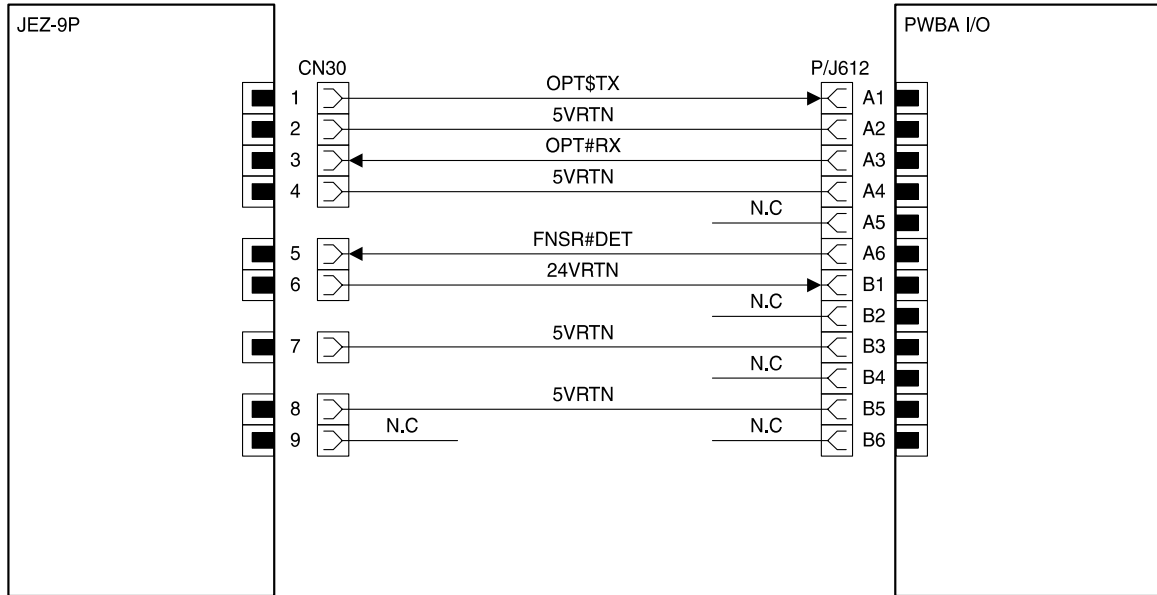

Signal Name	Description
UPPER EMPTY	Detects the upper limit position of the tray. 5 V = Home position, 0 V = Not home position.
UPPER FULL	Detects the top surface of paper stacked on tray.
UPPER EXIT	5 V = Paper delivered, 0 V = No paper delivered.
BUFFER SOL	Controls the gate open/close of the horizontal transfer upper tray.
EJECT OPEN A	Rotates the Ejector Open/Shut Motor by pulse signals from the Finisher Main PWB.
EJECT OPEN /A	Rotates the Ejector Open/Shut Motor by pulse signals from the Finisher Main PWB.
EJECT OPEN B	Rotates the Ejector Open/Shut Motor by pulse signals from the Finisher Main PWB.
EJECT OPEN /B	Rotates the Ejector Open/Shut Motor by pulse signals from the Finisher Main PWB.

4025-Finisher

BD12 FINISHER MAIN PWB (JEZ-9P)

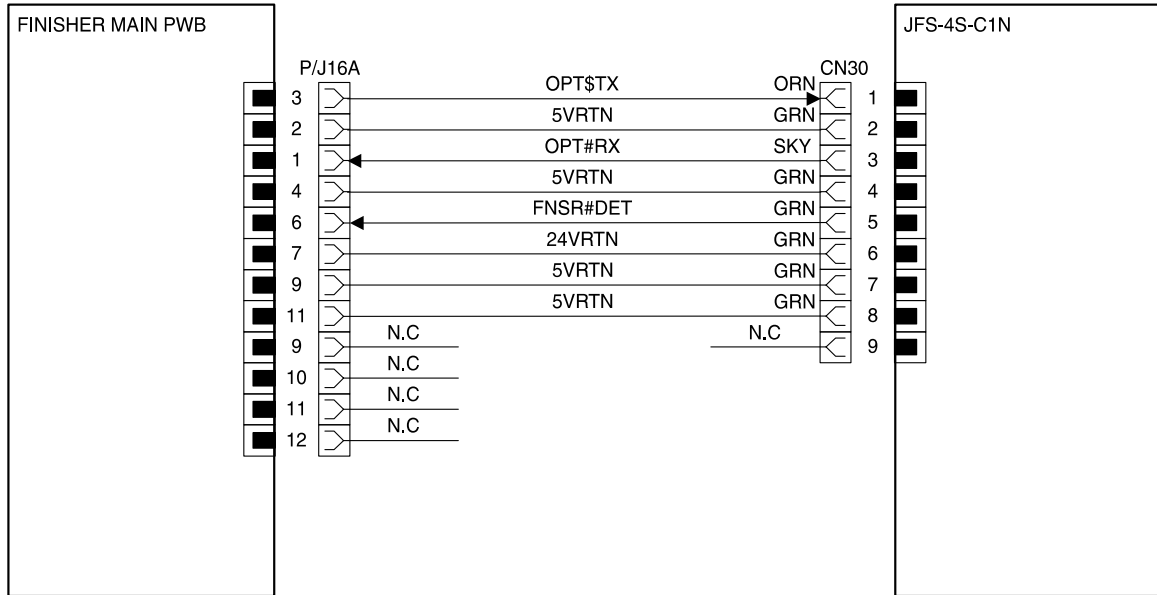

Signal Name	Description
OPT\$TX	Communication signal between printer and Finisher for I/O.
OPT#RX	Communication signal between printer and Finisher for I/O.
FINR#DET	Ground.

Signal Name	Description
OPT\$TX	Communication signal between printer and Finisher for I/O.
OPT#RX+	Communication signal between printer and Finisher for I/O.
FINR#DET	Ground.

**BD13 INLET (PWBA I/O (EG))**

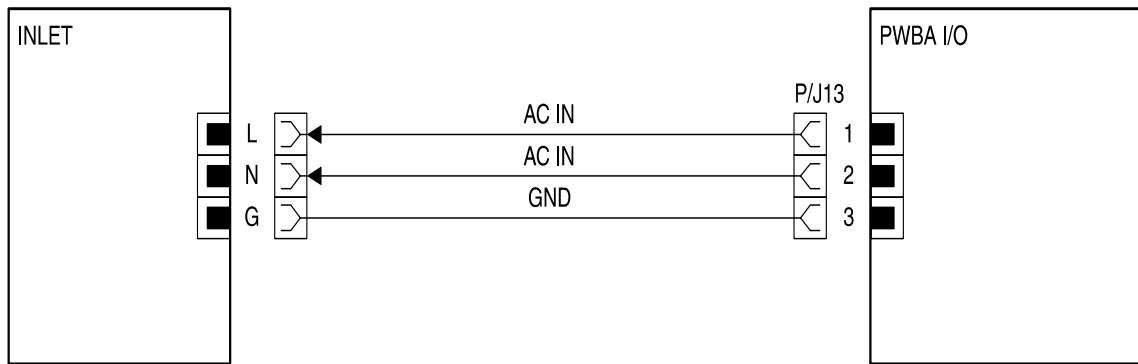

Signal Name	Description
AC IN	AC(100-230 V) Input.

# 4025-Finisher

## BD14 FINISHER MAIN PWB (INLET)

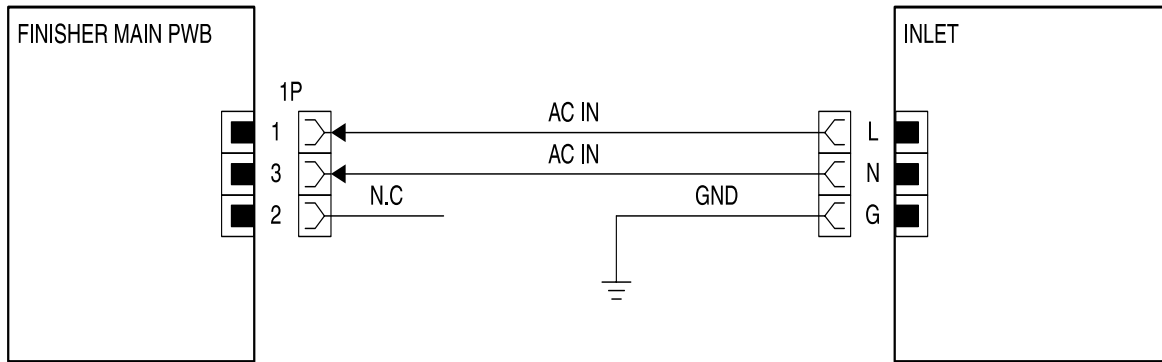

Signal Name	Description
AC IN	AC(100-230 V) Input.

---

## 6. Preventative Maintenance

This chapter describes procedures for printer preventive maintenance. Following these recommendations can help prevent problems and maintain optimum performance.

---

### Safety Inspection Guide

The purpose of this inspection guide is to aid you in identifying unsafe conditions.

If any unsafe conditions exist, find out how serious the hazard could be and if you can continue before you correct the hazard.

Check the following items:

- Damaged, missing, or altered parts, especially in the area of the On/Off switch and the power supply
- Damaged, missing, or altered covers, especially in the area of the top cover and the power supply cover
- Possible safety exposure from any non-Lexmark attachments

---

### Scheduled Maintenance

There is no scheduled maintenance on the Lexmark W820 (4025) Finisher.

## 4025-Finisher

## 7. Parts Catalog

### How to Use This Parts Catalog

- The callout numbers shown in each parts illustration correspond to the parts list numbers for that illustration.
- The capital letters "C," "E," "KL," and "S" shown in an illustration stand for C-ring, E-ring, Clamp, and Screw, respectively.
- NS: (Not Shown) in the Asm-Index column indicates that the part is procurable but is not pictured in the illustration.

Printer serial number labels are on the rear of the printer and inside the front cover.

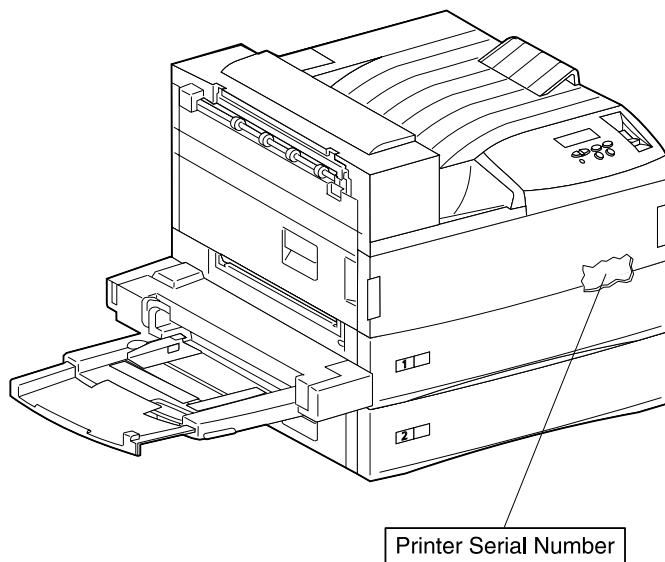
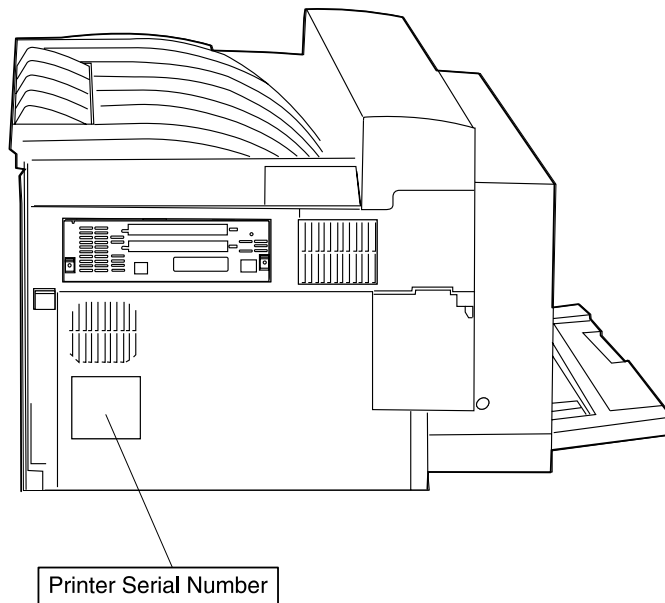

4025-Finish

Assem

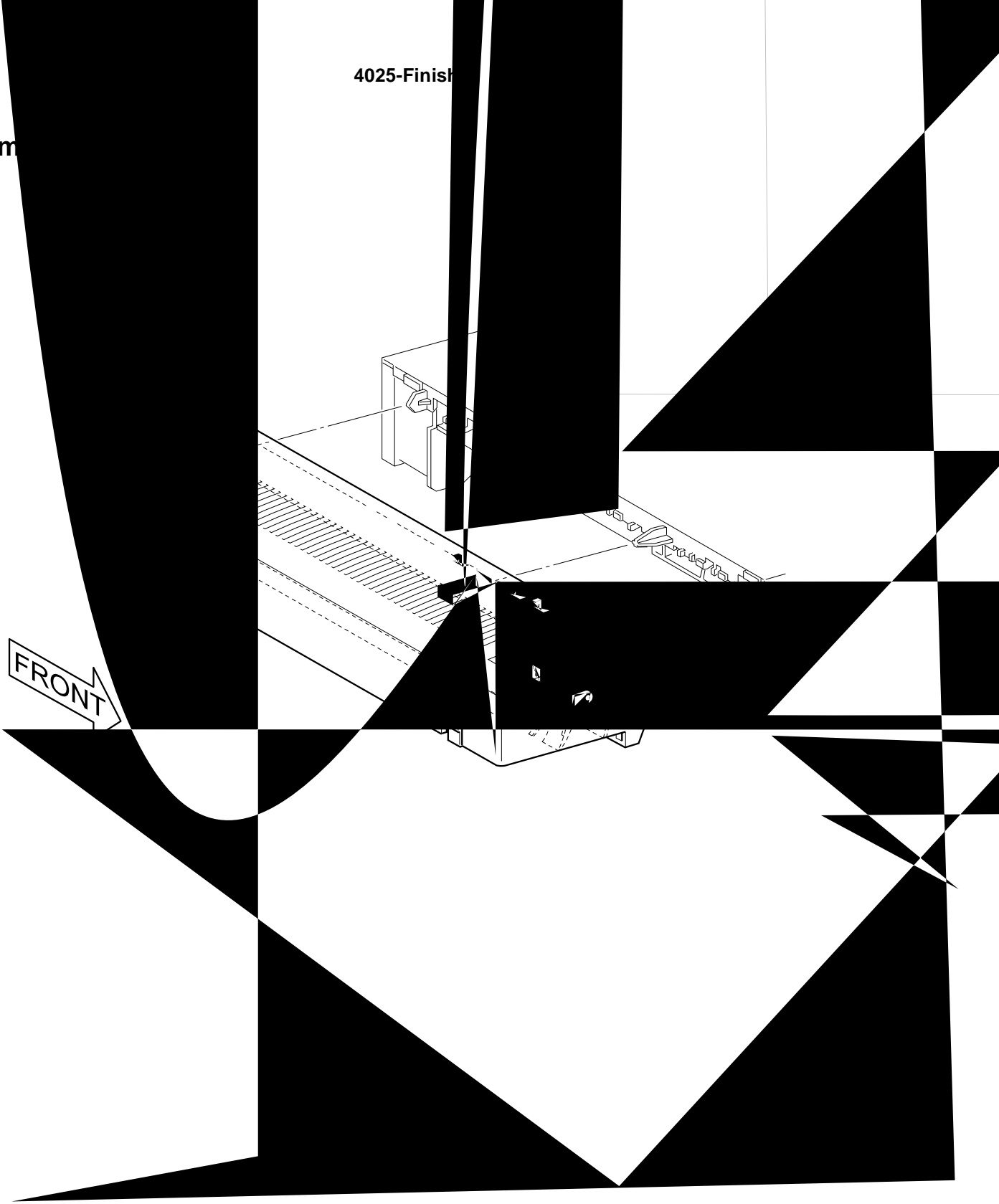



**Assembly 1: Top Cover**

<b>Ref</b>	<b>Part Number</b>	<b>Units</b>	<b>Description</b>
1-1	12G4232	1	Cover, Top

## Assembly 2: Frame Transport Assembly

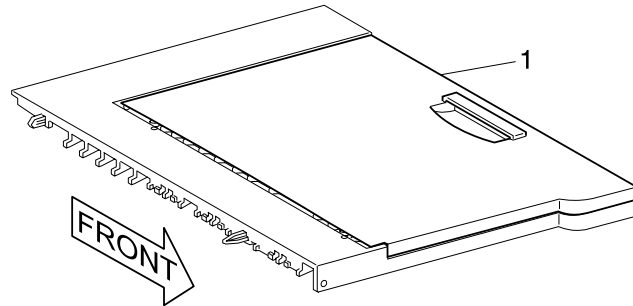

**Assembly 2: Frame Transport, Rear**

Ref	Part Number	Units	Description
2 - 1	12G4386	1	Assembly, Transport

### Assembly 3:

See Assembly 2. This page intentionally left blank.

**Assembly 3:**

Ref	Part Number	Units	Description
			<b>Note:</b> See assembly 2. The Transport assembly has been combined into one FRU.

### Assembly 4: Docking Parts, Front Cover, Top Tray

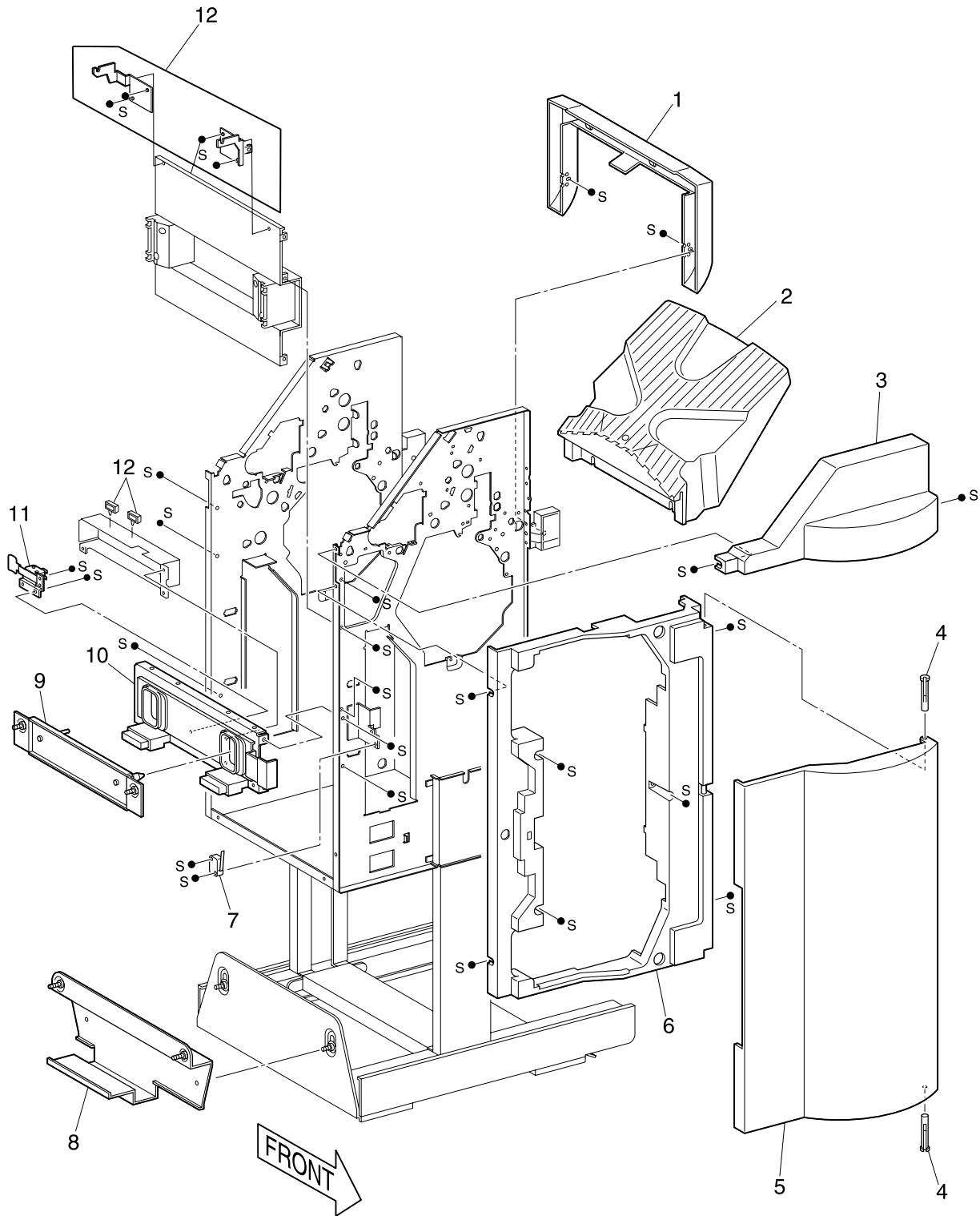

**Assembly 4: Docking Parts, Front Cover, Top Tray**

<b>Ref</b>	<b>Part Number</b>	<b>Units</b>	<b>Description</b>
4 - 1	12G4249	1	Cover, Jogging
2	12G4250	1	Tray, Lower
3	12G4251	1	Cover, Top
4	12G4260	2	Cover, Stud
5	12G4252	1	Cover, Front
6	12G4253	1	Cover, Front Mount
7	12G4254	1	Switch, Cover
8	12G4255	1	Bracket Assembly
9	12G4256	1	Bracket, Pin
10	12G4257	1	Latch Assembly
11	12G4258	1	Switch Assembly, Docking
12	12G4259	1	Bracket, Transport H

### Assembly 5: Rear Cover

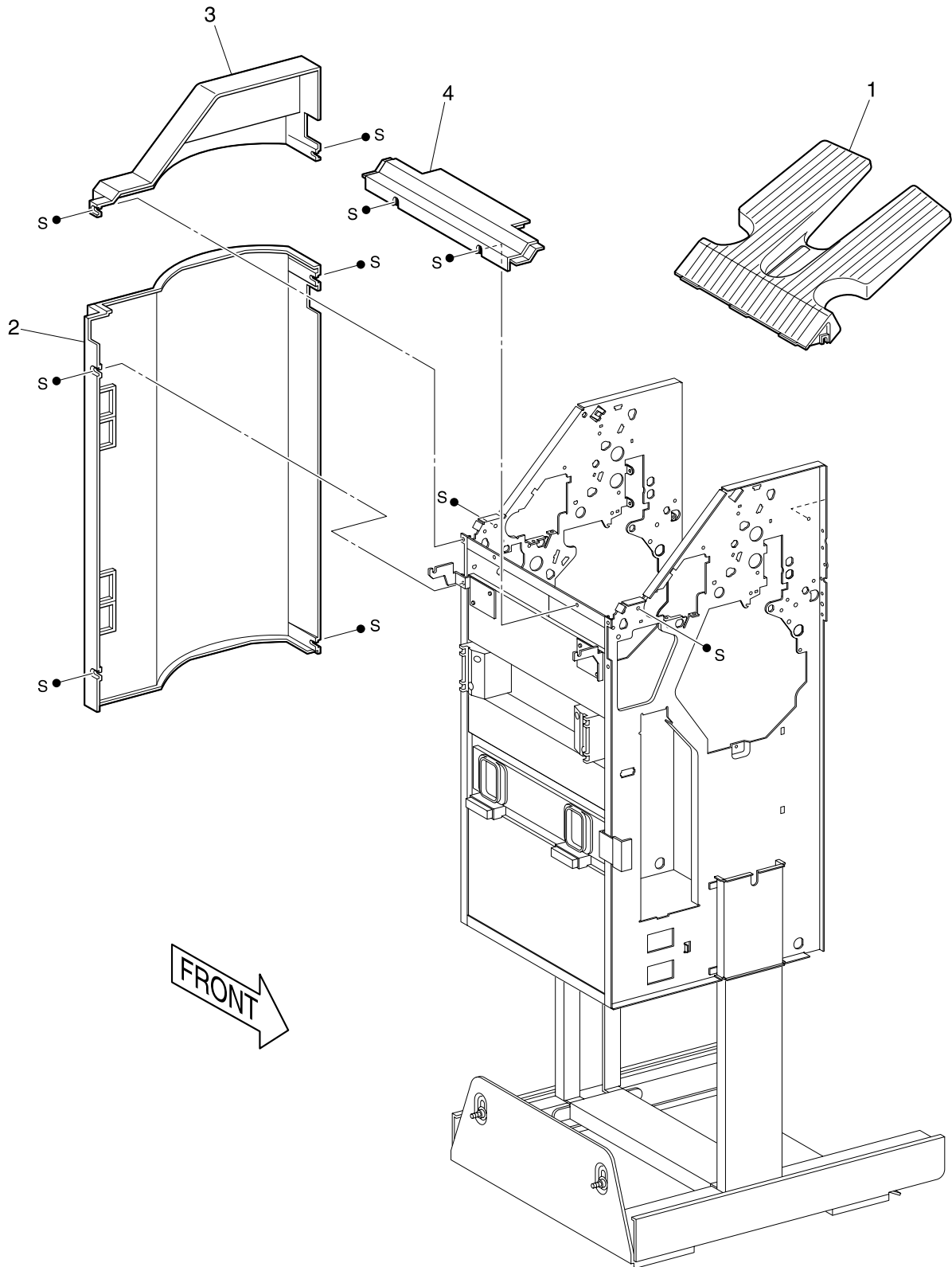



**Assembly 5: Rear Cover**

<b>Ref</b>	<b>Part Number</b>	<b>Units</b>	<b>Description</b>
5 - 1	12G4264	1	Tray, Face Up
2	12G4261	1	Cover, Rear
3	12G4262	1	Cover, Top Rear
4	12G4263	1	Cover, Top Left

Assembly 6: Chute 1

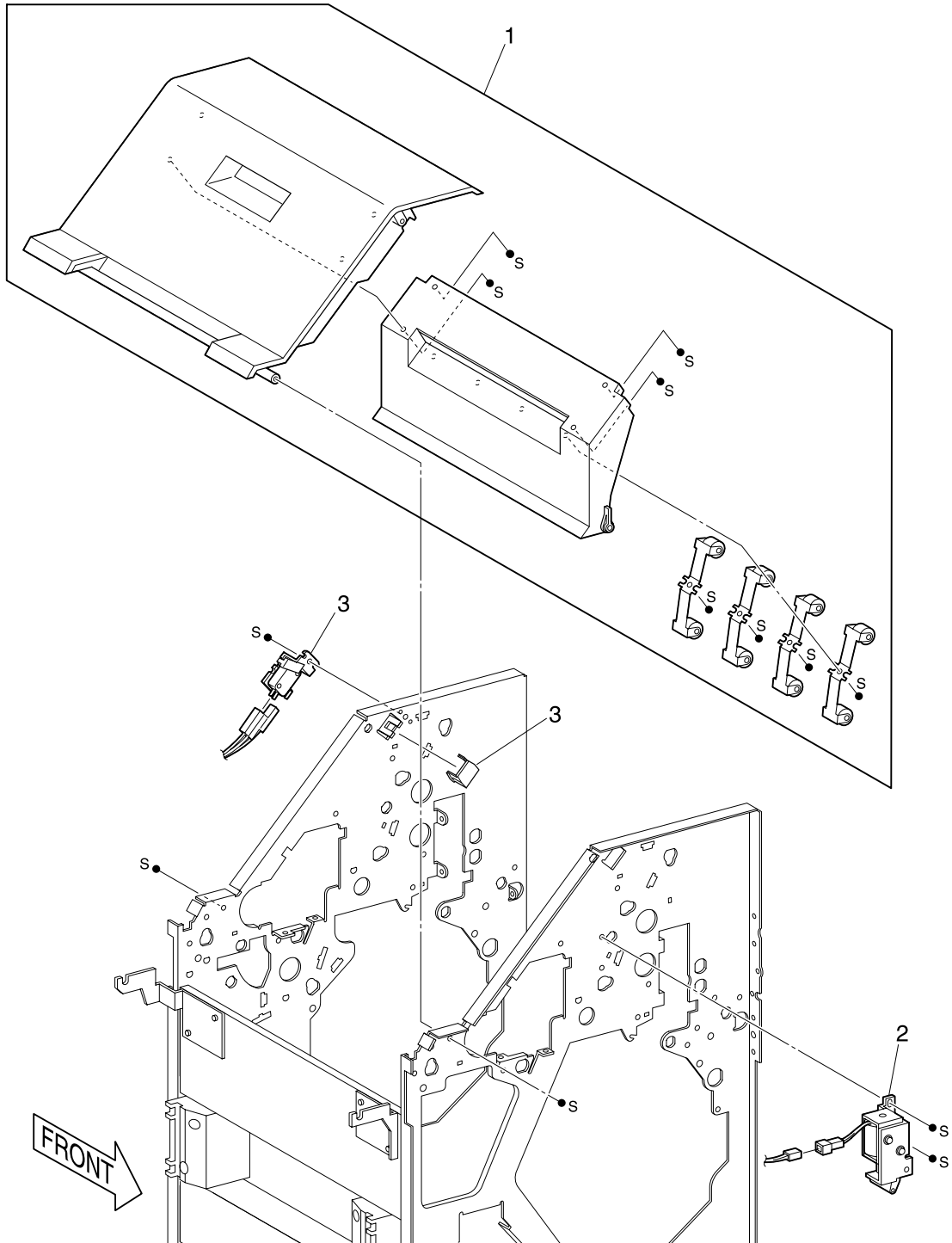

**Assembly 6: Chute 1**

<b>Ref</b>	<b>Part Number</b>	<b>Units</b>	<b>Description</b>
6 - 1	12G4267	1	Cover Assembly, Top
2	12G4265	1	Gate, Solenoid
3	12G4266	1	Switch Assembly, Finisher

### Assembly 7: Chute 2

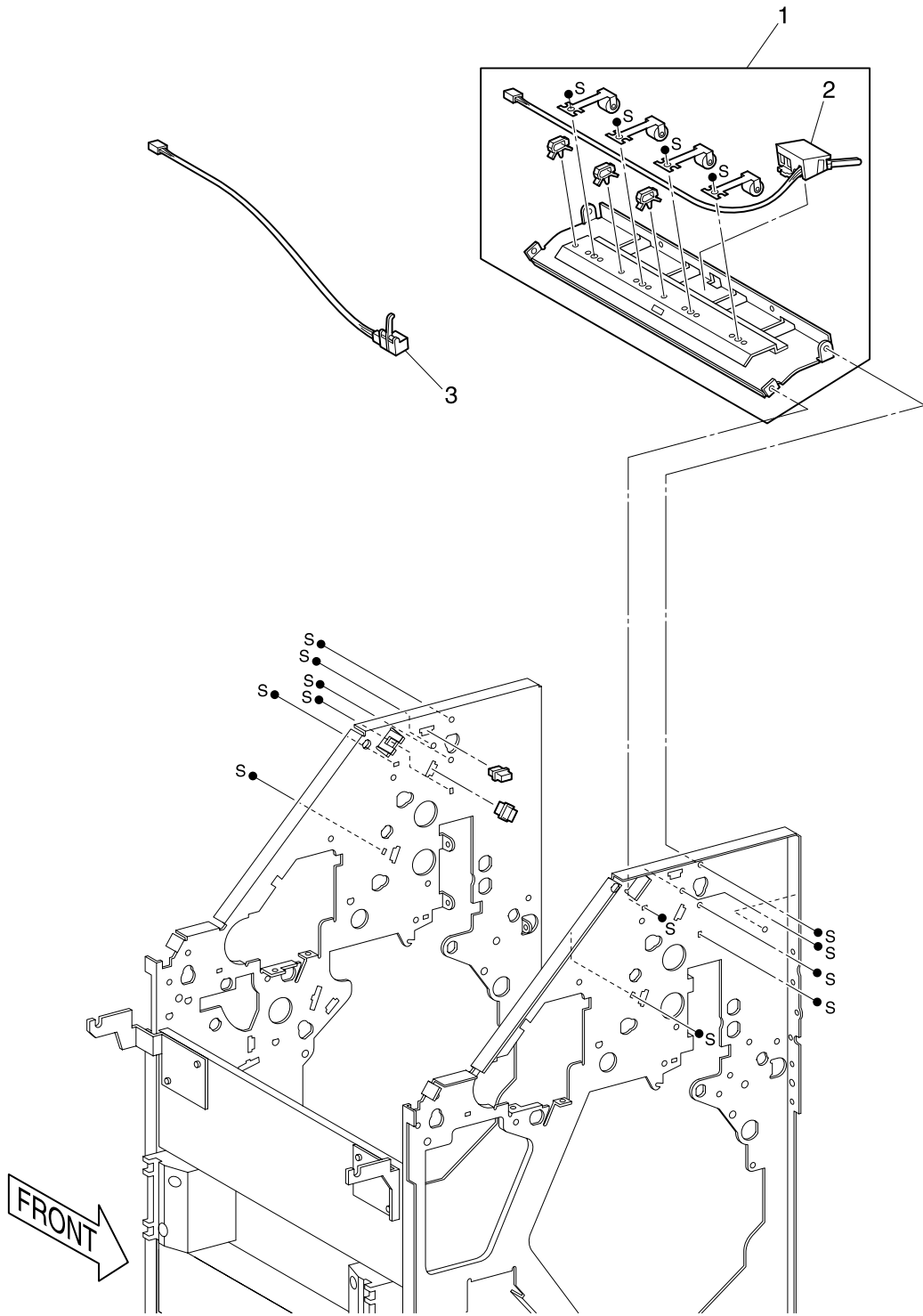

**Assembly 7: Chute 2**

<b>Ref</b>	<b>Part Number</b>	<b>Units</b>	<b>Description</b>
7 - 1	12G4270	1	Sensor, Exit BM
2	12G4268	1	Sensor, Full Stack
3	12G4269	2	Sensor, Exit

### Assembly 8: Top Exit

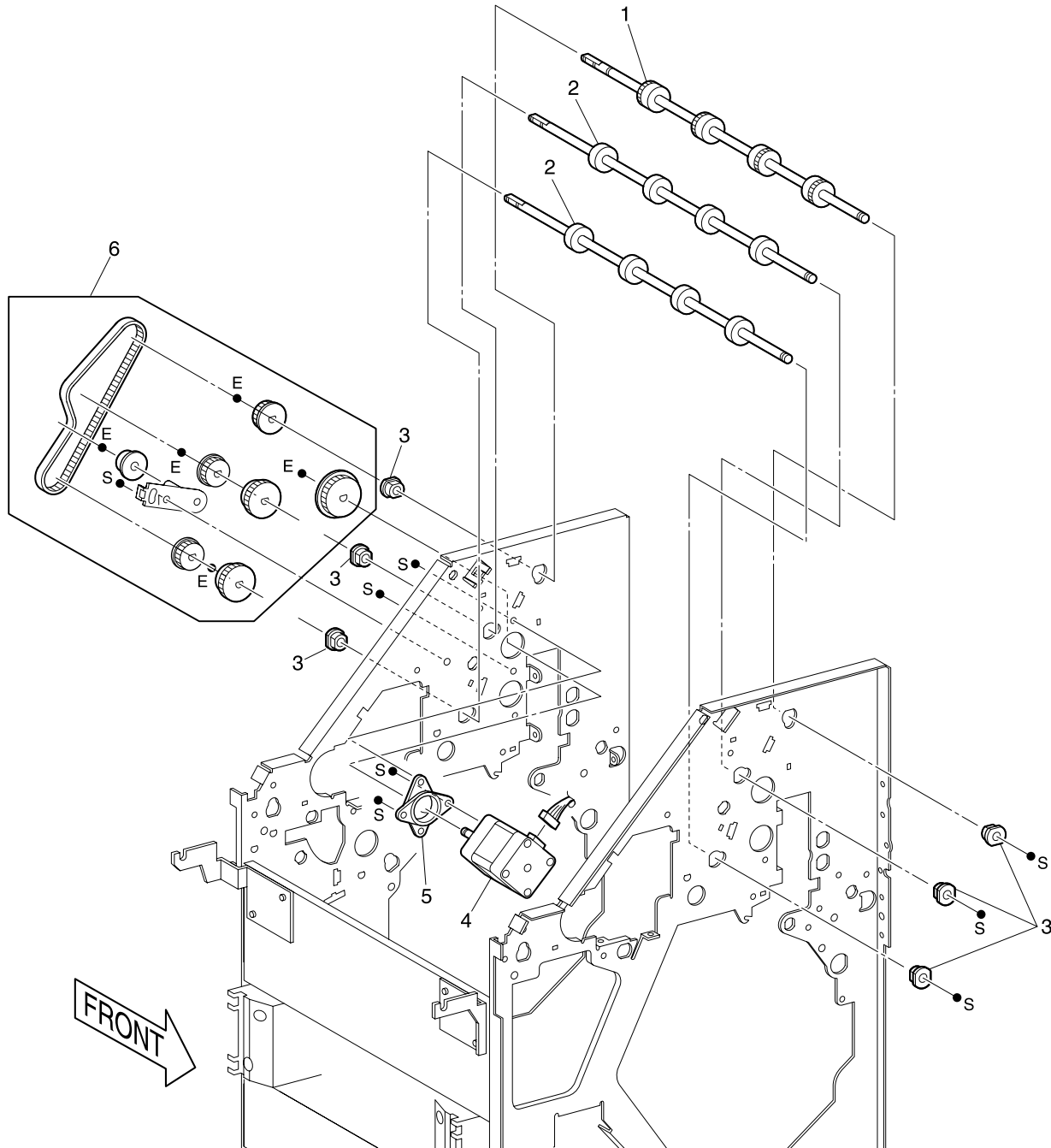

**Assembly 8: Top Exit**

<b>Ref</b>	<b>Part Number</b>	<b>Units</b>	<b>Description</b>
8 - 1	12G4271	1	Roll, Upper
2	12G4272	2	Roll, Transport
3	12G4273	6	Bearing
4	12G4274	1	Motor, Stepping
5	12G4275	1	Stop, Damper
6	12G4276	1	Kit, Gear

# Assembly 9: Frame

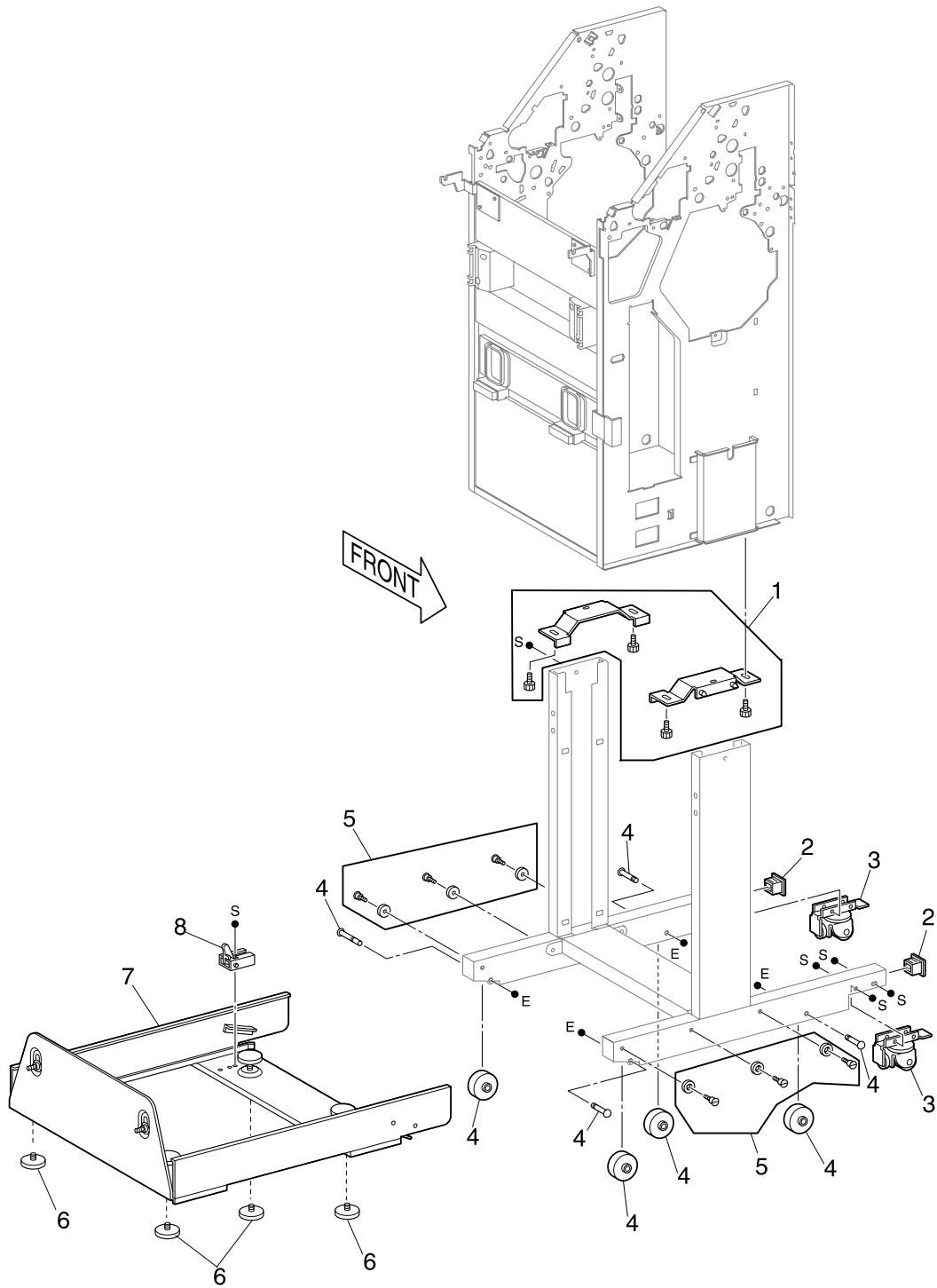



**Assembly 9: Frame**

<b>Ref</b>	<b>Part Number</b>	<b>Units</b>	<b>Description</b>
9 - 1	12G4281	1	Kit, Bracket
2	12G4277	2	Cap, End
3	12G4278	1	Caster Assembly
4	12G4284	4	Kit, Roll L
5	12G4283	1	Kit, Roll
6	12G4282	4	Foot
7	12G4280	1	Frame, Rail
8	12G4279	1	Lever Assembly

# Assembly 10: Guide

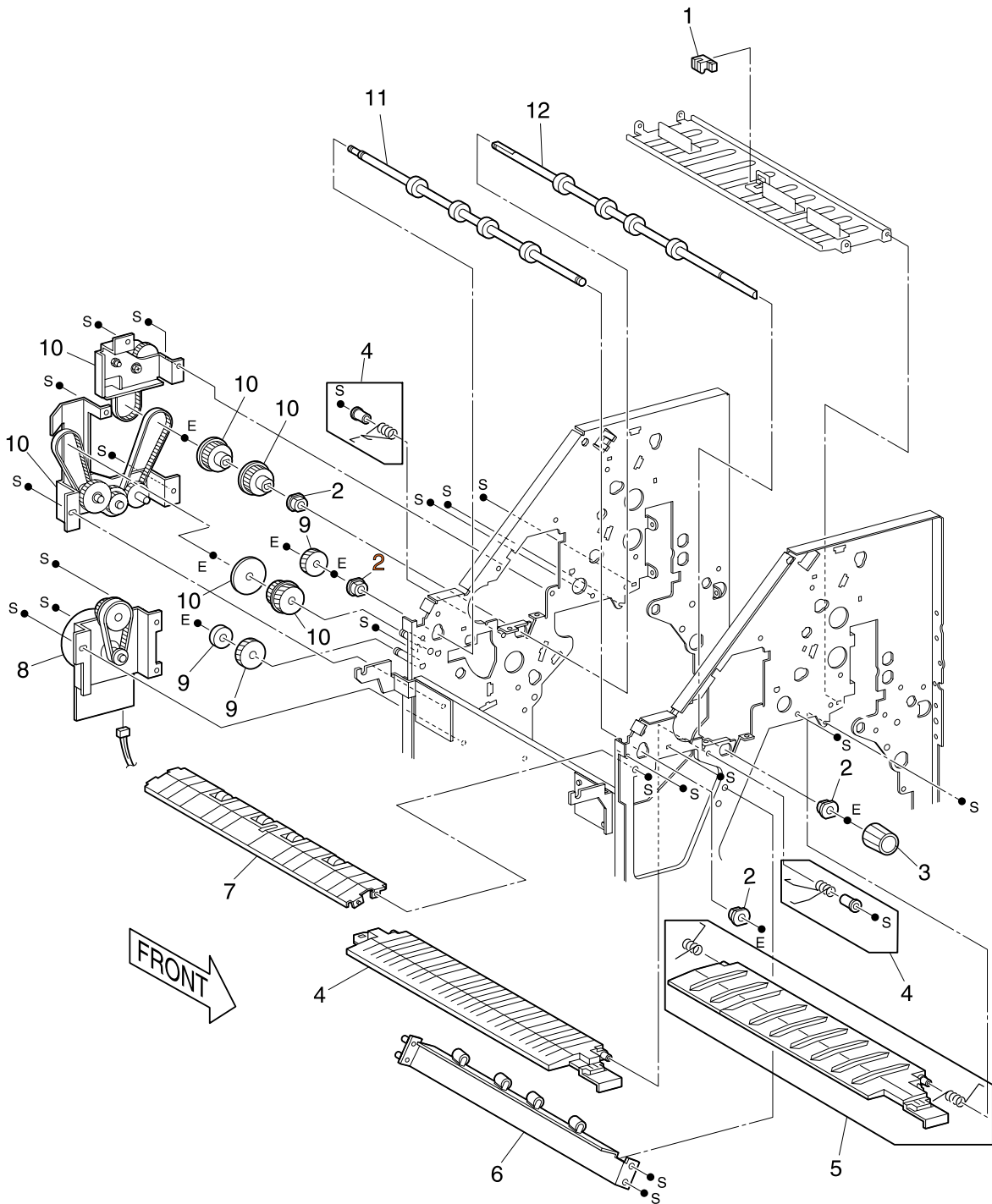

**Assembly 10: Guide**

<b>Ref</b>	<b>Part Number</b>	<b>Units</b>	<b>Description</b>
10 - 1	12G4285	1	Sensor, Guide
2	12G4288	4	Bearing, Guide
3	12G4290	1	Knob, Guide
4	12G4296	1	Inverter, Guide
5	12G4295	1	Buffer, Guide
6	12G4292	1	Blade Assembly
7	12G4289	1	Guide, In
8	12G4291	1	Motor, Transport
9	12G4293	1	Kit, Gear
10	12G4294	1	Drive Assembly
11	12G4287	1	Roll, Transport
12	12G4286	1	Roll, Registration

# Assembly 11: Puncher Assembly

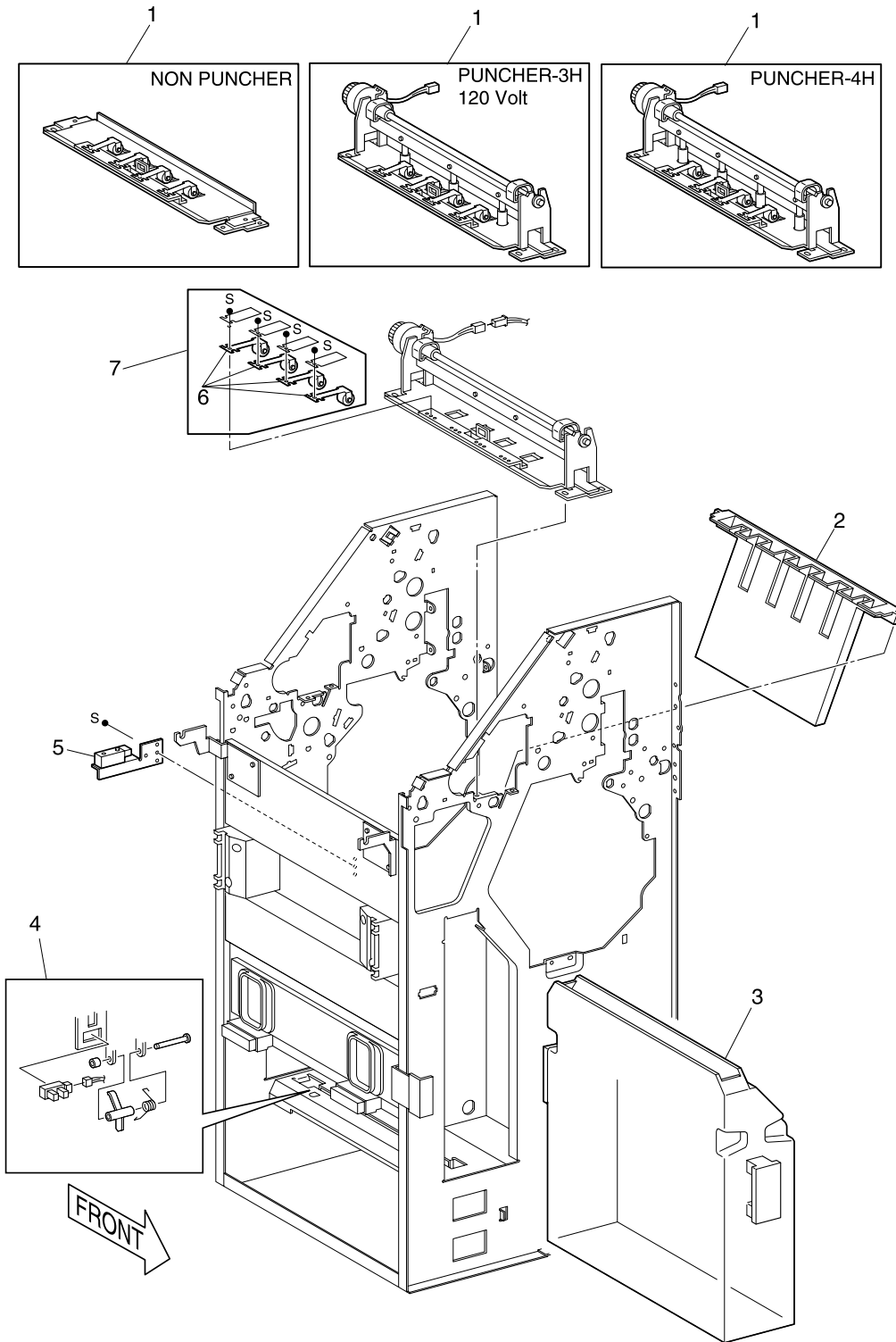

**Assembly 11: Puncher Assembly**

<b>Ref</b>	<b>Part Number</b>	<b>Units</b>	<b>Description</b>
11 - 1	12G4297	1	Punch, Non Punch
1	12G4298	1	Punch, 3 Hole
1	12G4299	1	Punch, 4 Hole
2	12G4301	1	Guide Assembly
3	12G4302	1	Bottle, Paper
4	12G4305	1	Sensor, Bottle
5	12G4303	1	Sensor Assembly
6	12G4300	1	Roll, Pinch
7	12G4304	1	Feed Assembly

### Assembly 12: Jogging Assembly

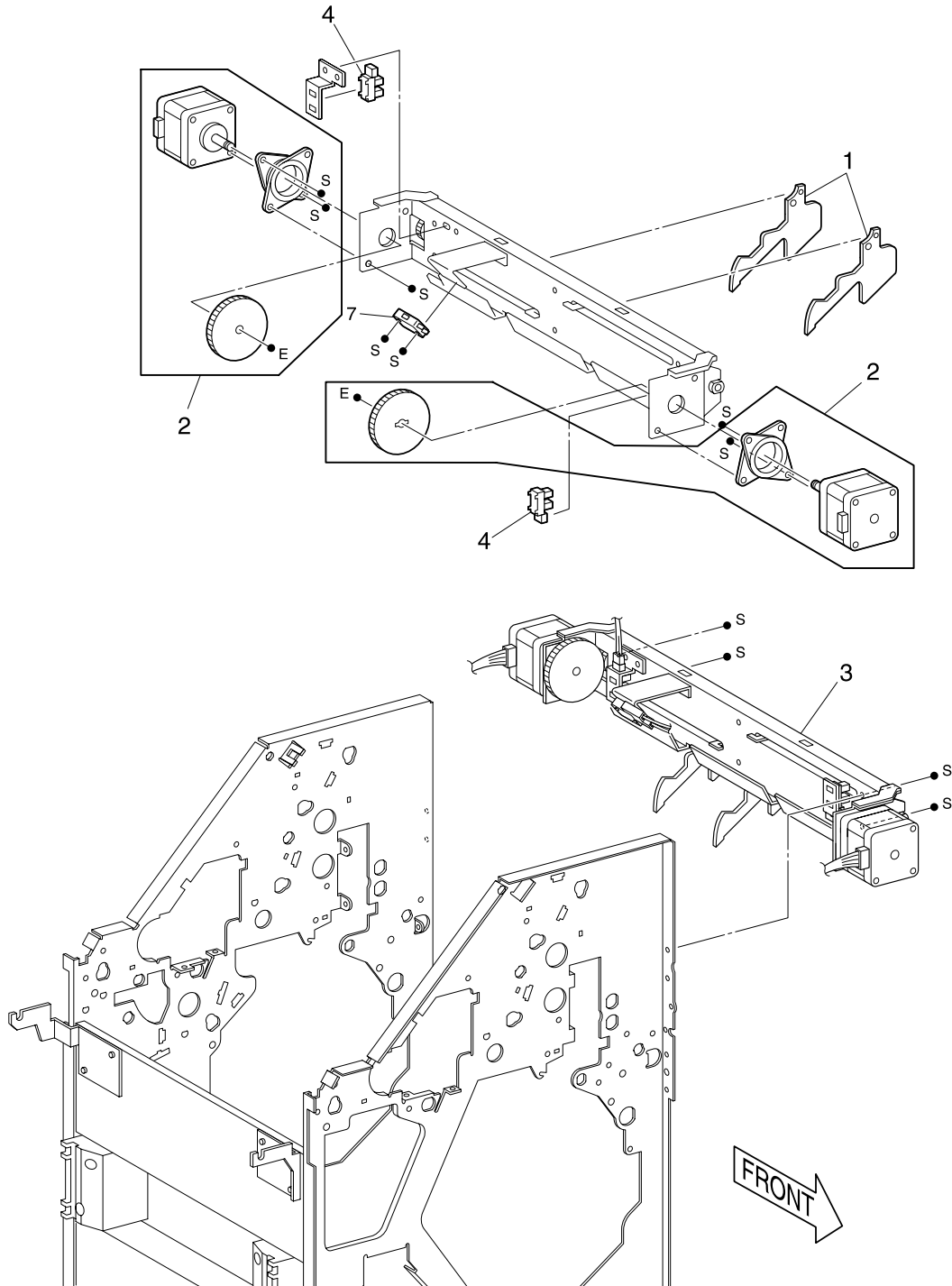

**Assembly 12: Jogging Assembly**

<b>Ref</b>	<b>Part Number</b>	<b>Units</b>	<b>Description</b>
12 - 1	12G4307	1	Paddle, Paper
2	12G4309	1	Motor, Jogging
3	12G4308	1	Jogging Assembly
4	12G4306	2	Sensor, Jogging

### Assembly 13: Shift Assembly

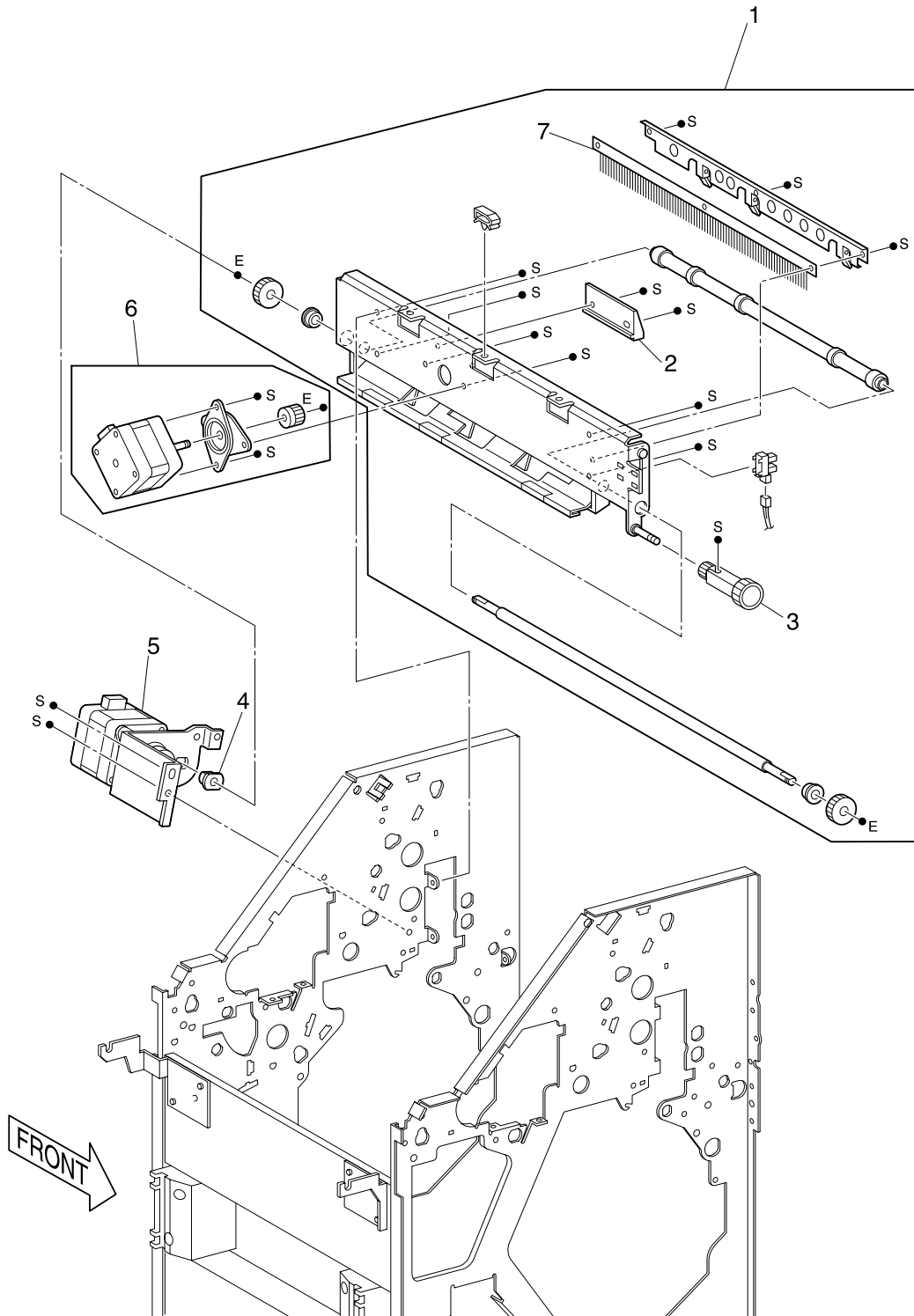



**Assembly 13: Shift Assembly**

<b>Ref</b>	<b>Part Number</b>	<b>Units</b>	<b>Description</b>
13 - 1	12G4315	1	Shift Kit Assembly
2	12G4313	1	Rack, Gear
3	12G4312	1	Knob, Shift Assembly
4	12G4311	1	Bearing, Shift Assembly
5	12G4310	1	Motor, MP2
6	12G4316	1	Motor Assembly, Shift Kit
7	12G4314	1	Eliminator

# Assembly 14: Stacker Unit

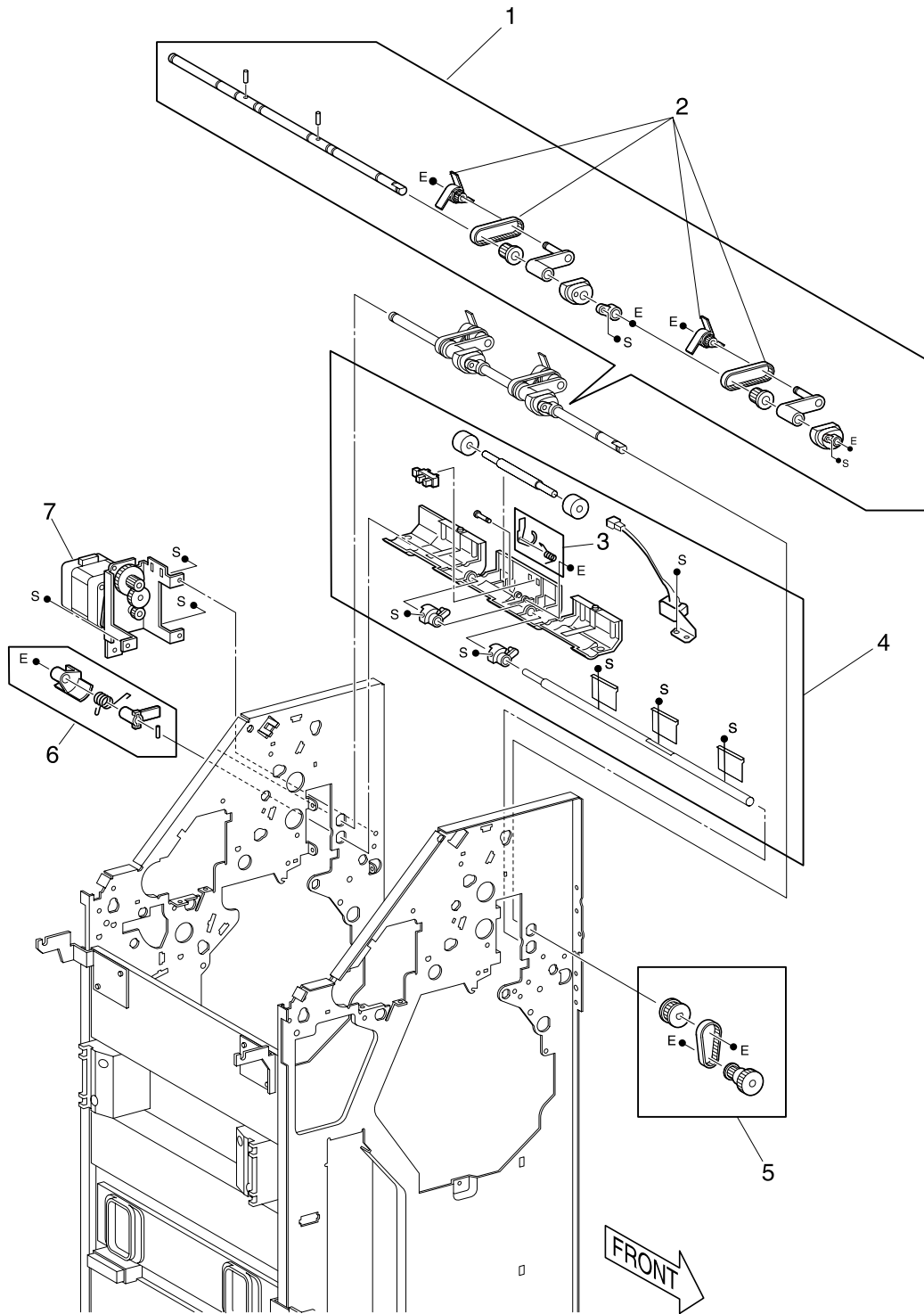

**Assembly 14: Stacker Unit**

<b>Ref</b>	<b>Part Number</b>	<b>Units</b>	<b>Description</b>
14 - 1	12G4318	1	Shaft Assembly, Paddle
2	12G4321	1	Paddle Assembly
3	12G4319	1	Exit Assembly, Actuator
4	12G4320	1	Kit Assembly, Compiler Guide
5	12G4322	1	Gear, Front
6	12G4323	1	Gear, Rear
7	12G4317	1	Motor, MP4

# Assembly 15: Stacker Tray

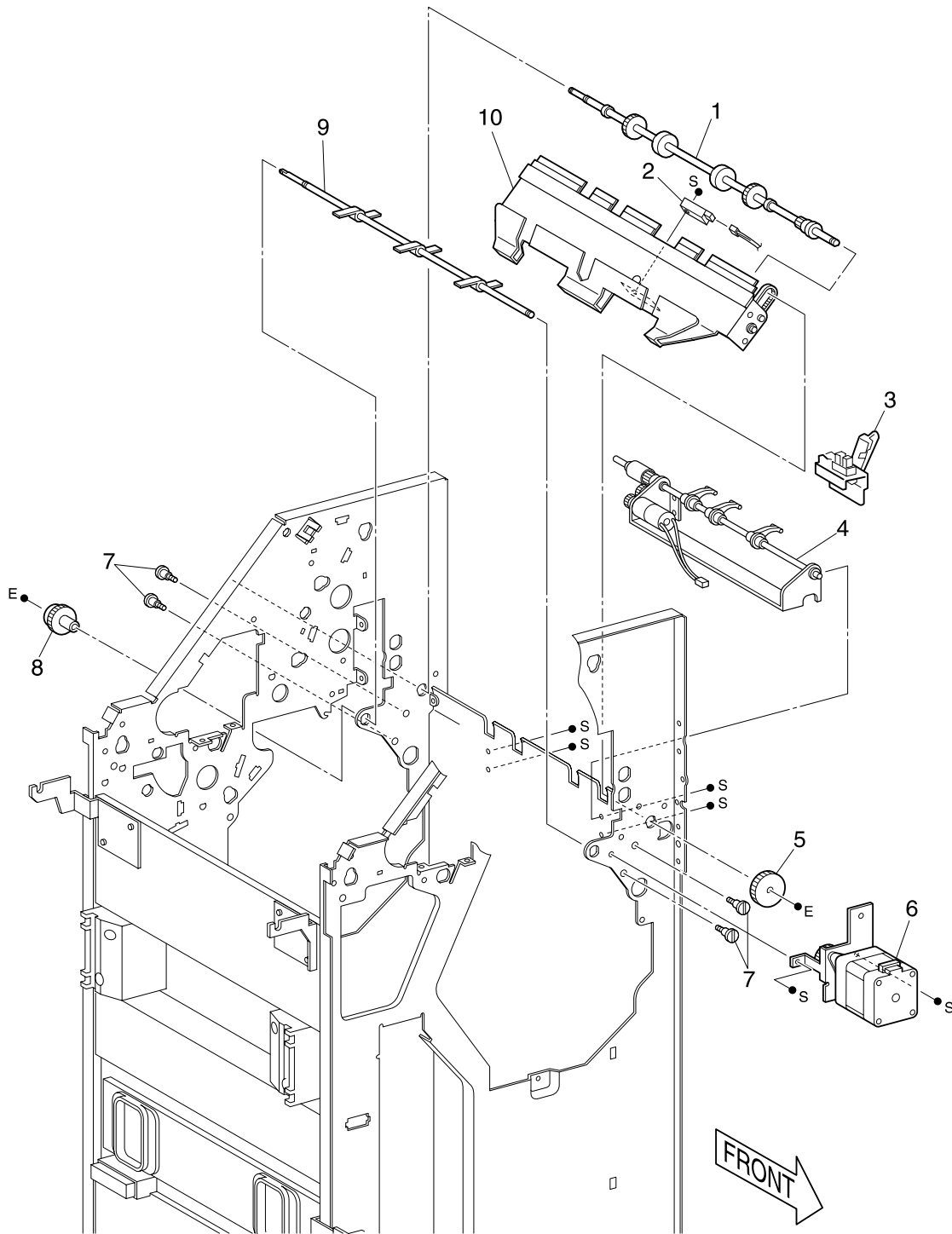

**Assembly 15: Stacker Tray**

<b>Ref</b>	<b>Part Number</b>	<b>Units</b>	<b>Description</b>
15 - 1	12G4327	1	Roll, Stack
2	12G4331	1	Sensor, No Paper Stapler
3	12G4332	1	Sensor, Lower Tray
4	12G4330	1	Stack Assembly
5	12G4324	1	Gear
6	12G4328	1	Motor, Stacker
7	12G4333	1	Kit, Shoulder Assembly
8	12G4329	1	Pulley, Stacker
9	12G4325	1	Roll, Paddle Assembly
10	12G4326	1	Staple Assembly

# Assembly 16: Stapler Assembly

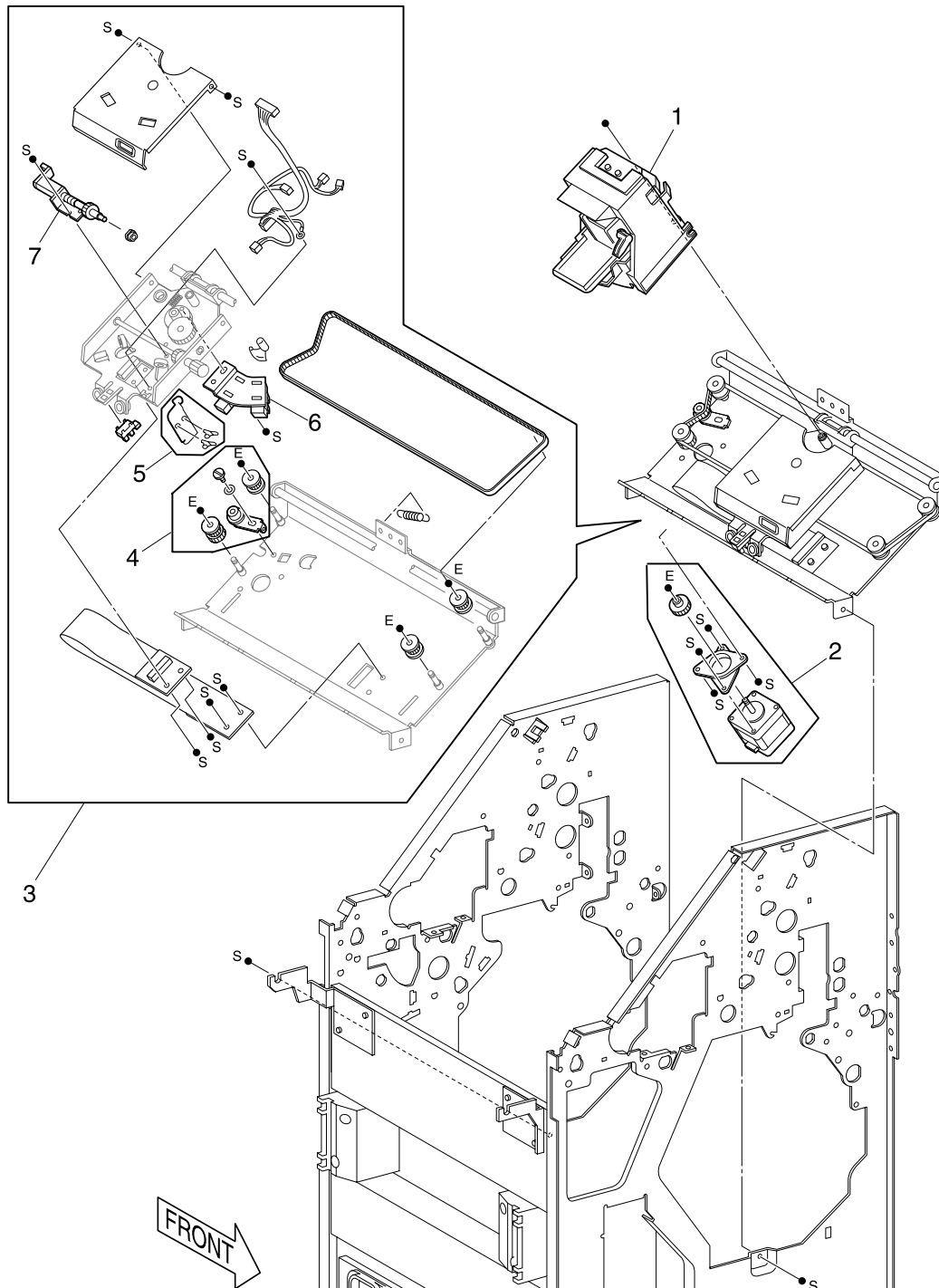

**Assembly 16: Stapler Assembly**

<b>Ref</b>	<b>Part Number</b>	<b>Units</b>	<b>Description</b>
16 - 1	12G4334	1	Stapler Assembly
2	12G4339	1	Motor Assembly, Traverse
3	12G4337	1	Base Assembly, Stapler
4	12G4340	1	Pulley, Stapler
5	12G4338	1	Kit, Secure Plate
6	12G4336	1	Sensor Assembly, Swing
7	12G4335	1	Motor Assembly, Swing

# Assembly 17: Elevator Unit

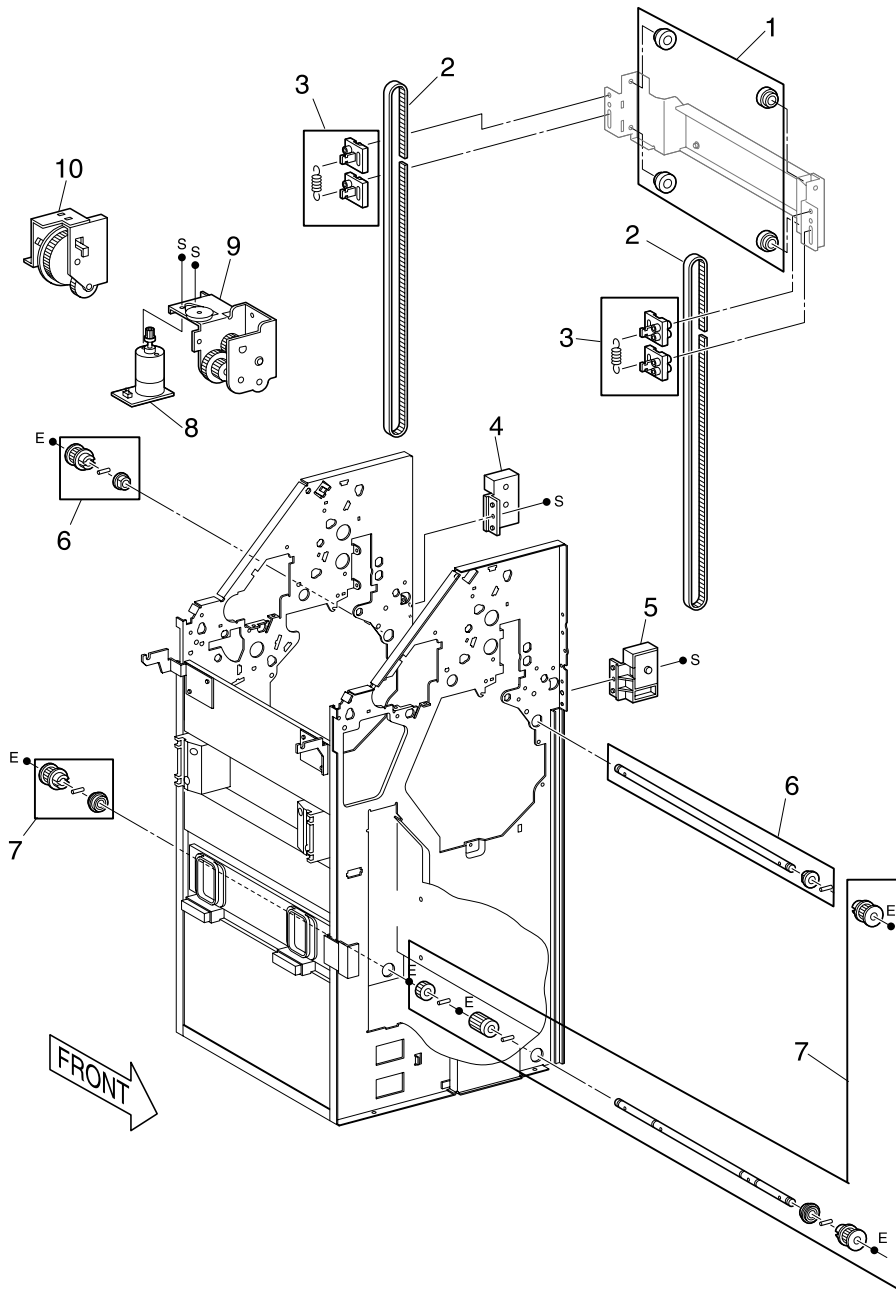



**Assembly 17: Elevator Unit**

<b>Ref</b>	<b>Part Number</b>	<b>Units</b>	<b>Description</b>
17 - 1	12G4347	1	Kit, Bearing
2	12G4341	2	Belt, Elevator Unit
3	12G4349	1	Holder Assembly
4	12G4346	1	Sensor, Tray Height Rear
5	12G4342	1	Sensor, Tray Height
6	12G4350	1	Shaft Assembly, Elevator U
7	12G4348	1	Shaft Assembly
8	12G4344	1	Motor, MD11
9	12G4343	1	Drive Assembly, Elevator
10	12G4345	1	Encoder Assembly

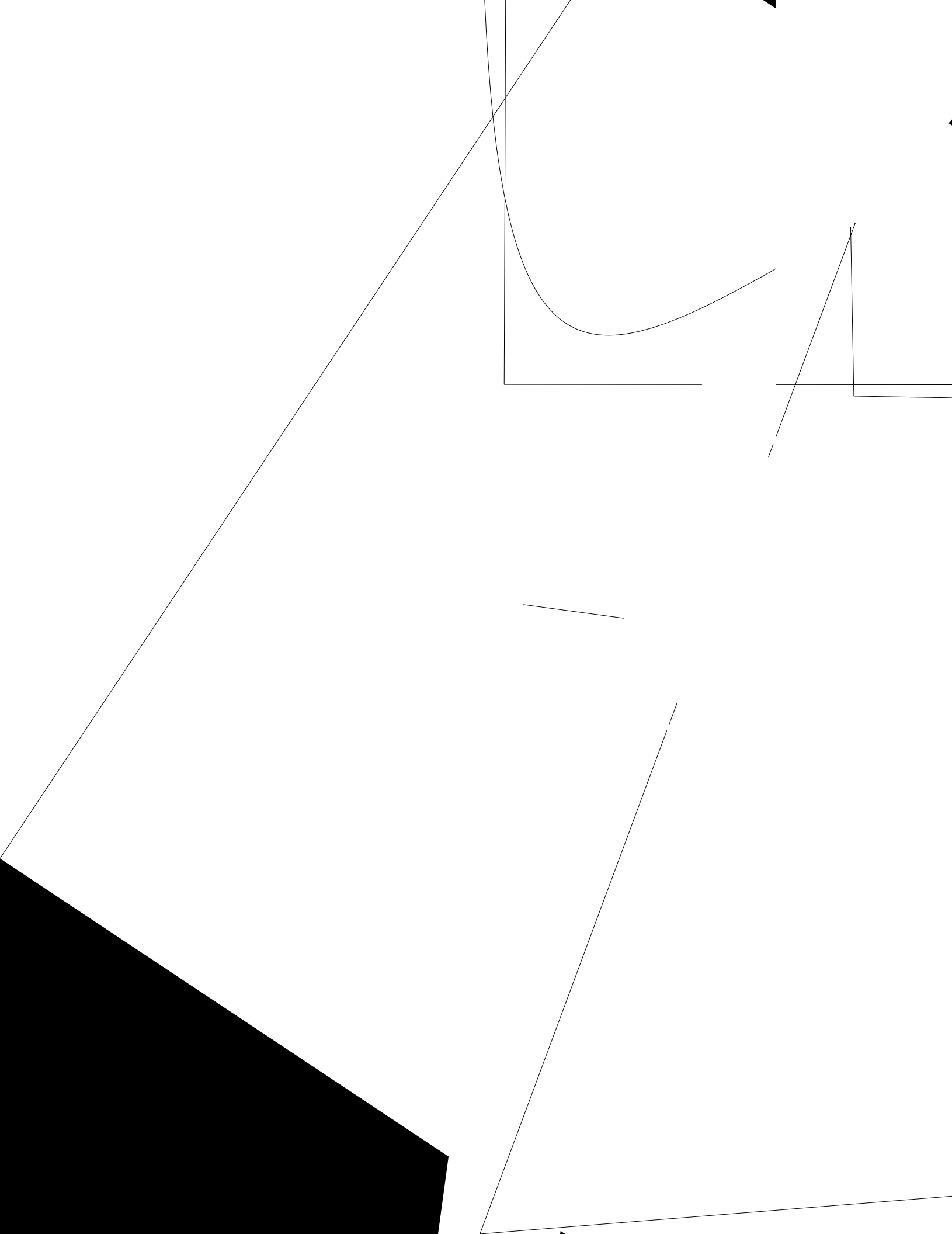

**Assembly 18: Finisher Main PWB, Power Supply**

<b>Ref</b>	<b>Part Number</b>	<b>Units</b>	<b>Description</b>
18 - 1	12G4354	1	Cord, Power
2	12G4351	1	Power Supply, Finisher
3	12G4353	1	Cable, I/F
4	12G4352	1	Card, Finisher
NS		1	Kit, Rivet

# Assembly 19: Harness

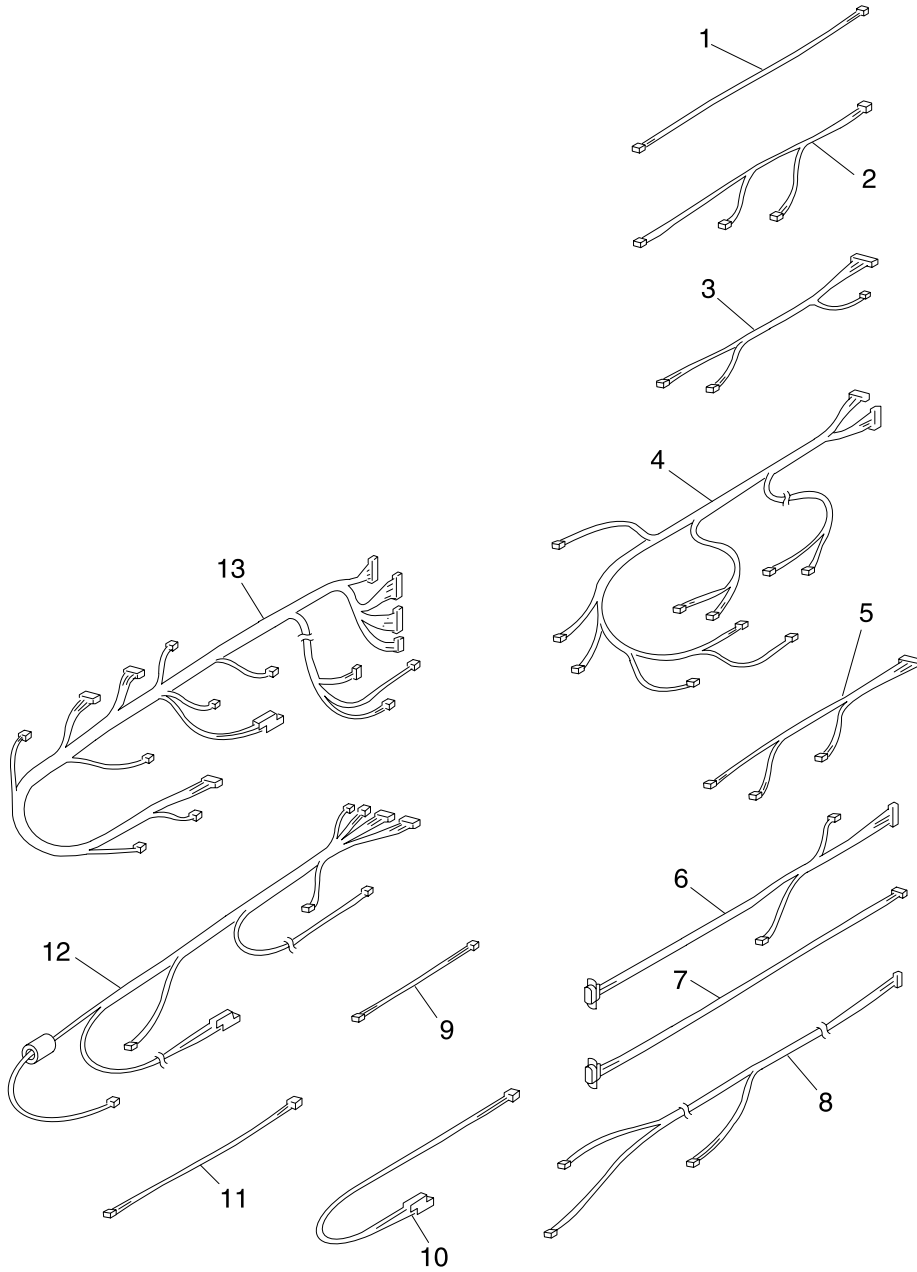

**Assembly 19: Harness**

<b>Ref</b>	<b>Part Number</b>	<b>Units</b>	<b>Description</b>
19 - 1	12G4355	1	Harness, No Paper
2	12G4356	1	Harness, Encoder
3	12G4357	1	Harness, Stapler (Middle)
4	12G4358	1	Harness, Sensor
5	12G4359	1	Harness, Middle 1
6	12G4360	1	Harness, H Tray
7	12G4361	1	Harness, I/F
8	12G4362	1	Harness, Face Up
9	12G4363	1	Harness, Exit
10	12G4364	1	Harness, Docking
11	12G4365	1	Harness, Middle 2
12	12G4366	1	Harness, DC
13	12G4367	1	Harness, Motor

## 4025-Finisher

# Index

## A

Attendance Message Table **2-5**

## C

Caution Labels **1-3**

Caution Notice **1-1**

Compiler & Jogger Section **1-33**

Connectors **5-1**

## D

Diagnostic Aids **3-1**

Analyzing Test Print **3-1**

Finisher Sensor Test **3-2**

Finisher Tests **3-2**

Staple Test **3-2**

Using Test Print **3-1**

Diagnostics

Attendance Message Table **2-5**

Control Panel Messages **2-1**

    Accessing Additional Debug Information **2-3**

    Attendance Messages **2-2**

    Service Messages **2-2**

    Status Messages **2-2**

    Status Screens **2-1**

Service Checks Flowchart **2-9**

Service Error Code Table **2-4**

## E

Entering Diagnostic Mode **3-1**

Exit Sections **1-37**

Exiting Diagnostic Mode **3-1**

## F

Finisher Control **1-5**

Finisher Paper Path **1-26**

Finisher Power **1-4**

Finisher Tests

    Sensor Test **3-2**

    Staple Test **3-2**

## G

General Information

Glossary **1-44**

Safety Details

    Caution Labels **1-3**

    Fuser Components **1-3**

    Laser Components **1-2**

    Mechanical Components **1-2**

Power Supply/Electrical Components **1-2**

Glossary **1-44**

    Abbreviations **1-44**

    Acronyms **1-44**

    Terms **1-44**

## H

H-Tra Section **1-27**

## I

Introduction **1-1**

## L

Location Map 1 **5-6**

Location Map 2 **5-7**

Location Map 3 **5-8**

Location Map 4 **5-9**

Location Map 5 **5-10**

Location Map 6 **5-11**

Location Table **5-2**

## M

Maintenance, Scheduled **6-1**

Mechanical Drive **1-7**

## P

Paper Stack Sections **1-39**

Principles of Operation **1-4**

Punch Section **1-28**

## R

Removal and Replacement Procedures **4-1**

Removals

    Belt **4-110**

    Belt-Sync Removal **4-5**

    Blade Assembly **4-118**

    Bottle Assembly-Dust **4-60**

    Bracket Assembly **4-6**

    Cable, Flat **4-111**

    Cap-End **4-38**

    Cartridge **4-101**

    Caster Assembly **4-39**

    Chute Assembly-Inlet **4-48**

    Compiler Roll and Roll Shaft **4-80**

    Cover Top H-Tra Assembly **4-13**

    Cover Top Left **4-33**

    Cover-Jogging **4-23**

    Cover-Open, Cover-Front and Kit Stud Cover **4-26**

Cover-Rear **4-32**  
 Cover-Top, Front and Rear **4-25**  
 Drive Assembly-ELEV, Motor Assembly-MD11  
     **4-124**  
 Encoder Assembly **4-128**  
 Entrance Roll **4-16**  
 Exit Assembly **4-145**  
 Exit Roll Sensor **4-82**  
 Exit Sensor **4-143**  
 Face Up Tray **4-138**  
 Frame Post **4-36**  
 Full Stack Sensor Assembly **4-141**  
 Gate Solenoid **4-140**  
 Gear Kit **4-150**  
 Guide Assembly-Dust **4-59**  
 Holder Assembly **4-116**  
 Inner Cover **4-62**  
 Kit Bearing **4-114**  
 Kit Bracket Assembly and Screw **4-35**  
 Kit Buffer Chute **4-51**  
 Kit Drive Assembly **4-46**  
 Kit Gear Front **4-83**  
 Kit Gear Rear **4-85**  
 Kit H-Tra Bracket and Screw **4-31**  
 Kit Invert Guide **4-49**  
 Kit Motor Jogging **4-66**  
 Kit Roll Pinch **4-57**  
 Kit Shift Assembly **4-71**  
 Kit Shift Motor **4-76**  
 Knob, Regi Roller **4-53**  
 Knob, Shift Unit **4-75**  
 Latch Assembly and Switch Docking **4-29**  
 Lever Assembly **4-40**  
 Motor **4-84**  
 Motor Assembly-MP2 **4-77**  
 Motor Assembly-MP4 **4-87**  
 Motor Assembly-Swing **4-104**  
 No Paper Sensor Assembly **4-136**  
 Pinch Roll II **4-142**  
 Plate-Jogger **4-70**  
 Port Harness Assembly **4-135**  
 Power Supply **4-130**  
 Puncher **4-55**  
 PWB Assembly-Main **4-132**  
 Rear Cover **4-2**  
 Right Cover **4-126**  
 Roll Assembly-REGI **4-43**  
 Roll Transport **4-44**  
 Roll Transport and Aligner Roll Kit **4-14**  
 Sensor and Sensor Full **4-18**  
 Sensor Assembly Swing **4-106**  
 Sensor Bottle Kit **4-64**  
 Sensor Dust-Assembly **4-61**  
 Sensor Tray Height Front **4-119**

Sensor,  
     Path **4-58**  
 Sensor, Exit Path **4-42, 4-79**  
 Sensor, Exit Roller Open/Close Home Position  
     **4-81**  
 Sensor, Input Path **4-41**  
 Sensor, Jogger Home Position **4-68**  
 Sensor, Stapler Home Position Traverse **4-113**  
 Sensors **4-20**  
 Shaft Assembly ELEV L **4-121**  
 Shaft Assembly ELEV U **4-120**  
 Shaft Transport **4-22**  
 Solenoid Assembly-Gate In **4-11**  
 Spring Tension 80, Sensor and Harness Earth  
     **4-3**  
 Stack Arm Assembly, No Paper Sensor Tray  
     Lower **4-90**  
 Staple Stage Assembly, Stack Roll Shaft, No Pa-  
     per Sensor Stapler **4-88**  
 Stapler Harness Assembly **4-98**  
 Stapler I Assembly **4-92**  
 Stapler II Assembly **4-97**  
 Stepping Motor, Upper Tray **4-149**  
 Switch Cover Front **4-28**  
 Top Center Cover Assembly **4-34**  
 Top Cover Interlock Switch **4-139**  
 Transport Gear Kit **4-9**  
 Transport Motor Assembly **4-54**  
 Traverse Motor Assembly **4-102**  
 Tray Harness Assembly **4-7**  
 Tray-Lower **4-24**  
 Upper Roll and Roll Transport **4-147**

## S

Safety Details  
     Caution Labels **1-3**  
     Fuser Components **1-3**  
     Laser Components **1-2**  
     Mechanical Components **1-2**  
     Power Supply/Electrical Components **1-2**  
     Safety Components **1-3**  
 Safety Information **x**  
 Safety Inspection Guide **6-1**  
 Scheduled Maintenance **6-1**  
 Service Checks Flowchart **2-9**  
 Service Error Code Table **2-4**  
 Service Messages **2-2**  
 Shift Section **1-32**  
 Staple Section **1-36**  
 Start **2-1**  
 Status Messages **2-2**  
 Symbols **1-1**



**T**

Top Tray Exit Sections **1-43**

**W**

Warning Notice **1-1**

Wiring Diagram Notations **5-12**

**Part Numbers**

12G4232 **7-3**  
 12G4249 **7-9**  
 12G4250 **7-9**  
 12G4251 **7-9**  
 12G4252 **7-9**  
 12G4253 **7-9**  
 12G4254 **7-9**  
 12G4255 **7-9**  
 12G4256 **7-9**  
 12G4257 **7-9**  
 12G4258 **7-9**  
 12G4259 **7-9**  
 12G4260 **7-9**  
 12G4261 **7-11**  
 12G4262 **7-11**  
 12G4263 **7-11**  
 12G4264 **7-11**  
 12G4265 **7-13**  
 12G4266 **7-13**  
 12G4267 **7-13**  
 12G4268 **7-15**  
 12G4269 **7-15**  
 12G4270 **7-15**  
 12G4271 **7-17**  
 12G4272 **7-17**  
 12G4273 **7-17**  
 12G4274 **7-17**  
 12G4275 **7-17**  
 12G4276 **7-17**  
 12G4277 **7-19**  
 12G4278 **7-19**  
 12G4279 **7-19**  
 12G4280 **7-19**  
 12G4281 **7-19**  
 12G4282 **7-19**  
 12G4283 **7-19**  
 12G4284 **7-19**  
 12G4285 **7-21**  
 12G4286 **7-21**  
 12G4287 **7-21**  
 12G4288 **7-21**  
 12G4289 **7-21**  
 12G4290 **7-21**  
 12G4291 **7-21**  
 12G4292 **7-21**

12G4293 **7-21**  
 12G4294 **7-21**  
 12G4295 **7-21**  
 12G4296 **7-21**  
 12G4297 **7-23**  
 12G4298 **7-23**  
 12G4299 **7-23**  
 12G4300 **7-23**  
 12G4301 **7-23**  
 12G4302 **7-23**  
 12G4303 **7-23**  
 12G4304 **7-23**  
 12G4305 **7-23**  
 12G4306 **7-25**  
 12G4307 **7-25**  
 12G4308 **7-25**  
 12G4309 **7-25**  
 12G4310 **7-27**  
 12G4311 **7-27**  
 12G4312 **7-27**  
 12G4313 **7-27**  
 12G4314 **7-27**  
 12G4315 **7-27**  
 12G4316 **7-27**  
 12G4317 **7-29**  
 12G4318 **7-29**  
 12G4319 **7-29**  
 12G4320 **7-29**  
 12G4321 **7-29**  
 12G4322 **7-29**  
 12G4323 **7-29**  
 12G4324 **7-31**  
 12G4325 **7-31**  
 12G4326 **7-31**  
 12G4327 **7-31**  
 12G4328 **7-31**  
 12G4329 **7-31**  
 12G4330 **7-31**  
 12G4331 **7-31**  
 12G4332 **7-31**  
 12G4333 **7-31**  
 12G4334 **7-33**  
 12G4335 **7-33**  
 12G4336 **7-33**  
 12G4337 **7-33**  
 12G4338 **7-33**  
 12G4339 **7-33**  
 12G4340 **7-33**  
 12G4341 **7-35**  
 12G4342 **7-35**  
 12G4343 **7-35**  
 12G4344 **7-35**  
 12G4345 **7-35**  
 12G4346 **7-35**

12G4347 **7-35**  
12G4348 **7-35**  
12G4349 **7-35**  
12G4350 **7-35**  
12G4351 **7-37**  
12G4352 **7-37**  
12G4353 **7-37**  
12G4354 **7-37**  
12G4355 **7-39**  
12G4356 **7-39**  
12G4357 **7-39**  
12G4358 **7-39**  
12G4359 **7-39**  
12G4360 **7-39**  
12G4361 **7-39**  
12G4362 **7-39**  
12G4363 **7-39**  
12G4364 **7-39**  
12G4365 **7-39**  
12G4366 **7-39**  
12G4367 **7-39**  
12G4386 **7-5**