



Service Manual

Lexmark C91x

5055-xxx

- ***Table of Contents***
- ***Start Diagnostics***
- ***Safety and Notices***
- ***Trademarks***
- ***Index***

LEXMARK[™]

Lexmark and Lexmark with diamond design are trademarks of Lexmark International, Inc., registered in the United States and/or other countries.

Edition: October 2004

The following paragraph does not apply to any country where such provisions are inconsistent with local law: LEXMARK INTERNATIONAL, INC. PROVIDES THIS PUBLICATION "AS IS" WITHOUT WARRANTY OF ANY KIND, EITHER EXPRESS OR IMPLIED, INCLUDING, BUT NOT LIMITED TO, THE IMPLIED WARRANTIES OF MERCHANTABILITY OR FITNESS FOR A PARTICULAR PURPOSE. Some states do not allow disclaimer of express or implied warranties in certain transactions; therefore, this statement may not apply to you.

This publication could include technical inaccuracies or typographical errors. Changes are periodically made to the information herein; these changes will be incorporated in later editions. Improvements or changes in the products or the programs described may be made at any time.

Comments may be addressed to Lexmark International, Inc., Department D22A/032-2, 740 West New Circle Road, Lexington, Kentucky 40550, U.S.A or electronically mailed (e-mail) to ServiceInfoAndTraining@Lexmark.com. Lexmark may use or distribute any of the information you supply in any way it believes appropriate without incurring any obligation to you. You can purchase additional copies of publications related to this product by calling 1-800-553-9727. In other countries, contact your point of purchase.

Lexmark and Lexmark with diamond design are trademarks of Lexmark International, Inc., registered in the United States and/or other countries.

ImageQuick, Optra Forms, and PrintCryption are trademarks of Lexmark International, Inc.

PCL® is a registered trademark of the Hewlett-Packard Company.

PostScript® is a registered trademark of Adobe Systems Incorporated.

Other trademarks are the property of their respective owners.

© 2003, 2004 Lexmark International, Inc.

All rights reserved.

UNITED STATES GOVERNMENT RIGHTS

This software and any accompanying documentation provided under this agreement are commercial computer software and documentation developed exclusively at private expense.

Contents

Safety information	xi
Preface	xvi
Definitions	1-xvi
General information	1-1
Overview	1-1
Resolution	1-1
Model differences	1-1
Technical specifications	1-2
Toner darkness	1-2
Color correction settings	1-2
Physical specifications and weight	1-3
Print speed and performance	1-4
Performance	1-5
Time to first print	1-5
Processor	1-5
Duty cycle	1-5
Printer memory	1-6
Resident fonts	1-7
Paper and media specifications	1-8
Input and output configurations	1-8
Media size supported	1-10
Input media types and weights	1-15
Output media types and weights	1-16
Input capacity by media and source	1-18
Output capacity by media and source	1-19
Media guidelines	1-20
Print area	1-21
Options and features	1-22
Connectivity	1-23
Standard	1-23
Optional internal local connections	1-23
Network connections	1-24
Data streams	1-25
Operating systems	1-25

Power and electrical specifications	1-26
Power requirements	1-26
Electrical specifications	1-26
Operating clearances	1-27
Environment	1-27
Printer temperature and humidity	1-27
Maintenance approach	1-29
Standard inspection and cleaning procedure	1-29
Return parts	1-30
Service recommendations	1-30
Tools	1-31
Serial number, configuration ID, and part number	1-32
Abbreviations	1-33
Diagnostic information	2-1
Adjustments and procedures following parts replacement. . .	2-1
Start	2-3
Initial check	2-3
Printer messages	2-4
Service error message tables	2-4
Attendance messages	2-34
Maintenance analysis procedures (MAPS)	2-54
Symptom table	2-63
Service checks	2-68
Drive 1 DC motor service check	2-68
Drive 2 stepper motor service check	2-68
Duplex unit service check	2-69
Expansion paper feed service check	2-69
Face down stacker full service check	2-70
High-capacity feeder (HCF) service check	2-70
Finisher service check	2-71
Marks on paper service check	2-72
Operator panel service check	2-73
Paper carrying service check	2-74
Paper exit, face up service check	2-82
Paper skew service check	2-83
Paper tray missing service check	2-83
Photodeveloper missing service check	2-84
Power supply service check	2-85
210 Staple jam service check	2-86
Transfer belt up/down service check	2-87

Image quality troubleshooting	2-88
Print quality problems	2-88
Options service check	2-98
Diagnostic aids	3-1
Power-On Self Test sequence	3-1
Using the operator panel	3-2
Operator panel buttons	3-3
Printing the menu settings	3-4
Operator menu disabled	3-4
Menu overview	3-4
Diagnostic Mode	3-6
Adjustment example	3-8
Print tests	3-10
Hardware tests	3-12
High-capacity feeder tests	3-18
Finisher tests	3-20
Device tests	3-23
Diagnostics - printer setup	3-26
Defaults	3-26
Viewing and resetting the drum counters	3-28
Diagnostics - error log	3-31
Theory of operation	3-33
Processes and configuration	3-33
Electrophotography process	3-33
Development unit	3-34
Transfer unit	3-34
Cleaning unit	3-35
Paper feeding / fusing	3-35
Drive system	3-36
Paper feeding	3-37
Cassette paper feeder	3-37
Multipurpose feeding	3-38
Registration unit	3-38
Separation unit	3-39
Fuser unit	3-40
Delivery	3-41
Belt unit	3-42
Belt up/down	3-43
Expansion paper feeder	3-43

Duplex unit	3-44
Paper weight	3-45
Clearing paper jams	3-46
High-capacity feeder (HCF)	3-52
Maintenance Mode.	3-60
Finisher.	3-61
Finisher installation	3-73
Attaching the docking plate and guide rail	3-73
Combining the finisher and stand.	3-75
Attaching the bins.	3-79
Aligning the finisher and printer	3-80
Adjusting the wheels	3-88
Attaching the cables.	3-90
Hole punch adjustment.	3-94
Repair information	4-1
Service precautions	4-1
Handling printed circuit boards.	4-1
Adjustments	4-3
High-capacity paper feed timing belt adjustment	4-3
Removals	4-4
Cover, top removal.	4-4
Cover, front removal.	4-5
Cover, front left removal.	4-5
Cover, rear removal	4-6
Cover, solenoid removal.	4-6
Cover, left side removal	4-7
Cover, right side removal	4-8
Cover, RIP board removal	4-9
Tray, paper exit removal.	4-10
Belt up/down clutch removal	4-10
Belt up/down detection sensor removal	4-11
Cassette guide removal	4-12
Connector, duplex unit removal	4-13
Separation fingers removal	4-14
Sensor cleaner removal	4-14
Drive gear unit sensor assembly removal	4-15
Drive motor assembly removal.	4-16
Electronic box removal.	4-17
Fanning pad removal	4-19

Front cover open switch actuator removal	4-20
Fuser removal	4-21
High voltage power supply board (HVU) removal	4-23
LED printhead removal	4-24
Eraser removal	4-27
Lock handle assembly removal	4-28
Main drive unit removal	4-29
Main unit fan removal	4-32
Motor drive board removal	4-33
Multipurpose feeder paper present sensor removal	4-33
Multipurpose feeder tray removal	4-34
Operator panel removal	4-34
Paper carrying frame removal	4-35
Paper carrying roller removal	4-36
Paper feed frame removal	4-37
Paper feed roller removal	4-38
Paper present sensor removal	4-38
Paper remaining sensor removal	4-39
Paper size sensor board assembly removal	4-39
Power supply 1 removal	4-40
Power supply 2 removal	4-41
Power switch removal	4-42
Printer controller removal	4-43
Printhead controller board removal	4-44
Registration sensor removal	4-48
Right slide rail removal	4-49
RIP box removal	4-49
Sensor board removal	4-50
Stay arm removal	4-51
Sub-frame removal	4-52
Sub frame F1, sub frame F2 removal	4-53
Top unit removal	4-55
Transfer belt removal	4-56
Turn guide cover sensor removal	4-65
Upper fan removal	4-66
Options removals	4-67
Expansion paper feeder removal	4-67

Duplex removals	4-75
Duplex unit separation removal	4-75
Duplex unit removal	4-76
Duplex timing belt removal	4-76
Duplex pressure roller and solenoid removal	4-77
Duplex feed roller and solenoid removal	4-78
Duplex side fence motor assembly/side fence removal	4-79
Duplex paper carrying motor removal	4-80
High-capacity feeder (HCF) removals	4-81
HCF covers removal	4-81
HCF call roller, paper feed roller, reverse roller removal ...	4-82
HCF pickup solenoid removal	4-83
HCF tray motor removal	4-86
HCF paper level sensor removal	4-87
HCF power supply removal	4-88
Finisher removals	4-89
External covers removals	4-89
Finisher control board removal	4-90
Elevator motor removal	4-91
Feed motor assembly removal	4-91
Hole punch removal	4-92
Inverter paper exit discharge brush removal	4-93
Inverter paper exit roller removal	4-93
Jogging unit removal	4-95
Path select gate removal	4-96
Patting roller removal	4-97
Power supply removal	4-99
Registration roller removal	4-100
Registration roller clutch removal	4-101
Stack area discharge brush removal	4-102
Staple unit removal	4-102
Straight paper exit discharge brush removal	4-103
Straight paper exit roller removal	4-103
Timing belts 1 and 2 removal	4-105
Tractor belt removal	4-106
Tractor drive motor assembly removal	4-108

Locations	5-1
Covers diagram	5-1
Major parts diagram	5-2
Sensor and switch locations	5-4
Component locations	5-6
Printer controller board	5-8
Printer controller board connectors	5-9
Printhead controller board	5-12
RIP board	5-13
Power source unit 1 board	5-14
Power source unit 2 board	5-14
High voltage power supply board	5-15
Sensor board	5-15
Expansion paper feeder controller board	5-16
Duplex unit controller board	5-16
Motor drive board	5-16
Size sensor board	5-17
High-capacity feeder (HCF)	5-18
High-capacity paper feed configuration	5-18
Electrical parts layout	5-19
Driving parts layout	5-20
Finisher locations	5-21
Preventive maintenance	6-1
Maintenance kit	6-1
Periodic maintenance	6-2
Lubricants and cleaners	6-2
Parts catalog	7-1
How to use this parts catalog	7-1
Assembly 1: Covers 1	7-2
Assembly 2: Covers 2	7-4
Assembly 3: Covers 3	7-6
Assembly 4: Covers 4	7-8
Assembly 5: Covers 5	7-10
Assembly 6: Upper unit	7-12
Assembly 7: Base 1	7-16
Assembly 8: Base 2	7-18
Assembly 9: Base 3	7-20

Assembly 10: Electrical	7-22
Assembly 11: Rip board	7-26
Assembly 12: Fuser unit	7-28
Assembly 13: Cassette	7-30
Assembly 14: Expansion feeder 1	7-32
Assembly 15: Expansion feeder 2	7-34
Assembly 16: Duplex unit 1	7-38
Assembly 17: Duplex unit 2	7-40
Assembly 18: High-capacity feeder 1	7-42
Assembly 19: High-capacity feeder 2	7-44
Assembly 20: High-capacity feeder 3	7-46
Assembly 21: High-capacity feeder 4	7-48
Assembly 22: High-capacity feeder 5	7-50
Assembly 23: High-capacity feeder 6	7-52
Assembly 24: Finisher covers	7-54
Assembly 25: Finisher frame	7-56
Assembly 26: Finisher feed 1	7-58
Assembly 27: Finisher feed 2	7-62
Assembly 28: Finisher elevator	7-64
Assembly 29: Finisher electronics	7-66
Assembly 30: Finisher docking 1	7-68
Assembly 31: Finisher docking 2	7-70
Assembly 32: Miscellaneous/options	7-72
Assembly 33: Finisher parts packet P/N 56P9480	7-81
Index	I-1
Part number index	I-9

Safety information

- The safety of this product is based on testing and approvals of the original design and specific components. The manufacturer is not responsible for safety in the event of use of unauthorized replacement parts.
- The maintenance information for this product has been prepared for use by a professional service person and is not intended to be used by others.
- There may be an increased risk of electric shock and personal injury during disassembly and servicing of this product. Professional service personnel should understand this and take necessary precautions.
-  **CAUTION:** When you see this symbol, there is a danger from hazardous voltage in the area of the product where you are working. Unplug the product before you begin, or use caution if the product must receive power in order to perform the task.

Consignes de sécurité

- La sécurité de ce produit repose sur des tests et des agréments portant sur sa conception d'origine et sur des composants particuliers. Le fabricant n'assume aucune responsabilité concernant la sécurité en cas d'utilisation de pièces de rechange non agréées.
- Les consignes d'entretien et de réparation de ce produit s'adressent uniquement à un personnel de maintenance qualifié.
- Le démontage et l'entretien de ce produit pouvant présenter certains risques électriques, le personnel d'entretien qualifié devra prendre toutes les précautions nécessaires.
-  **ATTENTION :** Ce symbole indique la présence d'une tension dangereuse dans la partie du produit sur laquelle vous travaillez. Débranchez le produit avant de commencer ou faites preuve de vigilance si l'exécution de la tâche exige que le produit reste sous tension.

Norme di sicurezza

- La sicurezza del prodotto si basa sui test e sull'approvazione del progetto originale e dei componenti specifici. Il produttore non è responsabile per la sicurezza in caso di sostituzione non autorizzata delle parti.
- Le informazioni riguardanti la manutenzione di questo prodotto sono indirizzate soltanto al personale di assistenza autorizzato.
- Durante lo smontaggio e la manutenzione di questo prodotto, il rischio di subire scosse elettriche e danni alla persona è più elevato. Il personale di assistenza autorizzato deve, quindi, adottare le precauzioni necessarie.
-  **ATTENZIONE:** Questo simbolo indica la presenza di tensione pericolosa nell'area del prodotto. Scollegare il prodotto prima di iniziare o usare cautela se il prodotto deve essere alimentato per eseguire l'intervento.

Sicherheitshinweise

- Die Sicherheit dieses Produkts basiert auf Tests und Zulassungen des ursprünglichen Modells und bestimmter Bauteile. Bei Verwendung nicht genehmigter Ersatzteile wird vom Hersteller keine Verantwortung oder Haftung für die Sicherheit übernommen.
- Die Wartungsinformationen für dieses Produkt sind ausschließlich für die Verwendung durch einen Wartungsfachmann bestimmt.
- Während des Auseinandernehmens und der Wartung des Geräts besteht ein zusätzliches Risiko eines elektrischen Schlags und körperlicher Verletzung. Das zuständige Fachpersonal sollte entsprechende Vorsichtsmaßnahmen treffen.
-  **ACHTUNG:** Dieses Symbol weist auf eine gefährliche elektrische Spannung hin, die in diesem Bereich des Produkts auftreten kann. Ziehen Sie vor den Arbeiten am Gerät den Netzstecker des Geräts, bzw. arbeiten Sie mit großer Vorsicht, wenn das Produkt für die Ausführung der Arbeiten an den Strom angeschlossen sein muß.

Pautas de Seguridad

- La seguridad de este producto se basa en pruebas y aprobaciones del diseño original y componentes específicos. El fabricante no es responsable de la seguridad en caso de uso de piezas de repuesto no autorizadas.
- La información sobre el mantenimiento de este producto está dirigida exclusivamente al personal cualificado de mantenimiento.
- Existe mayor riesgo de descarga eléctrica y de daños personales durante el desmontaje y la reparación de la máquina. El personal cualificado debe ser consciente de este peligro y tomar las precauciones necesarias.
-  **PRECAUCIÓN:** este símbolo indica que el voltaje de la parte del equipo con la que está trabajando es peligroso. Antes de empezar, desenchufe el equipo o tenga cuidado si, para trabajar con él, debe conectarlo.

Informações de Segurança

- A segurança deste produto baseia-se em testes e aprovações do modelo original e de componentes específicos. O fabricante não é responsável pela segurança, no caso de uso de peças de substituição não autorizadas.
- As informações de segurança relativas a este produto destinam-se a profissionais destes serviços e não devem ser utilizadas por outras pessoas.
- Risco de choques eléctricos e ferimentos graves durante a desmontagem e manutenção deste produto. Os profissionais destes serviços devem estar avisados deste facto e tomar os cuidados necessários.
-  **CUIDADO:** Quando vir este símbolo, existe a possível presença de uma potencial tensão perigosa na zona do produto em que está a trabalhar. Antes de começar, desligue o produto da tomada eléctrica ou seja cuidadoso caso o produto tenha de estar ligado à corrente eléctrica para realizar a tarefa necessária.

Informació de Seguretat

- La seguretat d'aquest producte es basa en l'avaluació i aprovació del disseny original i els components específics. El fabricant no es fa responsable de les qüestions de seguretat si s'utilitzen peces de recanvi no autoritzades.
- La informació pel manteniment d'aquest producte està orientada exclusivament a professionals i no està destinada a ningú que no ho sigui.
- El risc de xoc elèctric i de danys personals pot augmentar durant el procés de desmuntatge i de servei d'aquest producte. El personal professional ha d'estar-ne assabentat i prendre les mesures convenients.
-  **PRECAUCIÓ:** aquest símbol indica que el voltatge de la part de l'equip amb la qual esteu treballant és perillós. Abans de començar, desendolleu l'equip o extremeu les precaucions si, per treballar amb l'equip, l'heu de connectar.

안전 사항

- 본 제품은 원래 설계 및 특정 구성품에 대한 테스트 결과로 안정성이 입증된 것입니다. 따라서 무허가 교체부품을 사용하는 경우에는 제조업체에서 안전에 대한 책임을 지지 않습니다.
- 본 제품에 관한 유지 보수 설명서는 전문 서비스 기술자 용으로 작성된 것이므로, 비전문가는 사용할 수 없습니다.
- 본 제품을 해체하거나 정비할 경우, 전기적인 충격을 받거나 상처를 입을 위험이 커집니다. 전문 서비스 기술자는 이 사실을 숙지하고, 필요한 예방 조치를 취하도록 하십시오.
-  **주의:** 이 표시는 해당영역에서 고압전류가 흐른다는 위험 표시입니다. 시작전에 플러그를 뽑으시거나, 주의를 기울여 주시기 바랍니다.

安全信息

本产品的安全性以原来设计和特定产品的测试结果和认证为基础。万一使用未经许可的替换部件，制造商不对安全性负责。

本产品的维护信息仅供专业服务人员使用，并不打算让其他人使用。

本产品在拆卸、维修时，遭受电击或人员受伤的危险性会增高，专业服务人员对这点必须有所了解，并采取必要的预防措施。



切记：当您看到此符号时，说明在您工作的产品区域有危险电压的存在。请在开始操作前拔掉产品的电源线，或者在产品必须使用电源来执行任务时，小心从事。

Preface

This manual contains maintenance procedures for service personnel. It is divided into the following chapters:

1. **General information** contains a general description of the printer and the maintenance approach used to repair it. Special tools and test equipment are listed, as well as general environmental and safety instructions.
2. **Diagnostic information** contains an error indicator table, symptom tables, and service checks used to isolate failing field replaceable units (FRUs).
3. **Diagnostic aids** contains tests and checks used to locate or repeat symptoms of printer problems.
4. **Repair information** provides instructions for making printer adjustments and removing and installing FRUs.
5. **Connector locations** uses illustrations to identify the connector locations and test points on the printer.
6. **Preventive maintenance** contains the lubrication specifications and recommendations to prevent problems.
7. **Parts catalog** contains illustrations and part numbers for individual FRUs.

Definitions

Note: A note provides additional information.

Warning: A warning identifies something that might damage the product hardware or software.

CAUTION: A caution identifies something that might cause a servicer harm.



CAUTION: When you see this symbol, there is a danger from hazardous voltage in the area of the product where you are working. Unplug the product before you begin, or use caution if the product must receive power in order to perform the task.

1. General information

Overview

The Lexmark™ C91x printers are high-speed, wide-format color LED Electrophotographic color printers with superior print quality for high-volume printing.

Resolution

- 600 x 600 dpi
- 2400 image quality

Model differences

	5055-230 C912	5055-210 C912	5055-200 C912	5055-01N C910	5055-010 C910
28/29 ppm engine	X	X	X	X	X
USB/parallel			X		X
USB/Ethernet	X	X		X	
Memory (MB)	256	256	128	64	64
Options available					
550-sheet drawer	X	X		X	
Duplex	X			X	
Hard disk	X			X	
Staple and punch finisher w/stand	X			X	
Printer cabinet	X			X	

Technical specifications

Toner darkness

Toner darkness settings offer four user-selectable settings to balance print darkness and toner savings. The higher the setting, the darker the print. The toner darkness default setting is 4.

The toner darkness setting is available through the operator panel under the Print Quality menu.

Color correction settings

There are four color correction settings to provide flexibility in choosing the type of color correction to be applied when printing a file.

- Auto (default)—provides ease of use with no color science knowledge required
- Vivid—adjusts CMYK components, with the result being colors that are more saturated
- Off—no color correction is implemented from RGB or CMYK applications
- CMYK—provides the application's color correction instead of the printer's algorithms

Black and White Lock—(in configuration menu) allows printer and network administrators to lock the printer in a mode that will only print black. This feature cannot be overridden with any other menu or driver selection.

Physical specifications and weight

Description	Height	Width	Depth	Weight
Printers				
Lexmark C91x ¹	20.2 in. (512 mm)	27.4 in. (695 mm)	25.8 in. (655 mm)	177 lb (80.5 kg)
Lexmark C91xn ^{2,4}	25.2 in. (641 mm)	27.4 in. (695 mm)	25.8 in. (655 mm)	217.8 lb (99.0 kg)
Lexmark C91xdn	25.2 in. (641 mm)	27.4 in. (695 mm)	25.8 in. (655 mm)	230.8 lb (104.9 kg)
Lexmark C91xrn ³	40.5 in. (1028 mm)	46.9 in. (1191 mm)	25.8 in. (655 mm)	336.4 lb (152.9 kg)
Fully configured ⁴	40.5 in. (1028 mm)	60.0 in. (1520 mm)	25.8 in. (655 mm)	443.3 lb (201.5 kg)
Options				
Duplex unit	4.7 in. (120 mm)	27.4 in. (695 mm)	13.8 in. (350 mm)	13.0 lb (5.9 kg)
550-Sheet drawer	5.1 in. (129 mm)	27.4 in. (695 mm)	25.8 in. (655 mm)	40.8 lb (18.5 kg)
High-capacity feeder, 3000-sheet	25.0 in. (635 mm)	14.2 in. (360 mm)	20.7 in. (525 mm)	50.0 lb (22.6 kg)
Staple Punch finisher, 1100-sheet (with stand)	41.7 in. (1060 mm)	19.5 in. (495 mm)	20.5 in. (520 mm)	56.9 lb (25.9 kg)
Furniture				
Printer cabinet	20.4 in. (517 mm)	26.6 in. (675 mm)	23.6 in. (598 mm)	57.5 lb (26.0 kg)
Printer base	10.2 in. (260 mm)	26.6 in. (675 mm)	23.6 in. (547 mm)	33.0 lb (15.0 kg)
<p>¹ Base model with standard 550-sheet input tray.</p> <p>² Network model is network-ready printer with standard 550-sheet input tray plus one optional 550-sheet drawer.</p> <p>³ Finisher model is a duplex model printer with 1100-sheet punch finisher and printer cabinet.</p> <p>⁴ Fully configured models include base printer with four standard 550-sheet input trays, 3000-sheet feeder, 1100-sheet staple punch finisher, duplex unit, and printer base.</p>				

Print speed and performance

	Standard and heavy media tray	High-capacity feeder	Multipurpose feeder
Simplex printing on letter-size media (pages per minute)¹			
Letter—8.5 in. x 11 in.	28	28	28
Ledger	16	N/A	16
Legal—8.5 in. x 14 in.	19	N/A	19
A3	16	N/A	16
A4—3.4 in. x 11.7 in.	29	29	29
A5/Executive	N/A	N/A	38
B4	18	N/A	18
B5	N/A	N/A	32
Transparencies	22	N/A	22
Card stock	N/A	N/A	11
Envelopes	N/A	N/A	11
Paper labels	22	N/A	22
Duplex printing on letter-size media (sides per minute)^{1,2,3,4}			
Letter—8.5 in. x 11 in.	19	19	19
Ledger	11	N/A	11
Legal—8.5 in. x 14 in.	12	N/A	12
A3	11	N/A	11
A4—3.4 in. x 11.7 in.	19	19	19
A5/Executive	N/A	N/A	20

B4	12	N/A	12
B5	N/A	N/A	19
<ol style="list-style-type: none"> ¹ Folio and statement paper support from multipurpose feeder only. ² Speeds. ³ When printing from the multipurpose feeder: Simplex—the first three pages print a “legal” speed with the balance printing at the speed consistent with the actual media size. Duplex—all pages print at “legal” speed. ⁴ Average duplex print performance measured under the following conditions: Simplex text document from the printer’s integrated tray to the printer’s standard output bin, with a job stream sufficiently long for the printer system to enter the maximum duplex print performance page sequence (2,4,6,1,3,5...) The first two sides (2 and 4) are not included in the performance computation since they “seed” the printer system’s paper path to achieve the maximum duplex print performance. 			

Performance

The Lexmark C91x printers support the speeds listed above.
Performance depends on:

- Interface to the host (USB, serial, parallel, network)
- Host system and application
- Page complexity and content
- Certain printer options installed or selected
- Printer memory
- Media size and type

Time to first print

Time to first print is 15 seconds.

Processor

- 400 MHz (C910)
- 600 MHz (C912)

Duty cycle

- Maximum duty cycle—100,000 pages
- True continuous duty cycle—10,000 pages
- Lifetime maximum duty cycle—600,000 pages

Printer memory

Memory configuration

DRAM memory	Standard	Maximum
Lexmark C910(n)	64MB	512MB
Lexmark C910dn	128MB	512MB
Lexmark C912(n)	128MB	512MB
Lexmark C912(dn)	256MB	512MB

Available memory options

Optional 64MB, 128MB and 256MB SDRAM DIMMs are available from Lexmark.

Flash memory options

Optional 4MB, 8MM and 16MB DIMMs are available from Lexmark.

Memory and expansion slots

- Memory slots for extra flash or DRAM
 - Two for Lexmark C910(n) and Lexmark C912(n)
 - One for Lexmark C910(dn) and Lexmark C912(dn)
- One expansion slot for optional interface cards
- One optional firmware expansion slots (application solution firmware card)
- One on-board hard disk interface (for optional hard disk)

SDRAM and flash memory options are interchangeable within any of the memory slots available on the system board. However, only one flash memory Maintenance Approach option will be recognized. If multiple flash memory options are installed, the system will recognize the largest one.

Resident fonts

Emulation	Scalable Fonts	Bitmapped fonts
PCL 6	84	2
PostScript 3	156	0

For a listing of specific fonts, visit www.lexmark.com.

There are 83 symbol sets in the PCL 6 emulation to support all the languages that use these characters.

Not all symbol sets are supported by all fonts. Refer to the *Technical Reference* or use the printer operator panel to find which symbol sets are supported by each font.

Support for the euro currency character is included in all applicable fonts for both PostScript and PCL emulations. Twelve PCL symbol sets support the euro character, including all seven Windows symbol sets.

Additional fonts can be downloaded to the printer RAM, optional Flash DIMM or hard disk. PCL emulation supports both scalable and bitmapped downloadable fonts. PostScript emulation supports only downloadable scalable fonts. Font cards and font cartridges are not supported.

Paper and media specifications

Capacity may vary and is subject to media specifications and printer operating environment. Capacities listed are based on plain paper at 75 g/m².

Input and output configurations

Sources and capacities	Lexmark C91x	Lexmark C91xn	Lexmark C91xdn
Input sources			
Number of standard sources	2	3	3
Optional input drawers	3	2	2
High-capacity feeder	1	1	1
Maximum number of input sources	6	6	6
Input capacities (sheets)			
Standard			
Primary tray	550	550	550
Second tray	N/A	550	550
Multipurpose tray	100	100	100
Total standard capacity	650	1,200	1,200
Optional			
500-sheet drawer	550	550	550
Heavy media tray ¹	Yes	Yes	Yes
High-capacity feeder ²	3,000	3,000	3,000
Maximum additional drawers	3	2	2

Sources and capacities	Lexmark C91x	Lexmark C91xn	Lexmark C91xdn
Maximum input capacity (without high-capacity feeder)	2,300	2,300	2,300
Maximum input capacity and high-capacity feeder	5,300	5,300	5,300
Output destination			
Number (standard)	1	1	1
Output capacities sheets			
Standard output bin	550	550	550
Face-up bin	100	100	100
Optional			
Finisher ^{3,4}	1,000	1,000	1,000
Maximum output capacity	1,650	1,650	1,650
Other			
Duplex unit	Yes	Yes	Standard
<p>¹ The heavy media tray is supported only as Tray 1 (top). ² A maximum of one high-capacity input drawer is supported on any model. ³ A maximum of one finisher is supported on any model. ⁴ The finisher requires installation of the 2 x 550-sheet drawer with the base or printer cabinet.</p>			

Media size supported

Input

	500-sheet input	multipurpose feeder	High-capacity feeder	Duplex	Heavy media tray
A4—8.27" x 11.7 in. (210 mm x 297 mm)	X	X	X	X	X
A5—5.83" x 8.27 in. (148 mm x 210 mm)		X		X	X
JIS-B5—7.17 in. x 10.23 in. (182 mm x 257 mm)		X		X	
JIS-B4—4.34 in. x 10.1 in. (364 mm x 252 mm)	X	X		X	X
Letter—8.5 in. x 11 in. (216 mm x 279 mm)	X	X	X	X	X
Legal—8.5 in. x 14 in. (216 mm x 256 mm)	X	X		X	X
Executive—7.25 in. x 10.5 in. (184 mm x 267 mm)		X		X	
Tabloid—11 in. x 17 in. (279.4 mm x 431.8 mm)	X	X		X	X
12 in. x 18 in. (305 mm x 457 mm) Lexmark C912 only	X	X		X	X
A3—11.69 in. x 16.54" in. (297 mm x 420 mm)	X	X		X	X

	500-sheet input	multipurpose feeder	High-capacity feeder	Duplex	Heavy media tray
Universal ^{1,2} Banner 11.69 x 36 in. (297.2 x 914.4 mm) Lexmark C912 only 2.75 x 5 in. to 8.5 x 14 in. (69.85 x 127 mm to 229 x 355.6 mm) 5.83 x 7.17 in. to 8.5 x 14 in. (148 x 182 mm to 215.9 x 355.6 mm)		X		X ³	X
7 ¾ Envelope—3.875 in. x 7.5 in. (98 mm x 191 mm)		X			
9 Envelope—3.875 in. x 8.9 in. (98 mm x 225.4 mm)		X			
10 Envelope—4.125 in. x 9.5 in. (105 mm x 241 mm)		X			
DL Envelope—4.33 in. x 8.66 in. (110 mm x 220 mm)		X			
C4 Envelope—9 in. x 12.75 in. (229 mm x 324 mm)		X			
C5 Envelope—6.38 in. x 9.01 in. (162 mm x 229 mm)		X			
B5 Envelope—6.93 in. x 9.84 in. (176 mm x 250 mm)		X			
Other Envelope ⁴ — 11.69 in. x 11.69 in. (297 mm to 297 mm)		X			

	500-sheet input	multipurpose feeder	High-capacity feeder	Duplex	Heavy media tray
Media type					
Paper	X	X	X	X	X
Card stock		X			
Transparencies		X ⁵			X
Envelopes		X			
Glossy paper	X	X ⁶		X	X
Paper labels		X ⁷			X ⁸

Output

	Standard output	Bin 1	Finisher Bin 1	Finisher Bin 2
A4—8.27 in. x 11.7 in. (210 mm x 297 mm)	X	X	X	X
A5—5.83 in. x 8.27 in. (148 mm x 210 mm)	X	X	X	
JIS-B5—7.17 in. x 10.23 in. (182 mm x 257mm)		X	X	
JIS-B4—14.34 in. x 10.1 in. (364 mm x 252 mm)	X	X	X	
Letter—8.5 in. x 11 in. (216 mm x 279 mm)	X	X	X	X

	Standard output	Bin 1	Finisher Bin 1	Finisher Bin 2
Legal—8.5 in. x 14 in. (216 mm x 256 mm)	X	X	X	
Executive—7.25 in. x 10.5 in. (184 mm x 267 mm)	X	X	X	
Tabloid—11 in. x 17 in. (279.4 mm x 431.8 mm)	X	X	X	
12 in. x 18 in. (305 mm x 457 mm) Lexmark C912 only	X	X	X	
A3—11.69 in. x 16.54 in. (297 mm x 420 mm)	X	X	X	
Universal ^{1,2} Banner 11.69 x 36 in. (297.2 x 914.4 mm) Lexmark C912 only 2.75 x 5 in. to 8.5 x 14 in. (69.85 x 127 mm to 229 x 355.6 mm) 5.83 x 7.17 in. to 8.5 x 14 in. (148 x 182 mm to 215.9 x 355.6 mm)	X			
7 ¾ Envelope—3.875 in. x 7.5 in. (98 mm x 191 mm)		X		
9 Envelope—3.875 in. x 8.9 in. (98 mm x 225.4 mm)		X		
10 Envelope—4.125 in. x 9.5 in. (105 mm x 241 mm)		X		
DL Envelope—4.33 in. x 8.66 in. (110 mm x 220 mm)		X		
C4 Envelope—9 in. x 12.75 in. (229 mm x 324 mm)		X	X	

	Standard output	Bin 1	Finisher Bin 1	Finisher Bin 2
C5 Envelope—6.38 in. x 9.01 in. (162 mm x 229 mm)		X	X	
B5 Envelope—6.93 in. x 9.84 in. (176 mm x 250 mm)		X	X	
Other Envelope ⁴ —11.69 in. x 11.69 in. (297 mm to 297 mm)		X	X	
Media type				
Paper	X	X	X	X
Card stock	X	X	X	
Transparencies		X	X	
Envelopes		X	X	
Glossy paper	X	X	X	X
Paper labels		X	X	
<p>¹ When Universal is selected, the page is formatted for 8.5 x 14 in. (215.9 x 355.6 mm) unless the size is specified in the software application.</p> <p>² Narrow media should be loaded with the length in the feed direction (portrait).</p> <p>³ A5 paper 5.83 x 8.27 in. (148 x 210 mm) is the smallest size the printer can duplex.</p> <p>⁴ When Other Envelope is selected, the page is formatted for 8.5 x 14 in. (215.9 x 355.6 mm) unless the size is specified in the software application.</p> <p>⁵ Maximum stack of 50 sheets; if more input is required, use Heavy Media Tray.</p> <p>⁶ Manual feed (one sheet at a time) only; if more input is required, use Heavy Media Tray.</p> <p>⁷ Maximum stack of 30 sheets; if more input is required, use Heavy Media Tray.</p> <p>⁸ Refer to <i>Cardstock & Label Guide</i> for media guidelines.</p>				

Input media types and weights

Media	Weight
Standard trays^{1, 2, 3}	
Paper—xerographic or business	16 to 28 lb bond (60 to 105 g/m ²)
Specialty papers—glossy laser	80 lb book (32 lb bond) (120 g/m ²)
Heavy media tray¹	
Paper—xerographic or business	28 to 47 lb bond (105 to 176 g/m ²)
Specialty papers—glossy laser ⁴	80 lb book (32 lb bond) (120 g/m ²)
Transparencies—laser printer type ⁵	47 lb bond (175 g/m ²)
Labels—upper limit paper	48 lb bond (180 g/m ²)
Multipurpose feeder¹	
Paper—xerographic or business	16 to 28 lb bond (60 to 105 g/m ²)
Specialty papers—glossy laser	80 lb book (32 lb bond)(120 g/m ²)
Card stock—upper limit Index Bristol	90 lb index (44 lb bond) (165 g/m ²)
Transparencies—laser printer type	47 lb bond (175 g/m ²)
Labels—upper limit paper	48 lb bond (180 g/m ²)
Envelopes—sulfite, wood-free, up to 100% cotton	20 to 28 lb bond ^{2,3} (75 to 105 g/m ²)
High-capacity feeder¹	
Paper—xerographic or business	16 to 28 lb bond (60 to 105 g/m ²)
<p>¹ The duplex option supports the same weights and types as the printer, except for transparencies, envelopes, labels, and paper less than 80 g/m² (21.3 lb bond) or greater than 105 g/m² (28 lb bond).</p> <p>² 100% cotton content maximum weight is 90 g/m² (24 lb bond)</p> <p>³ 105 g/m² (28 lb bond) envelopes are limited to 25% cotton content</p> <p>⁴ Part numbers 12A5950 (letter) and 12A5951 (A4)</p> <p>⁵ Part numbers 12A5940 (letter) and 12A5941 (A4)</p> <p>⁶ Refer to <i>Cardstock & Label Guide</i> for media guidelines.</p>	

Output media types and weights

Media	Weight
Standard output³	
Paper—xerographic or business	16 to 28 lb bond (60 to 105 g/m ²)
Specialty papers—glossy laser	80 lb book (32 lb bond) (120 g/m ²)
Card stock—upper limit Index Bristol	90 lb index (44 lb bond) (165 g/m ²)
Transparencies—laser printer type	47 lb bond (175 g/m ²)
Labels—upper limit paper	48 lb bond (180 g/m ²)
Bin 1^{3, 4}	
Paper—xerographic or business	16 to 28 lb bond (60 to 105 g/m ²)
Specialty papers—glossy laser ¹	80 lb book (32 lb bond) (120 g/m ²)
Card stock—upper limit Index Bristol	90 lb index (44 lb bond) (165 g/m ²)
Transparencies—laser printer type ²	47 lb bond (175 g/m ²)
Labels—upper limit paper	48 lb bond (180 g/m ²)
Envelopes—sulfite, wood-free, up to 100% cotton	20 to 28 lb bond ^{6,7,8} (75 to 105 g/m ²)
Finisher bin 1^{3,4}	
Paper—xerographic or business	16 to 28 lb bond (60 to 105 g/m ²)
Specialty papers—glossy laser ¹	80 lb book (32 lb bond) (120 g/m ²)
Card stock—upper limit Index Bristol	90 lb index (44 lb bond) (165 g/m ²)
Transparencies—laser printer type ²	47 lb bond (175 g/m ²)
Labels—upper limit paper	48 lb bond (180 g/m ²)

Media	Weight
Finisher bin 2^{3, 4, 5}	
Paper—xerographic or business	16 to 28 lb bond (60 to 105 g/m ²)
<p>¹ Part numbers 12A5950 (letter) and 12A5951 (A4).</p> <p>² Part numbers 12A5940 (letter) and 12A5941 (A4).</p> <p>³ The duplex option supports the same weights and types as the printer, except for transparencies, envelopes, labels and paper less than 80 g/m² (21.3 lb bond) or greater than 105 g/m² (28 lb bond).</p> <p>⁴ Bin 1 represents engine side output and Finisher Bin 1 (face-up).</p> <p>⁵ Finisher supports hole punch, job offset and stapling.</p> <p>⁶ Finisher only supports long-edge fed envelopes wider than 5.8 in. (148 mm)—feed direction dimension.</p> <p>⁷ 100% cotton content maximum weight is 90 g/m² (24 lb bond).</p> <p>⁸ 105 g/m² (28 lb bond) envelopes are limited to 25% cotton content.</p>	

Input capacity by media and source

Media	Stack height	Capacity
500-Sheet trays		
Plain paper (letter, A4, legal, tabloid, A3)	2.2 in. (56 mm)	550 sheets 20 lb (75 g/m ²)
Plain paper (letter, A4, legal, tabloid, A3)	1 in. (25 mm)	240 sheets 24 lb (90 g/m ²)
Glossy paper	0.6 in. (15 mm)	130 sheets 32 lb (120 g/m ²)
Multipurpose feeder		
Plain paper	0.4 in. (11 mm)	100 sheets 20 lb (75 g/m ²)
Transparencies		50 transparencies
Envelopes		10 envelopes
Card stock		55 sheets 90 lb index (163 g/m ²)
Paper labels		55 sheets up to 48 lb (180 g/m ²)
Glossy paper	(Manual)	1 sheet 32 lb (120 g/m ²)
High-capacity feeder		
Plain paper	12.5 in. (317 mm)	3,000 sheets 20 lb (75 g/m ²)
Heavy media tray		
Plain paper	1.6 in. (40 mm)	300 sheets 32 lb (120 g/m ²)
Transparencies	0.8 in. (20 mm)	150 transparencies 47 lb (175 g/m ²)
Paper labels	1.6 in. (40 mm)	200 sheets up to 48 lb (180 g/m ²)
Glossy paper	1.6 in. (40 mm)	360 sheets 32 lb (120 g/m ²)

Output capacity by media and source

Media	Stack heights	Capacity
Standard output bin		
Plain paper	Varies	550 sheets 20 lb (75 g/m ²)
Glossy paper	Varies	130 sheets 32 lb (120 g/m ²)
Bin 1 and Staple Punch Finisher Bin 1		
Plain paper	Varies	100 sheets 20 lb (75 g/m ²)
Transparencies	Varies	50 transparencies 47 lb (175 g/m ²)
Bin 2—Staple Punch Finisher		
Plain paper	6.0 in. (152 mm)	1,000 sheets 20 lb (75 g/m ²)
<p>Notes:</p> <ul style="list-style-type: none"> • Performance may vary subject to media specifications and printer operating environment • Media at ambient environment • All media is letter/A4, unless otherwise noted • All paper weights are stated in bond, unless otherwise noted 		

Media guidelines

Paper

Following are media guidelines for successful printing:

- Rough, highly textured, limp or pre-curved papers will result in lower print quality and more frequent paper feed failures.
- Colored papers, treated and preprinted papers, letterhead and labels must be able to withstand 338° F (170° C) fusing temperature.
- Preprinted forms and letterhead should be selected using guidelines found in the printer *User's Guide*. The chemical process used in preprinting may render some papers unsuitable.
- Unsuitable papers include multipart forms and documents; chemically treated papers; coated, synthetic, and thermal papers; and preprinted papers requiring a high degree of registration.
- Recycled paper less than 21 lb (80 g/m²) may cause unacceptable results.

Envelopes

- Envelopes should be fed long edge first, with flap trailing.
- When the finisher is attached, only long-edge fed envelopes wider than 5.8 in. (148 mm) feed direction dimension may be used. To print smaller envelopes, the finisher must be undocked during the job.
- If envelope wrinkling occurs, refer to the *User's Guide* for correct weight, type, loading and stacking of envelopes.
- All envelopes should be new, unused and without package damage.
- Envelopes with excessive curl or twist exceeding 0.12 in. (6 mm), stuck together, with bent corners or nicked edges or those that interlock should not be used.

- Minimum weight: 20 lb (75 g/m²)
- The following envelopes should not be used:
 - Envelopes with windows, holes, perforations, cutouts, deep embossing or package damage
 - Envelopes with metal clasps, string ties or metal folding bars
 - Envelopes with exposed flap adhesive when the flap is in the closed position

For best results, printing on new 24 lb (90 g/m²) sulfite or 25% cotton bond envelopes is recommended.

Note: Under high-humidity conditions (over 60%) the envelopes may seal during printing.

Transparencies

Use letter (p/n 12A5940) or A4 (p/n 12A5941) only

Labels

Labels should be selected using guidelines found in the *User's Guide* or the *Cardstock and Label Guide*, and tested for acceptability.

Lexmark glossy paper

- Use letter (p/n 12A5950) or A4 (p/n 12A5951) only
- Glossy paper is only supported from Tray 1, Multipurpose Feeder, and Heavy Media Tray.

Print area

Printable area for the printer is to within 0.16 in. (4.2 mm) of all edges of the media (except envelopes).

Options and features

Lexmark C91x printers support only Lexmark C91x paper-handling options. These options are not compatible with any other Lexmark printer.

- **550-Sheet drawer**—(includes 550-sheet tray and support unit) installs beneath the printer and holds approximately 550 sheets of 20 lb paper. Multiple optional drawers (up to 3) are supported simultaneously.
- **High-capacity feeder**—is designed to provide an additional input tray (Tray 3 or Tray 5, depending on the configuration) with a total capacity of 3,000 sheets (plain paper—letter or A4—20 lb (75 g/m²)). The high-capacity feeder is customer installable and attaches to the right side of the printer.
- **Heavy-media tray**—is intended for special media such as transparencies, labels and glossy paper. This is supported only as Tray 1 (top drawer location).
- **Duplex unit**—offers two-side printing and is designed to complement the Lexmark C91x printers.
- **Finisher**—offers stapling, hole punching, offset stacking and an additional output bin. Two models are available. 3- or 4-hole left-edge hole punching is available. The single staple position is the upper left corner. The finisher can support up to 1,100 sheets of unstapled, unpunched media. For stapled media, the output bin supports up to 30 stapled sets or 1,000 sheets. The stapler can staple a maximum of 30 sheets per set. Each printer can support a single finisher.
- **Printer cabinet**—is customer installable and attaches so the printer sits on top of the printer stand. The printer cabinet raises the printer to the correct height for use with the optional finisher and high-capacity feeder. The printer cabinet and high-capacity feeder can be installed at the same time.
 - C91x – 1 optional drawer
 - C91xn or dn – no optional drawers

- **Printer base**—is customer installable and attaches so the printer sits on top of the printer base. If used with two optional 550-sheet drawers, the printer base raises the printer to the correct height for use with the optional finisher and high-capacity feeder. The printer base and high-capacity feeder can be installed at the same time.
 - C91x –3 optional drawers
 - C91xn and C91xdn –2 optional drawers

Connectivity

Standard

- Lexmark C91x
 - Bidirectional parallel and USB
- Lexmark C91xn and Lexmark C91xdn
 - 10/100BaseTX Ethernet and USB

Note: USB is supported only under Windows 98 SE, Windows Me, Windows XP, Windows 2000 operating systems, Sun's Sun Ray appliances running Sun Ray Server code version 1.2 or later, Sun Blade workstations and Apple Macintosh iMac computer with Operating System 8.6 or higher. A USB cable is included with this card.

Optional internal local connections

- Tri-Port Adapter (RS-232/RS-422 Serial, LocalTalk and Infrared)
- RS-232C Serial/Parallel-C Interface Card

Network connections

Internal network connections

- Lexmark MarkNet N2000 Series Internal Print Servers
 - MarkNet N2000t for Token-Ring attachment
 - MarkNet N2001e for Ethernet 10BaseT/100BaseTX
 - MarkNet N2002e for Ethernet 10BaseT/10Base2
- Lexmark MarkNet N2003 Series Internal Fiber Print Servers, including:
 - MarkNet N2003fx SC
 - MarkNet N2003fx MTRJ

External network connections

- MarkNet X2000 Series External Print Servers
 - MarkNet X2011e (1-port) for Ethernet 10BaseT/100BaseTX
 - MarkNet X2012e (1-port) for Ethernet 10BaseT/100BaseTX, 10BaseT/10Base2
 - MarkNet X2031e (3-port) for Ethernet 10BaseT/100BaseTX
 - MarkNet X2030t (3-port) for Token-Ring attachment

Standard Ethernet and MarkNet compatibility

The standard Ethernet connection, MarkNet N2000 series and MarkNet N2003 series internal and MarkNet X2000 series external print servers support NetPnP 7.0 or later on Windows NT 4.0, Windows 2000 and Windows XP systems.

The Ethernet and Token-Ring print servers and the standard Ethernet connection support the following protocols:

- TCP/IP
- Novell (IPX/SPX including NetWare Directory Services)
- AppleTalk
- LexLink (DLC/LLC)

The TCP/IP standard set of application services is supported, including DHCP, WINS, SNMP (industry standard printer MIB), http, lpr/lpd, ftp, tftp, ping, finger, telnet, bootp and rarp. The following protocols are also supported:

- IPP: Internet Printing Protocol
- SLP: Service Location Protocol
- NTP: Network Timing Protocol

Printers with standard Ethernet, MarkNet N2000 series and MarkNet N2003 series internal print servers and MarkNet X2000 series external print servers support a resident Web page with Microsoft Internet Explorer 4.0 or later and Netscape Navigator 4.5 or later for Windows 95, Windows 98, Windows Me, Windows 2000, Windows XP or Windows NT. The remote operator panel is available using the standard Ethernet connection, MarkNet N2000, MarkNet N2003 or MarkNet X2000 Series external print servers installed in or used with a Lexmark C91x printer.

Data streams

- PostScript 3 Emulation
- Hewlett-Packard Company PCL 6 Emulation

Operating systems

These printers are compatible with applications running under the previously mentioned operating systems for either local or network connections.

Power and electrical specifications

Power requirements

Average nominal power requirements for the base printer configuration (110 volt). Power level are shown in watts.

Printing states (average power)	Non-network	Network	Duplex/network
Off	0 W	*	*
Average power while printing			
Continuous mono	400 W	400 W	410 W
Continuous color	290 W	290 W	300 W
Average power while printing			
Continuous mono	13 W	14 W	15 W
Continuous color	125 W	125 W	125 W
Average power while printing			
Continuous mono	11 A	11 A	11 A
Continuous color	6 A	6 A	6 A
* 0 W. Always active and drawing voltage.			

Electrical specifications

Low voltage models

- 110 to 127 V at 50 to 60 hertz (Hz) nominal
- 99 to 135 V, extreme

High voltage models

- 220 to 240 V at 50 to 60 hertz (Hz) nominal
- 198 to 254 V, extreme

Note: Using a 220 to 110 power converter with the 110 V printer is not recommended.

Operating clearances

Dimension		Measurement	Notes
Left side		13 in. (330 mm)	Clearance on the left side should be 9 in. (228.6) with the finisher attached.
Right side	C91x(n)	6 in. (152 mm)	Clearance on right side should be 30 in. (762 mm) with the high-capacity feeder attached. Clearance on the right side should be 13 in. (330 mm) with the duplex attached, but not the high-capacity feeder.
	C91xdn	13 in. (330 mm)	
Front		26 in. (660 mm)	
Rear		5 in. (127 mm)	
Top		9 in. (229 mm)	With the high-capacity feeder or finisher attached, the top clearance needs to be 43.8 in. (1,113 mm).

Environment

Printer temperature and humidity

Operating

- Temperature: 60 to 90° F (15.6 to 32.3° C)
- Relative humidity: 8 to 80%
- Maximum wet bulb temperature: 73° F (22.8° C)
- Altitude: 10,000 ft. (0 to 3,048 meters)
- Atmospheric pressure: 74.6 kPa

Power Off

- Temperature: 50 to 110° F (10 to 43.3° C)
- Relative humidity: 8 to 80%
- Maximum wet bulb temperature: 80.1° F (26.7° C)
- Altitude: 10,000 ft. (0 to 3,048 meters)

Shipping printer without print cartridges

- Temperature: 0 to 140° F (0.6 to 60° C)
- Relative humidity: 5 to 100%
- Maximum wet bulb temperature: 85° F (30° C)
- Altitude: 34,000 ft. (10,300 meters)

Storing printer without print cartridges

- Temperature: 0 to 140° F (0.6 to 60° C)
- Relative humidity: 5 to 80%
- Maximum wet bulb temperature: 85° F (30° C)
- Altitude: 34,000 ft. (10,300 meters)

Shipping supply items

- Temperature: -40 to 104° F (-40 to 40° C)
- Relative humidity: 5 to 100%
- Maximum wet bulb temperature: 80° F (27° C)

Storing supply items

- Temperature: 0 to 104° F (0.6 to 40° C)
- Relative humidity: 5 to 80%
- Maximum wet bulb temperature: 80° F (27° C)

In some cases, performance specifications (such as paper OCF or EP cartridge usage) are specified to be measured at an ambient condition.

Maintenance approach

The diagnostic information in this manual leads you to the correct field replaceable unit (FRU) or part. Use the error code charts, symptom index, and service checks to determine the symptom and repair the failure. The removals in the repair information chapter may help you identify parts.

- **“Printer messages” on page 2-4**
- **“Symptom table” on page 2-63**
- **“Service checks” on page 2-68**
- **“Repair information” on page 4-1**

After you complete the repair, perform tests as needed to verify the repair. See **“Diagnostic aids” on page 3-1**.

Standard inspection and cleaning procedure

- Switch off printer power, and disconnect the AC power cord from the electrical outlet.
- Remove and inspect the photodevelopers and toner cartridges, shielding them from strong light.
- Inspect the interior of the printer, removing foreign matter such as paper clips, staples, pieces of paper or transparencies, paper dust, hair, oil, grease, or toner.
- Clean the printer interior using a lint-free cloth, dampened slightly with cold water. Do not use solvents or chemical cleaners to clean the printer interior.
- Use only the specified oil or lubricant on printer parts (some service parts are lubricated at the factory).
- Inspect and, if necessary, clean all rubber/plastic and D rolls with a lint-free cloth, dampened slightly with cold water. Dry the rolls with a lint-free cloth.
- While cleaning, inspect the interior of the printer for damaged wires, loose connections, toner leakage, loose springs, and damaged or worn parts.
- Be sure the printer is on a single, flat, strong table or desk top.

- Inspect all supplies (OCR, cartridges, photodevelopers/toner cartridges, belts, fuser CRUs) and paper sources (cassettes, trays, feeders, duplex drawers, finishers, mailbox trays) for obvious damage and proper installation (paper under corner bucklers, paper guides not too tight). Inspect for correct media usage (paper, transparencies, labels).
- Print a Demo page.
- If additional paper sources are installed, print a Demo page from each of these, (if possible).

Note: Failure to print from an additional tray or feeder may imply one or more pins are bent in the mating connector.

Return parts

Engineering periodically analyzes returned parts for failure modes. Include a printed test (DEMO) page, before and after the repair, and tag any returnable parts with a description of the failure.

Service recommendations

Before leaving the printer check the following:

- Be sure printer is on a flat, level, strong tabletop or level floor. This is very important for color printers that use belts. Check and set registration as necessary.
- Shake all cartridges and be sure they are correctly installed and fully seated.
- While the cover is open, wipe any residual toner from the LEDs using a lint free cloth.
- If you have serviced the finisher option, and in the process pulled it away from the printer during repair, ensure that it is properly aligned with the printer.

Tools

The removal and adjustment procedures require the following tools and equipment:

- Magnetic tip Phillips screwdrivers, large and small
- Flat-blade screwdrivers
- Analog volt ohmmeter (a digital volt ohmmeter may also be used)
- Needle nose pliers
- Tweezers, C-ring pliers
- Magnifier (20 times or higher)
- 6-angle wrench (1.5 mm)

When you make voltage readings, always use frame ground unless another ground is specified.

Serial number, configuration ID, and part number

Open the front door. The serial number, configuration ID, and part number are located as shown. The serial number is also on the menu settings page you can print from the Tests Menu.

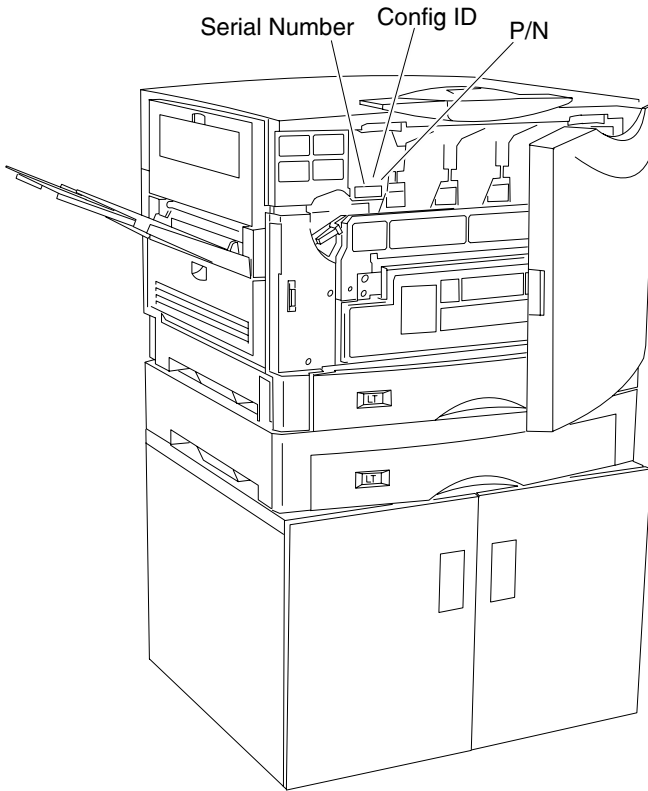

Abbreviations

ASIC	Application-specific integrated circuit
CSU	Customer setup
DRAM	Dynamic random access memory
EP	Electrophotographic process
EPROM	Erasable programmable read-only memory
ESD	Electrostatic discharge
FRU	Field replaceable unit
HVPS	High voltage power supply
LAN	Local area network
LASER	Light amplification by stimulated emission of radiation
LCD	Liquid crystal display
LED	Light-emitting diode
LVPS	Low voltage power supply
NVRAM	Nonvolatile random access memory
OEM	Original equipment manufacturer
PICS	Problem isolation charts
PIXEL	Picture element
POR	Power-on reset
POST	Power-on self test
PQET	Print quality enhancement technology
RIP	Raster image processor
ROS	Read-only storage
SRAM	Static random access memory
UPR	Used parts replacement
V ac	Volts alternating current
V dc	Volts direct current

5055-xxx

2. Diagnostic information

The diagnostic information in this chapter leads you to the failing part. Before you replace an entire assembly, determine if just the defective part is available in the parts catalog. Use the error code tables, symptom table, service checks and the diagnostic aids chapter to determine the symptom and repair the failure. The removal procedures in the Repair information chapter may help you identify parts. After you complete the repair, perform the appropriate tests to verify the repair.

If an error is displayed, locate it in the **“Service error message tables” on page 2-4**, the **“Attendance messages” on page 2-34**, or the **“Symptom table” on page 2-63** and take the appropriate action.

If an error message appears while you are working on the printer, go to the error message table and take the indicated action.

Adjustments and procedures following parts replacement

Note: When troubleshooting, or prior to making any adjustment to print quality, always be sure:

- The printer is installed on a level rigid surface.
- The photodevelopers are never exchanged. Do not exchange a black photodeveloper for a color photodeveloper, as they have different surface phase counts.
- The Alignment Page is used when adjusting print registration.

Whenever you replace any of the following parts be sure to perform the required adjustments or procedures. The adjustments are in the Repair information and Diagnostic aids chapters.

Printer controller board/printer control EPROM (U5)

If you replace the printer controller board, remove EPROM (U5) and install it on the new board. Also check the printhead alignment.

If you change the EPROM, record and input the following items using the diagnostic mode following EPROM replacement:

- LED Printhead Light Quantity
- Printer Alignment (X, Y, and Theta)
- All Counters

RIP controller board

If you replace the RIP controller board, move the solid state drive, memory, and option cards from the old card to the new one. After replacing the RIP controller board, it is necessary to type in the following items in Diagnostic Mode:

- Set Serial Number
- Configuration ID

Transfer belt

If you replace the transfer belt, check the printer alignment (X, Y, and *Theta*), adjusted in diagnostic mode.

LED printhead controller board or LED printhead

If you replace the LED printhead controller board or LED printhead, check and adjust the following items in diagnostic mode:

- LED Printhead Light Quantity
- Printer Alignment (X, Y, and Theta)

Start

Initial check

Before you start troubleshooting, check the following:

Installation environment

- The power supply line voltage is plus or minus 10% of the rated line voltage.
- The machine is securely installed on a level surface in a well-ventilated place.
- The room temperature is between 10 and 32°C (50 and 90°F) and the relative humidity between 20 and 80%.
- Avoid sites generating ammonia gas, high temperature, high humidity (near water faucets, kettles, humidifiers), cold spaces, near open flames, and dusty areas.
- Avoid sites exposed to direct sunlight.

Print paper checks

- Use the recommended paper for this printer.
- Paper dampness. Make a trial print with paper from a newly opened package, and check the result.

Printer messages

The printer displays three types of messages: service messages, status messages, and attendance messages. *Service messages* indicate a problem that requires a service technician. *Status messages* provide information about the current state of the printer, requiring no action. *Attendance messages* alert the operator to printer problems that require operator intervention.

Service error message tables

900 - Unrecoverable Software Error

910 Service Motor Error

910 - Drive Motor Error

Step	Questions/actions	Yes	No
1	Are connectors CN1 and CN5 on the motor drive board connected properly?	Go to step 2.	Connect CN1 and CN5.
2	Is connector CN33 on the printer controller board connected properly?	Replace the motor drive board and go to step 3.	Connect CN33.
3	Did replacement of the motor drive board solve the problem?	Problem solved.	Replace the printer controller board and go to step 4.
4	Did replacement of the printer controller board solve the problem?	Problem solved.	Replace all the supplies and go to step 5.
5	Did replacement of the supplies solve the problem?	Problem solved.	Replace the drive motor.

911 - Paper Exit Motor Error

Step	Questions/actions	Yes	No
1	Is connector CN4 on the printer controller board securely connected?	Replace the paper exit motor and go to step 2.	Plug the connector in securely.
2	Did replacement of the paper exit motor solve the problem?	Problem solved.	Replace the printer controller board.

912 - High-Capacity Feed Motor Error

Step	Questions/actions	Yes	No
1	Is connector CN40 on the printer controller board securely connected?	Go to “High-capacity feeder (HCF) service check” on page 2-70.	Plug the connector in securely.

917 - RIP Fan Error

917 Service Fan Error

Step	Questions/actions	Yes	No
1	Is connector J5 on the RIP board connected properly?	Go to step 2.	Properly connect J5.
2	Is 24 V dc present between pins 1 and 3 of connector J5 on the RIP board?	Replace the RIP fan.	Go to step 3.
3	Is 24 V dc present between pin 80 of the RIP/printer controller and ground?	Replace the RIP board.	Replace the printer controller board.

918 - Main Unit Fan Error

Step	Questions/actions	Yes	No
1	Is +24 V present between pins 1 and 3 on connectors CN17 (upper left fan) and CN5 (upper right fan) on the printer controller board?	Replace the failing fan.	Replace the printer controller board.

919 - Power Supply Fan Error

Step	Questions/actions	Yes	No
1	Is +24 V present between pins 1 and 3 of connector CN6 on the printer controller board?	Replace the power supply fan.	Replace the printer controller board.

92x Service Fuser Error

920 - Fuser Error—Fuser Heater Trouble

Step	Questions/actions	Yes	No
1	Replace the fuser. Did this fix the problem?	Problem solved.	Return the fuser, replace the power supply 2 and go to step 2.
2	Did replacing power supply 2 fix the problem?	Problem solved.	Return power supply 2 and replace the printer controller board.

923 - Upper Fuser Thermistor Open Error

Step	Questions/actions	Yes	No
1	Is connector CN44 on the printer controller board connected properly?	Disconnect CN44 and turn the printer on. Go to step 2.	Plug the connector in securely.
2	Is error 923 displayed?	Power off and reconnect CN44. Go to step 3.	Replace the printer controller board.
3	Power the printer off and short pins 1 and 4 of CN44 and power on. Is error 923 displayed?	Replace the fuser.	Replace the printer controller board.

924 - Lower Fuser Thermistor Open Error

Step	Questions/actions	Yes	No
1	Turn off the printer and reinstall the fuser, making sure it <i>clicks</i> into place. Turn on the printer. Did this resolve the problem?	Problem solved	Go to step 2
2	Is connector CN44 on the printer controller board connected properly?	Disconnect CN44 and turn the printer on. Go to step 3.	Plug the connector in securely.
3	Is error 924 displayed?	Turn the printer off and reconnect CN44. Go to step 4.	Replace the printer controller board.
4	Turn off the printer and short pins 8 and 11 of CN44. Turn on the printer. Is error 924 displayed?	Replace the fuser.	Replace the printer controller board.

925 - HVU Error

Step	Questions/actions	Yes	No
1	Has the high voltage power board (HVU) been removed/replaced?	Inspect the secondary card on the high voltage board (HVU) for a broken component (Q906). Replace the high voltage board (HVU) if necessary.	Go to step 2
2	Is connector CN42 on the printer controller board connected properly?	Replace the printer controller board. Go to step 3.	Plug the connector in securely.
3	Did replacing the printer controller board fix the problem?	Problem solved.	Replace the high voltage power board (HVU).

926(K), 927(C), 928(Y), 929(M) - Toner Sensor Error

92x Service Toner Sensor

Step	Questions/actions	Yes	No
1	Is the toner cartridge the correct type for the printer?	Go to step 2.	Recommend the customer replace the cartridge with the correct type.
2	Is the toner cartridge encoder wheel dirty?	Clean the encoder wheel and toner sensor.	Go to step 3.
3	Replace the toner cartridge for the color with the error. Did this fix the problem?	Problem solved.	Go to step 4.
4	Test the sensors. While actuating the sensor, does the voltage fluctuate between 0 V and +5 V between pins 1 and 2 on connectors CN22(K), CN21(Y), CN18(M), and CN19(C) on the printer controller board?	Replace the printer controller board.	Replace the affected toner sensor.

930 - Yellow Printhead Error

930 Service Printhead Error

Step	Questions/actions	Yes	No
1	<p>Check to ensure that the cables between the LED printhead and the printhead controller board as well as the cables between the printhead controller board and the printer controller board are properly connected.</p> <p>Are they properly connected?</p>	<p>If you have a printer with serial number XX-0XXXX, go to step 2.</p> <p>If you have a printer with serial number XX-1XXXX and above, go to step 4.</p>	Properly connect the cables.
2	<p>For serial number XX-0XXXX: Is fuse 5 on the printhead control board open?</p>	Replace the printhead control board, cables (CL13, CL24), and LED printhead.	Replace the printhead controller board and go to step 3.
3	<p>Did replacement of the printhead controller board correct the problem?</p>	Problem solved.	Replace the printer controller board.
4	<p>For serial number XX-1XXXX and above: Replace the LED printhead for the affected color.</p> <p>Did this resolve the problem?</p>	Problem solved.	Replace the printhead controller board and go to step 5.
5	<p>Did replacement of the printhead controller board resolve the problem?</p>	Problem solved.	Replace the printer controller board.

931 - Magenta Printhead Error

Step	Questions/actions	Yes	No
1	Check to ensure that the cables between the LED printhead and the printhead controller board as well as the cables between the printhead controller board and the printer controller board are properly connected. Are they properly connected?	If you have a printer with serial number XX-0XXXX, go to step 2. If you have a printer with serial number XX-1XXXX and above, go to step 4.	Properly connect the cables.
2	For serial number XX-0XXXX: Is fuse 6 on the printhead control board open?	Replace the printhead control board, cables (CL13, CL24), and LED printhead.	Replace the printhead controller board and go to step 3.
3	Did replacement of the printhead controller board correct the problem?	Problem solved.	Replace the printer controller board.
4	For serial number XX-1XXXX and above: Replace the LED printhead for the affected color. Did this resolve the problem?	Problem solved.	Replace the printhead controller board and go to step 5.
5	Did replacement of the printhead controller board resolve the problem?	Problem solved.	Replace the printer controller board.

932 - Cyan Printhead Error

Step	Questions/actions	Yes	No
1	<p>Check to ensure that the cables between the LED printhead and the printhead controller board as well as the cables between the printhead controller board and the printer controller board are properly connected.</p> <p>Are they properly connected?</p>	<p>If you have a printer with serial number XX-0XXXX, go to step 2.</p> <p>If you have a printer with serial number XX-1XXXX and above, go to step 4.</p>	Properly connect the cables.
2	<p>For serial number XX-0XXXX: Is fuse 3 on the printhead control board open?</p>	Replace the printhead control board, cables (CL13, CL24), and LED printhead.	Replace the printhead controller board and go to step 3.
3	Did replacement of the printhead controller board correct the problem?	Problem solved.	Replace the printer controller board.
4	<p>For serial number XX-1XXXX and above: Replace the LED printhead for the affected color.</p> <p>Did this resolve the problem?</p>	Problem solved.	Replace the printhead controller board and go to step 5.
5	Did replacement of the printhead controller board resolve the problem?	Problem solved.	Replace the printer controller board.

933 - Black Printhead Error

Step	Questions/actions	Yes	No
1	<p>Check to ensure that the cables between the LED printhead and the printhead controller board as well as the cables between the printhead controller board and the printer controller board are properly connected.</p> <p>Are they properly connected?</p>	<p>If you have a printer with serial number XX-0XXXX, go to step 2.</p> <p>If you have a printer with serial number XX-1XXXX and above, go to step 4.</p>	Properly connect the cables.
2	<p>For serial number XX-0XXXX: Is fuse 4 on the printhead control board open?</p>	Replace the printhead control board, cables (K13, K24), and LED printhead.	Replace the printhead controller board.
3	Did replacement of the printhead controller board correct the problem?	Problem solved.	Replace the printer controller board.
4	<p>For serial number XX-1XXXX and above: Replace the LED printhead for the affected color.</p> <p>Did this resolve the problem?</p>	Problem solved.	Replace the printhead controller board and go to step 5.
5	Did replacement of the printhead controller board resolve the problem?	Problem solved.	Replace the printer controller board.

934 - Color Drum Sensor Error

934 Service Drum Sensor

Step	Questions/actions	Yes	No
1	Is connector CN28 connected properly?	Go to step 2.	Plug the connector in securely.
2	Clean the color drum sensor LED. Did this fix the problem?	Problem solved.	Replace the color drum sensor. Go to step 3.
3	Did replacing the color drum sensor fix the problem?	Problem solved.	Replace the printer controller board.

935 - Black Drum Sensor Error

Step	Questions/actions	Yes	No
1	Is connector CN27 connected properly?	Go to step 2.	Plug the connector in securely.
2	Clean the black drum sensor LED. Did this fix the problem?	Problem solved.	Replace the black drum sensor. Go to step 3.
3	Did replacing the black drum sensor fix the problem?	Problem solved.	Replace the printer controller board.

936 - 939 Cassette Error

936 Service
Paper Option

Step	Questions/actions	Yes	No
1	Are connectors CN35 and CN36 on the printer controller board connected properly?	Replace the printer controller board.	Plug the connector in securely.

940 - High-Capacity Feed Sensor Error

Step	Questions/actions	Yes	No
1	Is connector CN40 on the printer controller board connected properly?	Go to “High-capacity feeder (HCF) service check” on page 2-70.	Plug the connector in securely.

941 - High-Capacity Feed Tray Error

Step	Questions/actions	Yes	No
1	Is connector CN40 on the printer controller board connected properly?	Go to “High-capacity feeder (HCF) service check” on page 2-70.	Plug the connector in securely.

942 - Duplex Error

942 Service
Duplex

Step	Questions/actions	Yes	No
1	Is connector CN37 on the printer controller board connected properly?	Replace the printer controller board.	Plug the connector in securely.

945 - Engine Flash Error

945 Service
Engine Flash

Reflash the engine code.

946 - Printer/Printhead Controller Board Communication Error

946 Service
Communication

Step	Questions/actions	Yes	No
1	Make sure all printhead LED EPROMS are present on the printhead controller board. Are all the EPROMS present?	Go to step 2	Install the EPROM(s) included with printhead FRU.
2	Replace the printhead controller board. Did this fix the problem?	Problem solved.	Replace the printer controller board.

947 - Finisher Communication Error

Step	Questions/actions	Yes	No
1	Are the finisher to printer interface cable and power cable properly connected?	Go to step 2.	Properly connect the cable.
2	Replace the interface cable. Did this resolve the problem?	Problem solved.	Replace the control finisher board. Go to step 3.
3	Did finisher control board replacement resolve the problem?	Problem solved.	Replace the printer control board.

948 - Machine ID Error

948 Service Machine ID

Step	Questions/actions	Yes	No
1	Turn the printer off and wait 30 seconds. Turn the printer on. Did this fix the problem?	Problem solved.	Verify proper installation of the EPROMs on both the printer controller board and the printhead controller board. Go to step 2.
2	Are the EPROMs installed correctly?	Replace the printer controller board. Go to step 3.	Install the EPROMs correctly.
3	Did replacing the printer controller board fix the problem?	Problem solved.	Replace the printhead controller board.

949 - Tray (x) Comm

Step	Questions/actions	Yes	No
1	Replace the printer controller board. Does this fix the problem?	Problem solved.	Replace the expansion feeder control board for trays 2-5. If the problem is with the high-capacity paper feeder, replace the HCPF board.

950 - Pr Control Board

Replace the printer controller board.

952 - NVRAM Chip Failure

952 Service
NVRAM Failure

Step	Questions/actions	Yes	No
1	Make sure the 80-pin RIP printer controller cable is not broken or damaged. Is the cable broken or damaged?	Replace the cable.	Go to step 2.
2	Is EPROM U5 present on the printer controller board?	Replace the printer controller board.	Install EPROM U5

954 - NVRAM CRC Failure

Replace the RIP board.

955 - Code CRC

955 Service Code CRC <loc>

Replace the RIP board.

956 - Processor Failure

956 Service System Board

Replace the RIP board.

957 - ASIC Failure

Replace the RIP board.

958 - NAND Failure

958 Service NAND Failure

Replace the RIP board.

960 - RAM Slot 1 Bad

960 Service RAM Memory Error

Replace the RAM card or the RIP board.

961 - RAM Slot 2 Bad

Replace the RAM card or the RIP board.

962 - RAM Slot 3 Bad

Replace the RAM card or the RIP board.

964 - Emulation Error

964 Service Emulation Error

Replace the DLE board. If this does not fix the problem, replace the RIP board.

970 - Standard Network Error

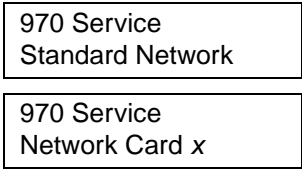

Check the network card in slot x on the RIP card.

975 - Unrecognizable Network Port

Software error.

976 - Unrecoverable Software Error in Network Port

Software error. Go to the **“Options service check” on page 2-98** and refer to the network card option section.

978 - Bad Checksum While Programming Network Card

Software error.

979 - Flash Parts Failed While Programming Network Port

Reflash network port.

980 - Face Up/Down Switching Error

980 Service
Switch Error

Check Area
B

Step	Questions/actions	Yes	No
1	Does the Face Up/Down (FU/FD) deflector move at all during power up?	Go to step 2.	Go to step 3.
2	Manually operate the FU/FD deflector. Does it properly lock into position when manually operated?	Go to step 3.	Go to step 4.
3	Is there continuity on the FU/FD deflector solenoid between pins 1 and 2 of CN14 on the printer controller board?	Go to step 5.	Replace the FU exit assembly.
4	Make sure that the FU/FD deflector pivot arm is in the proper position. Is it in the proper position with its operating linkage?	Replace the FU exit assembly.	Place the FU/FD pivot arm in the proper position.
5	Is fuse 1 on the printer controller board open?	Replace the printer controller board and drum eraser cable assembly.	Replace the printer controller board.

981 - Belt Up/Down Sensor Error

981 Service Switch Error

Step	Questions/actions	Yes	No
1	Is engine code level 41D or above.	Go to step 2.	Update the printer with code level 41D or above. If this does not resolve the problem, continue with step 2.
2	Are connectors CN409 and CN407 on the sensor board connected properly?	Go to step 3.	Plug the connectors in securely.
3	Are connectors CN26 and CN29 on the printer controller board connected properly?	Go to step 4.	Plug the connector in securely.
4	Remove the transfer belt. Verify the belt up/down sensor actuator flag is properly installed, not broken, and in the proper position. Make sure the sensor is fully snapped in place and that the sensor connector is fully seated. Are these items correct?	Go to step 5.	If the sensor is out of position or disconnected, properly install the sensor and securely connect the sensor connector. If the sensor actuator flag is broken, replace the belt up/down changing shaft.
5	Clean the belt up/down sensor. Does this fix the problem?	Problem solved.	Go to step 5.

Step	Questions/actions	Yes	No
6	Test the sensor. While actuating the sensor, does the voltage fluctuate between 0 V and +5 V between pins 7 and 8 of connector CN29 on the printer controller board?	Replace the belt up/down clutch. Go to step 7.	Replace the belt up/down sensor.
7	Did replacing the belt up/down clutch fix the problem?	Problem solved.	Replace the printer controller board.

982 - Sensor Controller Error

982 Service Sensor Control

Step	Questions/actions	Yes	No
1	Turn the printer off and wait 30 seconds. Turn the printer on. Is error 982 displayed?	Replace the printer controller board.	Problem solved.

983 - Black Gear Sensor Error

983 Service Gear Sensor

Step	Questions/actions	Yes	No
1	Is connector CN20 on the printer controller board connected properly?	Go to step 2.	Plug the connector in securely.
2	Check the cable running to CN20 for damage. Is the cable damaged?	Replace the cable.	Go to step 3.
3	Clean the gear sensor. Does this correct the problem?	Problem solved.	Go to step 4.
4	Replace the sensor card. Did this resolve the problem?	Problem solved.	Replace the drive unit.

984 - Yellow Gear Sensor Error

Step	Questions/actions	Yes	No
1	Is connector CN20 on the printer controller board connected properly?	Go to step 2.	Plug the connector in securely.
2	Check the cable running to CN20 for damage. Is the cable damaged?	Replace the cable.	Go to step 3.
3	Clean the gear sensor. Does this correct the problem?	Problem solved.	Go to step 4.
4	Replace the sensor card. Did this resolve the problem?	Problem solved.	Replace the drive unit.

985 - Transfer Belt Thermistor Error

985 Service Thermistor Error

Step	Questions/actions	Yes	No
1	Are connectors CN407 and CN408 on the sensor board connected properly?	Go to step 2.	Plug the connector in securely.
2	Is connector CN29 on the printer controller board connected properly?	Replace the transfer belt unit. If the problem remains, replace the printer controller board.	Plug the connector in securely.

986 - Transparency (OHP) Sensor Error

986 Service OHP Sensor

Step	Questions/actions	Yes	No
1	Are connectors CN15 (light emitting) and CN7 (light receiving) on the printer controller board connected properly?	Go to step 2.	Plug the connector in securely.
2	Test the sensor. While actuating the sensor, does the voltage fluctuate between 0 V and +5 between pins 2 and 3 of connector CN7 of the printer controller board?	Replace the printer controller board.	Replace the upper and lower transparency sensor.

992 - Temperature/Humidity Sensor Error

Step	Questions/actions	Yes	No
1	Is connector CN3 on the printer controller board connected properly?	Go to step 2.	Plug the connector in securely.
2	Replace the temperature and humidity sensor (a component of the paper feed solenoid assembly). Did this fix the problem?	Problem solved.	Replace the printer controller board.

993 CPU Error

Replace the printer controller board.

994 - Density Sensor Error

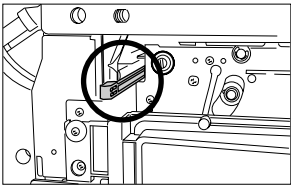
Step	Questions/actions	Yes	No
1	Is the front door fully closed?	Go to step 2.	Close the front door.
2	Is the density sensor actuator stuck in place? 	Release the density sensor actuator.	Go to step 3.
3	Are connectors CN406 and CN407 on the sensor board connected properly?	Go to step 4	Plug the connector in securely.
4	Is connector CN29 on the printer controller board connected properly?	Replace the density sensor. Go to step 5.	Plug the connector in securely.
5	Did replacing the density sensor fix the problem?	Problem solved.	Replace the printer controller board.

995 - Finisher Main Feed Motor abnormal

995 Service Finisher

Step	Questions/actions	Yes	No
1	Is there jammed paper or other obstructions in the paper path?	Clear the paper path.	Go to step 2.
2	Check to ensure the connector PJ6 on the finisher control board and the feed motor assembly cable are properly connected. Are the cables properly connected?	Go to step 3.	Properly connect the cables.
3	Make sure the finisher set switch is activated. Measure for +24 V dc ($\pm 10\%$) between pins 7 and 8 and +5 V dc ($\pm 10\%$) between pins 7 and 6 on the feed motor assembly cable connector CN1. Is either voltage missing?	Go to step 4.	Go to step 5.
4	Disconnect the feed motor assembly cable and PJ6 on the finisher control board. Measure continuity on the cable for all positions. Is there continuity?	Go to step 6.	Replace the cable.
5	Replace the feed motor assembly. Did this resolve the problem?	Problem solved.	Replace the finisher control board.

Step	Questions/actions	Yes	No
6	Measure for +24 V dc between pins 1 and 2 on connector PJ3 on the finisher control board. Measure for +5 V dc between pins 1 and 3 on PJ2 on the finisher control board. Is either voltage missing?	Replace the power supply.	Replace the finisher control board.

996 - Finisher Jogging Motor Error

Step	Questions/actions	Yes	No
1	Are there foreign objects or obstructions in the jogging assembly?	Clear the objects or obstruction.	Go to step 2.
2	Are the jogging motor connectors CN2 on the finisher control board securely connected?	Go to step 3.	Securely connect the connectors.
3	Make sure the finisher set switch is activated. Measure for +24 V dc ($\pm 10\%$) between pin 1 on CN2 and frame ground. Is +24 V dc present?	Go to step 4.	Go to step 5.
4	Replace the jogging motor assembly. Did this resolve the problem?	Problem solved.	Replace the finisher control board.
5	Disconnect CN2 and PJ5. Perform a continuity check on the cable for all positions. Is there continuity?	Go to step 6.	Replace the cable.
6	Check for +24 V dc ($\pm 10\%$) between pins 1 and 2 of PJ3 on the finisher control board. Is +24 V dc present?	Replace the finisher control board.	Replace the power supply.

997 - Finisher Tractor Motor Error

Step	Questions/actions	Yes	No
1	Are there obstructions or foreign objects in the accumulator or face down paper path?	Remove the objects or obstructions.	Go to step 2.
2	Are the connectors CN3 at the tractor motor and PJ4 on the finisher control board securely connected?	Go to step 3.	Securely connect the connectors.
3	Make sure the finisher set switch is activated. Measure +24 V dc between pin 1 of tractor motor connector CN3 and frame ground. Is +24 V dc ($\pm 10\%$)?	Go to step 4.	Go to step 5.
4	Replace the tractor motor assembly. Did this resolve the problem?	Problem solved.	Replace the finisher control board.
5	Disconnect CN3 and PJ4 on the finisher control board and perform a continuity check on all positions. Is there continuity on all positions?	Go to step 6.	Replace the cable.
6	Check for +24 V dc between pins 1 and 2 of PJ3 on the finisher control board. Is +24 V dc present?	Replace the finisher control board.	Replace the power supply.

998 - Tray Elevator Motor Error

Step	Questions/actions	Yes	No
1	Are the connectors CN4 at the tray elevator motor and connector PJ4 on the finisher control board properly connected?	Go to step 2.	Properly connect the connectors.
2	Make sure that the finisher set switch is activated. Power the printer off. Measure for approximately +24 V dc ($\pm 10\%$) between pins 1 and 2 of connector CN4 at the tray elevator motor. Power the printer on and observe the voltage meter during the first 12 seconds of power up. Is +24 V dc present while the printer is powering up?	Replace the tray elevator motor.	Go to step 3.
3	Disconnect CN4 at the tray elevator motor. Disconnect PJ4 on the finisher control board. Measure for continuity between CN4 pin 1 and PJ4 pin 7. Measure for continuity between CN4 pin 2 and PJ4 pin 8. Is there continuity in both locations?	Go to step 4.	Replace the cable.
4	Measure for +24 V dc ($\pm 10\%$) between pins 1 and 2 on connector PJ6. Is +24 V dc present?	Replace the finisher control board.	Replace the finisher power supply.

999 - Stapler Motor Error

Step	Questions/actions	Yes	No
1	Are staples jammed in the stapler?	Go to step 2.	Go to step 3.
2	Clear the staple jam and run the staple test in diagnostic mode or run a staple job. Does the problem reoccur?	Replace the staple cartridge and to go step 4.	Problem solved.
3	Are the connectors CN5 on the stapler and PJ1 on the finisher control board securely connected?	Go to step 5.	Securely connect the connectors.
4	Did replacement of the stapler cartridge resolve the problem?	Problem resolved.	Replace the stapler.
5	Make sure the finisher set switch is activated. Measure for 5 V dc between pins 11 and 12 on stapler connector CN5. Is 5 V dc present?	Replace the stapler.	Replace the finisher control board.
6	Did replacement of the finisher control board correct the problem?	Problem solved.	Go to step 7.
7	Is there continuity on the stapler to finisher control board cable?	Replace the power supply.	Replace the cable.

Attendance messages

Message	Meaning	Action
Activating Menu Changes	The printer is activating changes made to the printer settings.	Wait for the message to clear.
Bin <x> Full	The specified bin is full.	Remove the paper from the bin.
Busy	The printer is busy receiving, processing, or printing data.	Wait for the message to clear or press Menu to open the Job Menu and cancel the current job.
Canceling Fax	The printer is processing a request to cancel a fax job.	Wait for the message to clear.
Canceling Job	The printer is processing a request to cancel the current print job.	Wait for the message to clear.
Change <x>	The printer is requesting a different type of paper.	Change paper.
Check <device> connection	<ul style="list-style-type: none"> • The specified device is not fully connected. • Hardware failure. 	<ul style="list-style-type: none"> • Reestablish communication by reattaching the device. • Press Go to clear the message. • If a hardware failure, turn the printer off and back on. If the error recurs, turn the printer off, remove the specified device and call for service. If the error cannot be reset, go to “Map 10 - Unrecoverable Check Tray (x) or Duplex Connection message” on page 2-60.
Clearing Job Accounting Stat	The printer is deleting all job statistics stored on the hard disk.	Wait for the message to clear.

Message	Meaning	Action
Close Side Door	The printer side door is open.	Close the printer side door. If the error cannot be reset, go to “Map 1 - False Side Door Open message” on page 2-54.
Close Front Door	The printer front door is open.	Close the printer top door and front door. If the error cannot be reset go to “Map 2 - False Close Front Door message” on page 2-54.
Close Tray <x> Top Cover	The high-capacity feeder door is open.	Close the HCF door and the top cover. If the error cannot be reset, go to “Map 3 - False Close Tray (x) Top Cover message” on page 2-55.
Copying	The printer is processing a copy job originating from the scanner.	Wait for the message to clear.
Defragmenting	The printer is defragmenting the flash memory to reclaim storage space occupied by deleted resources.	Wait for the message to clear. Warning: Do not turn the printer off while this message is displayed.
Delete All Jobs	The printer is requesting confirmation to delete all held jobs.	<ul style="list-style-type: none"> • Press Go to continue. The printer deletes all held jobs. • Press Stop to cancel the operation.
Deleting Jobs	The printer is deleting one or more held jobs.	Wait for the message to clear.
Disabling Menus	The printer is responding to a request to disable the menus.	Wait for the message to clear. Note: While the menus are disabled, you cannot change the printer settings from the operator panel.

Message	Meaning	Action
Disk Corrupted Reformat?	The printer has attempted a disk recovery process and cannot repair the disk.	<ul style="list-style-type: none"> • Press Go to reformat the disk and delete all files currently stored on the disk. • Press Stop to clear the message without reformatting the disk.
Disk Recovery x/5 yyy%	The printer is attempting to recover the hard disk.	<p>Wait for the message to clear.</p> <p>Warning: Do not turn the printer off while this message is displayed.</p>
Enabling Menus	The printer is responding to a request to make the menus available to all users.	Wait for the message to clear and press Menu to view the menus available.
Engine Warming	The printer is warming the fuser assembly.	Wait for the message to clear.
Enter PIN: =_____	The printer is waiting for you to enter your four-digit PIN number.	Use the operator panel buttons to enter the PIN.
Fax <x>	The printer is processing an incoming fax.	Wait for the message to clear.
Flushing Buffer	The printer is flushing corrupted print data and discarding the current print job.	Wait for the message to clear.
Formatting Disk yyy%	The printer is formatting the hard disk. The second line shows percentage complete.	Wait for the message to clear.
Formatting Flash	The printer is formatting flash memory.	Wait for the message to clear.
Fuser Maintenance	The counter that tracks wear on the fuser has reached its limit.	<ul style="list-style-type: none"> • Press Go to continue printing. • If print quality is unacceptable, replace the fuser.

Message	Meaning	Action
Held Jobs May be Lost	The printer memory is too full.	<ul style="list-style-type: none"> • Press Go to clear the message. The printer frees memory by deleting the oldest job and continues deleting jobs until there is enough memory. • Press Stop to clear the message without deleting jobs. • Press Menu to open the Job Menu and cancel the current job.
Infrared <x>	An infrared interface is the active communication link.	Wait for the message to clear.
Insert Tray <x>	The specified tray is either missing or not fully inserted.	Insert the specified tray. If the error cannot be reset, go to “Paper tray missing service check” on page 2-83.
Install <device> or Cancel Job	The printer is requesting a specified device be installed so it can print.	<ul style="list-style-type: none"> • Turn the printer off, install the specified device and restart the printer. • Press Menu to open the Job Menu and cancel the current job.
Invalid Engine Code	The printer engine code has not been programmed or is not valid.	Call for service.
Invalid Network <x> Code	The code in an internal print server is not valid. The printer cannot receive and process jobs until valid code is programmed into the internal print server.	Download valid code to the printer internal print server.

Message	Meaning	Action
Load <x>	The printer is trying to feed paper from a source it detects is empty.	<p>Load paper of the size and type requested in the second line of the display in the specified tray. Press Menu to open the Job Menu and cancel the current job.</p> <ul style="list-style-type: none"> • If Load (Tray) cannot be reset, go to “Map 4 - False Tray (x) Low/ Empty message” on page 2-56. • If Load (MPF), check the MPF paper present sensor.
Load Manual	A request for a manual feed job has been sent to the printer. The printer is ready for insertion of a single sheet into the manual feed slot.	<ul style="list-style-type: none"> • Load a sheet of paper specified in the second line of the display in the manual feed tray or multipurpose feeder. • Press Select or Go to ignore the manual feed request and print on paper already in the printer. • Press Menu to open the Job Menu and cancel the current job.
LocalTalk <x>	A LocalTalk interface is the active communication link.	Wait for the message to clear.
Menus Disabled	The printer menus are disabled.	You can still open the Job Menu to cancel a job that is printing or to select a confidential job or a held job that you want to print.
Network Card Busy	An internal print server is being reset.	Wait for the message to clear.
Network <x>	A network interface is the active communication link.	Wait for the message to clear.

Message	Meaning	Action
Network <x>, <y>	Network interface is the active communication link, where <x> represents the active link and <y> represents the channel.	Wait for the message to clear.
No Jobs Found, Retry?	The PIN number entered is not associated with any confidential job.	<ul style="list-style-type: none"> • Press Go to enter another PIN. • Press Stop to clear the PIN entry prompt.
Not Ready	The printer is not ready to receive or process data.	Press Go to make the printer ready.
Parallel <x>	A parallel interface is the active communication link.	Wait for the message to clear.
Performing Self Test	The printer is running the series of start-up tests it performs after it is turned on.	Wait for the message to clear.
Power Saver	The printer is ready to receive data. It is reducing electricity consumption while idle.	<ul style="list-style-type: none"> • Send a job to the printer. • Press Go to quickly warm the printer to normal operating temperature and display the Ready message.
Print Jobs on Disk	Jobs spooled to the hard disk before the printer was last turned off have not yet printed.	<p>Press Go to print the jobs.</p> <p>Press Return or Stop to delete jobs.</p>
Printer Calibrating	The printer is adjusting the color tables to correct variations caused by environmental conditions.	Wait for the message to clear.
Printing Alignment Page	The printer is processing or printing a test page that shows alignment values.	Wait for the message to clear.
Printing Directory List	The printer is processing or printing a directory of all files stored in flash memory or on a hard disk.	Wait for the message to clear.

Message	Meaning	Action
Printing Font List	The printer is processing or printing a list of all available fonts for the specified printer language.	Wait for the message to clear.
Printing Job Accounting Stat	The printer is processing or printing all job accounting statistics stored on the hard disk.	Wait for the message to clear.
Printing Menu Settings	The printer is processing or printing the menu settings page.	Wait for the message to clear.
Prog Engine Code	The printer is programming new code into flash memory.	Wait for the message to clear.
Prog System Code	The printer is programming new system code.	Wait for the message to clear.
Program Flash	The printer is storing resources, such as fonts or macros, in flash memory.	Wait for the message to clear.
Programming Disk	The printer is storing resources, such as fonts or macros, on hard disk.	Wait for the message to clear.
Programming Error <x>	An error occurred while the printer was programming code into memory.	Correct the problem specified on the second line of the display.
Queuing and Deleting Jobs	The printer is deleting one or more held jobs and sending one or more jobs to print.	Wait for the message to clear.
Queuing Jobs	The printer is sending one or more held jobs to print.	Wait for the message to clear.
Ready	The printer is ready to receive and process print jobs.	Send a job to print.

Message	Meaning	Action
Ready Hex	The printer is in Hex Trace mode and is ready to receive and process print jobs.	<ul style="list-style-type: none"> Send a job to print. All data is printed in hexadecimal. Control strings are printed, not executed. Turn the printer off and then on to exit Hex Trace mode.
Remove Paper <specified bin>	The specified output bin is full.	Remove the paper from the specified bin(s).
Resetting Maint Cnt Value	The printer is resetting the counter that tracks wear on the fuser.	Wait for the message to clear.
Resetting the Printer	The printer is resetting to the current default settings. Any active print jobs are canceled.	Wait for the message to clear.
Restore Held Jobs. Go/ Stop?	The printer has been reset or has been turned on and the printer detects print and hold jobs stored on the hard disk.	<p>Press Go. All jobs on hard disk are restored.</p> <p>Press Return or Stop. No jobs are restored and the printer returns to Ready.</p>
Restoring Factory Defaults	The printer is restoring factory default settings.	Wait for the message to clear.
Restoring Held Jobs	The printer is restoring held jobs from the hard disk.	Wait for the message to clear.
Serial <x>	A serial interface is the active communication link.	Wait for the message to clear.
Std Bin Full	The standard bin is full.	Remove the paper in the bin to clear the message.
Supplies	One of the printer supplies requires attention.	Press Menu to open the Supplies Menu and identify which supply item needs replacing.

Message	Meaning	Action
Tray <x> Empty	The specified tray is out of paper.	Load paper in the tray and try to clear the message. If the message cannot be reset, go to “Map 4 - False Tray (x) Low/Empty message” on page 2-56.
Tray <x> Low	The specified tray is low of paper.	Add paper in the tray and try to clear the message. If the message cannot be reset, go to “Map 4 - False Tray (x) Low/Empty message” on page 2-56.
Tray <x> Missing	The specified tray is either missing or not fully inserted.	Insert the tray completely. If the message cannot be reset, go to “Paper tray missing service check” on page 2-83.
Unsupported Disk	The printer detects an unsupported disk.	<ul style="list-style-type: none"> • Press Go to clear the message. • Format the disk.
USB <x>	The printer is processing data through the specified USB port.	Wait for the message to clear.
Waiting	The printer is waiting for an End of Job command, a Form Feed Command, or additional data.	<ul style="list-style-type: none"> • Press Go to print the contents of the buffer. • Press Menu to open the Job Menu and cancel the current job.
1565 Emul Error Load Emul Option	The download emulator version on the firmware card does not match the printer code version.	Download the correct emulator version from Lexmark’s Web site.
2 <xx> Paper Jam	The printer detects a paper jam.	Clear the paper path. If the message cannot be reset, go to the “Paper carrying service check” on page 2-74.

Message	Meaning	Action
30 Coating Roll Missing	The oil coating roll is either missing or installed incorrectly.	Correctly install the oil coating roll. If the message cannot be reset, go to “Map 5 - False 30 Oil Coating Roll Missing message” on page 2-57.
30 <color> Print Unit Missing	One or more of the color print units is either missing or incorrectly installed.	Correctly install the color print unit(s). If the message cannot be reset, go to “Map 6 - False <color> Print Unit Missing message” on page 2-57.
32 Unsupported <color> Cartridge	The printer detects an unsupported toner cartridge.	Replace the cartridge.
33 Tray <x> Config Error	The optional heavy media tray is inserted into any tray location except tray 1.	Remove the heavy media tray from the invalid location.
34 Short Paper	The paper is too short.	<ul style="list-style-type: none"> • Press Go to clear the message. • Make sure the paper size setting in the Paper Menu is correct for the size you are using. • Press Menu to open the Job Menu and cancel the current job.
35 Res Save Off Deficient Memory	The printer lacks the memory to enable Resource Save.	<ul style="list-style-type: none"> • Press Go to disable Resource Save and continue printing. • Install additional memory.
37 Insufficient Collation Area	The printer memory does not have the free space necessary to collate the job.	<ul style="list-style-type: none"> • Press Go to print the portion of the job already stored and begin collating the rest of the job. • Press Menu to open the Job Menu and cancel the current job.

Message	Meaning	Action
37 Insufficient Defrag Memory	The printer cannot defragment flash memory.	<ul style="list-style-type: none"> • Delete fonts, macros, and other data in printer memory. • Install additional printer memory.
37 Insufficient Memory	The printer memory is full and cannot continue processing current jobs.	<ul style="list-style-type: none"> • Press Go to clear the message and continue printing. • Press Stop to clear the message without deleting print jobs. • Press Menu to open the Job Menu and cancel the current job.
38 Memory Full	The printer is processing data, but the memory is full.	<ul style="list-style-type: none"> • Press Go to clear the message and continue printing. • Press Menu to open the Job Menu and cancel the current job.
39 Complex Page	The print information on the page is too complex.	<ul style="list-style-type: none"> • Press Go to clear the message and continue printing. • Press Menu to open the Job Menu and cancel the current job.
4 <x> Unsupported Firmware Card	The printer detects an unsupported version of firmware on the installed firmware card.	<ul style="list-style-type: none"> • Turn the printer off and then press and hold Go while turning it on, bypassing the code on the firmware card. • Remove the firmware card.

Message	Meaning	Action
40 Tray <x> Size Sense Error	The high-capacity feeder detects an error in the size sensing mechanism.	<ul style="list-style-type: none"> • Turn off the printer and be sure that all the high-capacity feeder connectors are installed properly. • Check the high-capacity feeder size sensor and go to “Map 8 - False 40 Tray (x) Size Sensor Error message” on page 2-59.
41 Open Bin 1 Exit Tray	The printer wants to send paper to the bin 1 output tray, but the tray is closed.	<ul style="list-style-type: none"> • Open bin 1 to clear the message. • Press Go to clear the message and continue. If the message cannot be reset, go to “Map 9 - False 41 Open Bin 1 Exit Tray message” on page 2-59.
51 Defective Flash	The printer detects defective flash memory.	<ul style="list-style-type: none"> • Press Go to clear the message and continue printing. • Install different flash memory before downloading.
52 Flash Full	There is not enough free space in flash memory.	<ul style="list-style-type: none"> • Press Go to clear the message and continue printing. • Delete fonts, macros, and other data stored on flash memory. • Install flash memory with more storage capacity.
53 Unformatted Flash	The printer detects unformatted flash memory.	<ul style="list-style-type: none"> • Press Go to clear the message and continue printing. • Format the flash memory. If the error remains, the flash memory may be defective.

Message	Meaning	Action
54 Serial Option <x> Error	The printer has detected a serial interface error on a serial port.	<ul style="list-style-type: none"> • Make sure the serial link is set up correctly and you are using the appropriate cable. • Press Go to clear the message and continue. • Press Menu to open the Job Menu and reset the printer.
54 Network <x> Software Error 54 Standard or Std <x> Software Error	The printer cannot establish communications with an installed network port.	<ul style="list-style-type: none"> • Press Go to clear the message and continue printing. • Program new firmware for the network interface by way of the parallel port. • Press Menu to open the Job Menu and reset the printer.
54 Std Par ENA Connection Lost 54 Par <x> ENA Connection Lost	The printer has lost the connection to an external print server.	<ul style="list-style-type: none"> • Make sure the cable connecting the ENA and the printer is securely attached. Turn the printer off and then on to reset. • Press Go to clear the message and continue printing.
56 Serial Port <x> Disabled	Data has been sent to the printer through a disabled serial port.	<ul style="list-style-type: none"> • Press Go to clear the message. • Make sure the Serial Buffer menu item in the Serial Menu is set to Disabled.
56 Parallel Port <x> Disabled 56 Std Parallel Port Disabled	Data has been sent to the printer through a disabled parallel port.	<ul style="list-style-type: none"> • Press Go to clear the message. • Make sure the Parallel Buffer menu item in the Parallel Menu is set to Disabled.

Message	Meaning	Action
56 USB Port <x> Disabled 56 Std USB Port Disabled	Data has been sent to the printer through a disabled USB port.	<ul style="list-style-type: none"> • Press Go to clear the message. • Make sure the USB Buffer menu item in the USB Menu is set to Disabled.
58 Too Many Bins Attached	Too many output bins are installed. Unsupported output bins are installed.	Turn off and unplug the printer. Remove or reconfigure the output bins. Plug the printer in and turn it on.
58 Too Many Disks Installed	Too many disks are installed.	Turn off and unplug the printer. Remove the excess hard disks. Plug the printer in and turn it on.
58 Too Many Flash Options	Too many flash options are installed.	Turn off and unplug the printer. Remove the excess flash options. Plug the printer in and turn it on.
58 Too Many Trays Attached	Too many trays are installed.	Turn off and unplug the printer. Remove the excess trays. Plug the printer in and turn it on.
61 Defective Disk	The printer detects a defective hard disk.	<ul style="list-style-type: none"> • Press Go to clear the message and continue printing. • Install a different hard disk before you perform any operations that require one.
62 Disk Full	Insufficient memory on the hard disk.	<ul style="list-style-type: none"> • Press Go to clear the message and continue printing. • Delete fonts, macros, and other data stored on the hard disk.

Message	Meaning	Action
63 Unformatted Disk	The printer detects an unformatted hard disk.	<ul style="list-style-type: none"> • Press Go to clear the message and continue printing. • Format the disk before performing disk operations. • Replace the hard disk.
64 Unsupported Disk Format	The printer detects an unsupported disk format.	<ul style="list-style-type: none"> • Press Go to clear the message. • Format the disk.
80 Belt Exhausted	The transfer belt has reached end of life.	Replace the transfer belt.
80 Belt/Fuser Exhausted	The transfer belt and fuser have reached end of life.	Replace the transfer belt and fuser.
80 Belt/Fuser Life Warning	The transfer belt and fuser are nearing end of life.	Press Go to clear the message and continue printing. The supplies message is displayed until you replace the transfer belt and fuser.
80 Belt Life Warning	The transfer belt is nearing end of life.	Press Go to clear the message and continue printing. The supplies message is displayed until you replace the transfer belt and fuser.
80 Fuser Exhausted	The fuser has reached end of life.	Replace the fuser.
80 Fuser Life Warning	The fuser is nearing end of life.	Press Go to clear the message and continue printing. The supplies message is displayed until you replace the transfer belt and fuser.
81 Engine Code CRC Failure	Microcode in the engine flash code module has failed a system check.	Press Go to clear the message and discard the code. Retransmit the microcode data from the host computer.

Message	Meaning	Action
84 All Photo Devs Exhausted	All of the photodevelopers have reached end of life.	Replace all of the photodevelopers. Make sure you also install the new fuser coating roll that is included in each photodeveloper kit.
84 Black Photo Dev Abnormal	The printer has detected an abnormal black photodeveloper.	Install a new black photodeveloper to clear the message and continue printing.
84 Black Photo Dev Exhausted	The black photodeveloper has reached end of life.	<p>Replace the black photodeveloper. Make sure you also install the new oil coating roll that is included in the kit.</p> <p>If print quality is still acceptable and you do not want to replace the photodeveloper, press Go to clear the message and continue printing.</p>
84 Black Photo Dev Life Warning	The black photodeveloper is nearing end of life.	Press Go to clear the message and continue printing. The supplies message is displayed until you replace the photodeveloper.
84 Color Photo Dev Abnormal	The printer has detected an abnormal color photodeveloper.	Install a new color photodeveloper to clear the message and continue printing.

Message	Meaning	Action
84 Color Photo Devs Exhausted	The color photodevelopers have reached end of life.	<p>Replace the color photodevelopers (Cyan, Magenta and Yellow) at the same time.</p> <p>If print quality is still acceptable and you do not want to replace the photodevelopers, press Go to clear the message and continue printing.</p>
84 <Color> Photo Dev Life Warning	The color photodevelopers are nearing end of life.	Press Go to clear the message and continue printing. The supplies message is displayed until you replace the photodevelopers.
85 Toner Empty Coating Roll Exhausted 88 Black Toner Empty	<p>The oil coating roll has reached end of life.</p> <p>The black toner cartridge is empty. See note below.</p>	Replace the oil coating roll and black toner cartridge.
Note: If the customer has replaced the black toner cartridge before this message displays, the oil coating roller message will not display until the cartridge is empty.		
86 Abnormal Coating Roll	Abnormal coating roll Installed.	Replace the coating roll with a valid one to clear this message.
85 Coating Roll Life Warning	Coating roll is nearing it's expected lift.	If the print quality is still good, press Go to continue. Otherwise, replace the oil coating roll.
84 <color> Photo Dev Abnormal	Abnormal photodeveloper installed	Install correct photodeveloper.

Message	Meaning	Action
Replace Oil Coating Roll	A new black toner cartridge has been installed. This is a reminder to install a new oil coating roll.	Press Go to clear or replace the oil coating roll with a new one.
88 <color> Toner Empty	The printer has ceased operating because the specified toner cartridge is empty.	Install a new toner cartridge and go to “Map 7 - False 88 <color> Toner Low/Toner Empty message” on page 2-58.
88 <color> Toner Low	The printer has detected that the specified toner cartridge is low.	<ul style="list-style-type: none"> • Replace the specified toner cartridge. • Press Go to clear the message and continue printing. The supplies message is displayed until you replace the specified toner cartridge. Go to “Map 7 - False 88 <color> Toner Low/Toner Empty message” on page 2-58.

Clearing finisher messages

Message	Solution
Bin <x> Full	Remove the stack of paper from the bin to clear the message. If you assigned the bin a name, the bin name is displayed instead of the bin number. Press Go to clear the message and continue printing.
Check Finisher Installation	Make sure the finisher is flush against the printer. If this does not resolve the problem, go to “ Finisher service check ” on page 2-71 to check the finisher set switch.
Close Finisher Top Cover	Close the finisher top cover and align the finisher flush against the printer to clear the message.
Empty Box	Empty the hole punch box to continue printing.
Leave Staple Job in Finisher	The printer has detected a paper jam while printing a job that must be stapled. The message Leave Staple Job in Finisher alternates with the Paper Jam message. Leave the printed pages on the stacking tray inside the finisher and clear the paper jam in the printer. Press Go to clear the message and continue printing.
Staples Empty	Replace the staple cartridge if you want to continue stapling. You can press Go to clear the message and continue printing without stapling.
Stapler Missing	The staple holder is missing. Place the staple holder in the stapler to clear the message. Go to “ Finisher service check ” on page 2-71 to check the no staple sensor.
Insert Hole Punch Box	Install the hole punch box. The printer will automatically clear the message. Go to “ Finisher service check ” on page 2-71 to check the punch box detect sensor.

Message	Solution
Insert Staple Cartridge	The staple cartridge is either missing or installed incorrectly. Correctly install the staple cartridge. Go to “Finisher service check” on page 2-71 to check the staple cartridge set sensor.
210 Staple Jam	Open the finisher stapler door, remove the paper from the accumulator, and remove the staple jam. Go to “210 Staple jam service check” on page 2-86.

Maintenance analysis procedures (MAPS)

Map 1 - False Side Door Open message

Step	Questions/actions	Yes	No
1	Close the side (turn guide) door. Does the message reset?	Problem solved.	Go to step 2.
2	Disconnect CN30 from the printer controller board. While activating the door switch, is there continuity at pins 1 and 2 of the connector?	Replace the printer controller board.	Replace the side door (turn guide) sensor assembly.

Map 2 - False Close Front Door message

Step	Questions/actions	Yes	No
1	Close the top unit and front cover. Does the message reset?	Problem solved.	Go to step 2.
2	Is the interlock switch actuator broken?	Replace the front door.	Go to step 3.
3	Is the actuator rod that activates the interlock switch on power supply 2 damaged or broken?	Replace the actuator rod.	Replace the power supply 2.

Map 3 - False Close Tray (x) Top Cover message

Step	Questions/actions	Yes	No
1	Remove the rear cover on the high-capacity feeder and observe LED 9 on the HCF card while actuating the cover open micro-switch. Does the LED go on and off, while opening and closing the door?	Replace the HCF card.	Replace the cover open micro-switch.

Map 4 - False Tray (x) Low/Empty message

Step	Questions/actions	Yes	No
1	Is the "Tray x Low" message present?	Go to step 2.	Go to step 5.
2	Is the paper remaining actuator inside the cassette drawer binding, or operating incorrectly?	Go to step 3.	Repair or replace the cassette.
3	Are connectors CN35 and CN36 on the printer controller board, and CN10 on the expansion feeder control card associated with the failing tray properly connected?	Go to step 4.	Properly connect the connectors.
4	Replace the paper remaining sensor board for the problem tray. Does this fix the problem?	Problem solved.	Replace the expansion feeder control card.
5	Is the paper present flag operating correctly?	Go to step 6.	Repair or replace the failing parts.
6	Are connectors CN35 and CN36 on the printer controller board, and CN6 on the expansion feeder control card associated with the failing tray properly connected?	Go to step 7.	Properly connect the connectors.
7	Replace the paper present sensor. Does this fix the problem?	Problem solved.	Replace the associated expansion feeder control card.

Map 5 - False 30 Oil Coating Roll Missing message

Step	Questions/actions	Yes	No
1	Is the OCR properly installed?	Go to step 2.	Properly install the OCR.
2	Is the OCR fuse missing?	Replace the OCR	Go to step 3.
3	Is the OCR contact at the rear of the fuser damaged or broken?	Replace the fuser.	Go to step 4.
4	Is CN44 on the printer controller board properly connected?	Replace the printer controller board.	Properly connect CN44.

Map 6 - False <color> Print Unit Missing message

Step	Questions/actions	Yes	No
1	Are all connectors that the print unit photodeveloper contacts when the top cover is closed operating correctly and not damaged, worn, or missing?	Go to step 2.	Replace the sub frame.
2	Is CN42 on the printer controller board properly connected?	Replace the printer controller board.	Properly connect CN42.

Map 7 - False 88 <color> Toner Low/Toner Empty message

Step	Questions/actions	Yes	No								
1	<p>Ensure the RIP board and the printer controller board are updated to the latest code (Microcode EC2 or higher).</p> <p>Are the boards at EC2 or higher?</p>	Go to step 2.	Upgrade the RIP and controller board codes to the latest level.								
2	<p>Ensure that the encoder located at the rear of the toner set is clean and free of dirt or paper dust.</p> <p>Is the encoder wheel clean and free of dirt or paper dust?</p>	Go to step 3.	Clean the encoder wheel or replace the toner set.								
3	Is the toner remaining photo interrupter sensor clean and free of obstructions?	Go to step 4.	Clean or replace the toner remaining photo interrupter.								
4	<p>Is the connector of the problem color properly connected on the printer controller board?</p> <table border="1" data-bbox="226 1068 471 1206"> <tbody> <tr> <td>Magenta</td> <td>CN18</td> </tr> <tr> <td>Yellow</td> <td>CN21</td> </tr> <tr> <td>Cyan</td> <td>CN19</td> </tr> <tr> <td>Black</td> <td>CN22</td> </tr> </tbody> </table>	Magenta	CN18	Yellow	CN21	Cyan	CN19	Black	CN22	Replace the printer controller board.	Properly connect the connector.
Magenta	CN18										
Yellow	CN21										
Cyan	CN19										
Black	CN22										

Map 8 - False 40 Tray (x) Size Sensor Error message

Step	Questions/actions	Yes	No
1	On the high-capacity feeder, are the paper size adjusting screws present on the upper portion of the side fence and fully screwed into the adjusting bracket?	Go to step 2.	Replace the missing thumbscrew or screw them in all the way.
2	Observe the LEDs 1 and 2 on the HCF control board while unscrewing the paper size adjusting thumbscrews. Do the LEDs light when the screws are loosened all the way?	Replace the HCF control board.	Replace the affected sensor. Paper size sensor 1 for 11 inch or paper size sensor 2 for A4.

Map 9 - False 41 Open Bin 1 Exit Tray message

Step	Questions/actions	Yes	No
1	Is the exit tray switch actuator broken or damaged?	Replace the paper exit tray.	Go to step 2.
2	Disconnect CN31 from the printer controller board. When activating the paper exit tray switch, is there continuity between pins 1 and 2?	Replace the printer controller board.	Replace the paper exit tray switch.

Map 10 - Unrecoverable Check Tray (x) or Duplex Connection message

Step	Questions/actions	Yes	No
1	Is the problem with a specific paper tray or the duplex unit?	Go to step 2.	Go to step 8.
2	Is the problem with tray 1?	Go to step 3.	Go to step 6.
3	Are connectors CN 35 and CN36 on the printer controller board properly connected?	Go to step 4.	Properly connect the connectors.
4	Are connectors CN3 and CN1 on the expansion paper feed control card, for tray 1, properly connected?	Go to step 5.	Properly connect the connectors.
5	Replace the tray 1 expansion feeder control card. Does this fix the problem?	Problem solved.	Return the tray 1 expansion feeder control card and replace the printer controller board. If the problem remains, replace the expansion feeder cable assembly.
6	Are connectors CN9, CN8, CN7 and CN3 on the expansion feeder control card (for the problem tray and the trays above and below) properly connected?	Go to step 7.	Properly connect the connectors.
7	Exchange the expansion feeder control board for the problem tray with one above or below. Does the symptom follow the exchanged card?	Replace the defective expansion feeder control card.	Replace the upper and lower expansion paper feed drawer connecting cable assemblies.

Step	Questions/actions	Yes	No
8	Are any of the pins or contacts on the duplex drawer connectors bent or damaged?	Go to step 9.	Repair or replace the connector.
9	Are connectors CN101 and CN102 on the duplex interface card properly connected?	Go to step 10.	Properly connect the connectors.
10	Replace the duplex interface card. Does this fix the problem?	Problem solved.	Return the duplex interface card and go to step 11.
11	Replace the duplex interface cable. Does this fix the problem?	Problem solved.	Go to step 12.
12	Are CN37 and CN38 on the printer controller board properly connected?	Replace the printer controller board. If the problem remains, replace the duplex connector cable.	Properly connect the connectors.

Map 11 - Paper size map

Step	Questions/actions	Yes	No
1	Do the paper size sensor actuators on the paper operation tray operate correctly, as you slide the paper location plate?	Go to step 2.	Replace parts as necessary.
2	Do the size sensor levers operate correctly?	Go to step 3.	Replace the size sensor levers.
3	<p>Are the following connectors properly connected?</p> <p>CN2 (tray 1) on the printer controller board.</p> <p>CN4 on the expansion feeder control card (trays 2–5).</p>	Go to step 4.	Properly connect the connectors.
4	Replace the paper size sensor card. Does this fix the problem?	Problem solved.	<p>Replace the printer controller board (tray 1).</p> <p>Replace the expansion feeder control card (trays 2–5).</p>

Symptom table

Symptom	Action
You cannot print color.	<p>Make sure the Color Correction menu item is not set to Black & White.</p> <p>Make sure the color print units are completely installed in the printer.</p> <p>Go to the “Transfer belt up/down service check” on page 2-87.</p>
Transparencies curl excessively.	<p>Make sure you're using the recommended Lexmark transparencies. Also be sure the paper delivery is set to the rear exit.</p>
The printer seems slow to print.	<p>If you set the Paper Type to Transparency or Card Stock, the printer increases the fuser temperature and slows printing to improve the print quality. After printing on these media, the printer requires additional time to cool the fuser after you select another Paper Type setting (such as Plain Paper or Letterhead).</p> <p>If Printer Usage is set to Maximum Yield, the printer calibrates the print head timing. The printer performs this same calibration each time you turn the printer on and each time you open and close the top cover. Depending on the types of jobs you print, these adjustments may significantly slow print time.</p>
You cannot remove paper jammed in the fuser.	<p>Open the fuser rollers by operating the fuser pressure relief lever. If you cannot remove the jam, replace the fuser.</p>
You cannot clear the paper jam message.	<p>To clear the paper jam messages, you must remove all paper from the printer paper path. Check both inside the printer as well as the paper source you were using. Open and close the front cover and press Go. If the message does not clear, go to “Paper carrying service check” on page 2-74.</p>
Paper jam in pick-up assembly.	<p>Go to the “Paper carrying service check” on page 2-74.</p>

Symptom	Action
Fuser failure.	Go to the “920 - Fuser Error—Fuser Heater Trouble” on page 2-6.
No paper pick-up from multipurpose tray.	Go to the “Paper carrying service check” on page 2-74.
No paper pick-up from upper or lower cassettes.	Go to the “Paper carrying service check” on page 2-74.
Registration roller does not rotate.	Go to the “Paper carrying service check” on page 2-74.
Operator panel does not operate properly.	<p>Go to the Diagnostic aids chapter and run the LCD and Button tests. If the tests fail, replace the operator panel. If you still have a problem, replace the RIP controller board.</p> <p>If your machine beeps 5 times and the screen is blank or all diamonds, replace the operator panel.</p>
<ul style="list-style-type: none"> • Foggy print • Black pages • Blank print • White spots • Poor reproduction • Incorrect color image registration • Dirt on back of paper • Low image density • White and black lines and bands 	Go to “Print quality problems” on page 2-88.

Symptom	Action
Evenly spaced marks on the paper, or a single mark in the same place on every page.	Go to the “Transfer belt up/down service check” on page 2-87.
Poor fusing.	Go to the “920 - Fuser Error—Fuser Heater Trouble” on page 2-6.
Toner scatter on front or back of paper.	<p>Check the following:</p> <ul style="list-style-type: none"> • Excessive toner buildup on the transfer belt. Clean off the toner and run a test print. • Transfer belt assembly • Transfer belt toner waste bottle • Transfer belt separation fingers • Fuser separation pawl
Paper will not feed from MPF.	<p>Be sure you have paper in the MPF.</p> <p>Be sure the MPF paper present sensor connector (CN11) is connected to the printer controller board. If the paper still does not feed, go to the “Paper carrying service check” on page 2-74.</p>

Finisher

Use the following table to find solutions to problems with the optional finisher.

Symptom	Cause	Solution
<p>Paper frequently jams in the finisher.</p>	<p>The finisher and printer are misaligned.</p> <p>The printer and finisher have been moved.</p> <p>Attempting to staple, hole punch, or offset print jobs on print media other than paper.</p>	<p>Paper frequently jams in the finisher. Properly align the finisher with the printer. Align the top of the guide rail with the line on the holding plate by rotating the two alignment knobs closest to the holding plate. This action raises or lowers the guide rail, depending on which way the knobs are turned. The edge of the guide rail should line up with the sticker where the white and gray portions divide.</p> <p>Restrict use of the finisher to plain paper. You cannot hole punch transparencies, card stock, labels, or envelopes.</p>
<p>Printer only prints to bin 1 or bin 2.</p>	<p>The finisher cables are not connected properly.</p> <p>The printer driver and the operator panel settings are different.</p>	<p>Check the cable connections.</p> <p>Make sure your printer driver is set to direct the output to the bin you want.</p> <p>Printer settings selected from a software application or driver override default settings selected from the operator panel.</p>

Symptom	Cause	Solution
You cannot clear the paper jam message.	The cover is not closed, finisher is against the printer, or there is paper somewhere in the paper path.	Open and close the top cover and make sure the finisher is locked onto the alignment pins. Recheck the finisher and printer for additional jams.
Pages are not stapled.	Attempting to staple too many sheets.	Reduce the number of pages in the staple job. The finisher can staple up to 30 sheets of 20 lb paper. If you attempt to staple a larger stack of paper, the finisher ejects the stack without stapling it.
	The staple cartridge is empty.	Install a new staple cartridge.
	The stapler is jammed.	Check the stapler for a staple jam.

Service checks

Drive 1 DC motor service check

	FRU	Action
1	<ul style="list-style-type: none"> • DC motor • Drive unit 1 • Printer controller board 	<p>If the motor does not attempt to turn and you receive a 910 error code, replace the driver 1 dc motor.</p> <p>Be sure the toner and photodeveloper units are not causing an overload on the dc motor.</p> <p>If the motor turns but the paper carrying section of the machine does not rotate, check the drive 1 unit gear train for damage. Be sure the clutch on the gear train engages for color printing. Replace the drive 1 unit if necessary.</p> <p>If this does not correct the problem, replace the printer controller board.</p>

Drive 2 stepper motor service check

	FRU	Action
1	Drive 2 stepper motor	Be sure connector CN4 on the printer controller board is firmly connected. If there still is a problem, replace the drive 2 stepper motor.

Duplex unit service check

	FRU	Action
1	Feed roller belts	Check for wear or damage to the feed roller belts. Replace as necessary.
2	<ul style="list-style-type: none"> • Duplex stepper motor • Side fence • Stepper motor gears 	<p>Be sure the stepper motor turns freely with no binding.</p> <p>Check for wear or damage to the associated gears.</p>
3	<ul style="list-style-type: none"> • Feed roller solenoid assembly • Paper re-feed solenoid assembly 	Check for proper operation of the solenoid and linkage. Replace as necessary.
4	Photo-interrupter assembly	Ensure that the photo-interrupter actuators are operating correctly and are in the proper position.

Expansion paper feed service check

If you have a “200 Paper Jam Tray (x)” error code, check the option connection cable for proper connection to the printer or other paper feeder.

	FRU	Action
1	Feeder drive motor	If the feeder drive motor works, go to the “Paper carrying service check” on page 2-74.
2	<ul style="list-style-type: none"> • Gears • Feeder solenoid • Paper feed clutch • Expansion feeder control board 	If the motor turns but the drive gears do not, replace the gears as necessary. Check the feeder solenoid and paper feed clutch for proper operation, and replace as necessary. If this does not correct the problem, replace the expansion feeder control board.

Face down stacker full service check

	FRU	Action
1	Stacker full detection lever	Check the stacker full detection lever for damage.
2	<ul style="list-style-type: none"> • Stacker full detection sensor • Printer controller board 	Check for a voltage fluctuation between 0 V and +5 V between pins 2 and 3 of connector CN9 on the printer controller board while actuating the sensor.

High-capacity feeder (HCF) service check

	FRU	Action
1	<ul style="list-style-type: none"> • Paper size sensors 1 and 2 • Residual paper sensors 1–4 • Paper level sensor • Lower limit switch • Docking switch • Upper limit • Paper sensor switch • Paper feed sensor 	Go to the “High-Capacity Paper Feed Sensor / Switch Test” on page 3-19 , and perform the LED sensor test. You can block each sensor to verify if it is working properly. Replace the failing sensor.
2	<ul style="list-style-type: none"> • Tray motor • Paper feed motor • HCPF power supply • Pickup solenoid • Paper feed roller • Transfer roller • Paper feed clutch • Tray drive belt 	Be sure that all rollers, gears, and belts are in good working order. Replace as necessary.
3	<ul style="list-style-type: none"> • Paper feed clutch • Pickup solenoid • HCF power supply • Paper feed motor • Tray motor • HCPF board 	Go to the “Maintenance Mode” on page 3-60 and run the tests.

Finisher service check

	FRU	Action
1	<ul style="list-style-type: none"> • Input path sensor • Paper register sensor • Upper tray exit sensor • Guide stack assembly • Paper full A sensor • Paper detect sensor • Staple home position sensor • No staple sensor • Punch box detect sensor • Invert path sensor • Lower tray exit sensor • Elevator upper limit sensor • Tray near full sensor • Elevator lower limit sensor • Jogging assembly • Pap. upper level sensor • Fin. set switch sensor • Staple cart. set sensor 	<p>Note: For frequent jams, hole punch problems or stapling problems. First check the finisher to printer alignment. Go to “Aligning the finisher and printer” on page 3-80.</p> <p>Run the finisher sensor test in diagnostic mode to test the sensors and switches.</p>
2	<ul style="list-style-type: none"> • Timing belts • Patting roller • Path select solenoid • Path select gate • Guide stack assembly • Jogging unit assembly • Tractor drive assembly • Stapler 	<p>Run the staple test in diagnostic mode to test feeding and stapling function.</p>

	FRU	Action
3	<ul style="list-style-type: none"> • Registration roller • Paper exit rollers • Registration sensor • Registration clutch • Punch clutch punch unit • Timing belt 	Run the hole punch test in diagnostic mode to test the hole punch function.
4	<ul style="list-style-type: none"> • Elevator motor • Tray wires 	Observe the elevator motor operation while powering the printer up.

Marks on paper service check

If you have evenly spaced marks on the paper, measure the distance between the marks and locate the symptom below. Check the assembly for dirt or damage and clean as necessary. Run a test print to verify the problem has been corrected. The indicated assemblies are replaced by the customer at prescribed intervals.

If you remove the transfer belt, do not turn it upside down. Toner will fall from the waste toner box onto the transfer sheets and roller(s) inside the belt. This causes lower transfer efficiency and washed out colors.

Distance between marks	FRU / supply item
27 mm	Absorption/charge roller (transfer roller)
31.5 mm	Photodeveloper charge roller
45.1 mm	Supply roller (toner cartridge)
46.9 mm	Upper registration roller
46.9 mm	Lower registration roller
47.5 mm	Developer roller (toner cartridge)
64.5 mm	OCR (oil coating roller)
94.2 mm	Photodeveloper drum
139.2 mm	Fuser upper roller

Distance between marks	FRU / supply item
140 mm	Fuser lower roller
824.5 mm	Transfer belt

Fuser part locations	From paper center (mm)
Thermistor hot roll	-6
Thermistor BUR	0
TCO hot roll	66
TCO BUR	101
Detact fingers hot roll	113.5/75/37.5/0/-37.5/-75/-113.5
Detact fingers BUR	134/90/45/0/-45/-90/-134
Exit rollers	96/37.5/-37.5/-96
Star rollers	127/60/15/-15/-60/-127

Operator panel service check

	FRU	Action
1	<ul style="list-style-type: none"> • Operator panel • Operator panel cable • RIP board. Make sure code is at least EC2 or later. 	<p>Run both the LCD Hardware Test and the Button Test in Diagnostic Mode.</p> <p>Be sure the operator panel cable connections are securely connected on the RIP board and operator panel.</p>

Paper carrying service check

Paper has not exited or is stopped in the high-capacity feeder (area F, 249).

	FRU	Action
1	<ul style="list-style-type: none"> Paper feed roller Transfer roller 	Be sure the paper feed roller transfer roller, reverse roller, and call roller are free of dirt and are not damaged. Clean or replace parts as necessary.
2	<ul style="list-style-type: none"> Paper feed clutch Paper feed motor Sensors 	<p>Set up and run a test in Maintenance Mode and go to the “High-capacity feeder (HCF) service check” on page 2-70.</p> <p>Ensure all motors, clutches, and sensors operate correctly.</p>
3	<ul style="list-style-type: none"> HCPF control card HCPF power supply 	<p>Set up and run a test in Maintenance Mode and go to the “High-capacity feeder (HCF) service check” on page 2-70.</p> <p>If no LEDs light, check the power source. Replace the HCF control card. Replace the HCF power supply.</p>

Paper is being picked up and carried to the registration roller (areas C, E, 240, 24x).

	FRU	Action
1	Paper feed cassette	Be sure the paper cassette has the size guides and the side locator locks are working properly. Replace parts as necessary.
2	<ul style="list-style-type: none"> • Paper feed roller (MPF) • Paper feed rolls MPF, tray 1, 2, 3, 4, 5 • Carrying roller tray 1, 2, 3, 4, 5 • Fanning pad (MPF) 	Be sure the paper feed rollers are free of dirt and not damaged. Be sure the fanning pad is free of dirt and not damaged. Replace parts as necessary.
3	Gears	Be sure the paper feed gears are not damaged.
4	<ul style="list-style-type: none"> • Paper feed solenoid • Paper feed clutch • MPF clutch • MPF frame assembly 	Be sure the paper feed solenoid activates the paper feed clutch and the clutch engages properly. Check the failing paper feed solenoid for continuity. Also check connector CN24 (tray1) and CN16 (MPF) on the printer controller board and CN5 on the expansion feeder control card.
5	<ul style="list-style-type: none"> • Registration sensor • MPF sensor • Printer controller board 	Check for a fluctuation between 0 and +5 V on the printer controller board between the following pins, when actuating the sensor: <ul style="list-style-type: none"> • Registration sensor—CN11 (pins 1 and 2) • MPF sensor—(CN11 pins 4 and 5) If the voltage fluctuates as stated above, replace the printer controller board. If the voltage does not fluctuate, replace the sensor.

Paper has stopped at the registration roller or has not reached the fuser (areas C, E, 240, 24x).

	FRU	Action
1	<ul style="list-style-type: none"> • Registration roller clutch • Registration roller • Transfer belt unit • Rear paper feed guide 	<p>Check these parts for wear or damage. Replace as necessary. Be sure all guide surfaces in the paper path are free of dirt.</p> <p>Check the registration roller clutch for continuity.</p> <p>Be sure connector CN13 on the printer controller board is connected properly.</p>
2	<ul style="list-style-type: none"> • Registration sensor • Printer controller board 	<p>Check for a fluctuation of between 0 V and +5 V between pins 1 and 2 of connector CN11 on the printer controller board while actuating the sensor. If the voltage fluctuates as stated above, replace the printer controller board. If the voltage does not fluctuate, replace the sensor.</p>

Paper has exited the registration roller and entered the fuser (areas A and B).

	FRU	Action
1	<ul style="list-style-type: none"> • Transfer belt unit • Rear paper guide • Discharge brush • Fuser 	<p>Remove any buildup of toner. Replace any damaged or worn parts.</p> <p>Check the paper exit flag on the fuser for damage. Replace the fuser if necessary.</p>
2	Fuser separation pawl	Replace the fuser if paper jams cannot be removed.

Paper has entered the fuser and exited the printer (area B).

	FRU	Action
1	Fuser	Remove any toner buildup and replace any worn or damaged parts.
2	<ul style="list-style-type: none"> • Fuser exit lower roller • Fuser exit upper roller • Face up exit assembly 	<p>Be sure the exit FU/FD solenoid energizes in the correct position for either face down or face up delivery.</p> <p>Do a continuity check of the solenoid. Be sure connector CN122 is properly connected to the printer controller board.</p>
3	<ul style="list-style-type: none"> • Face down exit assembly • Face down feed roller belt 	<p>Be sure that connector CN4 is properly connected to the controller board.</p> <p>Check the face down feed roller belt.</p> <p>Check for a fluctuation of between 0 V and +5 V on the printer controller board between the following pins, when actuating the sensor:</p> <ul style="list-style-type: none"> • Paper exit switch—CN12 (pins 4 and 5) • Face up/face down sensor—(CN12 pins 1 and 2)

Paper has entered the duplex unit (area D).

	FRU	Action
1	Feed rollers Belts	Check for wear or damage to feed rollers and belts.
2	Duplex unit	Be sure the duplex unit is properly installed and that all connections are correct.
3	<ul style="list-style-type: none"> • Duplex stopper motor • Side fence stepper motor 	<p>Be sure the stepper motor turns freely with no binding.</p> <p>Check for wear or damage to the associated gears. Replace as necessary.</p>
4	<ul style="list-style-type: none"> • Feed roller solenoid assembly • Paper re-feed solenoid assembly 	Check for proper operation of the solenoid and linkage. Replace as necessary.
5	Paper tray	Check to see if the paper edge guides have shifted. If so, re-time by removing the screw and gear from the bottom of the tray and pushing the paper edge guides up against the paper lift plate. Reinstall the screw and gear.

Paper jammed in finisher (area G).

	FRU	Action
1	<ul style="list-style-type: none"> • Registration roller • Paper exit rollers • Registration sensor • Registration clutch • Punch clutch punch unit 	<p>Check finisher to printer alignment. Go to “Aligning the finisher and printer” on page 3-80.</p> <p>Check all belts for wear or damage. Check the registration roller for wear or damage.</p> <p>Check for obstructions.</p> <p>Check the registration sensor by running the finisher sensor tests in diagnostic mode.</p> <p>Check the registration clutch by running the staple test or hole punch test in diagnostic mode. Replace parts as necessary.</p>
2	<ul style="list-style-type: none"> • Paper feed motor • Finisher control board 	<p>Check the paper feed motors by running the staple test or hole punch test in diagnostic mode.</p> <p>If the paper feed motor has been replaced, replace the finisher control board.</p>

Paper jammed in finisher (area H).

	FRU	Action
1	<ul style="list-style-type: none"> • Timing belts • Patting roller 	<p>Check finisher to printer alignment. Go to “Aligning the finisher and printer” on page 3-80.</p> <p>Check for obstructions in the paper path. Check all belts for wear or damage.</p> <p>Check for wear or damage on the patting roller.</p>
2	<ul style="list-style-type: none"> • Path select solenoid • Path select gate • Guide stack assembly • Jogging assembly • Stapler 	<p>Check for proper operation of the guide stack assembly and jogging assembly by running the staple test in diagnostic mode. Check the tractor belts for proper alignment.</p> <p>Replace parts as necessary.</p>
3	<ul style="list-style-type: none"> • Belt home position sensor • Paper detecting sensor • Invert path sensor • Finisher control board 	<p>Ensure that all sensors are operating properly by running the sensor test in diagnostic mode.</p> <p>Replace sensors as necessary.</p>

Paper jammed (area I).

	FRU	Action
1	Timing belts	<p>Check finisher to printer alignment. Go to “Aligning the finisher and printer” on page 3-80.</p> <p>Check the paper path for obstructions. Check all belts for wear or damage.</p>
2	<ul style="list-style-type: none"> • Invert (tray 2) exit roller • Exit guide (tray 2) invert assembly • Exit guide (tray 1) straight assembly 	Check to ensure that all rollers are operating correctly by running the hole punch and staple tests in diagnostic mode.
3	<ul style="list-style-type: none"> • Paper exit sensor (tray1) • Paper exit sensor (tray 2) • Paper full sensor A (tray 2) • Paper upper level sensor B (tray 2) 	Ensure that the sensors are working properly by running the sensor test in diagnostic mode.
4	<ul style="list-style-type: none"> • Elevator upper limit sensor • Elevator lower limit sensor • Elevator motor 	Ensure that the elevator upper limit sensor, elevator lower limit sensor, and the elevator motor are operating correctly at power up.

Paper exit, face up service check

	FRU	Action
1	Face up exit assembly	<p>If the paper is not exiting to the back paper face up tray or the face down tray, check the sensor for proper operation by checking for a fluctuation of between 0 V and +5 V between pins 1 and 2 of connector CN12, while actuating the sensor.</p> <p>Check the FU/FD deflector that directs the paper to the proper tray.</p> <p>Check the FU/FD solenoid for continuity. Also be sure the connector is properly connected to the printer controller board.</p> <p>Check the gears and the actuating mechanism for wear or damage.</p>
2	Printer controller board	Check connectors CN2 and CN14 for proper connection on the printer controller board.

Paper skew service check

	FRU	Action
1	Cassette	<p>Remove the tray and turn it upside down. The tray guides are connected at the center of the tray by a toothed gear that ensures they move in unison. If not, remove the screw at the center of the gear and, using a sheet of paper in the tray as a template, realign the guides.</p> <p>Reseat the roller at the leading edge of the transfer belt.</p> <p>Make sure the correct amount of paper is in the tray and that it is under the corner bucklers.</p> <p>The paper lift tray must be pushed down to the lock position every time the drawer is closed.</p>

Paper tray missing service check

	FRU	Action
1	<ul style="list-style-type: none"> • Size sensor actuators • Cassette 	<p>Check to ensure that the paper size adjustment is correct for the paper being used. Ensure that the paper size sensor actuators are not bent or broken. Make sure that there are no broken parts on the cassette that would allow the cassette to move or shift from its intended position inside the printer.</p>
2	<ul style="list-style-type: none"> • Size sensor board • Expansion paper feeder control board • Printer controller board 	<p>Be sure that connector CN2 on the printer controller board is connected properly. Also check CN4 on the expansion paper feeder control board for the associated tray.</p>

Photodeveloper missing service check

When you replace the photodeveloper unit, all three color units must be replaced at the same time.

	FRU	Action
1	Photodeveloper	Check for dirt or damage to the sensing contacts on rear. Clean or replace the photodeveloper drum unit if necessary.
2	Sub-frame unit	Check the sensing contacts on the sub-frame assembly. Clean or replace the affected contacts or sub-frame.
3	High voltage unit	If the problem remains, replace the high voltage unit (HVU).
4	Printer controller board	If the problem remains, replace the printer controller board.

Power supply service check

	FRU	Action
1	Voltage	Be sure the switch is on and the power cord is firmly plugged into the printer. Be sure the correct voltage is present at the outlet.
2	Power cord	Check the power cord for continuity.
3	<ul style="list-style-type: none"> • Fuse • Switch • Power supply 1 	The power supply fuses may be blown. Unplug the machine and check fuse F2 on the power supply 1 for continuity. If the fuse is good, check the power switch connector for continuity.
4	Power supply 2	<p>The power supply 2 may be defective.</p> <p>Check the dc power of the power supply for the following pins:</p> <p style="padding-left: 40px;">CN102 pins 8 and 11 for +3.3 V CN103 pins 7 and 14 for +3.3 V CN105 pin 5 for +3.3 V</p> <p style="padding-left: 40px;">CN102 pins 12 and 14 for +5 V CN103 pins 1, 3, 8, 9 for +5 V CN104 pins 1 and 2 for +5 V</p> <p style="padding-left: 40px;">CN104 pins 7 and 8 for +24 V CN105 pin 4 for +24 V CN106 pins 5 and 6 for +24 V</p> <p>Replace power supply 2 if necessary.</p>

210 Staple jam service check

	FRU	Action
1	Stapler Staple cartridge holder	Check for jammed staples in the stapler. Clear the staple jam, go into diagnostic mode, and run a staple test. If the problem reoccurs, replace the staple cartridge holder. If this does not resolve the problem, replace the stapler.
2	Stapler Finisher control board Stapler cable	If the error occurs and there is no staple jam, check to ensure that connectors CN5 on the stapler and PJ1 on the finisher control board are properly connected. Make sure that the finisher set switch is activated. Measure for +5 V dc between pins 11 and 12 on stapler connector CN5. If +5 V dc is not present, check for continuity on the stapler to finisher control board cable. If there is no continuity on any pin position, replace the cable. If there is continuity, replace the finisher control board. If +5 V dc is present, replace the stapler.



Transfer belt up/down service check

	FRU	Action
1	Belt up/down sensors Belt up/down actuator	Check the transfer belt up/down sensor. Be sure that connector CN29 is firmly connected to the printer controller board. Replace the sensor or the actuator if necessary. Check for a fluctuation between 0 V and +5 V between pins 8 and 10, while actuating the sensor.
2	Belt up/down clutch	Be sure connector CN26 is firmly connected to the printer controller board. Replace the belt up/down unit if necessary.
3	Belt up/down lift cams	Check and replace the belt up/down lift cam shaft if necessary.
4	Printer controller board	If there still is a problem, replace the printer controller board.

Image quality troubleshooting

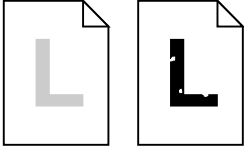
Print quality problems

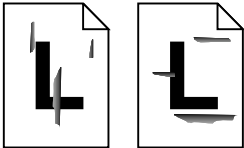
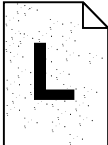
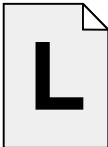
Problem	Action
<p>Print is too light, or printed images or characters have voids or dropouts.</p> 	<p>Be sure you're using recommended paper or other media. Use media from a new package.</p>
	<p>Be sure you have selected the correct Paper Weight setting for the media you're using.</p>
	<p>Be sure the affected print unit is completely installed in the printer.</p>
	<p>Set print darkness to 4 from the Color Menu.</p>
	<p>Clean the printhead LEDs.</p>
	<p>If you suspect a toner cartridge is low on toner, remove the appropriate toner cartridge and gently shake it back and forth to distribute the toner evenly. Reinsert the print unit and try printing the job again.</p>
	<p>Replace the affected toner cartridge.</p>
<p>Replace the photodevelopers. If only black print appears light, replace just the black photodeveloper. If one of the colors prints too light, replace all three of the color photodevelopers. If there is still a problem, go to “Uneven printing” on page 2-97.</p>	

Problem	Action
<p>Colored lines, streaks, or smudges appear on the printed page, or print appears blurred or unclear.</p> 	<p>Replace the photodevelopers. If the problem only occurs when printing black, replace just the black photodeveloper and fuser coating roll. If the problem occurs when printing one of the colors, replace all three of the color photodevelopers. If the problem remains, go to “Black line” on page 2-95.</p>
<p>Toner specks appear on the page.</p> 	<p>Replace the oil coating roll.</p>
<p>Toner colors the background of the page.</p> 	<p>Be sure the affected photodevelopers and toner cartridges are completely installed in the printer.</p>
<p>The page has 100% coverage of one color.</p> 	<p>Be sure the affected photodevelopers are completely installed in the printer.</p> <p>Replace the photodevelopers. If the page is black, replace just the black photodeveloper. If the page is another color, replace all three of the color photodevelopers. If this does not fix the problem, go to “Black print” on page 2-95.</p>

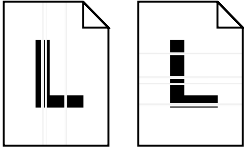
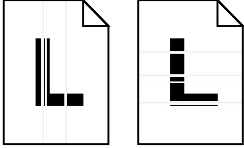
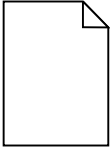
Problem	Action
<p>Light lines or streaks appear on the printed page.</p> 	<p>Clean the LEDs.</p> <p>Make sure the affected photodeveloper is completely installed in the printer.</p> <p>Remove the affected toner cartridge and gently shake it back and forth to distribute the toner evenly. Reinsert the toner cartridge and try printing the job again.</p> <p>Replace the affected toner cartridge.</p> <p>Replace the photodevelopers. If the problem only occurs when printing black, replace just the black photodeveloper. If the problem occurs when printing one of the colors, replace all three of the color photodevelopers and the transfer belt. If the problem remains, go to “Uneven printing” on page 2-97.</p>
<p>Cyan dots or streaks in area of like cyan coverage.</p> 	<p>Make sure the printer code is at EC2 level or later.</p>
<p>The page is blank.</p> 	<p>Be sure the affected print unit is completely installed in the printer.</p> <p>Replace the affected toner cartridge. If the problem remains, go to “No image” on page 2-94.</p>

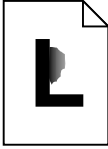
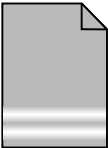
Problem	Action
<p data-bbox="128 207 437 261">Toner smears or rubs off the page.</p> 	<p data-bbox="511 207 894 261">Be sure you're using recommended paper or media.</p>
	<p data-bbox="511 285 953 367">Be sure you have selected the correct Paper Weight setting for the media you're using.</p>
	<p data-bbox="511 388 948 441">Be sure the top cover is completely closed and both sides are snapped shut.</p>
	<p data-bbox="511 466 884 487">You may need to replace the fuser.</p>
<p data-bbox="128 508 447 561">Color fades with fuzzy, poorly defined edges.</p> 	<p data-bbox="511 508 953 618">Print out a Menu Setting page and check the level of supplies. If a toner cartridge shows 10% or less, shaking the cartridge may improve the printout.</p>
	<p data-bbox="511 643 953 894">Remove the cartridges and photodevelopers from the printer. Use a lint-free, dry cloth to clean the LED's of any stray toner. Wipe one at a time and proceed from the front of the printer to the back in one gentle swipe. It may take more than one pass. Use a different spot on the cloth or a new cloth for each LED. Reinstall supplies and test.</p>
	<p data-bbox="511 919 953 1260">Remove the supplies from the printer. Check the LEDs are free to move upward. With the supplies out, the metal post is visible on the LED. Push up on the post and make sure it returns to its previous position. If the LED is binding, it is possible there is an incorrect screw holding the cover in place. If too long a screw is installed in the cover it will bind against the LED. The correct screw length is 3.5 mm. Install the screws and test.</p>
<p data-bbox="511 1284 942 1390">Debris in the contact blocks may cause fading. Make sure there is nothing in the contact block to keep it from seating securely when the top cover is closed.</p>	

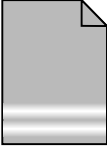
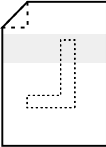
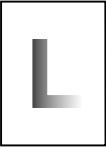
Problem	Action
<p>(continued) Color fades with fuzzy, poorly defined edges.</p> 	<p>Ensure the absorption roll/charge roll on the belt is securely seated. The black plastic T-shaped bushing should both be below the flap on the right side of the belt. A poorly seated roll can cause both skewing of the paper and problems with the magenta print.</p>
	<p>Check that the top cover is firmly closed on the printer. If the cover is not closed completely, the LED may be out of focus and allow light print on the bottom of a letter size page. Close the cover firmly and test.</p>
	<p>Print the quality pages in the Diagnostics Mode (under Print Test, Print Quality Pages). This often identifies the color that has a problem. If you switch the toner cartridges and the problem also changes color on the test pages, the problem is in one of the cartridges. Replace the proper color cartridge.</p>
<p>Toner adheres to the back of the page.</p> 	<p>Remove the fuser oil roll and wipe it with a dry, lint-free cloth, and clean the transfer belt. If there still is a problem, go to “Periodic dirt” on page 2-97.</p>
<p>Quality of printed transparencies is inadequate.</p> 	<p>Be sure you're using the recommended Lexmark transparencies.</p>
	<p>Be sure you have selected the correct paper weight setting for the media you are using.</p>
	<p>When printing transparencies, always set the Paper Type to Transparency.</p>
	<p>Avoid getting fingerprints on transparencies before printing.</p>

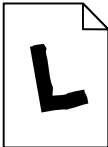
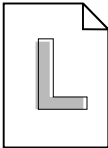
Problem	Action
<p>Print on the page is skewed.</p> 	<p>Be sure the width guides in the paper tray or the multipurpose feeder fit snugly against the media you loaded.</p> <p>Be sure the paper you load fits under the two corner tabs at the front of the tray.</p> <p>Be sure charge roll or belt is seated properly.</p>
<p>A white gap is noticeable between color fills, due to poor color registration.</p> 	<p>Be sure all four corners of the printer are resting on a steady flat surface.</p> <p>Turn the printer off and back on. The printer calibrates the print head timing, which may improve registration. Be sure that Auto Registration, in diagnostic mode, is On.</p>

No image

Possible cause	Action
Moist paper	Be sure the printer is not in a damp environment and the paper is not curled or wavy due to moisture. If necessary inform the customer about correct storage.
LED printhead	Be sure the LED printhead cable is securely connected to the printhead controller board and LED printhead assembly. If the problem remains, replace the LED printhead.
High voltage unit (HVU)	Be sure all the connectors to the high voltage unit are securely connected. If the problem remains, replace the high voltage unit.
Printer controller board	Be sure all connectors are securely connected to the printer controller board. If the problem remains, replace the printer controller board.
Printhead controller board	If the problem remains, replace the printhead controller board.

Black line

Possible cause	Action
Photodeveloper drum	Clean any dirt from the drum surface. Replace it if it is scratched.
<ul style="list-style-type: none"> • Fuser detach pawl • Fuser roller surface • Fuser thermistor surface 	Remove any toner buildup. Replace the fuser.
LED printhead	Clean the LED printhead. Print a blank document. Replace the LED printhead if a black line appears on the paper.

Black print

Possible cause	Action
High voltage unit (HVU)	The printed paper has black print. Be sure the high voltage unit is properly connected. If the problem remains, replace the high voltage unit.
Sub-frame	If the problem remains, replace the right sub-frame contacts.
Photodeveloper drum set	If the problem remains after replacing the sub-frame, be sure the photodeveloper has clean contacts. If necessary, replace the photodeveloper.

Missing colors

Possible cause	Action
<p>Toner cartridge unit</p> <p>Photodeveloper</p>	<p>Be sure the toner cartridge and the PC drum unit are properly seated. Be sure the contacts on the print unit are clean. Be sure the print unit is installed in the correct position. Run a print test.</p> <p>If the problem remains, switch the toner cartridge with another color and run a test print. If the new color prints, replace the failing toner cartridge.</p>
<p>High voltage unit</p>	<p>If the problem remains, check the connector on the high voltage unit. Replace the high voltage unit If the problem remains.</p>
<p>LED printhead unit</p>	<p>If the problem remains, replace the printhead and EPROM.</p>
<p>LED printhead controller board</p>	<p>If the problem remains, replace the printhead controller board.</p>
<p>High voltage unit (HVU)</p>	<p>If the problem remains, replace the high voltage unit.</p>
<p>Transfer belt unit</p>	<p>If the problem remains, replace the transfer belt unit.</p>

Uneven printing

Possible cause	Action
Photodeveloper	Check for condensation or dirt on the photodeveloper.
LED printhead	Clean any dirt off the exposed surface of the LED printhead. Also check the locating pins of the printhead.
Transfer belt unit	Be sure the transfer belt is clean and not damaged. Replace parts as necessary.
Top cover	Be sure the top cover is fully locked.

Periodic dirt

Possible cause	Action
Oil coating fuser roller (OCR)	Check for dirt or damage to the fuser rolls or the oil coating roller (OCR).
Photoconductor drum	Check for scratches on the surface and replace if necessary.
Transfer belt unit	Be sure the transfer belt is clean and not damaged. Replace parts as necessary.

White spots

Possible cause	Action
<ul style="list-style-type: none"> • LED printhead • Photodeveloper • Toner cartridge 	Firmly install the photodeveloper and the toner cartridge into the printer.
Belt unit	Check the transfer belt unit for scratches or nicks. Be sure there is no toner buildup on the belt. Replace the belt unit if it is damaged.

Options service check

Service Tip: When you have a problem with any of the options installed in the options slots on the interconnect board, switch the non operating option to one of the other option slots to isolate the failure.

Serial port

Run the **“Serial Wrap Tests” on page 3-16**.

Note: The Serial Wrap Test is designed to check the serial port hardware by using a wrap plug, P/N 1329048, and invoking the Serial Post Diagnostic Test. The test helps isolate the printer from the serial cable and host computer. The test provides failure information on the display for approximately three seconds. If the test indicates a problem, replace the RIP board.

Flash Memory Option(s)

Run a copy of the test page and check to see if the option you are checking is listed. The printer does not recognize the option being installed if the option is not listed. Be sure the memory card assembly is installed correctly and is not broken or damaged. If the Memory card assembly is correctly installed, not broken or damaged, then run the **“Flash Test” on page 3-25**. If the test fails, replace the Flash card assembly. If the problem continues, replace the RIP board.

DRAM Memory Option(s)

This service check is the same as the flash memory option service check with the following exception:

Run the **“DRAM Memory Test” on page 3-12** from the menu if the DRAM Memory card assembly is correctly installed and not broken or damaged. If the test fails, replace the DRAM card assembly. If the problem continues, replace the RIP board.

Hard Disk Option

Service Tip: The 5055-01 x printers support one hard disk option. Be sure only one 3.2 GB or larger hard disk option is installed. Be sure the hard disk and the hard disk board are correctly installed. Run the **“Quick Disk Test” on page 3-23** from the Device Test on the Diagnostic Menu when a problem is suspected either with the hard disk system board or with the hard disk.

Note: The Quick Disk Test is a non-destructive test and indicates Pass or Fail. If the test fails, replace the hard disk. If a problem still exists, replace the hard disk board.

Use the **“Disk Test/Clean” on page 3-24** to help restore the disk if it contains bad data and is unusable. This test is divided into a cleaning and a verifying or testing section.

Warning: This can be a very lengthy test depending on the disk size. This test leaves the hard disk unformatted. The servicer or user must reformat the disk using the Format Disk Menu operation. This is a destructive type of test. All the data on the disk is destroyed and should not be performed on a known good disk.

Network Card Option

The network is installed on the system board on network model printers.

Error Code 976 - Network Card x (x=Network card 1, 2, or 3)

A 976 error code indicates an unrecoverable software error in network card x. Verify that network card x is correctly installed in the socket on the interconnect board and is properly grounded. If you find no problem, contact your next level of support before replacing the network card.

54 Network <x> Software Error

This error displays when the RIP software detects that a network card is installed in slot x on the interconnect board but cannot establish communications with the network card.

5055-xxx

3. Diagnostic aids

Note: When troubleshooting, or prior to making any adjustment to print quality, always be sure:

- The printer is installed on a level rigid surface.
- The OPCs are never exchanged. Do not exchange a black OPC for a color OPC, as they have different surface phase counts.
- Radar Page is always used when adjusting print registration.

Power-On Self Test sequence

1. Power on.
2. Printer and RIP controller check:
 - ROM and RAM
 - Fuser thermistor
3. Printer hardware check:
 - Paper jam
 - Printer cartridge unit
 - Toner supply
 - Paper cassette present
4. Fuser temperature check. Temperature regulated.
5. Ready:
 - Printer controller
 - RIP controller
 - Printer condition
 - Motor/Fan
 - Heater
6. DC motor drive 1
7. Feeding paper
8. Print
9. Stepper motor drive 2
10. Paper exit
11. Stop

Using the operator panel

The operator panel on your printer has a 2-line by 16-character liquid crystal display (LCD), five buttons, and one indicator light.

The light indicates whether the printer power is on and whether the printer is idle or busy processing a job.

Indicator light

State	Indicates
Off	Printer power is off.
On	Printer is on, but idle.
Flashing	Printer is busy processing a job.

Use the five operator panel buttons to open a menu, scroll through a list of values, select printer settings, and clear error messages.

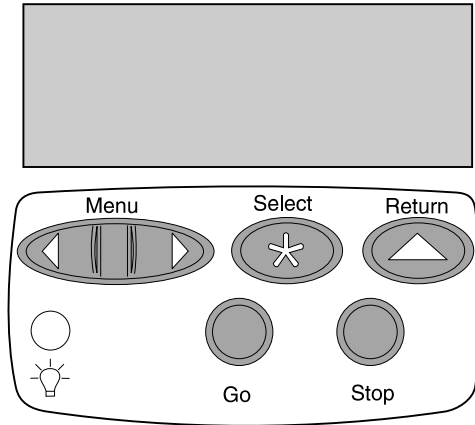

Operator panel buttons

Button	Function
Go	<p>Press Go to:</p> <ul style="list-style-type: none"> • Exit printer menus and return the printer to the ready state. • Clear certain messages from the display. <p>If you've changed printer settings from the operator panel menus, press Go before you send a job to print.</p>
Menu	<p>Press Menu:</p> <ul style="list-style-type: none"> • Enter the menus from the ready state. • Scroll to the next (Menu>) or the previous (<Menu) menu, menu item, or value. • Increase or decrease a numerical value for a menu item setting. • Display the Job Menu or the Supplies Menu while the printer is busy.
Select	<p>Press Select to:</p> <ul style="list-style-type: none"> • Select the menu shown on the second line of the display and view the available menu items. • Select the menu item shown on the second line of the display and view the available values and the current user default setting for that menu item. • Save the value displayed on the second line of the display as the new user default setting. • Clear certain messages from the display.
Return	<p>Press Return to back up to the previous level of the menu structure without selecting a new menu item or value.</p>
Stop	<p>Press Stop when the printer displays the Busy or Waiting message to temporarily stop all activity. The message Not Ready is then displayed until you press Go to continue printer activity.</p> <p>For example, if you need to load paper in a tray while a job is printing, press Stop and wait for the printer motors to idle before removing the tray from the printer. Reinsert the loaded tray, and then press Go.</p>

Printing the menu settings

1. From the printer operator panel, press **Menu** to enter the menus.
2. Continue to press and release **Menu** until you see **TESTS MENU**.
3. Press **Select**. **TESTS MENU** is displayed on the first line, and **Print Menus** is on the second line.
4. Press **Select** again to print the page. The message **Printing Menu Settings** is displayed. The printer returns to **Ready** status after the menu settings page prints.

Operator menu disabled

If the operator has disabled the menu and you want to run operator print tests, turn the machine off, and then press **Go** and **Stop** as you turn the machine on.

Menu overview

<p>SUPPLIES MENU</p> <p>Belt Block Photo Dev Coating Roll Color Photo Dev <color> Toner Fuser Replace Supplies Supplies Life</p>	<p>UTILITIES MENU</p> <p>Color Samples Print Alignment Print Menus Print Net <x> Setup Print Fonts Print Directory Factory Defaults Format Flash Defragment Flash Format Disk Job Acct Stat Hex Trace</p>	<p>COLOR MENU</p> <p>Color Correction Manual Color Print Mode Toner Darkness</p>
<p>PAPER MENU</p> <p>Paper Source PAPER SIZE PAPER TYPE CUSTOM TYPES Configure Bins Assign Type/Bin Substitute Size Configure MP Paper Weight Paper Loading Universal Setup</p>	<p>FINISHING MENU</p> <p>Duplex Duplex Bind Copies Blank Pages Collation Separator Sheets Separator Source Multipage Print Multipage Order Multipage View Multipage Border</p>	<p>USB MENU</p> <p>PCL SmartSwitch PS SmartSwitch MAC Binary PS NPA Mode USB Buffer Job Buffering</p>

<p>JOB MENU</p> <p>Reset Printer Cancel Fax Confidential Job Held Job</p>	<p>SETUP MENU</p> <p>Printer Language Printer Usage Power Saver Resource Save Download Target Print Timeout Auto Continue Wait Timeout Jam Recovery Page Protect Display Language Alarm Control Job Accounting Job Acct Limit</p>	<p>PCL EMUL MENU</p> <p>Font Source Font Name Point Size Pitch Symbol Set Orientation Lines per Page A4 Width Auto CR after LF Auto LF after CR Tray Renumber</p>
<p>POSTSCRIPT MENU</p> <p>Print PS Error Font Priority Image Smoothing</p>	<p>PARALLEL MENU</p> <p>PCL SmartSwitch PS SmartSwitch MAC Binary PS NPA Mode Parallel Buffer Job Buffering Advanced Status Protocol Honor Init Parallel Mode 1 Parallel Mode 2</p>	<p>SERIAL MENU</p> <p>PCL SmartSwitch PS SmartSwitch NPA Mode Serial Buffer Job Buffering RS-232/RS-422 RS-422 Polarity Serial Protocol Robust XON Baud Data Bits Parity Honor DSR</p>
<p>NETWORK MENU</p> <p>PCL SmartSwitch PS SmartSwitch MAC Binary PS NPA Mode Network Buffer Job Buffering Network <x> setup Std Net Setup</p>	<p>INFRARED MENU</p> <p>Infrared Port PCL SmartSwitch PS SmartSwitch NPA Mode Infrared Buffer Job Buffering Window Size Transmit Delay Max Baud Rate</p>	<p>LOCALTALK MENU</p> <p>LocalTalk Port PCL SmartSwitch PS SmartSwitch NPA Mode LocalTalk Buffer Job Buffering NPA Hosts LocalTalk Name LocalTalk Addr LocalTalk Zone</p>

Diagnostic Mode

To access the diagnostics printer settings and operations:

1. Turn off the printer.
2. Press and hold **Go** and **Return**.
3. Turn on the printer. Release the buttons after the **Performing Self Test** message is displayed. The alignment menu displays first.
4. Press **Select** and using the menu key, scroll to **Alignment Test**.
5. Press **Select** to print the test. This prints the three color registration pages. These pages are the same for X, Y, Theta, and for the three colors and are available under the X Adjustment, Y Adjustment, and the Theta Adjustment.
6. There are three adjustments for each color registration; X, Y, and Theta. Adjust X and Y first, and then adjust Theta. X controls the horizontal plane. By adjusting X you move the radar image left (negative) and right (positive). Y controls the vertical plane and by adjusting the value for Y you move the color radar image up (negative) and down (positive). These values are determined by examining the left side of the radar page. Values for X are 1/600th of an inch and Y values are 1/2400th of an inch.
7. Theta controls the skew or angle of rotation. To get the correct reading, adjust X and Y before Theta.
8. Examine the left side radar images for their deviation from black. Look at all the radar images along the left and make a judgment on the value of the adjustment. When the color is correctly adjusted, the color radar image should lay directly on the black radar image.

Setting Printer Alignment

1. Press **Menu** until the color you want to adjust displays and then press **Select**.
2. Change the displayed value and press **Select**. You see a message displayed that the value is Saved. If you want to skip a selection press **Select**.

X= sxxx* Y= sxxx* T= sxx*

3. Press **Menu** until Alignment Test Printing is displayed and press **Select**.

Alignment Test Printing...

4. Look at the color and the value you have changed and see if this is acceptable. If so, go to the next adjustment. If it is not acceptable, go back to the color and adjust it again.
5. When all the values are acceptable for all colors, exit diagnostics.

Note: If **Return** is pressed to exit the Alignment menu after a margin value has been incremented or decremented, then the default value is not changed. However, if the Alignment Test page is requested after a margin value has been incremented or decremented, then the default value is changed and then the Alignment Test page is printed using the new value. The alignment test page should be printed on letter of A4 paper only. To exit the alignment menu, press **Return**.

Adjustment example

Here is a sample of the magenta radar image. Looking down the left side for both X and Y, you can see the X value is close to correct. It may be a little to the right. The Y value for magenta is incorrect. The magenta radar image is too far above the black. In the case of Y, increase the value for Y to move the magenta image down the page. This may not seem intuitive, but increasing the value increases the timing delay, thus moving the image down the page. The images may be off by different amounts. Make the best overall judgement using all the radar images on the left side.

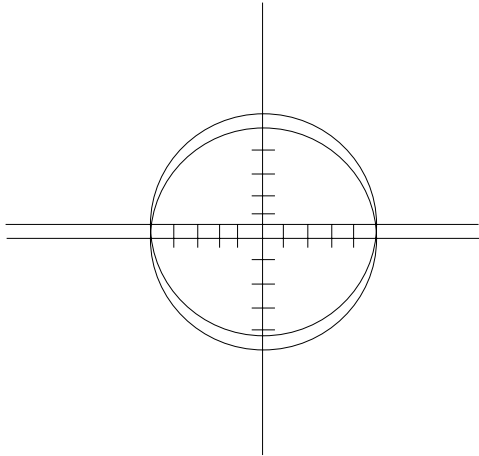

When the Y value is correctly adjusted, the magenta radar image should look like the following example. The Theta adjustment is done in the same manner as the Y except Theta values are taken from the right side of the test pages.

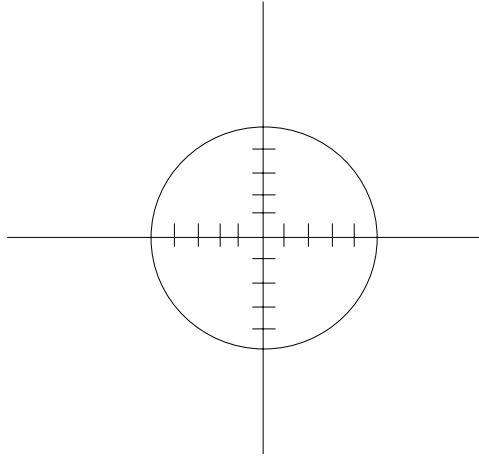

Summary Notes:

Objective: Using the X, Y, and T adjustment procedure, adjust the color to overlay the radar image as precisely as possible.

X and Y values are taken from the left side. Theta is taken from the right.

Increasing values for X drives the color radar right. Increasing values for Y and Theta drive the color radar image down the page.

Do both the X and Y before attempting Theta.

Use a loop or magnifying glass (4x or higher) to make the job easier.

Yellow is very difficult. When you make the yellow adjustment, swap the cyan toner cartridge with the yellow cartridge. Run through the procedure making the correct adjustments to the yellow X, Y, and Theta adjustment. Remember to swap the supplies position back to the correct position when you finish.

Print tests

Input Source Print Tests

The Diagnostic Input Source Print Tests may be used to verify that the printer can print on media from the installed input sources, which are available within the Print Tests menu. Chose from following:

- **Single** (prints the Print Test page once).
- **Continuous** (prints the Print Test page until **Return** or **Stop** is pressed).

The content of the Print Test page varies depending on the media installed in the selected input source. If a source is selected that contains paper, then a page similar to the Quick Test page prints. If a source is selected containing envelopes, the Envelope Print Test pattern prints. This pattern contains text of each character in the selected symbol set.

If **Continuous** is selected, all sources printing with paper sizes print the same page continuously until the test is stopped. If the source contains envelopes, then the envelope print test pattern prints on the first envelope and subsequent envelopes are blank.

Note: The Print Test page can be printed on any paper or envelope size. More than one sheet may be required. The Print Test page always print in simplex.

While the page prints, the following message is displayed: The

A rectangular box with a thin black border containing the text "<source> Printing...". The text is centered within the box.

Power indicator also blinks while the page prints. If **Single** is selected, no buttons are active while the Print Test page prints. If **Continuous** is selected, **Return** or **Stop** can be pressed to cancel the test, producing the following message:

A rectangular box with a thin black border containing the text "Canceling...". The text is centered within the box.

Note: *<input source>* represents the input source selected for the Print Test. One of the following sources is displayed: Tray 1, MP feeder, standard bin (face-down), or Output Bin 1. The value of the *<media width>* field is displayed when the narrow media sensor determines the media used for the Quick Test is narrow or wide, (**N** for narrow, **W** for wide).

Print Quality Pages

Execution of this diagnostic function causes the printer to print the Print Quality Test Pages. Since the printer is in diagnostics mode, the toner cartridge lockout functionality is disabled. Print Quality Pages can be printed from the Configuration Menu Group. When printing using this method, the toner cartridge lockout functionality is enabled. These pages cannot print unless a cartridge with a Machine Class ID matching the Machine Class ID stored in NVRAM is installed.

Note: Additional diagnostic information relating to print quality may be printed on the Print Quality Pages when executing this diagnostic function. This additional information is not printed when the Configuration Menu Group method is used.

As the pages are printed, the printer posts:

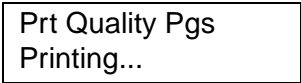

Prt Quality Pgs
Printing...

Once started, this operation cannot be canceled. All keys are ignored while this message is posted.

Note: The *<media width>* field displays once the narrow media sensor determines the media used for the Quick Test is narrow or wide (**N** for narrow, **W** for wide).

Hardware tests

LCD Hardware Test

The LCD Hardware Test causes the printer to continually execute the LCD display test. To cancel the test, press **Return** or **Stop**.

Button Test

The Button Test verifies the operation of each button on the operator panel. When Button Test is selected, the following appears on the display:

```
OP OP OP OP
      OP OP
```

When a button is pressed, CL (Closed) displays. When a button is not pressed, OP (Open) displays. If the wrong message displays, the button is malfunctioning. To exit the button test, press **Return** or **Stop**.

DRAM Memory Test

The DRAM Memory Test checks the validity of DRAM (both standard and optional). Patterns of data are written to DRAM verifying each bit in memory can be set and read correctly. When selecting this test from the operator panel, the printer begins testing DRAM memory and the following message is displayed:

```
DRAM Memory Test
P:##### F:#####
```

Terminology:

P:##### represents the number of times the memory test finishes successfully. Initially 000000 displays for #####. The maximum pass count is 999,999.

F:##### represents the number of times the memory test finishes with errors. Initially 00000 displays for #####. The maximum fail count is 99,999.

The power indicator blinks indicating the memory test is in process. The printer runs this test continually. The test can be terminated by powering off the printer. Each time the test finishes, the screen is updated with the result. If the test is successful, the Pass Count increments by 1. If the test fails, a failure message displays for approximately three seconds and the Fail Count increments by 1. Once the maximum pass count or fail count is reached, the test stops and final test results display.

ROM Memory Test

The ROM Memory Test checks the validity of the RIP code and fonts. When this test is selected from the operator panel, the printer begins testing ROM memory and the following message is displayed.

ROM Memory Test P:##### F:#####

Terminology:

P:##### represents the number of times the memory test finishes successfully. Initially 000000 displays for #####. The maximum pass count is 999,999.

F:##### represents the number of times the memory test finishes with errors. Initially 00000 displays for #####. The maximum fail count is 99,999.

The power indicator blinks indicating the memory test is in process. The printer runs this test continually. The test can be terminated by powering off the printer. Each time the test finishes, the screen is updated with the result. If the test is successful, the Pass Count increments by 1. If the test fails, a failure message displays for approximately three seconds and the Fail Count increments by 1. Once the maximum pass count or fail count is reached, the test stops and final test results appear.

- ROM Checksum Error
- ROM Burst Read Error

Press **Return** or **Stop** to exit the test.

Parallel Wrap Test

The Parallel Wrap Test checks the operation of each parallel signal, using a wrap plug. To perform the wrap test:

1. Disconnect the parallel interface cable, and install the parallel wrap plug.
2. Select **HARDWARE TESTS** from the Diagnostics Menu.
3. Select **Parallel Wrap** to initiate the Parallel Wrap Test.
4. Select the appropriate Parallel Wrap Test (**Parallel Wrap, Parallel 1 Wrap**).

The printer begins testing the parallel hardware and the following message is displayed:

Parallel Wrap
P:##### F:#####

Terminology:

P:##### represents the number of times the memory test finishes successfully. Initially 000000 displays for #####. The maximum pass count is 999,999.

F:##### represents the number of times the memory test finishes with errors. Initially 00000 displays for #####. The maximum fail count is 99,999.

The power indicator blinks indicating the memory test is in process. The printer continually runs the same test until canceled from the operator panel by pressing **Return** or **Stop**. Each time the test finishes, the screen is updated with the result. If the test is successful, the Pass Count increments by 1.

If the test fails, the Fail Count increments by 1 and one of the following failure messages displays for approximately three seconds:

- Sync Busy Error
- Byte Interrupt Request Error
- Strobe Interrupt Request Error
- Init Fall Error
- Init Busy Error
- Init Rise Error
- Host Busy Error
- RAM Data FF Error
- RAM Data AA Error
- RAM Data 00 Error
- RAM Data 55 Error
- DMA Count Error
- DMA Address Error
- DMA Interrupt Error
- DMA Memory Error
- DMA Background Error
- Clear Init Rise Error
- False Init Rise Error
- False Init Fall Error
- Autofeed Rising Interrupt Error
- Clear Autofeed Rise Error
- False Autofeed Rise Error
- Autofeed Falling Interrupt Error
- Clear Autofeed Fall Error.

Once the maximum pass count or fail count is reached, the test stops and the final test results display. Press **Return** or **Stop** to exit the test.

Serial Wrap Tests

The Serial Wrap Test checks each signal of the serial port hardware using a wrap plug. To perform the wrap test:

1. Disconnect the serial interface cable, and install the serial wrap plug.
2. Select **HARDWARE TESTS** from the Diagnostics Menu.
3. Select the appropriate Serial Wrap Test (**Serial Wrap, Serial 1 Wrap**).

The printer begins testing the serial hardware and the following message is displayed:

Serial X Wrap
P:##### F:#####

Terminology:

x indicates which serial port is being tested (blank=standard serial, 1=optional serial port #1).

P:##### represents the number of times the memory test finishes successfully. Initially 000000 displays for #####. The maximum pass count is 999,999.

F:##### represents the number of times the memory test finishes with errors. Initially 00000 displays for #####. The maximum fail count is 99,999.

The power indicator blinks indicating the memory test is in process. The printer runs this test continually. The test can be terminated by powering off the printer.

Each time the test finishes, the screen is updated with the result. If the test is successful, the Pass Count increments by 1. If the test fails, a failure message displays for approximately three seconds and the Fail Count increments by 1.

Once the maximum pass count or fail count is reached, the test stops and final test results display:

Receive Status Interrupt Error
Status Error
Receive Data Interrupt Error
Transmit Data Interrupt Error
Transmit Empty Error
Threshold Error
Receive Data Ready Error
Break Interrupt Error
Framing Error
Parity Error
Overrun Error
Data Error
Data 232 Error
Data 422 Error
FIFO Error
DSR Error
DSR PIO Error
DSR Interrupt Error
CTS Error
CTS PIO Error
CTS Interrupt Error

Press **Return** or **Stop** to exit the test.

High-capacity feeder tests

High-Capacity Paper Feed Test

Test paper feed operation.

1. Turn on the docking safety switch with a non-metallic object.
The interface cable with the printer controller board need not be connected.
2. Close the top cover or manually activate the cover switch.
3. Load paper.
4. Wait until the paper tray stops and the pickup solenoid turns off
5. With the cover closed or with the cover switch activated, press and hold the tray down button for more than 1/2 second.

In steps 1 and 2, paper feeding starts and is continuously fed until the cover is opened. The test ends when the tray motor stops and the paper ejects or the tray down button is released.

Test sequence

1. The tray motor moves the tray to the upper limit.
2. The pickup solenoid activates then de-activates.
3. When the tray down switch is pressed for longer than 1/2 second, the paper feed motor starts, the paper feed clutch operates and feeding begins.
4. Feeding can be stopped by releasing the tray down button.

High-Capacity Paper Feed Sensor / Switch Test

Check the condition of each sensor from the lighting of LEDs on the high-capacity paper feed board. When each sensor operates with the power supplied, the associated LED lights.

To perform the test:

Interrupt the photointerrupter sensor signal or actuate the micro-switch being tested while observing the associated LED on the high-capacity paper feed board.

LED	Sensor Name
1	Paper size sensor 1 switch (letter size 11 inches)
2	Paper size sensor 1 switch (A4 size)
3	Residual paper sensor 1 switch
4	Residual paper sensor 2 switch
5	Residual paper sensor 3 switch
6	Residual paper sensor 4 switch
7	Paper level sensor switch
8	Lower limit switch
9	Cover open sensor switch
10	Docking sensor switch
11	Upper limit switch
12	Paper sensor switch
13	Paper feed sensor switch

Finisher tests

Staple Test

This test verifies the operation of the staple mechanism in the finisher.

The media is fed from the default paper source. After selecting a destination bin, the printer feeds eight pieces of media and accumulates them in the finisher accumulator. The printer prints an alignment pattern during this test. After the last sheet is accumulated, the eight sheets are stapled and fed to bin 2.

The staple test cannot be canceled or terminated once the test has begun. As a result, no buttons are active during the execution of this test.

Hole Punch Test

The media is fed from the default paper source. After selecting a destination bin, the printer feeds eight pieces of media, hole punches them, and feeds them to bin 1. The printer prints an alignment pattern during this test. Go to **“Aligning the finisher and printer” on page 3-80.**

The staple test cannot be canceled or terminated once the test has begun. As a result, no buttons are active during the execution of this test.

Finisher Sensor Test

This test determines whether or not the finisher sensors and switches are working correctly. To run the test, select the Sensor/Sw Test operation from the Finisher Tests top level menu. The following sensors and switches are listed in the bottom level menu:

- Input Path
- Paper Register
- Tray 1 Exit
- Tractor Home Pos.
- Paper Full A
- Paper Detect
- Staple Home Pos.

No Staple
 Punch Box Detect
 Invert Path
 Tray 2 Exit
 Elev. Upper Limit
 Tray Near Full
 Elev. Lower Limit
 Jogging Home Pos.
 Pap. Upper Level
 Fin. Set Switch
 Staple Cart. Set

To select one of the sensors/switches above, press **Menu** until the sensor/switch is displayed. Press **Select**. The following is a sample screen that may be displayed:

Input Path CL

Once the screen is displayed, you can manually actuate each of the sensors or switches. When the sensor is closed, CL is displayed. Likewise, when the sensor is open, OP is displayed. If the wrong message is displayed, then the sensor is malfunctioning.

To exit the sensor test, press **Return** or **Stop**.

- Go into diagnostic mode.
- Finisher tests—Sensor/sw tests
- Input Path—This is the paper exit sensor in the fuser activated by moving the sensor actuator.
- Paper Register—Activate the paper registration sensor and observe the display OP - CL.
- Tray 1 Exit—Activate the tray 1 exit sensor OP - CL.
- Tractor Home Pos.—Activate the tractor home sensor by rotating the green paper clearing knob so that the tractor belt flag actuates the sensor.
- Paper Full A—Activate the paper full A sensor by operating the sensor flag while observing the display.
- Paper Detect—Activate the paper detect sensor by placing a piece of paper into the sensor (photo interrupter)

- Staple Home Position—Activate the staple home position sensor by rotating the geared wheel inside the stapler clockwise. If the sensor is working properly, the display should change from CL to OP at approximately 180° of rotation of the wheel.
- No Staple—Remove the staple cartridge to activate the no staple sensor.
- Punch Box Detect—Remove the punch box and activate the punch box detector sensor level.
- Invert Path—Activate by placing a piece of paper into the sensor (photo interrupter).
- Tray 2 Exit—Remove tray 2 and activate the tray 2 exit sensor.
- Elev. Upper Limit—Activate by pressing the paper full A and the paper upper level together. This causes the elevator motor to operate, allowing the sensor flag to clear the elevator upper limit sensor, thereby activating the sensor.
- Elevator Lower Limit—Activate by inserting a piece of paper into the elevator lower limit sensor (photo interrupter).
- Jogging Home Position—Activate by rotating the jogging motor wheel.
- Pap. Upper Level—Activate by operating the paper upper level sensor flag.
- Fin. Set Switch—Activate by inserting a non-conductive tool into the opening below the staple door.
- Staple Cart. Set—Activate by removing then inserting the staple cartridge.

Device tests

Quick Disk Test

The Quick Disk Test performs a non-destructive read/write on one block per track on the disk. The following message appears while the test is running:

Quick Disk Test
Testing...

The Power indicator blinks while the test is in progress. If the test is successful, the following message is displayed:

Quick Disk Test
Test Passed...

Press **Go**, **Return**, or **Stop** to return to the DEVICE TESTS screen. If the test fails, then the following message is displayed:

Quick Disk Test
Test Failed...

Press **Go**, **Return**, or **Stop** to return to the DEVICE TESTS screen. You cannot cancel this test.

Disk Test/Clean

The Disk Test/Clean Test causes the disk to be formatted, destroying all data on the disk and should not be attempted on a good disk. This test should only be used when the disk contains unusable data.

Note: This can be an extremely lengthy test depending on the disk size, and leaves the disk unformatted.

To run this test, select **Disk Test/Clean** from the DEVICE TESTS menu. The following message appears to warn the customer that all disk contents will be lost:

Files will be
lost Go/Stop?

To continue with the test, press **Go**.

To exit the test immediately and return to the DEVICE TESTS screen, press **Return** or **Stop**. The Power indicator blinks while the test is in progress. Once **Go** is selected, the following screen is displayed to indicate the operation has begun:

Disk Test/Clean
Testing...

If the test is successful, the following message is displayed:

Disk Test Clean
Test Passed

Press **Go**, **Return**, or **Stop** to return to the DEVICE TESTS screen. If the test fails, the following message appears:

Disk Test/Clean
Test Failed

Press **Go**, **Return**, or **Stop** to return to the DEVICE TESTS screen. You cannot cancel this test.

Flash Test

The Flash Test writes and reads data to the flash device, destroying all data, leaving the flash unformatted. The servicer must reformat the flash using the Format Flash menu operation. To run this test, select **Flash Test** from the DEVICE TESTS menu. The following message appears warning the customer that all flash contents will be lost:

Files Will be
Lost Go/Stop?

To continue the test, press **Go**. To exit the test immediately and return to the DEVICE TESTS screen, press **Return** or **Stop**.

The following message is displayed while the test is running:

Flash Test
Testing

The Power indicator blinks while the test is in progress. If the test is successful, the following message appears:

Flash Test
Test Passed

Press **Go**, **Return**, or **Stop** to return to the DEVICE TESTS screen. The Power indicator turns on solid. If the test fails, the following message is displayed:

Flash Test
Test Failed

Press **Go**, **Return**, or **Stop** to return to the DEVICE TESTS screen.

Diagnostics - printer setup

Defaults

The following printer settings are used to determine whether U.S. or non-U.S. factory defaults should be used:

- = U.S. *
- = Non U.S.

Light Quantity

- Cyan
- Magenta
- Yellow
- Black

Range = 0 to 45

If you replace one or more of the printheads, or the EEPROM for the engine controller, the Light Quantity value must be set to the value that is marked on the printhead plus 8. To set this value:

1. Select **Diagnostic Mode**.
2. Select **Printer Setup**.
3. Select **Light Quantity** and enter the value from the label on the printhead, plus 8.

Note: If the printer has S/N XX-1XXXX or above the procedure above **does not** have to be done.

LED Printhead

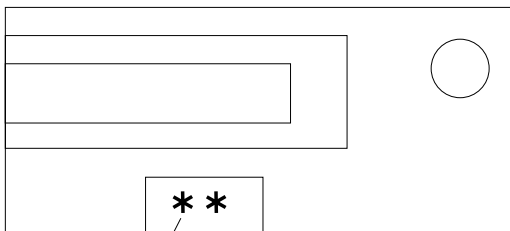

Label

Par S Strobe Adj

This message displays only if the printer is configured with the standard parallel port.

Par 1 Strobe Adj

This message displays only if a parallel port is available through the PCI slot 1.

Par 2 Strobe Adj

This message displays only if a parallel port is available through the PCI slot 2.

Par 3 Strobe Adj

This message displays only if a parallel port is available through PCI slot 3.

Auto Color Adj

- = On *
- = OFF

Reset Calibration

Press **Select** to reset.

Viewing and resetting the drum counters

The drum counters increment when a page is printed. The drum counter for a particular plane increments (if that color is printed), by 1 for Letter, A4, A5, B5 and envelopes, and by 1.2 for Legal and B4. It increments by 2 for 11 x 17, 12 x 18 (C912 only), and A3. The counters are used to track printer usage.

The current value of the drum counter may be viewed in the Diagnostic menus by selecting the **Drum Count** menu, but this value is not viewable from the Ready menu.

The following screen illustrates the operator panel when the cyan drum counter displays. The leftmost digit ('1' in this example) blinks, indicating it is the first digit to be changed. To change the value, press **Menu** until the desired value display. Press **Select** to move to the next digit. The next digit ('2' in this example) blinks. Continue modifying each digit using this method. To skip a digit (and keep its current value), press **Select**.

After the final digit (5 in this example), press **Select** and the new page count is stored in NVRAM.

Cyan Drum Count =12345

The drum counts can be reset by scrolling to the appropriate drum color and pressing **Select**.

Setting the Page Count

The page count can be changed through the Diagnostic menus. The servicer uses this menu to reset the page count whenever the engine board, containing NVRAM memory, is replaced. When **Page Count** is selected from the PRINTER SETUP menu, the current page count is displayed as follows:

Page Count =1234567*

The left-most digit ('1' in this example) blinks, indicating it is the first digit to be changed. To change the value, press **Menu** until the desired value displays. Press **Select** to move to the next digit. The next digit ('2' in this example) blinks. Continue modifying each digit using this method. To skip a digit (and keep its current value), press **Select**. When **Select** is pressed after the final digit ('7' in this example), the new page count is stored in NVRAM.

Viewing the Permanent Page Count

The permanent page count setting cannot be modified through the operator panel. It can only be viewed using the Diagnostics menus. When **Permanent Page Count** is selected, the following appears:

Perm Page Count =1234567*

Serial Number

= XXXXXXXX Printer Serial Number

This function shows the printer serial number.

Setting configuration ID

Use the configuration ID to communicate characteristics of the printer that cannot be determined by the hardware sensors. The configuration ID is originally set when the printer is manufactured, but must be reset whenever the engine board, containing NVRAM memory, is replaced

The configuration ID can be set through the Diagnostic menus. When **Configuration ID** is selected from the PRINTER SETUP menu, the current ID is displayed:

Configuration ID =123456

The left-most digit ('1' in this example) blinks, indicating it is the first digit to be changed. To change the value, press **Menu** until the desired value displays. Press **Select** to move to the next digit. The next digit ('2' in this example) blinks. Continue modifying each digit using this method. To skip a digit (and keep its current value), press **Select**. When **Select** is pressed after the final digit ('6' in this example), the configuration ID is validated. If the ID is invalid, then the Invalid ID displays momentarily on Line 2 before the ID re-displays. If the ID is valid, it is stored in NVRAM and the printer automatically activates the new setting.

If a configuration ID has not been set, then upon entry into diagnostics, the configuration ID setup is the only Diagnostic function displayed until a valid ID is entered.

Diagnostics - error log

Viewing the error log

The Error Log provides a history of printer errors, containing the 12 most recent errors that have occurred. The most recent error displays in position 1, and the oldest error displays in position 12. If fewer than 12 errors have occurred, the oldest error displays in the position before the empty log entries begin. Empty log entries are identified with an error number of 000. Occupied log entries contain the error number for the message displayed on the operator panel. For example, 925 is contained in the log when a 925 service error occurs.

If an error occurs after the log is full, the oldest error in the log is discarded to make room for the new error. The printer stores identical errors in consecutive positions in the log. The following error messages are stored in the error log:

- All 2xx paper jam messages.
- All 9xx service messages

To view the error log, select the **Display Log** operation from the Diagnostics ERROR LOG menu. The entire error log cannot display on a single screen. Four error log entries appear per screen, requiring three screens. To move forward in the log, press **Menu>**, to move backward, press **Menu<**. The following are examples of the error log screens:

1-200	2-290
3-928	4-922

5-250	6-990
7-230	8-230

9-953	10-000
11-000	12-000

To exit the error log, press **Return** or **Stop**.

Clearing the error log

To clear the error log, select **Clear Log** from the ERROR LOG menu. The following message is displayed:

```
Clear Log
= Yes
```

Select **Yes** to clear the log, as the empty log message appears:

```
1-000 2-000
3-000 4-000
```

Select **No**, **Return**, or **Stop** to exit the Clear Log menu.

Maintenance Menu

```
80 Fuser Maint
= 0 to xxxxxxx
```

```
Reset 80 Fuser
=Yes
```

```
80 Belt Maint
= 0 to xxxxxxx
```

```
Reset Belt Maint
=Yes
```

Exiting Diagnostics Mode

To exit diagnostics mode and POR the printer into normal user mode, press **EXIT DIAGNOSTICS**.

Theory of operation

Processes and configuration

In this printer, the toner of four colors (magenta, cyan, yellow and black) melts and deposits dots on paper, which record color image information. This printing process is called the electrophotography process.

Electrophotography process

In the electrophotography process, electrically charged toner exposes, develops, transfers, and is cleaned with an aluminum photosensitive drum. A photoconductive layer forms on the surface of the drum when the drum is exposed to light.

The surface of the photosensitive drum is negatively charged, forming the electrostatic image on the surface of the photosensitive drum. This charge is directed to the photosensitive medium at a low voltage, reducing the generation of ozone to a very low level. When the drum surface is charged, the image is recorded by irradiating light from the LED printhead, forming the electrostatic image. The LED printhead array along with the Selfoc lens array provide a single-dot line of the image, in a one-to-one arrangement. The image data from the printhead controller causes the LED to emit light in black dots. These black dots form an image of dots on the photosensitive drum.

The LED printhead minimizes the displacement of images during the color print process, when images of multiple printheads overlap, causing dot position accuracy to be much higher. Since light from the volume of the LED array varies depending on the LED printheads, the light emitting value is recorded in the EPROM of the printer controller. When the LED printhead is replaced, the light emitting value should be entered for each printhead while the printer is in maintenance mode.

Since the LED printhead and EPROM on the printhead controller board of this printer are paired, the EPROM on the printhead controller board should also be replaced whenever the printhead is replaced.

Development unit

Toner forms the electrostatic image on the photosensitive drum during exposure. The single component, non-magnetic toner and the lusterless color toner are weather-resistant, and fade little under ultraviolet rays. This is helpful in saving documents.

Toner in the hopper is agitated and supplied to the development roll by the supply roll. A (conductive rubber) doctor blade is fitted to the development roll. Toner enters between the development roll and doctor blade by the rotating development roll and is negatively charged, forming the electrostatic image on the photosensitive drum. Toner attaches to the bright portion of the photosensitive drum per the voltage of the development roll.

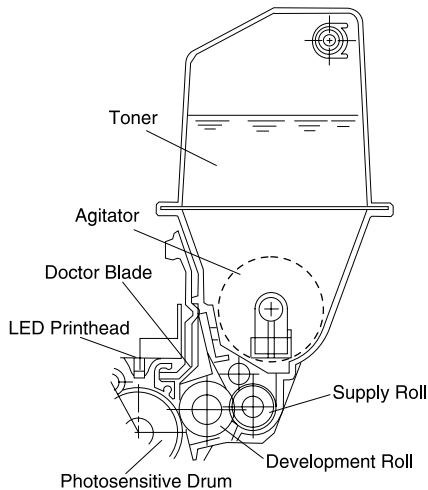

Transfer unit

Paper feeds electrostatically by the transfer belt and is carried to the transfer unit which turn at the speed of the photodeveloper drum. A charge roller applies a positive charge to the paper. The toner image formed on the photoconductor drum is transferred to the paper from the back side by the positive dc voltage applied to the transfer sheet, which is in contact with the paper through the transfer belt.

Cleaning unit

Toner remaining on the photosensitive drum following transfer, is scraped away with the cleaning blade, and collected in the recovery bag as waste toner. Residual toner on the photosensitive medium is removed by the eraser.

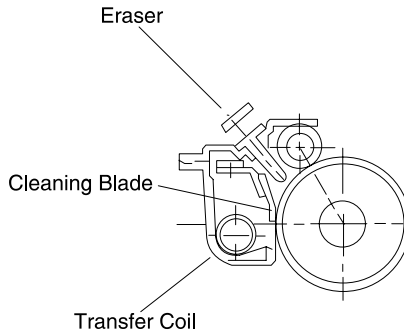

Paper feeding / fusing

The main unit drive is composed of drives 1 and 2. Drive 1 feeds paper, stands by, drives the belt unit, separates, fuses, feeds the face up delivery unit, and drives the photodevelopers and toner cartridge by rotations of the dc motor. Drive 2 drives the face down delivery unit by rotations of the stepper motor.

The expansion paper feeder and the duplex unit use independent motors to drive the paper delivery unit.

Drive system

Drive 1, composed of a 100 V dc motor and gear unit, feeds the registration paper from the paper feeder and drives the belt unit, photodevelopers / toner cartridge, fusing unit, and face-up delivery unit. The motor rotates by the ON signal from the printer controller/motor drive unit and sends a rotation synchronization detection signal to the motor drive unit.

Note: The gear unit of drive 1 is adjusted in phase and should not be disassembled.

Drive 2, composed of a hybrid stepping motor and gear unit, drives the face-down delivery unit.

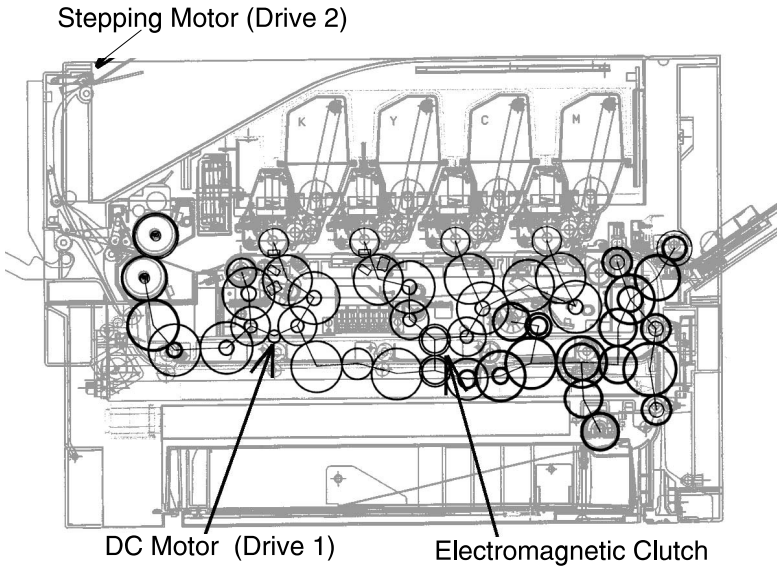

Paper feeding

The paper feeder is a two-way system composed of the multi-paper feeder (100 sheets maximum) and an integrated 550-sheet tray. Optionally, the expansion paper feeders (550 sheets) can be increased to four layers. A high-capacity paper feeding system (3,000 sheets) may be used. Combining the multi-paper feeder, expansion paper feeders, and high-capacity paper feeding system gives the printer a maximum paper supply of up to 5,850 sheets.

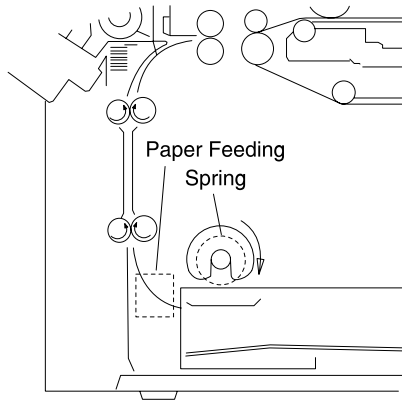

Cassette paper feeder

The paper feeding solenoid turns on by the signal from the printer controller. The paper feeding roller interconnected with drive 1, rotates with the spring clutch and picks the paper in the paper cassette.

Multipurpose feeding

The multipaper feed solenoid turns on by the signal from the printer controller. The multipurpose feed roll interconnected with the drive 1 through the spring clutch, rotates and picks the paper in the multipurpose feeder.

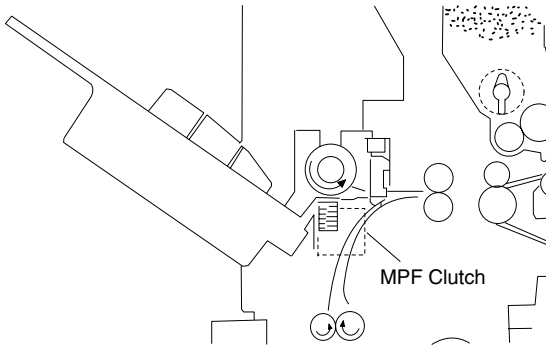

Registration unit

Media temporarily stops (registration) when adjusting the paper leading edge parallel with that of the image, or when adjusting the timing with the black image.

The upper and lower registration rolls are arranged in parallel with the photosensitive drum for black imaging. The lower registration roll incorporates a registration clutch which feeds or stops the paper.

In the forward direction of the registration roll, a registration sensor (photo interrupter) is provided to detect paper fed from the paper feeder and to stop paper jam feeding.

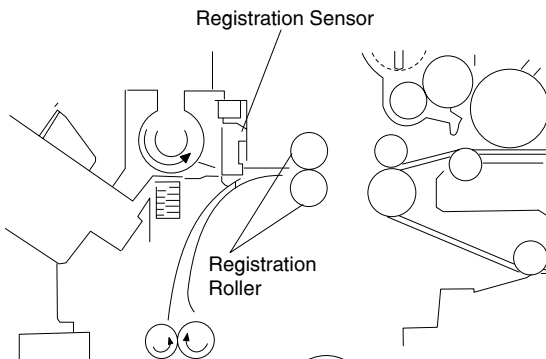

Separation unit

The transfer belt and paper are separated with the belt drive roll by separation fingers.

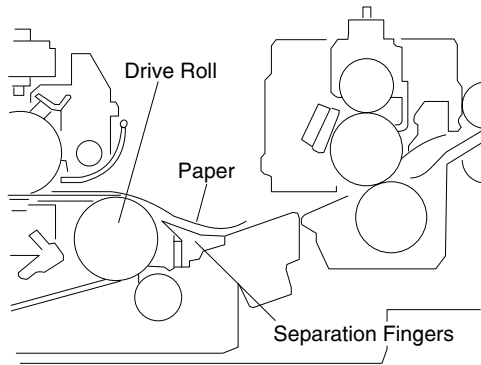

Fuser unit

By applying heat and pressure, the image is melted and fused to the paper.

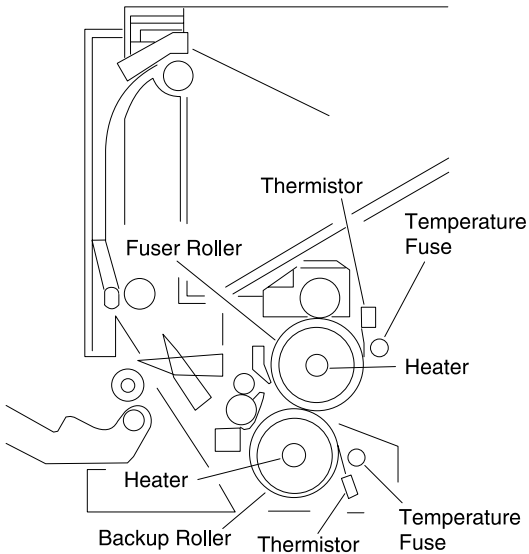

The upper and lower rollers are heated and pressure-fitted. A heater is positioned in the roller tube and a thermistor and thermostat remain in contact with the outside of the tube. Separation fingers are attached near the upper roller to separate the paper from the roller.

Each thermistor sends the surface temperature of the roller to the printer controller. The printer controller turns the heater on or off according to the voltage of each thermistor. If the controller fails and the temperature of the roller exceeds specifications, the temperature fuse (TCO) connected to each heater opens, preventing overheating.

Delivery

After completing the fusing process, paper is discharged from the printer. The delivery sensor detects the paper condition and the FU/FD deflector switches between the face-up and face-down paper delivery. The paper from the fuser pulls down the sensing lever turning on the delivery sensor (photo interrupter). If the delivery unit remains on longer than specified, the printer controller determines that the printer is jammed, and the paper delivery flap lever switches to either face down or face up.

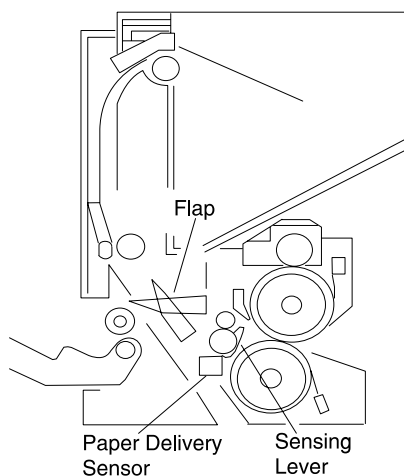

Belt unit

After passing through the registration unit, paper is electrostatically fed by the transfer belt through the positively charged feed roll at the inlet of the belt unit and fed by the running belt. The belt runs at the same speed as the photosensitive drum causing the image on the C, M, Y and K developer to transfer to paper.

Since the photosensitive drum has a small diameter and the paper is electrostatically fed by the transfer belt, the paper is easily separated, after toner image transfer, and fed to the next developer. Excess toner is scraped from the drum with a cleaning blade and recovered into the waste toner bottle.

Adjust the registration when the belt unit is replaced. The registration is adjusted at the leading edge of the image or by adjusting the color image. This should be adjusted in maintenance mode, when the belt unit is replaced.

The transfer belt is conductive and seamless. If the transfer belt is damaged, toner can cling to the belt and contaminate the paper. When fingerprints or other stains appear on the belt, wipe them away with a dry cloth or cloth moistened with alcohol.

A density sensor is positioned facing the belt drive roller for automatic density adjustment and registration adjustment. A mechanism is provided to clean the sensor surface, which is interconnected with the opening and closing of the front cover.

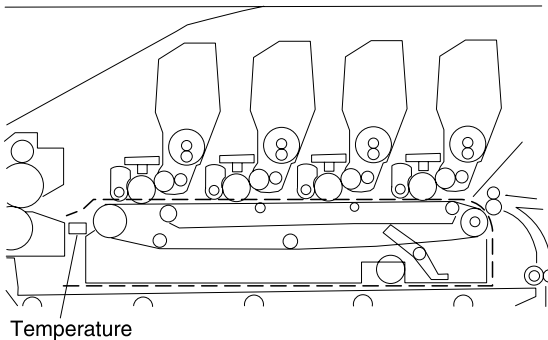

Belt up/down

In monochrome printing, switching to color printing is not required. To avoid unnecessary wear of the photosensitive drum by the cleaning blade, this operation is stopped with the electromagnetic clutch in drive 1. The transfer belt is lowered so as not to touch the photosensitive drum during color printing.

The transfer belt moves up and down with the switching shaft cam by the electromagnetic clutch in drive 1. The belt position is used to detect the cam position with the photo sensor, using the fan shaped light blocking plate attached to the switching shaft. Printing with the transfer belt lowered is called monochrome mode and color printing is called color mode.

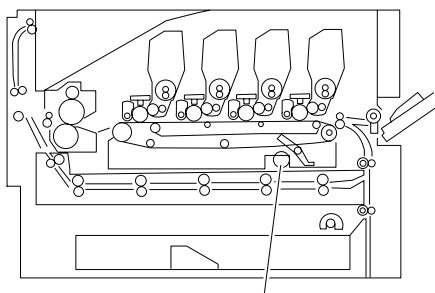

Electromagnetic Clutch (BUD)

Expansion paper feeder

The optional expansion paper feeder can be installed at the lower part of the main unit. Including the main unit, up to five layers of cassettes can be used for cassette paper feeding.

Duplex unit

A duplex unit can be optionally installed in the main unit, allowing two-sided printing.

Selecting Paper feeding, Registration, Transfer, Separation, Fusing, or Face-Down paper discharging with the pulse motor in the duplex unit, feeding is stopped before the paper is delivered. Paper delivery is then reversed and fed to the duplex unit.

Paper fed with the duplex unit stops once, and the center position is corrected by the operation of the side guide plate. Paper is then re-fed by the printer controller signal to the main unit, and, following printing on the back side, is delivered to the normal feeding path.

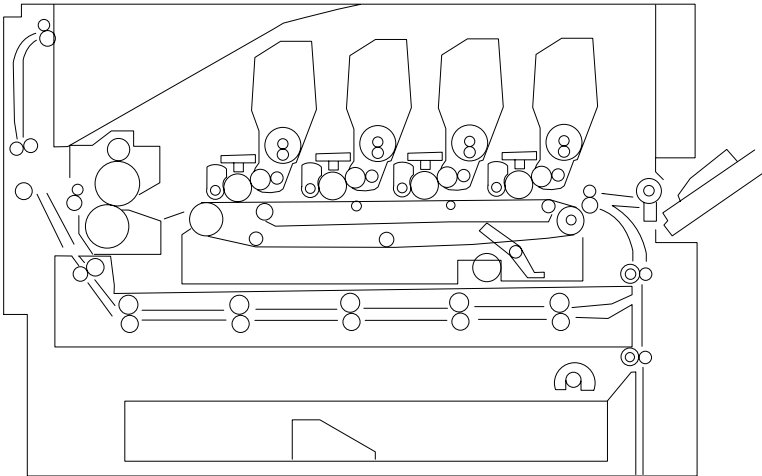

When non-offset type color toner is used, the process speed in the OHP mode is decreased, causing toner to melt sufficiently with the fusing unit, while the fusing temperature is set higher than usual to increase the smoothness on the surface of the toner image.

This mode restricts paper feeding to multipaper feeding, not cassette feeding.

Paper weight

Purpose:

To identify the relative weight of the paper loaded in a specific source and ensure that the toner adheres properly to the printed page.

Values:

Plain weight	Preprint weight	Bond weight	Labels weight
Card stock weight	Colored weight	Envelope weight	Letterhead weight
Transparency weight	Custom <x> weight	Glossy	

Light 16-20 lb

Normal* 20-24 lb

Heavy 24-28 lb

Clearing paper jams

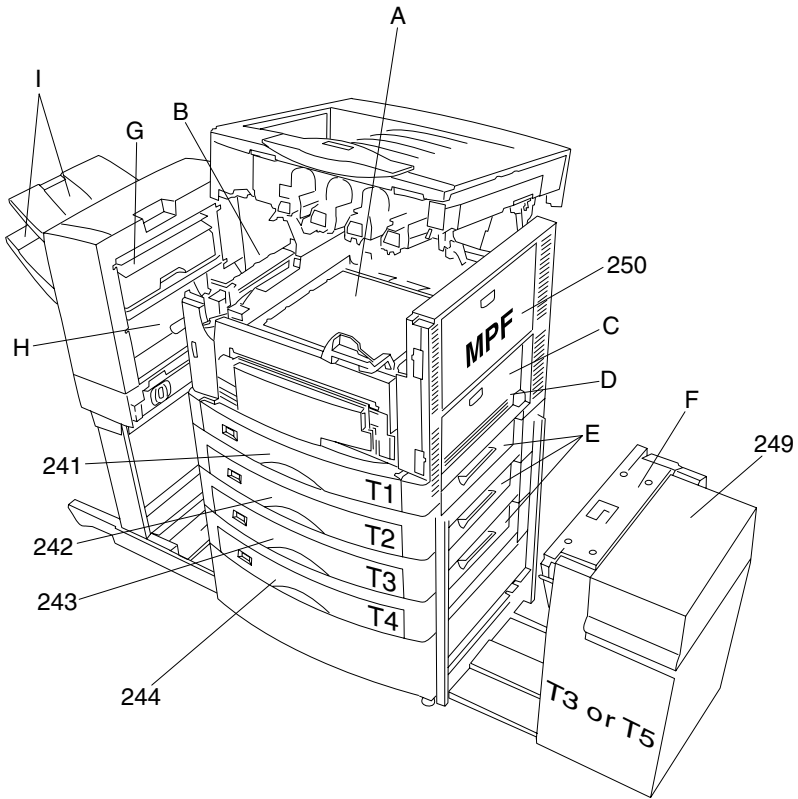

200 Paper Jam

This message identifies the areas (**A–F**, **MPF**, or **T1–T5**) you need to check to remove the paper or to clear the message.

Check Areas A, B

This message indicates a paper jam in the transfer belt, fuser, or output roller area. To clear areas A–B:

1. Open the front door.
2. Rotate the top cover locking lever to the left.
3. Place both hands on the lifting points and squeeze the right top cover latch.

4. Lift the cover.

Warning: Do not use pointed objects to remove the paper. They may damage the transfer belt.

Note: The paper may be covered with unfused toner, which can stain garments.

5. Remove any paper on the transfer belt.

If the paper source was the multipurpose feeder, check the area between the multipurpose feeder and the transfer belt.

6. Check the fuser area and top cover for additional jams.

If there is no jammed paper in the fuser area or top cover, go to step 12. If jammed paper is present, continue with step 7.

7. Lift the fuser pressure release lever.
8. Slowly pull the paper out toward the inside of the printer.
9. Rotate the fuser pressure release lever down.

Note: The top cover will not close until the lever is in the down position.

10. Check the top cover for additional jams.

If none, go to step 12.

11. Remove the jam.
12. Place both hands on the top cover.
13. Press down firmly until the top cover *clicks* into place.
14. Rotate the top cover locking lever to the right.

If you cannot rotate the locking lever, the cover is not fully closed.

15. Open the jam access door on the left side of the printer.
16. Remove any paper inside the printer.
17. Close the jam access door.

To prevent additional paper jams, make sure both sides of the door are closed.

18. Close the front door.

19. Press **Go**.

If the paper jam message continues, check and clear all paper from the paper path.

Check Area C

This message indicates a paper jam in the duplex unit area by the access door. To clear area C:

1. Open the duplex jam access door on the right side of the printer.
2. Remove the jam.
3. Press **Go**.

If the paper jam message continues, clear any paper from the paper path.

Check Area D

This message indicates a paper jam in the duplex unit area. To clear area D:

1. Open the duplex jam access door on the right side of the printer.
2. Gently pull out the duplex unit.
3. Turn the paper forwarding dial counterclockwise.

If the paper advances, remove the jam and go to step 7. If it does not advance, go to step 4.

4. Open the duplex unit covers.
5. Remove the jam.
6. Close the duplex unit covers.
7. Push in the duplex unit.
8. Close the duplex jam access door.
9. Press **Go**.

If the paper jam message continues, clear any paper from the paper path.

Check Area E

This message indicates a paper jam in the top, middle, or bottom optional drawer paper path area. To clear area E:

Note: If you have a high capacity feeder, pull it away from the printer.

1. Open the jam access door on the top optional drawer.
2. Remove the jam.
3. Close the jam access door.
4. Open the jam access door on the middle drawer.
5. Remove the jam.
6. Close the door.
7. Open the jam access door on the bottom drawer.
8. Remove the jam.
9. Close the door.
10. Press **Go**.

If the paper jam message continues, clear any paper from the paper path.

Check Area F

1. Pull the high capacity feeder away from the printer.
2. Open the jam access door on the top optional drawer.
3. Remove any jam.
4. Close the jam access door.
5. Slide the high capacity feeder until it locks to the docking frame.

When the feeder is in the correct position, you hear a *click*.

6. Press **Go**.

If the paper jam message continues, check and clear all paper from the paper path.

240 Paper Jam

1. Slowly pull the jam out of the multipurpose feeder.

Note: If you are feeding banner paper, do not pull the paper out; instead, begin with step 2.

If the paper will not come out, proceed with step 2. If it does, go to step 10.

2. Open the front door.
3. Rotate the top cover locking lever to the left.
4. Place both hands on the lifting points and squeeze the right top cover latch.
5. Lift the cover.

Warning: Do not use pointed objects to remove the paper. They may damage the transfer belt.

6. Remove the paper on the transfer belt.
7. Place both hands on the top cover.
8. Press down firmly until the top cover *clicks*.
9. Rotate the top cover locking lever to the right.

If you cannot rotate the locking lever, the cover is not fully closed.

10. Close the front door.
11. Press **Go**.

241–244 Paper Jam

Note: Although tray 1 is shown, you can use the same procedure to clear any of the **241–244 or Check Tray 1–4** messages.

Paper jam messages **241–244** and **Check Tray 1–4** indicate a jam in one of the paper trays. To remove the jam:

1. If you have a high capacity feeder, pull it away from the printer.
2. Open the jam access door for the paper tray indicated on the display.
3. Remove the jam.
4. Close the jam access door.
5. Pull out the paper tray indicated on the display.
6. Remove any damaged paper.
7. Push down on the remaining paper in the tray until the bottom plate *clicks*.
8. Close the paper tray.
9. Press **Go**.

If the paper jam message continues, clear any paper from the paper path.

249 Paper Jam

Note: If you have an optional printer cabinet, the high capacity feeder will be identified as tray 3.

A **249 Paper Jam Check Tray 5** message indicates a jam in the high capacity feeder. To remove the jam:

1. Open the high capacity feeder top cover.
2. Remove the jam.
3. Close the cover.
4. Press **Go**.

High-capacity feeder (HCF)

Paper feed and separation mechanism

The high-capacity feeder consists of a tray and paper transfer mechanisms. The paper feed and separation mechanism uses a friction roller separation and paper feed system with a non-contact magnet type maintenance-free torque limiter.

When the paper feed clutch turns on, the paper feed roller shaft rotates and the paper feed roller is driven with the one-way clutch. The call roller rotates with the relay gears to feed the top paper. The reverse roller rotates along with the paper feed roller.

During paper feed, if two sheets feed, the reverse roller rotates by the torque limiter, returning the lower sheet. When the paper feed sensor (reflection type sensor) detects the paper, the pickup solenoid turns off to raise the call roller, transferring the paper to the registration roller.

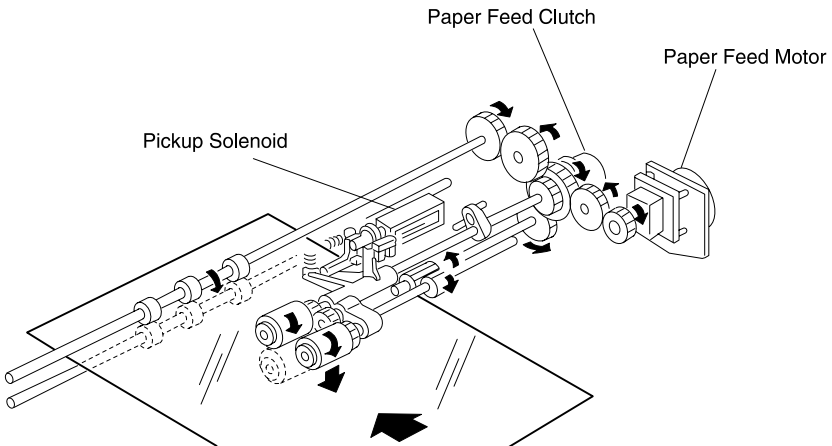

Registration operation

When the paper feed motor rotates, the transfer roller is driven with relay gears. The reverse roller shaft rotates the gears on the paper feed clutch in the direction of the arrow and stops by the friction force of the paper feed roller.

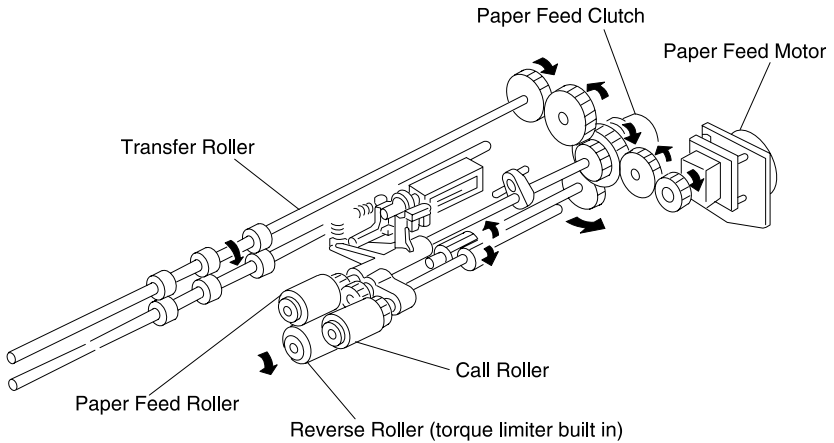

Tray up/down mechanism

The driving force of the tray motor transmits to the tray driving pulley through the gears. Moving the tray moves up and down through the tray driving belt. After the paper loads, and the top cover is set, the pickup solenoid turns on to lower the call roller. When the tray moves up, the call roller is raised by the top surface of the paper, and the shield plate on the up sensor is released from the up sensor which turns off the tray motor.

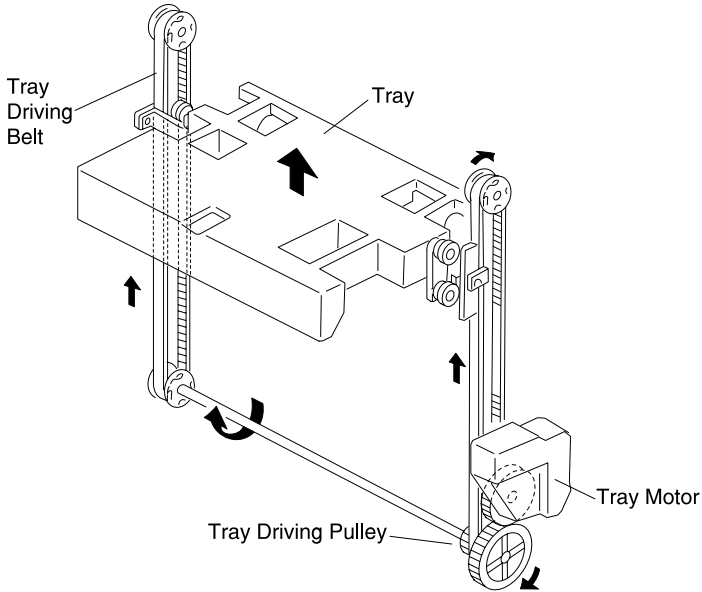

Also, when the top surface of the paper lowers during printing and the up sensor is shielded, the tray motor again rotates forward to raise the paper.

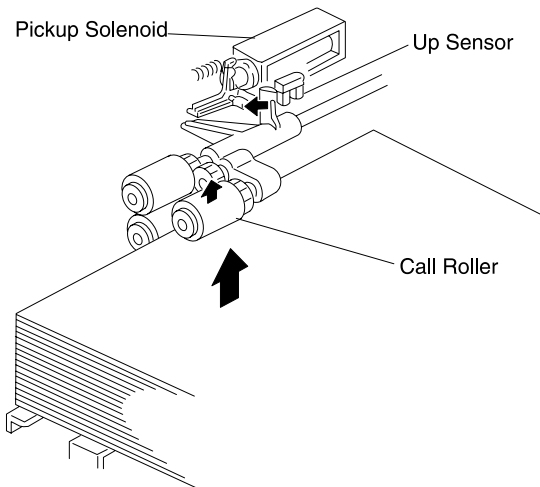

When the down button is pressed, the tray motor reverses to move the tray down. During the down motion of the tray, as the top surface of paper passes the paper level sensor, the tray motor stops. The

tray moves down by about 500 sheets. The down sensor detects the tray lower limit position.

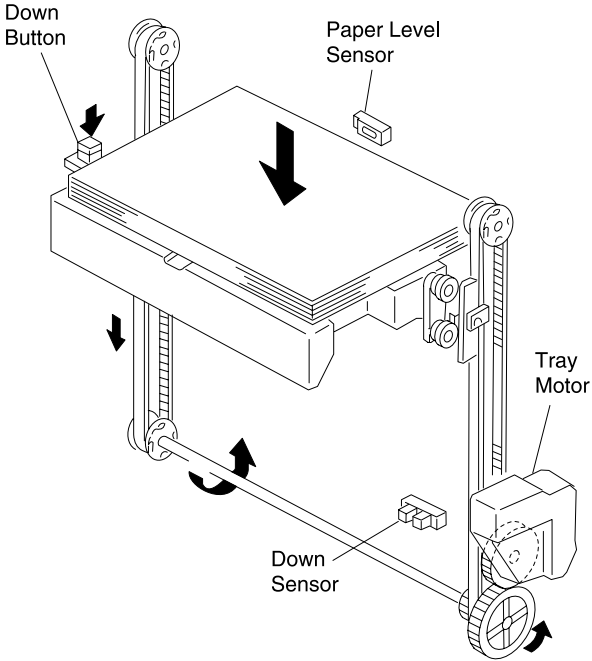

Tray up condition

Tray up motion stops when the:

- Up sensor is OFF (not shielded)
- Power cord is connected and the joint switch is ON
- Up sensor is ON (shielded) during printing
- Top cover is closed, or when up sensor is ON

Tray down condition

Tray down motion stops when the:

- Paper level sensor is OFF
- Down button is pressed
- Paper end is detected

Size detection mechanism

The paper size can be switched between A4 and letter (11 inches) by changing the side fence position.

The paper size sensor 2 detects the fixing screw 2 at the A4 position.

The paper size sensor 1 detects the fixing screw 1 at the letter position. Tray up motion stops when the up sensor is OFF, not shielded.

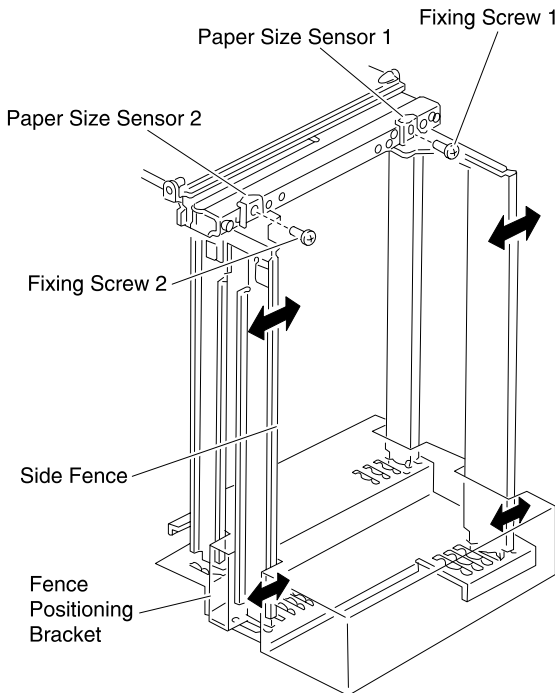

Residual paper detection mechanism

The residual paper quantity in the tray is detected with four photo interrupters. The quantity of pages remaining in the sheet feeder displays in the following increments:

- Near end, about 80 sheets
- About 300 sheets
- About 1,000 sheets
- About 2,000 sheets

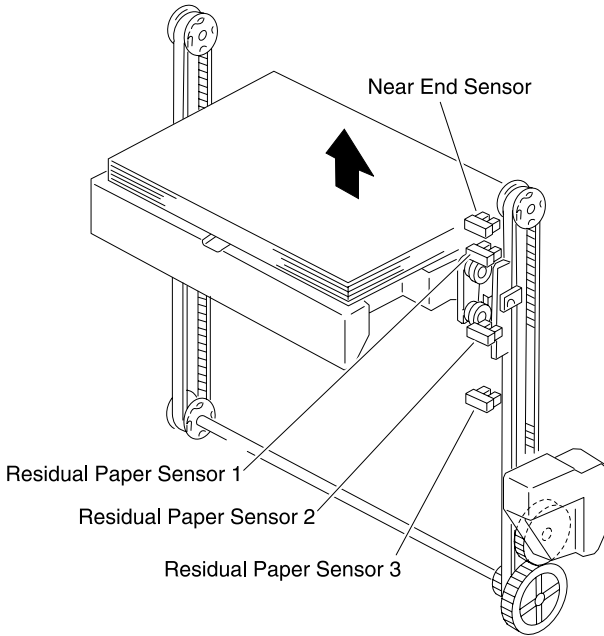

Paper end detection

A reflection type sensor is provided on the top stay to detect the paper top surface and the paper end.

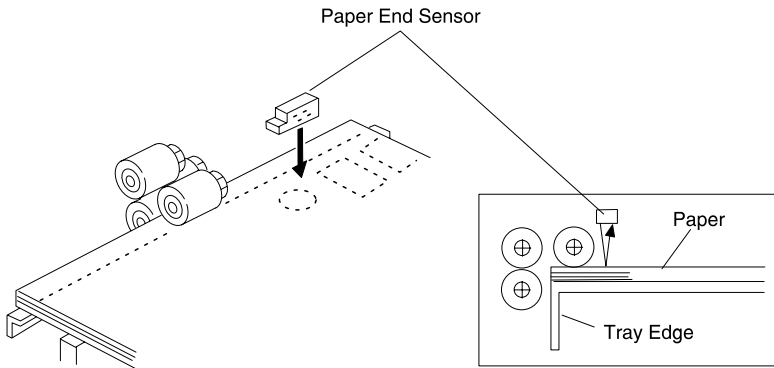

Maintenance Mode

DIP switch specifications

The DIP switches on the high-capacity paper feed board have the following functions:

- Function switching and initial setting of the standard machine or optional machine.

DIP switch	Function switch		Maintenance switch		Description
	4	3	2	1	
OFF					1 Standard machine initial setting
ON	X	X			
OFF	X				2 Optional machine initial setting
ON		X			

- Maintenance switch (test mode selection) is valid without connecting to the printer controller board.

DIP switch	Function switch		Maintenance switch		Test paper feed mode (standalone)
	4	3	2	1	
OFF					Test OFF mode
ON			X	X	
OFF			X		Linear velocity 101 mm/s Thick paper mode
ON				X	
OFF			X	X	Linear velocity 129 mm/s Plain paper mode
ON					
OFF				X	Linear velocity 180 mm/s
ON			X		

Finisher

The finisher communicates with the host engine through serial interface signals and performs the following operating modes:

- **Straight**—exits paper to the upper tray.
- **Punch and straight**—stops paper at the leading edge, punches it, and exits it to the upper tray.
- **Invert**—sends paper to the accumulator, and exits it to the lower tray.
- **Punch and invert**—stops paper at the leading edge, punches it, and sends it to the accumulator where it exits to the lower tray.
- **Invert and staple**—jogs each sheet of paper in the accumulator. When the accumulated number of sheets reaches a designated number, it staples a batch of sheets, and then exits the stapled set to the lower tray.
- **Punch, invert and staple**—stops paper at the leading edge, punches it, sends it to the accumulator and jogs each sheet. When the accumulated number of sheets reaches a designated number, the batch is stapled, and exited to the lower tray.
- **Invert and offset**—jogs each paper in the accumulator, shifts it by the offset, then exits it to the lower tray.
- **Punch, invert and offset**—stops paper at the leading edge, punches it, sends it to accumulator and jogs each page, offsets it, and then exits it to the lower tray.

Note: Capacity is up to 100 sheets of 20 lb paper in tray 1 (top tray) up to 1000 sheets of 20 lb paper in tray 2 (lower tray).

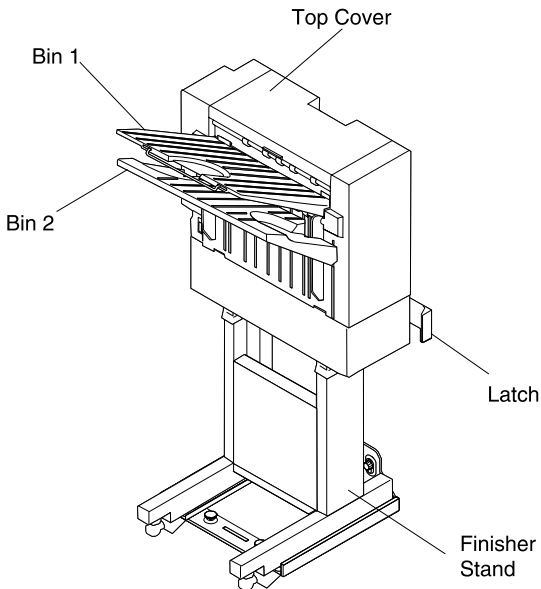
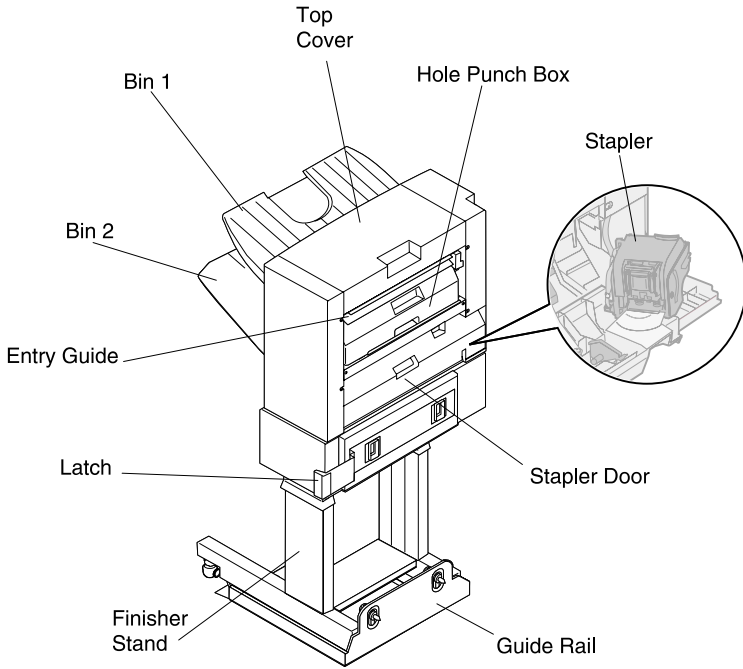

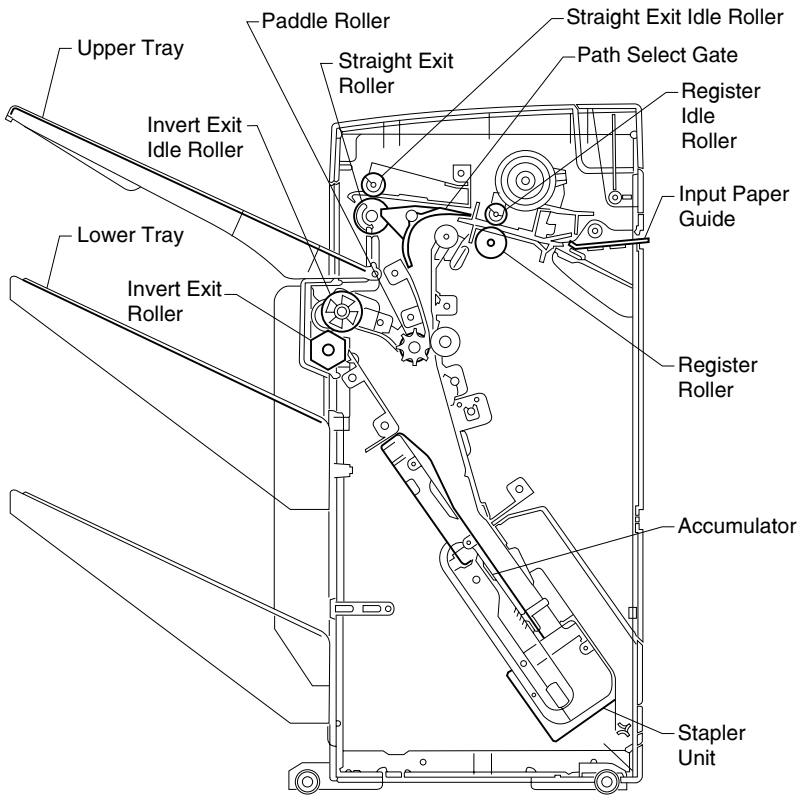
Finisher cross section

Electrical parts function

- **Finisher Set Switch**—detects the connection with the printer.
- **Staple Cartridge Set Switch**—detects when the staple cartridge is open.
- **Staple Existence Sensor**—detects when the stapler is empty.
- **Staple Home Position Sensor**—locates home position for stapling.
- **Paper Register Sensor**—detects when paper enters into the finisher, detects paper jams and triggers the punch.
- **Paper Exit Sensor (Upper Tray) (Letter), Invert Path Sensor (A4)**—detects when paper feeds into the lower tray, the end of jogged paper and paper jams.
- **Paper Exit Sensor**—detects that paper has exited the printer.
- **Tractor Home Position Sensor**—locates home position for the drive belt.
- **Elevator Upper Limit Sensor**—detects when the lower tray is at the highest position.
- **Jogging Home Position Sensor**—locates home position for the jogging bar.
- **Paper Detecting Sensor**—detects when the paper is at the correct position for stapling.
- **Paper Full Sensor A**—detects when there is a full stack of paper on the lower tray.
- **Paper Upper Level Sensor B**—Locates the top of the stacked paper on lower tray. Also detects when paper is removed from stacked papers on the lower tray while stacking.
- **Elevator Lower Limit Sensor**—detects when the lower tray is at the lowest position.

Paper feed mechanism

Paper is transported, after it is detected at paper register sensor by drive gears and drive belts, driven by the paper feed motor or tractor drive motor and other rollers. Paper path route differs subject to the selected mode.

Straight paper path (exit paper to upper tray)

Paper feed motor drives and rotates rollers. The path select gate is changed by the path select solenoid, and paper goes out to the upper tray by the exit rollers.

1. Path select gate solenoid
2. Solenoid

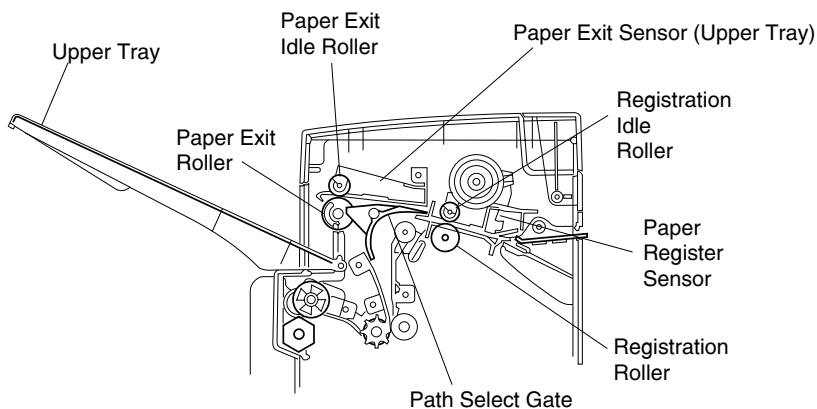

5055-xxx

Path select gate

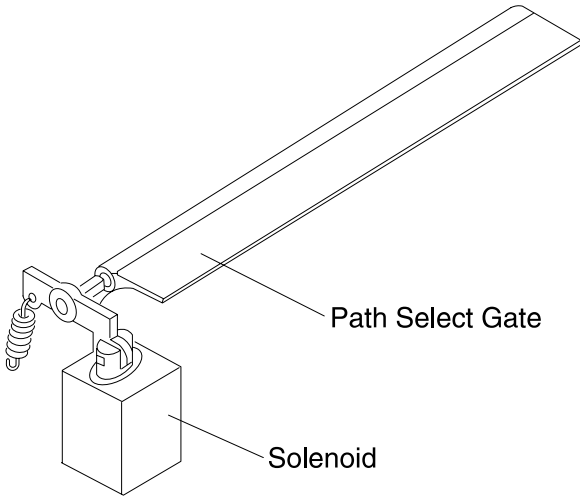

Inverting paper path (exit paper to lower tray through accumulator)

The paper feed motor drives and rotates the rollers as paper feeds through the registration rollers, path select gate, and patting rollers. Paper is detected by the invert path sensor. Paper is then jogged by jogging bar and driven by the belt drive motor before exiting to the lower tray (accumulator).

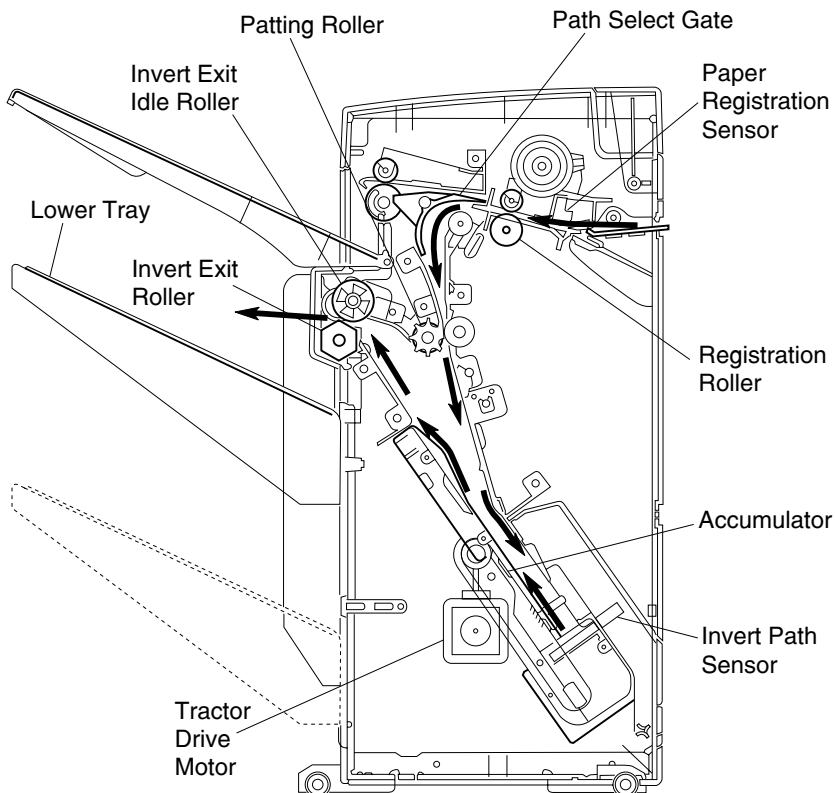

Accumulator

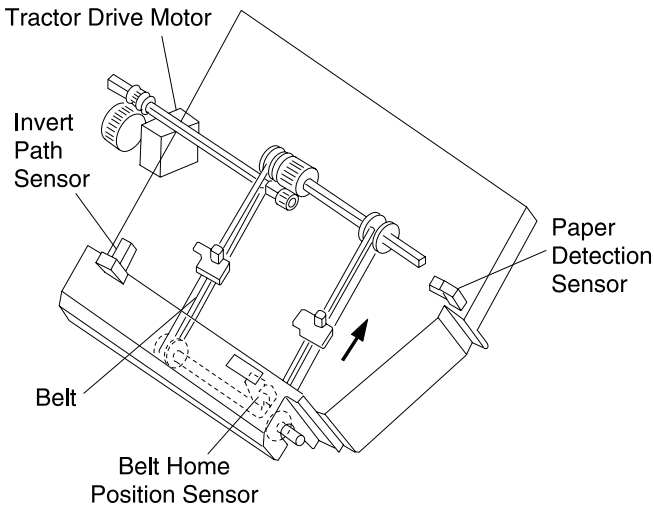

Paper registration sequence

Paper is stopped at the hole punching position momentarily before the paper standstill clutch turns ON and changes to open. At this point the driving force cannot be transmitted to the register rollers. The paper then stops at register rollers, and since the finisher keeps feeding the paper from the host printer, the leading edge of the paper stops at the register rollers. The paper buckles at the entrance. The paper buckle feeds downward to the lower entrance paper guide, where it is hole-punched at the leading edge. The paper standstill clutch turns OFF and changes to close as the driving force transmits to register rollers and the paper transportation restarts.

Punch unit driving sequence

When the paper feed motor drives, the driving force is transmitted through the punch unit drive gear to the clutch gears of the punch unit. Since the punch clutch is normally opened OFF, the driving force is not transmitted to the driving shaft. When the punch clutch turns ON, it is closed and unlocked. The driving force is then transmitted from the clutch gears to the driving shaft. As the shaft turns, the rotation of the cam causes the paper to be hole-punched. Immediately after one turn of the shaft, the punch clutch turns OFF, and the drive shaft stops.

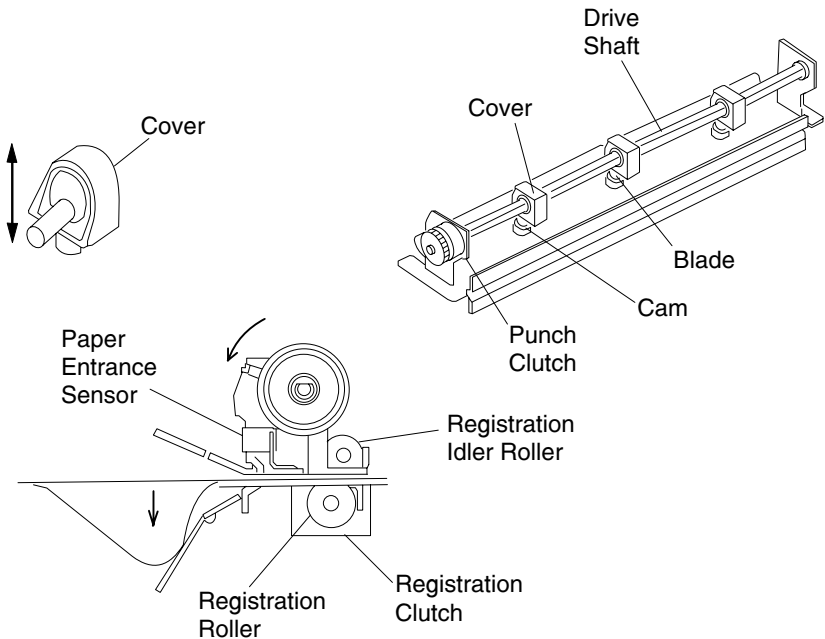

Jogging / offset mechanism

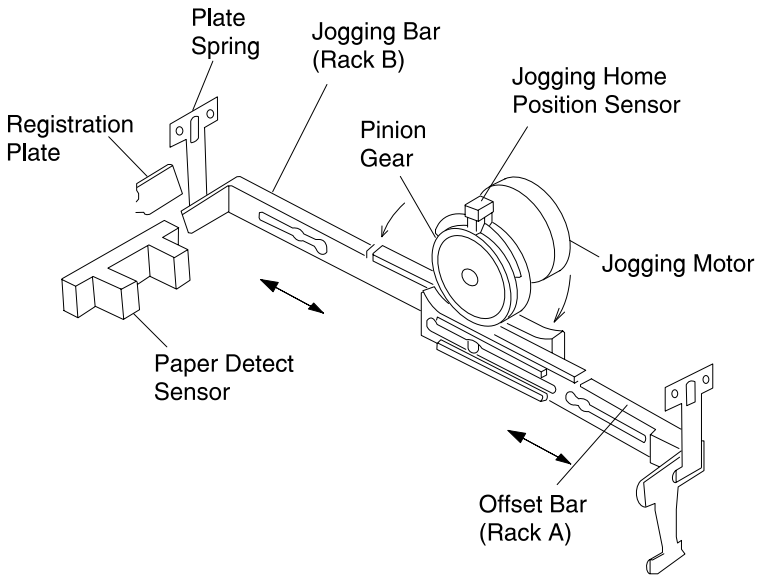

Jogging sequence

Each sheet, upon entering the accumulator, is aligned by the jogging bar which moves the sheet horizontally until the edge of the sheet contacts the registration plate. The paper detecting sensor detects the paper position for stapling.

Offsetting sequence

Sheets of jogged paper are offset by the horizontal movement of the jogging bar. The jogging bar, is moved horizontally by the rack and pinion mechanism, while the jogging motor rotates. Each plate spring on the jogging bar pushes the rack in the direction of the pinion gear, so that the rack and pinion gears meet securely. The distance of the offset bar movement depends on paper size, A4 or letter.

Detection of fixed position

The fixed position of the jogging bar is detected by the jogging home position sensor and a sensor flag united with the pinion. The fixed position is set when the sensor detects the sensor flag. This fixed position is used as a reference point to calculate the distance of the movement of the jogging bar and offset bar depending on paper size.

Stapling mechanism

The stapler motor rotation drives a gear link and cam mechanism. The cam movement allows the stapler mechanism to operate.

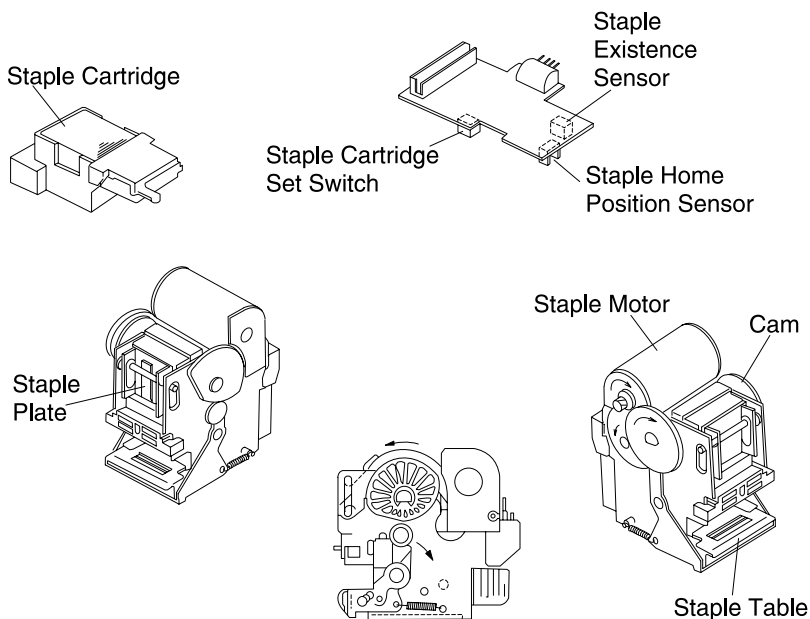

Elevator sequence

The wire drum rotates by the elevator motor as the wire drum rolls the wire pulling the hook plate up and down. The lower tray moves up by the driving force of the elevator motor until the elevator upper limit sensor is ON, the paper feeds onto the tray, or until the paper upper level sensor B is ON if no paper feeds onto the tray. When paper feeds out to the lower tray and the paper full sensor A turns ON, the lower tray moves down until the paper full sensor A

turns OFF. If paper feeds onto the lower tray when the elevator lower limit sensor turns ON, and the paper upper level sensor B turns ON, paper feeding from host printer is prohibited. When paper is removed from the lower tray and the paper upper level sensor B turns OFF, the lower tray moves up.

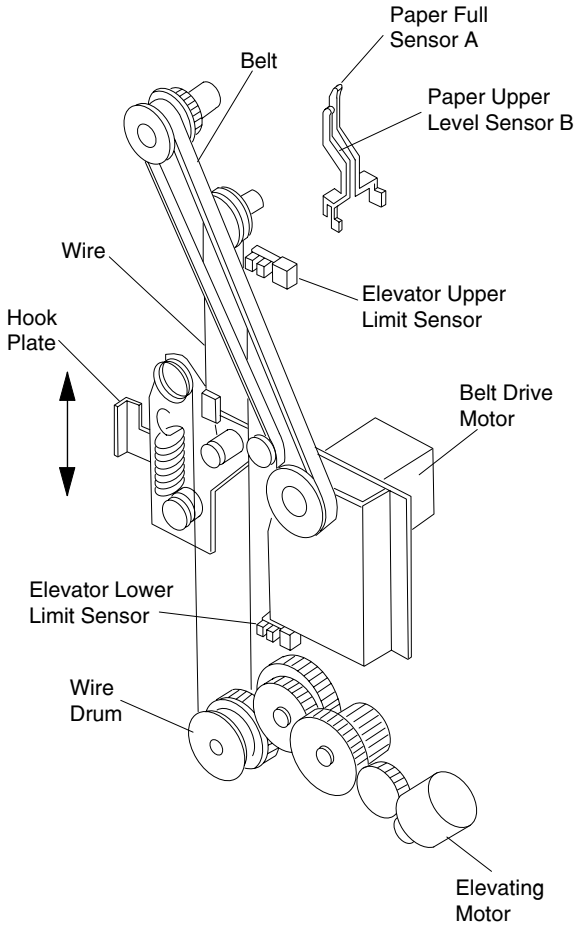

Finisher installation

Attaching the docking plate and guide rail

1. Lift the printer exit tray halfway and remove. You will need the tray when the finisher is attached.

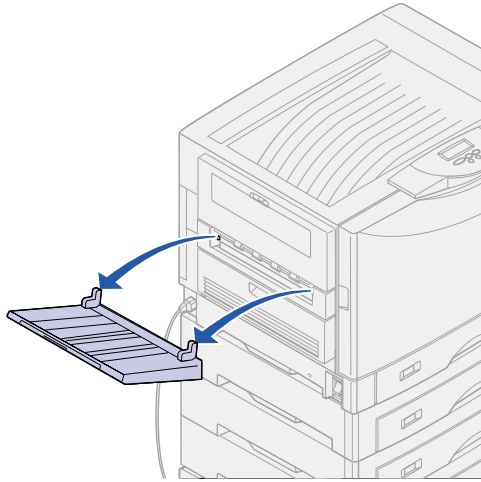

2. Insert the docking plate tabs into the printer.
3. Align the thumbscrews on the docking plate with the holes in the side of the printer.
4. Tighten the docking plate thumbscrews.
5. Align the thumbscrews on the guide rail plate with the holes in the side of the printer cabinet or stand.

6. Tighten the guide rail plate thumbscrews.

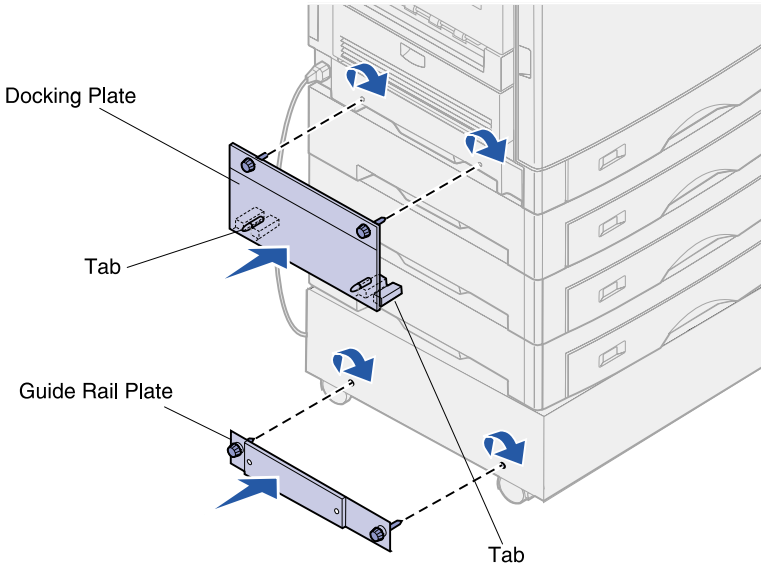

7. Align the thumbscrews on the guide rail with the holes in the guide rail plate.
8. Tighten the guide rail thumbscrews.

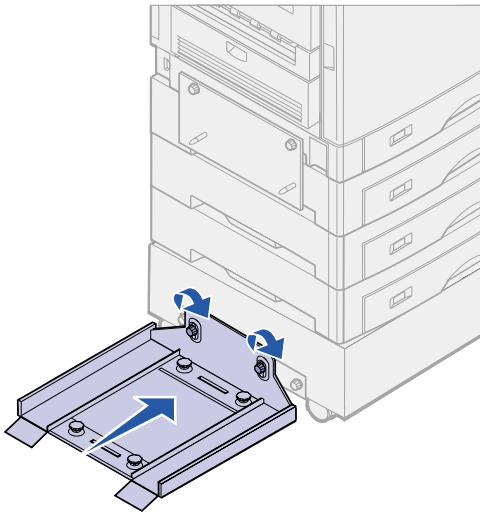

Combining the finisher and stand

1. Roll the finisher stand onto the guide rail. Do not push the stand all the way up against the printer.

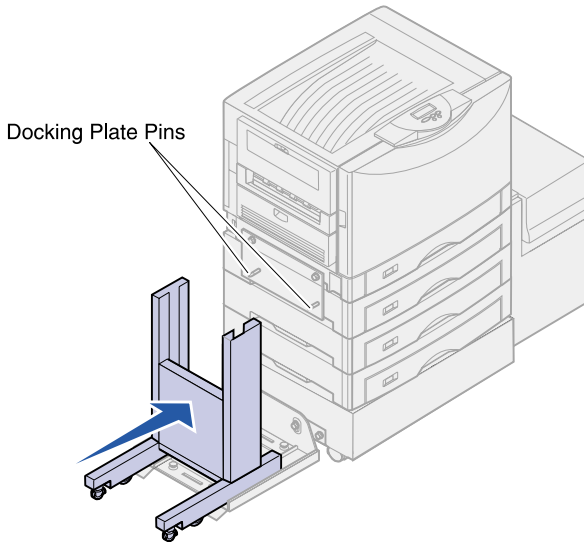

2. Remove and discard all shipping tape, packing material, and the metal shipping bracket.
- CAUTION:** The finisher weighs 19.7 kg (42.2 lb).

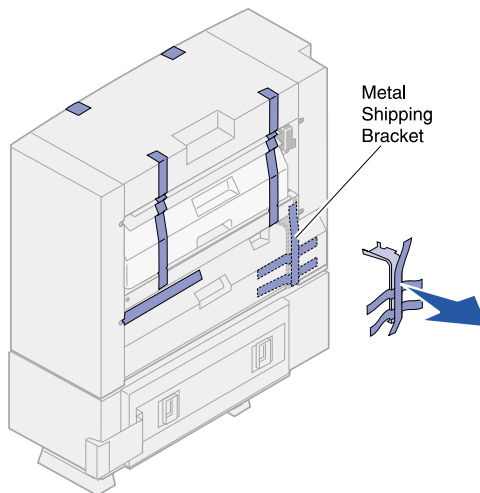

5055-xxx

3. Open the stapler door.
4. Remove all shipping tape and packing material.

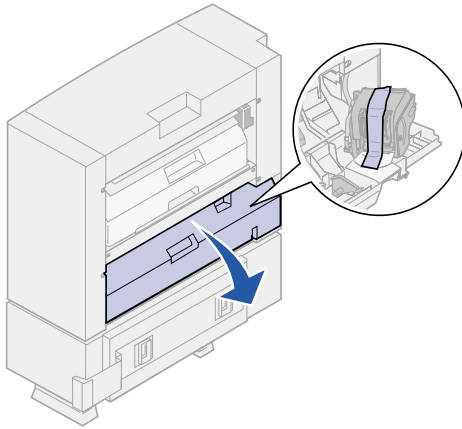

5. Lift the stapler locking lever.
6. Raise the stapler.
7. Remove all shipping tape and packing material.

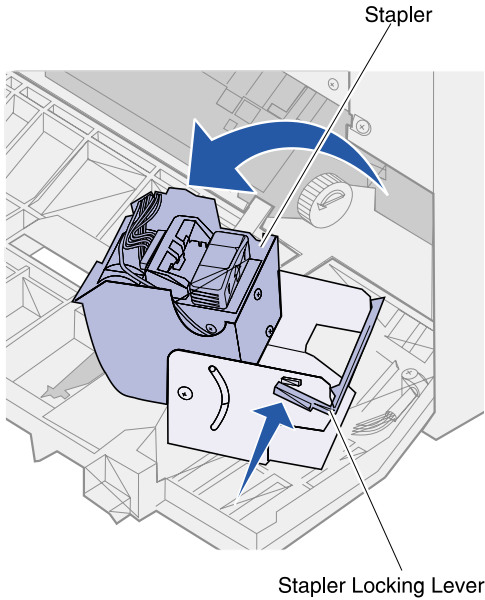

8. Close the stapler.

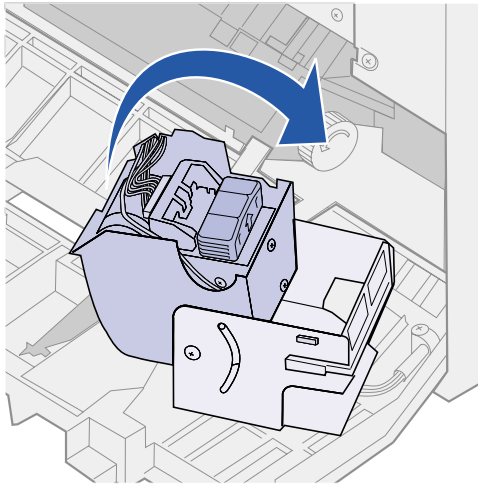

9. Close the stapler door.

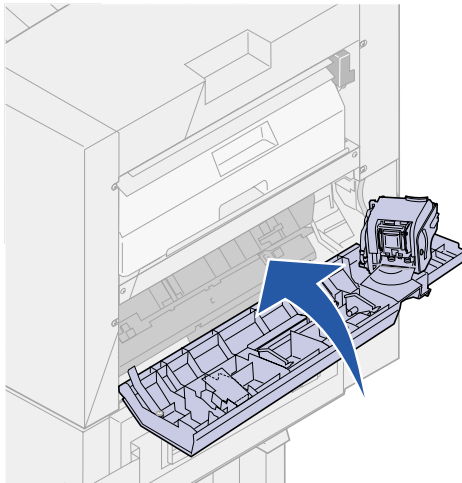

10. Align the two sockets on the bottom of the finisher with the legs of the finisher stand.

11. Lower the finisher onto the finisher stand.

CAUTION: When assembled, the finisher weighs 26.3 kg (56.9lb) and requires at least two people to lift it safely.

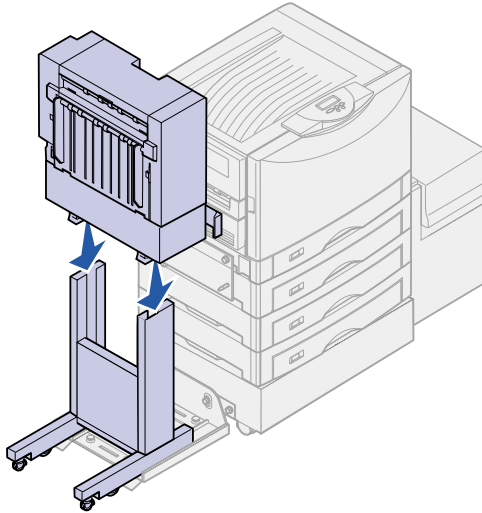

12. Remove both thumbscrew spacers.

13. Tighten the two thumbscrews.

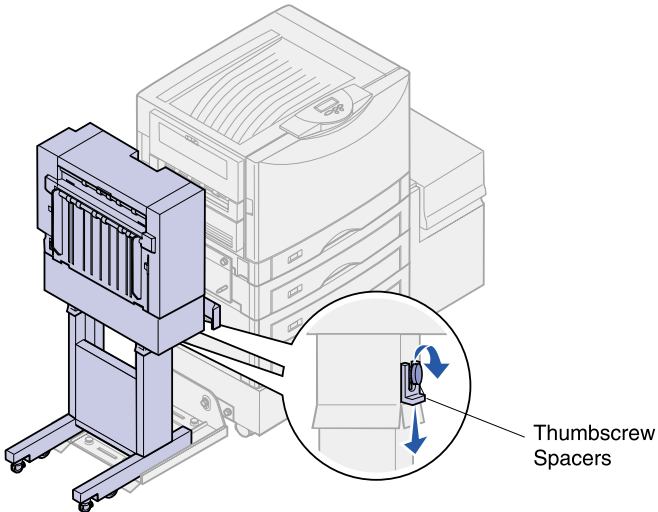

Attaching the bins

1. Align the slots on bin 2 with the metal brackets on the rear of the finisher.
2. Slide the bin down onto the metal brackets until it is fully seated.

Note: When assembled, the finisher and finisher stand are referred to as the finisher.

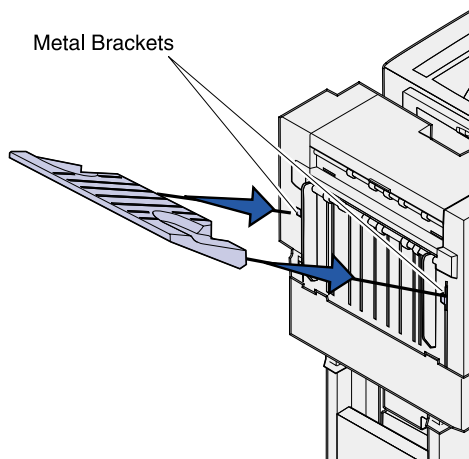

3. Align the tabs on bin 1 with the slots on the rear of the finisher.
4. Lower the bin until it is fully seated.

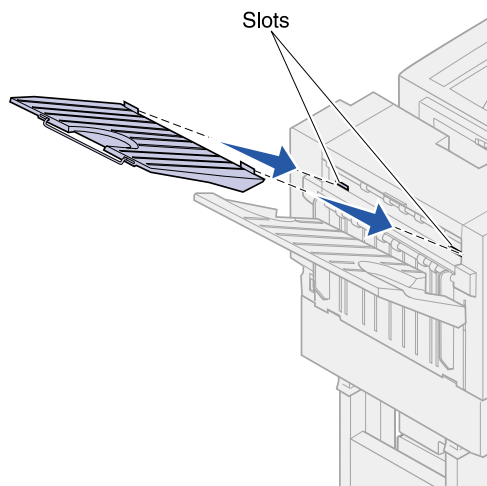

Aligning the finisher and printer

The following three areas must align properly to prevent paper jams.

1. The docking plate pins must enter the holes in the finisher.
2. The space between the printer and finisher must be the same at the top and bottom of the finisher.
3. The alignment marks on top of the finisher must align with the edges of the cover on the side of the printer.

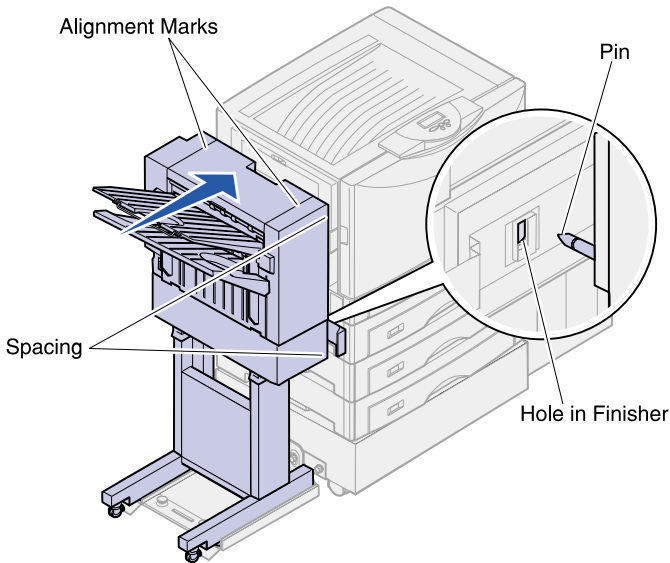

4. Roll the finisher toward the printer until the finisher locks to the docking plate pins.

You hear a click when the finisher locks into position.

If the pins did not go into the holes in the finisher, go to **“Lowering or raising the finisher” on page 3-82**. Otherwise, go to **“Aligning the sides of the finisher” on page 3-84**.

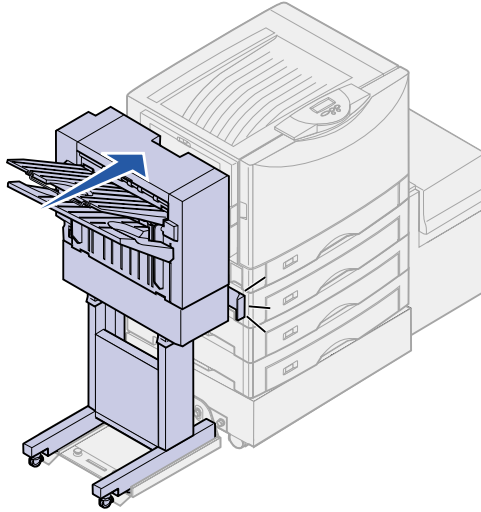

Lowering or raising the finisher

Follow these instructions if the holes on the finisher are above or below the pins on the docking plate.

1. Determine if the pins are above or below the holes in the finisher.

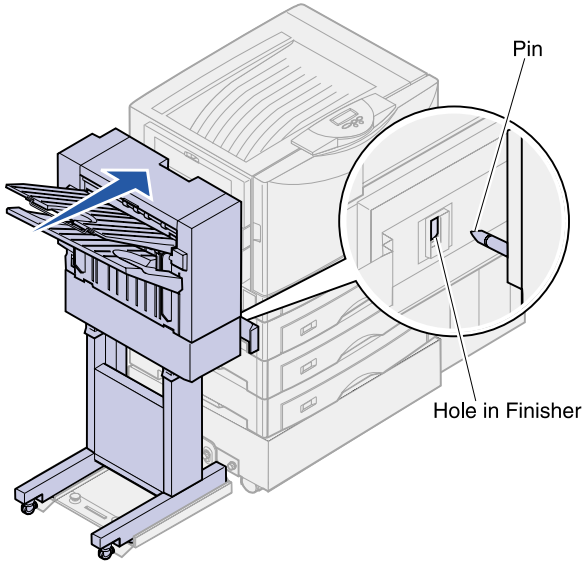

2. Loosen the guide rail thumbscrews.

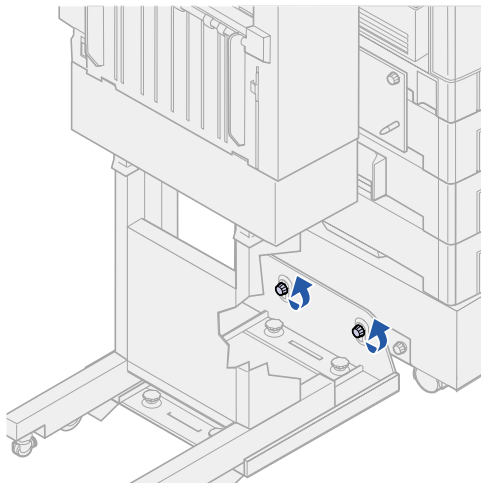

3. Rotate the adjustment knobs as needed to align the holes in the finisher with the pins.
 - To raise the finisher, rotate the adjustment knobs clockwise.
 - To lower the finisher, rotate the adjustment knobs counterclockwise.
4. Roll the finisher toward the printer until the finisher locks to the docking plate pins.

You hear a click when the finisher locks into position.

If the pins go into the holes but the finisher did not lock to the pins, go to **“Aligning the sides of the finisher” on page 3-84**. Otherwise, go to **“Aligning the top of the finisher” on page 3-86**.

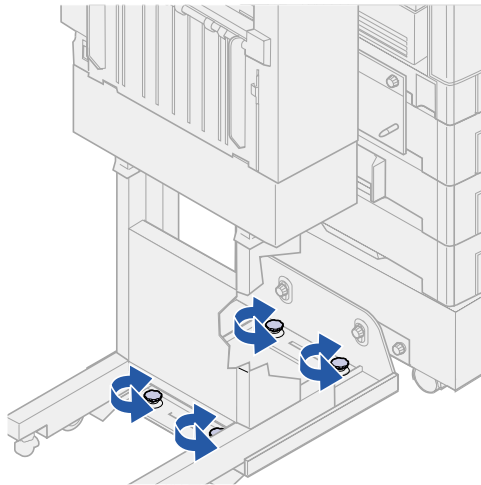

Aligning the sides of the finisher

Follow these instructions if the distance between the finisher and printer is not the same at the top and bottom.

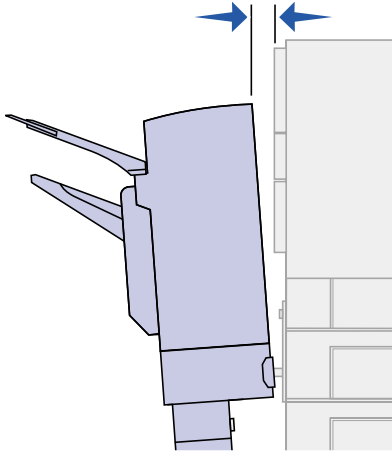

1. Loosen the guide rail thumbscrews.

If you previously lowered or raised the guide rail plate, the thumbscrews are already loose.

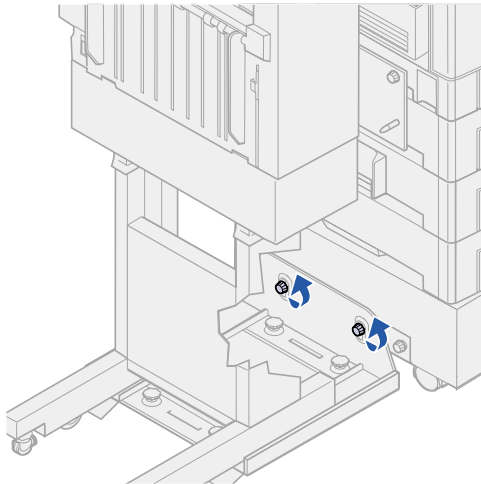

2. Rotate the rear adjustment knobs to equally align the top and bottom of the finisher with the printer.
 - To move the top of the finisher closer to the printer, rotate the adjustment knobs clockwise.
 - To move the top of the finisher away from the printer, rotate the adjustment knobs counterclockwise.

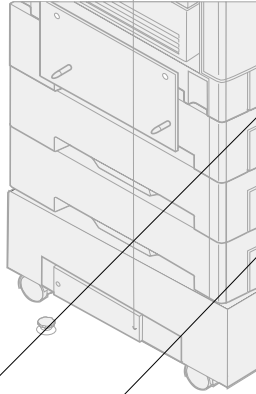

3. Roll the finisher toward the printer until the finisher locks to the docking plate pins. You hear a click when the finisher locks into position.

Aligning the top of the finisher

Note: Anytime you move the printer or finisher, recheck the printer and finisher top alignment.

Follow these instructions if the alignment marks on top of the finisher are not aligned with the edges of the cover on the side of the printer.

1. Loosen the guide rail thumbscrews.

If you made previous adjustments, the thumbscrews are already loose.

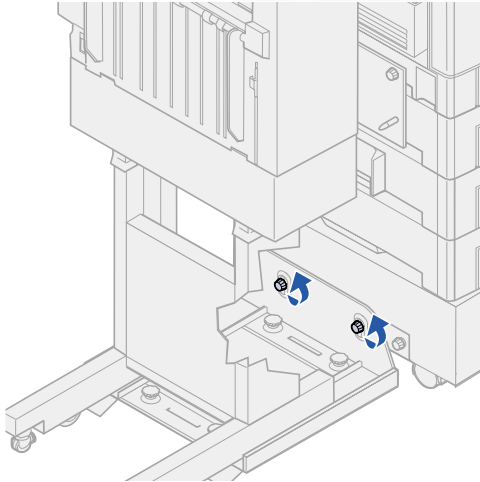

2. Rotate the adjustment knobs as needed to raise or lower the side of the finisher.
 - To raise the finisher, rotate the adjustment knobs clockwise.
 - To lower the finisher, rotate the adjustment knobs counterclockwise.
3. Tighten the guide rail thumbscrews.

4. Roll the finisher toward the printer until the finisher locks to the docking pins.

You hear a click when the finisher locks into position.

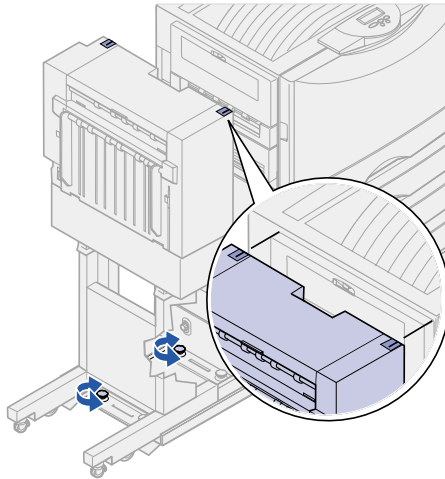

Adjusting the wheels

Adjust the wheels on the end of the finisher so the stand remains aligned when moved.

To adjust and lock the wheels:

1. Rotate the left and right upper adjustment knobs on the rear wheels until the wheels touch the floor.

To lower the wheels, rotate the adjustment knobs clockwise.

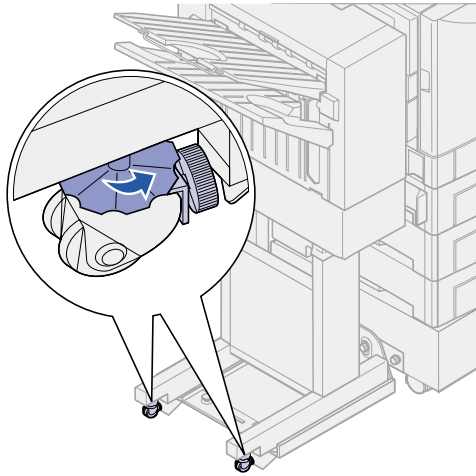

2. Turn the wheels until the locking knobs are aligned with the finisher base.

3. Rotate the locking knobs counterclockwise until they contact the finisher base.

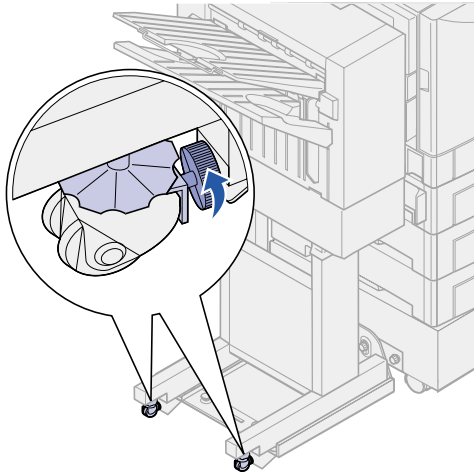

Attaching the cables

The finisher comes with an interface cable and Y-power cord. The interface cable connects the finisher to the printer, and the Y-power cord provides electrical power to the finisher and printer.

1. Turn the printer off and unplug the power cord from the power outlet.
2. Push the latch in and hold it.
3. Roll the finisher away from the printer.
4. Release the latch.

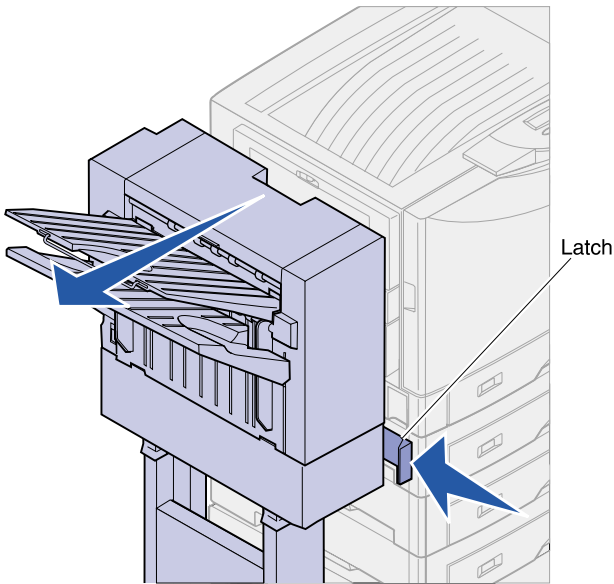

Interface cable

CAUTION: Make sure the printer is turned off before continuing.

1. Plug the interface cable into the bottom connector on the back of the printer.
2. Tighten the thumbscrews.

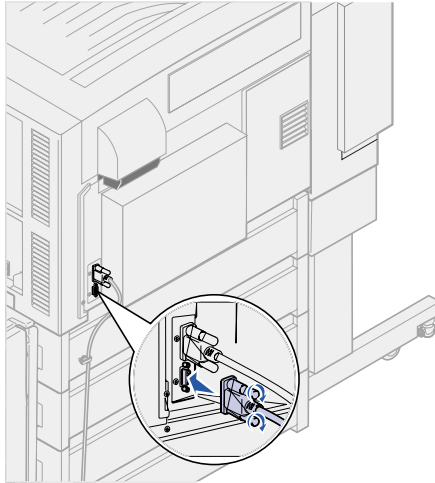

3. Plug the interface cable into the connector on the side of the finisher. The plug will be on a slight angle when connected.
4. Tighten the thumbscrews.

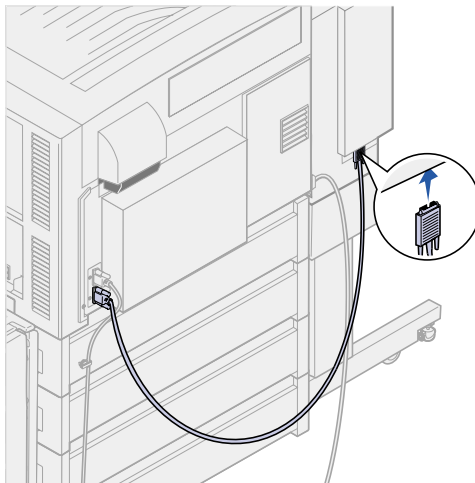

Power cable

1. Unplug the power cord from the side of the printer.
Set the cord aside.

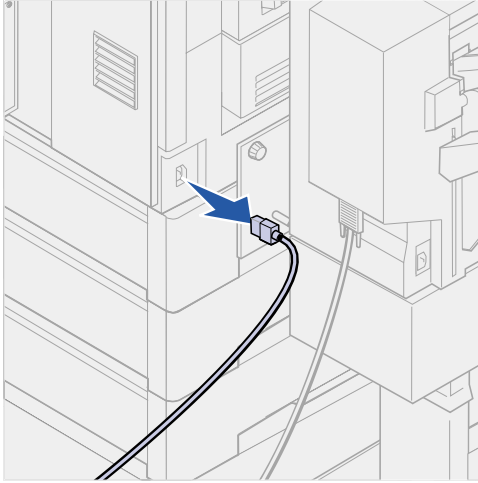

2. Plug the straight Y-power cord connector into the socket on the side of the finisher.
3. Plug the angled connector of the Y-power cord into the socket on the side of the printer.

4. Connect the previously removed printer power cord to the Y-power cord.

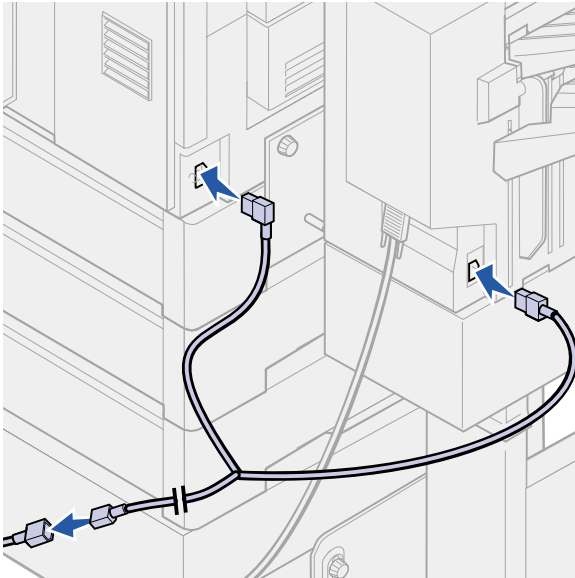

5. Remove the protective paper from the back of the cable holder.
6. Firmly press the adhesive-backed cable holder onto the back of the top optional drawer.

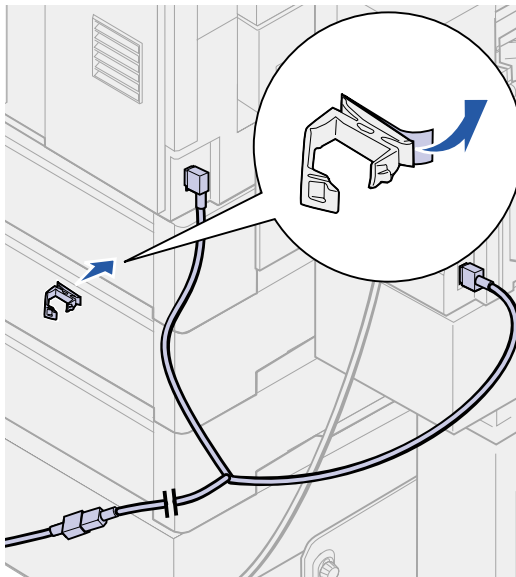

7. Place the finisher interface cable and power cord into the cable holder.
8. Close the cable holder.
9. Replug the power cord into the outlet and turn the printer on.

The finisher does not have a power switch. Power is controlled by the printer.

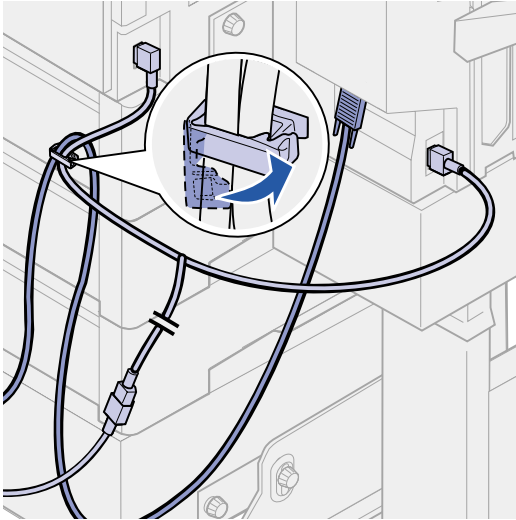

Hole punch adjustment

You can adjust the hole punch alignment by approximately 4 mm (3/16 in.). This adjustment is useful when you want to center the punched holes onto the paper or if you hole punch a printed job on different finishers.

Note: The following procedures are used for both three and four hole punch finishers.

1. Verify the alignment of the printer and finisher is correct.
 - If the alignment is not correct, go to **“Aligning the finisher and printer” on page 3-80**, and then print and hole punch another sheet of paper and see if an adjustment is needed.
 - If an adjustment is needed, continue with step 2.
2. Using a sheet of paper previously punched from the finisher, fold the paper so the bottom punched hole is aligned with the top punched hole.

3. Determine if the edge of the bottom of the page is below or above the top edge of the page.
4. Loosen the guide rail thumbscrews.
Note: Do not move the adjustment knobs more than three complete turns from their starting position. Adjustments greater than three turns may cause paper jams.
5. Rotate both adjustment knobs the same amount to raise or lower the side of the finisher.
 - A half turn of the knob moves the position of the hole approximately one third to one half the distance of the punched hole.
 - To move the bottom of the paper down, rotate the knobs clockwise.
 - To move the bottom of the paper up, rotate the knobs counterclockwise one quarter turn.
6. Tighten the guide rail thumbscrews.
7. Print and punch another piece of paper.
8. Repeat steps 2 and 3. If the holes are not aligned repeat steps 3 through 8.

5055-xxx

4. Repair information

Service precautions

Observe the following precautions whenever you service the printer:

- Be sure to unplug the printer from the outlet before attempting to service the printer.
- To reassemble the printer, reverse the order of disassembly unless otherwise specified.
- Do not operate the printer anytime during disassembly. If it is absolutely necessary to run the printer with its covers removed, use care not to allow your clothing to be caught in revolving parts such as the gears, rollers, and fan motor.
- Never touch the terminals of electrical parts or high-voltage parts such as the high voltage power supply board.
- Be sure to handle the fuser carefully as it remains hot for a while after the printer stops running. Always unplug connectors by holding the connector housing.
- Be sure to use the fuse listed in the parts catalog.
- Do not forget to install the ground wire or ground plate to ensure positive conduction. Install the screw with a toothed washer in the correct position at reassembly.

Handling printed circuit boards

The following precautions must be observed when handling circuit boards with metal oxide semiconductor integrated circuits.

Transportation/storage:

- During transportation or when in storage, new circuit boards must not be indiscriminately removed from their protective conductive bags.
- Do not store or place circuit boards in a location exposed to direct sunlight.
- When it becomes absolutely necessary to remove a board from its conductive bag or case, always place it on its conductive mat in an area as free as possible from static electricity.
- Do not touch pins of the integrated circuits with your bare hands.

Replacement:

- Before you unplug connectors from the circuit boards, be sure the power cord has been unplugged from the power outlet.
- When you remove a board from its conductive bag or case, do not touch the pins of the integrated circuits or the printed pattern. Place it in position by holding only the edges of the board.
- Before you plug connectors into the board, be sure the power cord has been unplugged from the power outlet.

Inspection:

- Avoid checking the integrated circuits directly with a multimeter; use connectors on the board.
- Never create a closed circuit across integrated circuits pins with a metal tool.
- When it is absolutely necessary to touch the integrated circuits and other electrical components on the board, be sure to ground your body.

Adjustments

High-capacity paper feed timing belt adjustment

1. Secure the bracket with the screw, as shown.
2. Attach the spring and washer to the bracket with the screw.
3. Adjust the screw to $6\text{mm} \pm 1\text{mm}$.
4. Tighten the screw completely.
5. Adjust the timing belt on the rear in the same manner.

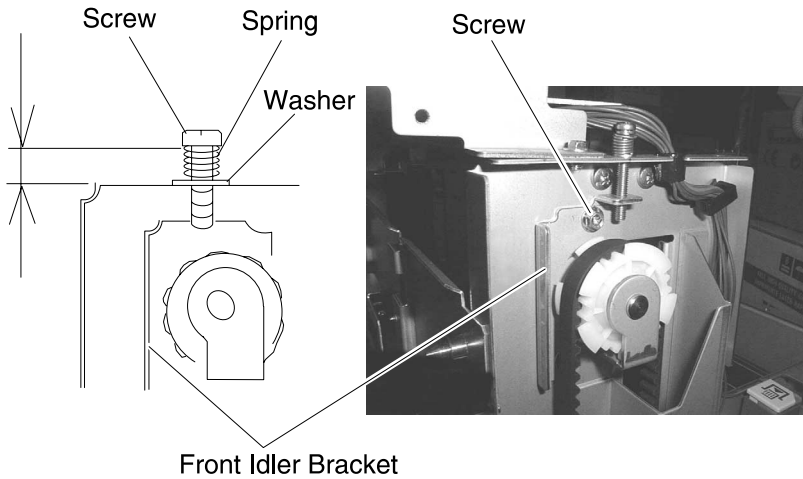

Removals

Cover, top removal

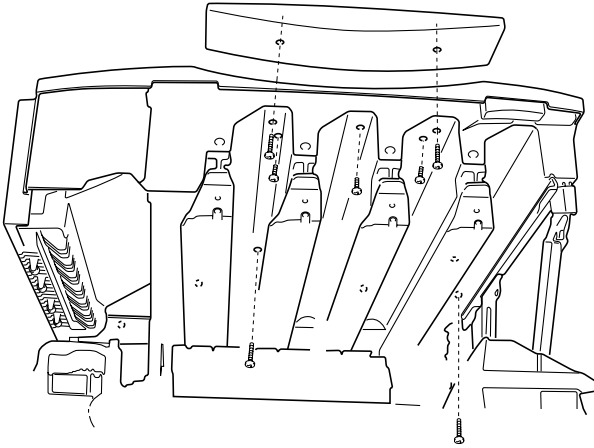

1. Open the top unit and remove the photodevelopers and toner cartridges.
2. Remove the two silver screws and remove the operator panel.
3. Remove five black screws from the bottom and the four silver screws from the back side.
4. Remove the top cover.

Cover, front removal

1. Remove the four brass hinge screws from the front cover.

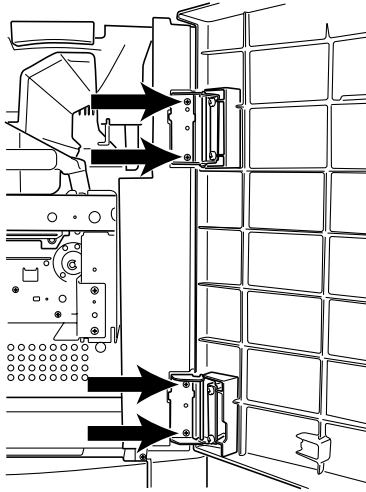

2. Remove the front cover

Cover, front left removal

1. Open the front cover and remove the cassette.
2. Remove the left front cover by removing the three silver screws.

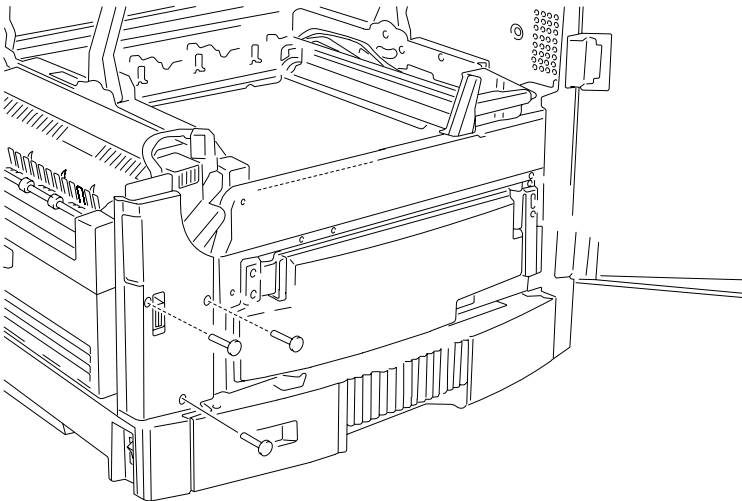

Cover, rear removal

1. Open the top unit.
2. Remove the three silver screws from the rear cover, and remove the cover.

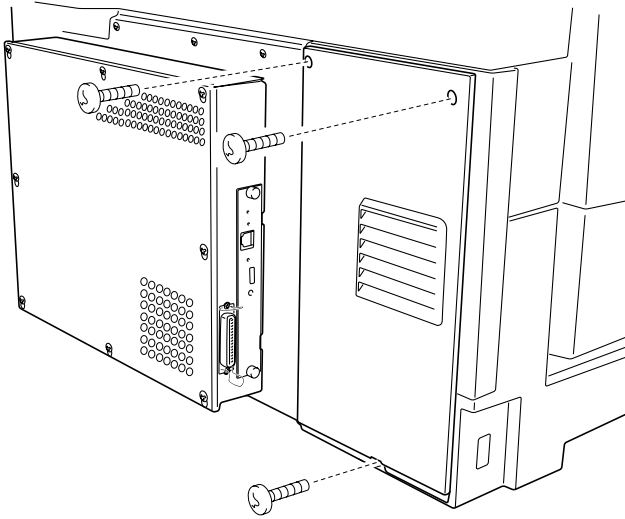

Cover, solenoid removal

1. Remove the screw from the solenoid cover.
2. Remove the solenoid cover.

Cover, left side removal

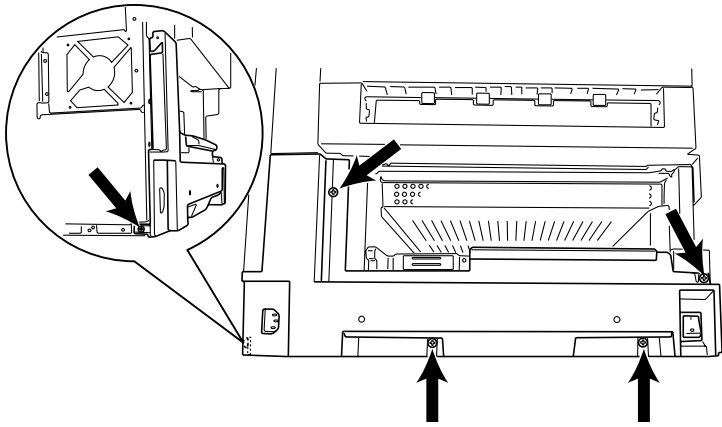

1. Remove the upper cassette, front cover, paper exit tray, and duplex unit.
2. Remove the five screws from the left side cover, and remove the cover.

Cover, right side removal

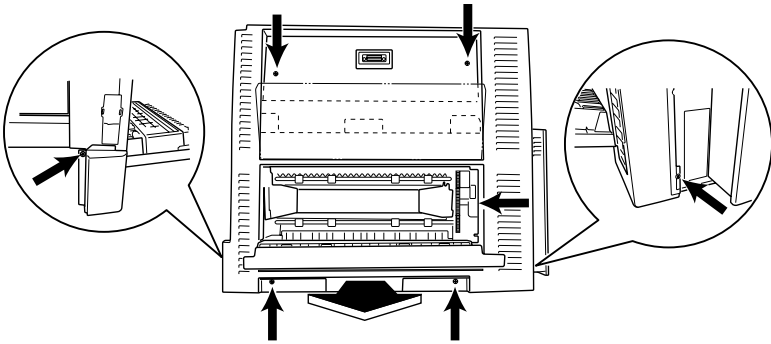

1. Open the top unit and remove the front cover and upper cassette.
2. Remove the seven screws from the right side cover together with the turn guide, and remove the cover.
3. When installing the right side cover, insert the turn guide shaft into the bearing.

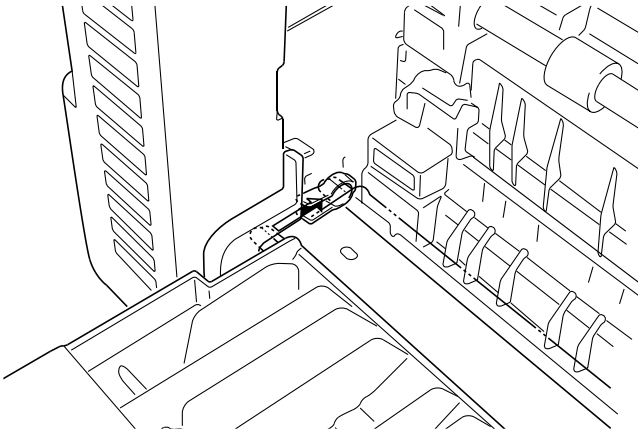

Cover, RIP board removal

1. Loosen the eight screws and remove the RIP cover by sliding upward.

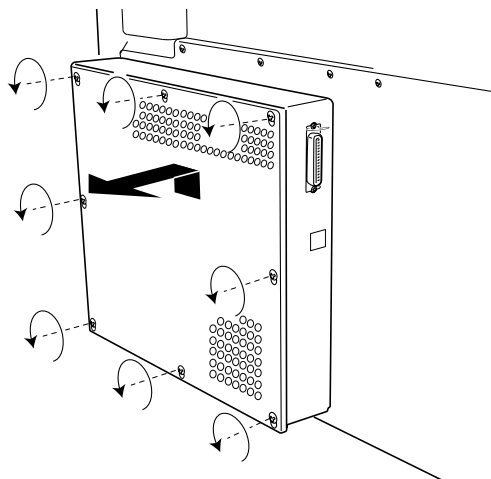

2. Remove the three harnesses and one flat cable of the RIP board connector.

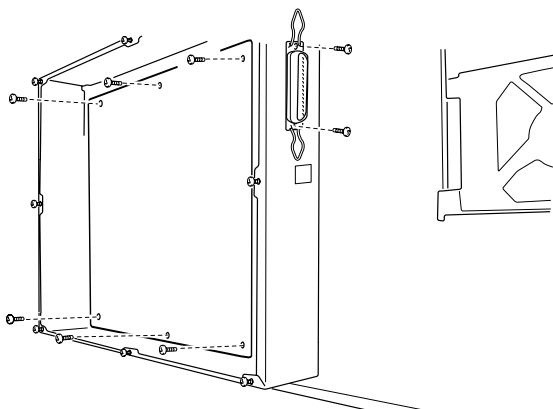

3. Remove the two screws from the parallel port connector and the screw from the USB connector.
4. Remove the eight screws from the RIP board together with the parallel connector, and remove the RIP board.

Tray, paper exit removal

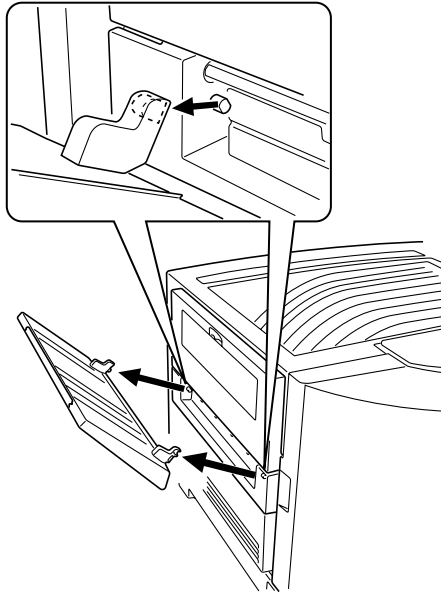

1. Unlatch the hinge at the back side, then unlatch the hinge on the front side.
2. Remove the paper exit tray.

Belt up/down clutch removal

1. Open the top unit and remove the RIP cover, RIP board, RIP box, and electronic box. Remove the printer controller. Remove the printer controller bracket and the high voltage power supply board.

2. Remove the C-clip from the belt up/down clutch, and remove the clutch.

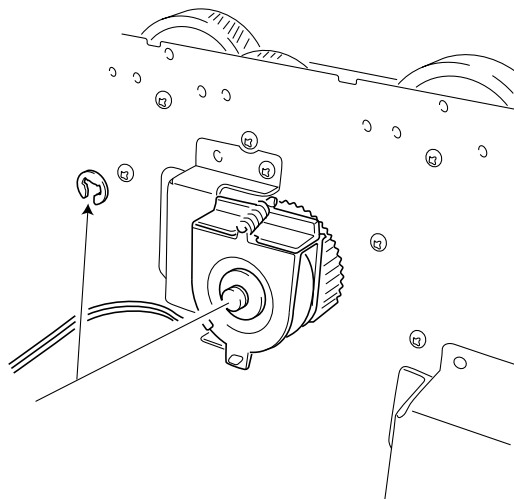

Belt up/down detection sensor removal

1. Open the top unit and remove the waste toner bottle and belt unit.
2. Remove the belt up/down detection sensor from the mounting board.
3. Remove the connector from the belt up/down detection sensor.

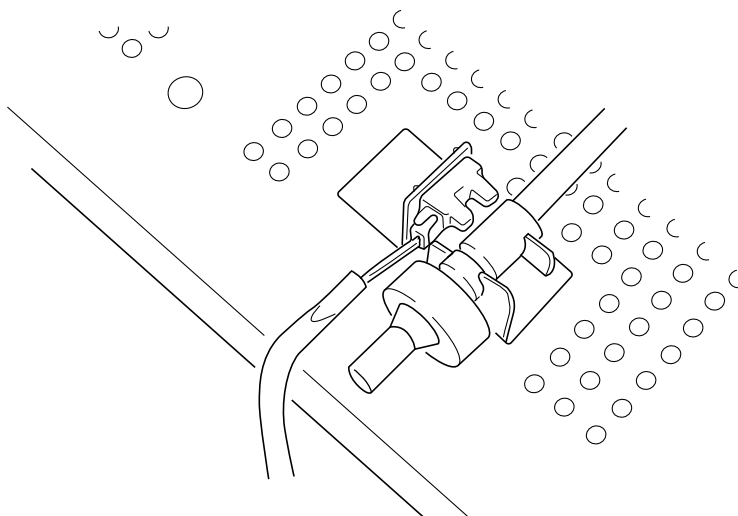

Cassette guide removal

1. Remove the paper feed frame.
2. Remove the front cover, cassette, turn guide, right side cover, and paper feed frame.
3. Remove the screws from the cassette guide, and remove the guide.

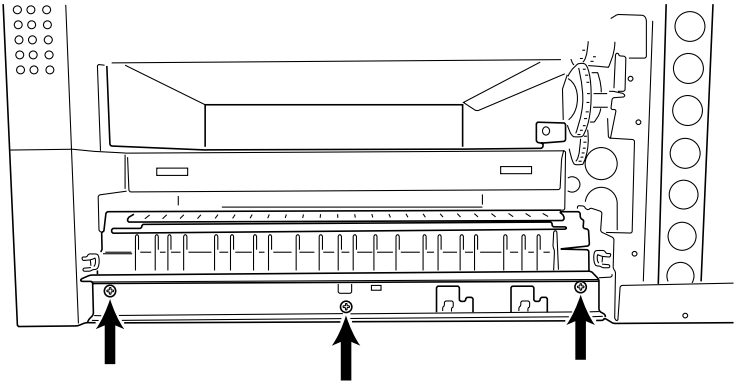

Connector, duplex unit removal

1. Open the top unit and remove the upper cassette, left front cover, paper feed cover, left side cover, RIP cover, RIP board, RIP box, and the electronic box. Remove the turn guide and open the paper feed cover and remove the duplex unit. Remove the left side cover and power supply A.
2. Disconnect the connector and remove the two screws from the mounting plate.
3. Remove the two screws of the drawer connector from the mounting plate drawer bracket.

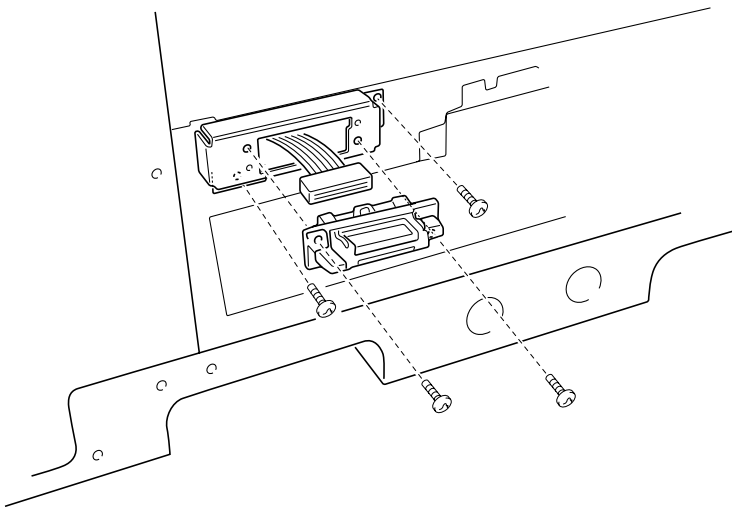

Density sensor removal

Separation fingers removal

Sensor cleaner removal

1. Open the top unit and remove the belt unit.
2. Remove the three screws from the sensor bracket.

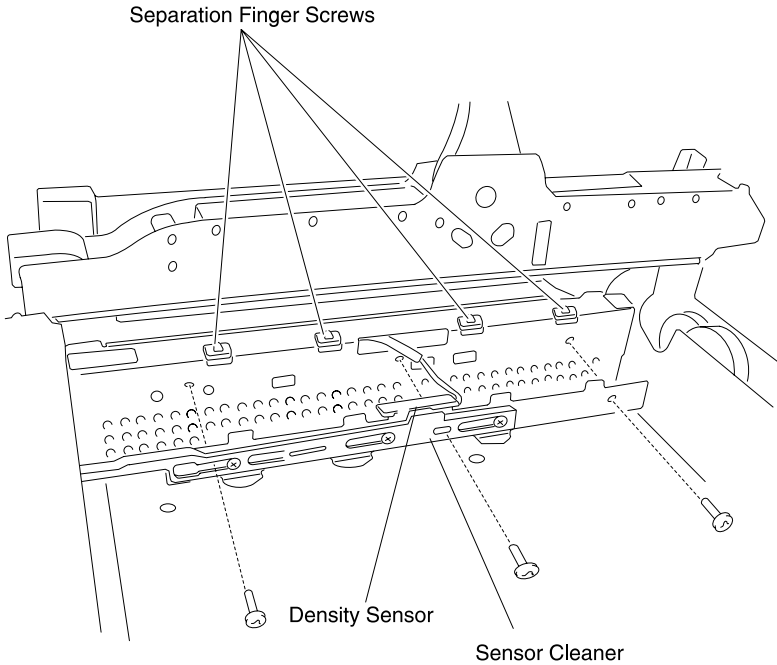

3. Remove the harness band and remove the two screws from the density sensor from the sensor bracket.
4. Remove the three set screws from the sensor cleaner assembly from the sensor bracket.
5. Remove the four separating finger screws from the fuser entrance guide.

Drive gear unit sensor assembly removal

1. Open the top unit and remove the gear cover, RIP cover, RIP board, RIP box, electronic box, printer controller, and high voltage power supply board.
2. Remove the screw from the drive gear unit sensor assembly.

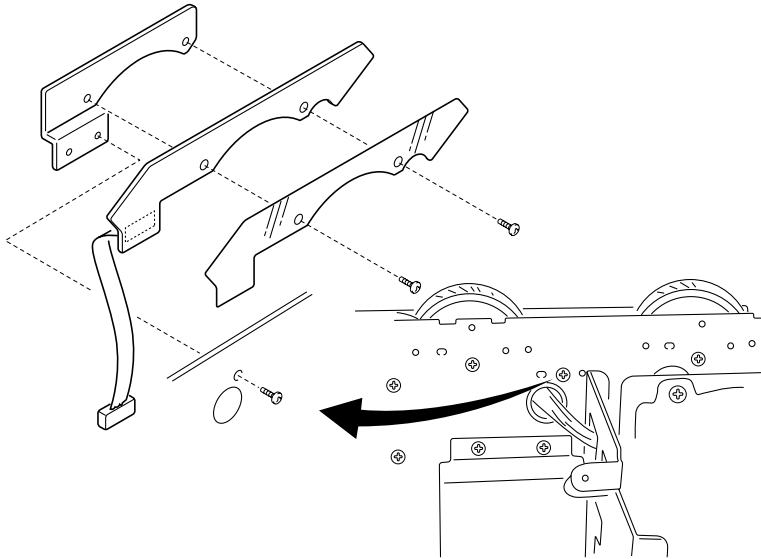

3. Remove the two screws of the drive gear unit sensor from the drum drive gear sensor assembly.

Drive motor assembly removal

1. Open the top unit and remove the RIP cover, RIP board, RIP box, and electronic box.
2. Remove the upper cassette, left front cover, and back cover.
3. Remove the turn guide.
4. Open the paper feed cover and remove the duplex unit.
5. Remove the side left cover. Remove the connector, two ground wires, and power supply 1.
6. Remove the connector (CN2, CN4 and CN5) from the motor drive board.
7. Remove the four screws with spring washers from the drive motor.

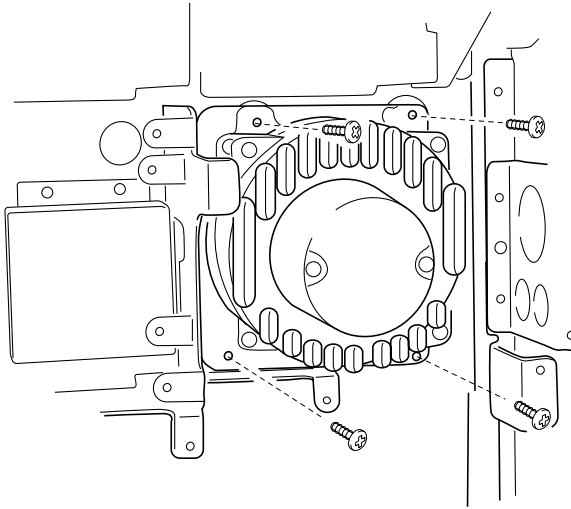

Note: When installing, hold the motor securely and mount the screws.

Electronic box removal

1. Open the top unit and remove the back cover.
2. Remove the RIP board cover.
3. Remove the RIP board.
4. Remove the screws from the electronic box.
5. Disconnect the two cables from the rear of the electronic box and remove the box.

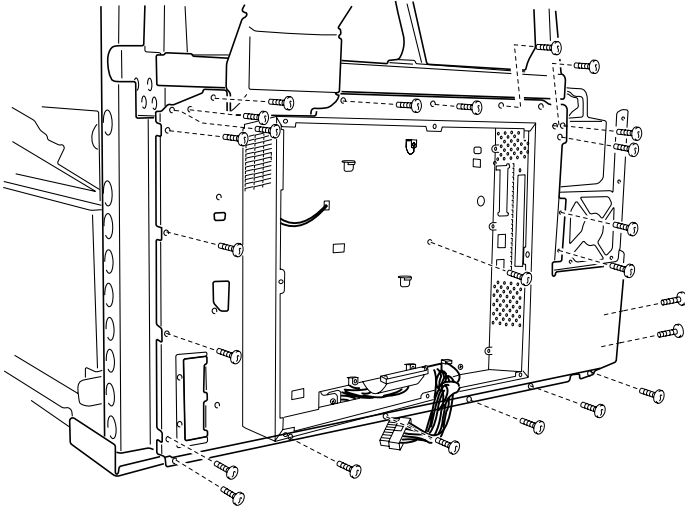

Face down guide assembly removal

Paper exit motor and full sensor removal

1. Open the top unit and remove the toner cartridges, photodeveloper drum units, and upper cover.
2. Remove the top cover.
3. Disconnect the connector and remove the five screws and two snap bands from the face down guide assembly.

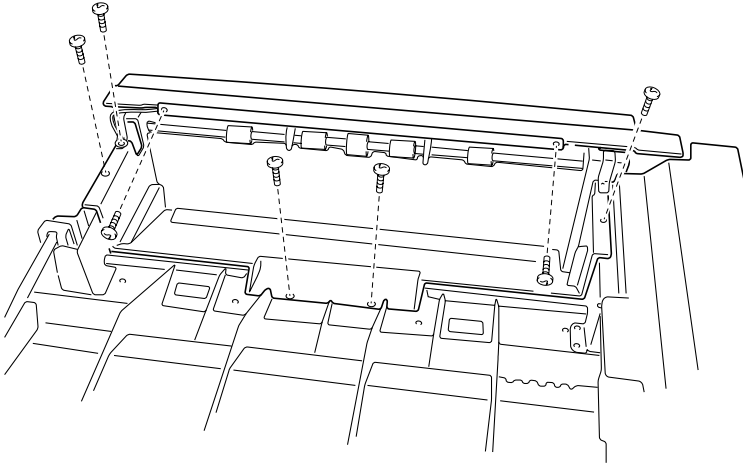

4. Remove the four screws from the face down cover and the face down guide assembly, and remove the assembly.

Face up paper exit assembly removal

1. Open the top unit and remove the upper cassette. Open the duplex cover and remove the duplex unit.
2. Remove the left front cover, left side cover, and rear cover.
3. Remove the three screws from the face up delivery assembly and remove the assembly.

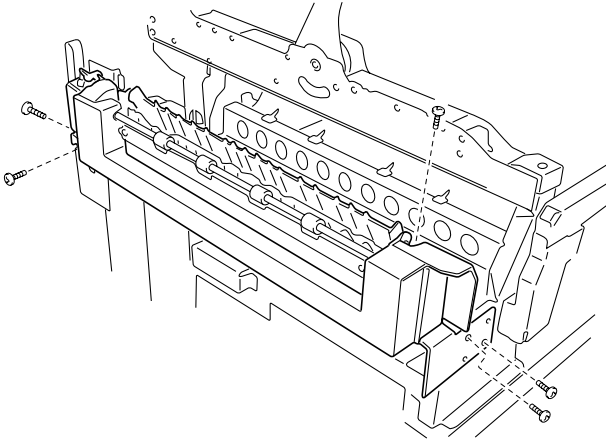

Fanning pad removal

1. Open the top unit and remove the upper cassette, front cover, turn guide, multipurpose feeder, right side cover, and multipurpose feeder roll.
2. Release clips at 4 positions and remove the fanning pad.

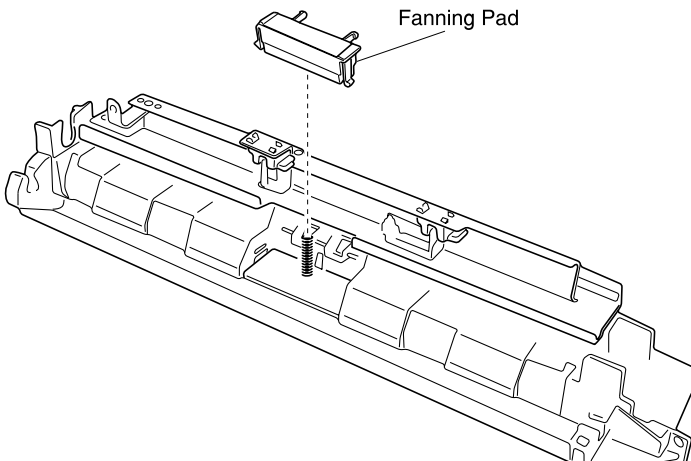

Front cover open switch actuator removal

1. Open the front cover.
2. Remove the two screws from the front cover open switch actuator.

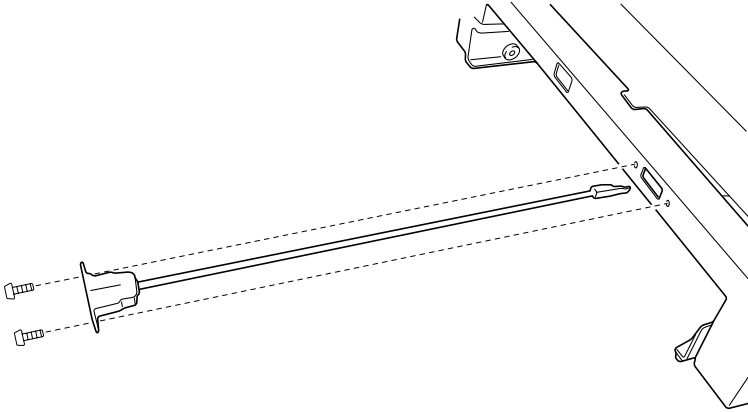

Fuser removal

1. Open the top unit.
2. Pushing the front and back lock, hold the handle, raise and remove the fuser.

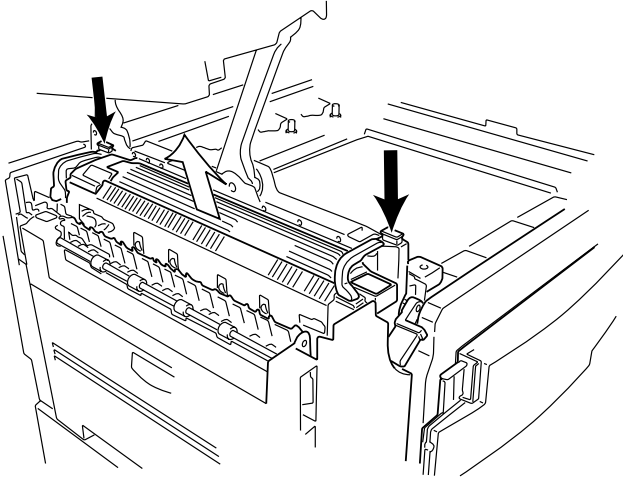

Gear cover removal

Multipurpose feeder frame assembly

1. Open the top unit, and remove the upper cassette, front cover, multipurpose feeder, right side cover, and turn guide.
2. Remove the two screws from the gear cover, and remove the cover.

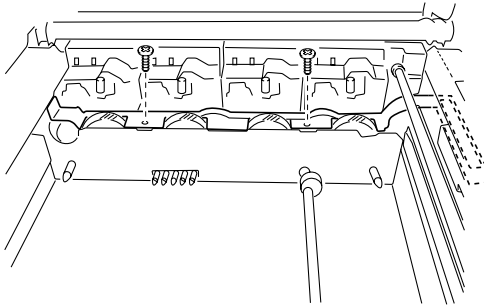

3. Remove the four screws from the multipurpose feeder frame and the ground screw.

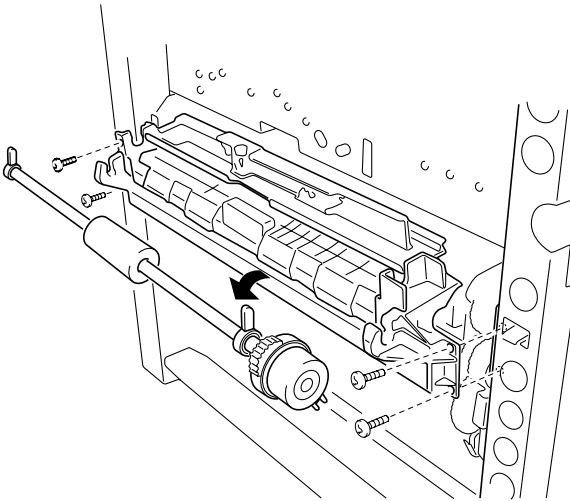

4. Disconnect the connector of the multipurpose feeder paper feed sensor.
5. Pull out the multipurpose feeder frame slightly.

6. Remove the screw from the OHP detection sensor (upper).

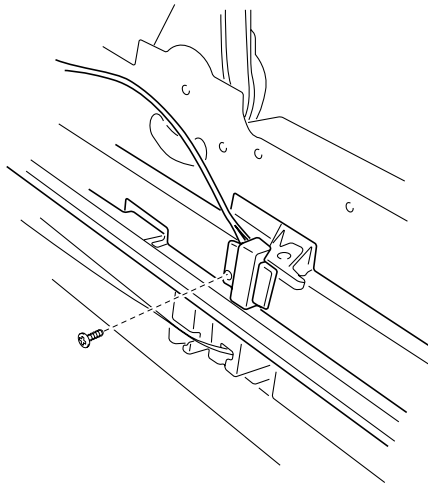

7. Turn the bearing stopper of the multipurpose feeder roll forward 1/4 turn and remove upward.
8. Remove the multipurpose feeder frame assembly.

High voltage power supply board (HVU) removal

1. Open the top unit and remove the RIP cover, RIP board, RIP box, electronic box, and printer controller board.
2. Remove the five screws from the printer controller board bracket.
3. Remove the connectors and remove the 12 screws.
4. Remove the high voltage power supply board.

LED printhead removal

1. Open the top unit, remove the top cover, toner cartridges, and photodeveloper drum units.

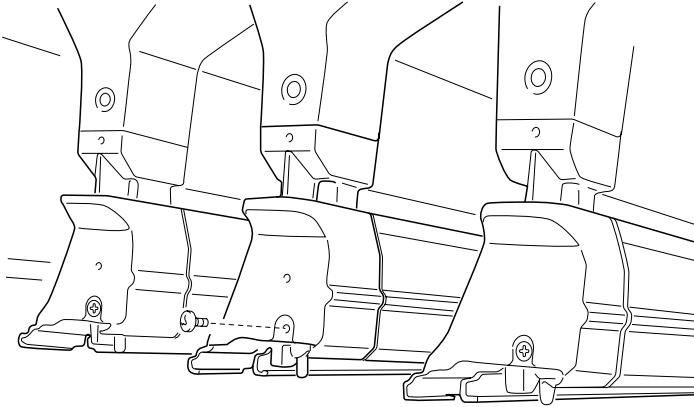

Note: Remove the transfer belt, or spread a cloth or paper over the transfer belt to protect it from damage.

2. Remove the short black screw from the printhead holder, and remove the holder.
3. Remove the front and rear printhead springs.
4. Remove the two screws (front and rear) from the right slide rail, and remove the rail.

Note: For printers with serial numbers XX-1XXXX and above, go to step 7. For serial numbers XX-0XXXX, continue with step 5.

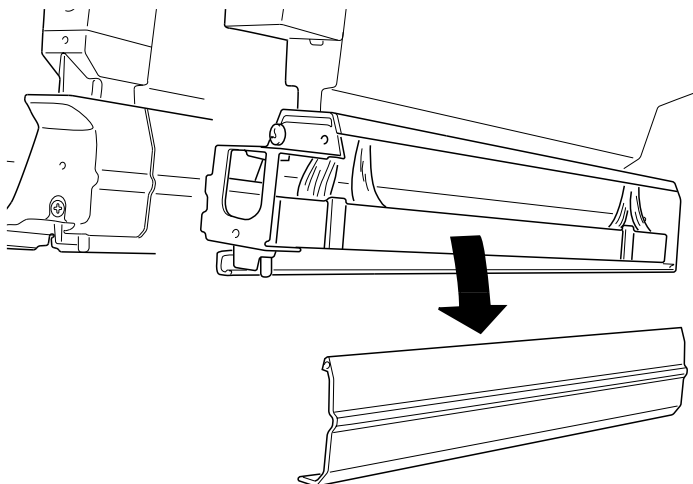

5. **For printers with serial numbers XX-0XXXX and above:**
Remove the four connectors from LED printhead.
6. Remove the two screws from the ground wires.

C910, C912 S/N's XX-0XXXX

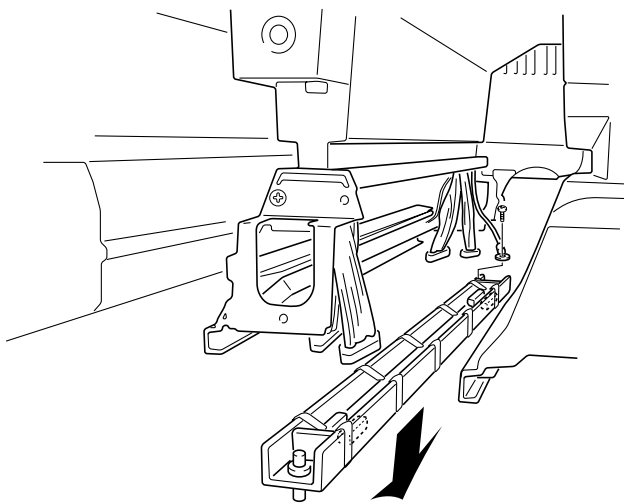

When replacing the LED printhead, replace the corresponding EEPROM shipped with the printhead, on the printhead controller board. Place the printer in **Diagnostic Mode**, input the printhead light quantity value plus **eight** (refer to note below) from the printhead label. Be sure to remove any fingerprints or stains from the printhead lens. The positioning pins at the both ends of the printhead are fixed with hexagon nuts. Do not loosen or remove either nut, as the image will unfocus.

Note: Light intensity value = printhead label value plus eight.

7. **For serial numbers XX-1XXXX and above:** Disconnect the affected LED printhead connectors from the printhead controller board. Remove the screw from the ground wire located on the LED printhead.

C912 S/N's XX-1XXXX

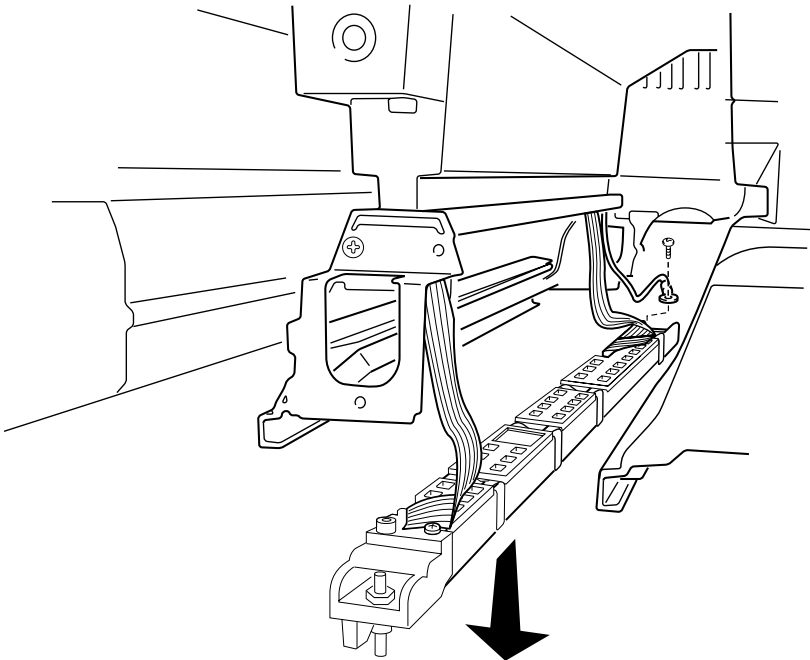

8. Remove the LED printhead and the cables from the printer. When replacing the LED printhead, replace the corresponding EEPROM shipped with the printhead, on the printhead controller board.

Note: The LED printhead light intensity values do not have to be entered for the printer S/N XX-1XXXX and above.

Eraser removal

1. Remove the appropriate printheads (see **“LED printhead removal” on page 4-24**). Spread a cloth or paper over the transfer belt to protect it from damage.
2. Remove the two screws from HSP holder, and remove the holder.

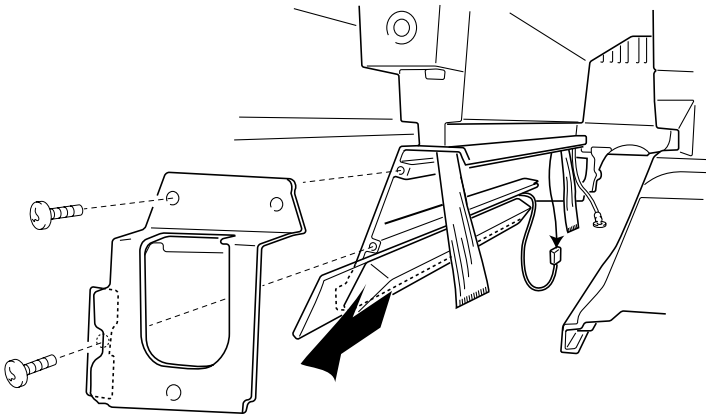

3. Remove the top cover.
4. Disconnect the connector (see arrow).
5. Remove the eraser.

Lock handle assembly removal

1. Open the top unit.
2. Turn the plastic latch on the front and rear sides 90°.
3. Remove the spring.
4. Remove the lock handle assembly.

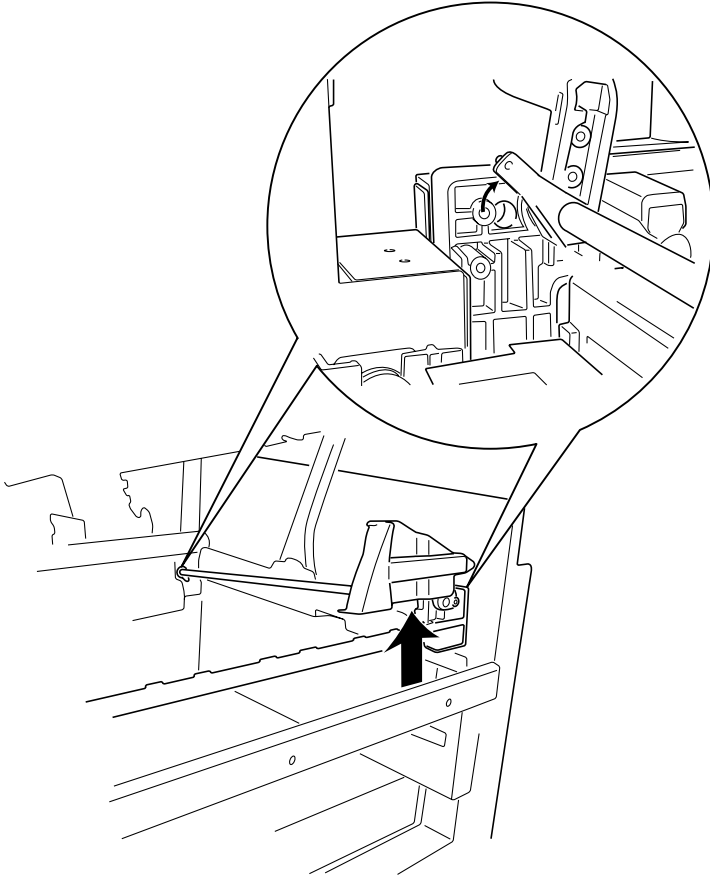

Main drive unit removal

1. Open the top unit and remove the gear cover, upper cassette, left front cover, paper feed cover, RIP cover, RIP board, RIP box, electronic box, and rear cover.
2. Open the turn guide and paper feed cover and remove the duplex unit.
3. Remove the left side cover, power unit 1, and power unit 2.
4. Remove the printer controller board.
5. Remove the bracket, high voltage power supply board, and sub frame R.
6. Remove the fuser unit, face up paper delivery unit, belt up/down clutch, and DC drive motor.
7. Remove the multipurpose feeder roll, registration roll, and paper carrying frame.
8. Remove the eight screws from the power supply 2 bracket.
9. Remove the two screws from the belt power supply 2.
10. Remove the two screws from the fan bracket.
11. Remove the three screws from the fuser connector plate.

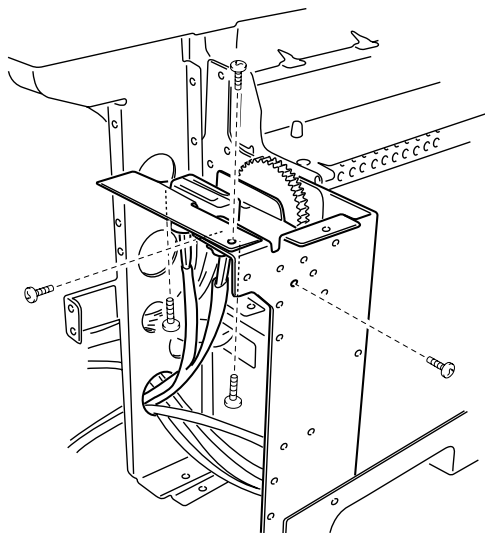

12. Remove the two screws of the fuser connector cable assembly from the fuser connector plate.

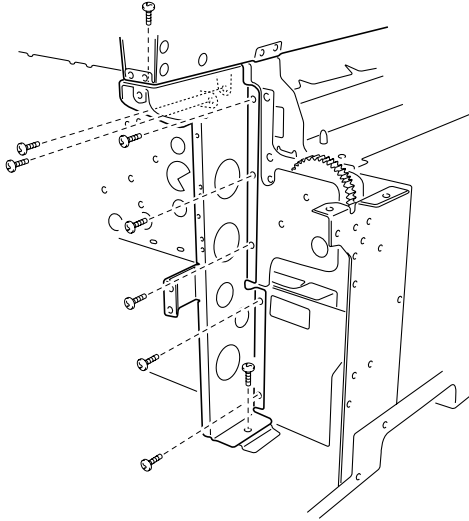

Note: Note the direction, when installing.

13. After removing the two screws on the bracket that attaches the rear side and paper exit side of the machine, remove the nine screws from the bracket.
14. Remove the bearing from the belt up/down switching shaft and remove the belt up/down switching shaft.

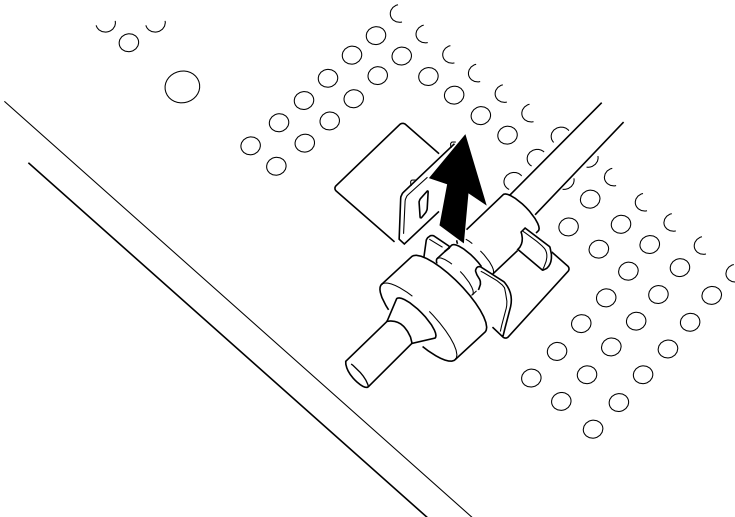

15. Remove the screw from the clutch stopper. The clutch stopper is attached to the ground plate with two screws.

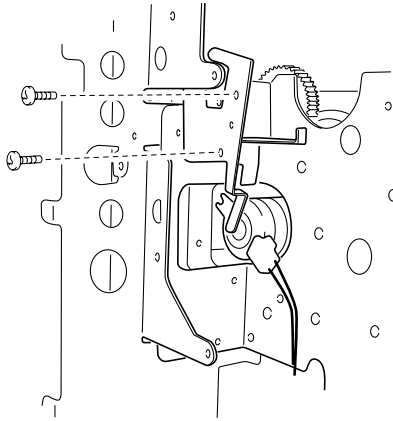

16. Remove the six screws on the right side.

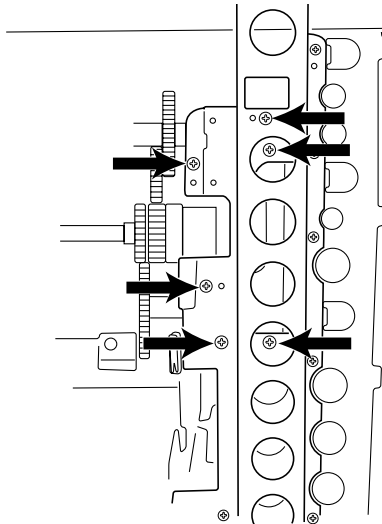

17. Remove the two screws from the drive unit, and remove the unit.

18. Remove the three screws from the belt up/down clutch box and remove the belt up/down clutch.

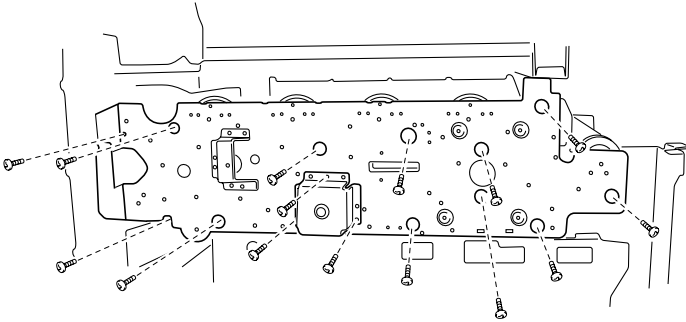

19. Remove the screw from the drum gear sensor and remove the sensor.

Main unit fan removal

1. Remove the left side cover, the solenoid cover, and the rear cover.
2. Remove the two screws from the main unit fan bracket.

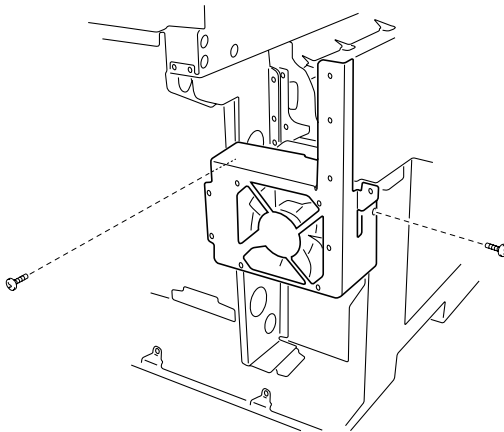

3. Remove the fan.

Motor drive board removal

1. Remove the upper cassette, front cover B, paper feed cover, and the left side cover.
2. Disconnect the five connectors and remove five screws, and two screws from the motor drive board.

Multipurpose feeder paper present sensor removal

1. Open the top unit and remove the upper cassette, front cover, turn guide, multipurpose feeder, right side cover, turn guide, and multipurpose feeder frame.
2. Disconnect the connector and remove the multipurpose feeder paper present sensor.

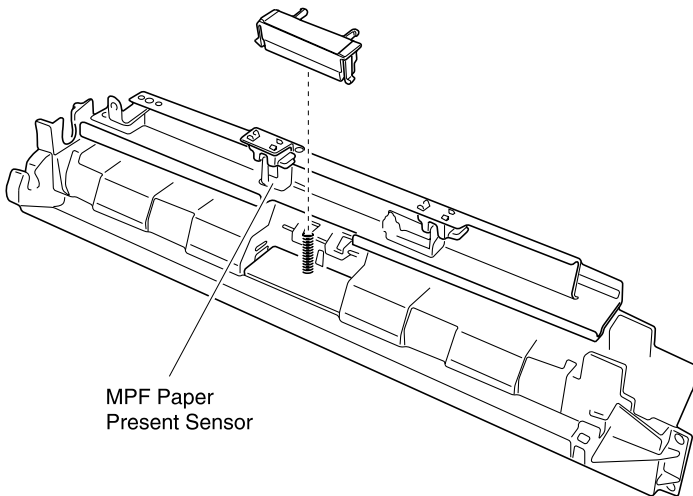

Multipurpose feeder tray removal

1. Open the top unit and remove the front cover, cassette feeder, turn guides and right side cover.

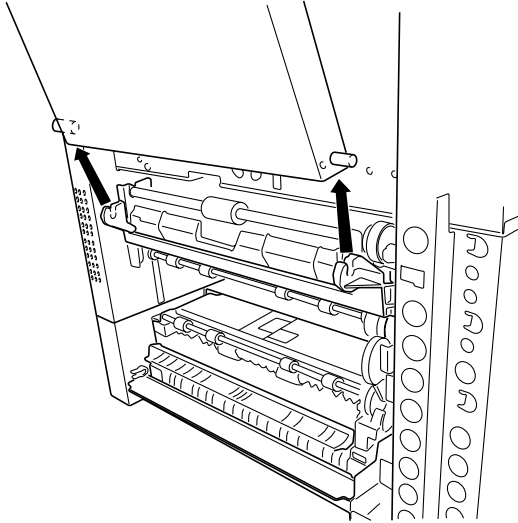

2. Open the multipurpose feeder and slide it toward the magnet in the direction of the arrow, removing it from the printer.

Operator panel removal

1. Open the top unit and remove the toner cartridges and photodeveloper drum units.
2. Remove the operator panel.
3. Remove the two screws from the operator panel case, and remove the case.
4. Remove the cable from the operator panel.

Paper carrying frame removal

1. Open the top unit and remove the upper cassette, front cover, turn guide, multipurpose feeder, right side cover, turn guide, OHP detection sensor (upper), multipurpose feeder frame, back cover, RIP cover, RIP board, RIP box, and electronic box.
2. Remove the four screws from the paper carrying frame.

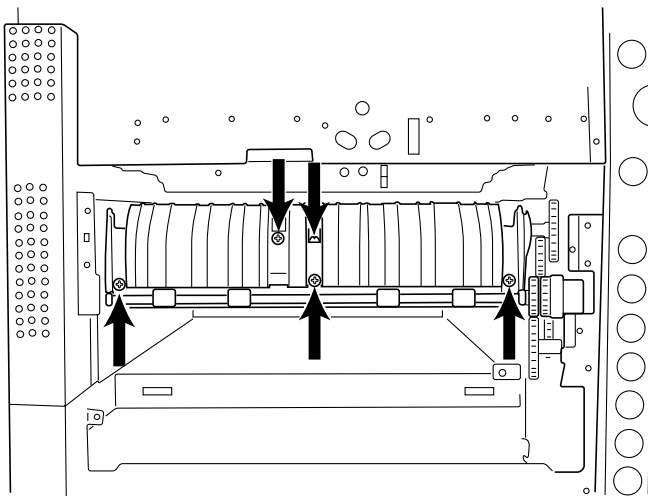

3. Remove the paper carrying frame.

Note: When installing, the clip of the paper carrying clutch should be securely set to the stop, and the shaft of the paper carrying clutch and spring should be securely in contact with each other.

Paper carrying roller removal

1. Open the turn guide.
2. Remove the two screws from the paper carrying roller, and slide the bearing forward.

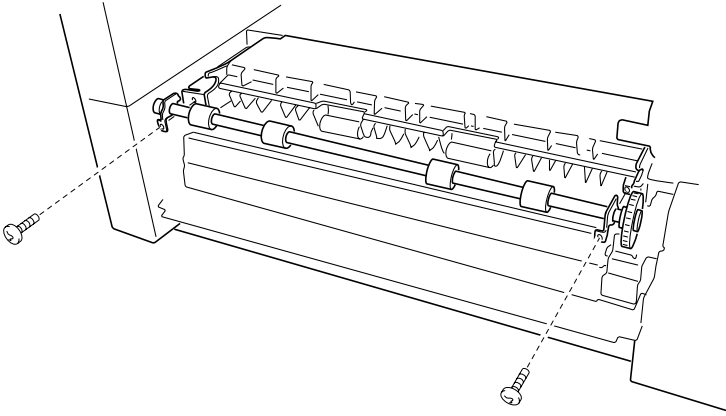

Paper feed frame removal

1. Open the top unit and remove the RIP board cover, RIP board, RIP box, and electronic box. Open the turn guide and paper feed cover and pull out the duplex unit halfway.
2. Remove the belt unit.
3. Disconnect the connector and remove the three screws, and the screw from the paper feed frame.

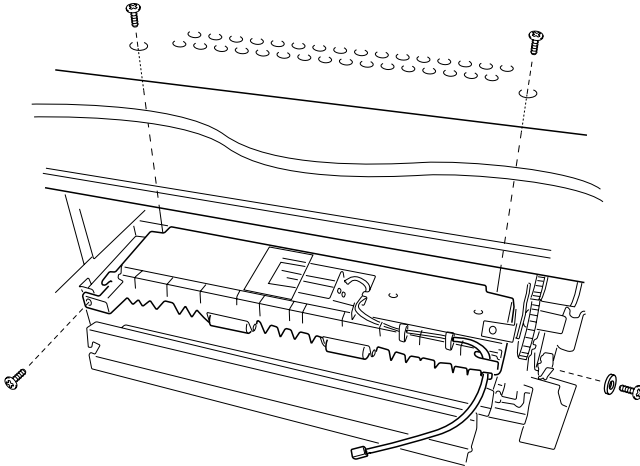

4. Remove the clip from the paper feed roller shaft and remove the gear.
5. Remove the paper feed frame.
6. Disconnect the sensor cable.

Paper feed roller removal

1. Remove the front cover.
2. Remove the manual paper feed tray.
3. Remove the right side cover and turn guide.
4. Remove the upper cassette.
5. Release the clutch until the paper feed roller screws are visible. Turn the paper feed roller, and remove the screws from the roller.

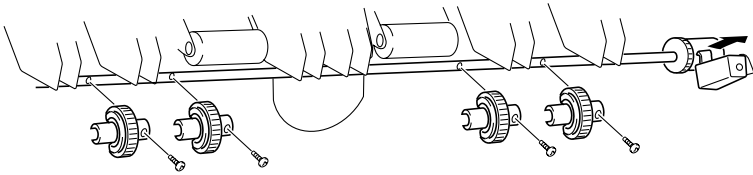

6. Remove the paper feed roller from the shaft.

Note: If the paper feed roller surface is stained with oil or other contaminants, clean it with cloth moistened with alcohol.

Paper present sensor removal

1. Open the paper feed cover and pull out the duplex unit halfway.
2. Unclip the paper present sensor from the mounting.

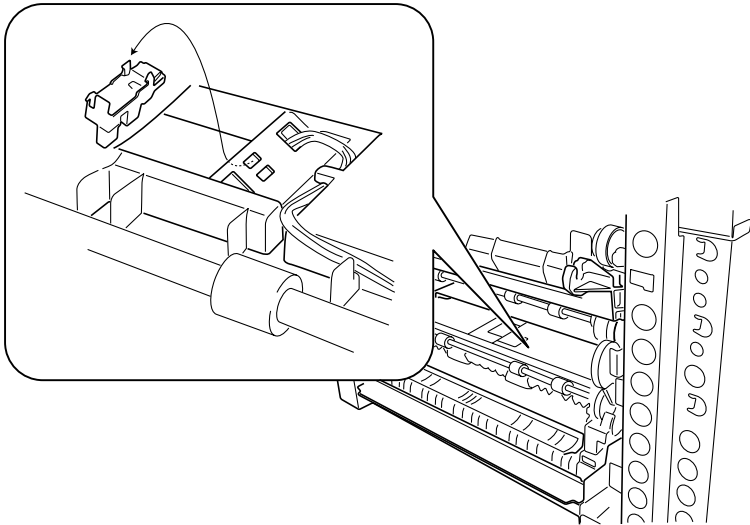

3. Disconnect the connector and remove the sensor.

Paper remaining sensor removal

1. Remove the paper feed frame.
2. Remove the two screws from the paper remaining detection sensor and remove the sensor.

Paper size sensor board assembly removal

1. Open the top unit and remove the RIP cover, RIP board, RIP box, and electronic box. Remove the upper cassette, front cover B, and back cover. Open the turn guide and paper feed cover and remove the duplex unit. Remove the left side cover and power supply A.

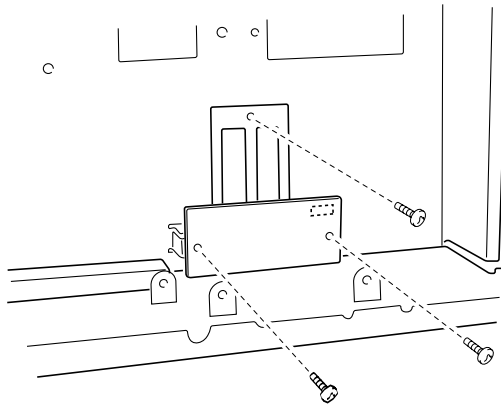

2. Disconnect the connector and remove the two screws from the paper size sensor board, and remove the board.
3. Remove the screw from the size detection lever, and remove the lever.

Power supply 1 removal

1. Unplug the power cord from the printer.
2. Open the top unit and remove the RIP cover, RIP board, RIP box, and electronic box. Remove the cassette, left front cover, and back cover. Remove the left side cover.
3. Remove the insulation sheet connector, yellow ground wire, five screws, two screws with washers, and two screws with spring washers.
4. Disconnect CN01 at the motor driver board, CN106 and CN04 at power supply 2.
5. Remove the power supply.

Note: When installing, incline the ground wire by 45°.

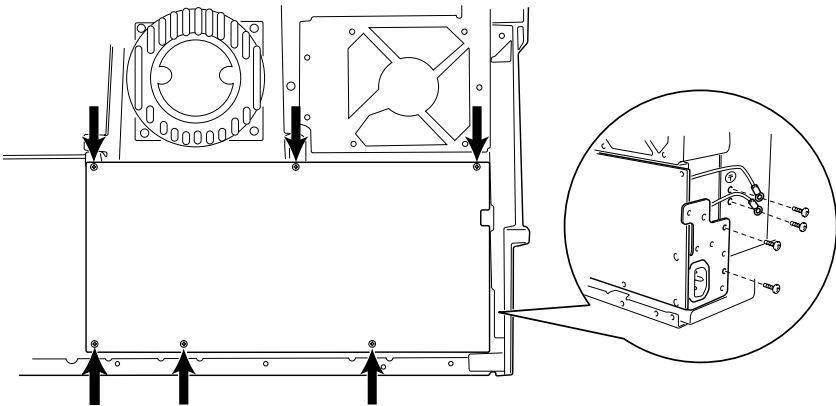

Power supply 2 removal

1. Unplug the power cord from the printer.
2. Open the top unit and remove the RIP cover, RIP board, RIP box, and electronic box.
3. Disconnect the connector and remove the seven screws from power supply 2, and remove the power supply.

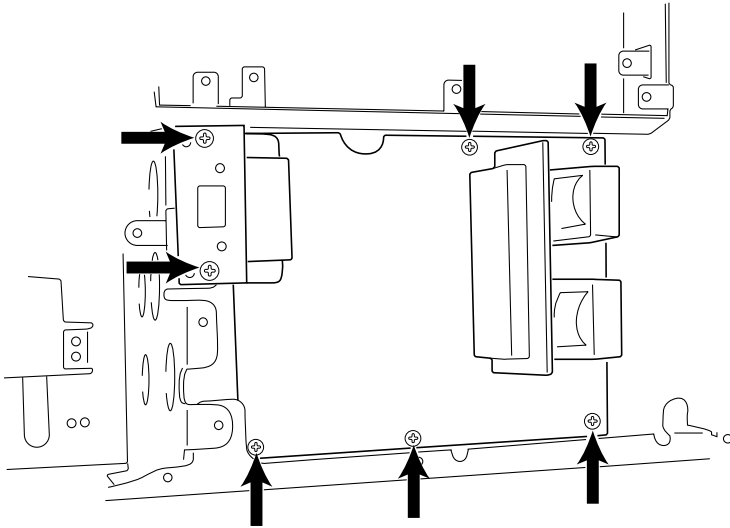

Power switch removal

1. Remove the upper cassette, left front cover, paper feed cover, and left side cover.
2. Unlock the power switch and pull out the power switch.

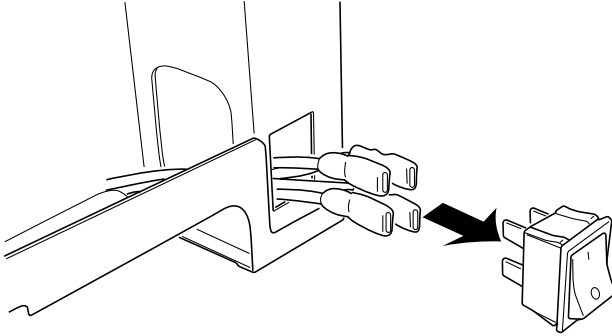

3. Remove each terminal connected to the power switch.

Note: When connecting, be careful to connect the connectors correctly. Insert the insulator cover completely covering the terminal.

Printer controller removal

1. Open the top unit and remove the RIP cover, RIP board, RIP box, and electronic box.
2. Remove the connectors and the eight screws from the printer controller. Pay attention to the location or label the two pin connectors when removing them from the board to avoid re-connection into the wrong location.

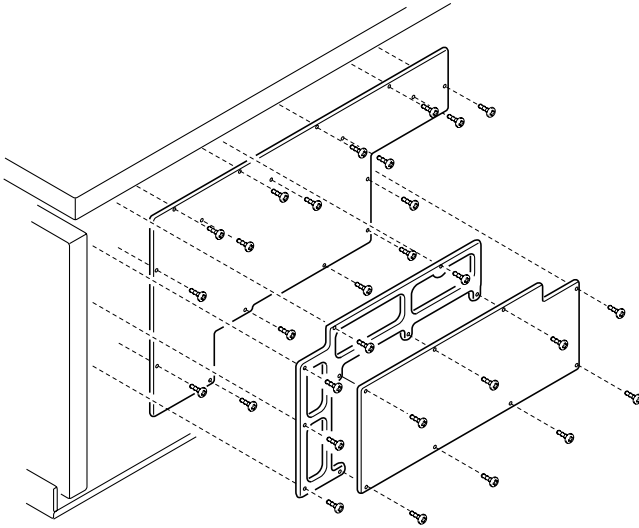

When replacing the board, install the EPROM (U5) of the former board to the new board. Also, when replacing the EPROM, set the light intensity in the diagnostic mode and set the counter and printer alignment.

Printhead controller board removal

For S/N's XX-0XXXX:

1. Remove the top cover.
2. Remove the 20 printhead controller board connectors.
3. Remove the screws from the printhead controller board, and remove the board.

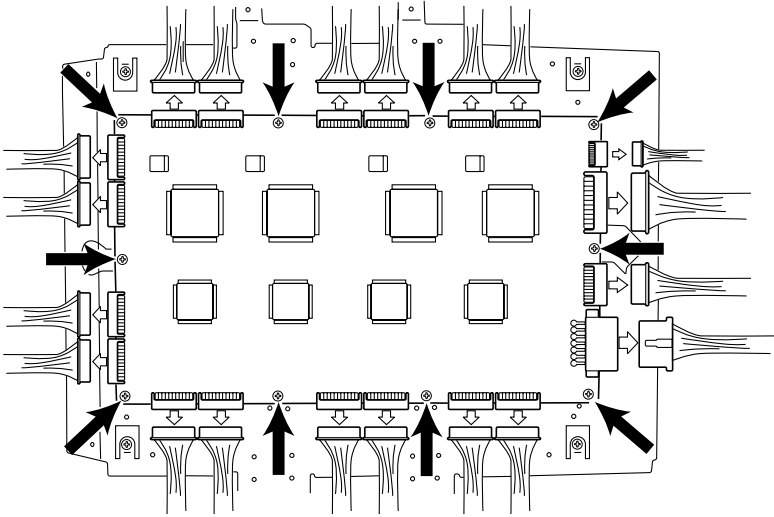

Note: When replacing the board, be sure to return the four EEPROMs on the former board to the same positions on the new board.

For S/N's XX-1XXXX:

1. Remove the top cover.
2. Remove the 12 printhead controller board connectors.
3. Remove the six screws from the printhead controller board and remove the board.

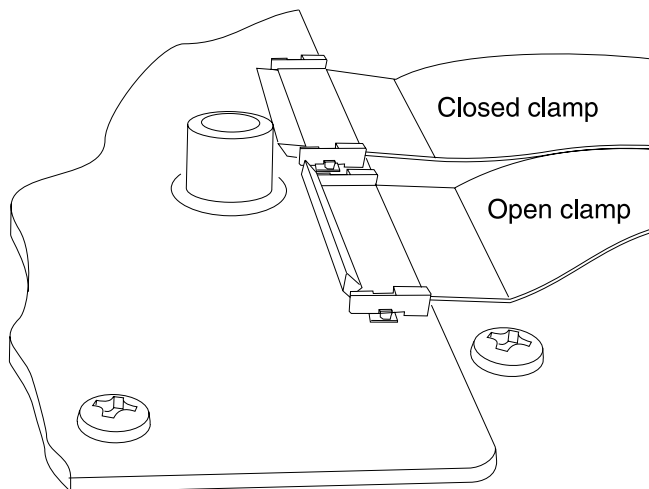
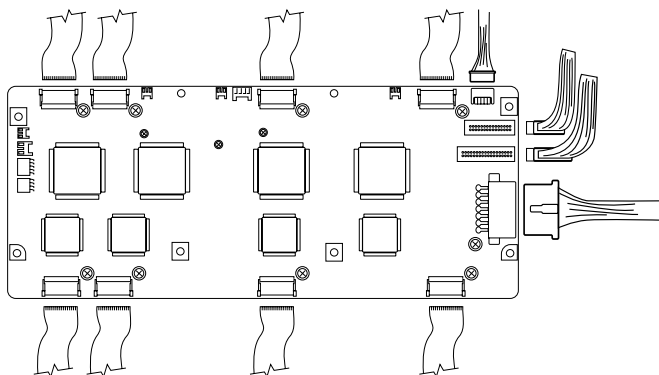

5055-xxx

Note: When replacing the board, be sure to return the four EEPROMs on the former board to the same positions on the new board.

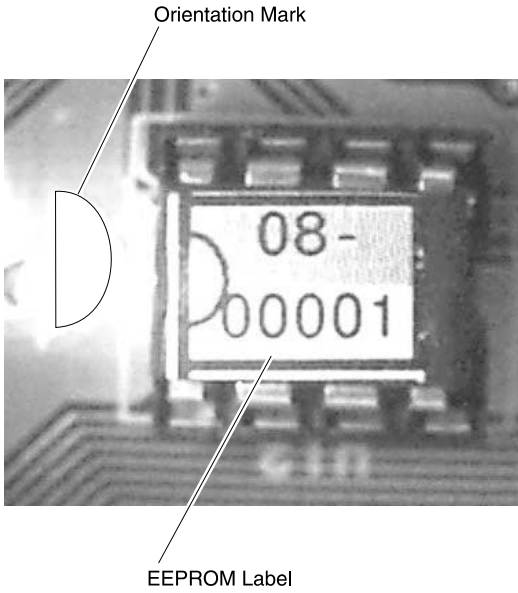

Registration frame

Registration clutch removal

1. Open the top unit, open the turn guide, open the paper feed cover and pull out the duplex unit halfway.
2. Remove the two screws from the registration frame.

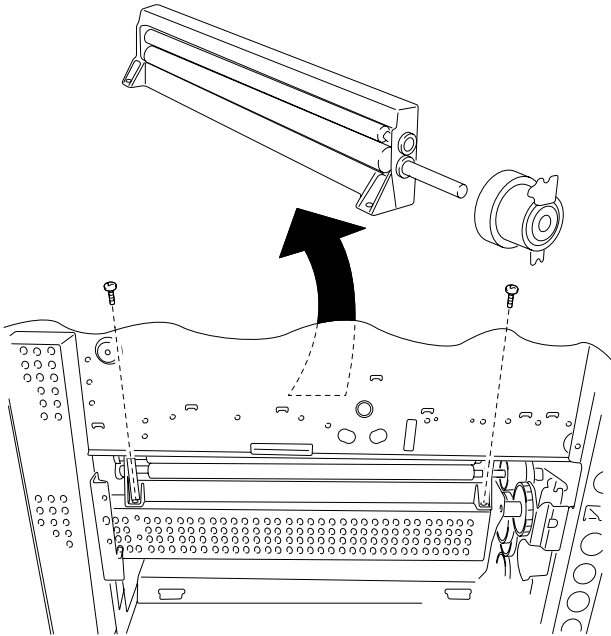

3. Remove the registration clutch.

Note: When installing, set the clip of the registration clutch to the stopper.

Registration sensor removal

1. Open the top unit and remove the upper cassette, front cover, turn guide, multipurpose feeder, right side cover, and multipurpose feeder frame.
2. Disconnect the connector of the registration sensor and remove the sensor.

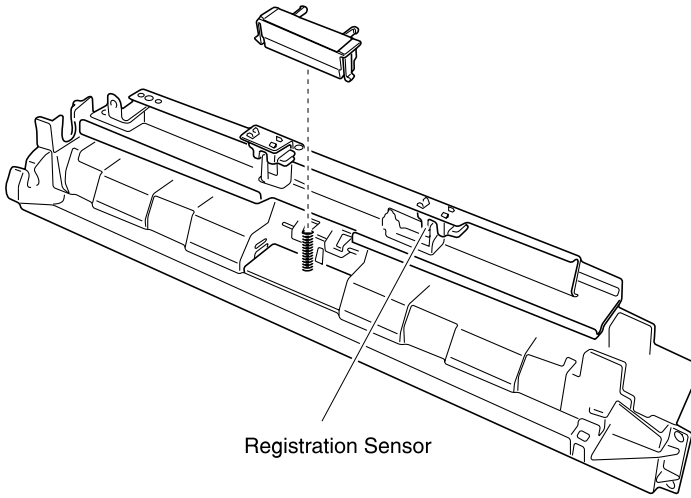

Right slide rail removal

1. Remove the upper cassette.
2. Remove the screw from both left and right slide rails.

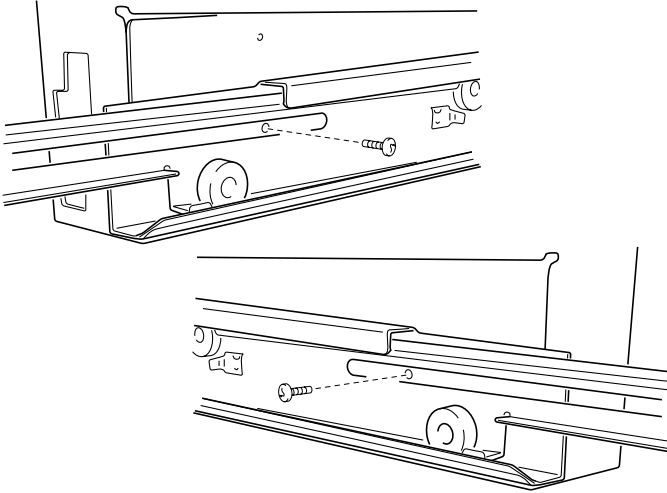

RIP box removal

1. Remove the six screws from the RIP box.

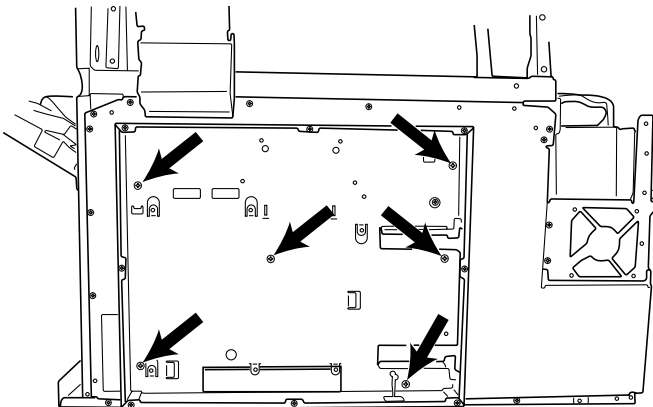

2. Slightly lift and remove the RIP box.

Sensor board removal

1. Remove the transfer belt unit.
2. Remove the four connectors.
3. Remove the three screws from the waste toner full sensor board.

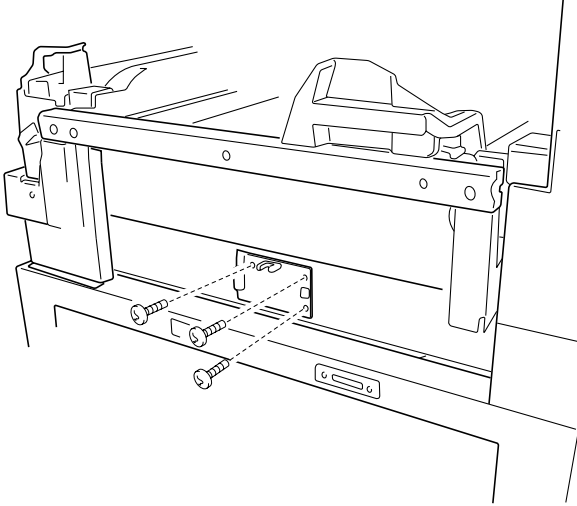

Stay arm removal

1. Open the top unit and remove the face down paper guide assembly.
2. Remove the yellow and black sub frame.
3. Remove the screw from the right stopper, and remove the stopper.

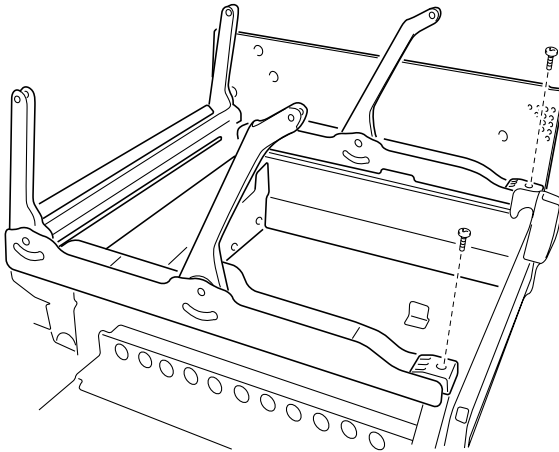

4. Remove the screw from the left stopper, and remove the stopper.
5. Remove the clip from the lock shaft.
6. Remove the 17 screws from the stay arm, and remove the arm.

Sub-frame removal

Important: Read the entire procedure before removal.

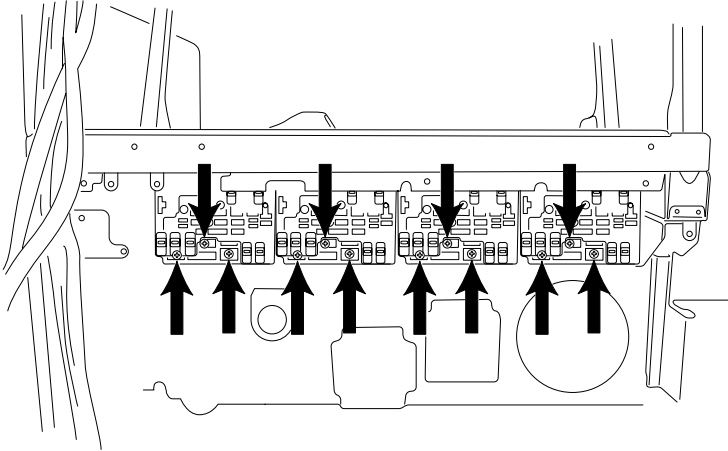

1. Open the top unit, and remove the RIP cover, RIP board, RIP box, electronic box, printer controller, printer controller bracket, and high voltage power supply board.
2. Remove cable ties.
3. Remove the 12 screws from the sub frame.
4. Remove sub frame.

Sub frame F1, sub frame F2 removal

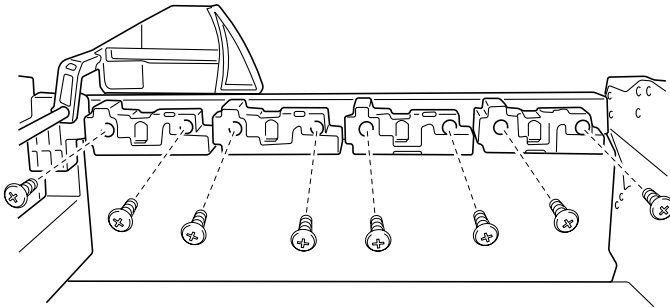

1. Open the top unit
2. Remove the two screws from the sub frames F1 and F2.

Note: Spread a paper or cloth over the belt to protect the belt.
Set the sub frame F to the position of the following colors, depending on the presence of the upper detection buttons.

Magenta	Sub frame F1	Detection button available
Cyan	Sub frame F2	Detection button unavailable
Yellow	Sub frame F1	Detection button unavailable
Black	Sub frame F2	Detection button available

Temperature/humidity sensor removal

Paper feed solenoid removal

1. Open the top unit and remove the RIP cover, RIP board, RIP box, and electronic box.
2. Remove the screw from the temperature/humidity sensor, and remove the sensor.
3. Remove the two screws from the paper feed solenoid bracket and remove the solenoid.
4. Remove the spring from the solenoid plunger arm.

Note: Be sure to use the specific screws during installation. Long screws will damage the solenoid.

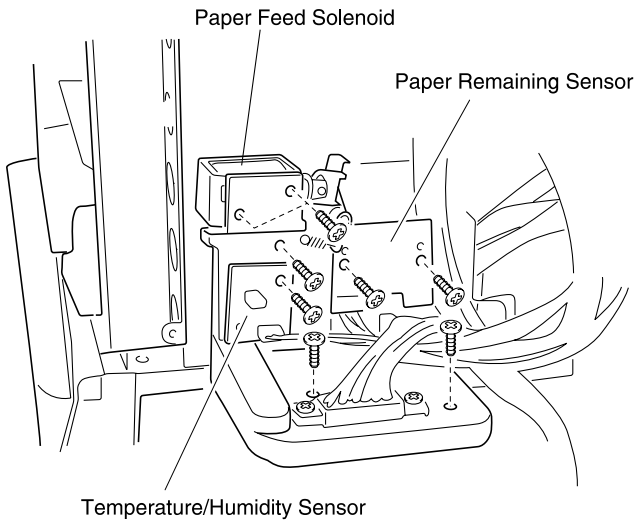

Top unit removal

1. Open the top unit and remove the top cover and face-down guide assembly.
2. Remove the screws and remove the top unit.

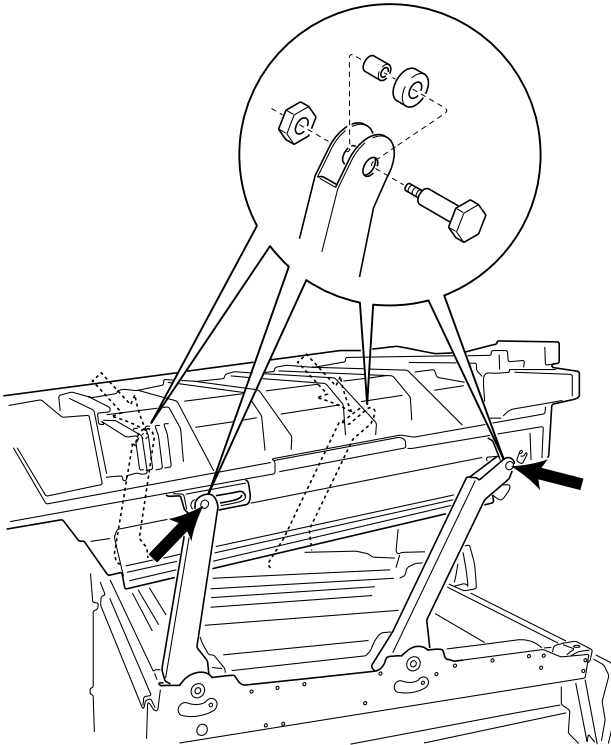

Transfer belt removal

Note: If the transfer belt removal was attempted without using the Supplies Menu to lower the belt and the transfer belt is jammed or stuck, go to **“Alternate method: Transfer belt was partially removed” on page 4-64.**

To replace the transfer belt before the **Life Warning** or **Exhausted** messages appear, open the Supplies Menu on the operator panel and select **Replace Supplies**, select **Belt**, and select **Replace Now**. If the **80 Transfer Belt Life Warning** or **Exhausted** message appears, press **Select** when the **Select = Replace** message appears. The message **Preparing for Maintenance** appears, followed by **Printer Ready for Maintenance**, then **Power Off to Replace Items**.

Note: If the operator panel is inoperable or if you have an unrecoverable error code, go to **“Alternate method: Operator panel is inoperable or unrecoverable error code” on page 4-60.**

1. Turn the printer off along with any optional devices connected to the printer.
2. Open the front cover and top unit.

Warning: Do not touch, drop or place anything on the transfer belt. Touching the surface of the transfer belt or placing items on the belt may cause damage.

3. Loosen the thumbscrews as shown.

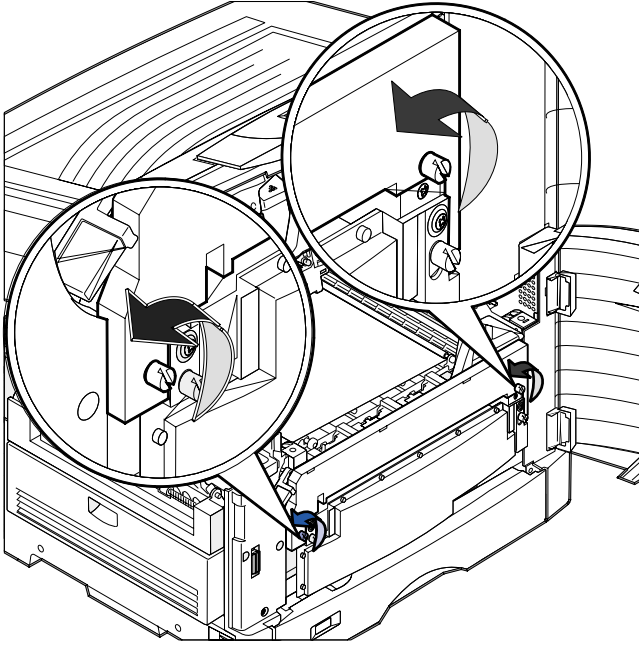

4. Lift and remove the transfer belt cover.

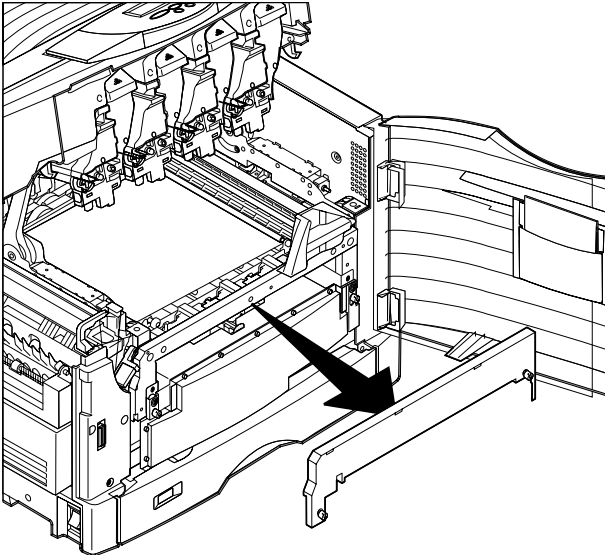

5. Loosen the thumbscrews as shown.

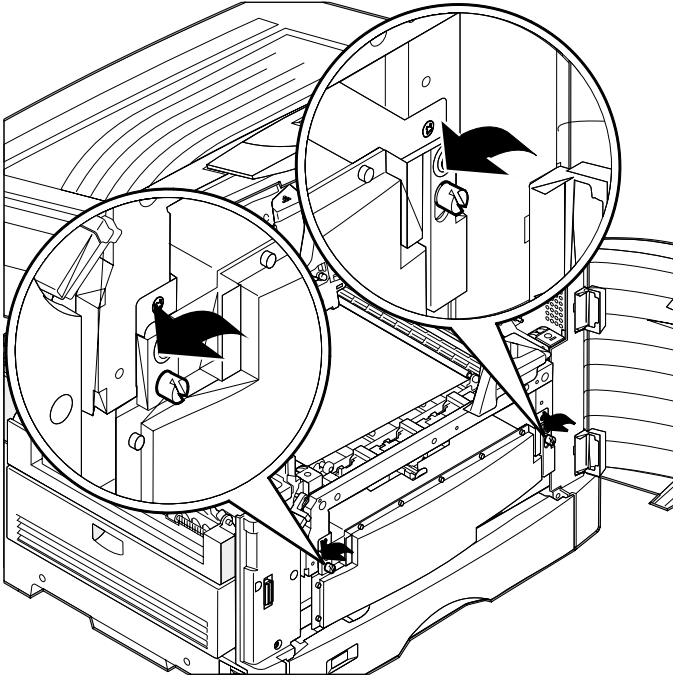

6. Pull the transfer belt out.

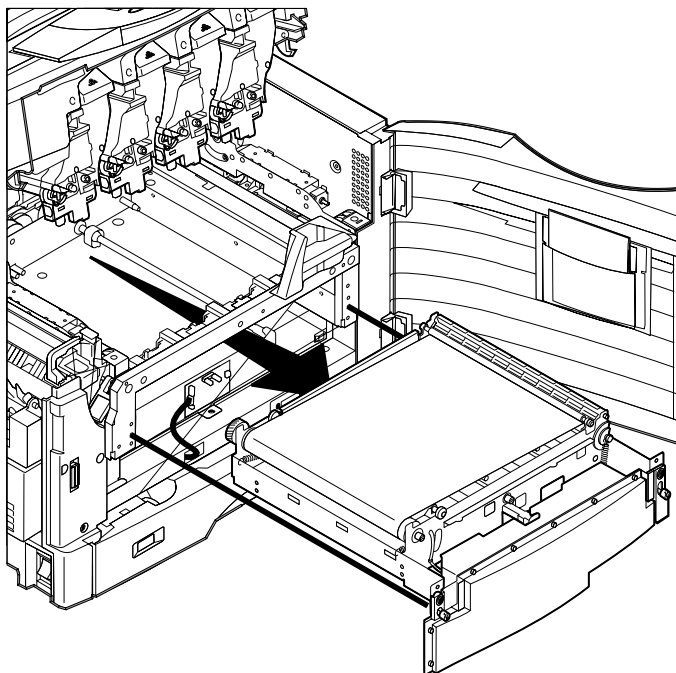

7. After replacing the transfer belt and removing the four shipping spacers, tighten the transfer belt thumbscrews and reinstall the transfer belt cover.
8. Close the top unit and rotate the locking lever to the right, and close the front cover.
9. Turn the printer on.

Note: If the message **Did you Replace Belt?** appears, wait for the message **Select = yes Stop = no** and press **Select**.

If you replaced the belt before the **Life Warning** or **Exhausted** message appeared, open the Supplies Menu on the operator panel and select **Replace Supplies**, then select **Belt**, and select **Replaced**. The message **Printing Alignment Page** appears and the printer prints the alignment page. Follow the instructions on the display to set the alignment values for the new transfer belt.

Alternate method: Operator panel is inoperable or unrecoverable error code

If the operator panel is inoperable or if you have an unrecoverable error code, use this method.

1. Turn the printer off along with any optional devices connected to the printer.
2. Open the front cover and top unit.

Warning: Do not touch, drop or place anything on the transfer belt. Touching the surface of the transfer belt or placing items on the belt may cause damage.

3. Loosen the thumbscrews as shown.

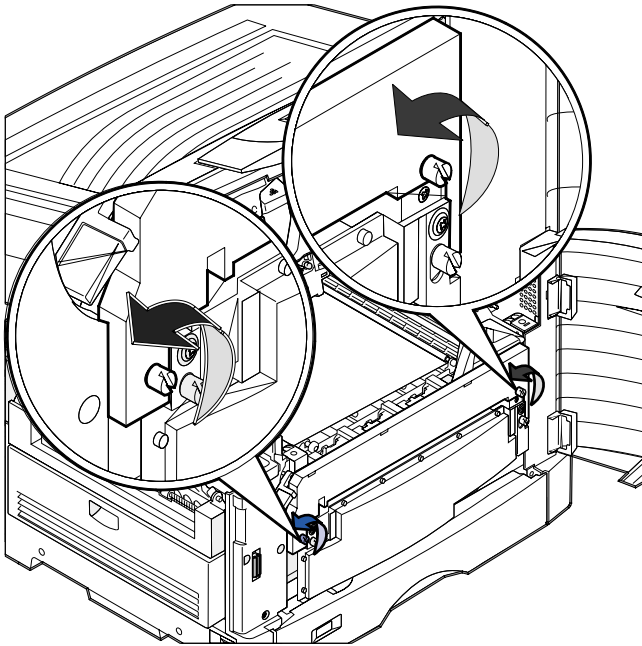

4. Remove the transfer belt cover.

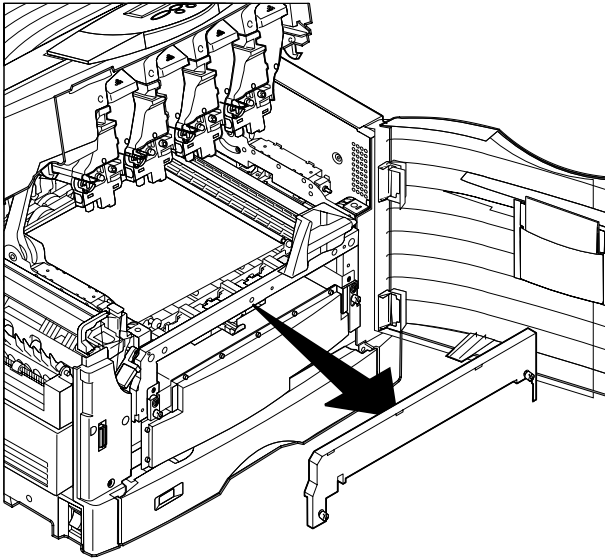

5. Override the front cover interlock switch.
6. Turn the printer on.
7. Look for the belt to lower during power on sequence.
8. Turn the printer off when the belt lowers.

9. Loosen the thumbscrews as shown.

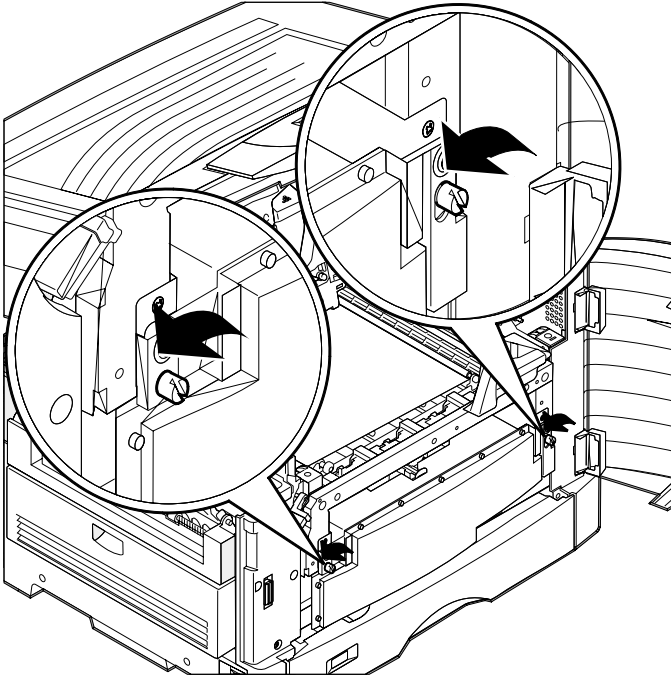

10. Pull the transfer belt out.

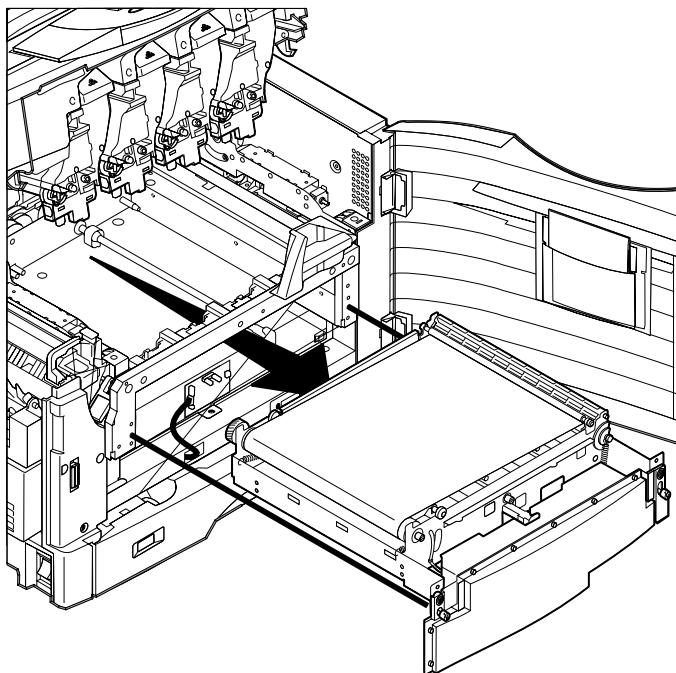

11. After replacing the transfer belt and removing the four shipping spacers, tighten the transfer belt thumbscrews and reinstall the transfer belt cover.
12. Close the top unit and rotate the locking lever to the right, close the front cover.
13. Turn the printer on.

Note: If the message **Did you Replace Belt?** appears, wait for the message **Select = yes Stop = no** and press **Select**.

If you replaced the belt before the **Life Warning** or **Exhausted** message appeared, open the Supplies Menu on the operator panel and select **Replace Supplies**, then select **Belt**, and select **Replaced**. The message **Printing Alignment Page** appears and the printer prints the alignment page. Follow the instructions on the display to set the alignment values for the new transfer belt.

Alternate method: Transfer belt was partially removed

Use this method when the transfer belt removal was attempted without using the Supplies Menu to lower the belt.

1. Turn the printer off.
2. Remove the two thumbscrews on the transfer belt cover.
3. Remove the waste toner bottle.

Note: Be careful not to spill the toner.

4. Look behind the white handle (do not turn the handle) for one of the cams that raises the belt.

A metal follower has fallen off the cam.

5. With a screwdriver, push up on the follower and gently push it back on the transfer belt frame.
6. Seat the transfer belt back into the printer.
7. Reinstall the waste toner bottle.
8. Use the proper removal of the belt by lowering the transfer belt in the Supplies Menu. Go to **“Transfer belt removal” on page 4-56.**

Turn guide cover sensor removal

1. Open the top unit and remove the upper cassette, front cover, multipurpose feeder, right side cover, and turn guide.
2. Remove the two screws from the turn guide sensor, and remove the sensor.

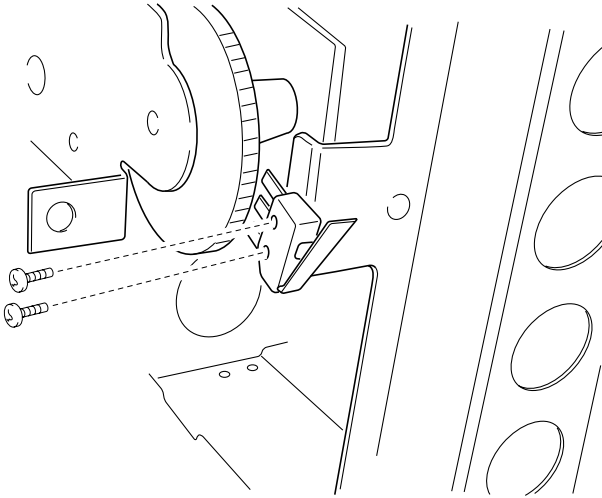

Upper fan removal

1. Open the top unit and remove the toner cartridges and photodeveloper drum units, top cover, and face-down guide assembly.
2. Remove the four screws and the five screws from the upper bracket, and remove the bracket.

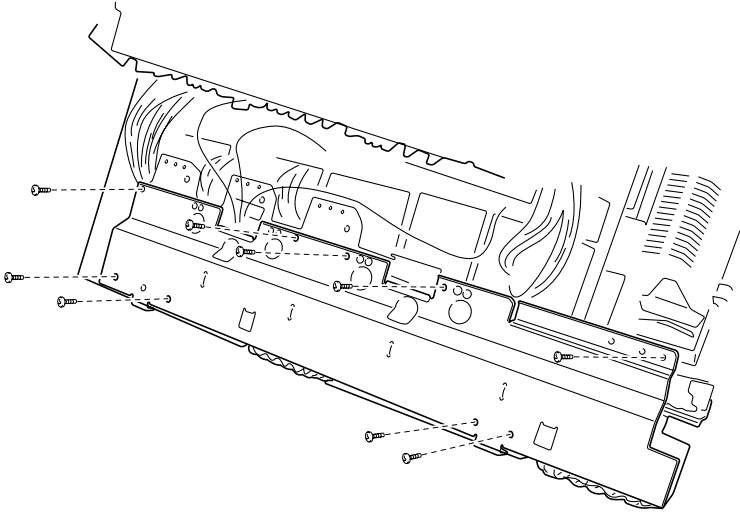

3. Remove the two screws from the left fan, and remove the fan.

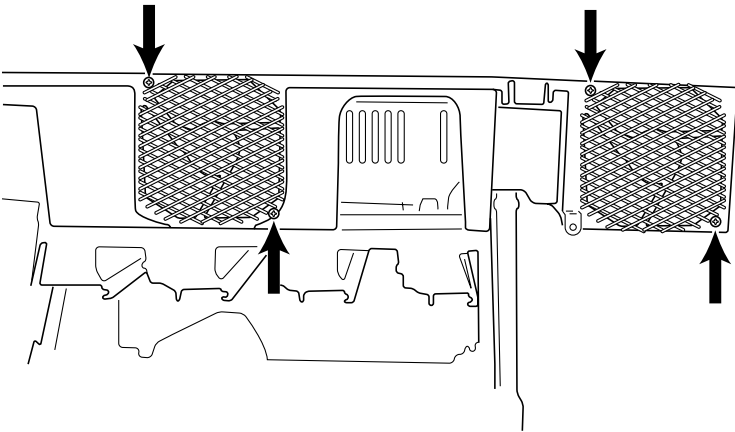

4. Remove the two screws from the right fan, and remove the fan.

Options removals

Expansion paper feeder removal

1. Remove the cassette.
2. Remove the two screws from the front cover, and remove the cover.
3. Remove the two screws from left side cover, and remove the cover.
4. Remove the two screws from right side cover A, and remove the cover.
5. Remove the two screws from right side cover B, and remove the cover.
6. Remove the screw from right side cover C, and remove the cover.
7. Remove the six screws from rear cover, and remove the cover.
8. Remove the turn guide. The cover is hinged in place.

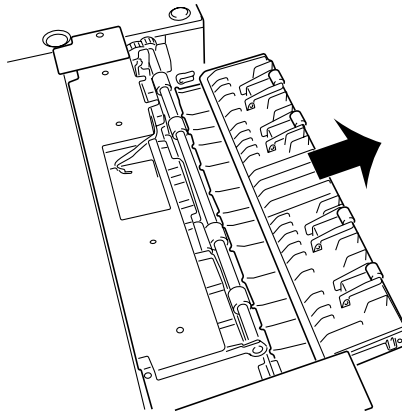

9. Remove the screw from the paper detection cover, and remove the cover.

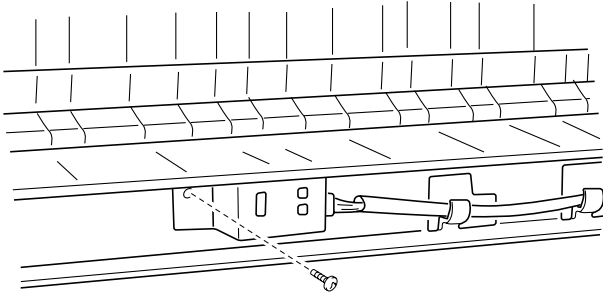

10. Remove the paper detection sensor.

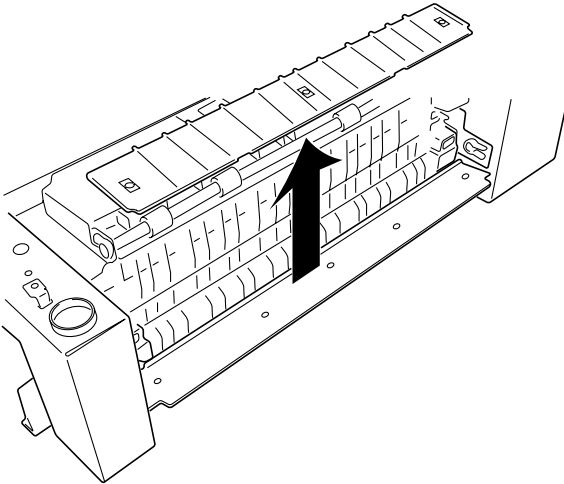

11. Remove the high-capacity feeder guide. The cover is hinged in place.
12. Remove the four screws from the paper feed roller assembly N5 and remove the roller.

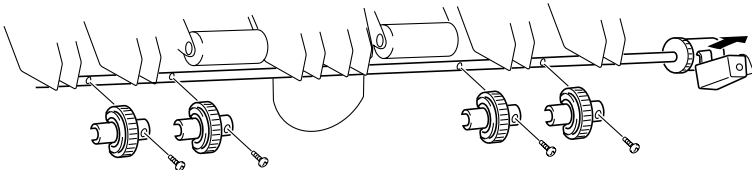

13. Remove the screw from the gear cover, and remove the cover.

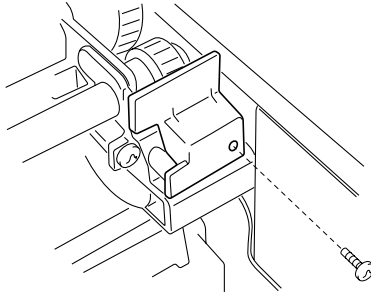

14. Remove the two screws from the paper carrying roller, and remove the roller.

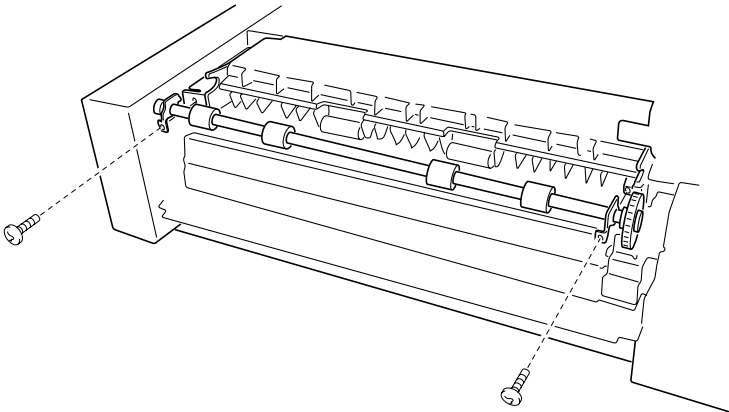

15. Remove the connector and remove the two screws from the drive motor, and remove the motor.

16. Remove the six screws from the drive assembly, and remove the assembly.

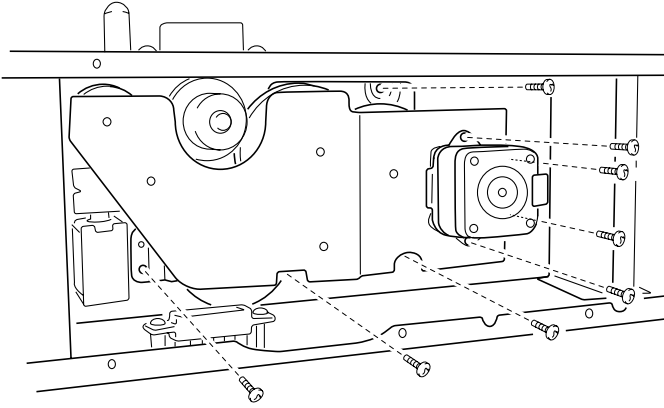

17. Remove the two screws from the paper remaining detection board, and remove the board.
18. Remove the four screws from the solenoid assembly, and remove the assembly.

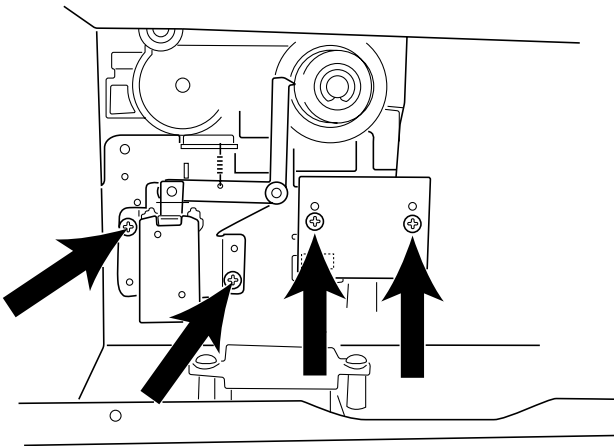

19. Remove the two bearings from the turn guide. The cover is hinged in place.

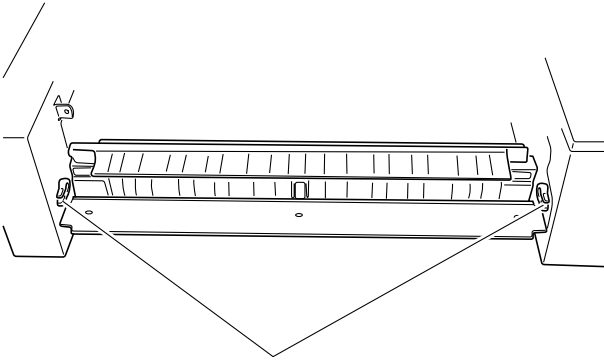

20. Remove the screw from the paper feed frame fuser plate, and remove the plate.

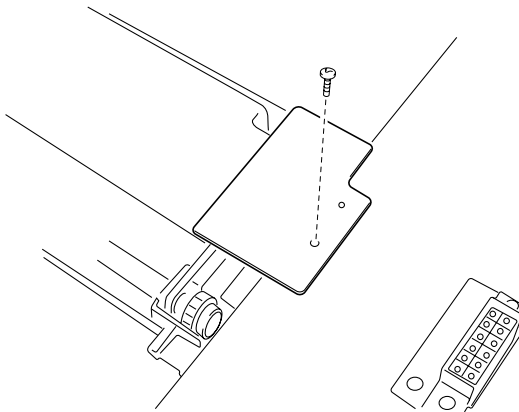

21. Remove the two screws from the fuser frame assembly, and remove the assembly.

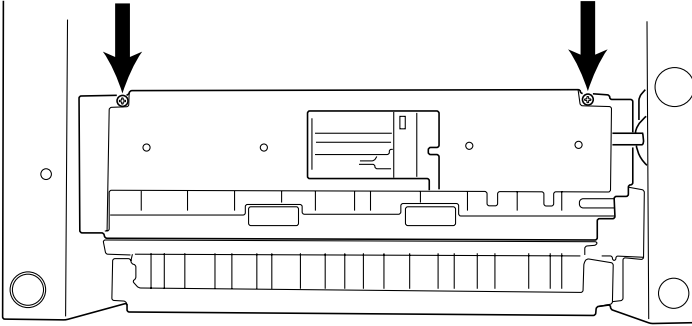

22. Remove the three screws from the cassette guide assembly, and remove the assembly.

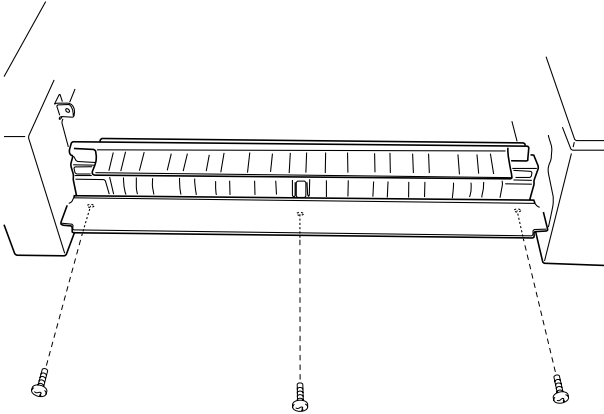

23. Remove the six screws from the second drive board assembly, and remove the assembly.

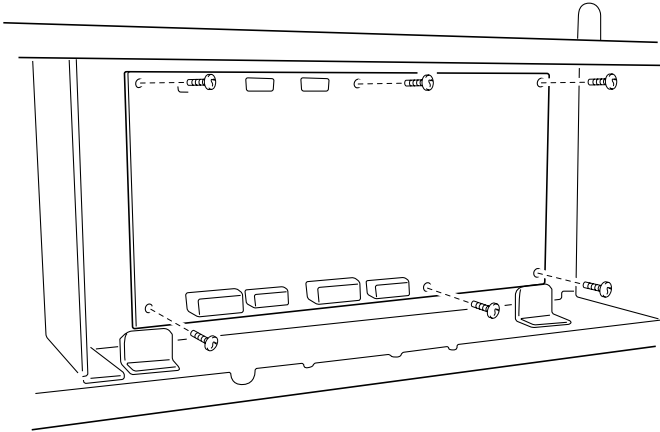

24. Remove the two screws from the paper size detection board, and remove the board.

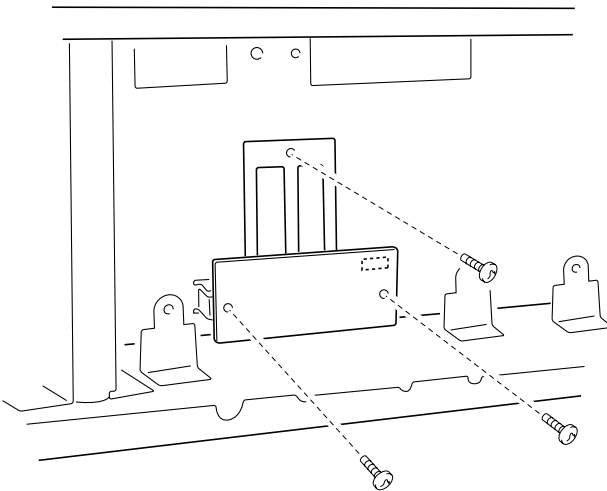

25. Remove the screw from the size detection lever spring, and remove the spring.

26. Remove the two screws from the connector plate, and remove the plate.
27. Remove the two screws from the upper drawer connector (male), and remove the connector.
28. Remove the two screws from the lower drawer connector (female), and remove the connector.

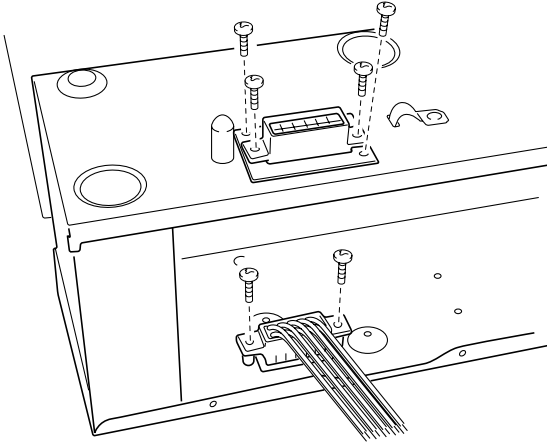

Duplex removals

Duplex unit separation removal

1. Remove the thumbscrews, C-clips, and screws as shown from both sides.

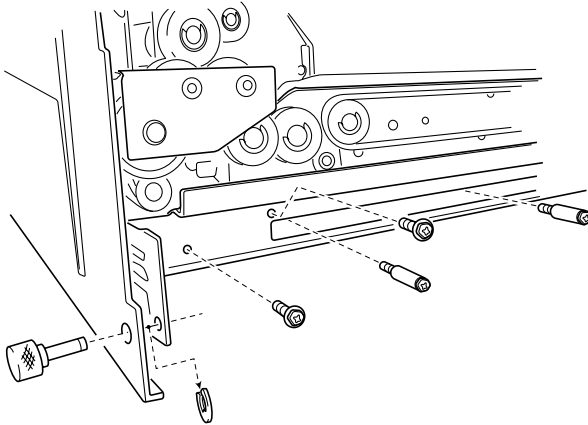

2. Remove the connectors and separate the duplex frame from the duplex unit.

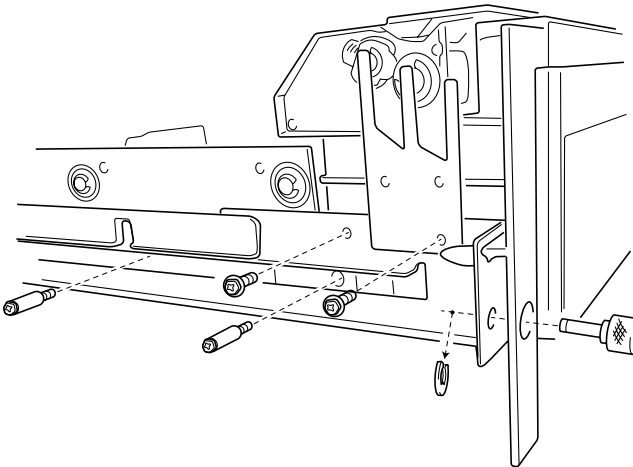

Duplex unit removal

1. Remove the four screws from the interface board, and remove the board.

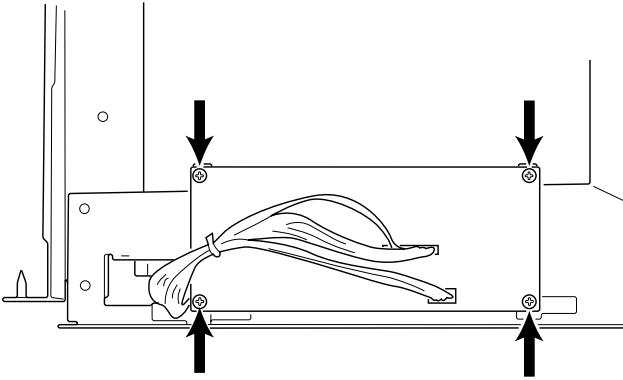

2. Remove the two screws from the duplex connector, and remove the connector.

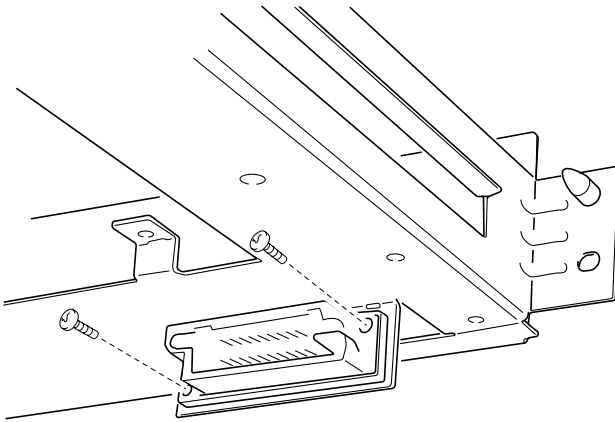

Duplex timing belt removal

1. Remove the three C-clips from the three timing gears and remove the timing belts.
2. Remove the knob screw and remove the timing belt.

Duplex pressure roller and solenoid removal

1. Remove the two screws securing the pressure roller solenoid assembly.

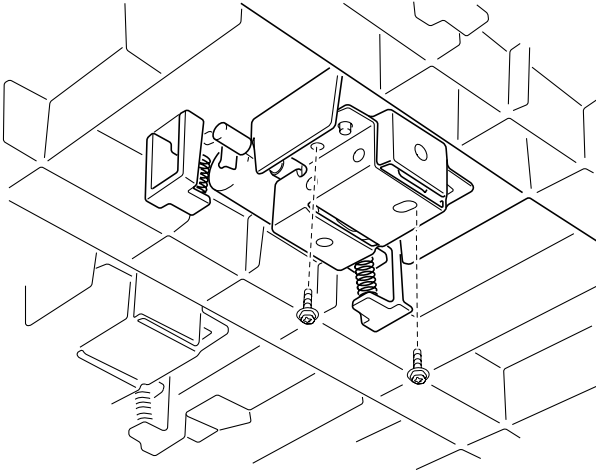

Duplex feed roller and solenoid removal

1. Remove the two screws securing the feed roll solenoid assembly.

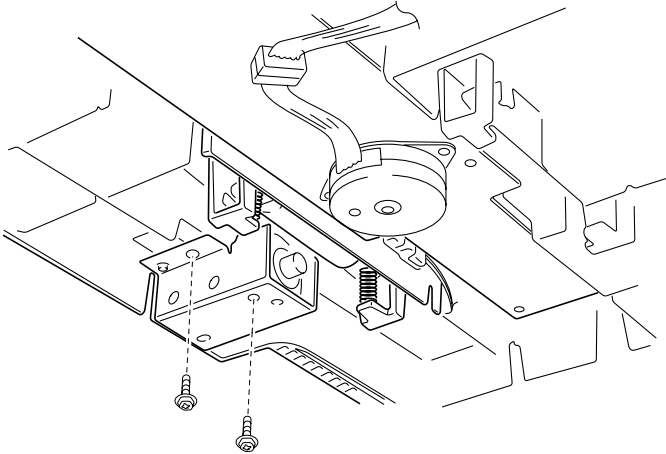

2. Remove the pressure roller and springs.
3. Remove the feed roller and springs.

Duplex side fence motor assembly/side fence removal

1. Remove the three screws and remove the side fence motor assembly.

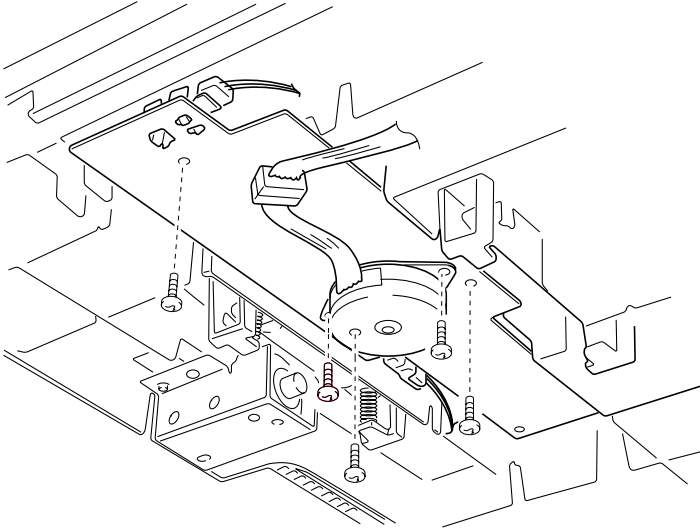

2. Remove the front and rear side fences.

Note: When installing, spread the front and rear side fences to the sides and install.

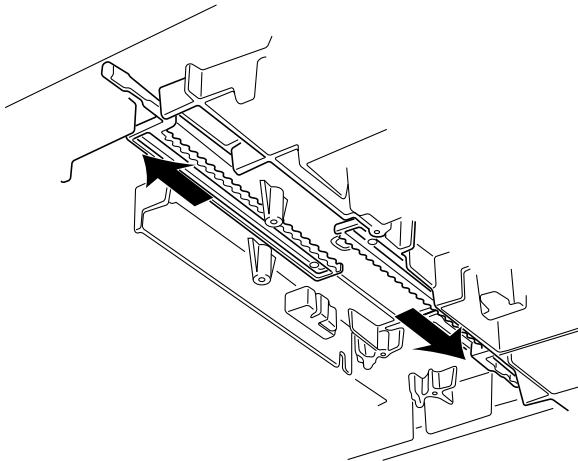

Duplex paper carrying motor removal

1. Remove the gear cover.
2. Remove the screws from the duplex paper carrying motor and remove the motor.

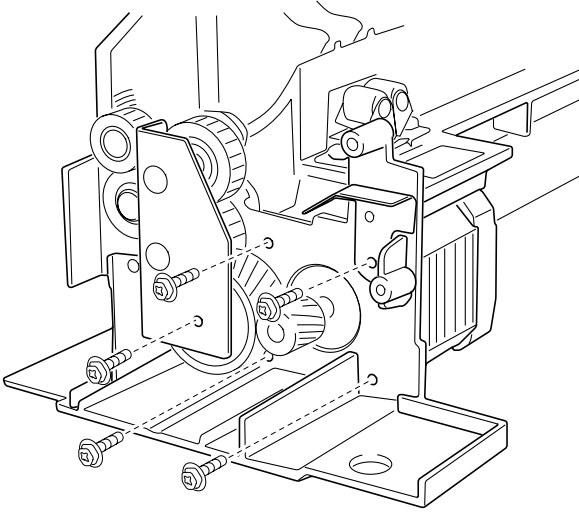

High-capacity feeder (HCF) removals

HCF covers removal

1. Remove the two screws from the drive cover, and remove the cover.
2. Remove the front cover.
3. Remove the two screws from the right cover, and remove the cover.
4. Remove the top cover.
5. Remove the rear cover.
6. Remove the four screws from the transfer cover, and remove the cover.

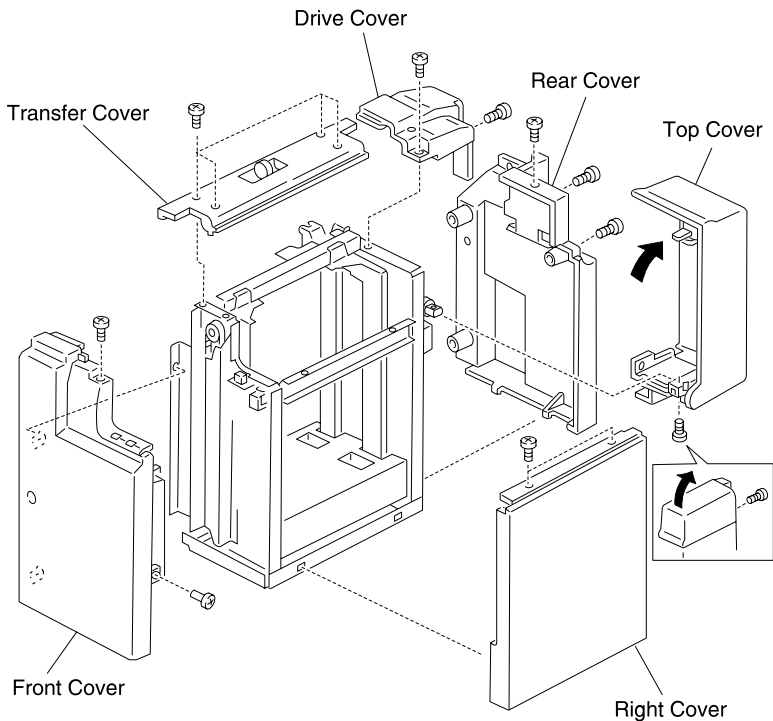

HCF call roller, paper feed roller, reverse roller removal

1. Open the top cover on the tray.
2. Remove the two screws from the transfer cover, and remove the cover.
3. Remove the retaining rings on the rollers, and remove the rollers.

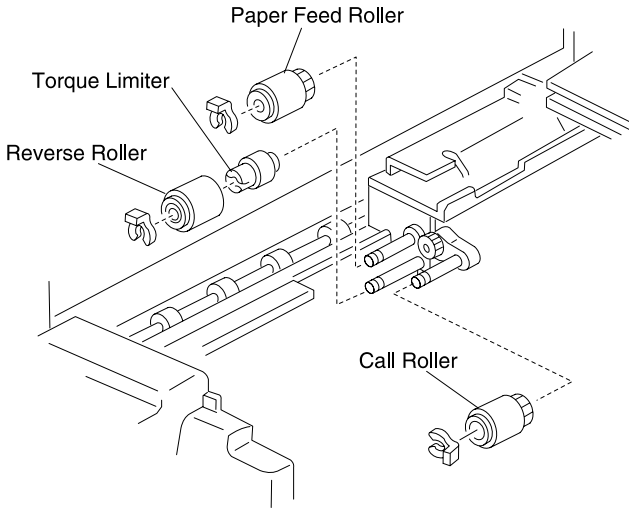

HCF pickup solenoid removal

1. Remove the four screws from the transfer cover, and remove the cover.
2. Remove the two screws from the drive cover, and remove the cover.
3. Remove the screw from the clamp plate, and remove the plate.
4. Remove the connector and the two screws from the pickup solenoid, and remove the solenoid.

Clamp Plate (Clamp; Paper Feed; Front and Rear)

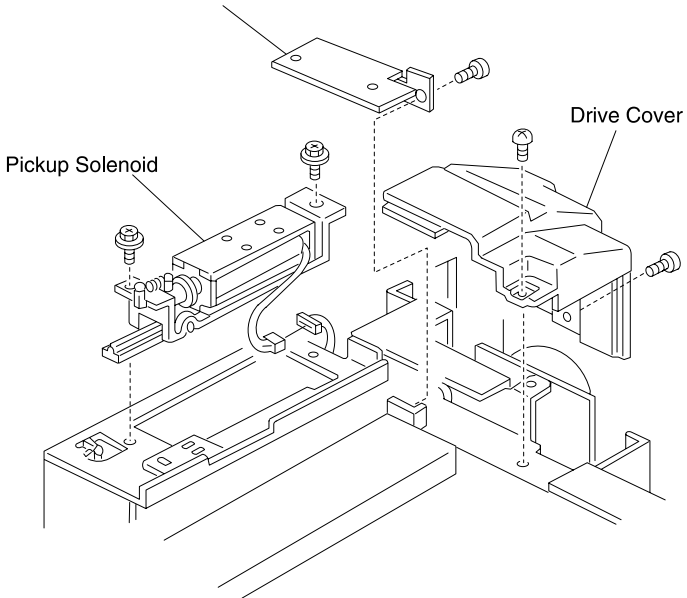

HCF paper end sensor removal

HCF paper size sensors (1, 2) removal

1. Cover the paper level sensor with your hand and press the down button. The tray moves down. Lower the tray until the down sensor turns on.
2. Remove the front cover and transfer cover.
3. Remove the two screws on the front and rear sides of the side fence.
4. Mark the locking position of the side fence locking stay.
5. Remove the two screws on the side fence locking stay.
6. Remove the screw and connector from paper end sensor, and remove the sensor.
7. Remove the screw and connector from the clamp plane and remove the paper size sensors 1 and 2.

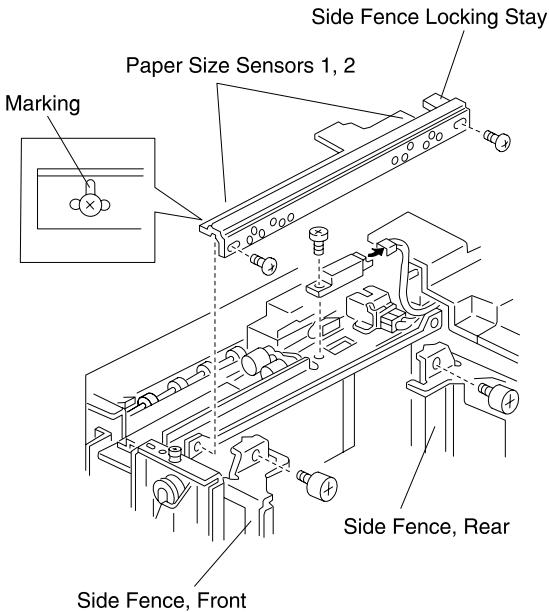

Notes:

- To prevent damage to the stay, hold the stay when removing the sensors.
- Be sure the side registration is not shifted, which may occur with the dismounting and mounting of the locking stay. If it is shifted, relocate the stay toward the front or rear to adjust.

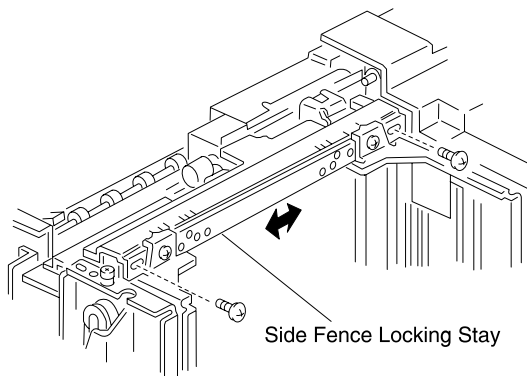
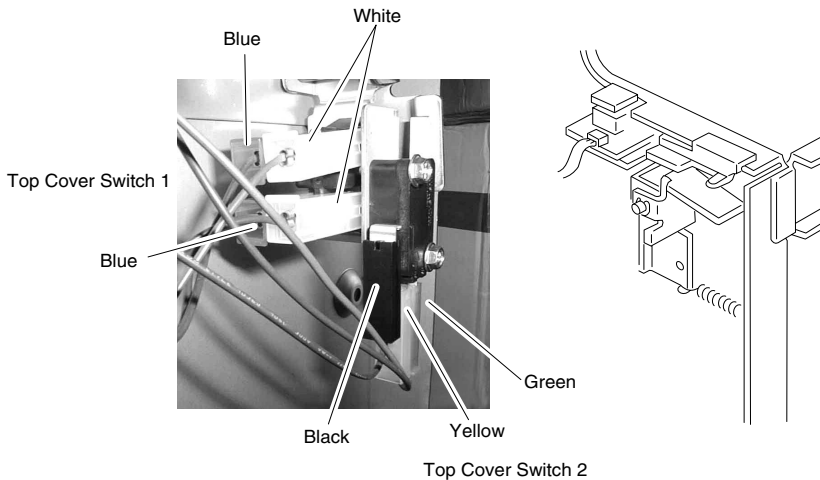
**8. Remove the top cover switches.**

HCF tray motor removal

1. Remove the rear cover and the drive cover.
2. Remove the two screws of the tray motor, and remove the motor.

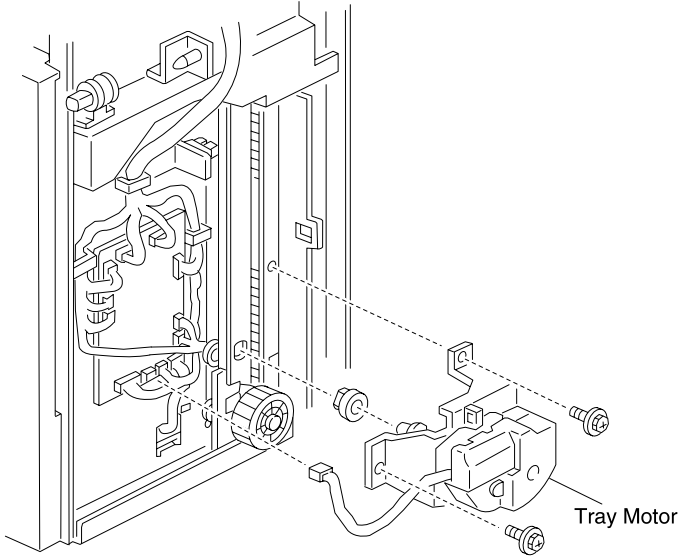

HCF paper level sensor removal

1. Remove the four screws from the transfer cover, and remove the cover.
2. Remove the two screws from the sensor, and remove the cover.
3. Remove the connector and screw from paper level sensor, and remove the sensor.

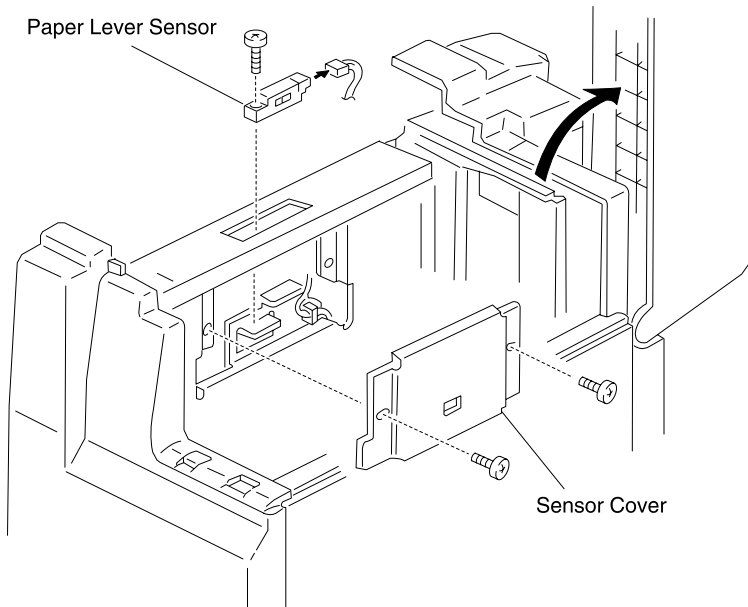

HCF power supply removal

1. Move the paper tray upward.
2. Disconnect the power cord.
3. Remove the front cover.
4. Remove the two screws from the power supply cover, and remove the cover.
5. Remove the four screws from the power supply unit and remove the unit.
6. Remove the two screws from the DC-DC converter, and remove the converter.

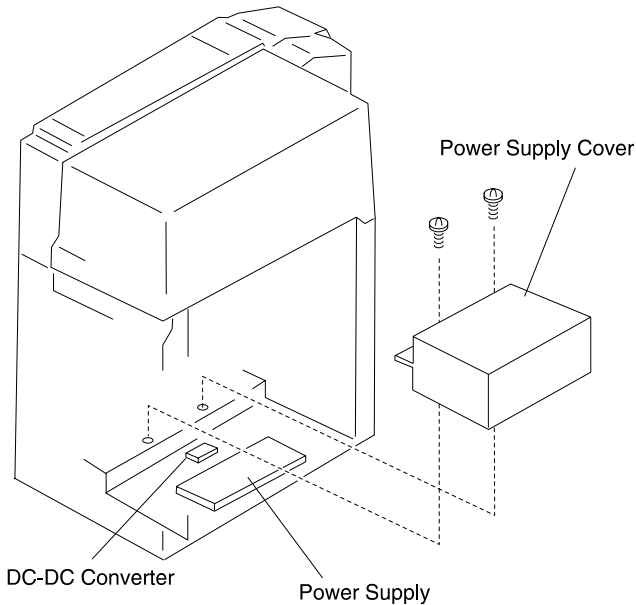

Finisher removals

External covers removals

1. Remove the finisher trays.

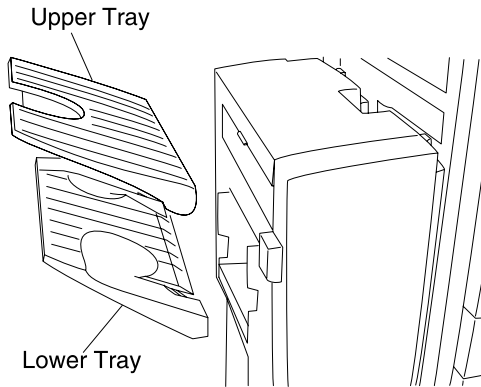

2. Remove the two screws from the front cover and remove the cover.
3. Remove the two screws of the rear cover and remove the cover.

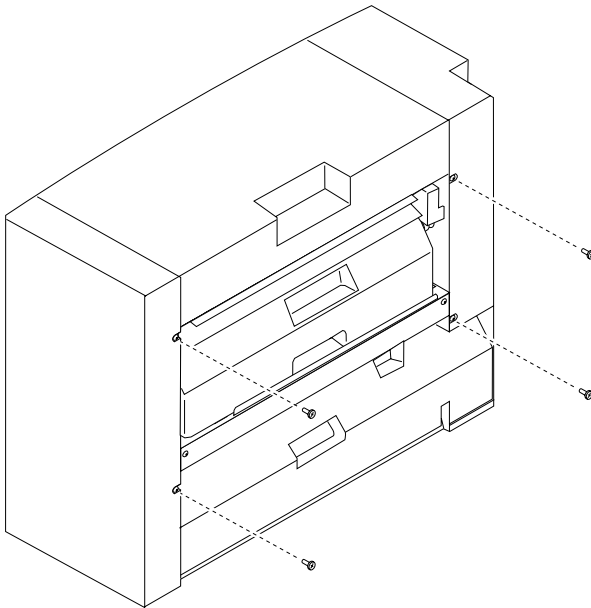

4. Remove the two screws from the top cover and remove the cover.

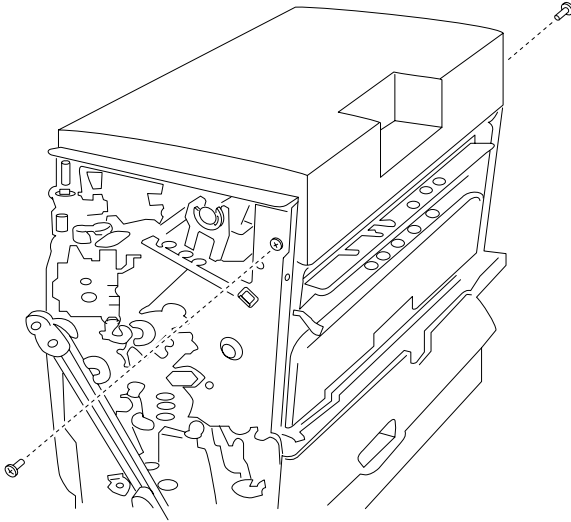

Finisher control board removal

1. Remove the external covers.
2. Disconnect all of the associated connectors.
3. Remove the four finisher control board mounting screws and remove the board.

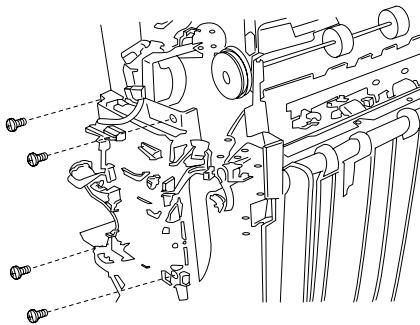

Elevator motor removal

1. Disconnect the elevator motor connector.
2. Remove the two elevator motor bracket screws from the bracket.
3. Remove the elevator motor assembly.

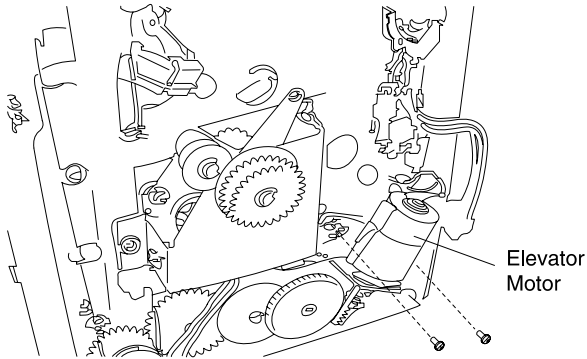

Feed motor assembly removal

1. Remove the finisher control board mounting bracket.
2. Loosen the tension bracket mounting screw.

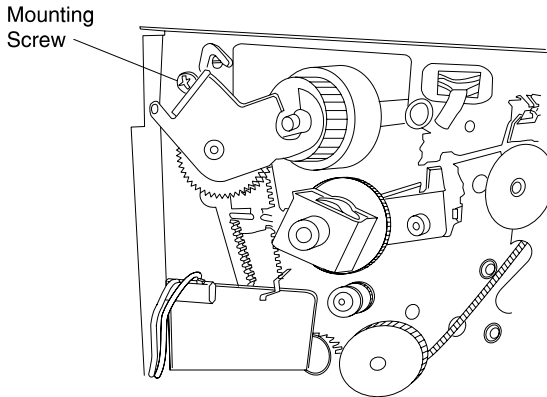

3. Disconnect the feed motor connector.
4. Remove the three screws and connector from the feed motor mounting bracket and remove the feed motor assembly.
5. Remove the feed motor pulley.

Hole punch removal

1. Remove the external covers.
2. Remove the hole punch unit cables.
3. Remove the tension spring.
4. Remove the screw and E-ring from the tension bracket and remove the bracket.

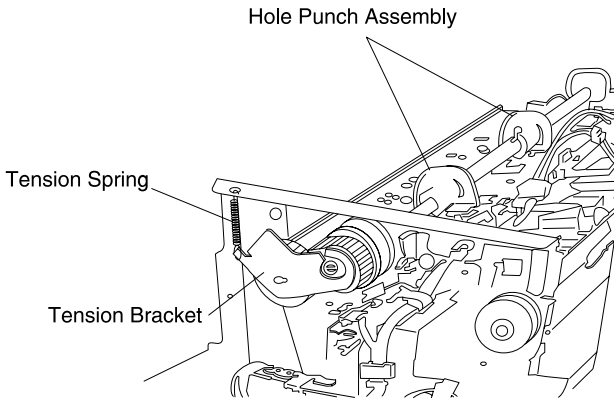

Note: When installing the tension bracket, use the left side screw hole for the three hole punch unit and the right side screw hole for the four hole punch unit.

5. Remove the two hole punch unit screws and remove the unit.

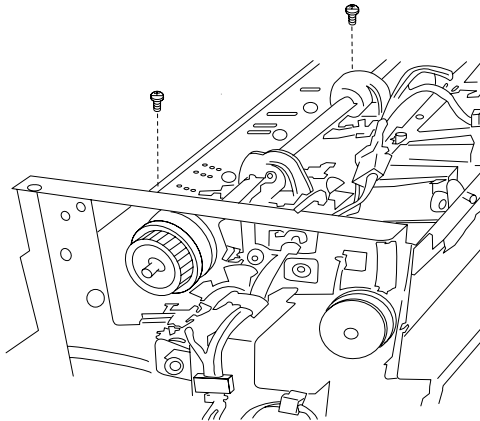

Inverter paper exit discharge brush removal

1. Remove the external covers.
2. Remove the finisher control board.
3. Remove the upper left panel.
4. Remove the two discharge brush screws and remove the brush.

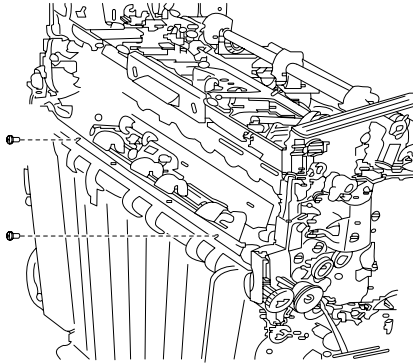

Inverter paper exit roller removal

1. Remove the front and rear external covers.
2. Remove the four lower left panel screws and remove the panel.

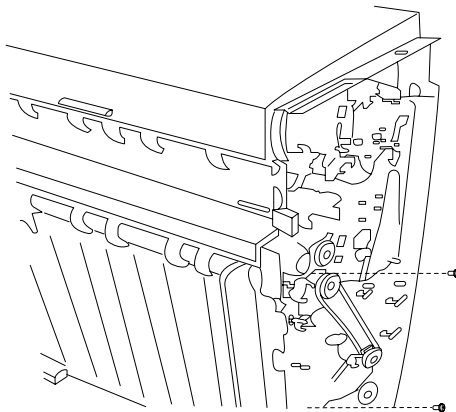

3. Disconnect the harness connect from the lower left panel.

4. Remove the inverter paper exit roller bushing.

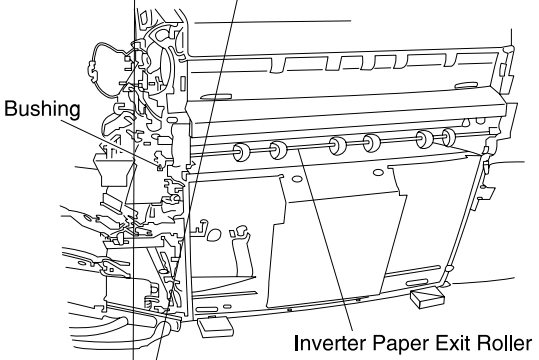

5. Remove the inverter idle gear.
6. Remove the inverter drive gear and bushing.

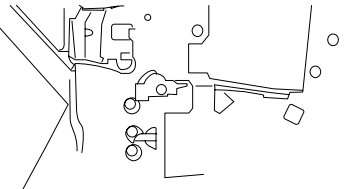

7. Remove the inverter paper exit roller.

Jogging unit removal

1. Remove the dust box.
2. Remove the two screws and remove the cover.

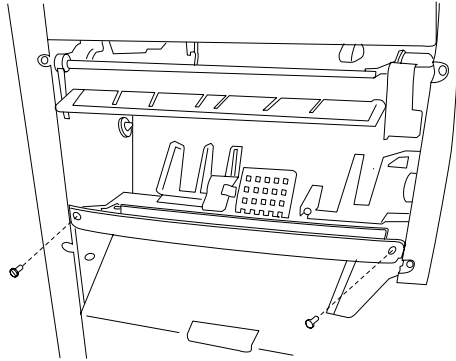

3. Disconnect the jogging motor connector.
4. Disconnect the jogging home position sensor connector.

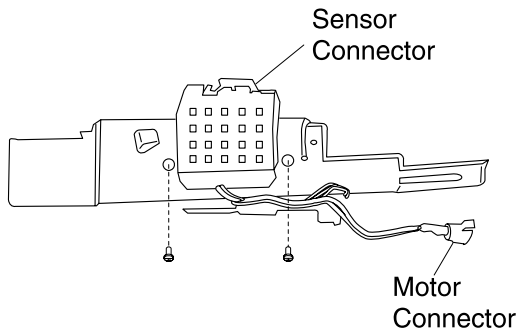

5. Remove the jogging unit.

Path select gate removal

1. Remove the external covers.
2. Remove the two screws from the top cover and remove the cover.
3. Remove the gate solenoid with mounting bracket.
4. Remove the straight paper exit sensor connector.
5. Remove the upper guide plate for the straight paper exit.
6. Remove the two screws and two springs for the upper guide plate.

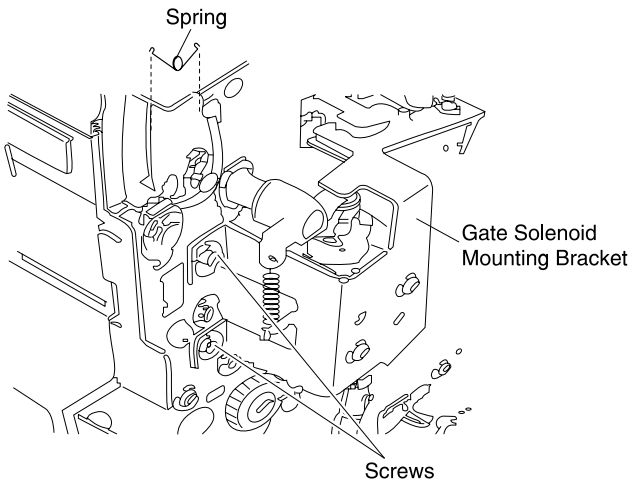

7. Remove the path select gate.

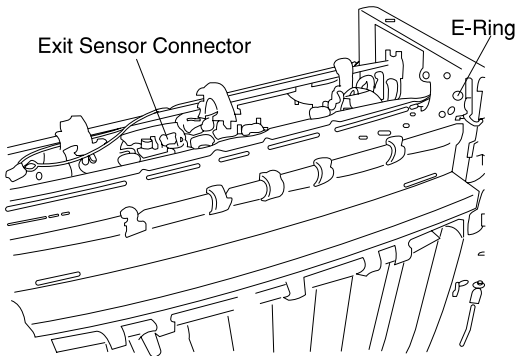

Note: Adjust the solenoid bracket mounting position so that the gate arm is contacting the solenoid.

Patting roller removal

1. Remove the front and rear covers.
2. Remove the finisher control board mounting bracket.

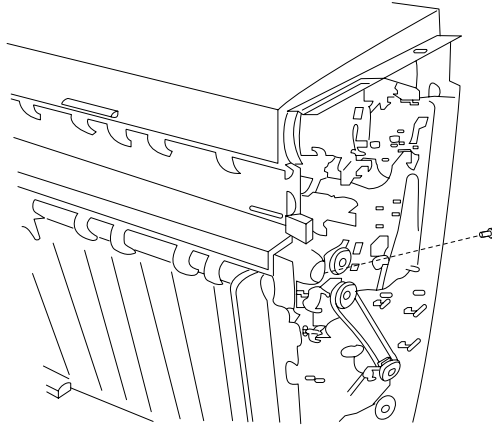

3. Remove the two screws from the upper left panel and remove the panel.

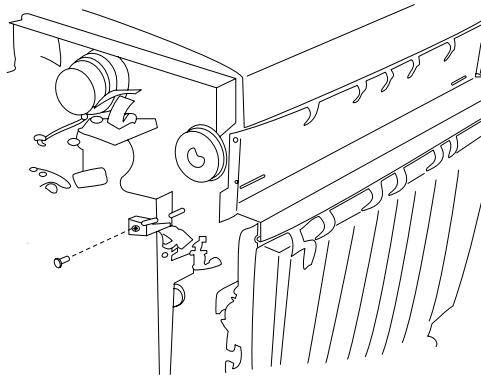

4. Disconnect the sensor connector.
5. Remove the sensor harness from the harness clamp.

6. Remove the four upper guide plate screws from the inverter paper exit and remove the plate.

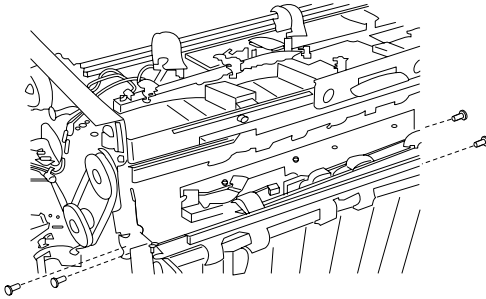

7. Remove the four screws from the inverter guide plate and remove the plate.
8. Remove the tension springs. Use the upper hole when installing the spring.

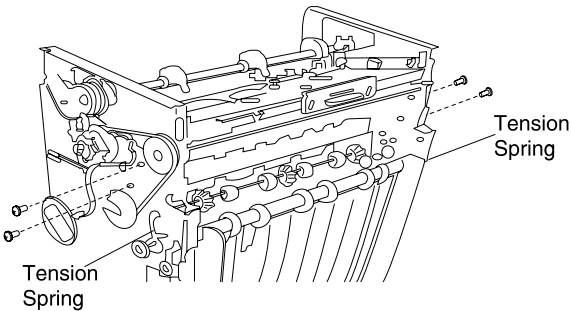

9. Remove the gear and bushing.

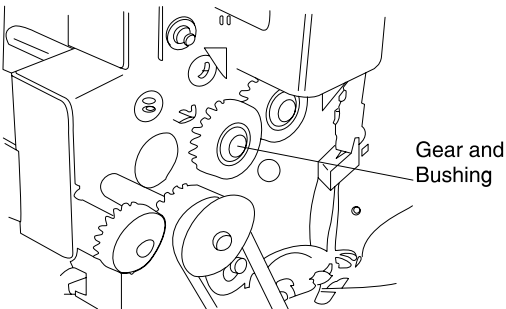

10. Remove the patting roller.

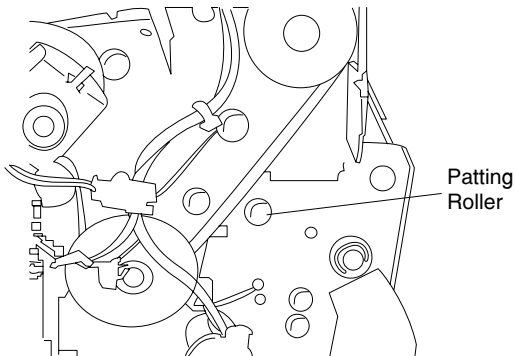

Power supply removal

1. Unplug the power cord from the printer.
2. Remove the external covers.
3. Remove the lower left panel.
4. Remove the cable connector for the left panel.
5. Remove the four lower guide support plate screws and remove the plate.

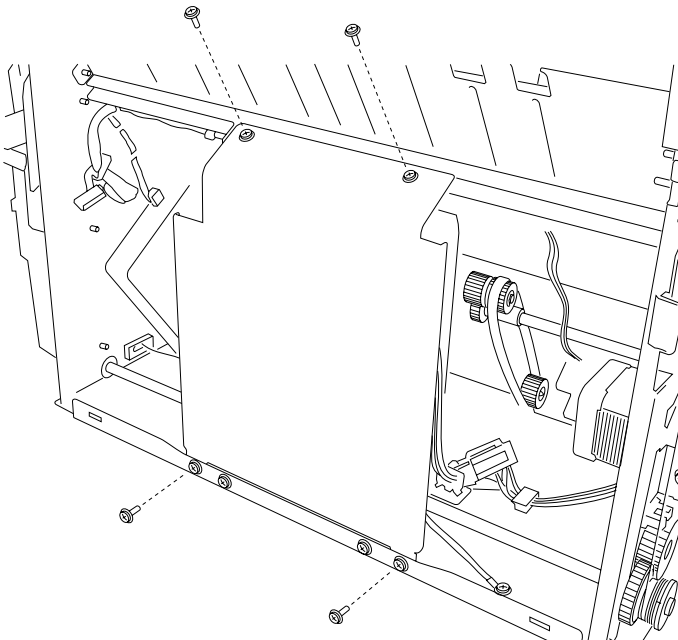

6. Remove the two power supply screws.
7. Remove the screw from the ground wire.
8. Disconnect the power supply connector and remove the power supply.

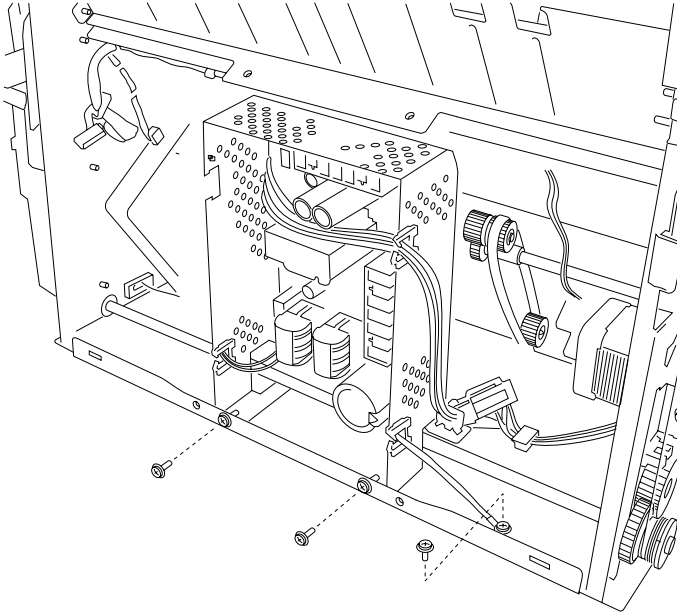

Registration roller removal

1. Remove the hole punch unit.
2. Remove the registration roller clutch.
3. Remove the registration roller bushing.
4. Remove the registration roller.

Registration roller clutch removal

1. Remove the harness from the clamp.
2. Remove the three control board mounting bracket screws and remove the bracket.

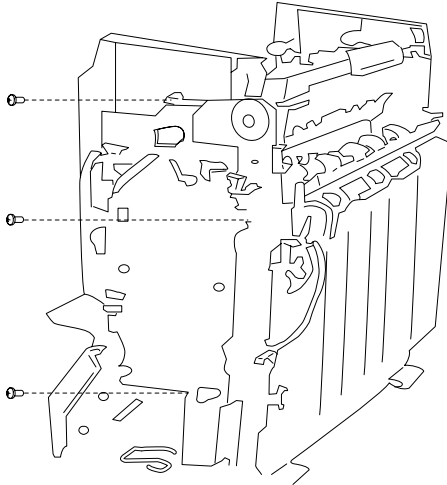

3. Remove the registration roller clutch set screw.
4. Remove the registration roller clutch connector.
5. Remove the registration roller clutch.

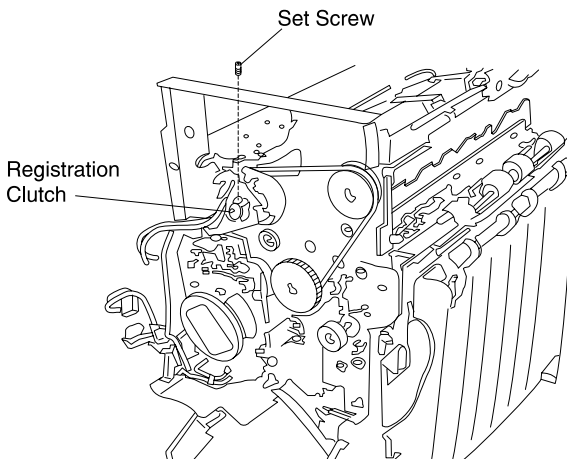

Stack area discharge brush removal

1. Remove the dust box.
2. Remove the stack area discharge brushes.

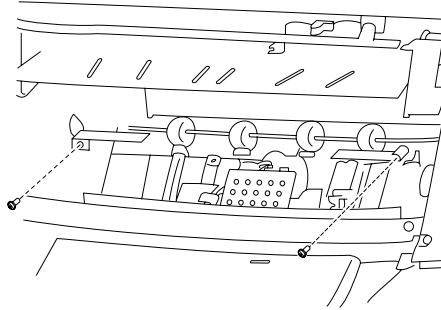

Staple unit removal

1. Remove the staple unit connector.

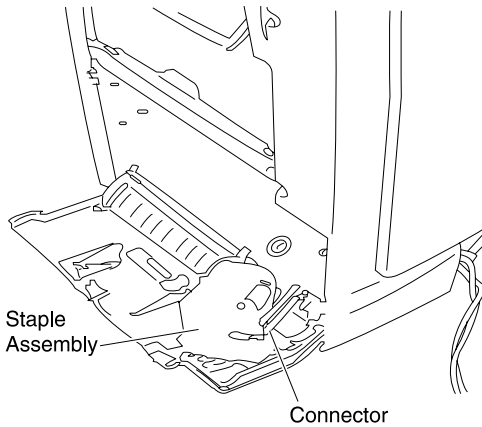

2. Pull outward on the staple cover and remove the staple unit.

Straight paper exit discharge brush removal

1. Remove the external covers.
2. Remove the two screws from the top cover and remove the cover.
3. Remove the two lever screws and remove the lever.
4. Remove the two discharge brush screws and remove the brush.

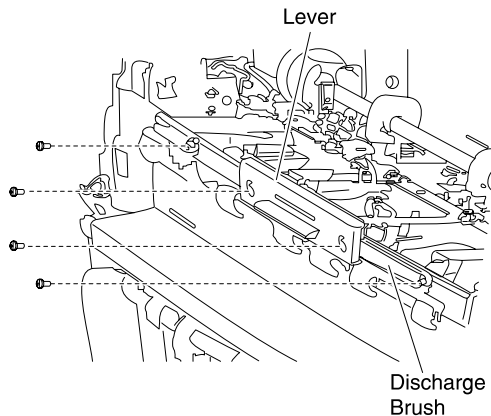

Straight paper exit roller removal

1. Remove the external covers.
2. Remove the finisher control board.
3. Remove the upper left panel.
4. Remove the front straight paper exit roller bushing.

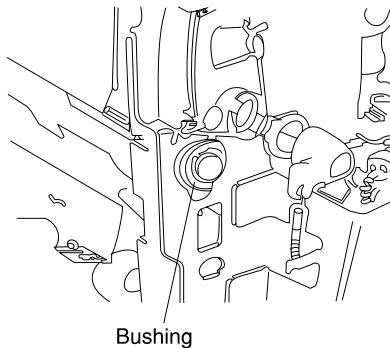

5. Remove the belt and pulley.

6. Remove the rear straight paper exit roller E-ring and bushing.

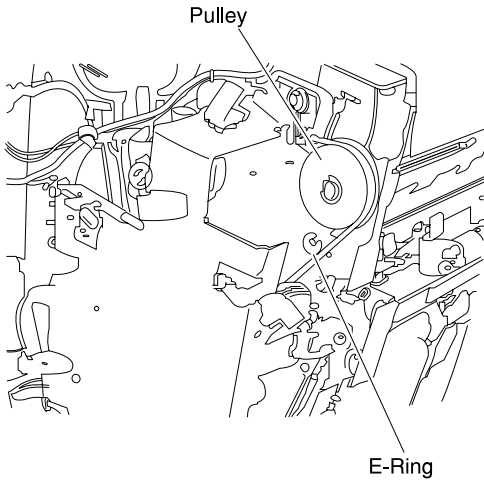

7. Remove the straight paper exit roller.

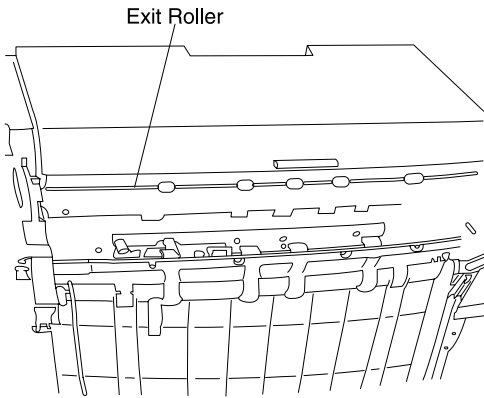

Timing belts 1 and 2 removal

1. Remove the finisher control board mounting bracket.
2. Remove the feed motor mounting bracket.
3. Remove the tension bracket mounting screw.
4. Remove the tension spring.
5. Remove the timing belt 1.

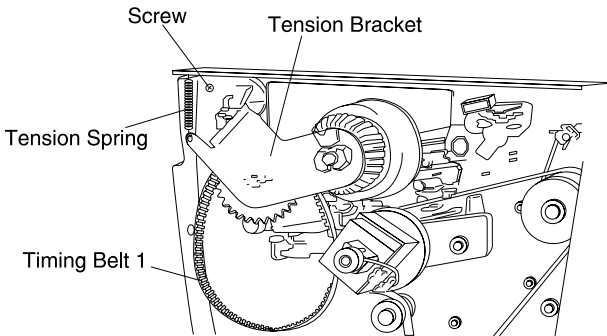

6. Loosen the tension bracket mounting screw for timing belt 2.
7. Remove the timing belt 2.

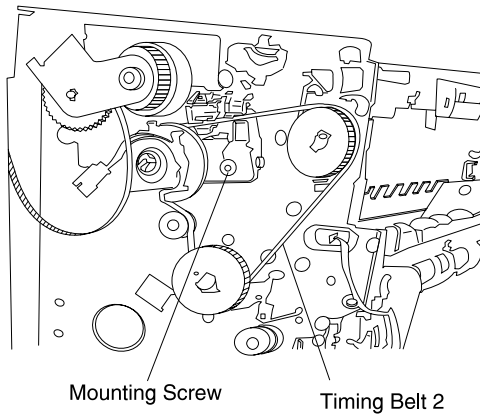

Tractor belt removal

1. Remove the external covers.
2. Remove the lower left panel.
3. Remove the cable connector of the left panel.
4. Remove the belt motor unit.
5. Remove the four lower guide support plate screws for the invert paper exit.

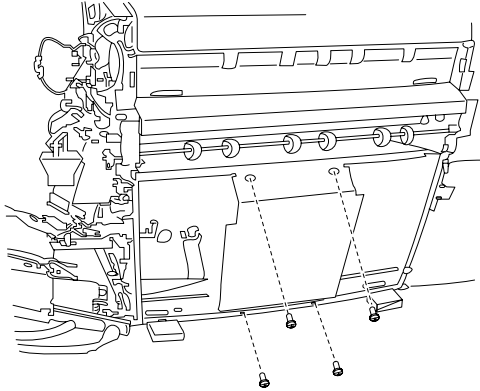

6. Remove the tension spring from the shaft.

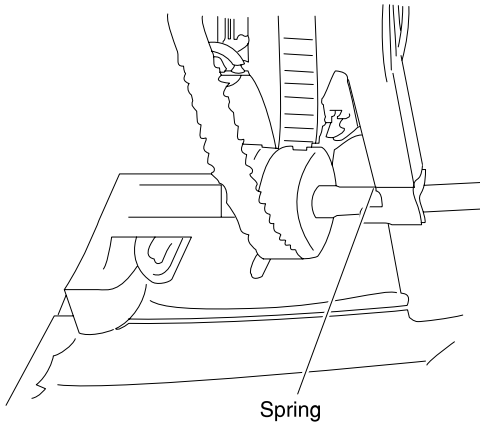

7. Remove the paper jam removal knob.

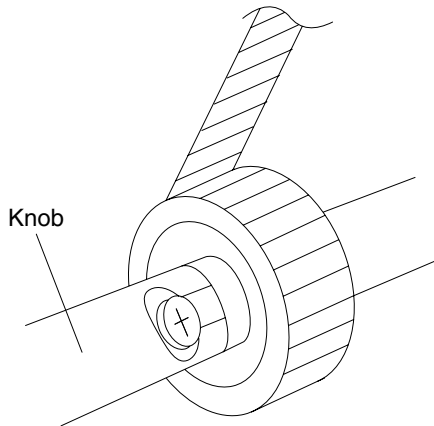

8. Remove the tractor belts.

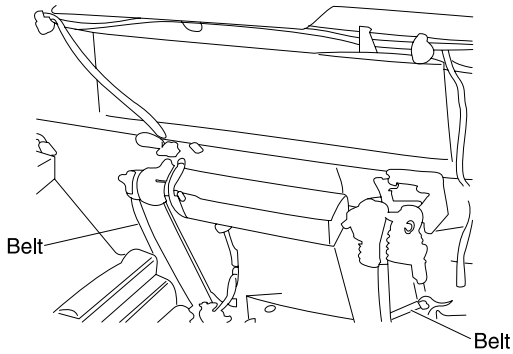

Note: Install the belt so that the belt tooth just under the plastic hook aligns with the hook on the other belt.

Tractor drive motor assembly removal

1. Remove the outer covers.
2. Remove the drive belt.

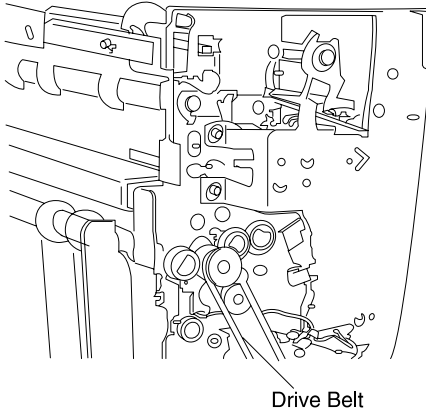

3. Remove the three screws and disconnect the connector from the tractor drive motor assembly.

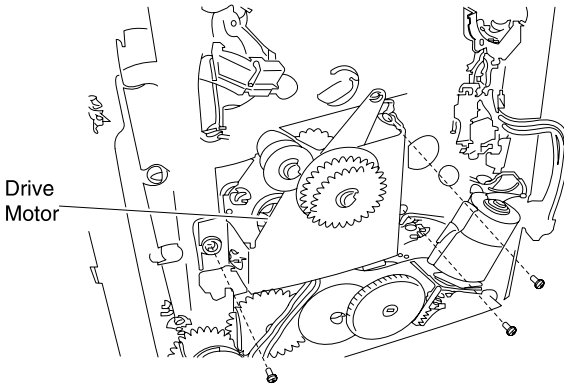

4. Remove the tractor drive motor assembly.

5. Locations

Covers diagram

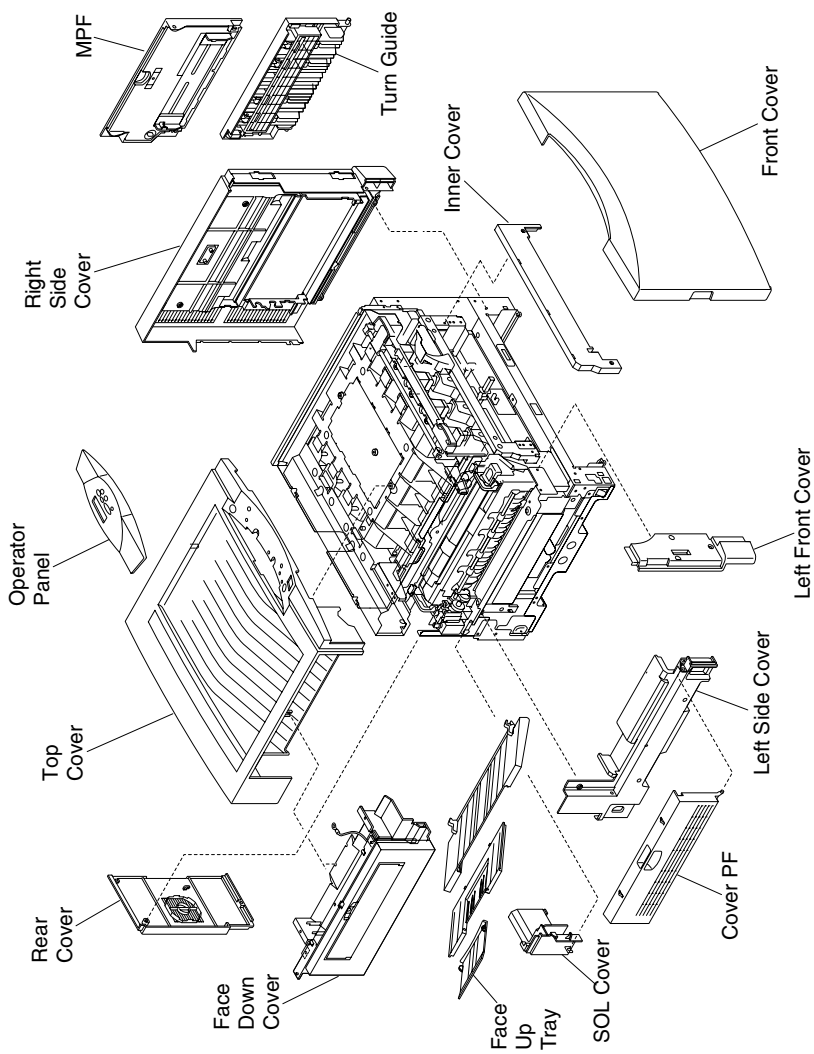

Major parts diagram

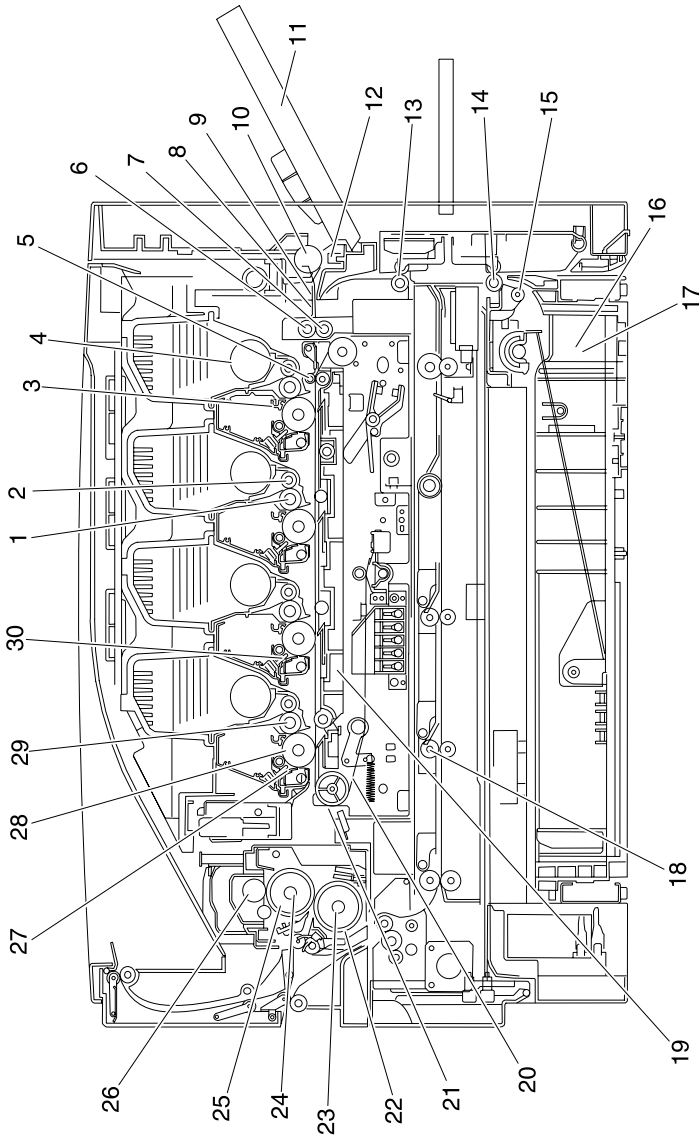

Major parts diagram, legend

	Part		Part
1	Development roll	16	Paper out detection lever
2	Supply roll	17	Paper out detection sensor
3	Doctor blade	18	Duplex unit
4	Agitator	19	Transfer sheet
5	Absorption roll	20	Transfer belt
6	Registration upper roll	21	Belt drive roller
7	Registration lower roll	22	Paper delivery detection lever
8	Registration sensor	23	Press roll
9	Registration detection lever	24	Heater
10	MPF roll	25	Fuser roller
11	MPF unit	26	Oil coating roller
12	Fanning pad	27	Cleaning blade
13	Upper feed roll	28	Photosensitive drum
14	Lower feed roll	29	Charged roll
15	Paper feed roll	30	LED head

Sensor and switch locations

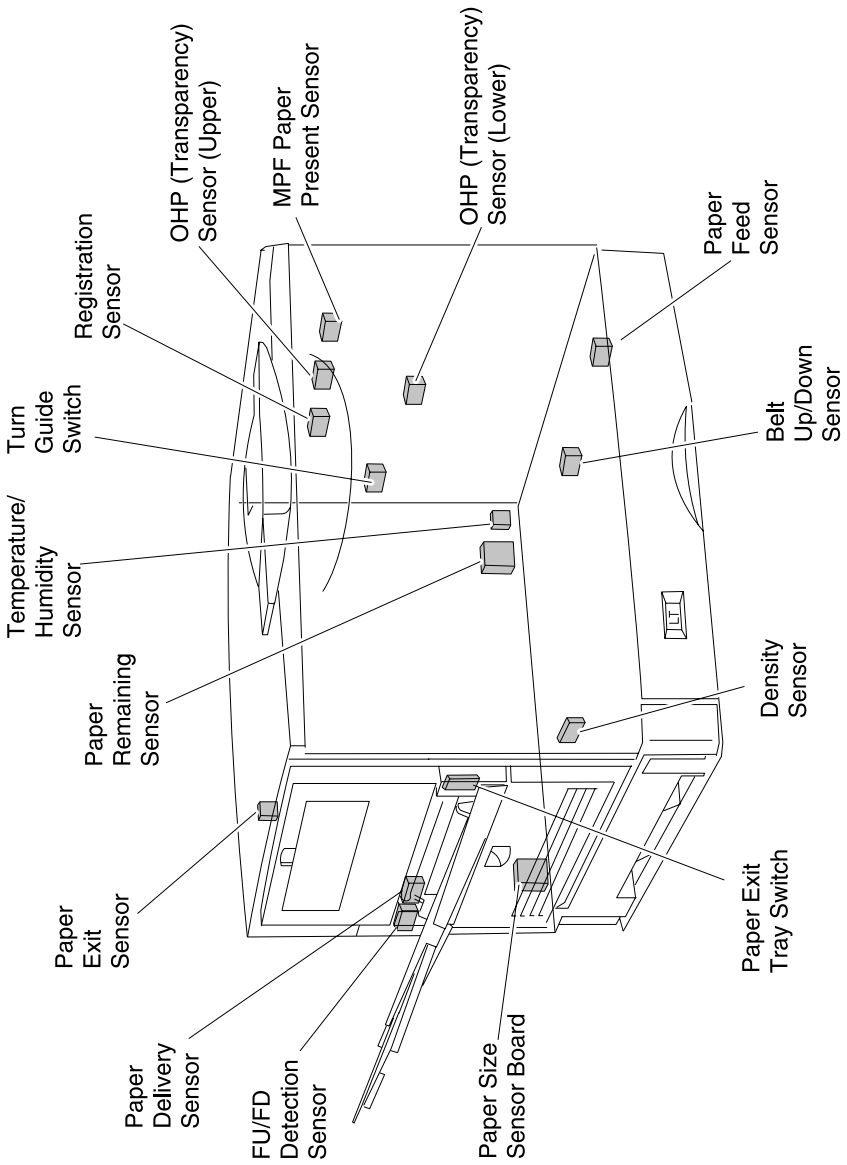

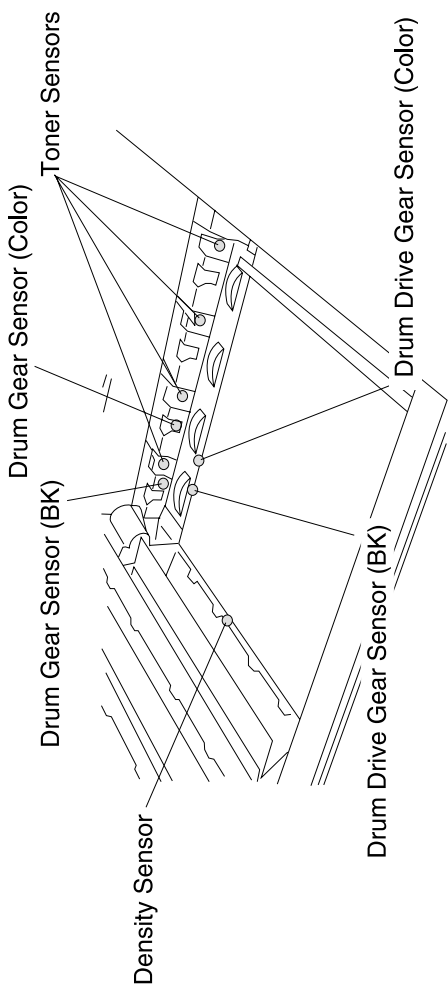

Component locations

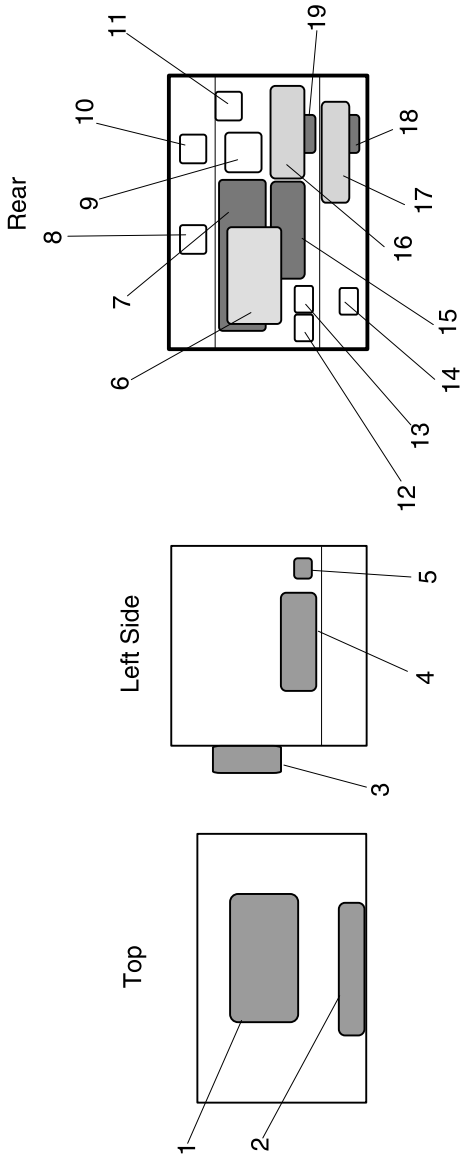

Component locations, legend

Number	Component
1	Printhead controller board
2	Operator panel
3	RIP box
4	Motor driver board
5	Power switch
6	Printer controller board
7	High voltage unit (HVU)
8	Upper left fan
9	Main drive motor
10	Upper right fan
11	Power supply fan
12	Temperature/humidity sensor
13	Paper remaining detection sensor (main unit)
14	Paper remaining detection sensor (expansion feeder)
15	Power supply 2
16	Power supply 1
17	Expansion feeder control board
18	Paper size sensor board (expansion feeder)
19	Paper size sensor board (main unit)

Printer controller board

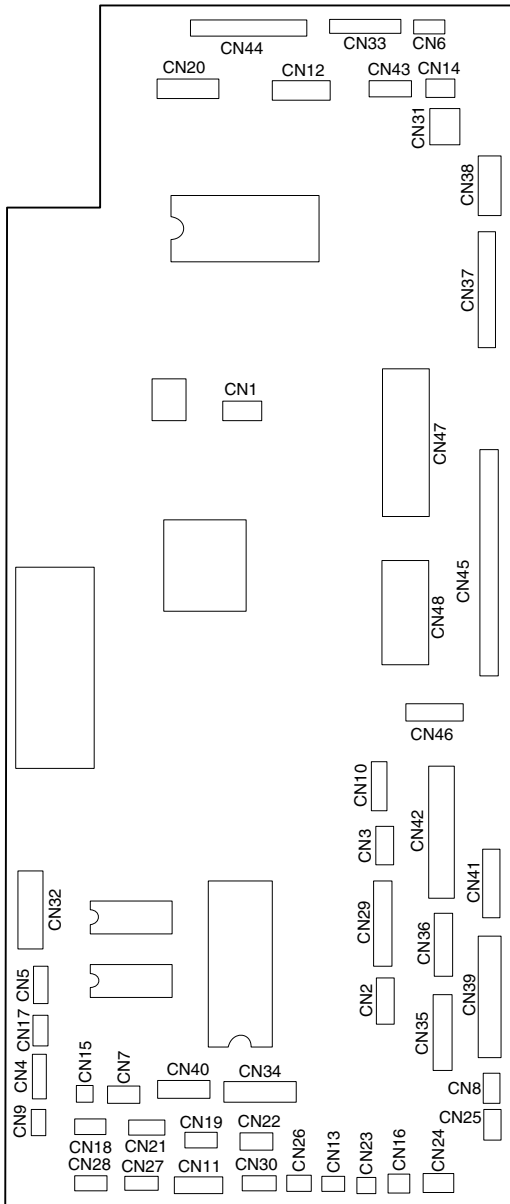

View from rear of printer

Printer controller board connectors

The connectors are listed in the order they appear on the engine board, beginning at CN20 in the top right and continuing clockwise around the edge of the board. Note the orientation of the printer controller board diagram.

Board connectors in this table are attached to the board and cable connectors are made up of various number of wires of various colors.

Vertical connectors list wire colors top to bottom. Horizontal connectors list wire colors left to right.

Printer controller board connectors

CN	Board connector orientation	Board conn. color	Cable conn. color	# wires in cable	Wire colors
20	Vertical	White	White	6	Black
12	Vertical	White	White	6	3 Blue, 3 gray
44	Vertical	White	White	11	1 Red, 1 black, 4 gray, 5 white
33	Vertical	White	White	6	Brown, blue, gray, white, black, yellow
6	Vertical	White	White	3	Black, yellow, red
14	Vertical	White	White	2	Blue
43 HV only	Vertical	White	White	4	3 Gray, 1 red
31	Horizontal	White	White	2	Black, red
38	Horizontal	White	White	4	Yellow, red, 2 black
37	Horizontal	White	White	13	Brown, red, orange, yellow, blue, purple, gray, white, brown, red, orange, yellow, blue
47	Horizontal	White	White	30	29 White, 1 blue
48	Horizontal	White	White	18	17 White, 1 blue

Printer controller board connectors (continued)

CN	Board connector orientation	Board conn. color	Cable conn. color	# wires in cable	Wire colors
46	Vertical	White	White	8	2 Green, 2 blue, 2 red, 2 yellow
45	Horizontal	Brown	Brown	80	1 Red, 79 brown (ribbon)
10	Horizontal	White	Green	6	Brown
3	Horizontal	White	White	4	Yellow, brown, black, blue
29	Horizontal	White	White	10	Brown, blue, gray, white, brown, yellow, blue, black, gray, white
2	Horizontal	White	White	4	Brown
42	Horizontal	White	White	15	Brown, blue, gray, white, yellow, brown, blue, gray, white, brown, blue, 2 red, black, yellow
36	Horizontal	White	White	7	White, gray, blue, 3 yellow, brown
35	Horizontal	White	White	5	Yellow, 2 black, red, black
41	Horizontal	White	White	6	Black, purple, orange, red, gray, white
39	Horizontal	White	White	8	2 red, 4 black, 2 yellow
8	Horizontal	White	White	3	Blue
25	Horizontal	Black	White	2	Black
24	Vertical	White	White	2	White
16	Vertical	Yellow	Yellow	2	Yellow
23	Vertical	Blue	Blue	2	Blue
13	Vertical	White	White	2	White

Printer controller board connectors (continued)

CN	Board connector orientation	Board conn. color	Cable conn. color	# wires in cable	Wire colors
26	Vertical	White	Gray	2	White
30	Vertical	White	White	2	Red, black
22	Vertical	Black	White	4	Black
34	Vertical	White	White	8	7 Black, white
11	Vertical	White	White	6	3 Black, 3 white
19	Vertical	Blue	White	4	Blue
40	Vertical	White	White	6	Yellow, 3 white, black, white
27	Vertical	Black	White	4	Black
21	Vertical	Yellow	White	4	Yellow
7	Vertical	White	White	3	White
28	Vertical	Yellow	White	4	Yellow
18	Vertical	Red	White	4	Red
15	Vertical	Black	Black	2	Black
9	Horizontal	White	White	3	Brown
4	Horizontal	White	White	4	Black, brown, orange, yellow
17	Horizontal	White	White	3	Black, yellow, red
5	Horizontal	White	White	3	Red, yellow, black
32	Horizontal	White	Gray	8	2 Black, 2 yellow, 2 blue, 2 red
1	Vertical	White	N/A	Empty	N/A

Printhead controller board

For printers with serial number XX-0XXXX:

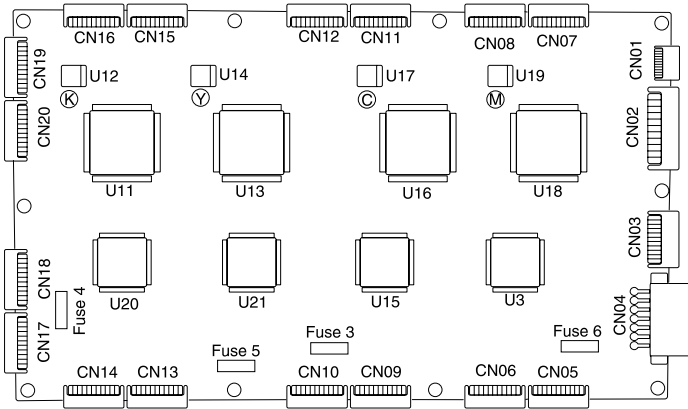

For printers with serial number XX-1XXXX:

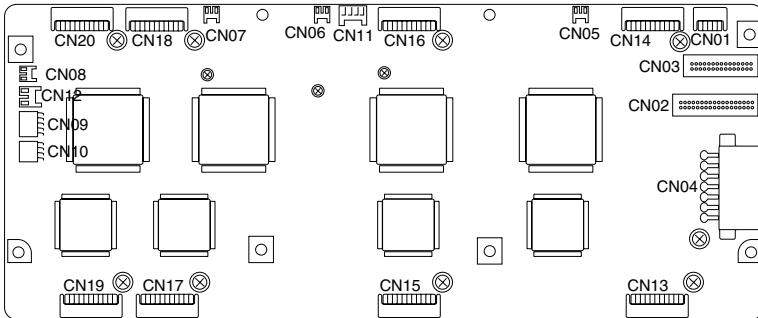

RIP board

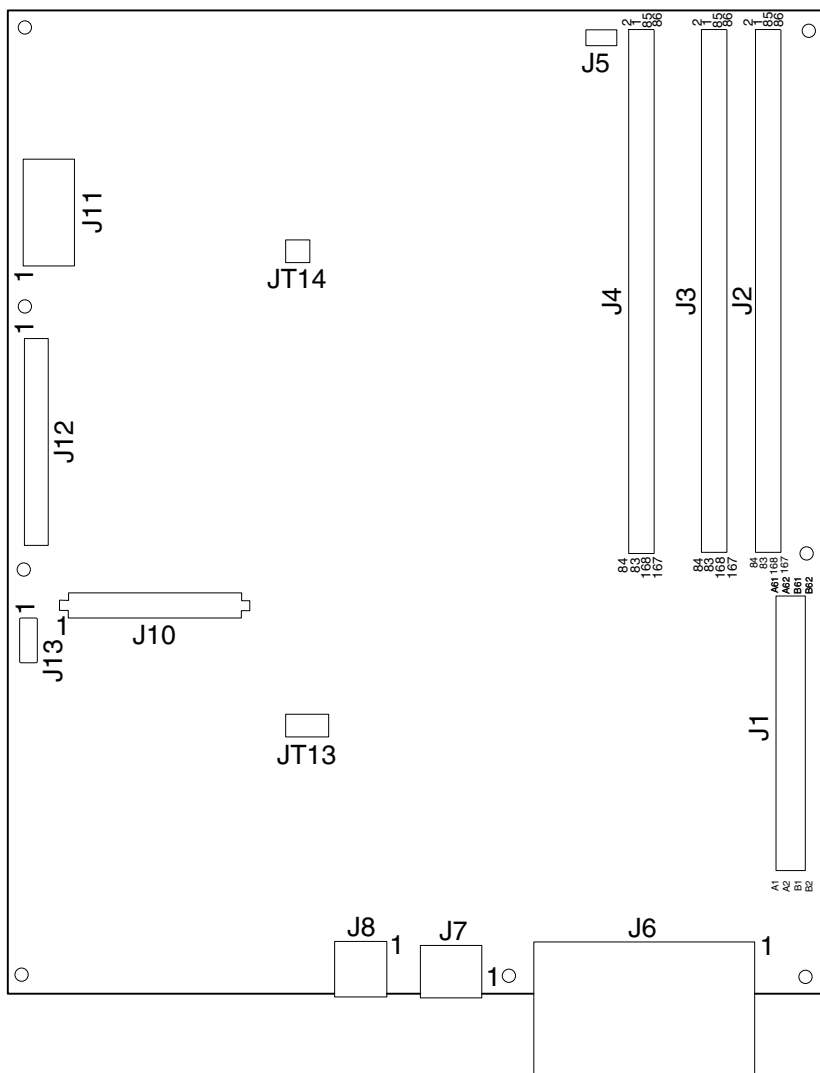

Power source unit 1 board

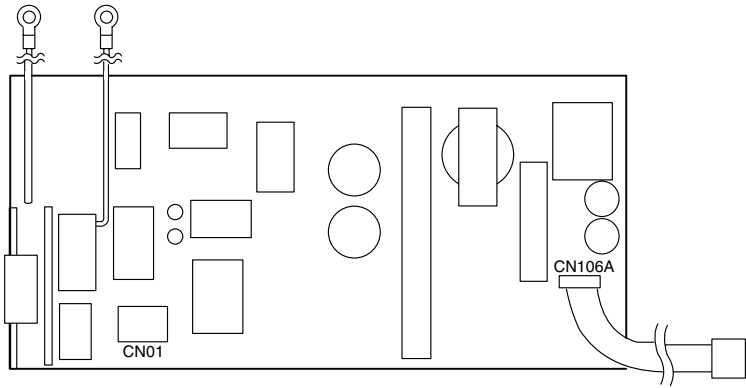

Power source unit 2 board

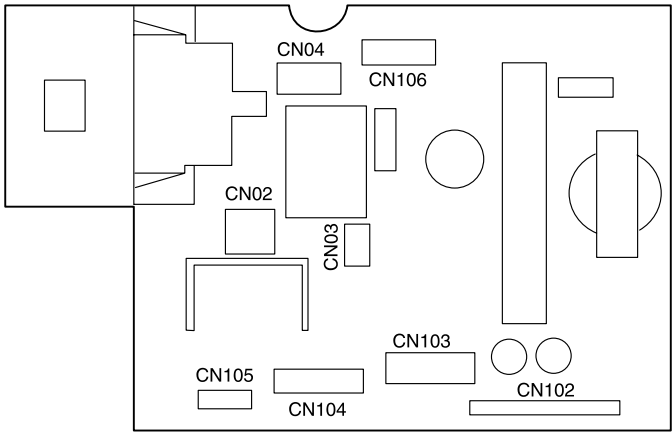

High voltage power supply board

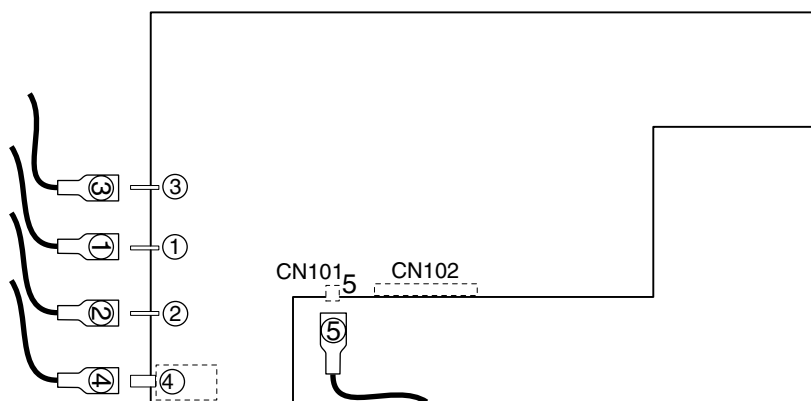

Sensor board

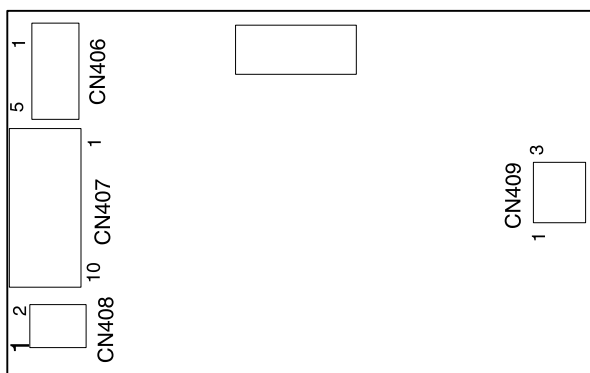

Expansion paper feeder controller board

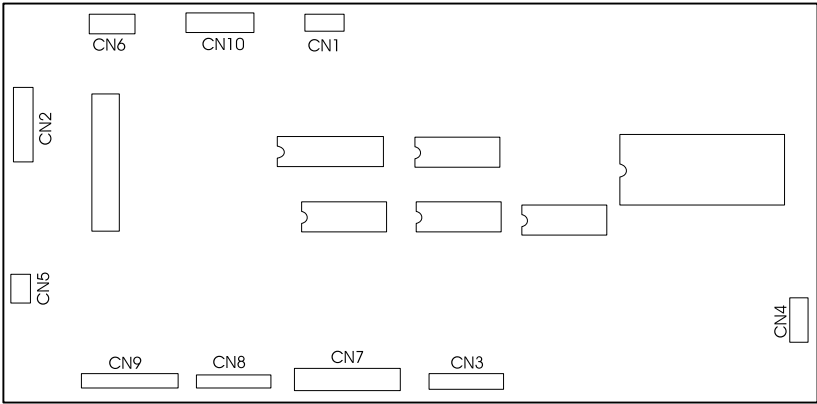

Duplex unit controller board

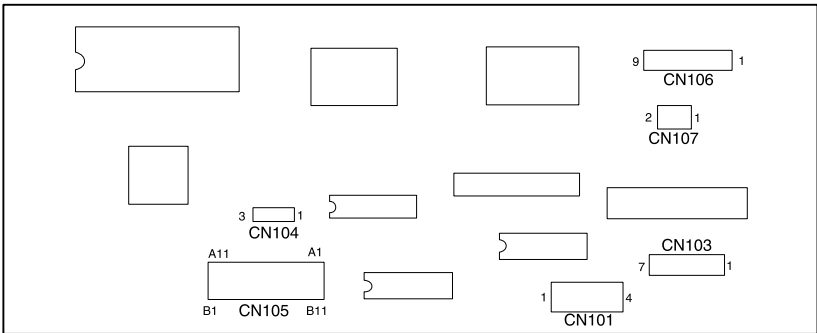

Motor drive board

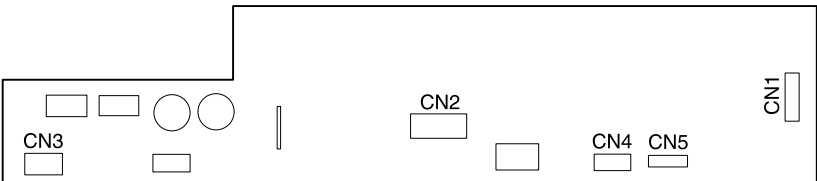

Size sensor board

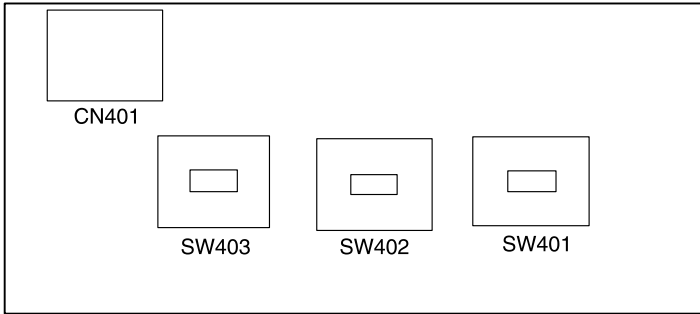

High-capacity feeder (HCF)

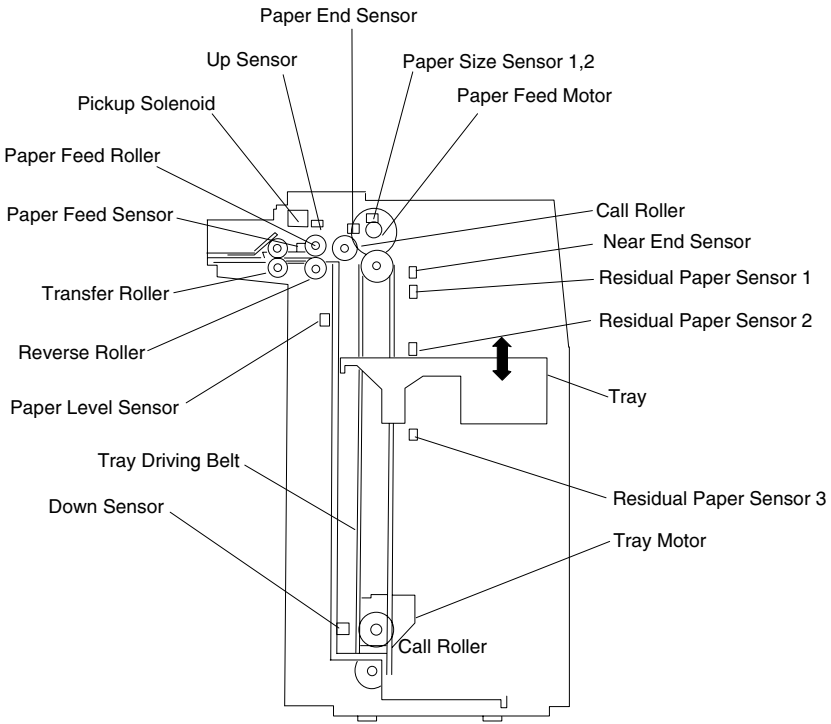

High-capacity paper feed configuration

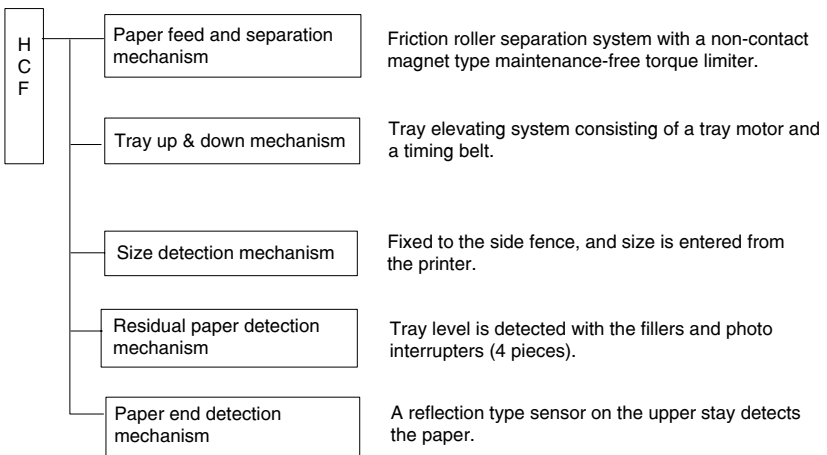

Electrical parts layout

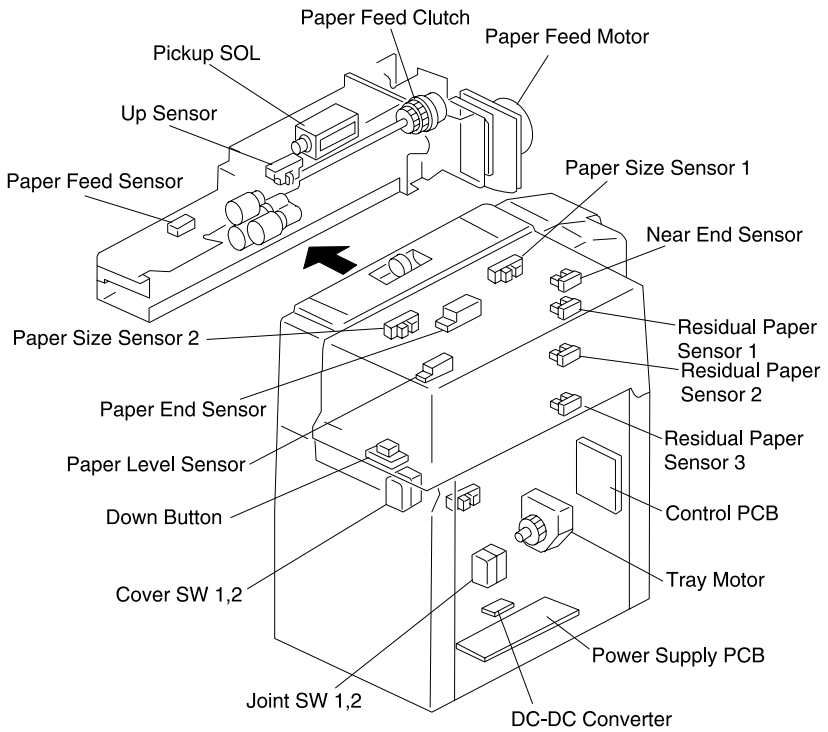

Driving parts layout

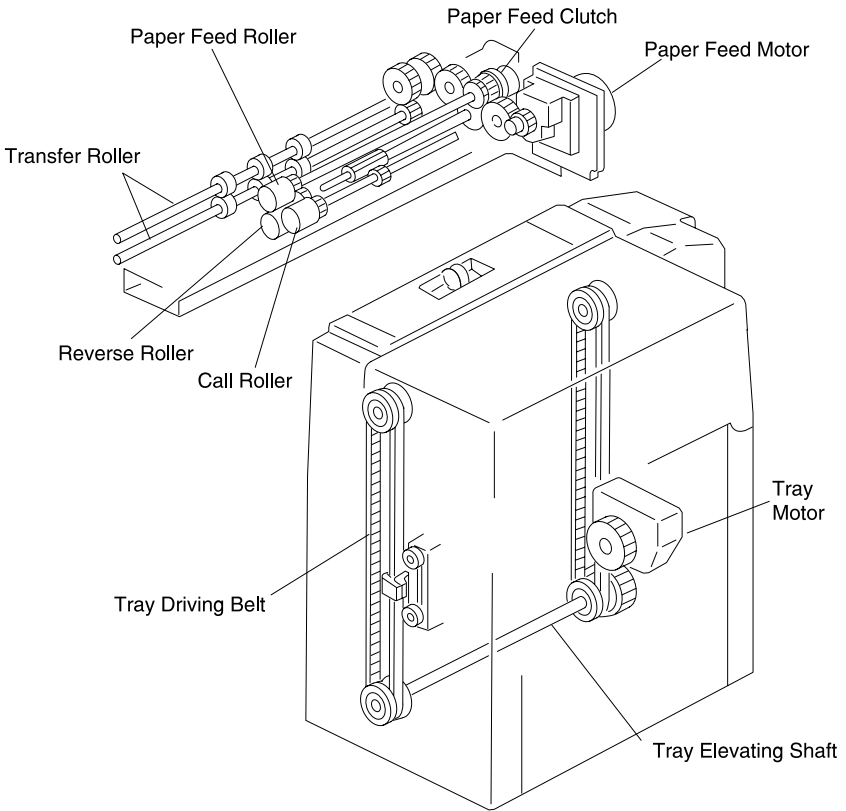

Finisher locations

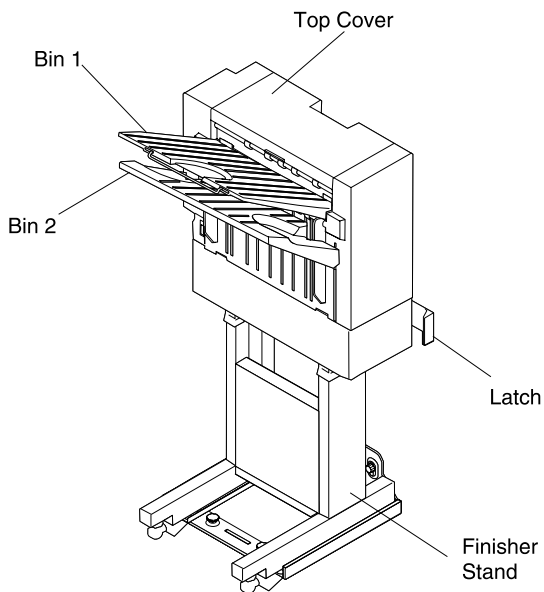
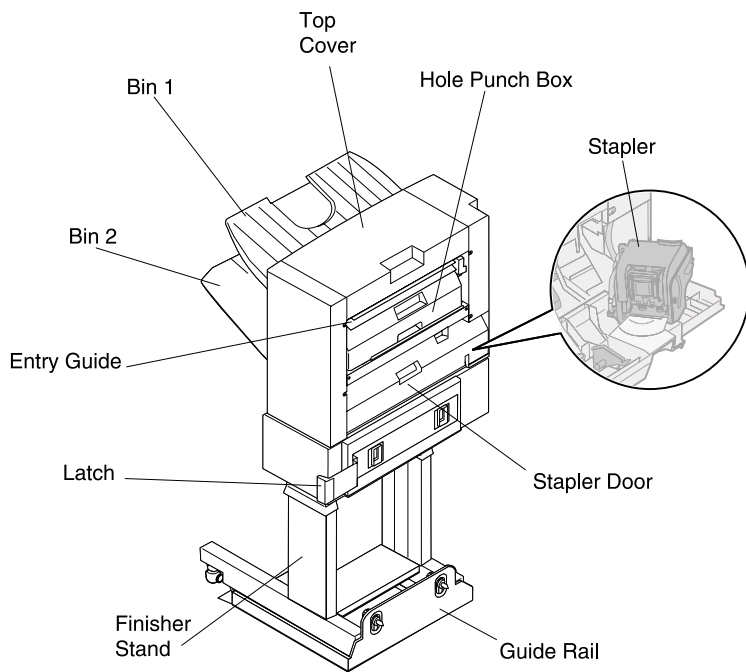

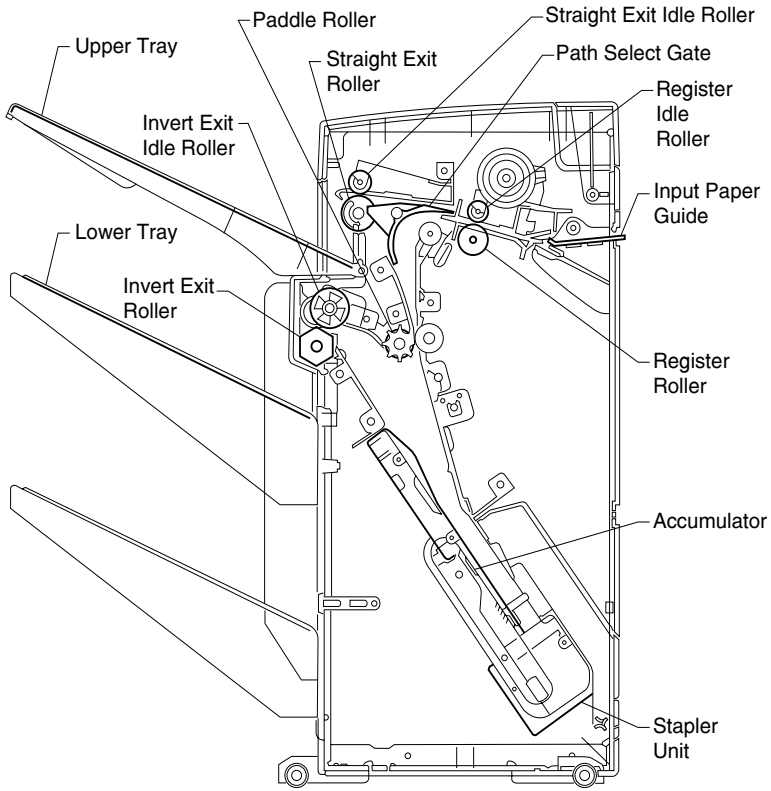

	Sensor, Switch	Purpose
A	Paper input path sensor	Detects paper input from printer
B	Paper registration sensor	Trigger for punching
C	Paper exit sensor (face up bin)	Confirming paper path
D	Tractor home position sensor	Finds home position for driving belt
E	Paper full sensor A	Detecting paper full on tray 2
F	Paper detecting sensor	Detects paper for stapling
G	Staple home position sensor	Finds home position for stapling
H	No staple sensor	Detects staple empty
I	Finisher set switch	Detects connection with printer
J	Staple cartridge set switch	Detects staple cartridge open
K	Punch box detect sensor	Detects punch box
L	Invert path sensor	Detects invert paper jam
M	Paper exit sensor (face down bin)	Confirming paper path
N	Elevator upper limit sensor	Detecting face down bin
P	Elevator lower limit sensor	Detecting face down bin
Q	Jogging home position sensor	Jogging home position for driving bar
R	Paper upper level sensor B	Detecting paper upper level

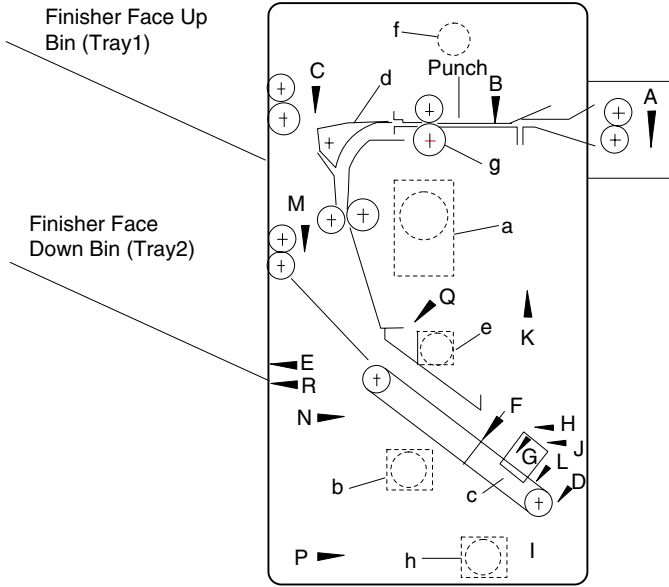

	Motor, Solenoid, Clutch	Purpose
a	Paper feed motor	Paper feeding and inverting
b	Tractor drive motor	Tractor drive for paper feeding
c	Staple motor	Stapling
d	Path select solenoid	Path changing
e	Paper jogging motor	Jogging of paper
f	Punch clutch	Punching
g	Registration clutch	Paper registration/feeding
h	Elevator motor	Face down bin movement

Finisher electrical parts

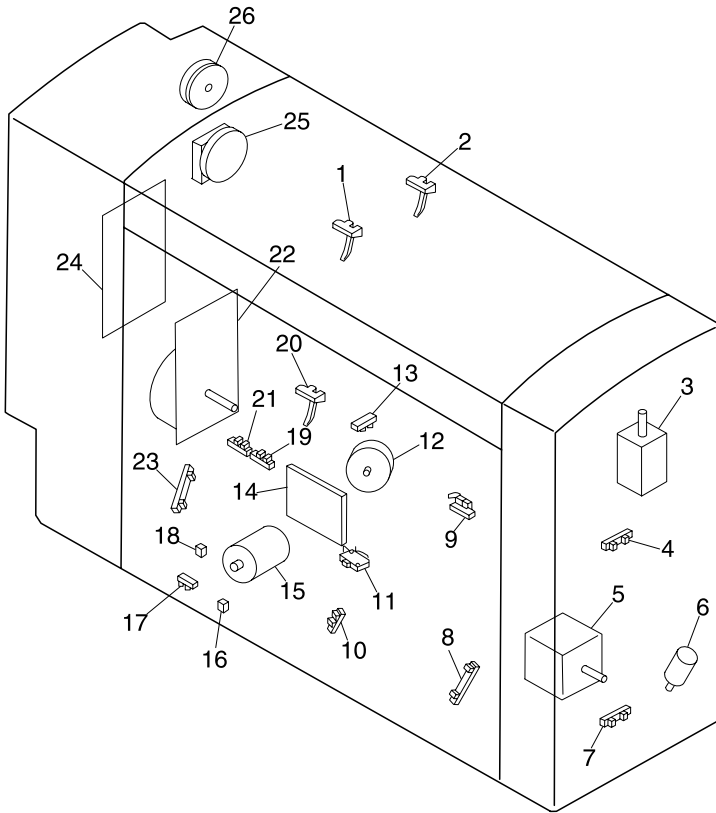

Number	Part name	Number	Part name
1	Paper exit sensor (upper tray)	14	Power supply PWBA
2	Paper register sensor	15	Staple motor
3	Path select solenoid	16	Staple existence sensor
4	Elevator upper limit Sensor	17	Staple home position sensor
5	Tractor drive motor	18	Staple cartridge set switch
6	Elevator motor	19	Paper upper level sensor B
7	Elevator lower limit sensor	20	Paper exit sensor (lower tray)
8	Invert path sensor	21	Paper full sensor A
9	Punch box detect sensor	22	Paper feed motor
10	Belt home position sensor	23	Paper detecting sensor
11	Finisher set switch	24	Finisher control board
12	Paper jogging motor	25	Registration clutch
13	Jogging home position sensor	26	Punch clutch

5055-xxx

6. Preventive maintenance

Maintenance kit

When nearing the end-of-life of the fuser or transfer belt, the following message appears, indicating that it's time to replace the fuser unit and/or transfer belt unit:

80 Belt Life Warning and/or 80 Fuser Life Warning

Routine replacement of these parts ensures peak printer performance and helps prevent print quality problems and paper feed problems resulting from worn parts. The parts are in the maintenance kits listed.

Maintenance kit P/N	Unit	Printer power supply
56P9903	Transfer Belt	115 V—230 V
56P9900	Fuser	115 V
56P9901	Fuser	230 V

The status message appears until the appropriate part(s) is replaced.

Periodic maintenance

This table lists the parts to be periodically cleaned by the servicer.

Part name	Method
Paper feed unit: <ul style="list-style-type: none"> • Paper feed roller • MPF roll 	Remove any dust or dirt, and wipe the surface lightly with a dry cloth. If it is still dirty, clean with a soft cloth and alcohol.
Registration unit: Registration roller, upper, and lower	Remove any dust or dirt, and wipe the surface lightly with a dry cloth. If it is still dirty, clean with a soft cloth and alcohol.
Charge/exposure unit: LED head	Remove any dust or dirt, and wipe the surface lightly with a dry cloth. If it is still dirty, clean with a soft cloth and alcohol.
Transfer unit: Transfer belt	Remove any dust or dirt, and wipe the surface lightly with a dry cloth. If it is still dirty, clean with a soft cloth and alcohol.
Fuser unit: Heat rollers	Clean with a soft cloth, silicon oil, or alcohol.
Outer covers	Use a synthetic detergent and a damp cloth.

Lubricants and cleaners

Lubricating	Cleaning
<ul style="list-style-type: none"> • Oil—#10 Apply between gears and shafts. • Grease—# 23 Apply to gears. 	Alcohol or isopropyl on plastic, rubber, and external parts.

7. Parts catalog

How to use this parts catalog

- **SIMILAR ASSEMBLIES:** If two assemblies contain a majority of identical parts, they are shown on the same list. Common parts are shown by one index number. Parts peculiar to one or the other of the assemblies are listed separately and identified by description.
- **NS: (Not Shown)** in the Asm–Index column indicates that the part is procurable but is not pictured in the illustration.

Assembly 1: Covers 1

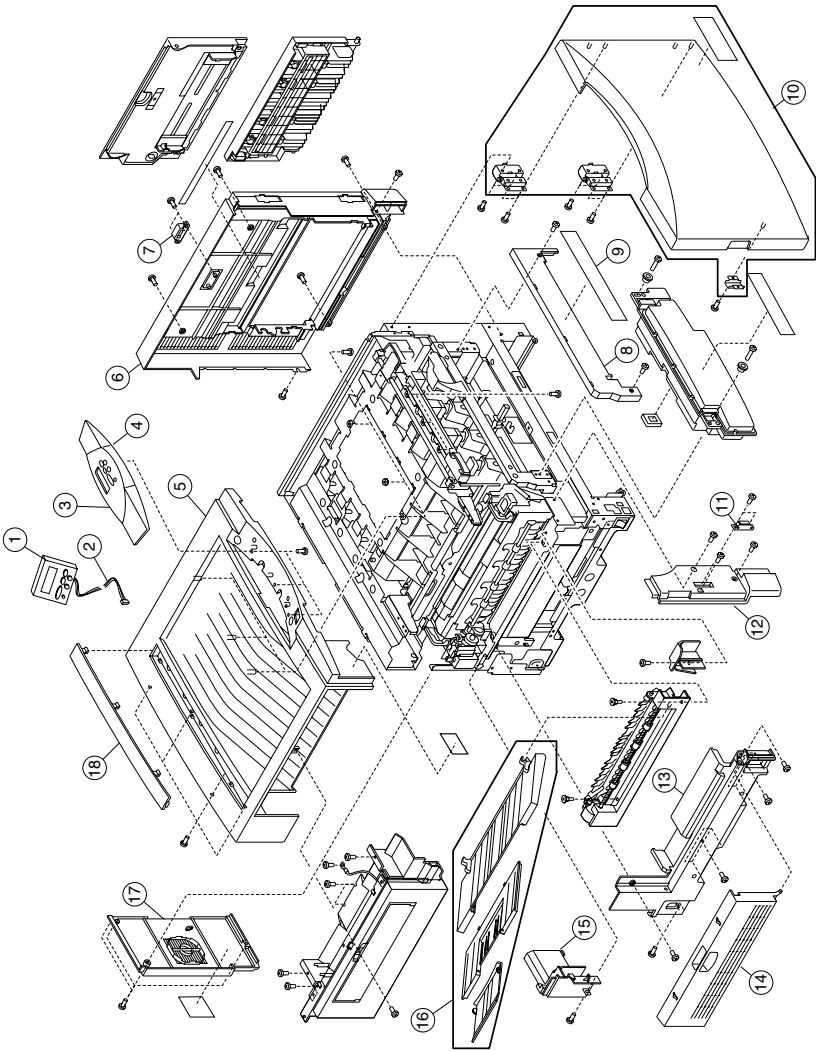

Assembly 1: Covers 1

Index	P/N	Units	Description
1 – 1	12G7360	1	Board, operator panel
1	99A1501	1	Board operator panel (Japan)
2	56P9736	1	Cable, operator panel
3	56P9555	1	Housing, upper operator panel
4	56P9556	1	Housing, lower operator panel
5	56P9539	1	Cover, top
6	56P9533	1	Cover assembly, right side
7	56P9534	1	Magnet, right side latch
8	56P9540	1	Cover, waste toner bottle
9	56P9545	1	Label, operator guide
10	56P9532	1	Cover assembly, front (C910)
10	56P9970	1	Cover assembly, front (C912)
11	56P9543	1	Magnet, front cover latch
12	56P9542	1	Cover, left front
13	56P9536	1	Cover, left side
14	56P9537	1	Cover, paper feed
15	56P9535	1	Cover, solenoid
16	56P9531	1	Tray assembly, exit
17	56P9538	1	Cover, rear
18	56P9551	1	Cover, adjustment
NS	56P9544	1	Label, MPT
NS	56P9554	3	Core, ferrite
NS	56P9905	1	Kit, operator panel overlay
NS	56P9945	1	Parts packet

Assembly 2: Covers 2

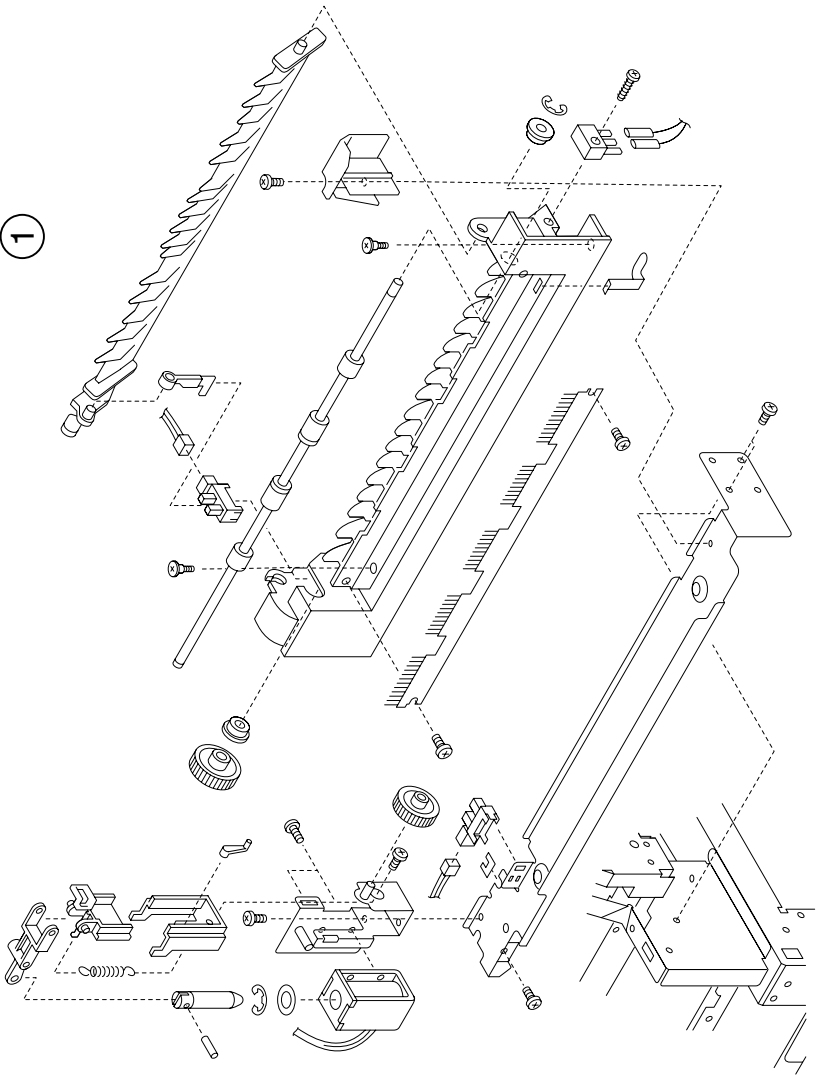

Assembly 2: Covers 2

Index	P/N	Units	Description
2-1	56P9557	1	Exit assembly, face up

Assembly 3: Covers 3

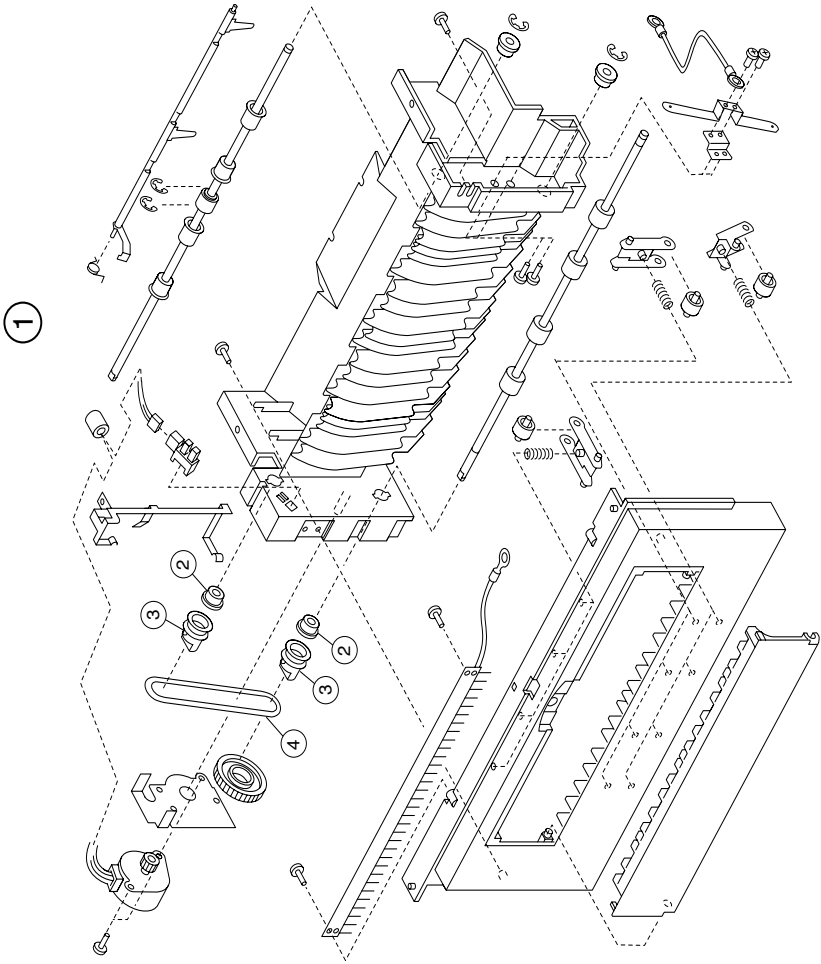

Assembly 3: Covers 3

Index	P/N	Units	Description
3-1	56P9566	1	Guide assembly, face-down
2	56P9575	4	Bushing, face down pinch roller
3	56P9576	2	Pulley, face down feed roller
4	56P9578	1	Belt, face down roller

Assembly 4: Covers 4

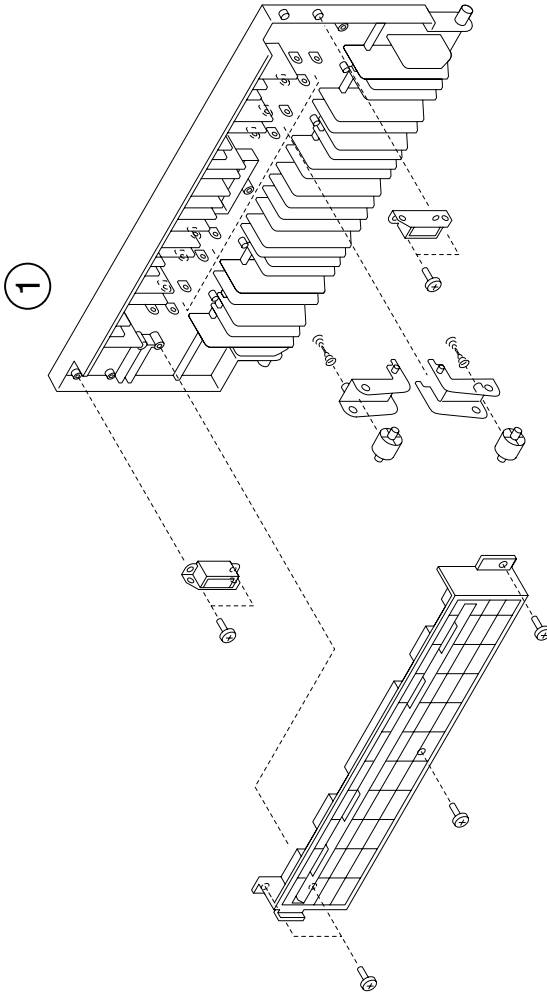

Assembly 4: Covers 4

Index	P/N	Units	Description
4-1	56P9584	1	Guide assembly, turn

Assembly 5: Covers 5

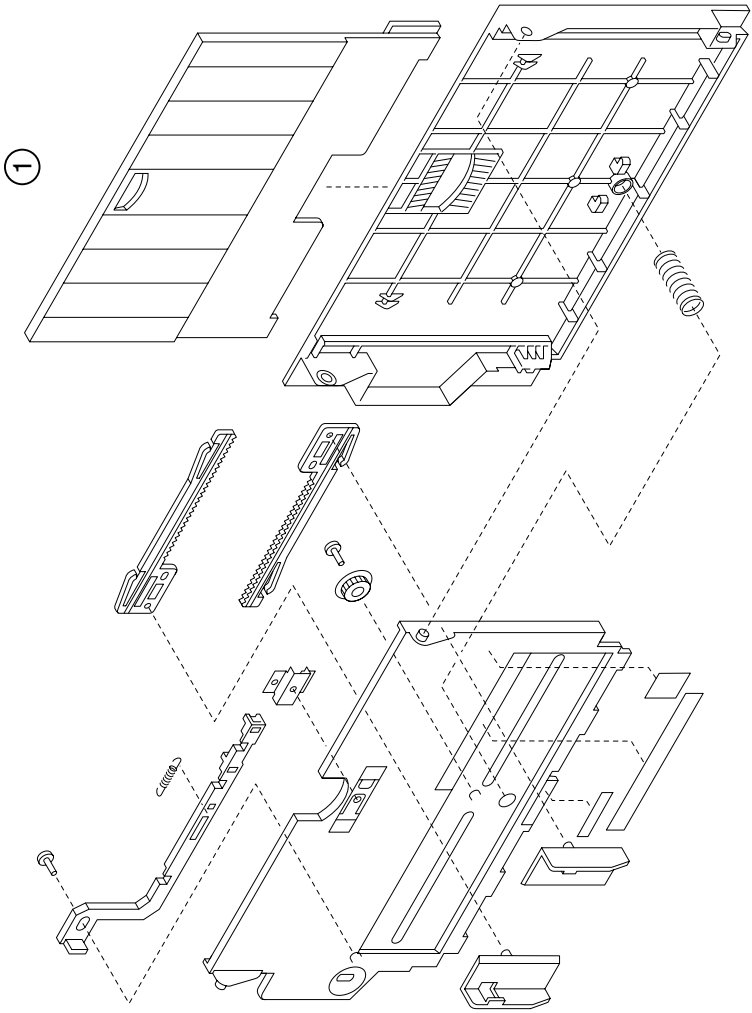

Assembly 5: Covers 5

Index	P/N	Units	Description
5-1	56P9972	1	Feeder assembly, multipurpose

Assembly 6: Upper unit

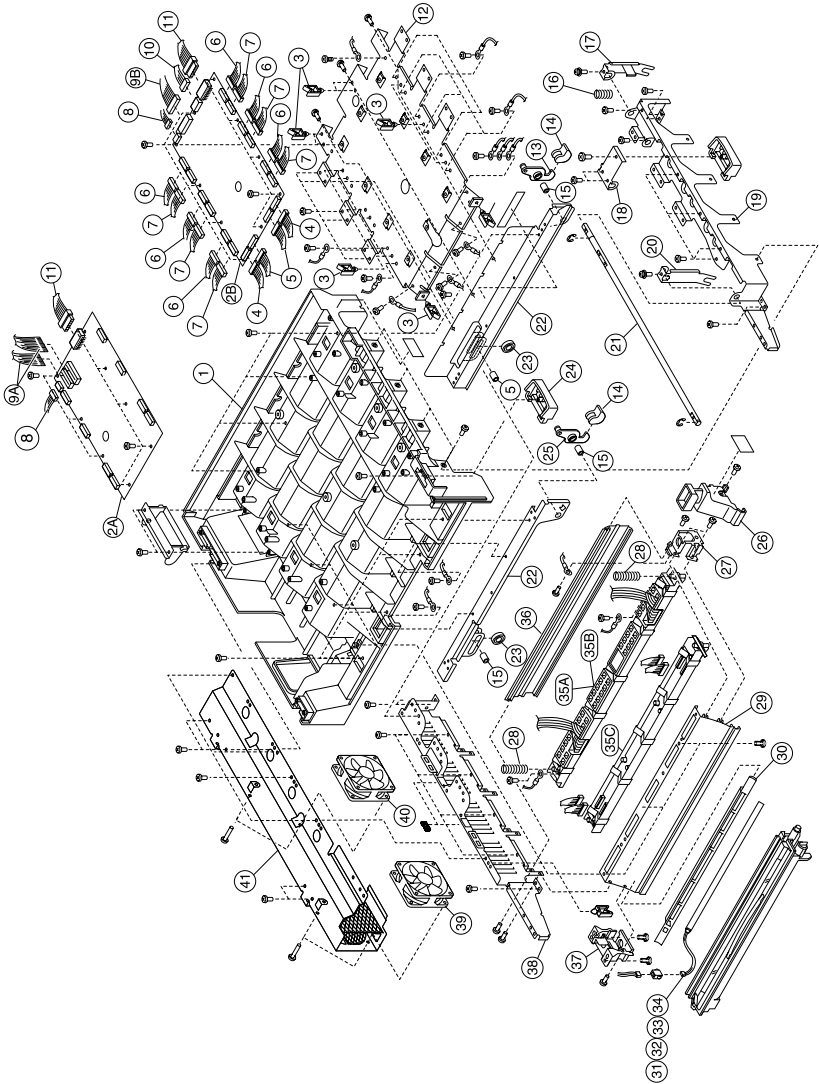

Assembly 6: Upper unit

Index	P/N	Units	Description
6-1	56P9591	1	Frame, upper
2A	56P9987	1	Board, printhead controller-S/N XX-1XXXX
2B	56P9620	1	Board, printhead controller-S/N XX-0XXXX
3	56P9638	6	Holder, cable
4	56P9600	2	Cable assembly, K13
5	56P9601	2	Cable assembly, K24
6	56P9602	6	Cable assembly, CL13
7	56P9603	6	Cable assembly, CL24
8	56P9716	1	Cable assembly, 8-pin PH controller
9A	56P9991	1	Cable assembly 48-pin PH controller-S/N XX-1XXXX
9B	56P9718	1	Cable assembly, 30-pin PH controller-S/N XX-0XXXX
10	56P9717	1	Cable assembly, 18-pin PH controller-S/N XX-0XXXX
11	56P9720	1	Cable assembly, PH controller power
12	56P9637	1	Frame, printhead controller
13	56P9625	1	Hook, right link
14	56P9626	2	Cover, hook
15	56P9628	4	Pivot, color link
16	56P9614	1	Spring, return
17	56P9618	1	Hook, right
18	56P9615	1	Hook, middle
19	56P9612	1	Bracket, front upper
20	56P9617	1	Hook, left
21	56P9613	1	Rod, interlocking
22	56P9624	1	Link, frame
23	56P9627	2	Bearing, roller
24	56P9616	2	Handle, upper opening
25	56P9630	1	Hook, left link
26	56P9611	4	Holder, front printhead
27	56P9608	4	Holder, front HSP
28	56P9609	8	Spring, printhead
29	56P9592	4	Rail, left side

Assembly 6 (continued): Upper unit

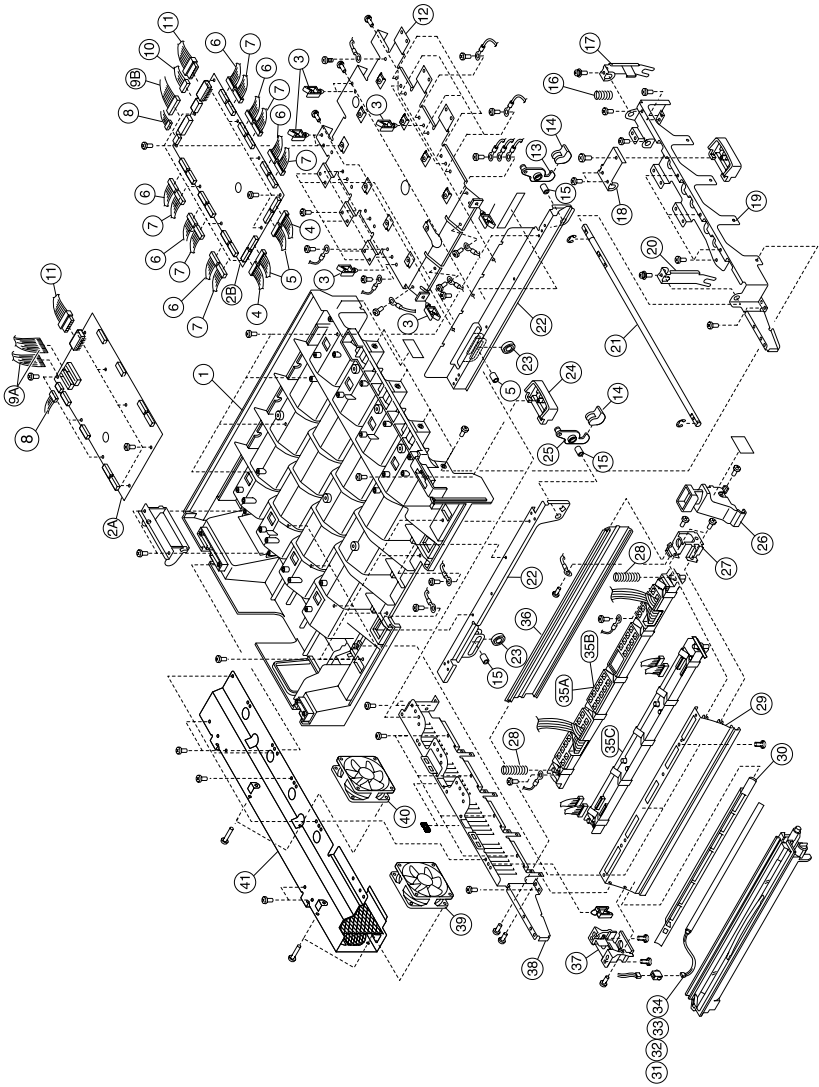

Assembly 6 (continued): Upper unit

Index	P/N	Units	Description
30	56P9594	4	Cover, eraser
31	56P9595	1	Lamp, M erase
32	56P9596	1	Lamp, C erase
33	56P9597	1	Lamp, Y erase
34	56P9598	1	Lamp, K erase
35A	56P9985	1	Printhead, LED K (black)—S/N XX-1XXXX
35B	56P9986	3	Printhead, LED Y/M/C (color)—S/N XX-1XXXX
35C	56P9599	4	Printhead, LED—S/NXX-0XXXX
36	56P9610	4	Rail, right side
37	56P9593	4	Holder, rear printhead
38	56P9619	1	Bracket, rear upper
39	56P9622	1	Fan, upper right
40	56P9623	1	Fan, upper left
41	56P9621	1	Bracket, fan holder
NS	56P9629	1	Frame, link
NS	56P9639	4	Connector, upper
NS	56P9604	8	Core, ferrite
NS	56P9605	8	Cable assembly, HDFG
NS	56P9606	4	Cable assembly, RSPFG
NS	56P9607	2	Cable assembly, LFG
NS	56P9993	4	Shield, light—used on P/N 56P9594 for S/N XX-1XXXX
NS	56P9947	1	Parts packet
NS	56P9988	1	Post, mini—S/N XX-1XXXX
NS	56P9989	1	Core, Ferrite—S/N XX-1XXXX
NS	56P9990	1	Tape, Core—S/N XX-1XXXX

Assembly 7: Base 1

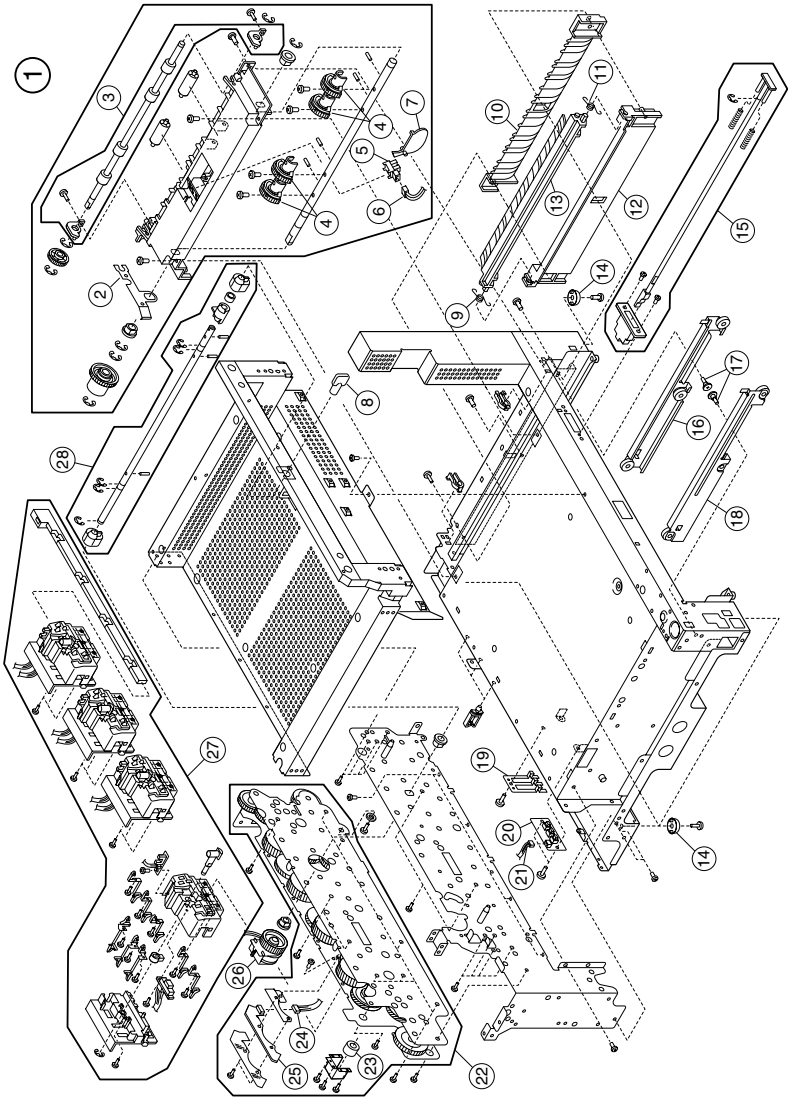

Assembly 7: Base 1

Index	P/N	Units	Description
7-1	56P9664	1	Frame, paper feed
2	56P9508	1	Bracket, ground
3	56P9512	1	Roller assembly, paper carrying
4	56P9511	4	Roller assembly, paper feed
5	11G0243	1	Interrupter, photo
6	56P9665	1	Sensor, paper feed
7	56P9507	1	Actuator, paper feed sensor
8	56P9520	1	Handle, waste bottle cam
9	56P9517	1	Spring, right cassette guide
10	56P9519	1	Guide, lower right cassette
11	56P9516	1	Spring, left cassette guide
12	56P9518	1	Guide, lower left cassette
13	56P9515	1	Guide, upper cassette
14	56P9503	4	Foot, rubber
15	56P9641	1	Actuator, front cover open switch
16	56P9505	1	Rail, base left side
17	56P9524	2	Screw, slide rail
18	56P9504	1	Rail, base right side
19	56P9521	1	Lever, size sensor
20	56P9522	1	Board, size sensor
21	56P9523	1	Cable assembly, size sensor
22	56P9642	1	Unit, drive
23	56P9643	1	Clutch, drive unit
24	56P9644	1	Cable assembly, drive unit sensor
25	56P9645	1	Sensor, drive unit gear
26	56P9663	1	Clutch, belt up/down
27	56P9646	1	Frame, sub
28	56P9662	1	Shaft, changing
NS	56P9948	1	Parts packet

Assembly 8: Base 2

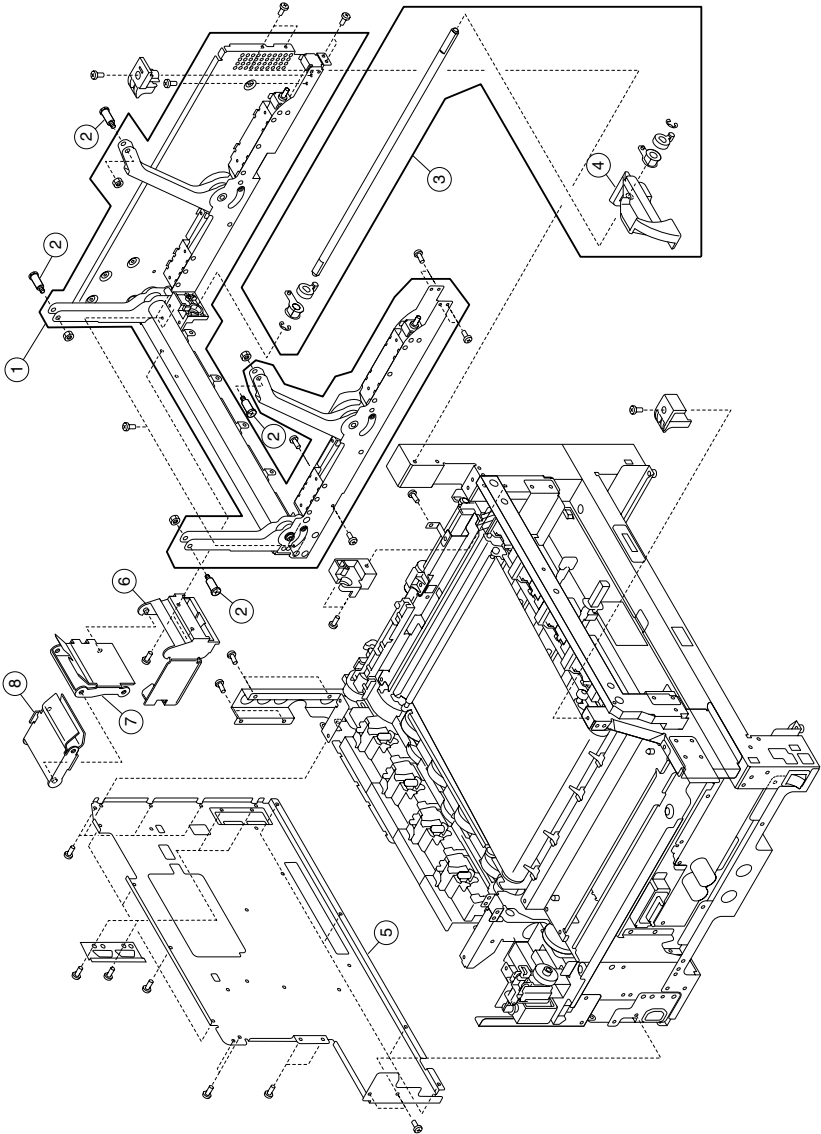

Assembly 8: Base 2

Index	P/N	Units	Description
8-1	56P9666	1	Support assembly, upper unit
2	56P9667	4	Pin, upper unit support
3	56P9668	1	Handle assembly, lock
4	56P9669	1	Handle, lock
5	56P9673	1	Cover, electronic
6	56P9670	1	Shroud, cable
7	56P9672	1	Guide, cable
8	56P9671	1	Guide, cable
NS	56P9949	1	Parts packet

Assembly 9: Base 3

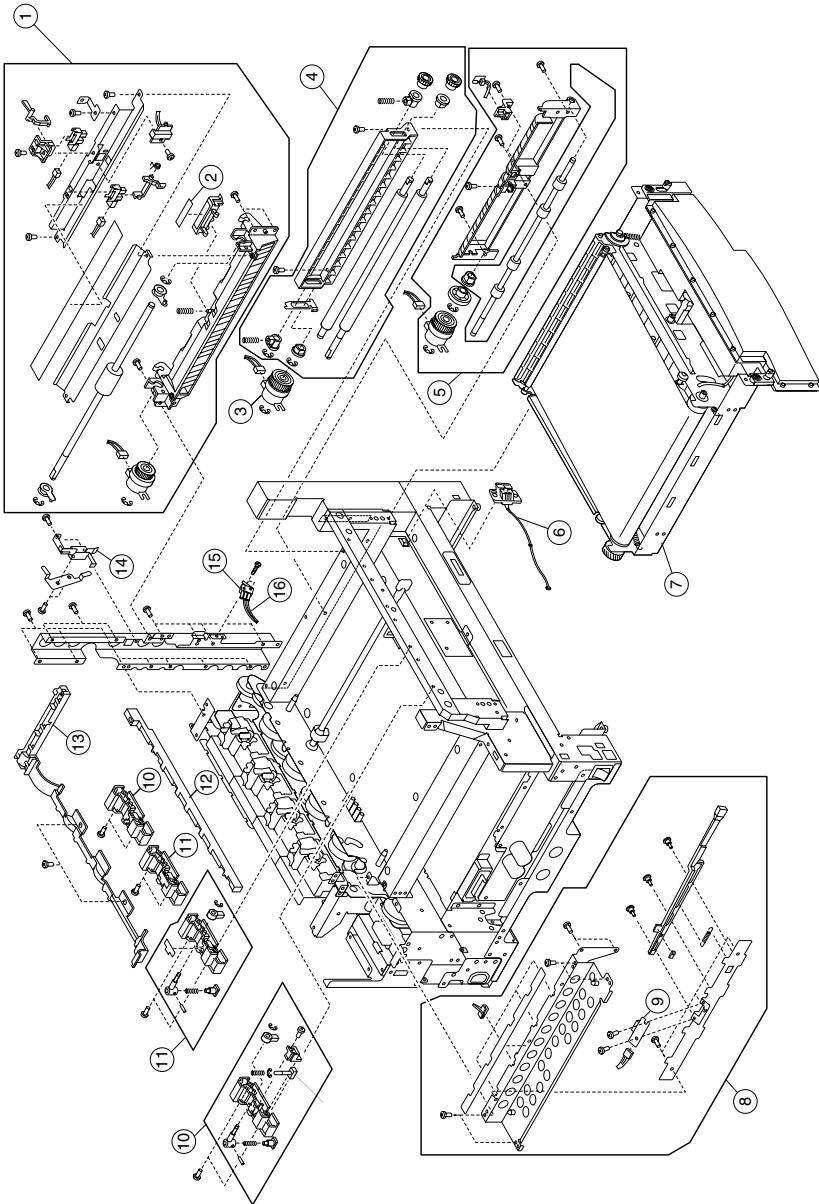

Assembly 9: Base 3

Index	P/N	Units	Description
9-1	56P9971	1	Frame assembly, MPF
2	11G0283	1	Pad, fanning
3	56P9681	1	Clutch, registration
4	56P9680	1	Frame assembly, registration
5	56P9682	1	Frame assembly, carrying
6	56P9696	1	Cable assembly, belt thermistor
7	56P9694	1	Unit, transfer belt
8	56P9674	1	Guide assembly, fuser entrance
9	56P9676	1	Sensor, density
10	56P9684	2	Frame assembly, F1 sub
11	56P9685	2	Frame assembly, F2 sub
12	56P9686	1	Rod, lock
13	56P9687	1	Cover, gear
14	56P9693	1	Stopper, clutch
15	56P9502	1	Sensor, turn guide door
16	56P9695	1	Cable, turn guide door sensor
NS	56P9697	1	Bushing
NS	56P9692	1	Cable assembly, reg MPF sensor
NS	56P9950	1	Parts packet

Assembly 10: Electrical

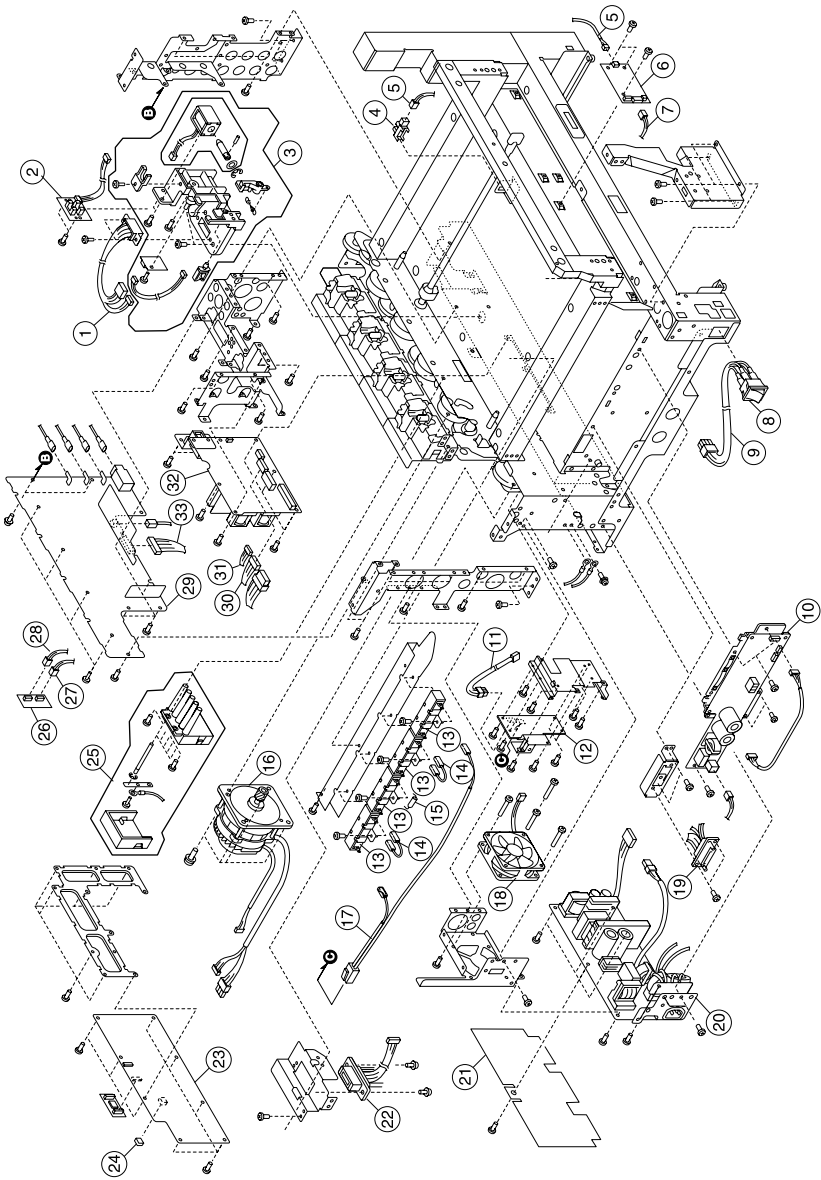

Assembly 10: Electrical

Index	P/N	Units	Description
10-1	56P9705	1	Cable assembly, feeder
2	56P9704	1	Cable assembly, paper remaining sensor
3	56P9700	1	Solenoid assembly, paper feed (temperature/humidity sensor and paper remaining sensor included)
4	11G0243	1	Interrupter, photo
5	56P9702	1	Cable, belt up/down sensor
6	56P9701	1	Board, sensor
7	56P9703	1	Cable assembly, sensor board
8	56P9707	1	Switch, power
9	56P9706	1	Cable, power switch
10	56P9709	1	Board, 120 V motor driver
10	56P9710	1	Board, 230 V motor driver
11	56P9739	1	Cable asm., conditioning printer controller
12	56P9742	1	Board, heater drive
13	56P9741	4	Resistor, conditioning (230 V only)
14	56P9738	3	Cable assembly, conditioning joint (230 V only)
15	56P9943	1	Fuse, thermal (230 V only)
16	56P9698	1	Motor assembly, 120 V
16	56P9699	1	Motor assembly, 230 V
17	56P9740	1	Cable, conditioning resistor
18	56P9713	1	Fan, power supply
19	56P9708	1	Cable assembly, duplex connector
20	56P9722	1	Power supply, 120 V (1)
20	56P9723	1	Power supply, 230 V (1)
21	56P9737	1	Insulator, sheet
22	56P9711	1	Cable, THB drawer
22	56P9712	1	Cable, THB drawer (EMEA)
23	56P9981	1	Board, printer controller (C910, C912)– S/N XX-0XXXXX
23	56P9992	1	Board, printer controller (C912)– S/N XX-1XXXXX
24	56P9729	1	EPROM, printer controller
25	56P9732	1	Belt, power supply

Assembly 10 (continued): Electrical

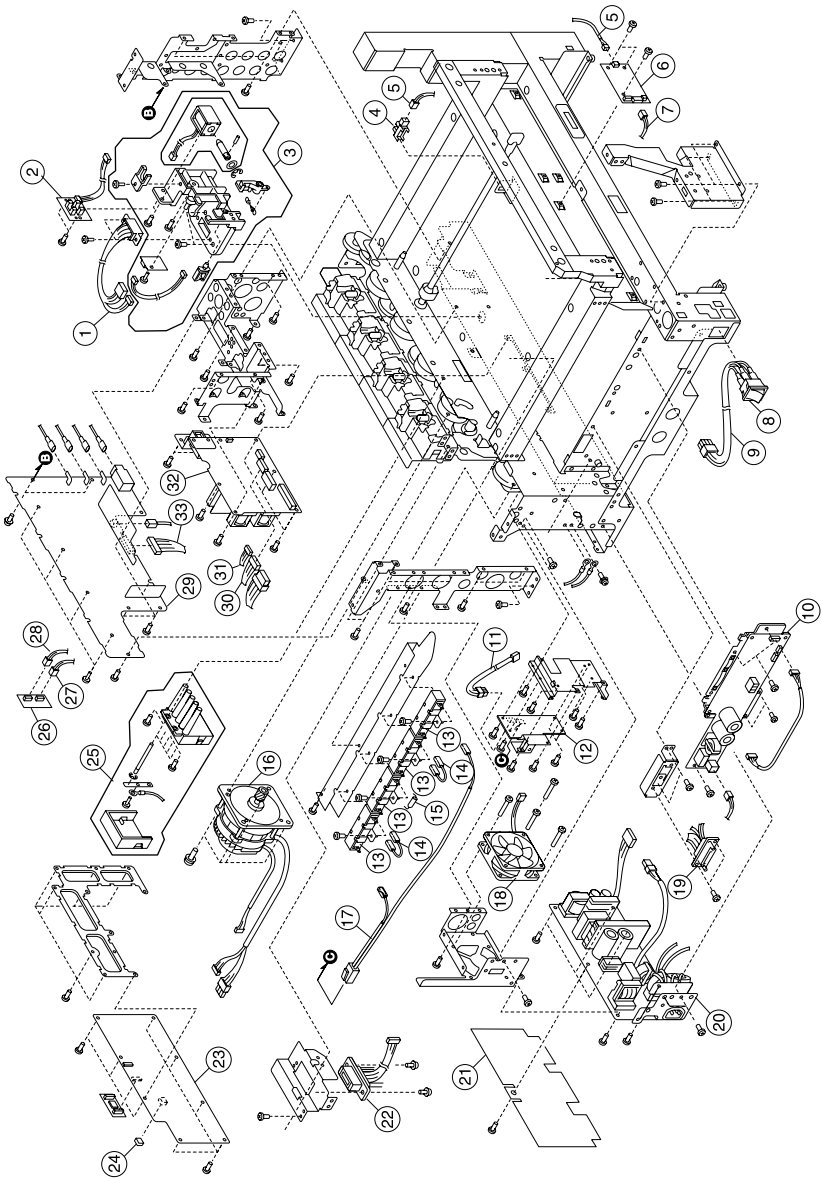

Assembly 10 (continued): Electrical

Index	P/N	Units	Description
10-26	56P9734	1	HCF/finisher D-sub assembly
27	56P9731	1	Cable assembly, finisher
28	56P9730	1	Cable assembly, HCF
29	56P9714	1	Board, high voltage power supply
30	56P9727	1	Cable assembly, printer controller power 2
31	56P9726	1	Cable assembly, printer controller power 1
32	56P9724	1	Power supply, 120 V (2)
32	56P9725	1	Power supply, 230 V (2)
33	56P9715	1	Cable high voltage power supply board
NS	11D0328	1	Power cord—USA, Canada, APG, LAD
NS	11D0329	1	Power cord—Peru
NS	11D0330	1	Power cord—Argentina
NS	11D0331	1	Power cord—Brazil
NS	11D0332	1	Power cord—Chile
NS	11D0333	1	Power cord—Denmark
NS	11D0334	1	Power cord—Belgium, Europe, England, France, Germany, Spain
NS	11D0335	1	Power cord—Italy
NS	11D0336	1	Power cord—Swiss/French, German, Italian
NS	11D0337	1	Power cord—UK, Israel, South Africa
NS	56P9951	1	Parts packet
NS	56P9733	1	Cable assembly, HCPF interface
NS	56P9721	1	Cable assembly, drum eraser
NS	56P9964	1	Transformer, power (Japan only)

Assembly 11: Rip board

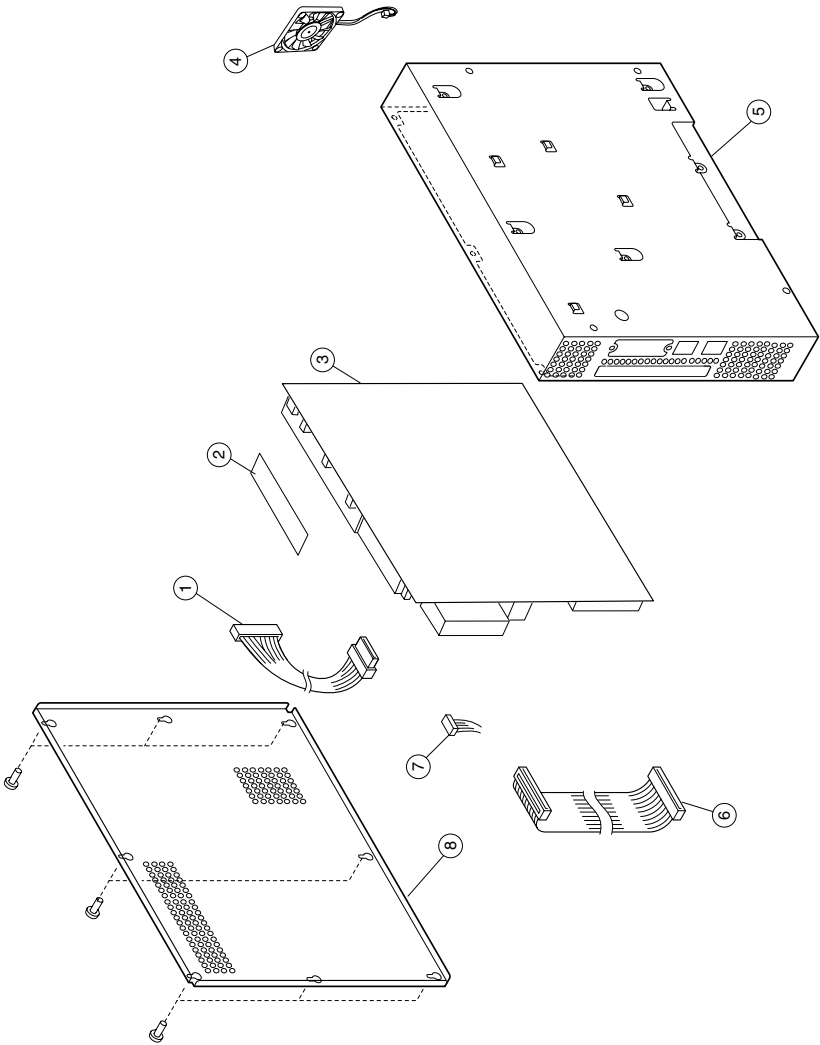

Assembly 11: RIP board

Index	P/N	Units	Description
11-1	56P9749	1	Cable assembly, power RIP
2	56P9916	1	Card, riser
3	56P9976	1	Board, RIP controller (C910)
3	56P9977	1	Board, RIP controller, network (C910)
3	56P9973	1	Board, RIP controller (C912)
3	56P9974	1	Board, RIP controller, network (C912)
4	56P9750	1	Fan, RIP
5	56P9745	1	Box, RIP
6	56P9719	1	Cable assembly, 80 pin RIP printer controller
7	56P9736	1	Cable, operator panel
8	56P9746	1	Cover, RIP box
NS	56P9747	1	Cable assembly, power MAC
NS	56P9748	1	Cable assembly, MIF
NS	56P9952	1	Parts packet

Assembly 12: Fuser unit

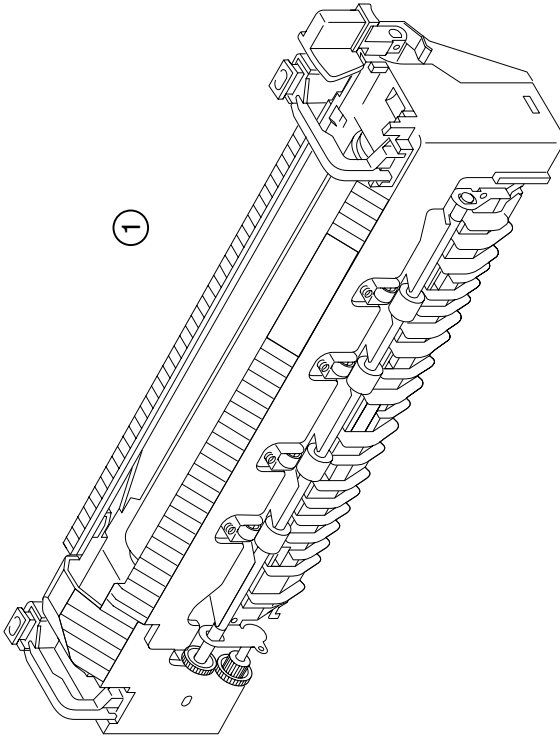

Assembly 12: Fuser unit

Index	P/N	Units	Description
12-1	56P9751	1	Fuser, 120 V
1	56P9752	1	Fuser, 230 V
NS	56P9953	1	Parts packet

Assembly 13: Cassette

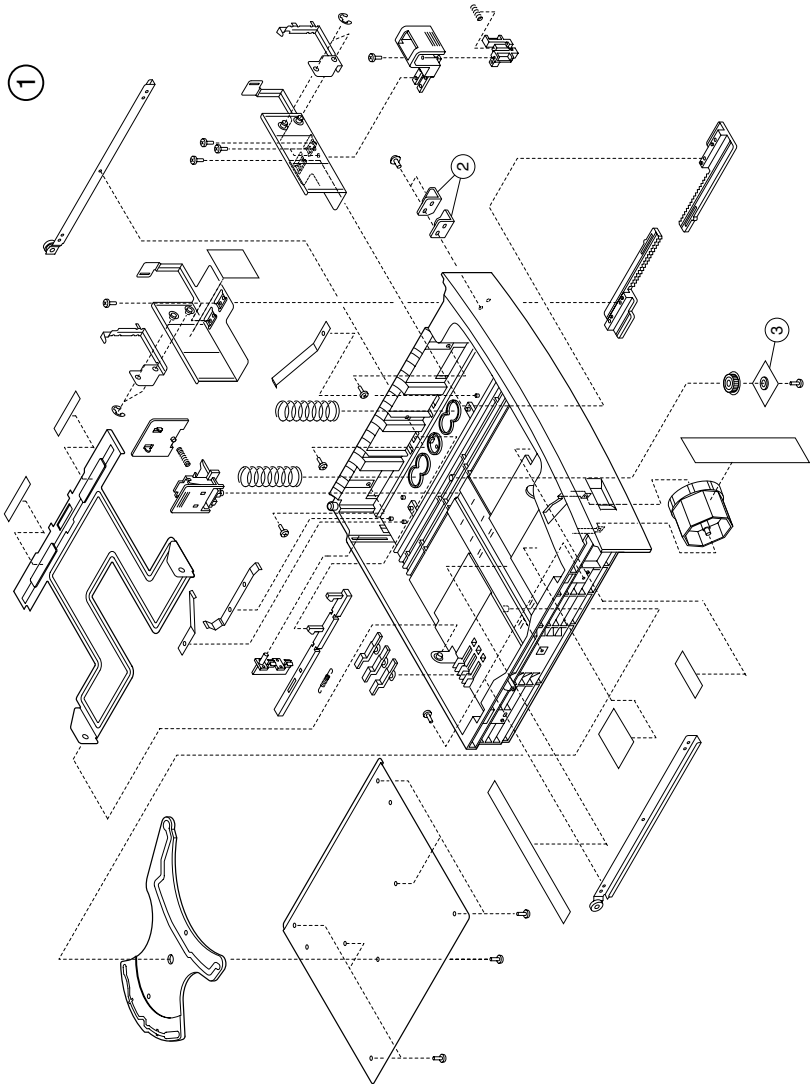

Assembly 13: Cassette

Index	P/N	Units	Description
13-1	56P9500	1	Cassette, paper feed
NS	56P9902	1	Cassette, heavy media
2	56P9979	1	Guide, stop
3	56P9980	1	Guard, rack

Assembly 14: Expansion feeder 1

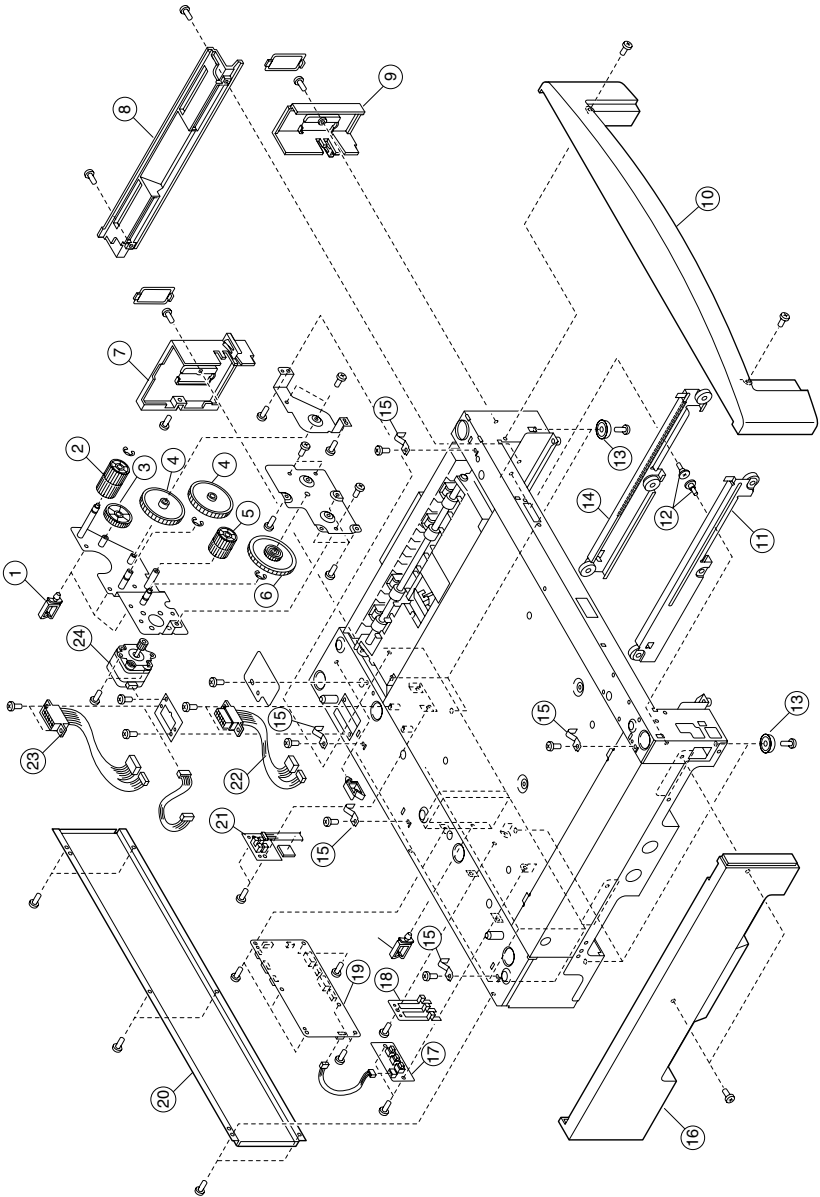

Assembly 14: Expansion feeder 1

Index	P/N	Units	Description
14-1	11G0199	4	Guide, wire
2	56P9773	1	Gear, feeder E
3	56P9771	1	Gear, feeder C
4	11G0422	2	Gear, feeder B
5	56P9772	1	Gear, feeder D
6	11G0423	1	Gear, feeder A
7	56P9770	1	Cover, right side C
8	56P9769	1	Cover, right side B
9	56P9767	1	Cover, right side A
10	56P9765	1	Cover, front feeder
11	56P9504	1	Rail, left side
12	56P9524	2	Screw, slide rail
13	56P9503	6	Foot, rubber
14	56P9505	1	Rail, right side
15	11G0399	5	Plate, ground
16	56P9766	1	Cover, left side
17	56P9522	1	Board, size sensor
18	56P9521	1	Lever, size sensor
19	56P9779	1	Board, expansion feeder control
20	56P9768	1	Cover, rear
21	56P9776	1	Board, paper remaining sensor
22	56P9778	1	Cable assembly, lower optional drawer
23	56P9777	1	Cable assembly, upper optional drawer
24	56P9774	1	Motor, feeder drive
NS	56P9775	1	Cable assembly, size sensor
NS	56P9955	1	Parts packet

Assembly 15: Expansion feeder 2

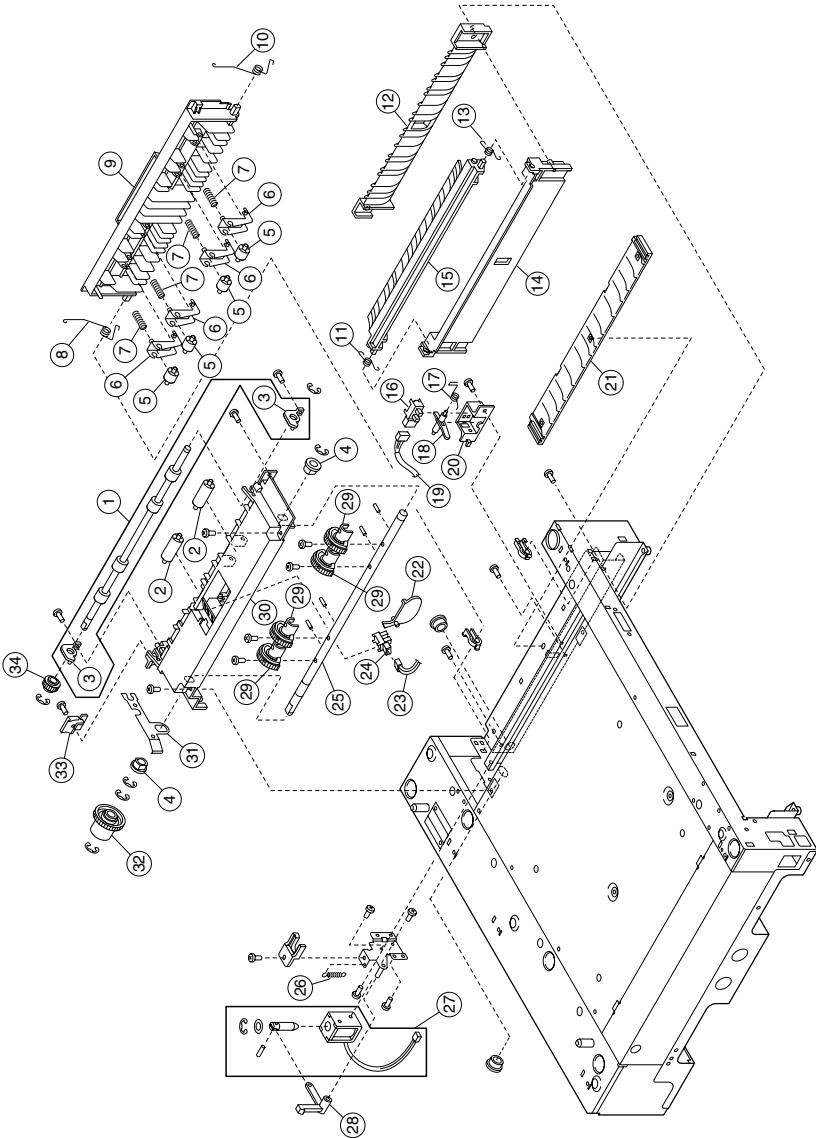

Assembly 15: Expansion feeder 2

Index	P/N	Units	Description
15-1	56P9796	1	Roller assembly, carrying
2	56P9514	2	Roller, noise reduction
3	56P9513	2	Bushing, carrying
4	56P9509	2	Bushing, metal
5	56P9790	4	Roller, paper carrying
6	56P9792	4	Holder, roller
7	56P9791	4	Spring, paper carrying
8	56P9794	1	Spring, right turn guide
9	56P9789	1	Guide, turn
10	56P9793	1	Spring, left turn guide
11	56P9517	1	Spring, right cassette guide
12	56P9519	1	Guide, lower right cassette
13	56P9516	1	Spring, left cassette guide
14	56P9518	1	Guide, lower left cassette
15	56P9515	1	Guide, upper cassette
16	11G0563	1	Interrupter, photo
17	56P9786	1	Spring, paper detection sensor
18	56P9784	1	Actuator, paper detection
19	56P9787	1	Cable, paper present sensor
20	56P9785	1	Cover, paper present sensor
21	56P9788	1	Guide, HCF
22	56P9507	1	Actuator, paper feed sensor
23	56P9795	1	Cable, paper present sensor
24	11G0219	1	Interrupter, photo
25	56P9510	1	Shaft, paper feed
26	56P9782	1	Spring, solenoid
27	56P9783	1	Solenoid, feeder
28	56P9781	1	Lever, clutch
29	56P9511	4	Roller assembly, paper feed
30	56P9506	1	Frame, paper feed
31	56P9508	1	Bracket, ground
32	11G0291	1	Clutch, paper feed
33	56P9797	1	Cover, gear
34	11G0297	1	Gear, paper carrying

Assembly 15 (continued): Expansion feeder 2

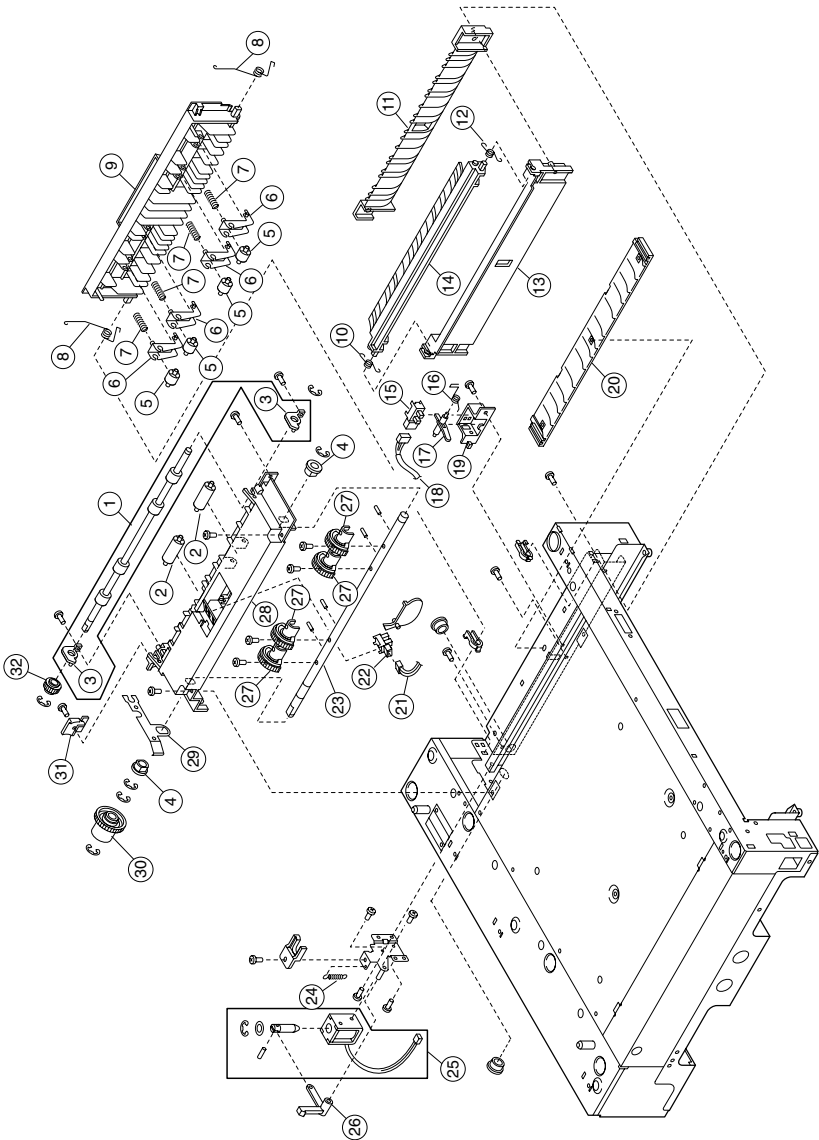

Assembly 15 (continued): Expansion feeder 2

Index	P/N	Units	Description
NS	56P9956	1	Parts packet

Assembly 16: Duplex unit 1

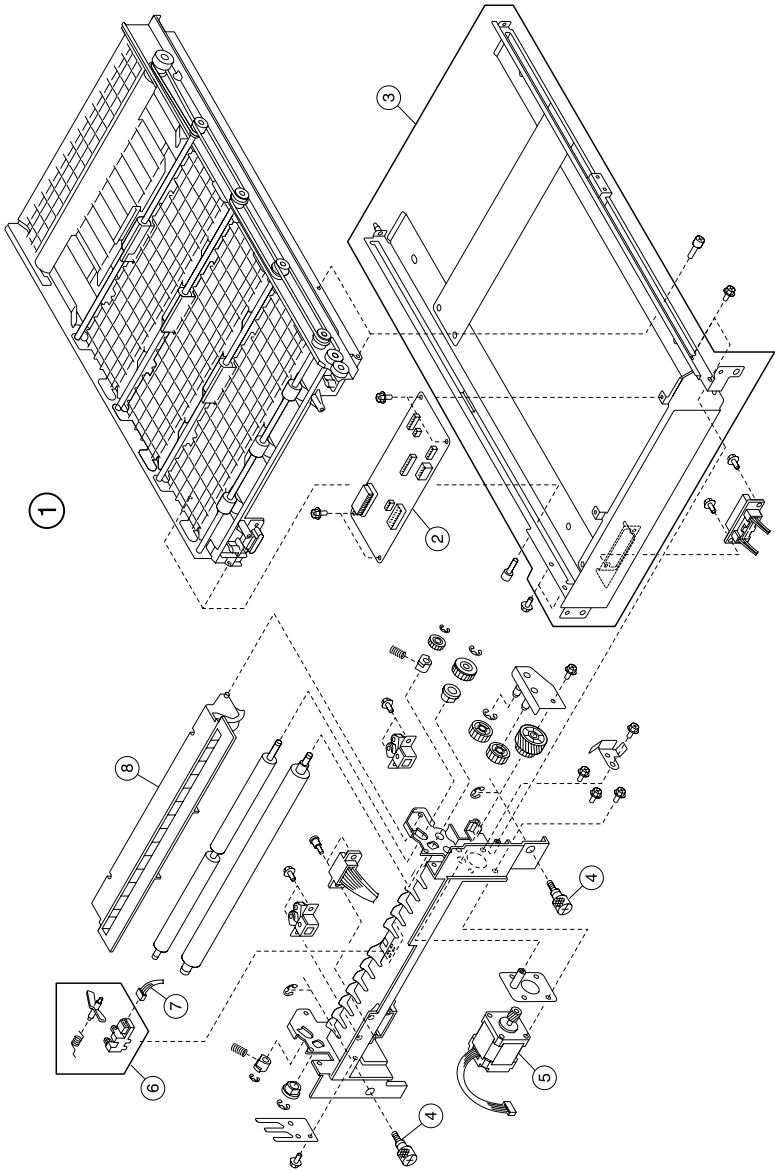

Assembly 16: Duplex unit 1

Index	P/N	Units	Description
16-1	56P9798	1	Duplex assembly
2	56P9804	1	Board, duplex interface
3	56P9799	1	Frame, duplex
4	56P9800	2	Screw, duplex mounting
5	56P9803	1	Motor, duplex stepping
6	56P9525	1	Interrupter, photo
7	56P9806	1	Cable assembly, paper detection
8	56P9994	1	Plate, duplex guide
NS	56P9807	1	Cable assembly, duplex interface
NS	56P9805	1	Cable assembly, duplex connection

Assembly 17: Duplex unit 2

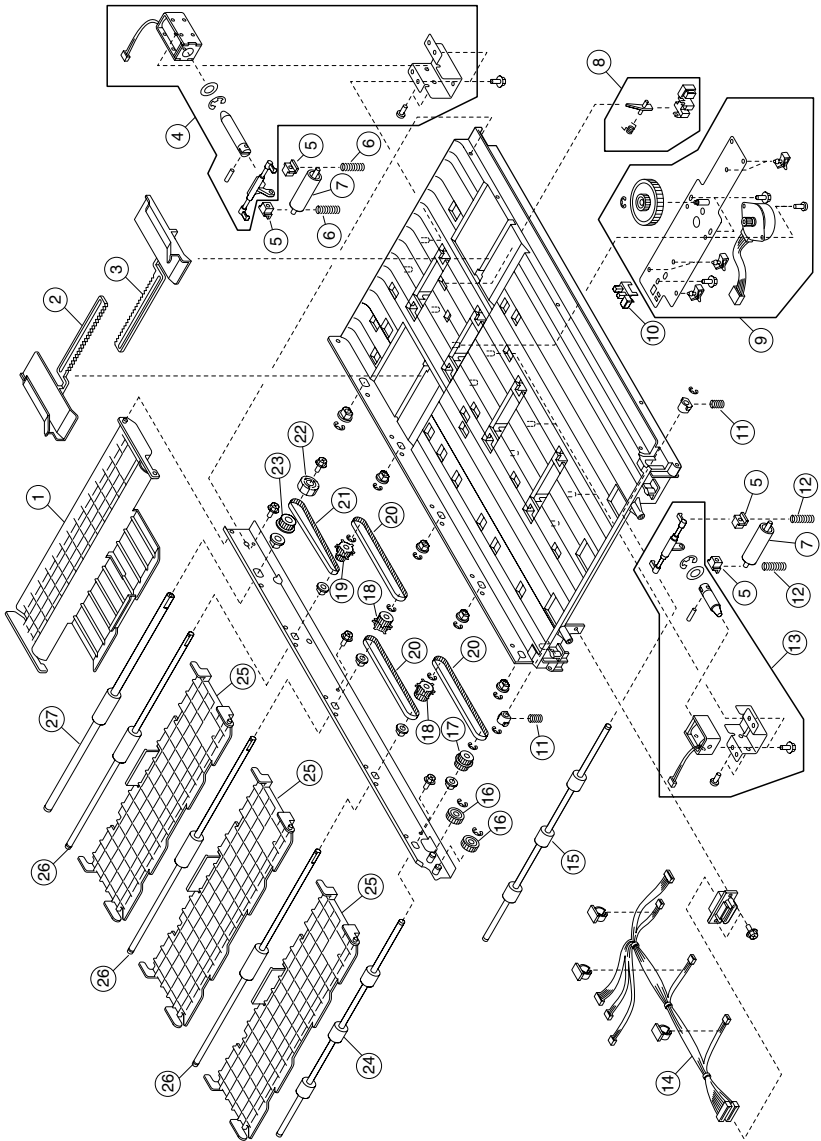

Assembly 17: Duplex unit 2

Index	P/N	Units	Description
17-1	56P9825	1	Plate, paper re-feed drawer
2	56P9827	1	Guide, rear side
3	56P9826	1	Guide, front side
4	56P9830	1	Solenoid assembly, paper re-feed
5	56P9814	8	Bearing, release
6	56P9816	2	Spring, re-feed roller
7	56P9813	4	Roll, release
8	56P9525	1	Interrupter assembly, photo
9	56P9828	1	Motor assembly, paper guide
10	56P9808	1	Interrupter, photo
11	56P9526	2	Spring, feed roller
12	56P9815	6	Spring, reed roller
13	56P9829	3	Solenoid assembly, feed roller
14	56P9831	1	Cable assembly, duplex drawer
15	56P9810	1	Roller, follow-up feed
16	56P9527	2	Gear, idler
17	56P9817	1	Gear, carrying roller
18	56P9818	2	Pulley, carrying roller timing
19	56P9819	1	Pulley, feed roller
20	56P9822	3	Belt, timing
21	56P9823	1	Belt, timing
22	56P9821	1	Knob, paper re-feed
23	56P9820	1	Pulley, re-feed roller
24	56P9809	1	Roller, drive feed
25	56P9824	3	Plate, paper carrying drawer
26	56P9811	3	Roller, middle feed
27	56P9812	1	Roller, re-feed
NS	56P9957	1	Parts packet

Assembly 18: High-capacity feeder 1

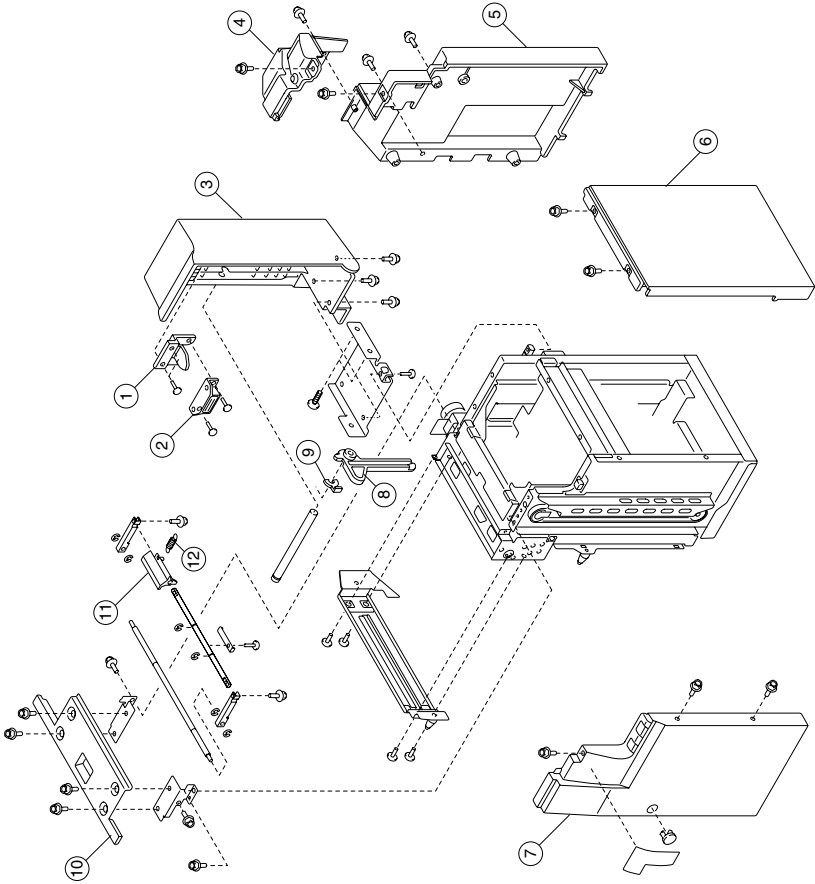

Assembly 18: High-capacity feeder 1

Index	P/N	Units	Description
18-1	56P9838	1	Catch, door
2	56P9835	1	Magnet, latch
3	56P9837	1	Cover, upper
4	56P9834	1	Cover, upper rear
5	56P9843	1	Cover, lower rear
6	56P9839	1	Cover, right
7	56P9833	1	Cover, front
8	56P9836	1	Fence, end
9	56P9940	1	Ring, snap
10	56P9841	1	Cover assembly, upper
11	56P9840	1	Lever, vertical transport
12	56P9842	1	Spring, tension
NS	56P9958	1	Parts packet

Assembly 19: High-capacity feeder 2

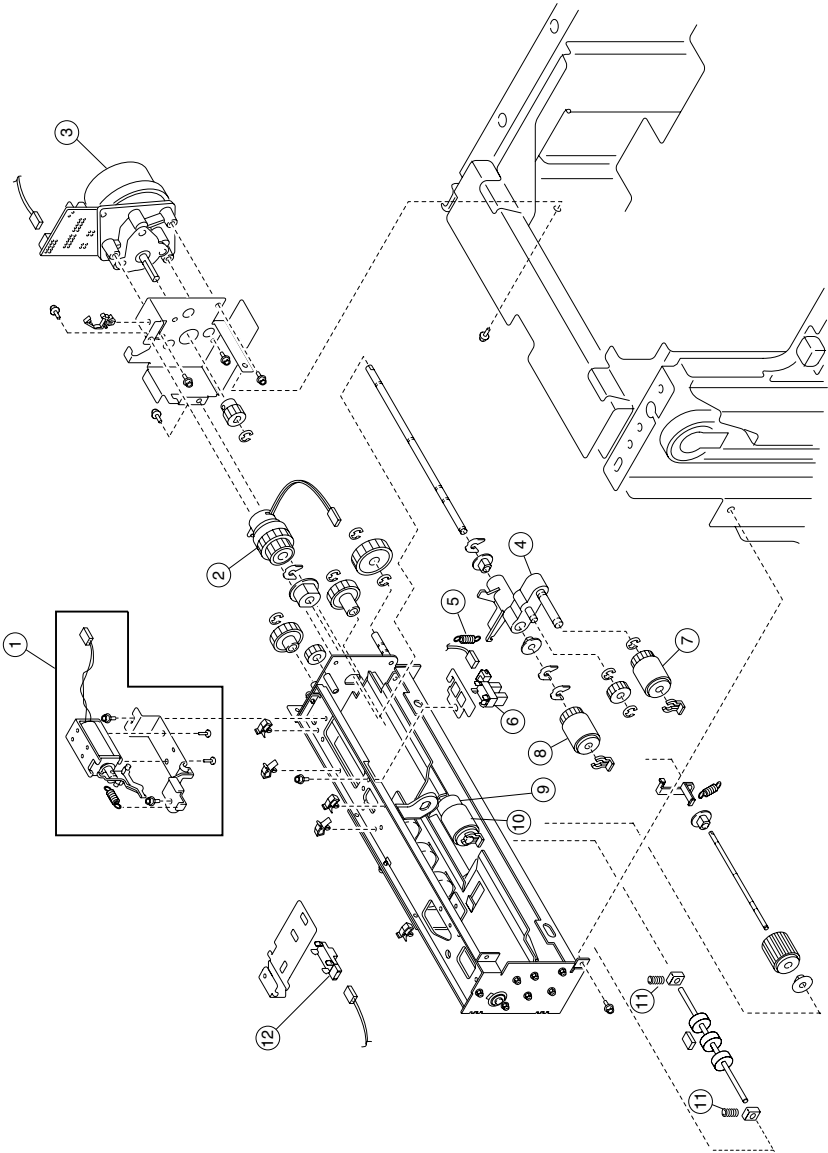

Assembly 19: High-capacity feeder 2

Index	P/N	Units	Description
19-1	56P9846	1	Solenoid assembly, paper pickup
2	56P9848	1	Clutch, paper feed
3	56P9844	1	Motor assembly, transport
4	56P9941	1	Arm, pick-up
5	56P9501	1	Spring, pressure
6	56P9528	1	Interrupter, photo
7	56P9849	1	Roller, manual feed pickup
8	56P9850	1	Roller, manual feed
9	56P9852	1	Limiter, torque
10	56P9851	1	Roller, manual feed separate
11	56P9847	2	Spring, compression
12	56P9845	1	Sensor assembly, paper feed
NS	56P9959	1	Parts packet

Assembly 20: High-capacity feeder 3

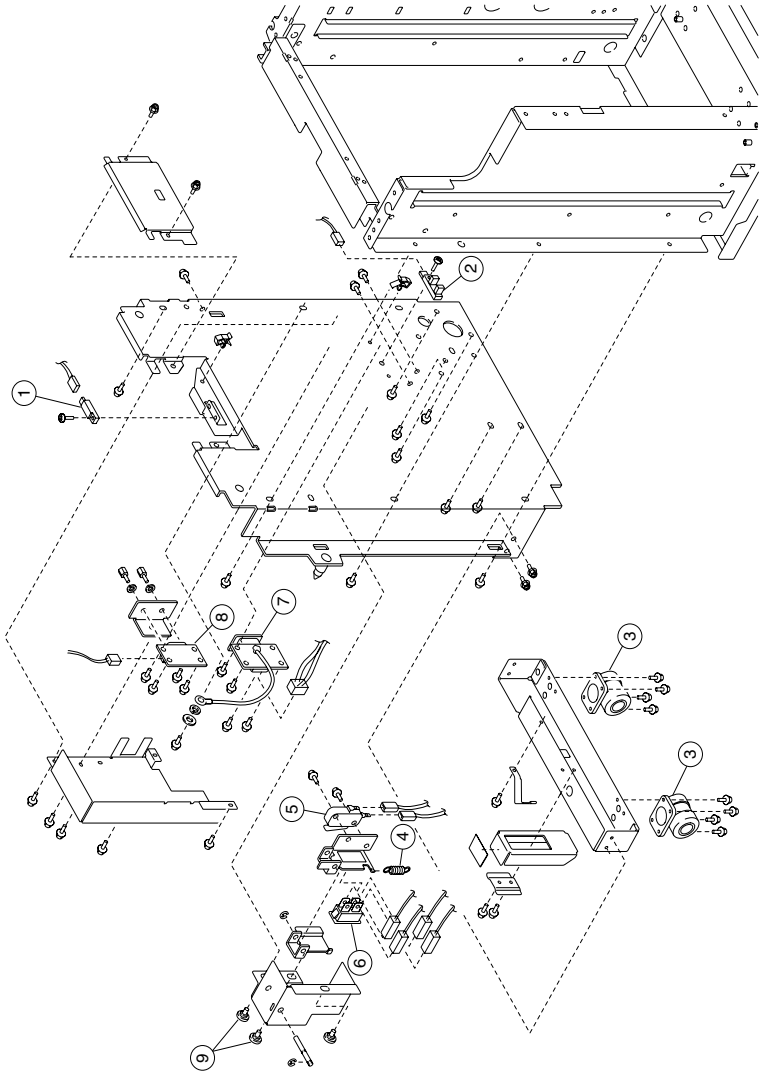

Assembly 20: High-capacity feeder 3

Index	P/N	Units	Description
20-1	56P9854	1	Sensor assembly, photo
2	56P9855	1	Interrupter, photo
3	56P9529	4	Caster, HCF
4	56P9856	1	Spring, tension
5	56P9857	1	Switch, micro
6	56P9530	1	Switch, push
7	56P9859	1	Connector, inlet
8	56P9858	1	Connector, I/F
9	56P9853	3	Screw, shoulder
NS	56P9960	1	Parts packet

Assembly 21: High-capacity feeder 4

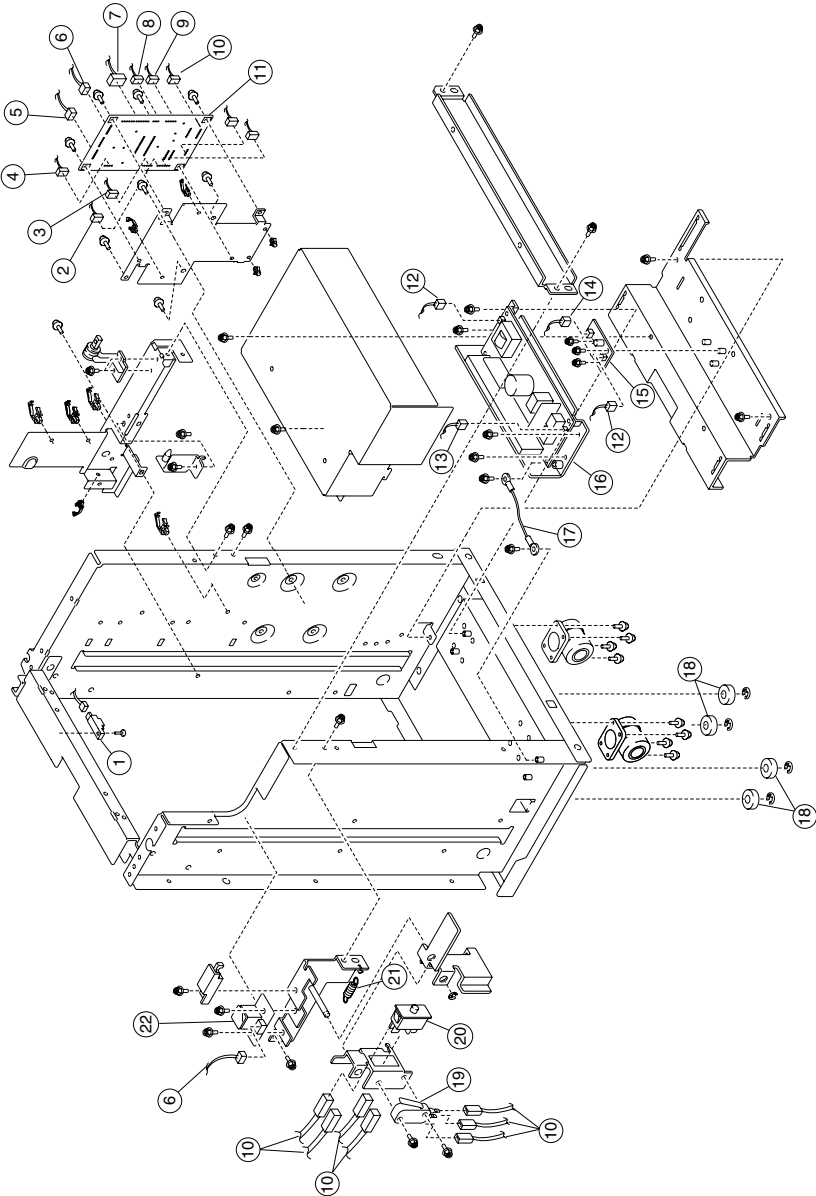

Assembly 21: High-capacity feeder 4

Index	P/N	Units	Description
21-1	56P9541	1	Sensor, resistor
2	56P9875	1	Cable assembly, safety switch
3	56P9865	1	Cable assembly, HCF motor
4	56P9871	1	Cable assembly, I/F
5	56P9866	1	Cable assembly, paper feed sensor
6	56P9880	1	Cable, up/down switch
7	56P9879	1	Cable, paper volume
8	56P9878	1	Cable assembly, sensor
9	56P9877	1	Cable assembly, paper size sensor
10	56P9876	1	Cable assembly, lift motor
11	56P9868	1	Board, high-capacity feed
12	56P9873	1	Cable assembly, power supply out
13	56P9872	1	Cable assembly, power supply in
14	56P9874	1	Cable assembly, power supply
15	56P9870	1	Converter, DC/DC
16	56P9869	1	Power supply, HCF
17	56P9867	1	Cable assembly, drawer ground
18	56P9861	4	Roller, track
19	56P9864	1	Switch, micro
20	56P9530	1	Switch, push
21	56P9501	1	Spring, pressure pickup
22	56P9863	1	Switch, HCF push
NS	56P9961	1	Parts packet

Assembly 22: High-capacity feeder 5

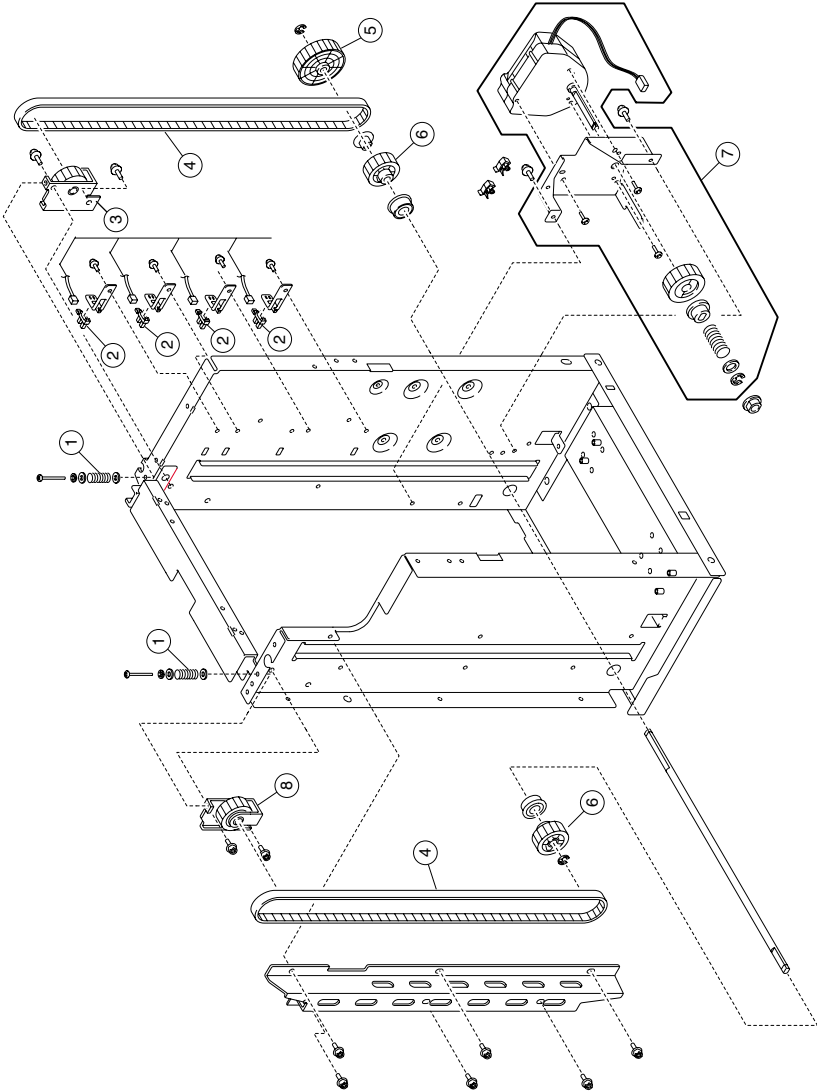

Assembly 22: High-capacity feeder 5

Index	P/N	Units	Description
22-1	56P9883	2	Spring, pressure
2	56P9528	4	Interrupter, photo
3	56P9888	1	Bracket, rear idler
4	56P9884	2	Belt, timing
5	56P9886	1	Gear, drive
6	56P9885	2	Pulley, timing
7	56P9882	1	Motor, HCF DC
8	56P9887	1	Bracket, front idler
NS	56P9962	1	Parts packet

Assembly 23: High-capacity feeder 6

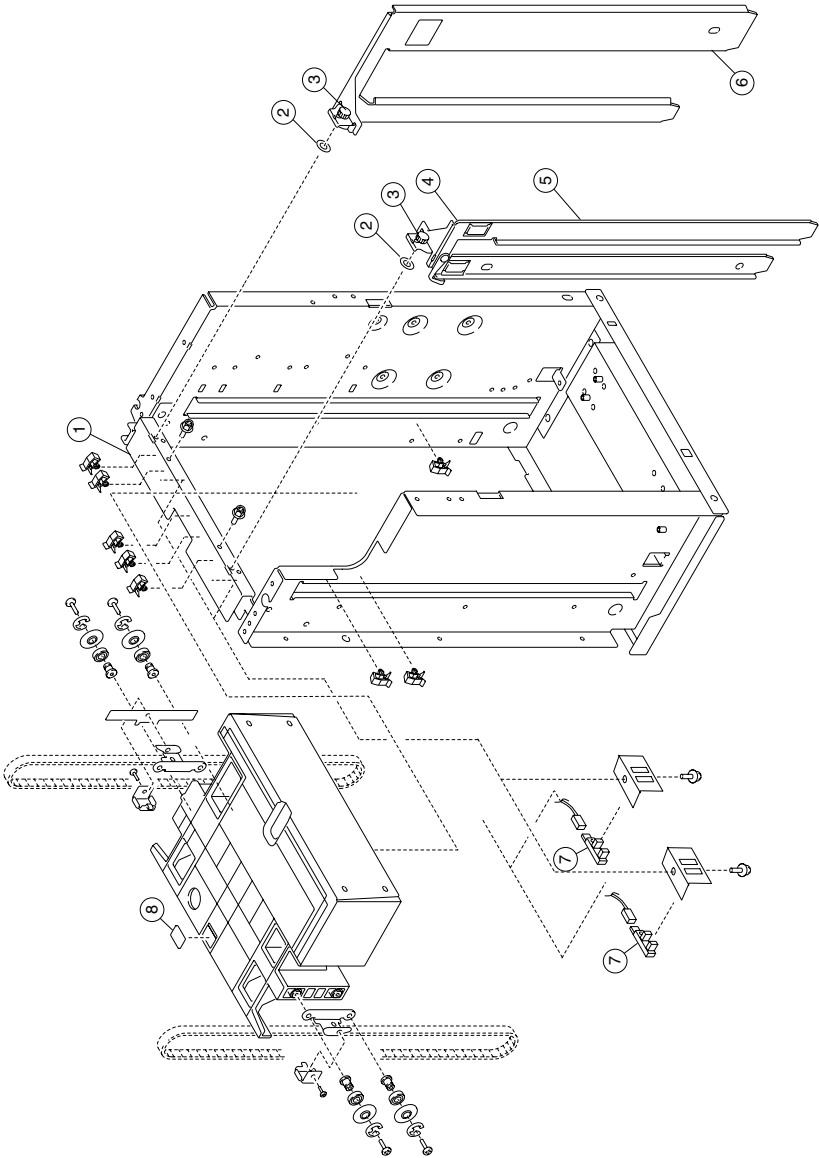

Assembly 23: High-capacity feeder 6

Index	P/N	Units	Description
23-1	56P9892	1	Plate, upper side fence
2	56P9893	2	Knob, stopper
3	56P9891	2	Knob, tray
4	56P9890	2	Plate, paper adhesion
5	56P9915	1	Fence assembly, front side
6	56P9894	1	Fence assembly, rear side
7	56P9528	2	Interrupter, photo
8	56P9889	1	Pad, friction
NS	56P9963	1	Parts packet

Assembly 24: Finisher covers

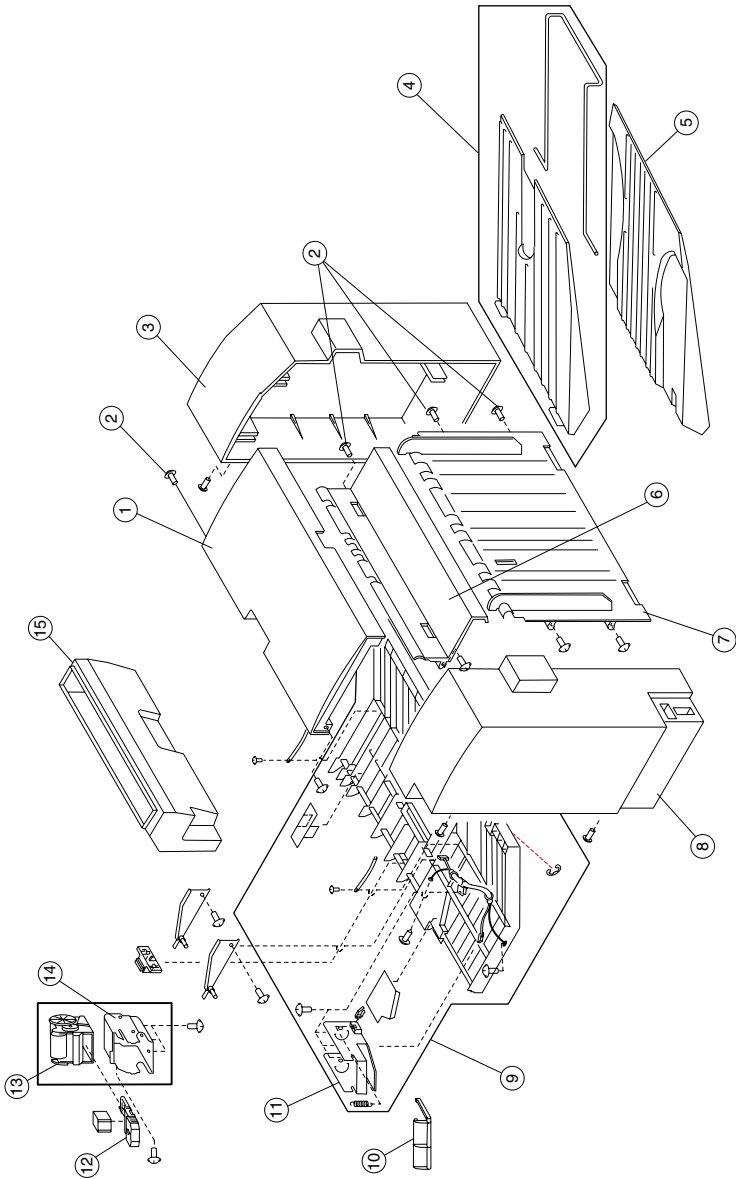

Assembly 24: Finisher covers

Index	P/N	Units	Description
24-1	56P9353	1	Cover, top
2	56P9348	5	Screw, A
3	56P9355	1	Cover, front
4	56P9359	1	Tray, upper
5	56P9360	1	Tray, lower
6	56P9347	1	Panel, left upper
7	56P9352	1	Assembly, lower left panel
8	56P9356	1	Cover, rear
9	56P9350	1	Assembly, staple cover
10	56P9366	1	Lever, B
11	56P9365	1	Cover, staple A
12	56P9367	1	Cartridge, staple
13	56P9363	1	Stapler
14	56P9364	1	Cover, staple B
15	56P9354	1	Assembly, dust box

Assembly 25: Finisher frame

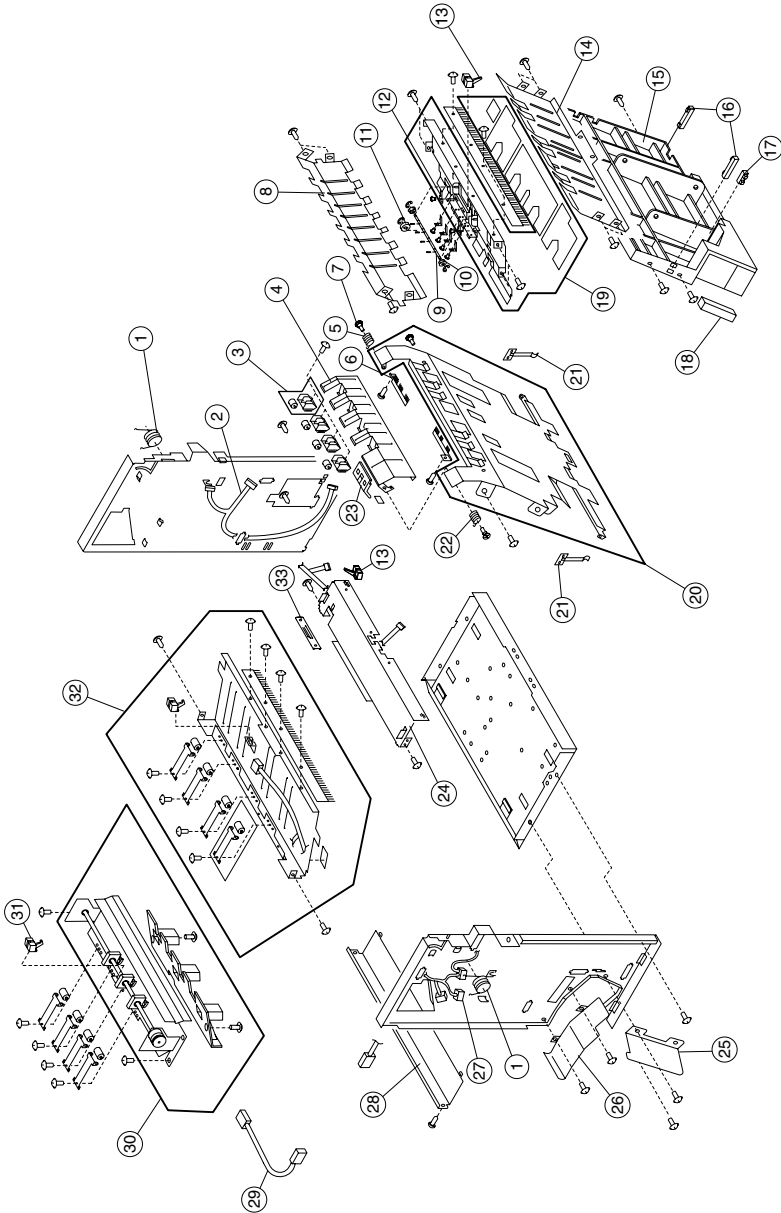

Assembly 25: Finisher frame

Index	P/N	Units	Description
25-1	56P9321	2	Spring, I
2	56P9324	1	Cable, sensor relay
3	56P9369	12	Assembly, spring plate C
4	56P9370	1	Frame, guide
5	56P9371	1	Spring
6	56P9372	1	Brush, static discharge
7	56P9373	2	Screw, M4
8	56P9374	2	Frame, C guide
9	56P9375	1	Shaft, D
10	56P9376	1	Bushing
11	56P9377	1	Roller, D
12	56P9378	1	Plate, E spring
13	56P9380	2	Sensor, photo
14	56P9381	1	Frame, B guide
15	56P9418	1	Guide, stack
16	56P9399	2	Sensor, photo
17	56P9382	1	Sensor, photo
18	56P9383	1	Cushion
19	56P9309	1	Assembly, exit guide inverter
20	56P9302	1	Assembly, center guide
21	56P9384	2	Plate, B spring
22	56P9386	1	Spring
23	56P9387	1	Handle, jam
24	56P9389	1	Bracket
25	56P9345	1	Cover, staple inner B
26	56P9344	1	Cover, staple inner A
27	56P9327	1	Cable, upper side panel
28	56P9390	1	Plate, cover
29	56P9436	1	Cable
30	56P9313	1	Unit, 3 hole punch (U.S. only)
30	56P9314	1	Unit, 4 hole punch (non U.S.)
31	56P9388	1	Sensor, 1 photo
32	56P9319	1	Assembly, exit guide straight
33	56P9394	1	Handle

Assembly 26: Finisher feed 1

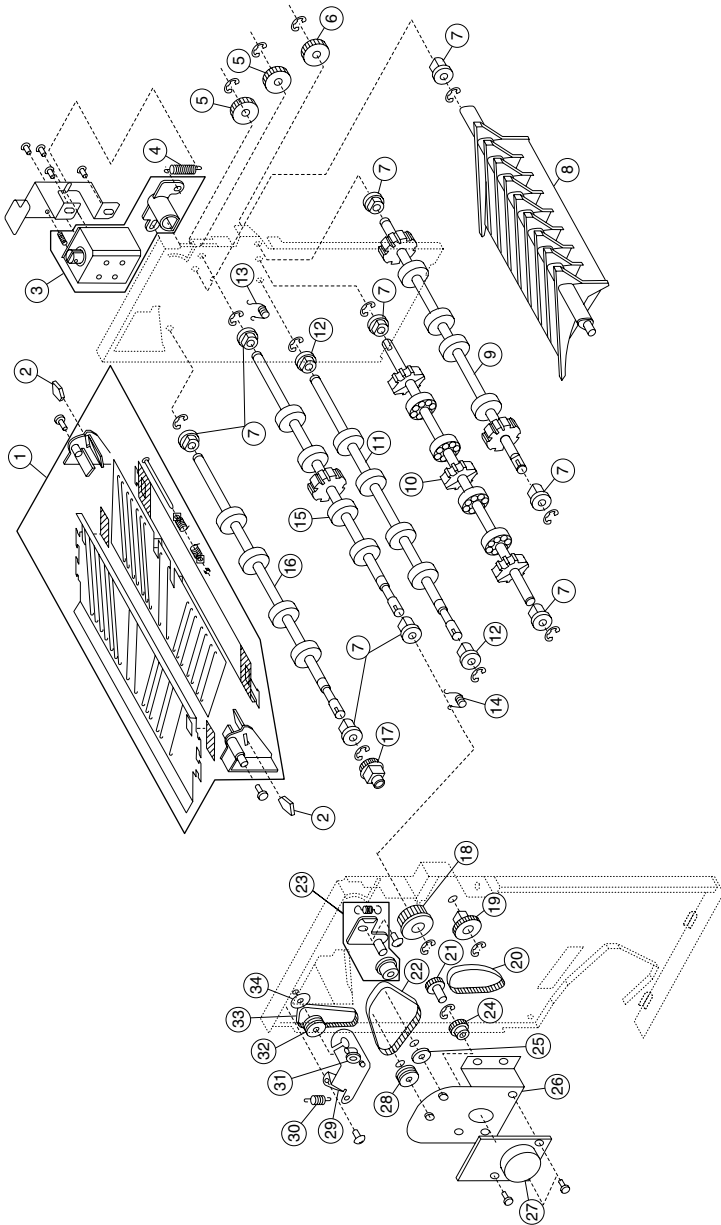

Assembly 26: Finisher feed 1

Index	P/N	Units	Description
26-1	56P9395	1	Assembly, guide plate
2	56P9393	2	Plate, guide holder
3	56P9334	1	Assembly, solenoid
4	56P9396	1	Spring, H
5	56P9397	2	Gear, Z20
6	56P9398	1	Gear, Z19
7	56P9311	9	Bushing
8	56P9310	1	Gate
9	56P9400	1	Roller
10	56P9361	1	Roller, patting
11	56P9401	1	Roller, I
12	56P9402	2	Bushing
13	56P9403	1	Spring, A
14	56P9404	1	Spring, F
15	56P9312	1	Roller, F
16	56P9405	1	Roller, G
17	56P9335	1	Clutch, registration
18	56P9338	1	Pulley, T56
19	56P9406	1	Pulley, Z24/T42 gear
20	56P9407	1	Belt, timing 60S2M184
21	56P9408	1	Knob
22	56P9339	1	Belt, timing 60S2M334
23	56P9305	1	Assembly, tension D
24	56P9411	1	Pulley
25	56P9412	1	Spacer
26	56P9413	1	Assembly, motor bracket
27	56P9341	1	Assembly, feed motor
28	56P9414	1	Pulley
29	56P9315	1	Assembly, punch drive
30	56P9318	1	Spring, B

Assembly 26 (continued): Finisher feed 1

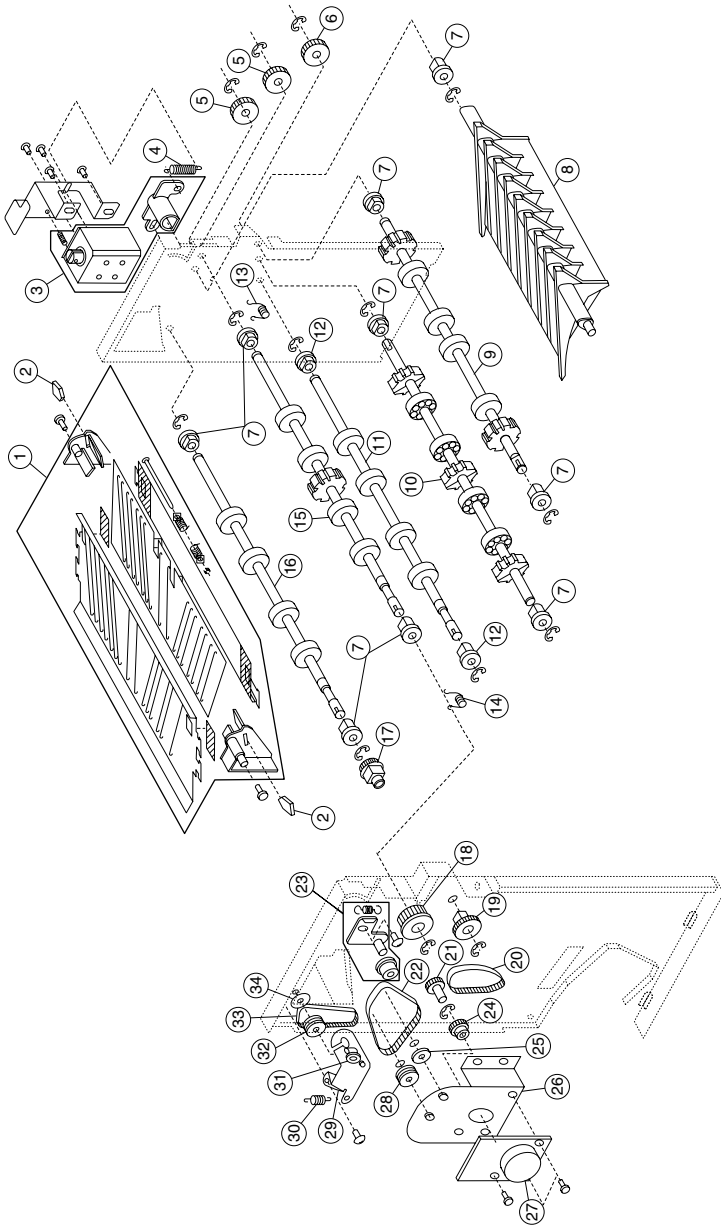

Assembly 26 (continued): Finisher feed 1

Index	P/N	Units	Description
26-31	56P9316	1	Bushing
32	56P9415	1	Pulley, gear Z36/T24
33	56P9317	1	Belt
34	56P9417	1	Flange

Assembly 27: Finisher feed 2

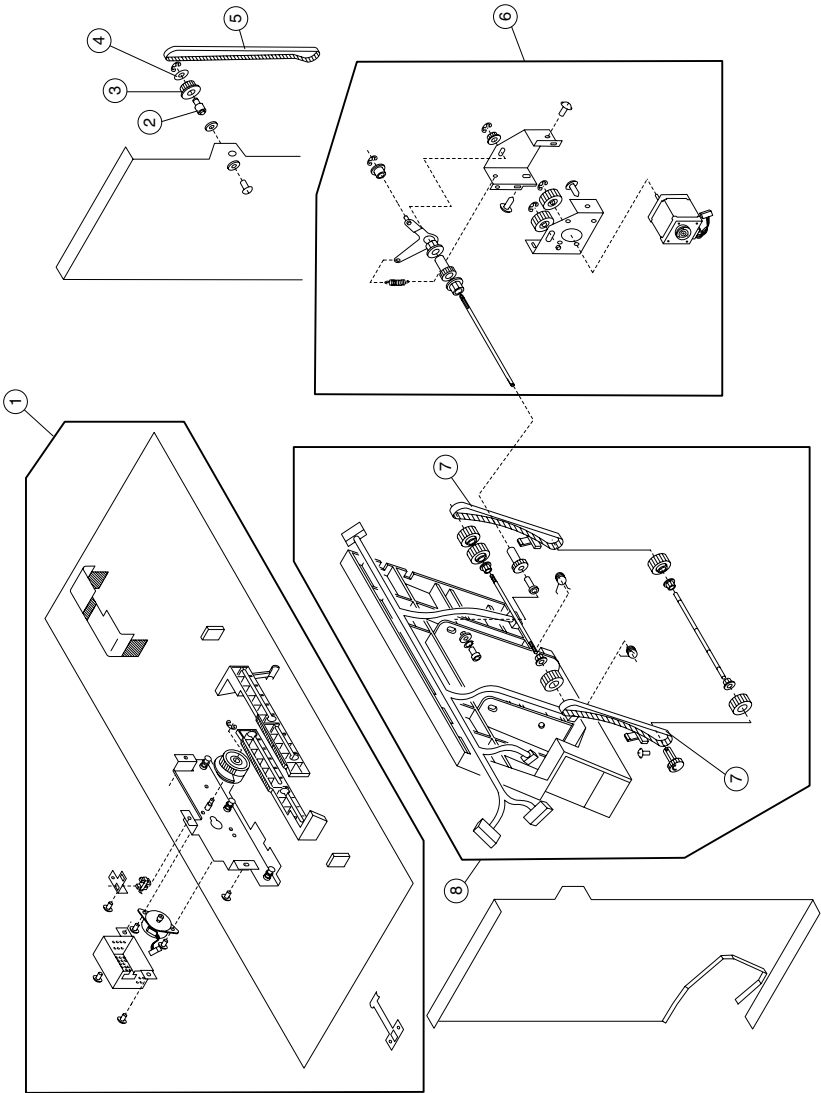

Assembly 27: Finisher feed 2

Index	P/N	Units	Description
27-1	56P9300	1	Assembly, jogging unit
2	56P9422	1	Pin, N
3	56P9423	1	Pulley, Z19/Z20
4	56P9417	1	Flange
5	56P9333	1	Belt, timing (60S3M408)
6	56P9329	1	Assembly, tractor motor
7	56P9437	2	Belt, timing
8	56P9301	1	Assembly, guide stack

Assembly 28: Finisher elevator

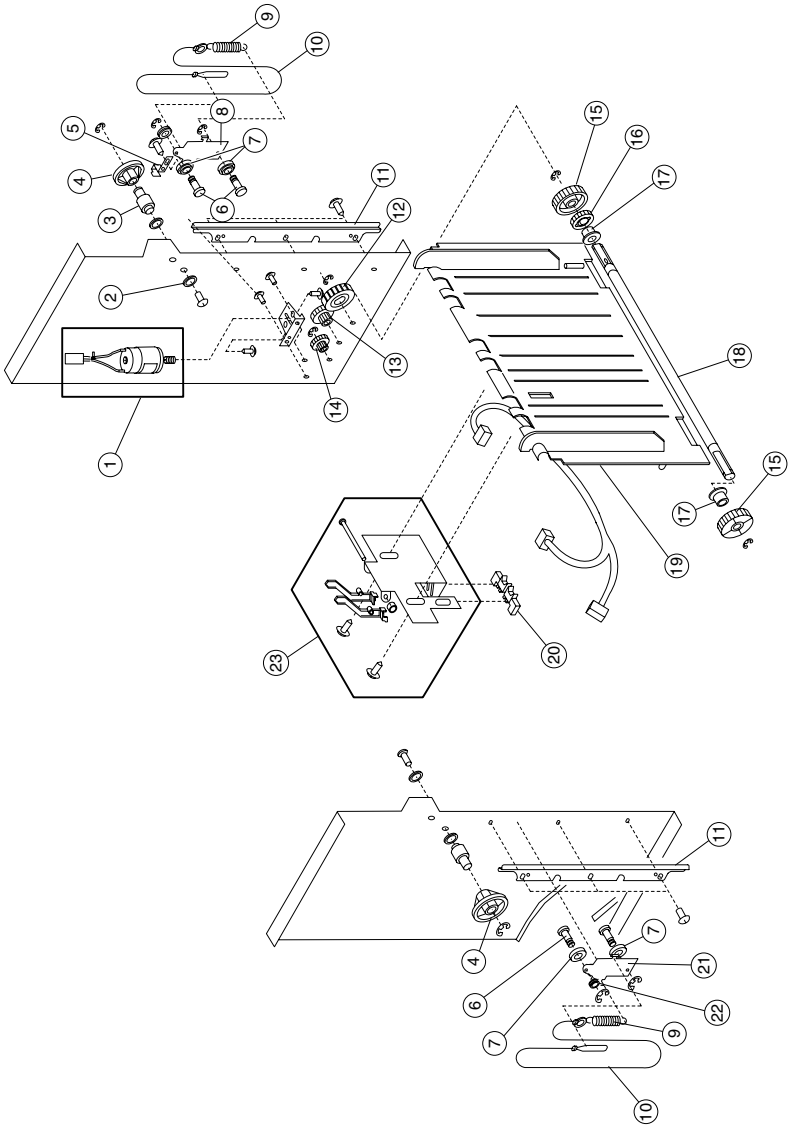

Assembly 28: Finisher elevator

Index	P/N	Units	Description
28-1	56P9308	1	Assembly, elevator motor
2	56P9448	1	Washer
3	56P9449	1	Pin
4	56P9450	2	Pulley, wire A
5	56P9451	1	Shutter
6	56P9452	1	Pin, O
7	56P9453	4	Roller, C
8	56P9304	1	Assembly, hook front
9	56P9332	2	Spring, C
10	56P9331	2	Wire
11	56P9455	2	Bracket
12	56P9456	1	Gear, Z46/Z33
13	56P9457	1	Gear, Z90/Z14
14	56P9458	1	Gear, Z25/Z20
15	56P9459	2	Drum, wire
16	56P9460	1	Gear, Z30
17	56P9311	2	Bushing
18	56P9482	1	Shaft, A
19	56P9352	1	Panel, lower left
20	56P9382	1	Sensor
21	56P9307	1	Assembly, hook rear
22	56P9463	2	Pulley, wire B
23	56P9465	1	Assembly, sensor

Assembly 29: Finisher electronics

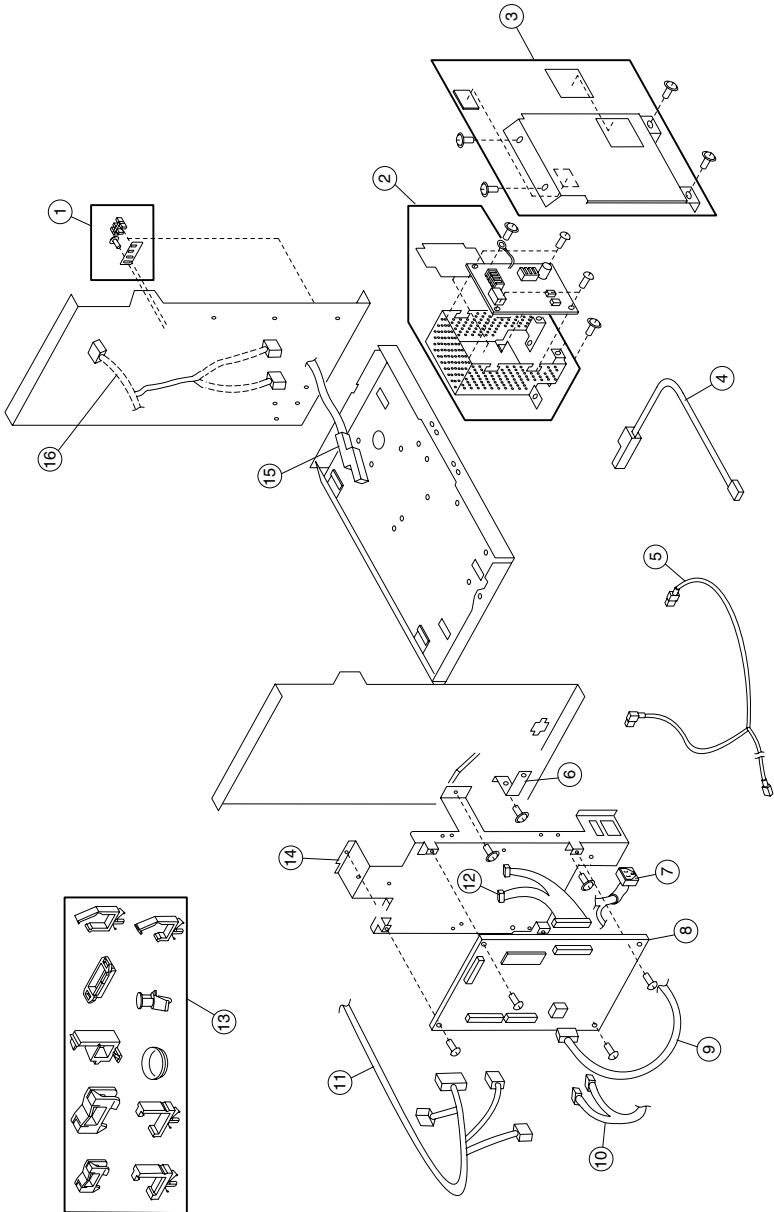

Assembly 29: Finisher electronics

Index	P/N	Units	Description
29-1	56P9306	1	Assembly, upper limit sensor
2	56P9303	1	Supply, power
3	56P9351	1	Assembly, power supply plate
4	56P9435	1	Cable, set switch
5	56P9358	1	Cord, Y power
5	56P9368	1	Cord, Y power (230 V only)
6	56P9342	1	Assembly, bridge
7	56P9326	1	Cable, DC power supply
8	56P9349	1	Board, finisher control
9	56P9428	1	Cable
10	56P9410	1	Cable
11	56P9325	1	Cable, front side panel
12	56P9343	1	Assembly, sensor cable
13	56P9340	1	Packet, parts
14	56P9420	1	Bracket, finisher control board
15	56P9409	1	Cable
16	56P9324	1	Cable, sensor relay
NS	56P9357	1	Cable, interface

Assembly 30: Finisher docking 1

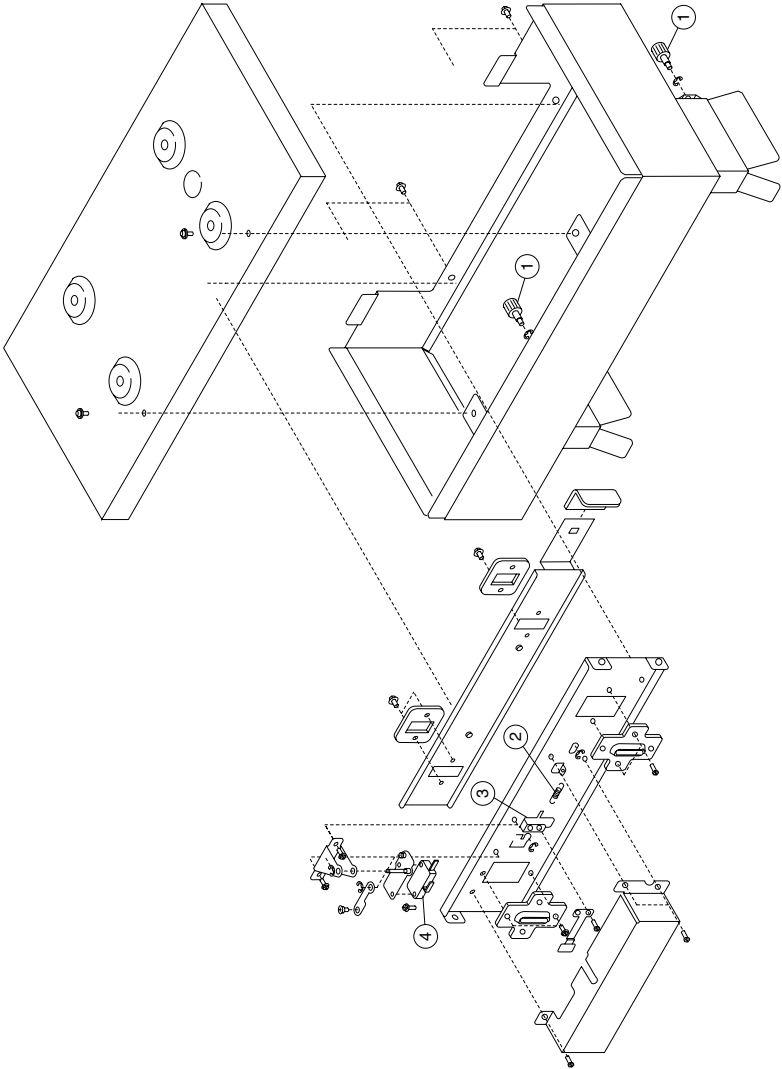

Assembly 30: Finisher docking 1

Index	P/N	Units	Description
30-1	56P9467	2	Screw, thumb
2	56P9468	1	Spring
3	56P9469	1	Bracket
4	56P9470	1	Switch, set

Assembly 31: Finisher docking 2

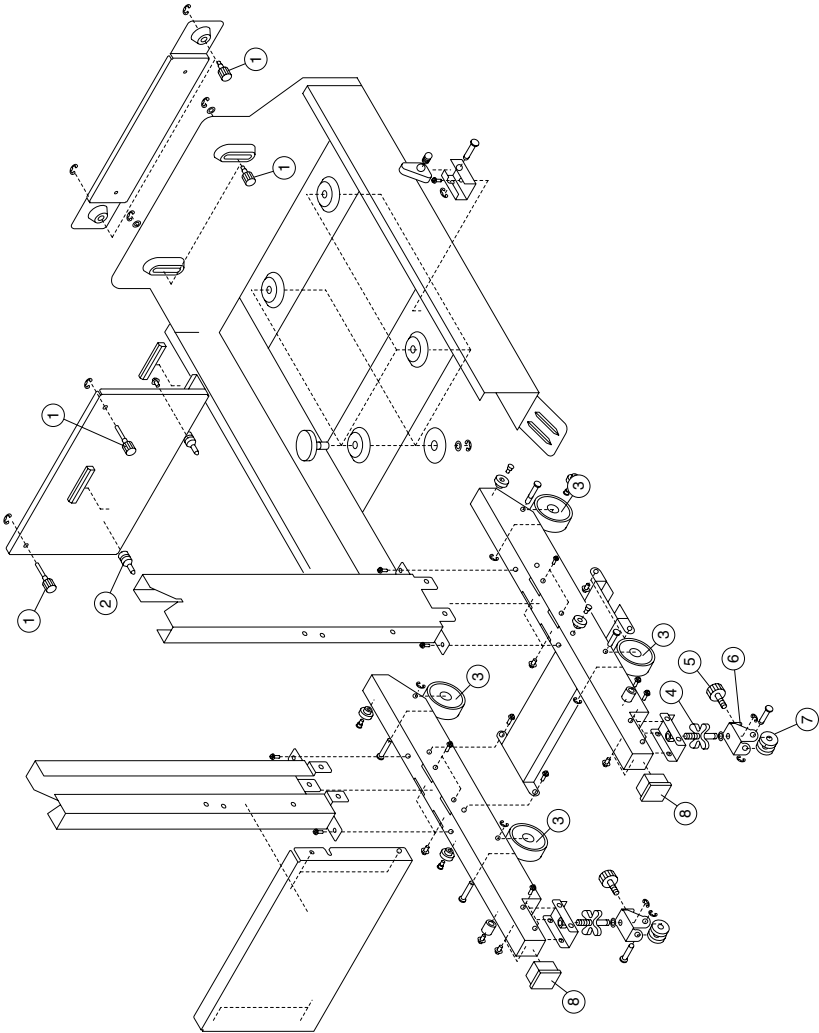

Assembly 31: Finisher docking 2

Index	P/N	Units	Description
31-1	56P9472	2	Screw, lock
2	56P9473	1	Stud, lock
3	56P9474	4	Roller
4	56P9475	2	Knob, caster
5	56P9476	2	Stop, caster
6	56P9477	2	Housing, caster
7	56P9478	4	Caster
8	56P9479	2	Cap

Assembly 32: Miscellaneous/options

Index	P/N	Units	Description
NS	12G6509	1	Card, SDRAM DIMM
NS	56P9910	1	Card assembly, 128MB SDRAM memory
NS	56P9911	1	Card assembly, 256MB SDRAM memory
NS	56P9912	1	Card assembly, 4MB Flash DIMM memory
NS	56P9913	1	Card assembly, 8MB Flash DIMM memory
NS	56P9914	1	Card assembly, 16MB Flash DIMM memory
NS	56P9982	1	Hard Disk, 5+ GB w/Mounting Kit (formatted)
NS	56P9934	1	Card, Token-Ring
NS	12G1695	1	Card, Ethernet 10/100Base-TX
NS	12G1696	1	Card, Ethernet 10BaseT/2
NS	56P0161	1	Card, RS-232C serial/parallel 1284 A-C interface
NS	99A0560	1	Card, Tri-Port adapter
NS	99A0424	1	Card, infrared adapter
NS	99A0545	1	Card, external serial adapter
NS	56P0159	1	Card, Coax/Twinax adapter for SCS
NS	56P0162	1	Adapter, parallel 1284 C-B
NS	13A0296	1	Cable, Twinax
NS	13A0297	1	Cable, Coax
NS	56P0598	1	Card, CGM
NS	56P1204	1	IPDS/SCS/TNe (C910)
NS	56P1762	1	IPDS/SCS/TNe (C912)
NS	56P9923	1	Card, ImageQuick™ (C910)
NS	56P9442	1	Card, ImageQuick (C912)
NS	56P1121	1	Card, bar code (C910)
NS	56P9440	1	Card, bar code (C912)
NS	56P9441	1	Card, PrintCryption™ (C912)
NS	56P9925	1	Card, PRESCRIBE
NS	56P9926	1	Software, Optra Forms™
NS	56P9927	1	Software, Optra Forms Director
NS	56P9928	1	DIMM, Lexmark Forms 4MB Flash
NS	56P9929	1	DIMM, Lexmark Forms 8MB Flash
NS	56P9930	1	DIMM, Lexmark Forms 16MB Flash

Assembly 32: Miscellaneous/options

Index	P/N	Units	Description
NS	56P9932	1	Hard Disk, Lexmark Forms
NS	56P9942	1	Mounting Kit, hard drive
NS	56P9936	1	Simplified Chinese font kit
NS	56P9935	1	Traditional Chinese font kit
NS	56P9975	1	Japanese font kit
NS	7370516	1	Kit, printer relocation
NS	7370567	1	Kit, duplex relocation
NS	7370569	1	Kit, 500-sheet tray relocation

Assembly 32: Parts packets

Index	P/N	Units	Description
NS	56P9945	1	Parts packet, containing: <ul style="list-style-type: none"> • 50 Bind S-tight screws, 3x6, Zn-3R • 50 Bind S-tight screws, 3x15, Zn-3K • 50 Bind P-tight screws, 3x8, Zn-3K • 50 Bind P-tight screws, 3x10, Zn-3K • 50 Bind P-tight screws, 3x6, Zn-3K • 50 Bind P-tight screws, 3x8, Ni-3 • 50 Bind screws, M3x6, Ni-3
NS	56P9946	1	Parts packet, containing: <ul style="list-style-type: none"> • 50 Bind S-tight screws, 3x6, Zn-3R • 50 Bind P-tight screws, 2x10, Zn-3K • 50 Bind P-tight screws, 3x4, Zn-3K • 50 Bind P-tight screws, 3x6, Zn-3K • 50 Bind P-tight screws, 3x8, Zn-3K • 50 Bind P-tight screws, 3x8, Ni-3 • 50 Bind screws, M3x4, Zn-3K • 50 E-rings, ES-5, ACP • 50 Spring pins, 3x12, ACP • 50 Parallel pins, 2.5x18
NS	56P9947	1	Parts packet, including: <ul style="list-style-type: none"> • 50 Bind S-tight screws, 3x6, Zn-3R • 50 Bind P-tight screws, 3x8, Zn-3K • 50 Bind P-tight screws, 3x10, Zn-3K • 50 Bind screws, M3x4, Zn-3K • 50 Bind screws, M3x8, Zn-3K • 50 Bind screws, M3x6, Ni-3 • 50 Screws with washers, M3x30, Zn-3K • 50 E-rings, ES-6, ACP

Assembly 32: Parts packets (continued)

Index	P/N	Units	Description
NS	56P9948	1	Parts packet, including: <ul style="list-style-type: none"> • 50 Bind S-tight screws, 3x6, Zn-3R • 50 Bind P-tight screws, 3x6, Zn-3K • 50 Bind P-tight screws, 3x8 Zn-3K • 50 Bind screws, M3x4, Zn-3K • 50 Bind screws, M3x6, Zn-3K • 50 Bind screws, M3x8, Zn-3K • 50 Pans with flange P-tight screws, 3x8, Zn-3K • 50 E-rings, ES-5, ACP • 50 E-rings, ES-6, ACP • 50 Spring pins, 2x10, ACP
NS	56P9949	1	Parts packet, including <ul style="list-style-type: none"> • 50 Bind S-tight screws, 3x6, Zn-3R • 50 Bind S-tight screws, 3x8, Zn-3R • 50 E-rings, ES-4, ACP
NS	56P9950	1	Parts packet, including: <ul style="list-style-type: none"> • 50 Bind S-tight screws, 3x6, Zn-3R • 50 Bind P-tight screws, 3x6, Zn-3K • 50 Bind P-tight screws, 3x8, Zn-3K • 50 E-rings, ES-3 ACP • 50 E-rings, ES-5, ACP • 50 E-rings, ES-6, ACP • 50 Spring pins, 2x10, ACP • 50 Bind screws, M3x8, Zn-3K • 50 Bind screws, M2x8, Ni-3

Assembly 32: Parts packets (continued)

Index	P/N	Units	Description
NS	56P9951	1	Parts packet, including: <ul style="list-style-type: none"> • 50 Bind S-tight screws, 3x6, Zn-3R • 50 Bind S-tight screws, 3x8, Zn-3R • 50 Bind S-tight screws, 3x12, Zn-3R • 50 Bind P-tight screws, 3x8, Zn-3K • 50 Bind screws, M3x4, Zn-3K • 50 Bind screws, M3x6, Zn-3K • 50 Bind screws, M3x12, Zn-3K • 50 Pans with flange P-tight screws, 3x10, Zn-3K • 50 Screws with washers, M3x30, Zn-3K • 50 Screws with washers, M4x8, Zn-3K • 50 Screws with washers, M4x12, Zn-3K • 50 Screws with washers, M3x6, Ni-3(BS) • 50 Screws with washers, M4x8, Ni-3(BS) • 50 Screws with spring-washers, M3x8, Ni-3(BS) • 50 Screws with spring-washers, M4x8, Ni-3(BS) • 50 Natt with flange sereit, M3, Ni-3 • 50 E-rings, ES-2.5, ACP • 50 Spring pins, 3x10, ACP
NS	56P9952	1	Parts packet, including: <ul style="list-style-type: none"> • 50 Bind S-tight screws, 3x6, Zn-3R • 50 Bind screws, M3x6, Zn-3K • 50 Bind screws, M3x10, Zn-3K • 50 Bind screws, M3x6, Ni-3

Assembly 32: Parts packets (continued)

Index	P/N	Units	Description
NS	56P9953	1	Parts packet, including: <ul style="list-style-type: none"> • 50 Bind S-tight screws, 3x6, Zn-3R • 50 Bind P-tight screws, 3x6, Ni-3 • 50 Bind screws, M3x4, Zn-3K • 50 Bind screws, M3x4, Zn-3K • 50 Bind screws, M3x5, Zn-3K • 50 Screws with washers, M3x10, Zn-3R • 50 Screws with washers, M3x8, Zn-3K • 50 Screws with washers, M3x6, Ni-3(BS) • 50 E-rings, ES-4, ACP • 50 E-rings, ES-5, ACP • 50 C-rings, C-21, ACP
NS	56P9954	1	Parts packet, including: <ul style="list-style-type: none"> • 50 Bind P-tight screws, 3x6, Zn-3K • 50 Bind P-tight screws, 3x8, Zn-3K • 50 Bind screws, M4x8, Zn-3K • 50 Pans with flange P-tight screws, 3x10, Zn-3K • 50 E-rings, ES-5, ACP
NS	56P9955	1	Parts packet, including: <ul style="list-style-type: none"> • 50 Bind S-tight screws, 3x6, Zn-3R • 50 Bind screws, M3x6, Zn-3K • 50 Bind screws, M3x8, Ni-3 • 50 E-rings, ES-5, ACP

Assembly 32: Parts packets (continued)

Index	P/N	Units	Description
NS	56P9956	1	Parts packet, including: <ul style="list-style-type: none"> • 50 Bind S-tight screws, 3x6, Zn-3R • 50 Bind S-tight screws, 3x8, Zn-3R • 50 Bind P-tight screws, 3x6, Zn-3K • 50 Bind P-tight screws, 3x8, Zn-3K • 50 Bind screws, M3x4, Zn-3K • 50 Bind screws, M3x6, Zn-3K • 50 E-rings, ES-5, ACP • 50 E-rings, ES-6, ACP • 50 Spring pins, 2x10, ACP • 50 Spring pins, 3x10, ACP
NS	56P9957	1	Parts packet, including: <ul style="list-style-type: none"> • 50 E-rings, ES-3, ACP • 50 E-rings, ES-4, ACP • 50 E-rings, ES-6, ACP • 50 R-screws, M3x6 • 50 R-screws, M3x8 • 50 R-screws, M4x6 • 50 Pans S-tight screws, M3x6 • 50 RP-tight screws, M3x8,
NS	56P9958	1	Parts packet, including: <ul style="list-style-type: none"> • 50 Bind S-tight screws, 3x6, Zn-3R • 50 Bind P-tight screws, 4x8, Zn-3R • 50 Pan screws, M4x6 Zn-3R • 50 Pan screws, M4x12, Zn-3R • 50 E-rings, ES-6, ACP • 50 RP-tight screws, M4x12 • 50 RS-tight screws, M4x6 • 50 RS-tight screws, M4x8 • 50 RS-tight screws, M4x12

Assembly 32: Parts packets (continued)

















Index	P/N	Units	Description
NS	56P9958	1	Parts packet, including: <ul style="list-style-type: none"> • 50 E-rings, ES-3, ACP • 50 E-rings, ES-4, ACP • 50 E-rings, ES-6, ACP • 50 RS-set screw cp, M3x3, Zn-3K • 50 RS-tight screws, M4x6, • 50 RS-tight screws, M4x8,
NS	56P9959	1	Parts packet, including: <ul style="list-style-type: none"> • 50 E-rings, ES-3, ACP • 50 E-rings, ES-4, ACP • 50 E-rings, ES-6, ACP • 50 RS-set screw cp, M3x3, Zn-3K • 50 RS-tight screws, M4x6 • 50 RS-tight screws, M4x8
NS	56P9960	1	Parts packet, including: <ul style="list-style-type: none"> • 50 Bind S-tight screws, 3x10, Zn-3R • 50 E-rings, ES-4, ACP • 50 RS-tight screws, M3x24 • 50 RS-tight screws, M4x6 • 50 RS-tight screws, M4x8 • 50 RS-tight round top screws, M3x6
NS	56P9961	1	Parts packet, including: <ul style="list-style-type: none"> • 50 E-rings, ES-4, ACP • 50 RS-tight screws, M3x8 • 50 RS-tight screws, M3x24 • 50 RS-tight screws, M4x6 • 50 RS-tight screws, M4x8

Assembly 32: Parts packets (continued)



Index	P/N	Units	Description
NS	56P9962	1	Parts packet, including: <ul style="list-style-type: none"> • 50 Screws with spring-washers, M4x30, Zn-3R • 50 E-rings, ES-5, ACP • 50 Plain washers, M4, Zn-3R • 50 RS-tight screws, M4x6
NS	56P9963	1	Parts packet, including: <ul style="list-style-type: none"> • 50 Bind S-tight screws, 3x8, Zn-3R • 50 Bind S-tight screws, 4x6, Zn-3R • 50 Pan screws, M4x20, Zn-3R • 50 E-rings, ES-6, ACP • 50 RS-tight screws, M4x6 • 50 RS-tight round top screws, M4x6

Assembly 33: Finisher parts packet

P/N 56P9480

Pin		Retaining Ring -E Type	
Screw		Spring Pin	
Screw		Screw	
Tapping Screw		Spring Lock Washer	
Tapping Screw		Toothed Lock Washer	
Tapping Screw		Resin Ring	
Tapping Screw		Nut	
Set Screw		Tapping Screw	

5055-xxx

Plain Washer		Tapping Screw	
		Screw	

Index

A

- abbreviations 1-33
- adjustments
 - finisher hole punch alignment 3-94
 - high-capacity paper feed timing belt 4-3
 - procedures after replacement 2-1
- attendance messages 2-34

C

- clearing the error log 3-32
- communication error
 - finisher 2-17
 - printer/printhead controller board 2-16
- configuration ID 1-32, 3-30
- connectivity 1-23
- connectors
 - duplex unit controller board 5-16
 - extension paper feeder controller board 5-16
 - high voltage power supply board 5-15
 - motor drive board 5-16
 - power source unit 1 board 5-14
 - power source unit 2 board 5-14
 - printer controller board 5-8
 - printhead controller board 5-12
 - RIP board 5-13
 - sensor board 5-15
 - size sensor board 5-17
- counters
 - permanent page counter 3-29
 - setting page count 3-29
- covers
 - front left removal 4-5
 - front removal 4-5
 - left side removal 4-7
 - locations 5-1
 - operator panel removal 4-34

- parts catalog 7-2, 7-4, 7-6, 7-8, 7-10
- rear removal 4-6
- right side removal 4-8
- RIP board removal 4-9
- solenoid removal 4-6
- top cover removal 4-4

D

- defaults 3-26
- development unit 3-34
- device tests 3-23
- diagnostic aids 3-1
- diagnostic information 2-1
- diagnostic mode
 - accessing the menu 3-6
 - exiting 3-32
- diagnostics
 - image quality troubleshooting 2-88
 - maintenance analysis procedures (MAPS) 2-54
 - printer setup 3-26
 - service checks 2-68
 - service error messages 2-4
 - symptom tables 2-63
- DIP switch settings 3-60
- driving parts layout 5-20
- drum counters 3-28
- duplex unit
 - parts catalog 7-38, 7-40
 - removals 4-76
 - connector 4-75
 - feed roller and solenoid 4-78
 - paper carrying motor 4-80
 - side fence 4-79
 - side fence motor assembly 4-79
 - timing belt 4-76
 - theory of operation 3-44

E

- electrical
 - diagram 5-19
 - finisher diagram 5-26
 - finisher, parts catalog 7-66
 - high-capacity feeder diagram 5-19
 - parts catalog 7-22
- eraser removal 4-27
- error log
 - clearing 3-32
 - viewing 3-31
- error messages 2-4
- exiting diagnostics mode 3-32
- expansion feeder
 - parts catalog 7-32, 7-34
 - removal 4-67
 - theory of operation 3-43

F

- fans
 - main unit fan removal 4-32
 - upper fan removal 4-66
- finisher
 - adjusting wheels 3-88
 - aligning finisher and printer 3-80
 - aligning sides of finisher 3-84
 - aligning top of finisher 3-86
 - attaching cables 3-90
 - bins, attaching 3-79
 - docking plate and guide rail, attaching 3-73
 - electrical 5-26
 - electrical parts functions 3-64
 - elevator sequence 3-71
 - hole punch theory 3-69
 - installation 3-73
 - inverted paper path 3-67
 - jogging 3-70
 - lowering and raising 3-82
 - offsetting 3-70

- parts catalog
 - covers 7-54
 - docking 7-68, 7-70
 - electronics 7-66
 - elevator 7-64
 - feed 1 7-58
 - feed 2 7-62
 - frame 7-56
- removals
 - control board 4-90
 - elevator motor 4-91
 - external covers 4-89
 - feed motor assembly 4-91
 - hole punch 4-92
 - inverter paper exit discharge brush 4-93
 - inverter paper exit roller 4-93
 - jogging unit 4-95
 - path select gate 4-96
 - power supply 4-99
 - registration roller 4-100
 - registration roller clutch 4-101
 - stack area discharge brush 4-102
 - staple unit 4-102
 - straight paper exit discharge brush 4-103
 - straight paper exit roller 4-103
 - timing belts 1 and 2 4-105
 - tractor belt 4-106
 - tractor drive motor assembly 4-108
 - stand 3-75
 - stapling mechanism 3-71
 - straight paper path 3-65
 - tests 3-20
 - theory of operation 3-61
- fuser unit
 - parts catalog 7-28
 - removal 4-21
 - theory of operation 3-40

G

- general information 1-1

H

- hardware tests 3-12
- high-capacity feeder
 - call roller removal 4-82
 - covers removal 4-81
 - diagram 5-18
 - high-capacity paper feed timing belt adjustment 4-3
 - paper end sensor removal 4-84
 - paper feed configuration 5-18
 - paper feed roller removal 4-82
 - paper level sensor removal 4-87
 - paper size sensors (1, 2) removal 4-84
 - parts catalog 7-42, 7-44, 7-46, 7-48, 7-50, 7-52
 - pickup solenoid removal 4-83
 - power supply removal 4-88
 - reverse roller removal 4-82
 - tests 3-18
 - sensor/switch test 3-19
 - theory 3-52
 - tray motor removal 4-86
- hole punch
 - adjustment 3-94
 - removal 4-92
 - test 3-20
 - theory of operation 3-69

I

- image quality troubleshooting 2-88
- initial check 2-3
- installation
 - environment 2-3

L

- LEDs
 - cleaning 2-90
- locations 5-1
 - components 5-6
 - covers 5-1
 - high capacity feeder 5-18
 - major parts 5-2
 - sensor and switches 5-4
- lubricants 6-2

M

- maintenance
 - approach 1-29
 - cleaning 1-29, 6-2
 - dip switch specifications 3-60
 - inspection 1-29
 - lubricants 6-2
 - periodic 6-2
 - recommendations 1-30
- maintenance analysis procedures (MAPS)
 - false close top door 2-54
 - false close tray (x) top cover 2-55
 - false print unit missing 2-57
 - false side door open 2-54
 - false tray (x) low/empty 2-56
 - false 30 oil coating roll missing 2-57
 - false 40 tray (x) size sensor error 2-59
 - false 41 open bin 1 exit tray 2-59
 - false 88 toner low/toner empty 2-58
 - paper size 2-62
 - unrecoverable check tray (x) or duplex connection 2-60
- maintenance kit 6-1
- maintenance menu 3-32
- menu overview 3-4
- menu settings 3-4
- messages
 - printer messages 2-4
 - service errors 2-4
- models 1-1
- multipurpose feeder
 - theory of operation 3-38
 - tray removal 4-34

O

- operator menu
 - disabled 3-4
- operator panel
 - buttons 3-3
 - using 3-2
- options 1-22
 - parts catalog 7-72

P

- page count 3-29
- paper and media
 - guidelines 1-20
 - paper checks 2-3
 - print area 1-21
 - printer capacity 1-18
 - sizes 1-10
 - specifications 1-8
 - types 1-15
 - weights 1-15
- paper exit tray removal 4-10
- paper feeding
 - cassette feeder 3-37
 - multipurpose feeder 3-37
 - paper jams 3-46
 - theory 3-37
 - weight of paper 3-45
- paper jams 3-46
- part number 1-32
- parts catalog
 - base 7-16, 7-18, 7-20
 - cassette 7-30
 - covers 7-2, 7-4, 7-6, 7-8, 7-10
 - duplex unit 7-38, 7-40
 - electrical 7-22
 - expansion feeder 7-32, 7-34
 - finisher
 - covers 7-54
 - docking 7-68, 7-70
 - electronics 7-66
 - elevator 7-64
 - feed 7-58, 7-62
 - frame 7-56
 - finisher parts packet 7-81
 - fuser unit 7-28
 - high-capacity feeder 7-42, 7-44, 7-46, 7-48, 7-50, 7-52
 - miscellaneous 7-72
 - options 7-72
 - parts packets 7-74
 - RIP board 7-26
 - upper unit 7-12
- parts packets 7-74, 7-81
- parts return 1-30
- periodic maintenance 6-2

- permanent page count 3-29
- POST 3-1
- power and electrical specifications 1-26
- power-on self-test sequence 3-1
- preventive maintenance 6-1
- print quality pages 3-11
- print quality problems 2-88
- printed circuit boards
 - inspection 4-2
 - precautions 4-1
 - replacement 4-2
 - transportation and storage 4-1
- printer controller board communication error 2-16
- printer environment 1-27
- printer messages 2-4
- printer setup 3-26
 - configuration ID 3-30
 - drum counters 3-28
- printhead
 - LED printhead removal 4-24
 - parts catalog 7-15
- printhead controller board 7-13
- printhead controller board removal 4-44
- printing menu settings 3-4

R

- relocation kit 7-73
- removals
 - belt up/down clutch 4-10
 - belt up/down detection sensor 4-11
 - cassette guide 4-12
 - connector, duplex unit 4-13
 - covers
 - front 4-5
 - front left 4-5
 - left side 4-7
 - operator panel 4-34
 - rear 4-6
 - right side 4-8
 - RIP board 4-9
 - solenoid 4-6
 - top 4-4
 - density sensor 4-14

- drive gear unit sensor assembly 4-15
- drive motor assembly 4-16
- duplex unit 4-76
 - connector 4-75
 - feed roller and solenoid 4-78
 - paper carrying motor 4-80
 - pressure roller and solenoid 4-77
 - side fence motor assembly 4-79
 - side fence removal 4-79
 - timing belt 4-76
- duplex unit connector 4-13
- electronic box 4-17
- eraser 4-27
- expansion paper feeder 4-67
- face down guide assembly 4-18
- face up paper exit assembly 4-19
- fanning pad 4-19
- finisher
 - control board 4-90
 - elevator motor 4-91
 - external covers 4-89
 - feed motor assembly 4-91
 - hole punch 4-92
 - inverter paper exit discharge brush 4-93
 - inverter paper exit roller 4-93
 - jogging unit 4-95
 - path select gate removal 4-96
 - power supply 4-99
 - registration roller 4-100
 - registration roller clutch 4-101
 - stack area discharge brush 4-102
 - staple unit 4-102
 - straight paper exit discharge brush 4-103
 - straight paper exit roller 4-103
 - timing belts 1 and 2 4-105
 - tractor belt removal 4-106
 - tractor drive motor assembly 4-108
- front cover open switch actuator 4-20
- full sensor 4-18
- fuser 4-21
- gear cover 4-22
- high voltage power supply board 4-23
- high-capacity feeder
 - call roller 4-82
 - covers 4-81
 - paper end sensor 4-84
 - paper feed roller 4-82
 - paper level sensor 4-87
 - paper size sensors (1, 2) 4-84
 - pickup solenoid 4-83
 - power supply 4-88
 - reverse roller 4-82
 - tray motor 4-86
- LED printhead 4-24
- lock handle assembly 4-28
- main drive unit 4-29
- main unit fan 4-32
- motor drive board 4-33
- multipurpose feeder frame assembly 4-22
- multipurpose feeder paper present sensor 4-33
- multipurpose feeder tray 4-34
- paper carrying frame 4-35
- paper carrying roller 4-36
- paper exit motor 4-18
- paper exit tray 4-10
- paper feed frame 4-37
- paper feed roller 4-38
- paper feed solenoid 4-54
- paper present sensor 4-38
- paper remaining sensor 4-39
- paper size sensor board assembly 4-39
- power supply 1 4-40
- power supply 2 4-41
- power switch 4-42
- printer controller 4-43
- printhead controller board 4-44
- registration clutch 4-47
- registration frame 4-47
- registration sensor 4-48
- right slide rail 4-49
- RIP box 4-49
- sensor board 4-50
- sensor cleaner 4-14

5055-xxx

- separation fingers 4-14
- stay arm 4-51
- sub-frame 4-52
- temperature/humidity sensor 4-54
- top unit 4-55
- transfer belt
 - inoperable operator panel 4-60
 - normal removal 4-56
 - partially removed 4-64
 - unrecoverable error code 4-60
- turn guide cover sensor 4-65
- upper fan 4-66
- repair information
 - handling printed circuit boards 4-1
 - service precautions 4-1

S

- safety information 1-xi
- sensors
 - belt up/down detection 4-11
 - density 4-14
 - drive gear unit 4-15
 - finisher, functions 3-64
 - high-capacity feeder paper end sensor removal 4-84
 - high-capacity feeder paper level 4-87
 - high-capacity feeder paper size sensors (1, 2) removal 4-84
 - humidity 4-54
 - locations 5-4
 - multipurpose feeder paper present 4-33
 - paper full 4-18
 - paper remaining 4-39
 - paper size sensor board assembly 4-39
 - sensor board 4-50
 - temperature 4-54
 - turn guide cover 4-65
- serial number 1-32, 3-29

- service checks 2-68
 - drive 1 DC motor 2-68
 - drive 2 stepper motor 2-68
 - duplex 2-69
 - expansion paper feed 2-69
 - face down stacker full 2-70
 - face up exit assembly 2-82
 - high capacity feeder (HCF) 2-70
 - marks on paper 2-72
 - operator panel 2-73
 - options 2-98
 - paper carrying 2-74
 - paper exit, face up exit assembly 2-82
 - paper tray missing 2-83
 - photodeveloper missing 2-84
 - power supply 2-85
 - serial port 2-98
 - transfer belt up/down 2-87
- service communication 2-16
- service error
 - tray elevator motor 2-32
 - 900 - unrecoverable software error 2-4
 - 910 - drive motor error 2-4
 - 911 - paper exit motor error 2-5
 - 912 - high capacity feed motor error 2-5
 - 917 - RIP fan error 2-5
 - 918 - main unit fan error 2-6
 - 919 - power supply fan error 2-6
 - 92x - toner sensor error 2-9
 - 920 - fuser error - fuser heater trouble 2-6
 - 923 - upper fuser thermistor open error 2-7
 - 924 - lower fuser thermistor open error 2-7
 - 925 - HVU error 2-8
 - 930 - printhead error, yellow 2-10
 - 931 - printhead error, magenta 2-11
 - 932 - printhead error, yellow 2-12
 - 933 - printhead error, black 2-13
 - 934 - drum sensor, color 2-14
 - 935 - drum sensor, black 2-14
 - 936-9 - cassette error 2-15

- 940 - high-capacity feed sensor error 2-15
 - 941 - high-capacity feed tray error 2-15
 - 942 - duplex error 2-16
 - 945 - engine flash error 2-16
 - 946 - printer/printhead controller board communication 2-16
 - 947 - finisher communication error 2-17
 - 948 - machine ID error 2-17
 - 949 - tray (x) communication error 2-18
 - 950 - printer control board 2-18
 - 952 - NVRAM chip failure 2-18
 - 954 - NVRAM CRC failure 2-18
 - 955 - code CRC 2-19
 - 956 - processor failure 2-19
 - 957 - ASIC failure 2-19
 - 958 - NAND failure 2-19
 - 960 - RAM slot 1 bad 2-19
 - 961 - RAM slot 2 bad 2-19
 - 962 - RAM slot 3 bad 2-19
 - 964 - emulation error 2-19
 - 970 - standard network error 2-20
 - 975 - unrecognizable network port 2-20
 - 976 - unrecoverable software error in network port 2-20
 - 978 - bad checksum 2-20
 - 979 - Flash parts failed 2-20
 - 980 - face up/down switching error 2-21
 - 981 - belt up/down sensor 2-22
 - 982 - sensor controller 2-23
 - 983 - black gear sensor 2-24
 - 984 - yellow gear sensor 2-24
 - 985 transfer belt thermistor 2-25
 - 986 - transparency (OHP) sensor 2-25
 - 993 - CPU 2-26
 - 994 - density sensor 2-27
 - 995 - finisher main feed motor 2-28
 - 996 - finisher jogging motor 2-30
 - 997 - finisher tractor motor 2-31
 - 999 - stapler motor 2-33
 - service errors 2-4
 - service precautions 4-1
 - setting configuration ID 3-30
 - setting the page count 3-29
 - size detection 3-57
 - specifications
 - connectivity 1-23
 - environment 1-27
 - paper and media 1-8
 - power and electrical 1-26
 - technical 1-2
 - start 2-3
 - sub-frame
 - parts catalog 7-17
 - removal 4-52
 - switches, locations 5-4
 - symptom table 2-63
- ## T
- technical specifications 1-2
 - tests
 - button 3-12
 - device 3-23
 - disk test/clean 3-24
 - DRAM memory 3-12
 - finisher hole punch 3-20
 - finisher sensor test 3-20
 - finisher staple 3-20
 - flash 3-25
 - hardware 3-12
 - high capacity paper feed 3-18
 - high capacity paper feed sensor/switch 3-19
 - input source print 3-10
 - LCD hardware 3-12
 - parallel wrap 3-14
 - print 3-10
 - print quality pages 3-11
 - quick disk 3-23
 - ROM memory 3-13
 - serial wrap 3-16

5055-xxx

theory

- belt unit 3-42
- belt up/down 3-43
- cassette paper feeder 3-37
- cleaning unit 3-35
- clearing paper jams 3-46
- configuration 3-33
- delivery 3-41
- development unit 3-34
- drive system 3-36
- duplex unit 3-44
- electrophotography 3-33
- electrophotography process 3-33
- expansion paper feeder 3-43
- fuser unit 3-40
- high capacity feeder (HCF) 3-52
- maintenance mode 3-60
- multipurpose feeding 3-38
- paper feeding 3-37
- paper feeding / fusing 3-35
- processes 3-33
- processes and configuration 3-33
- registration unit 3-38
- separation unit 3-39
- transfer unit 3-34

tools 1-31

transfer belt

- removal 4-56
- removal, inoperable operator panel
4-60
- removal, partial removed 4-64

tray up/down mechanism 3-54

troubleshooting 2-88

V

viewing the error Log 3-31

viewing the permanent page count 3-29

W

weight, printer 1-3

Part number index

P/N	Description	Page
11D0328	Power cord - USA, Canada, APG, LAD	7-25
11D0329	Power cord - Peru	7-25
11D0330	Power cord - Argentina	7-25
11D0331	Power cord - Brazil	7-25
11D0332	Power cord - Chile	7-25
11D0333	Power cord - Denmark	7-25
11D0334	Power cord - Belgium, Europe, England, France, Germany, Spain	7-25
11D0335	Power cord - Italy	7-25
11D0336	Power cord - Swiss/French, German, Italian	7-25
11D0337	Power cord - UK, Israel, South Africa	7-25
11G0199	Guide, wire	7-33
11G0219	Interrupter, photo	7-35
11G0243	Interrupter, photo	7-17, 7-23
11G0283	Pad, fanning	7-21
11G0291	Clutch, paper feed	7-35
11G0297	Gear, paper carrying	7-35
11G0399	Plate, ground	7-33
11G0422	Gear, feeder B	7-33
11G0423	Gear, feeder A	7-33
11G0563	Interrupter, photo	7-35
12G1695	Card, Ethernet 10/100Base-TX	7-72
12G1696	Card, Ethernet 10BaseT/2	7-72
12G6509	Card, SDRAM DIMM	7-72
12G7360	Board, operator panel	7-3
13A0296	Cable, Twinax	7-72
13A0297	Cable, Coax	7-72
56P0159	Card, Coax/Twinax adapter for SCS	7-72
56P0161	Card, RS-232C serial/parallel 1284 A-C interface	7-72
56P0162	Adapter, parallel 1284 C-B	7-72
56P0598	Card, CGM	7-72

5055-xxx

56P1121 Card, bar code (C910)	7-72
56P1204 IPDS/SCS/TNe (C910)	7-72
56P1762 IPDS/SCS/TNe (C912)	7-72
56P9300 Assembly, jogging unit	7-63
56P9301 Assembly, guide stack	7-63
56P9302 Assembly, center guide	7-57
56P9303 Supply, power	7-67
56P9304 Assembly, hook front	7-65
56P9305 Assembly, tension D	7-59
56P9306 Assembly, upper limit sensor	7-67
56P9307 Assembly, hook rear	7-65
56P9308 Assembly, elevator motor	7-65
56P9309 Assembly, exit guide inverter	7-57
56P9310 Gate	7-59
56P9311 Bushing	7-59, 7-65
56P9312 Roller, F	7-59
56P9313 Unit, 3 hole punch (U.S. only)	7-57
56P9314 Unit, 4 hole punch (non U.S.)	7-57
56P9315 Assembly, punch drive	7-59
56P9316 Bushing	7-61
56P9317 Belt	7-61
56P9318 Spring, B	7-59
56P9319 Assembly, exit guide straight	7-57
56P9321 Spring, I	7-57
56P9324 Cable, sensor relay	7-57, 7-67
56P9325 Cable, front side panel	7-67
56P9326 Cable, DC power supply	7-67
56P9327 Cable, upper side panel	7-57
56P9329 Assembly, tractor motor	7-63
56P9331 Wire	7-65
56P9332 Spring, C	7-65
56P9333 Belt, timing (60S3M408)	7-63
56P9334 Assembly, solenoid	7-59
56P9335 Clutch, registration	7-59
56P9338 Pulley, T56	7-59
56P9339 Belt, timing 60S2M334	7-59
56P9340 Packet, parts	7-67
56P9341 Assembly, feed motor	7-59
56P9342 Assembly, bridge	7-67
56P9343 Assembly, sensor cable	7-67
56P9344 Cover, staple inner A	7-57
56P9345 Cover, staple inner B	7-57

56P9347 Panel, left upper	7-55
56P9348 Screw, A	7-55
56P9349 Board, finisher control	7-67
56P9350 Assembly, staple cover	7-55
56P9351 Assembly, power supply plate	7-67
56P9352 Assembly, lower left panel	7-55
56P9352 Panel, lower left	7-65
56P9353 Cover, top	7-55
56P9354 Assembly, dust box	7-55
56P9355 Cover, front	7-55
56P9356 Cover, rear	7-55
56P9357 Cable, interface	7-67
56P9358 Cord, Y power	7-67
56P9359 Tray, upper	7-55
56P9360 Tray, lower	7-55
56P9361 Roller, patting	7-59
56P9363 Stapler	7-55
56P9364 Cover, staple B	7-55
56P9365 Cover, staple A	7-55
56P9366 Lever, B	7-55
56P9367 Cartridge, staple	7-55
56P9368 Cord, Y power (230 V only)	7-67
56P9369 Assembly, spring plate C	7-57
56P9370 Frame, guide	7-57
56P9371 Spring	7-57
56P9372 Brush, static discharge	7-57
56P9373 Screw, M4	7-57
56P9374 Frame, C guide	7-57
56P9375 Shaft, D	7-57
56P9376 Bushing	7-57
56P9377 Roller, D	7-57
56P9378 Plate, E spring	7-57
56P9380 Sensor, photo	7-57
56P9381 Frame, B guide	7-57
56P9382 Sensor	7-65
56P9382 Sensor, photo	7-57
56P9383 Cushion	7-57
56P9384 Plate, B spring	7-57
56P9386 Spring	7-57
56P9387 Handle, jam	7-57
56P9388 Sensor, 1 photo	7-57
56P9389 Bracket	7-57

5055-xxx

56P9390 Plate, cover	7-57
56P9393 Plate, guide holder	7-59
56P9394 Handle	7-57
56P9395 Assembly, guide plate	7-59
56P9396 Spring, H	7-59
56P9397 Gear, Z20	7-59
56P9398 Gear, Z19	7-59
56P9399 Sensor, photo	7-57
56P9400 Roller	7-59
56P9401 Roller, I	7-59
56P9402 Bushing	7-59
56P9403 Spring, A	7-59
56P9404 Spring, F	7-59
56P9405 Roller, G	7-59
56P9406 Pulley, Z24/T42 gear	7-59
56P9407 Belt, timing 60S2M184	7-59
56P9408 Knob	7-59
56P9409 Cable	7-67
56P9410 Cable	7-67
56P9411 Pulley	7-59
56P9412 Spacer	7-59
56P9413 Assembly, motor bracket	7-59
56P9414 Pulley	7-59
56P9415 Pulley, gear Z36/T24	7-61
56P9417 Flange	7-61, 7-63
56P9418 Guide, stack	7-57
56P9420 Bracket, finisher control board	7-67
56P9422 Pin, N	7-63
56P9423 Pulley, Z19/Z20	7-63
56P9428 Cable	7-67
56P9435 Cable, set switch	7-67
56P9436 Cable	7-57
56P9437 Belt, timing	7-63
56P9440 Card, bar code (C912)	7-72
56P9441 Card, PrintCrypton (C912)	7-72
56P9442 Card, ImageQuick (C912)	7-72
56P9448 Washer	7-65
56P9449 Pin	7-65
56P9450 Pulley, wire A	7-65
56P9451 Shutter	7-65
56P9452 Pin, O	7-65

56P9453 Roller, C	7-65
56P9455 Bracket	7-65
56P9456 Gear, Z46/Z33	7-65
56P9457 Gear, Z90/Z14	7-65
56P9458 Gear, Z25/Z20	7-65
56P9459 Drum, wire	7-65
56P9460 Gear, Z30	7-65
56P9463 Pulley, wire B	7-65
56P9465 Assembly, sensor	7-65
56P9467 Screw, thumb	7-69
56P9468 Spring	7-69
56P9469 Bracket	7-69
56P9470 Switch, set	7-69
56P9472 Screw, lock	7-71
56P9473 Stud, lock	7-71
56P9474 Roller	7-71
56P9475 Knob, caster	7-71
56P9476 Stop, caster	7-71
56P9477 Housing, caster	7-71
56P9478 Caster	7-71
56P9479 Cap	7-71
56P9480 Parts packet, finisher	7-81
56P9482 Shaft, A	7-65
56P9500 Cassette, paper feed	7-31
56P9501 Spring, pressure	7-45
56P9501 Spring, pressure pickup	7-49
56P9502 Sensor, turn guide door	7-21
56P9503 Foot, rubber	7-17, 7-33
56P9504 Rail, base right side	7-17
56P9504 Rail, left side	7-33
56P9505 Rail, base left side	7-17
56P9505 Rail, right side	7-33
56P9506 Frame, paper feed	7-35
56P9507 Actuator, paper feed sensor	7-17, 7-35
56P9508 Bracket, ground	7-17, 7-35
56P9509 Bushing, metal	7-35
56P9510 Shaft, paper feed	7-35
56P9511 Roller assembly, paper feed	7-17, 7-35
56P9512 Roller assembly, paper carrying	7-17
56P9513 Bushing, carrying	7-35
56P9514 Roller, noise reduction	7-35
56P9515 Guide, upper cassette	7-17, 7-35

5055-xxx

56P9516 Spring, left cassette guide	7-17, 7-35
56P9517 Spring, right cassette guide	7-17, 7-35
56P9518 Guide, lower left cassette	7-17, 7-35
56P9519 Guide, lower right cassette	7-17, 7-35
56P9520 Handle, waste bottle cam	7-17
56P9521 Lever, size sensor	7-17, 7-33
56P9522 Board, size sensor	7-17, 7-33
56P9523 Cable assembly, size sensor	7-17
56P9524 Screw, slide rail	7-17, 7-33
56P9525 Interrupter assembly, photo	7-41
56P9525 Interrupter, photo	7-39
56P9526 Spring, feed roller	7-41
56P9527 Gear, idler	7-41
56P9528 Interrupter, photo	7-45, 7-51, 7-53
56P9529 Caster, HCF	7-47
56P9530 Switch, push	7-47, 7-49
56P9531 Tray assembly, exit	7-3
56P9532 Cover assembly, front (C910)	7-3
56P9533 Cover assembly, right side	7-3
56P9534 Magnet, right side latch	7-3
56P9535 Cover, solenoid	7-3
56P9536 Cover, left side	7-3
56P9537 Cover, paper feed	7-3
56P9538 Cover, rear	7-3
56P9539 Cover, top	7-3
56P9540 Cover, waste toner bottle	7-3
56P9541 Sensor, resistor	7-49
56P9542 Cover, left front	7-3
56P9543 Magnet, front cover latch	7-3
56P9544 Label, MPT	7-3
56P9545 Label, operator guide	7-3
56P9551 Cover, adjustment	7-3
56P9554 Core, ferrite	7-3
56P9555 Housing, upper operator panel	7-3
56P9556 Housing, lower operator panel	7-3
56P9557 Exit assembly, face up	7-5
56P9566 Guide assembly, face-down	7-7
56P9575 Bushing, face down pinch roller	7-7
56P9576 Pulley, face down feed roller	7-7
56P9578 Belt, face down roller	7-7

56P9584 Guide assembly, turn	7-9
56P9591 Frame, upper	7-13
56P9592 Rail, left side	7-13
56P9593 Holder, rear printhead	7-15
56P9594 Cover, eraser	7-15
56P9595 Lamp, M erase	7-15
56P9596 Lamp, C erase	7-15
56P9597 Lamp, Y erase	7-15
56P9598 Lamp, K erase	7-15
56P9599 Printhead, LED S/N XX-0XXXX	7-15
56P9600 Cable assembly, K13	7-13
56P9601 Cable assembly, K24	7-13
56P9602 Cable assembly, CL13	7-13
56P9603 Cable assembly, CL24	7-13
56P9604 Core, ferrite	7-15
56P9605 Cable assembly, HDFG	7-15
56P9606 Cable assembly, RSPFG	7-15
56P9607 Cable assembly, LFG	7-15
56P9608 Holder, front HSP	7-13
56P9609 Spring, printhead	7-13
56P9610 Rail, right side	7-15
56P9611 Holder, front printhead	7-13
56P9612 Bracket, front upper	7-13
56P9613 Rod, interlocking	7-13
56P9614 Spring, return	7-13
56P9615 Hook, middle	7-13
56P9616 Handle, upper opening	7-13
56P9617 Hook, left	7-13
56P9618 Hook, right	7-13
56P9619 Bracket, rear upper	7-15
56P9620 Board, printhead controller—S/N XX-0XXXX	7-13
56P9621 Bracket, fan holder	7-15
56P9622 Fan, upper right	7-15
56P9623 Fan, upper left	7-15
56P9624 Link, frame	7-13
56P9625 Hook, right link	7-13
56P9626 Cover, hook	7-13
56P9627 Bearing, roller	7-13
56P9628 Pivot, color link	7-13
56P9629 Frame, link	7-15
56P9630 Hook, left link	7-13
56P9637 Frame, printhead controller	7-13

5055-xxx

56P9638 Holder, cable	7-13
56P9639 Connector, upper	7-15
56P9641 Actuator, front cover open switch	7-17
56P9642 Unit, drive	7-17
56P9643 Clutch, drive unit	7-17
56P9644 Cable assembly, drive unit sensor	7-17
56P9645 Sensor, drive unit gear	7-17
56P9646 Frame, sub	7-17
56P9662 Shaft, changing	7-17
56P9663 Clutch, belt up/down	7-17
56P9664 Frame, paper feed	7-17
56P9665 Sensor, paper feed	7-17
56P9666 Support assembly, upper unit	7-19
56P9667 Pin, upper unit support	7-19
56P9668 Handle assembly, lock	7-19
56P9669 Handle, lock	7-19
56P9670 Shroud, cable	7-19
56P9671 Guide, cable	7-19
56P9672 Guide, cable	7-19
56P9673 Cover, electronic	7-19
56P9674 Guide assembly, fuser entrance	7-21
56P9676 Sensor, density	7-21
56P9680 Frame assembly, registration	7-21
56P9681 Clutch, registration	7-21
56P9682 Frame assembly, carrying	7-21
56P9684 Frame assembly, F1 sub	7-21
56P9685 Frame assembly, F2 sub	7-21
56P9686 Rod, lock	7-21
56P9687 Cover, gear	7-21
56P9692 Cable assembly, reg MPF sensor	7-21
56P9693 Stopper, clutch	7-21
56P9694 Unit, transfer belt	7-21
56P9695 Cable, turn guide door sensor	7-21
56P9696 Cable assembly, belt thermistor	7-21
56P9697 Bushing	7-21
56P9698 Motor assembly, 120 V	7-23
56P9699 Motor assembly, 230 V	7-23
56P9700 Solenoid assembly, paper feed	7-23
56P9701 Board, sensor	7-23
56P9702 Cable, belt up/down sensor	7-23
56P9703 Cable assembly, sensor board	7-23

56P9704 Cable assembly, paper remaining sensor	7-23
56P9705 Cable assembly, feeder	7-23
56P9706 Cable, power switch	7-23
56P9707 Switch, power	7-23
56P9708 Cable assembly, duplex connector	7-23
56P9709 Board, 120 V motor driver	7-23
56P9710 Board, 230 V motor driver	7-23
56P9711 Cable, THB drawer	7-23
56P9712 Cable, THB drawer (EMEA)	7-23
56P9713 Fan, power supply	7-23
56P9714 Board, high voltage power supply	7-25
56P9715 Cable high voltage power supply board	7-25
56P9716 Cable assembly, 8 Pin PH controller	7-13
56P9717 Cable assembly, 18 Pin PH controller—S/N XX-0XXXX	7-13
56P9718 Cable assembly, 30 Pin PH controller—S/N XX-0XXXX	7-13
56P9719 Cable assembly, 80 pin RIP printer controller	7-27
56P9720 Cable assembly, PH controller power	7-13
56P9721 Cable assembly, drum eraser	7-25
56P9722 Power supply, 120 V (1)	7-23
56P9723 Power supply, 230 V (1)	7-23
56P9724 Power supply, 120 V (2)	7-25
56P9725 Power supply, 230 V (2)	7-25
56P9726 Cable assembly, printer controller power 1	7-25
56P9727 Cable assembly, printer controller power 2	7-25
56P9729 EPROM, printer controller	7-23
56P9730 Cable assembly, HCF	7-25
56P9731 Cable assembly, finisher	7-25
56P9732 Belt, power supply	7-23
56P9733 Cable assembly, HCPF interface	7-25
56P9734 HCF/finisher D-sub assembly	7-25
56P9736 Cable, operator panel	7-3, 7-27
56P9737 Insulator, sheet	7-23
56P9738 Cable assembly, conditioning joint (230 V only)	7-23
56P9739 Cable asm., conditioning printer controller	7-23
56P9740 Cable, conditioning resistor	7-23
56P9741 Resistor, conditioning (230 V only)	7-23
56P9742 Board, heater drive	7-23
56P9745 Box, RIP	7-27
56P9746 Cover, RIP box	7-27
56P9747 Cable assembly, power MAC	7-27
56P9748 Cable assembly, MIF	7-27
56P9749 Cable assembly, power RIP	7-27

5055-xxx

56P9750 Fan, RIP	7-27
56P9751 Fuser, 120 V	7-29
56P9752 Fuser, 230 V	7-29
56P9765 Cover, front feeder	7-33
56P9766 Cover, left side	7-33
56P9767 Cover, right side A	7-33
56P9768 Cover, rear	7-33
56P9769 Cover, right side B	7-33
56P9770 Cover, right side C	7-33
56P9771 Gear, feeder C	7-33
56P9772 Gear, feeder D	7-33
56P9773 Gear, feeder E	7-33
56P9774 Motor, feeder drive	7-33
56P9775 Cable assembly, size sensor	7-33
56P9776 Board, paper remaining sensor	7-33
56P9777 Cable assembly, upper optional drawer	7-33
56P9778 Cable assembly, lower optional drawer	7-33
56P9779 Board, expansion feeder control	7-33
56P9781 Lever, clutch	7-35
56P9782 Spring, solenoid	7-35
56P9783 Solenoid, feeder	7-35
56P9784 Actuator, paper detection	7-35
56P9785 Cover, paper present sensor	7-35
56P9786 Spring, paper detection sensor	7-35
56P9787 Cable, paper present sensor	7-35
56P9788 Guide, HCF	7-35
56P9789 Guide, turn	7-35
56P9790 Roller, paper carrying	7-35
56P9791 Spring, paper carrying	7-35
56P9792 Holder, roller	7-35
56P9793 Spring, left turn guide	7-35
56P9794 Spring, right turn guide	7-35
56P9795 Cable, paper present sensor	7-35
56P9796 Roller assembly, carrying	7-35
56P9797 Cover, gear	7-35
56P9798 Duplex assembly	7-39
56P9799 Frame, duplex	7-39
56P9800 Screw, duplex mounting	7-39
56P9803 Motor, duplex stepping	7-39
56P9804 Board, duplex interface	7-39
56P9805 Cable assembly, duplex connection	7-39
56P9806 Cable assembly, paper detection	7-39
56P9807 Cable assembly, duplex interface	7-39

56P9808 Interrupter, photo	7-41
56P9809 Roller, drive feed	7-41
56P9810 Roller, follow-up feed	7-41
56P9811 Roller, middle feed	7-41
56P9812 Roller, re-feed	7-41
56P9813 Roll, release	7-41
56P9814 Bearing, release	7-41
56P9815 Spring, reed roller	7-41
56P9816 Spring, re-feed roller	7-41
56P9817 Gear, carrying roller	7-41
56P9818 Pulley, carrying roller timing	7-41
56P9819 Pulley, feed roller	7-41
56P9820 Pulley, re-feed roller	7-41
56P9821 Knob, paper re-feed	7-41
56P9822 Belt, timing	7-41
56P9823 Belt, timing	7-41
56P9824 Plate, paper carrying drawer	7-41
56P9825 Plate, paper re-feed drawer	7-41
56P9826 Guide, front side	7-41
56P9827 Guide, rear side	7-41
56P9828 Motor assembly, paper guide	7-41
56P9829 Solenoid assembly, feed roller	7-41
56P9830 Solenoid assembly, paper re-feed	7-41
56P9831 Cable assembly, duplex drawer	7-41
56P9833 Cover, front	7-43
56P9834 Cover, upper rear	7-43
56P9835 Magnet, latch	7-43
56P9836 Fence, end	7-43
56P9837 Cover, upper	7-43
56P9838 Catch, door	7-43
56P9839 Cover, right	7-43
56P9840 Lever, vertical transport	7-43
56P9841 Cover assembly, upper	7-43
56P9842 Spring, tension	7-43
56P9843 Cover, lower rear	7-43
56P9844 Motor assembly, transport	7-45
56P9845 Sensor assembly, paper feed	7-45
56P9846 Solenoid assembly, paper pickup	7-45
56P9847 Spring, compression	7-45
56P9848 Clutch, paper feed	7-45
56P9849 Roller, manual feed pickup	7-45
56P9850 Roller, manual feed	7-45

5055-xxx

56P9851 Roller, manual feed separate	7-45
56P9852 Limiter, torque	7-45
56P9853 Screw, shoulder	7-47
56P9854 Sensor assembly, photo	7-47
56P9855 Interrupter, photo	7-47
56P9856 Spring, tension	7-47
56P9857 Switch, micro	7-47
56P9858 Connector, I/F	7-47
56P9859 Connector, inlet	7-47
56P9861 Roller, track	7-49
56P9863 Switch, HCF push	7-49
56P9864 Switch, micro	7-49
56P9865 Cable assembly, HCF motor	7-49
56P9866 Cable assembly, paper feed sensor	7-49
56P9867 Cable assembly, drawer ground	7-49
56P9868 Board, high capacity feed	7-49
56P9869 Power supply, HCF	7-49
56P9870 Converter, DC/DC	7-49
56P9871 Cable assembly, I/F	7-49
56P9872 Cable assembly, power supply in	7-49
56P9873 Cable assembly, power supply out	7-49
56P9874 Cable assembly, power supply	7-49
56P9875 Cable assembly, safety switch	7-49
56P9876 Cable assembly, lift motor	7-49
56P9877 Cable assembly, paper size sensor	7-49
56P9878 Cable assembly, sensor	7-49
56P9879 Cable, paper volume	7-49
56P9880 Cable, up/down switch	7-49
56P9882 Motor, HCF DC	7-51
56P9883 Spring, pressure	7-51
56P9884 Belt, timing	7-51
56P9885 Pulley, timing	7-51
56P9886 Gear, drive	7-51
56P9887 Bracket, front idler	7-51
56P9888 Bracket, rear idler	7-51
56P9889 Pad, friction	7-53
56P9890 Plate, paper adhesion	7-53
56P9891 Knob, tray	7-53
56P9892 Plate, upper side fence	7-53
56P9893 Knob, stopper	7-53
56P9894 Fence assembly, rear side	7-53
56P9902 Cassette, heavy media	7-31

56P9905 Kit, operator panel overlay	7-3
56P9910 Card assembly, 128MB SDRAM memory	7-72
56P9911 Card assembly, 256MB SDRAM memory	7-72
56P9912 Card assembly, 4MB Flash DIMM memory	7-72
56P9913 Card assembly, 8MB Flash DIMM memory	7-72
56P9914 Card assembly, 16MB Flash DIMM memory	7-72
56P9915 Fence assembly, front side	7-53
56P9916 Card, riser	7-27
56P9923 Card, ImageQuick (C910)	7-72
56P9925 Card, PRESCRIBE	7-72
56P9926 Software, Opra Forms	7-72
56P9927 Software, Opra Forms Director	7-72
56P9928 DIMM, Lexmark Forms 4MB Flash	7-72
56P9929 DIMM, Lexmark Forms 8MB Flash	7-72
56P9930 DIMM, Lexmark Forms 16MB Flash	7-72
56P9932 Hard Disk, Lexmark Forms	7-73
56P9934 Card, Token-Ring	7-72
56P9935 Traditional Chinese font kit	7-73
56P9936 Simplified Chinese font kit	7-73
56P9940 Ring, snap	7-43
56P9941 Arm, pick-up	7-45
56P9942 Mounting Kit, hard drive	7-73
56P9943 Fuse, thermal (230 V only)	7-23
56P9945 Parts packet	7-3, 7-74
56P9946 Parts packet	7-74
56P9947 Parts packet	7-15, 7-74
56P9948 Parts packet	7-17, 7-75
56P9949 Parts packet	7-19, 7-75
56P9950 Parts packet	7-21, 7-75
56P9951 Parts packet	7-25, 7-76
56P9952 Parts packet	7-27, 7-76
56P9953 Parts packet	7-29, 7-77
56P9954 Parts packet	7-77
56P9955 Parts packet	7-33, 7-77
56P9956 Parts packet	7-37, 7-78
56P9957 Parts packet	7-41, 7-78
56P9958 Parts packet	7-43, 7-78, 7-79
56P9959 Parts packet	7-45, 7-79
56P9960 Parts packet	7-47, 7-79
56P9961 Parts packet	7-49, 7-79
56P9962 Parts packet	7-51, 7-80

5055-xxx

56P9963 Parts packet	7-53, 7-80
56P9964 Transformer, power (Japan only)	7-25
56P9970 Cover assembly, front (C912)	7-3
56P9971 Frame assembly, MPF	7-21
56P9972 Feeder assembly, multipurpose	7-11
56P9973 Board, RIP controller (C912)	7-27
56P9974 Board, RIP controller, network (C912)	7-27
56P9975 Japanese font kit	7-73
56P9976 Board, RIP controller (C910)	7-27
56P9977 Board, RIP controller, network (C910)	7-27
56P9979 Guide, stop	7-31
56P9980 Guard, rack	7-31
56P9981 Board, printer controller (912)—S/N XX-0XXXX	7-23
56P9982 Hard Disk, 5+ GB w/Mounting Kit (formatted)	7-72
56P9985 Printhead, LED K (black)—S/N XX-1XXXX	7-15
56P9986 Printhead, LED Y/M/C (color)—S/N XX-1XXXX	7-15
56P9987 Board, printhead controller—S/N XX-1XXXX	7-13
56P9988 Post, mini—S/N XX-1XXXX	7-15
56P9989 Core, Ferrite—S/N XX-1XXXX	7-15
56P9990 Tape, Core—S/N XX-1XXXX	7-15
56P9991 Cable assembly 48-pin PH controller—S/N XX-1XXXX	7-13
56P9992 Board, printer controller (912)—S/N XX-1XXXX	7-23
56P9993 Shield, light—used on P/N 56P9594 for S/N XX-1XXXX	7-15
56P9994 Plate, duplex guide	7-39
7370516 Kit, printer relocation	7-73
7370567 Kit, duplex relocation	7-73
7370569 Kit, 500-sheet tray relocation	7-73
99A0424 Card, infrared adapter	7-72
99A0545 Card, external serial adapter	7-72
99A0560 Card, Tri-Port adapter	7-72
99A1501 Board operator panel (Japan)	7-3

C91x Finisher Wiring Diagram

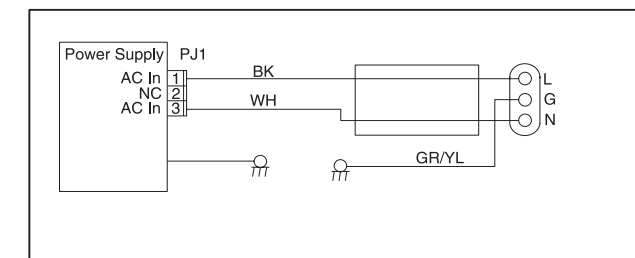
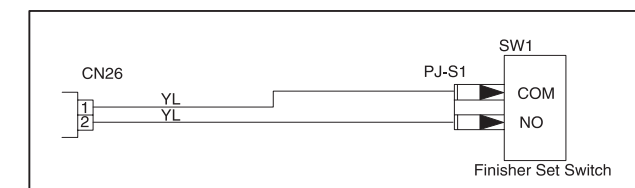
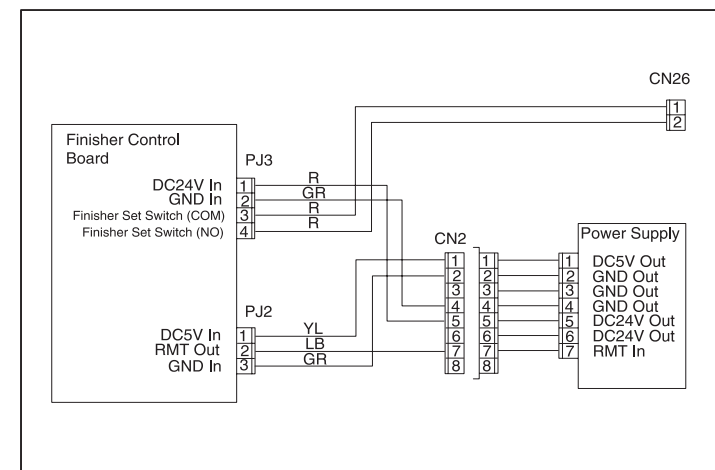
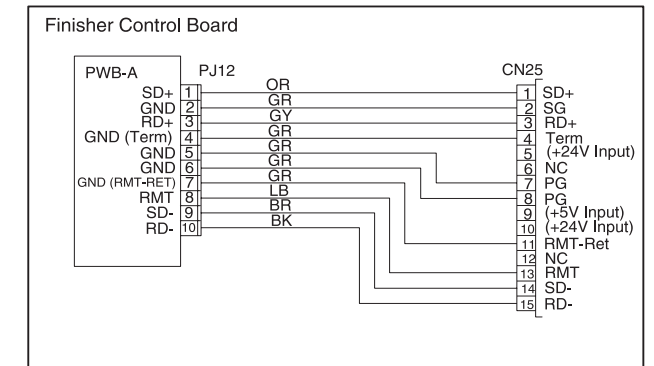
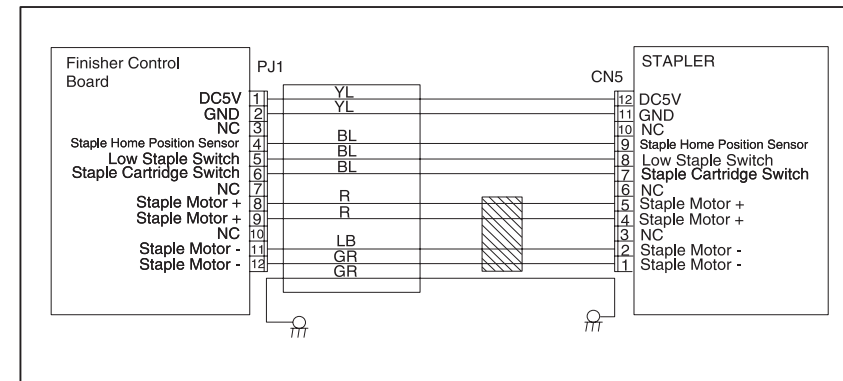
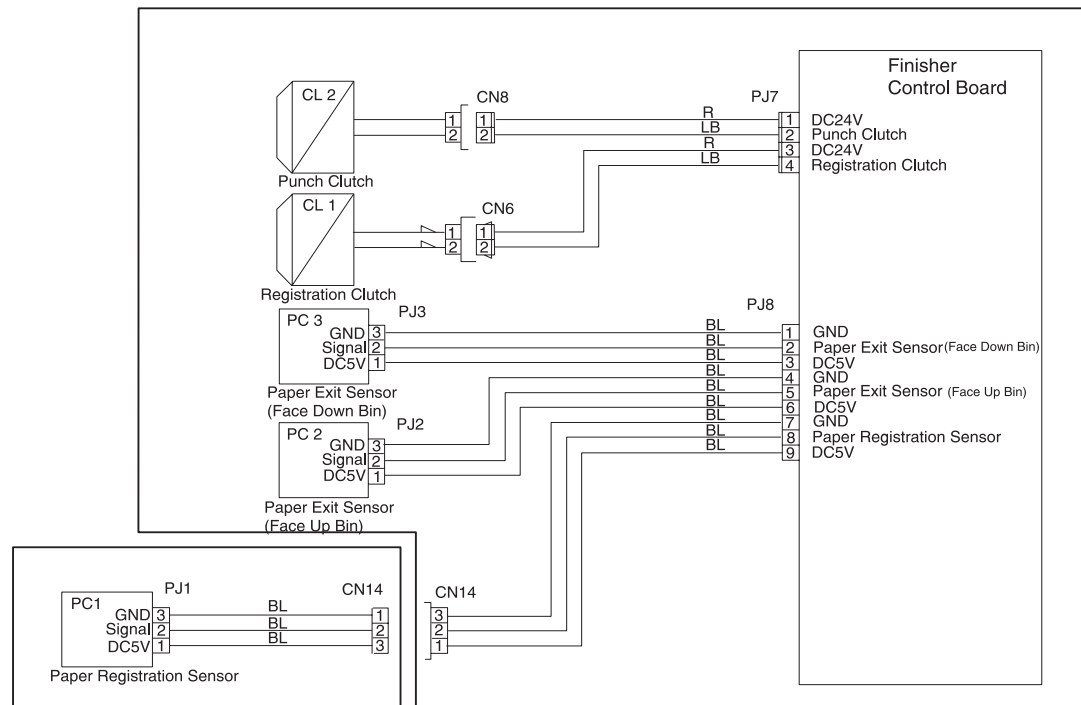
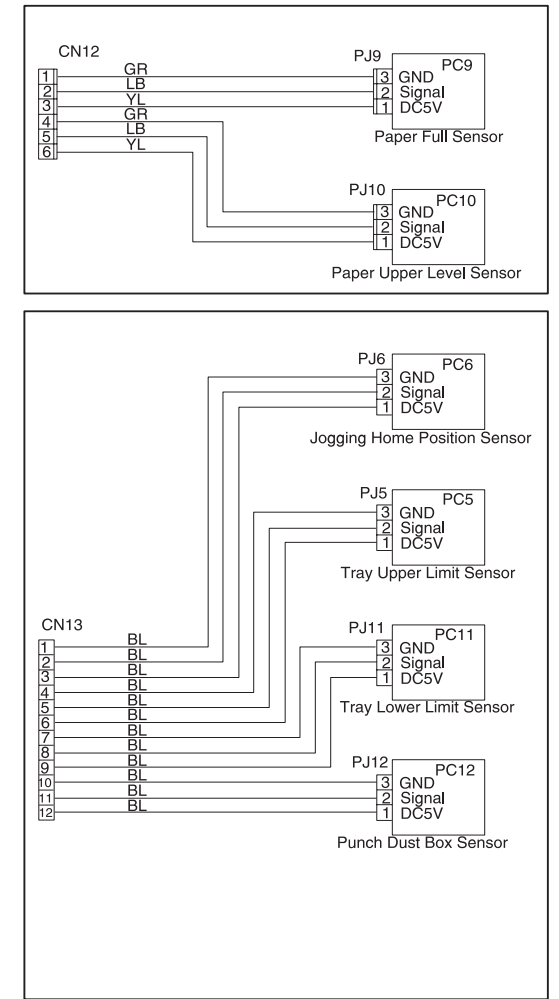
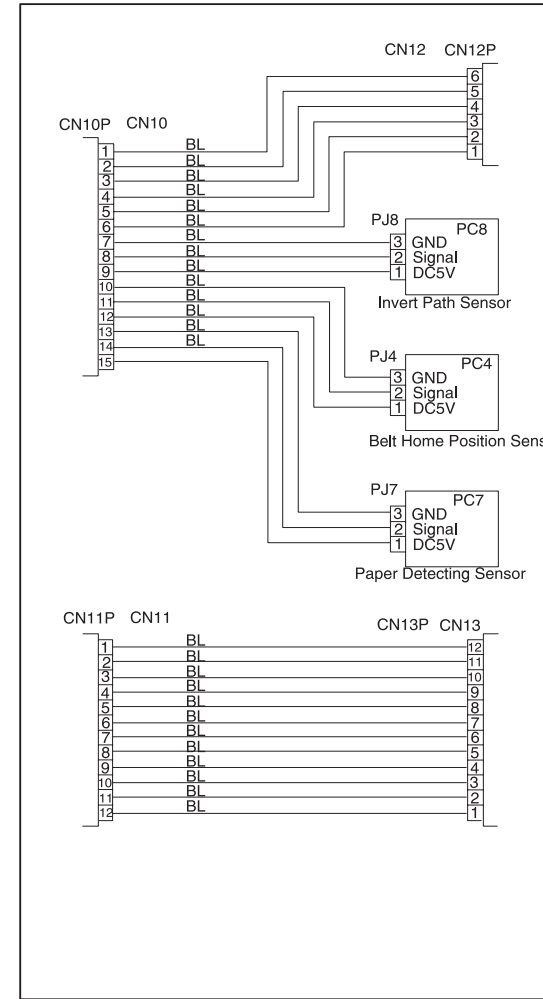
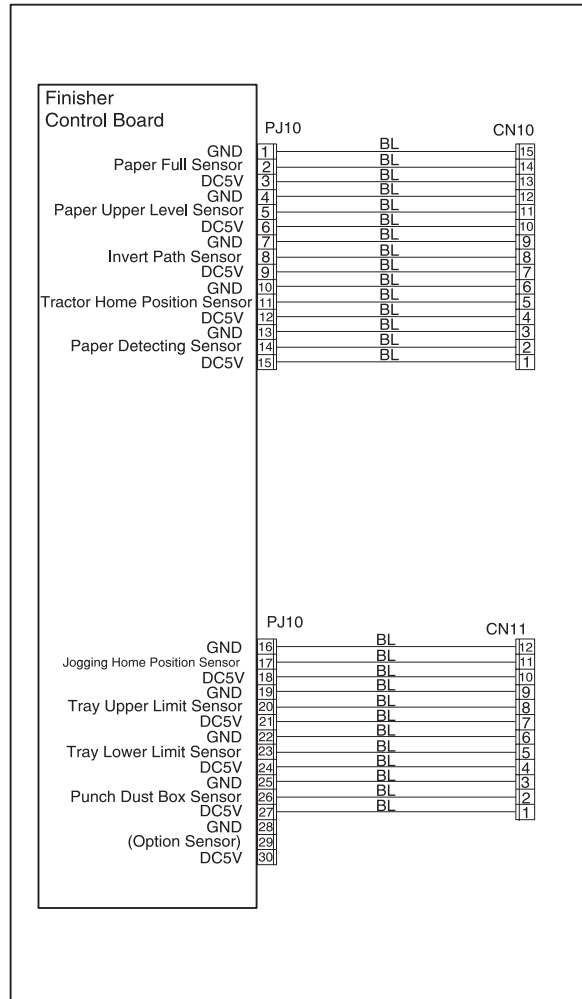
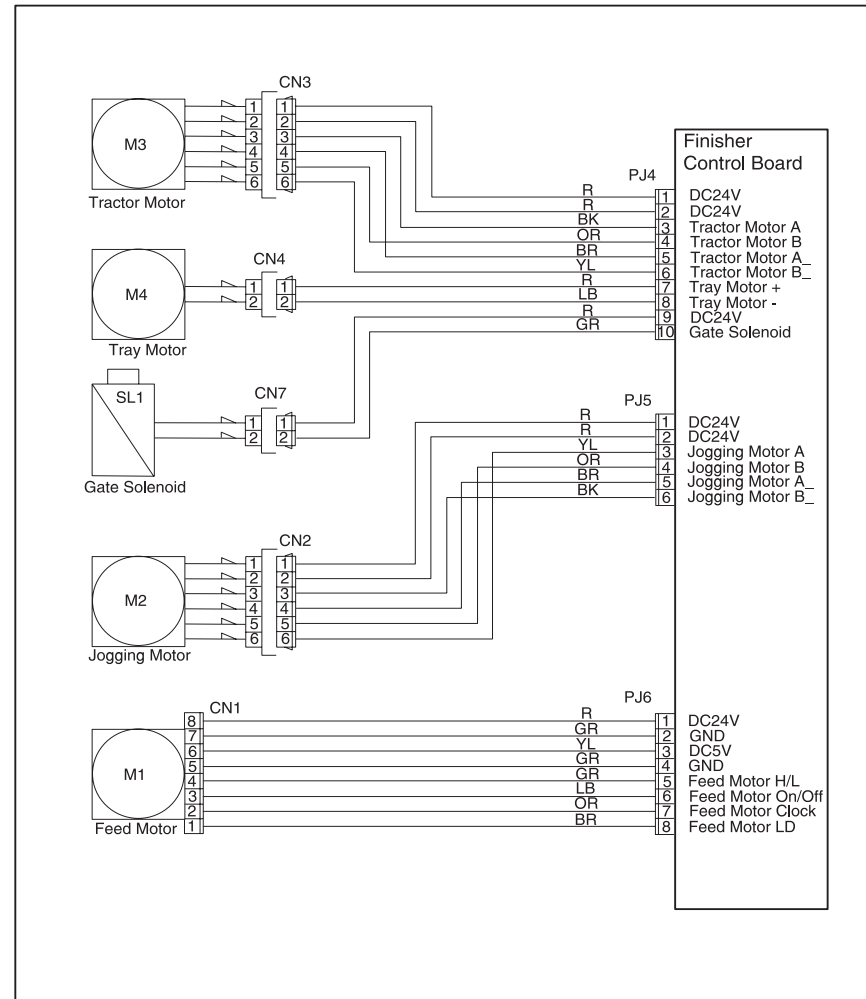

C91x High Capacity Paper Feeder Wiring Diagram

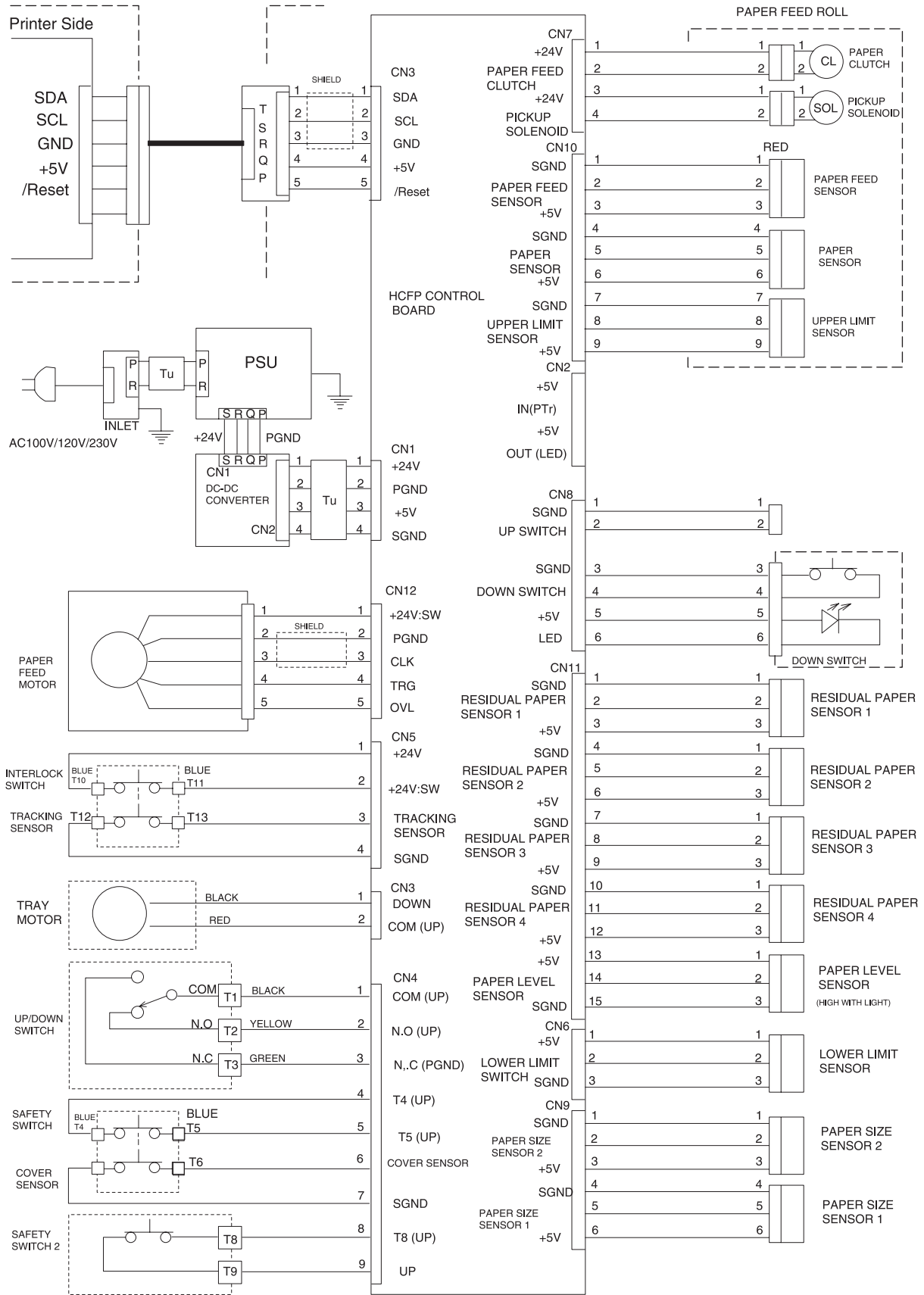

C912 Printer Engine Wiring Diagram (S/Nos. XX - 1XXXX)

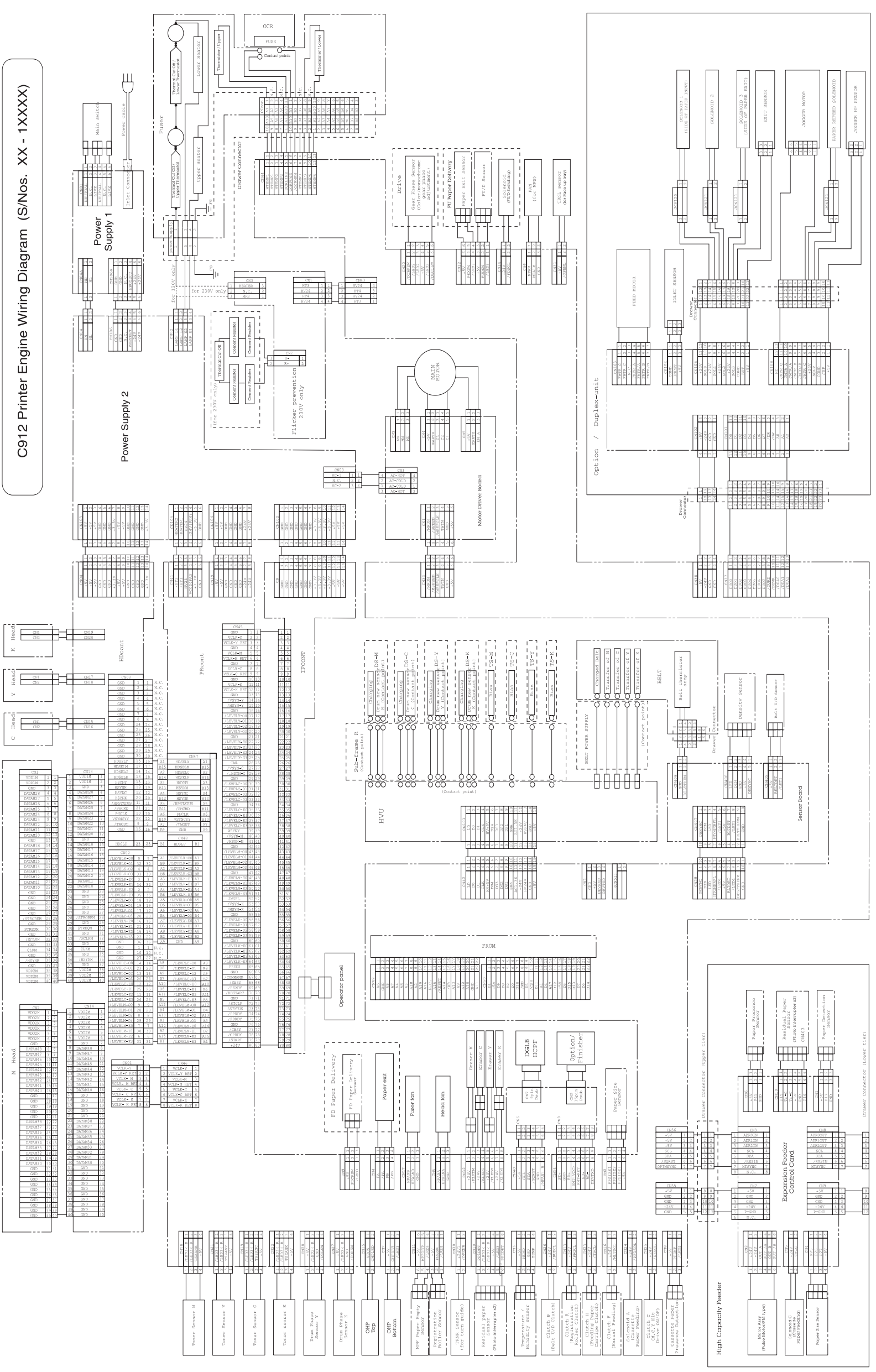

C91X General Circuit Diagram

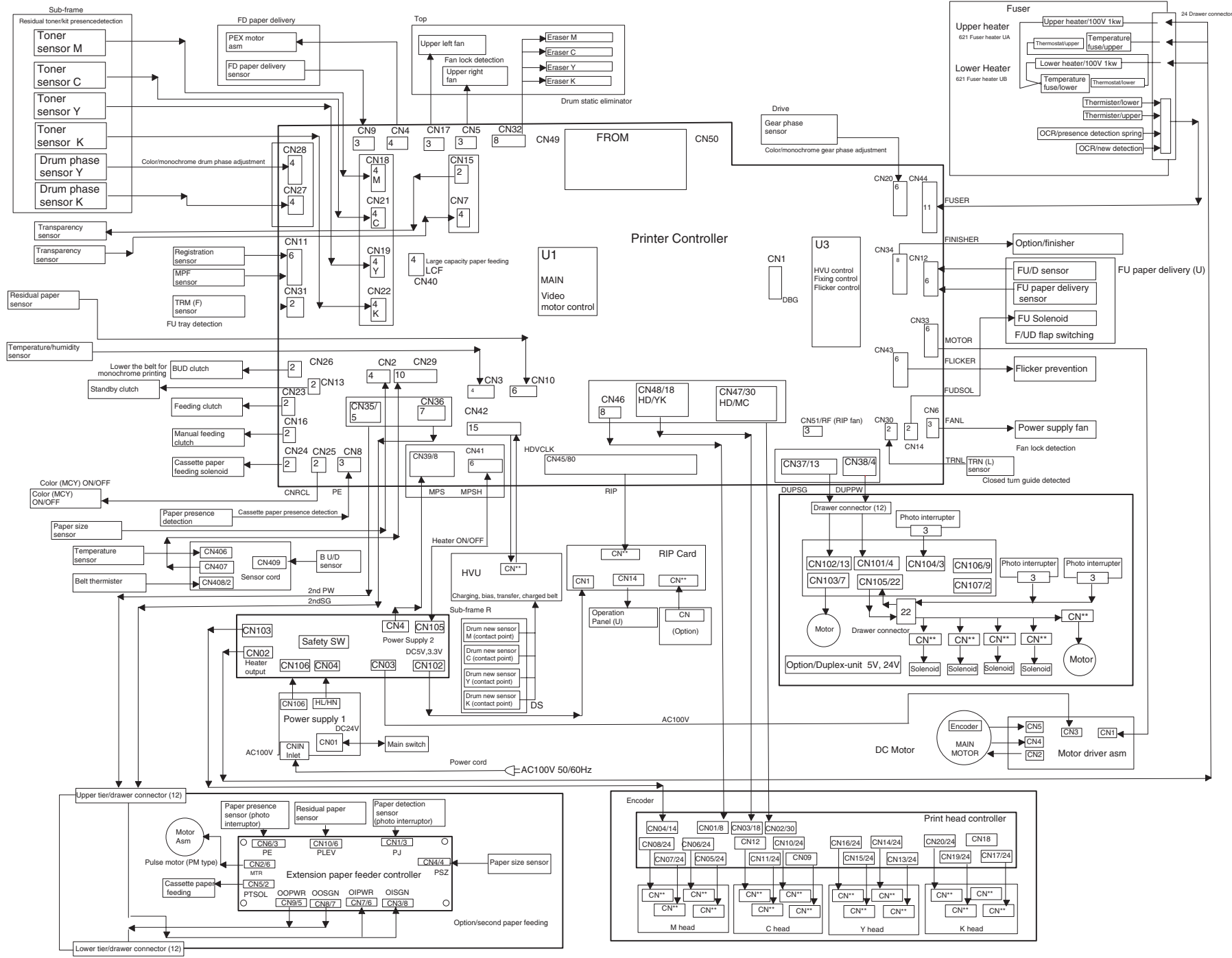

C91x Color Printer Wiring Diagram (S/Nos. XX - 0XXXX)

