

Revised: July 27, 2005



Service Manual

Lexmark™ C750

5060-00x

- ***Table of contents***
- ***Start diagnostics***
- ***Safety and notices***
- ***Trademarks***
- ***Index***

LEXMARK™

Lexmark and Lexmark with diamond design are trademarks of Lexmark International, Inc., registered in the United States and/or other countries.

Edition: July 27, 2005

The following paragraph does not apply to any country where such provisions are inconsistent with local law:
LEXMARK INTERNATIONAL, INC. PROVIDES THIS PUBLICATION "AS IS" WITHOUT WARRANTY OF ANY KIND, EITHER EXPRESS OR IMPLIED, INCLUDING, BUT NOT LIMITED TO, THE IMPLIED WARRANTIES OF MERCHANTABILITY OR FITNESS FOR A PARTICULAR PURPOSE. Some states do not allow disclaimer of express or implied warranties in certain transactions; therefore, this statement may not apply to you.

This publication could include technical inaccuracies or typographical errors. Changes are periodically made to the information herein; these changes will be incorporated in later editions. Improvements or changes in the products or the programs described may be made at any time.

Comments may be addressed to Lexmark International, Inc., Department D22A/032-2, 740 West New Circle Road, Lexington, Kentucky 40550, U.S.A or e-mail at ServiceInfoAndTraining@Lexmark.com. Lexmark may use or distribute any of the information you supply in any way it believes appropriate without incurring any obligation to you. You can purchase additional copies of publications related to this product by calling 1-800-553-9727. In other countries, contact your point of purchase.

Lexmark, Lexmark with diamond design, and MarkNet are trademarks of Lexmark International, Inc., registered in the United States and/or other countries.

ImageQuick, Optra Forms, and PrintCryption are trademarks of Lexmark International, Inc.

LEXFAX is a service mark of Lexmark International, Inc.

PostScript® is a registered trademark of Adobe Systems Incorporated.

PCL® is a registered trademark of the Hewlett-Packard Company.

Other trademarks are the property of their respective owners.

**© 2004 Copyright Lexmark International, Inc.
All rights reserved.**

UNITED STATES GOVERNMENT RIGHTS

This software and any accompanying documentation provided under this agreement are commercial computer software and documentation developed exclusively at private expense.

U.S.A. P/N 12G9174

Table of contents

Notices and safety information	xi
Laser notice	xi
Safety information	xvii
Preface	xx
Definitions	xx
General information	1-1
Tools required for service	1-1
Options and features	1-2
High performance	1-2
Print quality	1-2
Heavy volume reliability	1-2
Automatic calibration	1-2
Resolution	1-3
Toner darkness	1-3
Printer specifications	1-3
Dimensions	1-3
Power and electrical specifications	1-3
Electrical specifications	1-4
Operating clearances	1-4
Fuser web oiler upgrade kit and replacements	1-4
Acoustics	1-5
Environment	1-5
Print speed and performance print speed	1-6
Media specifications	1-7
Acronyms	1-13
Diagnostic information	2-1
Start	2-1
POR (power-on reset) sequence	2-2
Symptom tables	2-3
Symptom table—base printer	2-3
Symptom table—500-sheet drawer option	2-4
Symptom table—HCIT 2000-sheet option	2-4
Symptom table—output expander option	2-5
Symptom table—5-bin mailbox option	2-5
Symptom table—finisher option	2-5
Error code table	2-6
9xx service errors	2-6
1xx service errors	2-9
Sub error code table	2-17
Programming errors - P101 through P116	2-20
Understanding the printer operator panel	2-20
Operator panel buttons	2-20
Color Menu	2-22
Utilities Menu	2-23
2xx Paper jam message table	2-25
User attendance message table	2-28

Service checks	2-42
100 ITU Error	2-42
120 Error code	2-44
121 Error code	2-45
122 Error code	2-46
123 Error code	2-46
124 Error code	2-46
125 Error code	2-47
126 Error code	2-47
127 Error code	2-48
128 Error code	2-48
129 Error code	2-49
130 Error code	2-50
131 Error code	2-51
132 Error code	2-52
133 Error code	2-53
134 Error code	2-54
135 Error code	2-55
136 Error code	2-56
148 Error code	2-57
149 Error code	2-58
150 Error code	2-58
151 Error code	2-59
152 Error code	2-59
153 Error code	2-60
154 Error code	2-61
155 Error code	2-62
156 Error code	2-62
157 Error code	2-63
158 Error code	2-64
159 Error code	2-64
160 Error code	2-65
161 Error code	2-65
162 Error code	2-65
163 Error code	2-66
164 Error code	2-66
165 Error code	2-66
200 Paper jam—Tray 1	2-67
200 Paper jam—Options and envelope feeder	2-69
201 Paper jam	2-71
201 Paper jam	2-72
202 Paper jam	2-73
230 Paper jam	2-76
24x Paper jam	2-77
Printer configuration and 24x paper jam codes	2-77
Printer configuration diagrams for 24x paper jams	2-81
250 Paper jam	2-82
271 Paper jam - Check Bin 1	2-84
272 Paper jam - Check Bin x	2-85
274 Paper jam - Check Bin 4	2-86
280 Paper jam	2-87
900 RIP Software Error	2-88
925 Error code	2-90
926 Error code	2-90
927 Error code	2-91

930 Error code	2-92
940 Error code	2-93
941 Error code	2-95
942 Error code	2-97
943 Error code	2-99
990 Service error	2-101
5-Bin mailbox option service check	2-104
500-Sheet drawer option service check	2-108
AC and DC power service check	2-112
Autocompensator service check	2-114
Black only retract (BOR) service check	2-117
Close door/HVPS/printhead interlock switch service check	2-118
Duplex option service check	2-120
Finisher service check	2-122
Fuser service check	2-127
High-capacity input tray (HCIT) 2000-sheet option service check	2-128
Operator panel LCD/status LED/buttons service check	2-132
Output Expander option service check	2-134
Print quality service checks	2-136
Horizontal line	2-137
Horizontal lines or streaks	2-137
Vertical lines or streaks	2-138
Light lines or streaks appear on the page	2-138
White streak in color plane	2-138
Blank page (no image)	2-139
Entire page is mostly one color—Full bleed planes in one color	2-140
Missing colors—Complete or partially missing color planes	2-141
Black and white only—cyan, magenta, and yellow are missing	2-142
Light print over the entire page	2-142
All colors have light print over the entire page	2-142
One color has light print over the entire page	2-143
Low image density	2-143
Poor color alignment	2-144
Negative ghosting or faded image	2-144
Residual image	2-145
Uneven printing	2-145
Toner smears or rubs off the page with no error code displayed	2-145
Smudged or distorted images on fused page	2-146
Toner is on the back of the printed page	2-146
Transparency print quality is poor	2-147
Second transfer roll service check	2-148
Tray 1 service check	2-149
Tray 1 paper size sensing service check	2-150
Diagnostic aids	3-1
Diagnostic aids	3-1
Printhead diagnostics	3-1
Print quality defect locator chart	3-3
Partial Print Test	3-5
Configuration Menu	3-7
Entering CONFIG MENU	3-7
Black&White Lock	3-7
Fuser Cnt Value	3-7
Reset Fuser Cnt	3-8
Prt Quality Pgs	3-8
Color Trapping	3-8

SIZE SENSING	3-8
TYPE SENSING	3-9
SENSED TRANS	3-9
SENSED PAPER	3-9
CALIBRATE TRAYS	3-9
Panel Menus	3-10
PPDS Emulation	3-10
Download Emuls	3-10
Demo Mode	3-10
Factory Defaults	3-11
Energy Conserve	3-11
ITU Alignment	3-11
Auto Color Adjust	3-12
Exit Config Menu	3-12
Diagnostics Mode	3-13
Entering Diagnostics Mode	3-13
Exiting Diagnostics Mode	3-13
REGISTRATION	3-14
ALIGNMENT	3-15
Cyan, Yellow, Magenta	3-15
Drift Sensors	3-16
To exit the test, press Return or Stop.	3-16
TOP FINE MAR ADJ	3-16
MISC TESTS	3-16
Motor Detect	3-16
Belt Tracking (ITU 4th point adjustment)	3-17
PRINT TESTS	3-18
Print Tests (input source)	3-18
Prt Quality Pgs	3-19
Prt Line Len Pg	3-19
HARDWARE TESTS	3-19
LCD Test	3-19
Button Test	3-19
DRAM Test	3-20
CACHE Test	3-20
ROM Test	3-21
Parallel Wrap Test	3-21
Serial Wrap Test	3-22
DUPLEX TESTS	3-23
Quick Test	3-23
Top Margin	3-23
Sensor Test	3-23
INPUT TRAY TESTS	3-24
Feed Test	3-24
Sensor Test	3-24
OUTPUT BIN TESTS	3-25
Feed Test	3-25
Feed to All Bins	3-25
Diverter Test	3-25
Sensor Test	3-26
FINISHER TESTS	3-27
Staple Test	3-27
Feed Test	3-27
Sensor Test	3-27
Hole Punch	3-28
BASE SENSOR TEST	3-29

DEVICE TESTS	3-29
Quick Disk Test	3-29
Disk Test/Clean	3-29
Flash Test	3-30
PRINTER SETUP	3-30
Defaults	3-30
Reset Calibrat.	3-31
Page Count	3-31
Perm Page Count	3-31
Serial Number	3-31
Engine Setting x	3-31
Model Name	3-32
Configuration ID	3-32
Edge to Edge	3-32
Cal Ref Adj	3-32
EP SETUP	3-32
EP Defaults	3-32
Fuser Temp	3-32
DC Charge Adjust	3-32
Dev Bias Adj	3-33
Transfer Adjust	3-33
ERROR LOG	3-33
View Log	3-33
Clear Log	3-33
High-capacity input tray tests	3-34
HCIT Standalone Test Mode	3-34
Dip Switch Settings	3-34
Repair information	4-1
Handling ESD-sensitive parts	4-1
Screw identification table	4-2
Removal procedures	4-5
Top cover assembly removal	4-5
Rear fan cover removal	4-8
Rear cover removal	4-8
Front right handle cover assembly removal	4-9
Front left handle cover assembly removal	4-10
Front cover assembly removal	4-10
Lower right door assembly removal	4-12
Left lower cover removal	4-13
Lower jam access door assembly removal	4-14
Redrive door removal	4-14
Paper path access door cover removal	4-15
Front lower left cover removal	4-16
Autocompensator pick assembly removal	4-17
BOR drive assembly removal	4-23
Cartridge contact assembly removal	4-23
Cartridge drive assembly removal	4-26
Cartridge rail assembly	4-27
Developer HVPS board removal	4-28
Engine board removal	4-29
Engine board shield removal	4-30
Friction buckler removal	4-30
Fuser assembly removal	4-31
Fuser bottom duct removal	4-32
Fuser drive assembly removal	4-33

Fuser fan removal 4-34

Fuser top duct removal 4-34

Fuser web oiler motor assembly removal 4-35

ITU assembly removal 4-37

ITU drive assembly removal 4-37

ITU drive motor removal 4-38

Low voltage power supply (LVPS) removal 4-38

Multipurpose feeder (MPF) removal 4-40

Nip relief handle removal 4-42

Operator panel removal 4-46

Outer EMC shield removal 4-47

Paper size sensing assembly removal 4-48

Pick rolls 4-48

Printhead removal and adjustment 4-50

 Printhead mechanical alignment 4-51

 Printer registration (only for black printhead replacement) 4-56

 Electronic color alignment 4-58

 Print line length calibration 4-61

Printhead thermistor card removal 4-62

PSD sensor assembly removal 4-63

Rear bellcrank removal (cyan, magenta, yellow) 4-64

Rear bellcrank removal (black) 4-66

Redrive assembly removal 4-68

Registration motor removal 4-69

RIP board removal 4-70

RIP fan removal 4-71

RIP board shield assembly removal 4-71

S2/NMS/transparency sensor assembly removal 4-72

Second transfer roll removal 4-79

Transfer HVPS board removal 4-80

Transfer plate assembly 4-81

Vacuum transport belt (VTB) removal 4-82

Vacuum transport belt (VTB) fan removal 4-84

Waste container door removal 4-84

Waste container latch removal 4-85

Web oiler fuser kit installation 4-85

Connector locations 5-1

Locations 5-1

Printer boards 5-1

Printer motors 5-2

Printer sensors 5-3

Cartridge contact assembly pin locations 5-4

Engine board cabling 5-5

RIP board cabling 5-6

Connectors 5-7

Engine board 5-7

RIP board 5-14

Transfer high voltage power supply (HVPS) 5-19

Developer high voltage power supply (HVPS) board 5-20

Low voltage power supply (LVPS) 5-22

Low voltage power supply (LVPS) 5-24

High-capacity input tray (2000-sheet HCIT) board	5-26
High-capacity output finisher (HCOF)	5-28
HCOF LVPS board	5-28
HCOF SUB LVPS relay board	5-28
HCOF system board	5-29
Preventive maintenance	6-1
Safety inspection guide	6-1
Lubrication specifications	6-1
Lubrication for replacement motors	6-2
Fuser drive assembly	6-2
Cartridge drive assembly	6-3
ITU drive assembly	6-3
Scheduled maintenance	6-4
Parts catalog	7-1
How to use this parts catalog	7-1
Assembly 1: Covers	7-2
Assembly 2: Cartridge mounting	7-6
Assembly 3: Fuser	7-8
Assembly 4: Fuser drive	7-12
Assembly 5: Vacuum transport belt assembly	7-13
Assembly 6: Transfer	7-14
Assembly 7: Printheads	7-15
Assembly 8: Paper feed output (redrive)	7-16
Assembly 9: Paper feed input	7-17
Assembly 10: Paper size sensing	7-18
Assembly 11: Paper feed transport	7-19
Assembly 12: Multipurpose feeder (MPF)	7-20
Assembly 13: 500-sheet integrated tray	7-22
Assembly 14: Autocompensator assembly	7-24
Assembly 15: ITU assembly	7-25
Assembly 16: ITU drive assembly	7-26
Assembly 17: ITU loading	7-28
Assembly 18: BOR drive assembly	7-30
Assembly 19: Cartridge contact assembly	7-31
Assembly 20: Cartridge drive assembly	7-32
Assembly 21: Electronics	7-34
Assembly 22: Electronic cabling—engine board	7-42
Assembly 23: Electronic cabling—RIP board	7-44
Assembly 24: Electronic cabling—transfer HVPS	7-46
Assembly 25: Electronic cabling—developer HVPS	7-47
Assembly 26: Output expander	7-48
Assembly 27: 5-bin mailbox	7-52
Assembly 28: 500-sheet drawer option	7-56
Assembly 29: Duplex option	7-60
Assembly 30: High-capacity input tray (HCIT)	7-64
Assembly 31: High-capacity output finisher (HCOF)	7-68
Assembly 32: High-capacity output finisher cables	7-74
Assembly 33: Options	7-76
Assembly 34: Miscellaneous	7-77

- Appendix A—Service tips.A-1**
 - Printhead diagnosticsA-1**
 - Printhead alignment.A-4**
 - Identifying the printheads A-4
 - Printhead mechanical alignment A-5
 - Printer registration (only for black printhead replacement) A-10
 - Electronic color alignment A-12
 - Print line length calibration A-14
 - Partial Print Test.A-16**
 - Nip relief handle replacementA-18**
 - Finisher alignmentA-22**
 - Duplex option deflector button replacement.A-29**
- Appendix B—Print quality samples.B-1**
 - Print Menus—Page one of twoB-1**
 - Print Menus—Page two of two B-2
 - Print testsB-3**
 - Print Quality Pages—Title page (total of five) B-3
 - Print Quality Pages—Page 1 (total of five) B-4
 - Print Quality Pages—Page 2 (total of five) B-5
 - Print Quality Pages—Page 3 (total of five) B-6
 - Print Quality Pages—Page 4 (total of five) B-7
 - Registration.B-8**
 - Quick Test B-8
 - Alignment test pagesB-9**
 - Printhead alignment test pages—magenta (one of three) B-9
 - Printhead alignment test page—yellow (two of three) B-10
 - Printhead alignment test page—cyan (three of three) B-11
 - Print Line Len page B-12
- IndexI-1**
- Part number indexI-7**

Notices and safety information

Laser notice

The printer is certified in the U.S. to conform to the requirements of DHHS 21 CFR Subchapter J for Class I (1) laser products, and elsewhere is certified as a Class I laser product conforming to the requirements of IEC 60825-1.

Class I laser products are not considered to be hazardous. The printer contains internally a Class IIIb (3b) laser that is nominally a 5 milliwatt gallium arsenide laser operating in the wavelength region of 770-795 nanometers. The laser system and printer are designed so there is never any human access to laser radiation above a Class I level during normal operation, user maintenance, or prescribed service condition.

Laser

Der Drucker erfüllt gemäß amtlicher Bestätigung der USA die Anforderungen der Bestimmung DHHS (Department of Health and Human Services) 21 CFR Teil J für Laserprodukte der Klasse I (1). In anderen Ländern gilt der Drucker als Laserprodukt der Klasse I, der die Anforderungen der IEC (International Electrotechnical Commission) 60825-1 gemäß amtlicher Bestätigung erfüllt.

Laserprodukte der Klasse I gelten als unschädlich. Im Inneren des Druckers befindet sich ein Laser der Klasse IIIb (3b), bei dem es sich um einen Galliumarsenlaser mit 5 Milliwatt handelt, der Wellen der Länge 770-795 Nanometer ausstrahlt. Das Lasersystem und der Drucker sind so konzipiert, daß im Normalbetrieb, bei der Wartung durch den Benutzer oder bei ordnungsgemäßer Wartung durch den Kundendienst Laserbestrahlung, die die Klasse I übersteigen würde, Menschen keinesfalls erreicht.

Avis relatif à l'utilisation de laser

Pour les Etats-Unis : cette imprimante est certifiée conforme aux provisions DHHS 21 CFR alinéa J concernant les produits laser de Classe I (1). Pour les autres pays : cette imprimante répond aux normes IEC 60825-1 relatives aux produits laser de Classe I.

Les produits laser de Classe I sont considérés comme des produits non dangereux. Cette imprimante est équipée d'un laser de Classe IIIb (3b) (arséniure de gallium d'une puissance nominale de 5 milliwatts) émettant sur des longueurs d'onde comprises entre 770 et 795 nanomètres. L'imprimante et son système laser sont conçus pour impossible, dans des conditions normales d'utilisation, d'entretien par l'utilisateur ou de révision, l'exposition à des rayonnements laser supérieurs à des rayonnements de Classe I.

Avvertenze sui prodotti laser

Questa stampante è certificata negli Stati Uniti per essere conforme ai requisiti del DHHS 21 CFR Sottocapitolo J per i prodotti laser di classe 1 ed è certificata negli altri Paesi come prodotto laser di classe 1 conforme ai requisiti della norma CEI 60825-1.

I prodotti laser di classe non sono considerati pericolosi. La stampante contiene al suo interno un laser di classe IIIb (3b) all'arseniuro di gallio della potenza di 5mW che opera sulla lunghezza d'onda compresa tra 770 e 795 nanometri. Il sistema laser e la stampante sono stati progettati in modo tale che le persone a contatto con la stampante, durante il normale funzionamento, le operazioni di servizio o quelle di assistenza tecnica, non ricevano radiazioni laser superiori al livello della classe 1.

Avisos sobre el láser

Se certifica que, en los EE.UU., esta impresora cumple los requisitos para los productos láser de Clase I (1) establecidos en el subcapítulo J de la norma CFR 21 del DHHS (Departamento de Sanidad y Servicios) y, en los demás países, reúne todas las condiciones expuestas en la norma IEC 60825-1 para productos láser de Clase I (1).

Los productos láser de Clase I no se consideran peligrosos. La impresora contiene en su interior un láser de Clase IIIb (3b) de arseniuro de galio de funcionamiento nominal a 5 milivatios en una longitud de onda de 770 a 795 nanómetros. El sistema láser y la impresora están diseñados de forma que ninguna persona pueda verse afectada por ningún tipo de radiación láser superior al nivel de la Clase I durante su uso normal, el mantenimiento realizado por el usuario o cualquier otra situación de servicio técnico.

Declaração sobre Laser

A impressora está certificada nos E.U.A. em conformidade com os requisitos da regulamentação DHHS 21 CFR Subcapítulo J para a Classe I (1) de produtos laser. Em outros locais, está certificada como um produto laser da Classe I, em conformidade com os requisitos da norma IEC 60825-1.

Os produtos laser da Classe I não são considerados perigosos. Internamente, a impressora contém um produto laser da Classe IIIb (3b), designado laser de arseneto de potássio, de 5 milliwatts, operando numa faixa de comprimento de onda entre 770 e 795 nanómetros. O sistema e a impressora laser foram concebidos de forma a nunca existir qualquer possibilidade de acesso humano a radiação laser superior a um nível de Classe I durante a operação normal, a manutenção feita pelo utilizador ou condições de assistência prescritas.

Laserinformatie

De printer voldoet aan de eisen die gesteld worden aan een laserproduct van klasse I. Voor de Verenigde Staten zijn deze eisen vastgelegd in DHHS 21 CFR Subchapter J, voor andere landen in IEC 60825-1.

Laserprodukten van klasse I worden niet als ongevaarlijk aangemerkt. De printer is voorzien van een laser van klasse IIIb (3b), dat wil zeggen een gallium arsenide-laser van 5 milliwatt met een golflengte van 770-795 nanometer. Het lasergedeelte en de printer zijn zo ontworpen dat bij normaal gebruik, bij onderhoud of reparatie conform de voorschriften, nooit blootstelling mogelijk is aan laserstraling boven een niveau zoals voorgeschreven is voor klasse 1.

Lasermeddelelse

Printeren er godkendt som et Klasse I-laserprodukt, i overensstemmelse med kravene i IEC 60825-1.

Klasse I-laserprodukter betragtes ikke som farlige. Printeren indeholder internt en Klasse IIIB (3b)-laser, der nominelt er en 5 milliwatt galliumarsenid laser, som arbejder på bølgelængdeområdet 770-795 nanometer. Lasersystemet og printeren er udformet således, at mennesker aldrig udsættes for en laserstråling over Klasse I-niveau ved normal drift, brugervedligeholdelse eller obligatoriske servicebetingelser.

Huomautus laserlaitteesta

Tämä kirjoitin on Yhdysvalloissa luokan I (1) laserlaitteiden DHHS 21 CFR Subchapter J -määrityksen mukainen ja muualla luokan I laserlaitteiden IEC 60825-1 -määrityksen mukainen.

Luokan I laserlaitteiden ei katsota olevan vaarallisia käyttäjälle. Kirjoittimessa on sisäinen luokan IIIb (3b) 5 milliwatin galliumarsenidilaser, joka toimii aaltoalueella 770 - 795 nanometriä. Laserjärjestelmä ja kirjoitin on suunniteltu siten, että käyttäjä ei altistu luokan I määräyksiä voimakkaammalle säteilylle kirjoittimen normaalin toiminnan, käyttäjän tekemien huoltotoimien tai muiden huoltotoimien yhteydessä.

VARO! Avattaessa ja suojalukitus ohitettaessa olet alltiina näkymättömälle lasersäteilylle. Älä katso säteeseen.

WARNING! Osynlig laserstrålning när denna del är öppnad och spårren är urkopplad. Betrakta ej strålen.

Laser-notis

Denna skrivare är i USA certifierad att motsvara kraven i DHHS 21 CFR, underparagraf J för laserprodukter av Klass I (1). I andra länder uppfyller skrivaren kraven för laserprodukter av Klass I enligt kraven i IEC 60825-1.

Laserprodukter i Klass I anses ej hälsovådliga. Skrivaren har en inbyggd laser av Klass IIIb (3b) som består av en laserenhet av gallium-arsenid på 5 milliwatt som arbetar i våglängdsområdet 770-795 nanometer. Lasersystemet och skrivaren är utformade så att det aldrig finns risk för att någon person utsätts för laserstrålning över Klass I-nivå vid normal användning, underhåll som utförs av användaren eller annan föreskriven serviceåtgärd.

Laser-melding

Skriveren er godkjent i USA etter kravene i DHHS 21 CFR, underkapittel J, for klasse I (1) laserprodukter, og er i andre land godkjent som et Klasse I-laserprodukt i samsvar med kravene i IEC 60825-1.

Klasse I-laserprodukter er ikke å betrakte som farlige. Skriveren inneholder internt en klasse IIIb (3b)-laser, som består av en gallium-arsenlaserenhet som avgir stråling i bølgelengdeområdet 770-795 nanometer. Lasersystemet og skriveren er utformet slik at personer aldri utsettes for laserstråling ut over klasse I-nivå under vanlig bruk, vedlikehold som utføres av brukeren, eller foreskrevne serviceoperasjoner.

Avís sobre el Làser

Segons ha estat certificat als Estats Units, aquesta impressora compleix els requisits de DHHS 21 CFR, apartat J, pels productes làser de classe I (1), i segons ha estat certificat en altres llocs, és un producte làser de classe I que compleix els requisits d'IEC 60825-1.

Els productes làser de classe I no es consideren perillosos. Aquesta impressora conté un làser de classe IIIb (3b) d'arseniür de gal.li, nominalment de 5 mil.liwats, i funciona a la regió de longitud d'ona de 770-795 nanòmetres. El sistema làser i la impressora han sigut concebutos de manera que mai hi hagi exposició a la radiació làser per sobre d'un nivell de classe I durant una operació normal, durant les tasques de manteniment d'usuari ni durant els serveis que satisfacin les condicions prescrites.

レーザーに関するお知らせ

このプリンターは、米国ではDHHS 21 CFRサブチャプターJのクラスI (1)の基準を満たしたレーザー製品であることが証明されています。また米国以外ではIEC 825の基準を満たしたクラスIのレーザー製品であることが証明されています。

クラスIのレーザー製品には危険性はないと考えられています。このプリンターはクラスIII b (3 b)のレーザーを内蔵しています。このレーザーは、波長が770 ~ 795ナノメートルの範囲で、通常5ミリワットのガリウム砒化物を放射するレーザーです。このレーザーシステムとプリンターは、通常の操作、ユーザのメンテナンス、規定された修理においては、人体がクラスIのレベル以上のレーザー放射に晒されることのないよう設計されています。

注意：

本打印机被美国认证合乎 DHHS 21 CFR Subchapter I 对分类 I (1) 激光产品的标准，而在其他地区则被认证合乎 IEC 825 的标准。

分类 I 激光产品一般认为不具危险性，本打印机内部含有分类 IIIb (3b) 的激光，在操作过程中会产生 5 毫瓦含镓及砷的微量激光，其波长范围在 770-795 nm 之间。本激光系统及打印机的设计，在一般操作、使用者维护或规定内的维修情况下，不会使人体接触分类 I 以上等级的辐射。

본프린터는 1등급 레이저 제품들에 대한 DHHS 21 CFR Subchapter 3의 규정을 준수하고 있음을 미국에서 인증받았으며, 그외의 나라에서도 IEC 825 규정을 준수하는 1등급 레이저 제품으로서 인증을 받았습니다.

1등급 레이저 제품들은 안전한 것으로 간주됩니다. 본 프린터는 5 밀리와트 갈륨 아르세나이드 레이저로서 770-795 나노미터의 파장대에서 활동하는 Class III (3b) 레이저를 내부에 갖고 있습니다. 본 레이저 시스템과 프린터는 정상 작동 중이나 유지 보수 중 또는 규정된 서비스 상태에서 상기의 Class I 수준의 레이저 방출에 사람이 절대 접근할 수 없도록 설계되어 있습니다.

Safety information

- The safety of this product is based on testing and approvals of the original design and specific components. The manufacturer is not responsible for safety in the event of use of unauthorized replacement parts.
- The maintenance information for this product has been prepared for use by a professional service person and is not intended to be used by others.
- There may be an increased risk of electric shock and personal injury during disassembly and servicing of this product. Professional service personnel should understand this and take necessary precautions.
-  **CAUTION:** When you see this symbol, there is a danger from hazardous voltage in the area of the product where you are working. Unplug the product before you begin, or use caution if the product must receive power in order to perform the task.

Consignes de sécurité

- La sécurité de ce produit repose sur des tests et des agréments portant sur sa conception d'origine et sur des composants particuliers. Le fabricant n'assume aucune responsabilité concernant la sécurité en cas d'utilisation de pièces de rechange non agréées.
- Les consignes d'entretien et de réparation de ce produit s'adressent uniquement à un personnel de maintenance qualifié.
- Le démontage et l'entretien de ce produit pouvant présenter certains risques électriques, le personnel d'entretien qualifié devra prendre toutes les précautions nécessaires.
-  **ATTENTION :** Ce symbole indique la présence d'une tension dangereuse dans la partie du produit sur laquelle vous travaillez. Débranchez le produit avant de commencer ou faites preuve de vigilance si l'exécution de la tâche exige que le produit reste sous tension.

Norme di sicurezza

- La sicurezza del prodotto si basa sui test e sull'approvazione del progetto originale e dei componenti specifici. Il produttore non è responsabile per la sicurezza in caso di sostituzione non autorizzata delle parti.
- Le informazioni riguardanti la manutenzione di questo prodotto sono indirizzate soltanto al personale di assistenza autorizzato.
- Durante lo smontaggio e la manutenzione di questo prodotto, il rischio di subire scosse elettriche e danni alla persona è più elevato. Il personale di assistenza autorizzato deve, quindi, adottare le precauzioni necessarie.
-  **ATTENZIONE:** Questo simbolo indica la presenza di tensione pericolosa nell'area del prodotto. Scollegare il prodotto prima di iniziare o usare cautela se il prodotto deve essere alimentato per eseguire l'intervento.

Sicherheitshinweise

- Die Sicherheit dieses Produkts basiert auf Tests und Zulassungen des ursprünglichen Modells und bestimmter Bauteile. Bei Verwendung nicht genehmigter Ersatzteile wird vom Hersteller keine Verantwortung oder Haftung für die Sicherheit übernommen.
- Die Wartungsinformationen für dieses Produkt sind ausschließlich für die Verwendung durch einen Wartungsfachmann bestimmt.
- Während des Auseinandernehmens und der Wartung des Geräts besteht ein zusätzliches Risiko eines elektrischen Schlags und körperlicher Verletzung. Das zuständige Fachpersonal sollte entsprechende Vorsichtsmaßnahmen treffen.
-  **ACHTUNG:** Dieses Symbol weist auf eine gefährliche elektrische Spannung hin, die in diesem Bereich des Produkts auftreten kann. Ziehen Sie vor den Arbeiten am Gerät den Netzstecker des Geräts, bzw. arbeiten Sie mit großer Vorsicht, wenn das Produkt für die Ausführung der Arbeiten an den Strom angeschlossen sein muß.

Pautas de Seguridad

- La seguridad de este producto se basa en pruebas y aprobaciones del diseño original y componentes específicos. El fabricante no es responsable de la seguridad en caso de uso de piezas de repuesto no autorizadas.
- La información sobre el mantenimiento de este producto está dirigida exclusivamente al personal cualificado de mantenimiento.
- Existe mayor riesgo de descarga eléctrica y de daños personales durante el desmontaje y la reparación de la máquina. El personal cualificado debe ser consciente de este peligro y tomar las precauciones necesarias.
-  **PRECAUCIÓN:** este símbolo indica que el voltaje de la parte del equipo con la que está trabajando es peligroso. Antes de empezar, desenchufe el equipo o tenga cuidado si, para trabajar con él, debe conectarlo.

Informações de Segurança

- A segurança deste produto baseia-se em testes e aprovações do modelo original e de componentes específicos. O fabricante não é responsável pela segurança, no caso de uso de peças de substituição não autorizadas.
- As informações de segurança relativas a este produto destinam-se a profissionais destes serviços e não devem ser utilizadas por outras pessoas.
- Risco de choques eléctricos e ferimentos graves durante a desmontagem e manutenção deste produto. Os profissionais destes serviços devem estar avisados deste facto e tomar os cuidados necessários.
-  **CUIDADO:** Quando vir este símbolo, existe a possível presença de uma potencial tensão perigosa na zona do produto em que está a trabalhar. Antes de começar, desligue o produto da tomada eléctrica ou seja cuidadoso caso o produto tenha de estar ligado à corrente eléctrica para realizar a tarefa necessária.

Informació de Seguretat

- La seguretat d'aquest producte es basa en l'avaluació i aprovació del disseny original i els components específics.
El fabricant no es fa responsable de les qüestions de seguretat si s'utilitzen peces de recanvi no autoritzades.
- La informació pel manteniment d'aquest producte està orientada exclusivament a professionals i no està destinada a ningú que no ho sigui.
- El risc de xoc elèctric i de danys personals pot augmentar durant el procés de desmuntatge i de servei d'aquest producte. El personal professional ha d'estar-ne assabentat i prendre les mesures convenients.
-  **PRECAUCIÓ:** aquest símbol indica que el voltatge de la part de l'equip amb la qual esteu treballant és perillós. Abans de començar, desendolieu l'equip o extremeu les precaucions si, per treballar amb l'equip, l'heu de connectar.

안전 사항

- 본 제품은 원래 설계 및 특정 구성품에 대한 테스트 결과로 안정성이 입증된 것입니다. 따라서 무허가 교체부품을 사용하는 경우에는 제조업체에서 안전에 대한 책임을 지지 않습니다.
- 본 제품에 관한 유지 보수 설명서는 전문 서비스 기술자용으로 작성된 것이므로, 비전문가는 사용할 수 없습니다.
- 본 제품을 해체하거나 정비할 경우, 전기적인 충격을 받거나 상처를 입을 위험이 커집니다. 전문 서비스 기술자는 이 사실을 숙지하고, 필요한 예방 조치를 취하도록 하십시오.
-  **주의:** 이 표시는 해당영역에서 고압전류가 흐른다는 위험 표시입니다. 시작전에 플러그를 뽑으시거나, 주의를 기울여 주시기 바랍니다.

安全信息

本产品的安全性以原来设计和特定产品的测试结果和认证为基础。万一使用未经许可的替换部件，制造商不对安全性负责。

本产品的维护信息仅供专业服务人员使用，并不打算让其他人使用。

本产品在拆卸、维修时，遭受电击或人员受伤的危险性会增高，专业服务人员对这点必须有所了解，并采取必要的预防措施。



切记: 当您看到此符号时，说明在您工作的产品区域有危险电压的存在。请在开始操作前拔掉产品的电源线，或者在产品必须使用电源来执行任务时，小心从事。

Preface

This manual contains maintenance procedures for service personnel. It is divided into the following chapters:

1. **General information** contains a general description of the printer and the maintenance approach used to repair it. Special tools and test equipment are, as well as general environmental and safety instructions.
 2. **Diagnostic information** contains an error indicator table, symptom tables, and service checks used to isolate failing field replaceable units (FRUs).
 3. **Diagnostic aids** contains tests and checks used to locate or repeat symptoms of printer problems.
 4. **Repair information** provides instructions for making printer adjustments and removing and installing FRUs.
 5. **Connector locations** uses illustrations to identify the connector locations and test points on the printer.
 6. **Preventive maintenance** contains the lubrication specifications and recommendations to prevent problems.
 7. **Parts catalog** contains illustrations and part numbers for individual FRUs.
- Appendix A** contains service tips and information.
Appendix B contains representative print samples.

Definitions

Note: A note provides additional information

Warning: A warning identifies something that might damage the product hardware or software.

CAUTION: A caution identifies something that might cause a servicer harm.



CAUTION: When you see this symbol, there is a danger from hazardous voltage in the area of the product where you are working. Unplug the product before you begin, or use caution if the product must receive power in order to perform the task.

1. General information

The Lexmark™ C750 is a network color printer that uses electrophotographic technology to deliver high quality images, presentation graphics, line art, and text. It prints up to 20 pages per minute (ppm) for both four-color and monochrome print jobs.

The printer's flexible design allows it to support a variety of printing needs. For example, if you need the printer to match the color process used in a particular application, you can select RGB or CMYK color corrections. You can also adjust the printed colors to more closely represent the colors on your computer display.

A variety of connectivity options enable the printer to be used in all types of system environments. You can attach one internal adapter to support network configurations requiring Ethernet, Token-Ring, LocalTalk, serial, infrared, or additional parallel ports.

The printer has flexible paper handling. It supports a wide variety of paper sizes, and has a standard multipurpose feeder that makes it easy to print on envelopes, transparencies, labels, card stock, and non-standard size paper. You can add up to three optional drawers to the base printer, which can increase the printer paper capacity to 2000 sheets.

The Lexmark C750 (5060-00x) laser printer is available in two models:

5060-001
5060-002

Tools required for service

Flat-blade screwdriver
#1 Phillips screwdriver, magnetic
#2 Phillips screwdriver, magnetic
#2 Phillips screwdriver, magnetic short-blade
T10 Torx screwdriver
Needlenose pliers
Diagonal pliers
Spring hook
Feeler gauges
Analog or digital multimeter
Parallel wrap plug 1319128
Serial wrap plug 1329048
Twinax/serial debug cable 1381963
Coax/serial debug cable 1381964
Flashlight or light source (recommended)

Options and features

Lexmark™ C750 printers support only Lexmark C750 paper-handling options. These options are not compatible with any other Lexmark printer.

- 500-Sheet Drawer - (includes 500-sheet tray and support unit) installs beneath the printer and holds approximately 500-sheets of 20 lb paper. Multiple optional drawers are supported simultaneously.
- 2,000-Sheet Drawer - installs beneath the printer and below any other optional input sources and holds approximately 2,000 sheets of 20 lb paper.
- 500-Sheet Tray - for environments with space or budget constraints this can be ordered for special media. This temporarily replaces the standard tray in a 500-sheet drawer and holds approximately 500-sheets of 20 lb paper.
- Duplex Option - offers two-side printing.
- Output Expander - installs above the printer's primary output bin to offer an additional output destination. This holds approximately 650 sheets of 20 lb paper. Only one output option above the printer is supported.
- 5-Bin Mailbox - installs above the printer's primary output bin to offer five output destinations in one part. Each of the five bins supports approximately 100 pages of 20 lb paper. Only one output option above the printer is supported.
- Finisher - offers stapling, hole punching, offset stacking and an additional output bin. Two models are available. Hole punching for 2-, 3- or 4-hole left-edge is available. The single staple position is the upper left corner. The finisher supports up to 3,000 sheets of non-stapled, non-punched media. For stapled media, the output bin supports up to 90 stapled sets or 2,700 sheets. The stapler staples a maximum of 30 sheets per set. Each printer supports one finisher.

High performance

- Up to 20 ppm black or color
- 350 MHz RISC processor
- 64MB RAM
- Time to first page
 - Black: less than 17.5 seconds
 - Color: less than 20 seconds

Print quality

True 1200 x 1200 dpi and 2400 image quality

Heavy volume reliability

- Up to 4,000-page average monthly duty cycle
- Up to 60,000-page maximum duty cycle based on a single month usage

Automatic calibration

The printer performs an automatic calibration under the following conditions.

- At power-on
- After 8 hours of power saver
- Approximately every 500 pages, at the end of a job
- After changing a print cartridge
- After changing an intermediate transfer unit

A manual calibration can be initiated by selecting Color Adjustment from the Utilities Menu.

Resolution

- 1200 x 1200 dpi
- 2400 image quality

Toner darkness

Toner darkness settings offer five user-selectable settings to balance print darkness and toner savings. The higher the setting, the darker the print. The toner darkness default setting is 4. Color level 4 and level 5 are the same.

The toner darkness setting is available through the operator panel under the Print Quality menu or through the Lexmark C750 PostScript emulation driver.

Printer specifications

Dimensions

Description	Width	Depth	Height	Weight
Printer				
Lexmark C750(n)	23.8 in. (604.5 mm)	18.5 in. (469.9 mm)	20.8 in. (528.3 mm)	105 lb (47.7 kg)
Lexmark C750dn (inc. Duplex Option)	23.8 in. (604.5 mm)	18.5 in. (469.9 mm)	24.3 in (617.2 mm)	118 lb (53.8 kg)
Options				
Duplex Option	23.8 in. (604.5 mm)	18.5 in. (469.9 mm)	3.5 in. (88.9 mm)	13.5 lb (6.1 kg)
2,000-Sheet Tray	26 in. (660.4 mm)	23.8 in. (604.5 mm)	15.4 in. (391.2 mm)	49 lb (22.3 kg)
Output Expander	14.5 in. (368.3 mm)	18.5 in. (469.9 mm)	7 in (177.8 mm)	4.5 lb (2 kg)
500-Sheet Drawer	23.8 in. (604.5 mm)	18.5 in. (469.9 mm)	5 in. (127 mm)	13.5 lb (6.1 kg)
500-Sheet Tray	17.3 in. (440 mm)	16.1 in. (410 mm)	4.3 in. (110 mm)	4.5 lb (2.0 kg)
5-Bin Mailbox	14.5 in. (368.3 mm)	18.5 in. (469.9 mm)	11.5 in. (292.1 mm)	8.2 lb (3.7 kg)
Finisher	33.5 in. (850.9 mm)	28.1 in. (713.7 mm)	35.1 in. (892 mm)	93.5 lb (42.5 kg)

Power and electrical specifications

Average nominal power requirements for the base printer configuration (110 volt). (Power levels are shown in watts.)

Printing states	Lexmark C750(n)	Lexmark C750dn
Printing - average power		
Base model	500	500
All options	540	540
Idle - average power		
Power Saver On	30	31
Power Saver Off	154	145
Printing - maximum current (110 V)	10.2	10.2

Note: Using a 220 to 110 power converter with the 110 volt printer is not recommended.

Electrical specifications

110 volt model

- 110 to 127 V ac at 47 to 63 hertz (hz) nominal
- 99 to 137 V ac, extreme

Operating clearances

Printer side	Model	Measurement
Left side	All	24 in. (609.6 mm)
Right side	All	15 in. (381 mm) ¹
Front	All	20 in. (508 mm)
Rear	All	12 in. (304.8 mm)
Top	C750(n)	42 in. (1,066.8 mm) ²
	C750dn	34 in. (863.6 mm) ²
¹ Allow 1,219.2 mm (48 in.) clearance to the right if you are adding a finisher. ² Allow clearance above the printer front door clearance and for adding options, such as additional input drawers, output expander or 5-bin mailbox.		

Fuser web oiler upgrade kit and replacements

The web oiler removes fuser roll contamination in machines which run a large number of vinyl or dual web labels. The web oiler works with all media types and enables the prolonged use of labels without sacrificing fuser life.

- **Web oiler life:** 100,000 pages
- **Availability:** Order the web oiler upgrade kit.

Upgrade kit

Description	Part number
115 V web oiler upgrade kit	12G6514
220 V web oiler upgrade kit	12G6515
100 V web oiler upgrade kit	12G6502
The installation of the web oiler upgrade kit converts a standard Lexmark C750 printer to an oil web capable printer. The web oiler upgrade kit includes an oiler fuser and web oiler.	

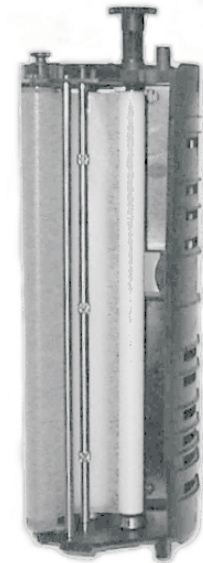

Replacements

Description	Part number
115 V web oiler fuser	12G6514
220 V web oiler fuser	12G6515
100 V web oiler fuser	12G6502
Web oiler replacement	12G6545

Acoustics

All measurements are made in accordance with ISO 7779 and conform with ISO 9296.

Model	Status	1-Meter average sound pressure
Lexmark C750(n)	2400 image quality printing	51 dBA
	Idle (standby)	42 dBA
Lexmark C750dn	2400 image quality printing	53 dBA
	Idle (standby)	42 dBA

Environment

Printer temperature and humidity

- Operating
 - Temperature: 60 to 90° F (15.6 to 32.3° C)
 - Relative humidity: 8 to 80%
 - Maximum wet bulb temperature: 73° F (22.8° C)
 - Altitude: 10,000 ft. (0 to 3,048 meters)
 - Atmospheric pressure: 74.6 kPa
- Power off
 - Temperature: 50 to 110° F (10 to 43.3° C)
 - Relative humidity: 8 to 80%
 - Maximum wet bulb temperature: 80.1° F (26.7° C)
 - Altitude: 10,000 ft. (0 to 3,048 meters)
 - Atmospheric pressure: 74.6 kPa
- Ambient operating environment*
 - Temperature: 60 to 90° F (15.6 to 32.2° C)
 - Relative humidity: 8 to 80%
- Storage and shipping (packaged printer) with or without print cartridge
 - Temperature: -40 to 110° F (-40 to 43.3° C)
- Print cartridge
 - Temperature: -40 to 110° F (-40 to 43.3° C)

In some cases, performance specifications (such as paper OCF, EP cartridge usage) are measured at an ambient condition.

Print speed and performance print speed

	2400 Image quality	1200 x 1200 dpi
Simplex printing on letter-size media (pages per minute)		
Letter—8.5 in. x 11 in.	20	10
A4—8.3 in. x 11.7 in.	19	9.5
Legal—8.5 in. x 14 in.	16.2	8.1
Transparencies	10	10
Envelopes	10	10
Duplex printing on letter-size media (sides per minute)		
Letter—8.5 in. x 11 in.	20	10
A4—8.3 in. x 11.7 in.	19	9.5
Legal—8.5 in. x 14 in.		16.2

Performance

Performance speed depends on:

- Interface to the host (USB, serial, parallel, network)
- Host system and application
- Page complexity and content
- Printer options installed or selected
- Available printer memory
- Media size and type
- Resolution
- Printer usage setting

Time to first print

Time to first print from standby mode:

- Black: <17.5 seconds
- Color: <20 seconds

Time to first print from power saver mode:

- Black: <180 seconds
- Color: <180 seconds

Note: All first copy times are measured for 2400 image quality, simplex printing on letter-size paper. The test job consists of the character "A" followed by a form feed (single-page job). The first copy time is defined as the elapsed time from hitting enter on the PC keyboard to the page exiting to the output bin. All tests will pick paper from the primary input tray and the page will exit into the primary output bin.

Processor

350 MHz

Duty cycle

- Up to 60K page maximum one-time usage
- Up to 4K pages per month average usage

Memory configuration

DRAM memory	Lexmark C750(n)	Lexmark C750dn
Standard	64MB	128MB
Maximum	512MB	512MB

Available memory options

Optional 64MB, 128MB and 256MB SDRAM DIMMs are available from Lexmark. The memory options are 168-pin synchronous DRAM DIMMs (dual in-line memory modules).

Flash memory options

- Memory slots for extra flash or DRAM: 2
- Expansion slots for optional interface cards: 1
- Code expansion slots (application solution firmware cards): 1
- On-board hard disk interface (for optional hard disk): 1

Additional memory may be required for printing complex pages or full-page, high-resolution images in 1200 image quality at rated speeds.

Media specifications

Media type

Media type	500-Sheet input	Multi-purpose tray	2,000-Sheet drawer	Duplex	Standard output	5-Bin Mailbox	Output Expander	Finisher to staple, hole punch, offset stack or with output bin
Paper	x	x	x	x	x	x	x	x
Card stock	x	x		x	x		x	
Transparencies	x	x			x		x	
Envelopes		x						
Vinyl labels	x	x			x		x	
Paper labels	x	x		x	x		x	
Polyester labels	x	x			x		x	
Dual web labels	x	x		x	x		x	
Integrated labels	x	x		x	x		x	

Media size

Media size supported	500-Sheet input	Multi-purpose tray	2,000-Sheet drawer	Duplex	Standard output	5-Bin Mailbox	Output Expander	Finisher to staple, hole punch, offset stack or with output bin
A4 8.27 in. x 11.7 in. (210 mm x 297 mm)	x	x	x	x	x	x	x	x ^{5, 6, 7}
A5 5.83 in. x 8.27 in. (148 mm x 210 mm)	x	x	x	x	x		x	x ⁵
JIS-B5 7.17 in. x 10.23 in. (182 mm x 257 mm)	x	x	x	x	x	x	x	x ⁵
Statement 5.5 in. x 8.5 in. (140 mm x 216 mm) ⁴	x	x		x	x		x	x ⁵
Letter 8.5 in. x 11 in. (216 mm x 279 mm)	x	x	x	x	x	x	x	x ^{5, 6, 7}
Folio 8.5 in. x 13 in. (216 mm x 330 mm) ⁴	x	x		x	x	x	x	x ^{5, 6, 7}
Legal 8.5 in. x 14 in. (216 mm x 256 mm)	x	x	x	x	x	x	x	x ^{5, 6, 7}
Executive 7.25 in. x 10.5 in. (184 mm x 267 mm)	x	x	x	x	x	x	x	x ^{6, 7}
Universal¹								
5.5 x 8.27 in. to 8.5 x 14 in. (139.7 x 210 mm to 215.9 x 355.6 mm)	x	x		x	x		x	
2.75 x 5 in. to 8.5 x 14 in. (69.85 x 127 mm to 229 x 355.6 mm)		x			x			
5.83 x 7.17 in. to 8.5 x 14 in. (148 x 182 mm to 215.9 x 355.6 mm)	x	x			x		x	
7 ¾ Envelope 3.875 in. x 7.5 in. (98 mm x 191 mm)		x			x		x	
9 Envelope 3.875 in. x 8.9 in. (98 mm x 225.4 mm)		x			x		x	
10 Envelope 4.125 in. x 9.5 in. (105 mm x 241 mm)		x			x		x	
DL envelope 4.33 in. x 8.66 in. (110 mm x 220 mm)		x			x		x	
C5 envelope 6.38 in. x 9.01 in. (162 mm x 229 mm)		x			x		x	
B5 envelope 6.93 in. x 9.84 in. (176 mm x 250 mm)		x			x		x	

Media size supported	500-Sheet input	Multi-purpose tray	2,000-Sheet drawer	Duplex	Standard output	5-Bin Mailbox	Output Expander	Finisher to staple, hole punch, offset stack or with output bin
Other envelope³								
3.87 x 6.38 in. to 6.93 x 9.84 in. (98.4 x 162 mm to 176 x 250 mm)		x			x		x	
<p>¹ When Universal is selected, the page is formatted for 8.5 x 14 in. (215.9 x 355.6 mm), unless the size is specified in the software application.</p> <p>² Narrow media should be loaded with the length in the feed direction (portrait).</p> <p>³ When Other Envelope is selected, the page is formatted for 8.5 x 14 in. (215.9 x 355.6 mm) unless the size is specified in the software application.</p> <p>⁴ Statement and Folio are supported as standard size through software only. Tray size sensing must be turned off before this standard size is visible in the paper-size menu on the operator panel.</p> <p>⁵ 2-hole punch is supported.</p> <p>⁶ 3-hole punch is supported.</p> <p>⁷ 4-hole punch is supported.</p>								

Input media types and weights

Media		Weight
Integrated trays ^f and optional 500-sheet drawer		
Paper ^{b, f}	Xerographic or business paper	16 to 19.9 lb bond (60 to 74.9 g/m ² grain long) 20 to 47 lb bond (75 to 176 g/m ² grain long)
Specialty papers	Gloss book	60 to 120 lb book (88 to 176 g/m ² grain long)
	Gloss cover	60 to 65 lb cover (162 to 176 g/m ² grain long)
Card stock - upper limit (grain long) ^{a, f}	Index	90 lb (163 g/m ²)
	Bristol Tag	100 lb (163 g/m ²)
	Cover	65 lb (176 g/m ²)
Card stock - upper limit (grain short) ^{a, f}	Index Bristol	110 lb (199 g/m ²)
	Tag	125 lb (203 g/m ²)
	Cover	80 lb (216 g/m ²)
Transparencies ^{i, j}	Laser printer type	43 to 45 lb bond (161 to 169 g/m ²)
Labels - upper limit	Paper	48 lb bond (180 g/m ²)
	Dual-web paper	48 lb bond (180 g/m ²)
	Polyester	59 lb bond (220 g/m ²)
	Vinyl ^{g, h}	92 lb liner (300 g/m ²)
Integrated forms	Pressure sensitive area ^c	(140 to 175 g/m ²)
	Paper base (grain long)	20 to 36 lb bond (75 to 135 g/m ²)
Multipurpose feeder		
Paper ^{b, f}	Xerographic or business paper	16 to 19.9 lb bond (60 to 74.9 g/m ² grain long) 20 to 47 lb bond (75 to 176 g/m ² grain long)
Specialty papers	Gloss book	60 to 120 lb book (88 to 176 g/m ² grain long)
	Gloss cover	60 to 65 lb cover (162 to 176 g/m ² grain long)
Card stock - upper limit (grain long) ^{a, f}	Index Bristol	90 lb (163 g/m ²)
	Tag	100 lb (163 g/m ²)
	Cover	65 lb (176 g/m ²)
Card stock - upper limit (grain short) ^{a, f}	Index Bristol	110 lb (199 g/m ²)
	Tag	125 lb (203 g/m ²)
	Cover	80 lb (216 g/m ²)
Transparencies ^{i, j}	Laser printer type	43 to 45 lb bond (161 to 169 g/m ²)
Labels - upper limit	Paper	53 lb bond (199 g/m ²)
	Dual-web paper	53 lb bond (199 g/m ²)
	Polyester	59 lb bond (220 g/m ²)
	Vinyl ^{g, h}	78 lb liner (260 g/m ²)
Integrated forms	Pressure sensitive area ^c	Up to 47 lb bond (140 to 175 g/m ²)
	Paper base (grain long)	20 to 36 lb bond (75 to 135 g/m ²)
Envelopes ^{d, e}	Sulfite, wood-free or up to 100% cotton bond	16 to 28 lb bond (60 to 105 g/m ²)

Media		Weight
2,000-Sheet drawer		
Paper ^{b, f}	Xerographic or business paper	16 to 19.9 lb bond (60 to 74.9 g/m ² grain long) 20 to 47 lb bond (75 to 176 g/m ² grain long)
Specialty papers	Gloss book	60 to 120 lb book (88 to 176 g/m ² grain long)
	Gloss cover	60 to 65 lb cover (162 to 176 g/m ² grain long)
<p>^a For 60 to 176 g/m² paper, grain long fibers are recommended. For papers heavier than 176 g/m², grain short is preferred.</p> <p>^b Paper less than 75 g/m² limited to less than 60% relative humidity and is not supported in duplex.</p> <p>^c Pressure-sensitive area must enter the printer first.</p> <p>^d 100% cotton content maximum weight is 24 lb bond. 28 lb envelopes are limited to 25% cotton content.</p> <p>^e 28 lb bond envelopes are limited to 25% cotton content.</p> <p>^f The duplex option supports the same types and weights as the printer except 16 to 19.9 lb (60 to 74.9 g/m² grain long paper, transparencies, labels, envelopes or A5 card stock.</p> <p>^g Vinyl labels are supported only when printing environment and media are 20 to 23° C (68 to 90°F).</p> <p>^h Refer to the Converter Listing on Lexmark's Home Page and Automated FAX system (LEXFAX™) for information on whether your vinyl label converter has passed Lexmark's criteria. Refer to the <i>Card Stock and Label Guide</i> for more details.</p> <p>ⁱ Lexmark transparency numbers 12A5940 and 12A5941 are supported from the standard tray, optional 500-sheet trays and the multipurpose feeder.</p> <p>^j Lexmark transparency numbers 12A5150 and 12A5151 are supported from the multipurpose feeder only.</p>		

Output media types and weights

Media		Weight
Standard output bin and optional Output Expander		
Paper ^{b, f}	Xerographic or business paper	16 to 19.9 lb bond (60 to 74.9 g/m ² grain long) 20 to 47 lb bond (75 to 176 g/m ² grain long)
Specialty papers	Gloss book	60 to 120 lb book (88 to 176 g/m ² grain long)
	Gloss cover	60 to 65 lb cover (162 to 176 g/m ² grain long)
Card stock - upper limit (grain long) ^a	Index Bristol	90 lb (163 g/m ²)
	Tag	100 lb (163 g/m ²)
	Cover	65 lb (176 g/m ²)
Card stock – upper limit (grain short) ^a	Index Bristol	110 lb (199 g/m ²)
	Tag	125 lb (203 g/m ²)
	Cover	80 lb (216 g/m ²)
Transparencies ^{i, j}	Laser printer type	43 to 45 lb bond (161 to 169 g/m ²)
Labels - upper limit	Paper	48 lb bond (180 g/m ²)
	Dual-web paper	48 lb bond (180 g/m ²)
	Polyester	59 lb bond (220 g/m ²)
	Vinyl G, H	92 lb liner (300 g/m ²)
Integrated forms	Pressure sensitive area ^c	Up to 47 lb bond (140 to 175 g/m ²)
	Paper base (grain long)	20 to 36 lb bond (75 to 135 g/m ²)
Envelopes ^{d, e}	Sulfite, wood-free or up to 100% cotton bond	16 to 28 lb bond (60 to 105 g/m ²)

Media		Weight
Finisher (Output Bin, Offset Stack)		
Paper ^{b, f}	Xerographic or business paper	16 to 19.9 lb bond (60 to 74.9 g/m ² grain long) 20 to 47 lb bond (75 to 176 g/m ² grain long)
Specialty papers	Gloss book	60 to 120 lb book (88 to 176 g/m ² grain long)
Finisher (Staple and Hole Punch)		
Paper	Xerographic or business paper	16 to 19.9 lb bond (60 to 74.9 g/m ² grain long) 20 to 32 lb bond (75 to 120.4 g/m ² grain long)
Specialty papers	Gloss book	60 to 84.5 lb book (88 to 125 g/m ² grain long)
5-Bin Mailbox		
Paper	Xerographic or business paper	16 to 19.9 lb bond (60 to 74.9 g/m ² grain long) 20 to 24 lb bond (75 to 90 g/m ² grain long)
<p>^a For 60 to 176 g/m² paper, grain long fibers are recommended. For papers heavier than 176 g/m², grain short is preferred.</p> <p>^b Paper less than 75 g/m² limited to less than 60% relative humidity and is not supported in duplex.</p> <p>^c Pressure-sensitive area must enter the printer first.</p> <p>^d 100% cotton content maximum weight is 24 lb bond. 28 lb envelopes are limited to 25% cotton content.</p> <p>^e 28 lb bond envelopes are limited to 25% cotton content.</p> <p>^f The duplex option supports the same types and weights as the printer except 16 to 19.9 lb (60 to 74.9 g/m² grain long paper, transparencies, labels, envelopes or A5 card stock.</p> <p>^g Vinyl labels are supported only when printing environment and media are 20 to 23° C (68 to 90°F).</p> <p>^h Refer to the Converter Listing on Lexmark's Home Page and Automated FAX system (<i>LEXFAX</i>) for information on whether your vinyl label converter has passed Lexmark's criteria. Refer to the Card Stock and Label Guide for more details.</p> <p>ⁱ Lexmark transparency numbers 12A5940 and 12A5941 are supported from the standard tray, optional 500-sheet trays and the multipurpose feeder.</p> <p>^j Lexmark transparency numbers 12A5150 and 12A5151 are supported from the multipurpose feeder only</p>		

Acronyms

BLDC	Brushless DC Motor
BOR	Black Only Retract
C	Cyan
CSU	Customer Setup
DIMM	Dual Inline Memory Module
DRAM	Dynamic Random Access Memory
EDO	Enhanced Data Out
EP	Electrophotographic Process
EPROM	Erasable Programmable Read-Only Memory
ESD	Electrostatic Discharge
FRU	Field Replaceable Unit
GB	Gigabyte
HCIT	High-Capacity Input Tray
HCOF	High-Capacity Output Finisher
HVPS	High Voltage Power Supply
ITU	Image Transfer Unit
K	Black
LASER	Light Amplification by Stimulated Emission of Radiation
LCD	Liquid Crystal Display
LED	Light-Emitting Diode
LVPS	Low Voltage Power Supply
M	Magenta
MPF	Multipurpose Feeder
MROM	Masked Read Only Memory
MS	Microswitch
NVRAM	Nonvolatile Random Access Memory
OEM	Original Equipment Manufacturer
OPT	Optical Sensor
PC	Photoconductor
pel	Picture element
POR	Power-On Reset
POST	Power-On Self Test
PSD	Position Sensing Device
PWM	Pulse Width Modulation
RIP	Raster Imaging Processor
ROM	Read Only Memory
SDRAM	Synchronous Dual Random Access Memory
SIMM	Single Inline Memory Module
SRAM	Static Random Access Memory
TMC	Toner Metering Cycle
UPR	Used Parts Return
V ac	Volts alternating current
V dc	Volts direct current
VTB	Vacuum Transport Belt
Y	Yellow

2. Diagnostic information

Start

CAUTION: Remove the power cord from the printer or electrical outlet before you connect or disconnect any cable or electronic board or assembly for personal safety and to prevent damage to the printer. Disconnect any connections between the printer and PCs/peripherals. The printer weighs 47.7 kg (105 lb) and requires at least two people to lift it safely. Make sure your fingers are not under the printer when you lift or set the printer down.

To determine the corrective action necessary to repair a printer, see the following topics:

- “POR (power-on reset) sequence” on page 2-2
- “Symptom table—base printer” on page 2-3
- “Symptom table—500-sheet drawer option” on page 2-4
- “Symptom table—HCIT 2000-sheet option” on page 2-4
- “Symptom table—output expander option” on page 2-5
- “Symptom table—5-bin mailbox option” on page 2-5
- “Symptom table—finisher option” on page 2-5
- “Error code table” on page 2-6
- “Sub error code table” on page 2-17
- “HCIT system board LED error code table” on page 2-128
- “HCOF error code table” on page 2-122
- “2xx Paper jam message table” on page 2-25
- “User attendance message table” on page 2-28
- “Service checks” on page 2-42

Note: There may be printer error messages that are not contained in this service manual. Call your next level support for assistance.

POR (power-on reset) sequence

The following is an example of the events that occur during the POR sequence for the base machine with no paper handling options installed.

1. Power the machine on.
2. +5V LED (Power ON) on the engine board comes on.
3. Operator Panel LED comes on solid.
4. All diamonds appear on the display.
5. While loading code, dots scroll across the display.
6. The following is an example of the screen that displays after the code is loaded.

96MB	350Mhz
96MB = Amount of Memory	350Mhz = Processor Speed

7. Performing Self Test is displayed.
8. Fuser drive motor turns on.
9. Main fan turns on.
10. RIP fan turns on.
11. Heartbeat LED on engine boards turns on.
12. Fuser lamps turn on.
13. Vacuum transport belt fan turns on.
14. ITU Missing is posted if the ITU is missing.
15. Fuser Missing is posted if the fuser is missing.
16. Close Door is posted if the front cover is open.
17. Busy is displayed
18. Front panel LED blinks.
19. Redrive exit roller turns.
20. Any cartridge errors are posted such as a defective cartridge, Lexmark Return Program information, or missing cartridge.
21. Any applicable maintenance messages display such as 80 Fuser Maintenance or 83 Maintenance.
22. One of the toner low messages appears when applicable: 88 yellow Toner Low, 88 Magenta Toner Low, 88 Cyan Toner Low, or 88 Black Toner Low.
23. Color calibration may be initiated. This is displayed if one of the following occurs:
 - The printer detects at power on, or the front cover is closed, that a new or different toner cartridge has been installed.
 - The printer detects at power on when the cover is closed that a new or different ITU has been installed.
 - The printer detects at power on that the fuser temperature is below 60° C.
 - When coming out of power saver if power saver has been active for 8 hours or longer.
 - If the printer is turned on when a calibration cycle was in progress since the printer was last powered off.
24. Ready is displayed.

Symptom tables

Symptom table—base printer

Symptom	Action
Fuser fan fails to run or is noisy	Go to “925 Error code” on page 2-90.
RIP fan fails to run or is noisy	Go to “927 Error code” on page 2-91.
VTB fan fails to run or is noisy	Go to “926 Error code” on page 2-90.
Machine inoperative: Fans don't turn, engine not on, lights not on, none of the printer functions work.	Go to “AC and DC power service check” on page 2-112.
Operator panel: One or more buttons do not work	Go to “Operator panel LCD/status LED/buttons service check” on page 2-132.
Operator panel: Display is blank, printer does not sound 5 <i>beeps</i> , but printer is not inoperative.	Replace the operator panel. Go to “Operator panel removal” on page 4-46.
Operator panel: Operator panel displays all diamonds continuously, sounds 5 <i>beeps</i> and POST inoperative	Go to “Operator panel LCD/status LED/buttons service check” on page 2-132.
Operator panel: One pel or random pels are missing	Replace the operator panel. Go to “Operator panel removal” on page 4-46.
Paper feed problems, base printer	Go to “200 Paper jam—Tray 1” on page 2-67.
Paper feed problems, integrated tray	Go to “Tray 1 service check” on page 2-149.
Paper feed problems, MPF	Go to “Multipurpose feeder (MPF)” on page 2-70.
Printer prints black only, no colors	Make sure that the printer is not set up to print black only. If the printer is set up correctly, check the black retract motor and gears for correct operation. If the gears are operating correctly, go to “Black only retract (BOR) service check” on page 2-117.
Print quality: 100% single color printed <ul style="list-style-type: none"> • All black print • All cyan print • All magenta print • All yellow print 	Go to “Entire page is mostly one color—Full bleed planes in one color” on page 2-140.
Print quality: blank page (no image)	Go to “Blank page (no image)” on page 2-139.
Print quality: evenly spaced horizontal marks or lines on the printed page	Go to “Horizontal lines or streaks” on page 2-137.
Print quality: black line	Black horizontal lines are most likely caused by a shorted charge roll in the print cartridge. Replace the black print cartridge.
Print quality: magenta, cyan, or yellow lines	Go to “Vertical lines or streaks” on page 2-138 or “Horizontal lines or streaks” on page 2-137.
Print quality: colored lines, streaks, or smudges	Go to “Vertical lines or streaks” on page 2-138 or “Horizontal lines or streaks” on page 2-137.
Print quality: light lines or streaks appear on the printed page	Go to “All colors have light print over the entire page” on page 2-142. or “One color has light print over the entire page” on page 2-143
Print quality: light print	Go to “Light print over the entire page” on page 2-142.
Print quality: missing colors	Go to “Missing colors—Complete or partially missing color planes” on page 2-141.
Print quality: uneven printing	Go to “Uneven printing” on page 2-145.
Print quality: poor color alignment	Go to “Poor color alignment” on page 2-144.

Symptom	Action
Print quality: toner on the back of the page	Go to “Toner is on the back of the printed page” on page 2-146.
Print quality: toner smears or rubs off the page	Go to “Toner smears or rubs off the page with no error code displayed” on page 2-145.
Print quality: multiple horizontal lines	Go to “Horizontal lines or streaks” on page 2-137.
Fuser problem: fuser cold	Go to “Cold fuser service” on page 2-127.
Fuser problem: fuser running too hot	Go to “Hot fuser service” on page 2-127.
Fuser problem: excessive fuser drive motor assembly noise	Go to “Excessive fuser drive motor assembly noise” on page 2-127.
Close Door displays constantly, unable to clear the message, POR incomplete	Go to “Close door/HVPS/printhead interlock switch service check” on page 2-118.

Symptom table—500-sheet drawer option

Symptom	Action
Printer fails to recognize the option is installed	Go to “The base printer does not recognize that tray x is installed.” on page 2-108.
The tray x autocompensator fails to retract, stays in down position	Go to “Tray x autocompensator fails to retract, stays in down position.” on page 2-109.
Paper Low message appears when adequate paper is installed (tray x)	Go to “The printer does not detect paper low in Tray x when adequate paper is installed in the tray.” on page 2-109.
Paper Out message appears when adequate paper is installed (tray x)	Go to “The printer does not detect paper out in tray x when adequate paper is installed in the tray.” on page 2-110.
Tray x does not detect size media is installed	Go to “Tray x does not detect size media is installed” on page 2-111.
Paper Jam 24x displayed. Media fails to feed from the 500-sheet option tray	Go to “500-sheet drawer option (242, 243, 244)” on page 2-77.

Symptom table—HCIT 2000-sheet option

Symptom	Action
Printer fails to recognize the option is installed	Go to “Printer does not recognize that the HCIT 2000-sheet option is installed.” on page 2-128.
HCIT does not function. There is no response. The HCIT is inoperative.	Go to “HCIT inoperative” on page 2-130.
HCIT does not recognize the correct paper size	Go to “HCIT 2000-sheet Option does not recognize the size paper selected.” on page 2-131.
Paper Jam 24x displayed. Media fails to feed from the 2000-sheet option.	Go to “2000-Sheet high-capacity input tray (HCIT) (243, 244)” on page 2-79.

Symptom table—output expander option

Symptom	Action
Printer fails to recognize the option is installed. The paper feeds into the standard bin.	Go to “Printer does not recognize that one or more output options as being installed.” on page 2-135
Printer does not display Output Bin Full	Go to “No indication that Bin x is full or no indication that Bin x is near full.” on page 2-135
Unable to clear Output Bin Full when no paper is in option.	Go to “Remove paper - Output Bin x displays, POST is incomplete, unable to clear the message.” on page 2-136
POST incomplete	Go to “Remove paper - Output Bin x displays, POST is incomplete, unable to clear the message.” on page 2-136
Paper Jam 271 displayed. Media jams at the output expander option.	Go to “271 Paper jam - Check Bin 1” on page 2-84.

Symptom table—5-bin mailbox option

Symptom	Action
Printer fails to recognize the option is installed. Paper feeds into the standard bin.	Go to “The printer does not recognize one or more output options as installed.” on page 2-105
Paper does not feed into the 5-Bin mailbox bin, as selected.	Go to “Paper does not feed into the 5-Bin mailbox bin selected. 271 Paper Jam - Check Bin 1 message” on page 2-106
Paper Jam 271 - Check Bin 1 message appears.	Go to “Paper does not feed into the 5-Bin mailbox bin selected. 271 Paper Jam - Check Bin 1 message” on page 2-106
Ready and Bin x Full message appears.	Go to “Ready Bin x Full message—may be able to clear message and paper feeds into bin selected.” on page 2-106
Bin is full, but no message appears.	Go to “Bin x Full—no message that Bin x is full” on page 2-107
Bin x Full displayed. You may be able to feed media into Bin x.	Go to “Ready - Bin x Full displays and paper feeds into bin x” on page 2-107
Paper jam 272 displayed. Media jams at the 5-bin mailbox.	Go to “272 Paper jam - Check Bin x” on page 2-85

Symptom table—finisher option

Check Finisher displayed, unable to clear message	Go to “Check Finisher displayed, unable to clear message” on page 2-123
Finisher is inoperative	Go to “Finisher is totally inoperative, no motor movement, no LEDs on” on page 2-123
Front door is open and no error message appears	Go to “Front door is open, no indication on display” on page 2-125
Inoperative fan	Go to “Fan in finisher inoperative” on page 2-125
Full chad box, no message appears	Go to “No indication that the chad box is full, no message” on page 2-126
Chad Box Full message appears when box is not full	Go to “Chad box full message when chad box is not full” on page 2-126

Error code table

Error code	Action
9xx service errors	
900 RIP Software	Go to “900 RIP Software Error” on page 2-88.
902 Service Engine Error 0	General Engine Software Errors 902 through 908 indicate an unrecoverable engine software error. The engine board may cause this type of error. Turn the printer off and on to try and clear the error code. If this does not fix the problem after several attempts, call your next level support before replacing the engine board.
904 Engine Software	Interface violation by RIP—check all cabling and connections to the RIP board. If no problem is found, replace the RIP board. See “RIP board removal” on page 4-70.
905 Engine Software	Interface violation by Paper Port Device—turn the printer off and on to try and clear the error code. If this does not fix the problem after several attempts, do the following: Check each paper handling option to isolate which one is causing the problem. If you do not find a problem with any of the options, replace the engine board. See “Engine board removal” on page 4-29.
906 Engine Software	Engine RAM Error—replace the engine board. See “Engine board removal” on page 4-29.
907 Engine Software	Engine Flash Error—the engine board might be causing the error code. Try the following: Reflash the engine board with the correct level code. If this does not fix the problem, replace the engine board. See “Engine board removal” on page 4-29.
910 Trans Sensor	Tray 1 Transparency Sensor Error—replace Tray 1 autocompensator assembly. See “Autocompensator pick assembly removal” on page 4-17. If this does not fix the problem, replace the engine board. See “Engine board removal” on page 4-29.
911 Trans Sensor	Tray 2 Transparency Sensor Error—replace Tray 2 transparency sensor assembly. If this does not fix the problem, replace the engine board. See “Engine board removal” on page 4-29.
912 Trans Sensor	Tray 3 Transparency Sensor Error—replace Tray 3 transparency sensor assembly. If this does not fix the problem, replace the engine board. See “Engine board removal” on page 4-29.
913 Trans Sensor	Tray 4 Transparency Sensor Error—replace Tray 4 transparency sensor assembly. If this does not fix the problem, replace the engine board. See “Engine board removal” on page 4-29.
914 Trans Sensor	Tray 1 Transparency Sensor Error—replace Tray 1 autocompensator assembly. See “Autocompensator pick assembly removal” on page 4-17. If this does not fix the problem, replace the engine board. See “Engine board removal” on page 4-29.
915 Trans Sensor	Tray 2 Transparency Sensor Error—replace Tray 2 transparency sensor assembly. If this does not fix the problem, replace the engine board. See “Engine board removal” on page 4-29.
916 Trans Sensor	Tray 3 Transparency Sensor Error—replace Tray 3 transparency sensor assembly. If this does not fix the problem, replace the engine board. See “Engine board removal” on page 4-29.

Error code	Action
917 Trans Sensor	Tray 4 Transparency Sensor Error—replace Tray 4 transparency sensor assembly. If this does not fix the problem, replace the engine board. See “Engine board removal” on page 4-29.
920 Color Calibrate	Unrecoverable TPS Gain Error—replace the ITU assembly. See “ITU assembly removal” on page 4-37.
921 Color Calibrate	Unrecoverable TPS Error—replace the ITU assembly. See “ITU assembly removal” on page 4-37.
922 Color Calibrate	Unrecoverable TPS Invalid Belt—replace the ITU assembly. See “ITU assembly removal” on page 4-37.
925 Fan Stalled	Fuser Fan—go to “925 Error code” on page 2-90.
926 Fan Stalled	VTB Fan—go to “926 Error code” on page 2-90.
927 Fan Stalled	RIP Fan—go to “927 Error code” on page 2-91.
930 LV Power Supply	Unable to find zero crossover point—Replace the LVPS. See “Low voltage power supply (LVPS) removal” on page 4-38.
931 LV Power Supply	Invalid AC Frequency—the AC power line frequency may be incorrect. Go to “AC power service check” on page 2-112.
939 RIP Engine Comm	The RIP card processor cannot communicate with the engine processor. Check the RIP to engine cable for correct installation. If installed correctly replace the RIP board. See “RIP board removal” on page 4-70. If this does not fix the problem, replace the engine board. See “Engine board removal” on page 4-29.
940 TMC Error - Cyan	Cyan toner metering cycle (TMC) switch failure—go to “940 Error code” on page 2-93.
941 TMC Error - Magenta	Magenta toner metering cycle (TMC) switch failure—go to “941 Error code” on page 2-95.
942 TMC Error - Yellow	Yellow toner metering cycle (TMC) switch failure—go to “942 Error code” on page 2-97.
943 TMC Error - Black	Black toner metering cycle (TMC) switch failure—go to “943 Error code” on page 2-99.
951 NVRAM Failure	NVRAM Chip Failure, engine board—replace the engine board. See “Engine board removal” on page 4-29.
952 NVRAM Failure	NVRAM CRC Failure, engine board—replace the engine board. See “Engine board removal” on page 4-29.
953 NVRAM Failure	NVRAM Chip Failure, RIP board—replace the RIP board. See “RIP board removal” on page 4-70.
954 NVRAM Failure	NVRAM CRC failure—replace the RIP board. See “RIP board removal” on page 4-70.
955 Code CRC <loc>	RIP board—this error indicates that the Code ROM or NAND failed the CRC check. The location of the failure is indicated by <loc>. Replace the RIP board. See “RIP board removal” on page 4-70.
956 System Board Processor Failure	Errors 956 and 957 indicate which area of the controller (RIP) card failed. Replace the RIP board. See “RIP board removal” on page 4-70.
957 System Board ASIC Failure	Replace the RIP board. See “RIP board removal” on page 4-70.
958 NAND Failure	Replace the RIP board. See “RIP board removal” on page 4-70.

Error code	Action
960 RAM Memory Error	RAM soldered on board is bad. Replace the RIP board. See “RIP board removal” on page 4-70.
961 RAM Memory Error	Errors 961 through 963 indicate that a memory error has occurred on RAM x in slot x installed on the RIP card. If available, switch memory from the failing slot with one from a non-failing slot to see if this fixes the problem. If it does not fix the problem, replace the RIP board. If another RAM option is not available, replace the RAM that is failing. If this does not fix the problem, replace the RIP board. See “RIP board removal” on page 4-70.
962 RAM Memory Error	
963 RAM Memory Error	
964 Emulation Error	Download Emulation CRC failure has occurred. The following actions may be taken: <ol style="list-style-type: none"> 1. Disable Download Emulation. 2. Program the download emulation into the code overlay SIMM, again. 3. If the problem is not resolved, replace the code overlay SIMM and download emulation, again.
975 Standard Network or Network Card x	Unrecognizable network errors 975 through 979 indicate a failure with the standard network port located on the RIP board or a network card in the specified slot x, x=1, 2 or 3. If unable to clear the error message, check the following: <ul style="list-style-type: none"> • If installed, check network card for correct installation. • If correctly installed, replace the network card. • If a network card is not installed, replace the RIP board.
976 Standard Network	Unrecoverable software or error in network port. Network card x. If unable to clear the error message, check the following: <ul style="list-style-type: none"> • If installed, check network card for correct installation. • If correctly installed, replace the network card. • If a network card is not installed, replace the RIP board.
978 Standard Network or Network Card x	Bad checksum while programming network card x port.
979 Standard Network or Network Card X	Flash parts failed while programming network card x port.
980 <device> comm	Engine is experiencing unreliable communications to the specified device.
981 <device> comm	Engine protocol violation detected by the specified device. <ul style="list-style-type: none"> • Engine • Duplex option • Tray x (where x=1,2,3,4, or 5) • Output bin (where x=1,2,3, or 6) <p>Note: This message is used for single bin output devices.</p> <ul style="list-style-type: none"> • Bin x to y (where x to y=1 to 5). <p>Note: This message is used for multiple bin output devices.</p>
982 <device> comm	Communications error detected by the specified device. <ul style="list-style-type: none"> • Engine • Duplex option • Tray x (where x=1,2,3,4, or 5) • Output bin (where x=1,2,3, or 6) <p>Note: This message is used for single bin output devices.</p> <ul style="list-style-type: none"> • Bin x to y (where x to y=1 to 5). <p>Note: This message is used for multiple bin output devices.</p>

Error code	Action
983 <device> comm	<p>Invalid command received by the specified device.</p> <ul style="list-style-type: none"> • Engine • Duplex option • Tray x (where x=1,2,3,4, or 5) • Output bin (where x=1,2,3, or 6) <p>Note: This message is used for single bin output devices.</p> <ul style="list-style-type: none"> • Bin x to y (where x to y=1 to 5). <p>Note: This message is used for multiple bin output devices.</p> <p>Check the autoconnects above and below the failing option to make sure they are seated and connected correctly. Go to service check for the device indicated.</p>
984 <device> comm	<p>Invalid command parameter received by the specified device.</p> <ul style="list-style-type: none"> • Engine • Duplex option • Tray x (where x=1,2,3,4, or 5) • Output bin x (where x=1,2,3, or 6) <p>Note: This message is used for single bin output devices.</p> <ul style="list-style-type: none"> • Bin x to y (where x to y=1 to 5). <p>Note: This message is used for multiple bin output devices.</p> <p>Check the autoconnects above and below the failing option to make sure they are seated and connected correctly. Go to service check for the device indicated.</p>
990 <device>	<p>This error message indicates that an equipment check condition has occurred in the specified device, but the device is unable to identify the exact component failure.</p> <p>Note: <device> can be one of the following:</p> <ul style="list-style-type: none"> • Duplex option • Tray x (where x=1,2,3,4, or 5) • Output bin x (where x=1,2,3, or 6) <p>Note: This message is used for single bin output devices.</p> <p>Output bin x to y (where x=1 to 5)</p> <p>Note: This message is used for multiple bin output devices.</p> <p>Go to the 990 service check for the specified device.</p>
991 <device> Card	<p>This error message indicates that a device has detected an equipment check in its system board.</p> <p>Note: <device> can be one of the following;</p> <ul style="list-style-type: none"> • Duplex option • Tray x (where x=1,2,3,4 or 5) • Output bin x (where x=1,2,3, or 6) <p>Note: This message is used for single bin output devices.</p> <ul style="list-style-type: none"> • Output bin x to y (where x=1 to 5) <p>Note: This message is used for multiple bin output devices. Go to the service check for the device indicated.</p> <p>Go to the service check for the specified device.</p>
1xx service errors	
100 ITU Error	ITU stall—go to “100 ITU Error” on page 2-42.
101 ITU Error	Invalid ITU memory—replace the ITU. See “ITU assembly removal” on page 4-37.
102 ITU Error	ITU shorted thermistor—replace the ITU. See “ITU assembly removal” on page 4-37.

Error code	Action
103 ITU Error	Memory load error—replace the ITU. See “ITU assembly removal” on page 4-37.
106 Printhead Error	<p>Cyan printhead lost Hsync</p> <p>Check for the correct installation of the all the cables to the RIP board assembly and to the printhead assembly; J5 and J6 on the RIP board. Go to “RIP board” on page 5-14. If the cables are connected correctly to the RIP board and to the printhead assembly, go to “Printhead diagnostics” on page 3-1.</p> <p>Note: Do not adjust or replace any printhead before performing the checks in “Printhead diagnostics” on page 3-1.</p>
107 Printhead Error	<p>Magenta printhead lost Hsync</p> <p>Check for the correct installation of the all the cables to the RIP board assembly and to the printhead assembly; J7 and J8 on the RIP board. Go to “RIP board” on page 5-14. If the cables are connected correctly to the RIP board and to the printhead assembly, go to “Printhead diagnostics” on page 3-1.</p> <p>Note: Do not adjust or replace any printhead before performing the checks in “Printhead diagnostics” on page 3-1.</p>
108 Printhead Error	<p>Yellow printhead lost Hsync</p> <p>Check for the correct installation of the all the cables to the RIP board assembly and to the printhead assembly; J2 and J3 on the RIP board. Go to “RIP board” on page 5-14. If the cables are connected correctly to the RIP board and to the printhead assembly, go to “Printhead diagnostics” on page 3-1.</p> <p>Note: Do not adjust or replace any printhead before performing the checks in “Printhead diagnostics” on page 3-1.</p>
109 Printhead Error	<p>Black printhead lost Hsync</p> <p>Check for the correct installation of the all the cables to the RIP board assembly and to the printhead assembly; J9, J10 and J11 on the RIP board. Go to “RIP board” on page 5-14. If the cables are connected correctly to the RIP board and to the printhead assembly, go to “Printhead diagnostics” on page 3-1.</p> <p>Note: Do not adjust or replace any printhead before performing the checks in “Printhead diagnostics” on page 3-1.</p>
110 Printhead Error	<p>No first Hsync (cyan)</p> <p>Check for the correct installation of the all the cables to the RIP board assembly and to the printhead assembly; J4, J5 and J6 on the RIP board. Go to “RIP board” on page 5-14. If the cables are connected correctly to the RIP board and to the printhead assembly, go to “Printhead diagnostics” on page 3-1.</p> <p>Note: Do not adjust or replace any printhead before performing the checks in “Printhead diagnostics” on page 3-1.</p>
111 Printhead Error	<p>No first Hsync (magenta)</p> <p>Check for the correct installation of the all the cables to the RIP board assembly and to the printhead assembly; J7, J8 and J9 on the RIP board. Go to “RIP board” on page 5-14. If the cables are connected correctly to the RIP board and to the printhead assembly, go to “Printhead diagnostics” on page 3-1.</p> <p>Note: Do not adjust or replace any printhead before performing the checks in “Printhead diagnostics” on page 3-1.</p>

Error code	Action
112 Printhead Error	<p>No first Hysnc (yellow)</p> <p>Check for the correct installation of the all the cables to the RIP board assembly and to the printhead assembly; J2, J3 and J4 on the RIP board. Go to “RIP board” on page 5-14. If the cables are connected correctly to the RIP board and to the printhead assembly, go to “Printhead diagnostics” on page 3-1.</p> <p>Note: Do not adjust or replace any printhead before performing the checks in “Printhead diagnostics” on page 3-1.</p>
113 Printhead Error	<p>No first Hysnc (black)</p> <p>Check for the correct installation of the all the cables to the RIP board assembly and to the printhead assembly; J2, J3 and J4 on the RIP board. Go to “RIP board” on page 5-14. If the cables are connected correctly to the RIP board and to the printhead assembly, go to “Printhead diagnostics” on page 3-1.</p> <p>Note: Do not adjust or replace any printhead before performing the checks in “Printhead diagnostics” on page 3-1.</p>
114 Printhead Error	<p>A black printhead servo error has been detected.</p> <p>Verify all packing material has been removed from the printer. Check at the top of the printhead for the cardboard or plastic packaging.</p> <div data-bbox="813 856 1352 1255" data-label="Image"> </div> <p>If error persists, see “Printhead diagnostics” on page 3-1.</p>
115 Printhead Error	<p>A cyan printhead servo error has been detected.</p> <p>Verify all packing material has been removed from the printer. Check at the top of the printhead for the cardboard or plastic packaging.</p> <div data-bbox="813 1434 1352 1833" data-label="Image"> </div> <p>If error persists, see “Printhead diagnostics” on page 3-1.</p>

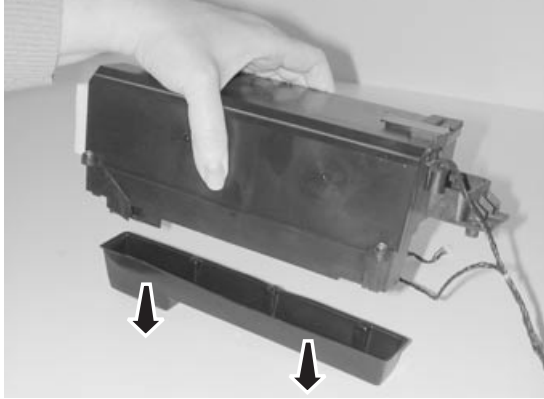
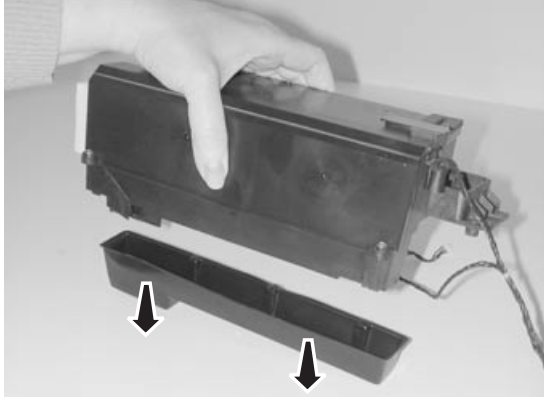
Error code	Action
116 Printhead Error	<p>A magenta printhead servo error has been detected.</p> <p>Verify all packing material has been removed from the printer. Check at the top of the printhead for the cardboard or plastic packaging.</p>  <p>If error persists, see “Printhead diagnostics” on page 3-1.</p>
117 Printhead Error	<p>A yellow printhead servo error has been detected.</p> <p>Verify all packing material has been removed from the printer. Check at the top of the printhead for the cardboard or plastic packaging.</p>  <p>If error persists, see “Printhead diagnostics” on page 3-1.</p>
120 Fuser Error	Wrong fuser lamp—hot roll. Replace with correct lamp. Go to “120 Error code” on page 2-44.
121 Fuser Error	Wrong fuser lamp—BUR. Replace with correct lamp. Go to “121 Error code” on page 2-45.
122 Fuser Error	Fuser below temperature when printing—hot roll. Go to “122 Error code” on page 2-46.
123 Fuser Error	Fuser below temperature when printing—BUR. Go to “123 Error code” on page 2-46.
124 Fuser Error	Fuser over temperature—hot roll. Go to “124 Error code” on page 2-46.
125 Fuser Error	Fuser over temperature—BUR. Go to “125 Error code” on page 2-47.
126 Fuser Error	Fuser open thermistor—hot roll. Go to “126 Error code” on page 2-47.
127 Fuser Error	Fuser open thermistor—BUR. Go to “127 Error code” on page 2-48.

Error code	Action
128 Fuser Error	Fuser under temperature in standby—hot roll. Go to “128 Error code” on page 2-48.
129 Fuser Error	Fuser under temperature in standby—BUR. Go to “129 Error code” on page 2-49.
130 Fuser Error	Fuser failed to reach standby temperature—hot roll. Go to “130 Error code” on page 2-50.
131 Fuser Error	Fuser failed to reach standby temperature—BUR. Go to “131 Error code” on page 2-51.
132 Fuser Error	Fuser cold hot roll. Go to “132 Error code” on page 2-52.
133 Fuser Error	Fuser cold roll—BUR. Go to “133 Error code” on page 2-53.
134 Fuser Error	Fuser lamp on too long—hot roll. Go to “134 Error code” on page 2-54.
135 Fuser Error	Fuser lamp on too long—BUR. Go to “135 Error code” on page 2-55.
136 Fuser Error	Fuser cam position not found—go to “136 Error code” on page 2-56.
140 Motor	DC motor accel stall—registration. Replace the registration motor assembly. See “Registration motor” on page 4-64. If this does not fix the problem, replace the engine board. See “Engine board removal” on page 4-29.
141 Motor	DC pick motor excessive PWM—registration motor—replace the registration motor. See “Registration motor removal” on page 4-69. If this does not fix the problem, replace the engine board. See “Engine board removal” on page 4-29.
142 Motor	DC pick motor, over speed—registration motor—replace the registration motor assembly. See “Registration motor removal” on page 4-69. If this does not fix the problem, replace the engine board. See “Engine board removal” on page 4-29.
143 Motor	DC pick motor, no encoder feedback—registration motor—replace the registration motor assembly. See “Registration motor removal” on page 4-69. If this does not fix the problem, replace the engine board. See “Engine board removal” on page 4-29.
144 Motor	DC motor accel stall—autocompensator motor—replace the autocompensator assembly. See “Autocompensator pick assembly removal” on page 4-17. If this does not fix the problem, replace the engine board. See “Engine board removal” on page 4-29.
145 Motor	DC motor excessive PWM—autocompensator motor—replace the autocompensator assembly. See “Autocompensator pick assembly removal” on page 4-17. If this does not fix the problem, replace the engine board. See “Engine board removal” on page 4-29.
146 Motor	DC motor over speed—autocompensator motor—replace the autocompensator assembly. See “Autocompensator pick assembly removal” on page 4-17. If this does not fix the problem, replace the engine board. See “Engine board removal” on page 4-29.

Error code	Action
147 Motor	DC motor pick motor, no encoder feedback—autocompensator motor—replace the autocompensator assembly. See “Autocompensator pick assembly removal” on page 4-17. If this does not fix the problem, replace the engine board See “Engine board removal” on page 4-29.
148 Motor	ITU belt motor, unable to lock—go to “148 Error code” on page 2-57.
149 Motor	Fuser drive motor unable to lock—go to “149 Error code” on page 2-58.
150 Motor	Black cartridge motor unable to lock—go to “150 Error code” on page 2-58.
151 Motor	Magenta cartridge motor unable to lock—go to “151 Error code” on page 2-59.
152 Motor	Cyan cartridge motor unable to lock—go to “152 Error code” on page 2-59.
153 Motor	Yellow cartridge motor unable to lock. Go to “153 Error code” on page 2-60.
154 Motor	ITU belt motor—lost lock. Go to “154 Error code” on page 2-61.
155 Motor	Fuser drive motor—lost lock. Go to “155 Error code” on page 2-62.
156 Motor	Black cartridge motor lost lock. Go to “156 Error code” on page 2-62.
157 Motor	Magenta cartridge motor lost lock. Go to “157 Error code” on page 2-63.
158 Motor	Cyan cartridge motor lost lock. Go to “158 Error code” on page 2-64.
159 Motor	Yellow cartridge motor lost lock. Go to “159 Error code” on page 2-64.
160 Motor	ITU belt BLDC motor mfg. unknown. Go to “160 Error code” on page 2-65.
161 Motor	Fuser drive BLDC motor mfg. unknown. Go to “161 Error code” on page 2-65.
162 Motor	Black cartridge BLDC motor mfg. unknown. Go to “162 Error code” on page 2-65.
163 Motor	Magenta cartridge BLDC motor mfg. unknown. Go to “163 Error code” on page 2-66.
164 Motor	Cyan cartridge BLDC motor mfg. unknown. Go to “164 Error code” on page 2-66.
165 Motor	Yellow cartridge BLDC motor mfg. unknown. Go to “165 Error code” on page 2-66.
167 Motor	Web oiler encoder error, incorrect configuration ID. See “Web oiler fuser kit installation” on page 4-85.
168 Motor	Unknown manufacture type—perform “Motor Detect” on page 3-16. If you do not find the problem after performing the test, call your next level support.
169 Motor	Mirror motor lock not achieved (black). Go to “Printhead diagnostics” on page 3-1. Note: Do not adjust or replace any printhead before performing checks in “Printhead diagnostics” on page 3-1.

Error code	Action
170 Motor	Mirror motor lost lock (black). Go to “Printhead diagnostics” on page 3-1. Note: Do not adjust or replace any printhead before performing checks in “Printhead diagnostics” on page 3-1.
171 Motor	Mirror motor lock not achieved (cyan). Go to “Printhead diagnostics” on page 3-1. Note: Do not adjust or replace any printhead before performing checks in “Printhead diagnostics” on page 3-1.
172 Motor	Mirror motor lost lock (cyan). Go to “Printhead diagnostics” on page 3-1. Note: Do not adjust or replace any printhead before performing checks in “Printhead diagnostics” on page 3-1.
173 Motor	Mirror motor lock not achieved (magenta). Go to “Printhead diagnostics” on page 3-1. Note: Do not adjust or replace any printhead before performing checks in “Printhead diagnostics” on page 3-1.
174 Motor	Mirror motor lost lock (magenta). Go to “Printhead diagnostics” on page 3-1. Note: Do not adjust or replace any printhead before performing checks in “Printhead diagnostics” on page 3-1.
175 Motor	Mirror motor lock not achieved (yellow). Go to “Printhead diagnostics” on page 3-1. Note: Do not adjust or replace any printhead before performing checks in “Printhead diagnostics” on page 3-1.
176 Motor	Mirror motor lost lock (yellow). Go to “Printhead diagnostics” on page 3-1. Note: Do not adjust or replace any printhead before performing checks in “Printhead diagnostics” on page 3-1.
180 PSD Error	PSD sensor error (black). Update machine code. Run a Line Length test page. See “Prt Line Len Pg” on page 3-19. If the problem persists, go to “Printhead diagnostics” on page 3-1.
181 PSD Error	PSD sensor error (cyan). Update machine code. Run a Line Length test page. See “Prt Line Len Pg” on page 3-19. If the problem persists, go to “Printhead diagnostics” on page 3-1.
182 PSD Error	PSD sensor error (magenta). Update machine code. Run a Line Length test page. See “Prt Line Len Pg” on page 3-19. If the problem persists, go to “Printhead diagnostics” on page 3-1.
183 PSD Error	PSD sensor error (yellow). Update machine code. Run a Line Length test page. See “Prt Line Len Pg” on page 3-19. If the problem persists, go to “Printhead diagnostics” on page 3-1.
184 PSD Error	EOS sensor out of range scan direction (black). Update the machine code. Run a Line Length test page. See “Prt Line Len Pg” on page 3-19. If the problem persists, go to “Printhead diagnostics” on page 3-1.
185 PSD Error	EOS sensor out of range scan direction (cyan). Update the machine code. Run a Line Length test page. See “Prt Line Len Pg” on page 3-19. If the problem persists, go to “Printhead diagnostics” on page 3-1.

Error code	Action
186 PSD Error	EOS sensor out of range scan direction (magenta). Update the machine code. Run a Line Length test page. See “Prt Line Len Pg” on page 3-19. If the problem persists, go to “Printhead diagnostics” on page 3-1.
187 PSD Error	EOS sensor out of range scan direction (yellow). Update the machine code. Run a Line Length test page. See “Prt Line Len Pg” on page 3-19. If the problem persists, go to “Printhead diagnostics” on page 3-1.
188 PSD Error	EOS sensor out of range process direction (black). Update the machine code. Run a Line Length test page. See “Prt Line Len Pg” on page 3-19. If the problem persists, go to “Printhead diagnostics” on page 3-1.
189 PSD Error	EOS sensor out of range process direction (cyan). Update the machine code. Run a Line Length test page. See “Prt Line Len Pg” on page 3-19. If the problem persists, go to “Printhead diagnostics” on page 3-1.
190 PSD Error	EOS sensor out of range process direction (magenta). Update the machine code. Run a Line Length test page. See “Prt Line Len Pg” on page 3-19. If the problem persists, go to “Printhead diagnostics” on page 3-1.
191 PSD Error	EOS sensor out of range process direction (yellow). Update the machine code. Run a Line Length test page. See “Prt Line Len Pg” on page 3-19. If the problem persists, go to “Printhead diagnostics” on page 3-1.
192 PSD Error	No EOS reading (black). Update the machine code. Run a Line Length test page. See “Prt Line Len Pg” on page 3-19. If the problem persists, go to “Printhead diagnostics” on page 3-1.
193 PSD Error	No EOS reading (cyan). Update the machine code. Run a Line Length test page. See “Prt Line Len Pg” on page 3-19. If the problem persists, go to “Printhead diagnostics” on page 3-1.
194 PSD Error	No EOS reading (magenta). Update the machine code. Run a Line Length test page. See “Prt Line Len Pg” on page 3-19. If the problem persists, go to “Printhead diagnostics” on page 3-1.
195 PSD Error	No EOS reading (yellow). Update the machine code. Run a Line Length test page. See “Prt Line Len Pg” on page 3-19. If the problem persists, go to “Printhead diagnostics” on page 3-1.
196 Service Thermal System	The printer has detected an error in the printhead thermal drift compensation system. Perform the test for “Drift Sensors” on page 3-16.
199 Service Reflash RIP	This message indicates that the printer has detected an invalid version of the RIP code and must be reflashed to the approved version. Contact your next level support.

Sub error code table

Use this table to troubleshoot the printer when 9xx and 1xx error codes are displayed.

When a 9xx or 1xx error code is displayed, press and hold **Return** and press **Select** to view the Sub error code.

Sub error code	Explanation
2D 00	No media available in duplex option.
2D 01	Leading edge of image position has reached image halt location.
2D 02	Paper jam detected. Sensor S2 was activated at an unexpected time.
2D 03	Paper jam detected. Sensor S2 was not activated within the timeout period.
2D 04	Paper jam detected. Sensor S2 did not deactivate during the timeout period.
2D 05	Paper jam detected. Sensor NM was activated at an unexpected time.
2D 06	Paper jam detected. Sensor NM did not deactivate during the timeout period.
2D 07	Paper jam detected. The fuser exit sensor was activated at an unexpected time.
2D 08	Paper jam detected. The fuser exit sensor did not deactivate by the previous page or the current page did not activate the fuser exit sensor within the timeout period.
2D 09	Paper jam detected. The fuser exit sensor did not deactivate during the timeout period.
2D 0A	Paper jam detected. A paper jam detected in the Duplex Option.
2D 0B	Paper jam detected. A paper jam detected in Tray 2.
2D 0C	Paper jam detected. A paper jam detected in Tray 3.
2D 0D	Paper jam detected. A paper jam detected in Tray 4.
2D 0E	S2 sensor was not made within timeout period (source is MPF).
2D 0F	S2 sensor was made too early.
2D 10	S2 sensor was made too early (source is MPF).
2D 11	Media versus registration error is out of acceptable bounds.
2D 12	Media versus registration error is out of acceptable bounds (source is MPF).
2D 13	Prism sensor detected incorrect media (source is MPF).
2D 14	Prism sensor detected different media from the tray sensor.
2D 15	Paper jam detected. A paper jam detected in Stacker 1.
2D 16	Paper jam detected. A paper jam detected in Stacker 2.
2D 17	Paper jam detected. A paper jam detected in Stacker 3.
2D 18	Paper jam detected. A paper jam detected in Stacker 4.
2D 19	Paper jam detected. A paper jam detected in Stacker 5.
2D 1A	Paper jam detected. A paper jam detected in Stacker 6.
2D 1B	Sensor (S2) has been activated or obstructed.
2D 1C	Fuser narrow media sensor obstructed.

Sub error code	Explanation
2D 1D	Fuser exit sensor obstructed.
2D 1E	Duplex sensor(s) obstructed.
2D 1F	Tray 2 sensor obstructed.
2D 20	Tray 3 sensor obstructed.
2D 21	Tray 4 sensor obstructed.
2D 22	Pass thru sensor in Stacker 1 obstructed.
2D 23	Pass thru sensor in Stacker 2 obstructed.
2D 24	Pass thru sensor in Stacker 3 obstructed.
2D 25	Pass thru sensor in Stacker 4 obstructed.
2D 26	Pass thru sensor in Stacker 5 obstructed.
2D 27	Pass thru sensor in Stacker 6 obstructed.
2D 28	Paper jam detected. A paper jam detected in the Duplex option.
2D 29	Paper jam detected. A paper jam detected in Tray 2.
2D 2A	Paper jam detected. A paper jam detected in Tray 3.
2D 2B	Paper jam detected. A paper jam detected in Tray 4.
2D 2C	Duplex input motor error detected, the engine detected a stall condition.
2D 2D	Duplex input motor error detected, the engine detected a PWM error.
2D 2E	Duplex input motor error detected, the engine detected a motor encoder error.
2D 2F	Duplex reversing motor error detected, the engine detected a stall condition.
2D 30	Duplex reversing motor error detected, the engine has detected a PWM error condition.
2D 31	Duplex reversing motor error detected, the engine detected a motor encoder error.
2D 32	Tray 2 pick motor stall error detected.
2D 33	Tray 2 pick motor PWM error detected.
2D 34	Tray 2 pick motor encoder error detected.
2D 35	Tray 2 feed motor stall error detected.
2D 36	Tray 2 feed motor PWM error detected.
2D 37	Tray 2 feed motor Encoder error detected.
2D 38	Tray 3 pick motor stall error detected.
2D 39	Tray 3 pick motor PWM error detected.
2D 3A	Tray 3 pick motor Encoder error detected.
2D 3B	Tray 4 feed motor stall error detected.
2D 3C	Tray 4 feed motor PWM error detected.
2D 3D	Tray 4 feed motor Encoder error detected.

Sub error code	Explanation
2D 3E	Tray 4 pick motor stall error detected.
2D 3F	Tray 4 pick motor PWM error detected.
2D 40	Tray 4 pick motor Encoder error detected.
2D 41	Tray 4 feed motor stall error detected.
2D 42	Tray 4 feed motor PWM error detected.
2D 43	Tray 4 feed motor encoder error detected.
2D 44	Registration Motor stall error detected when picking media from the MPF.
2D 45	Autocompensator motor stall error detected when picking media from the MPF.
2D 46	Autocompensator motor stall error detected when picking media from Tray 1.
2D 47	Registration motor PWM error detected.
2D 48	Autocompensator motor PWM error detected when picking media from the MPF.
2D 49	Autocompensator motor PWM error detected when picking media from Tray 1.
2D 4A	Registration Motor Encoder error detected.
2D 4B	Autocompensator motor encoder error detected when picking media from the MPF.
2D 4C	Autocompensator motor encoder error detected when picking media from Tray 1.
2D 4E	Output expander sensor was not activated by the media.
2D 4F	Topmost output option sensor obstructed.
2D 50	5-Bin mailbox pass thru sensor was not deactivated by the previous page or not activated by the current page.
2D 51	5-Bin mailbox pass thru sensor was not activated by the media.
2D 52	5-Bin mailbox sensor was not deactivated by the previous page or not activated by the current page.
2D 53	5-Bin mailbox sensor was not activated by the media.
2D 54	Expander did not declare page complete.
2D 55	5-Bin mailbox did not declare page complete.
2D 56	5-Bin mailbox S1 broke early.
2D 57	5-Bin mailbox S2 broke early.
2D 58	Output expander sensor broke early.
2D 59	Detected early break of fuser exit sensor.
2D 5A	Finisher detected staple jam.

Programming errors - P101 through P116

These error codes may be displayed whenever a new code upgrade has been attempted. It is possible that the wrong type of code, network versus non-network, or a corrupted file was probably sent to the printer. Verify that the correct type of code is being flashed to the printer.

The following displays whenever a programming error occurs while programming the RIP code.

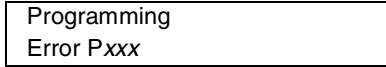

Error code	Description
P105	Invalid package - A network file was used to program a non-network printer, or a non-network file was used to program a network printer.
P109	Package size error - An update file was used to program the printer, but the package did not fit within the space allocated in the Master Boot Record.
P112	Invalid DLE - An upddle.fls file was used to update the DLE code on printer with a firmware card installed, but the DLE was not found on the firmware card.
P200	No firmware card - A DLE file was sent to the printer, but no firmware is installed.

Understanding the printer operator panel

The operator panel has five buttons, a display, and a light that flashes when the printer is processing a job indicated by the Busy message.

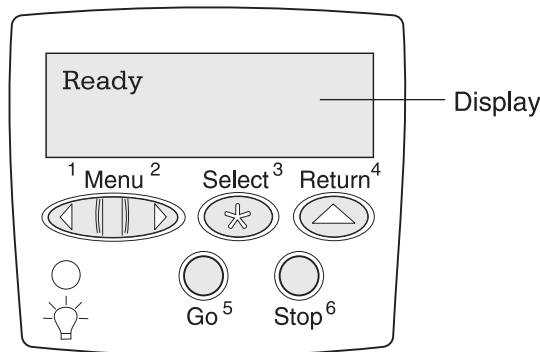

Operator panel buttons

Button	Function
Go	<p>Press Go to:</p> <ul style="list-style-type: none"> Return to the Ready state if the printer is offline (the Ready message does not appear on the display). Exit printer menus and return to the Ready state. Clear some operator panel messages. Resume printing after loading paper or clearing paper jams. Exit Power Saver. <p>If you have changed printer settings from the operator panel menus, press Go before sending a job to print. The printer must display Ready for jobs to print.</p>

Button	Function
Menu	<p>Press Menu to:</p> <ul style="list-style-type: none"> Take the printer offline (out of the Ready state) and enter the menus. When the printer is offline, press Menu to scroll through the menus and menu items. List the menu items in the Job Menu (during Busy state). <p>For menu items that have numerical values, such as Copies, press and hold Menu to scroll through the list of values. Release the button when the number you want appears.</p> <p>If you see a <code>Menus Disabled</code> message, you will not be able to change default settings. You can still clear messages and select items from the Job Menu when printing. When you send a job to print, change printer properties to select the settings you want for your job.</p>
Select	<p>Press Select to:</p> <ul style="list-style-type: none"> Open the menu shown on the second line of the display. Save the displayed menu item as the new user default setting. Clear certain messages from the display. Continue printing after the <code>Change <x></code> message appears.
Return	Press Return to go back to the previous menu level or menu item.
Stop	<p>Press Stop at the <code>Ready</code>, <code>Busy</code>, or <code>Waiting</code> message to temporarily take the printer offline. The message changes to <code>Not Ready</code>. No data is lost.</p> <p>Press Go to return the printer to the <code>Ready</code>, <code>Busy</code>, or <code>Waiting</code> state.</p>
1, 2, 3, 4, 5, 6	Use the numbers located next to the names of the buttons to enter your personal identification number (PIN) after you send a confidential job.

<p>Finishing Menu</p> <ul style="list-style-type: none"> Duplex Duplex Bind Copies Blank Pages Collation Separator Sheets Separator Source Hole Punch Offset Pages Staple Job Staple Prime Src Multipage Print Multipage Order Multipage View Multipage Border 	<p>Job Menu</p> <ul style="list-style-type: none"> Cancel Job Reset Printer Print Buffer Cancel Fax Confidential Job Held Jobs Reset Active Bin 	<p>Paper Menu</p> <ul style="list-style-type: none"> Paper Source Paper Size Paper Type Custom Types Output Bin Configure Bins Overflow Bin Assign Type/Bin Substitute Size Configure MP Paper Texture Paper Weight Paper Loading Universal Setup 	<p>PCL Emul Menu</p> <ul style="list-style-type: none"> Font Source Font Name Point Size Pitch Symbol Set Orientation Lines per Page A4 Width Auto CR after LF Auto LF after CR Tray Renumber 	<p>Serial Menu</p> <ul style="list-style-type: none"> PCL SmartSwitch PS SmartSwitch NPA Mode Serial Buffer Job Buffering RS-232/RS-422 RS-422 Polarity Serial Protocol Robust XON Baud Data Bits Parity Honor DSR 	<p>Supplies Menu</p> <ul style="list-style-type: none"> <color> Toner Oiler Waste Bottle
<p>Network Menu</p> <ul style="list-style-type: none"> PCL SmartSwitch PS SmartSwitch MAC Binary PS NPA Mode Network Buffer Job Buffering Network <x> Setup Std Net Setup 	<p>LocalTalk Menu</p> <ul style="list-style-type: none"> LocalTalk Port PCL SmartSwitch PS SmartSwitch NPA Mode LocalTalk Buffer Job Buffering NPA Hosts LocalTalk Name LocalTalk Addr LocalTalk Zone 	<p>Parallel Menu</p> <ul style="list-style-type: none"> PCL SmartSwitch PS SmartSwitch NPA Mode Parallel Buffer Job Buffering Advanced Status Protocol Honor Init Parallel Mode 1 Parallel Mode 2 MAC Binary PS 	<p>Setup Menu</p> <ul style="list-style-type: none"> Printer Language Printer Usage Power Saver Resource Save Download Target Print Timeout Auto Continue Wait Timeout Jam Recovery Page Protect Display Language Alarm Control Hole Punch Alarm Staple Alarm Toner Alarm Job Accounting Job Acct Limit Print Area 	<p>PostScript Menu</p> <ul style="list-style-type: none"> Print PS Error Font Priority Image Smoothing 	<p>USB Menu</p> <ul style="list-style-type: none"> PCL SmartSwitch PS SmartSwitch MAC Binary PS NPA Mode USB Buffer Job Buffering
	<p>Infrared Menu</p> <ul style="list-style-type: none"> Infrared Port PCL SmartSwitch PS SmartSwitch NPA Mode Infrared Buffer Job Buffering Window Size Transmit Delay Max Baud Rate 			<p>Color Menu</p> <ul style="list-style-type: none"> Color Correction Manual Color Print Mode Print Resolution Toner Darkness 	<p>Utilities Menu</p> <ul style="list-style-type: none"> Color Adjust Color Samples Print Demo Print Menus Print Net <x> Setup Print Fonts Print Directory Factory Defaults Format Flash Defragment Flash Format Disk Job Acct Stat Hex Trace

Color Menu

Menu Item	Purpose	Values	
Color Correction	To adjust the printed color to better match the colors of other output devices or standard color systems. Note: Due to the differences between additive and subtractive colors, certain colors that appear on your monitor are impossible to duplicate on your printer.	Auto*	Applies different color correction to each object on the printed page depending upon the type of object and how the color for each object is specified.
		Vivid	Applies a color correction algorithm that produces brighter, more saturated colors.
		Off	No color correction is implemented.
		CMYK	Applies color correction to approximate SWOP color output.
		Display	Applies color correction to approximate the colors on a computer display.
Manual Color	To let users customize color correction output from the operator panel.	RGB Image	Vivid: Applies a color correction algorithm that produces brighter, more saturated colors. May be selected for all incoming color formats. sRGB Display*: Applies color correction to produce output that approximates the colors displayed on a computer monitor. sRGB Vivid: Increases color saturation for the sRGB Display color correction. Off: No color correction is implemented.
		RGB Text	Vivid, sRGB Display, sRGB Vivid*, Off
		RGB Graphics	Vivid, sRGB Display, sRGB Vivid*, Off
		CMYK Image	US CMYK: Applies color correction to approximate SWOP color output. Euro CMYK*: Applies color correction to approximate EuroScale color output. Vivid: Applies a color correction algorithm that produces brighter, more saturated colors. May be selected for all incoming color formats. Vivid CMYK: Increases color saturation for the US CMYK color correction. Off: No color correction is implemented.
		CMYK Graphics	US CMYK, Euro CMYK*, Vivid, Vivid CMYK, Off
Print Mode	To determine whether images are printed in a monochrome grayscale or in color. Note: Selections made in the Lexmark C750 PostScript emulation or PCL drivers for Windows will override other selections.	Color*	
		Black & White	

Menu Item	Purpose	Values	
Print Resolution	To define the number of dots printed per inch (dpi). The higher the value, the sharper the clarity of printed characters and graphics.	2400 IQ*	Provides the highest resolution for detailed line art or images.
		1200 dpi	Provides high quality output for text and business graphics, such as line art and electronically generated charts. This setting also provides increased gloss.
Toner Darkness	To lighten or darken text images, or conserve toner.	1–5 (4*)	<p>1 is lightest; 5 is darkest.</p> <p>Select a lower value for finer line width, higher definition in graphics, and lighter grayscale images. Select a higher value for bolder line widths or darker grayscale images. Select 5 for very bold text. Select a value less than 4 to conserve toner.</p> <p>A vertical bar () indicates the factory default value. An arrow symbol (>) indicates a user default value.</p>

Utilities Menu

Menu Item	Purpose	Values	
Color Adjust	To manually relinearize the color tables, adjusting for variations in output that occur as a result of environmental conditions.		
Color Samples	To assist in selecting colors used by certain applications.		
Defragment Flash	To retrieve storage area lost when resources are deleted from flash memory. Warning: Do not turn off the printer while the flash is defragmenting.	Yes	Printer transfers all resources stored in flash memory to printer memory and then reformats the flash memory option. When the format operation is complete, the resources are loaded back into flash memory.
		No	Printer cancels the request to defragment the flash memory.
Factory Defaults	To return your printer settings to the factory default values.	Restore	<ul style="list-style-type: none"> All menu items are returned to the factory default values except: <ul style="list-style-type: none"> Display Language. All settings in the Parallel Menu, Serial Menu, Network Menu, Infrared Menu, LocalTalk Menu, and USB Menu. All downloaded resources (fonts, macros, and symbol sets) in printer memory (RAM) are deleted. (Resources residing in flash memory or on the hard disk are unaffected.)
		Do Not Restore	User-defined settings remain.

Menu Item	Purpose	Values	
Format Disk	To format the printer hard disk. Warning: Do not turn off the printer while the hard disk is formatting.	Yes	Deletes any data stored on the hard disk and prepares the device to receive new resources.
		No	Cancels the request to format the hard disk and leaves current resources stored on the disk.
Format Flash	To format the flash memory. Warning: Do not turn off the printer while the flash is formatting.	Yes	Deletes any data stored in flash memory and prepares the flash memory to receive new resources.
		No	Cancels the request to format the flash memory and leaves current resources stored in flash memory.
Hex Trace	To help isolate the source of a print job problem. With Hex Trace selected, all data sent to the printer is printed in hexadecimal and character representation. Control codes are not executed. To exit Hex Trace, turn the printer off or reset the printer from the Job Menu.		
Job Acct Stat	To print a listing of all job statistics stored on the hard disk, or to clear all statistics on the disk.	Print	Prints all statistics available for the most recent print jobs.
		Clear	Deletes all accumulated job statistics from the hard disk.
Print Demo	To view a list of the demo files available in printer memory, in flash memory, and on optional hard disk.		
Print Directory	To print a list of all the resources stored in flash memory or on the hard disk. Print Directory is available only when either a nondefective flash or disk is installed and formatted, and Job Buffer Size is not set to 100%.		
Print Fonts	To print a sample of all the fonts available for the selected printer language.	PCL Fonts	Prints a sample of all printer fonts available for PCL emulation.
		PS Fonts	Prints a sample of all printer fonts available for PostScript emulation.
Print Menus	To print a listing of the current user default values, the installed options, the amount of installed printer memory, and the status of printer supplies.		
Print Net <x> Setup	To print information relating to the internal print server and the network settings defined by the Network <x> Setup menu item in the Network Menu.		

2xx Paper jam message table

Note: A secondary message only displays if the finisher option is installed. Use the “**Sub error code table**” on **page 2-17** to help diagnose paper jam problems.

2xx code	Primary message	Secondary message	Description
200	Paper Jam Clear Paper Path (Jam location information)	Leave sheets in Finisher area 5	<p>Primary: Paper is jammed at the printer input sensor. Open the printer left door to access the paper jam. If sheets have been accumulated to be stapled or offset when the jam occurred, the printer alternately flashes the primary and secondary messages to indicate that all accumulated sheets not be removed during the jam clearing procedure. If the problem persists, go to “200 Paper jam—Tray 1” on page 2-67.</p> <p>Secondary: When this message is displayed, do not remove accumulated sheets during the jam clearing procedure as the printer will not reprint the removed sheets. Also, if the accumulated sheets are removed, the portion of the job printed after the jam will not be stapled.</p>
201	Paper Jam Clear Paper Path (Jam location information)	Leave sheets in Finisher area 5	<p>Primary: Paper is jammed at the fuser. Open the right door to access the jam area. If sheets have been accumulated to be stapled or offset when the jam occurred, the printer alternately flashes the primary and secondary messages to indicate that all accumulated sheets not be removed during the jam clearing procedure. If the problem persists, go to “201 Paper jam” on page 2-71.</p> <p>Secondary: When this message is displayed, do not remove accumulated sheets during the jam clearing procedure as the printer will not reprint the removed sheets. Also, if the accumulated sheets are removed, the portion of the job printed after the jam will not be stapled.</p>
202	Paper Jam Clear Paper Path (Jam location information)	Leave sheets in Finisher area 5	<p>Primary: A paper jam has occurred at the fuser. Open the right door to access the jam area. If sheets have been accumulated to be stapled or offset when the jam is detected, the printer alternately flashes the primary and secondary messages to indicate that all accumulated sheets should not be removed during the jam clearing procedure. If the problem persists, go to “202 Paper jam” on page 2-73.</p> <p>Secondary: When this message is displayed, do not remove accumulated sheets during the jam clearing procedure. The printer will not reprint the removed sheets. Also, if the accumulated sheets are removed, the portion of the job printed after the jam will not be stapled.</p>

2xx code	Primary message	Secondary message	Description
203	Paper Jam Clear paper Path	Leave job in Finisher	<p>Primary: The media is jammed due to a transparency sensor mismatch. Open the printer left door to access the jammed media. If sheets have been accumulated to be stapled or offset when the jam is detected, the printer alternately flashes the primary and secondary messages to indicate that all accumulated sheets should not be removed during the jam clearing procedure.</p> <p>Secondary: When this message is displayed, do not remove accumulated sheets during the jam clearing procedure. The printer will not reprint the removed sheets. Also, if the accumulated sheets are removed, the portion of the job printed after the jam will not be stapled.</p>
230	Paper Jam Clear Paper Path	Leave Job in Finisher	<p>Primary: The media is most likely jammed in the duplex option, remove the duplex tray to access the jam area. If sheets have been accumulated to be stapled or offset when the jam occurred, the printer alternately flashes the primary and secondary messages to indicate that all accumulated sheets not be removed during the jam clearing procedure. If the problem persists, go to “230 Paper jam” on page 2-76.</p> <p>Secondary: When this message is displayed, do not remove accumulated sheets during the jam clearing procedure as the printer will not reprint the removed sheets. Also, if the accumulated sheets are removed, the portion of the job printed after the jam will not be stapled.</p>
24x	Paper Jam Clear Paper Path	Leave Job in Finisher	<p>Primary: Media is jammed around Tray x (Tray x=2 through 4) and applies to both a 500 Tray and HCIT tray. Try opening Tray x. If the tray is difficult to remove then you may need to remove the tray above or below Tray x to remove the jam. If sheets have been accumulated to be stapled or offset when the jam occurred, the printer alternately flashes the primary and secondary messages to indicate that all accumulated sheets not be removed during the jam clearing procedure. If the problem persists, go to “24x Paper jam” on page 2-77.</p> <p>Secondary: When this message is displayed, do not remove accumulated sheets during the jam clearing procedure as the printer will not reprint the removed sheets. Also, if the accumulated sheets are removed, the portion of the job printed after the jam will not be stapled.</p>
250	Paper Jam Clear Paper Path	Leave Job in Finisher	<p>Primary: Media is jammed in the MP Feeder. If sheets have been accumulated to be stapled or offset when the jam occurred, the printer alternately flashes the primary and secondary messages to indicate that all accumulated sheets not be removed during the jam clearing procedure. If the problem persists, go to “250 Paper jam” on page 2-82.</p> <p>Secondary: When this message is displayed, do not remove accumulated sheets during the jam clearing procedure as the printer will not reprint the removed sheets. Also, if the accumulated sheets are removed, the portion of the job printed after the jam will not be stapled.</p>

2xx code	Primary message	Secondary message	Description
251	Paper Jam Clear Paper Path Go to “Autocompensator service check” on page 2-114	Leave Job in Finisher	<p>Primary: Media is jammed in the paper path near the MP Feeder due to an in-line transparency sensor mismatch. If sheets have been accumulated to be stapled or offset when the jam is detected, the printer alternately flashes the primary and secondary messages to indicate that all accumulated sheets should not be removed during the jam clearing procedure.</p> <p>Secondary: Do not remove accumulated sheets during the jam clearing procedure. The printer will not reprint the removed sheets. Also, if the accumulated sheets are removed, the portion of the job printed after the jam will not be stapled.</p>
271	Paper Jam Clear Paper Path	Leave Job in Finisher	<p>Primary: Media is jammed at output Bin 1. Open the rear door of Bin 1 to access the jam. If sheets have been accumulated to be stapled or offset when the jam occurred, the printer alternately flashes the primary and secondary messages to indicate that all accumulated sheets not be removed during the jam clearing procedure.</p> <p>Secondary: When this message is displayed, do not remove accumulated sheets during the jam clearing procedure as the printer will not reprint the removed sheets. Also, if the accumulated sheets are removed, the portion of the job printed after the jam will not be stapled.</p>
272	Paper Jam Clear Paper Path	Leave Job in Finisher	<p>Primary: Media is jammed in output bin x. Open the door of output bin x to access the jam. If sheets have been accumulated to be stapled or offset when the jam occurred, the printer alternately flashes the primary and secondary messages to indicate that all accumulated sheets not be removed during the jam clearing procedure.</p> <p>Secondary: When this message is displayed, do not remove accumulated sheets during the jam clearing procedure as the printer will not reprint the removed sheets. Also, if the accumulated sheets are removed, the portion of the job printed after the jam will not be stapled.</p>
280	Paper Jam Clear Paper Path	Leave Job in Finisher	<p>Primary: Paper is jammed in the finisher option, open the side door or top cover to access the jam. If sheets have been accumulated to be stapled or offset when the jam occurred, the printer alternately flashes the primary and secondary messages to indicate that all accumulated sheets not be removed during the jam clearing procedure.</p> <p>Secondary: When this message is displayed, do not remove accumulated sheets during the jam clearing procedure as the printer will not reprint the removed sheets. Also, if the accumulated sheets are removed, the portion of the job printed after the jam will not be stapled.</p>

User attendance message table

User primary message	User secondary message	Explanation
200 Paper Jam Clear Paper Path	Leave sheets in Finisher area 5	<p>Primary: This message indicates that a paper jam has occurred at or near the printer input sensor. Open the printer's left door (paper jam removal door) to access the jammed media.</p> <p>Secondary: If sheets have been accumulated to be stapled when the jam is detected, the printer alternately flashes the primary and secondary messages indicating the accumulated sheets should not be removed during jam clearing.</p> <p>Note: When the secondary message is displayed, if the accumulated sheets are removed the printer will not reprint these sheets. Also if the print job is completed, the portion of the job printed after the jam will not be stapled.</p>
201 Paper Jam Clear Paper Path	Leave sheets in Finisher area 5	<p>Primary: Media has jammed before the fuser. Open the printer left door to access the jammed media.</p> <p>Secondary: If sheets have been accumulated to be stapled when the jam is detected, the printer alternately flashes the primary and secondary messages indicating the accumulated sheets should not be removed during jam clearing.</p> <p>Note: When the secondary message is displayed, if the accumulated sheets are removed the printer will not reprint these sheets. Also if the print job is completed, the portion of the job printed after the jam will not be stapled.</p>
202 Paper Jam Clear Paper Path	Leave sheets in Finisher area 5	<p>Primary: Media has jammed at the fuser. Open the printer right door to access the jam area.</p> <p>Secondary: If sheets have been accumulated to be stapled when the jam is detected, the printer alternately flashes the primary and secondary messages indicating the accumulated sheets should not be removed during jam clearing.</p> <p>Note: When the secondary message is displayed, if the accumulated sheets are removed the printer will not reprint these sheets. Also if the print job is completed, the portion of the job printed after the jam will not be stapled.</p>
203 Paper Jam Clear Paper Path	Leave Job in Finisher area 5	<p>Primary: Media has jammed due to a transparency sensor mismatch. Open the printer left door to access the jammed media.</p> <p>Secondary: If sheets have been accumulated to be stapled when the jam is detected, the printer alternately flashes the primary and secondary messages indicating the accumulated sheets should not be removed during jam clearing.</p> <p>Note: When the secondary message is displayed, if the accumulated sheets are removed the printer will not reprint these sheets. Also if the print job is completed, the portion of the job printed after the jam will not be stapled.</p>

User primary message	User secondary message	Explanation
230 Paper Jam Clear Paper Path	Leave Job in Finisher area 5	<p>Primary: Paper has most likely jammed in the duplex option. Remove the duplex tray to access the jam.</p> <p>Secondary: If sheets have been accumulated to be stapled when the jam is detected, the printer alternately flashes the primary and secondary messages indicating the accumulated sheets should not be removed during jam clearing.</p> <p>Note: When the secondary message is displayed, if the accumulated sheets are removed the printer will not reprint these sheets. Also if the print job is completed, the portion of the job printed after the jam will not be stapled.</p>
24x Paper Jam Clear Paper Path	Leave Job in Finisher area 5	<p>Primary: This paper jam message can apply to both the 500-sheet option tray and HCIT option. Tray x ($x=2$ through 4). Try opening tray x, if the tray is difficult to remove then you may need to remove the tray above or below tray x to remove the jammed media.</p> <p>Secondary: If sheets have been accumulated to be stapled when the jam is detected, the printer alternately flashes the primary and secondary messages indicating the accumulated sheets should not be removed during jam clearing.</p> <p>Note: When the secondary message is displayed, if the accumulated sheets are removed the printer will not reprint these sheets. Also if the print job is completed, the portion of the job printed after the jam will not be stapled.</p>
250 Paper Jam Clear Paper Path	Leave Job in Finisher area 5	<p>Primary: Paper is jammed in the MPF.</p> <p>Secondary: If sheets have been accumulated to be stapled when the jam is detected, the printer alternately flashes the primary and secondary messages indicating the accumulated sheets should not be removed during jam clearing.</p> <p>Note: When the secondary message is displayed, if the accumulated sheets are removed the printer will not reprint these sheets. Also if the print job is completed, the portion of the job printed after the jam will not be stapled.</p>
251 Paper Jam Clear Paper Path	Leave Job in Finisher area 5	<p>Primary: The paper has jammed in the paper path near the MPF due to an in-line transparency sensor mismatch.</p> <p>Secondary: If sheets have been accumulated to be stapled when the jam is detected, the printer alternately flashes the primary and secondary messages indicating the accumulated sheets should not be removed during jam clearing.</p> <p>Note: When the secondary message is displayed, if the accumulated sheets are removed the printer will not reprint these sheets. Also if the print job is completed, the portion of the job printed after the jam will not be stapled.</p>
271 Paper Jam Clear Paper Path	Leave Job in Finisher area 5	<p>Primary: Paper has jammed at output bin 1. Open the door of bin 1 to access the jammed media.</p> <p>Secondary: If sheets have been accumulated to be stapled when the jam is detected, the printer alternately flashes the primary and secondary messages indicating the accumulated sheets should not be removed during jam clearing.</p> <p>Note: When the secondary message is displayed, if the accumulated sheets are removed the printer will not reprint these sheets. Also if the print job is completed, the portion of the job printed after the jam will not be stapled.</p>

User primary message	User secondary message	Explanation
272 Paper Jam Clear Paper Path	Leave Job in Finisher area 5	<p>Primary: Media is jammed in the 5-bin mailbox option. Open the rear door of option to access the jammed media.</p> <p>Secondary: If sheets have been accumulated to be stapled when the jam is detected, the printer alternately flashes the primary and secondary messages indicating the accumulated sheets should not be removed during jam clearing.</p> <p>Note: When the secondary message is displayed, if the accumulated sheets are removed the printer will not reprint these sheets. Also if the print job is completed, the portion of the job printed after the jam will not be stapled.</p>
280 Paper Jam Clear Paper Path	Leave sheets in Finisher area 5	<p>Primary: Media has jammed in the finisher option. Open the finisher side door to top cover to access the jammed pages.</p> <p>Secondary: If sheets have been accumulated to be stapled when the jam is detected, the printer alternately flashes the primary and secondary messages indicating the accumulated sheets should not be removed during jam clearing.</p> <p>Note: When the secondary message is displayed, if the accumulated sheets are removed the printer will not reprint these sheets. Also if the print job is completed, the portion of the job printed after the jam will not be stapled.</p>
282 Staple Jam Check Stapler 283 Staple Jam Check Stapler	Remove Job from Finisher	<p>These messages are displayed when the stapler device detects a paper jam.</p> <p>282 Staple Jam indicates that a staple jam has been detected during normal stapler operation such as when printing and stapling jobs.</p> <p>283 Staple Jam indicates that a staple jam has been detected during a priming operation. No secondary message will be displayed.</p> <p>Note: After the error has been cleared, the printer does not reprint any pages which existed in the accumulator for stapling.</p> <p>The following actions can be taken while either the primary or secondary messages are displayed: Press Go to initiate priming and resume printing.</p> <p>Note: Use of the “Sub error code table” on page 2-17 may help in diagnosing 282 and 283 Errors.</p>
Setup Required		<p>This message is displayed when the printer has detected at POST, that packing material is still installed and must be removed. The user should verify that the machine is properly setup.</p> <p>Press Go and Reflash Code.</p>
A Alignment =x.x*		<p>This message is displayed when an ITU Alignment Procedure is in process and the printer is prompting the user for the x (x=A through L) alignment value. Alignment values for A through L (=x.x*) -7 to +7 in 0.5 increments.</p> <ul style="list-style-type: none"> • Enter the alignment value and press Select to continue to the next alignment value. • To abort the alignment operation press Go or Return.

User primary message	User secondary message	Explanation
Calibrate <Tray x> Load Paper		<p>This message is displayed when the user has initiated a tray calibration procedure. <Tray x> = tray 1 through 4, MPF, envelope feeder, manual paper, and manual envelope.</p> <p>The following actions can be taken:</p> <ul style="list-style-type: none"> • Load paper into tray x and press Go to initiate the calibration. • Press Menu to access the Busy/Waiting menu. <p>The following functions are available using the Busy/Waiting menu:</p> <ul style="list-style-type: none"> • Reset Printer • Reset Active Bin • Check Supply Levels
Tray x Not Calibrated		<p>This message is displayed when a tray has been detected that is uncalibrated. It usually means a user-correctable NVRAM problem or the tray was not calibrated at the factory or needs to be calibrated.</p> <p>Perform the following steps to calibrate a tray:</p> <ol style="list-style-type: none"> 1. Turn the printer off. 2. Press and hold the Select and Return buttons while powering on the printer. 3. Release the buttons when Performing Self Test displays. 4. Select Calibrate Trays. 5. Select Tray x from the menu. 6. The display prompts load paper if necessary. 7. Load paper. 8. Press Go. <p>Calibrating Tray x is displayed</p> <ol style="list-style-type: none"> 9. Repeat for any other trays that might need to be calibrated. 10. Exit Configuration Menu.
Change Cartridge <Color> Invalid Refill		<p>This message is displayed when the printer has detected a refilled Lexmark Return Program cartridge. <Color> can be black, cyan, magenta, or yellow.</p> <p>Remove the toner cartridge and install a new cartridge.</p> <p>Note: The user receives this message for every invalid cartridge installed.</p>
Change <custom Type Name> <input source>		<p>This message is displayed when the printer is requesting the operator to change the media installed in one of the input sources. <input source>=Tray 1 through 5, MPF or Envelope Feeder.</p>
Change <input source> <Custom String> Change <input source> <Size> Change <input source> <type> <size>		<p>One of the following is displayed on line two.</p> <p>The user can define a name for each of the custom types (Custom 1 through 6)</p>

User primary message	User secondary message	Explanation
Reattach Output Bin x Reattach Bins x-y Check Tray x Connection		<p>These messages are displayed anytime the printer loses communications with one of the following options:</p> <ul style="list-style-type: none"> • Output Bin x (x=1, 2, or 3) • Bins (x-y=1 through 5) • Tray x (x=2, 3, 4, or 5) • Duplex • Finisher
Check Duplex Connection Check Finisher Connection		<p>The specified option could have been removed from the printer, maybe to clear a paper jam or to uninstall the option or the option may be still installed but experiencing a communications problem. The option may not be fully installed or it may have a hardware failure. The most likely cause of this message is a failure to reattach the option when removed to service a printer intervention.</p> <p>If the option was temporarily removed or not connected properly, then reattach or reconnect it. When the option is recognized, the printer automatically clears the attendance message and continues. Press Go to execute a configuration change which will tell the printer the option has been Hot Unplugged removed. In this case it is assumed that the user wants to continue to operate the printer with the option removed. If the problem continues, turn the printer off and back on. If the message continues to be displayed, turn the printer off, remove the option and call for service.</p>
Close Door		<p>This message is displayed when the printer upper front cover (door) is open.</p> <p>Close the upper front cover (door).</p>
Close Finisher Door		<p>This message is displayed when the finisher Option top cover is open. Close the finisher top cover.</p>
Disk Corrupted		<p>This message is displayed when the printer has detected that there are errors on the hard disk that could not be corrected. The disk cannot be used until it has been reformatted.</p> <p>The following actions can be taken:</p> <ul style="list-style-type: none"> • Press Return or Stop to clear the message. The disk cannot be used without reformatting the disk. <p>Note: All data will be lost for the following action:</p> <ul style="list-style-type: none"> • Press Go to format the disk.
Hole Punch Waste Full		<p>This message is displayed when the Hole Punch Alarm is on and the code has determined that the hole punch waste box is full.</p> <p>The following actions may be taken while this message is displayed:</p> <ul style="list-style-type: none"> • The user may empty the hole punch box and put it back to clear the message. • Press Go to ignore the message and the job prints without hole punching. <p>Each time a new job requests hole punch and the box is not emptied, this message is displayed.</p>

User primary message	User secondary message	Explanation
Priming Failed, Retry. GO/Stop		<p>This message is displayed when an error has occurred during the printer staple priming operation.</p> <p>The following actions can be taken:</p> <ul style="list-style-type: none"> • Press Go to initiate the priming operation again or • Press Return or Stop to cancel the priming operation. <p>Note: If no action is taken and the printer Auto Continue setting is not disabled, the printer eventually clears the message, the priming operation is cancelled, and the printer resumes printing.</p>
Insert Staple Cartridge		<p>This message is displayed when the staple cartridge is missing or installed incorrectly. This message can be displayed at any of the following times, regardless of the Staple Alarm setting.</p> <ul style="list-style-type: none"> • At POST • After the stapler door has been closed. <p>The following actions can be taken:</p> <ul style="list-style-type: none"> • Install the staple cartridge or • Press Go to ignore this message. <p>The printer now handles staple jobs as if the staple unit were installed with no staples. The Staples Empty warning appears on the status line and Load Staples may immediately appear.</p>
Load Staples		<p>This message is displayed when the Staples Empty Alarm is activated and there are no staples in the staple unit or the staple unit is not installed.</p> <p>This message appears:</p> <ul style="list-style-type: none"> • Prior to printing the first page of a batch of pages that are to be stapled or • During the printing of a batch of pages that are to be stapled (if the condition cannot be detected prior to printing the first page of the batch). <p>The following actions can be taken:</p> <ul style="list-style-type: none"> • A new staple cartridge may be installed to clear this message and start/continue printing the staple batch or • Ignore the Load Staples request for this print job by pressing Go or Select. The printer resumes printing, however the print job for which stapling was selected is not stapled or • Press Menu> or Menu< to access the Busy/Waiting Menu. <p>The following functions are available using the Busy/Waiting Menu:</p> <ul style="list-style-type: none"> • Cancel Job • Reset Printer • Reset Active Bin • Check Supply Levels <p>Note: Menu Lockout does not prevent access to the Busy/Waiting Menu.</p>

User primary message	User secondary message	Explanation
Install Tray x or Cancel Job Install Bin x or Cancel Job Install Duplex or Cancel Job		<p>This message is displayed when the printer requests the user to insert tray x before it can continue printing the job. The printer needs to pick media from the missing tray or the trays below it.</p> <p>Tray=Tray 1, Tray 2, Tray 3, Tray 4, or Tray 5.</p> <p>Note: This message displays when refilling the trays during a job. Before filling tray x take the printer offline by pressing Stop and wait for pages to reach the output bin.</p> <p>The following actions can be taken:</p> <ul style="list-style-type: none"> • Insert the requested tray or • Press Menu> or Menu< to access the Busy/Waiting Menu. <p>The following functions are available using the Busy/Waiting Menu:</p> <ul style="list-style-type: none"> • Cancel Job • Reset Printer • Reset Active Bin • Check Supply Levels <p>This message is displayed when the user has Hot Unplugged a paper handling option and the printer requires the reinstallation of the option to print a page which has been formatted by an install Tray x interpreter prior to removal of the option or Cancel Job:</p> <ul style="list-style-type: none"> • Bin x (x=1,2 or 3) • Tray x (x=2,3,4 or 5) • Duplex <p>The following actions can be taken:</p> <ul style="list-style-type: none"> • Insert the requested option or • Press Menu> or Menu< to access the Busy/Waiting Menu Group. <p>The following functions are available using the Busy/Waiting Menu:</p> <ul style="list-style-type: none"> • Cancel Job • Reset Printer • Reset Active Bin • Check Supply Levels
No DRAM Installed		<p>This message is displayed when the printer is turned on and no DRAM is installed.</p> <p>Turn the printer off, install DRAM, and turn the printer back on.</p>
30 ITU Missing		<p>This message is displayed when the ITU is missing.</p> <p>Turn the printer off, insert the ITU, and turn the printer back on.</p>
30 Yellow Toner Cart Missing 30 Magenta Toner Cart Missing 30 Cyan Toner Cart Missing 30 Black Toner Cart Missing		<p>This message is displayed when the printer is missing the yellow, magenta, cyan, or black toner cartridge. Open the front cover, insert the toner cartridge, and close the cover.</p>

User primary message	User secondary message	Explanation
31 Defective Black Cartridge 31 Defective Yellow Cartridge 31 Defective Magenta Cartridge 31 Defective Cyan Cartridge		This message is displayed when the top cover is closed and a defective print cartridge is detected. It may take the printer 10 to 20 seconds to determine whether or not the print cartridge is installed. The printer may print pages during this 10 to 20 second interval. If pages are allowed to print, then they will not be reprinted once a valid print cartridge is inserted. Replace the defective print cartridge.
32 Unsupported		This message is displayed when the front cover is closed with the wrong print cartridge installed.
33 Calibration Error Cyan 33 Calibration Error Magenta 33 Calibration Error Yellow 33 Calibration Error Black		This message is displayed when the printer detects a calibration error for a particular color.
34 Incorrect Media <type> <size> Change MP Feeder		This message displayed when the printer detects a media mismatch feeding from the MPF. Primary Message: Incorrect media detected Secondary Message: <type>= Bond, Cardstock, Colored, Labels, Envelopes, Letterhead, Plain, Preprinted, Transparency, or Glossy. <size>= Letter, Legal, B5, A4, Exec, Univ, A5, A3, 11x17, Folio, Stmt, 73/4, 9, 10, DL, C5, B5, or other. The following actions can be taken: <ul style="list-style-type: none"> • Replace the media in the MPF with the requested media and press Go or • Press Menu> or Menu< to access the Busy/Waiting Menu. The following functions are available using the Busy/Waiting Menu: <ul style="list-style-type: none"> • Cancel Job • Reset Printer • Reset Active Bin • Check Supply Levels Note: Menu Lockout does NOT prevent access to the Busy/Waiting Menu.
34 Short Paper		This message is displayed when the printer determines that the paper length is too short to print the data as formatted. The following actions can be taken: <ul style="list-style-type: none"> • Press Go to clear the error and continue printing pages or • Press Menu> or Menu< to access the Busy/Waiting Menu. The following functions are available using the Busy/Waiting Menu: <ul style="list-style-type: none"> • Cancel Job • Reset Printer • Reset Active Bin • Check Supply Levels Note: Menu Lockout does NOT prevent access to the Busy/Waiting Menu.

User primary message	User secondary message	Explanation
36 Printer Service Required		<p>This message is displayed when background toner prevents a completion of a TPS calibration cycle. Service is required to fix the problem.</p> <p>Press Go to clear the error.</p> <p>If the Service Printer message is displayed it means that a TPS failure has most likely occurred. The printer continues to operate but the color quality degrades. The most probable cause for this error message is a defective print cartridge or ITU.</p>
37 Insufficient Collation Area		<p>This message is displayed when the printer memory and disk used to store pages is too full to collate the print job.</p> <p>The following actions can be taken:</p> <ul style="list-style-type: none"> • Press Go to clear the message and continue collating the remaining pages of the job or • Press Menu> or Menu< to access the Busy/Waiting Menu. <p>The following functions are available using the Busy/Waiting Menu.</p> <ul style="list-style-type: none"> • Cancel Job • Reset Printer • Reset Active Bin • Check Supply Levels <p>Note: Menu Lockout does NOT prevent access to the Busy/Waiting Menu.</p>
37 Insufficient Defrag Memory		<p>This message is displayed when insufficient printer memory is available to perform Flash Memory Defragment operation.</p> <p>This message appears prior to the actual start of the defragment operation.</p> <p>Press Go to clear the message.</p> <p>To perform the defragment operation you can:</p> <ul style="list-style-type: none"> • Delete fonts, macros and other data in RAM • Install additional printer memory • Press Menu> or Menu< to access the Busy/Waiting Menu. <p>The following functions are available using the Busy/Waiting Menu:</p> <ul style="list-style-type: none"> • Cancel Job • Reset Printer • Reset Active Bin • Check Supply Levels <p>Note: Menu Lockout does NOT prevent access to the Busy/Waiting Menu.</p>

User primary message	User secondary message	Explanation
37 Insufficient Memory	Held Jobs May Not Be Restored	<p>These messages are displayed when the printer has attempted to print and hold jobs from the disk and found that some or all of the jobs could not be restored. Each of the three 57 Configuration Held Jobs messages describe different conditions under which the restore failed.</p> <ul style="list-style-type: none"> • Primary Message: 37 Insufficient Memory. The printer firmware ran out of memory while attempting to restore the jobs. Secondary Message: Held Jobs May Not Be Restored. • Primary Message: 57 Configuration Change—the printer firmware could not restore jobs from the disk because the configuration of the printer has changed. Secondary Message: Held Jobs May Not Be Restored. • Primary Message: Held Jobs May Not Be Restored handles any other conditions where any of the print and hold jobs could not be restored from the disk. <p>Note: Some of the print and hold jobs may not be restored. They remain on the disk but cannot be accessed.</p>
38 Memory Full		<p>This message is displayed when the printer is processing an incoming job and there is not enough memory available to continue processing the job.</p> <p>The following actions can be taken:</p> <p>You may want to determine how to make more memory available to your print job by:</p> <ul style="list-style-type: none"> • Deleting fonts, macros and other data in RAM • Simplify your print job • Install additional memory • Press Go to clear the message, however some data may be lost • Press Menu to access the Busy/Waiting Menu <p>The following functions may be available.</p> <ul style="list-style-type: none"> • Cancel Job • Reset Printer • Reset Active Bin • Check Supply Levels <p>Note: Menu Lockout does NOT prevent access to the Busy/Waiting Menu.</p>
39 Complex Page		<p>This message is displayed when a page is too complex to print.</p> <p>The following actions can be taken:</p> <ul style="list-style-type: none"> • Press Go to clear the message and continue processing the job, some data loss may occur. • Try to simply the print job <p>Press Menu> to access the Busy/Waiting Menu.</p> <p>The following functions may be available:</p> <ul style="list-style-type: none"> • Cancel Job • Reset Printer • Reset Active Bin • Check Supply Levels <p>Note: Menu Lockout does NOT prevent access to the Busy/Waiting Menu.</p>

User primary message	User secondary message	Explanation
51 Defective Flash		<p>This message is displayed when the printer detects a defective flash.</p> <p>Press Go to clear the message</p> <p>The flash is marked as bad and normal operation continues. No flash operation is allowed until the flash problem is resolved.</p>
52 Flash Full		<p>This message is displayed when there is not enough free space in the flash memory to hold the resources that have been requested to be written to flash.</p> <p>Note: The following action deletes all downloaded Fonts and Macros not written to flash:</p> <ul style="list-style-type: none"> • Press Go to clear the message and continue processing the print job. • Press Menu to access the Busy/Waiting Menu. <p>The following functions may be available:</p> <ul style="list-style-type: none"> • Cancel Job • Reset Printer • Reset Active Bin • Check Supply Levels <p>Note: Menu Lockout does NOT prevent access to the Busy/Waiting Menu.</p>
53 Unformatted Flash		<p>This message is displayed when the printer detects an unformatted flash at POST.</p> <p>Press Go to clear the message.</p> <p>The flash is marked bad and normal operation continues. Flash operations are not allowed until the flash is formatted.</p>
54 Std Par ENA Connection Lost		<p>This message is displayed when the printer detects during POST that the connection to an ENA has been lost. Once a connection is initially established, a printer setting is modified to 54 Par x ENA to note a connection exists. Each time the power is cycled on, the connection is lost.</p>
54 Std Network Software Error		<p>This message is displayed when the RIP software detects that a network port is installed but cannot establish communications with it.</p>
54 Network x Software Error		<p>Press Go to clear this message.</p> <p>The printer disables all communications to the associated network interface. No data may be received or sent from or to the associated interface. The user can program new firmware in the network using the parallel port after this message clears.</p>
54 Serial Option x Error		<p>This message is displayed when a serial error, either framing, parity or overrun, is detected on the specified (option x) serial port. This usually means the serial port is not set up correctly.</p> <p>Press Go to clear the message and continue processing the print job.</p> <p>Note: If the print job does not print correctly, make sure that the correct cable is being used. If you still have a problem go to Serial Port Service Check.</p>

User primary message	User secondary message	Explanation
56 Standard Serial Disabled 56 Serial Port x Disabled		<p>These messages may appear when data is sent to the printer across a serial port, but the port is disabled.</p> <p>Note: Once the error is displayed the first time, reporting of further errors is suppressed until the printer is reset or menus are entered.</p> <p>The following actions can be taken:</p> <ul style="list-style-type: none"> • Press Go to clear the message. Any data received on the serial port is discarded. • Press Menu to access the Busy/Waiting Menu. <p>The following functions may be available:</p> <ul style="list-style-type: none"> • Reset Printer • Reset Active Bin • Check Supply Levels <p>Note: Menu Lockout does NOT prevent access to the Busy/Waiting Menu.</p>
56 Std Parallel Port Disabled 56 Parallel Port x Disabled		<p>These messages may appear when data is sent to the printer across a parallel port, but the port is disabled.</p> <p>Note: Once the error is displayed the first time, reporting of further errors is suppressed until the printer is reset or menus are entered.</p> <p>The following actions can be taken:</p> <ul style="list-style-type: none"> • Press Go to clear the message. Any data received on the parallel port is discarded. • Press Menu to access the Busy/Waiting Menu. <p>The following functions may be available:</p> <ul style="list-style-type: none"> • Reset Printer • Reset Active Bin • Check Supply Levels <p>Note: Menu Lockout does NOT prevent access to the Busy/Waiting Menu.</p>
56 Standard USB Port Disabled 56 USB Port x Disabled		<p>These messages may appear when data is sent to the printer across the USB port, but the port is disabled.</p> <p>Note: Once the error is displayed the first time, reporting of further errors is suppressed until the printer is reset or menus are entered.</p> <p>The following actions can be taken:</p> <ul style="list-style-type: none"> • Press Go to clear the message. Any data received on the USB port is discarded • Press Menu to access the Busy/Waiting Menu. <p>The following functions may be available:</p> <ul style="list-style-type: none"> • Reset Printer • Reset Active Bin • Check Supply Levels <p>Note: Menu Lockout does NOT prevent access to the Busy/Waiting Menu.</p>
58 Too Many Trays Attached		<p>This message is displayed when too many trays are attached to the printer. Check the specifications and verify the number of trays allowed on each printer model.</p>
58 Too Many Bins Attached		<p>This message is displayed when too many optional bins are attached to the printer or if an unsupported combination of bins is installed.</p>

User primary message	User secondary message	Explanation
58 Too Many Disks Installed		This message is displayed when too many disks are installed. Note: Some configurations of different output options require the installation of one option before the other.
58 Too Many Flash Options		This message is displayed when too many Flash Options are installed. Verify the maximum number of flash memory options which may be installed. Note: Press Go to clear the message. The extra flash memory options are ignored.
59 Incompatible Output Bin x 59 Incompatible Tray x		These messages are displayed when the user installs an incompatible option. The following options may be incompatible for use on one or more 50xx models: <ul style="list-style-type: none"> • Output Bin x (x=1, 2 or 3) • Tray x (x=2,3,4 or 5) • Duplex The user is required to remove the incompatible option and press Go to clear the message. Note: If the user installed the incompatible option to satisfy a Check Option Connections/Reattach Option attendance condition, the user must reinstall an associated compatible option or hot unplug the option.
61 Defective Disk		This message is displayed when the printer detects a defective disk. This error may occur at power on, or during disk format and write operations. Press Go to clear the message. The disk is marked as defective and normal printer operation continues. Disk operations are not allowed with a defective disk and the Format Disk menu item is not shown.
62 Disk Full		This message is displayed when there is not enough free space on the disk to hold the data that have been requested to be written to the disk. This message is displayed for both resource collection and PostScript emulation when the disk is full. The following actions can be taken, however this deletes all downloaded Fonts and Macros not written to disk. <ul style="list-style-type: none"> • Press Go to clear the message and continue processing the print job • Press Menu to access the Busy/Waiting Menu The following functions may be available: <ul style="list-style-type: none"> • Cancel Job • Reset Printer • Reset Active Bin • Check Supply Levels Note: Menu Lockout does NOT prevent access to the Busy/Waiting Menu.
63 Unformatted Disk		This message is displayed when the printer detects an unformatted disk at POST. Press Go to clear the message. The disk is marked as bad and normal operation continues, however disk operation is not allowed until the disk is formatted.

User primary message	User secondary message	Explanation
64 Unsupported Disk Format		<p>This message is displayed when the printer detects an unsupported disk format at POST. This message may appear if the disk was formatted on another system with a different format.</p> <p>Press Go to clear the message.</p> <p>The disk is marked as bad and normal operation continues, however disk operations is not allowed until the disk is formatted.</p>
80 Fuser Maintenance 83 ITU Maintenance		<p>These messages are displayed when the printer requires replacement of some worn assemblies. These messages are independently posted when either the ITU or Fuser need to be replaced. Press Go to clear this message.</p>
81 Engine Code CRC Failure		<p>This message is displayed when microcode programmed into the engine flash code fails a CRC check.</p> <p>Press Go to clear the message.</p> <p>The code data is discarded and must be resent from the host computer.</p>
82 Waste Toner Bottle Full		<p>This message is displayed when the waste container is full. Replace the waste container and press Go.</p>
82 Waste Toner Bottle Missing		<p>This message is displayed when the waste container is missing. Insert the waste container and press Go.</p>
82 Waste Bottle Nearly Full		<p>This message is displayed when the waste container is nearly full.</p> <p>Press Go</p> <p>Nearly Full appears in the Supplies Menu.</p>
84 Replace Oiler		<p>This message is displayed when the web oiler is exhausted or missing. Replace the web oiler. See “Fuser web oiler motor assembly removal” on page 4-35.</p>
84 Oiler Nearly Exhausted		<p>This message is displayed when the Wed Oiler is nearly exhausted. Press Go to continue or replace the web oiler. See “Fuser web oiler motor assembly removal” on page 4-35.</p>
87 Fuser Missing		<p>This message is displayed when the engine detects the fuser is missing.</p> <p>Turn the printer off and insert the fuser assembly.</p>
88 Yellow Toner Low 88 Magenta Toner Low 88 Cyan Toner Low 88 Black Toner Low		<p>These messages are displayed when either the yellow, magenta, cyan, or black toner cartridge is low on toner.</p> <p>The following actions can be taken:</p> <ul style="list-style-type: none"> • Open the front door, remove the old toner cartridge, insert a new toner cartridge, and close the door or • Press Go without changing the toner cartridge and continue.
1565 Emul Error Load Emul Option		<p>This message appears when the IPDS emulation version contained in the SIMM does not function with the printer code. This message automatically clears in 30 seconds, and the IPDS emulation is disabled. No other printer functions are affected. The correct IPDS emulation must be downloaded.</p>

Service checks

100 ITU Error

A 100 ITU error indicates that the printer did not detect the ITU belt home sensor. Before proceeding with this service check make sure that the Second Transfer Roll is correctly installed. After you reinstall the Second Transfer Roll, check to see if a 100 ITU error is still displayed. If a 100 ITU error is still being displayed, continue with this check.

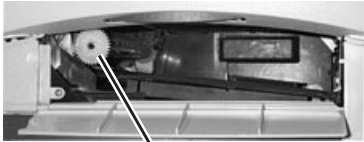
Step	Action and questions	Yes	No
1	<p>Make sure all packing material is removed from the printer. The detensioner is packing material located underneath the toner cartridges. Make sure the ITU detensioner is removed. Remove the detensioner by pulling up on the red handle on the right side of the ITU.</p> <p>Note: All the print cartridges must be removed to gain access to the detensioner packing material.</p> <p>Has all packing material been removed from the printer?</p>	Go to step 2	Remove any remaining packing material from the printer
2	<p>Check the printer is setting on a solid flat surface.</p> <p>Is the printer setting on a solid flat surface?</p>	Go to step 3	Go to step 4
3	<p>Inform the customer that the printer must be setting on a solid flat surface or install the printer on a solid flat surface as available.</p> <p>Recheck the printer to see if a 100 ITU error is still displayed.</p> <p>Is a 100 ITU error still displayed?</p>	Go to step 4	Problem solved
4	<p>Make sure the ITU cleaner gear (A) is turning. Observe the gear by opening the front paper jam door above the integrated paper tray 1. Observe the white cleaner gear during POR. The gear should turn slowly and smoothly for approximately 8 seconds before the printer displays a 100 ITU error.</p>  <p>Is the ITU Cleaner Gear turning?</p>	Go to step 5	Go to step 9
5	<p>Check the ITU release lever for correct operation. The ITU release lever is the blue lever located on the left upper side frame above the ITU opening and can be seen by opening and lowering the MPF assembly. When locked the lever should be at the 6 o'clock position. When unlocked it should be in a 3 o'clock position. Undue pressure is not required to operate the lever.</p> <p>Does the ITU release lever operate correctly?</p>	Go to step 6	Repair as necessary

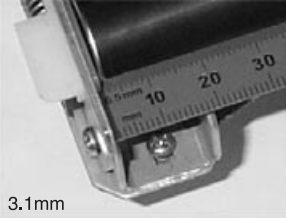
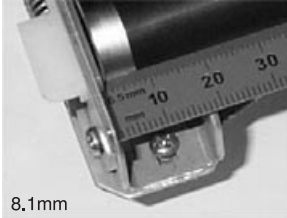
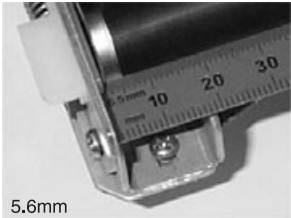
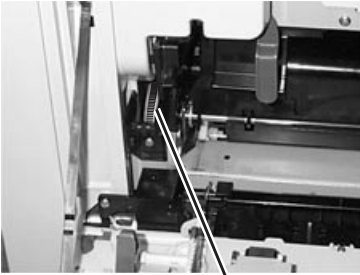
Step	Action and questions	Yes	No
6	<p>Remove the ITU assembly and check that the sensor cables are seated in the handle of the ITU assembly correctly.</p> <p>Note: The sensor connectors are located on the side of the ITU handle assembly.</p> <p>Are the cables seated correctly?</p>	Go to step 7	Reinstall the cables correctly. Recheck for a 100 ITU error. If 100 ITU is displayed, go to step 11.
7	<p>The front contamination shield is attached to the front plate of the ITU frame and lies on the top of the ITU belt.</p> <p>Is the front contamination shield lying on the ITU belt?</p>	Go to step 8	Position the shield on top of the belt
8	<p>Remove the ITU and check the ITU belt position. If the belt has shifted front to rear it should be replaced. The belt must not shift more than 4 mm in either direction. Check by making the measurements as shown. The lower limit is 3.1 mm, the high limit is 8.1 mm, and the optimum position is 5.6 mm.</p> <div style="display: flex; justify-content: space-around;">   </div> <div style="text-align: center; margin: 10px 0;">  <p>5.6mm</p> </div> <p>Has the ITU belt shifted front to rear?</p>	Replace the ITU assembly. See “ITU assembly removal” on page 4-37	Go to step 12
9	<p>Check to see if the ITU drive roll gear (A) is turning during POR. Observe the gear by opening the MFP door to its horizontal position. Observe the gear on the left end of the ITU Drive Roll. The ITU drive roll gear should turn for a few seconds slowly and smoothly before the printer posts a 100 ITU error.</p> <div style="text-align: center; margin: 10px 0;">  <p>A</p> </div> <p>Does the gear turn?</p>	Go to step 10	Go to step 10

Step	Action and questions	Yes	No
10	Check to see if the ITU drive motor is turning during POR. Observe the ITU motor during POR by removing the rear cover. Is the ITU drive motor turning?	Replace the ITU assembly. See "ITU assembly removal" on page 4-37	Go to step 11
11	Make sure the ITU drive motor assembly cable is correctly installed to the ITU drive motor and at connector location J64 on the engine board. Is the cable correctly installed?	Go to step 12	Install the cable correctly
12	Make sure the ITU autoconnect cable is installed correctly at connector location J72 on the engine board. Is the cable correctly installed?	Go to step 13	Install the cable correctly
13	Make sure the ITU autoconnect connector in the printer is seated correctly in the connector plate. Is the connector seated correctly?	Go to step 14	Install the connector/cable correctly
14	Check continuity of the ITU autoconnect cable. Is there continuity?	Replace the following FRUs in the order shown: 1. ITU assembly. See "ITU assembly removal" on page 4-37 2. Engine board. See "Engine board removal" on page 4-29	Replace the ITU autoconnect cable

120 Error code

An incorrect hot roll lamp is installed.

CAUTION: Make sure the lamp is cool before removing it from the assembly.

The Hot Roll and Backup Roll may have the wrong voltage lamp installed.

Step	Action and questions	Yes	No
1	Is the correct fuser assembly installed in the printer? See "Fuser" on page 7-8 for the part number.	Go to step 2	Install the correct fuser assembly. See "Fuser assembly removal" on page 4-31 .
2	Is the correct fuser hot roll lamp installed in the fuser assembly? See "Fuser" on page 7-8 for the part number.	Go to step 3	Install the correct fuser lamp in the fuser assembly.

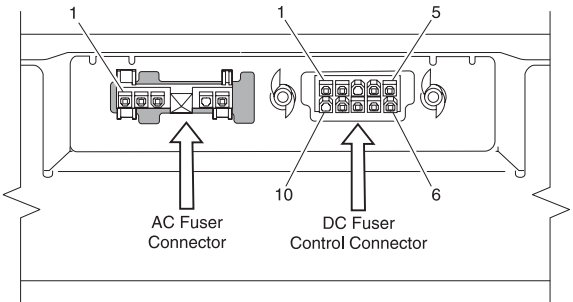
Step	Action and questions	Yes	No
3	<p>Check for continuity between pins 1 and 2 on the AC fuser connector located on the fuser assembly.</p>  <p>Is there continuity?</p>	<p>Replace the LVPS assembly. See “Low voltage power supply (LVPS) removal” on page 4-38.</p>	<p>Replace the fuser assembly. See “Fuser assembly removal” on page 4-31.</p>

121 Error code

An incorrect fuser backup roll lamp is installed.

CAUTION: Make sure the lamp is cool before removing it from the assembly.

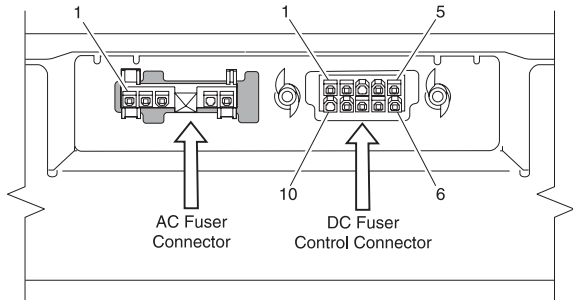
Step	Action and questions	Yes	No
1	Is the correct fuser assembly installed in the printer?	Go to step 2	Install the correct fuser assembly. See “Fuser assembly removal” on page 4-31.
2	Is the correct fuser backup roll lamp installed in the fuser assembly?	Go to step 3	Install the correct fuser backup lamp.
3	<p>Check for continuity between pins 2 and 5 on the AC fuser connector located on the fuser assembly.</p>  <p>Do you have continuity?</p>	<p>Replace the LVPS assembly. See “Low voltage power supply (LVPS) removal” on page 4-38.</p>	<p>Replace the fuser assembly. See “Fuser assembly removal” on page 4-31.</p>

122 Error code

The printer has detected a problem in the fuser hot roll lamp circuitry, backup roll fuser circuitry, fuser hot roll thermistor, backup roll thermistor, engine board, or LVPS fuser control circuits.

Replace the FRUs in the order shown:

1. Fuser assembly. See **“Fuser assembly removal” on page 4-31.**
2. LVPS assembly. See **“Low voltage power supply (LVPS) removal” on page 4-38.**
3. Engine board. See **“Engine board removal” on page 4-29.**

123 Error code

Cold fuser

The printer has detected a problem in the fuser hot roll lamp circuits, backup roll fuser lamp circuits, fuser hot roll thermistor, backup roll thermistor, engine board, or LVPS fuser control circuits.

Replace the FRUs in the order shown:

1. Fuser assembly. See **“Fuser assembly removal” on page 4-31.**
2. LVPS assembly. See **“Low voltage power supply (LVPS) removal” on page 4-38.**
3. Engine board. See **“Engine board removal” on page 4-29.**

124 Error code

Hot fuser

The printer detects a problem with the fuser running over temperature or the hot roll fuser lamp has been on too long. A problem may exist in the fuser assembly with the hot roll bearings, the hot roll thermistor, or other hot roll parts. The LVPS or engine board assembly can also be failing.

Step	Action and questions	Yes	No
1	Open the right fuser access door. Observe the fuser and see if the hot roll lamp turns on and off. You may have to observe the fuser for a few minutes. Does the hot roll lamp turn off and on?	Go to step 2	Replace the LVPS assembly. See “Low voltage power supply (LVPS) removal” on page 4-38.
2	Turn the printer on and measure the voltage on connector J10-11 on the engine board. The voltage should measure approximately +0.13 V dc to +0.64 V dc as the hot roll lamp turns on and off. Is the voltage correct?	Replace the fuser assembly. See “Fuser assembly removal” on page 4-31.	Replace the engine board assembly. See “Engine board removal” on page 4-29.

125 Error code

Hot fuser

The printer detects a problem with the fuser running over temperature or the backup rolls have been on too long. A problem could exist in the fuser assembly with the backup roll bearings, backup roll thermistor, or other backup roll parts. The LVPS or engine board assembly may also be failing.

Step	Action and questions	Yes	No
1	Open the right fuser access door. Observe the fuser and see if the backup roll lamp turns on and off. You may have to observe the fuser for a few minutes. Does the backup roll lamp turn off and on?	Go to step 2	Replace the LVPS assembly. See “Low voltage power supply (LVPS) removal” on page 4-38.
2	Turn the printer on and measure the voltage on connector J10-12 on the engine board. The voltage should measure approximately +0.13 V dc to +0.64 V dc as the hot roll lamp turns on and off. Is the voltage correct?	Replace the fuser assembly. See “Fuser assembly removal” on page 4-31.	Replace the engine board assembly. See “Engine board removal” on page 4-29.

126 Error code

Hot roll thermistor or thermistor circuits are open

The printer detects a problem in the fuser hot roll, hot roll lamp circuits, fuser hot roll thermistor, engine board, or LVPS fuser control circuits.

Step	Action and questions	Yes	No
1	Turn the printer on and allow it to reach Ready. Note: The printer may not complete POR and post a 126 error message. Remove the fuser assembly from the printer and measure the voltage on connector J10-6 on the engine board. See “Fuser connectors” on page 5-25. The voltage should measure approximately +3.3 V dc. Is the voltage correct?	Go to step 2	Replace the engine board. See “Engine board removal” on page 4-29.
2	Measure the voltage on the fuser DC control connector on the LVPS. Measure the voltage on pin 6 of the connector. The voltage should measure approximately +3.3 V dc. Is the voltage correct?	Replace the fuser assembly. See “Fuser assembly removal” on page 4-31.	Replace the LVPS assembly. “Low voltage power supply (LVPS) removal” on page 4-38.

127 Error code**Backup roll thermistor or thermistor circuits are open**

The printer detects a problem in the fuser back up roll, circuits, fuser backup roll thermistor, engine board, or LVPS fuser control circuits.

Step	Action and questions	Yes	No
1	<p>Turn the printer on and allow it to reach Ready.</p> <p>Note: The printer may not complete POR and post a 127 error message.</p> <p>Remove the fuser assembly from the printer and measure the voltage on connector J10-7 on the engine board. The voltage should measure approximately +3.3 V dc.</p> <p>Is the voltage correct?</p>	Go to step 2	Replace the engine board. See “Engine board removal” on page 4-29.
2	<p>Measure the voltage on pin 7 of the fuser DC control connector. See “Engine board” on page 5-7. The voltage should measure approximately +3.3 V dc.</p> <p>Is the voltage correct?</p>	Replace the fuser assembly. See “Fuser assembly removal” on page 4-31.	Replace the LVPS. See “Low voltage power supply (LVPS) removal” on page 4-38.

128 Error code

Fuser hot roll is under temperature during standby.

Step	Action and questions	Yes	No
1	<p>Turn the printer on to allow it to reach Ready.</p> <p>Note: The printer may not complete POR and continue to display a 128 error message.</p> <p>Remove the fuser assembly from the printer and measure the voltage on connector J10-6 on the engine board. The voltage should measure approximately +3.3 V dc.</p> <p>Is the voltage correct?</p>	Go to step 2	Replace the engine board assembly. See “Engine board removal” on page 4-29.
2	<p>Measure the voltage on pin 6 of the fuser DC control connector on the LVPS. The voltage should measure approximately +3.3 V dc.</p> <p>Is the voltage correct?</p>	Replace the fuser assembly. See “Fuser assembly removal” on page 4-31.	Replace the LVPS assembly. See “Low voltage power supply (LVPS) removal” on page 4-38.

129 Error code

The fuser backup roll is under temperature during standby. Replace the fuser top duct. See **“Fuser top duct removal” on page 4-34.**

Step	Action and questions	Yes	No
1	<p>Turn the printer on and allow it to reach Ready.</p> <p>Note: The printer may not complete POR and continue to display the 129 error message.</p> <p>Remove the fuser assembly from the printer and measure the voltage on connector J10-7 on the engine board. The voltage should measure approximately +3.3 V dc.</p> <p>Is the voltage correct?</p>	Go to step 2	Replace the engine board assembly. See “Engine board removal” on page 4-29.
2	<p>Measure the voltage on pin 7 of the DC control connector on the LVPS. The voltage should measure approximately +3.3 V dc.</p> <p>Is the voltage correct?</p>	Replace the fuser assembly. See “Fuser assembly removal” on page 4-31.	Replace the LVPS assembly. See “Low voltage power supply (LVPS) removal” on page 4-38.

130 Error code

Hot roll did not reach the correct standby temperature

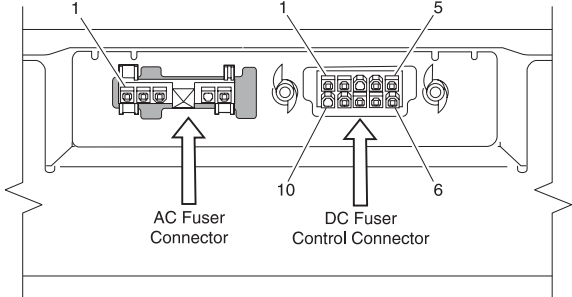
Step	Action and questions	Yes	No
1	<p>Measure the voltage on connector J10-11 on the engine board. The voltage should measure approximately +0.13 V dc to +0.64 V dc as the hot roll lamp turn on and off.</p>  <p>AC Fuser Connector DC Fuser Control Connector</p> <p>Is the voltage correct?</p>	<p>Replace the fuser assembly. See “Fuser assembly removal” on page 4-31</p>	<p>Go to step 2</p>
2	<p>Remove the fuser from the printer. Check continuity of the hot roll lamp by measuring between pins 1 and 2 on the AC fuser connector on the fuser assembly.</p> <p>Is there continuity?</p>	<p>Go to step 3</p>	<p>Go to step 4</p>
3	<p>Make sure the hot roll lamp is installed correctly.</p> <p>Is the lamp installed correctly?</p>	<p>Go to step 4</p>	<p>Install the lamp correctly.</p>
4	<p>Carefully remove the lamp from the fuser assembly, being careful to only handle the lamp by the ceramic end pieces and not by the glass envelope.</p> <p>Warning: Use caution when handling the lamp as it is easily broken.</p> <p>Check continuity of the lamp.</p> <p>Is there continuity?</p>	<p>Replace the fuser assembly. See “Fuser assembly removal” on page 4-31.</p>	<p>Replace the lamp.</p>
5	<p>Reinstall the fuser assembly. Watch to see if the lamps turn on and off as the lap heats up.</p> <p>Do the lamps turn on and off?</p>	<p>Go to step 6</p>	<p>Replace the LVPS assembly. See “Low voltage power supply (LVPS) removal” on page 4-38.</p>
6	<p>Turn the printer on and off and allow it to reach Ready.</p> <p>Note: The printer may not complete POR and continue to display a 130 error.</p> <p>Remove the fuser assembly from the printer and measure the voltage on connector J10-6 on the engine board. The voltage should measure approximately +3.3 V dc.</p> <p>Is the voltage correct?</p>	<p>Go to step 7</p>	<p>Replace the engine board. See “Engine board removal” on page 4-29.</p>
7	<p>Measure the voltage on pin 6 of the fuser DC control connector. The voltage should measure approximately +3.3 V dc.</p> <p>Is the voltage correct?</p>	<p>Replace the fuser assembly. See “Fuser assembly removal” on page 4-31.</p>	<p>Replace the LVPS assembly. See “Low voltage power supply (LVPS) removal” on page 4-38.</p>

131 Error code

The fuser backup roll does not reach the correct standby temperature.

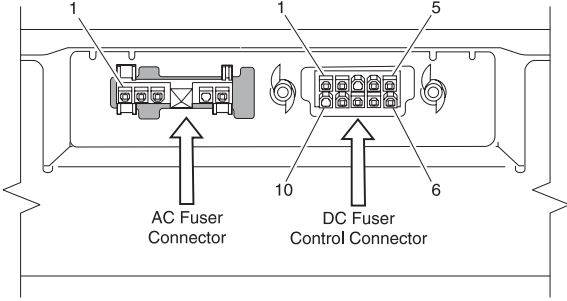
Step	Action and questions	Yes	No
1	<p>Measure the voltage on connector J10-12 on the engine board. See “Engine board” on page 5-7 for the location of the connector. The voltage should measure approximately +0.13 V dc to 0.64 V dc as the backup roll lamp turns on and off.</p> <p>Is the voltage correct?</p>	Replace the fuser assembly. See “Fuser assembly removal” on page 4-31.	Go to step 2
2	<p>Remove the fuser from the printer. Check the continuity of the backup roll lamp by measuring between pins 2 and 5 on the AC fuser connector on the fuser assembly.</p>  <p>Is there continuity?</p>	Go to step 5	Go to step 3
3	<p>Check to make sure the backup roll lamp is installed correctly.</p> <p>Is the lamp installed correctly?</p>	Go to step 4	Install the lamp correctly.
4	<p>Carefully remove the lamp from the fuser assembly, being careful to only handle the lamp by the ceramic end pieces and not by the glass envelope.</p> <p>Warning: Use caution when handling the lamp as it is easily broken.</p> <p>Check the continuity of the backup roll lamp.</p> <p>Is there continuity?</p>	Replace the fuser assembly. See “Fuser assembly removal” on page 4-31.	Replace the backup roll lamp.
5	<p>Reinstall the fuser assembly. Watch to see if the lamps turn on and off as the lamps heat up.</p> <p>Do the lamps turn on and off?</p>	Go to step 6	Replace the LVPS assembly. See “Low voltage power supply (LVPS) removal” on page 4-38.
6	<p>Turn the printer on and allow it to reach Ready.</p> <p>Note: The printer may not complete POR and continues to display a 131 error.</p> <p>Remove the fuser assembly from the printer and measure the voltage on connector J10-7 on the engine board. The voltage should measure approximately +3.3 V dc.</p> <p>Is the voltage correct?</p>	Go to step 7	Replace the engine board assembly. See “Engine board removal” on page 4-29.

Step	Action and questions	Yes	No
7	Measure the voltage on pin 7 of the fuser DC control connector. The voltage should measure approximately +3.3 V dc. Is the voltage correct?	Replace the fuser assembly. See “Fuser assembly removal” on page 4-31.	Replace the LVPS assembly. See “Low voltage power supply (LVPS) removal” on page 4-38.

132 Error code

Cold fuser hot roll

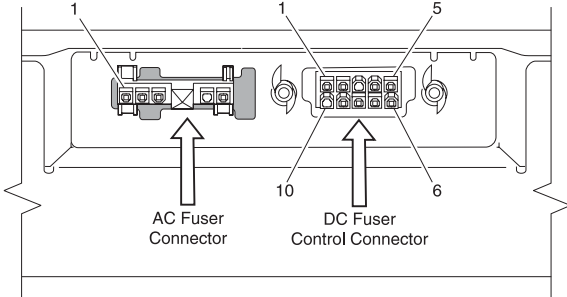
Step	Action and questions	Yes	No
1	Measure the voltage on connector J10-11 on the engine board. The voltage should measure approximately +0.13 V dc to 0.64 V dc as the hot roll lamp turns on and off. Is the voltage correct?	Replace the fuser assembly. See “Fuser assembly removal” on page 4-31.	Go to step 2
2	Remove the fuser from the printer. Check continuity of the hot roll lamp by measuring between pins 1 and 2 on the AC fuser connector on the fuser assembly.  Is there continuity?	Go to step 5	Go to step 3
3	Make sure the hot roll lamp is installed correctly. Is the lamp installed correctly?	Go to step 4	Install the hot roll lamp correctly.
4	Carefully remove the lamp from the fuser assembly, being careful to only handle the lamp by the ceramic end pieces and not by the glass envelope. Warning: Use caution when handling the lamp, as it is easily broken. Check continuity of the hot roll lamp. Is there continuity?	Replace the fuser assembly. See “Fuser assembly removal” on page 4-31.	Replace the hot roll lamp.
5	Reinstall the fuser assembly. Watch to see if the lamps turn on and off as the lamps heat up. Do the lamps turn on and off?	Go to step 6	Replace the LVPS assembly. See “Low voltage power supply (LVPS) removal” on page 4-38.

Step	Action and questions	Yes	No
6	Turn the print on and allow it to reach Ready. Note: The printer may not complete POR and continues to display a 132 error. Remove the fuser assembly from the printer and measure the voltage on connector J10-6 on the engine board. The voltage should measure approximately +3.3 V dc. Is the voltage correct?	Go to step 7	Replace the engine board assembly. See “Engine board removal” on page 4-29.
7	Measure the voltage on pin 6 of the fuser DC control connector. The voltage should measure approximately +3.3 V dc. Is the voltage correct?	Replace the fuser assembly. See “Fuser assembly removal” on page 4-31.	Replace the LVPS assembly. See “Low voltage power supply (LVPS) removal” on page 4-38.

133 Error code

Cold fuser backup roll

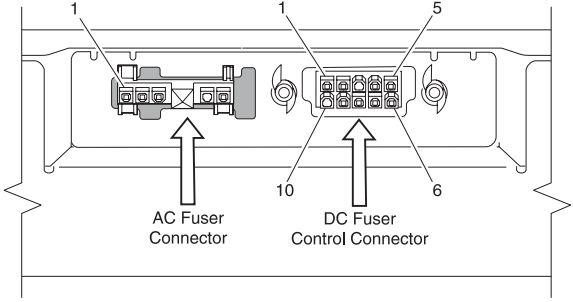
Step	Action and questions	Yes	No
1	Measure the voltage on connector J10-12 on the engine board. The voltage should measure approximately +0.13 V dc to +0.64 V dc as the backup roll lamp turns on and off. Is the voltage correct?	Replace the fuser assembly. See “Fuser assembly removal” on page 4-31.	Go to step 2
2	Remove the fuser from the printer. Check continuity of the hot roll lamp by measuring between pins 2 and 5 on the AC fuser connector on the fuser assembly.  Is there continuity?	Go to step 5	Go to step 3
3	Check to make sure the backup roll lamp is installed correctly. Is the lamp installed correctly?	Go to step 4	Install the backup roll lamp correctly.
4	Carefully remove the lamp from the fuser assembly, being careful to only handle the lamp by the ceramic end pieces and not the glass envelope. Warning: Use caution when handling the lamp as it is easily broken. Check continuity of the backup roll lamp. Is there continuity?	Replace the fuser assembly. See “Fuser assembly removal” on page 4-31.	Replace the backup lamp.

Step	Action and questions	Yes	No
5	Reinstall the fuser assembly. Watch to see if the lamps turn on and off as the lamps heat up. Do the lamps turn on and off?	Go to step 6	Replace the LVPS assembly. See “Low voltage power supply (LVPS) removal” on page 4-38.
6	Turn the printer on and allow it to reach Ready. Note: The printer may not complete POR and continues to display a 133 error. Remove the fuser assembly from the printer and measure the voltage on connector J10-7 on the engine board. The voltage should measure approximately +3.3 V dc. Is the voltage correct?	Go to step 7	Replace the engine board assembly. See “Engine board removal” on page 4-29.
7	Measure the voltage on pin 7 of the fuser DC control connector. The voltage should measure approximately +3.3 V dc. Is the voltage correct?	Replace the fuser assembly. See “Fuser assembly removal” on page 4-31.	Replace the LVPS assembly. See “Low voltage power supply (LVPS) removal” on page 4-38.

134 Error code

Hot fuser

The fuser is running over temperature or the hot roll fuser lamp has been on too long. Error code 134 may also indicate a problem in the fuser assembly with the hot roll fuser bearings, hot roll thermistor, LVPS, or engine board.

Step	Action and questions	Yes	No
1	Turn the printer on, open the right side fuser access door and observe the hot roll lamp to see if it turns on and off. You may have to observe the lamp for a few minutes to see if it turns on and off. Does the lamp turn on and off?	Go to step 2	Replace the LVPS assembly. See “Low voltage power supply (LVPS) removal” on page 4-38.
2	Turn the printer on. Measure the voltage on engine board connector J10-11. The voltage should measure approximately +0.13 V dc to +0.64 V dc as the hot roll lamp turns on and off. Does the voltage change?	Replace the fuser assembly. See “Fuser assembly removal” on page 4-31.	Replace the engine board assembly. See “Engine board removal” on page 4-29.

135 Error code

Hot fuser

The fuser assembly is running over temperature or the backup roll fuser lamp has been on too long. Error 135 may also indicate a problem in the fuser assembly with the backup roll fuser bearings, backup roll thermistor, LVPS, or engine board.

Step	Action and questions	Yes	No
1	Turn the printer on, open the right side fuser access door and observe the backup roll lamp to see if it turns on and off. You may have to observe the lamp for a few minutes to see if it turns on and off. Does the lamp turn on and off.	Go to step 2	Replace the LVPS assembly. See “Low voltage power supply (LVPS) removal” on page 4-38.
2	Turn the printer on. Measure the voltage on engine board connector J10-12. The voltage should be approximately +0.13 V dc to +0.64 V dc as the backup roll turns on and off. Does the voltage change?	Replace the fuser assembly. See “Fuser assembly removal” on page 4-31.	Replace the engine board assembly. See “Engine board removal” on page 4-29.

136 Error code

Fuser assembly cam position is not found

Step	Action and questions	Yes	No						
1	Observe the fuser drive assembly gears rotate during POR. Do the gears rotate?	Go to step 2	Go to step 6						
2	Do the gears stop and the fuser drive assembly gears make a loud <i>buzzing</i> sound?	Replace the fuser assembly. See “Fuser assembly removal” on page 4-31	Go to step 3						
3	Check for correct installation of the fuser control cable to J10 on the engine board. Is the cable installed correctly?	Go to step 4	Install the cable correctly.						
4	Enter the diagnostic mode. Measure the voltage on the engine board connector J10-2. The voltage should measure approximately +5 V dc. Is the voltage correct?	Go to step 5	Replace the engine board assembly. See “Engine board removal” on page 4-29.						
5	Remove the fuser from the printer. Measure the voltage at the DC fuser control connector, pins 2 and 9. The voltage should measure approximately +5 V dc. Is the voltage correct?	Replace the fuser assembly. See “Fuser assembly removal” on page 4-31.	Replace the LVPS assembly. See “Low voltage power supply (LVPS) removal” on page 4-38.						
6	Check for correct installation of the fuser drive motor cable to connector J8 on the engine board. Is the cable installed correctly?	Go to step 7	Install the cable correctly.						
7	Remove the fuser fan to gain access to the fuser drive motor cable. Check the cable for correct installation to J1 on the fuser drive motor assembly. Is the cable installed correctly?	Go to step 8	Install the cable correctly.						
8	Enter CE Diagnostic mode and measure the following voltages on connector J8. Voltages are approximate. <table border="1" data-bbox="375 1413 646 1520"> <thead> <tr> <th>Pin</th> <th>Voltage</th> </tr> </thead> <tbody> <tr> <td>J8-8</td> <td>+24 V dc</td> </tr> <tr> <td>J8-4</td> <td>+5 V dc</td> </tr> </tbody> </table> Are the voltages correct?	Pin	Voltage	J8-8	+24 V dc	J8-4	+5 V dc	Replace the fuser drive assembly. See “Fuser drive assembly removal” on page 4-33.	Replace the engine board assembly. See “Engine board removal” on page 4-29.
Pin	Voltage								
J8-8	+24 V dc								
J8-4	+5 V dc								

148 Error code

Step	Action and questions	Yes	No																
1	Connector J64 on the engine board—check for correct installation of the ITU drive motor cable from the ITU drive motor to the engine board connector J64. Is the cable connected correctly?	Go to step 2	Install the cable correctly																
2	ITU drive motor—check for continuity between pin 4 of CON1 on the motor drive card and the remaining pins in the connector. Do you measure continuity? Note: The ITU drive motor can be removed from the printer without removing the complete ITU drive motor assembly. If the ITU drive motor assembly is removed be careful not to spill toner that may be contained in the auger system.	Replace the drive motor	Go to step 3																
3	ITU drive motor cable—check the continuity of the ITU drive motor cable. Do you measure continuity?	Go to step 4	Replace the ITU drive motor cable																
4	ITU drive motor voltage check—measure the voltage on connector J64 on the engine board. The voltages are approximately values. Voltages motor not running <table border="1" data-bbox="431 957 883 1234"> <thead> <tr> <th>Connector pin</th> <th>Voltages (motor not running)</th> </tr> </thead> <tbody> <tr> <td>J64-2</td> <td>+4.2 V dc</td> </tr> <tr> <td>J64-4</td> <td>+5.0 V dc</td> </tr> <tr> <td>J64-6</td> <td>+3.3 V dc</td> </tr> <tr> <td>J64-8</td> <td>+24 V dc</td> </tr> <tr> <td>J64-10</td> <td>Ground</td> </tr> <tr> <td>J64-12</td> <td>0 V dc</td> </tr> <tr> <td>J64-14</td> <td>+3.3 V dc</td> </tr> </tbody> </table> Are the voltages correct?	Connector pin	Voltages (motor not running)	J64-2	+4.2 V dc	J64-4	+5.0 V dc	J64-6	+3.3 V dc	J64-8	+24 V dc	J64-10	Ground	J64-12	0 V dc	J64-14	+3.3 V dc	Replace the drive motor	Go to step 5
Connector pin	Voltages (motor not running)																		
J64-2	+4.2 V dc																		
J64-4	+5.0 V dc																		
J64-6	+3.3 V dc																		
J64-8	+24 V dc																		
J64-10	Ground																		
J64-12	0 V dc																		
J64-14	+3.3 V dc																		
5	ITU motor drive assembly—remove the ITU assembly. Manually turn the motor. The gears in the ITU motor assembly, the second transfer roll gears, and the cleaner gear should turn freely. Do the gears turn freely?	Replace the engine board. If this does not fix the problem, replace the ITU drive motor.	Go to step 6																
6	ITU motor drive assembly—remove the ITU drive motor assembly. Manually turn the motor. Do the gears on the ITU drive motor assembly turn freely?	Contact your next level support	Replace the ITU motor drive assembly																

149 Error code

Step	Action and questions	Yes	No
1	Connector J8 on the engine board—make sure that the fuser drive motor cable is correctly connected to J8 on the engine board. Go to “Engine board” on page 5-7. Is the cable connected correctly?	Go to step 2	Correctly install the cable
2	FRU replacement—replace the following FRUs in the order shown: 1. “Fuser drive assembly removal” on page 4-33. 2. “Engine board removal” on page 4-29.		

150 Error code

Black cartridge drive assembly

The black cartridge drive motor has either failed to lock or has lost lock.

Note: Any time any of the cartridge drive motor assemblies are replaced, perform the **“Motor Detect” on page 3-16.** If this procedure is not performed, error code 168 is displayed.

Step	Actions and questions	Yes	No
1	Check the black cartridge drive motor cable connection to J64 on the engine board. Is the cable installed correctly?	Go to step 2	Install the cable correctly
2	Check the black cartridge drive motor cable connection to the black cartridge drive motor card. Is the cable installed correctly?	Go to step 3	Install the cable correctly
3	Check continuity of the black cartridge drive motor cable. Is there continuity?	Go to step 4	Replace the black cartridge assembly cable
4	Replace the black cartridge drive assembly. Perform the “Motor Detect” on page 3-16. Does this fix the problem?	Problem solved	Go to step 5
5	Replace the engine board. Does this fix the problem?	Problem solved	Call your next level support

151 Error code

Magenta cartridge drive assembly

The magenta cartridge drive motor has either failed to lock or has lost lock.

Note: Any time any of the cartridge drive motor assemblies are replaced perform the **“Motor Detect”** on **page 3-16**. If this procedure is not performed, error code 168 is displayed.

Step	Actions and questions	Yes	No
1	Check the magenta cartridge drive motor cable connection to J47 on the engine board. Is the cable installed correctly?	Go to step 2	Install the cable correctly
2	Check the magenta cartridge drive motor cable connection to the magenta cartridge drive motor card. Is the cable installed correctly?	Go to step 3	Install the cable correctly
3	Check continuity of the magenta cartridge drive motor cable. Is there continuity?	Go to step 4	Replace the magenta cartridge assembly cable
4	Replace the magenta cartridge drive assembly. Perform the “Motor Detect” on page 3-16 . Does this fix the problem?	Problem solved	Go to step 5
5	Replace the engine board. Does this fix the problem?	Problem solved	Call your next level support

152 Error code

Cyan cartridge drive assembly

The cyan cartridge drive motor has either failed to lock or has lost lock.

Note: Any time any of the cartridge drive motor assemblies are replaced, perform the **“Motor Detect”** on **page 3-16**. If this procedure is not performed, error code 168 is displayed.

Step	Actions and questions	Yes	No
1	Check the cyan cartridge drive motor cable connection to J47 on the engine board. Is the cable installed correctly?	Go to step 2	Install the cable correctly
2	Check the cyan cartridge drive motor cable connection to the cyan cartridge drive motor card. Is the cable installed correctly?	Go go step 3	Install the cable correctly
3	Check continuity of the cyan cartridge drive motor cable. Is there continuity?	Go to step 4	Replace the cyan cartridge assembly cable
4	Replace the cyan cartridge drive assembly. Perform “Motor Detect” on page 3-16 . Does this fix the problem?	Problem solved	Go to step 5

Step	Actions and questions	Yes	No
5	Replace the engine board. Does this fix the problem?	Problem solved	Call your next level support

153 Error code

Yellow cartridge drive assembly

The yellow cartridge drive motor has either failed to lock or lost lock.

Note: Any time any of the cartridge drive motor assemblies are replaced, perform the **“Motor Detect” on page 3-16**. If this procedure is not performed, error code 168 is displayed.

Step	Actions and questions	Yes	No
1	Check the yellow cartridge drive motor cable connection to J47 on the engine board. Is the cable installed correctly?	Go to step 2	Install the cable correctly
2	Check the yellow cartridge drive motor cable connection to the yellow cartridge drive motor card. Is the cable installed correctly?	Go to step 3	Install the cable correctly
3	Check continuity of the yellow cartridge drive motor cable. Is there continuity?	Go to step 4	Replace the yellow cartridge assembly cable
4	Replace the yellow cartridge drive assembly. Perform “Motor Detect” on page 3-16 . Does this fix the problem?	Problem solved	Go to step 5
5	Replace the engine board. Does this fix the problem?	Problem solved	Call your next level support

154 Error code

ITU belt motor

Step	Action and questions	Yes	No																
1	Connector J64 on the engine board—check for correct installation of the ITU drive motor cable from the ITU drive motor to the engine board connector J64. Is the cable connected correctly?	Go to step 2	Install the cable correctly																
2	ITU drive motor—check for continuity between pin 4 of CON1 on the motor drive card and the remaining pins in the connector. Do you measure continuity? Note: The ITU drive motor can be removed from the printer without removing the complete ITU drive motor assembly. If the ITU drive motor assembly is removed be careful not to spill toner that may be contained in the auger system.	Replace the drive motor	Go to step 3																
3	ITU drive motor cable—check the continuity of the ITU drive motor cable. Do you measure continuity?	Go to step 4	Replace the ITU drive motor cable																
4	ITU drive motor voltage check—measure the voltage on connector J64 on the engine board. The voltages are approximately values. Voltages Motor not running <table border="1"> <thead> <tr> <th>Connector pin</th> <th>Voltages (motor not running)</th> </tr> </thead> <tbody> <tr> <td>J64-2</td> <td>+4.2 V dc</td> </tr> <tr> <td>J64-4</td> <td>+5.0 V dc</td> </tr> <tr> <td>J64-6</td> <td>+3.3 V dc</td> </tr> <tr> <td>J64-8</td> <td>+24 V dc</td> </tr> <tr> <td>J64-10</td> <td>Ground</td> </tr> <tr> <td>J64-12</td> <td>0 V dc</td> </tr> <tr> <td>J64-14</td> <td>+3.3 V dc</td> </tr> </tbody> </table> Are the voltages correct?	Connector pin	Voltages (motor not running)	J64-2	+4.2 V dc	J64-4	+5.0 V dc	J64-6	+3.3 V dc	J64-8	+24 V dc	J64-10	Ground	J64-12	0 V dc	J64-14	+3.3 V dc	Replace the drive motor	Go to step 5
Connector pin	Voltages (motor not running)																		
J64-2	+4.2 V dc																		
J64-4	+5.0 V dc																		
J64-6	+3.3 V dc																		
J64-8	+24 V dc																		
J64-10	Ground																		
J64-12	0 V dc																		
J64-14	+3.3 V dc																		
5	ITU motor drive assembly—remove the ITU assembly. Manually turn the motor. The gears in the ITU motor assembly, the second transfer roll gears, and the cleaner gear should turn freely. Do the gears turn freely?	Replace the engine board. If this does not fix the problem, replace the ITU drive motor.	Go to step 6																
6	ITU motor drive assembly—remove the ITU drive motor assembly. Manually turn the motor. Do the gears on the ITU drive motor assembly turn freely?	Contact your next level support	Replace the ITU motor drive assembly																

155 Error code

Hot fuser

Step	Action and questions	Yes	No
1	Connector J8 on the engine board—make sure that the fuser drive motor cable is correctly connected to J8 on the engine board. Go to “Engine board” on page 5-7. Is the cable connected correctly?	Go to step 2	Correctly install the cable
2	FRU replacement—replace the following FRUs in the order shown: 1. Fuser drive assembly. See “Fuser drive assembly removal” on page 4-33. 2. Engine board. See “Engine board removal” on page 4-29.	Replace the fuser drive assembly. See “Fuser drive assembly removal” on page 4-33	Replace the fuser top duct. See “Fuser top duct removal” on page 4-34

156 Error code

Black cartridge drive assembly

The black cartridge drive motor has either failed to lock or has lost lock.

Note: Any time any of the cartridge drive motor assemblies are replaced, perform the **“Motor Detect” on page 3-16.** If this procedure is not performed, error code 168 is displayed.

Step	Actions and questions	Yes	No
1	Check the black cartridge drive motor cable connection to J64 on the engine board. Is the cable installed correctly?	Go to step 2	Install the cable correctly
2	Check the black cartridge drive motor cable connection to the black cartridge drive motor card. Is the cable installed correctly?	Go to step 3	Install the cable correctly
3	Check continuity of the black cartridge drive motor cable. Is there continuity?	Go to step 4	Replace the black cartridge assembly cable
4	Replace the black cartridge drive assembly. Perform the “Motor Detect” on page 3-16. Does this fix the problem?	Problem solved	Go to step 5
5	Replace the engine board. Does this fix the problem?	Problem solved	Call your next level support

157 Error code

Magenta cartridge drive assembly

The magenta cartridge drive motor has either failed to lock or has lost lock.

Note: Any time any of the cartridge drive motor assemblies are replaced, perform the **“Motor Detect”** on **page 3-16**. If this procedure is not performed, error code 168 is displayed.

Step	Actions and questions	Yes	No
1	Check the magenta cartridge drive motor cable connection to J47 on the engine board. Is the cable installed correctly?	Go to step 2	Install the cable correctly
2	Check the magenta cartridge drive motor cable connection to the magenta cartridge drive motor card. Is the cable installed correctly?	Go to step 3	Install the cable correctly
3	Check continuity of the magenta cartridge drive motor cable. Is there continuity?	Go to step 4	Replace the magenta cartridge assembly cable
4	Replace the magenta cartridge drive assembly. Perform “Motor Detect” on page 3-16 . Does this fix the problem?	Problem solved	Go to step 5
5	Replace the engine board. Does this fix the problem?	Problem solved	Call your next level support

158 Error code

Cyan cartridge drive assembly

The cyan cartridge drive motor has either failed to lock or has lost lock.

Note: Any time any of the cartridge drive motor assemblies are replaced, perform the **“Motor Detect” on page 3-16**. If this procedure is not performed, error code 168 is displayed.

Step	Actions and questions	Yes	No
1	Check the cyan cartridge drive motor cable connection to J47 on the engine board. Is the cable installed correctly?	Go to step 2	Install the cable correctly
2	Check the cyan cartridge drive motor cable connection to the cyan cartridge drive motor card. Is the cable installed correctly?	Go go step 3	Install the cable correctly
3	Check continuity of the cyan cartridge drive motor cable. Is there continuity?	Go to step 4	Replace the cyan cartridge assembly cable
4	Replace the cyan cartridge drive assembly. Perform “Motor Detect” on page 3-16 . Does this fix the problem?	Problem solved	Go to step 5
5	Replace the engine board. Does this fix the problem?	Problem solved	Call your next level support

159 Error code

Yellow cartridge drive assembly

The yellow cartridge drive motor has either failed to lock or has lost lock.

Note: Any time any of the cartridge drive motor assemblies are replaced, perform the **“Motor Detect” on page 3-16**. If this procedure is not performed, error code 168 is displayed.

Step	Actions and questions	Yes	No
1	Check the yellow cartridge drive motor cable connection to J47 on the engine board. Is the cable installed correctly?	Go to step 2	Install the cable correctly
2	Check the yellow cartridge drive motor cable connection to the yellow cartridge drive motor card. Is the cable installed correctly?	Go to step 3	Install the cable correctly
3	Check continuity of the yellow cartridge drive motor cable. Is there continuity?	Go to step 4	Replace the yellow cartridge assembly cable
4	Replace the yellow cartridge drive assembly. Perform the “Motor Detect” on page 3-16 . Does this fix the problem?	Problem solved	Go to step 5

Step	Actions and questions	Yes	No
5	Replace the engine board. Does this fix the problem?	Problem solved	Call your next level support

160 Error code

Step	Action and questions	Yes	No
1	An incorrect motor has been detected. Replace the ITU drive motor. See “ITU drive motor removal” on page 4-38 . Note: Anytime the ITU drive motor or ITU drive motor assembly is replaced, perform the “Motor Detect” on page 3-16 . Is error code 160 still shown?	Call your next level support	Problem solved

161 Error code

Step	Action and questions	Yes	No
1	Fuser drive motor assembly—error code 161 indicates that an incorrect motor is detected. Replace the fuser drive assembly. See “Fuser drive assembly removal” on page 4-33 . Note: Anytime the fuser drive assembly is replaced, perform the “Motor Detect” on page 3-16 . Does error code 161 continue?	Call your next level support	Problem solved

162 Error code

Black cartridge drive assembly

An incorrect motor is detected.

Note: Any time any of the cartridge drive motor assemblies are replaced, perform the **“Motor Detect” on page 3-16**. If this procedure is not performed, error code 168 is displayed.

Step	Actions and questions	Yes	No
1	Replace the black cartridge drive assembly. See “Cartridge drive assembly removal” on page 4-26 . Perform the “Motor Detect” on page 3-16 . Does the printer display error code 162?	Go to step 2	Problem solved
2	Reflash the NVRAM on the engine board. Does error code 162 continue?	Call your next level support	Problem solved

163 Error code

Magenta cartridge drive assembly

Note: Any time any of the cartridge drive motor assemblies are replaced, perform the **“Motor Detect” on page 3-16**. If this procedure is not performed, error code 168 is displayed

Step	Actions and questions	Yes	No
1	Magenta cartridge drive assembly—error code 163 indicates that an incorrect motor is detected. Replace the magenta cartridge drive assembly. See “Cartridge drive assembly removal” on page 4-26 . Perform the “Motor Detect” on page 3-16 . Does the printer display error code 163?	Go to step 2	Problem solved
2	Reflash the NVRAM on the engine board. Does error code 163 continue?	Call your next level support	Problem solved

164 Error code

Cyan cartridge drive assembly

An incorrect motor is detected.

Note: Any time any of the cartridge drive motor assemblies are replaced, perform the **“Motor Detect” on page 3-16**. If this procedure is not performed, error code 168 is displayed.

Step	Actions and questions	Yes	No
1	Replace the cyan cartridge drive assembly. See “Cartridge drive assembly removal” on page 4-26 . Perform the “Motor Detect” on page 3-16 . Does the printer display error code 164?	Go to step 2	Problem solved
2	Reflash the NVRAM on the engine board. Does error code 164 continue?	Call your next level support	Problem solved

165 Error code

Yellow cartridge drive assembly

An incorrect motor is detected.

Note: Any time any of the cartridge drive motor assemblies are replaced, perform the **“Motor Detect” on page 3-16**. If this procedure is not performed, error code 168 is displayed.

Step	Actions and questions	Yes	No
1	Replace the yellow cartridge drive assembly. See “Cartridge drive assembly removal” on page 4-26 . Perform the “Motor Detect” on page 3-16 . Does the printer display error code 165?	Go to step 2	Problem solved
2	Reflash the NVRAM on the engine board. Does error code 165 continue?	Call your next level support	Problem solved

200 Paper jam—Tray 1

1. Obtain the sub error code from the operator panel.
Press and hold **Return** and press **Select** to view the sub error code.
2. Compare the sub error code to the list below and go to the appropriate service check.

Sub error code	Service check
2D 1B 2D 1C	“S2 or narrow media sensor obstructed” on page 2-67
2D 11 2D 03	“S2 sensor late” on page 2-68
2D 0F 2D 02 2D 05	“S2 or narrow media sensor made early” on page 2-68
2D 04 2D 06	“S2 or narrow media sensor did not break in time” on page 2-69

S2 or narrow media sensor obstructed

- 2D 1B—S2 sensor obstructed
- 2D 1C—Narrow media sensor obstructed

Note: See **“Printer sensors” on page 5-3.**

Step	Action and questions	Yes	No
1	Is sensor flag obstructed by paper debris, out of position, or broken?	Clear obstruction and reinstall or replace flag.	Go to step 2
2	Perform the “BASE SENSOR TEST” on page 3-29. Do both sensor pass the test?	Problem solved	Go to step 3
3	Is the inner deflector out of place, causing sensor flag to bind?	Install inner deflector properly.	Go to step 4
4	Are the sensors connectors fully seated?	Go to step 5	Reseat the sensor connector.
5	Are connectors at J68 fully seated on the engine board?	Go to step 6	Reseat the connector on the engine board.
6	Check sensor cables. Are the cables cut or broken?	Replace the cables.	Go to step 7
7	Replace the S2/NMS/XPAR sensor assembly that did not pass the test. Is the problem solved?	Problem solved	Replace the engine board. See “Engine board removal” on page 4-29.

S2 sensor late

- 2D 11—S2 sensor late
- 2D 03—S2 sensor late

Note: See **“Printer sensors” on page 5-3.**

Step	Action and questions	Yes	No
1	Check the tray for proper edge guide setting and media loading. Edge guides should be adjusted against edge of media. Media should be fanned and lay flat in the tray. Is the media properly loaded in the tray?	Go to step 2	Properly load media.
2	Check the pick tires for contamination or wear. Are pick tires worn or contaminated?	Replace the pick tires. See “Pick rolls” on page 4-48.	Go to step 3
3	Check for obstructions in the paper path. Is the paper path obstructed?	Clear the obstruction.	Go to step 4
4	Is the inner deflector out of position?	Correct the deflector position.	Go to step 5
5	Is the autocompensator damaged or defective?	Go to “Autocompensator service check” on page 2-114	Go to step 6
6	Perform the “BASE SENSOR TEST” on page 3-29 on the S2 sensor. Does the S2 sensor pass the test?	Call your next level of support.	See “S2 or narrow media sensor obstructed” on page 2-67.

S2 or narrow media sensor made early

- 2D 0F—S2 sensor early
- 2D 02—S2 sensor early
- 2D 05—Narrow media sensor early

Note: See **“Printer sensors” on page 5-3.**

Step	Action and questions	Yes	No
1	Check tray for the edge guide setting and media loading. Edge guides should be adjusted against edge of media. Media should be fanned and lay flat in the tray. Is the media properly loaded in the tray?	Go to step 2	Properly load media.
2	Media may not have been cleared from a previous jam. Is media in paper path?	Clear the paper path.	Call your next level of support

S2 or narrow media sensor did not break in time

- 2D 04—S2 sensor did not break in time
- 2D 06—Narrow media sensor did not break in time

Note: See **“Printer sensors” on page 5-3.**

Step	Action and questions	Yes	No
1	Make sure the media installed in the tray meets specifications. Does the media meet specifications?	Go to step 2	Inform the customer that media loaded in Tray x does not meet specification
2	Check tray for the edge guide setting and media loading. Edge guides should be adjusted against edge of media. Media should be fanned and lay flat in the tray. Is the media properly loaded in the tray?	Go to step 3	Properly load media.
3	Remove the ITU and check for the jam at the second transfer roll. Is paper jammed at the second transfer roll?	Clear the jam.	Call your next level of support.

200 Paper jam—Options and envelope feeder

500-sheet option or envelope option

Step	Action and questions	Yes	No
1	Does media feed correctly from Tray 1?	Go to step 2	Go to “200 Paper jam—Tray 1” on page 2-67.
2	Check tray 2 or the envelope feeder, if installed, for proper media loading. Media should be fanned before loading and must lay flat in the tray. Is the media loaded properly?	Go to step 3	Load media properly.
3	Check tray 1 pass thru for damage or obstructions. Note: Remove the paper drawer to inspect tray 1 pass thru. Is the pass thru damaged or obstructed?	Remove obstruction or replace damaged parts.	Go to step 4
4	Remove duplex and check the pass thru. <ul style="list-style-type: none"> • Check the alignment pin on top of the 500-sheet option or envelope feeder, if installed. • Check the pass thru roller drive system on top of tray 2 or envelope feeder, if installed. • Check the pass thru roller drive system on the bottom of the duplex option. 	Problem solved?	Replace the duplex option, 500-sheet option, or the envelope feeder, if installed, as needed.

Multipurpose feeder (MPF)

Step	Action and questions	Yes	No
1	Does the media feed correctly from tray 1?	Go to step 2	Go to “200 Paper jam—Tray 1” on page 2-67.
2	Verify that the media is loaded properly in the multipurpose feeder. Is the media properly loaded?	Replace the friction buckler. See “Friction buckler removal” on page 4-30.	Properly load the media.

Duplex option

Step	Action and questions	Yes	No
1	Does the media feed correctly from tray 1?	Go to step 2	Go to “200 Paper jam—Tray 1” on page 2-67.
2	Does the media feed correctly from the 500-sheet option or the envelope feeder, if installed?	Go to step 3	Go to “500-sheet option or envelope option” on page 2-69.
3	Check tray 1 pass thru for damage or obstruction. Is the pass thru obstructed or damaged?	Clear the obstruction.	Repair or replace the duplex option.

High-capacity input tray (HCIT)

Step	Action and questions	Yes	No
1	Make sure the media installed in the tray meets specifications. Note: The HCIT only supports paper. Does the media meet specifications?	Go to step 2	Inform customer that media does not meet specifications.
2	Does the media feed correctly from tray 1?	Go to step 3	Go to “200 Paper jam—Tray 1” on page 2-67.
3	Does the media feed correctly from the 500-sheet options or envelope feeder, if installed?	Go to step 4	Go to “500-sheet option or envelope option” on page 2-69.
4	Check the pass thru in 500-sheet option or envelope feeder for damage or obstruction, if installed. Is the pass thru obstructed or damaged?	Clear the obstruction.	Repair or replace the HCIT.

201 Paper jam

Step	Action and questions	Yes	No
1	Remove fuser from printer, remove oiler housing from fuser, and pivot the paper guide up. Is paper jammed inside the fuser?	Clear the jam.	Go to step 2
2	Check fuser entry guide for toner buildup. Is toner built up on the fuser entry guide?	Replace the fuser. See “Fuser assembly removal” on page 4-31.	Go to step 3
3	Check fuser exit sensor flag. Does the flag rotate freely and return to normal position when released?	Go to step 4	Replace the fuser. See “Fuser assembly removal” on page 4-31.
4	Reinstall fuser and perform the “BASE SENSOR TEST” on page 3-29. Note: Use a spring hook to actuate the flag. Does fuser exit sensor pass test?	Go to step 5	Perform the following in order: 1. Reseat the connector J10 on the engine board. 2. Replace the fuser. See “Fuser assembly removal” on page 4-31. 3. Replace the LVPS. See “Low voltage power supply (LVPS) removal” on page 4-38. 4. Replace the engine board. See “Engine board removal” on page 4-29.
5	Check the vacuum transport belts (VTB) for motion. Observe the belt through the front door. Are the belts on the VTB assembly turning?	Go to step 6	Go to “Vacuum transport belt (VTB) removal” on page 4-82 to verify correct installation.
6	Check the VTBs for wear or damage. Are the belts worn or damaged?	Replace the VTB. See “Vacuum transport belt (VTB) removal” on page 4-82.	Go to step 7.
7	Check the VTB plate for a buildup of debris. Is there a debris buildup?	Clean off the VTB plate.	Go to step 8
8	Does media move smoothly into the fuser from the VTB?	Call the next level of support.	Replace the “Vacuum transport belt (VTB) fan” on page 4-73.

201 Paper jam**Unable to clear the message**

Step	Action and questions	Yes	No
1	Check the paper path near the fuser transfer plate, the vacuum transport assembly or input to the fuser assembly for obstructions such as pieces of media that may be jammed. Are there any pieces of media jammed?	Remove the obstruction	Go to step 2
2	Check the vacuum transport assembly to make sure the belts are moving. Are the vacuum transport belts moving during printing? Note: You can observe the belts through the front paper jam door.	Go to step 3	Go to step 5
3	Remove all the print cartridges. Remove the vacuum transport assembly and check for pieces of media in the belts. Are there any signs of media in the belts?	Remove the media from the belts	Go to step 4
4	Check for torn belts, excessive toner buildup, or damage to the transport assembly especially to the transport drive gear. Are there broken or damaged parts in the vacuum transport assembly?	Replace the vacuum transport assembly	Go to step 5
5	Make sure that the vacuum transport assembly drive gear meshes correctly with drive gear on the fuser drive assembly. Do the gears mesh correctly?	Go to step 6	Make sure both the fuser drive assembly and vacuum transport assembly are installed correctly.
6	Make sure that the fuser drive assembly drive gear to the vacuum transport is operating correctly. Is the fuser drive assembly drive gear to the vacuum transport operating correctly?	Go to step 7	Replace the fuser drive assembly. See “Fuser drive assembly removal” on page 4-33 .
7	See if the paper is laying flat on the vacuum transport belts. Is the paper laying flat on the vacuum transport belts as it passes through the printer?	Contact your next level support	Replace the vacuum transport assembly

202 Paper jam

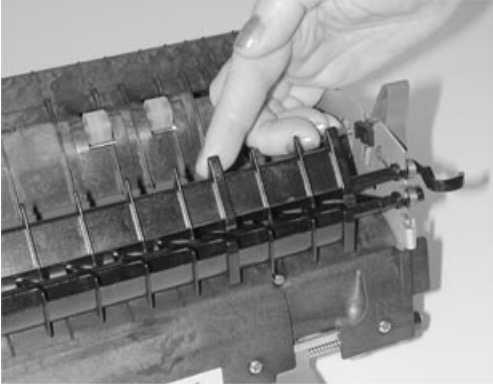
Step	Action and questions	Yes	No
1	Remove the fuser from the printer. Remove the oiler housing from the fuser, and pivot the paper guide up. Is media jammed inside the fuser?	Clear the jam from the fuser.	Go to step 2
2	Check fuser exit sensor flag. Does flag rotate freely and return to normal position when released?	Go to step 3	Replace the fuser. See "Fuser assembly removal" on page 4-31.
3	Check that the diverter gates in the fuser rotate freely.  Do the diverter gates rotate freely?	Go to step 4	Replace the fuser. See "Fuser assembly removal" on page 4-31.
4	Reinstall the fuser and perform the "BASE SENSOR TEST" on page 3-29 for the fuser exit sensor. Note: Use a spring hook to actuate the flag. Does the fuser exit sensor pass?	Go to step 5	Perform the following in order: <ol style="list-style-type: none"> 1. Reseat the connector J10 on the engine board. 2. Replace the fuser. See "Fuser assembly removal" on page 4-31. 3. Replace the LVPS. See "Low voltage power supply (LVPS) removal" on page 4-38. 4. Replace the engine board. See "Engine board removal" on page 4-29.
5	Check that the duplex diverter rotates freely with the redrive door closed. Does the duplex diverter rotate freely?	Go to step 6	Replace the redrive door. See "Redrive door removal" on page 4-14.

Step	Action and questions	Yes	No
6	Check for the proper operation of the redrive. Are both belts in good condition and properly installed?	Go to step 7	Install or replace the redrive assembly. See “Redrive assembly removal” on page 4-68.
7	If the duplex option is in use, check the lower right door paper path. Does media pass freely between the door and the metal plate?	Go to step 8	Replace the lower right door assembly. See “Lower right door assembly removal” on page 4-12.
8	If the duplex option is in use, remove the duplex R.H. access panel to check if the jam occurred at duplex entry edge guide. Did the jam occur at the duplex entry edge guide?	Replace the duplex option.	Go to step 9
9	If the duplex option is in use, check the actuator button. See “Duplex option deflector button replacement” on page -29. Should the actuator button be replaced?	Replace the button.	Go to step 10
10	If the finisher option is in use, refer to the finisher manual for the alignment procedure. Is the finisher properly aligned?	Go to step 11	Realign the finisher.
11	Is a 5-bin mailbox option or an output expander option in use?	Check the following: <ul style="list-style-type: none"> • Reseat the option on the printer. • Verify the printer top cover is properly seated. 	Call your next level of support.

Output expander

A sheet of paper is jammed prior to the pass thru sensor flag or a sheet of paper feeds out to the standard bin even though bin *x* is selected. Paper exits half way out of the redrive.

Note: For this type of problem check the **“Sub error code table” on page 2-17**. They can help isolate the problem. 202 Paper Jam messages can also occur prior to the output expander pass thru sensor.

Step	Actions and questions	Yes	No
1	Check of mechanical drive components: <ul style="list-style-type: none"> • Check the output expander drive belt to make sure it is installed on the drive pulley and belt idler pulley. • Check the belt tension spring to make sure it is not loose or broken. Are there any problems with these parts?	Repair or replace as necessary	Go to step 2
2	Check of mechanical linkage/DC motor drive assembly: <ul style="list-style-type: none"> • Check to see if the DC motor is functioning properly. • Check the gears, clutch and other linkage parts for correct operation and wear, broken teeth, or damaged parts. Are there any problems with these parts?	Replace the mechanical linkage/DC motor drive assembly	Call your next level support

230 Paper jam

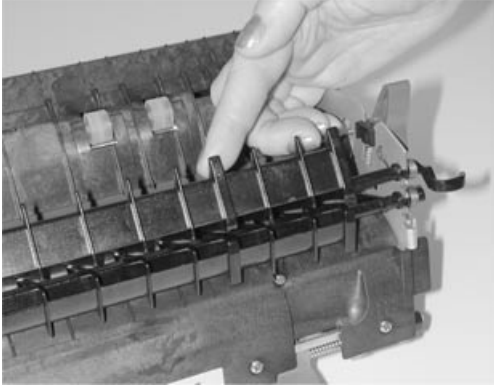
Step	Action and questions	Yes	No
1	Thoroughly examine the duplex paper path for torn paper that may be blocking the sensors or paper path. Is the duplex paper path clear?	Go to step 2	Clear the paper path.
2	Check the lower right door paper path. Does media pass freely between the door and the metal plate?	Go to step 3	Replace the lower right door. See “Lower right door assembly removal” on page 4-12.
3	Are any of the following conditions true? <ul style="list-style-type: none"> • Only the back of the page of a duplex job prints and exits into the standard bin. • Media exits the right side of the print. • Media jams in the duplex at the diverter. 	Go to step 4	Go to step 8
4	Open the redrive door and check that the diverter operates freely. Does the diverter operate freely?	Go to step 5	Replace the fuser assembly. See “Fuser assembly removal” on page 4-31.
5	Close the redrive door and check that the diverter operates freely.  Does the diverter operate freely?	Go to step 6	Replace the redrive door. See “Redrive door removal” on page 4-14.
6	Check that the diverter actuator link is not binding or damaged. Examine the link for damage under the duplex option. Is link binding or damaged?	Repair the actuator link.	Go to step 7
7	Check the duplex actuator button. See “Duplex option deflector button replacement” on appendix page A-29. Should the button be replaced?	Replace the Actuator button.	Go to step 8
8	Paper input and paper exit systems. Check for correct operation by performing the duplex “Sensor Test” on page 3-23. Do the sensors pass the test?	Repair or replace the duplex option.	Go to step 9

Step	Action and questions	Yes	No
9	Make sure the sensors are correctly connected to the duplex system board. Are the cables correctly connected?	Repair or replace the duplex option.	Correctly connect the cables.

24x Paper jam

Printer configuration and 24x paper jam codes

Paper jam code	Tray identification	Problem related to the following option or tray (depending on installed configuration)
241	Tray 1	Internal 500-sheet tray
242	Tray 2	500-sheet tray option
243	Tray 3	500-sheet tray option or 2000-sheet HCIT option
244	Tray 4	500-sheet tray option

A maximum of three optional 500-sheet tray options can be installed or a maximum of one 500-sheet tray option plus a 2000-sheet HCIT option is supported. If a 2000-sheet HCIT is installed, and optional 500-sheet tray is required and must be installed under the duplex option.

See **“Printer configuration diagrams for 24x paper jams”** on page 2-81.

500-sheet drawer option (242, 243, 244)

Media does not reach the pass thru sensor.

Warning: Whenever the 500-sheet tray is removed, use care as the autocompensator may be in its down position which could result in damage to the autocompensator assembly.

The tray empty sensor, paper low sensor, and pass thru sensor for any installed Tray x (x=1 through 4) can be checked using the **“Sensor Test”** on page 3-24.

Step	Action and questions	Yes	No
1	Is tray x a HCIT 2000-sheet option?	Go to step 2	Go to step 3
2	Is a 24x paper jam error message displayed?	Go to “2000-Sheet high-capacity input tray (HCIT) (243, 244)” on page 2-79.	Go to “High-capacity input tray (HCIT) 2000-sheet option service check” on page 2-128.
3	Make sure the media installed in the tray meets specifications. Does the media meet specifications?	Go to step 4	Inform the customer that media loaded in Tray x does not meet specification
4	Make sure the media is loaded correctly. Make sure the side and back restraints are located and seated properly. Is the media loaded correctly?	Go to step 5	Load the media correctly

Step	Action and questions	Yes	No
5	See if the paper is trying to feed from the tray. Note: You can observe the autocompensator feed rolls and the paper through the tray access door. Run the Tray x feed test from the Diagnostics Menu to help diagnose a feed problem. See "Feed Test" on page 3-24. Is the media leaving the tray?	Go to step 9	Go to step 6
6	Are the autocompensator pick arm rolls turning?	Go to step 7	Go to step 11
7	Check the autocompensator pick arm rolls for wear or contamination. Are the autocompensator pick arm rolls worn or contaminated?	Replace the Pick Arm Rolls. See "Pick rolls" on page 4-48. Replace both rolls at the same time.	Go to step 8
8	Check paper tray wear strips for wear or contamination. Are the wear strips worn or contaminated?	Replace the wear strips	Go to step 9
9	Check the pass thru sensor for correct operation by running the Tray x sensor test from the Diagnostics Menu. See "Sensor Test" on page 3-24. Does the pass thru sensor operate correctly?	Check for any obstructions that might catch the media and create a paper jam	Go to step 10
10	Make sure the pass thru sensor is correctly connected to the Tray x system board. Is the sensor cable connected correctly?	Replace the FRUs in the following order: 1. Pass thru sensor assembly 2. Electronics/size sensing assembly.	Install the cable correctly
11	Check the autocompensator cable for correct installation to Tray x system board. Is the cable connected correctly?	Go to step 12	Install the cable correctly
12	Check the base door assembly, paper guide, wall support plate and door spring for damaged parts, warped parts or obstructions that might cause the paper to jam over the pass thru sensor. Did you find any problems with these parts?	Repair or replace parts as necessary	Replace the autocompensator assembly. See "Autocompensator pick assembly removal" on page 4-17.

2000-Sheet high-capacity input tray (HCIT) (243, 244)

Use the **“HCIT Standalone Test Mode”** on page 3-34 inside the HCIT to help isolate paper jams. Run the Standalone Feeding Operation to observe paper feeding from the tray and through the feed assembly. Use the **“HCIT system board LED error code table”** on page 2-128 to further isolate paper jam or sensor problem.

Before proceeding with this service check make sure the HCIT is installed correctly.

Step	Action and questions	Yes	No
1	Check for pieces of paper or other obstructions in the feed assembly. Are any pieces of paper or obstructions in the feed assembly?	Remove any paper or obstructions	Go to step 2
2	Make sure the media loaded in the paper tray meets printer supplies specifications. Does the media meet specifications?	Go to step 3	Inform the customer that media in the paper tray does not meet specifications
3	Use the standalone feeding operation to observe paper feeding from the tray. Does the paper feed from the paper tray?	Go to step 14	Go to step 4
4	Using the standalone feeding operation test, observe the registration motor (the registration motor is the motor at the top of the feed assembly). Does the motor turn?	Go to step 5	Go to step 6
5	Does the pick motor, the lower motor in the feed unit assembly, turn?	Go to step 8	Go to step 7
6	Check the registration motor cable to HCIT system board cable connected to CN3 for correct installation. Is the cable connected correctly?	Replace the following FRUs in the order shown: 1. HCIT system board 2. Feed unit assembly	Install the cable correctly.
7	Check the pick motor cable to HCIT system board cable connected to CN4 for correct installation. Is the cable connected correctly?	Replace the following FRUs in the order shown: 1. HCIT system board 2. Feed unit assembly	Install the cable correctly.
8	Use the “HCIT system board LED error code table” on page 2-128. Does the LED flash 7 times?	Go to step 9	Go to step 11
9	Make sure the registration home sensor cable is installed correctly to the sensor and to CN6 on the system board. Is the cable connected correctly?	Go to step 10	Install the cable correctly.

Step	Action and questions	Yes	No
10	Is the registration home sensor operating correctly?	Replace the following FRUs in the order shown: 1. HCIT system board 2. Feed unit assembly	Replace the following FRUs in the order shown: 1. Registration sensor 2. HCIT system board
11	Use the “HCIT system board LED error code table” on page 2-128. Does the LED flash 8 times?	Go to step 12	Go to step 14
12	Make sure the pick home sensor cable is installed correctly to the sensor and to CN6 on the system board. Is the cable connected correctly?	Go to step 13	Install the cable correctly.
13	Is the registration home sensor operating correctly?	Replace the following FRUs in the order shown: 1. HCIT system board 2. Feed unit assembly	Replace the following FRUs in the order shown: 1. Registration sensor 2. HCIT system board
14	Use the standalone feeding operation test to determine where the paper jams. Use the “HCIT system board LED error code table” on page 2-128 to help isolate problems in the feed unit assembly. Are you able to determine where the failure is occurring?	Repair or replace parts as necessary.	Replace the feed unit assembly.

Printer configuration diagrams for 24x paper jams

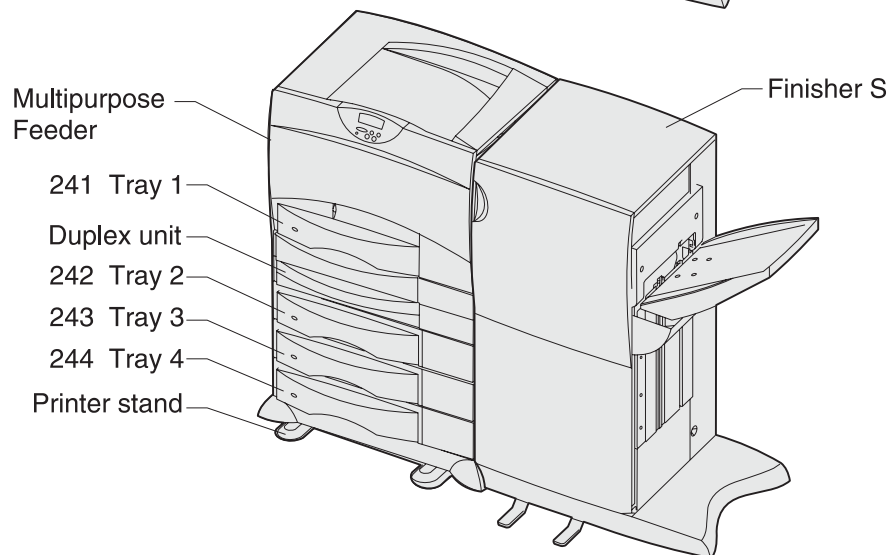
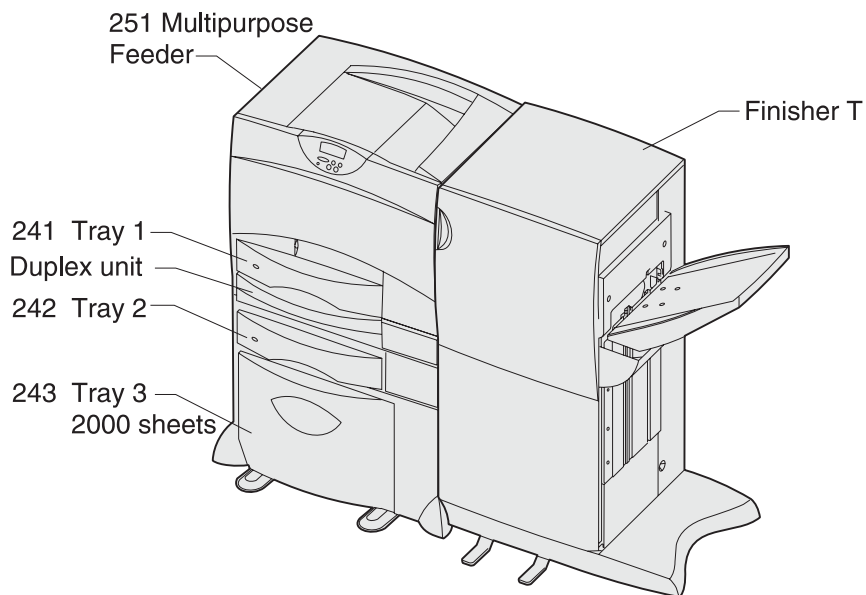
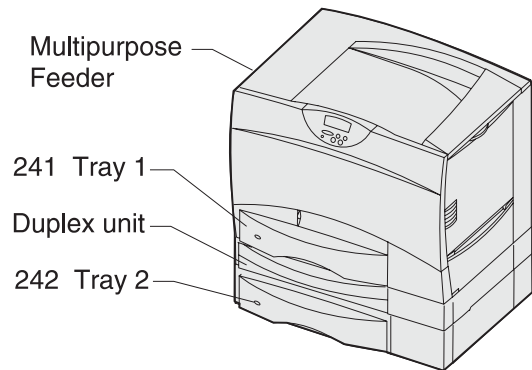
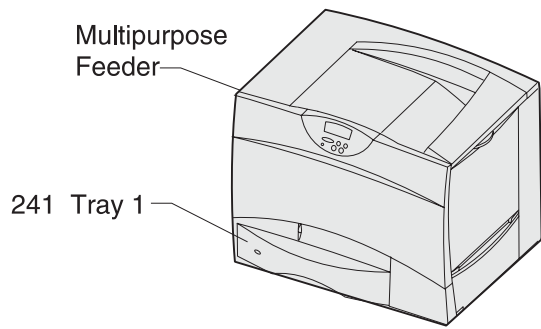

250 Paper jam**Unable to clear the message—multipurpose feeder loaded.**

Step	Action and questions	Yes	No
1	Make sure the media in the MPF meets specifications. Does the media meet specifications?	Go to step 2	Inform user that the media in the MPF does not meet specifications.
2	Does the media feed correctly from tray 1?	Go to step 3	Go to “Tray 1 service check” on page 2-149.
3	Is the Paper Type setting correct for media in the MPF?	Go to step 4	Correct the Paper Type setting.
4	Check the media is loaded properly. The side restraint should not be too tight. The leading edge of the media should be sitting on the friction buckler. Is the media correctly loaded?	Go to step 5	Properly load the media.
5	Open the MPF to the horizontal position and check the paper path for obstructions. Is the paper path obstructed?	Clear the obstruction	Go to step 6
6	Raise the pick roll off the media and test the MPF. Does the pick roll turn?	Go to step 8	Go to step 7
7	Open the lower jam access door, move the MPF bracket assembly gear to the lowest position and test the MPF. Does the MPF bracket assembly rise and engage the gear?	Go to step 8	Replace the MPF bracket assembly. See “MPF bracket assembly” on page 7-21.
8	Does media jam on the friction buckler?	Replace the friction buckler. See “Friction buckler” on page 4-31.	Call your next level of support.

Multipurpose feeder (MPF)—no media in MPF

A 250 Paper Jam indicates that the MPF tried to feed a sheet of media from the MPF tray. A 250 Paper Jam may occur when there is no paper in the MPF, MPF is selected as the paper source, or the MFP sensor is malfunctioning. If media is in the MFP it may feed normally with no 250 Paper Jam even though the sensor is malfunctioning.

Step	Action and questions	Yes	No										
1	Enter the Diagnostics Menu. Select Input Tray Tests , Sensor Test , and Multipurpose Feeder . Manually actuate the MP sensor by moving the paper flag in the MPF. Does the test pass?	Replace the MPF assembly. See “Multipurpose feeder (MPF) removal” on page 4-40.	Go to step 2										
2	Make sure that the MPF sensor cable from the engine board is correctly installed at J70 on the engine board. Is the cable correctly installed?	Go to step 3	Install the cable correctly										
3	Check the cable connection between the MP sensor cable and the sensor. Is the connection good between the two cables?	Go to step 4	Install the cable correctly										
4	Disconnect the sensor cable from J70 on the engine board. Measure the following voltages on J70, being careful not to short any adjacent pins in the connector. All voltages are approximate values. <table border="1" data-bbox="418 1003 688 1178"> <thead> <tr> <th>Connector pin</th> <th>Voltage</th> </tr> </thead> <tbody> <tr> <td>J70-1</td> <td>+5 V dc</td> </tr> <tr> <td>J70-2</td> <td>+5 V dc</td> </tr> <tr> <td>J70-3</td> <td>+5 V dc</td> </tr> <tr> <td>J70-4</td> <td>0 V dc</td> </tr> </tbody> </table> Are the voltages correct?	Connector pin	Voltage	J70-1	+5 V dc	J70-2	+5 V dc	J70-3	+5 V dc	J70-4	0 V dc	Go to step 5	Replace the engine board. See “Engine board removal” on page 4-29.
Connector pin	Voltage												
J70-1	+5 V dc												
J70-2	+5 V dc												
J70-3	+5 V dc												
J70-4	0 V dc												
5	Check continuity of the sensor cable that is between the engine board and MPF assembly. Is there continuity?	Replace the sensor assembly.	Replace the sensor cable assembly.										

271 Paper jam - Check Bin 1**Output expander—POST incomplete.**

Step	Actions and questions	Yes	No
1	Pass thru sensor flag—check the sensor flag for correct operation. Is the flag operating correctly?	Go to step 2	Repair or replace as necessary
2	Pass thru sensor cable—make sure the pass thru sensor cable is correctly connected to J3 on the control board. Is the cable connected correctly?	Go to step 3	Reseat the cable
3	Voltage check—disconnect the pass thru sensor cable from the control board and check the voltage on J3-3. The voltage measures approximately +5 V dc. Is the voltage correct?	Go to step 4	Replace the control board
4	Voltage check—measure the voltage at J3-2. The voltage measures approximately 0 V dc. Is the voltage correct?	Replace the control board	Replace the sensor assembly

Output Expander, POST complete—First sheet of paper feeds into Output Bin 1.

Note: Before proceeding with this service check run the Output Bin x Sensor Test and check for the failing sensor.

Sensor tests:

- XNF Near Full (Upper part of sensor assembly)
- F Full (Lower part of sensor assembly)
- P Pass Thru Sensor

Step	Actions and questions	Yes	No
1	DC motor cable connection—make sure the DC motor connector is correctly installed at J4 on the Output Expander Option board. Is the cable installed correctly?	Go to step 2	Install the cable correctly.
2	DC motor mechanical linkage assembly—check the resistance of the motor on the cable connector. Check the resistance between J4-1 and J4-2. The resistance measures between 115 and 135 ohms. Is the resistance correct?	Go to step 3	Replace the DC motor mechanical linkage assembly.
3	D.C. motor mechanical linkage assembly—check for continuity between J4-1 and J4-2 and the case of the motor. It measures infinity. Is there continuity between J4-1 or J4-2 and the case of the motor? Note: If the motor is shorted from either J4-1 or J4-2 and the case of the motor, it may be necessary to replace the output expander control board.	Replace the DC motor mechanical linkage assembly.	Go to step 4

Step	Actions and questions	Yes	No										
4	<p>Output expander board—disconnect the motor cable from J4 and check the voltages at J4 on the board.</p> <p>Note: All voltages are approximate values:</p> <table border="1"> <thead> <tr> <th>Connector pin</th> <th>Voltage, motor idle</th> </tr> </thead> <tbody> <tr> <td>J4-1</td> <td>+24 V dc</td> </tr> <tr> <td>J4-2</td> <td>+24 V dc</td> </tr> <tr> <td>J4-5</td> <td>+5 V dc</td> </tr> <tr> <td>J4-6</td> <td>+5 V dc</td> </tr> </tbody> </table> <p>Warning: Be careful not to short to adjacent pins on the connector.</p> <p>Are the voltages correct?</p>	Connector pin	Voltage, motor idle	J4-1	+24 V dc	J4-2	+24 V dc	J4-5	+5 V dc	J4-6	+5 V dc	Replace the DC motor mechanical linkage assembly.	Replace the output expander control board.
Connector pin	Voltage, motor idle												
J4-1	+24 V dc												
J4-2	+24 V dc												
J4-5	+5 V dc												
J4-6	+5 V dc												

272 Paper jam - Check Bin x

5-Bin mailbox—POST complete

Step	Action and questions	Yes	No
1	<p>Bottom pass thru sensor flag—make sure the flag is operating correctly and is not binding, broken, and there is no interference from the sensor cable.</p> <p>Is there any problem found with the sensor flag?</p>	Fix or replace the flag.	Go to step 2
2	<p>Bottom pass thru sensor—make sure the sensor is correctly connected to J5 on the control board.</p> <p>Is the sensor connected correctly?</p>	Go to step 3	Reseat the cable.
3	<p>Bottom pass thru sensor voltage check 1—disconnect the pass thru sensor cable and check the voltage at J5-3 on the board. The voltage measures approximately +5 V dc.</p> <p>Is the voltage correct?</p>	Go to step 4	Replace the control board.
4	<p>Bottom pass thru sensor voltage check 2—check the voltage at J5-2 on the board, the voltage measures approximately 0 V dc.</p> <p>Is the voltage correct?</p>	Replace the sensor assembly.	Replace the control board.

5-Bin mailbox—POST incomplete

Step	Action and questions	Yes	No
1	<p>Pass thru sensor flag—check the sensor flag for correct operation.</p> <p>Is the flag operating correctly?</p>	Go to step 2	Repair or replace as necessary.
2	<p>Pass thru sensor cable—make sure the pass thru sensor cable is correctly connected to J3 on the control board.</p> <p>Is the sensor connected correctly?</p>	Go to step 3	Reseat the cable.

Step	Action and questions	Yes	No
3	Voltage check—Disconnect the pass thru sensor cable from the control board and check the voltage on J3-3. The voltage measures approximately +5 V dc. Is the voltage correct?	Go to step 4	Replace the control board.
4	Voltage check—Measure the voltage at J3-2. The voltage measures approximately 0 V dc. Is the voltage correct?	Replace the control board.	Replace the sensor assembly.

274 Paper jam - Check Bin 4

5-Bin mailbox

Note: When a 274 Paper Jam Check Bin 4 message appears, a problem exists with the top pass thru sensor

Note: assembly or the control board.

Step	Action and questions	Yes	No
1	Top pass thru sensor flag—check the top sensor flag for correct operation, binding, broken parts or interference from the sensor cable. Are there any problem with the sensor flag?	Repair as necessary	Go to step 2
2	Top pass thru sensor—make sure the top pass thru sensor is correctly connected to J11 on the control board. Is the sensor connected correctly?	Go to step 3	Reseat the cable
3	Top pass thru sensor voltage check 1—disconnect the top pass thru sensor at J11 and check the voltage at J11-3. The voltage measures approximately +5 V dc. Is the voltage correct?	Go to step 4	Replace the control board
4	Top pass thru sensor voltage check 2—check the voltage at J11-2, the voltage should measure approximately 0 V dc. Is the voltage correct?	Replace the sensor assembly	Replace the control board

280 Paper jam

Use the table below to determine where to check for jams in the printer and to diagnose a 280 Paper Jam. Check the area indicated to find the jam and the problem. If this does not fix the problem, contact the next level of support.

Press **Menu** to scroll down to see the additional display lines and view the value at the indicated position (data bit 1 - DB1) and match the information to the table below.

Finisher (Bin 1) - No other output options

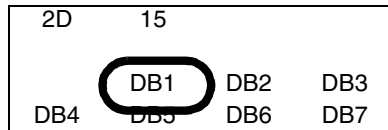

Finisher (Bin 2) - With output expander installed

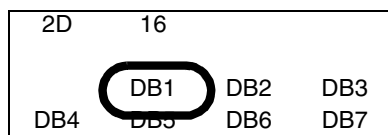

Finisher (Bin 6) - With 5-bin mailbox installed

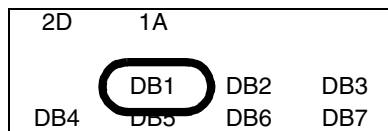

DB1	Explanation
01	Paper detected at inverter timing sensor too long. Paper jam in inverter, sensor failure.
02	Paper detected at inverter jam sensor too long. Paper jam in inverter, sensor failure.
03	Paper detected at drop timing sensor too long. Paper jam at accumulator entrance, sensor failure.
04	Paper detected at exit timing sensor too long. Paper jam at exit, chad stuck in sensor, sensor failure.
06	Punch motor homing timeout error. Backup chads jamming motor, motor or sensor failure.
07	Stapler jam detected. Too many sheets or stiff paper in accumulator, motor or sensor failure.
08	Belt motor homing timeout error. Paper jam in accumulator, motor or sensor failure.
09	Tray elevation motor timeout error. Stuck or failed paper level sensor, motor failure.
13	Paper not detected at inverter timing sensor within timeout. Jam near input, misdirected sheet (diverter stuck or misaligned), sensor failure.
14	Paper not detected at inverter jam sensor within timeout. Paper jam in inverter, sensor failure.
15	Paper not detected at drop timing sensor within timeout. Paper jam in inverter, sensor failure.
16	Paper not detected at exit timing sensor within timeout. Jam in accumulator, belt motor failure, sensor failure.
1B	Paper detected at inverter timing sensor before punch timing sensor. Damaged sheet (dogear), transparency sent to finisher, sensor failure.

DB1	Explanation
1C	Paper detected at punch timing sensor too long. Dirty or failed punch timing sensor.
1E	Paper not detected at punch timing sensor within timeout. Jam near input, misdirected sheet (diverter stuck or misaligned), sensor failure.
1F	Finisher internal software error. Intermittent sensor might cause this error.
20	Unexpected sheet detected at punch timing sensor. Stuck diverter (possibly due to alignment), damaged sheet, dirty or failed sensor.

900 RIP Software Error

There may be a communication problem (bad cable, network connection, and so on), software issue, or a hardware problem with the controller board/INA. The communication and software aspects should be checked first. Determine if the problem is constant or intermittent.

Constant 900 errors

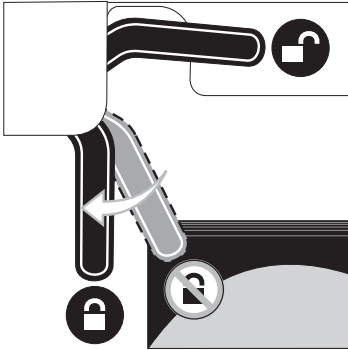
Step	Action and questions	Yes	No
1	<p>Reset the ITU electrical disconnect. Turn the printer off. Raise and lower the lever above the ITU handle. Do not remove the ITU assembly itself. Make sure the level is pressed firmly in place. Turn the printer on.</p>  <p>Does the 900 error display?</p>	Go to step 2	Problem resolved
2	<p>Disconnect the printer from any external connections. Turn the power off and remove any parallel, USB, or network connections. Turn the printer on.</p> <p>Does the 900 error display?</p>	Go to step 4	Go to step 3
3	<p>Run the internal test pages. Print one of the internal test pages from the Utilities Menu. If the printer works correctly while disconnected, have the user or their network administrator verify that there are no jobs in the queue which may be causing the error.</p> <p>Does the error remain?</p>	Inform the user or network administrator of the issue.	Go to step 4
4	<p>Turn the printer off. Remove any options from the RIP or riser card, such as additional memory, hard disk drives, or option cards.</p> <p>Does the 900 error persist when the printer is turned on?</p>	Go to step 5	Determine which option is causing the 900 error.

Step	Action and questions	Yes	No
5	<p>Restore factory defaults from the Configuration Menu.</p> <p>Warning: When factory defaults are restored, all menu items are returned to the factory default values except:</p> <ul style="list-style-type: none"> • Display Language. • All settings in the Parallel Menu, Serial Menu, Network Menu, and USB Menu. <p>All downloaded resources (fonts, macros, and symbol sets) in printer memory (RAM) are deleted. (Resources residing in flash memory or on the hard disk are unaffected.)</p>	<p>Record the secondary error codes. With the 900 Service RIP Error displayed, press Select and Return together. Record the complete list. Press Menu to scroll. The code may be a very long string of characters and numbers, but is needed for analysis.</p> <p>Contact your next level of support.</p>	Problem solved.

Intermittent 900 Service RIP Error codes

Capturing the following information aids in determining the nature of the intermittent error.

1. Crash codes - With the 900 Service RIP Error displayed, press **Select** and **Return** together. Record the complete secondary codes by scrolling with **Menu**. The code may be a very long string of characters and numbers, but it is needed to analyze the problem.
2. Print history - Printed the printer history by entering Diagnostics Mode and selecting **Print History** in the **Development** menu.
3. Code level - Obtain the code level for the RIP, network, and engine. All of these can be found on **Print Menus** page from the **Utilities** menu.
4. Type of connection being used to print - Record the type of connection. For example, direct USB or parallel, or network peer to peer, Ethernet, token ring, or so on.
5. Software application - Does one particular application or print job sent to the printer produce this error?
6. Driver - What driver or driver level.

With this information in hand, contact you next level of support.

900 Error Code displayed when the machine is connected to a network while still in Setup Required Mode

Step	Actions and questions	Yes	No
1	<p>Perform the following steps:</p> <ol style="list-style-type: none"> 1. Power the printer off. 2. Disconnect the printer from the network. 3. Power the printer on and complete the setup process. 4. When setup is complete, power off the printer and reconnect to the network. <p>Is the same 900 Service Error displayed?</p>	Contact your next level support	Problem solved

925 Error code

Fuser fan

Step	Actions and questions	Yes	No																									
1	Turn the power off and manually spin the fan and check that it rotates freely. Does the fan rotate freely?	Go to step 2	Replace the fuser fan. See “Fuser fan removal” on page 4-34																									
2	Check the fuser fan cable connection to the engine board, J2 for correct installation. Is the cable installed correctly?	Go to step 3	Install the cable correctly																									
3	Disconnect the fuser fan from J2 on the engine board and check the voltages on J2. <table border="1" data-bbox="354 680 943 894"> <thead> <tr> <th>Pin</th> <th>Fan on</th> <th>Fan off</th> <th>Fan disconnected Fan switch on</th> <th>Fan disconnected Fan switch off</th> </tr> </thead> <tbody> <tr> <td>J2-1</td> <td>+1.6 V dc</td> <td>+3.3 V dc</td> <td>+3.3 V dc</td> <td>+3.3 V dc</td> </tr> <tr> <td>J2-2</td> <td>0 V</td> <td>0 V</td> <td>0 V</td> <td>0 V</td> </tr> <tr> <td>J2-3</td> <td>+1.9 V dc</td> <td>0 V dc</td> <td>0 V</td> <td>+2 V dc</td> </tr> <tr> <td>J2-4</td> <td>+24 V dc</td> <td>+24 V dc</td> <td>+24 V dc</td> <td>+24 V dc</td> </tr> </tbody> </table> Are the voltages correct?	Pin	Fan on	Fan off	Fan disconnected Fan switch on	Fan disconnected Fan switch off	J2-1	+1.6 V dc	+3.3 V dc	+3.3 V dc	+3.3 V dc	J2-2	0 V	0 V	0 V	0 V	J2-3	+1.9 V dc	0 V dc	0 V	+2 V dc	J2-4	+24 V dc	+24 V dc	+24 V dc	+24 V dc	Replace the fuser fan. See “Fuser fan removal” on page 4-34	Replace the engine board. See “Engine board removal” on page 4-29
Pin	Fan on	Fan off	Fan disconnected Fan switch on	Fan disconnected Fan switch off																								
J2-1	+1.6 V dc	+3.3 V dc	+3.3 V dc	+3.3 V dc																								
J2-2	0 V	0 V	0 V	0 V																								
J2-3	+1.9 V dc	0 V dc	0 V	+2 V dc																								
J2-4	+24 V dc	+24 V dc	+24 V dc	+24 V dc																								

926 Error code

VTB Fan

Note: The VTB fan is turned on during POR and while printing.

Step	Actions and questions	Yes	No
1	Turn the power off and manually spin the fan and check that it rotates freely. Does the fan rotate freely?	Go to step 2	Replace the VTB fan. See “Vacuum transport belt (VTB) fan removal” on page 4-84.
2	Check the VTB fan cable connection to the engine board, J4, for correct installation. Is the cable installed correctly?	Go to step 3	Install the cable correctly.
3	Check for a piece of media or a cable caught in the fan. Is there an obstruction in the fan?	Remove the obstruction.	Go to step 4

Step	Actions and questions	Yes	No																									
4	Disconnect the VTB fan from J4 on the engine board and check the voltages on J4.	Replace the VTB fan. See “Vacuum transport belt (VTB) fan removal” on page 4-84	Replace the engine board. See “Engine board removal” on page 4-29.																									
	<table border="1"> <thead> <tr> <th>Pin</th> <th>Fan on</th> <th>Fan off</th> <th>Fan disconnected Fan switch on</th> <th>Fan disconnected Fan switch off</th> </tr> </thead> <tbody> <tr> <td>J4-1</td> <td>+1.6V dc</td> <td>+3.3 V dc</td> <td>+3.3 V dc</td> <td>+3.3 V dc</td> </tr> <tr> <td>J4-2</td> <td>0 V</td> <td>0 V</td> <td>0 V</td> <td>0 V</td> </tr> <tr> <td>J4-3</td> <td>+3.1 V dc</td> <td>0 V dc</td> <td>0 V</td> <td>+2 V dc</td> </tr> <tr> <td>J4-4</td> <td>+24 V dc</td> <td>+24 V dc</td> <td>+24 V dc</td> <td>+24 V dc</td> </tr> </tbody> </table>			Pin	Fan on	Fan off	Fan disconnected Fan switch on	Fan disconnected Fan switch off	J4-1	+1.6V dc	+3.3 V dc	+3.3 V dc	+3.3 V dc	J4-2	0 V	0 V	0 V	0 V	J4-3	+3.1 V dc	0 V dc	0 V	+2 V dc	J4-4	+24 V dc	+24 V dc	+24 V dc	+24 V dc
	Pin			Fan on	Fan off	Fan disconnected Fan switch on	Fan disconnected Fan switch off																					
	J4-1			+1.6V dc	+3.3 V dc	+3.3 V dc	+3.3 V dc																					
	J4-2			0 V	0 V	0 V	0 V																					
	J4-3			+3.1 V dc	0 V dc	0 V	+2 V dc																					
J4-4	+24 V dc	+24 V dc	+24 V dc	+24 V dc																								
Are the voltages correct?																												

927 Error code

RIP fan

Step	Actions and questions	Yes	No																									
1	Turn the power off and manually spin the fan and check that it rotates freely. Does the fan rotate freely?	Go to step 2	Replace the RIP fan. See “RIP fan removal” on page 4-71.																									
2	Check the RIP fan cable connection to the engine board, J53 for correct installation. Is the cable installed correctly?	Go to step 3	Install the cable correctly.																									
3	Check for any obstruction in the fan. Is there an obstruction in the fan?	Remove the obstruction.	Go to step 4																									
4	Disconnect the RIP fan from J53 on the engine board and check the voltages on J53.	Replace the RIP fan. See “RIP fan removal” on page 4-71.	Replace the engine board. See “Engine board removal” on page 4-29.																									
	<table border="1"> <thead> <tr> <th>Pin</th> <th>Fan on</th> <th>Fan off</th> <th>Fan disconnected Fan switch on</th> <th>Fan disconnected Fan switch off</th> </tr> </thead> <tbody> <tr> <td>J53-1</td> <td>+1.6 V dc</td> <td>+3.3 V dc</td> <td>+3.3 V dc</td> <td>+3.3 V dc</td> </tr> <tr> <td>J53-2</td> <td>0 V</td> <td>0 V</td> <td>0 V</td> <td>0 V</td> </tr> <tr> <td>J53-3</td> <td>+1.9 V dc</td> <td>0 V dc</td> <td>0 V</td> <td>+2 V dc</td> </tr> <tr> <td>J53-4</td> <td>+24 V dc</td> <td>+24 V dc</td> <td>+24 V dc</td> <td>+24 V dc</td> </tr> </tbody> </table>			Pin	Fan on	Fan off	Fan disconnected Fan switch on	Fan disconnected Fan switch off	J53-1	+1.6 V dc	+3.3 V dc	+3.3 V dc	+3.3 V dc	J53-2	0 V	0 V	0 V	0 V	J53-3	+1.9 V dc	0 V dc	0 V	+2 V dc	J53-4	+24 V dc	+24 V dc	+24 V dc	+24 V dc
	Pin			Fan on	Fan off	Fan disconnected Fan switch on	Fan disconnected Fan switch off																					
	J53-1			+1.6 V dc	+3.3 V dc	+3.3 V dc	+3.3 V dc																					
	J53-2			0 V	0 V	0 V	0 V																					
	J53-3			+1.9 V dc	0 V dc	0 V	+2 V dc																					
J53-4	+24 V dc	+24 V dc	+24 V dc	+24 V dc																								
Are the voltages correct?																												

930 Error code**LVPS**

This problem with the fuser circuits is usually the zero crossover signal from the LVPS not working correctly.

Step	Action and questions	Yes	No
1	LVPS cable—check the LVPS cable to J10 on the engine board to make sure it is seated correctly. See “Engine board” on page 5-7. Is the cable seated correctly?	Go to step 2	Install the cable correctly
2	Voltage checks—disconnect J10 from the engine board assembly. Go to “Engine board” on page 5-7. Check the voltage at J10-10, on the cable. It measures approximately +3.7 V dc. Is the voltage correct?	Go to step 3	Replace the following FRUs in order: 1. LVPS. See “Low voltage power supply (LVPS) removal” on page 4-38 2. Engine board. See “Engine board removal” on page 4-29
3	Is error code 930 still displayed?	Replace the LVPS assembly. See “Low voltage power supply (LVPS) removal” on page 4-38	Problem solved

940 Error code

Cyan toner metering cycle (TMC)

Toner metering cycle (TMC) is where the code and electronics in the printer sense an addition of toner in the cartridge developing area. If the printer is expecting a toner addition cycle but one is not detected, a 94x TMC Error is displayed.

Replacement of the cartridge may fix the problem temporarily if the problem is with the printer. Only replace the cartridge if there are no problems with the printer or if the cartridge is known to be defective.

Note: Before proceeding with this service check, observe the error log for repetitive occurrences of a 94x service error.

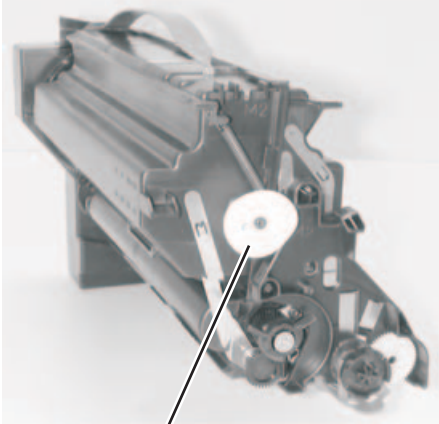
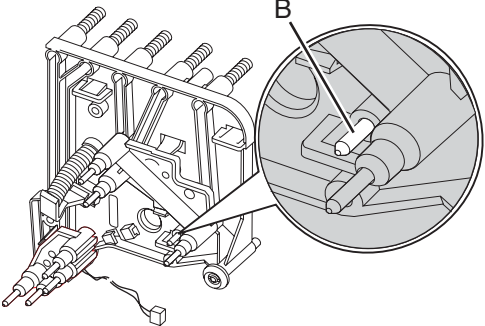
Step	Actions and questions	Yes	No
1	<p>Check the toner metering cam (A) on the rear of the cyan cartridge.</p> <p>Note: In some cartridges the toner metering cam is black.</p>  <p style="text-align: center;">A</p> <p>Is the cam present on the cartridge?</p>	Go to step 2	<p>If the toner metering cam is not present, check the printer to make sure it is not inside.</p> <p>Replace the damaged cartridge.</p>
2	<p>Check the TMC pin (B) in the cyan cartridge contact assembly to make sure it moves freely.</p>  <p style="text-align: center;">B</p> <p>Does the pin move freely?</p>	Go to step 3	Replace the cartridge contact assembly.

Step	Actions and questions	Yes	No
3	<p>Press the TMC pin in the cyan cartridge contact assembly make sure it actuates the TMC switch on the developer HVPS. When the TMC pin is pressed you hear a <i>click</i> when the switch actuates. Check for mechanical interference between the contact block and the developer HVPS.</p> <p>Note: You may need to turn the printer off to hear the <i>click</i>.</p> <p>Does the cyan TMC switch on the developer HVPS board actuate properly when the TMC pin is pressed?</p>	Replace the cartridge.	Go to step 4
4	<p>Check the developer HVPS board to make sure it is not cracked or broken.</p> <p>Is the developer HVPS board cracked or broken?</p>	Replace the developer HVPS board assembly.	Go to step 5
5	<p>Check the mounting of the developer HVPS. Make sure the screws that mount the power supply are properly tightened and the board is positioned and mounted correctly.</p> <p>Is the developer HVPS mounted correctly?</p>	Go to step 6	If the board is incorrectly installed, install it correctly. Make sure all the mounting screws are tightened. Recheck the printer to see if a 940 error is still displayed.
6	<p>Make sure the developer HVPS cable is correctly installed on the developer board assembly.</p> <p>Is the cable correctly installed?</p>	Go to step 7	Correctly connect the cable.
7	<p>Make sure the developer HVPS cable is correctly installed at J20 on the engine board.</p> <p>Is the cable properly installed?</p>	Go to step 8	Correctly connect the cable.
8	<p>Check the voltage at connector J20-9 on the engine board while pressing the cyan TMC pin in the cartridge contact assembly.</p> <p>Does the voltage change when the pin is pressed?</p>	Replace the engine board assembly.	Go to step 9
9	<p>Check the voltage at connector J20-9 when the cyan TMC switch is pressed.</p> <p>Does the voltage measure approximately +3.3 V dc?</p>	Go to step 10	Go to step 11
10	<p>Check the developer HVPS to engine board cable for damage, broken connections, or wire and shorts between adjacent pins.</p> <p>Are there any signs of damage to the cable?</p>	Replace the cable.	Replace the developer HVPS board assembly.
11	<p>Disconnect the developer HVPS cable from connector J20 on the engine board. Measure the voltage on connector J20-9 on the engine board.</p> <p>Does the voltage measure approximately 0 V dc?</p>	Replace the engine board assembly.	Replace the developer HVPS and developer HVPS to engine board cable.

941 Error code

Magenta toner metering cycle (TMC)

Toner metering cycle (TMC) is where the code and electronics in the printer sense an addition of toner in the cartridge developing area. If the printer is expecting a toner addition cycle but one is not detected, a 94x TMC Error is displayed.

Replacement of the cartridge may fix the problem temporarily if the problem is with the printer. Only replace the cartridge if there are no problems with the printer or if the cartridge is known to be defective.

Note: Before proceeding with this service check, observe the error log for repetitive occurrences of a 94x service error.

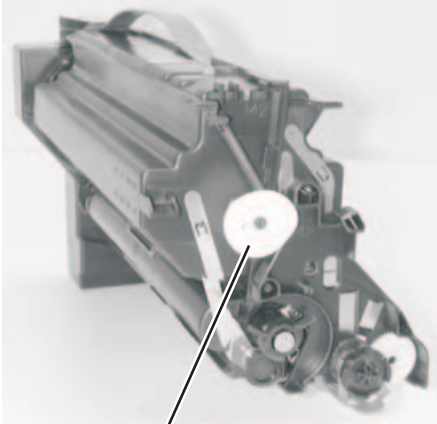
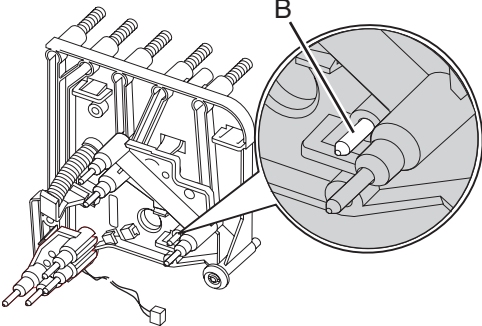
Step	Actions and questions	Yes	No
1	<p>Check the toner metering cam (A) on the rear of the magenta cartridge.</p> <p>Note: In some cartridges, the toner metering cam is black.</p>  <p style="text-align: center;">A</p> <p>Is the cam present on the cartridge?</p>	Go to step 2	<p>If the toner metering cam is not present, check the printer to make sure it is not inside.</p> <p>Replace the damaged cartridge.</p>
2	<p>Check the TMC pin (B) in the magenta cartridge contact assembly to make sure it moves freely.</p>  <p style="text-align: center;">B</p> <p>Does the pin move freely?</p>	Go to step 3	Replace the cartridge contact assembly.

Step	Actions and questions	Yes	No
3	<p>Press the TMC pin in the magenta cartridge contact assembly to make sure it actuates the TMC switch on the developer HVPS. When the TMC pin is pressed you hear a <i>click</i> when the switch actuates. Check for mechanical interference between the contact block and the developer HVPS.</p> <p>Note: You may need to turn the printer off to hear the <i>click</i>.</p> <p>Does the magenta TMC switch on the developer HVPS board actuate properly when the TMC pin is pressed?</p>	Replace the cartridge.	Go to step 4
4	<p>Check the developer HVPS board to make sure it is not cracked or broken.</p> <p>Is the developer HVPS board cracked or broken?'</p>	Replace the developer HVPS board assembly.	Go to step 5
5	<p>Check the mounting of the developer HVPS. Make sure the screws that mount the power supply are properly tightened and the board is positioned and mounted correctly.</p> <p>Is the developer HVPS mounted correctly?</p>	Go to step 6	If the board is incorrectly installed, install it correctly. Make sure all the mounting screws are tightened. Recheck the printer to see if a 941 error is still displayed.
6	<p>Make sure the developer HVPS cable is correctly installed on the developer board assembly.</p> <p>Is the cable correctly installed?</p>	Go to step 7	Correctly connect the cable.
7	<p>Make sure the developer HVPS cable is correctly installed at J20 on the engine board.</p> <p>Is the cable properly installed?</p>	Go to step 8	Correctly connect the cable.
8	<p>Check the voltage at connector J20-5 on the engine board while pressing the magenta TMC pin in the cartridge contact assembly.</p> <p>Does the voltage change when the pin is pressed?</p>	Replace the engine board assembly.	Go to step 9
9	<p>Check the voltage at connector J20-5 when the magenta TMC switch is pressed.</p> <p>Does the voltage measure approximately +3.3 V dc?</p>	Go to step 10	Go to step 11
10	<p>Check the developer HVPS to engine board cable for damage, broken connections, or wire and shorts between adjacent pins.</p> <p>Are there any signs of damage to the cable?</p>	Replace the cable.	Replace the developer HVPS board assembly.
11	<p>Disconnect the developer HVPS cable from connector J20 on the engine board. Measure the voltage on connector J20-5 on the engine board.</p> <p>Does the voltage measure approximately 0 V dc?</p>	Replace the engine board assembly.	Replace the developer HVPS and developer HVPS to engine board cable.

942 Error code

Yellow toner metering cycle (TMC)

Toner metering cycle (TMC) is where the code and electronics in the printer sense an addition of toner in the cartridge developing area. If the printer is expecting a toner addition cycle but one is not detected, a 94x TMC Error is displayed.

Replacement of the cartridge may fix the problem temporarily if the problem is with the printer. Only replace the cartridge if there are no problems with the printer or if the cartridge is known to be defective.

Note: Before proceeding with this service check, observe the error log for repetitive occurrences of a 94x service error.

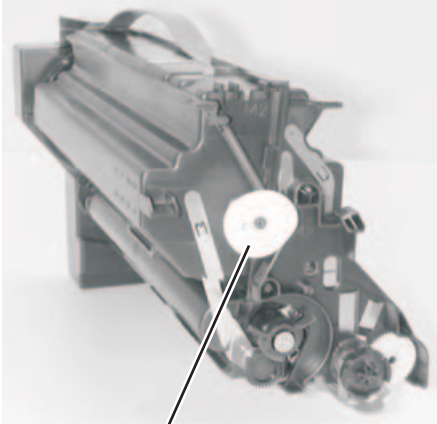
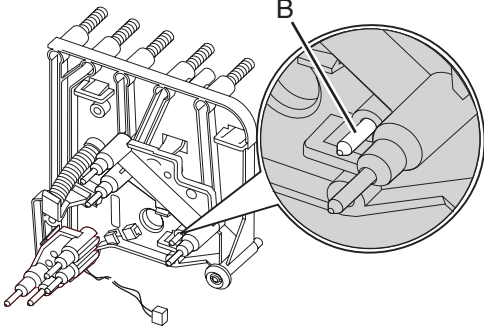
Step	Actions and questions	Yes	No
1	<p>Check the toner metering cam (A) on the rear of the yellow cartridge.</p> <p>Note: In some cartridges the toner metering cam is black.</p>  <p style="text-align: center;">A</p> <p>Is the cam present on the cartridge?</p>	Go to step 2	<p>If the toner metering cam is not present, check the printer to make sure it is not inside.</p> <p>Replace the damaged cartridge.</p>
2	<p>Check the TMC pin (B) in the yellow cartridge contact assembly to make sure it moves freely.</p>  <p style="text-align: center;">B</p> <p>Does the pin move freely?</p>	Go to step 3	Replace the cartridge contact assembly.

Step	Actions and questions	Yes	No
3	<p>Press the TMC pin in the yellow cartridge contact assembly make sure it actuates the TMC switch on the developer HVPS. When the TMC pin is pressed you hear a <i>click</i> when the switch actuates. Check for mechanical interference between the contact block and the developer HVPS.</p> <p>Press the TMC pin in the yellow cartridge contact assembly and check to make sure it actuates the TMC switch on the developer HVPS. When the TMC pin is pressed in you should be able to hear a <i>click</i> when the switch actuates.</p> <p>Note: You may need to turn the printer off to hear the <i>click</i>.</p> <p>Does the yellow TMC switch on the developer HVPS board actuate properly when the TMC pin is pressed?</p>	Replace the cartridge.	Go to step 4
4	<p>Check the developer HVPS board to make sure it is not cracked or broken.</p> <p>Is the developer HVPS board cracked or broken?'</p>	Replace the developer HVPS board assembly.	Go to step 5
5	<p>Check the mounting of the developer HVPS. Make sure the screws that mount the power supply are properly tightened and the board is positioned and mounted correctly.</p> <p>Is the developer HVPS mounted correctly?</p>	Go to step 6	If the board is incorrectly installed, install it correctly. Make sure all the mounting screws are tightened. Recheck the printer to see if a 942 Error is still displayed.
6	<p>Make sure the developer HVPS cable is correctly installed on the developer board assembly.</p> <p>Is the cable correctly installed?</p>	Go to step 7	Correctly connect the cable.
7	<p>Make sure the developer HVPS cable is correctly installed at J20 on the engine board.</p> <p>Is the cable properly installed?</p>	Go to step 8	Correctly connect the cable.
8	<p>Check the voltage at connector J20-13 on the engine board while pressing the yellow TMC pin in the cartridge contact assembly.</p> <p>Does the voltage change when the pin is pressed?</p>	Replace the engine board assembly.	Go to step 9
9	<p>Check the voltage at connector J20-13 when the yellow TMC switch is pressed.</p> <p>Does the voltage measure approximately +3.3 V dc?</p>	Go to step 10	Go to step 11
10	<p>Check the developer HVPS to engine board cable for damage, broken connections, or wire and shorts between adjacent pins.</p> <p>Are there any signs of damage to the cable?</p>	Replace the cable.	Replace the developer HVPS board assembly.
11	<p>Disconnect the developer HVPS cable from connector J20 on the engine board. Measure the voltage on connector J20-13 on the engine board.</p> <p>Does the voltage measure approximately 0 V dc?</p>	Replace the engine board assembly.	Replace the developer HVPS and developer HVPS to engine board cable.

943 Error code

Black toner metering cycle (TMC)

Toner metering cycle (TMC) is where the code and electronics in the printer sense an addition of toner in the cartridge developing area. If the printer is expecting a toner addition cycle but one is not detected, a 94x TMC Error is displayed.

Replacement of the cartridge may fix the problem temporarily if the problem is with the printer. Only replace the cartridge if there are no problems with the printer or if the cartridge is known to be defective.

Note: Before proceeding with this service check, observe the error log for repetitive occurrences of a 94x service error.

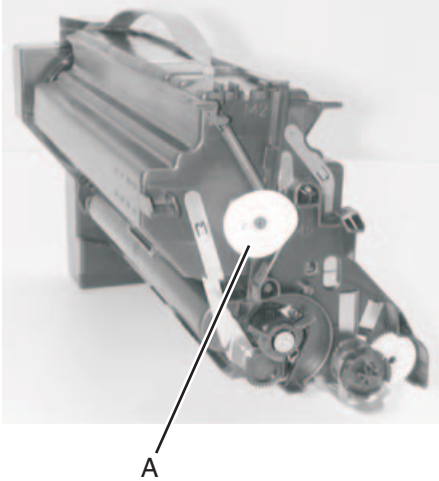
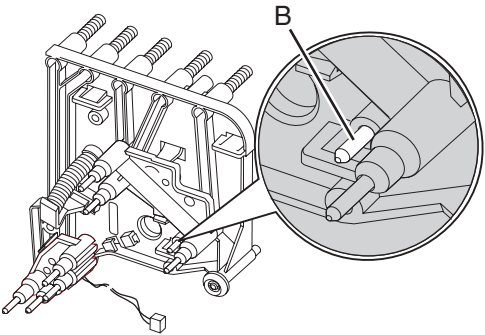
Step	Actions and questions	Yes	No
1	<p>Check the toner metering cam (A) on the rear of the black cartridge.</p> <p>Note: In some cartridges the toner metering cam is black. the cam present on the cartridge?</p> 	Go to step 2	<p>If the toner metering cam is not present, check the printer to make sure it is not inside.</p> <p>Replace the damaged cartridge.</p>
2	<p>Check the TMC pin (B) in the black cartridge contact assembly to make sure it moves freely.</p>  <p>Does the pin move freely?</p>	Go to step 3	Replace the cartridge contact assembly.

Step	Actions and questions	Yes	No
3	<p>Press the TMC pin in the black cartridge contact assembly make sure it actuates the TMC switch on the developer HVPS. When the TMC pin is pressed you hear a <i>click</i> when the switch actuates. Check for mechanical interference between the contact block and the developer HVPS.</p> <p>Note: You may need to turn the printer off to hear the <i>click</i>.</p> <p>Does the black TMC switch on the developer HVPS board actuate properly when the TMC pin is pressed?</p>	Replace the cartridge.	Go to step 4
4	<p>Check the developer HVPS board to make sure it is not cracked or broken.</p> <p>Is the developer HVPS board cracked or broken?'</p>	Replace the developer HVPS board assembly.	Go to step 5
5	<p>Check the mounting of the developer HVPS. Make sure the screws that mount the power supply are properly tightened and the board is positioned and mounted correctly.</p> <p>Is the developer HVPS mounted correctly?</p>	Go to step 6	If the board is incorrectly installed, install it correctly. Make sure all the mounting screws are tightened. Recheck the printer to see if a 943 error is still displayed.
6	<p>Make sure the developer HVPS cable is correctly installed on the developer board assembly.</p> <p>Is the cable correctly installed?</p>	Go to step 7	Correctly connect the cable.
7	<p>Make sure the developer HVPS cable is correctly installed at J20 on the engine board.</p> <p>Is the cable properly installed?</p>	Go to step 8	Correctly connect the cable.
8	<p>Check the voltage at connector J20-1 on the engine board while pressing the black TMC pin in the cartridge contact assembly.</p> <p>Does the voltage change when the pin is pressed?</p>	Replace the engine board assembly.	Go to step 9
9	<p>Check the voltage at connector J20-1 when the black TMC switch is pressed.</p> <p>Does the voltage measure approximately +3.3 V dc?</p>	Go to step 10	Go to step 11
10	<p>Check the developer HVPS to engine board cable for damage, broken connections, or wire and shorts between adjacent pins.</p> <p>Are there any signs of damage to the cable?</p>	Replace the cable.	Replace the developer HVPS board assembly.
11	<p>Disconnect the developer HVPS cable from connector J20 on the engine board. Measure the voltage on connector J20-1 on the engine board.</p> <p>Does the voltage measure approximately 0 V dc?</p>	Replace the engine board assembly.	Replace the developer HVPS and developer HVPS to engine board cable.

990 Service error

This error indicates which option is causing the error.

5-Bin mailbox

Step	Action and questions	Yes	No										
1	Mechanical linkage/DC motor assembly—make sure the DC motor cable connector is installed at J2 on the control board. Is the cable connected correctly?	Go to step 2	Reseat the cable and recheck for correct operation of the option										
2	Resistance check—disconnect J2 from the option board and check the resistance of the motor on the cable connector between J2-1 and J2-2. The resistance measures between 115 and 135 ohms. Is the resistance correct?	Go to step 3	Replace the mechanical linkage/DC motor assembly										
3	DC motor—check between J2-1 and between J2-2 and the case of the DC motor for shorts. Is the DC motor-shorted? Note: If the DC motor is shorted, damage may result to the Control board.	Replace the mechanical linkage/DC motor assembly	Go to step 4										
4	Output Expander control board check—disconnect the motor cable J2 and check the voltages at J2 on the board. Warning: Be careful not to short to adjacent pins on the connector. Note: All voltages are approximate values. <table border="1" data-bbox="418 1094 829 1268"> <thead> <tr> <th>Pins</th> <th>Voltages (motor idle)</th> </tr> </thead> <tbody> <tr> <td>J2-1</td> <td>+24 V dc</td> </tr> <tr> <td>J2-2</td> <td>+24 V dc</td> </tr> <tr> <td>J2-3</td> <td>+5 V dc</td> </tr> <tr> <td>J2-4</td> <td>+5 V dc</td> </tr> </tbody> </table> Are the voltages correct?	Pins	Voltages (motor idle)	J2-1	+24 V dc	J2-2	+24 V dc	J2-3	+5 V dc	J2-4	+5 V dc	Replace the control board	Replace the mechanical linkage/DC motor assembly
Pins	Voltages (motor idle)												
J2-1	+24 V dc												
J2-2	+24 V dc												
J2-3	+5 V dc												
J2-4	+5 V dc												

500-sheet drawer

For 990 Service Error - Tray x , x =Tray 2, 3, 4 or 5, this is the tray that has a problem or needs service.

Note: Verify the autoconnect housing is correctly snapped into the printer and all options, and is plugged into the system board correctly.

Step	Action and questions	Yes	No
1	Make sure the autocompensator cable is correctly installed at the tray System board. Is the cable correctly installed?	Go to step 2	Install the cable correctly
2	Make sure the drive assembly cable is connected correctly to the tray system board. Is the cable correctly installed?	Go to step 3	Install the cable correctly
3	Check for worn or broken parts in the autocompensator and drive assemblies. Are any parts worn, broken, or damaged?	Replace the assembly that has the defective parts	Replace the FRUs in the following order: 1. Electronic/ size sensing assembly 2. Autocompensator assembly 3. Drive assembly

Output expander

Step	Actions and questions	Yes	No
1	Mechanical linkage/DC motor assembly—check the DC motor cable connector to make sure it is installed at J4 on the output expander control board. Is the cable connected correctly?	Go to step 2	Reseat the cable and recheck for correct operation of the option
2	Resistance check—disconnect J4 from the option board and check the resistance of the motor on the cable connector between J4-1 and J4-2. The resistance should measure between 115 and 135 ohms. Is the resistance correct?	Go to step 3	Replace the mechanical linkage/DC motor assembly
3	DC Motor—check between J4-1 and between J4-2 and the case of the DC motor for shorts. Is the DC motor shorted? Note: If the DC motor is found to be shorted damage may result to the RIP board.	Replace the mechanical linkage/DC motor assembly	Go to step 4

Step	Actions and questions	Yes	No										
4	<p>Output Expander control board check—disconnect the motor cable J4 and check the voltages at J4 on the board. Warning: Be careful not to short to adjacent pins on the connector.</p> <p>The voltages measure approximate.</p> <table border="1"> <thead> <tr> <th>Pins</th> <th>Voltages (motor idle)</th> </tr> </thead> <tbody> <tr> <td>J4-1</td> <td>+24 V dc</td> </tr> <tr> <td>J4-2</td> <td>+24 V dc</td> </tr> <tr> <td>J4-3</td> <td>+5 V dc</td> </tr> <tr> <td>J4-4</td> <td>+5 V dc</td> </tr> </tbody> </table> <p>Are the voltages correct?</p>	Pins	Voltages (motor idle)	J4-1	+24 V dc	J4-2	+24 V dc	J4-3	+5 V dc	J4-4	+5 V dc	Replace the Output Expander control board	Replace the mechanical linkage/DC motor assembly
Pins	Voltages (motor idle)												
J4-1	+24 V dc												
J4-2	+24 V dc												
J4-3	+5 V dc												
J4-4	+5 V dc												

Finisher

Step	Actions and questions	Yes	No												
1	<p>Make sure the top options cable is correctly plugged into the system board.</p> <p>Is the cable correctly installed?</p>	Go to step 2	Install correctly												
2	<p>Make sure the finisher cable is correctly installed on top of the printer.</p> <p>Is the cable correctly installed?</p>	Go to step 3	Install correctly												
3	<p>Make sure the finisher cable is correctly installed on the finisher system board.</p> <p>Is the cable correctly installed?</p>	Go to step 4	Install correctly												
4	<p>When 990 error is installed, press and hold Return and Select to view the sub error code.</p> <p>Scroll down with Menu to see the additional display lines and view the value at the indicated position (EQC and DB1) and match the information to the table below.</p> <p>Finisher (Bin 1) - No other output options</p> <table border="1"> <tbody> <tr> <td>26</td> <td>9D</td> <td>81</td> <td>EQC</td> </tr> <tr> <td>DB1</td> <td>DB2</td> <td>DB3</td> <td>DB4</td> </tr> <tr> <td>DB5</td> <td>DB6</td> <td>DB7</td> <td></td> </tr> </tbody> </table> <p>Does the information on the table help find the problem?</p>	26	9D	81	EQC	DB1	DB2	DB3	DB4	DB5	DB6	DB7		Repair the finisher as indicated in the table.	Contact your next level of support.
26	9D	81	EQC												
DB1	DB2	DB3	DB4												
DB5	DB6	DB7													

EQC	DB1	Explanation
45	05	Jogger motor homing timeout error. Obstruction in Jogger, motor or sensor failure.
4C	0C	Offset motor timeout error. No clearance around output bin, motor or sensor failure.
50	10	Stapler unit is removed. Cable harness to stapler damaged or disconnected.

5-Bin mailbox option service check

Note: Make sure the option(s) are installed correctly and the printer is configured correctly. The majority of the mechanical components can be observed during operation by removing the left and right side covers.

Step	Symptoms	Yes	No
1	Problems with excessive static electricity buildup.	Go to step 2	Go to step 3
2	Excessive static electricity buildup—Check the front cover assembly is firmly attached to the 5-bin mailbox frame and the ESD brush is not loose or damaged. Is the ESD brush ground cable correctly installed and the ESD brush not loose or broken?	Make sure the brush is contacting the media being fed through the option.	1. Attach the ground cable if not installed. 2. Replace the cover assembly if the ESD brush is loose or damaged.
3	The printer does not recognize one or more output options as installed.	Go to “The printer does not recognize one or more output options as installed.” on page 2-105	Go to step 4
4	271 Paper Jam - Check Bin 1 message	Go to “272 Paper jam - Check Bin x” on page 2-85	Go to step 5
5	274 Paper Jam - Check Bin 4 displays.	Go to “Ready Bin x Full message—may be able to clear message and paper feeds into bin selected.” on page 2-106	Go to step 6
6	Ready Bin x Full message—May be able to clear message and will feed paper into Bin selected.	Go to “Ready Bin x Full message—may be able to clear message and paper feeds into bin selected.” on page 2-106	Go to step 7
7	Bin x Full - No message that Bin x is full	Go to “Bin x Full—no message that Bin x is full” on page 2-107	Go to step 8
8	Ready - Bin x Full displays and paper feeds into Bin x	Go to “Ready - Bin x Full displays and paper feeds into bin x” on page 2-107	Go to step 9
9	Paper does not feed into the bin selected. 271 Paper Jam - check bin 1 appears	Go to “Paper does not feed into the 5-Bin mailbox bin selected. 271 Paper Jam - Check Bin 1 message” on page 2-106	Go to step 10

Step	Symptoms	Yes	No
10	990 Service Error	Go to “990 Service error” on page 2-101	Call your next level support

The printer does not recognize one or more output options as installed.

Note: If more than a single output option is installed, check each one to see if the printer recognizes any single option as being installed. If the printer recognizes any of the output options then the base printer autoconnect system is operating correctly and the problem is in the unrecognized option. Continue with this service check or go to service check of the failing output option.

Step	Action and questions	Yes	No
1	Options—make sure that the output expander option is the only output option that is not recognized by the base printer. Is this the only output option not recognized by the base printer?	Go to step 2	Check the autoconnect system in base printer
2	Mechanical linkage (tables)—check the 5-bin mailbox autoconnect cable and connector for any signs of damage, especially the connector pins. Is there any signs of damage to the cable, connector, or connector pins?	Replace the Autoconnect cable	Go to step 3
3	Mechanical linkage (electrical)—make sure the autoconnect cables are connected correctly to the control board. Are the cables attached securely and correctly?	Go to step 4	Reseat the cables
4	Voltage check, base printer autoconnect connector—turn the power off and remove the 5-bin mailbox option from the printer. Check the voltages on the base printer top autoconnect connector. Go to autoconnect - top. Are the voltages correct?	Go to step 5	Check the autoconnects in the printer
5	Voltage check, 5-bin mailbox system board—reinstall the 5-bin mailbox option and check the voltages at J1A and J1B on the connector. Are the voltages correct?	Replace the output expander option system board	Replace the output expander option mechanical linkage assembly

Paper does not feed into the 5-Bin mailbox bin selected. 271 Paper Jam - Check Bin 1 message

Step	Action and questions	Yes	No
1	Bin parts—check all the bin parts, deflector, deflector spring, deflector cover, deflector cover spring, and shaft assemblies for signs of missing or loose springs. Check for binds in the deflector or deflector cover, broken or binding shaft assemblies, or broken gear teeth. Are parts broken, loose, binding, or missing?	Replace parts or repairs necessary	Go to step 2
2	Bin x solenoid—check the solenoid for any binds or sticking problems. Is the solenoid binding or sticking?	Replace the solenoid assembly	Go to step 3
3	Bin x solenoid—check the resistance of the solenoid. It measures between approximately 30 ohms and 50 ohms. Is the resistance correct?	Replace the 5-bin mailbox control board assembly	Replace bin x solenoid assembly
4	Mechanical linkage/motor assembly—check the gears, clutch and other linkage parts for correct operation and any signs of wear, broken gear teeth or damaged parts. Are the mechanical linkage assembly mechanical parts broken, worn or damaged?	Replace the mechanical linkage/DC motor assembly	Replace the 5-bin mailbox control board assembly

Ready Bin x Full message—may be able to clear message and paper feeds into bin selected.

Note: This sensor is normally in a open position with the flag out of the sensor slot.

Step	Action and questions	Yes	No
1	Bin x sensor (Bin x=sensor 1 through 5)—make sure the sensor is seated correctly in the side of tray x. Is the sensor seated correctly?	Go to step 2	Install the sensor correctly
2	Bin x sensor cable—make sure that Bin x sensor cable is connected to the sensor and to the control board. Is the sensor cable connected correctly?	Go to step 3	Install the sensor cable correctly
3	Bin x sensor flag—check the Bin x sensor flag for binding and proper operation. Are there any problems with the sensor flag?	Repair or replace the sensor flag	Go to step 4
4	Bin x sensor cable—check the continuity of the sensor cable. Is there continuity?	Replace the Bin x sensor	Replace the Bin x cable

Bin x Full—no message that Bin x is full

Step	Action and questions	Yes	No
1	Bin x sensor (Bin x=sensor 1 through 5)—make sure the sensor is seated correctly in the side of tray x. Is the sensor seated correctly?	Go to step 2	Install the sensor correctly
2	Bin x sensor cable—make sure that Bin x sensor cable is connected to the sensor and to the control board. Is the sensor cable connected correctly?	Go to step 3	Install the sensor cable correctly
3	Bin x sensor flag—check the Bin x sensor flag for binding and proper operation. Are there any problems with the sensor flag?	Repair or replace the sensor flag	Go to step 4
4	Bin x sensor cable—check the continuity of the sensor cable. Is there continuity?	Replace the Bin x sensor	Replace the Bin x cable

Ready - Bin x Full displays and paper feeds into bin x

Step	Action and questions	Yes	No
1	Bin x sensor flag—make sure the Bin x sensor flag is not in the up position and is operating correctly. Is the sensor flag operating correctly?	Replace the Bin x sensor. If this does not fix the problem replace the control board.	Repair or replace as necessary

500-Sheet drawer option service check

If the paper does not feed from the 500-sheet option, see **“Autocompensator service check” on page 2-114.**

Whenever the 500-Sheet Tray is removed, use care as the autocompensator may be in its down position which could result in damage to the autocompensator assembly.

The tray empty sensor, paper low sensor, and pass thru sensor for any installed tray x (x=2 through 4) can be checked using the Input Tray **“Sensor Test” on page 3-24.**

The base printer does not recognize that tray x is installed.

Step	Action and questions	Yes	No												
1	Is tray x the only paper input option that is not recognized?	Go to step 5	Go to step 2												
2	Make sure the printer and any option above tray x is installed correctly. Is the printer and any options installed correctly?	Go to step 3	Install the option correctly and recheck												
3	Verify correct installation of the lower options autoconnect cable to engine board connector J5. Is the cable to J5 installed correctly?	Go to step 4	Install the cable correctly and recheck												
4	Autoconnect cables—check the autoconnect from the printer or option above tray x. Check for cuts, pinched wiring, or damage to the contacts in the connector. Are there any problems with the autoconnect cables?	Repair or replace as necessary	Go to step 5												
5	Tray x autoconnect cable—check the tray x autoconnect cable(s) for correct installation at the tray x system board. Are the tray x autoconnect cable(s) connected correctly?	Go to step 6	Install the cables correctly and recheck												
6	Tray x autoconnect cable continuity—check the continuity of the tray x autoconnect cable(s). Is there continuity?	Go to step 7	Replace electronic size sensing assembly (includes the system board)												
7	Disconnect J5 from the engine board and check the voltages on connector J5 on the engine board. The voltages should measure: Note: All voltages are approximate values. <table border="1" data-bbox="370 1459 659 1669"> <thead> <tr> <th>Connector pins</th> <th>Voltage</th> </tr> </thead> <tbody> <tr> <td>J5-1</td> <td>+24 V dc</td> </tr> <tr> <td>J5-3</td> <td>+5 V dc</td> </tr> <tr> <td>J5-5</td> <td>+5 V dc</td> </tr> <tr> <td>J5-6</td> <td>+5 V dc</td> </tr> <tr> <td>J5-8</td> <td>+5 V dc</td> </tr> </tbody> </table> Are the voltages correct?	Connector pins	Voltage	J5-1	+24 V dc	J5-3	+5 V dc	J5-5	+5 V dc	J5-6	+5 V dc	J5-8	+5 V dc	Replace electronic size sensing assembly (includes the system board)	Replace the engine board
Connector pins	Voltage														
J5-1	+24 V dc														
J5-3	+5 V dc														
J5-5	+5 V dc														
J5-6	+5 V dc														
J5-8	+5 V dc														

Tray x autocompensator fails to retract, stays in down position.

Step	Action and questions	Yes	No
1	Use care when removing a tray assembly when the autocompensator is in its down position. Remove the tray and manually reset the autocompensator to its uppermost position by actuating the pick arm lift bellcrank. Does the autocompensator assembly stay in the up position?	Go to step 2	Go to step 3
2	Carefully replace the tray and recheck to see if the autocompensator operates correctly. Does the autocompensator assembly operate correctly?	Problem solved	Go to step 3
3	Make sure the autocompensator pick arm lift bellcrank is installed correctly. Is the pick arm lift bellcrank installed correctly?	Go to step 4	Install the bellcrank correctly
4	Check the following for loose, broken or missing parts: <ul style="list-style-type: none"> • Boss on the side of the arm • Bellcrank lift spring • Tray interlock bellcrank Are any of these parts loose, broken or missing?	Repair or replace as necessary	Call your next level of support.

The printer does not detect paper low in Tray x when adequate paper is installed in the tray.

Step	Action and questions	Yes	No
1	Run tray x sensor test from the Diagnostics Menu. Does the test pass for sensor L2?	Go to step 3	Go to step 2
2	Check the cable connection for the paper low/out sensor to tray x system board. Is the cable correctly installed?	Go to step 3	Install the cable correctly
3	Check the paper level sensing assembly for correct installation. Check the following for damaged or broken parts: <ul style="list-style-type: none"> • Paper level sensing flag bellcrank. • Paper level sensor is seated correctly. • Paper level sensing flag. • Paper level sensing flag spring. Is the paper level sensing assembly installed correctly?	Go to step 4	Install the paper level sensing assembly correctly
4	Is the paper level sensing assembly damaged or broken?	Replace the paper level sensing assembly	

The printer does not detect paper out in tray x when adequate paper is installed in the tray.

Step	Action and questions	Yes	No
1	Run tray x sensor test from the Diagnostics Menu. Does the test pass for sensor L1?	Go to step 5	Go to step 2
2	Check the cable connection for the paper level sensing assembly to tray x system board. Is the cable correctly installed?	Go to step 3	Install the cable correctly
3	Check the paper level sensing assembly for correct installation. Is the paper level sensing assembly installed correctly?	Go to step 4	Reinstall the assembly if not installed correctly
4	Check continuity of the paper level sensing assembly cable. Do you measure continuity?	Go to step 5	Replace the cable
5	Check the paper level sensing assembly for correct installation. Check the following for damaged or broken parts: <ul style="list-style-type: none"> • Paper level sensing flag bellcrank. • Paper level sensing flag. • Paper level sensing flag spring. Is the paper level sensing assembly installed correctly?	Replace the paper level sensing assembly	Go to step 6
6	Make sure the paper level sensing assembly arm goes all the way to the bottom of tray x. Does the arm extend all the way down to the bottom of the tray?	Recheck the arm. If the problem continues, replace the paper leveling sensing assembly. If this does not fix the problem, replace the Tray x system board.	See why the arm is not extending all the way to the bottom of the tray. Repair as necessary.

The printer does not detect transparencies loaded in Tray x

Step	Action and questions	Yes	No
1	Make sure the transparency material meets specifications. Does the transparency material meet specifications?	Go to step 2	Inform the customer that the transparency media in tray x does not meet specification
2	Check the transparency sensing assembly for correct installation. Is the transparency sensing assembly correctly installed?	Go to step 3	Install the transparency assembly correctly
3	Check the transparency sensing assembly cable to make sure the in-line connector is correctly installed to Tray x system board cable. Is the cable correctly installed?	Go to step 4	Install the cable correctly

Step	Action and questions	Yes	No
4	<p>Check the transparency sensing assembly cable for correct installation to Tray x system board.</p> <p>Is the cable connected correctly?</p>	<p>Replace the FRUs in the following order:</p> <ol style="list-style-type: none"> 1. Autocompensator assembly See “Auto-compensator pick assembly removal” on page 4-17. 2. Electronics/size sensing assembly 	Install the cable correctly

Tray x does not detect size media is installed

Step	Action and questions	Yes	No
1	Is the tray set for the size paper loaded in the tray?	Go to step 2	Set the correct size
2	Are there damaged or broken size sensing gears or size sensing barrel cam in the tray assembly?	Repair or replace defective parts	Go to step 3
3	<p>Check the paper size sensing assembly for any signs of damaged or broken parts.</p> <p>Are there broken or damaged parts?</p>	Replace the paper size sensing assembly	Replace the electronics/ size sensing assembly

AC and DC power service check

Before proceeding with this service check remove or disconnect any options that may be installed. Turn the machine on. If it operates correctly, reattach one option at a time until the failing option is located.

Note: Before proceeding with this service check turn the printer on and check to see if the Power on LED on the engine board is turned on.

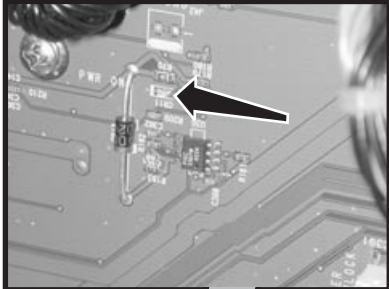
Step	Actions and questions	Yes	No
1	Is the Power on LED on the engine board turned on? 	Go to “AC power service check” on page 2-112.	Go to “DC power service check” on page 2-113.



AC power service check

The printer appears to be inoperative when turned on with the Power on/Status LED off, the LCD display is blank, the Fuser lamps do not come on and no motors turn.

Step	Actions and questions	Yes	No
1	Main AC power—make sure the printer is receiving main AC power. Is the printer receiving AC power?	Go to step 2	Inform the customer that AC power to the printer is incorrect.
2	AC power check (wall outlet)—check the AC line voltage at the AC outlet. Is the AC line voltage correct?	Go to step 3	Inform the customer that the AC line voltage is incorrect
3	AC power cord. Is the power cord in good condition?	Go to step 4	If the cord is in poor condition, replace the cord
4	AC Power—Is the power cord plugged into an approved AC outlet. It should not be plugged into a power strip or interruptible power supply. Is the power cord plugged into a correct AC outlet?	Go to step 5	Plug the power cord into the correct AC outlet. If an outlet is not available, inform the customer.
5	AC power check (AC line cord)—check the AC line voltage at the end of the AC line cord. Is the AC line voltage correct?	Go to step 6	Replace the line cord
6	Low voltage power supply—turn the power off and disconnect the LVPS from the RIP and engine boards. Check for +5 V dc on the LVPS cables. engine board +5 V dc: J9-2 and J9-3. RIP board +5 V dc: J23-13, J23-14, and J23-15. Is there approximately +5 V dc on all of these connector pins?	Go to “DC power service check” on page 2-113.	Replace the LVPS. See “Low voltage power supply (LVPS) removal” on page 4-38.

DC power service check

The machine is partially operative, a motor turns, display is on or the power-on LED may be on or off.

Step	Actions and questions	Yes	No																																
1	Does the printer <i>beep</i> 5 times and the operator panel display all diamonds?	Go to “Operator panel LCD/status LED/buttons service check” on page 2-132.	Go to step 2																																
2	<p>DC power to engine board—turn the power off and disconnect the LVPS cable to J9 on the engine board. Turn the power on and check the following voltages on the LVPS cable.</p> <table border="1"> <tbody> <tr><td>J9-1</td><td>+3.3 V dc</td></tr> <tr><td>J9-2</td><td>+5 V dc</td></tr> <tr><td>J9-3</td><td>+5 V dc</td></tr> <tr><td>J9-4</td><td>+24 V dc</td></tr> <tr><td>J9-5</td><td>+24 V dc</td></tr> <tr><td>J9-6</td><td>Ground</td></tr> <tr><td>J9-7</td><td>Ground</td></tr> <tr><td>J9-8</td><td>Ground</td></tr> <tr><td>J9-9</td><td>Ground</td></tr> <tr><td>J9-10</td><td>Ground</td></tr> </tbody> </table> <p>Note: All voltages are approximate values. Are the voltages correct?</p>	J9-1	+3.3 V dc	J9-2	+5 V dc	J9-3	+5 V dc	J9-4	+24 V dc	J9-5	+24 V dc	J9-6	Ground	J9-7	Ground	J9-8	Ground	J9-9	Ground	J9-10	Ground	Go to step 3	Replace the LVPS. See “Low voltage power supply (LVPS) removal” on page 4-38.												
J9-1	+3.3 V dc																																		
J9-2	+5 V dc																																		
J9-3	+5 V dc																																		
J9-4	+24 V dc																																		
J9-5	+24 V dc																																		
J9-6	Ground																																		
J9-7	Ground																																		
J9-8	Ground																																		
J9-9	Ground																																		
J9-10	Ground																																		
3	<p>DC voltages at RIP board—turn the power off and disconnect the LVPS cable to J23 on the RIP board. Turn the power supply assembly power on and check the following voltages on the LVPS cable:</p> <table border="1"> <tbody> <tr><td>J23-1</td><td>Ground</td></tr> <tr><td>J23-2</td><td>Ground</td></tr> <tr><td>J23-3</td><td>Ground</td></tr> <tr><td>J23-4</td><td>Ground</td></tr> <tr><td>J23-5</td><td>Ground</td></tr> <tr><td>J23-6</td><td>Ground</td></tr> <tr><td>J23-7</td><td>Ground</td></tr> <tr><td>J23-8</td><td>Ground</td></tr> <tr><td>J23-9</td><td></td></tr> <tr><td>J23-10</td><td>+3.3 V dc</td></tr> <tr><td>J23-11</td><td>+3.3 V dc</td></tr> <tr><td>J23-12</td><td>+3.3 V dc</td></tr> <tr><td>J23-13</td><td>+5.0 V dc</td></tr> <tr><td>J23-14</td><td>+5.0 V dc</td></tr> <tr><td>J23-15</td><td>+5.0 V dc</td></tr> <tr><td>J23-16</td><td>+24 V dc</td></tr> </tbody> </table> <p>Note: All voltages are approximate values. Are the voltages correct?</p>	J23-1	Ground	J23-2	Ground	J23-3	Ground	J23-4	Ground	J23-5	Ground	J23-6	Ground	J23-7	Ground	J23-8	Ground	J23-9		J23-10	+3.3 V dc	J23-11	+3.3 V dc	J23-12	+3.3 V dc	J23-13	+5.0 V dc	J23-14	+5.0 V dc	J23-15	+5.0 V dc	J23-16	+24 V dc	Go to step 4	Replace the LVPS. See “Low voltage power supply (LVPS) removal” on page 4-38.
J23-1	Ground																																		
J23-2	Ground																																		
J23-3	Ground																																		
J23-4	Ground																																		
J23-5	Ground																																		
J23-6	Ground																																		
J23-7	Ground																																		
J23-8	Ground																																		
J23-9																																			
J23-10	+3.3 V dc																																		
J23-11	+3.3 V dc																																		
J23-12	+3.3 V dc																																		
J23-13	+5.0 V dc																																		
J23-14	+5.0 V dc																																		
J23-15	+5.0 V dc																																		
J23-16	+24 V dc																																		

Step	Actions and questions	Yes	No
4	Unplug all cables from the system board, except J6, J35, J37. See “System board - non-network” on page 5-6 or “System board - network” on page 5-7 . Does the printer power up and display a message?	Go to step 5	Replace the “System board” on page 4-67 .
5	Turn off the printer and plug in the cable for the component that is related to the error presented. For example, for the 114 Service Printhead error, plug in the black printhead J11 and J12. Use connector locations on “System board - non-network” on page 5-6 or “System board - network” on page 5-7 . Repeat this step until the original DC power problem occurs. Does the DC power problem occur?	Check the cable and component that was last connected to system board for a problem such as a short.	If printer comes to Ready, connect the remaining cables and print.

Autocompensator service check

- If the paper fails to feed from Tray 1 or 500-sheet option, go to **“Step A” on page 2-114**.
- If the autocompensator fails to lower when Tray 1 is installed, go to **“Step B” on page 2-115**.
- If the autocompensator fails to retract when you attempt to remove Tray 1, go to **“Step C” on page 2-115**.
- If there is no indication that the media is out or low, go to **“Step D” on page 2-116**.
- If the printer fails to detect transparencies and 203 Paper Jam appears, go to **“Step E” on page 2-116**.

Note: When feeding paper through the printer to check for autocompensator problems, use the Tray 1 Feed test in the Diagnostics Menu. A printed copy is not required.

Step A

Step	Action and questions	Yes	No
1	Use the tray 1 feed test to feed paper from tray 1. Check to see if the pick rolls are turning. Note: Observe the pick rolls by opening the Lower Jam access door assembly. Do the pick rolls turn?	Go to step 2	Go to step 3
2	Check the autocompensator pick rolls for contamination or damage to the rolls. Is there any excessive contamination or damage to the pick rolls?	Replace the pick rolls. Always replace both pick rolls at the same time.	Go to step 3
3	Verify that the autocompensator is not stuck in the up position. Verify that the output clutch assembly is not damaged. Is the autocompensator stuck in the up position or the output clutch damaged?	Dislodge the autocompensator. If this does not fix the problem, go to step 4.	Replace the engine board. See “Engine board removal” on page 4-29 .
4	Check the voltages at J73 on the engine board. Are the voltages correct?	Replace the autocompensator assembly. See “Autocompensator or pick assembly removal” on page 4-17 .	Replace the engine board. See “Engine board removal” on page 4-29 .

Step B

Step	Action and questions	Yes	No
1	Check tray 1 for damage to the pick arm lift bellcrank activation tabs on the rear of the tray. Is there any damage to the tray?	Replace Tray 1.	Go to step 2
2	Check the following parts for damaged, loose or missing parts. <ul style="list-style-type: none"> • Pick arm lift bellcrank • Bellcrank lift spring • Tray interlock bellcrank Are any of the parts broken, loose or missing?	Repair or replace parts as necessary.	Go to step 3
3	Verify the autocompensator is not stuck in the up position (tires or hub caught on the upper deflector)	Dislodge the autocompensator assembly.	Replace the autocompensator. See “Autocompensat or pick assembly removal” on page 4-17.

Step C

Step	Action and questions	Yes	No
1	Can you remove tray 1 from the printer?	Go to step 3	Go to step 2
2	Open the lower jam access door and carefully lift the autocompensator assembly until it is in its upper most position, and carefully try to remove tray 1. Can you remove tray 1?	Go to step 3	Determine what is causing the tray to stay in a locked position. Repair as necessary.
3	Check tray 1 for damage to the pick arm lift bellcrank activation tabs on the rear of the tray. Is there damage to the tray?	Replace Tray 1.	Go to step 4
4	Check for loose or broken parts on the autocompensator assembly. Are there loose or broken parts?	Replace the autocompensator assembly.	Go to step 5
5	Check the following parts for any signs of damaged or broken parts. <ul style="list-style-type: none"> • Pick arm lift bellcrank • Pick arm bellcrank lift spring Are there any damaged or broken parts?	Repair or replace parts as necessary	Determine what is causing the autocompensator to stay in the down position. Repair as necessary.

Step D

Step	Action and questions	Yes	No
1	Enter the Diagnostics Mode and select the Tray 1 Sensor Test from the Input Tray Tests menu. You can activate the paper level sensor inside the printer. The paper level sensor is a dual sensor and checks the following levels for tray 1. The tray 1 level sensor is a dual sensor assembly that senses when tray 1 is empty, nearly empty, or partially empty. Does the sensor test pass?	Call your next level support.	Go to step 2
2	Paper level sensing assembly—make sure the assembly is not loose or damaged. Make sure the arm is not broken. Are any parts loose or broken?	Repair or replace parts as necessary.	Go to step 3
3	Check the paper level sensing cable for correct installation at J69 on the engine board and to the paper level sensing dual sensor assembly. Is the cable connected correctly?	Go to step 4	Install the cable correctly
4	Check the paper level sensing assembly flag for correct installation and the flag is not broken or damaged. Is the paper level sensing assembly installed correctly and the flag not broken or damaged?	Go to step 5	Install correctly or replace the flag if damaged or broken
5	Check continuity of the paper level sensing cable. Is there continuity?	Go to step 6	Replace the level sensing cable
6	Check the voltage at J69-1. It should measure approximately +5 V dc. Is the voltage correct?	Replace the level sensing assembly.	Replace the engine board. See “Engine board removal” on page 4-29.

Step E

Step	Action and questions	Yes	No
1	Check the make sure that the transparency material installed in Tray 1 meets machine requirements. Does the media meet requirements?	Go to step 2	Inform the customer
2	Check the following for correct installation and signs of broken or damaged parts: <ul style="list-style-type: none"> • Transparency lift arm • Transparency lift link Is the transparency sensor assembly installed correctly, not damaged or broken?	Go to step 3	Replace the autocompensator. See “Autocompensat or pick assembly removal” on page 4-17.

Step	Action and questions	Yes	No
3	<p>Check continuity of the paper level sensing cable.</p> <p>Note: This cable is used for both the paper level sensing assembly and the transparency sensor assembly.</p> <p>Is there continuity?</p>	<p>Replace the autocompensator assembly. If this does not correct the problem, replace the engine board. See “Engine board removal” on page 4-29.</p>	<p>Replace the cable</p>

Black only retract (BOR) service check

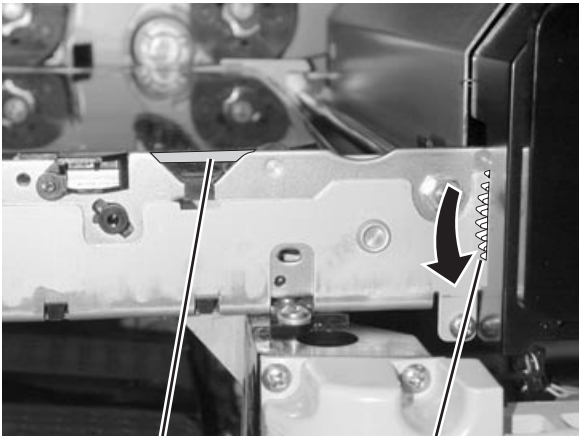
Step	Action and questions	Yes	No
1	<p>Manual check of BOR system—</p> <p>Remove the print cartridges. Observe the ITU belt as you manually rotate the BOR gear.</p>  <p>Belt edge — BOR gear —</p> <p>Does the ITU belt move up and down when the ITU is toggled?</p>	<p>Go to “Entire page is mostly one color—Full bleed planes in one color” on page 2-140.</p>	<p>Go to step 2</p>
2	<p>Remove the ITU. Manually activate the BOR gear. Verify that the front and back BOR cams are moving the respective bell cranks.</p> <p>Do the cams move back and forth properly?</p>	<p>Replace in the following order:</p> <ol style="list-style-type: none"> 1. BOR drive assembly. See “BOR drive assembly removal” on page 4-23. 2. Engine board. See “Engine board removal” on page 4-29. 	<p>Determine which component is preventing the proper movement.</p>

Close door/HVPS/printhead interlock switch service check

Note: There are two separate cables that contain two microswitches and a cable. These cable/switches provide separate interlocks for the printhead and HVPS. One switch in each cable is mounted in the front access door support and the other switch in each cable is mounted on the ITU light shield assembly. The HVPS/cover open cable is connected to J86 on the engine board and the printhead/cover open cable is connected to J12 on the RIP board.

POR incomplete, Close Door constantly displays

This symptom is usually associated with the lower switch mounted on the front access door support and with the left switch mounted in the ITU light shield.

Note: When the printer is powered on for some time with this symptom displayed, the printer may then display a 902 Service Error.

Step	Action and questions	Yes	No
1	Make sure that the ITU light shield is not out of position. Is the ITU light shield out of position?	Properly align the ITU light shield.	Go to step 2
2	Make sure the ITU assembly interlock switch actuator is not damaged or broken and actuates the switches correctly. Is the actuator damaged or broken?	Replace the ITU assembly. See "ITU assembly removal" on page 4-37.	Go to step 3
3	Front cover assembly Does the front cover close correctly?	Go to step 4	Install the front cover correctly or repair as necessary
4	Front cover assembly Make sure the front cover flag is not broken or damaged and actuates the switches correctly. Is the flag broken or damaged?	Replace the front cover assembly. See "Front cover assembly removal" on page 4-10.	Go to step 5
5	Printhead/cover open interlock cable assembly Make sure the cable is correctly connected to J12 on the RIP board. Is the cable connected correctly?	Go to step 6	Install the cable correctly.
6	Make sure the front cover is closed and the ITU is correctly installed. Disconnect J12 from the RIP board and check for continuity between pins J12-1 and J12-3. Do you measure continuity?	Replace the RIP board. See "RIP board removal" on page 4-70.	Replace the printhead interlock cable/switch assembly.

POR complete, printer feeds blank page

This symptom is usually associated with the Upper switch mounted on the Front Access Door Support and with the right switch mounted in the ITU Light Shield.

Step	Action and questions	Yes	No
1	Make sure that the ITU light shield is not broken. Is the ITU light shield broken?	Replace the ITU light shield	Go to step 2
2	Make sure that the ITU light shield is not out of position. Is the ITU light shield out of position?	Properly align ITU light shield	Go to step 3
3	Make sure the ITU assembly interlock switch actuator is not damaged or broken and actuates the switches correctly. Is the actuator damaged or broken?	Replace the ITU assembly. See "ITU assembly removal" on page 4-37	Go to step 4
4	Front cover assembly Does the front cover close correctly?	Go to step 5	Install the front cover correctly or repair as necessary
5	Front cover assembly Make sure the front cover flag is not broken or damaged and actuates the switches correctly. Is the flag broken or damaged?	Replace the front cover. See "Front cover assembly removal" on page 4-10	Go to step 6
6	HVPS/cover open interlock cable assembly to engine board—make sure that the cable is correctly connected to J86 on the engine board. Is the cable connected correctly?	Go to step 7	Install the cable correctly
7	HVPS/cover open interlock cable assembly—make sure the front cover is closed and the ITU is correctly installed. Disconnect the switch cable from J86 on the engine board. Check for continuity between J86-1 and J86-2 on the cable connector. Is there continuity?	Replace the engine board. See "Engine board removal" on page 4-29	Replace the HVPS/cover open interlock switch/cable assembly

Duplex option service check

Before proceeding with this service check:

1. Check for any pieces of media or obstructions in the duplex paper path that might cause a paper jam.
2. Check for correct installation of the front duplex jam tray and right side clearance tray.
3. Check the duplex option for any signs of loose, damaged, contaminated, or warped parts that might cause a jam.

Duplex not recognized as being installed

Step	Action and questions	Yes	No												
1	Is Duplex option the only option installed beneath the base printer?	Go to step 3	Go to step 2												
2	Except for the duplex option, remove any other paper options installed beneath the base printer. Does the printer recognize the duplex option as being installed?	The problem is in one of the option(s) that is installed beneath the printer. Try to isolate which of the options is causing the problem.	Go to step 3												
3	Make sure the duplex option is correctly installed. Is the duplex option installed correctly?	Go to step 4	Install the duplex option correctly												
4	Make sure the bottom options cable connector is snapped firmly into the bottom of the base machine. Is the cable connector mounted correctly?	Go to step 5	Install the cable correctly												
5	Make sure the options cable is installed correctly to engine board connector J5. Is the cable installed correctly?	Go to step 6	Install the cable correctly												
6	Check the voltages on connector J5 on the engine board. The voltages are measured with the printer in standby mode: Note: All voltages are approximate values. <table border="1" data-bbox="380 1314 652 1524"> <thead> <tr> <th>Connector pin</th> <th>Voltage</th> </tr> </thead> <tbody> <tr> <td>J5-1</td> <td>+24 V dc</td> </tr> <tr> <td>J5-3</td> <td>+5 V dc</td> </tr> <tr> <td>J5-5</td> <td>+5 V dc</td> </tr> <tr> <td>J5-6</td> <td>+5 V dc</td> </tr> <tr> <td>J5-8</td> <td>+5 V dc</td> </tr> </tbody> </table> Are the voltages correct?	Connector pin	Voltage	J5-1	+24 V dc	J5-3	+5 V dc	J5-5	+5 V dc	J5-6	+5 V dc	J5-8	+5 V dc	Go to step 7	Replace the engine board. See “Engine board removal” on page 4-29.
Connector pin	Voltage														
J5-1	+24 V dc														
J5-3	+5 V dc														
J5-5	+5 V dc														
J5-6	+5 V dc														
J5-8	+5 V dc														

Step	Action and questions	Yes	No												
7	<p>Check the voltages on the bottom options cable connector. The voltages are with the printer in standby mode.</p> <p>Note: All voltages are approximate values.</p> <table border="1"> <thead> <tr> <th>Connector pin</th> <th>Voltage</th> </tr> </thead> <tbody> <tr> <td>J5-1</td> <td>+24 V dc</td> </tr> <tr> <td>J5-3</td> <td>+5 V dc</td> </tr> <tr> <td>J5-5</td> <td>+5 V dc</td> </tr> <tr> <td>J5-6</td> <td>+5 V dc</td> </tr> <tr> <td>J5-8</td> <td>+5 V dc</td> </tr> </tbody> </table> <p>Are the voltages correct?</p>	Connector pin	Voltage	J5-1	+24 V dc	J5-3	+5 V dc	J5-5	+5 V dc	J5-6	+5 V dc	J5-8	+5 V dc	Go to step 8	Replace the bottom options cable in the printer
Connector pin	Voltage														
J5-1	+24 V dc														
J5-3	+5 V dc														
J5-5	+5 V dc														
J5-6	+5 V dc														
J5-8	+5 V dc														
8	<p>Make sure the upper options cable in the duplex option is installed correctly in the duplex frame.</p> <p>Is the cable installed correctly?</p>	Go to step 9	Correctly install the cable. If the connector is damaged, replace the cable assembly.												
9	<p>Make sure the upper options cable in the duplex option is connected correctly to J11 on the duplex options board.</p> <p>Is the cable connected correctly?</p>	Go to step 10	Install the cable correctly												
10	<p>Check continuity of the upper duplex options cable.</p> <p>Is there continuity?</p>	Replace the duplex options board.	Install the cable correctly.												

Top margin on duplexed copy set incorrectly

Go to **“Quick Test” on page 3-23** to adjust the top margin on the back of the duplex page.

Finisher service check

If a failure is detected by the system board, an error may be displayed. The LEDs on the HCOF system board can help in diagnosing the errors

HCOF error code table

LEDs lit by number								Description
33	34	35	36	37	38	39	42	
							x	Error detected by punch timing sensor
						x		Error detected by inverter jam sensor
						x	x	Error detected by drop timing sensor
					x			Error detected by exit timing sensor
					x		x	Error detected for the jogger motor
					x	x		Error detected for the punch motor
					x	x	x	Error detected for the stapler motor
				x				Error detected for the belt motor
				x			x	Error detected for the tray motor
				x		x		HCOF detects the front door is open
				x		x	x	Error detected with the communications to the printer
				x	x			Error detected for the offset motor
				x	x	x		Tray Near Full is detected
				x	x	x	x	Tray Full is detected
			x					Error detected with stapler—stapler not mounted correctly
			x				x	Error detected with stapler—stapler cartridge not installed correctly
			x			x		Error detected with stapler—runs short
			x			x	x	Error detected with punch timing sensor—media not reaching sensor
			x		x			Error detected with inverter jam sensor—media not reaching sensor
			x		x		x	Error detected with drop timing sensor—media not reaching sensor
			x		x	x		Error detected with exit timing sensor—media not reaching sensor
			x		x	x	x	Error detected with chad box—Box Full

Check Finisher displayed, unable to clear message

Step	Action and questions	Yes	No
1	Check for correct printer and finisher installation. Make sure the magnetic bracket is mounted on the printer. Is the magnetic bracket mounted on the printer?	Go to step 2	If not installed, install the bracket
2	Is the pin on the magnetic bracket actuating the joint switch in the finisher?	Go to step 3	Find out why the pin is not actuating the switch and repair as necessary.
3	Check the joint switch cable connection to CN19 on the finisher system board. Is the cable installed correctly?	Go to step 4	Install the cable correctly
4	Check the joint switch activating spring for any signs of damage. Is the switch activating spring broken?	Replace the joint switch assembly	Go to step 5
5	Check the joint switch for correct operation. The switch can be checked by measuring continuity while actuating the switch. Is the switch operating correctly?	Go to step 6	Replace the joint switch assembly.
6	Check continuity of the joint switch cable. Is there continuity?	Replace the finisher system board.	Replace the cable.



Finisher is totally inoperative, no motor movement, no LEDs on

This problem can be caused by a problem with the autoconnect system between the finisher and the printer. It also can be caused by a problem with the power system in the finisher.

Step	Action and questions	Yes	No
1	Check the AC line cord to the finisher to make sure the options and printer are connected properly. Are the printer and options AC line cords connected properly?	Go to step 2	Connect the printer and options correctly
2	Make sure the communications cable from the finisher to the printer is installed correctly at the output options autoconnect on the printer. Is the cable installed correctly?	Go to step 3	Install the cable correctly.
3	Disconnect the autoconnect cable from J7 on the engine board. Check the resistance between J7-6 and J7-7 on the cable connector. The resistance measures between 45 ohms and 50 ohms. Is the resistance correct?	Go to step 6	Go to step 4

Step	Action and questions	Yes	No
4	<p>Make sure the communications cable is connected properly to CN3 on the LVPS Relay board.</p> <p>Is the cable installed correctly?</p> <p>Note: The relay on the relay board is connected to +5 V dc from the printer through the communications cable. When the printer is powered on, +5 V dc is sent to the finisher relay board relay coil which energizes the relay and connects primary AC line voltage to the LVPS.</p>	Go to step 5	Install the cable correctly.
5	<p>Check the resistance of the relay coil by measuring between CN3-1 and CN3-2 on the relay board. The resistance measures between 45 ohms and 50 ohms.</p> <p>Is the resistance correct?</p>	Replace the communication cable.	Replace the relay board/LVPS assembly.
6	<p>Check the voltage on the output options Autoconnect connector Pin 2 located on the top right rear of the printer. The voltage measures approximately +5 V dc.</p> <p>Is the voltage correct?</p>	Go to step 7	Go to step 10
7	<p>Check the AC line voltage between CN2-1 and CN2-3 on the relay board. The line voltage should be within specifications for the AC power source the printer is connected to.</p> <p>Is there line voltage at CN2?</p>	Replace the LVPS assembly.	Go to step 8
8	<p>Check the AC line voltage between CN1-1 and CN1-5 on the relay board. The line voltage should be within specifications for the AC power source the printer is connected to.</p> <p>Is there line voltage at CN1?</p>	Replace the relay board assembly.	Go to step 9
9	<p>Check continuity of the AC line cord.</p> <p>Is there continuity?</p>	Go to step 10	Replace the line cord
10	<p>Check the voltage at J7-5 on the engine board. The voltage measures approximately +5 V dc.</p> <p>Is the voltage correct?</p>	Replace the top options cable	Replace the engine board

Front door is open, no indication on display

Step	Action and questions	Yes	No
1	Make sure the front door is activating the cover switch. Is the door activating the cover switch?	Go to step 2	Repair or replace the door assembly.
2	Check door—door switch activating tab (broken or missing). Is the front door and door activating tab damaged, broken or missing?	Replace the front door assembly.	Go to step 3
3	Check the front door magnetic latches to make sure the front door closes correctly. Are the magnetic latches functioning properly?	Go to step 4	Replace the magnetic latches.
4	Check the front door switch cable connection to CN11 on the finisher system board. Is the cable connected correctly?	Go to step 5	Install the cable correctly.
5	Check the continuity of the front switch as the switch is activated. Do you measure continuity?	Go to step 6	Replace the front door switch.
6	Check continuity of the front door switch cable. Do you measure continuity?	Replace the finisher system board.	Replace the front door switch cable D1.

Fan in finisher inoperative

Step	Action and questions	Yes	No
1	Make sure the fan cable, H6, is correctly connected to CN21 on the finisher system board. Is the cable connected correctly?	Go to step 2	Install the cable correctly.
2	Check the cable H6 connection to the fan assembly. Is the cable connected correctly?	Go to step 3	Install the cable correctly.
3	Check the voltage between CN21-1 and CN21-2. The voltage measures approximately +24 V dc. Is the voltage correct?	Go to step 4	Replace the finisher system board.
4	Check continuity of the fan cable H6. Do you measure continuity?	Replace the fan assembly.	Replace cable H6.

No indication that the chad box is full, no message

Use the **“HCOF error code table” on page 2-122** to help diagnose the problem.

Step	Action and questions	Yes	No												
1	Make sure the chad box is correctly installed in the finisher. Is the chad box correctly installed.	Go to step 2	Install the chad box correctly.												
2	Make sure the chad box cable S5 is properly connected to CN5 on the finisher system board. Is the cable properly connected?	Go to step 3	Install the cable correctly.												
3	Make sure the chad box cable is properly connected to the chad box sensor located above the box. Is the cable properly connected to the sensor?	Go to step 4	Install the cable correctly.												
4	Check the chad box sensor with a voltmeter. Empty the chad box. Check the voltages on CN5. The voltages read the following approximate values with the chad box empty: <table border="1" data-bbox="381 821 842 957"> <thead> <tr> <th>Connector pin</th> <th>Voltage</th> <th></th> </tr> </thead> <tbody> <tr> <td>CN5-1</td> <td>+5 V dc</td> <td>+5 V dc supply</td> </tr> <tr> <td>CN5-2</td> <td>+5 V dc</td> <td>sensor signal</td> </tr> <tr> <td>CN5-3</td> <td>0 V dc</td> <td>Ground</td> </tr> </tbody> </table> Are the voltages correct?	Connector pin	Voltage		CN5-1	+5 V dc	+5 V dc supply	CN5-2	+5 V dc	sensor signal	CN5-3	0 V dc	Ground	Go to step 5	Replace the finisher system board.
Connector pin	Voltage														
CN5-1	+5 V dc	+5 V dc supply													
CN5-2	+5 V dc	sensor signal													
CN5-3	0 V dc	Ground													
5	Check the sensor by placing the chad box or a piece of paper in front of the sensor. As the chad box or piece of paper is moved away from the front of the sensor the voltage on CN5-2 should change from +5 V dc to 0 V dc. Does the voltage change?	Problem solved	Replace the chad box sensor.												

Chad box full message when chad box is not full

Step	Action and questions	Yes	No
1	Make sure the chad box is correctly installed in the finisher. Is the chad box correctly installed?	Go to step 2	Install the chad box correctly.
2	Check the chad box sensor with a voltmeter. Empty any material that is in the chad box. Measure the voltage on CN5-2. The voltage changes from approximately +5 V dc to 0 V dc as the sensor is activated. Does the voltage change?	The sensor is working correctly.	Replace the finisher system board.

Fuser service check

Cold fuser service

If error code 122, 123, 126, 127, 128, 129, 130, 131, 132, or 133 is displayed, the printer detects a problem in the fuser hot roll or back up roll fuser lamp circuits, fuser hot roll thermistor, back up roll thermistor, engine board or LVPS fuser control circuits.

Hot fuser service

Error codes 124, 125, 134, and 135 appear whenever the printer detects a problem with the fuser running over temperature or the fuser lamps have been on too long.

Excessive fuser drive motor assembly noise

Step	Action and questions	Yes	No
1	Excessive noise from the fuser drive motor assembly— check for correct installation of the fuser drive motor assembly. Is the fuser drive motor installed correctly?	Go to step 2	Correctly install the fuser drive assembly. See “Fuser drive assembly removal” on page 4-33.
2	Install a new fuser top duct. See “Fuser top duct removal” on page 4-34. Is there still excessive noise from the fuser drive motor assembly?	Replace the fuser drive assembly. See “Fuser drive assembly removal” on page 4-33.	Replace the fuser top duct. See “Fuser top duct removal” on page 4-34.

High-capacity input tray (HCIT) 2000-sheet option service check

HCIT system board LED error code table

If a failure is detected by the system board, an error code may be displayed. If the system board LED is on solid, the HCIT detects that the tray or side door is not closed.

The LED on the system board may blink. Count the number of times the LED blinks and use the following table to determine the problem.

LED blinks	Problem
1	Jam at registration sensor S2
2	Jam before the leading edge of the paper reaches the registration sensor S2
3	Paper jam is still detected in the HCIT after removing the jam
4	Paper jam is still detected even with front of jam door closed
5	Paper jam detected at pick sensor
6	Error detected with the tray
7	Error detected at the registration roller home position
8	Error detected at the pick roller home position sensor (S1)
9	Error detected with the lift motor—no motor lock or loss of lock
10	Not used
11	Communication error
12	Other error—failure of the adjustment of the mirror reflection sensors or EEPROM initialization

Printer does not recognize that the HCIT 2000-sheet option is installed.

Step	Action and questions	Yes	No
1	Is the HCIT 2000-sheet option the only paper input option that is not recognized?	Go to step 5	Go to step 2
2	Make sure that the printer and any option above the HCIT 2000-sheet option are installed correctly. Are the printer and any options installed correctly?	Go to step 3	Install the options correctly and recheck performance
3	Check for correct installation of the lower options autoconnect cable to engine board connector J5. Is the cable to J5 installed correctly?	Go to step 4	Install the cable correctly and recheck performance

Step	Action and questions	Yes	No												
4	<p>Disconnect J5 from the engine board and check the voltages on connector J5 on the engine board.</p> <p>The voltages measure as follows:</p> <p>Note: All voltages are approximate values.</p> <table border="1" data-bbox="435 394 704 604"> <thead> <tr> <th>Connector pin</th> <th>Voltage</th> </tr> </thead> <tbody> <tr> <td>J5-1</td> <td>+24 V dc</td> </tr> <tr> <td>J5-3</td> <td>+5 V dc</td> </tr> <tr> <td>J5-5</td> <td>+5 V dc</td> </tr> <tr> <td>J5-6</td> <td>+5 V dc</td> </tr> <tr> <td>J5-8</td> <td>+5 V dc</td> </tr> </tbody> </table> <p>Are the voltages correct?</p>	Connector pin	Voltage	J5-1	+24 V dc	J5-3	+5 V dc	J5-5	+5 V dc	J5-6	+5 V dc	J5-8	+5 V dc	Go to step 5	Replace the engine board
Connector pin	Voltage														
J5-1	+24 V dc														
J5-3	+5 V dc														
J5-5	+5 V dc														
J5-6	+5 V dc														
J5-8	+5 V dc														
5	<p>Autoconnect cables—check the autoconnect from the printer or option above the HCIT 2000-sheet option. Check for any signs of cuts, pinched wiring or damage to the contacts in the connector.</p> <p>Are there any problems with the autoconnect cables?</p>	Repair or replace as necessary	Go to step 6												
6	<p>HCIT autoconnect cable—check the HCIT autoconnect cable for correct installation at the HCIT system board.</p> <p>Is the cable installed correctly?</p>	Go to step 7	Install the cable correctly												
7	<p>HCIT autoconnect cable continuity—check the continuity of the HCIT autoconnect cable(s).</p> <p>Is there continuity?</p>	Replace HCIT system board	Replace the HCIT autoconnect cable												



HCIT inoperative

Before proceeding with this service check make sure the 2000-sheet tray option is properly connected to AC power.

- If a finisher is installed:
- The AC jumper should go from the HCIT to the finisher. The finisher AC power cord should attach to the AC voltage source. The base printer power cord should plug into the AC output connector on the HCIT.
- If a finisher is not installed:

The printer power cord plugs into the HCIT AC outlet and the power cord from the HCIT plugs into the AC voltage source.

Note: Make sure the electrical outlet is working properly and all power cords are plugged in correctly. Make sure the slide switch on the LVPS is toward the right.

The system board status LED can be observed by removing the rear cover. The LED is mounted on the HCIT system board.

Step	Action and questions	Yes	No
1	Does the printer power up and work normally when plugged into the AC outlet on the HCIT?	Go to step 2	Go to step 5
2	Check the system board LED. Is it is on solid or blinking? <ul style="list-style-type: none"> • On solid means that the HCIT has detected the front door or side door open. • Blinking means that the system is operating. Is the LED on solid or blinking?	If the LED is on solid, check the front and side doors. If the LED is blinking, replace the HCIT system board	Go to step 3
3	Measure the voltage at TP3 (+5 V dc test point) on the HCIT system board. The voltage should measure approximately +5 V dc. Is the voltage correct?	Replace the HCIT system board	Go to step 4
4	Measure the voltage at CN2 pin 2 on the HCIT system board. The voltage should measure approximately +5 V dc. Is the voltage correct?	Replace the HCIT system board	Go to step 5
5	Check the AC line voltage at the input to the LVPS. Is the voltage correct?	Replace the HCIT LVPS	Go to step 6
6	Check the AC cable from the HCIT AC inlet to the LVPS. Are the cables good?	Determine where the AC line voltage is being lost to the HCIT. Repair as necessary.	Replace the cables

HCIT 2000-sheet Option does not recognize the size paper selected.

Step	Action and questions	Yes	No
1	Make sure the media loaded in the tray meets specifications. Is the media loaded properly and meet specifications?	Go to step 2	Load the media properly or inform the customer that the media does not meet specifications
2	Check the paper tray guide for correct installation. Is the paper tray guide installed correctly for the selected paper size?	Go to step 3	Reinstall the guide if installed incorrectly
3	Check for correct installation of the paper size sensor cable to the HCIT system board at CN7. Is the cable installed correctly?	Go to step 4	Install the cable correctly.
4	Check for a broken, loose, or missing paper size sensor flag spring. Is a sensor flag spring broken, loose, or missing?	Reconnect the spring if it is loose. Replace the spring if broken or missing.	Go to step 5
5	Check the paper size sensor flag for sticking or broken parts. Is the paper size sensor flag sticking or broken?	Replace the paper size flag	Go to step 6
6	Check continuity of the sensor cable. Do you measure continuity?	Replace the sensor. If this does not fix the problem, replace the HCIT system board.	Replace the sensor cable

Operator panel LCD/status LED/buttons service check

Use this service check to check both the operation of the panel buttons and to test the LCD display for correct operation.

- Replace the operator panel assembly if the LCD display functions normally, but the LED does not come on.
- If one or more of the operator panel buttons do not operate correctly, go to “Step A.”

If any of the following symptoms occur, go to **“Step B” on page 2-132.**

- Operator panel LCD is blank/Power On/Status LED off
- Operator panel LCD is blank/Power On/Status LED on
- Operator panel LCD displays all diamonds/5 beeps/Power On/Status LED on

Step A

Step	Action and questions	Yes	No
1	Buttons Test—perform the “Button Test” on page 3-19. Do any or all of the Buttons fail to operate correctly? Note: If all the buttons fail to operate correctly, the LCD display is blank, Power On Status LED is on, and the printer beeps 5 times, go step B.	Replace the operator panel. See “Operator panel removal” on page 4-46	Test passes. No problem found

Step B

Note: Make sure the operator panel cable is seated firmly in J1 on the RIP board before proceeding with this step.

Step	Action and questions	Yes	No
1	LCD Test—perform the “LCD Test” on page 3-19. Can you run the test?	Go to step 2	Go to step 4
2	LCD Test—does the test pass?	Problem solved	Go to step 3
3	Operator panel—is the operator panel operating correctly except for a few pels missing or broken?	Replace the operator panel. See “Operator panel removal” on page 4-46	Go to step 4
4	Operator panel assembly—is the operator panel assembly completely blank and the power on status LED off?	Go to step 6	Go to step 5
5	Operator panel assembly—is the operator panel assembly completely blank and the power on status LED on?	Go to step 10	Go to step 12
6	Does the printer beep 5 times?	Go to step 7	Replace the operator panel. See “Operator panel removal” on page 4-46

Step	Action and questions	Yes	No																		
7	RIP board—measure the voltage at connector J1-2 on the RIP board. See “RIP board” on page 5-14 . The voltage measures approximately +5 V dc. Is the voltage correct?	Replace the operator panel. See “Operator panel removal” on page 4-46	Go to step 8																		
8	Operator panel cable (operator panel connection)—make sure the operator panel cable is seated correctly in the connector on the operator panel board. Is the cable seated correctly?	Go to step 9	Seat the cable correctly																		
9	Operator panel cable—check continuity of the operator panel cable. Is there continuity?	Replace the RIP board. See “RIP board removal” on page 4-70	Go to “Operator panel removal” on page 4-46 and replace the operator panel cable																		
10	RIP board—a poor ground connection between pin 4 on the operator panel board connector can cause this symptom. Check for continuity between Pin J1-4 and ground on the board. See “RIP board” on page 5-14 . Is there continuity?	Go to step 11	Replace the RIP board. See “RIP board removal” on page 4-70																		
11	Operator panel cable—check continuity of the operator panel cable. Is there continuity?	Replace the operator panel. See “Operator panel removal” on page 4-46	Go to “Operator panel removal” on page 4-46 and replace the operator panel cable																		
12	Operator panel assembly—does the operator panel display all diamonds, with the power on/status LED on and 5 beeps?	Go to step 13	Call your next level support																		
13	Voltage checks at RIP connector J1. See “RIP board” on page 5-14 . Check the voltages on RIP connector J1 as shown: <table border="1" data-bbox="428 1220 974 1446"> <thead> <tr> <th>Pin</th> <th>Voltage (display static)</th> <th>Voltage (display active—LCD Test running)</th> </tr> </thead> <tbody> <tr> <td>J1-1</td> <td>+5 V dc</td> <td>Voltage varies 1.0 to 2.0 V dc</td> </tr> <tr> <td>J1-2</td> <td>+5 V dc</td> <td>+5 V dc</td> </tr> <tr> <td>J1-3</td> <td>+5 V dc</td> <td>Voltage varies 1.0 to 2.4 V dc</td> </tr> <tr> <td>J1-4</td> <td>Ground</td> <td>Ground</td> </tr> <tr> <td>J1-5</td> <td>+5 V dc</td> <td>+5 V dc</td> </tr> </tbody> </table> Are the voltages correct?	Pin	Voltage (display static)	Voltage (display active—LCD Test running)	J1-1	+5 V dc	Voltage varies 1.0 to 2.0 V dc	J1-2	+5 V dc	+5 V dc	J1-3	+5 V dc	Voltage varies 1.0 to 2.4 V dc	J1-4	Ground	Ground	J1-5	+5 V dc	+5 V dc	Replace the operator panel. See “Operator panel removal” on page 4-46	Go to step 14
Pin	Voltage (display static)	Voltage (display active—LCD Test running)																			
J1-1	+5 V dc	Voltage varies 1.0 to 2.0 V dc																			
J1-2	+5 V dc	+5 V dc																			
J1-3	+5 V dc	Voltage varies 1.0 to 2.4 V dc																			
J1-4	Ground	Ground																			
J1-5	+5 V dc	+5 V dc																			
14	Operator panel cable—check continuity of the operator panel cable. Is there continuity?	Replace the operator panel. See “Operator panel removal” on page 4-46	Go to “Operator panel removal” on page 4-46 and replace the operator panel cable																		

Output Expander option service check

Note: The majority of the mechanical components can be observed during operation by removing the covers. The output expander functions without the covers installed. Make sure the option is correctly installed before attempting to service the unit.

Step	Symptoms	Yes	No
1	The printer does not recognize one or more output expander options as being installed.	Go to “Printer does not recognize that one or more output options as being installed.” on page 2-135	Go to step 2
2	202 Paper Jam Open Rear Door appears. A sheet of paper is jammed prior to the pass thru sensor flag or a sheet of paper feeds out to the standard bin even though bin x is selected. Paper exits half way out of the redrive.	Go to “Output expander” on page 2-75	Go to step 3
3	Remove paper - Output Bin x is displayed, POST is incomplete, unable to clear the message.	Go to “Remove paper - Output Bin x displays, POST is incomplete, unable to clear the message.” on page 2-136	Go to step 4
4	271 Paper Jam - Check Bin x appears, POST incomplete.	Go to “271 Paper jam - Check Bin 1” on page 2-84	Go to step 5
5	271 Paper Jam - Check Bin x appears, POST complete, first sheet of paper feeds into Output Bin x.	Go to “Output Expander, POST complete—First sheet of paper feeds into Output Bin 1” on page 2-84	Go to step 6
6	No indication that bin x is full OR no indication that bin x is near full.	Go to “No indication that Bin x is full or no indication that Bin x is near full.” on page 2-135	Go to step 7
7	990 Service - bin x	Go to “990 Service error” on page 2-101	Call your next level support

No indication that Bin x is full or no indication that Bin x is near full.

Step	Actions and questions	Yes	No
1	Sensor cable installation—check for correct installation of the sensor cable at J5 on the control board. Is the cable installed correctly?	Go to step 2	Install the cable correctly
2	Dual output bin x sensor assembly Do either the bin x full or the bin x near full sensor fail the sensor test?	Go to step 3	Call your next level support
3	Voltage—check the voltages at J5-3 and J5-4. The voltages should measure approximately +5 V dc. Are the voltages correct?	Replace the sensor	Replace the control board

Printer does not recognize that one or more output options as being installed.

Step	Actions and questions	Yes	No
1	Excessive static electricity buildup—check the output expander control board cover to make sure the ESD brush ground lead is firmly attached to the output expander frame. Make sure the ESD is loose not or damaged. Is the ESD brush ground cable correctly installed and the ESD brush not loose or broken?	Go to step 2	1. Attach the ground cable if not installed correctly. 2. Replace the cover assembly if the ESD brush is loose or damaged.
2	Options check—If more than a single output expander option is installed, check each one to see if the printer recognizes any single option as being installed. If the printer recognizes any of the output expander options then the base printer autoconnect system is operating correctly and the problem is in the unrecognized expander option. Make sure that the output expander option is the only output option that is not recognized by the base printer. Is this the only output option not recognized by the base printer?	Go to step 3	Go to the autoconnect system on the Output Expander option, base printer and check cables and connections to the engine board
3	Output Expander assembly mechanical linkage (cables)—Check the output expander autoconnect cable and connector for any signs of damage, especially the connector pins. Is there any signs of damage to the cable, connector, or connector pins?	Replace the autoconnect cable	Go to step 4
4	Output Expander assembly mechanical linkage (electrical) Check the cables at J1A, J1B, J2A and J2B on the control board to make sure they are attached securely and correctly. Are the cables attached securely and correctly?	Go to step 5	Reseat the cables
5	Voltage check, base printer autoconnect connector—turn the power off and remove the output expander option from the printer and check the voltages on the base printer top autoconnect connector. Go to Autoconnect - Top. Are the voltages correct?	Go to step 6	The problem is in the base printer. Check autoconnects in the printer.

Step	Actions and questions	Yes	No
6	Voltage check—output expander system board— Reinstall the output expander option and check the voltages at J1A and J1B on the connector. Are the voltages correct?	Replace the Output Expander option system board	Replace the Output Expander option mechanical linkage assembly

Remove paper - Output Bin x displays, POST is incomplete, unable to clear the message.

Step	Actions and questions	Yes	No
1	Output sensor flag check—check the flag for correct operation, binds, broken parts, or interference from the sensor cable. Is there a problem with the sensor flag?	Replace the flag or repair as necessary	Go to step 2
2	Output bin sensor—run the sensor test to check the output bin sensor for correct operation. Does the sensor operate correctly?	Call your next level support	Replace the sensor assembly. If this does not fix the problem replace the engine board. See “Engine board removal” on page 4-29.

Print quality service checks

Note: This symptom may require replacement of one or more CRUs (Customer Replaceable Units) designated as supplies or maintenance items, which are the responsibility of the customer. With the customer's permission, you may need to install an ITM, fuser assembly, second transfer roll, or print cartridge.

Check the following before proceeding with any of the print quality service checks.

- Use Tray 1 (internal tray) to test the print quality of the base printer.
- Be sure the fuser assembly is installed correctly.
- Be sure the ITU assembly is installed correctly.
- Be sure the Second Transfer Roll is installed correctly.
- Check the media in Tray 1 to make sure it meets paper specifications.
- Run a copy of the CE Test page, this sets all the printer defaults to the correct settings to check for print quality.
- If a specific color has a print quality problem, first try a new cartridge to help isolate the problem.

An incorrect printer driver for the installed software, can cause print quality problems. Incorrect characters could print and the copy may not fit the page correctly.

Note: Some 201 Paper Jam errors can be caused by a faulty print cartridge.

Horizontal line

- Go to step 1 if there is a horizontal black line only.
- Go to step 2 if there is a cyan, magenta or yellow horizontal line.

Step	Action and questions	Yes	No
1	Black print cartridge—the most likely cause of this failure is a failing black print cartridge where the PC drum is shorting to the charge roll inside the print cartridge. Try a new black print cartridge. Does this fix the problem?	Replace the cartridge	Call your next level support
2	Cyan print cartridge check—enter the Diagnostics Mode. Remove the cyan print cartridge and run the print test. Does the problem still exist for the remaining cartridges?	Go to step 3	Replace the failing cartridge
3	Magenta print cartridge check—enter the Diagnostics Mode. Remove the magenta print cartridge and run the print test. Does the problem still exist for the remaining cartridges?	Replace the yellow print cartridge	Replace the magenta print cartridge

Horizontal lines or streaks

Is the horizontal marks or lines repeat at evenly-spaced intervals, use the **“Print quality defect locator chart” on page 3-3** to determine the part to be replaced.

For lines or marks appearing a random intervals, go to step 1.

Step	Action and questions	Yes	No
1	Are the horizontal marks or lines in a single color?	Replace the cartridge.	Go to step 2
2	Print cartridge(s) - Enter the Diagnostics Mode. Remove one print cartridge at a time and run a Test Page to isolate the faulty print cartridge. Have you isolated the failing print cartridge?	Replace the cartridge contact assembly. See “Cartridge contact assembly removal” on page 4-23.	Go to step 3
3	Reseat the ITU. Do the marks/lines persist?	Go to step 4	Problem solved
4	Does the printer display an 83 ITU Maintenance message?	Recommend the customer order the ITU maintenance kit. See “Scheduled maintenance” on page 6-4.	Replace the ITU assembly. See “ITU assembly removal” on page 4-37.

Vertical lines or streaks

Step	Action and questions	Yes	No
1	Are the vertical streaks visible outside the printed image?	Go to step 2	Replace the cartridge.
2	Are the vertical streaks in a single color?	Go to step 3	Replace the ITU assembly. See "ITU assembly removal" on page 4-37.
3	Vertical streaks in a single color, which are visible outside the printed, are most likely caused by a cleaner problem in the print cartridge. Are streaks magenta, cyan, or yellow	Replace the cartridge.	Replace in order: <ul style="list-style-type: none"> • Black print cartridge • ITU assembly. See "ITU assembly removal" on page 4-37.

Light lines or streaks appear on the page

Single color streaks outside the printed page are most likely caused by a problem in the print cartridge. Replace the print cartridge.

All the colors streaking at a different spot on each page is probably caused by a damaged ITU assembly. Replace the ITU assembly. See **"ITU assembly removal" on page 4-37.**

If only one color streaks in the printed area, go to step 1.

Step	Action and questions	Yes	No
1	Print cartridge check - Try a new print cartridge. Does a new print cartridge fix the problem?	Problem solved	Go to step 2
2	Printhead check -The printhead lens may be contaminated by toner. Check for any signs of contamination on the lens of the printhead. Is the printhead contaminated?	Go to Clear the printhead lens with a soft, lint-free cloth.	Call your next level support

White streak in color plane

A white streak appears in one particular color plane. This problem may be caused by a contaminated developer roll in the print cartridge.

Step	Action and questions	Yes	No
1	Check to see which color is having the problem and go to step 2.		
2	If another cartridge is available, try a new cartridge for the color having the problem. Do you have another cartridge to try?	Go to step 3	Go to step 4.
3	Does a new cartridge fix the problem?	Problem solved	Go to step 5

Step	Action and questions	Yes	No
4	If another cartridge is not available, break the corresponding tabs off the cartridge in question as well as an adjacent color. The tabs are used to ensure that the cartridge is installed in the correct color station. Switch the two cartridges and print out a print sample to see if the streak stays with the cartridge and not the station. Does the streak change when you switch cartridges?	Replace the defective cartridge.	Go to step 5
5	Printhead check -The printhead lens may be contaminated by toner. Check for any signs of contamination on the lens of the printhead. Is the printhead contaminated?	Go to “Printhead removal and adjustment” on page 4-50	Call your next level support

Blank page (no image)

- If there is no image (blank page) and no error codes displayed, go to step 1.
- If there is no image (blank page) but error codes are displayed, go to **“Sub error code table” on page 2-17** and perform the necessary action.

Step	Action and questions	Yes	No
1	Second transfer roll—make sure the second transfer roll is installed and correctly installed. Is the second transfer roll correctly installed?	If a second transfer roll is not installed, install a new one.	Go to step 2
2	Second transfer roll release lever—make sure the second transfer roll release lever is not stuck in the down position. Check for broken or damaged parts. Is the second transfer roll release lever operating correctly?	Go to step 3	Repair as necessary
3	Check continuity of the second transfer roll to the transfer HVPS cable. Is there continuity?	Replace the transfer HVPS board. See “Transfer HVPS board removal” on page 4-80	Replace the cable

Entire page is mostly one color—Full bleed planes in one color

Some printing may appear in other colors. This applies to black, cyan, magenta and yellow.

Step	Action and questions	Yes	No
1	Using a piece of paper, block the laser path between the printhead and cartridge for the color that is experiencing the full bleed issue.	Go to step 2	Go to step 4
2	Turn the printer off. Check the cable connections between the printhead and the system board. Do you continue to have the same problem?	Go to step 3	Problem solved
3	Use the “Printhead diagnostics” on page 3-1 and the “Card assembly, printhead diagnostic aid” on page 7-15 to switch video cables between the printhead of the full bleed color and another color. Does the color of the full bleed plane stay the same?	Replace the printhead (see “Printhead removal and adjustment” on page 4-50.)	Replace the system board. See “System board” on page 4-80.
4	Change or switch the cartridge of the color that is experiencing the issue. Do you continue to have the same problem?	Go to step 5	Replace the cartridge.
5	Cartridge contact assembly - Check the cartridge contact block. Make sure the PC drum contact pin is not stuck. See “Cartridge contact assembly pin locations” on page 5-4 to identify the PC drum contact pin. Does the pin operate correctly?	Go to step 6	Replace the cartridge contact assembly. See “Cartridge contact assembly removal” on page 4-23.
6	Turn the printer off. Check the cable connections between the developer HVPS board and the system board. Do you continue to have the same problem?	Go to step 7	Problem resolved
7	Perform a continuity check on the developer HVPS cable. Do you have continuity?	Replace the FRUs in the following order: 1. “Developer HVPS board removal” on page 4-28. 2. “Engine board removal” on page 4-29.	Replace the developer HVPS cable.

Missing colors—Complete or partially missing color planes

- If a color or colors are missing, or a color is partially missing, go to **“Step A” on page 2-143.**
- If cyan, magenta, and yellow is missing, go to **“Black and white only—cyan, magenta, and yellow are missing” on page 2-142.**

Step	Action and questions	Yes	No
1	Print cartridge - Make sure the cartridge is seated properly and that all packing material has been removed from the cartridge. Has all packing material been removed? Is the cartridge seated correctly?	Go to step 2	Remove packaging and seat cartridge
2	Inspect each of the transfer roll bellcranks. Were any of the bellcranks broken?	Replace the broken bell cranks.	Go to step 3
3	Perform the partial print test. See “Partial Print Test” on page 3-5. Is the image well developed on the PC drum but the same plane is missing or faded on the ITU belt?	Go to step 4	Go to step 6
4	Turn off the printer. Check the cable connections between the transfer HVPS board and the system board. Do you continue to have the same problem?	Go to step 5	Problem resolved
5	Check continuity on the cable between the respective rear bellcrank and the lead on the transfer HVPS board. Is there continuity?	Replace in the following order: 1. “Transfer HVPS board removal” on page 4-80 2. “Cartridge contact assembly removal” on page 4-23 3. “Engine board removal” on page 4-29.	Replace the FRUs in the following order: 1. Cable 2. FTR spring.
6	Change or switch failing cartridge. Do you continue to have the same problem?	Go to step 7	Replace the cartridge.
7	Cartridge contact assembly - Check the cartridge contact block. Make sure the PC drum contact pin is not stuck. See “Cartridge contact assembly removal” on page 4-23 to identify the PC drum contact pin. Does the pin operate correctly?	Go to step 8	Replace the “Cartridge contact assembly removal” on page 4-23.

Step	Action and questions	Yes	No
8	Perform a continuity check on the developer HVPS cable. Is there continuity?	Replace in order: 1. Developer HVPS board. See “Developer HVPS board removal” on page 4-28. 2. Engine board. See “Engine board removal” on page 4-29.	Replace the developer HVPS cable.

Black and white only—cyan, magenta, and yellow are missing

Step	Action and questions	Yes	No
1	Check the Print Mode setting in the Color Menu. Is the Print Mode set to Black&White ?	Change the setting to Color .	Go to step 2
2	Ask the user or network administrator to check if the correct color driver is installed. Is the correct color driver installed?	Install the correct color driver.	Go to “Black only retract (BOR) service check” on page 2-117.

Light print over the entire page

- If all colors have light print, go to **“All colors have light print over the entire page” on page 2-142.**
- If only one color has light print, go to **“One color has light print over the entire page” on page 2-143.**

All colors have light print over the entire page

Step	Action and questions	Yes	No
1	Replace the second transfer roll. See “Second transfer roll removal” on page 4-79. Does the light print persist?	Go to step 2	Problem resolved
2	Turn the printer off. Check the cable connections between the transfer HVPS board and the system board.	Go to step 3	Problem resolved
3	Check continuity on the cable between the rear second transfer roll arm and the 1 lead on the transfer HVPS board.	Replace the “Transfer HVPS board removal” on page 4-80.	Check the connection at the second transfer roll arm.

One color has light print over the entire page

Step	Action and questions	Yes	No
1	Print cartridge - Make sure the cartridge is seated properly and all packaging material is removed from the cartridge. Has all packaging material been removed and the cartridge seated correctly?	Go to step 2	Remove the packaging material and seat the cartridge.
2	Print cartridge - The cartridge may be out of toner. Change or switch the cartridge. Do you continue to have the same problem?	Go to step 3	Problem resolved
3	Cartridge contact assembly - Check the cartridge contact block. Make sure the PC drum contact pin is not stuck. See “Cartridge contact assembly pin locations” on page 5-4 to identify the PC drum contact pin.	Go to step 4	Replace the cartridge contact block.

Low image density

Note: If all colors have a low image density problem set the Print Darkness to High from the user's menu.

- If only one color has a problem, go to “Step A.”
- If all colors have a problem, go to “Step B.”

Step A

Step	Action and questions	Yes	No
1	Print cartridge - Make sure the print cartridge is seated correctly. Is the print cartridge seated correctly?	Go to step 2	Install the print cartridge correctly and recheck
2	The print cartridge may be out of toner. Try a new print cartridge. Does a new print cartridge fix the problem?	Problem solved	Replace the “Transfer HVPS board” on page 4-81

Step B

Step	Action and questions	Yes	No
1	Make sure that color calibration has not been disabled in the Diagnostics menus, especially if the printer has been previously serviced. Was color calibration disabled?	Set Color Calibration on	Go to step 2
2	Toner density calibration - Run toner density calibration from the Utility menu. Does this fix the problem?	Problem solved	Replace the “Transfer HVPS board” on page 4-81

Poor color alignment

Step	Action and questions	Yes	No
1	Print cartridge - Make sure that the print cartridges are properly inserted and are seated properly in their respective V blocks. Are the cartridges seated correctly?	Go to step 2	Install the cartridge(s) correctly
2	Front cover and cartridge contact block - Check the front cover and the cartridge contact block to make sure that all the springs and cartridge hold downs are present and correctly installed. Are all springs and cartridge hold downs present and correctly installed?	Go to step 3	Replace any missing or damaged springs or hold downs
3	ITU - Make sure that the ITU legs are properly seated onto the rail at the right side of the printer. This is visible by removing the yellow print cartridge. Is the ITU seated correctly?	Go to step 4	Reinstall the ITU. If the problem continues, replace the "ITU assembly" on page 4-46
4	Alignment - Enter the Diagnostics Menu. Perform the alignment for the color required. See "ALIGNMENT" on page 3-15.		

Negative ghosting or faded image

The print has a negative ghost on the page or the image is faded, particular with text. This problem may happen with any color and can be mistaken as toner smudges on the page.

Step	Action and questions	Yes	No
1	Check the bellcranks of the color that is having the problem. Is a bellcrank broken or missing?	Replace the broken or missing bellcrank.	Got to step 2
2	Check each of the springs that attach to the bellcranks to make sure they are attached and not broken or missing. Are the springs for the color having the problem missing or unattached?	Repair or replace the spring as necessary.	Look for any signs of missing or damaged parts in the area of the color having the problem, including the ITU.

Residual image

- If only one color has a residual image repeated every 95mm, replace the print cartridge.
- If all colors have a residual image 147 mm from the top of the page, replace the fuser assembly.

Note: Do the following steps *before* you replace the fuser assembly:

1. Check Media Type setting on the operator panel. If the setting is for light paper, select the correct setting for the current media type.
2. If the problem continues, set the fuser temperature selection to High.
3. If the problem continues, check the page count. If the page count is greater than 200K copies and the fuser has not been replaced, advise the customer to install a new fuser CRU or a maintenance kit.
If only one color has a residual image problem, go to **“Horizontal lines or streaks” on page 2-137**.

Uneven printing

- If all colors have uneven print, replace the ITU assembly.
- The uneven print may appear as spots or streaks that are different on each page. The most likely cause for this type of problem is damage to the ITU belt in the ITU assembly. Replace the ITU assembly. See **“ITU assembly removal” on page 4-37**.
- If only one color is missing or printing uneven, go to step 1.

Step	Action and questions	Yes	No
1	Print cartridge - Make sure the cartridge is seated properly and that all packing material has been removed from the cartridge. Has all packing material been removed? Is the cartridge seated correctly?	Problem solved	Go to step 2
2	Cartridge check - the cartridge may be out of toner or have another toner problem. Try a new toner cartridge. Does a new toner cartridge fix the problem?	Problem solved	Call your next level support

Toner smears or rubs off the page with no error code displayed

Note: This type of problem is associated with improper fusing or incorrect settings for media type being used.

Step	Action and questions	Yes	No
1	Media settings - Check to see if the printer is set for light paper. Is the printer set for light paper?	Set the printer for current media type and go to step 2	Go to step 3
2	Does resetting the media type fix the problem?	Problem solved	Go to step 3
3	Fuser settings - Set the fuser to High in the CE menu. Does setting the fuser to High fix the problem?	Problem solved	Replace the fuser assembly. See “Fuser assembly removal” on page 4-31

Smudged or distorted images on fused page

Step	Action and questions	Yes	No
1	Remove the ITU assembly and check for any signs of debris near the paper feed reference edge mechanism underneath the ITU assembly. Are there any signs of any debris in this location?	Remove the debris	Go to step 2
2	Check for any signs of debris on the surface of the ITU belt near the toner patch sensor (TPS) which is the white egg shaped device located on the front left corner of the ITU assembly. Note: When toner cartridges are replaced, small pieces of plastic may drop off of a toner cartridge and be deposited on the ITU belt. Are there any debris in this location?'	Remove the debris	Look for any signs of damage to the ITU belt. If found, replace the ITU assembly.

Toner is on the back of the printed page

Do the following steps before proceeding with this service check:

1. Enter the Diagnostics Mode.
2. Select **Print Test, Tray 1, Continuous** from the menu.
3. Run at least 20 pages of text and see if the problem remains.
 - If toner is still on the back of the printed page, proceed with this service check.
 - If the problem is on the top two inches of the page replace the second transfer roll.
 - If the toner is “stringy” over the top half of the page, go to step 1.

Step	Action and questions	Yes	No
1	Media settings - Check to see if the printer is set for light paper. Is the printer set for light paper?	Set the printer for current media type and go to step 2	Go to step 3
2	Does resetting the media type fix the problem?	Problem solved	Go to step 3
3	Fuser settings - Set the fuser to High in the CE menu. Does setting the fuser to High fix the problem?	Problem solved	Replace the fuser assembly. See “Fuser assembly removal” on page 4-31

Transparency print quality is poor

Step	Action and questions	Yes	No
1	Transparencies - Check the media type and transparency in use. Are the recommended transparencies and media type used?	Go to step 2	Inform the customer
2	Is the quality of the transparency poor or do brown colors appear when projected?	Go to step 3	Go to step 4
3	Fuser settings - From the Diagnostics Menu select fuser settings and set to high. Does this fuser setting fix the problem?	Problem solved	Replace the fuser assembly. See "Fuser assembly removal" on page 4-31
4	Does the transparency have a splotchy appearance?	Go to step 5	Replace the second transfer roll. See "Second transfer roll removal" on page 4-79
5	Transfer setting: High - From the Diagnostics Menu set Transfer setting to High. Does this transfer setting fix the problem?	Problem solved	Go to step 6
6	Transfer setting: Low - From the Diagnostics Menu set Transfer setting to Low. Does this transfer setting fix the problem?	Problem solved	Replace the second transfer roll. See "Second transfer roll removal" on page 4-79

Second transfer roll service check

Note: The second transfer roll is 51.03 mm (2.009 inches) in circumference. Any print quality problems such as lines that are spaced apart indicate you should check the second transfer roll for damage, toner, or foreign material.

Note: The second transfer roll is also part of the maintenance kit and should be replaced when a “83 ITU Maintenance” message appears. Ask the customer if they have replaced the second transfer roll recently.

Note: If any of the following problems occur, go to **“Print quality service checks” on page 2-136:**

- A problem with only one color
- Light or very light print

CAUTION: Make sure the printer is powered off before making any checks on the second transfer roll or associated parts for personal safety and to prevent damage to the printer.

Step	Actions and questions	Yes	No
1	Second transfer roll assembly—check the second transfer roll for any signs of toner buildup, surface damage to the roll, oil, or other contaminants on the surface of the roll. Do you see any problems with the second transfer roll?	Replace the second transfer roll. See “Second transfer roll removal” on page 4-79	Go to step 2
2	Transfer arms, springs, and associated hardware—call your next level of support. None of these parts are service related parts. Is there any problem with the associated hardware?	Call your next level support	Go to step 3
3	Transfer high voltage power supply, HV wiring and contacts—check the second transfer cable (transfer HVPS contact I to the second transfer roll rear arm contact) for correct installation. Is the cable installed correctly?	Go to step 4	Install the cable correctly
4	Check the continuity of the second transfer cable. Is there continuity?	Replace the FRUs in order: 1. Second transfer roll. See “Second transfer roll removal” on page 4-79 2. Transfer HVPS board. See “Transfer HVPS board removal” on page 4-80 . If this does not correct the problem, go to step 5.	Replace the second transfer cable
5	Make sure the ITU Bias Spring is not broken or missing for the color(s) that is having Transfer problems. Is the ITU Bias Spring broken, off, or missing?	Repair as necessary	Go to step 6
6	Check the transfer HVPS to ITU HV transfer terminal for the color(s) that is having transfer problems. Is the cable disconnected or broken?	Reinstall or replace the cable	Go to step 7

Step	Actions and questions	Yes	No
7	<p>Transfer terminal contact assembly and ITU transfer bellcrank—check the transfer terminal contact, transfer cable, and ITU transfer bellcrank assemblies to make sure they are installed correctly, not loose, or broken.</p> <p>Are there any problems with the transfer terminal contact, transfer cable connection, or ITU transfer bellcrank assemblies?</p>	<p>Repair or replace as necessary. If this does not correct the problem, contact your next level support.</p>	<p>Replace the FRUs in order:</p> <ol style="list-style-type: none"> 1. Transfer HVPS board. See “Transfer HVPS board removal” on page 4-80 2. Engine board. See “Engine board removal” on page 4-29 3. ITU assembly. See “ITU assembly removal” on page 4-37

Tray 1 service check

Tray 1 does not stay seated or fit correctly in the printer, the media fails to feed correctly from Tray 1 or Tray 1 is difficult to install

The Tray 1 Feed Test in the Diagnostics Menu can be used to help isolate problems with paper feeding from Tray 1.

Step	Action and questions	Yes	No
1	<p>Check the following parts in tray 1 for broken or missing parts.</p> <ul style="list-style-type: none"> • Tray bias spring loose or missing • Tray bias bellcrank <p>Are any parts broken, loose, or missing?</p>	<p>Repair or replace parts as necessary</p>	<p>Go to step 2</p>
2	<p>Make sure the autocompensator has fully retracted to its upper position.</p> <p>Does the autocompensator retract correctly?</p>	<p>Go to step 3</p>	<p>Go to “Autocompensator service check” on page 2-114</p>
3	<p>Check for any signs of damage to the paper tray guide.</p> <p>Is the paper tray guide damaged, loose or missing?</p>	<p>Replace the Paper Tray Guide.</p>	<p>Go to “Autocompensator service check” on page 2-114</p>
4	<p>Check the following parts for wear, damage, or missing parts.</p> <ul style="list-style-type: none"> • Wear strips • Restraint pads • Wear clip • Side restraint • Back restraint and back restraint latch <p>Are there broken, worn or missing parts?</p>	<p>Repair or replace parts as necessary</p>	<p>Go to “Autocompensator service check” on page 2-114</p>

Tray 1 paper size sensing service check

The printer does not sense the size of the media installed in tray 1.

Note: If there is a problem when installing tray 1, tray 1 is difficult to remove or does not stay locked in position, go to **“Tray 1 service check” on page 2-149.**

Step	Action and questions	Yes	No
1	Make sure tray 1 is installed and seated correctly in the printer. Is the tray correctly installed?	Go to step 2	Install Tray 1 correctly. If there is still a problem, go to “Tray 1 service check” on page 2-149.
2	Is another 500-sheet tray available?	Go to step 3	Go to step 4
3	Try another 500-sheet tray in place of the internal tray 1 paper tray. Does this fix the problem?	Go to step 4	Go to step 7
4	Check tray 1 for broken parts, especially the teeth on the back restraint. Is the back restraint broken or any of the teeth broken or missing?	Replace the Back Restraint	Go to step 5
5	Check the following parts to make sure they are installed correctly and they are not damaged or broken. <ul style="list-style-type: none"> • Size sensing gear cover • Size sensing gear • Size sensing barrel cam Note: Make sure the size sensing barrel cam is correctly installed. Observe the position of the cam tab through the size sensing gear cover. Observe the cam position through the cover by moving the back restraint and observe the cam detent. In the A5 media position the detent should be visible through the opening in the gear cover. Are all the parts installed correctly, and not broken or missing?	Go to step 6	Replace tray 1.
6	Make sure the following parts in the printer are operating correctly. Check for any signs of broken or missing parts. <ul style="list-style-type: none"> • Size sensing springs • Size sensing links • Size sensing bracket Are there broken or missing parts?	Repair or replace parts as necessary	Go to step 7
7	Check paper size sensing assembly to make sure that the size sensing links correctly actuate the paper size switches on the engine board. Does tray 1 correctly actuate the paper size switches on the engine board?	Replace the engine board. See “Engine board removal” on page 4-29	Repair or replace parts as necessary

3. Diagnostic aids

This chapter explains the tests and procedures to identify printer failures and verify repairs have corrected the problem.

There are different test menus that can be accessed to identify problems with the printer.

Diagnostic aids

Printhead diagnostics

If you get a printhead error, follow this diagnostic to find the specific failure. See **“Printhead diagnostics”** on **page A-1** for a color version of this procedure.

1. Verify that all the printhead cables are properly seated.
If the printhead cables are properly seated and the error remains, record the error code. Continue to the next step.
2. Determine how to setup the printhead diagnostic tool.
 - a. If the printhead diagnostic tool is not configured as in the illustration below, reconfigure it to match.

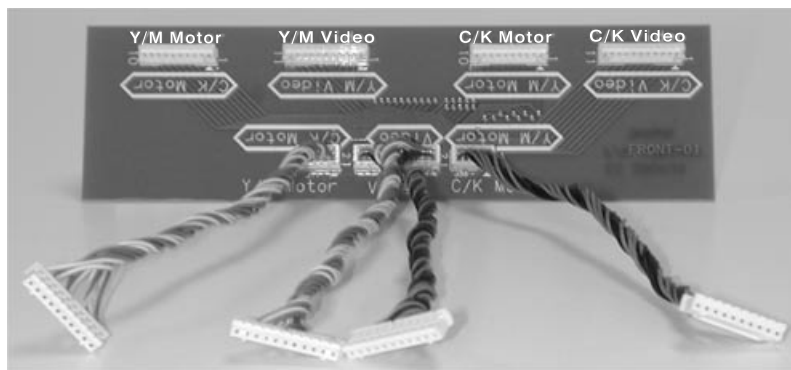

- b. Select which pair of printheads to switch based on the error code.
If the printer displays the codes that indicate yellow or cyan, use the tool to switch the yellow and cyan signals. If the error code indicates a magenta or black error, use the tool to switch the magenta and black signals.

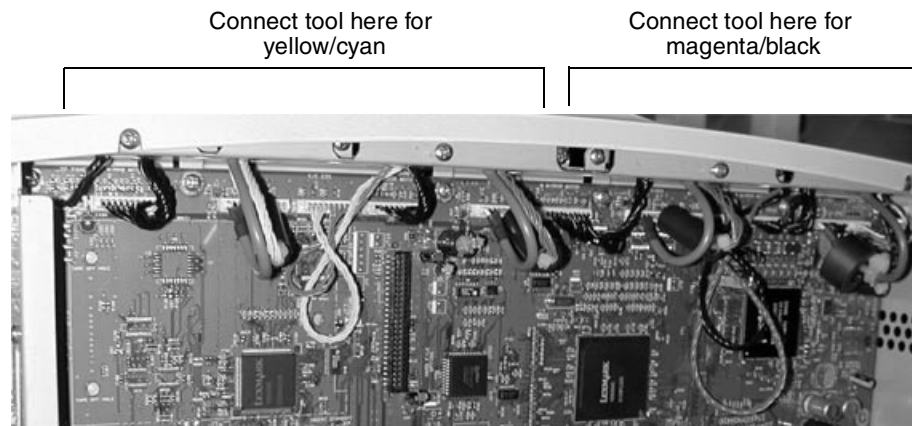

3. Install the printhead diagnostic tool and determine the problem.
The following procedure shows the yellow and cyan switch as an example.
 - a. Turn off the printer.
 - b. Unplug the printhead cables from the RIP board in the printer and connect them to the printhead diagnostic tool.

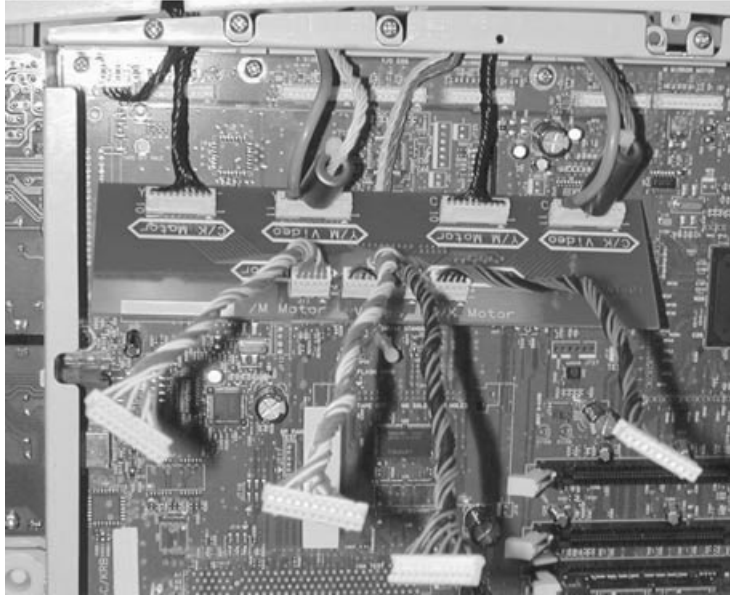

- c. Connect the printhead diagnostic tool cables to the connectors on the RIP board in the printer. This reverses the printhead color signals for the selected pair of colors.



- d. Turn on the printer and note the new error codes.
- If an automatic calibration begins, **36 Printer Service Required** may appear. The printhead and RIP board are working correctly and the printhead cable connections should be checked. Press **Go** to clear the error.
 - If the error code remains the same, replace the RIP board. If that solves the problem, you are finished.
 - If the printer displays a different printhead error code, which indicates another color, the printhead or the printhead cables are defective. See the table below for printhead codes.
- For example, the printer originally displays the printhead error code **108** (yellow). After switching the signals using the diagnostic tool, the printer displays the printhead error code **106** (cyan).

	Printhead error codes		Printhead error codes	
	Yellow	Cyan	Magenta	Black (K)
For 10x errors	108	106	107	109
For 11x errors	117	115	116	114
For errors 169–175	175	171	173	169
Not commonly seen	176	172	174	170

4. Remove the printhead diagnostic tool.
5. The problem is in either the printhead cables or the printhead. Replace the printhead cables. If the problem remains, replace the printhead.
6. Perform the printhead adjustments.

Print quality defect locator chart

The print quality locator chart is copied below, but the tool is a transparent sheet available with this printed book. Use the tables and rulers to determine the source of repeating defects.

Using the chart

Measure repeating horizontal lines from the reference lines at the top to determine what may have caused the lines to form in that pattern. Be sure to use portrait orientation for the test file.

Rollers

Component description	Component	Planes affected	Defect period	
			mm	inches
Charge roll	Cartridge	One	38.7	1.5
PC drum		One	96.8	3.8
PC cleaner		One	96.8	3.8
Developer roll		One	47.9	1.9
TAR		One	46.4	1.8
Toner meter		One	1092.2	43
Cart auger		One	349.9	13.8
First transfer roll	ITU	One	53.2	2.09
Second transfer roll	Second transfer roll	All	59.4	2.34
ITU drive/backup rolls	ITU	All	101.0	3.98
ITU reverse roll	ITU	All	50.5	1.99
Fuser hot roll	Fuser	All	147.0	5.79
Fuser BUR		All	147.0	5.79

Rollers

Component description	Component	Planes affected	Defect period	
			mm	inches
Metering rolls	Reference Edge	All	47.0	1.85
Color charge roll short	C, M, or Y cart	C, M and Y	101.0	3.98

NIP shock

NIP distances	Defect period	
	mm	Inches
Y-C-M-K cartridge spacing	101.0	3.98
K to second transfer roll	144.6	5.69
M to second transfer roll	245.6	9.67
C to second transfer roll	346.6	13.65
Y to second transfer roll	447.6	17.62
Meter 1 to second transfer	164.8	6.49
Meter 2 to second transfer	126.4	4.98
Meter 3 to second transfer	86.4	3.40
Meter 4 to second transfer	51.4	2.02
Second transfer to fuser	319.4	12.57
Fuser nip to first redrive	50.0	1.97
Fuser nip to exit sensor	58.2	2.29
Fuser nip to exit tray nip	420.3	16.55

Printing the chart

The printer has an internal copy of the defect locator chart under the Help Menu. Verify the proper image size by measuring any of the marks on the chart and comparing them to the corresponding measurement in the chart. Use Step 2 if adjustments are needed.

Copying the chart

Use the provided transparent sheet if at all possible. If you need to make a copy, be aware that fax machines, digital scanners, and xerographic copiers can distort images. Charts should be printed using the transparent copy provided in the service manual. In order to maintain the accuracy of the edge rulers, the following steps should be heeded when printing a copy of the Defect Location Chart.

1. When printing this document, make sure "Fit to page" is not selected.
2. Measure the distance between the **Reference** line and the 110 mm **Calibration Mark** to verify that it is correct. If the distance is inaccurate, the bottom registration margin setting can be adjusted to correct the discrepancy. Increasing the bottom margin value stretches the image, reducing it shrinks the image. Original margin settings should be noted in the case that these changes adversely effect the print quality or registration when printing normal documents.

Print quality

For a transparency of the defect locator chart, go to the back of the hard copy service manual.

Note: If you want to copy the chart, then the following should be observed.

Since fax machines, digital scanners, and xerographic copiers can distort images, charts should be printed using the transparent copy provided in the service manual. In order to maintain the accuracy of the edge rulers, the following steps should be heeded when printing a copy of the Defect Location Chart.

1. When printing this document, make sure "Fit the page" is NOT selected.
2. Measure the distance between the reference line and the 110 mm calibration mark to verify that it is correct. If the distance is inaccurate, the bottom registration margin setting can be adjusted to correct the discrepancy. Increasing the bottom margin value stretches the image, reducing the bottom margin value shrinks the image. Original margin settings should be noted in case these changes adversely effect the print quality or registration when printing normal documents.

Partial Print Test

This procedure is also available in color. See "**Partial Print Test**" on page A-16.

Diagnostic procedure for missing or faded planes

1. Turn the printer off.
2. Remove all cartridges and the ITU.
3. Inspect the bellcranks.
4. Enter the Configuration Menu. See "**Entering CONFIG MENU**" on page 3-7.
5. Select **Prt Quality Pgs** and press **Select**.
6. Open the vacuum transport belt (VTB) jam access door and watch the test pages pass from left to right over the VTB.
There is a delay between the first and second page.
7. Once the pages are printed, examine the pages for to confirm the color plane is not printing.
Note: The third page is particularly important since it is the image on the belt when the test printed.
8. Select **Prt Quality Pgs** and press **Select**.
Open the VTB through the access door and, once again, watch the test pages pass over the VTB.
9. When the top half of the second page passes over the VTB, quickly open the front cover. The printing stops.

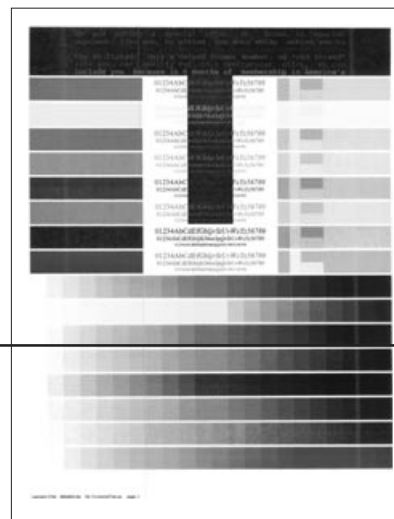
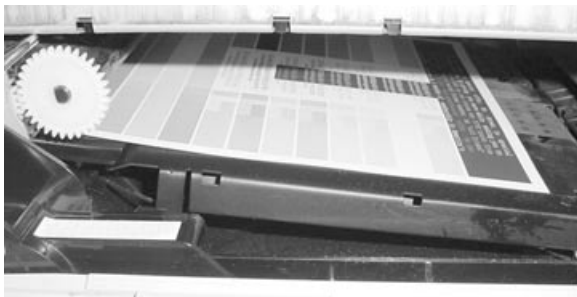

Approximate
final stopping
place

10. Remove all four toner cartridges and set them face down.
Look at the surface of each toner cartridge and check for a developed image.



Interpreting the results

If the developed images are not visible on one of the PC drums, the following components should be checked:

- Toner cartridge - Switch cartridges to determine if the problem stays with the slot or cartridge.
- Cartridge contact block pins - Verify that pins are spring loaded and properly positioned. See **“Cartridge contact assembly removal” on page 4-23**
- Developer HVPS cable - Make sure that there is no damage to the cable running from the system board.
- Developer HVPS board.
- System board.

If the image is well developed on the PC drum, but the same plane is missing or faded on the ITU belt, the following components should be checked:

- Bell cranks - Check the condition of the bell cranks.
- Continuity on the bell crank circuit - Turn the printer off. Using a multimeter, check the continuity between the rear bell crank contact for the failing color and the respective cable on the transfer HVPS board. See **“Transfer high voltage power supply (HVPS)” on page 5-19.**
- Transfer HVPS cable - Make sure that there is no damage to the cable running from the system board to the transfer HVPS board. Verify the connection at both ends.
- Transfer HVPS board.
- Engine board.

Configuration Menu

The Configuration Menu (CONFIG MENU) contains a set of menus, settings and operations which are infrequently used by a user. Generally, the options made available in this menu are used to configure a printer for operation.

The following are available from the Configuration Menu:

- Black&White Lock
- Fuser Cnt Value
- Reset Fuser Cnt
- Prt Quality Pgs (This is not displayed if in Demo mode.)
- Color Trapping
- SIZE SENSING
- TYPE SENSING
- SENSED TRANS
- SENSED PAPER
- CALIBRATE TRAYS
- Panel Menus
- PPDS Emulation - This only displays if the PPDS interpreter is available.
- Download Emuls - This only displays if at least one Downloaded Emulator is installed.
- Demo Mode
- Factory Defaults
- Energy Conserve
- ITU Alignment
- Auto Color Adj
- Error Log
- Exit Config Menu (Press **Select** to exit CONFIG MENU and reboot.)

Note: An asterisk(*) in the value list in the following menus indicates the default value.

Entering CONFIG MENU

To access to the CONFIG MENU:

1. Turn the printer off.
2. Press and hold **Select** and **Return** while you turn the printer on.
3. When `Performing Self Test` displays, release the buttons.

Black&White Lock

Select **Black&White Lock** from the CONFIG MENU.

Values: =On
 =Off

Fuser Cnt Value

Select **Fuser Cnt Value** from the CONFIG MENU. You can not reset this value. It only displays if the Maintenance Warning and Intervention function is enabled in the printer Configuration ID.

The value can be viewed by pressing **Select**.

Reset Fuser Cnt

This only displays if the Maintenance Warning and Intervention function is enabled in the printer Configuration ID. The fuser maintenance page counter is incremented when a page is printed and incremented by two when a duplex sheet is printed. The counter can be used to track printer usage. When the counter reaches 150,000, the printer posts a fuser maintenance message on the operator panel.

1. Select **Reset Fuser Cnt** from the CONFIG MENU to view the page count.
2. Press **Return** to return to the previous menu or press **Select** to reset the maintenance page counter back to zero.

Prt Quality Pgs

The Print Quality Test consists of five pages. Pages one and two contain a mixture of graphics and text. The remainder of the pages only contain graphics. Use this test to identify print quality problems. The Test Pages must be printed on A4, Legal or Letter paper.

1. Select **Prt Quality Pgs** from the CONFIG MENU.
2. . Press **Select** to print the pages.

Go to **“Print Quality Pages—Title page (total of five)” on appendix page B-3** for representative samples of the pages.

Color Trapping

Color trapping is an aid to graphics and text. When a text or graphics appear over other colors, a misalignment may allow white paper to show through at the borders of the colors. Color trapping reduces the cutout area under the upper image so a slight misalignment does not show. This only affects PostScript emulation printing.

Select **Color Trapping** from the CONFIG MENU. The values are:

- =Off
- =1..... 5(2*)

SIZE SENSING

Only paper sources that support Size Sensing are displayed.

1. Select **Size Sensing** from the CONFIG MENU.
2. Select a tray. Only those trays with size sensing display. These can include:
 - Tray 1 Sensing
 - Tray 2 Sensing
 - Tray 3 Sensing
 - Tray 4 Sensing
3. Select **Auto** to turn size sensing on for that tray, or select **Off** to disable size sensing.
4. Select **Return** to exit.

TYPE SENSING

Only paper sources that support Auto Type Sensing are displayed.

1. Select **TYPE SENSING** from the CONFIG MENU.
2. Select a tray. Only those trays with type sensing display. These can include:
 - Tray 1
 - Tray 2
 - Tray 3
 - Tray 4
3. Select **Auto** to turn type sensing on for that tray, or select **Off** to disable type sensing.
4. Select **Return** to exit.

SENSED TRANS

1. Select **SENSED TRANS** from the CONFIG MENU.
2. Select the tray. Only those trays with

SENSED PAPER

Only paper sources that support auto type sensing are displayed. The factory default paper type or each tray is determined by the value of Configuration ID.

For example, the default values may be as follows:

- Tray 1 factory default paper type = Plain Paper
- Tray 2 factory default paper type = Plain Paper or Custom Type 2
- Tray 3 factory default paper type = Plain Paper or Custom Type 3
- Tray 4 factory default paper type = Plain Paper or Custom Type 4

The following media can be sensed by Tray 1, Tray 2, Tray 3, and Tray 4:

Plain Paper, Glossy Paper, Card Stock, Labels, Bond, Letterhead, Preprinted, Colored paper, Custom Type 1, Custom Type 2, Custom Type 3, Custom Type 4, or Custom Type 6

CALIBRATE TRAYS

Only trays that support transparency sensing are displayed.

The following are displayed whenever a tray has been detected that is not calibrated.

Tray x Not Calibrated

This message usually indicates a user-correctable NVRAM problem. The tray may not have been calibrated or the NVRAM variable for tray calibration may be missing.

To calibrate the tray:

1. Select **CALIBRATE TRAYS** from the CONFIG MENU.
2. Select the tray you want from the menu.
You are prompted to load paper into the selected tray (not transparencies).

Load <input source> Plain Paper

3. Press **Go** to initiate calibration.
4. Press **Return** to stop the calibration and return to the previous menu.

Panel Menus

Disabling Panel Menus prohibits users from modifying any setting or executing any operation available in the Ready Menu group.

Select **Panel Menus** from the CONFIG MENU

=Enable*
=Disable

PPDS Emulation

This only displays if the PPDS interpreter is available.

Select **PPDS Emulation** from the CONFIG MENU.

=Activate
=Deactivate*

Download Emuls

This only displays if at least one downloaded emulator is installed.

Select **Download Emuls** from the CONFIG MENU.

=Disable

Demo Mode

This printer supports a demo mode that is usually used in retail environments to illustrate the features of the printer. The printer features are illustrated by demonstration files stored in the RIP firmware, flash option, or disk option.

Select **Demo Mode** from the CONFIG MENU.

=Deactivate*
=Activate

Factory Defaults

The customer can restore either the network settings or the base printer settings to their factory default values. When Restore Base is selected, non-critical base printer NVRAM settings are restored. When Restore Network is selected, all network NVRAM settings are restored to their factory default settings. This option is only available on models with an integrated network adapter. In either case, Restoring Factory Defaults is displayed after the operation is selected.

Select **Factory Defaults** from the CONFIG MENU.

- =Restore Base
- =Restore Network

Note: **Restore Network** is only listed on models that have integrated network support.

Energy Conserve

When Energy Conserve is on, the customer does not have access to disable the Power Saver function. When Energy Conserve is off, Disable appears as an additional menu item in the Power Saver menu. This setting only affects the values that are displayed in the Power Saver Menu.

Select **Energy Conserve** from the CONFIG MENU.

- =On*
- =Off

ITU Alignment

This alignment is required anytime you replace the ITU Assembly.

1. Select **ITU Alignment** from the CONFIG MENU.
A test page is printed.
2. After the test page prints, enter alignment values for each alignment setting.
Example:

A Alignment 0*

On printed sheet:

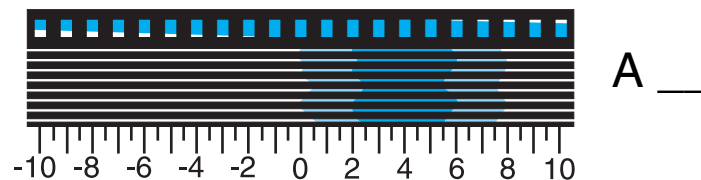

Enter:

A Alignment 4

The alignment values range from -10 to + 10 in 0.5 increments (0*).

3. Press **Select** to continue to the next alignment value.
4. You will be prompted to continue through Test L, pressing Select to save each value.
5. When the tests are done, press **Go** or **Return** to exit.

Auto Color Adjust

Automatic color adjustments periodically occur during printing, based on internal algorithms. The following situations prompt the adjustment:

- If the printer detects a new or different color cartridge is installed, usually at power on or when the cover is closed.
- If the printer detects a new or different ITU is installed, usually at power on or when the cover is closed.
- If the fuser detects at power on that the fuser temperature is at 60° C.
- If Power Saver has been active for eight hours or more.
- If the printer was turned off during a calibration cycle.
- At the Ready state, if one of several internal engine parameters has exceeded a given threshold.
- If requested by the user from the operator panel or by a PjL command.
- At the Ready state if more than 500 pages are printed since the last calibration. This value can be adjusted in this menu.

Selecting **Off** disables all Auto Color Adjust prompts listed above except the request of the user or the PjL command.

Select **Auto Color Adjust** from the CONFIG MENU.

=Off
=100.....1000 (500*)

The values are in increments of 50. The default is 500.

Exit Config Menu

Select **Exit Config Menu** and press **Select** to exit the CONFIG MENU and reboot the printer.

Diagnosics Mode

To run the printer diagnostic tests described in this chapter, put the printer in Diagnostics Mode.

The tests display on the operator panel in the order shown:

- REGISTRATION
- ALIGNMENT
- TOP FINE MAR ADJ
- MISC TESTS
- PRINT TESTS
- HARDWARE TESTS
- DUPLEX TESTS (if duplex is installed)
- INPUT TRAY TESTS
- OUTPUT BIN TESTS
- FINISHER TESTS (if finisher is installed)
- BASE SENSOR TEST
- DEVICE TESTS (if optional flash or disk installed)
- PRINTER SETUP
- EP SETUP
- ERROR LOG
- Exit Diagnostics

Entering Diagnostics Mode

To enter the Diagnostics Mode:

1. Turn the printer off.
2. Press and hold the **Go** and **Return** buttons.
3. Turn the printer on.
4. Release the buttons when *Performing Self Test* is displayed.

Exiting Diagnostics Mode

Select **Exit Diagnostics** to exit the Diagnostics Mode and return to normal mode.

REGISTRATION

The print registration range is:

Bottom Margin: -25 to +25
 Top Margin: -25 to +25
 Left Margin: -12 to +12
 Right Margin: -12 to +12

To set print registration:

1. Select **REGISTRATION** from the Diagnostics Mode.

T=sxx*	B=sxx*
L=sxx*	R=sxx*

B=Bottom margin
 T=Top margin
 L=Left margin
 R=Right margin
 s=Negative values, space blank for positive values
 xx=Margin value
 *=Default value

2. Enter the values.

The Top margin sign/value pair blinks. This indicates it is the margin value being changed.

- To select the margin value to change, press **Select** until the margin value pair you want to change is blinking.
- To change the margin value press **Menu**.

Print adjustment tip: Adjusting the Top and Right margins moves the entire image. Adjusting the Bottom and Left margins causes the image to expand or compress. It is easier to adjust the Top and Right margins, first, then adjust the Bottom and Left.

A *positive* increase in value makes the following changes to the margin locations:

Top margin: Moves down the page
 Left margin: Moves to the left
 Right margin: Moves to the left
 Bottom margin: Moves down the page

3. When the value you want is displayed, press **Select** to save the value. To exit the Registration menu, press **Return**.

To verify the margin values are correct you must print the Quick Test Page from the registration screen. Press **Go** to print the test page. While printing, *Quick Test Printing* is displayed. Once printing is complete, the Registration screen appears. See **“Quick Test” on appendix page B-8** for an example of the page.

The Quick Test Page should be printed on letter or A4 paper.

4. To exit the Registration menu, press **Return**.

ALIGNMENT

Cyan, Yellow, Magenta

Setting printer alignment

1. Select **ALIGNMENT** from the Diagnostics Mode.
2. Select one of the following: **Cyan, Yellow, or Magenta**.

The following screen is displayed:

T=sxx*	R=sxx*
L=sxx*	Z=sxx*

Value:	Description:	Range:
T=	Top Margin Offset	-128 to +127
L=	Left Margin Offset	-300 to +300
R=	Right Margin Offset	-300 to +300
Z=	Theta Offset (Skew compensation)	-16 to +16
s	=sign for negative values (this space is blank for positive values)	
xx	=margin value.	
*	=Default Value	

3. Run an Alignment Test Page before changing any of the settings.
4. When the alignment screen is displayed, the Top Margin sign/value pair flashes. To change the value, press **Menu**. Once the value is displayed, press **Select** to save the value and move to the next value. The margin values blink in the following order: Top, Left, Right and Theta. To skip a margin value, because its value is correct, press **Select**. The default value remains the same.
5. If **Return** is selected and you exit the alignment menu after a margin value has been changed but not saved, then the default value is not changed. However, if the Alignment Test page is requested after a margin value has been changed but not saved, then the default value is changed and the Alignment Test Page is printed using the new value.
6. To verify that the margin values are correct, you must print the Alignment Test Pages. Press **Go** from the Alignment Test screen that displays each of the margin values. Pressing **Go** serves as a hot key to the Alignment Test Pages. Buttons are not active when the Alignment Test Pages are printing.

Note: The Alignment Test Pages consist of all three color alignment pages. The Alignment Test Page should be printed on A4 or Letter paper.

The printer tries to print the test page from the default paper source, however if the default source only supports envelopes, then the page prints from Tray 1.
7. Complete a Line Length Calibration from the PRINT TESTS in the Diagnostics Menu.
8. To exit the Alignment Test press **Return**.

Drift Sensors

This check is used to display the status of the thermal system used to compensate for printhead drift.

The following screen is displayed when the test is selected:

Com=aaaa	M=bb
C=cc	Y=dd K=ee

Values:

If:	Value:	Description:
Com=	Err	RIP to A/D communication error
	Good	Communication is good
M=, C=, Y=, or K=	OP	Open thermistor error
	SH	Short thermistor error
	RA	Range error
	Number	Detected temperature in Celsius of last reading. Indicates the system is functioning properly.

If Com=Err, replace the system board. See **“System board” on page 4-80**.

If a number displays, or C, Y, or K=OP, or SH, check the following:

1. Check the cable of the appropriate thermistor (cyan, magenta, yellow, or black) to make sure it is installed correctly to the system board and to the thermistor board. If correct, go to step 2.
2. Check the continuity of the appropriate cable. Replace the cable if there is no continuity. If continuity is correct, go to step 3.
3. Replace the appropriate thermistor assembly. If this does not fix the problem, replace the system board.

To exit the test, press **Return** or **Stop**.

TOP FINE MAR ADJ

Do not change this setting without consulting your next level of support.

MISC TESTS

Motor Detect

This test initiates an Automated Motor Detection. It must be performed if the NVRAM contents are erased such as when a RIP or engine board has been replaced. This test must be performed anytime the ITU motor, Fuser motor, or Cartridge drive motors are replaced.

To run the Miscellaneous Tests:

1. Select **Misc Tests** from the Diagnostics Mode.
2. Select **Motor Detect**.
3. Remove all the print cartridges from the printer.
4. Press **Go**.

Motor Detection in progress is displayed:

The test lasts approximately ten seconds. No buttons are active during detection and the test completes automatically.

Belt Tracking (ITU 4th point adjustment)

This test is used to determine the need for the ITU Shim to correct 4th point alignment following the ITU replacement.

Note: Remove all cartridges before initiating this test and note the belt position.

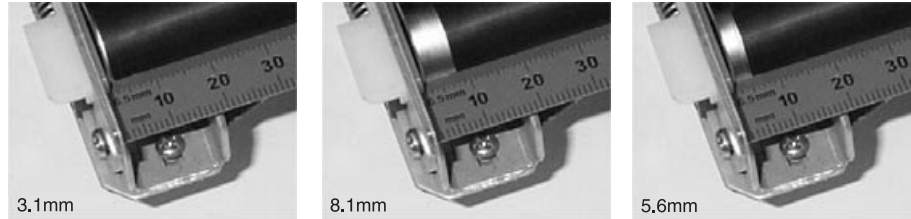

1. Select **Belt Tracking** from the menu.
The following screen is displayed:

Test in Progress

The operation normally takes approximately 15 minutes to complete. It may take less time if the test fails. When the test is complete, the following screen is displayed:

Test Complete
 Code <pass code>

or

Test Failed
 Code <fail code>

If the test is successful, the pass code will be a number between - 250 and + 250. Do not install a shim. If the test fails, then a fail code will be a number between 0 and 200 and a message indicates the cause of the failure. The following is a list of failure codes:

- Cover open.
- Cartridges NOT removed.
- Less than three revolutions before the test ended (may never be displayed). Belt tracked to front.
- 100 revolutions when test ended, belt tracked to front.
- 103 <=3 revs before test ended. Probably never displayed. Belt tracked to rear.
- 104-200: numbers of revs when test ended +100. Belt tracked to rear.

2. To exit the test, press any button.
3. Verify the failure code by comparing the belt position to the initial position. Install the shim to the rear if the belt tracked to the rear. Install the shim to the front if the belt tracked to the front. Refer to the instructions included with the shim for installation.
4. After installing the shim, run the test, again. If the test fails, rerun several times as the belt needs time to stabilize. Once the test is successful, reinstall the cartridges and restart the printer.

PRINT TESTS

The Print Tests consist of the following tests:

- Tray 1
- Tray 2 (if installed)
- Tray 3 (if installed)
- Tray 4 (if installed)
- Tray 5 (if installed)
- MP Feeder
- Env Feeder (if installed)

The following test pages are available

- Print Quality Pages
- Print Line Len Pages

Print Tests (input source)

This test determines if the printer can print on media from any of the paper input sources. Each of the installed sources is available within the PRINT TESTS menu.

The content of the test page varies depending on the media installed in the selected input source.

- If a source is selected that contains paper, then a page similar to the Quick Test Page is printed and does not contain the Print Registration diamonds.
- If a source is selected which contains envelopes, then an Envelope Print Test pattern is printed. This pattern only contains text, which consists of continuous prints of each character in the selected symbol set.
- If **Continuous** is selected, all sources printing with paper sizes prints the same page continuously until the test is stopped. If continuous is selected from a source which contains envelopes then the envelope print test pattern is printed on the first envelope and the rest are blank.
- The Print Test page always prints single sided, regardless of the Duplex setting or the presence of the Duplex option.

To run the Print Test:

1. Select **PRINT TESTS** from the Diagnostics Mode.
2. Select the paper source from the menu. Only available sources display.
3. Select either **Single** or **Continuous** from the menu.

Note: If Single is selected, no buttons are active while the Print Test Page is printing. If Continuous is selected, **Return** or **Stop** can be pressed to cancel the test.

The following screen is displayed while printing.

<i><input source></i> Printing <i><media width></i>
--

<input source> Tray 1, Tray 2, Tray 3, Tray 4, Tray 5, MP Feeder, or Env Feeder
<media width> N or Narrow Width Media, or W for Wide Width Media

4. Press **Return** or **Stop** at the end of the test to return to the original screen.

Prt Quality Pgs

The print quality test has five pages of settings, various color blocks, color array scales, and color gradients.

This test may be printed from either CONFIG MENU or the Diagnostics Menu.

- When printed from the Configuration Menu, the toner cartridge lockout function is enabled, which means these pages cannot be printed unless a cartridge is installed with a Machine Class ID which matches the Machine Class ID stored in the printer NVRAM.
- When printed from the Diagnostics Test Menu, the toner cartridge lockout function is disabled.

To run the Print Quality Test page from the Diagnostics Menu, select **Prt Quality Pgs** from the menu. Once the test is started it cannot be canceled. When the test pages print the printer returns to the original screen.

Prt Line Len Pg

This test prints a color test page that is used to measure the temperature of the printheads and the reading from the PSD at calibration time.

To run the Print Line Length Page, select **Prt Line Len Pg** from the menu. No buttons are active while the Print Line Length Page is printing. Press **Return** to exit. See **“Print line length calibration” on page 4-61** for a sample of the page or page **“Print Line Len page” on page B-12**.

HARDWARE TESTS

The following Hardware Tests can be selected from this menu:

- LCD Test
- Button Test
- DRAM Test
- ROM Test
- Parallel Wrap (if available)
- Serial Wrap (if available)
- Serial 1 Wrap (if available)
- Serial 2 Wrap (if available)
- Serial 3 Wrap (if available)

LCD Test

This test verifies the operator panel LCD function.

To run the LCD Test:

1. Select **LCD Test** from the Diagnostics Menu.
The LCD test continually executes the LCD display test.
2. Press **Return** or **Stop** to cancel the test.

Button Test

This test verifies the operator panel LCD function.

To run the Button Test:

1. Select **Button Test** from the Diagnostics Menu.
With no buttons pressed, several OP (Open) messages are displayed.
2. Press each button one at a time and a CL (Closed) is display in place of OP. The proper operation of each button can be checked.
3. Press **Return** or **Stop** to cancel the test.

DRAM Test

This test checks the validity of DRAM, both standard and optional. The test writes patterns of data to DRAM to verify that each bit in memory can be set and read correctly.

To run the DRAM Test:

1. Select **DRAM Test** from the menu.
The power indicator blinks indicating the test is in progress.
2. Press **Return** or **Stop** to exit the test.

DRAM Test	128M
P:#####	F:#####

P:##### represents the number of times the memory test has passed and finished successfully. Initially 000000 displays with the maximum pass count being 999,999.

F:##### represents the of time the memory test has failed and finished with errors. Initially 00000 displays with the maximum fail count being 99,999.

Once the maximum pass count or fail count is reached, the test is stopped, the power indicator turns on solid, and the final results appear. If the test fails, **DRAM Error** appears for approximately three seconds and the failure count increases by 1.

CACHE Test

The CACHE Test is used to verify the processor cache is functioning properly.

1. Select **CACHE Test** from the menu.
The machine initiates a POR of the printer and the following screen is displayed:

Resetting the Printer

Upon completion of the POR the following screen is displayed:

Cache Test x100	
P:#####	F:#####

P:##### represents the number of times the cache test has passed, finished successfully.

Initially 000000 is displayed. The maximum pass count is 999,999.

F:##### represents the number of times the cache test has failed, finished with errors.

Initially 000000 is displayed. The maximum fall count is 999,999.

2. To exit the test, turn the printer off.

ROM Test

The ROM Test is used to check the validity of the controller board code and fonts.

To run the ROM Test:

1. Select **ROM Test** from the menu. P and F represent the same numbers for DRAM.
The power indicator blinks indicating the test is in progress. The test runs continuously.
2. Press **Return** or **Stop** to exit the test.

Each time the test finishes, the screen updates with the result. If the test passes, the Pass Count increases by 1, however if the test fails, one of the following messages appears for approximately three seconds:

```
ROM Checksum Error
ROM Burst Read Error
```

Once the maximum pass count or fail count is reached, the test stops with the power indicator on solid. The final results are displayed.

Parallel Wrap Test

Use this test with a wrap plug to check operation of the parallel port hardware. Each parallel signal is tested.

To run the Parallel Wrap Test:

1. Disconnect the parallel interface cable and install the wrap plug (P/N 1319128).
2. Select **Parallel Wrap Test** from the menu.
The power indicator blinks indicating the test is in progress. The test runs continuously until canceled.
Each time the test finishes, the screen updates. If the test passes, the Pass Count increases by 1, however if the test fails, one of the following messages appears for approximately three seconds:

```
Sync Busy Error          DMA Address Error
Byte Interrupt Request Error  DMA Interrupt Error
Strobe Interrupt Request Error  DMA Memory Error
Init Fail Error          DMA Background Error
Init Busy Error          Clear Init Rise Error
Init Rise Error          False Init Rise Error
Host Busy Error          Autofeed Rising Interrupt Error
RAM Data FF Error        Clear Autofeed Rise Error
RAM Data AA Error        False Autofeed Rise Error
RAM Data 00 Error        Autofeed Falling Interrupt Error
RAM Data 55 Error        Clear Autofeed Fall Error
DMA Count Error
```

Once the maximum count is reached the test stops. The power indicator goes on solid and the final results are displayed.

3. Press **Return** or **Stop** to exit the test.

Serial Wrap Test

Use this test to check the operation of the Serial Port Hardware using a wrap plug. Each signal is tested. Only displayed if the printer is configured with a standard serial port. If a serial port is available in the PCI slot 1, the Serial 1 Wrap appears.

To run the Serial Wrap Test:

1. Disconnect the serial interface cable and install the wrap plug.
2. Select the appropriate Serial Wrap Test from the menu: **Serial Wrap**, **Serial 1 Wrap**, **Serial 2 Wrap**, or **Serial 3 Wrap**. P and F represent the same numbers for DRAM.
The power indicator blinks indicating the test is running.
3. This test runs continuously unless canceled by pressing **Return** or **Stop**.

Each time the test finishes, the screen updates with the result. If the test passes, the Pass Count increases by 1, however if the test fails, one of the following failure messages appears for approximately three seconds and the Fail Count increases by 1:

Receive Status Interrupt Error	Data Error
Status Error	Data 232 Error
Receive Data Interrupt Error	Data 422 Error
Transmit Data Interrupt Error	FIFO Error
Transmit Empty Error	DSR Error
Threshold Error	DSR PIO Error
Receive Data Ready Error	DSR Interrupt Error
Break Interrupt Error	CTS Error
Framing Error	CTS PIO Error
Parity Error	CTS Interrupt Error
Overrun Error	

Once the maximum count is reached the test stops. The power indicator goes on solid and the final results are displayed.

DUPLEX TESTS

These tests display if a duplex option is installed.

Quick Test

This test verifies if the Duplex Option Top Margin is set correctly. This test prints a duplexed version of the Quick Test Page that can be used to adjust the Top Margin for the backside of the duplexed page. You can run one duplexed page (Single) or continue printing duplexed pages (Continuous) until **Return** or **Stop** is pressed.

You must use either Letter or A4 paper.

To run the Duplex Quick Test:

1. Select **Quick Test** from the DUPLEX TESTS menu.
2. Select **Single** or **Continuous**.
 - The single Duplex Quick test cannot be canceled.
 - The printer attempts to print the Quick Test Page from the default paper source. If the default paper source only supports envelopes, then the page is printed from Tray 1.
 - Check the Quick Test Page for the correct offset between the placement of the first scan line on the front and back side of a duplexed sheet.
 - If adjustment is necessary, the Top Margin Offset must be adjusted first. The range of the adjustment is -25 to +25. The Duplex Top Margin Offset range is -20 to +20.
 - Adjustment of this setting lets you shift up or down the position of the Top Margin. Changing this parameter by 1 unit moves the margin 1/100 inch. A positive offset moves the text down the page and widens the top margin, while a negative offset moves the text up the page and narrows the top margin.
3. Press **Return** or **Stop** to exit the test.

Check the Top Margin Offset of the base printer.

Top Margin

Modification of this setting controls the offset between the placement of the first scan line on the front and back side of a duplex sheet.

Changing the value by 1 unit moves the margin by 1/100 inches. A positive value moves the text down the page and widens the top margin. A negative value moves the text up the page and narrows the top margin.

Sensor Test

This test determines whether or not the Duplex sensors and switches are working correctly.

Select **Sensor Test** from the DUPLEX TESTS menu.

Manually actuate each of the duplex sensors. When the sensor/switch is closed, **CL** (closed) displays, when the sensor/switch is open, **OP** (Open) displays.

- Duplex input sensor
- Duplex exit sensor

Press **Return** or **Stop** to exit the test.

INPUT TRAY TESTS

Feed Test

This test lets you observe the paper path as media is feeding through the printer. The upper front door, used to access the print cartridge, cannot be opened during the feed test. To observe the paper path, you must open the lower front door, used to access the envelope feeder or MPF. No information is printed on the feed test pages since the laser isn't engaged during this test.

Note: This test can run using any of the paper or envelope sizes supported by the printer. The pages are placed in the default output bin, however, the Feed Test menu lets you select the input source.

To run the Input Tray Feed Test:

1. Select **Input Tray Feed Test** from the INPUT TRAY TESTS menu.
2. Select the input source from the sources displayed on the Feed Test Menu. All installed sources are displayed.
3. Select either **Single** (feeds one sheet of media from the selected source) or **Continuous** (continues to feed from the selected source until **Return** or **Stop** is pressed).
4. Press **Return** or **Stop** to exit test.

Sensor Test

This test can be used for either 500-sheet trays or 2000-sheet trays.

500-sheet trays

To run the Sensor Test for 500-sheet trays:

1. Select **Sensor Test** from the INPUT TRAY TESTS menu.
 - Sensor *L1*=Input Tray level/empty Sensor 1
 - Sensor *L2*=Input Tray level/empty Sensor 2
 - Sensor *P*=Input Tray Pass Thru Sensor
2. Once this message appears, you can manually actuate each sensor. The tray empty sensor can be actuated by hand, however a sheet of paper can be used to cover the pass thru sensor. When the sensor is closed, *CL* displays, when the sensor is open, *OP* appears.

Tray sensors are supported by the following sources:

Source	L1	L2	Pass thru sensor
Tray 1	Yes	Yes	Not present
Tray 2 ¹	Yes	Yes	Yes
Tray 3 ¹	Yes	Yes	Yes
Tray 4 ¹	Yes	Yes	Yes
Multipurpose Feeder	Yes	Not present	Not present
¹ 2000-sheet trays may be in this position. See “2000-sheet trays” .			

3. Press **Return** or **Stop** to exit the test.

2000-sheet trays

Use this test to determine if the 2000-Sheet Tray sensors are working correctly.

1. Select **Sensor Test** from the menu for the tray you want to test.

The following is displayed:

```
<input tray> EM=OP
NE=OP LE=OP SC=OP
```

The selected tray is displayed on line 1 <input tray> either Tray 1, 2, 3, or 4.

EM =trays empty sensor
 NE =trays near empty sensor
 LE =trays paper level sensor
 SC =input trays side cover sensor

2. Manually actuate the bin sensor by moving the flag in and out of the sensor. OP (Open) appears when the flag is out of the sensor, or CL (Closed) when the flag is in the sensor.

OUTPUT BIN TESTS

Feed Test
 Feed to all Bins
 Diverter Test
 Sensor Test

Feed Test

Note: If the “Configure Bins” printer setting is link rather than mailbox, the printer selects its own internal bin linking regardless of which output bin is selected for the feed test.

This test verifies that media can be fed to a specific output bin. No information is printed on the media because the printhead is not turned on during this test.

To run the Output Bin Feed Test:

1. Select **Feed Test** from the OUTPUT BIN TESTS menu.
2. Select the output bin you want the paper to exit into. All output bins installed on the printer are shown on the feed test menu.
For example, **Standard Bin**.
3. Select either **Single** (one sheet of media feeds to the selected output bin) or **Continuous** (media continues feeding to the selected output bin) until **Return** or **Stop** is pressed.
4. Press **Return** or **Stop** to exit the test.

Feed to All Bins

One page is fed to every bin, including the finisher, if available. The test runs continuously until **Return** or **Stop** is pressed.

Diverter Test

This test checks the operation of each mailbox output diverter. Also if more than one 5-Bin mailbox option is installed, the test checks all of the diverters installed on the printer.

When the test is selected from the Diagnostics Menu *Diverter Test Running* is displayed.

This is a single test and ends upon completion.

Sensor Test

This test verifies if the output bin sensors are working correctly.

The following Output options, if installed, are supported by this test.

Standard Bin
Output Expander
5-Bin Mailbox

To run the Output Bin Sensor Test:

1. Select **Sensor Test** from the menu.
2. Select the bin you want to test.
 - If Standard Bin is selected the following is displayed.

```
Standard Bin
F=OP
```

F =Standard Bin Output Bin Full Sensor

- If Output Expander is selected the following is displayed:

```
<output bin>
P=OP F=OP NF=OP
```

P =Output Expander Pass Thru Sensor.

F =Output Expander Full Sensor

NF =Output Expander Near Full Sensor.

- If 5-Bin Mailbox is selected the following is displayed:

```
<output bin>
P1=OP P2=OP L=NL
```

P1 =5-Bin Mailbox first Pass Thru Sensor.

P2 =5-Bin Mailbox second Pass Thru Sensor.

L =5-Bin Mailbox output level sensor where:

EM indicates the bin is empty.

NL indicates the bin contains media but the bin is not near full nor full.

NF indicates the bin is near full.

FL indicates the bin is full.

3. Once the selection is displayed you can manually actuate the sensor you want to test. When the sensor is closed (CL) displays, and when the sensor is open (OP) displays.
4. To exit the test press **Return** or **Stop**.

FINISHER TESTS

Staple Test

This test verifies the operation of the staple mechanism in the finisher.

To run the Staple Test:

1. Select **Staple Test** from the Finisher Tests menu.
2. Select a destination bin.
The printer feeds eight pieces of media to the finisher and accumulates all eight pieces in the accumulator. After the last sheet is accumulated, the pack is stapled.

When the test is complete, the printer returns to the original screen.

Feed Test

This test verifies that media can be fed to a finisher output bin and then stapled.

To run the Finisher Feed Test:

1. Select **Feed Test** from the menu.
2. Select a destination bin.
The printer feeds eight pieces of media to the selected finisher output bin where they are stapled.
Note: No information is printed on the fed sheets as the laser is not engaged during this test.

This test cannot be canceled or terminated once the test has begun. When the test is complete the printer returns to the original screen.

Sensor Test

This test determines if the finisher sensors are working correctly.

To run this test:

1. Select **Sensor Test** from the Finisher Test menu.
 - If you Select **Media 1** from the menu the following is displayed and the sensors polled:

Media Path 1 testing.....

Once the sensors are polled, the following is displayed and the sensors are ready to test:

Media Path 1 S1=CL S2=CL

S1 =Punch Timing Sensor A
S2 =Punch Timing Sensor B

Once this screen is displayed you can manually actuate each of the sensors. When the sensor is closed, CL is displayed, when the sensor is open OP is displayed.

- If you select **Media 2** from the menu the following is displayed and the sensors polled:

Media Path 2
Testing.....

Once the sensors are polled the following is displayed and the sensors are ready to test.

Media Path 2
S3=CL S4=CL

S3 =Inverter Jam Sensor
S4 =Drop Timing Sensor

Once the screen is displayed you can manually actuate each of the sensors. When the sensor is closed, CL is displayed, when the sensor is open OP is displayed.

- If you select **Media 3** from the menu the following is displayed and the sensors polled:

Media Path 3
Testing.....

Once the sensors are polled the following is displayed and the sensors are ready to test:

Media Path 3
S5=CL

S5 =Exit Timing Sensor

Once the screen is displayed you can manually actuate the sensor. When the sensor is closed, CL is displayed, when the sensor is open OP is displayed.

- If you select **Media Level** from the menu the following is displayed and the sensors polled:

Media Level
Testing.....

Once the sensors are polled the following is displayed and the sensors are ready to test:

Media Level
S1=CL S2=CL

S1 =Paper Surface Sensor 1 (upper)
S2 =Paper Surface Sensor 2 (lower)

Once the screen is displayed you can manually actuate the sensor. When the sensor is closed, CL is displayed, when the sensor is open OP is displayed.

2. To exit the sensor test, press **Return** or **Stop**.

Hole Punch

Use this test to verify that media can be fed to the Finisher output bin and hole punched. Letter or A4 size media must be used in the source tray for this test. No information is printed on the feed test pages since the laser is not energized during this test. Eight sheets of paper are fed and holes punched with a three hole pattern.

To run the test in Diagnostics Mode:

1. Select **FINISHER TESTS** from the Diagnostics menu.
2. Select **Hole Punch**.

Press **Return** after the test is complete to exit the test.

BASE SENSOR TEST

Use the Base Sensor Test to determine that the sensors located inside the printer are operating correctly. The following sensors can be checked using this test:

- **Input – S1**
- **Input – S2**
- **In-Line media Sensor**
- **Fuser exit Sensor**

See “**Printer sensors**” on page 5-3 for locations for these sensors. See “**Cartridge contact assembly pin locations**” on page 5-4.

CAUTION: These sensors are near high voltage terminals to the print cartridge. Use a nonconducting item to toggle these switches and not your hand.

To run the Base Sensor Test.

1. Select **BASE SENSOR TEST** from the Diagnostics Mode.
OP for open and CL for closed are displayed.
2. Manually toggle the sensors by hand to verify that each sensor switches from open to closed.

DEVICE TESTS

Quick Disk Test

This test performs a non-destructive read/write on one block per track on the disk. The test reads one block on each track, saves the data, and proceeds to write and read four test patterns to the bytes in the block. If the block is good, the saved data is written back to the disk.

To run the Quick Disk Test:

1. Select **Quick Disk Test** from the Device Tests menu.
 - The power indicator blinks while the test is in progress.
 - Quick Disk Test/Test Passed displays if the test passes and the power indicator turns on solid.
 - Quick Disk Test/Test Failed displays if the test failed and the power indicator turns on solid.
2. Press **Go**, **Return**, or **Stop** to return to the Device Tests menu.

Disk Test/Clean

Warning: This test destroys all data on the disk and should not be attempted on a good disk. This test may run approximately 1½ hours depending on the disk size.

To run the Disk Test/Clean Test:

1. Select **Disk Test/Clean** from the Device Tests menu.
Files will be lost/Go or Stop? is displayed to warn the user that all contents on the disk will be lost.
2. To exit the test immediately and return to the Device Tests menu, press **Return** or **Stop**. To continue with the test, press **Go**.
If **Go** is selected, Disk Test/Clean/BAD:000000 00% is displayed. The screen updates periodically indicating the percentage of test completed and the number of bad blocks found.

3. The power indicator blinks during the test. The test can be canceled anytime during the test by pressing **Return** or **Stop**.
 - Once the test is complete, the power indicator turns on solid and a message displays.
 - `xxxx Bad Blocks/yyyy Usable` is displayed if fewer than 2000 bad blocks are detected. `xxxx` indicates the number of bad blocks and `yyyyyy` indicates the number of usable blocks.
 - `xxxx Bad Blocks/Replace Disk` is displayed if more than 2000 bad blocks are detected. The disk cannot be recovered because too many bad blocks exist on the disk.
4. Press **Go** or **Return** or **Stop** to return to the Device Tests menu.

Flash Test

This test causes the file system to write and read data on the flash to test the flash.

Warning: This test destroys all data on the flash because the flash is reformatted at the end of the test.

To run the Flash Test:

1. Select **Flash Test** from the Device Tests menu.
 - The power indicator blinks while the test is running.
 - `Flash Test/Test Passed` is displayed if the test passes and the power indicator turns on solid.
 - `Flash Test/Test Failed` is displayed if the test fails and the power indicator turns on solid.
2. Press **Go** or **Return** or **Stop** to return to the Device Tests menu.

PRINTER SETUP

Defaults

This setting is used by the printer to determine whether US or non-US factory defaults should be selected. The following printer settings have different US and non-US values:

Default values

Printer setting	US value	Non-US value
Paper size (paper feeding sources which do not have hardware size sensing capabilities)	Letter	A4
Envelope size (Envelope feeding sources which do not have hardware size sensing capability)	10 Envelope	DL Envelope
Fax paper size	Letter	A4
PCL symbol set	PC-8	PC-850
PPDS code page	437	850
Universal units of measure	Inches	Millimeters

Warning: Modification of the printer setting Defaults causes the NVRAM space to be restored to the printer's factory settings.

Reset Calibrat.

The Reset Calibration resets the TPS NVRAM values when initiated.

1. Select **Reset Calibration** from the Printer Setup Menu and the following screen displays:

Printer Setup Reset Calibration

Then the following screen is displayed:

Resetting Calibration

2. The printer returns to the previous screen when calibration is complete.

Page Count

The printer's page count can be changed by the Diagnostics Mode. The Color and Mono Page Count can be changed whenever the paper size sensing board is replaced.

Note: The Perm Page Count cannot be changed.

1. Select **Page Count** from the Printer Setup Menu.
2. Select either **Color Page Count**, **Mono Page Count** or **Perm Page Count** from the menu.

When you have made the selection, the following screen is displayed:

Color Page Count =1234567*

3. The left most digit blinks, indicating it is the first digit to be changed. To change the value, press either **Menu** until the desired value is displayed. Press **Select** to move to the next digit. The digit blinks. Continue modifying each digit using this method. To skip a digit and keep its current value, press **Select**.
4. When you have completed selecting the final digit, press **Select** and the count is stored in NVRAM.
5. Press **Return** to return to the Printer Setup Menu.
6. Select a new test or select **Exit Diagnostics** from the Diagnostic Menu.

Perm Page Count

The permanent page count can only be viewed from the operator panel and cannot be changed.

1. Select **Perm Page Count** from the menu.
2. The following screen will be displayed when permanent page count is selected:

Perm Page Count =1234567*

3. Press **Return** to return to the Printer Setup Menu.
4. Select a new test or select **Exit Diagnostics** from the Diagnostic Menu.

Serial Number

You can view the serial number.

Engine Setting x

Warning: Should not be changed without specific instructions from the next level support.

Model Name

You can view the model name.

Configuration ID

Warning: Should not be changed without specific instructions from the next level support.

The configuration ID is used to communicate characteristics of certain areas of the printer that cannot be determined by hardware sensors. The configuration ID is originally set when the printer is manufactured. However, it needs to be reset when the system board or paper size sensing board are replaced.

1. Select **Configuration ID** from the Printer Setup Menu.

The following screen is displayed:

Configuration ID =1234567*

2. Open the waste container door to locate a label above the waste container. The label contains the configuration ID.
3. The leftmost digit blinks, indicating it is the first digit to be changed. To change the value, press **Menu** until the desired value is displayed. Press **Select** to move to the next digit. The digit blinks. Continue modifying each digit using this method. To skip a digit, and keep its current value, press **Select**.
4. When **Select** is pressed after the final digit, the configuration ID is validated. If the ID is invalid, the invalid ID is displayed momentarily on the second line before the ID is displayed. If the ID is valid, then the ID is stored in NVRAM and the printer automatically begins POR to activate the new setting.

Note: The printer begins POR in the normal mode, not in the diagnostic mode.

Note: If a configuration ID has not been set, and Check Configuration ID displays, then upon entry into diagnostics, Configuration ID is the only diagnostic function displayed until a valid ID is entered.

Edge to Edge

Turn Edge to Edge printing on or off.

Cal Ref Adj

Warning: Should not be changed without specific instructions from the next level support.

EP SETUP

EP Defaults

The EP Defaults is used to restore each of the printer settings contained in the EP Setup menu to their factory default value.

To restore the EP Setup settings to factory defaults, select **Restore**.

To exit the menu without restoring the settings to the factory defaults, select **Do Not Restore**.

Fuser Temp

Warning: Should not be changed without specific instructions from the next level support.

DC Charge Adjust

Warning: Should not be changed without specific instructions from the next level support.

Dev Bias Adj

Warning: Should not be changed without specific instructions from the next level support.

Transfer Adjust

Warning: Should not be changed without specific instructions from the next level support.

ERROR LOG

View Log

The error log provides a history of printer errors. The error log contains the 12 most recent errors. The most recent error appears in position 1 and the oldest error appears in position 12 (if 12 errors have occurred). If an error occurs after the log is full, the oldest error is discarded. Identical errors in consecutive positions in the log are entered. All 2xx and 9xx error messages are stored in the error log.

To view the Error Log:

1. Select **Display Log** from the Error Log Menu.

The error log displays on three screens, but only four entries display at a time. To move to the next screen or the previous screen, press **Menu**. For example:

1-200	2-251
3-202	4-202

5-202	6-202
7-202	8-200

9-202	10-202
11-201	12-000

In this example, the last error was a 200 error. Position 12, in this example, is filled with 000 which indicates no codes were recorded. Only eleven codes were recorded since the log was cleared.

2. Press **Return** or **Stop** to exit the Error Log.

Clear Log

To clear the Error Log:

1. Select **Clear Log** from the Error Log menu.
2. Select **YES** to clear the Error Log or **NO** to exit the Clear Log menu.
If **YES** is selected, the Empty Error Log displays on the screen.
3. Press **Return** or **Stop** to exit the Clear Log menu.

High-capacity input tray tests

HCIT Standalone Test Mode

This test lets you check out and test the HCIT (2000-Sheet High Capacity Input Tray) without removing any option or the base printer mounted above the optional HCIT.

Note: During normal operation, the red LED on the HCIT system board blinks or flashes on for one second and off for one second.

Dip Switch Settings

Do the following steps to set and run the Test/Diagnostic:

1. Use the dip switch settings table to determine the settings (DSW1 thru DSW4) on the HCIT Control Board for the test you want to run.
2. Turn the HCIT power off by moving the LVPS slide switch to the left position.
3. Press and hold the Push Button Switch PBSW1 while moving the LVPS slide switch to the right position. The red LED on the HCIT Control board comes on.
4. Press PBSW1 to feed paper.
5. Press PBSW1 to stop feeding paper.

Dip switch settings table

DSW1	DSW2	DSW3	DSW4	Mode
Off	Off	Off	N/A	Set for shipping
Off	Off	On	N/A	The adjustment for the Mirror Reflection Sensors must be performed anytime the sensors are replaced.
Off	On	Off	N/A	EEPROM Initialize
Off	On	On	N/A	Not used
On	Off	Off	N/A	Paperless Operation Mode
On	Off	On	N/A	Self Operation Mode
On	On	Off	N/A	Standalone Feeding Operation Mode
On	On	On	N/A	Not used

4. Repair information

Warning: Read the following before handling electronic parts.



Handling ESD-sensitive parts



Many electronic products use parts that are known to be sensitive to electrostatic discharge (ESD). To prevent damage to ESD-sensitive parts, use the following instructions in addition to all the usual precautions, such as turning off power before removing logic boards:

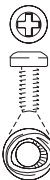

- Keep the ESD-sensitive part in its original shipping container (a special “ESD bag”) until you are ready to install the part into the machine.
- Make the least-possible movements with your body to prevent an increase of static electricity from clothing fibers, carpets, and furniture.
- Put the ESD wrist strap on your wrist. Connect the wrist band to the system ground point. This discharges any static electricity in your body to the machine.
- Hold the ESD-sensitive part by its edge connector shroud (cover); do not touch its pins. If you are removing a pluggable module, use the correct tool.
- Do not place the ESD-sensitive part on the machine cover or on a metal table; if you need to put down the ESD-sensitive part for any reason, first put it into its special bag.
- Machine covers and metal tables are electrical grounds. They increase the risk of damage because they make a discharge path from your body through the ESD-sensitive part. (Large metal objects can be discharge paths without being grounded.)
- Prevent ESD-sensitive parts from being accidentally touched by other personnel. Install machine covers when you are not working on the machine, and do not put unprotected ESD-sensitive parts on a table.
- If possible, keep all ESD-sensitive parts in a grounded metal cabinet (case).
- Be extra careful in working with ESD-sensitive parts when cold-weather heating is used because low humidity increases static electricity.

Screw identification table

The following table contains screw types, locations, and quantities necessary to service the printer. Pay careful attention to each screw type location when doing removals. You must install the correct screw type in each location during reassembly.

Reference number	Screw type	Location	Purpose	Qty
002 	4-40 machine	Parallel connector to shield	Attach	2
102 	M3.5x8mm thread cutting	Cartridge guides to upper frame	Attach	8
		Upper front cover to cartridge guides	Attach	4
		Front cover pivot to front upper cover	Attach	2
		Front left light shield to upper front cover	Attach	1
121 	M3.5x6mm machine	LVPS to lower frame	Mounting	7
		Right rear cover to LVPS	Attach	1
		HVPS standoffs to upper frame	Attach	4
232 	M3x6mm Taptite metal thread forming	Ground cable to right front cover support and upper frame.	Attach	2
		Ground cable to bottom support plate and engine card shield	Attach	2
		Back lamp brackets to fuser frame	Attach	2
		Front lamp brackets to fuser frame	Attach	2
		Blank INA covers to RIP shield	Mounting	2
		RIP card ground shield to RIP shield	Mounting	5
		RIP shield to engine shield	Mounting	4
		RIP card to RIP shield	Mounting	12
		Engine card to engine shield	Mounting	6
		RIP shield cover to RIP shield	Mounting	8
		V-block plates to upper frame	Mounting	2
		Ground cable strap to RIP ground shield	Attach	1

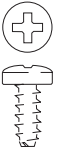
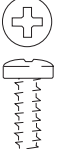
Reference number	Screw type	Location	Purpose	Qty
312 	M2.9x6mm Plastite	Front access door assembly	Mounting	3
		Door handle to cover	Mounting	2
		Detent housing to cover	Mounting	1
		ITU switch housing to light shield	Attach	1
		Duplex baffle to lower right door	Attach	4
		Front and rear latches to lower right door	Mounting	2
		Bias latch cover to door	Attach	1
		MPF asm to MPF door	Attach	6
		Support bracket to MPF door	Attach	4
		MPF cable cover to door asm	Mounting	1
		MPF latch support brackets to upper frame	Attach	2
		Voltage cable to terminal (BOR/ITU) black	Attach	1
		Voltage cable to terminal (BOR/ITU) cyan	Attach	1
		Voltage cable to terminal (BOR/ITU) magenta	Attach	1
		Voltage cable to terminal (BOR/ITU) yellow	Attach	1
323 	M3.5x1.35mm Plastite 8 long	Frame support back plate to lower frame	Attach	2
		Door latch catch to frame	Attach	2
		Transfer HVPS to lower frame	Mounting	1
		Fuser top duct to lower frame	Attach	1
		Right front cover support to lower frame	Attach	1
		Front lower left cover to lower frame	Attach	1
		Front left handle cover asm to lower frame	Attach	4
		Front lower right cover to lower frame	Attach	1
		Front right handle cover asm to lower frame	Attach	4
		Right front cover to lower frame	Attach	2
		Left lower cover to lower frame	Attach	2
		Left upper cover asm to lower frame	Attach	2
		Left upper cover asm to upper frame	Attach	1
		Left lower pivot to lower frame	Attach	2
		Left upper pivot to left lower cover	Attach	1
		Rear cover to lower frame, left cover	Attach	6
		Rear fan cover to lower frame and top cover	Attach	4
		Top cover asm to upper front cover	Attach	3
		Top cover asm to RIP shield	Attach	1
		ITU light shield asm to upper front guide ITU	Attach	1
		Ribs to upper redrive door	Mounting	5
		Upper door hinges to upper frame (redrive)	Mounting	2
		Inner redrive asm to upper frame (redrive)	Mounting	2
		Developer HVPS to cartridge contact asm	Mounting	4
		Engine card shield to frame	Mounting	5
		BOR drive asm to upper frame	Mounting	1

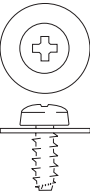
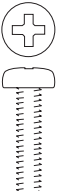
Reference number	Screw type	Location	Purpose	Qty
323 (continued) 	M3.5 x 1.35mm Plastite 8 long (continued)	ITU drive asm to lower frame	Mounting	3
		Fuser drive asm to lower frame	Mounting	4
		Vacuum top duct to lower frame	Mounting	2
		Toner shield to lower frame	Attach	4
		Upper deflector to lower frame (PF XPORT)	Mounting	2
		VTB asm to lower frame (PF XPORT)	Mounting	2
		Inner deflector to VTB assembly (PF XPORT)	Attach	1
		Jam access spring to VTB asm (PF XPORT)	Attach	1
		500 pick assembly to lower frame	Mounting	3
		Paper size sensing assembly to lower frame	Mounting	1
		Paper level sensing assembly to lower frame	Mounting	3
324 	M3.5x10mm Plastite thread forming	Transfer HVPS/RIP fan asm to RIP shield	Attach	1
		Front left light shield to left upper cover asm and top cover	Attach	1
		Front right light shield to right front cover support and top cover	Attach	1
		Cartridge drive assemblies to upper frame	Mounting	12
		Upper door hinges to upper frame (redrive)	Attach	2
		Inner redrive assembly to upper frame	Mounting	2
412 	2.9x5.2mm Plastite	Hinge restraint to door (MPF) SEMS	Attach	1
423 	M3.5x9 Plastite	Tray bias bellcrank to tray	Mounting	1
484 	M3.5x14 Machine Panhead	Printhead to upper frame	Mounting	12

Removal procedures

CAUTION: Remove the power cord from the printer or electrical outlet before you connect or disconnect any cable or electronic board or assembly for personal safety and to prevent damage to the printer. Disconnect any connections between the printer and PCs/peripherals. The printer weighs 47.7 kg (105 lb) and requires at least two people to lift it safely. Make sure your fingers are not under the printer when you lift or set the printer down.

Note: Some removal procedures require removing cable ties. You must replace cable ties during reassembly to avoid pinching wires, obstructing the paper path, or restricting mechanical movement.

Top cover assembly removal

1. Remove the redrive cap.



2. Remove the right light shield screw type "324" (A) and "323" (B) and release tab (C) from the frame slot.

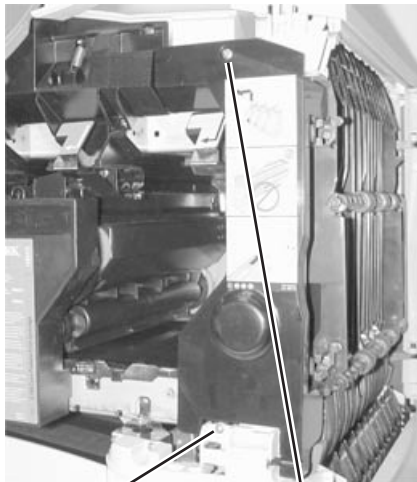

B(323)

A(324)

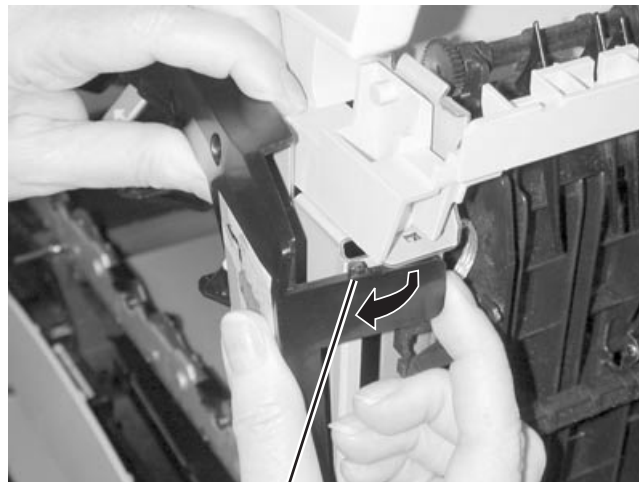

C

3. Remove the right light shield.

4. Remove the operator panel bezel.



Bezel

5. Remove the top cover mounting screws (D) from the front of the printer.

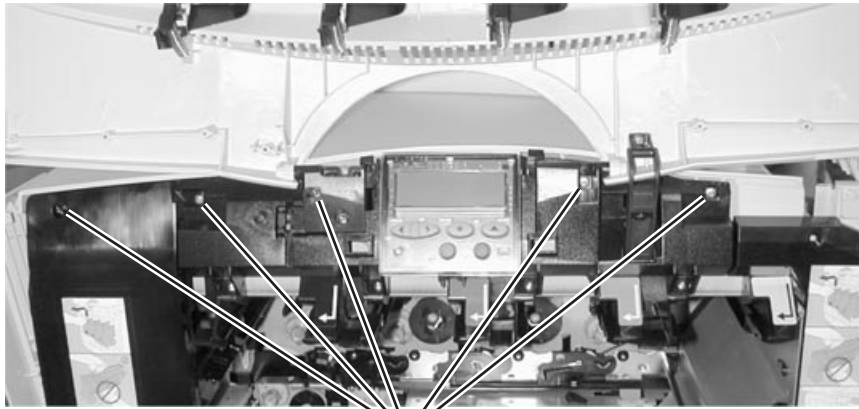

D

6. Remove the three top cover screws (E) type "323" on page 4-3 from the rear and the screw (F) from the left side of the printer.

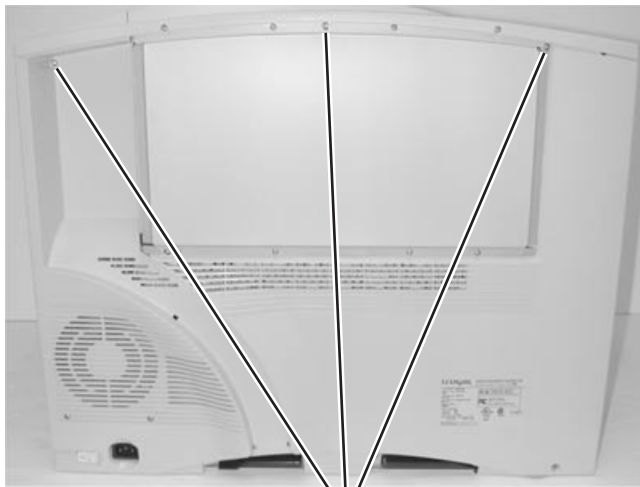

E(323)



F(323)

7. Remove the flag retainer (G) from the top cover.

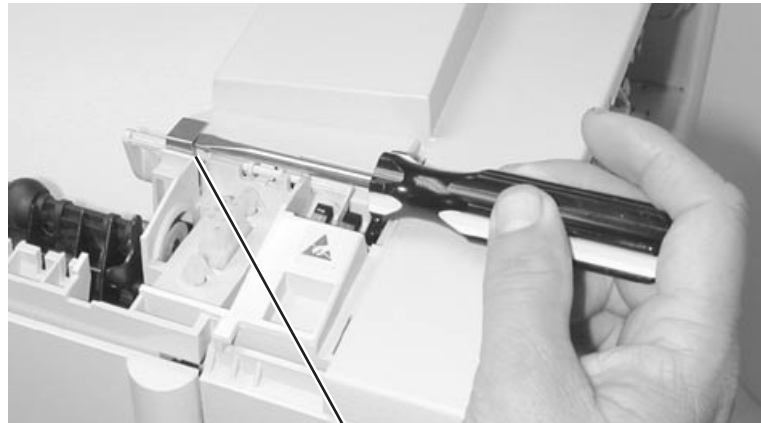

G

8. Under the top cover, unclip the bin full sensor (H). Tilt the sensor and lower it through the top cover.
9. Remove the upper option autoconnect (I).

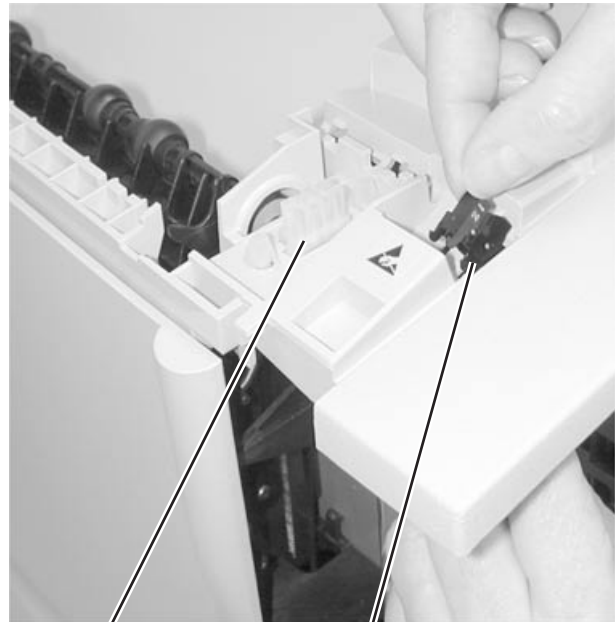
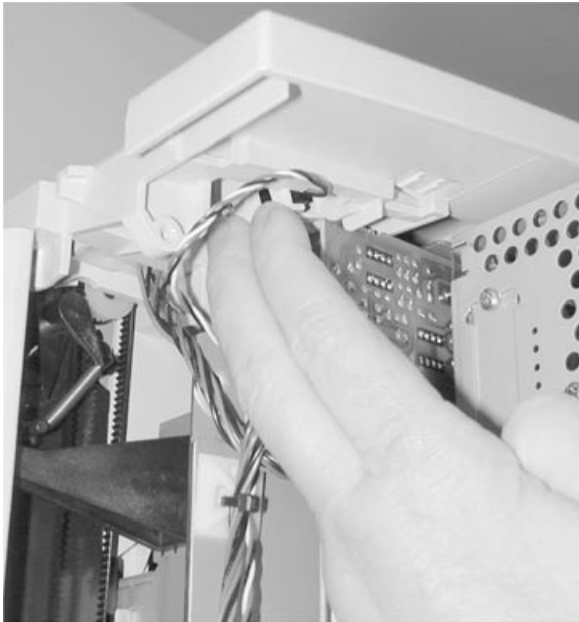

H

I

10. Remove the top cover.

Rear fan cover removal

See **“Rear fan cover”** on page 7-5 for the part number.

1. Remove the rear cover. See **“Rear cover removal”** on page 4-8.
2. Remove the rear fan cover screw type **“323”** (A) and remove the rear fan cover.



Rear cover removal

See **“Rear cover”** on page 7-5 for the part number.

1. Remove the rear cover screw type **“323”** (A).
2. Open the MPF, remove the rear cover screw type **“323”** (B), and remove the rear cover.

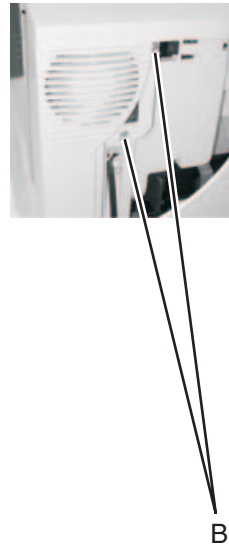
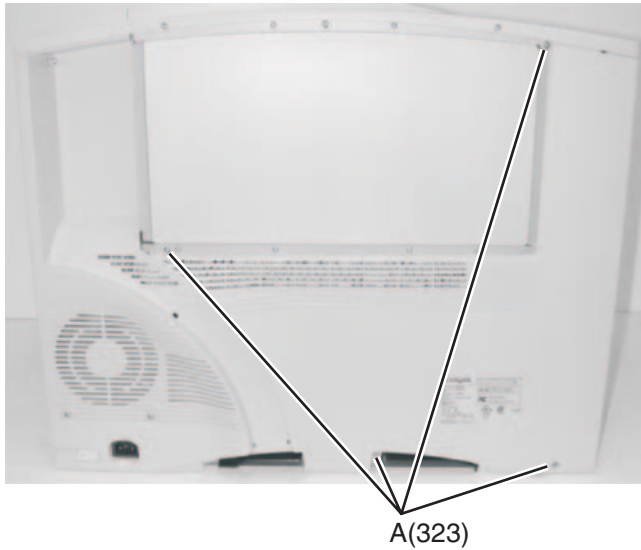

Front right handle cover assembly removal

See **“Front right handle cover assembly”** on page 7-3 for the part number.

1. Open the front cover.
2. Remove the light shield screw type **“324”** (A) and screw type **“323”** (B) and release tab (C) from the frame slot.

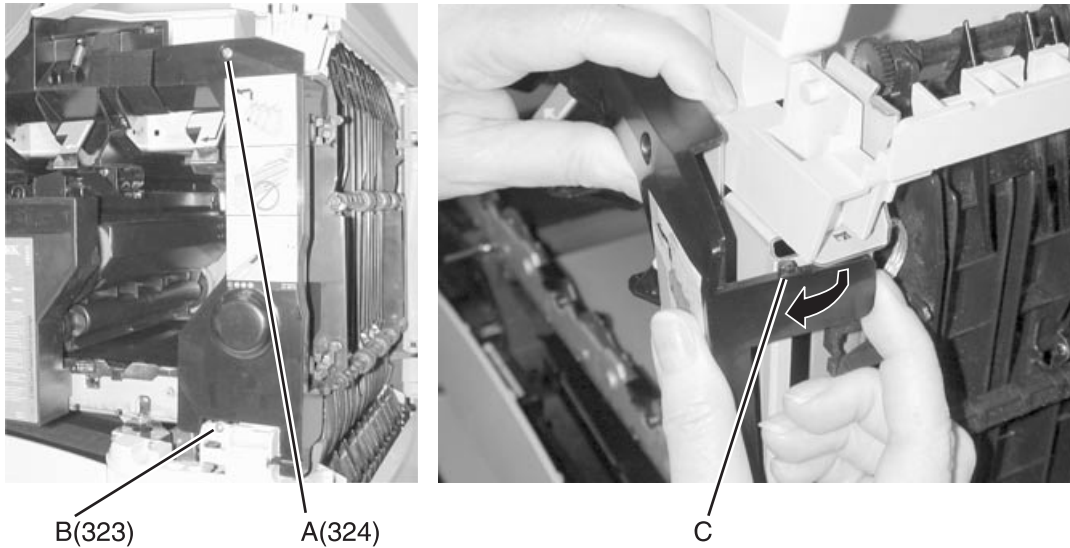

3. Remove the light shield.
4. Remove the front right handle cover assembly screw type **“323”** (C) and remove the assembly.

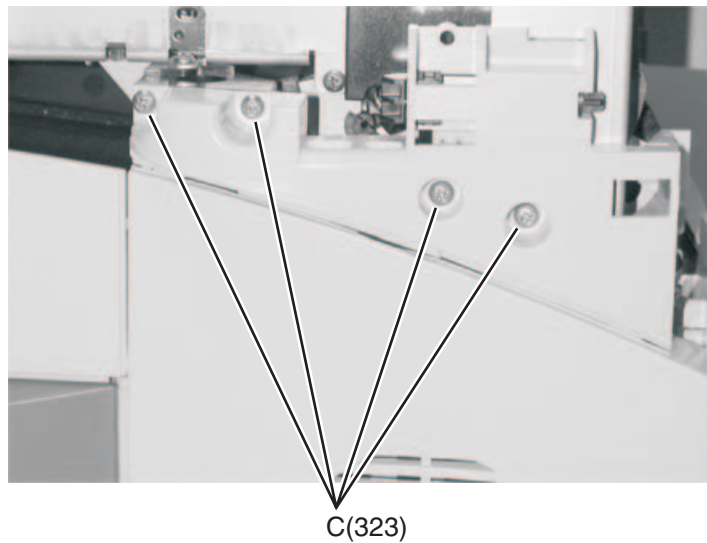

Front left handle cover assembly removal

See **“Front left handle cover assembly”** on page 7-3 for the part number.

1. Open the front cover.
2. Remove the front left handle cover assembly screw type **“323”** (A) and remove the assembly.

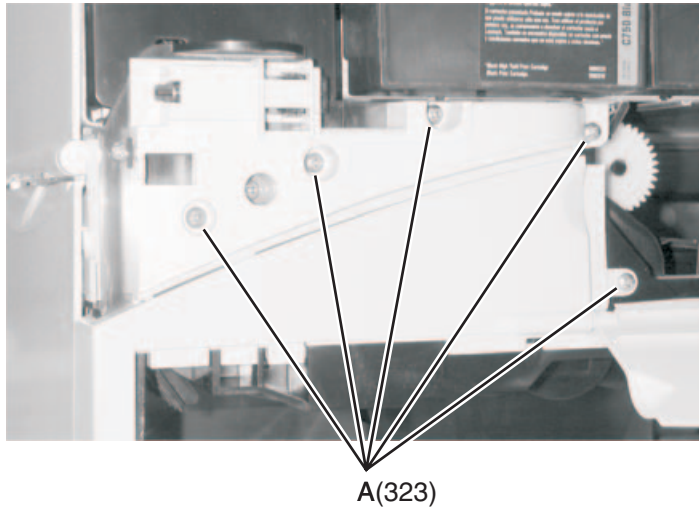

Front cover assembly removal

See **“Front cover assembly”** on page 7-3 for the part number.

1. Open the front cover.
2. Remove the detent post tension spring (A).

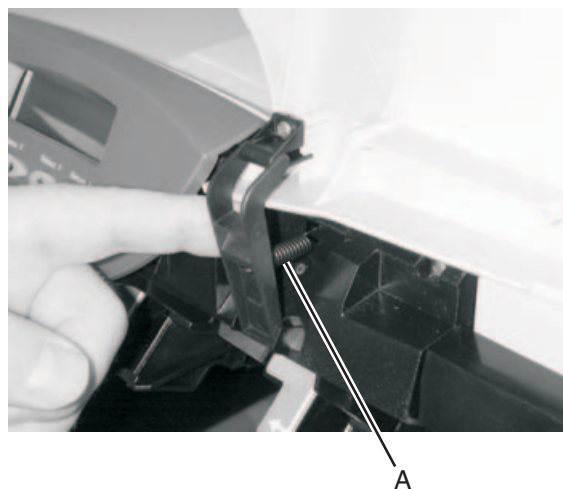

3. Remove the bezel (B).

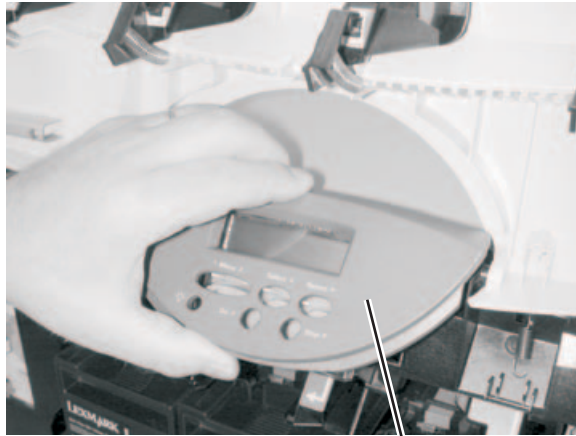

B

4. Hold the front cover and remove the two screws type "102" (C) from the upper front pivot cover.

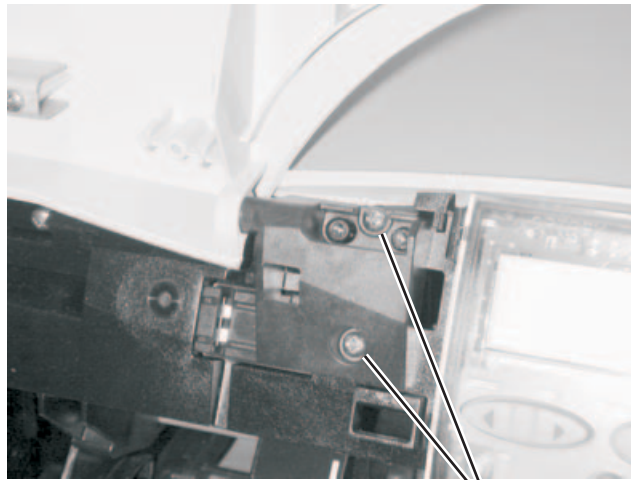

C(102)

5. Remove the front cover assembly.

Lower right door assembly removal

See “**Lower right door assembly**” on page 7-3 for the part number.

1. Open the lower right door assembly.
2. Remove the front right handle cover assembly. See “**Front right handle cover assembly removal**” on page 4-9.
3. Remove the screw (A) on the lower right front cover.



A(323)

4. Close the paper path access door and tape front jam access door (B) if tape is available, to help hold the door in place.
The spring loaded door is difficult to reassemble. Avoid disassembly of the door, unless you need to replace the paper path access door.



B

5. Loosen the two screws (C).

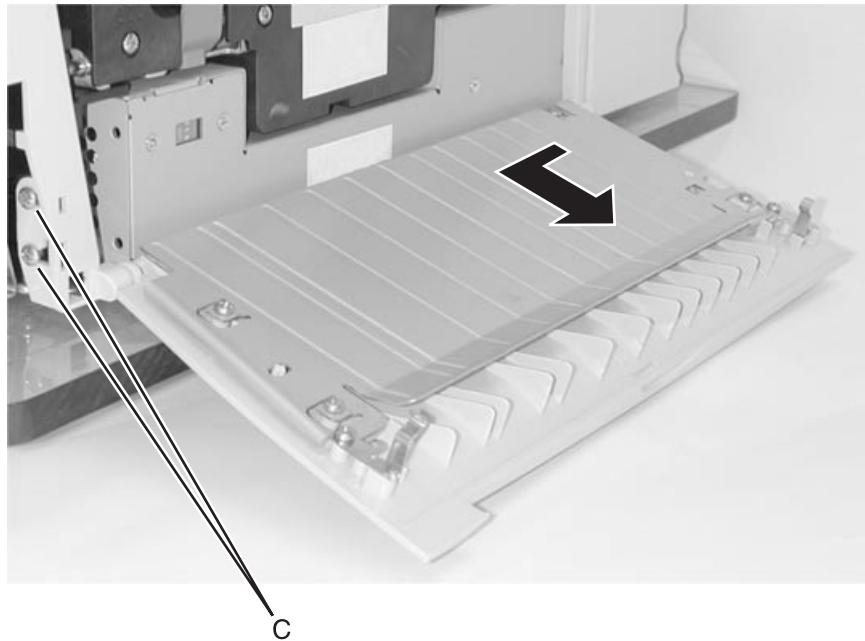

6. Remove the lower right door assembly.

Left lower cover removal

1. Remove the lower jam access door assembly. See **“Lower jam access door assembly removal”** on **page 4-14**.
2. Remove the left lower cover screw type **“323”** (A) and remove the cover.

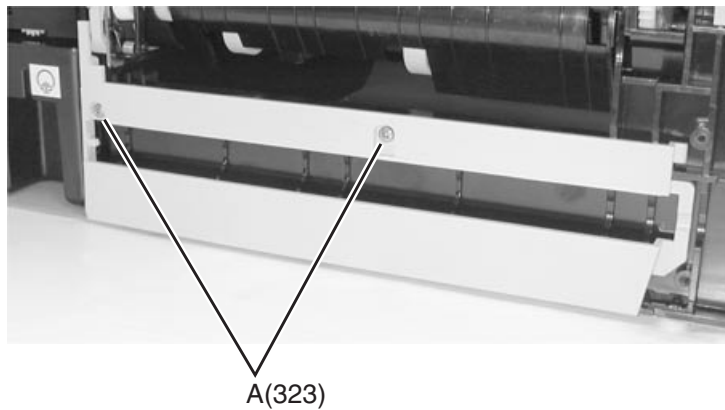

Lower jam access door assembly removal

See **“Cover, left lower” on page 7-5** for the part number.

1. Remove the front left handle cover assembly. See **“Front left handle cover assembly removal” on page 4-10**.
2. Remove the lower jam access door assembly screw type **“323” (A)** and remove the door.

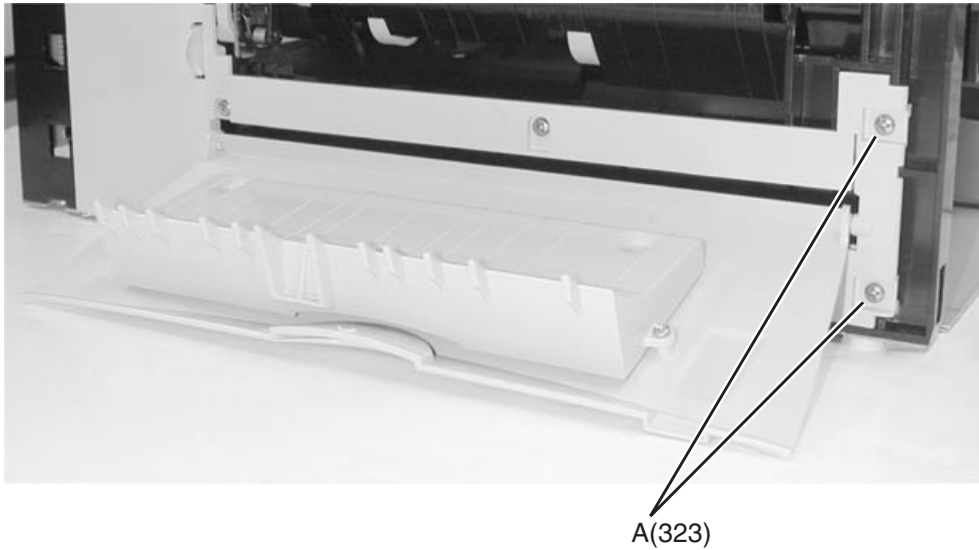

Redrive door removal

See **“Redrive door” on page 7-16** for the part number.

1. Open the redrive door.
2. Loosen the redrive door upper hinge screw type **“324” (A)**.
3. Lift the redrive door from the hinge (B) and remove the redrive door.

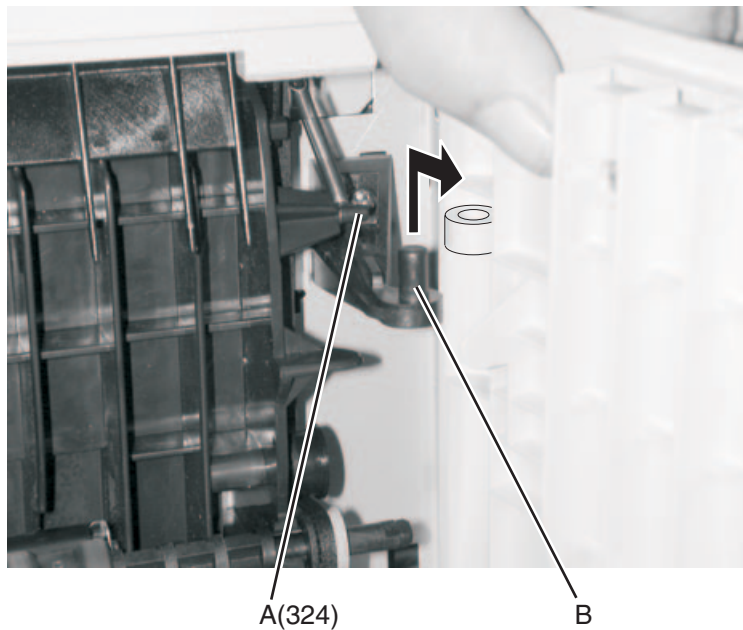

Paper path access door cover removal

See **“Paper path access door” on page 7-3** for part number.

1. Remove the paper tray.
2. Remove the front left handle cover assembly. See **“Front left handle cover assembly removal” on page 4-10**.
3. Open the paper path access door, carefully remove screw (A) type **“323” on page 4-3**, and remove the door.



A(323)

4. Remove the front lower left cover and door.
Do not lose the spring.

Front lower left cover removal

See **“Front lower left cover”** on page 7-3 for part number.

1. Remove the paper tray.
2. Remove the front left handle cover assembly. See **“Front left handle cover assembly removal”** on page 4-10.
3. Open the paper path access door, carefully remove screw (A) type **“323”** on page 4-3, and close the door.

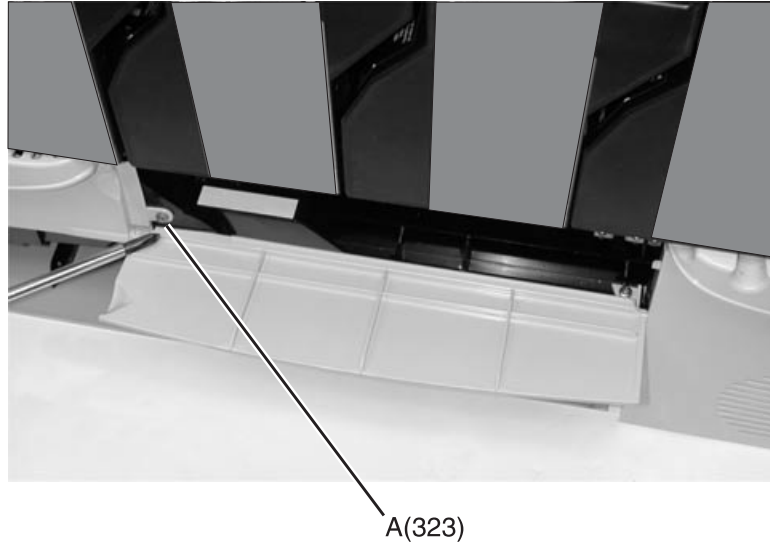

4. Close the paper path access door and tape front jam access door (B) if tape is available, to help hold the door in place.
The spring loaded door is difficult to reassemble. Avoid disassembly of the door, unless you need to replace the paper path access door.

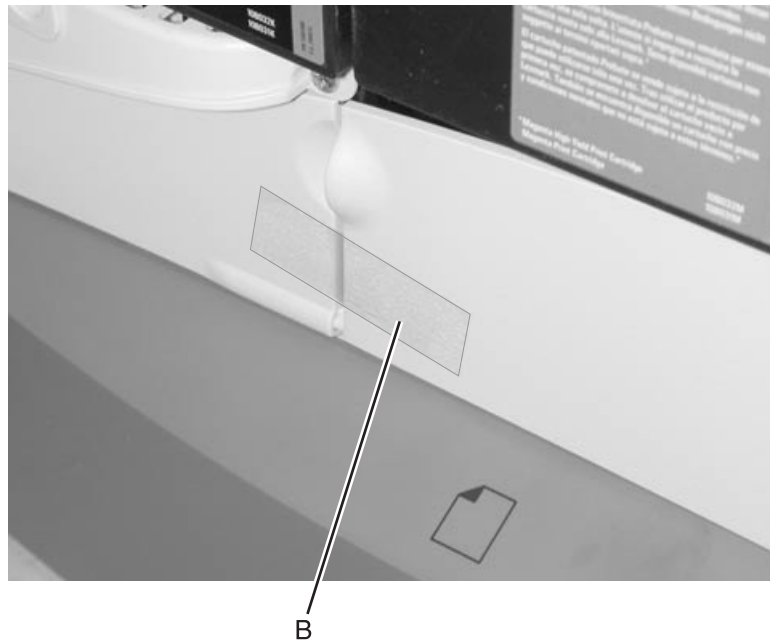

5. Remove the front lower left cover with the paper path door attached.

Autocompensator pick assembly removal

1. Remove all cartridges.
2. Remove the ITU. See **"ITU assembly removal"** on page 4-37.
3. Remove tray 1.
4. Remove the second transfer roll. See **"Second transfer roll removal"** on page 4-79.
5. Remove the transfer plate. Lifting and rotating the right edge of the plate up to a 45° angle will release the transfer plate. Remove the grounding strap (A) attached to the bottom of the transfer plate.

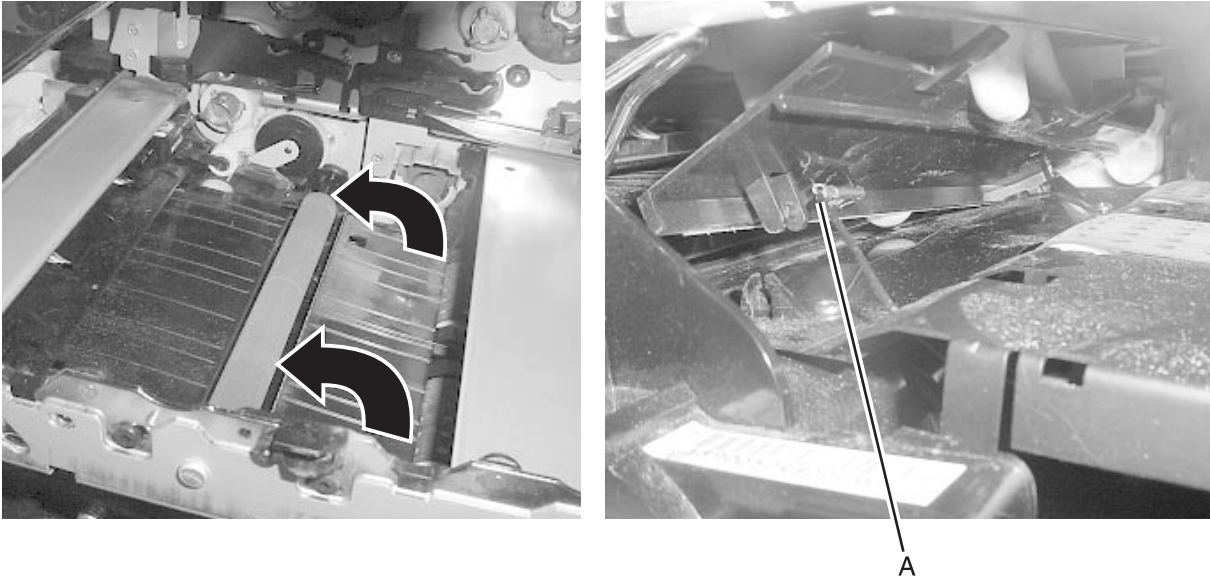

6. Remove the black mylar piece by removing the two screws (B) or cutting the cable tie.

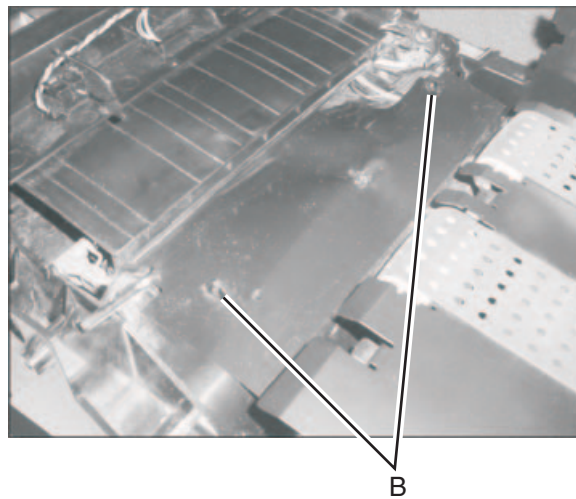

7. Remove the five screws "323" (C) and remove the lower left cover and the jam access door.

Warning: Be careful not to lose the access door spring.

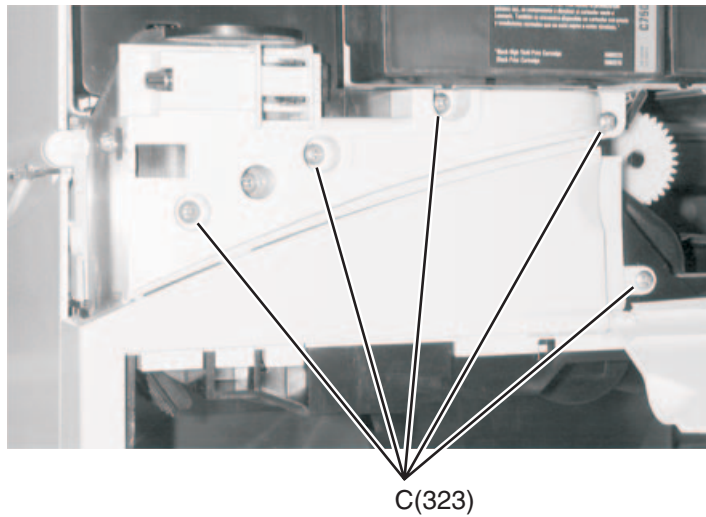

8. Remove the pin (D) that holds in the MPF swing arm assembly.

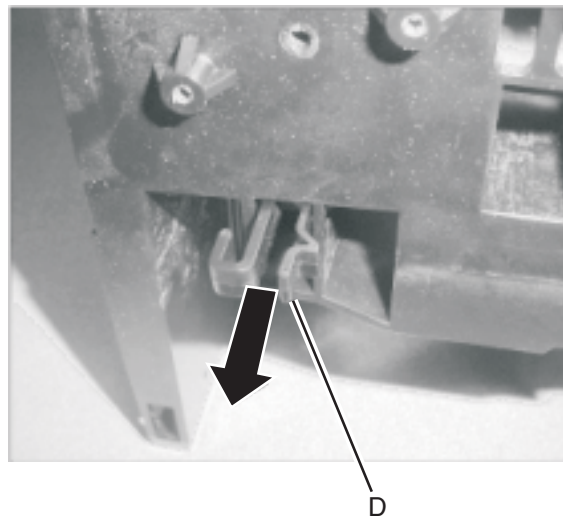

9. Remove the MPF swing arm assembly (E).

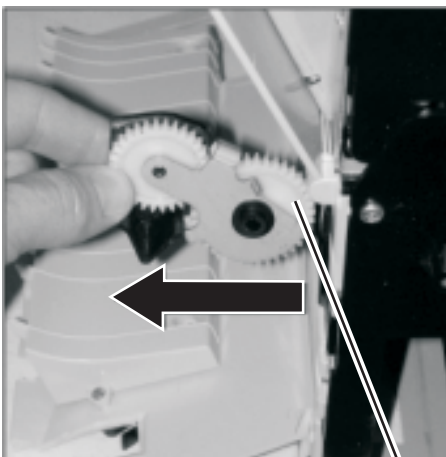

E

10. Remove paper level sensor. There are two screws located under the back VTB belt. Remove both of them along with a third that is located at the rear pivot point for the transfer plate (F). This allows the paper level assembly to drop into the cavity that the tray is inserted into. Disconnect the cable from the paper level sensor. Pull the paper level sensor cable up through the opening. Remove the paper level sensor assembly.

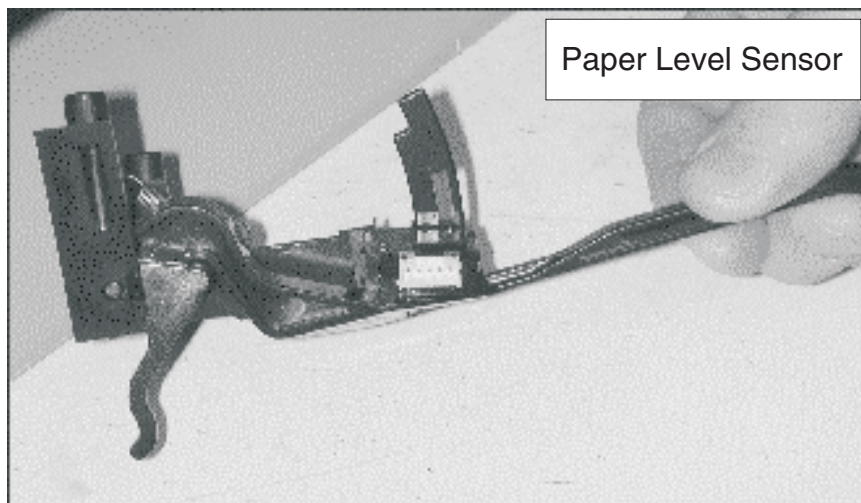
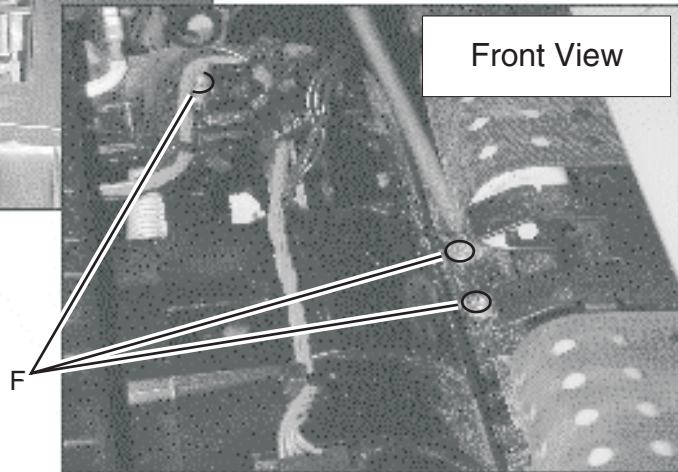
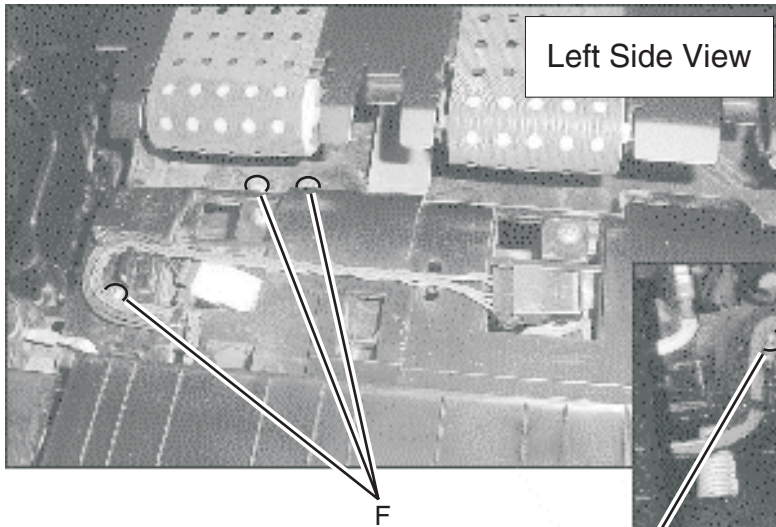

11. Disconnect the pick motor and the transparency sensor connectors (G).

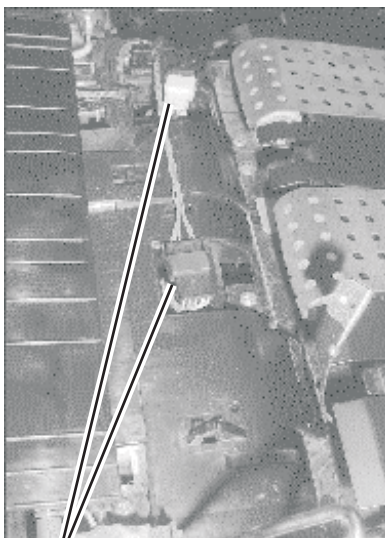

G

12. Remove four screws (H) holding the pick assembly in place.

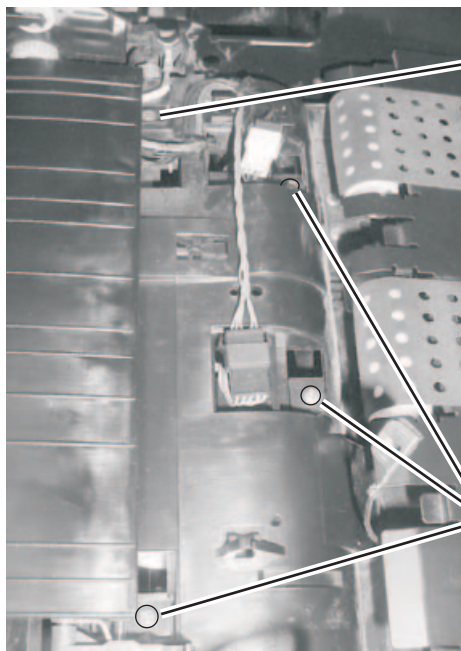

DO NOT REMOVE THIS SCREW

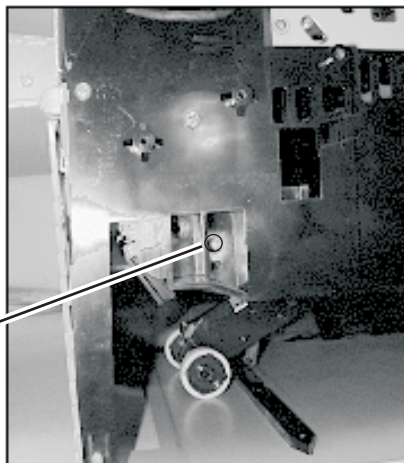

H

13. Push the bellcrank (I) in to allow the pick arm to fall to the bottom of the tray.

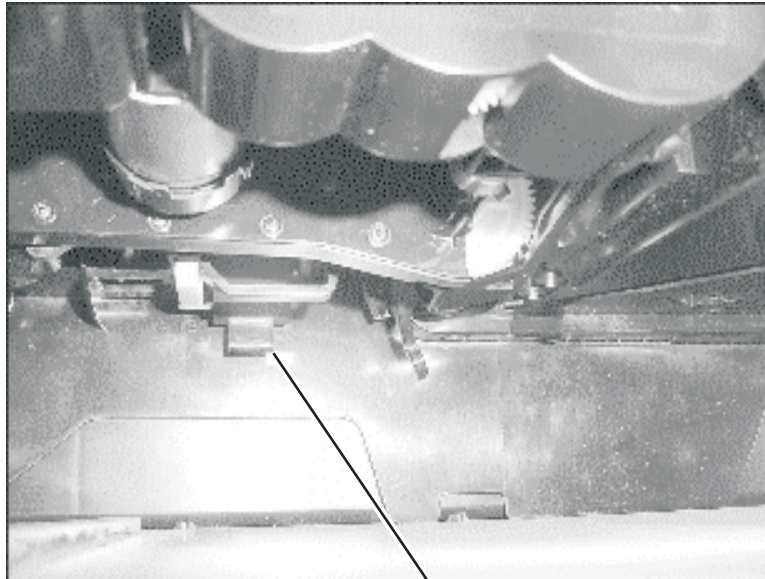

I

14. Disconnect the spring clip (J) from the pick arm. Be sure not to let the spring come off of the lower frame. Also identify which pegs the spring clip is sitting on. These pegs are typically marked with white paint.

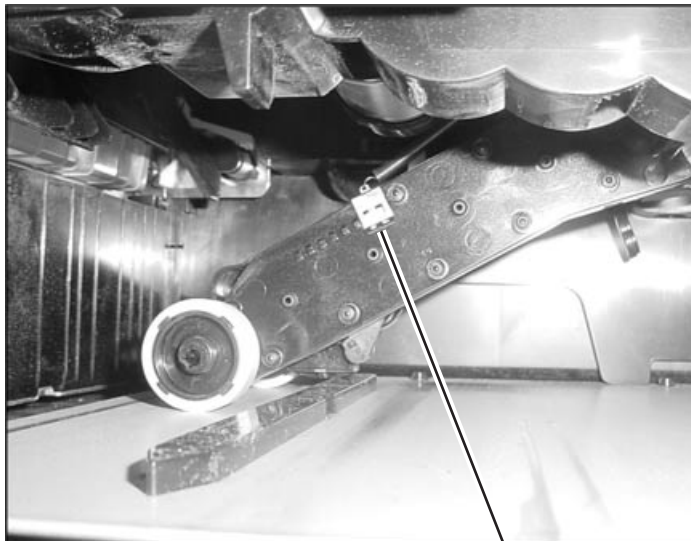

J

BOR drive assembly removal

See **“BOR housing assembly with motor”** on page 7-30 for the part number.

1. Open the front cover.
2. Remove the yellow toner cartridge.
3. Remove the front right light shield cover.
4. Remove the BOR housing assembly screw type **“323”** (A) and remove the assembly.

Note: Gear (B) can easily fall from the assembly. Be careful not to lose the gear.

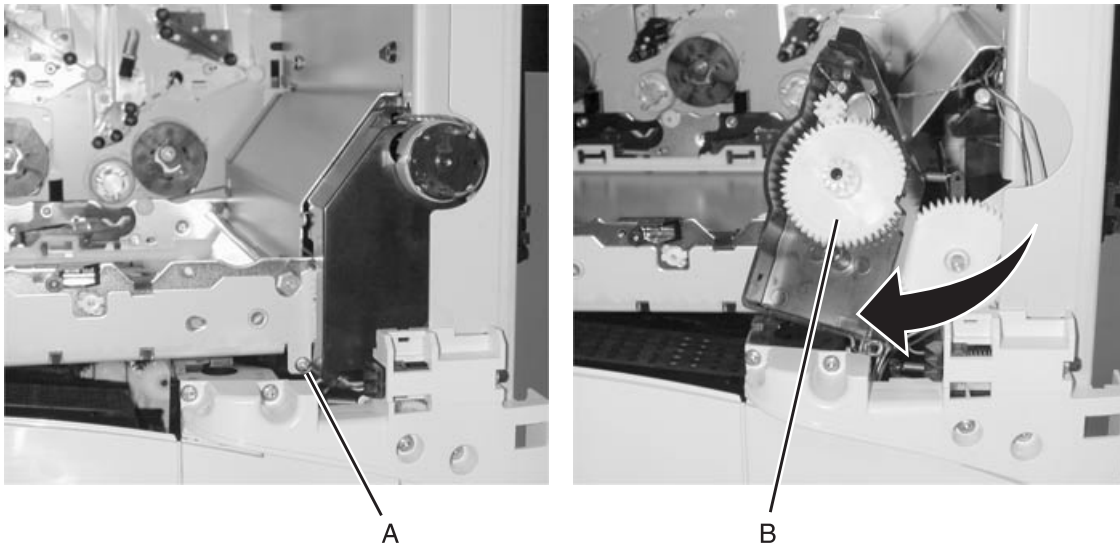

Cartridge contact assembly removal

See **“Cartridge contact assembly”** on page 7-31 for the part numbers.

Warning: Do not remove the printhead unless instructed to do so.

1. Open the front cover.
2. Remove the toner cartridges.
3. Remove the ITU assembly. See **“ITU assembly removal”** on page 4-37.
4. Set aside the top cover assembly. It is not necessary to totally remove it. See **“Top cover assembly removal”** on page 4-5.
5. Remove the developer HVPS. See **“Developer HVPS board removal”** on page 4-28.

It is not necessary to remove the entire assembly unless you are removing the black cartridge contact assembly. If you are removing the yellow, cyan, or magenta cartridge contact assemblies, remove only the large portion of the developer HVPS board.

6. Disconnect the signature button cable (A) from the developer HVPS board for the cartridge contact assembly you are removing.

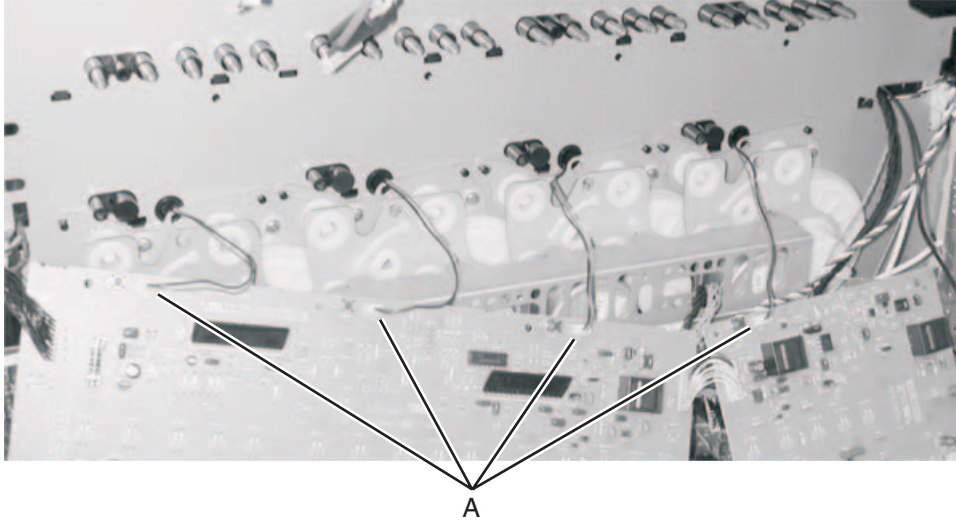

7. Remove the three mounting screws from the cartridge rail screws in the front (B) and one from the rear (C) and remove the rail of the selected cartridge assembly (yellow shown).

Warning: When removing the black, cyan, or magenta cartridge rails it is necessary to remove the appropriate printhead assembly. Before you can remove the cartridge rail screws, scribe the location of the printhead on the frame before removing the printhead. This will help put the printhead back in the previous location. If a printhead alignment problem develops, go to **“Printhead removal and adjustment” on page 4-50.**

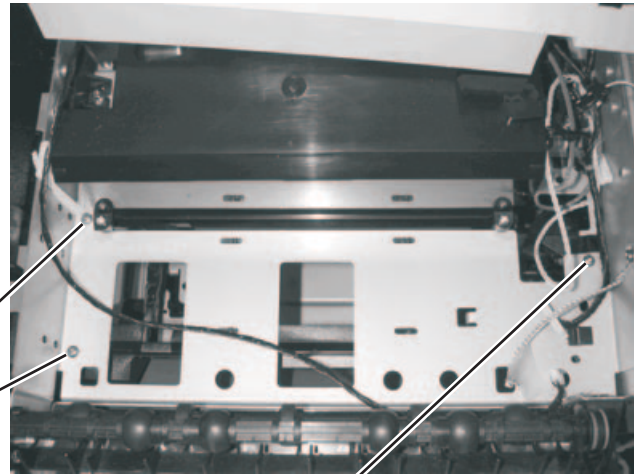

8. Remove the two upper screws (D) that mount each cartridge drive motor and the cartridge contact assembly to the upper frame for the cartridge contact assembly you want to remove.

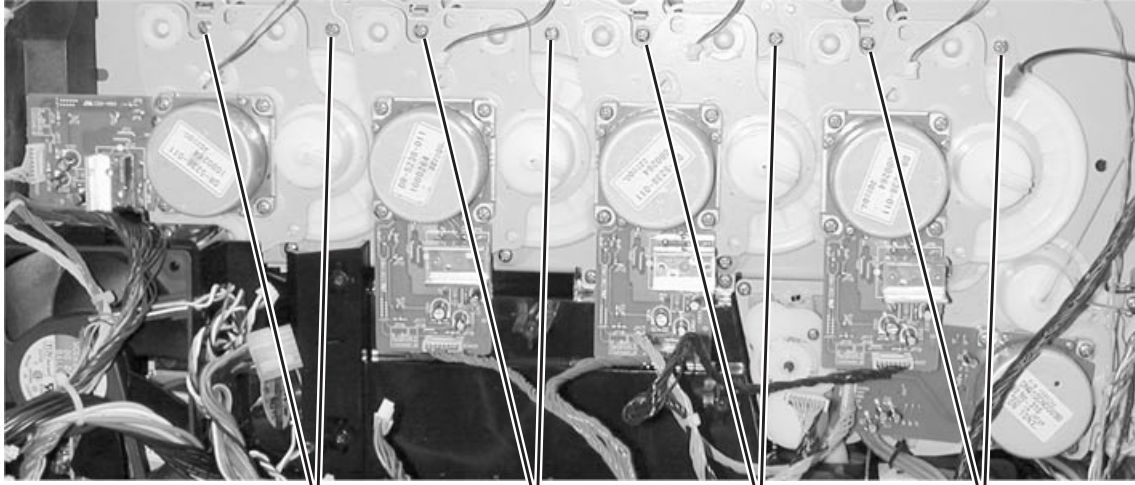

D (Yellow)

D (Cyan)

D (Magenta)

D (Black)

9. Press the three cartridge contact assembly retaining tabs (E) and remove the assembly.

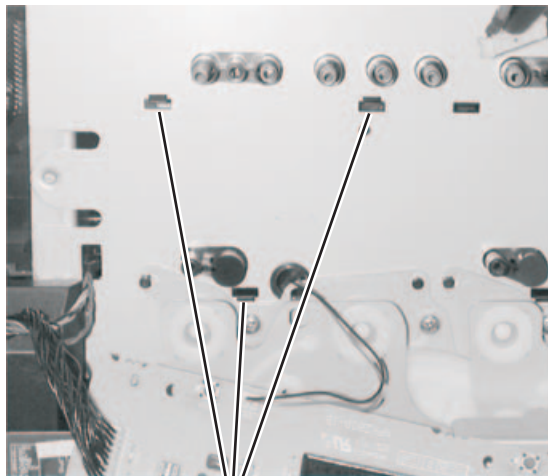

E

Cartridge drive assembly removal

See **“Cartridge drive assembly, cyan/magenta/black”** for the part number.

1. Remove the RIP board shield assembly. See **“RIP board shield assembly removal”** on page 4-71.
2. Remove the engine board. See **“Engine board removal”** on page 4-29.
3. Remove the three cartridge drive assembly mounting screws (A) for the cartridge drive assembly you want to remove.
4. Disconnect the cable (B) from the cartridge drive assembly.

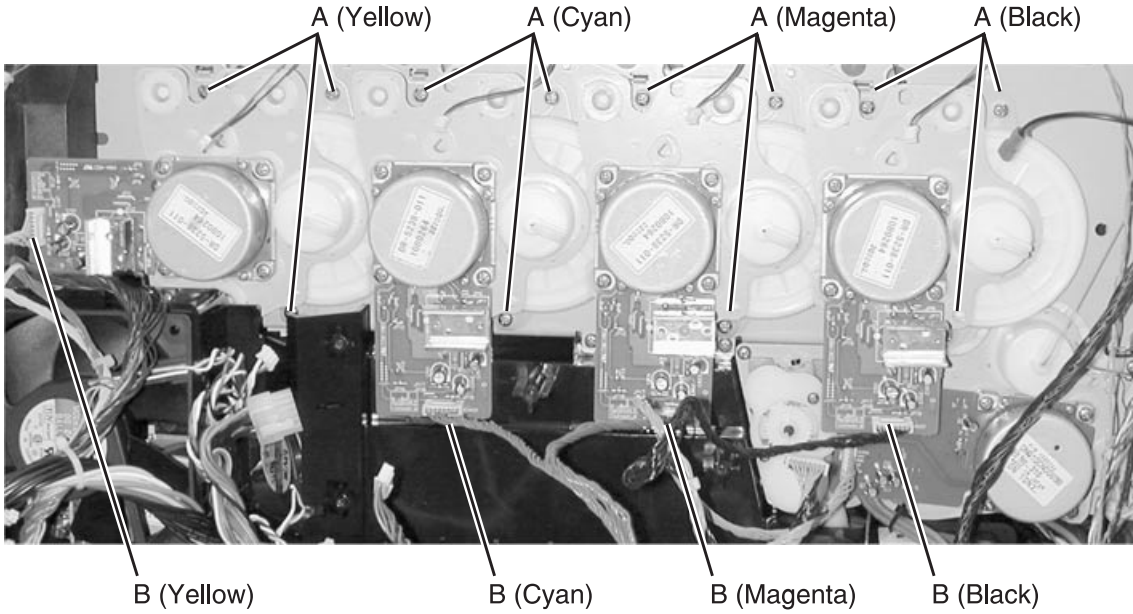

5. Remove the cartridge drive assembly.

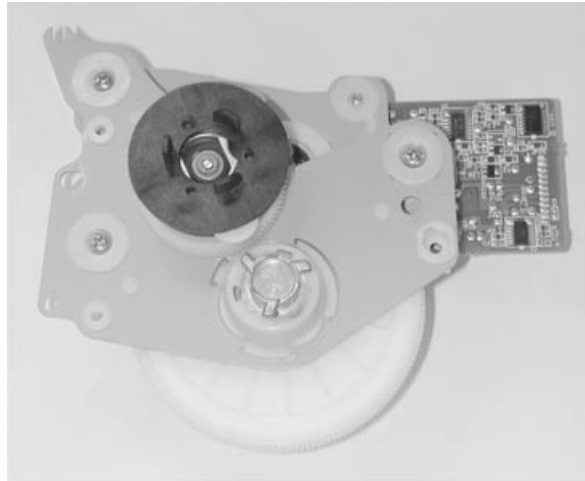

Cartridge rail assembly

1. Open the front cover.
2. Remove the toner cartridges.
3. Remove the ITU assembly. See **“ITU assembly removal” on page 4-37**.
4. Set aside the top cover assembly. It is not necessary to totally remove it. See **“Top cover assembly removal” on page 4-5**.
5. Remove the developer HVPS. See **“Developer HVPS board removal” on page 4-28**.
It is not necessary to remove the entire assembly unless you are removing the black cartridge rail. If you are removing the yellow, cyan, or magenta cartridge rails, remove only the large portion of the developer HVPS board.
6. Remove the three mounting screws in the cartridge rail in the front (A) and one from the rear (B) and remove the rail of the selected cartridge assembly (yellow shown).

Warning: When removing the black, cyan, or magenta cartridge rails it is necessary to remove the appropriate printhead assembly. Before you can remove the cartridge rail screws, scribe the location of the printhead on the frame before removing the printhead. This will help put the printhead back in the previous location. If a printhead alignment problem develops, go to **“Printhead removal and adjustment” on page 4-50**

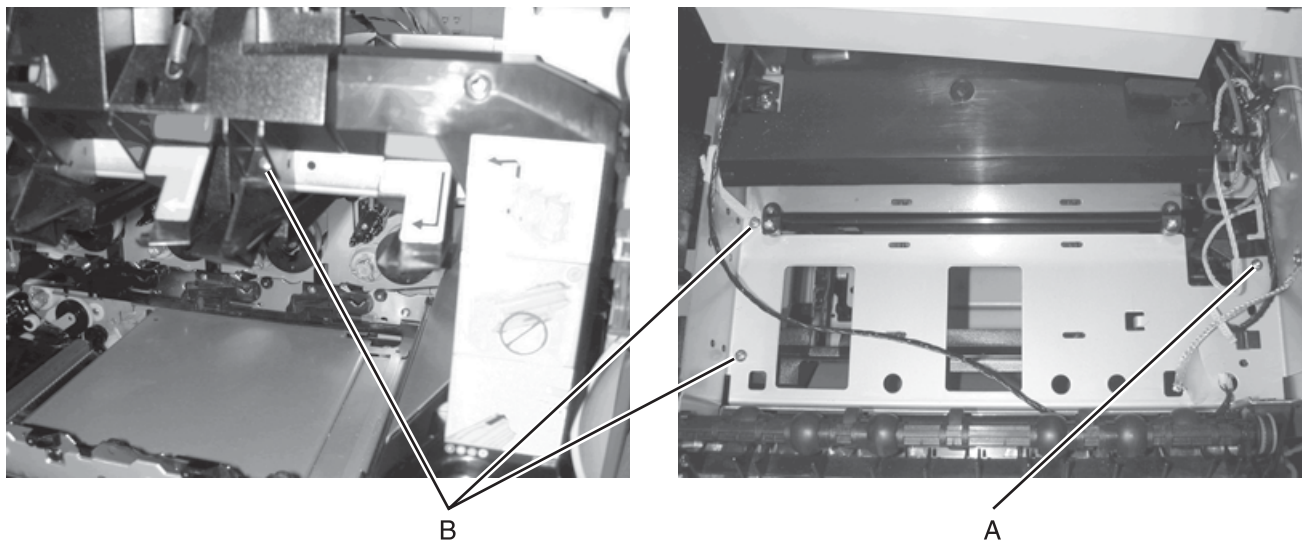

Developer HVPS board removal

See **“Developer HVPS board”** on page 7-38 for the part number.

1. Remove the RIP board shield assembly. See **“RIP board shield assembly removal”** on page 4-71.
2. Remove the four screws type **“323”** (A) and four screws type **“121”** (B) that mount the developer HVPS board.

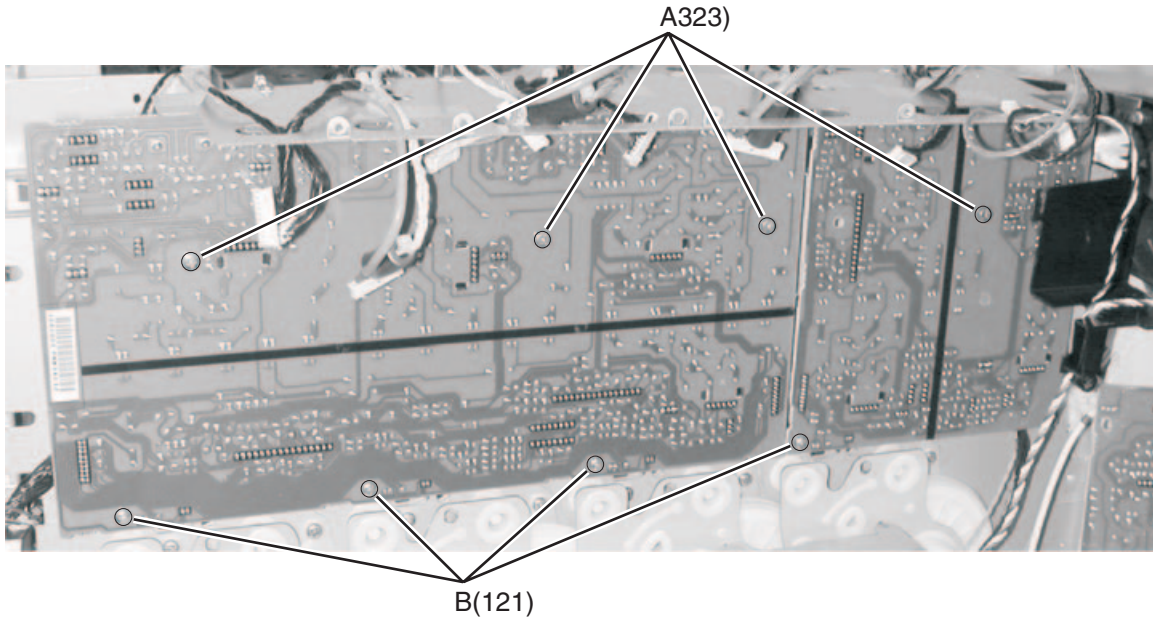

3. Disconnect the HVPS to RIP board cable (C), the cartridge signature button cables (D) and the doctor blade cable (E) from the developer HVPS board and remove the board.

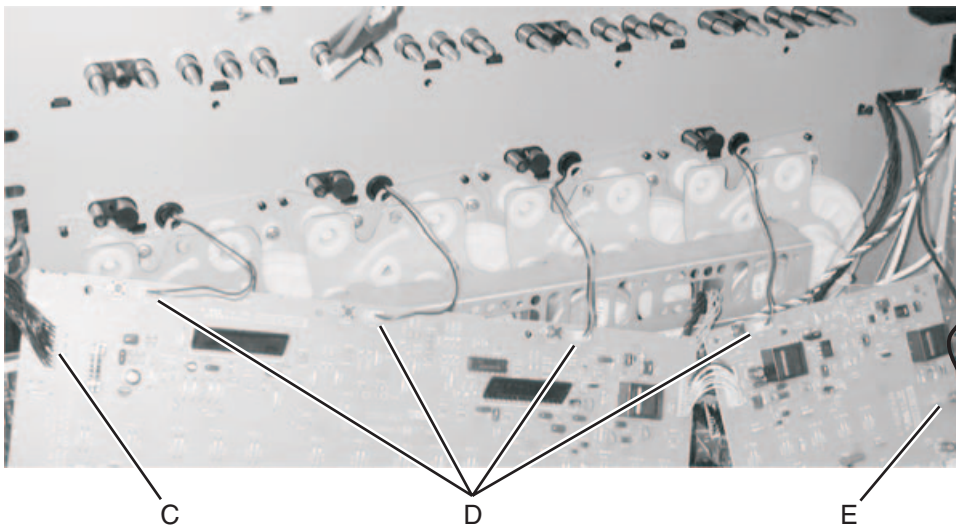

Installation note:

1. Disconnect the cable between boards.
2. Install the large board by attaching the bottom screws loosely, attach the top screws, then tighten the bottom screws.
3. Connect the boards
4. Install the small board in the same manner as the large board.

Engine board removal

See **“Engine board”** on page 7-39 for the part number.

1. Remove the rear fan cover. See **“Rear fan cover removal”** on page 4-8.
2. Remove the rear cover. See **“Rear cover removal”** on page 4-8.
3. Disconnect all cables from the engine board.
4. Remove the screw **“323”** (A) holding the grounding clip (B) and remove the clip.
5. Remove the engine board screw type **“323”** (C) and remove the engine board.
6. Remove the engine board. Be careful not to damage the paper size switches and actuators (D).

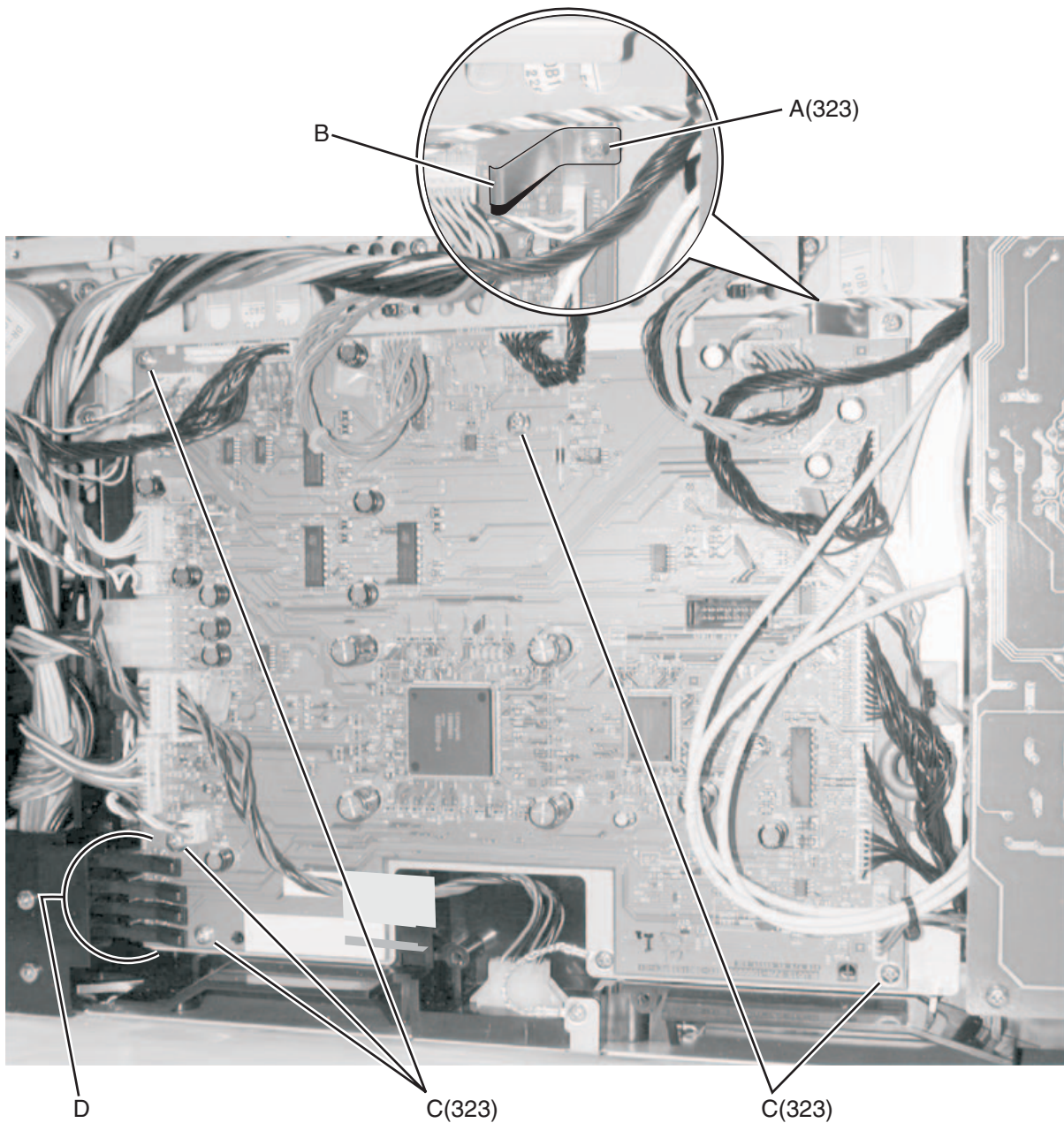

Engine board shield removal

See **“Engine board shield”** on page 7-39 for the part number.

1. Remove the RIP board shield assembly. See **“RIP board shield assembly removal”** on page 4-71.
2. Remove the engine board. See **“Engine board removal”** on page 4-29.
3. Remove the engine board shield screw type **“323”** (A), screw type **“232”** (B), and remove the shield.

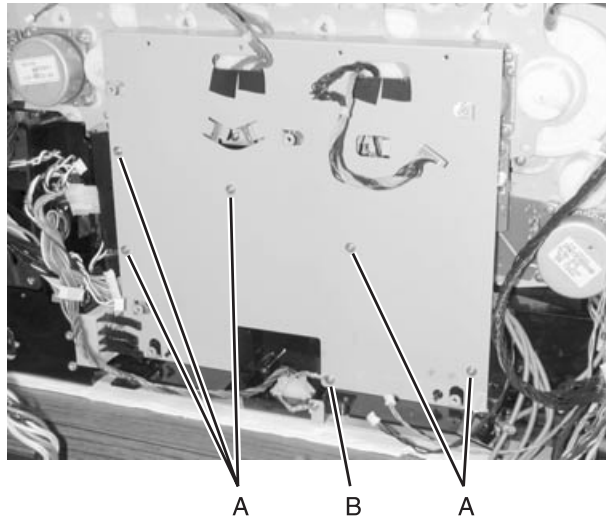

Friction buckler removal

See **“Friction buckler”** on page 7-21 for the part number.

1. Press the multipurpose feeder (MPF) latch to disconnect the MPF.
2. Use needlenose pliers to remove the buckler housing.

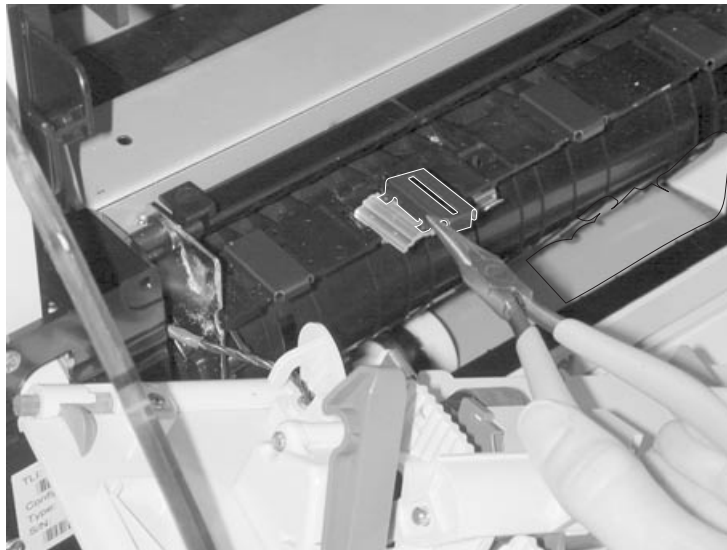

3. Replace the friction buckler.

Fuser assembly removal

CAUTION: Be sure the fuser assembly has cooled before you remove it.

See **“Fuser assembly 115V 500W” on page 7-9** or **“Fuser assembly 220V 500W” on page 7-9** for the part numbers.

1. Open the lower right door assembly.
2. Unlatch the two fuser latches (A).
3. Remove the fuser assembly.

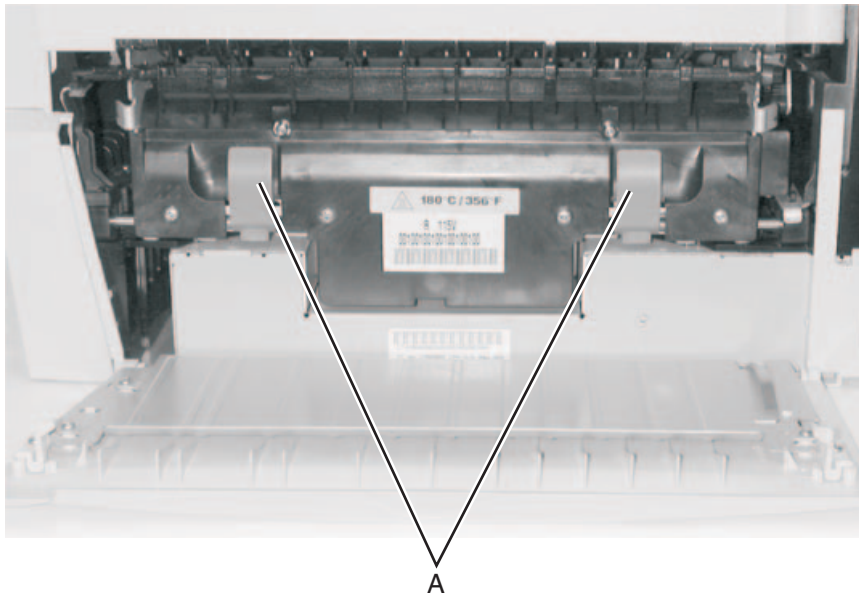

Fuser bottom duct removal

See **“Fuser bottom duct”** on page 7-5 for the part number.

1. Remove **“Fuser assembly removal”** on page 4-31.
2. Remove **“Fuser top duct removal”** on page 4-34.
3. Remove the redrive belt cover duct (A).
4. Remove fuser left duct (B).

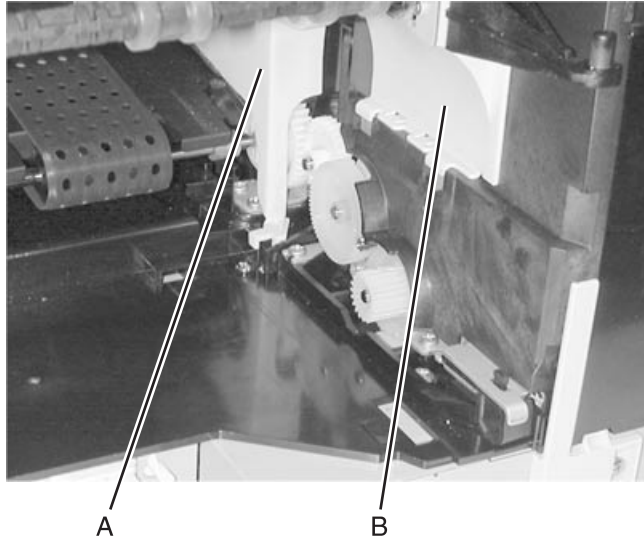

5. Remove fuser bottom duct.

Fuser drive assembly removal

See **“Fuser drive assembly w/motor”** on page 7-12 for the part number.

1. Remove **“Fuser bottom duct removal”** on page 4-32.
2. Swing lever (A) and disengage VTB shaft.
3. Remove the fuser drive assembly screws (A) type **“323”** on page 4-3 and remove the assembly.

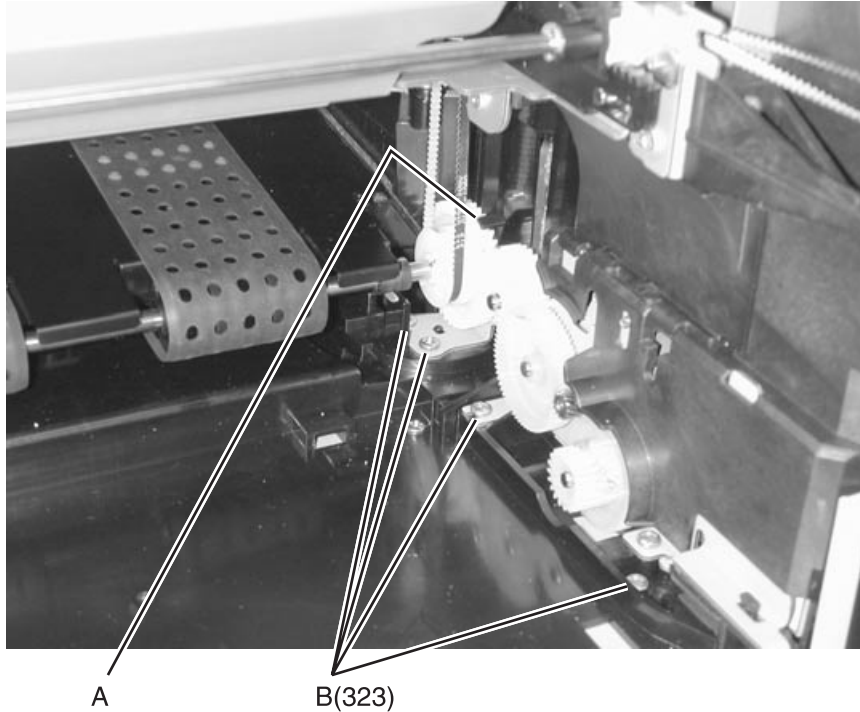

Fuser fan removal

See **“Fuser fan” on page 7-41** for the part number.

1. Remove the rear fan cover. See **“Rear fan cover removal” on page 4-8**.
2. Disconnect the fuser fan cable from connector J2 (B) on the engine board.
3. Remove the fuser fan screws (A), part number 12G6529 and remove the fan.

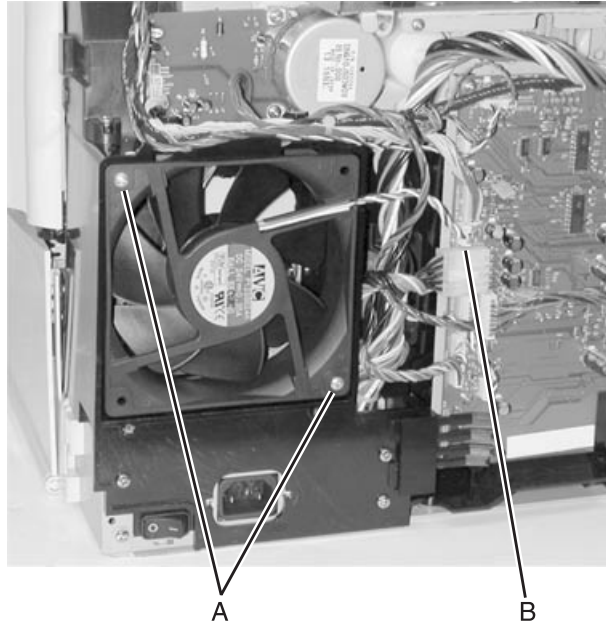

Fuser top duct removal

See **“Fuser top duct” on page 7-5** for the part number.

1. Remove the rear fan cover. See **“Rear fan cover removal” on page 4-8**.
2. Remove the fuser top duct screw type **“323” (A)** and remove the top duct.

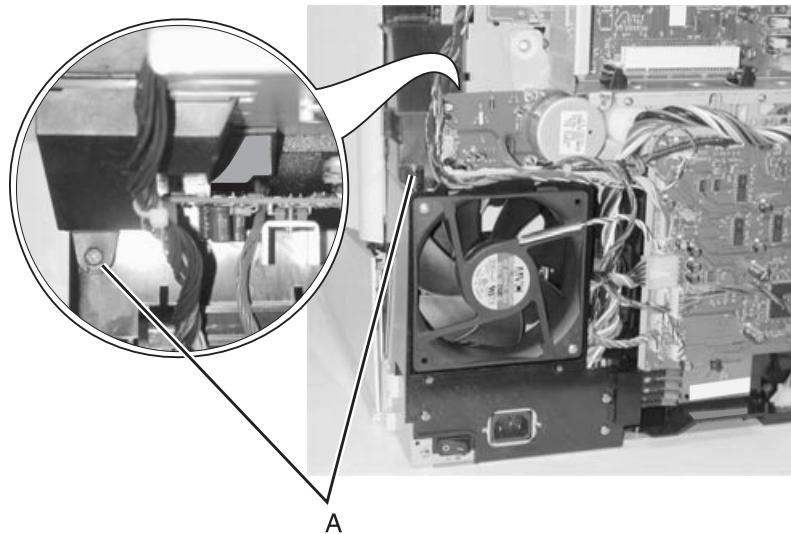

Fuser web oiler motor assembly removal

See **“Fuser assembly, web oiler 115V 500W”** on page 7-11 or **“Fuser assembly, web oiler 220V 500W”** on page 7-11 for the part number.

1. Remove the fuser top duct. See **“Fuser top duct removal”** on page 4-34.
2. Remove the paper path access door cover right mounting screw (A).

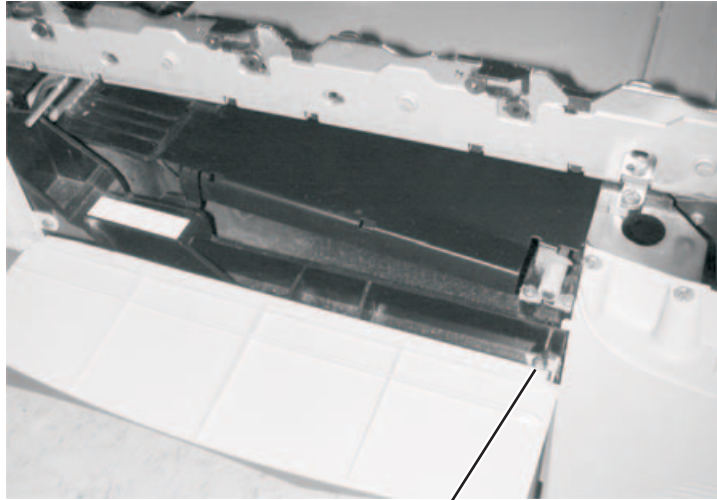

A

3. Remove the front right handle cover assembly. See **“Front right handle cover assembly removal”** on page 4-9.
4. Disconnect the web oiler motor assembly cable (A).

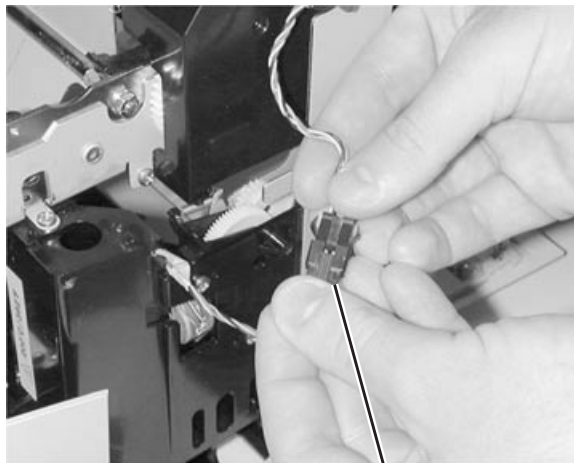

A

5. Remove the fuser web oiler motor assembly mounting screws and remove the assembly.

Installation notes

Note: When you reinstall the web oiler motor assembly, pull the excess cable, twist, install a cable tie, and route the cable down into the printer.

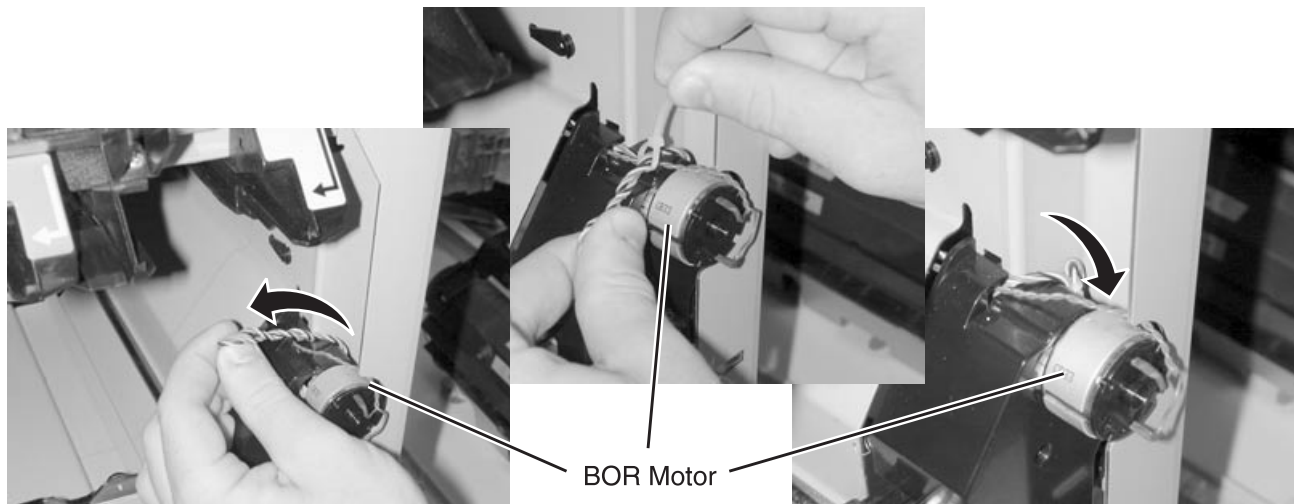

Note: Make sure the motor cable (A) is routed away from gears (B).

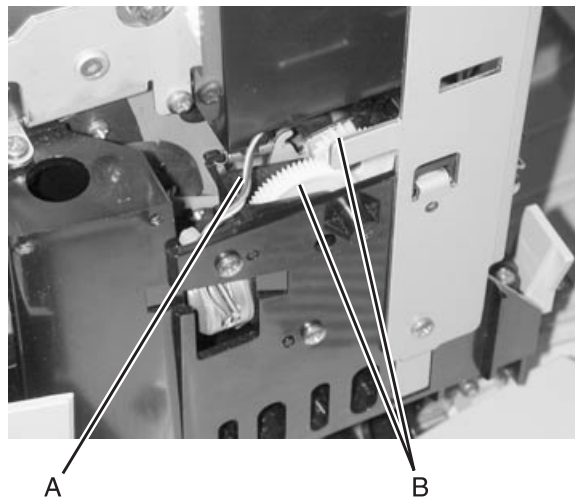

ITU assembly removal

See **“ITU assembly” on page 7-25** for the part number.

1. Open the front cover.
2. Remove the toner cartridges.
3. Open the MPF.
4. Raise the ITU release lever (A) and slide the ITU from the printer.

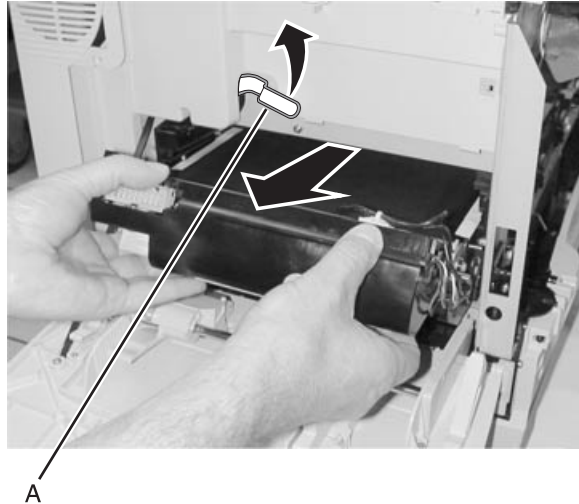

ITU drive assembly removal

See **“ITU motor drive assembly with SKC motor” on page 7-27** for the part number.

1. Remove the RIP board shield assembly. See **“RIP board shield assembly removal” on page 4-71**.
2. Remove the engine board shield. See **“Engine board shield removal” on page 4-30**.
3. Remove the ITU drive assembly mounting screws (A) and disconnect the cable.
4. Move the bottom of the ITU drive assembly toward you as you rotate the top of the assembly out of the printer. Be careful not to damage the large drive gear as you remove the ITU drive assembly.

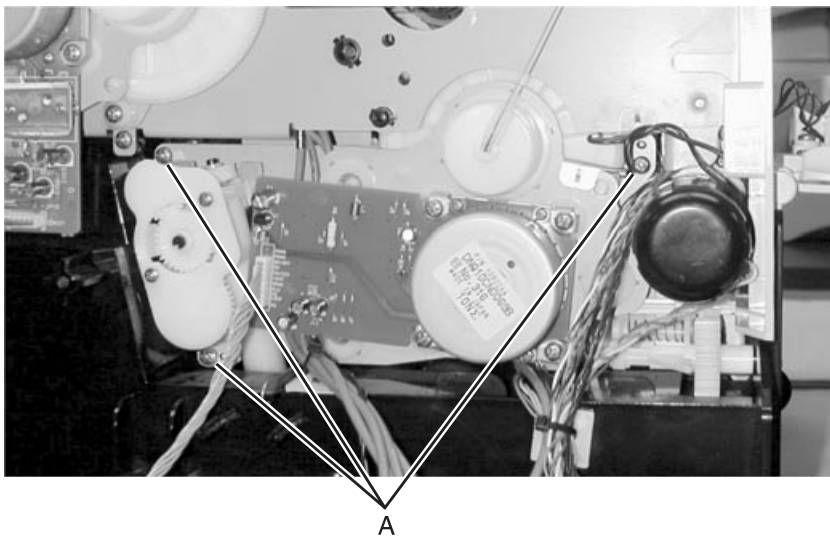

ITU drive motor removal

See **“ITU drive motor, SKC”** on page 7-27 for the part number.

1. Remove the RIP board shield assembly. See **“RIP board shield assembly removal”** on page 4-71.
2. Remove the engine board shield. See **“Engine board shield removal”** on page 4-30.
3. Remove the ITU drive motor mounting screws (B), disconnect cable (A), and remove the assembly.

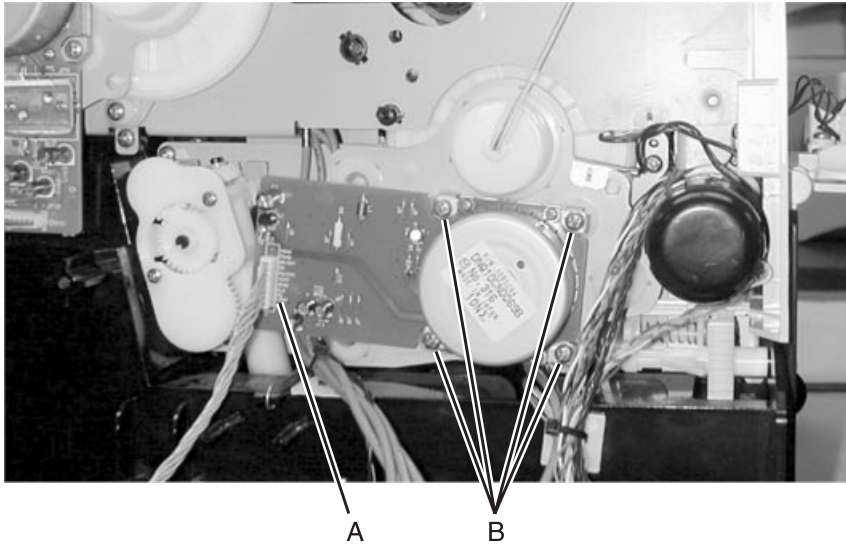

Low voltage power supply (LVPS) removal



See **“LVPS, 115V”** on page 7-35 or **“LVPS, 220V”** on page 7-35 for the part number.

1. Remove the rear fan cover. See **“Rear fan cover removal”** on page 4-8.
2. Remove the fuser top duct. See **“Fuser top duct removal”** on page 4-34.
3. Remove the LVPS screw type **“121”** (A) from the rear of the printer.

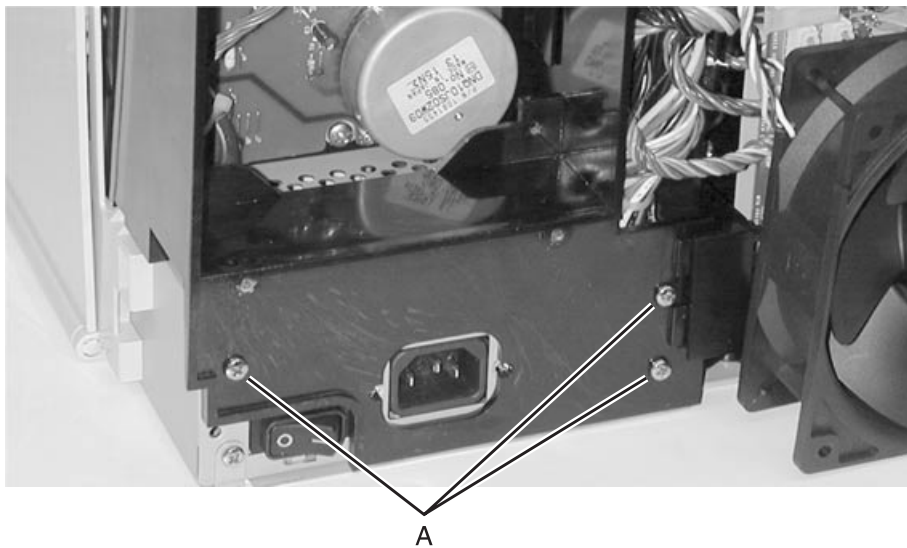

4. Remove the right rear cover screw type "121" (A).

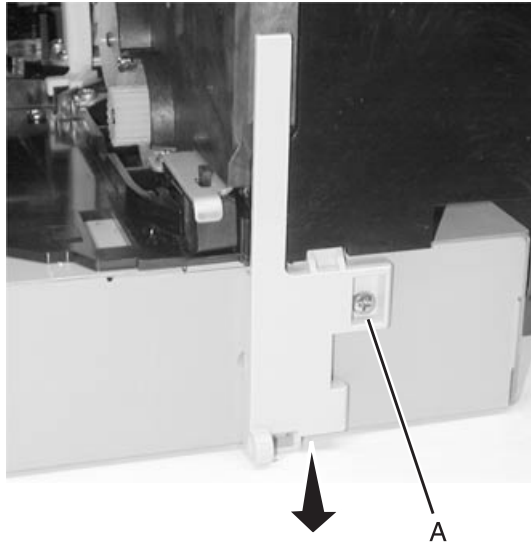

5. Open the redrive cover and remove the screw type "121" (A) from the top of the LVPS and remove the LVPS from the printer.

Note: Be sure to reinstall the ground strap when you replace the LVPS.

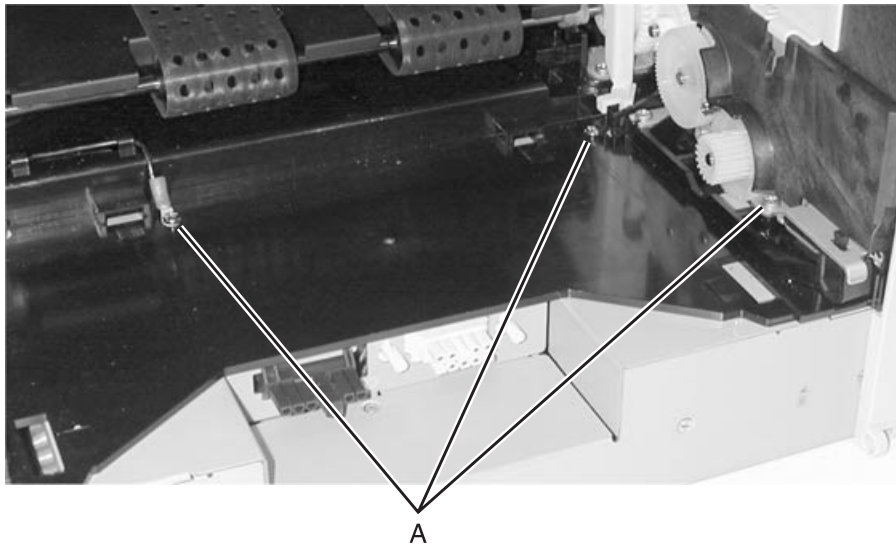

Multipurpose feeder (MPF) removal

See **“Multipurpose Feeder (MPF)”** on page 7-21 for the part number.

1. Open the MPF to the lowest position.
2. Remove the MPF cable cover screw (A).
3. Place flatblade screwdriver in the slot (B) on the MPF cable cover and gently pry open the cover.

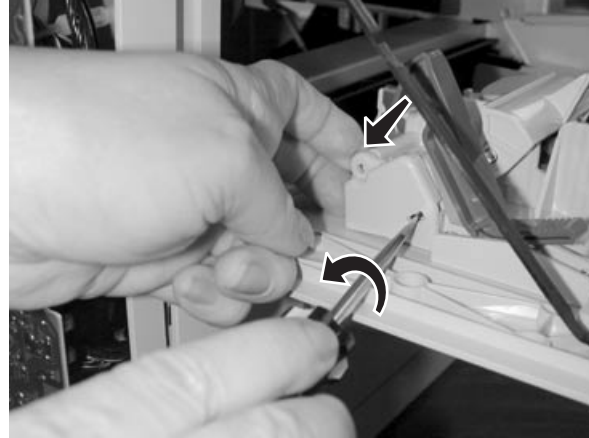
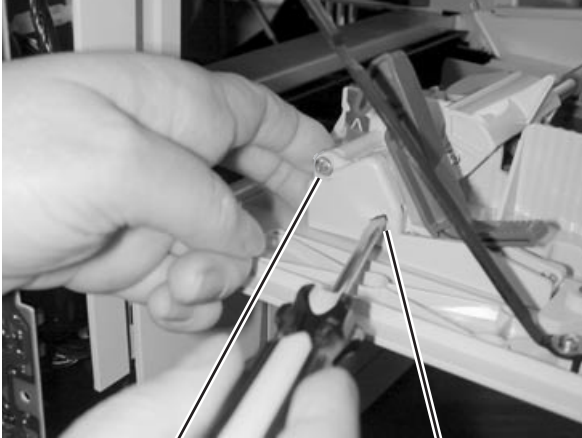

4. Disconnect the MPF switch cable from the MPF sensor (C).
5. Pull the MPF cable free of the enclosure and out from under the cable retainer (D).

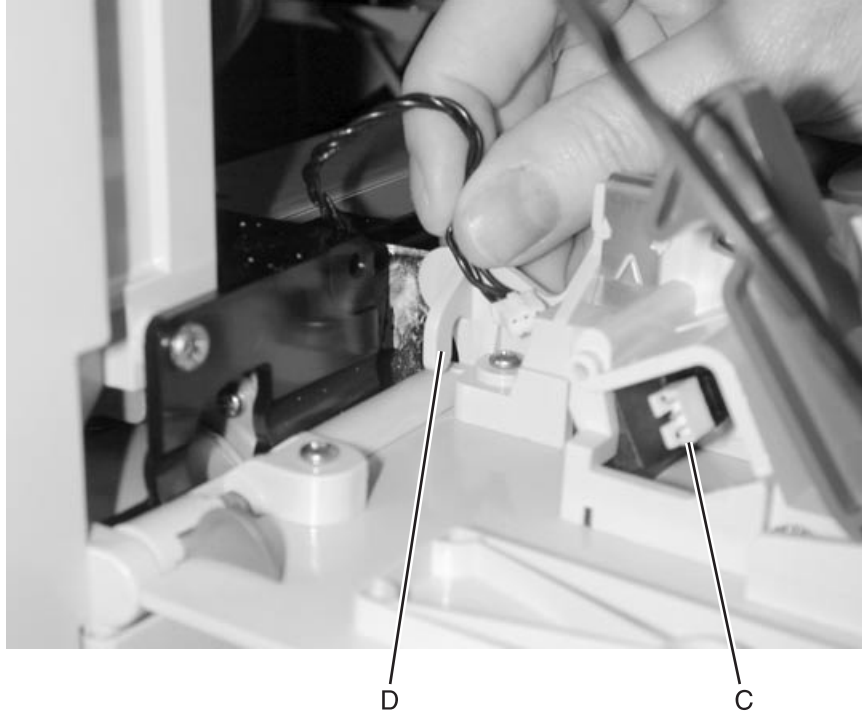

6. Remove the MPF strap screw (E) type **"412"** on page 4-4.



7. Release the MPF latch (F) and remove the MPF.

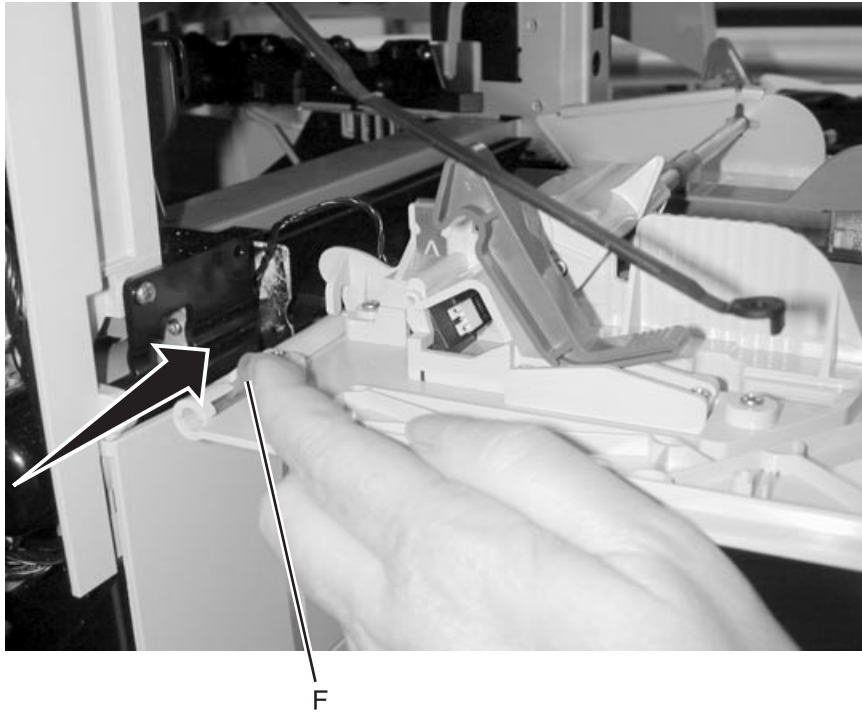

Nip relief handle removal

See **“Nip relief handle” on page 7-19** for the part number.

1. Remove lower left side covers to gain access to the nip relief handle.
2. Remove waste toner container.
3. Reinsert paper tray into printer.
If any fragments fall into the printer they should land in the paper tray and be easy to remove.
4. Remove the broken pieces of old nip relief handle.
 - a. Pull up the upper piece of handle to raise the nip relief link (A) and rotate the upper piece of handle 90° clockwise to free it from the link (A).

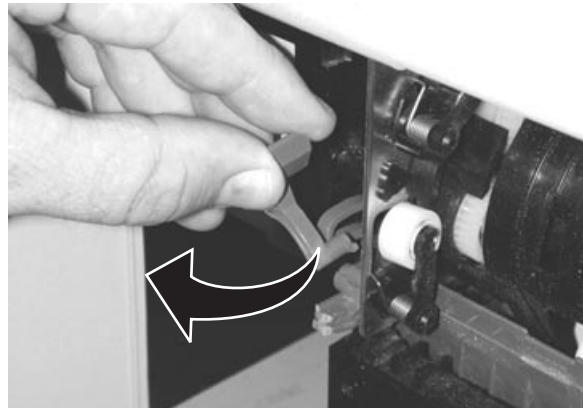
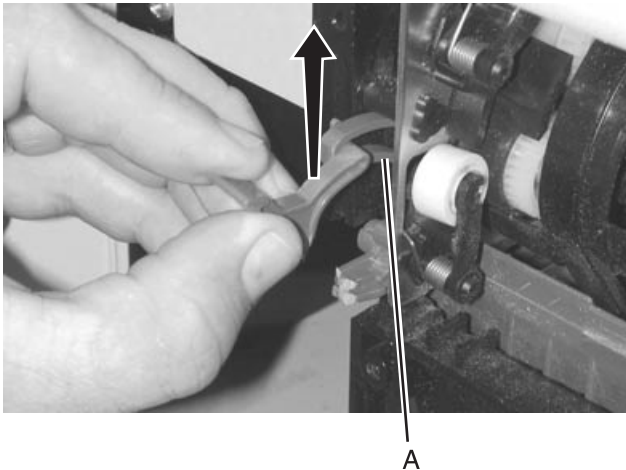

- b. Using a side cutter, cut the lower piece of the handle free from the post.

Some scarring of the post is expected, but be careful not to damage the post.

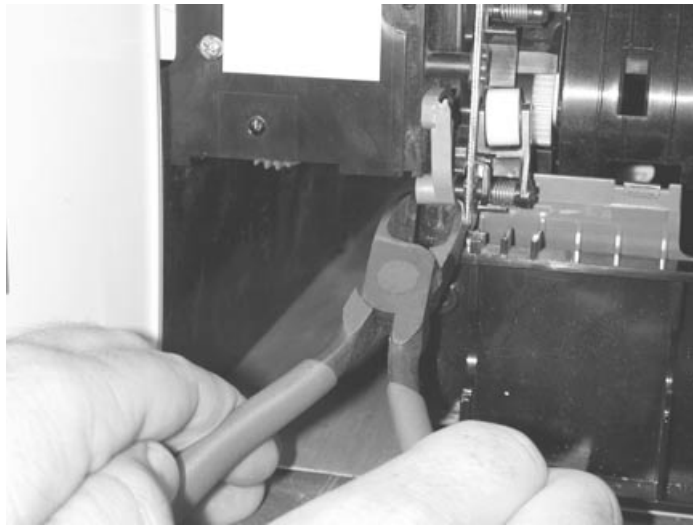

- C.** Remove any remnants of the handle.
Check the paper tray to check for debris. For example, see the fragment (B) in the following picture.

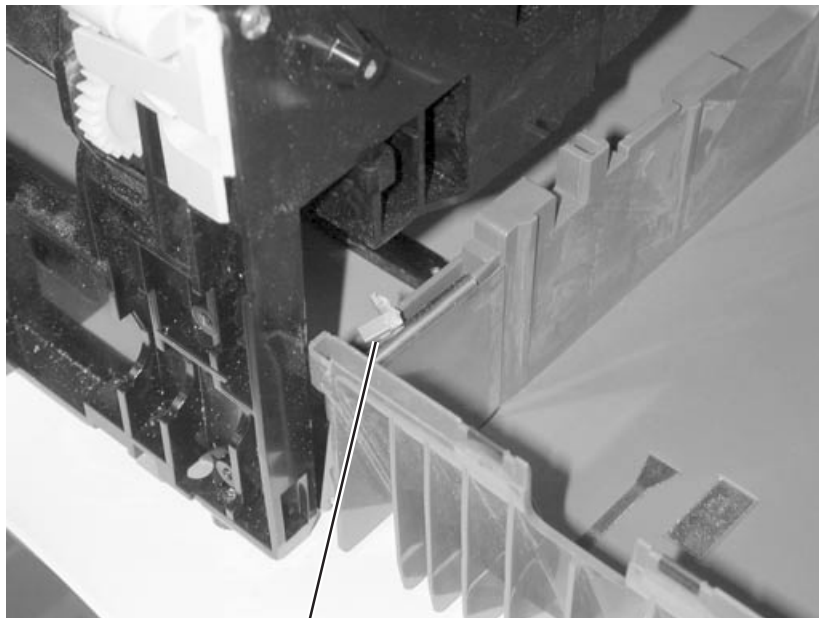

B

Installation notes:

1. Rotate the new nip relief handle into place to connect it to the nip relief link (A).

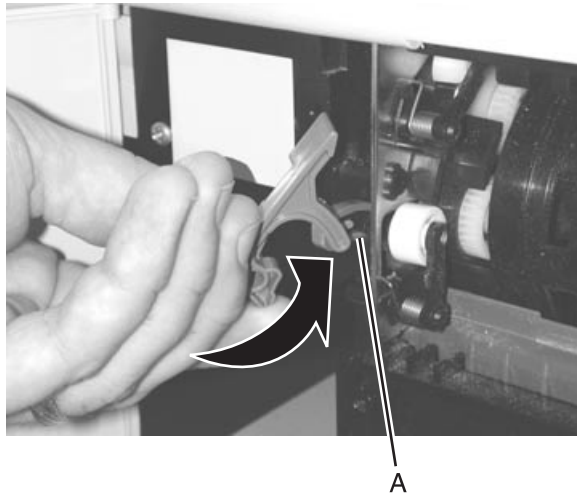

2. Using a screwdriver, gently pry the nip relief lever (B) towards the rear of the machine and insert lower portion of handle so that it is trapped between the lever and the reference edge plate (C).

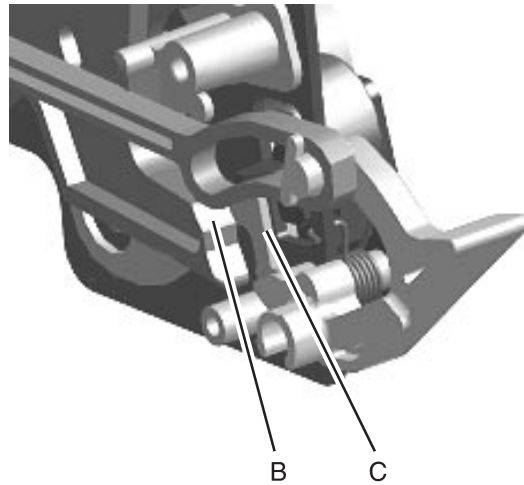
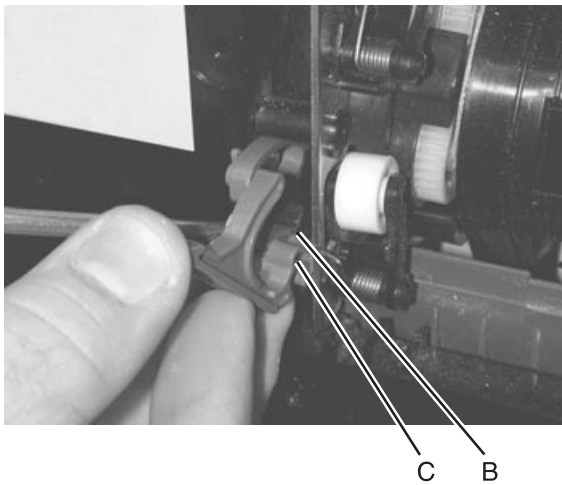

3. Holding the nip relief handle in place, use a flathead screwdriver to gently pry up on the top portion of the lever allowing the handle to press into place onto the post using moderate force.

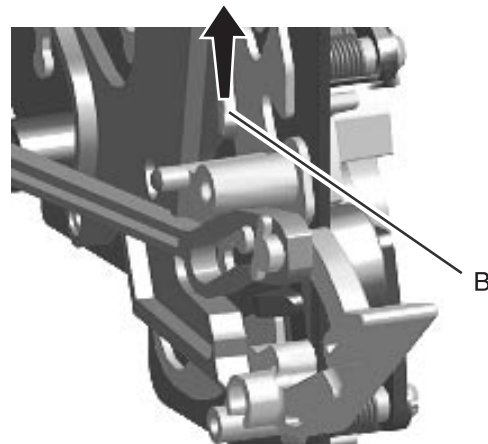
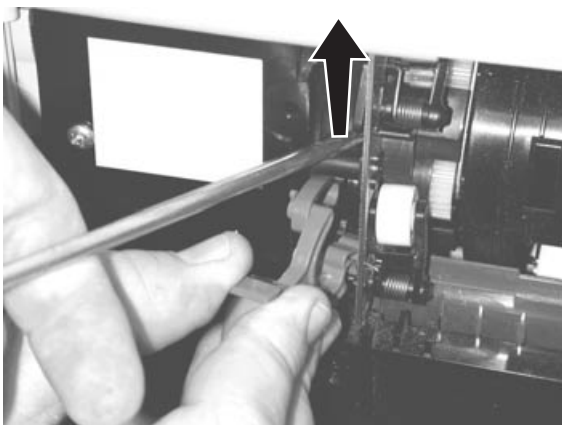

4. Once the handle snaps onto the post, press the upper portion of the handle to the right and rotate the handle into its home position.
This seats the nip relief lever into the correct position.

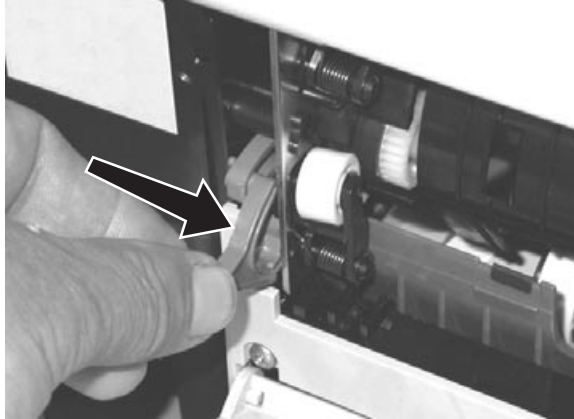

5. Check for proper operation.
6. Install the waste toner container.
7. Replace the covers.

Operator panel removal

See **“Operator panel assembly, low volt”** on page 7-3 or **“Operator panel assembly, high volt”** on page 7-3 for the part number.

1. Remove the operator panel bezel.



Bezel

2. Unlatch the operator panel latches (A).

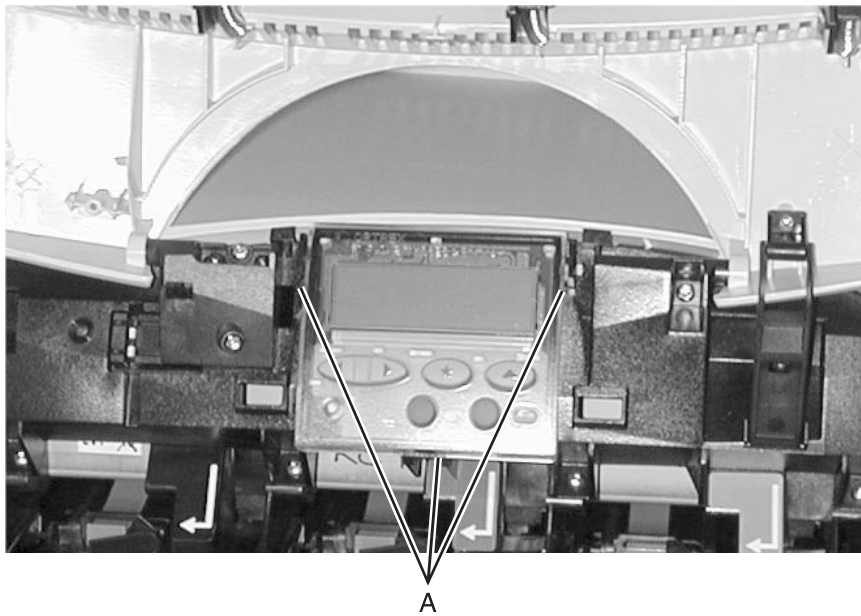

A

3. Disconnect the operator panel cable from the operator panel and remove the operator panel.

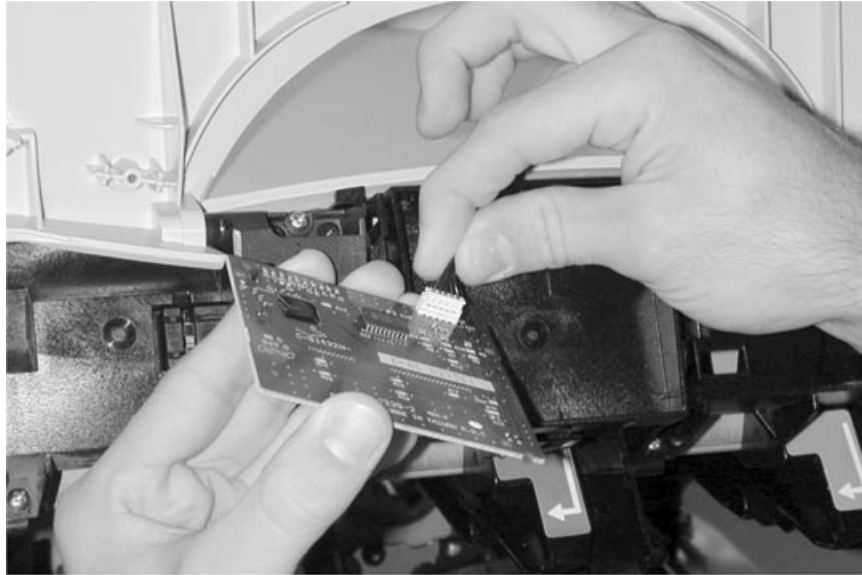

Outer EMC shield removal

Loosen screw type “232” (A) and lift the outer EMC shield from the printer.

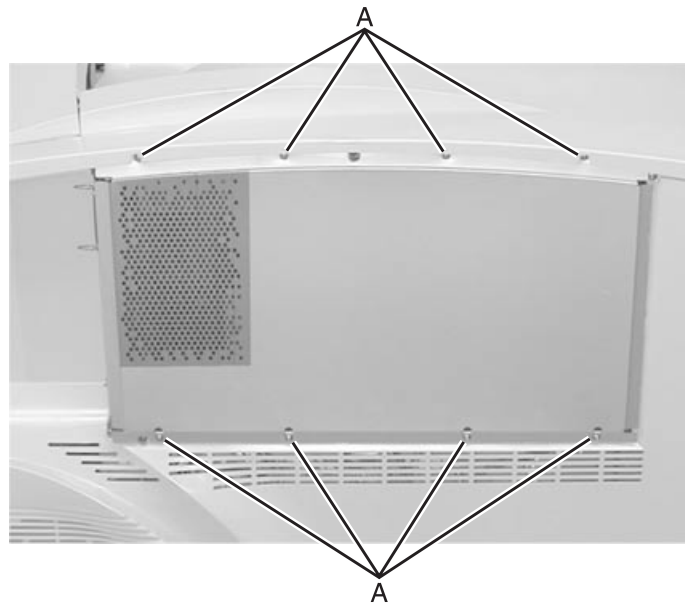

Paper size sensing assembly removal

See **“Paper size sensing assembly” on page 7-57** for the part number.

Note: The paper size sensing assembly contains components that easily fall apart as you remove the assembly. Be careful not to lose any of the components.

1. Remove the rear cover. See **“Rear cover removal” on page 4-8**.
2. Remove the rear fan cover. See **“Rear fan cover removal” on page 4-8**.
3. Remove the engine board shield. See **“Engine board shield removal” on page 4-30**.
4. Open the waste toner container door and slide the container out.
5. Remove the paper size sensor assembly screw type **“323” on page 4-3 (A)**.

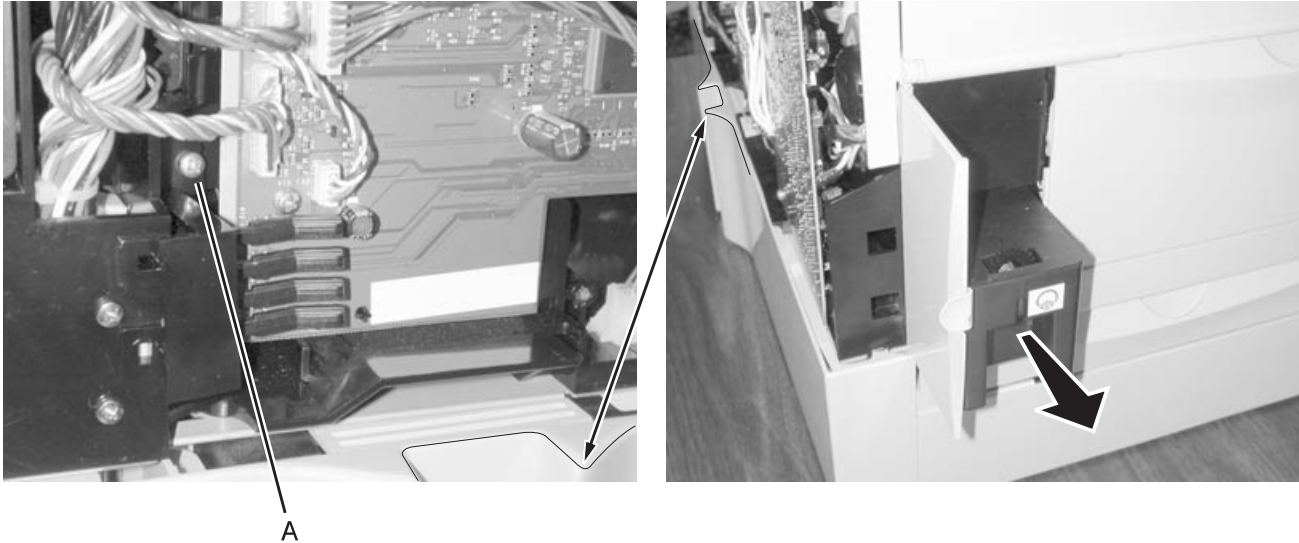

Pick rolls

See **“Pick rolls (2 each per package)” on page 7-24** for the part number.

Front roll

1. Wipe any toner or debris from the bottom pan to avoid contaminating the pick tires.
2. Pull the pick assembly down into the bottom pan and press the latch to remove the tire.



Note: Do not attempt to remove either the shaft or the clutch races.

Rear roll

Reach around and depress the latch (A) on the side of the shaft and remove the tire.

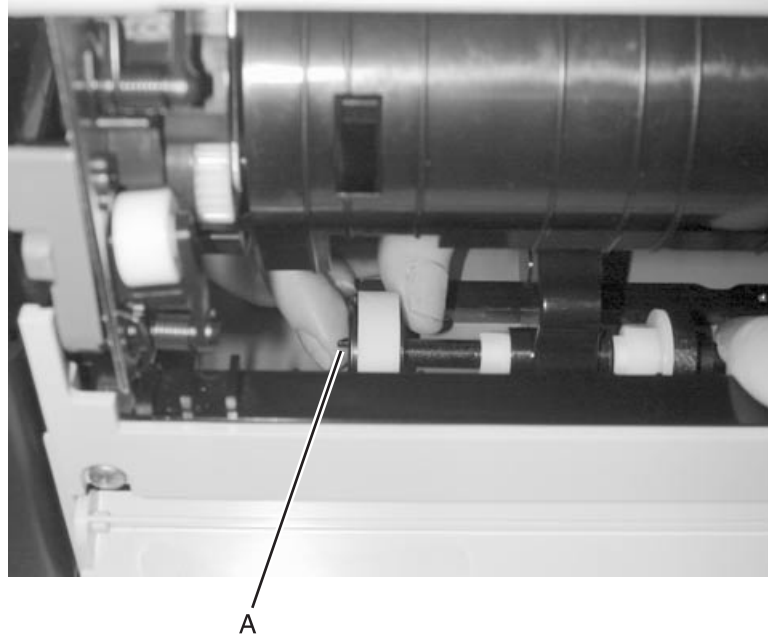

Installation notes:

- Replace both rollers at the same time.
- When you replace the front roller, make sure the roller is pressed against the shaft and the screw is fastened all the way down.
- When replacing both the front and back rollers, note the directional markings on the rollers and make sure the same narrow hub caps are facing each other. Check to see if the rollers turn freely.
- The autocompensator pick rolls are located in the base machine. There are also rollers in all tray options. If you have additional trays beneath your printer, check the condition of these rollers when you replace the rollers in your printer.

Printhead removal and adjustment

See “Printhead assembly” on [page 15](#) for the part numbers.

	Black (K)	Magenta (M)	Cyan (C)	Yellow (Y)
Printhead error codes	109	107	106	108
	114	116	115	117
	169	173	171	175
	170	174	172	176

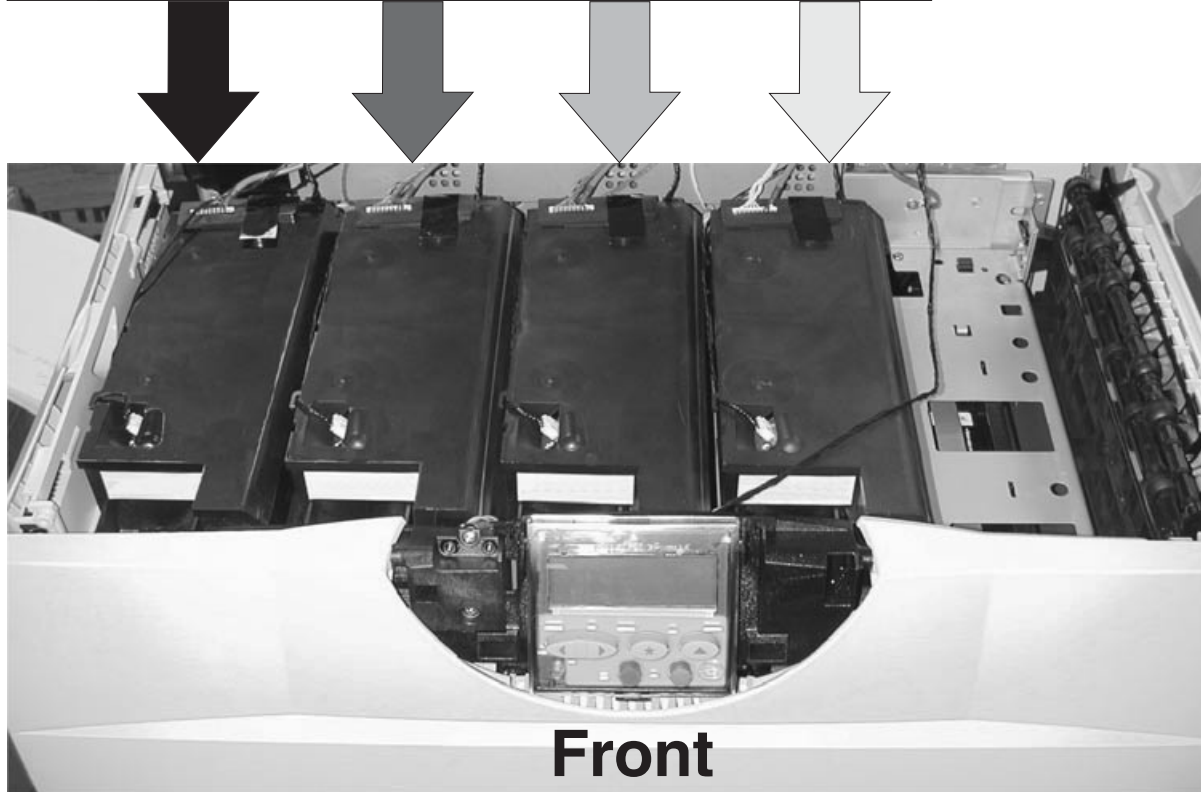

Warnings:

- Do not loosen or replace more than one printhead at a time to retain factory settings.
- Whenever a printhead is replaced, you must to perform the **“Printhead mechanical alignment”** on [page 4-51](#) and **“Electronic color alignment”** on [page 4-58](#).
- The front cover must be installed and closed before any printhead alignment can be performed. It is not necessary to remove the front cover to access the printheads.
- If there is a protective lens cover on the new printhead, it must be removed before installing the replacement printhead.

Printhead mechanical alignment

1. Identify the configuration of your printer. The following steps are similar for both versions, except you need to remove two extra screws when you have the PSD bracket.
You may have a PSD bracket (A), whether or not the PSD or thermistor is connected.

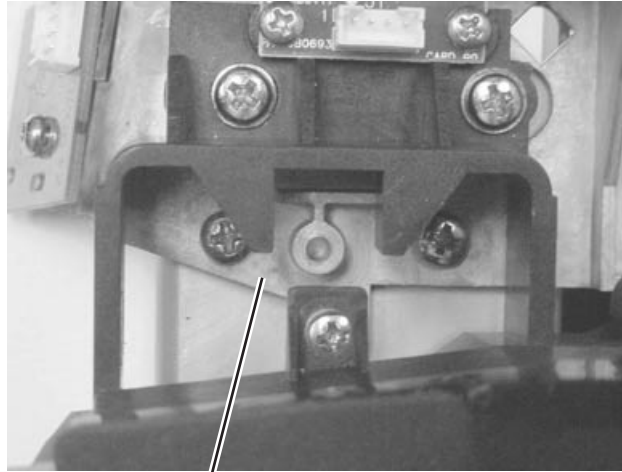

A

You may not have a bracket.

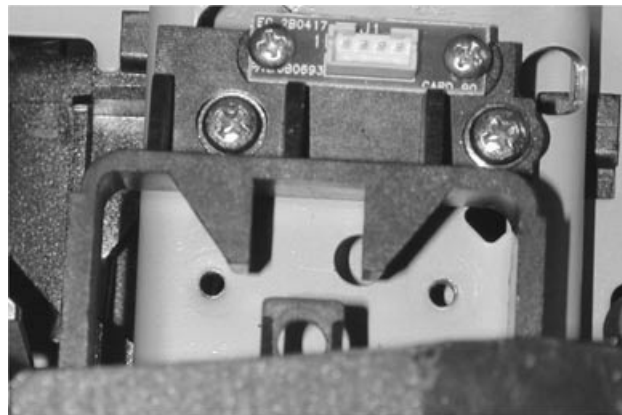

2. Insert the first printhead alignment tool.
 - a. If you have a PSD bracket, remove the two screws (A and B).
Note: Use a small diameter Phillips screwdriver to remove screw (A).

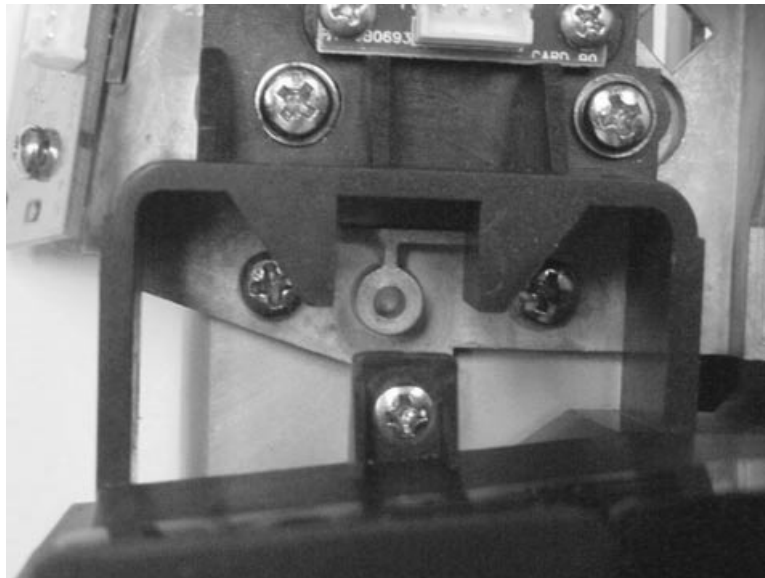

- b. Insert the printhead alignment tool, placing the locating pin (C) in the middle hole (A).
 - c. Secure the alignment tool bracket (D) with screw provided or a screw removed from the previous step.

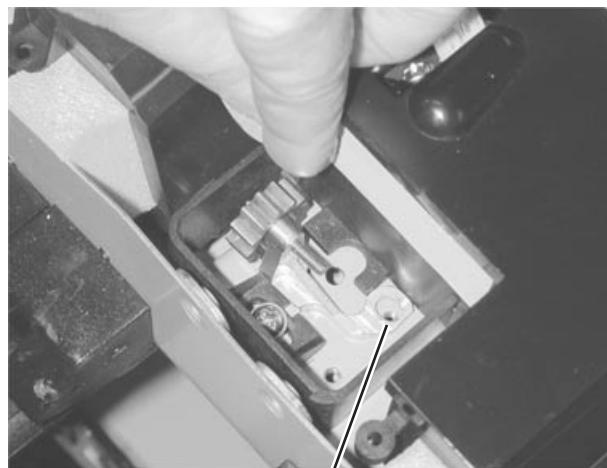
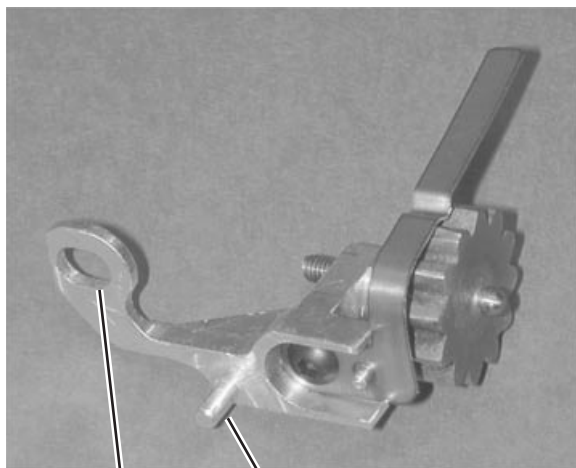

3. Install the second printhead alignment tool in the front of the printhead and secure alignment tool bracket (D) with screw provided.
Align the locating pin (C) in the hole in printer frame.

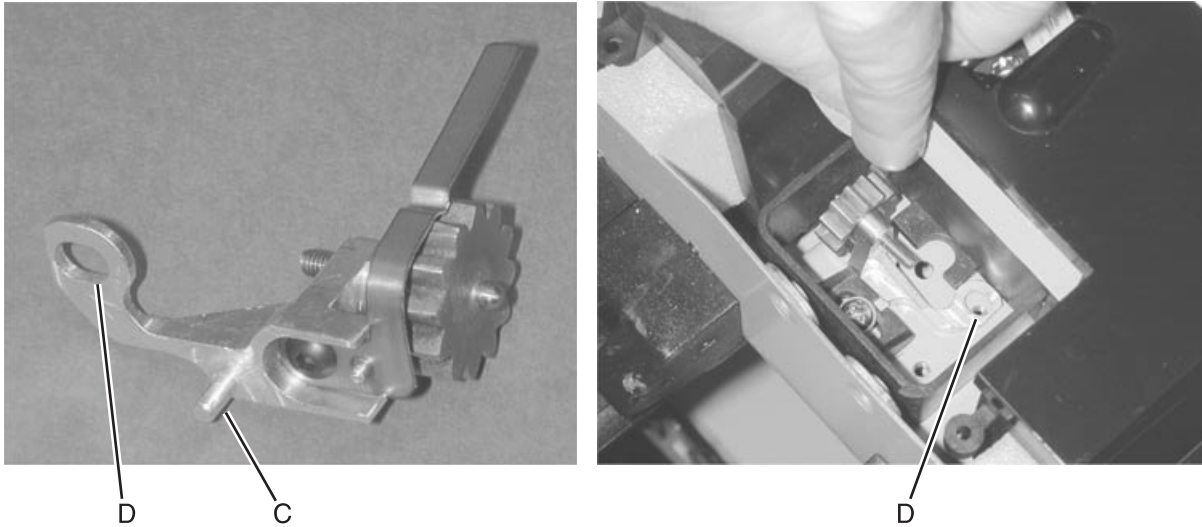

4. Turn the thumbwheel (E) until the end of the thumbwheel just touches the printhead mounting arm for both the front and rear alignment assemblies.

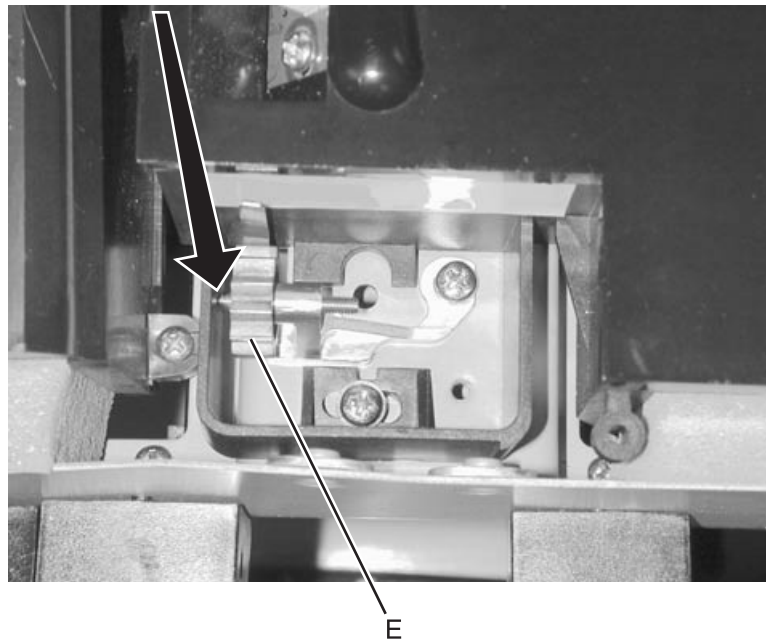

5. Remove the old printhead and install a new printhead assembly. Do not tighten the printhead screws yet.
Note: Make sure the right rear screw goes through the printhead spacer located at the right rear of the printer frame.

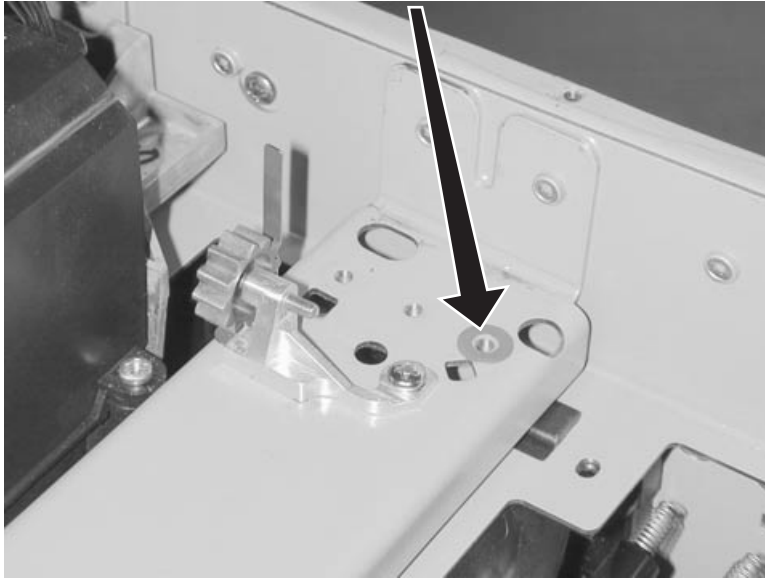

6. Bias the new printhead assembly against the front and rear stops.
7. Tighten the right rear printhead mounting screw. Then, tighten the front screw followed by the left rear screw. Make sure the printhead is biased against both the thumbwheels when tightening the screws.

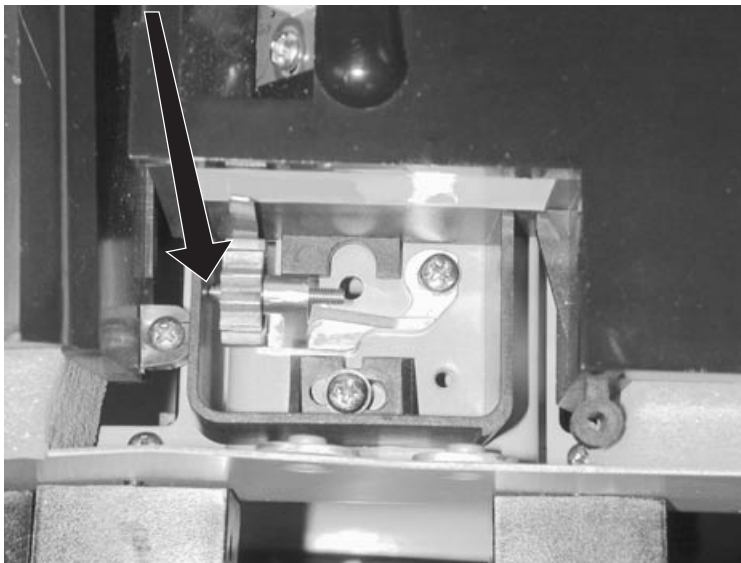

8. Securely close the front cover or reattach if previously removed.
9. If replacing the black printhead, go to step 12. Otherwise, enter Diagnostics Mode:
 - a. Turn the printer off.
 - b. Press and hold **Go** and **Return**.
 - c. Turn the printer on.
 - d. Release the buttons when *Performing Self Test* displays.
10. Select **Alignment Menu**, select the color of the printhead that was replaced, and set the Z value to zero. Exit the Diagnostics Menu
11. With the printer at *Ready* prompt, hook up a computer through the USB, network, or parallel connection and send the file, PHALIGN6.FLS, from the enclosed CD to the printer.

Note: Lay the printed Printhead Mechanical Alignment Test Page across the printheads in this orientation as a reference. Use the magnifier lens included in the FRU to view the scales at the ends of the color lines.

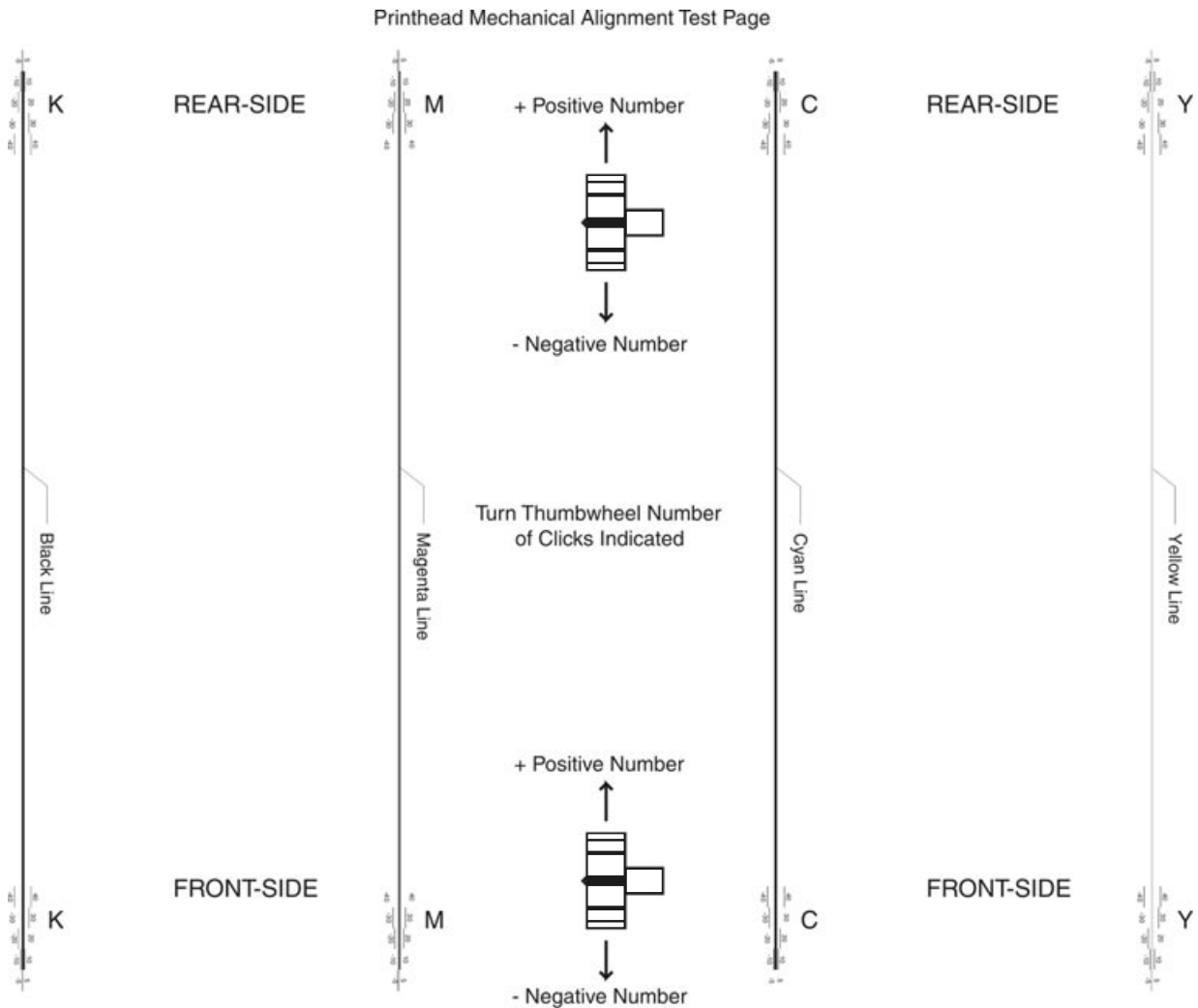

12. Loosen the printhead screws before making any adjustments to the thumbwheel.
13. Turn each thumbwheel the appropriate number of *clicks* as indicated by the test page.

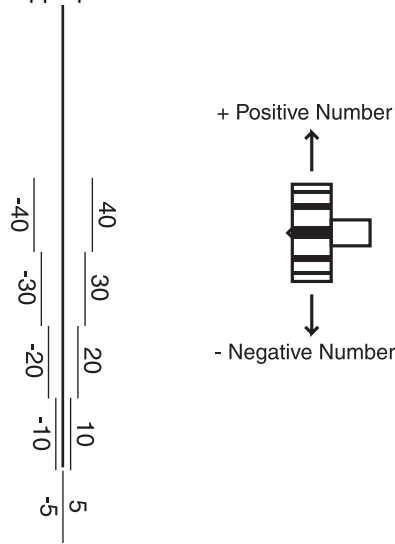

For example, if the test page indicates a +10 as the misalignment, turn the thumbwheel 10 *clicks* in the positive direction indicated on the test page. Do this for both the front and rear.

- Bias the printhead against both thumbwheels, and hold in place when tightening the printhead mounting screws.
 - Tighten the right rear printhead mounting screw. Then tighten the front screw followed by the left rear screw.
14. Send the file PHALIGN6.FLS (Printhead Mechanical Alignment Test Page) from the CD to the printer to verify printhead alignment.
 15. If the printhead alignment is within ± 5 for both front and rear positions, then proceed to electronic adjustment procedure. If not, repeat steps 12 through 15, until alignment is within ± 5 .
If you are replacing the black printhead, make sure on the test page that black is within ± 5 and also within ± 1 between the front and rear side. For example, if the rear looks like it is at +3, then the front should be between +2 and +4.

Note: When replacing the black printhead there is no Z value to reset. After the black printhead is mechanically aligned to the magenta printhead, it will be necessary to electronically align the three color printheads to the new black printhead.

Printer registration (only for black printhead replacement)

To perform the registration and alignment through the Diagnostics Menu:

1. Enter Diagnostics Mode.
 - a. Turn the printer off.
 - b. Press and hold **Go** and **Return**.
 - c. Turn the printer on.
 - d. Release the buttons when Performing Self Test displays.
2. Select **Registration** from the menu.
Four margin offset settings are displayed.

T= sxx	B=sxx
L= sxx	R=sxx

Where xx is the current value and s is the sign (+ or -)

3. Press **Go** to print the Quick Test Page.

Examine the registration marks on the top, bottom, left, and right sides on the page.

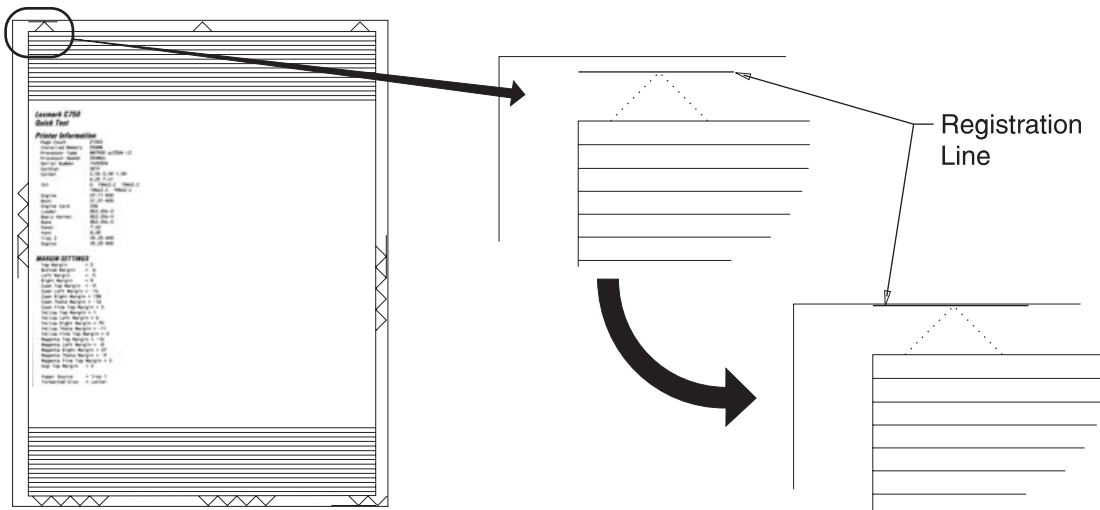

4. Adjust the margin settings so that the Registration lines are on the edge of the page. Repeat for each margin.
 - Adjust the top margin before bottom margin, and the right margin before the left.

Value	Description	Value change effect:	Range
T	Top margin	Increasing the value moves the color plane down the page	-25 to +25
L	Left margin	Increasing the value moves the color plane to the left	-25 to +25
R	Right margin	Increasing the value moves the color plane to the left	-12 to +12
B	Bottom margin	Increasing the value moves the color plane down the page	-12 to +12

- **Menu** changes the values.
 - **Select** saves the new value chosen and moves to the next margin setting.
 - Press **Go** to print the Quick Test Page after adjusting the margins and saving the change (**Select**).
5. After completing the registration, press **Return** to exit the registration function.

Electronic color alignment

Note: Use of a loupe or magnifying glass (4x or higher) may make observation of the alignment targets easier.

1. Press **Menu** until **Alignment** displays and press **Select**.
2. Select **Alignment Test** from the Alignment menu.
 Three sheets print for cyan, magenta, and yellow. Each is compared to black alignment.
 For example, one of the sheets shows cyan printed over a black target. Align the cyan over the black.
 Repeat for each of the colors cyan, magenta, and yellow.

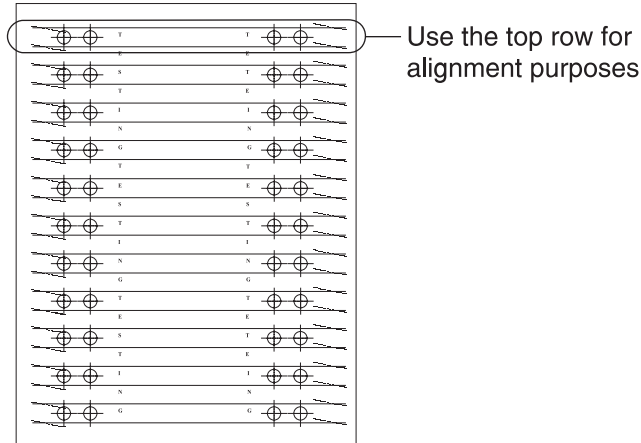

Examples of the alignment pages are available in Appendix B. See **“Printhead alignment test pages—magenta (one of three)” on appendix page B-9.**

3. To align cyan, press **Menu** until **Cyan** is displayed, press **Select**. Four alignment settings are displayed.

T= Top	L= Left
R= Right	Z= Theta

- **Menu** changes the values.
- **Select** saves the new value chosen and moves to the next margin setting.
- Press **Go** to print the individual color Alignment Page after adjusting the targets and saving the change (**Select**).
- The range of values differs for the various margin offsets.

Value	Description	Range
T	Top Margin Offset	-128 to +127
L	Left Margin Offset	-300 to +300
R	Right Margin Offset	-300 to +300
Z	Theta Offset (Skew compensation)	-16 to +16

4. Press **Go** to print the Cyan Alignment Page. Use the top row to determine adjustments. See **“Printhead alignment test page—cyan (three of three)”** on **appendix page B-11** for a color sample of the entire page.
- a. Use the leftmost target in the first row to adjust the cyan and black horizontal lines in the target (T value or Top).

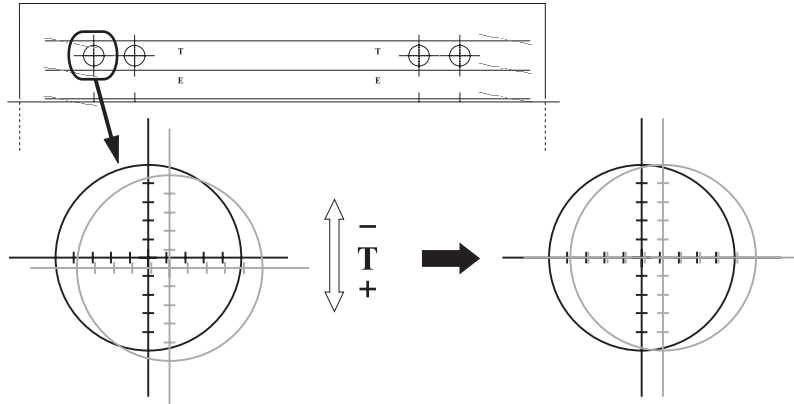

Adjust the setting and press **Go** to print the page and verify the setting, until the lines are even. Press **Select** to save the value. The display advances to the next value.

- b. To adjust Z or theta value. Press **Go** to print the Cyan Alignment Page. Use the rightmost target in the first row to adjust the cyan and black horizontal lines.

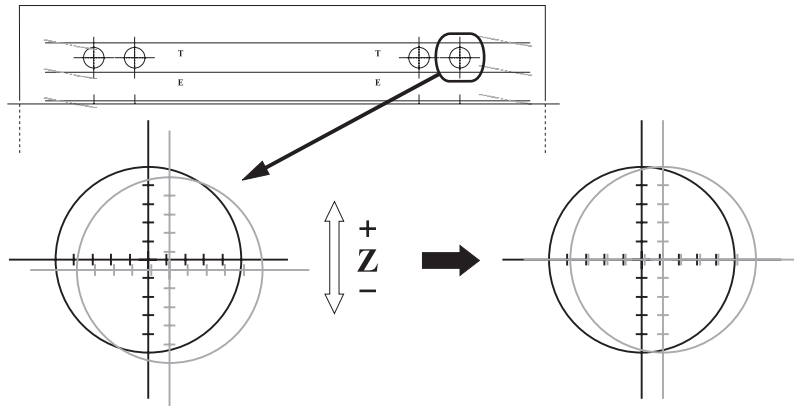

Adjust the setting and press **Go** to print the page and verify the setting, until the lines are even. Press **Select** to save the value.

- c. To adjust R or Right value press **Go** to print the Cyan Alignment Page. Use the rightmost target in the first row to adjust the cyan and black vertical lines.

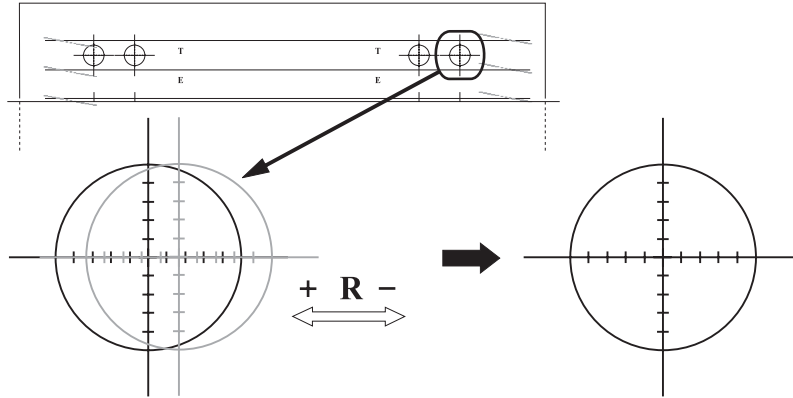

Adjust the setting and press **Go** to print the page and verify the setting, until the lines are even. Press **Select** to save the value.

- d. To adjust L or Left value, press **Go** to print the Cyan Alignment Page. Use the leftmost target in the first row to adjust the cyan and black vertical lines until the targets overlap.

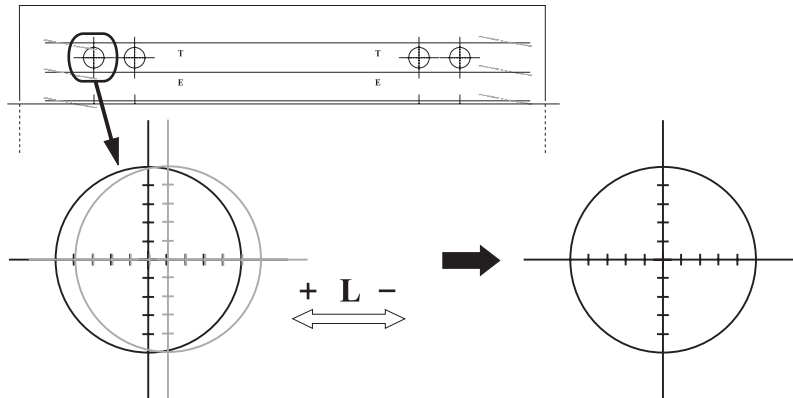

Adjust the setting and press **Go** to print the page and verify the setting, until the lines are even. Press **Select** to save the value.

- e. Change each of the settings (Top, Left, Right, and Theta) for cyan. When the targets are aligned, press **Go** to print the final page.
5. After aligning the cyan targets, press **Return**. Repeat the process to align the Top, Left, Right, Theta for magenta and for yellow. See **“Printhead alignment test pages—magenta (one of three)”** on appendix page B-9 and **“Printhead alignment test page—yellow (two of three)”** on appendix page B-10 for color samples of these pages.

Print line length calibration

1. Press **Return** until you reach the main Diagnostic Menu (the top line is blank and bottom line displays Alignment).
2. Press **Menu** until Print Tests is displayed and press **Select**.
3. Select Print Line Length Calibration.
There are six alignment groups, A through F.

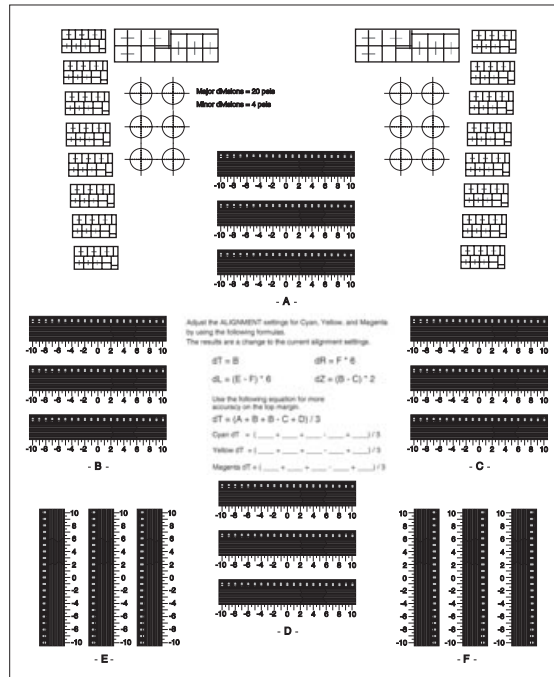

See **“Print Line Len page”** on **appendix page B-12** for a color sample.

4. A color band is visible through the black bars. Locate the center of the color band and determine the value.

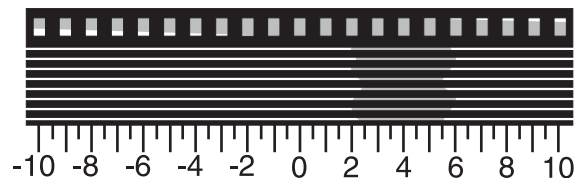

- If all the color bands for cyan, magenta, and yellow on all six groups A through F are centered between -2 and +2, you are done.
 - If the center is located outside the area between -2 and +2, you need to calculate the appropriate alignment adjustment for that color. Continue to the next step.
5. Calculate the Alignment Group values.

Alignment Group	Adjustment Calculation(s)	
A	$dT=(A+B+B-C+D)/3$	---
B or C	$dT=(A+B+B-C+D)/3$	$dZ=(B-C)*2$
D	$dT=(A+B+B-C+D)/3$	---
E	$dL=(E-F)*6$	---
F	$dL=(E-F)*6$	$dR=F*6$

6. After completing calculations for the colors that are beyond -2 and +2 range, return to the Alignment menu. See **“Electronic color alignment”** on **page 4-58**.

7. Select the appropriate color.
8. Change value of the respective setting by the calculated value.
For example, if $T = -5$ and $dT = 2$, the new T value is $(T + dT = -5 + 2) = -3$.
9. Once all values are changed, return to the Print Tests menu and select Print Line Length Calibration.
10. Verify that the adjusted values and the color bands for cyan, magenta, and yellow on all six groups, A through F, are centered between -2 and +2. Repeat if necessary.
Note: The Line Length Calibration must be printed after making any changes to color alignment.
11. Exit diagnostics.

Printhead thermistor card removal

See **“Thermistor card” on page 7-15** for the part number.

Note: A PSD assembly may already exist. It is not necessary to remove an existing PSD sensor card or assembly.

1. Remove the top cover assembly. See **“Top cover assembly removal” on page 4-5**.
2. Disconnect the cable (A) from the thermistor.
3. Remove the two screws (B).

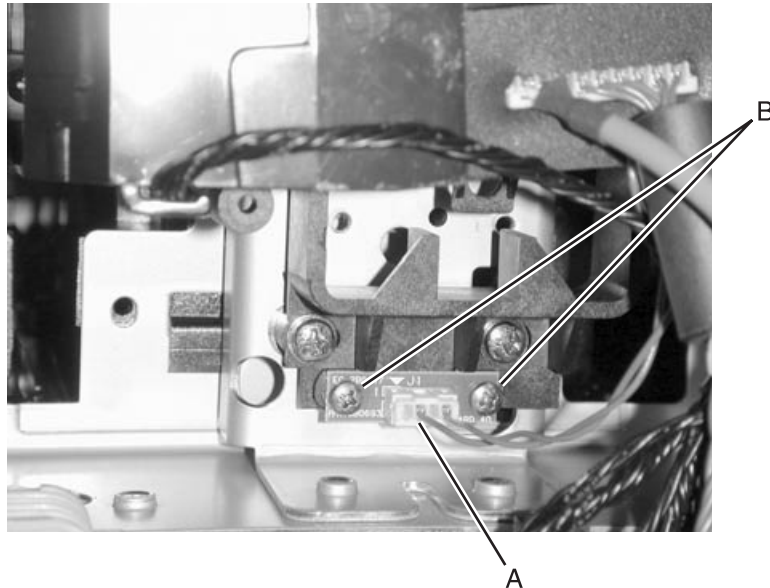

4. Remove the printhead thermistor card.

Installation notes

- If a PSD exists, install the new printhead thermistor card. Leave the old PSD sensor assembly in place.
- Disconnect the cable from the PSD card and connect it to the printhead thermistor card.

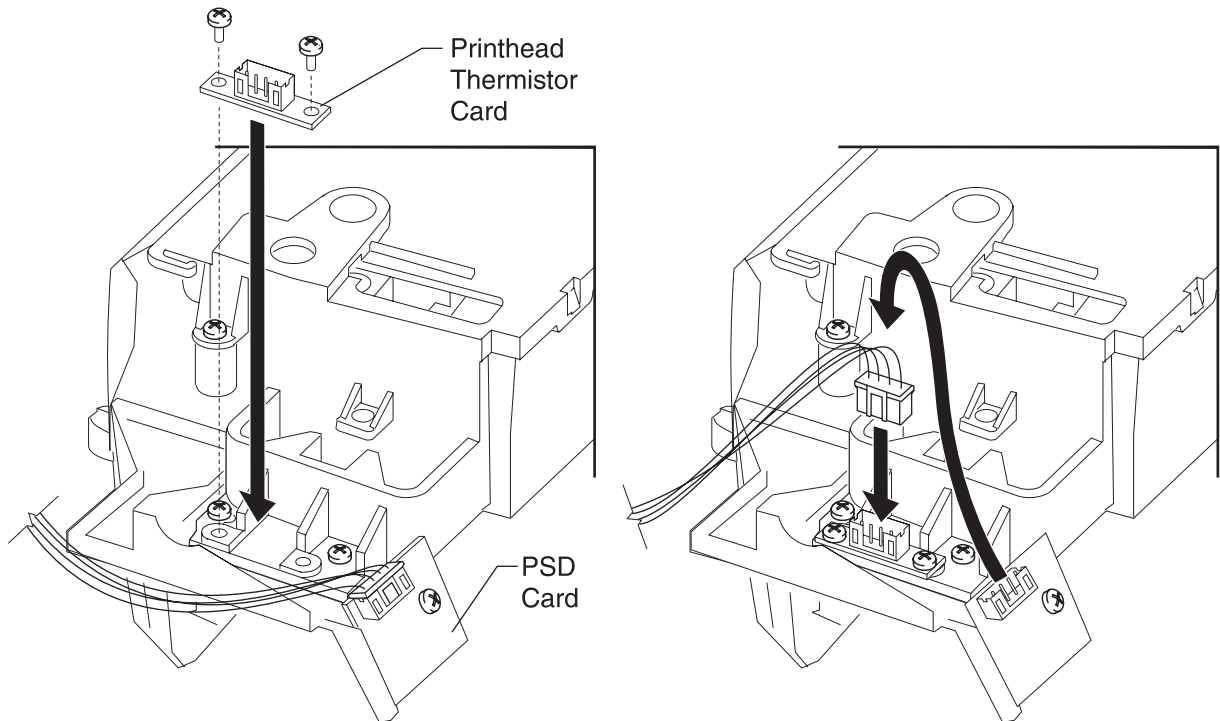

Note: Whether replacing a printhead thermistor or an existing PSD sensor assembly, check the Registration and Color Alignment.

- See **“REGISTRATION”** on page 3-14.
- See **“Electronic color alignment”** on page 4-58
- See **“Print line length calibration”** on page 4-61.

PSD sensor assembly removal

Note: Do not remove the PSD sensor assembly. Replace it with the printhead thermistor card and leave the PSD sensor assembly in place. See **“Printhead thermistor card removal”** on page 4-62 installation information.

Rear bellcrank removal (cyan, magenta, yellow)

See the assembly, **“ITU loading”** on page 7-29, for the part number.

1. Power off the printer.
2. Remove the four toner cartridges and leave the front door open.
3. Remove the ITU assembly. See **“ITU assembly removal”** on page 4-37.
4. Check each of the rear bellcranks for cracks or breakage.

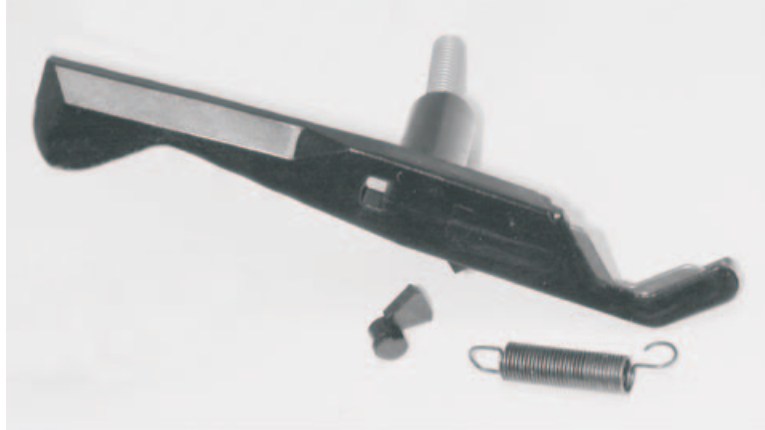

5. Remove the spring (A).

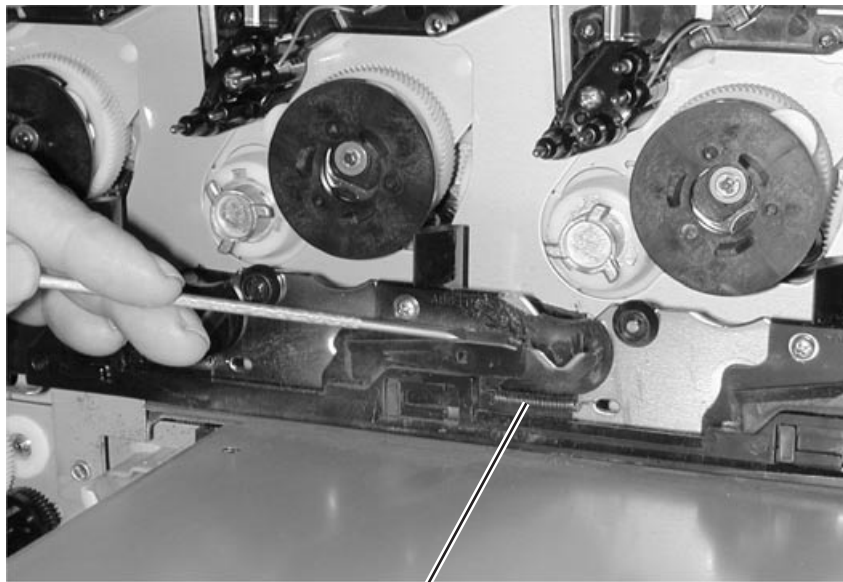

A

6. Rotate the contact end of the bellcrank down (B) and remove. Be careful not to lose the contact spring (C).

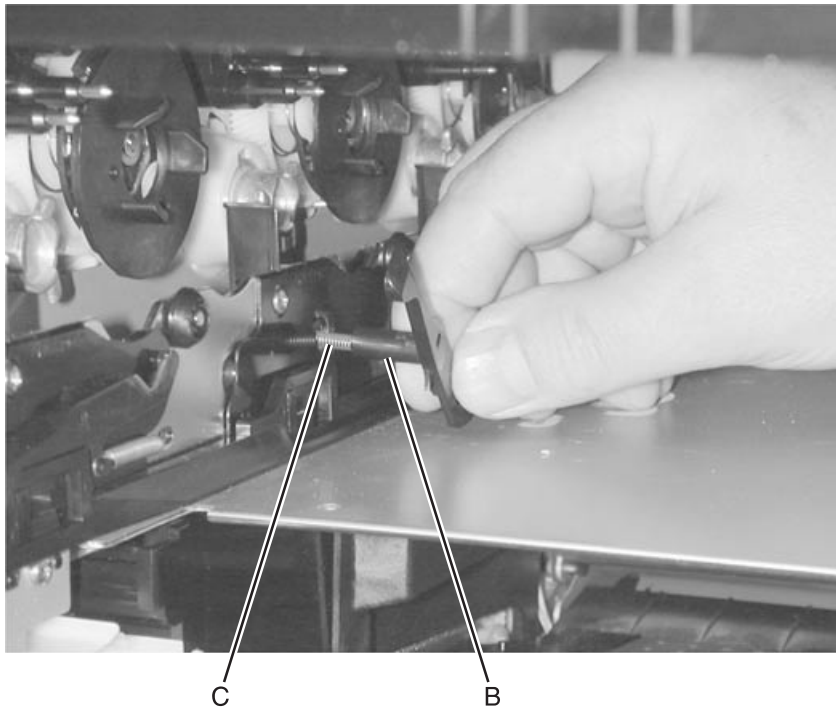

Installation note

Replace the bellcranks by reversing the order of removal.

Note: Test the color coverage by running the Print Quality Pages in the Diagnostics or Configuration Menu.

Rear bellcrank removal (black)

See the assembly, **“ITU loading” on page 7-29**, for the part number.

1. Power off the printer.
2. Remove the four toner cartridges and leave the front door open.
3. Remove **“ITU assembly removal” on page 4-37**.
4. Check each of the rear bellcranks for cracks or breakage.
5. Remove the spring.
6. Remove the stop screw (A) and two washers (B). Be careful not to lose the washers. Recommend using a magnetic tipped screwdriver to remove the screw.

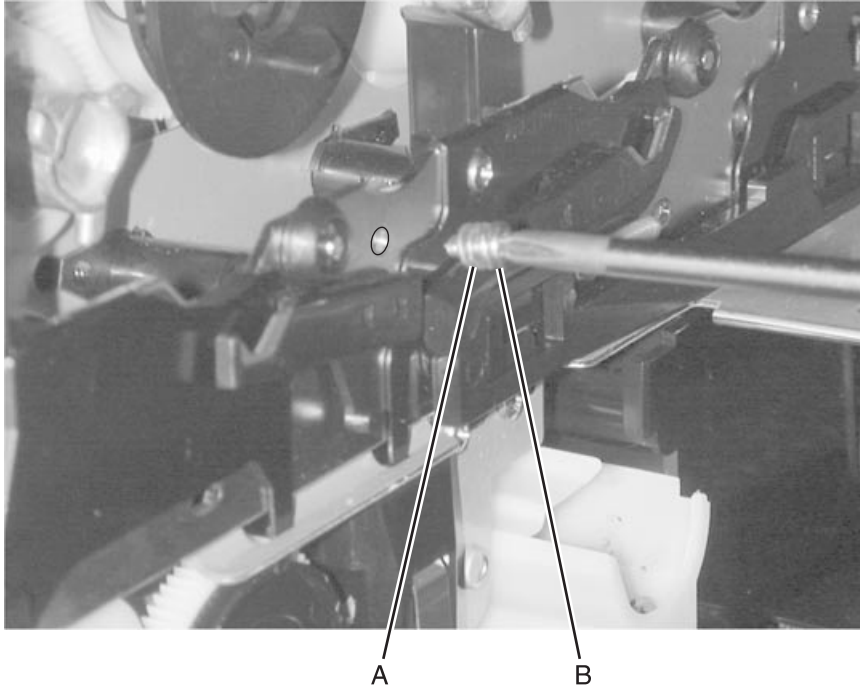

7. Rotate the contact end of the bellcrank down (C) and remove. Be careful not to lose the spring (D).

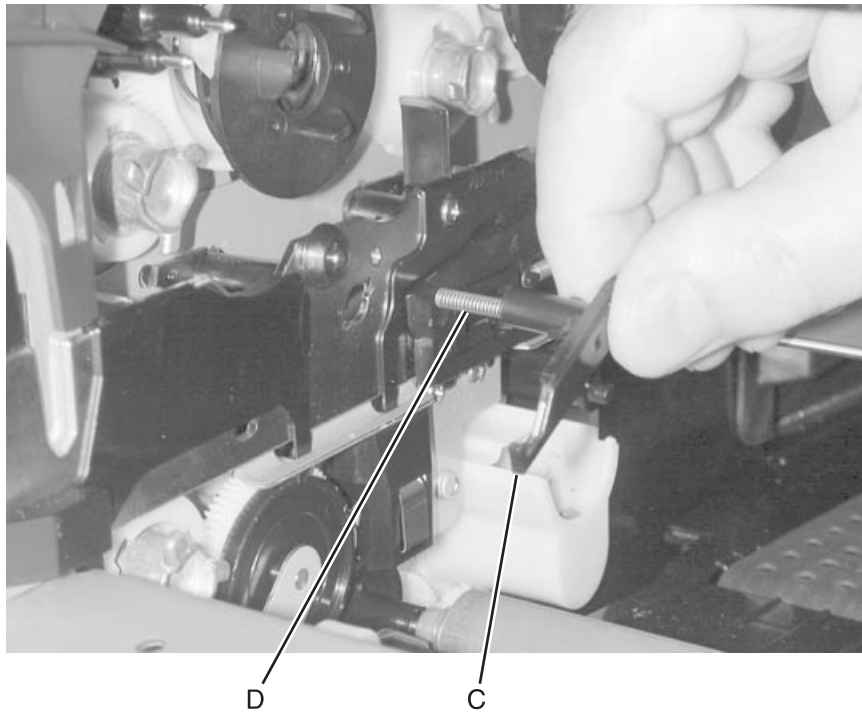

Installation note

Replace the bellcranks by using reverse order of removal.

Note: Test the color coverage by running the Print Quality Pages in the Diagnostics or Configuration Menu.

Redrive assembly removal

See **“Redrive assembly”** on page 7-16 for the part number.

1. Open the redrive door.
2. Remove the redrive assembly screw type **“323”** (A).



A

3. Remove the drive belt (B) from the lower redrive pulley.
4. Remove the redrive assembly.

Note: When you reinstall the redrive assembly be sure to align the notch in the redrive assembly with tab (A).

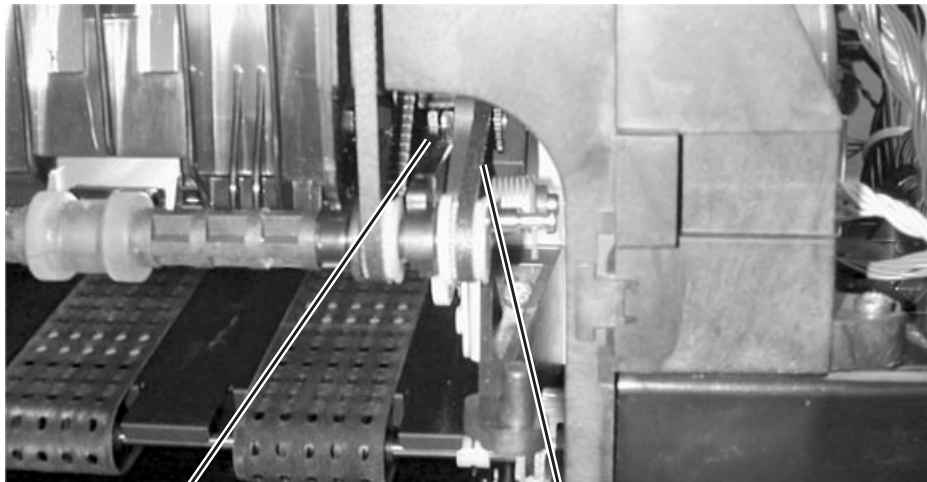

A

B

Registration motor removal

See **“Registration motor”** on page 7-19 for the part number.

1. Remove the rear cover. See **“Rear cover removal”** on page 4-8.
2. Remove the transfer HVPS. See **“Transfer HVPS board removal”** on page 4-80.
3. Remove the registration motor mounting screws (B), cut the cable tie (A), and remove the assembly.

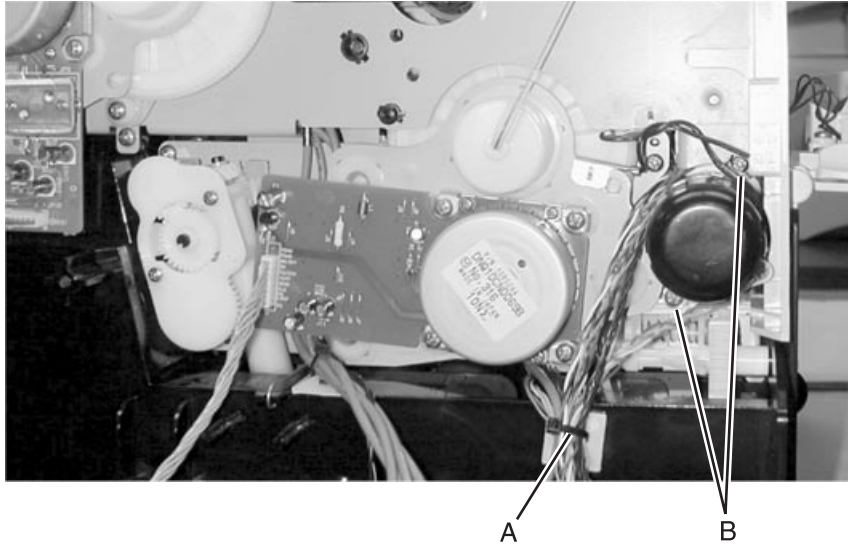

RIP board removal

See **“RIP board assembly - network, model 5060-002” on page 7-37** or **“RIP board assembly, non-network, Model 5060-001” on page 7-37** for the part number.

Warning: Improper RIP board replacement can result in incorrect printer function and significant additional service time due to loss of data.

Warning: Also if both the RIP and engine boards are being replaced, DO NOT replace both at once. Replace one board at a time, following appropriate procedures for each.

1. Remove the outer EMC shield. See **“Outer EMC shield removal” on page 4-47**.
2. Remove the rear cover. See **“Rear cover removal” on page 4-8**.
3. Remove the USB connector screw type **“232” (A)**.
4. Remove the RIP board screw type **“232” (B)**.
5. Remove the parallel connector (C).
6. Disconnect all cables from the RIP board and remove the board.

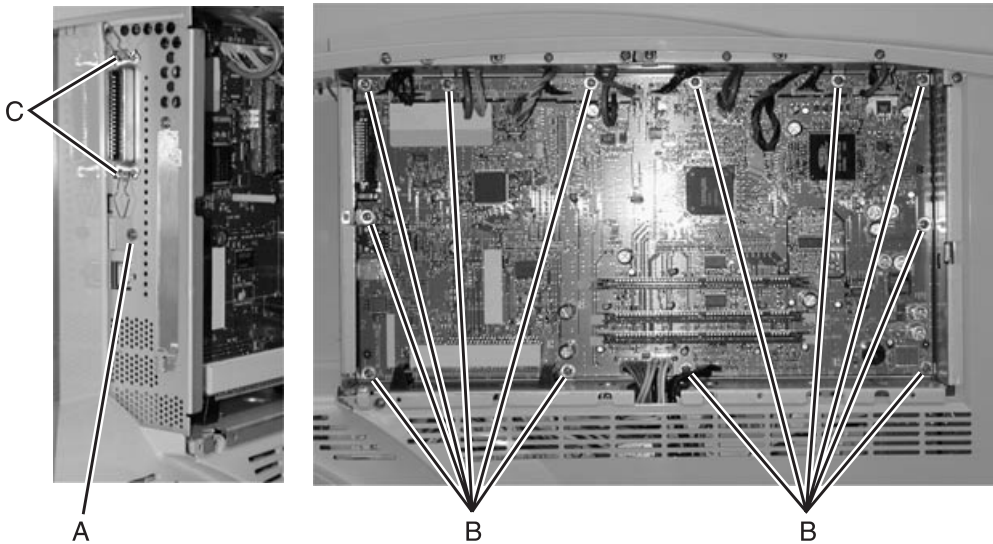

Installation notes

Perform the following steps to install the replacement RIP board:

1. Turn off the printer.
2. Install the replacement RIP board.
3. Turn on the printer.
4. When the operator panel prompts NV Rip to Eng, choose STOP. This prevents transfer of data from the RIP board to the engine board.
5. When the operator panel prompts NV Eng to Rip, choose GO. This transfers data from the engine board to the RIP board. The printer restarts at this point.
6. At the READY prompt, print a Menu page and look for the correct printer name and equivalent/updated RIP code level. The Menu page prints with acceptable print quality indicating calibration data has been properly preserved.

RIP fan removal

See **“RIP fan”** on page 7-41 for the part number.

1. Remove the top cover assembly. See **“Top cover assembly removal”** on page 4-5.
2. Remove the rip fan screw type **“324”** (A).
3. Disconnect the rip fan cable from the engine board at connector J53.
4. Remove the rip fan.

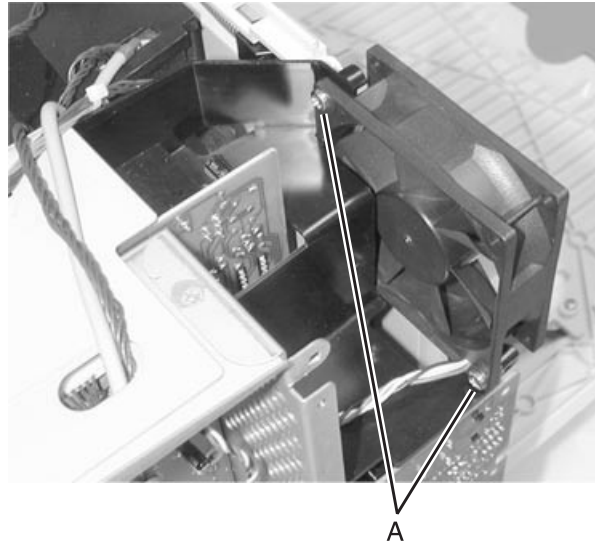

RIP board shield assembly removal

“RIP board shield assembly” on page 7-37 for part number.

1. Remove the top cover assembly. See **“Top cover assembly removal”** on page 4-5.
2. Remove the rear fan cover. See **“Rear fan cover removal”** on page 4-8.
3. Remove the rear cover. See **“Rear cover removal”** on page 4-8.
4. Remove the RIP board. See **“RIP board removal”** on page 4-70.
5. Remove the transfer HVPS board. See **“Transfer HVPS board removal”** on page 4-80.
6. Remove the RIP board shield assembly mounting screws (A) through the holes in the shield.
7. Remove the RIP board shield assembly.

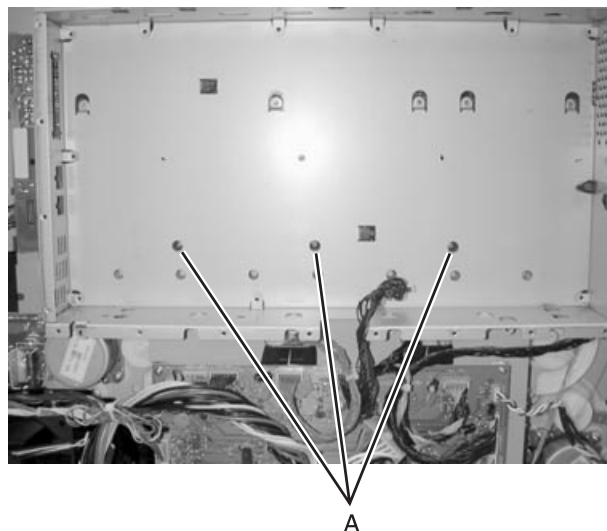

S2/NMS/transparency sensor assembly removal

The S2, narrow media sensor (NMS), and transparency sensor are bundled into a sensor cable assembly. See **“S2/transparency/narrow media sensor assembly”** on page 7-17 for the part number.

Removing the old assembly

Note: Disconnect all power from the printer before proceeding with the steps below.

1. Open the front cover and remove the print cartridges.
2. Open the multipurpose feeder (MPF) door.
3. Remove the ITU assembly.
4. Remove the right rear cover.
5. Disconnect connector J70 (A) to the MPF sensor from the system board.

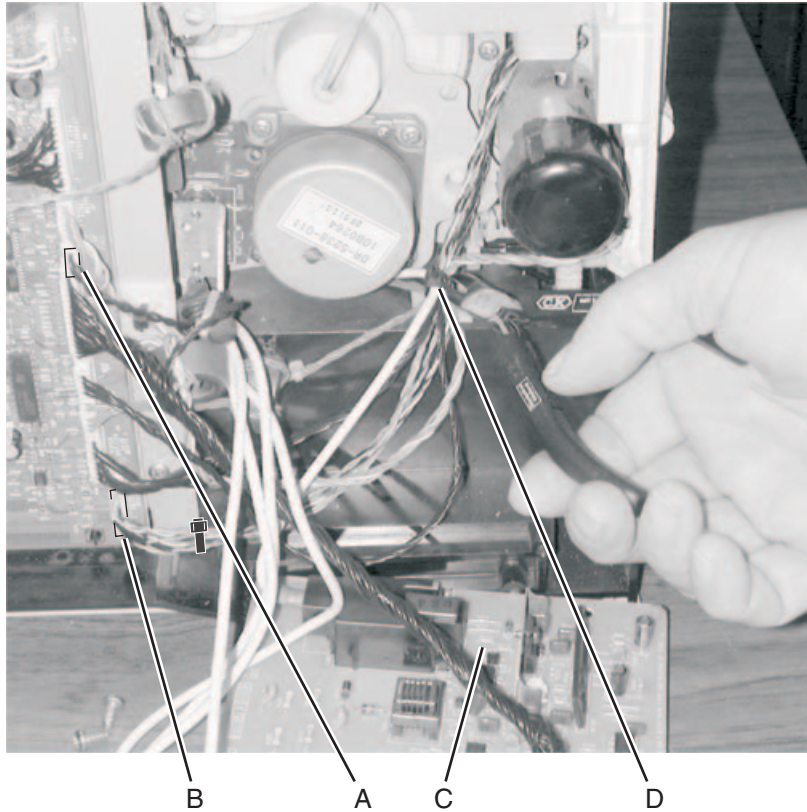

6. Remove the screws from transfer high voltage power supply (C) and lay it down out of the way.
7. Cut the cable tie (D) which holds the cable bundle so you can remove the sensor cable assembly. Cut any cable tie restraining the cable to J68.

Note: Note the location of any cable ties so they can be replaced later.

Warning: Use care not to cut or nick any cables when removing the cable ties.

8. Disconnect J68 (B) from the engine board.
9. Cut the connector J68 off the old sensor cable assembly to make removal easier.

10. Disconnect the MPF assembly door hinge restraint by removing screw (E) and remove the MPF assembly.



11. Gently pull the sensor assembly cable (B) through the opening between the upper and lower frame and remove the sensor assembly through the rectangular opening.
12. Clip and remove the cable tie (C).

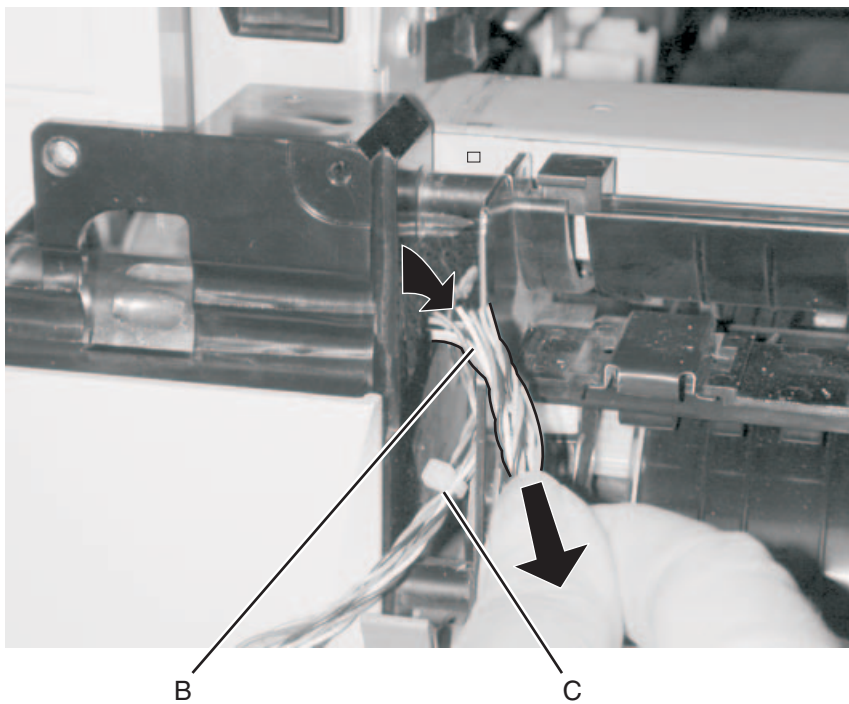

13. Disconnect the three sensors (A) from the frame.

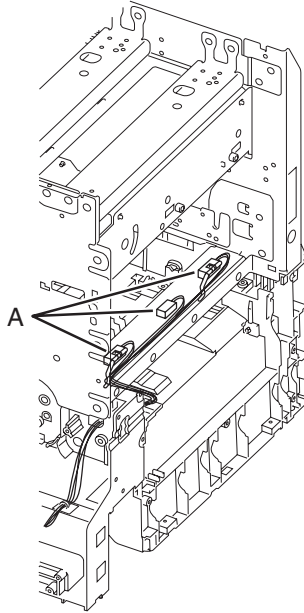

Service tip: A light aimed toward the grounding clip (B) makes the removal easier.

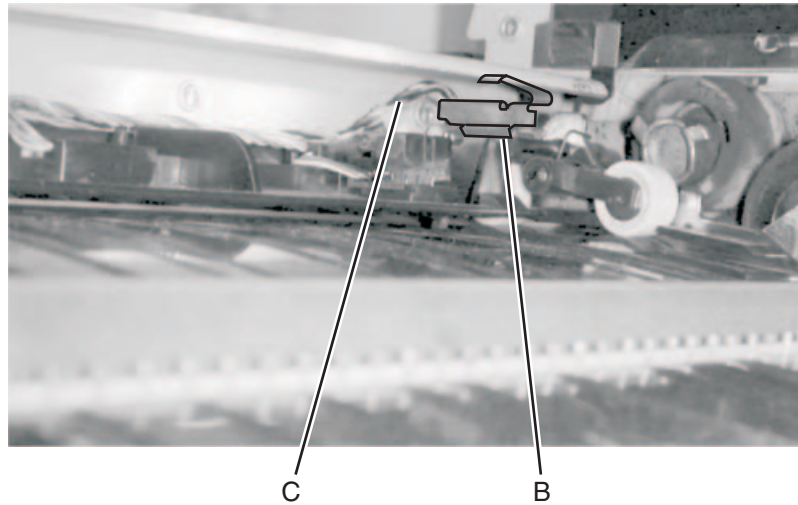

- Service tip:** Leave the old sensor cable assembly (C) in place temporarily after disconnecting the sensors as a guide to placement of the sensors for the new assembly. Lay the new sensor cable assembly beside the old one and connect the new sensors as you remove the old assembly. The new sensor cable assembly is installed on the other side of the grounding clip (closer to the fuser), so you do not have to reinstall the new sensor cable assembly between the clip and upper frame channel.
14. Pull the old sensor cable assembly to remove it. Observe the routing of the cable, especially the location of the cable (C) around the grounding clip (B). The new cable will be installed on the opposite side of the clip. Pulling too firmly on the sensor cable assembly may unseat the grounding clip. The old cable assembly runs between the frame and the grounding clip.

Installing the new assembly

1. Remove the J70 connector cable to allow space. Note the route it shares with sensor cable assembly through the frame (see openings D and E below).
2. Place a new cable sensor assembly in the printer next to the sensor connectors (A).
3. Route the J68 connector around the ground clip (B) and cable channel between the upper and lower frame.
4. Route the J68 cable connector through the rectangular opening (D) in the lower frame and out through the opening (E).

Note: Guiding the cable through the small opening requires some patience. Use the diagram below and the steps following as a guide.

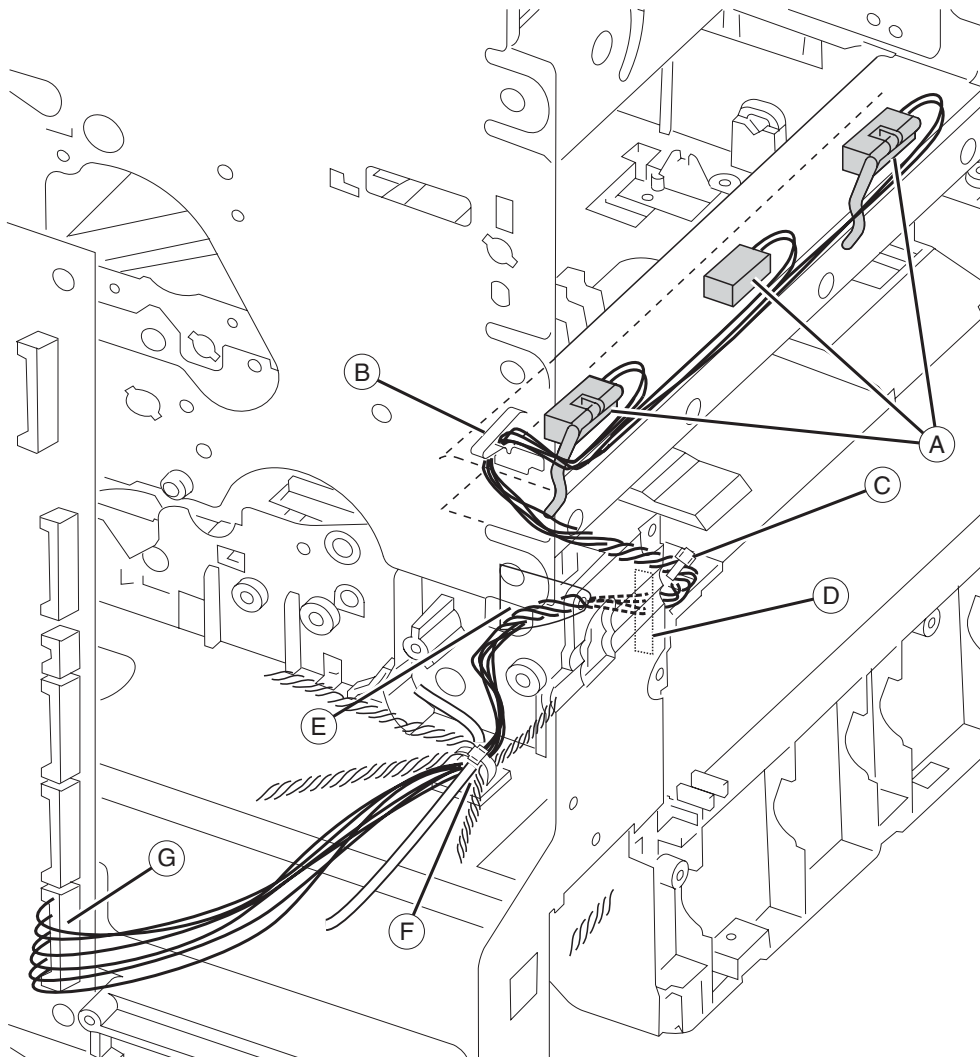

- A –Sensors, part of sensor cable assembly
- B –Grounding clip
- C –Cable tie
- D –Rectangular opening
- E –Opening
- F –Cable tie
- G –J68 connector, sensor cable assembly

Insert the cable connector into the rectangular opening and twist left and push up gently, the connector tends to follow the pathway through and out.

- a.** Insert the J68 connector of the sensor cable assembly into the rectangular opening and push up.

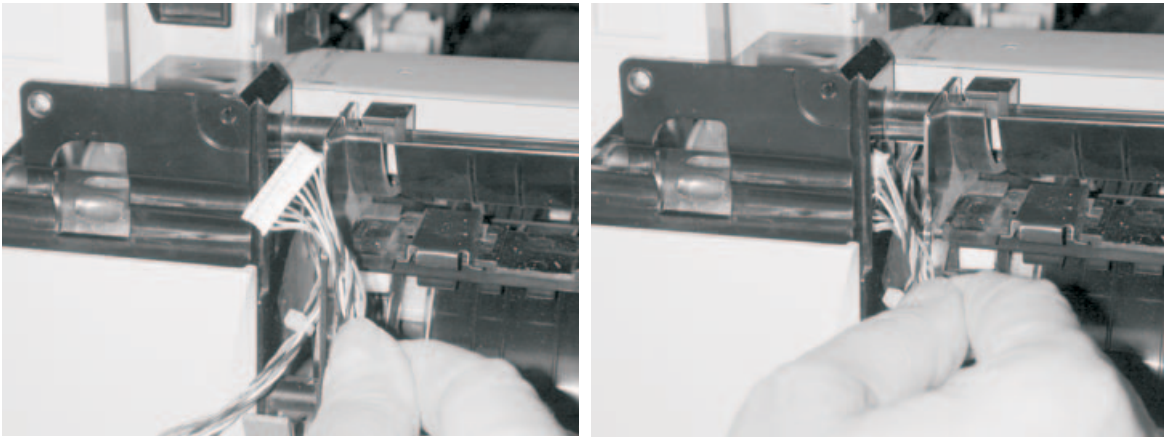

- b.** With your other hand, twist the sensor cable assembly toward the left and continue guiding the cable up.

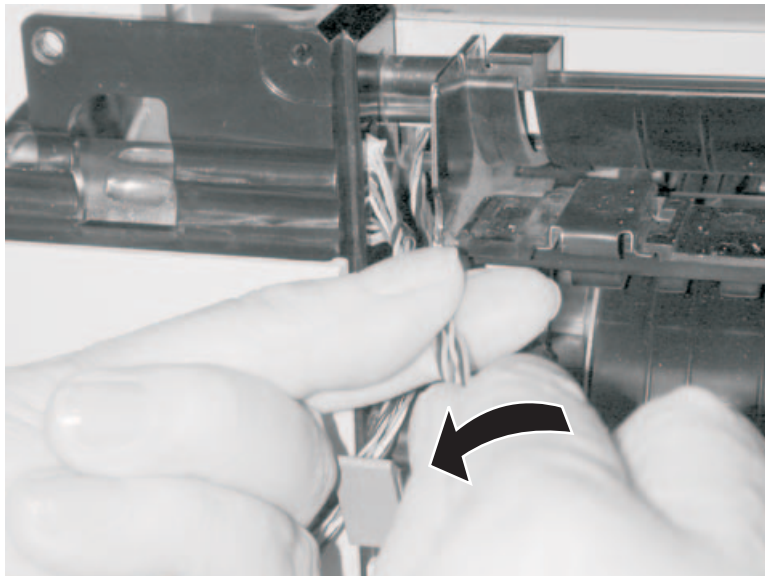

C. Continue to push until the J68 connector (A) appears in the opening.

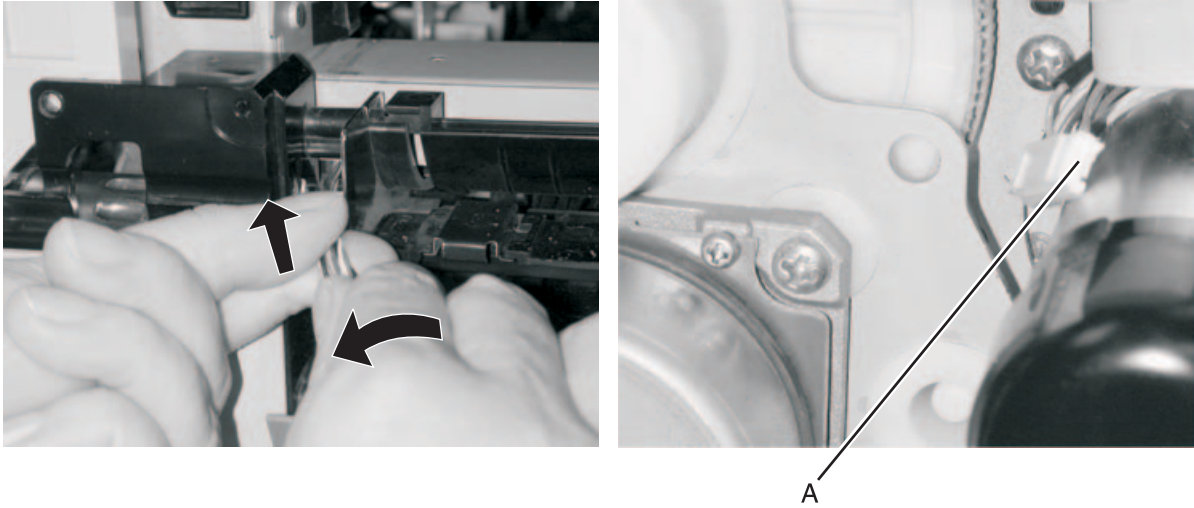

5. Route the MPF tray assembly sensor cable through the same openings.
6. Connect J68 to the engine board.
7. Connect the MPF tray assembly sensor cable to the engine board at J70.
8. Install the new cable tie (B) on the cable bundle and trim the excess cable tie flush. Replace other cable ties you removed in earlier steps.



9. Ensure the sensor cable assembly is on the side of the grounding clip (A) closest to the fuser end of the printer.

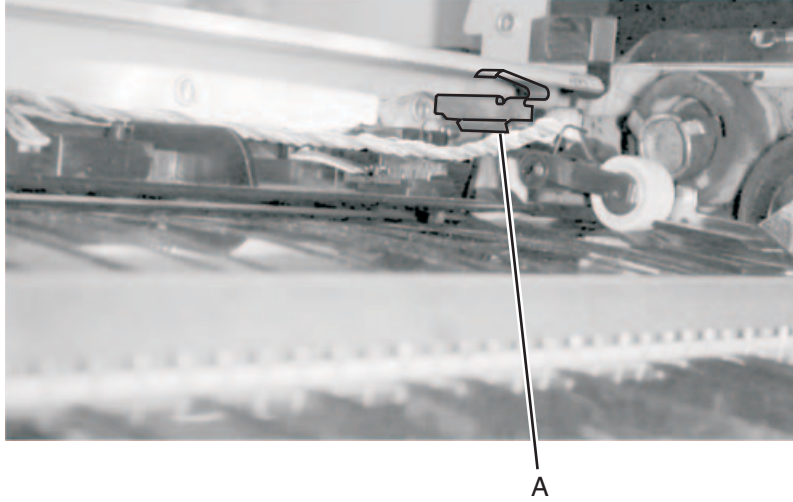

10. Install the new sensor assembly (B) in the lower frame.

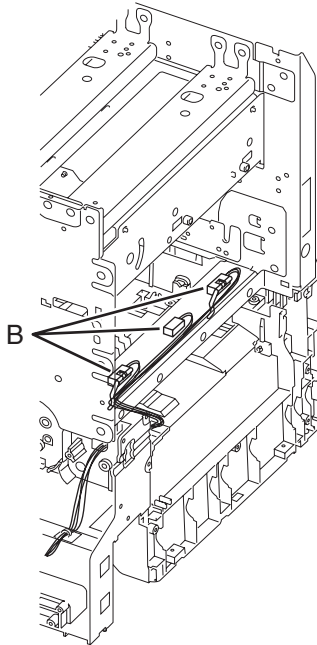

11. Verify the sensors flags are not sticking and are moving freely.
Service tip: Use a sheet of paper between the upper and lower guides to activate the sensors.

12. Install a new cable tie in the same location as the one that was previously removed (B), if necessary.

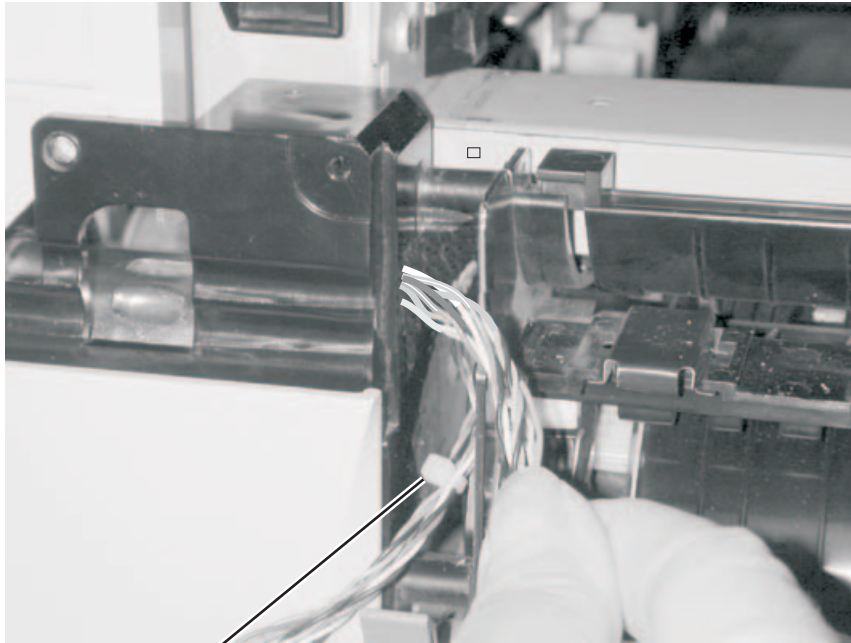

A

13. Install the MPF tray assembly and replace the screw to reconnect the MPF assembly door hinge restraint.
 14. Install the ITU and print cartridges.
 15. Reconnect power to the printer.
 16. Run the print test to check for correct operation before replacing the right rear cover.
 17. Replace the right rear cover.

Second transfer roll removal

See **“Second transfer roll”** on page 7-14 for the part number.

1. Remove the ITU assembly. See **“ITU assembly removal”** on page 4-37.
2. Lift the transfer roll from the front bearing and remove the transfer roll.

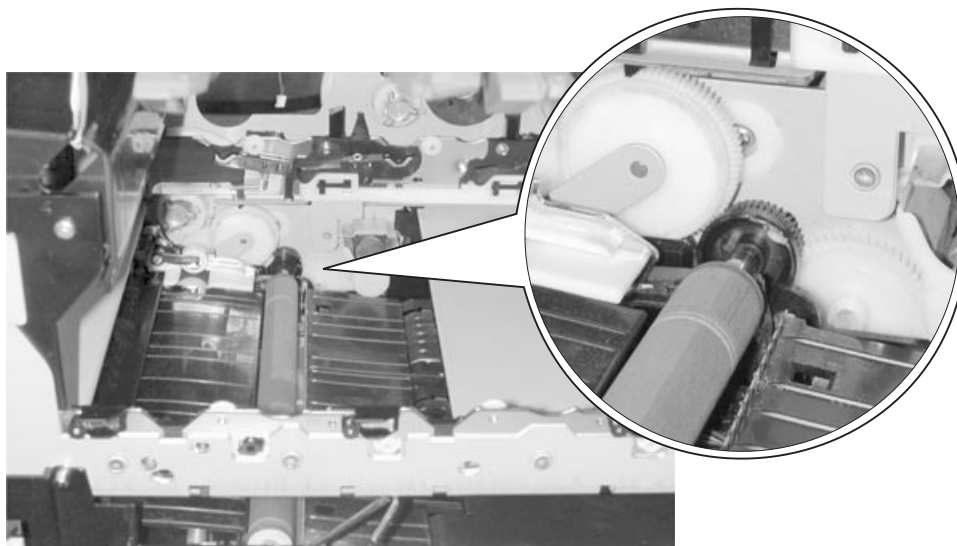

Transfer HVPS board removal

See **“Transfer HVPS board” on page 7-38** for the part number.

1. Remove the rear cover. See **“Rear cover removal” on page 4-8**.
2. Remove the transfer HVPS board screw type **“324”** and **“312”** (A).
3. Disconnect the five spade terminals (B) from the transformers.
4. Disconnect the control cable (C).
5. Remove the board.

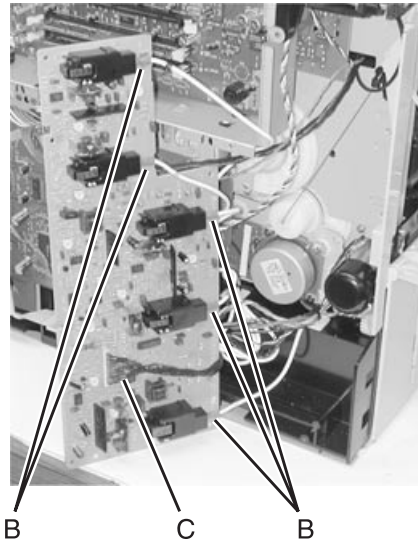
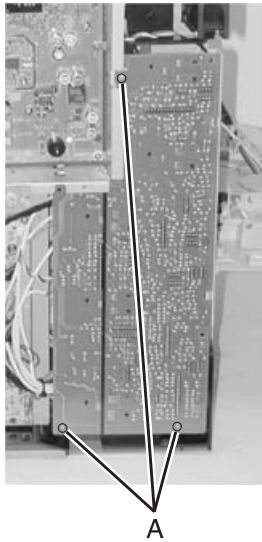

Transfer plate assembly

See **“Transfer plate assembly”** on page 7-14 for part number.

1. Remove the **“S2/NMS/transparency sensor assembly removal”** on page 4-72.
2. Remove the transfer plate. Lifting and rotating the right edge of the plate up to a 45° angle releases the transfer plate. Remove the grounding strap (A) attached to the bottom of the transfer plate.

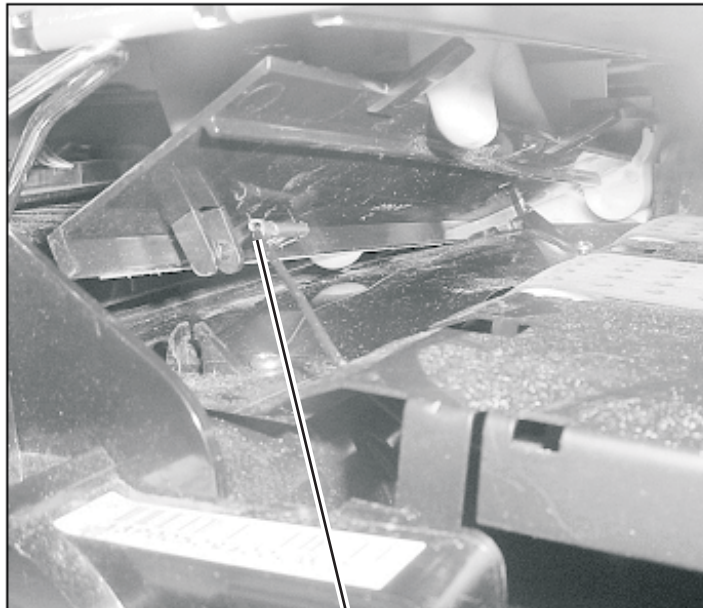
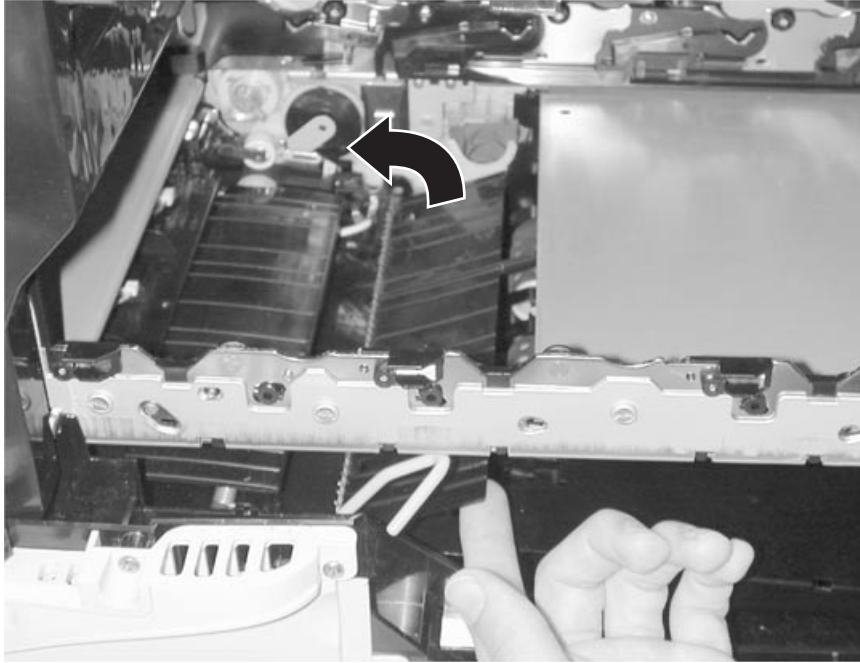

A

3. Remove the transfer plate assembly.

Vacuum transport belt (VTB) removal

See “**Vacuum transport belt assembly**” on page 7-13 for part number.

1. Remove the transfer plate assembly. See “**Transfer plate assembly**” on page 4-81.
2. Remove the fuser bottom duct. See “**Fuser bottom duct removal**” on page 4-32.
3. Remove the two front screws (A).

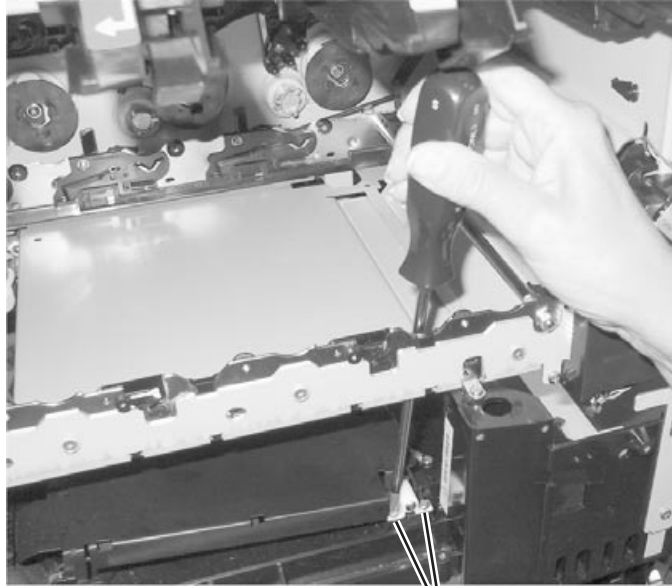

A

4. Loosen belt (B) on redrive assembly and remove from redrive gear.
5. Remove belt from gear on vacuum belt transfer unit.

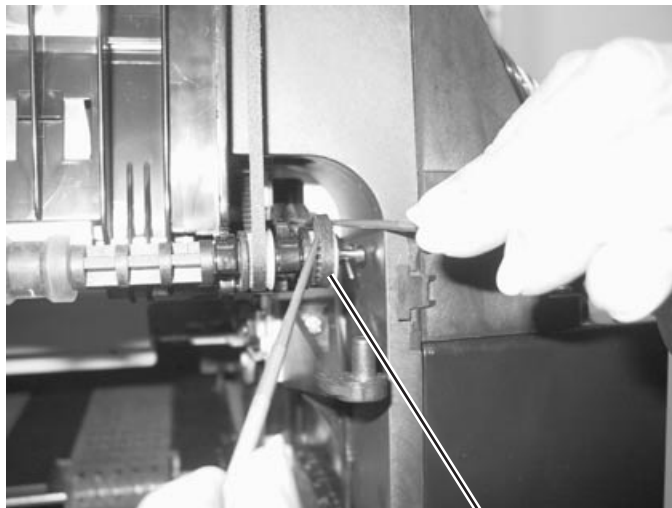

B

6. Rotate release lever on gear until the gear can be removed.

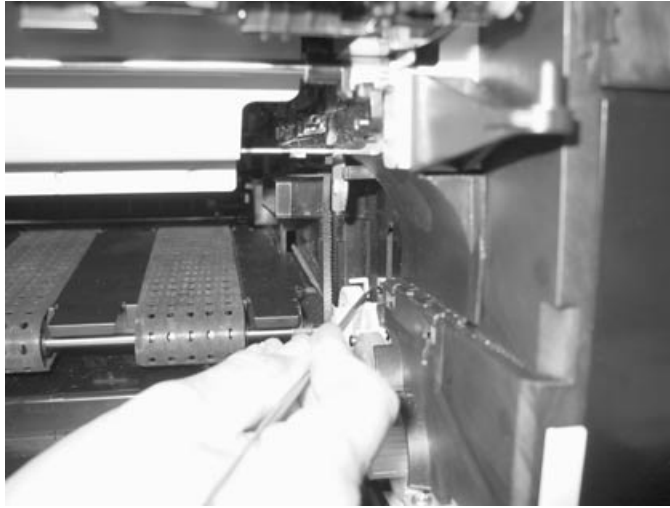

7. Remove screw from ground wire.



8. Remove vacuum belt transfer belt unit far enough to release ground wire from restraint clips and remove completely.



Vacuum transport belt (VTB) fan removal

See **“VTB fan” on page 7-41** for the part number.

1. Remove the RIP board shield assembly. See **“RIP board shield assembly removal” on page 4-71**.
2. Remove the VTB fan with a flatblade screwdriver.

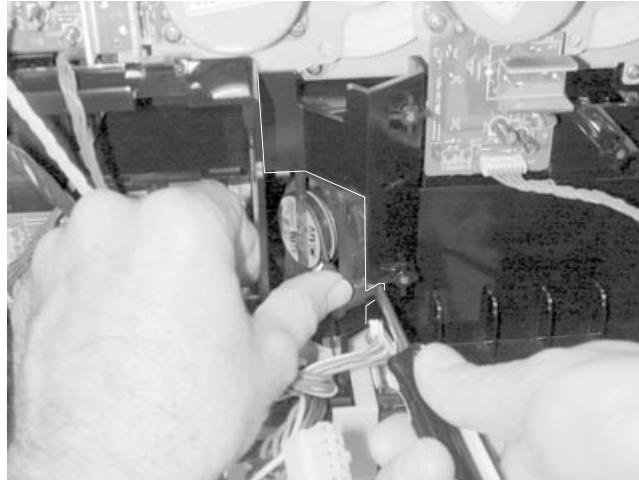

Waste container door removal

See **“Waste container door” on page 7-5** for the part number.

1. Open the waste container door.
2. Flex the door and remove it from the hinges (A).

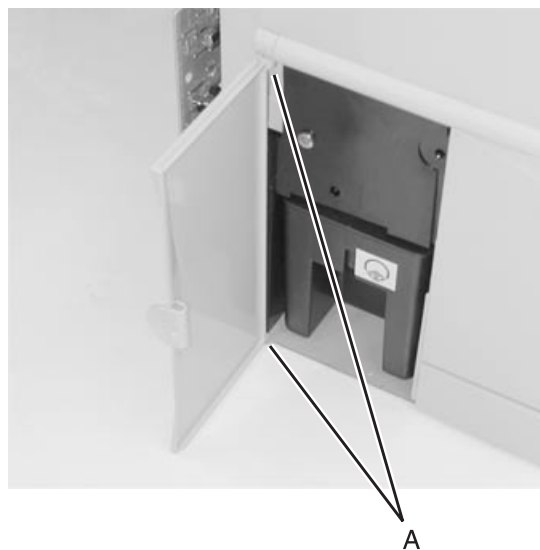

Waste container latch removal

See “**Waste container latch**” on page 7-18 for the part number.

1. Remove the paper size sensing assembly. See “**Paper size sensing assembly removal**” on page 4-48.
2. Use a flatblade screwdriver to release the waste container latch from the paper size sensing assembly.

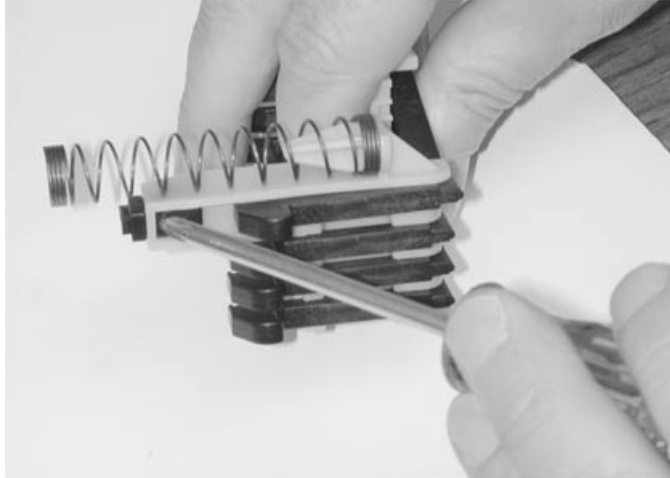

Web oiler fuser kit installation

See “**Fuser web oiler upgrade kit and replacements**” on page 1-4 for the part number.

1. Enter CE Diagnostic mode.
2. Select **Printer Setup**.
3. Select **Configuration ID**.
4. Increase the last two digits each by four.

Configuration ID =123456*

The left digit blinks, indicating it is the first digit to be changed. Press **Select** to accept the current value and skip to the next digit. Change the two digits on the right to increase each of their values by four. For example, in this case, change 1234**56** to 12349A. To change the value of a digit, press **Menu** until the desired value is displayed and press **Select**. When the last (rightmost digit) is changed and **Select** is pressed, the new value is set. The printer automatically begins POR.

5. Turn the printer off.
6. Open the fuser access cover.

7. Unlatch the two fuser latches (A).

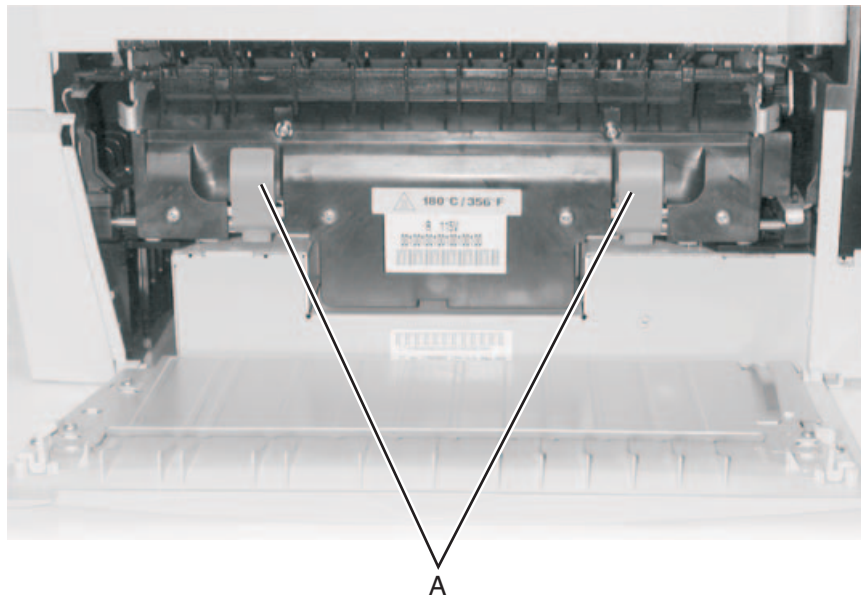

8. Remove the fuser assembly.
9. Open the front cover.
10. Remove the yellow print cartridge.
11. Remove the front right light shield screws (B) and (C) and remove the light shield.

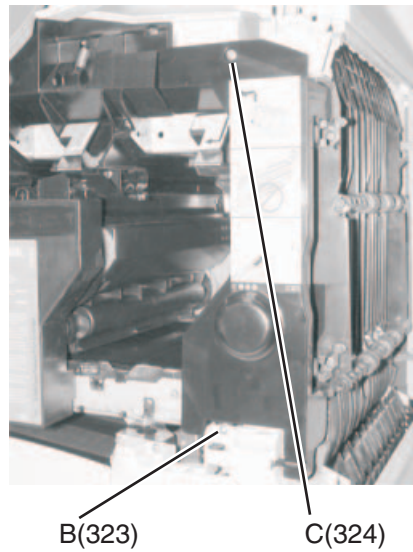

12. Carefully remove the paper path access door cover right mounting screw (D).



D(323)

13. Tape front jam access door (E) if tape is available, to help hold the door in place.



E

14. Remove the front right handle cover assembly screws (F) and remove the assembly.

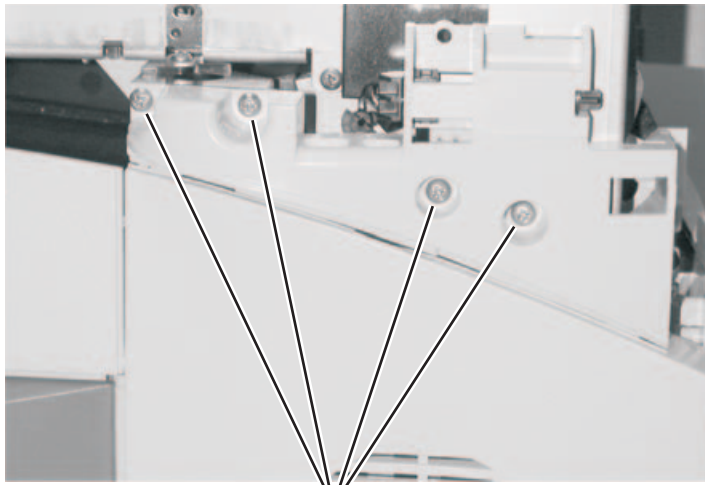

F(323)

15. Open paper tray (G).



G

16. Remove screw (H) from the top front support bracket. Swing bracket to the right.

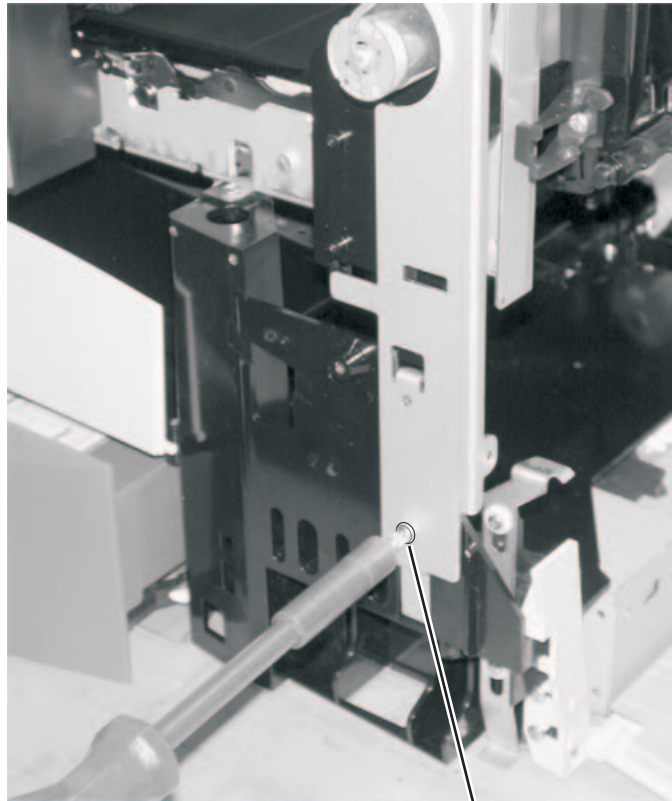

H

17. Use the alignment pins (I) on the web oiler fuser motor assembly to position the assembly in holes (J) and install the assembly.

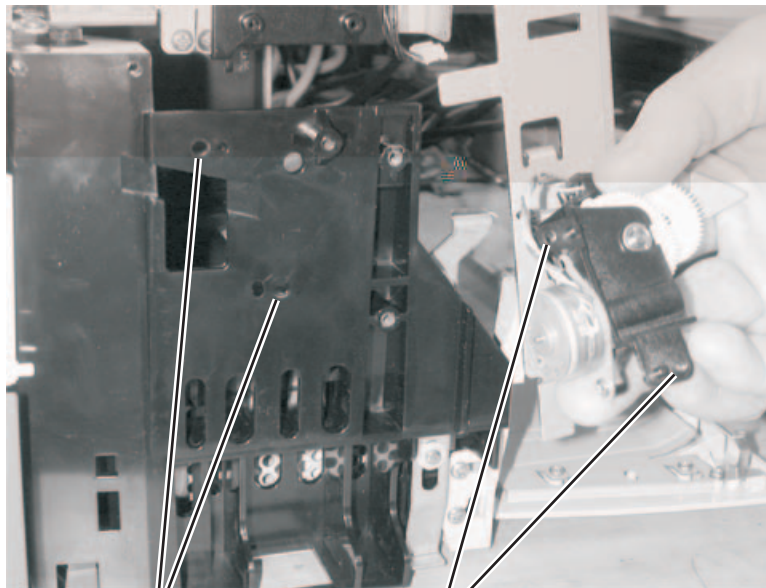

J

I

18. Secure the web oiler motor assembly with screws (K).

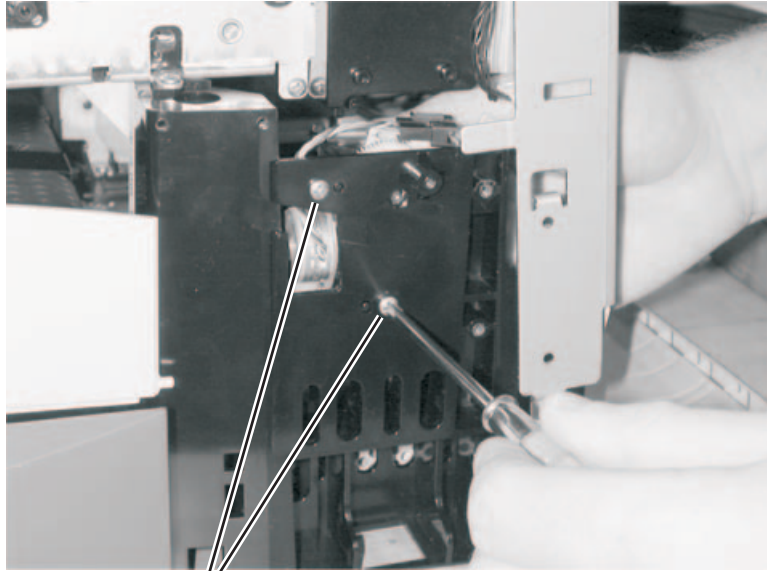

K

19. Install the web oiler card using screws (L).

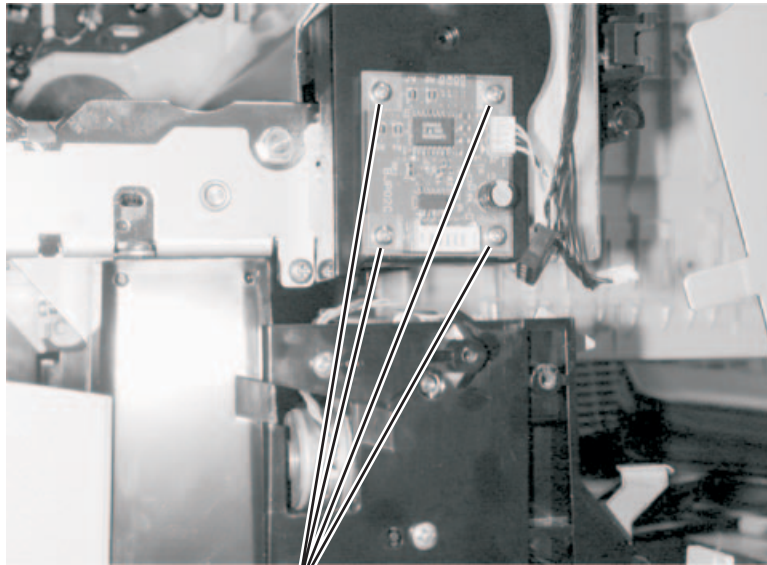

L

20. Plug web oiler cable into web oiler card connector (M). Plug web oiler drive assembly cable into cable connector (N).
- Note:** Make sure the cables from the drive assembly are routed along the lower frame and are not in contact with the drive assembly gears.

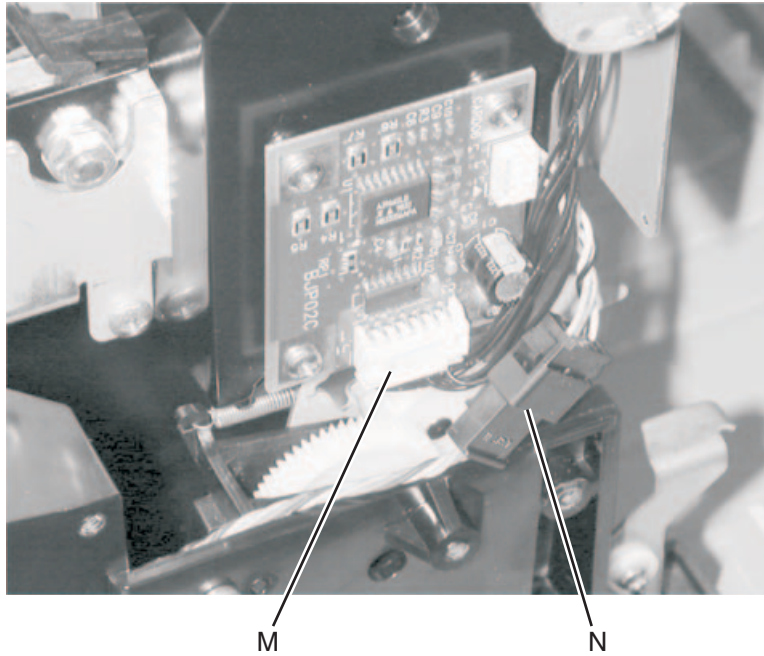

21. Reinstall paper path access door.

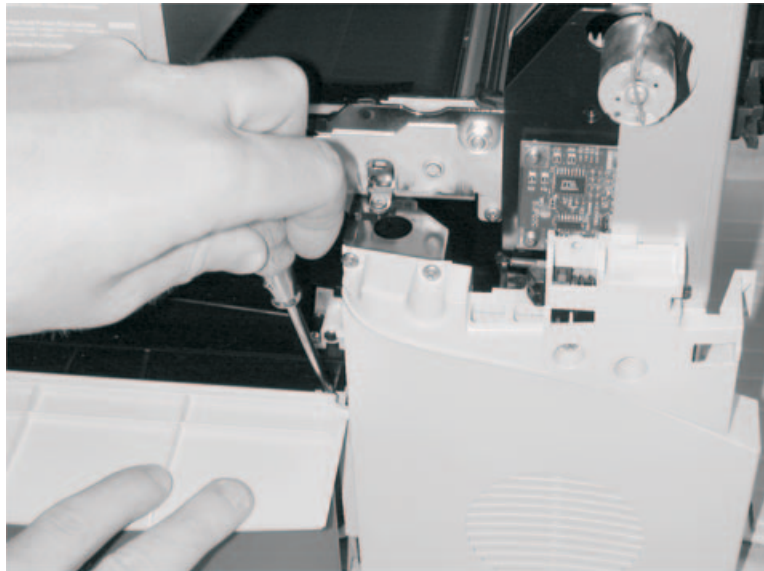

22. Align tabs on the front right light shield with the slots (O) on the frame.

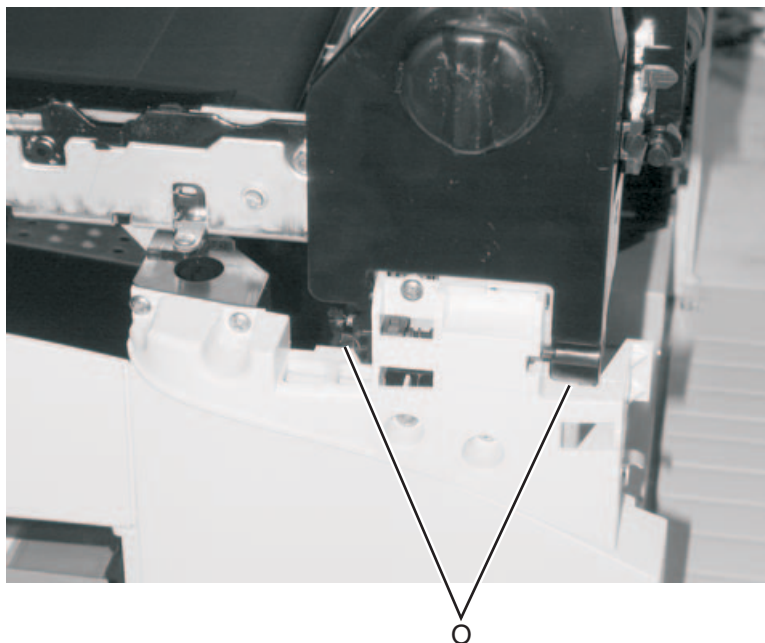

23. Move the front right light shield up until alignment stud (P) and the screw hole (Q) are aligned.

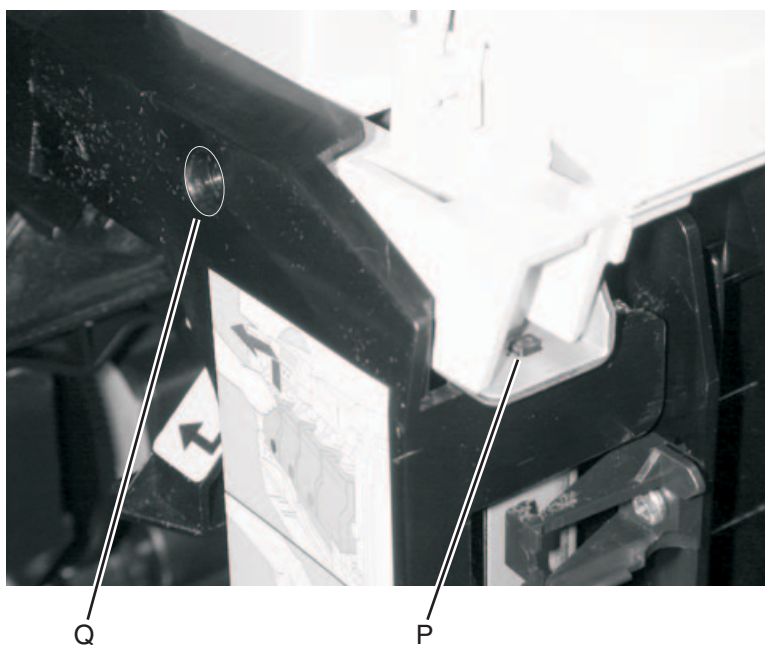

- 24.** Attach the new fuser web oiler fuser housing (R) to the new web oiler fuser.

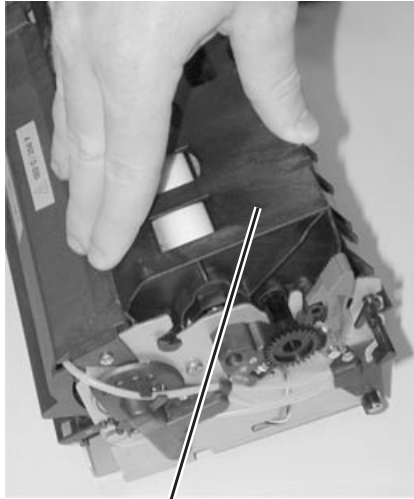

R

- 25.** Insert the web oiler fuser assembly into the fuser assembly and install the fuser assembly into the printer.

5. Connector locations

Locations

Printer boards

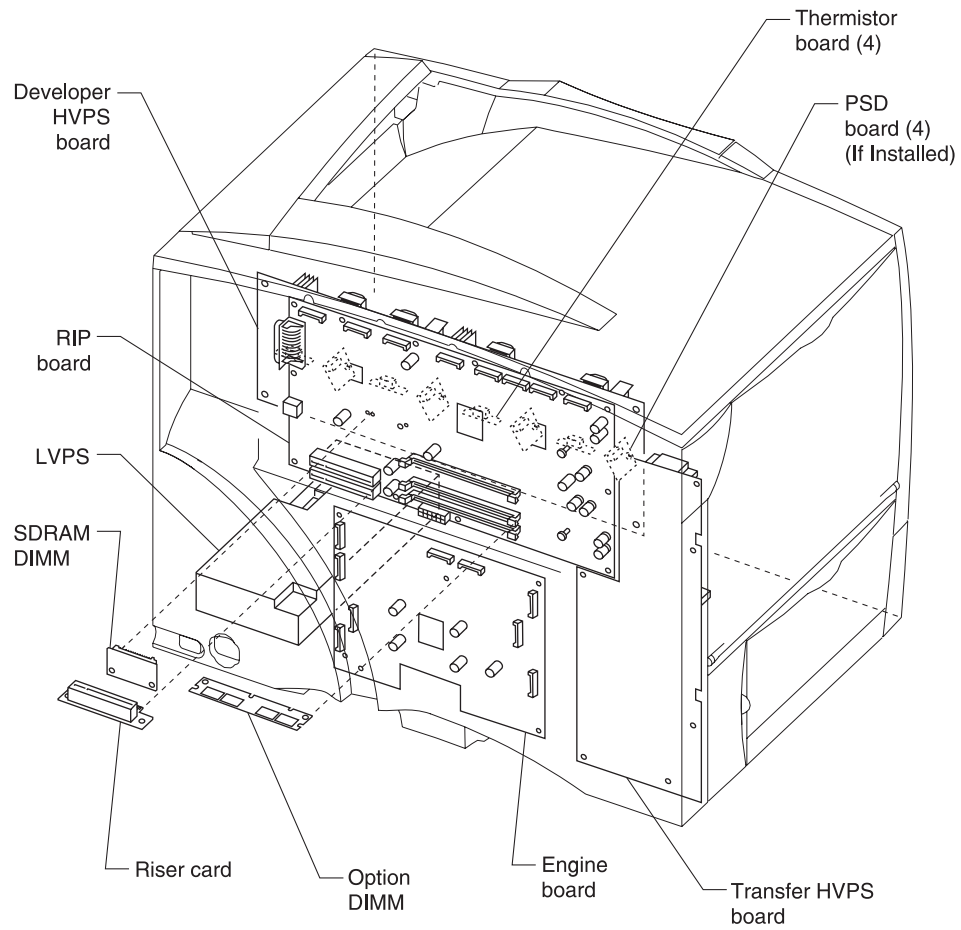

Printer motors

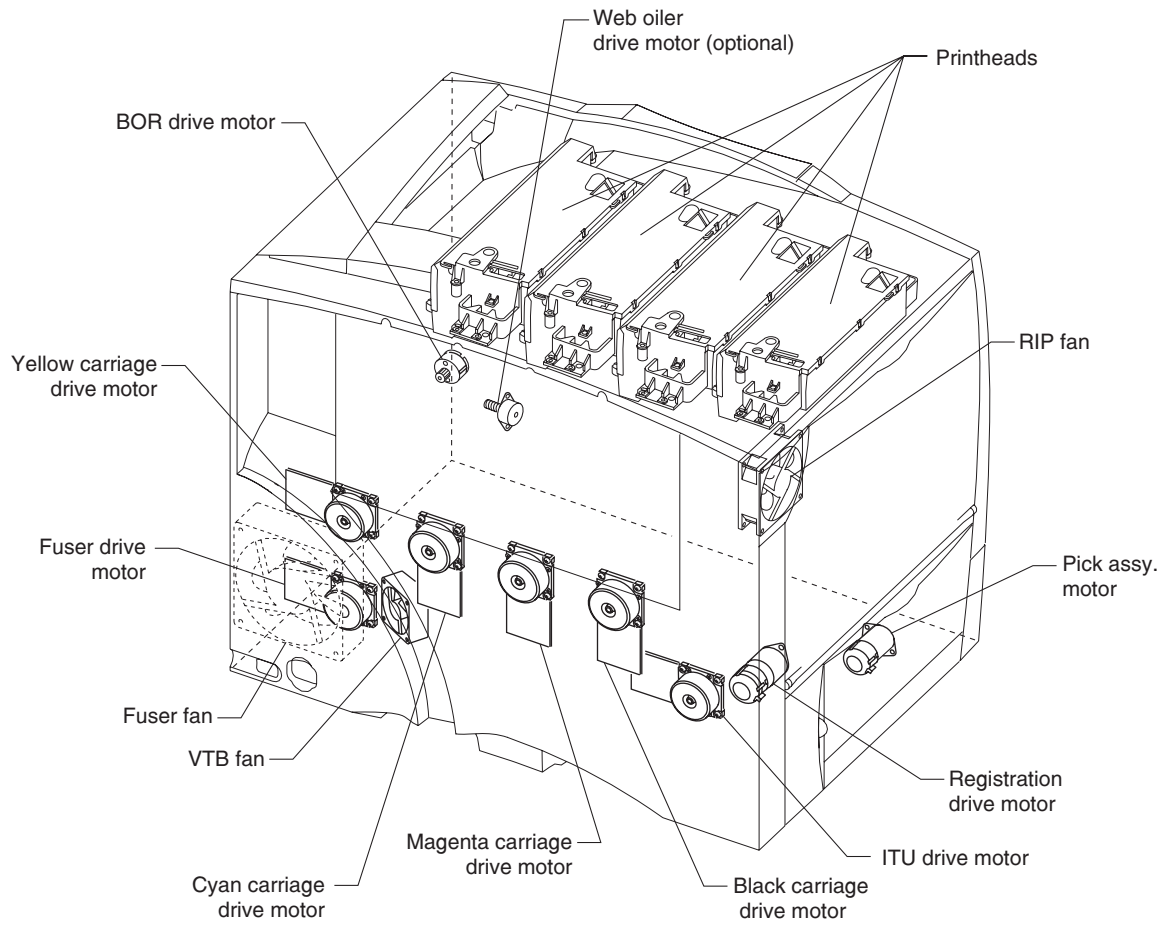

Printer sensors

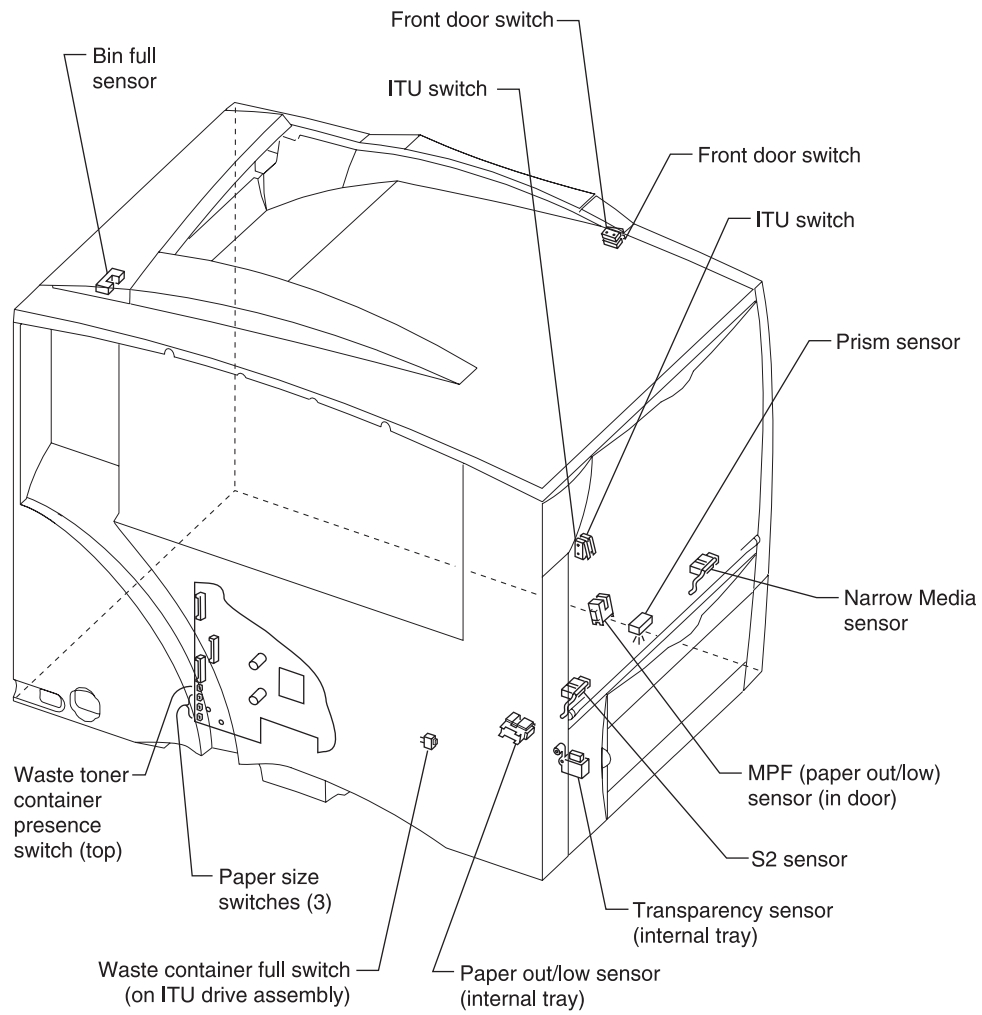

Cartridge contact assembly pin locations

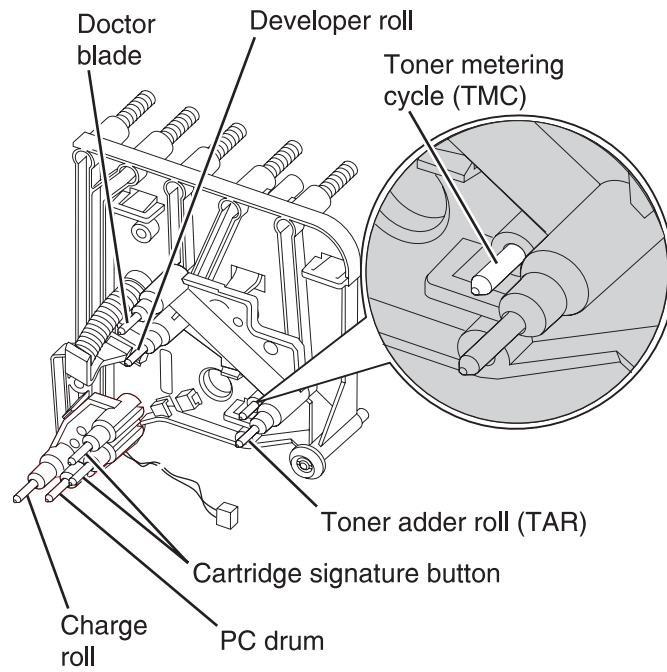

Engine board cabling

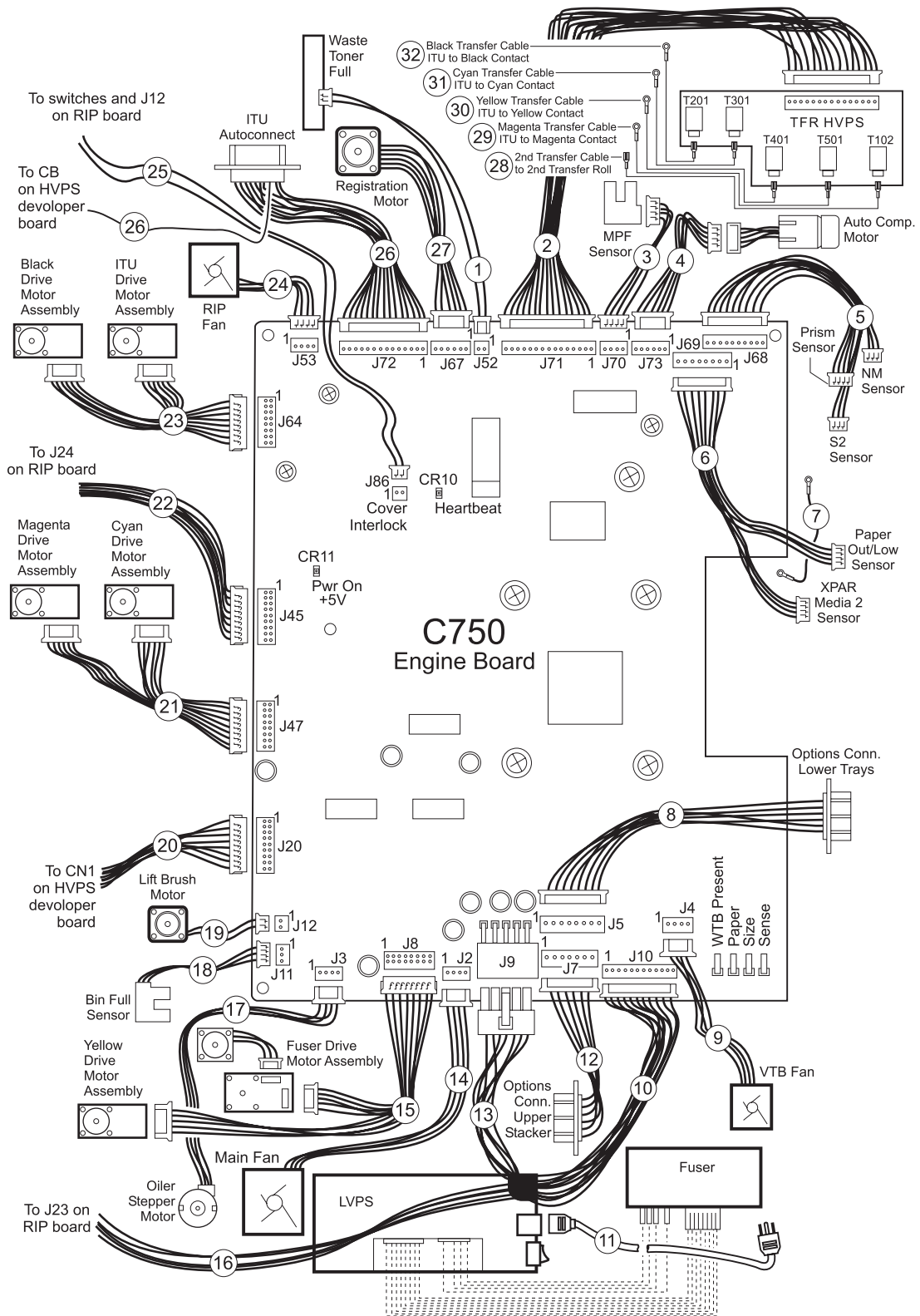

RIP board cabling

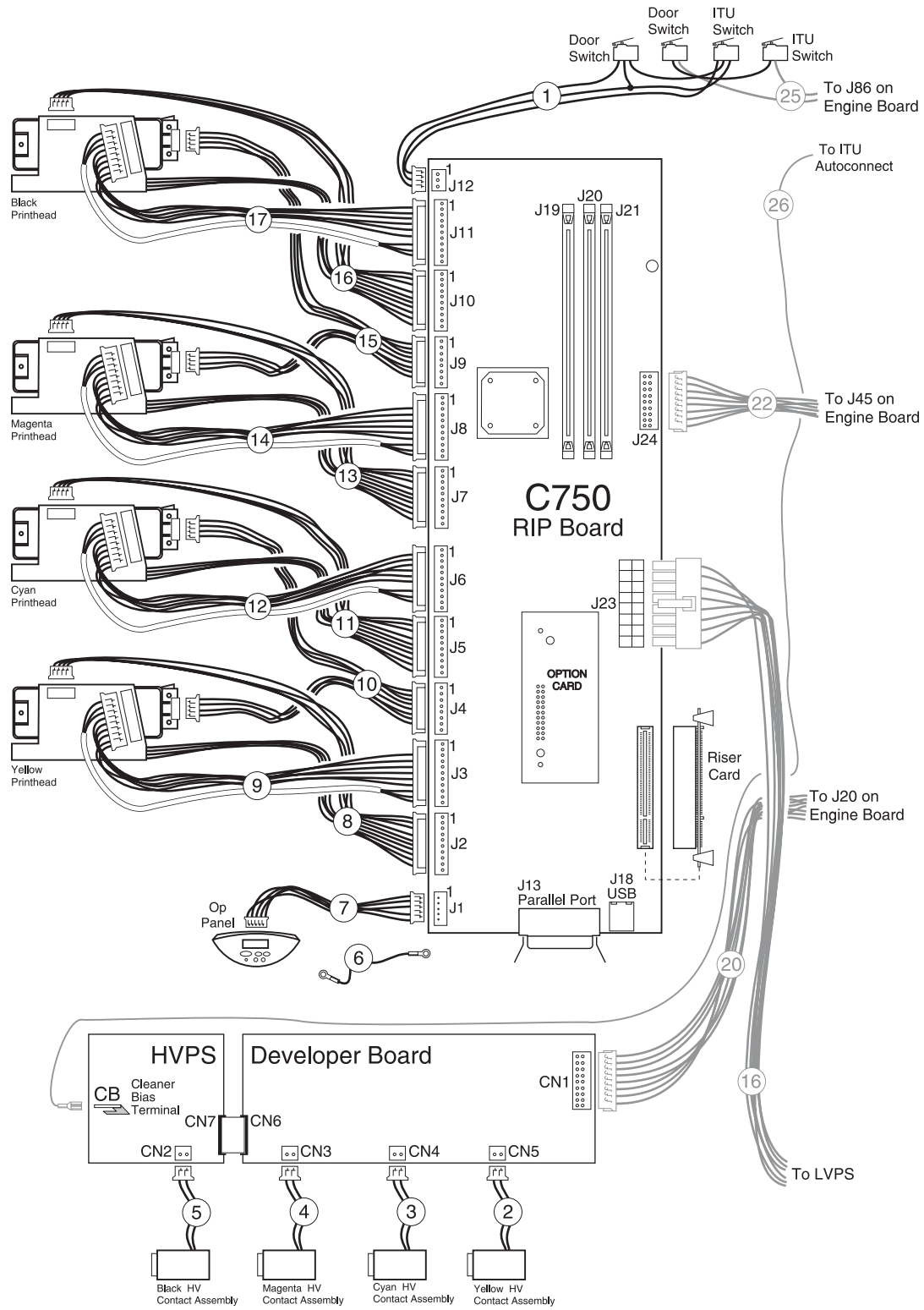

Connectors

Engine board

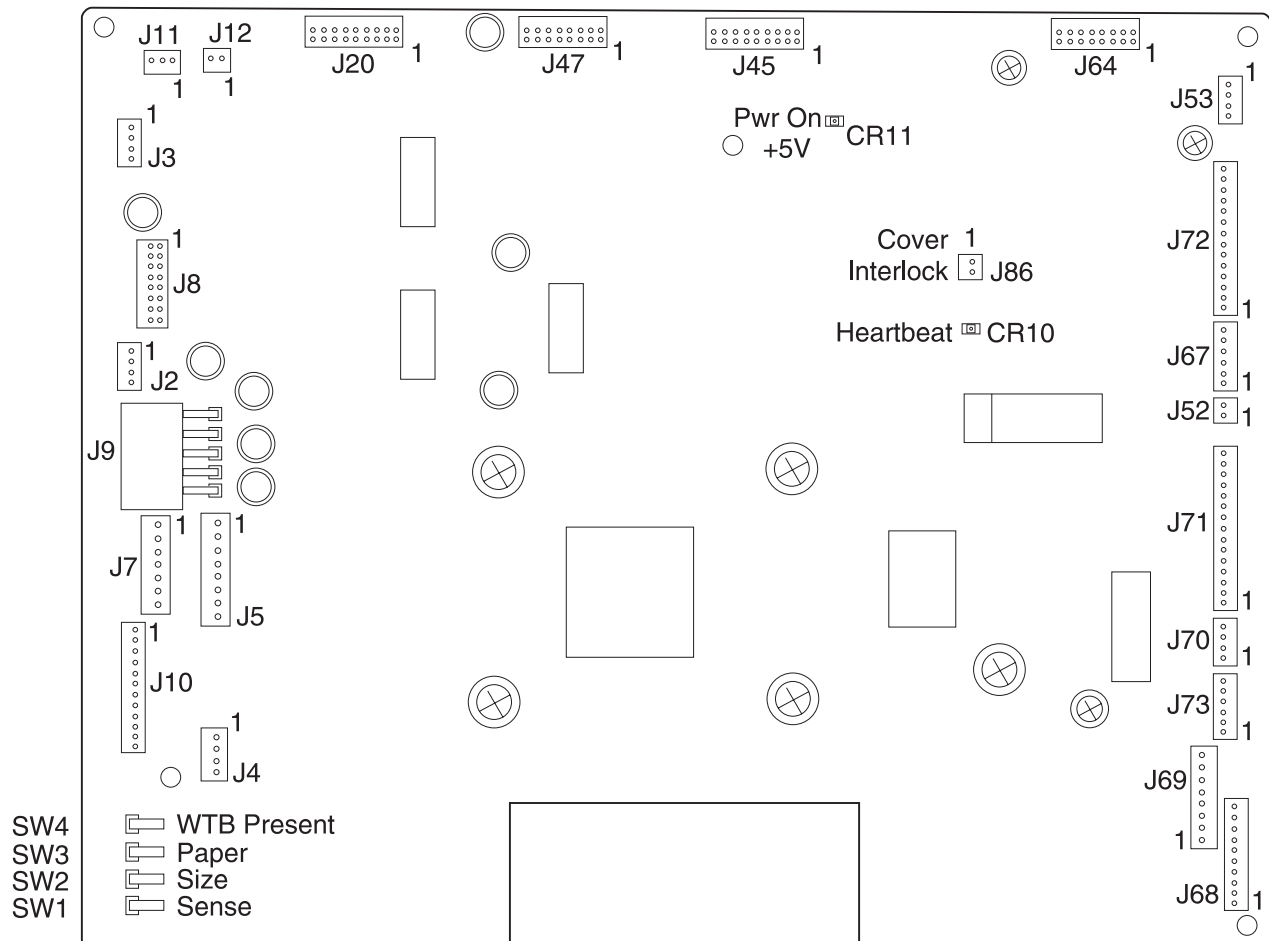

See **“Engine board”** on page 5-7

Connector	Pin no.	Signal
J2 Main Fan	1	FAN1 Stall IN
	2	Ground
	3	FAN1 PWM Out
	4	+24 V dc Left Side
J3 Oiler Stepper Motor	1	Oiler PHA OUT -
	2	Oiler PHA OUT +
	3	Oiler PHB OUT +
	4	Oiler PHB OUT -

See **“Engine board”** on page 5-7

Connector	Pin no.	Signal
J4 VTB Fan	1	FAN2 Stall IN
	2	Ground
	3	FAN2 PWM Out
	4	+24 V dc Left Side
J5 Options Conn. Trays	1	+24 V dc (options)
	2	Ground
	3	RXD1_OPTS_IN
	4	Ground
	5	STAG_ENC
	6	+5 V dc (options)
	7	Ground
	8	-TXD1_OUT
J7 Options Conn. Stacker	1	+24 V dc (options)
	2	Ground
	3	RXD1_OPTS_IN
	4	Ground
	5	+5 V dc (options)
	6	Ground
	7	-TXD1_OUT
J8 Yellow Drive Motor Fuser Drive Motor	1	Y ON OUT
	2	FUSER ON OUT
	3	+5 V dc
	4	+5 V dc
	5	Y DIR OUT
	6	FUSER DIR OUT
	7	+24 V dc
	8	+24 V dc
	9	Ground
	10	Ground
	11	Y CLK OUT
	12	FUSER CLK OUT
	13	Y HALL IN
	14	FUSER HALL IN
	15	Y LOCK IN
	16	FUSER LOCK IN

See **“Engine board”** on page 5-7

Connector	Pin no.	Signal
J9 LVPS	1	+3.3 V dc
	2	+5 V dc
	3	+5 V dc
	4	+24 V dc
	5	+24 V dc
	6	Ground
	7	Ground
	8	Ground
	9	Ground
	10	Ground
J10 Fuser	1	EXIT SENSOR IN
	2	FUSER CAM1 IN
	3	FUSER CAM2 IN
	4	OILER ENC A IN
	5	OILER ENC B IN
	6	HR THERM IN
	7	BR THERM IN
	8	Ground
	9	+5 V dc switched
	10	ZERO Xing IN
	11	HR HEAT ON OUT
	12	BR HEAT ON OUT
J11 Bin Full	1	+5 V dc switched
	2	BIN FULL IN
	3	Ground
J12 BOR (Lift) Motor	1	LIFT PHA OUT -
	2	LIFT PHA OUT +

See **“Engine board”** on page 5-7

Connector	Pin no.	Signal
J20 HVPS - Developer	1	(-CART METER K IN)
	2	K AC B EN OUT
	3	SC K CHIP
	4	KDEV PWM OUT
	5	(-CART METER M IN)
	6	K CHG PWM OUT
	7	SC M CHIP
	8	CMY CHG PWM OUT
	9	(-CART METER C IN)
	10	CMY AC B EN OUT
	11	SC C CHIP
	12	M DEV PWM OUT
	13	(-CART METER Y IN)
	14	C DEV PWM OUT
	15	SC Y CHIP
	16	Y DEV PWM OUT
	17	Ground
	18	+24 V dc switched
J45 RIP Interface	1	I2C DATA RIP
	2	I2C CLK RIP
	3	(-NOTIFY RIP)
	4	Ground
	5	(-VSYNC Y OUT)
	6	FPIRQ RIP
	7	(-VSYNC M OUT)
	8	(-VSYNC C OUT)
	9	Ground
	10	(-VSYNC K OUT)
	11	(-HSYNC Y IN)
	12	(-HSYNC C IN)
	13	(-HSYNC M IN)
	14	(-HSYNC K IN)
	15	(-RIP PRESENT OUT)
	16	Ground
	17	ITU ZONECLK OUT
	18	ITU HOMEZONE OUT

See **“Engine board”** on page 5-7

Connector	Pin no.	Signal
J47 Cyan Cartridge Motor Magenta Cartridge Motor	1	M ON OUT
	2	C ON OUT
	3	+5 V dc
	4	+5 V dc
	5	M DIR OUT
	6	C DIR OUT
	7	+24 V dc M and C
	8	+24 V dc M and C
	9	Ground
	10	Ground
	11	M CLK OUT
	12	C CLK OUT
	13	M HALL IN
	14	C HALL IN
	15	M LOCK IN
	16	C LOCK IN
J52 Waste CLNR Full	1	CLR FULL IN
	2	Ground
J53 RIP Fan	1	FAN3 STALL IN
	2	Ground
	3	FAN3 PWM OUT
	4	+24 V dc Right Side
J64 ITU Drive Motor Black Cartridge Drive Motor	1	K ON OUT
	2	ITU ON OUT
	3	+5 V dc
	4	+5 V dc
	5	K DIR OUT
	6	ITU DIR OUT
	7	+24 V dc ITU and K
	8	+24 V dc ITU and K
	9	Ground
	10	Ground
	11	K CLK OUT
	12	ITU CLK OUT
	13	K HALL IN
	14	ITU HALL IN
	15	K LOCK IN
	16	ITU LOCK IN

See **“Engine board”** on page 5-7

Connector	Pin no.	Signal
J67 Registration Motor	1	+5 V dc switched
	2	STAGING ENC OUT
	3	Ground
	4	Ground
	5	STAGING OUT 2
	6	STAGING OUT 1
J68 S2/NM/Prism Media 1	1	Narrow Media IN
	2	+5 V dc switched
	3	Ground
	4	PPS2 IN
	5	+5 V dc switched
	6	Ground
	7	PRISM LED VOLT
	8	Ground
	9	PRISM SENSOR IN
	10	+5 V dc switched
J69 Paper Out/Low XPAR Media 2	1	+5 V dc switched
	2	PAPER OUT IN
	3	PAPER LOW IN
	4	Ground
	5	LED VCC
	6	Ground
	7	+3.3 V dc
	8	XPAR TRAY 1 IN
J70 MPF Media	1	+5 V dc switched
	2	MPF FEED LOW IN
	3	MPF FEED OUT IN
	4	Ground

See **“Engine board”** on page 5-7

Connector	Pin no.	Signal
J71 HVPS- Transfer	1	ITU TX ENA OUT
	2	ITU TX CUR PWM 0
	3	ITU SERVO INTO
	4	ITU TX PWM OUT
	5	CMY TX ENA OUT
	6	K SERVO INTO
	7	K TX PWM OUT
	8	C SERVO INTO
	9	C TX PWM OUT
	10	Y SERVO INTO
	11	Y TX PWM OUT
	12	M SERVO INTO
	13	M TX PWM OUT
	14	Ground
	15	+24 V dc switched
J72 ITU Autoconnect	1	+5 V dc
	2	ITU DATA
	3	+3.3 V dc
	4	TPS GAIN OUT
	5	ITU TEMP
	6	BELT HOLE 1
	7	Ground
	8	Ground
	9	ITU EEPROM CLK
	10	+24 V dc Right Side
	11	TPS LED ON OUT
	12	TONER PATCH OUT
	13	BELT HOLE 2
	14	+5 V dc switched
J73 Autocompensator Motor	1	+5 V dc SWITCHED
	2	AUTOCOMP ENC IN
	3	Ground
	4	Ground
	5	AUTOCOMP OUT 2
	6	AUTOCOMP OUT 1
J86 Cover Interlock	1	+24 V dc to Cover SW
	2	+24 V dc switched

RIP board

	Connector	Pin no.	Signal
	J1 Operator Panel Connector	1	OP I2CDATA
		2	+5 V dc
		3	OP I2CCIk
		4	Ground
		5	OP I2R-
	J2 Printhead Yellow Connector (Mirror Motor)	1	Ground
		2	HSYNC-/SOS
		3	Ground
		4	+5 V dc Hsync
		5	Ground
		6	mm ref freq
		7	mm lock
		8	mm strt/en
		9	Ground
		10	+24 V dc mir mtr
	J3 Printhead Yellow Connector (Video)	1	N/C
		2	N/C
		3	laser en
		4	Ground
		5	laser adj
		6	Ground
		7	laser PWM
		8	+5 V dc head
		9	Ground
		10	video data -
		11	video data +
	J4 Printhead Yellow/Cyan Connector (EOS)	1	Ground
		2	lexhsync/eos
		3	ALTHERM
		4	+5 V dc EOS card
		5	Ground
		6	lexhsync/eos
		7	ALTHERM
		8	+5 V dc EOS card

	Connector	Pin no.	Signal
	J5 Printhead Cyan Connector (Mirror Motor)	1	Ground
	2	HSYNC-/SOS	
	3	Ground	
	4	+5 V dc Hsync	
	5	Ground	
	6	mm ref freq	
	7	mm lock	
	8	mm strt/en	
	9	Ground	
	10	+24 V dc mir mtr	
	J6 Printhead Cyan Connector (Video)	1	N/C
	2	N/C	
	3	laser en	
	4	Ground	
	5	laser PWR ADJ	
	6	Ground	
	7	laser PWM	
	8	+5 V dc head	
	9	Ground	
	10	video data -	
	11	video data +	
	J7 Printhead Magenta Connector (Mirror Motor)	1	Ground
	2	HSYNC-/SOS	
	3	Ground	
	4	+5 V dc Hsync DC	
	5	Ground	
	6	mm ref freq	
	7	mm lock	
	8	mm strt/en	
	9	Ground	
	10	+24 V dc mir mtr	

	Connector	Pin no.	Signal
	J8 Printhead Magenta Connector (Video)	1	N/C
		2	N/C
		3	laser en
		4	Ground
		5	laser adj
		6	Ground
		7	laser PWM
		8	+5 V dc head
		9	Ground
		10	video data -
		11	video data +x
	J9 Printhead Magenta/Black Connector (EOS)	1	Ground
		2	lexhsync/eos
		3	thermistor
		4	+5 V dc EOS card
		5	Ground
		6	lexhsync/eos
		7	thermistor
		8	+5 V dc EOS card
	J10 Printhead Black Connector (Mirror Motor)	1	Ground
		2	HSYNC-/SOS
		3	Ground
		4	+5 V dc Hsync DC
		5	Ground
		6	mm ref freq
		7	mm lock
		8	mm strt/en
		9	Ground
		10	+24 V dc mir mtr

	Connector	Pin no.	Signal
	J11 Printhead Black Connector (Video)	1	N/C
		2	N/C
		3	laser en
		4	Ground
		5	laser adj
		6	Ground
		7	laser PWM
		8	+5 V dc head
		9	Ground
		10	video data -
		11	video data +
	J12 Cover Open Switch Connector	1	+5 V dc
		2	Ground
		3	V Cor
	J13 Parallel Port Connector		
	J18 USB Port Connector	1	USB +5 V dc
		2	USB D-
		3	USB D+
		4	Ground
		G1 G1	Ground
		G2 G2	Ground
	J19 Option DRAM Socket 2		
	J20 Option DRAM Socket 1		
	J21 Base DRAM Socket		

	Connector	Pin no.	Signal
	J23 Power Connector	1	Ground
	2	Ground	
	3	Ground	
	4	Ground	
	5	Ground	
	6	Ground	
	7	Ground	
	8	Ground	
	9	+3 V dc Sense	
	10	+3.3 V dc	
	11	+3.3 V dc	
	12	+3.3 V dc	
	13	+5 V dc	
	14	+5 V dc	
	15	+5 V dc	
	16	+24 V dc (Fuser)	
	J24 Engine to RIP Connector	1	ITU Zone CLk
	2	ITU Zone HB	
	3	RIPPRES N	
	4	Ground	
	5	HSYN CN M	
	6	HSYN CN K	
	7	HSYN CN Y	
	8	HSYN CN C	
	9	Ground	
	10	VSYN CN K	
	11	VSYN CN M	
	12	VSYN CN C	
13	VSYN CN Y		
14	OP IRQ R		
15	OWL PIO NOTIFY R		
16	Ground		
17	OP I2DATA R		
18	OP I2CLK R		

Transfer high voltage power supply (HVPS)

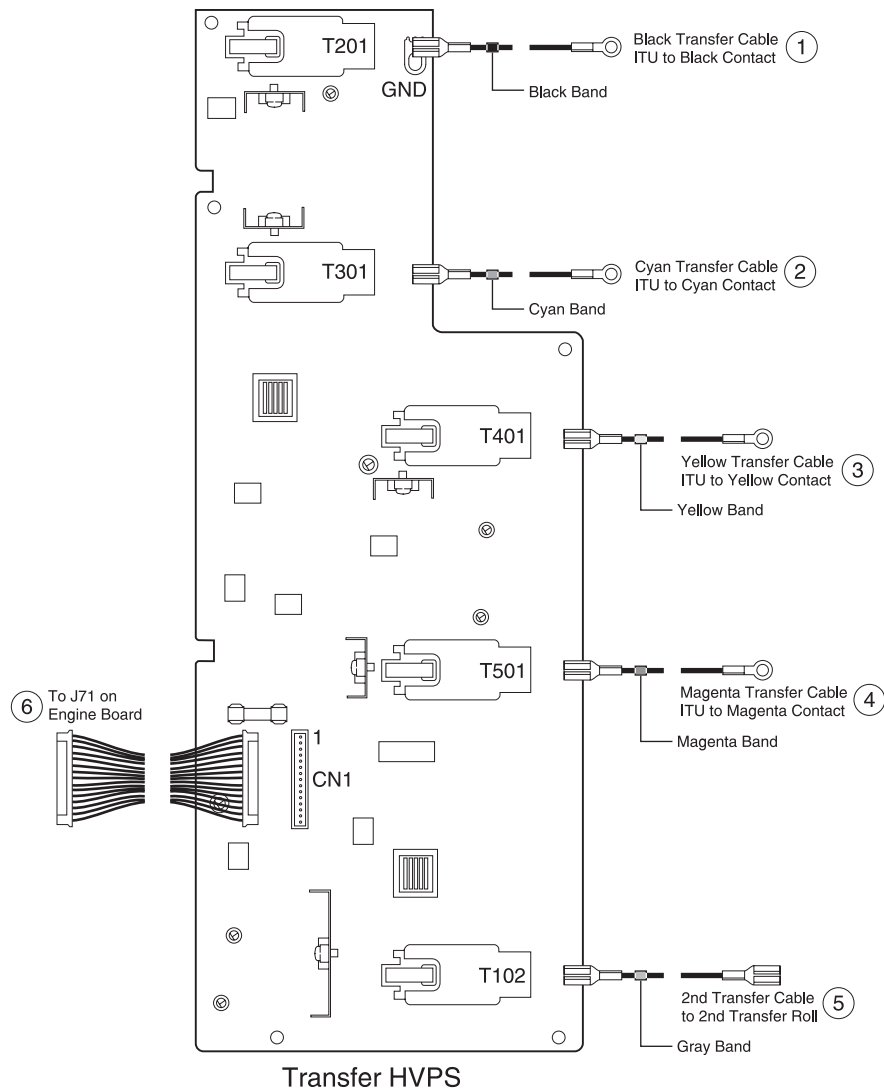

Connector	Pin no	Signal
CN1 HVPS Input Connector	1	+24 V dc
	2	+24 V dc Return
	3	M-Txpwm
	4	M-Srvo out
	5	Y-Txpwm
	6	Y-Srvo out
	7	C-Txpwm
	8	C-Srvo out
	9	K-Txpwm
	10	K-Srvo out
	11	KCYM-Txenable

Connector	Pin no	Signal
CN1 HVPS Input Connector (continued)	12	I-Txpwm
	13	I-Srvo out
	14	I-Txcurpwm
	15	I-Txenable
T102 Transformer HV Terminal I (ITU)	1	HV Transformer output to 2nd Transfer Roll Cable
T201 Transformer HV Terminal K Black	1	HV Transformer Output Terminal to Black Transfer Cable
T301 Transformer HV Terminal C Cyan	1	HV Transformer Output Terminal to Cyan Transfer Cable
T401 Transformer HV Terminal Y Yellow	1	HV Transformer Output Terminal to Yellow Transfer Cable
T501 Transformer HV Terminal M Magenta	1	HV Transformer Output Terminal to Magenta Transfer Cable

Developer high voltage power supply (HVPS) board

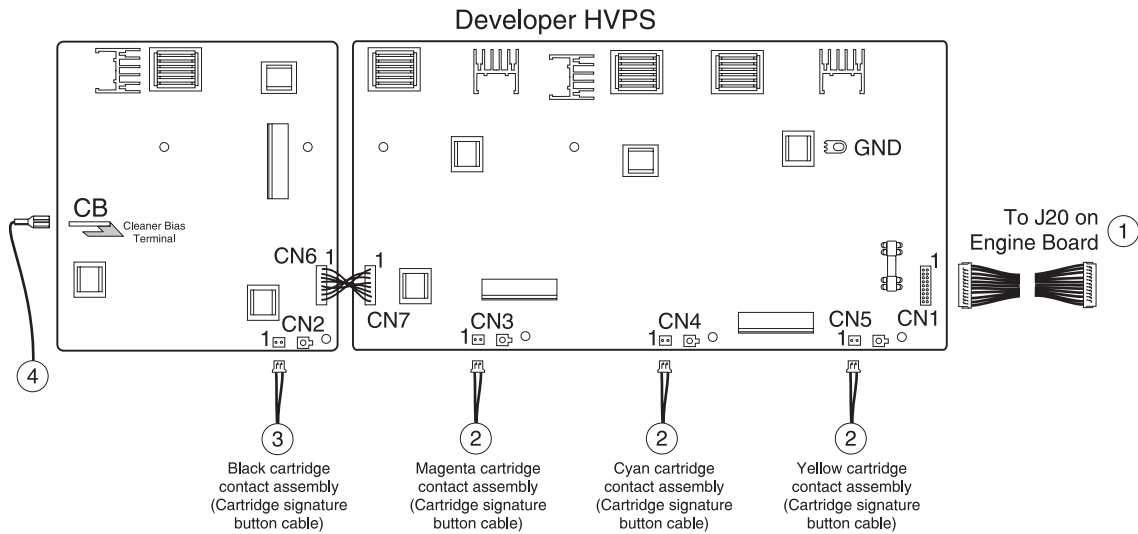

Connector	Pin no	Signal
CN1 Developer HVPS Input	1	Ground +24 V dc return
	2	+24 V dc
	3	Y-Ctsense
	4	Y-Devpwm
	5	Y-TnrSense
	6	C-Devpwm
	7	C-CtSense
	8	M-Devpwm
	9	C-TnrSense
	10	CYM-Acenable
	11	M-CtSense
	12	CYM-Chgpwm

Connector	Pin no	Signal
CN1 Developer HVPS Input (continued)	13	M-TnrSense
	14	K-Chgpwm
	15	K-CtSense
	16	K-Devpwm
	17	K-TnrSense
	18	K-Acenable
CN2 Cartridge Signature Button - Black	1	K-CtSense
	2	K-TnrSense (Gnd Return)
CN3 Cartridge Signature Button - Magenta	1	M-CtSense
	2	M-TnrSense (Gnd Return)
CN4 Cartridge Signature Button - Cyan	1	C-CtSense
	2	C-TnrSense (Gnd Return)
CN5 Cartridge Signature Button - Yellow	1	Y-CtSense
	2	Y-TnrSense (Gnd Return)
CB Terminal		Cleaner Bias Terminal

Low voltage power supply (LVPS)

Engine and RIP board cable connectors

	Connector	Pin no.	Signal
<p>Diagram showing two LVPS connectors. The left connector is labeled 'LVPS to Engine Board To (J9)' with pins 5, 1, 10, and 6. The right connector is labeled 'LVPS to RIP Board To (J23)' with pins 1, 8, 9, and 16.</p>	RIP Board Power	1	Ground Return +3.3 V dc rtn
		2	Ground Return +3.3 V dc rtn
		3	Ground Return +3.3 V dc rtn
		4	Ground Return +3.3 V dc rtn
		5	Ground Return +5 V dc rtn
		6	Ground Return +5 V dc rtn
		7	Ground Return +5 V dc rtn
		8	Ground Return +24 V dc rtn
		9	+3.3 V dc Sense
		10	+3.3 V dc
		11	+3.3 V dc
		12	+3.3 V dc
		13	+5 V dc
		14	+5 V dc
		15	+5 V dc
		16	+24 V dc
	Engine Board Power	1	+3.3 V dc
		2	+5 V dc
		3	+5 V dc
		4	+24 V dc
5		+24 V dc	
6		Ground	
7		Ground	
8		Ground	
9		Ground	
10		Ground	

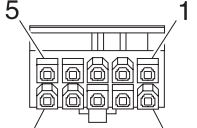
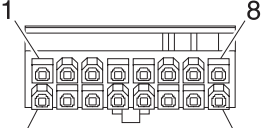
	Connector	Pin no.	Signal
 <p data-bbox="300 472 462 577">LVPS to Engine Board To (J9)</p>  <p data-bbox="625 472 738 577">LVPS to RIP Board To (J23)</p>	Engine board cable (LVPS to J10 fuser connector)	1	EXITSENSORIN
		2	BURCam1
		3	N/C
		4	WebEncoderA
		5	WebEncoderB
		6	HRThermistor
		7	BURThermistor
		8	Ground
		9	+5 V dc switched
		10	ZEROXINGIN
		11	Heat On #1 (HR)
		12	Heat On #2x (BUR)

Low voltage power supply (LVPS)

LVPS to fuser connectors (on LVPS)

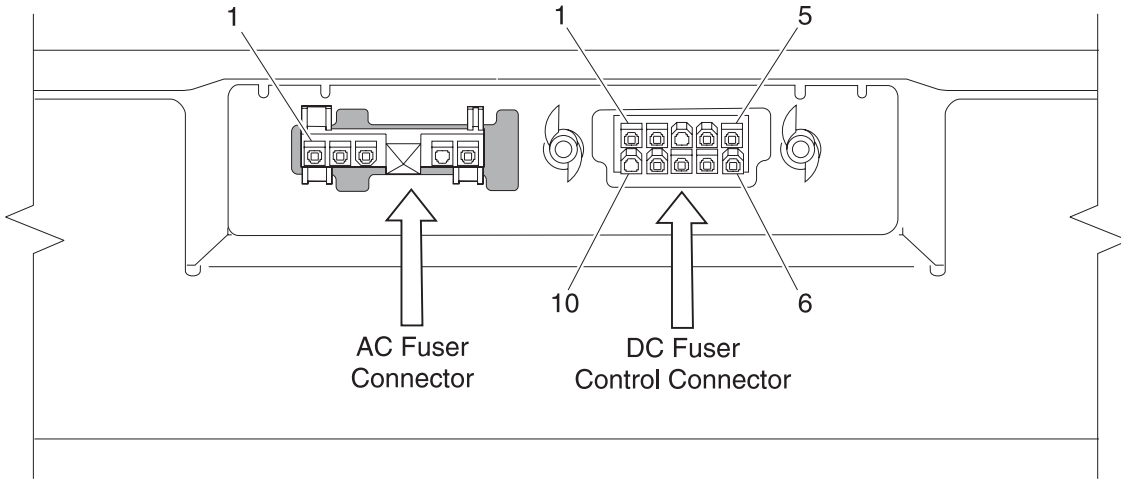

Fuser to LVPS connectors (on fuser)

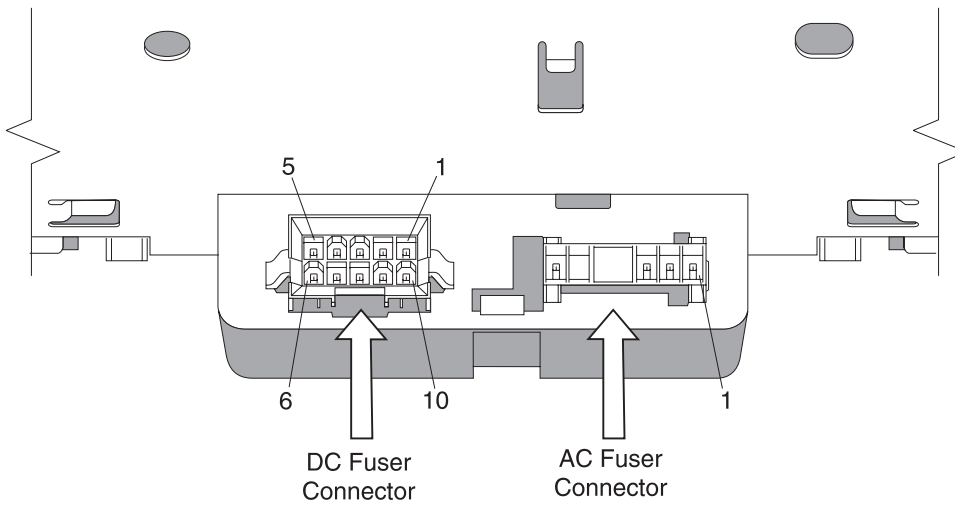

Fuser connectors

Connector	Pin no.	Signal
LVPS AC Fuser Connector	1	AC Load #1
	2	AC Common
	3	Ground
	4	N/C
	5	AC Load #2x
LVPS DC Fuser Control Connector	1	FusExitSen
	2	BURCam1
	3	N/C
	4	WebEncoderA
	5	WebEncoderB
	6	HRThermistor
	7	BURThermistor
	8	Return - Analog Ground
	9	+5 V dc switched
	10	N/C

High-capacity input tray (2000-sheet HCIT) board

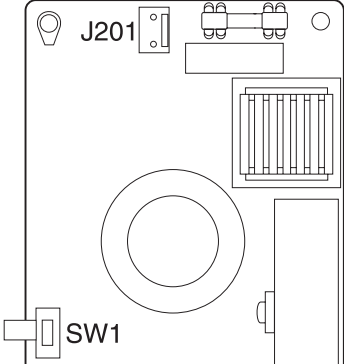
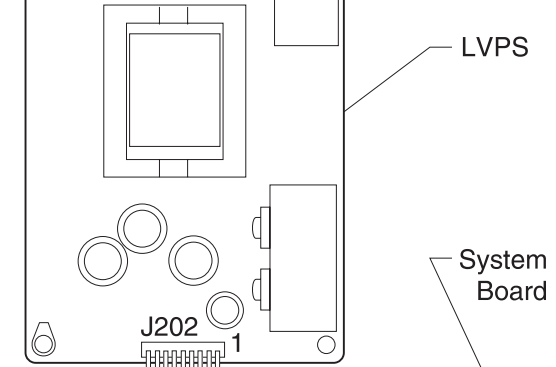
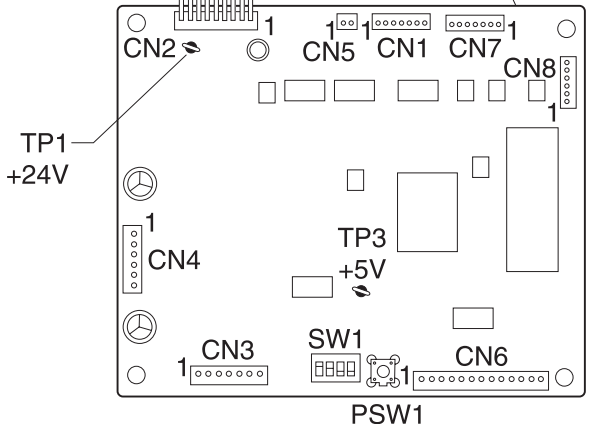
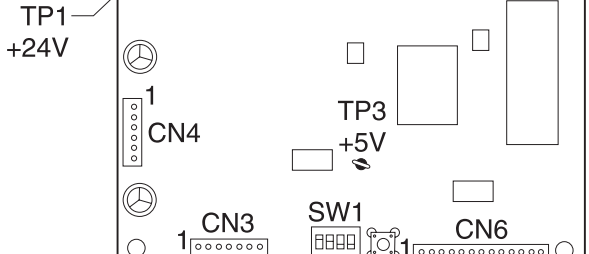
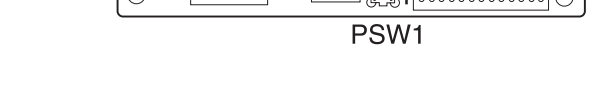
	Connector	Pin no.	Signal
	CN1 I/F	1	Send
		2	PRI RXD
		3	PGND
		4	PERON
		5	SGND
		6	PRI TXD
	CN2 LVPS	1	Poweron
		2	+5 V dc
		3	SGND
		4	PGND
		5	PGND
		6	PGND
		7	+24 V dc
		8	+24 V dc
		9	+24 V dc
	CN3 REG Motor	1	+24 V dc
		2	+24 V dc
		3	REG A
		4	REG A
		5	REG B
		6	REG B
		7	No Connection
	CN4 PICK Motor	1	+24 V dc
		2	+24 V dc
		3	PICK A
		4	*PICK A
		5	PICK B
		6	*PICK B
	CN5 LIFT Motor	1	+24 V dc
		2	LHOT

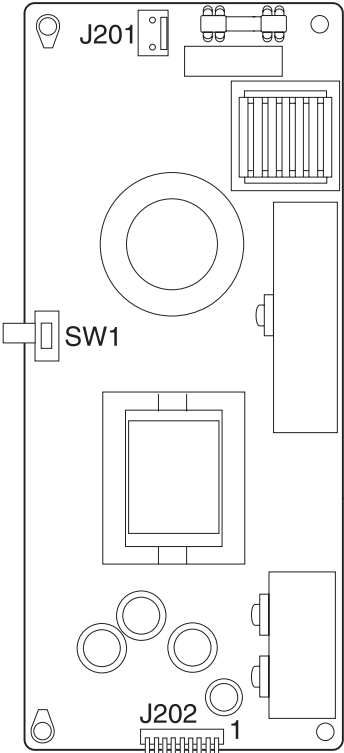
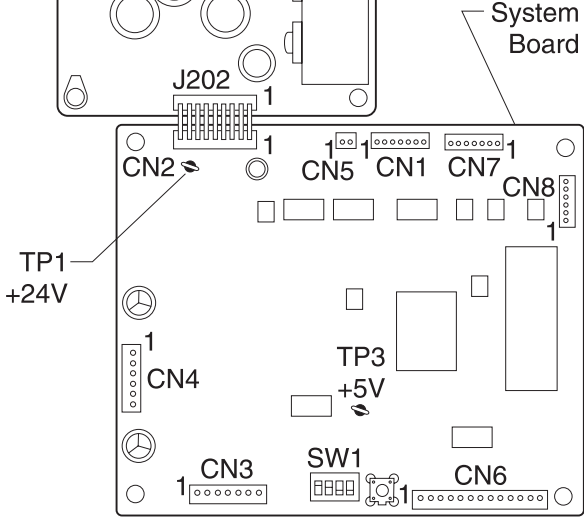
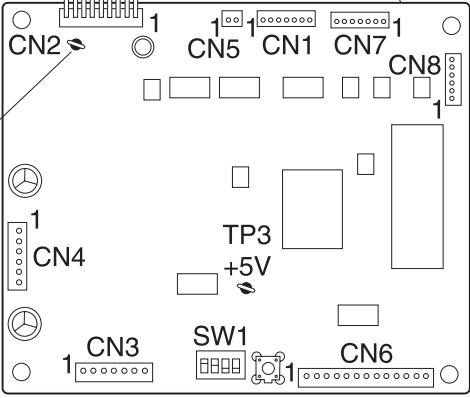
	Connector	Pin no.	Signal
 <p>Diagram of LVPS board showing J201 connector and SW1 switch.</p>	<p>CN6 Sensors Side Door/Level/ Empty/ Registration Home/Pick Home</p>	1	+5 V dc
		2	GND
		3	SIDE
		4	+5 V dc
		5	GND
		6	LEVEL
		7	+5 V dc
		8	GND
		9	EMPTY
		10	+5 V dc
		11	GND
		12	RHOME
		13	+5 V dc
		14	GND
		15	PHOME
 <p>Diagram of System Board showing various connectors (CN1-CN8), switches (SW1, PSW1), and test points (TP1, TP3).</p>	<p>CN7 Size Sensors/Near Empty</p>	1	+5 V dc
		2	GND
		3	SIZE 0
		4	+5 V dc
		5	GND
		6	SIZE 1
		7	+5 V dc
		8	GND
		9	SIZE 2
		10	+5 V dc
		11	GND
		12	NE EMP
 <p>Diagram of System Board showing CN8 connector and PSW1 switch.</p>	<p>CN8 S1(Pick Sensor) S2(Registration Sensor)</p>	1	+5 V dc
		2	S2
		3	GND
		4	+5 V dc
		5	S1
		6	GND

High-capacity output finisher (HCOF)

HCOF LVPS board

Connector	Pin No	Signal
CN2 LVPS Out	1	+24 V dc
	2	+24 V dc
	3	+24 V dc
	4	+24 V dc
	5	Ground
	6	Ground
	7	Ground
	8	Ground
CN1	1	AC In from Relay
	2	Not Used
	3	Not Used
	4	Not Used
	5	AC In from Relay

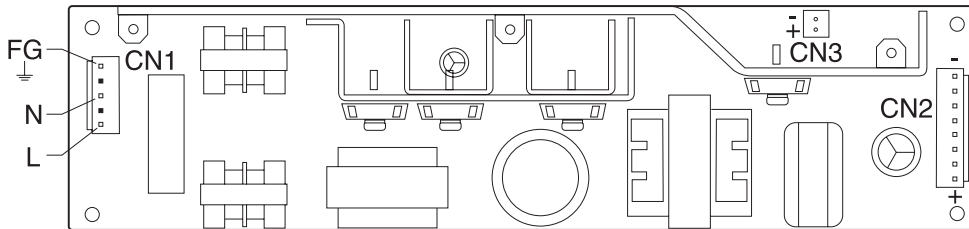

HCOF SUB LVPS relay board

	Connector	Pin no	Signal
	CN1 AC Input	1	AC In
		2	Not used
		3	Not used
		4	Not used
		5	AC In
	CN2 LVPS	1	AC Out to LVPS
		2	Not used
		3	AC Out to LVPS
	CN3 Relay Board +5 V dc Switched	1	+5 V dc
		2	Ground

HCOF system board

See “HCOF system board” on page 5-32

Connector	Pin no	Signal
CN1 Drop Solenoid	1	SOL+
	2	SOL-
CN2 Stapler Assembly	1	MTR-
	2	MTR-
	3	N/C
	4	MTR+
	5	MTR+
	6	N/C
	7	No Cartridge
	8	Low Staple
	9	Home Position
	10	Unit Check
	11	Ground
	12	+5 V dc
CN3 Jogger Motor/ Bundle Motor	1	Jog A
	2	Jog *A
	3	Jog B
	4	Jog *B
	5	Bun A
	6	Bun *A
	7	Bun B
	8	Bun *B
CN4 Stapler Sensor	1	+5 V dc
	2	Jog Home Pos Sensor
	3	Ground
	4	+5 V dc
	5	Bundle Belt Home Pos Sensor
	6	Ground
CN5 Chad Box Full	1	+5 V dc
	2	Chad Box Sensor
	3	Ground

See **“HCOF system board”** on page 5-32

Connector	Pin no	Signal
CN6 Tray Sensors Tray Limit/Near Full/Offset Position	1	Tray Limit SW
	2	Ground
	3	+5 V dc
	4	Tray Near Full Sensor
	5	Ground
	6	+5 V dc
	7	Tray Offset Posit Sensor
	8	Ground
CN7 Tray Motor	1	MTR +
	2	MTR -
CN8 Tray Sensors Exit Timing/Paper Surface Upper/Paper Surface Lower	1	+5 V dc
	2	Exit Timing Sensor
	3	Ground
	4	+5 V dc
	5	Paper Surface Upper Sensor
	6	Ground
	7	+5 V dc
	8	Paper Surface Lower Sensor
	9	Ground
CN9 Feed	1	A+
	2	A-
	3	B+
	4	B-
CN10 Inverter Jam	1	+SOL
	2	-SOL
	3	+5 V dc
	4	Inverter Jam Sensor
	5	Ground
CN11 Door Switch	1	Switch +
	2	Switch -
CN12 Tray Lift	1	MTR +
	2	MTR -
CN13 Feed Motor	1	A+
	2	A-
	3	B+
	4	B-
	5	N/C

See **“HCOF system board”** on page 5-32

Connector	Pin no	Signal
CN14 Power	1	+24 V dc
	2	+24 V dc
	3	P-Ground
	4	P-Ground
CN15 Feed Motor	1	A+
	2	A-
	3	B+
	4	B-
	5	N/C
CN16 Punch	1	+5 V dc
	2	Drop Timing Sensor
	3	Ground
	4	+5 V dc
	5	Punch Home Sensor
	6	Ground
	7	+5 V dc
	8	Punch Timing A Sensor
	9	Ground
	10	+5 V dc
	11	Punch Timing B Sensor
	12	Ground
CN17 Feed	1	SOL+
	2	SOL -
CN18 Communications	1	TxD
	2	SG
	3	RxD
	4	SG
	5	FG
CN19 Joint	1	Switch - PTR Joint
	2	N/C
	3	Ground
CN20 CPU Prog	1	
	20	

HCOF system board

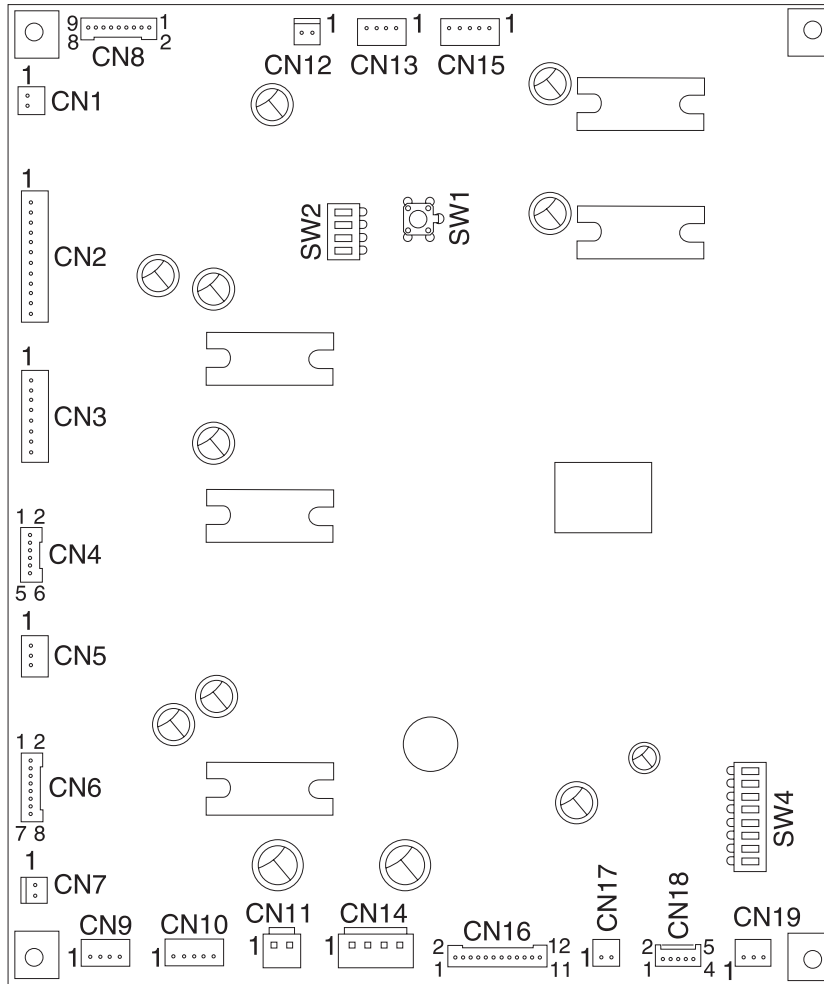

6. Preventive maintenance

This chapter describes procedures for printer preventive maintenance. Follow these recommendations to help prevent problems and maintain optimum performance.

Safety inspection guide

The purpose of this inspection guide is to aid you in identifying unsafe conditions.

If any unsafe conditions exist, find out how serious the hazard could be and if you can continue before you correct the hazard.

Check the following items:

- Damaged, missing, or altered parts, especially in the area of the On/Off switch and the power supply
- Damaged, missing, or altered covers, especially in the area of the top cover and the power supply cover
- Possible safety exposure from any non-Lexmark attachments

Lubrication specifications

Lubricate only when parts are replaced or as needed, not on a scheduled basis. Use of lubricants other than those specified can cause premature failure. Some unauthorized lubricants may chemically attack polycarbonate parts. Use IBM no. 10 oil, P/N 1280443 (Approved equivalents: Mobil DTE27, Shell Tellus 100, Fuchs Renolin MR30), IBM no. 23 grease (Approved equivalent Shell Darina 1), and grease, P/N 99A0394 to lubricate appropriate areas. Use Nyogel type 774 to lubricate the Fuser Drive Assembly and Nyogel 744 to lubricate the ITU and Cartridge Drive assemblies.

Lubrication for replacement motors

The motor drive FRUs contain the proper lubricant in the FRU. Only use the lubricant included.

Fuser drive assembly

Before installing the new Fuser Drive Assembly:

1. Apply a thin coating of Nyogel type 774 grease to the points identified (A) from the supplied packet.

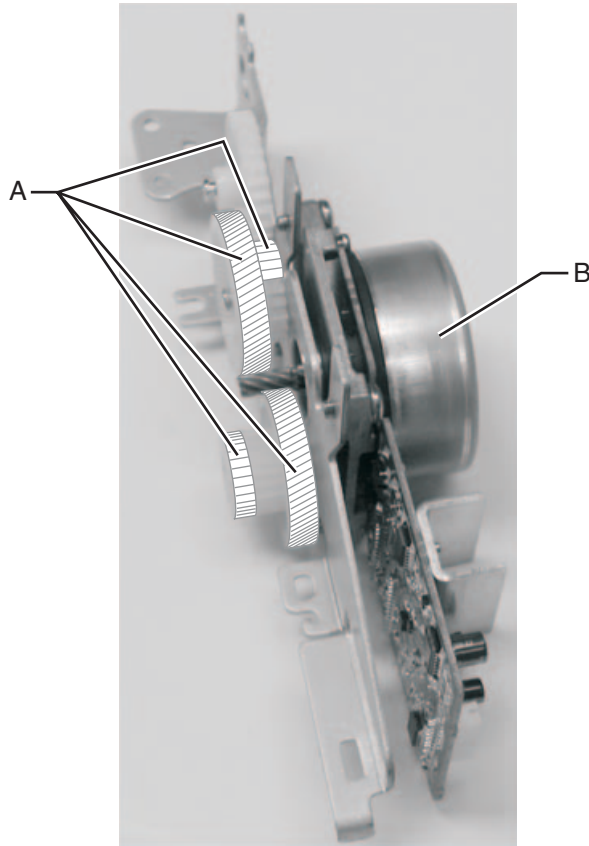

2. Rotate the motor housing (B) to distribute evenly.

Cartridge drive assembly

1. Apply a thin coating of Nyogel type 744 grease to the points identified (A) from the supplied packet.

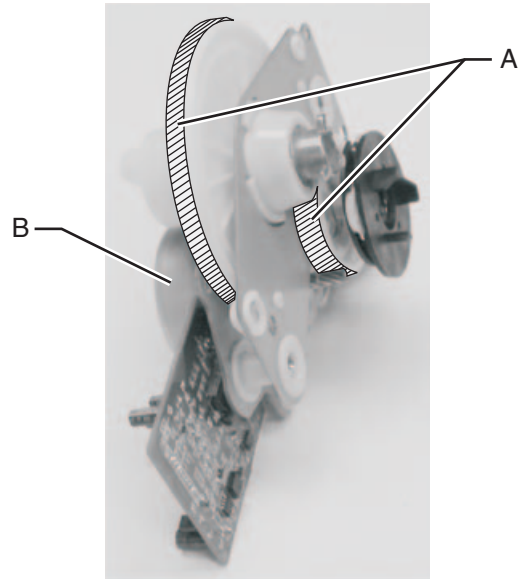

2. Rotate the motor housing (B) to distribute evenly.

ITU drive assembly

1. Apply a thin coating of Nyogel type 744 grease to the points identified (A) from the supplied packet.

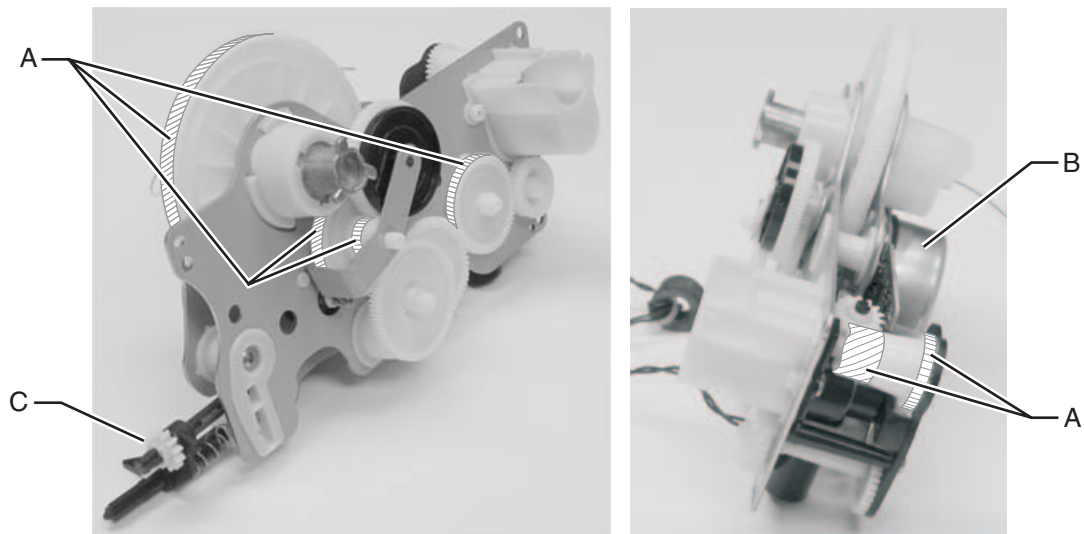

Note: Do not lubricate Gear 58 (C).

2. Rotate the motor housing (B) to distribute evenly.

Scheduled maintenance

The operator panel displays 80 Fuser Maintenance and 83 ITU Maintenance for scheduled maintenance.

80 Fuser Maintenance is displayed at each 150K copies when the fuser assembly needs to be replaced to maintain the print quality and reliability of the printer. The parts are available as a maintenance kit with the following part numbers:

Standard fusers

- 12G6496, Maintenance kit 115V
- 12G6497, Maintenance kit 220V
- 12G6498, Maintenance kit 100V

Web oiler fusers

- 12G6514, 110 V web oiler fuser
- 12G6515, 220 V web oiler fuser
- 12G6502, 100 V web oiler fuser

After replacing the kit, the fuser maintenance count must be reset to zero to clear the maintenance message. See **“Reset Fuser Cnt” on page 3-8**.

83 ITU Maintenance is displayed at each 105K copies when the ITU Assembly needs to be replaced to maintain the print quality and reliability of the printer. There are two assemblies, ITU assembly and Second Transfer Roll, in a maintenance kit. Both should be replaced at the same time. The parts are available as a maintenance kit with P/N 12G6304, ITU Maintenance Kit.

84 Oiler Nearly Exhausted is displayed at each 100K copies when the Web Oiler Assembly is nearly exhausted. Go to **“Web oiler assembly” on page 7-11** for part number.

7. Parts catalog

How to use this parts catalog

- **SIMILAR ASSEMBLIES:** If two assemblies contain a majority of identical parts, they are shown on the same list. Common parts are shown by one index number. Parts peculiar to one or the other of the assemblies are listed separately and identified by description.
- **NS:** (Not Shown) in the Asm–Index column indicates that the part is procurable but is not pictured in the illustration.
- **PP:** (Parts Packet) in the Description column indicates the part is contained in a parts packet.

The Lexmark C750 (5060-00x) laser printer is available in two models:

5060-001
5060-002

The parts catalog uses these designations to identify model specific FRUs.

Assembly 1: Covers

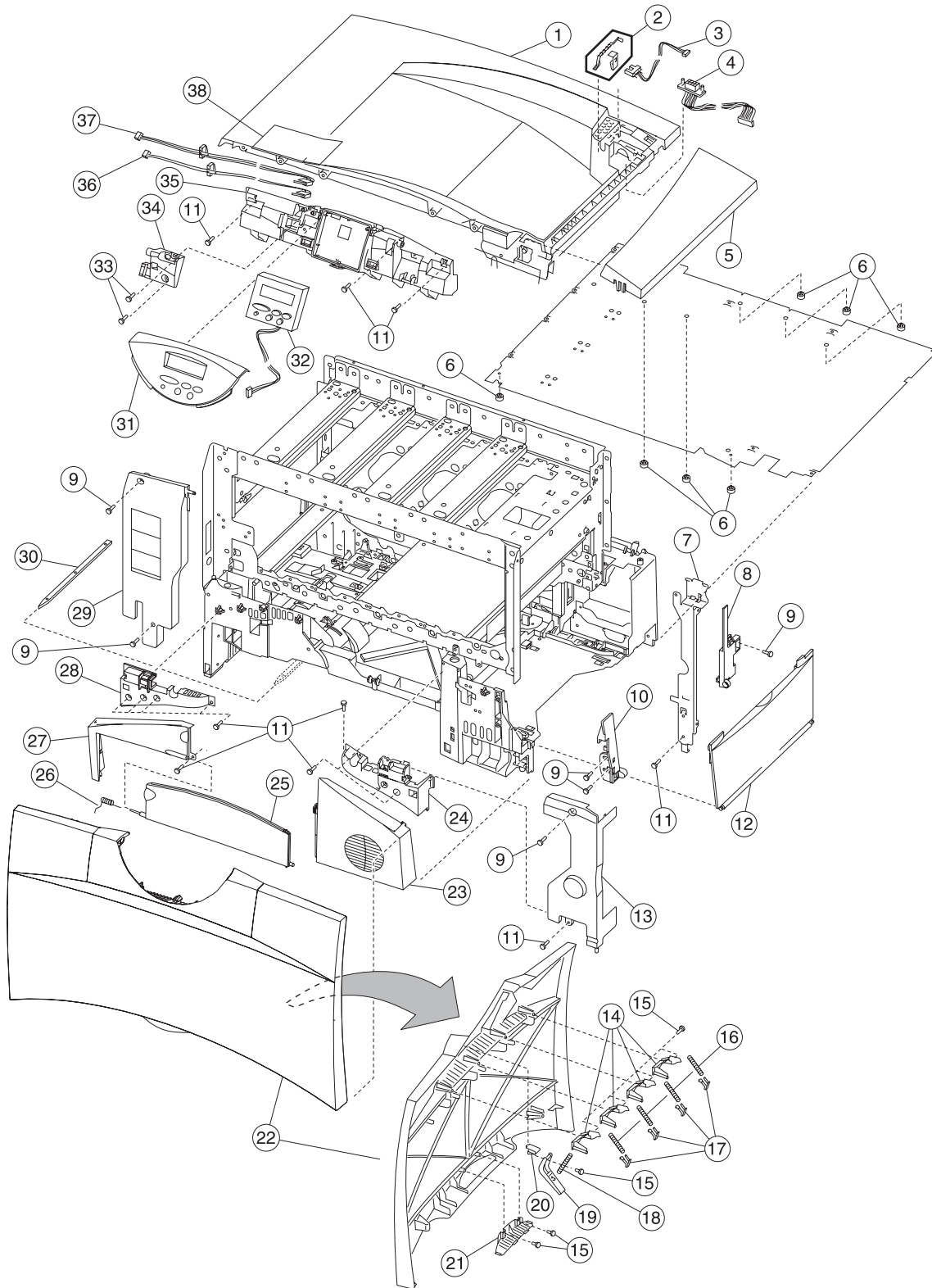

Assembly 1: Covers

Asm- Index	Part number	Units	Description
1-1	12G6410	1	Top cover assembly
2	12G6507	1	250 output flag, includes flag retainer
3	12G6506	1	Bin full sensor
4	12G6319	1	Cable, options - stacker
5	12G6409	1	Redrive cap cover assembly
6	12G6380	7	Machine pad
7	12G6389	1	Top front support bracket
8	12G6396	6	Right rear cover
9		6	Screw, PP 12G6530
10	12G6393	1	Right front cover
11		18	Screw, PP 12G6309
12	12G6356	1	Lower right door assembly
13	12G6405	1	Front right light shield cover
14	56P2216	4	Shield, door spring
15		7	Screw, PP 56P2220
16	12G6376	4	Spring, rear hold down
17	12G6347	1	Front hold down bellcrank
18	56P2246	1	Detent spring
19	56P2218	1	Detent, front access door
20	56P2219	1	Housing, front access door
21	56P2217	1	Handle, front access door
22	12G6357	1	Front cover assembly
23	12G6394	1	Front lower right cover
24	12G6411	1	Front right handle cover assembly
25	12G6391	1	Paper path access door
26	12G6403	1	Spring, paper path access door
27	12G6388	1	Front lower left cover
28	12G6412	1	Front left handle cover assembly
29	12G6404	1	Left front light shield cover
30	56P1277	1	Paper tray guide
31	12G6402	1	Operator panel bezel with logos
32	12G6344	1	Operator panel assembly, low volt
32	12G6345	1	Operator panel assembly, high volt
33		2	Screw, PP 12G6532
34	12G6399	1	Front upper pivot cover
35	12G6397	1	Front access door support
36	12G6504	1	Cable, HVPS interlock/cover open (2-wire)
37	12G6503	1	Cable, printhead interlock/cover open (3-wire)
38	56P2489	1	Label, top paper jam

Assembly 1.1: Covers

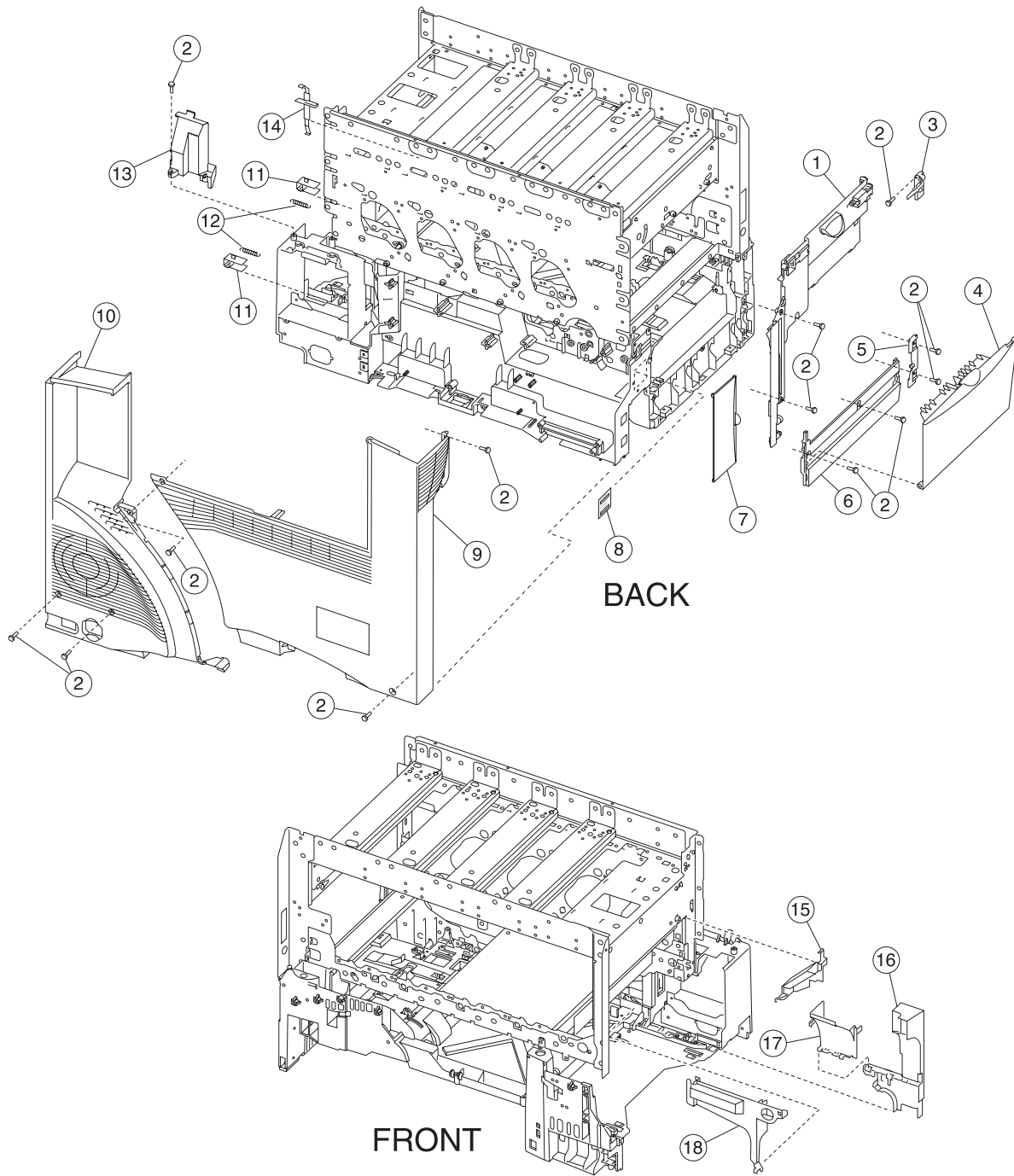

Assembly 1.1: Covers

Asm- Index	Part number	Units	Description
1.1-1	12G6408	1	Left upper cover assembly
2		14	Screw, PP 12G6309
3	12G6392	1	Left upper pivot cover
4	12G6485	1	Lower access jam door assembly
5	12G6398	1	Left lower pivot cover
6	12G6395	1	Cover, left lower
7	12G6400	1	Waste container door
8	12G6339	1	Blank, TLI/SN label
9	12G6390	1	Rear cover
10	12G6401	1	Rear fan cover
11	12G6383	2	Fuser latch slide
12	12G6384	2	Fuser latch slide spring
13	12G6340	1	Fuser top duct
14	12G6386	1	Duplex actuator arm
15	12G6360	1	Fuser wall duct
16	12G6358	1	Fuser bottom duct
17	56P2290	1	Fuser left duct
18	56P2291	1	Redrive belt cover duct
NS	12G6510	6	Cable tie (6 in pack)

Assembly 2: Cartridge mounting

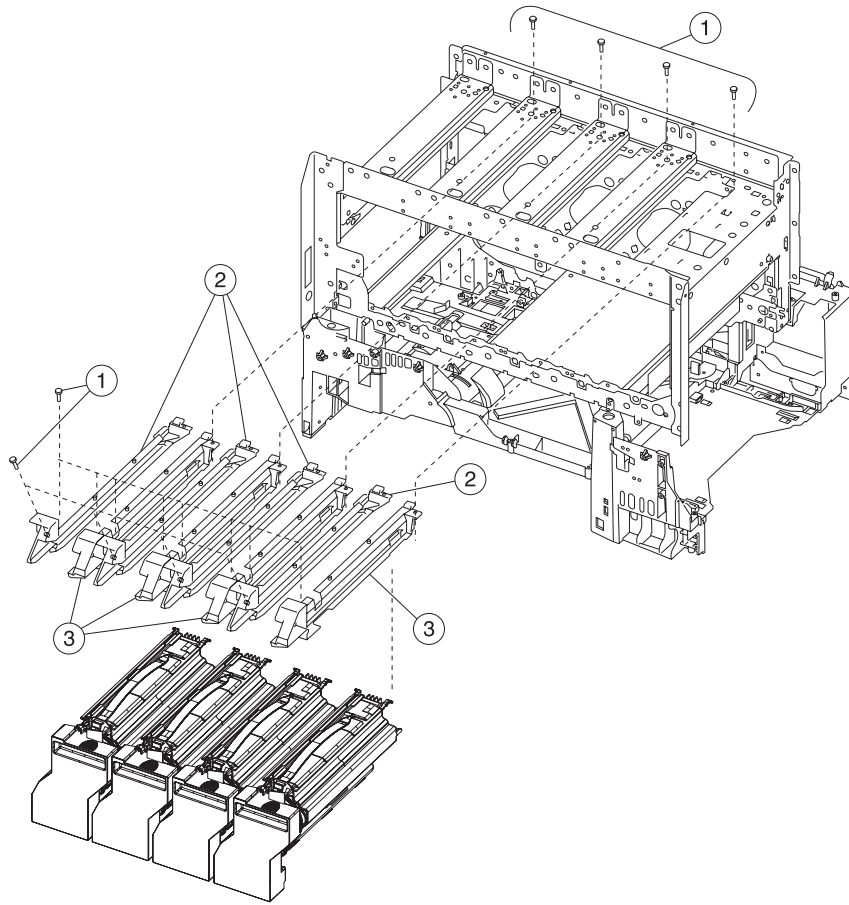

Assembly 2: Cartridge mounting

Asm- Index	Part number	Units	Description
2-1		16	Screw, PP 12G6532
2	12G6535	4	Guide assembly, left side
3	12G6536	4	Guide assembly, right side

5060-00x

Assembly 3: Fuser

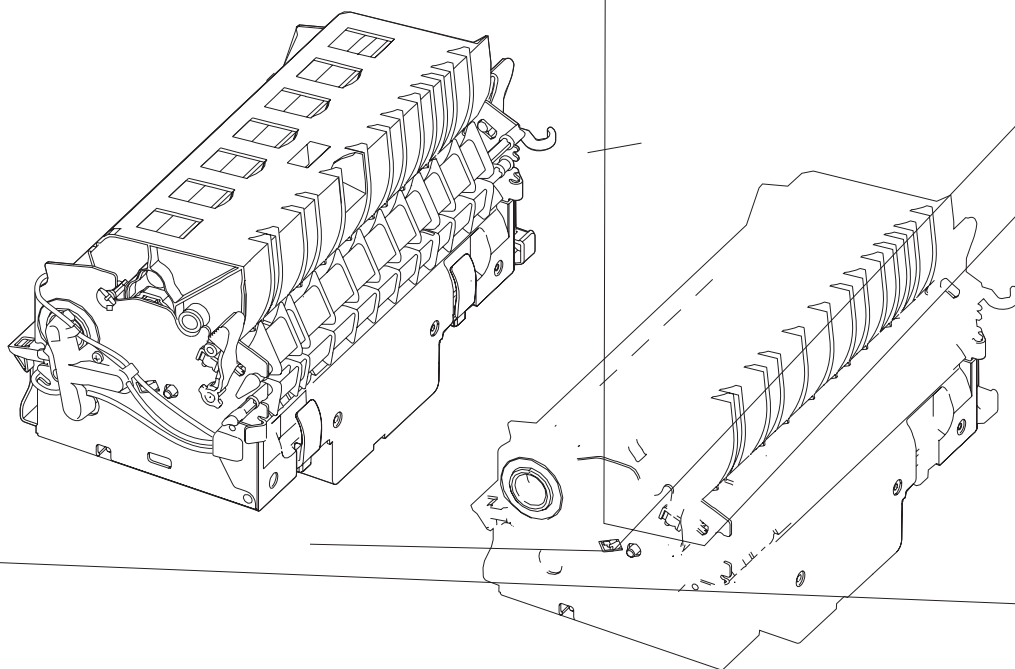

Assembly 3: Fuser

Asm- Index	Part Number	Units	Description
3-1	12G6495	1	Fuser assembly 100V 500W
1	12G6301	1	Fuser assembly 115V 500W
1	12G6302	1	Fuser assembly 220V 500W
2	12G6516	1	Fuser lamp, 100V 500W hot roll
2	12G6337	1	Fuser lamp, 115V 500W hot roll
2	12G6341	1	Fuser lamp, 220V 500W hot roll
3	12G6517		Fuser lamp, 100V 400W backup roll
3	12G6338	1	Fuser lamp, 115V 400W backup roll
3	12G6342	1	Fuser lamp, 220V 400W backup roll

Assembly 3.1: Fuser (web oiler)

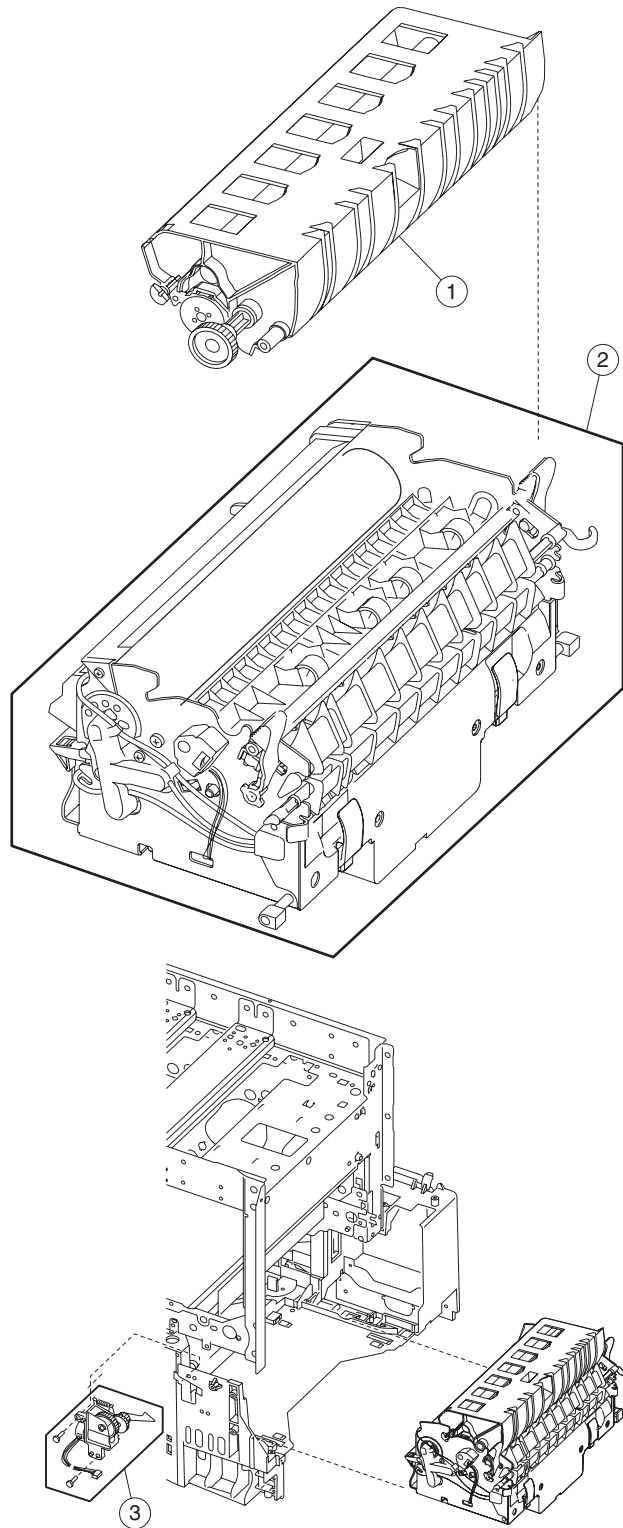

Assembly 3.1: Fuser

Asm- Index	Part Number	Units	Description
3.1-1	12G6545	1	Web oiler assembly
2	12G6495	1	Fuser assembly, web oiler 100V 500W
2	12G6514	1	Fuser assembly, web oiler 115V 500W
2	12G6515	1	Fuser assembly, web oiler 220V 500W
3	12G6543	1	Web oiler index drive assembly

Assembly 4: Fuser drive

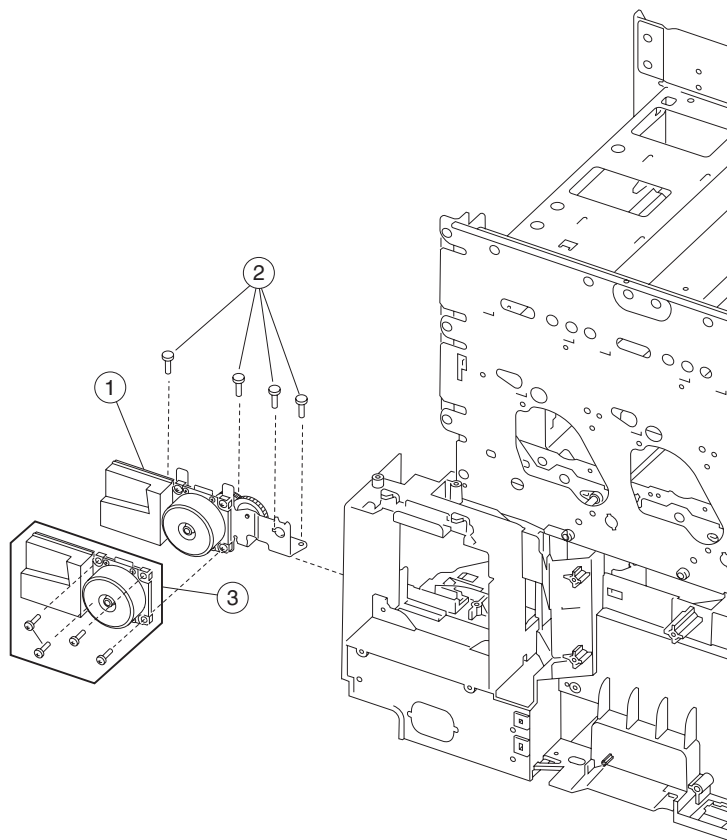

Asm-Index	Part Number	Units	Description
4-1	56P1213	1	Fuser drive assembly w/motor
2		4	Screws PP 12G6309
3	56P1238	1	Fuser drive motor
		4	Screws, motor mounting

Assembly 5: Vacuum transport belt assembly

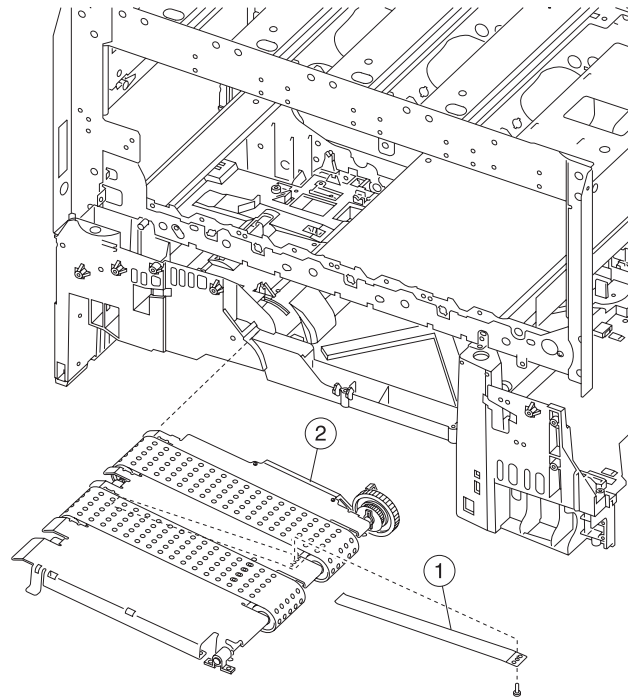

Asm-Index	Part Number	Units	Description
5-1	12G6491	1	Jam access spring
2	12G6489	1	Vacuum transport belt assembly

Assembly 6: Transfer

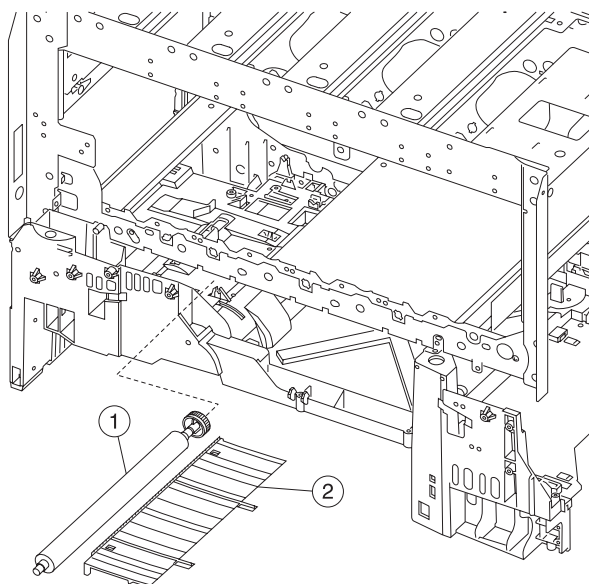

Asm-Index	Part Number	Units	Description
6-1	12G6303	1	Second transfer roll
2	12G6488	1	Transfer plate assembly

Assembly 7: Printheads

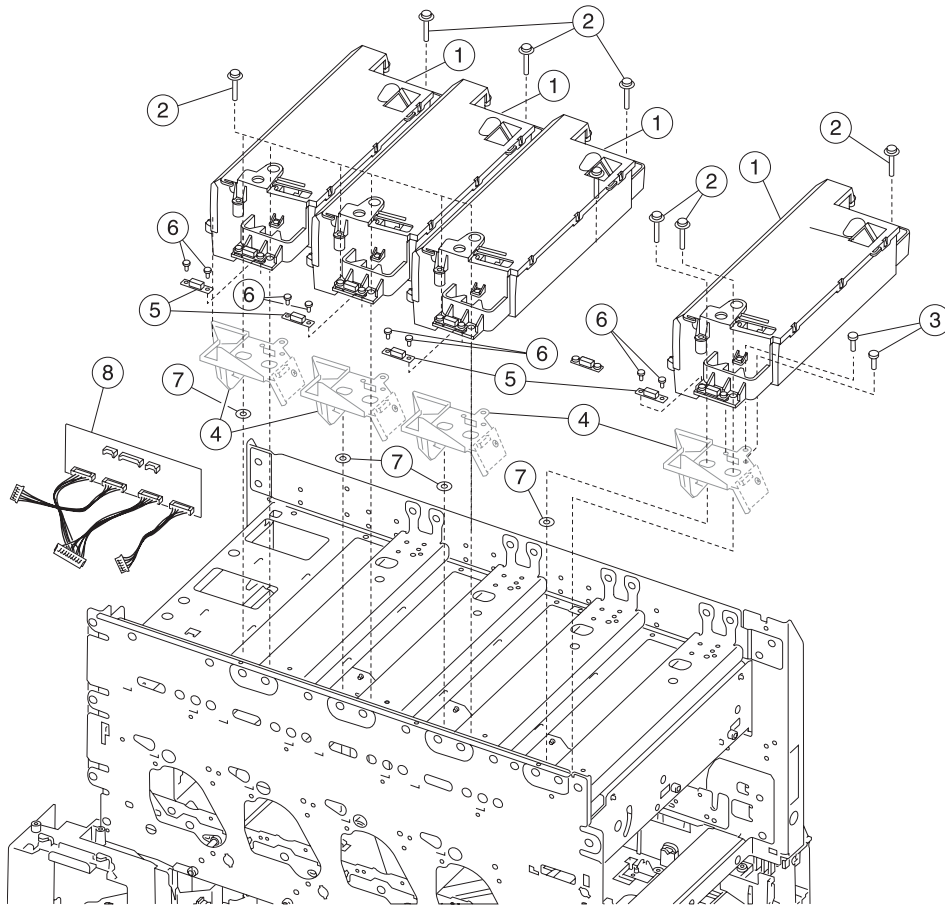

Asm-Index	Part Number	Units	Description
7-1	12G6322	4	Printhead assembly (Do not replace more than one printhead at a time.)
2		12	Screw, PP 12G6534
3		12	Screw, PP 12G6539
4		4	PSD assembly (order 7-5, thermistor card, when replacing this assembly)
5	56P1198	4	Thermistor card
6		8	Screw, PP 12G6533
7	56P2292	4	Printhead spacer
8	56P2296	1	Card assembly, printhead diagnostic aid

Assembly 8: Paper feed output (redrive)

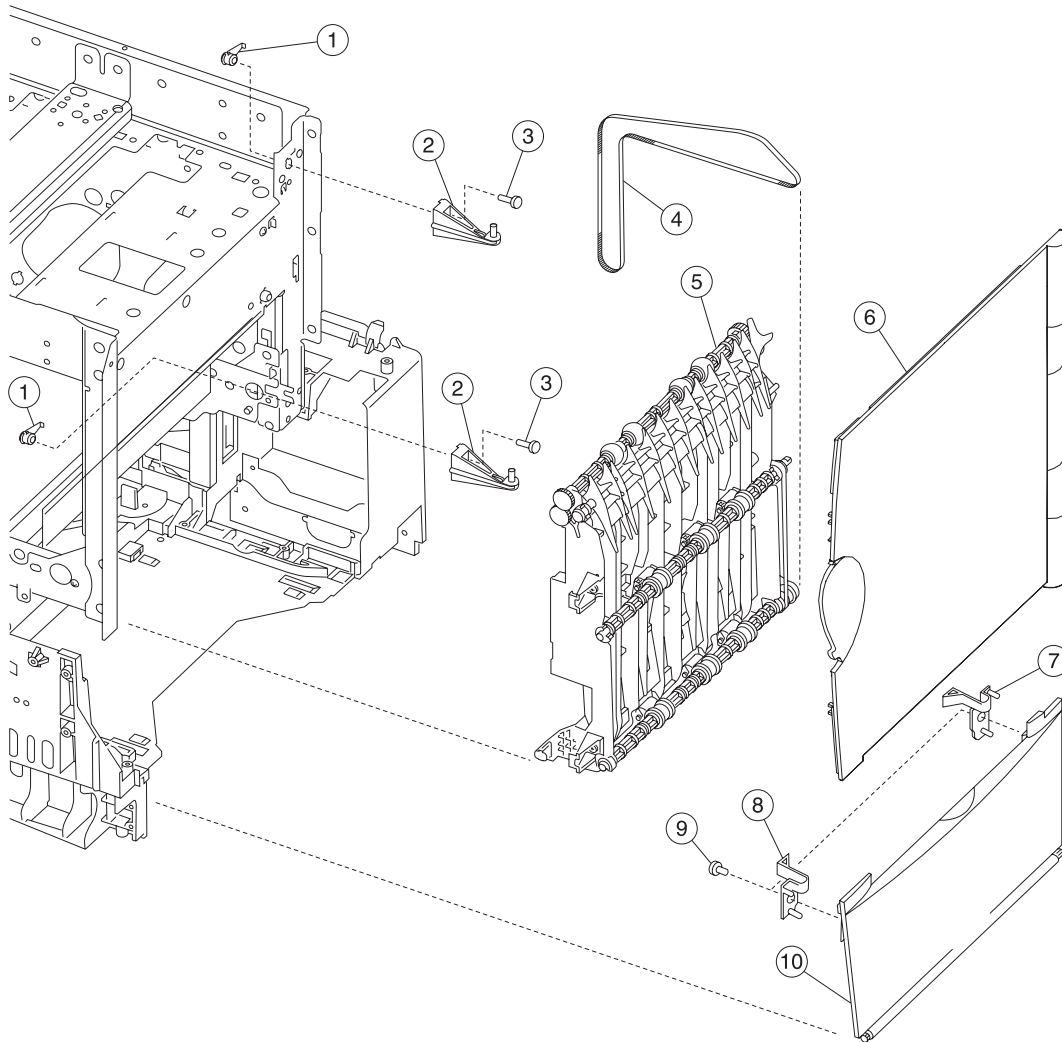

Asm-Index	Part number	Units	Description
8-1	56P0167	8	Anchor, bracket mounting
2	12G6493	2	Upper door hinge
3		2	Screw, PP 12G6533
4	56P2204	1	Redrive belt 300 T
5	12G6492	1	Redrive assembly
6	12G6355	1	Redrive door
7	12G6513	1	Lower rear door latch
8	12G6512	1	Lower front door latch
9		2	Screw, PP 12G6530
10	12G6356	1	Door assembly, lower right

Assembly 9: Paper feed input

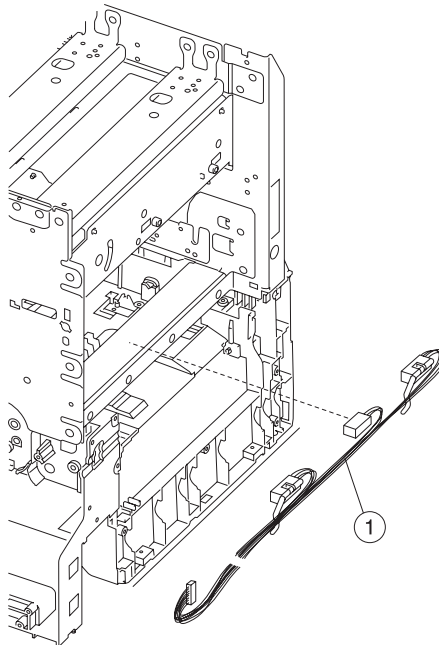

Asm-Index	Part number	Units	Description
9-1	12G6486	1	S2/transparency/narrow media sensor assembly

Assembly 10: Paper size sensing

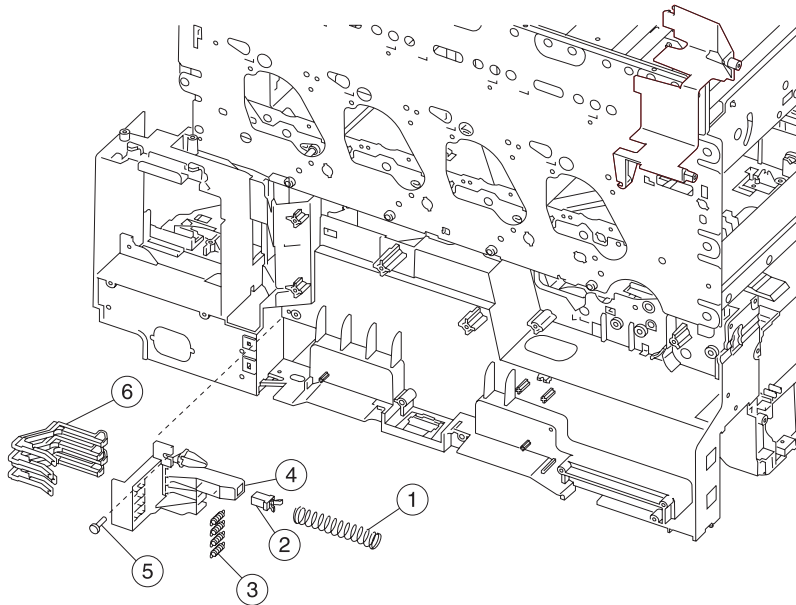

Asm-Index	Part Number	Units	Description
10-1	12G6470	1	Waste container latch spring
2	12G6469	1	Waste container latch
3	12G6467	4	Paper size sensing spring
4	12G6468	1	Paper size sensing bracket
5		1	Screw, paper size sensing assembly mounting PP 12G6531
6	12G6466	4	Paper size sensing link

Assembly 11: Paper feed transport

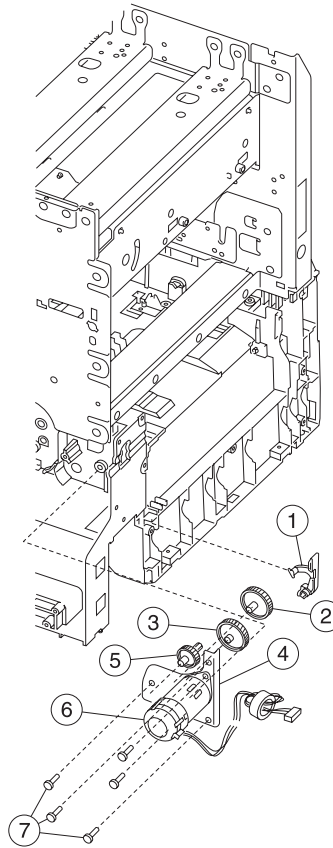

Asm-Index	Part Number	Units	Description
11-1	56P2199	1	Nip relief handle
2	12G6483	1	Gear, staging idler
3	12G6482	1	Gear, staging reduction #1
4	12G6481	1	Registration plate assembly
5	12G6484	1	Gear, reference plate drive
6	12G6480	1	Registration motor
7		3	Registration motor assembly screw, PP 12G6309

Assembly 12: Multipurpose feeder (MPF)

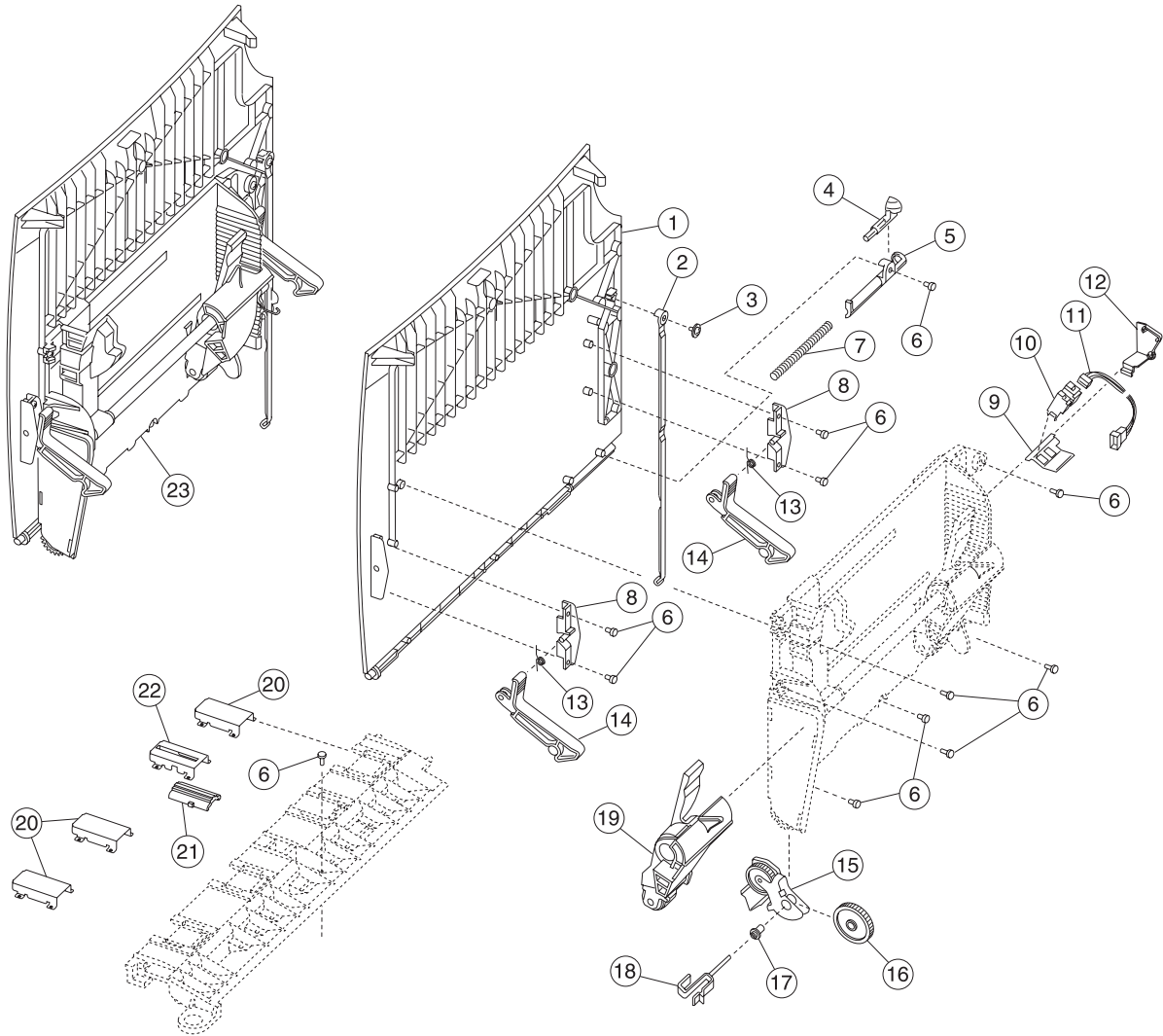

Assembly 12: Multipurpose Feeder (MPF)

Asm- Index	Part number	Units	Description
12-1	12G6452	1	MP feeder door cover
2	12G6460	1	Door hinge restraint
3		1	Screw, PP 12G6533
4	12G6453	1	Frame bias latch
5	12G6455	1	Frame bias latch cover
6		11	Screw, PP 12G6533
7	12G6454	1	Frame bias spring
8	12G6457	2	MPF support bracket cover
9	12G6456	1	Sensor mount bracket
10	12G6461	1	Paper out/low sensor
11	12G6448	1	MPF cable
12	12G6449	1	MPF cable cover
13	12G6458	2	MPF support bracket spring
14	12G6459	2	MPF support bracket
15	12G6462	1	MPF bracket assembly
16	12G6463	1	MPF drive gear
17	12G6465	1	MPF drive gear bushing
18	12G6464	1	MPF drive gear shaft
19	12G6451	1	MPF autocompensator pick assembly
20	12G6354	3	Rib housing
21	12G6447	1	Friction buckler
22	12G6346	1	Buckler housing
23	12G6450	1	MPF door assembly

Assembly 13: 500-sheet integrated tray

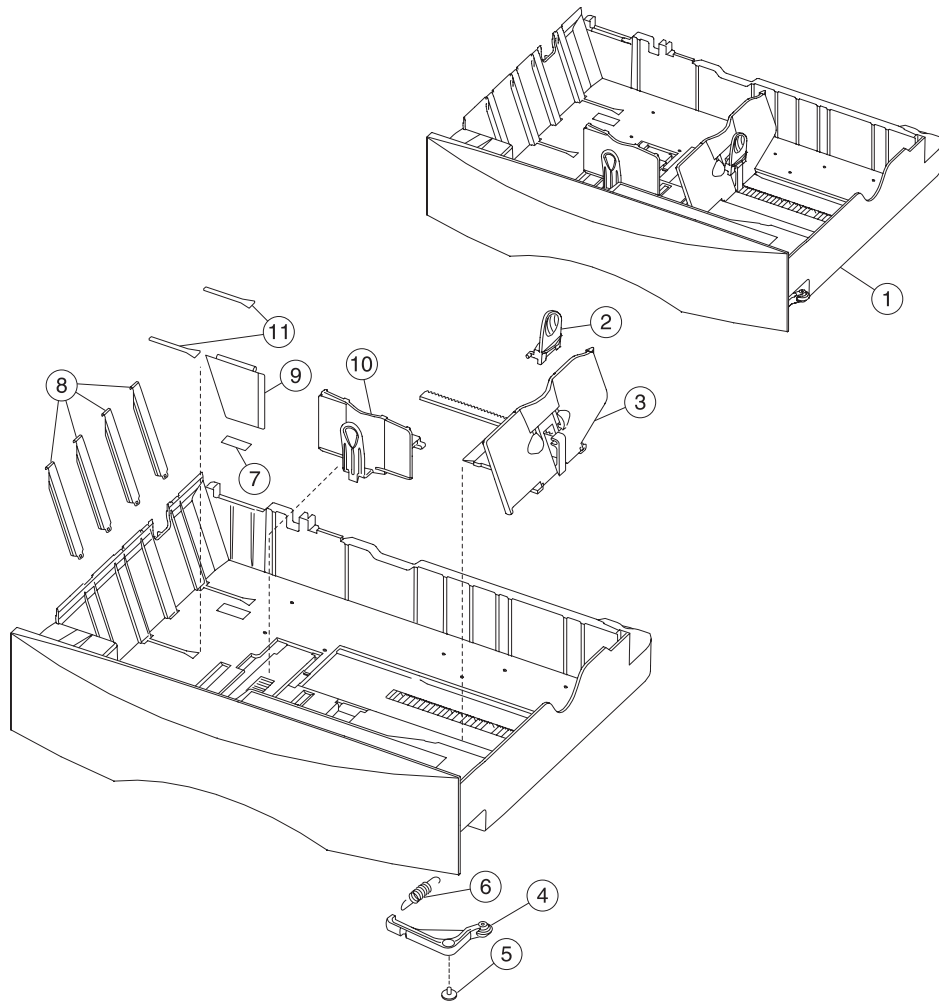

Assembly 13: 500-sheet integrated tray

Asm- Index	Part number	Units	Description
13-1	12G6416	1	500-Sheet tray assembly
2	12G6419	1	Back restraint latch
3	12G6418	1	Back restraint
4	12G6425	1	Tray bias bellcrank assembly
5		1	Screw, PP 12G6533
6	12G6426	1	Tray bias spring
7	12G6568	1	Reflector label
8	12G6421	4	Wear strip
9	12G6420	1	Tray wear clip
10	12G6417	1	Side restraint
11	56P1504	2	Active restraint pad

Assembly 14: Autocompensator assembly

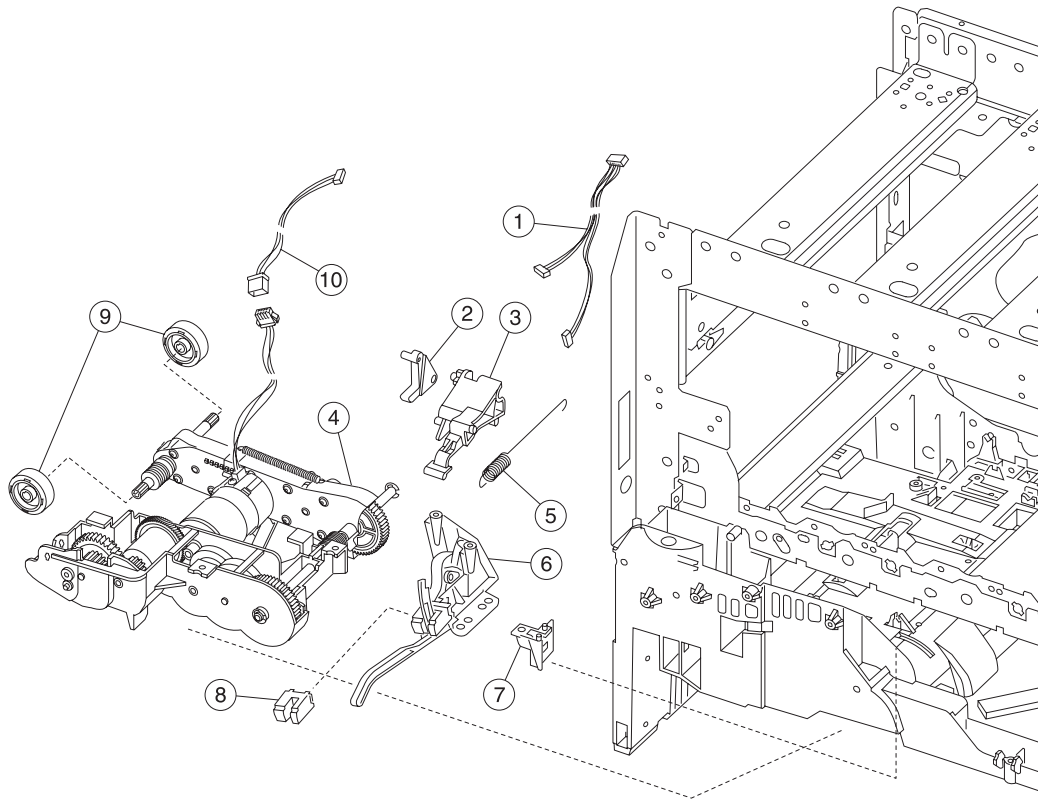

Asm-Index	Part Number	Units	Description
14-1	56P0551	1	Cable, paper media low/out
2	12G6471	1	Tray interlock bellcrank
3	12G6558	1	Pick arm lift bellcrank
4	12G6427	1	Pick assembly 500-tray
5	12G6557	1	Bellcrank lift spring
6	12G6476	1	Paper level sensing assembly
7	12G6472	1	Tray interlock bracket
8	12G6461	1	Sensor, paper out/low
9	99A0070	2	Pick rolls (2 each per package)
10	56P0552	1	Cable, pick motor extension
NS	56P1237	1	Autocomp shaft assembly

Assembly 15: ITU assembly

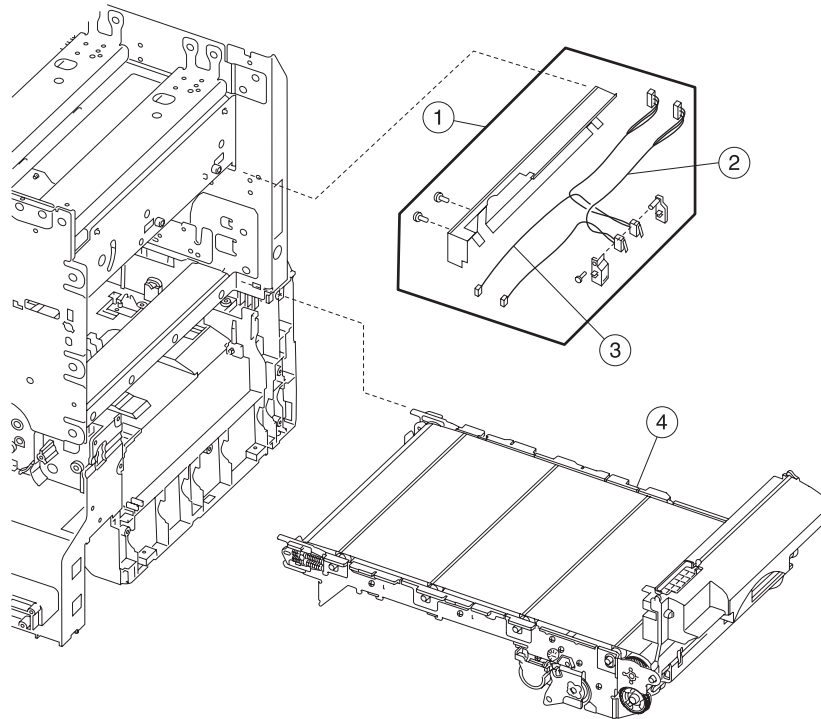

Asm-Index	Part Number	Units	Description
15-1	12G6413	1	ITU light shield assembly
2	12G6503	1	Cable, printhead interlock/cover open (3-wire)
3	12G6504	1	Cable, HVPS interlock/cover open (2-wire)
4	56P1295	1	ITU assembly

Assembly 16: ITU drive assembly

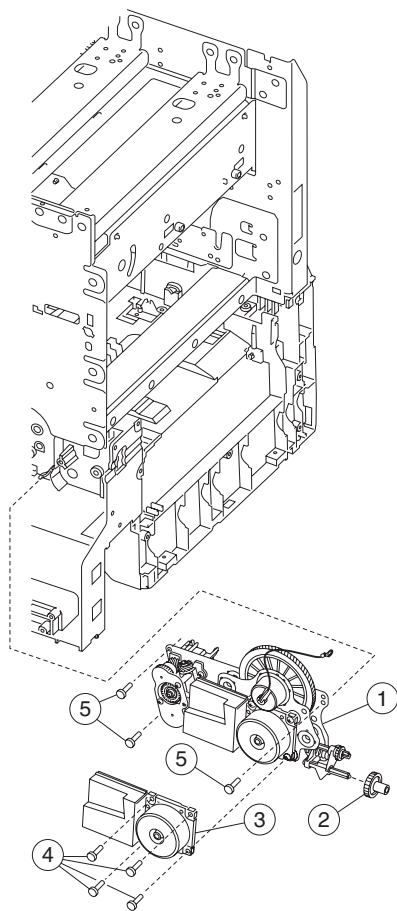

Assembly 16: ITU drive assembly

Asm-index	Part number	Units	Description
16-1	56P1216	1	ITU motor drive assembly with SKC motor
2	12G6385	1	#58 Gear
3	56P0568	1	ITU drive motor, SKC
4		4	Screw, PP 12G6309 (ITU drive motor to ITU drive assembly)
5		4	Screw, PP 12G6309 (ITU drive assembly lower frame)

Assembly 17: ITU loading

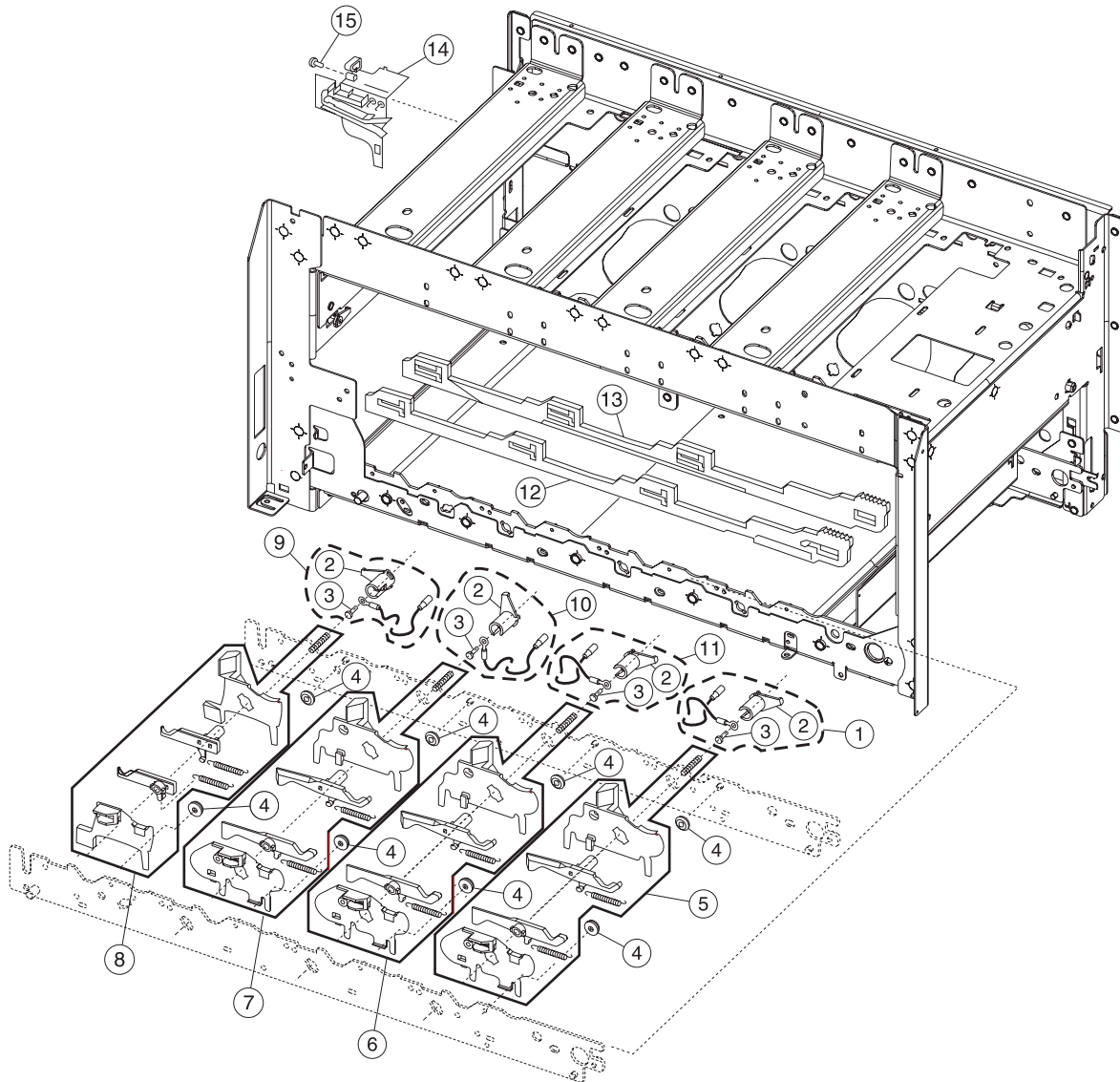

Assembly 17: ITU loading

Asm-Index	Part number	Units	Description
17-1	12G6546	1	Yellow terminal contact assembly
2	12G6442	4	Terminal, contact spring
3		4	Screw PP 12G6533
4	12G6353	8	Cartridge support roller
5	56P1495	1	Parts packet, ITU loading - yellow, including - Yellow BOR spring - Rear block guide - Rear transfer bellcrank - Front V block guide - Front transfer bellcrank - High voltage contact spring
6	56P1496	1	Parts packet, ITU loading - cyan, including - Cyan BOR spring - Rear V block guide - Rear transfer bellcrank - Front V block guide - Front transfer bellcrank - High voltage contact spring
7	56P1497	1	Parts packet, ITU loading - magenta, including - Magenta BOR spring - Rear V block guide - Rear transfer bellcrank - Front V block guide - Front transfer bellcrank - High voltage contact spring
8	56P1498	1	Parts packet, ITU loading - black, including - Black BOR spring - Rear block guide - Rear transfer bellcrank - Front V block guide - Front transfer bellcrank - High voltage contact spring
9	12G6439	1	Black terminal contact assembly
10	12G6440	1	Magenta terminal contact assembly
11	12G6441	1	Cyan terminal contact assembly
12	56P0594	1	Cam, BOR front
13	56P0595	1	Cam, BOR rear
14	56P0560	1	Rear ITU guide
15		1	Screw, PP 12G6309

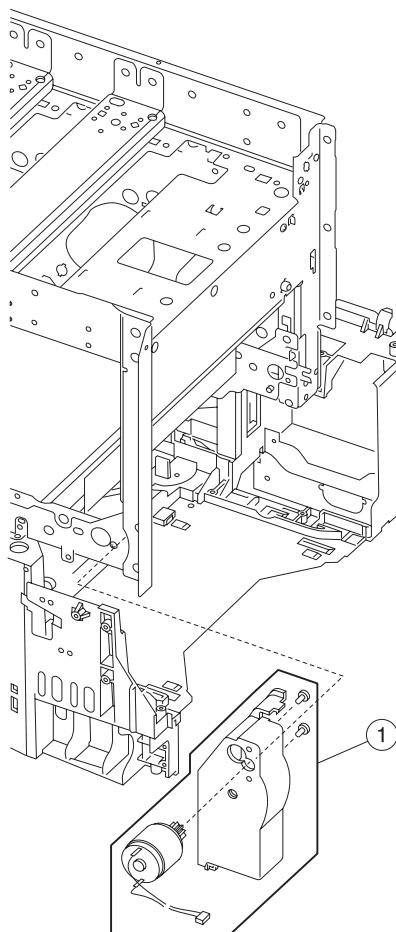
Assembly 18: BOR drive assembly

Asm-Index	Part number	Units	Description
18-1	12G6446	1	BOR housing assembly with motor

Assembly 19: Cartridge contact assembly

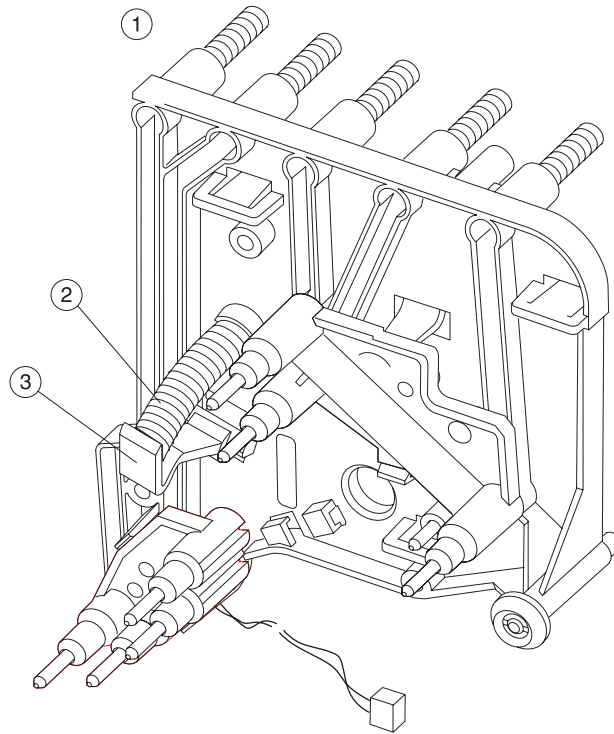

Asm-Index	Part number	Units	Description
19-1	56P0310	4	Cartridge contact assembly, complete
2	12G6377	1	Rear hold down bellcrank
3	12G6376	1	Rear hold down spring

Assembly 20: Cartridge drive assembly

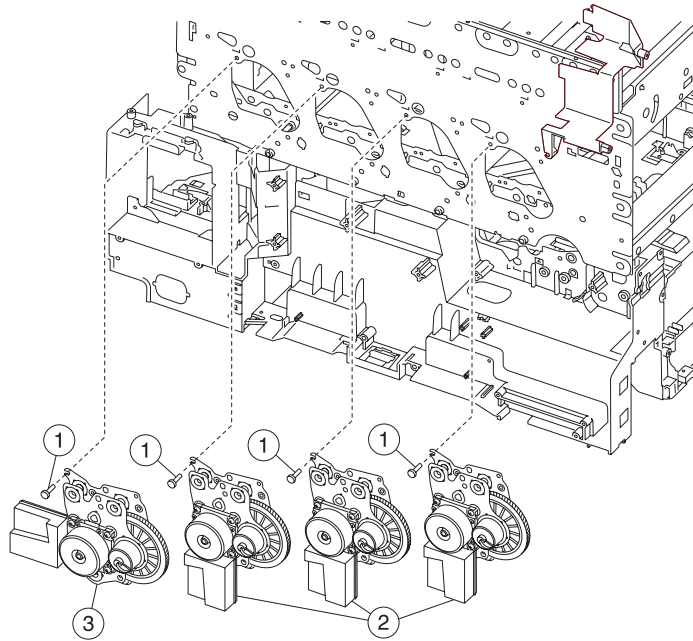

Assembly 20: Cartridge drive assembly

Asm- Index	Part Number	Units	Description
20-1		4	Screw, PP 12G6530
2	56P1214	3	Cartridge drive assembly, cyan/magenta/black
3	56P1215	1	Cartridge drive assembly, yellow

Assembly 21: Electronics

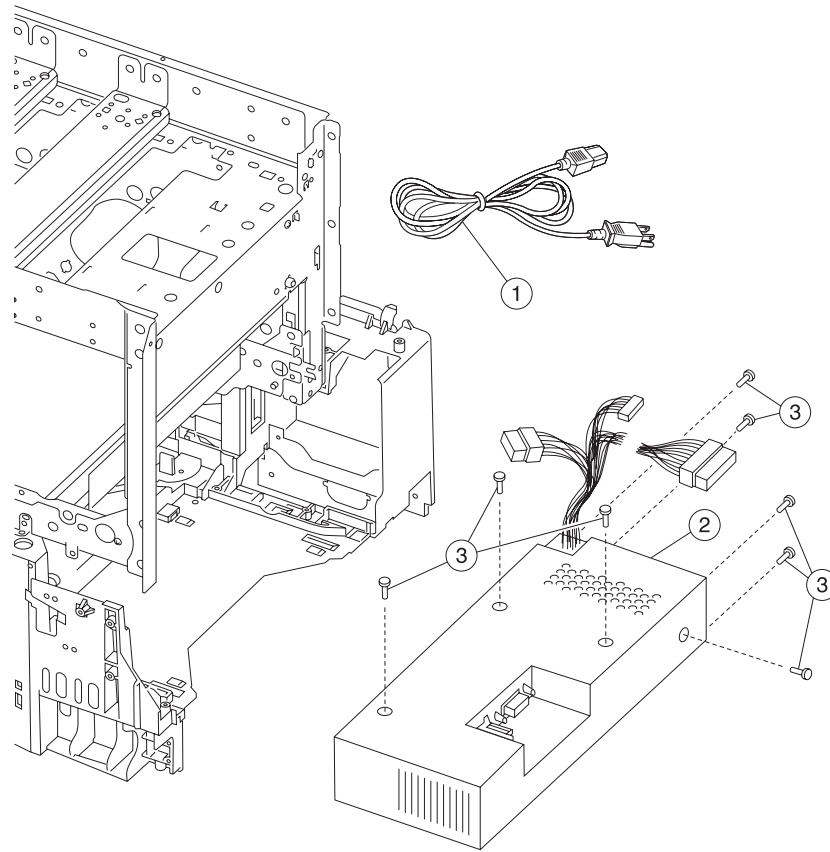

Assembly 21: Electronics

Asm-Index	Part number	Units	Description
21-1	11A9095	1	Power cord set U.S., Canada (LV), Brazil (LV), Colombia (LV), Costa Rica (LV), Dominican Republic (LV), Ecuador (LV), El Salvador (LV), Guatemala (LV), Honduras (LV), Nicaragua (LV), Panama (LV), Venezuela (LV), Puerto Rico (LV), Virgin Islands (LV) Mexico (LV), Asia Pacific (English) LV, Japan (LV), Taiwan (LV), Saudi Arabia (LV),
1	43H5544	1	Power cord set PRC (HV)
1	1339517	1	Power cord set Bolivia (HV), Peru (HV)
1	1339519	1	Power cord set Kuwait (HV), Bahrain (HV), Qatar (HV), UAE (HV), Oman (HV) Pakistan (HV), Yemen (HV), Iraq (HV), Libya (HV), Cyprus (HV), UK (HV), Ireland (HV)
1	1339520	1	Power cord set Brazil (HV), Paraguay (HV), Uruguay (HV), African Countries Denmark (HV), Austria (HV), Czech (HV) Slovak countries (HV), Greece (HV), Hungary (HV), Finland (HV), Norway (HV), Sweden (HV), France (HV), Belgium (HV), Netherlands (HV), Germany (HV), Italy (HV), Lebanon (HV), Syria (HV), Egypt (HV), Jordan (HV), Iran (HV), Euro English (HV), Albania (HV), Bosnia (HV), Bulgaria (HV), Croatia (HV), Slovenia (HV), Macedonia (HV), Yugoslavia (Serbia and Montenegro) (HV), Romania (HV), Iceland (HV) Poland (HV), Russia (HV), Turkey (HV), CIS (HV), Spain (HV), Catalan (HV), Portugal (HV),
1	1339521	1	Power cord set Israel (HV)
1	1339522	1	Power cord set Switzerland HV (French/German and Italian)
1	1339523	1	Power cord set South Africa (HV), Namibia (HV), Lesotho (HV), Botswana (HV)
1	1339524	1	Power cord set Chile (HV)
1	1339525	1	Power cord set Denmark, (HV)
1	1339544	1	Power cord set Argentina (HV)
2	12G6329	1	LVPS, 115V
2	12G6330	1	LVPS, 220V
3		8	Screw, PP 12G6540

Assembly 21.1: Electronics

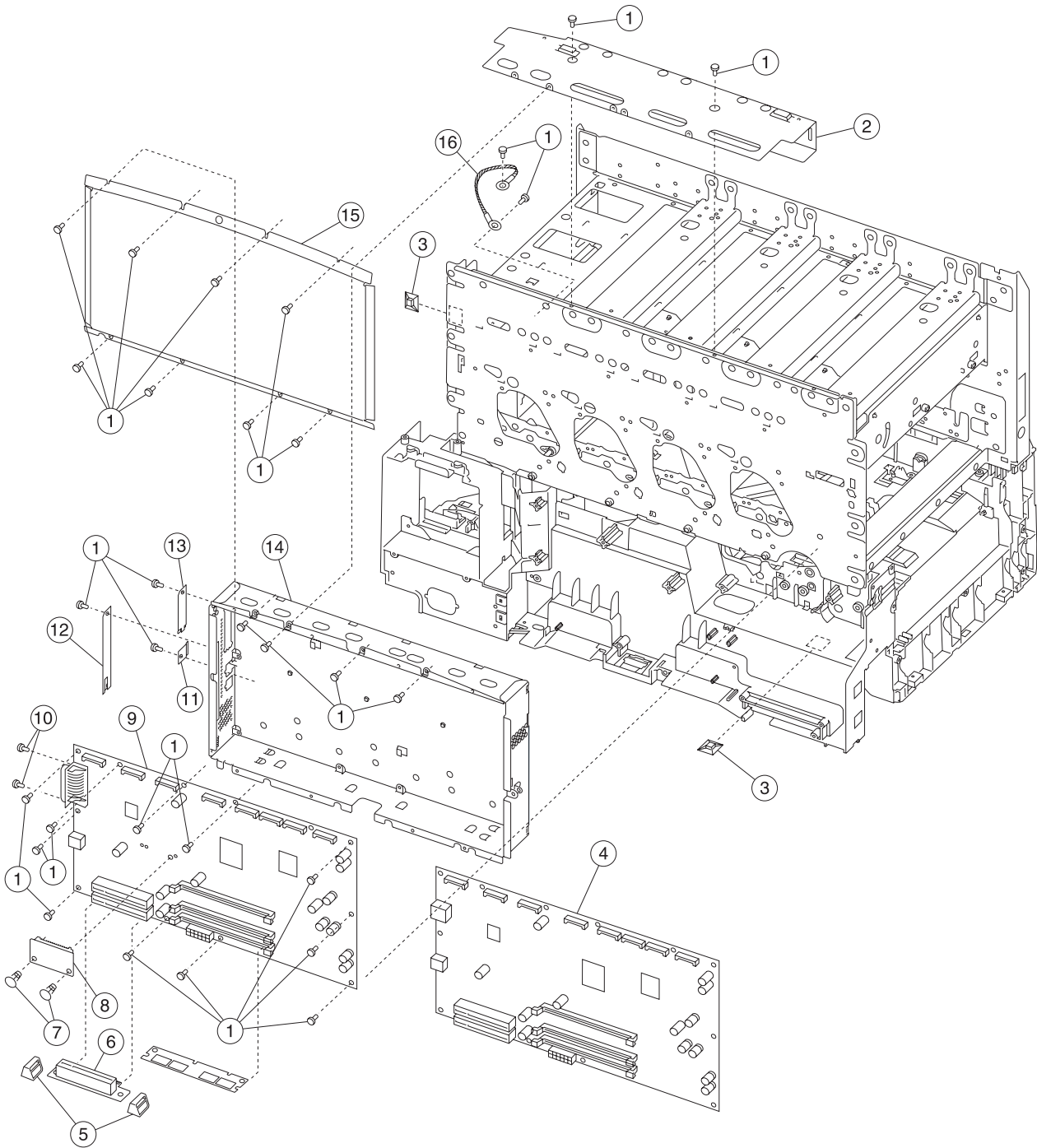

Assembly 21.1: Electronics

Asm- Index	Part number	Units	Description
21.1-1		22	Screw, PP 12G6309
2	12G6331	1	RIP board ground shield
3	12G6511	2	Cable mount
4	56P1188	1	RIP board assembly - network, model 5060-002
5	12G6334	2	INA riser support bracket
6	12G6326	1	Riser card assembly w/o support brackets
7	12G6335	1	Standoff, INA RIP spacer
8	56P9910	1	SDRAM DIMM 128MB
8	12G6509	1	SDRAM DIMM 64MB
9	56P1187	1	RIP board assembly, non-network, Model 5060-001
10	99A0426	1	Screw, parallel connector mounting
11	99A1611	1	Ethernet blank shield, use with non-network RIP boards
12	99A0408	1	INA blank flat shield, use when options are not installed
13	99A2432	1	Blank parallel shield, use with network RIP boards
14	12G6333	1	RIP board shield assembly
15	12G6332	1	RIP board cover shield
16	12G6487	1	Ground strap

Assembly 21.2: Electronics

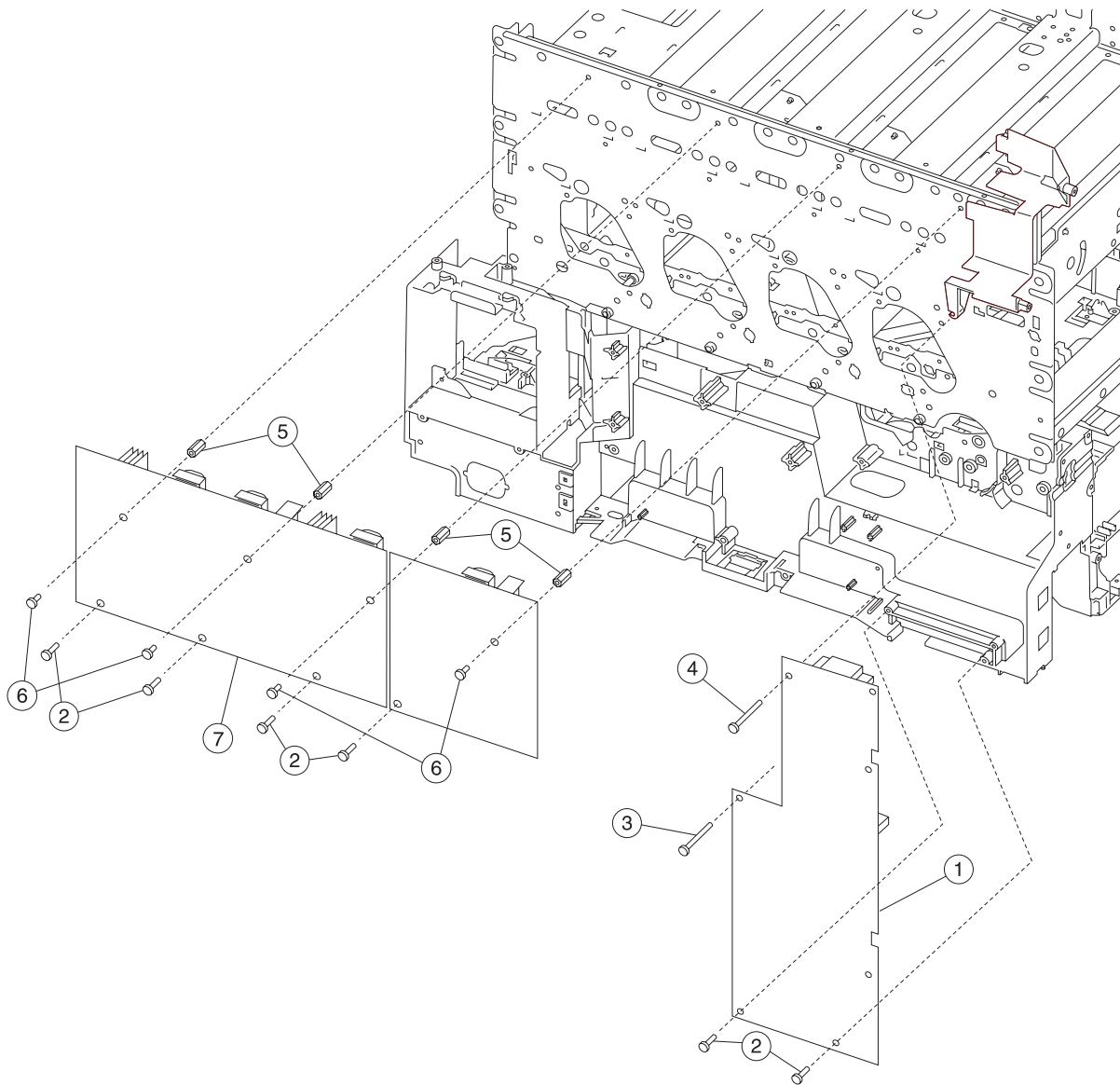

Asm-Index	Part number	Units	Description
21.2-1	12G6327	1	Transfer HVPS board
2		1	Screw, PP 12G6309
3		1	Screw, PP 12G6533
4		1	Screw, PP 12G6530
5	12G6541	4	Standoff, high voltage power supply - developer
6		4	Screw, PP 12G6540
7	12G6328	1	Developer HVPS board

Assembly 21.3: Electronics

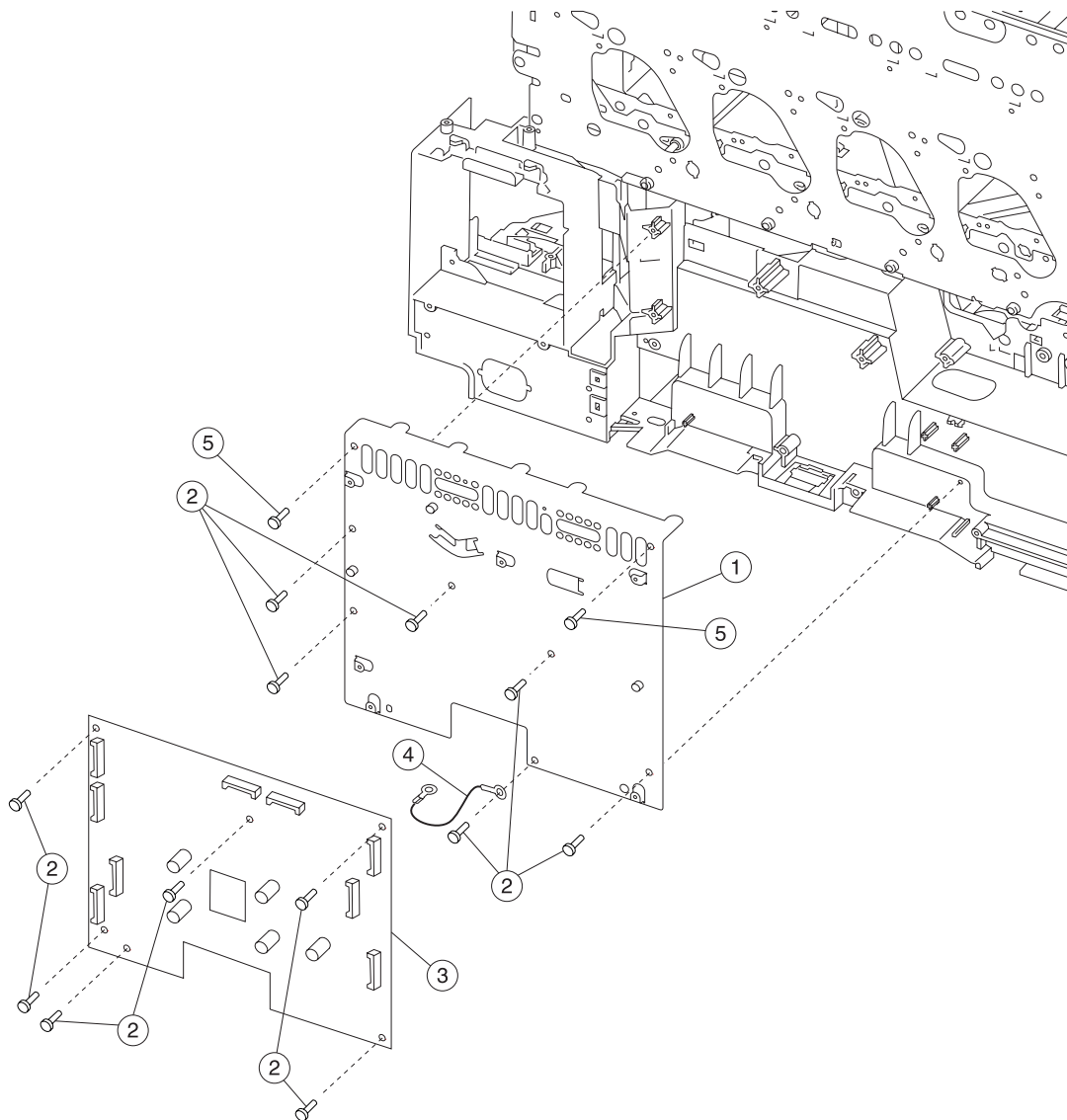

Asm-Index	Part Number	Units	Description
21.3-1	12G6336	1	Engine board shield
2		12	Screw, PP 12G6531
3	12G6323	1	Engine board
4	12G6387	1	Ground strap
5		14	Screw, PP 12G6309

Assembly 21.4: Electronics

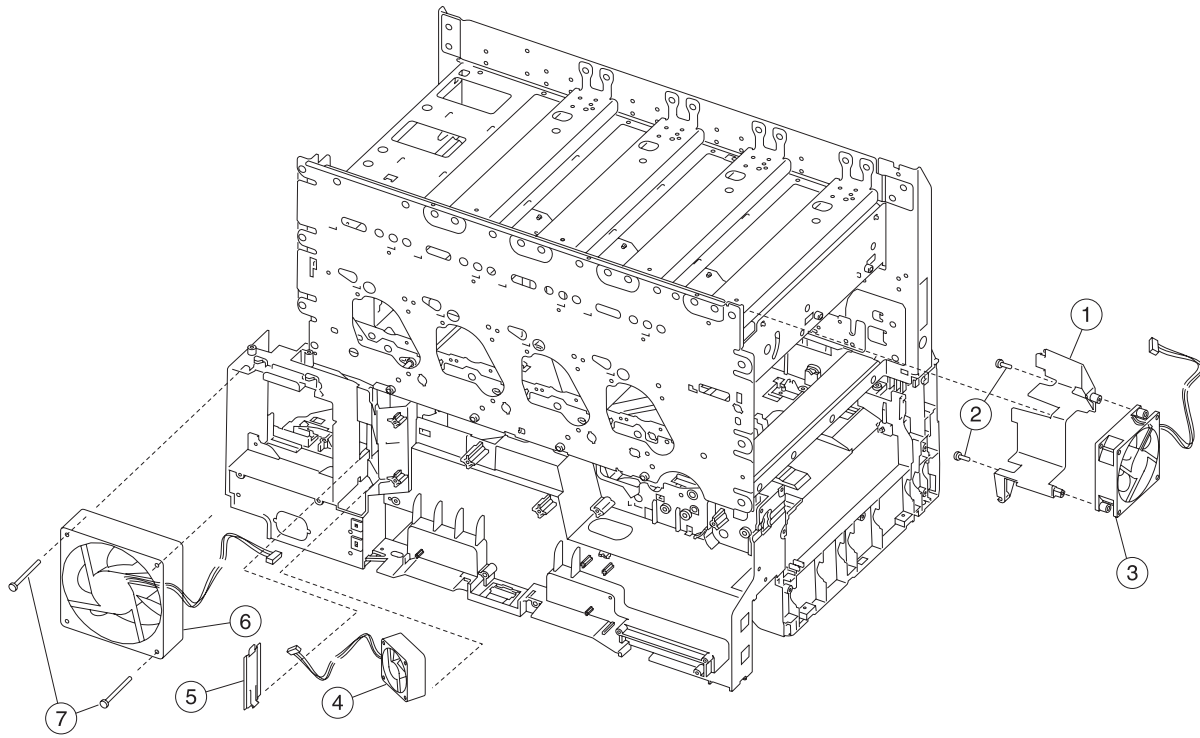

Assembly 21.4: Electronics

Asm- Index	Part Number	Units	Description
21.4-1	12G6343	1	RIP fan duct
2		2	Screws, PP 12G6530
3	12G6361	1	RIP fan
4	12G6479	1	VTB fan
5	12G6490	1	VTB fan gap cover
6	12G6382	1	Fuser fan
7	12G6529	2	Screws, fuser fan mounting

Assembly 22: Electronic cabling—engine board

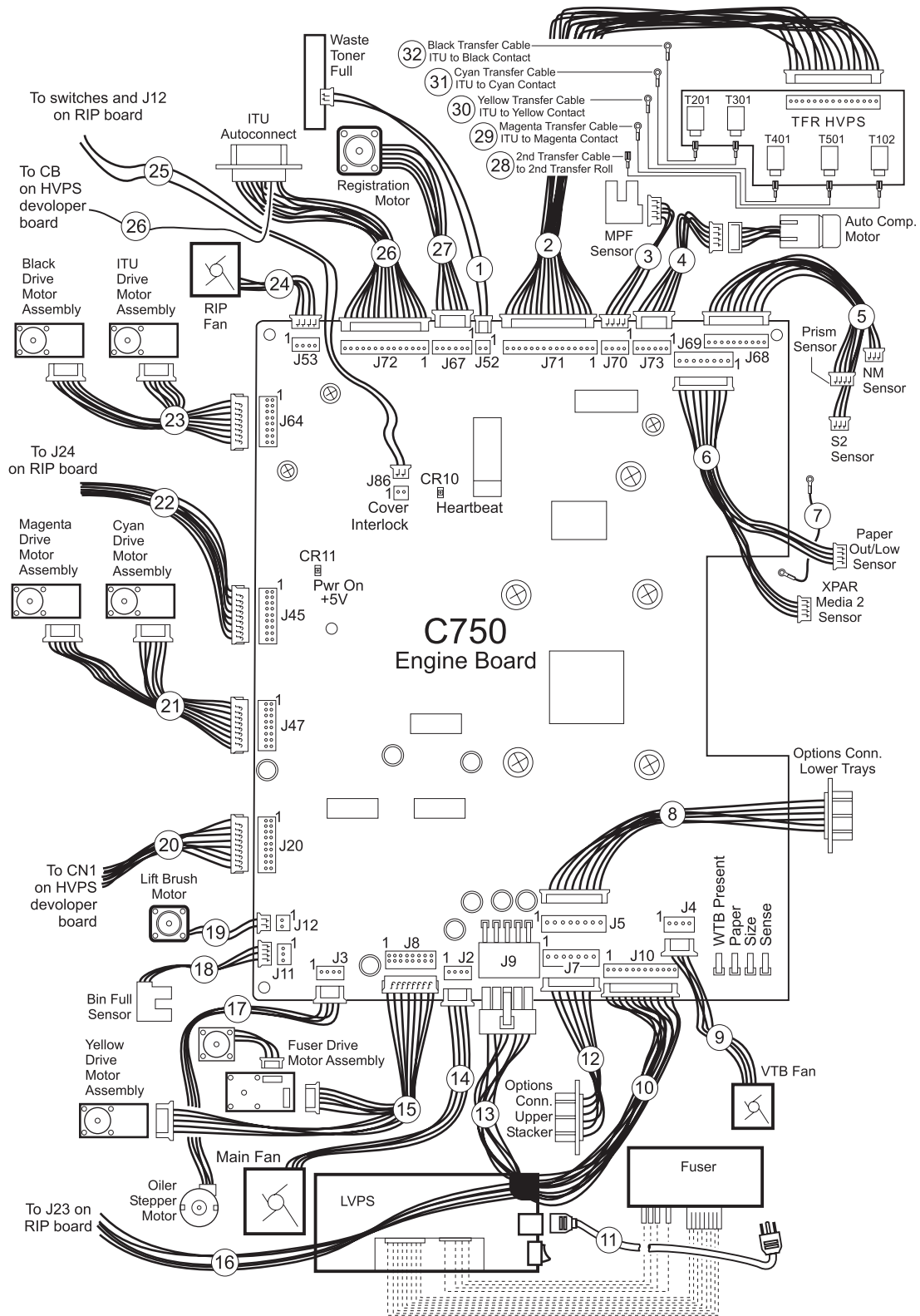

Assembly 22: Electronic cabling—engine board

Asm- Index	Part Number	Units	Description
22—1		1	Cable, waste toner full, attached to ITU drive assembly (P/N 56P1216)
2	12G6317	1	Cable, HVPS control - transfer
3	12G6448	1	Cable, MPF paper level
4	56P0552	1	Cable, autocompensator motor
5	12G6486	1	Cable assembly (includes S2/NMS/transparency sensors)
6	56P0551	1	Cable, paper out/low and transparency media 2 sensors
7	12G6387	1	Cable, ground
8	12G6320	1	Cable, options - bottom
9		1	Cable, attached to VTB fan (P/N 12G6479)
10		1	Cable, LVPS to engine board/fuser, attached to LVPS (P/N 12G6329)
11		1	Power cord (see “Electronics” on page 7-34 for a listing of part numbers)
12	12G6319	1	Cable, options - stacker
13		1	Cable, LVPS to engine/power, attached to LVPS (P/N 12G6329)
14	12G6350	1	Cable, attached to main fan (P/N 12G6382)
15	12G6349	1	Cable, fuser and yellow cartridge motor
16		1	Cable, LVPS to RIP board power, attached to LVPS (P/N 12G6329)
17	56P2031	1	Cable, web oiler motor
18		1	Cable, bin full sensor, with sensor (P/N 12G6506)
19		1	Cable, attached to BOR lift motor (P/N 12G6446)
20	12G6316	1	Cable, HVPS control - developer
21	12G6350	1	Cable, cyan and magenta cartridge drive motors
22	12G6318	1	Cable, engine/RIP communications
23	12G6351	1	Cable, ITU and black cartridge drive motors
24		1	Cable, attached to RIP fan (P/N 12G6361)
25	12G6504	1	Cable, HVPS interlock/cover open
26	56P0311	1	Cable ITU autoconnect
27		1	Cable, attached to registration motor (P/N 12G6480)
28	56P0174	1	Cable, second transfer roll
29	12G6440	1	Cable, magenta transfer
30	12G6546	1	Cable, yellow transfer
31	12G6441	1	Cable, cyan transfer
32	12G6439	1	Cable, black transfer

Assembly 23: Electronic cabling—RIP board

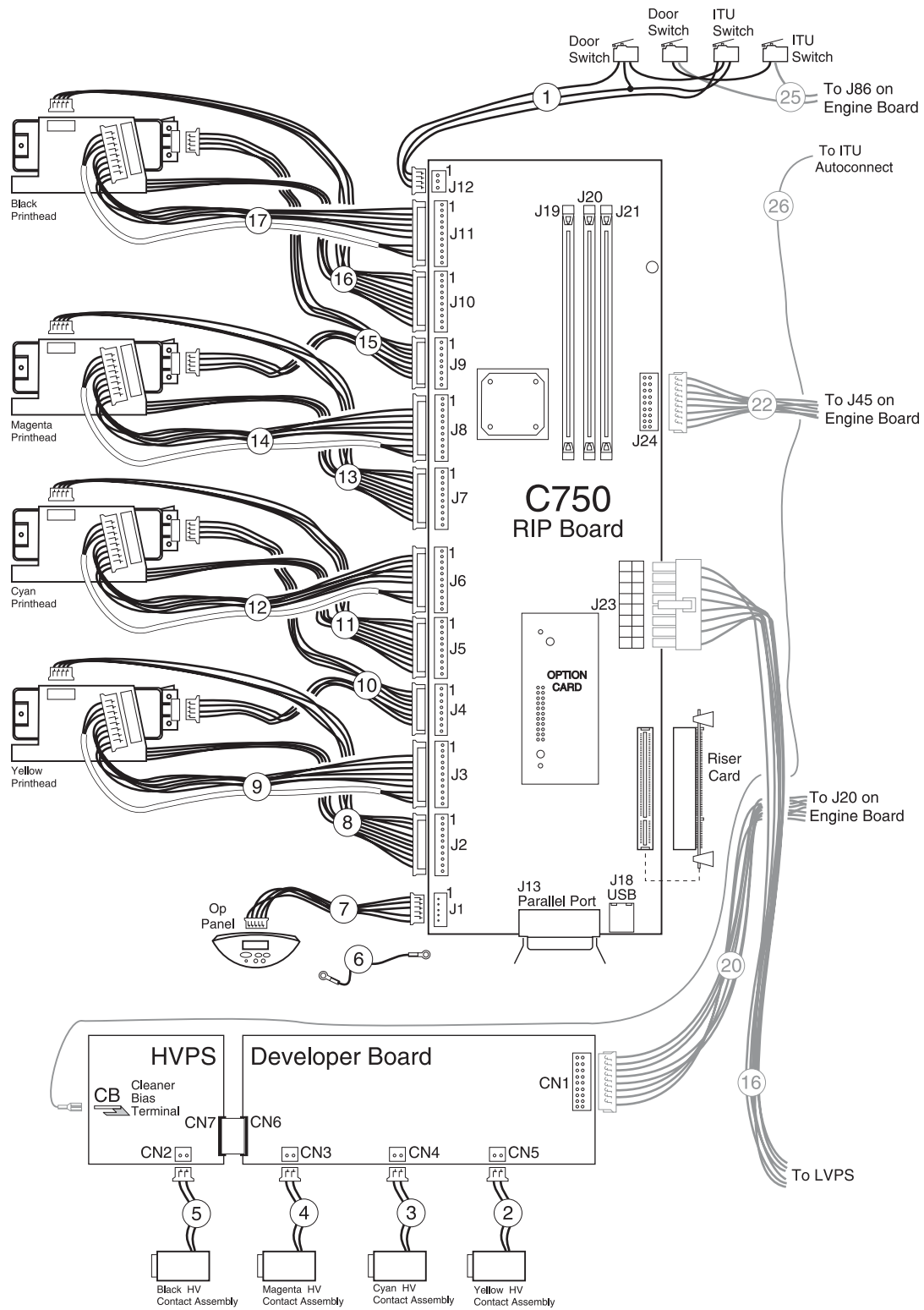

Assembly 23: Electronic cabling—RIP board

Asm- Index	Part Number	Units	Description
23—1	12G6503	1	Cable, printhead interlock/cover open
2	56P0310	1	Cable, signature button, attached to yellow HV contact assembly
3	56P0310	1	Cable, signature button, attached to cyan HV contact assembly
4	56P0310	1	Cable, signature button, attached to magenta HV contact assembly
5	56P0310	1	Cable, signature button, attached to black HV contact assembly
6	12G6387	1	Cable, ground
7	12G6321	1	Cable, operator panel
8		1	Printhead assembly - yellow, includes HSYNC and mirror motor cables (P/N 12G6322)
9	12G6310	1	Cable, video printhead - yellow
10	12G6314	1	Cable, thermistor - yellow and cyan
11		1	Printhead assembly - cyan, includes HSYNC and mirror motor cables (P/N 12G6312)
12	12G6311	1	Cable, video printhead - cyan
13		1	Printhead assembly - magenta, includes HSYNC and mirror motor cables (P/N 12G6322)
14	12G6312	1	Cable, video printhead - magenta
15	12G6315	1	Cable, thermistor - magenta and black
16		1	Printhead assembly - black, includes HSYNC and mirror motor cables (P/N 12G6322)
17	12G6313	1	Cable, video printhead - black

Assembly 24: Electronic cabling—transfer HVPS

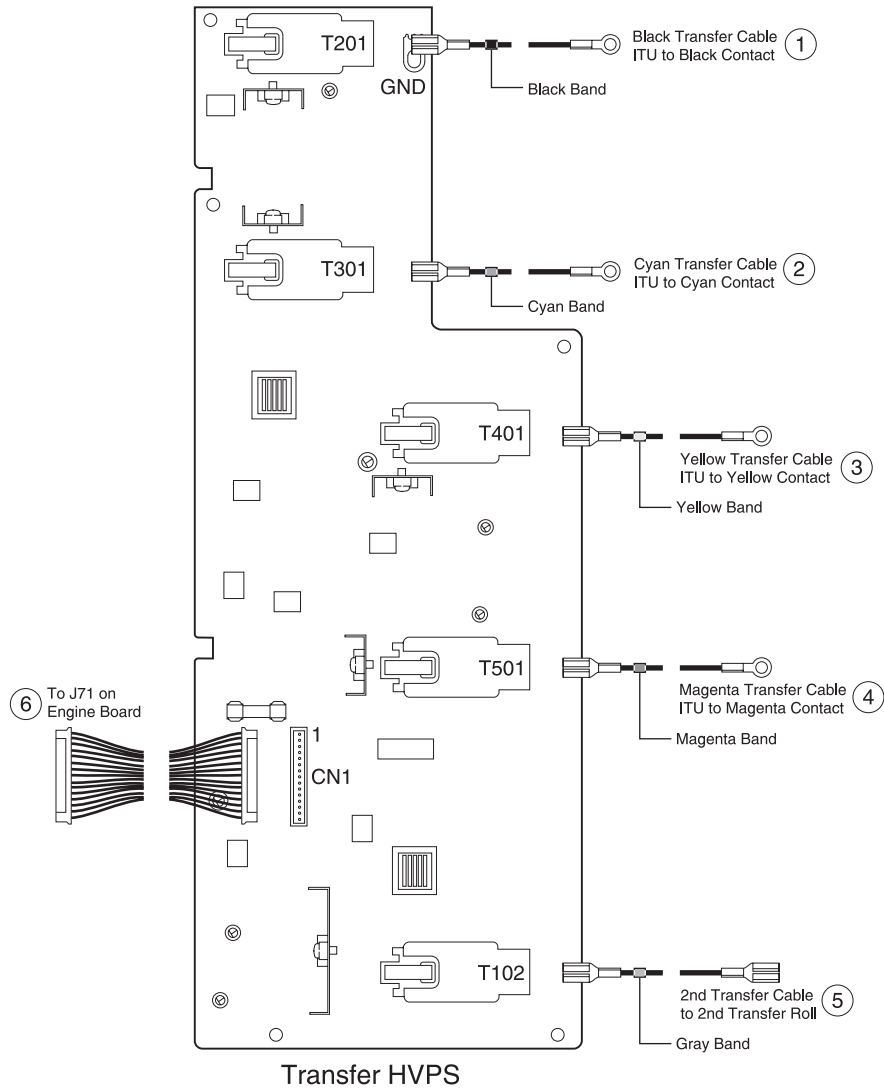

Asm-Index	Part Number	Units	Description
24-1	56P1565	1	Cable assembly, black terminal contact
2	56P1567	1	Cable assembly, cyan terminal contact
3	56P1568	1	Cable assembly, yellow terminal contact
4	56P1566	1	Cable assembly, magenta terminal contact
5	56P0174	1	Cable assembly, second transfer voltage
6	56P1502	1	Cable, HVPS control - transfer

Assembly 25: Electronic cabling—developer HVPS

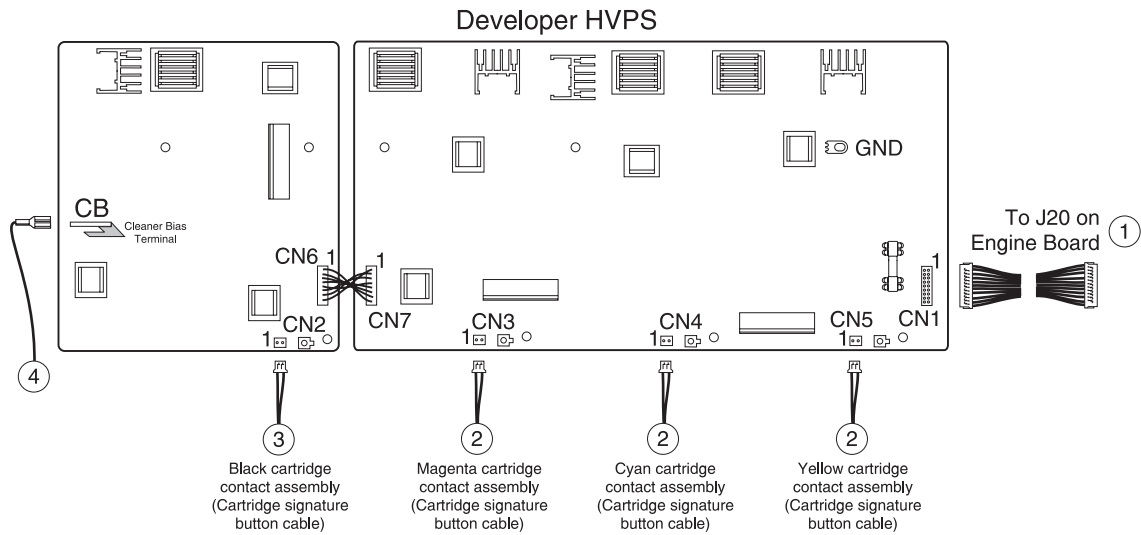

Asm-Index	Part Number	Units	Description
25-1	56P1502	1	Cable assembly, HVPS control - developer
2	56P0310	3	Cartridge contact assembly, complete, cyan/magenta/yellow
3	56P1561	1	Cartridge contact assembly, complete, black
4	56P0311	1	Cable, ITU Autocomp out with CB lead

Assembly 26: Output expander

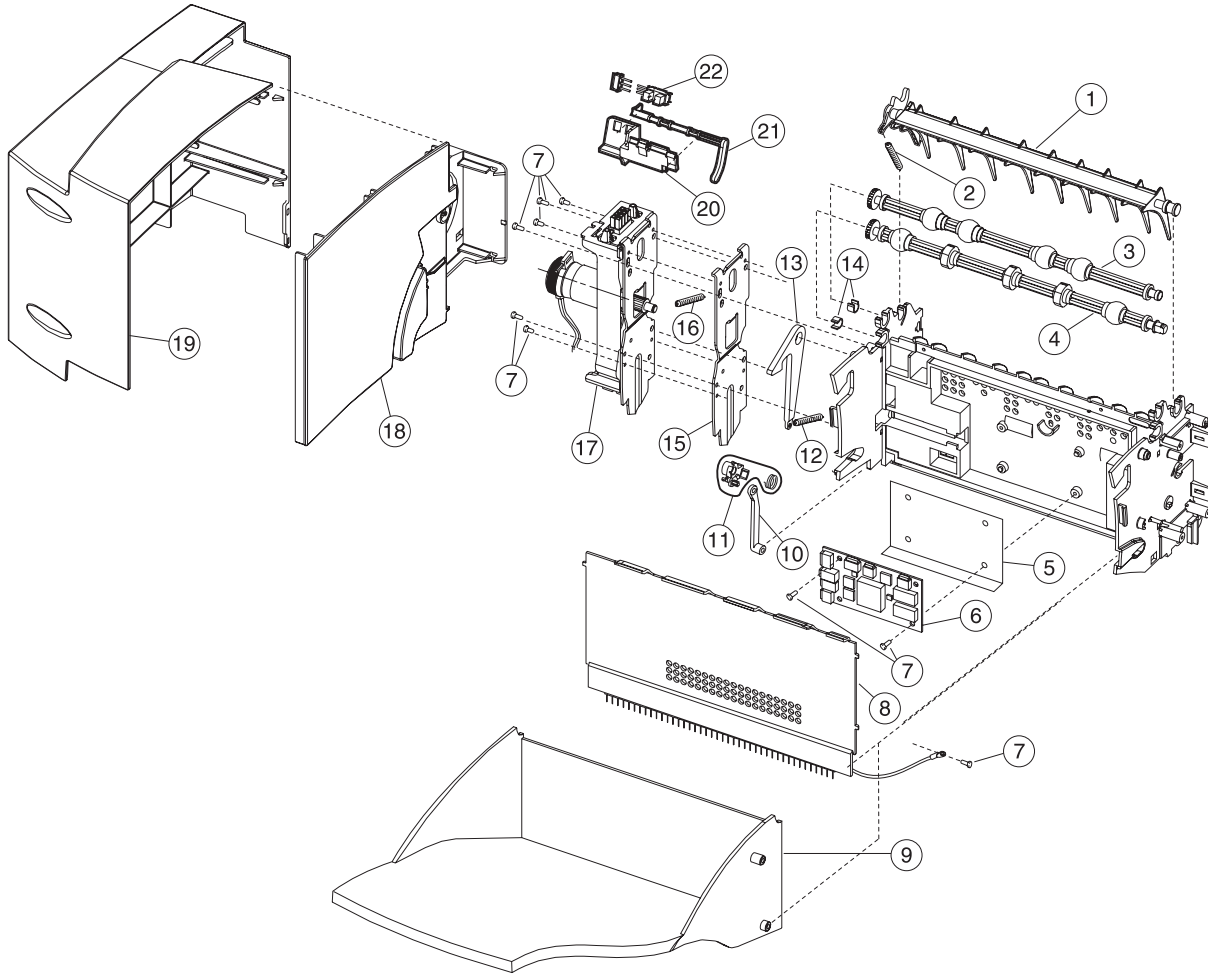

Assembly 26: Output expander

Asm- Index	Part number	Units	Description
26-1	99A0107	1	Deflector, upper redrive, also order 99A0104
2	99A0104	1	Spring, upper diverter
3	99A0369	1	shaft assembly, exit, also order PP 99A0572
4	99A0052	1	Shaft assembly, lower exit, also order PP 99A0572
5	56P0407	1	Shield, output option card
6	99A0915	1	Board, Output Expander DC motor
7		9	Screw, PP 56P0169
8	56P0409	1	Cover, front control board
9	99A1817	1	Tray, Output Expander
10	99A1688	1	Diverter arm
11	99A1689	1	Spring clutch assembly
12	99A0482	1	Spring, output tray
13	99A0481	1	Latch, output tray
14		2	Shaft bearing PP 99A0572
15	99A1784	2	Bracket, attach
16	99A0415	2	Spring, swing arm
17	56P0408	1	Output Expander assembly, mechanical linkage
18	56P0402	1	Cover, rear support
19	56P0401	1	Rear cover
20	99A0409	1	Level sensor bracket
21	99A1580	1	Flag, output paper level
22	99A0414	1	Sensor, dual bin full

Assembly 26.1: Output expander

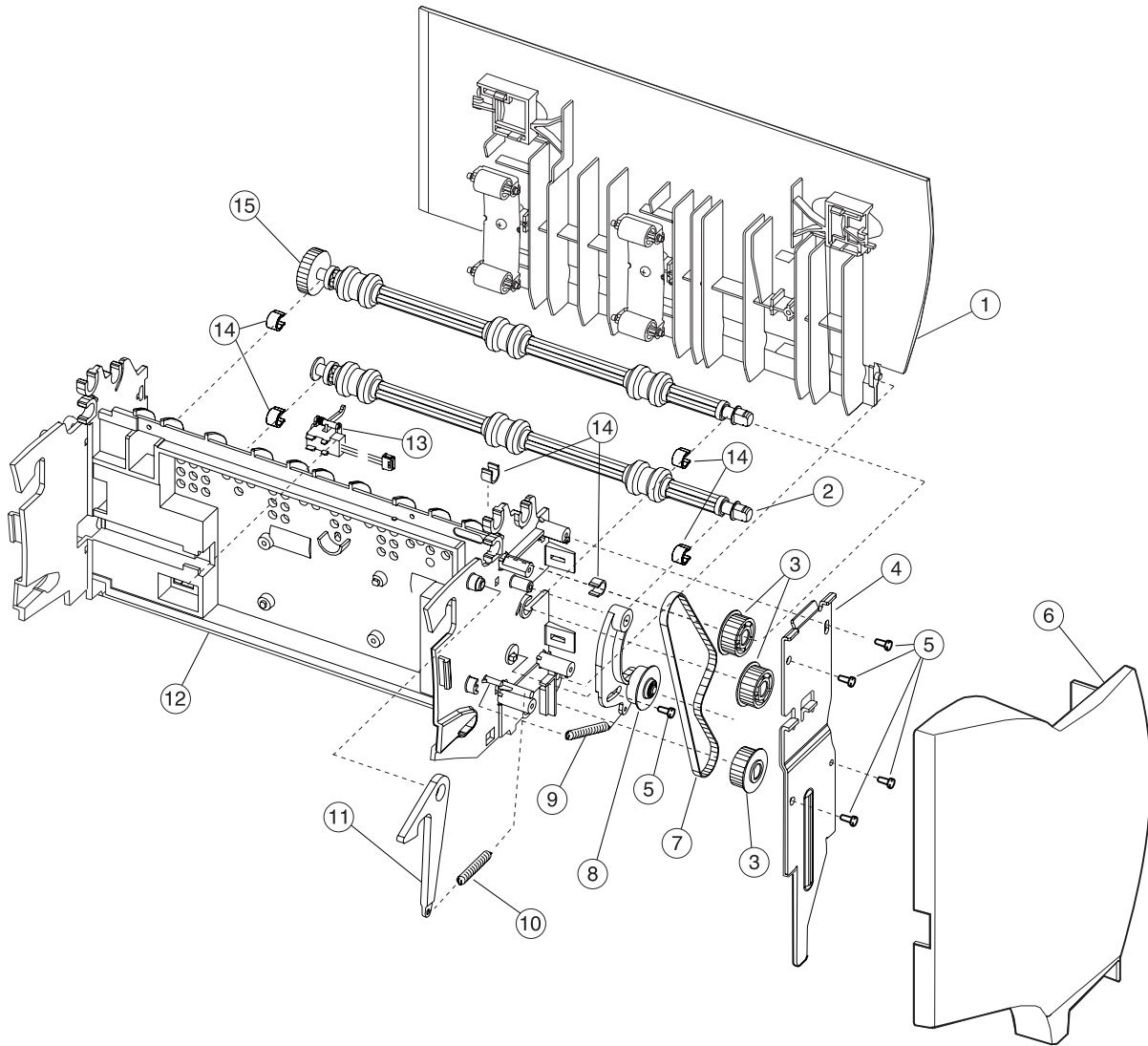

Assembly 26.1: Output expander

Asm- Index	Part number	Units	Description
26.1-1	56P0405	1	Door assembly, right jam access
2	99A0368	1	Shaft assembly, lower, also order PP 99A0572
3	99A0363	3	Pulley, drive
4	56P0410	2	Bracket, attach
5		11	Screw, PP 56P0169
6	56P0400	1	Cover, front
7	99A0361	1	Belt, 160 gear
8	99A0362	1	Arm assembly, belt idler
9	99A0364	1	Spring, belt tensioner
10	99A0482	1	Spring, output tray
11	99A0481	1	Latch, output tray
12	99A0912	1	Frame assembly
13	99A0351	1	Sensor, Output Expander pass thru
14		6	Shaft bearing PP 99A0572
15	99A0913	1	Shaft assembly, middle 40T, also order PP 99A0572
NS	99A1744	1	Kit, Multi-Bin Stacker

Assembly 27: 5-bin mailbox

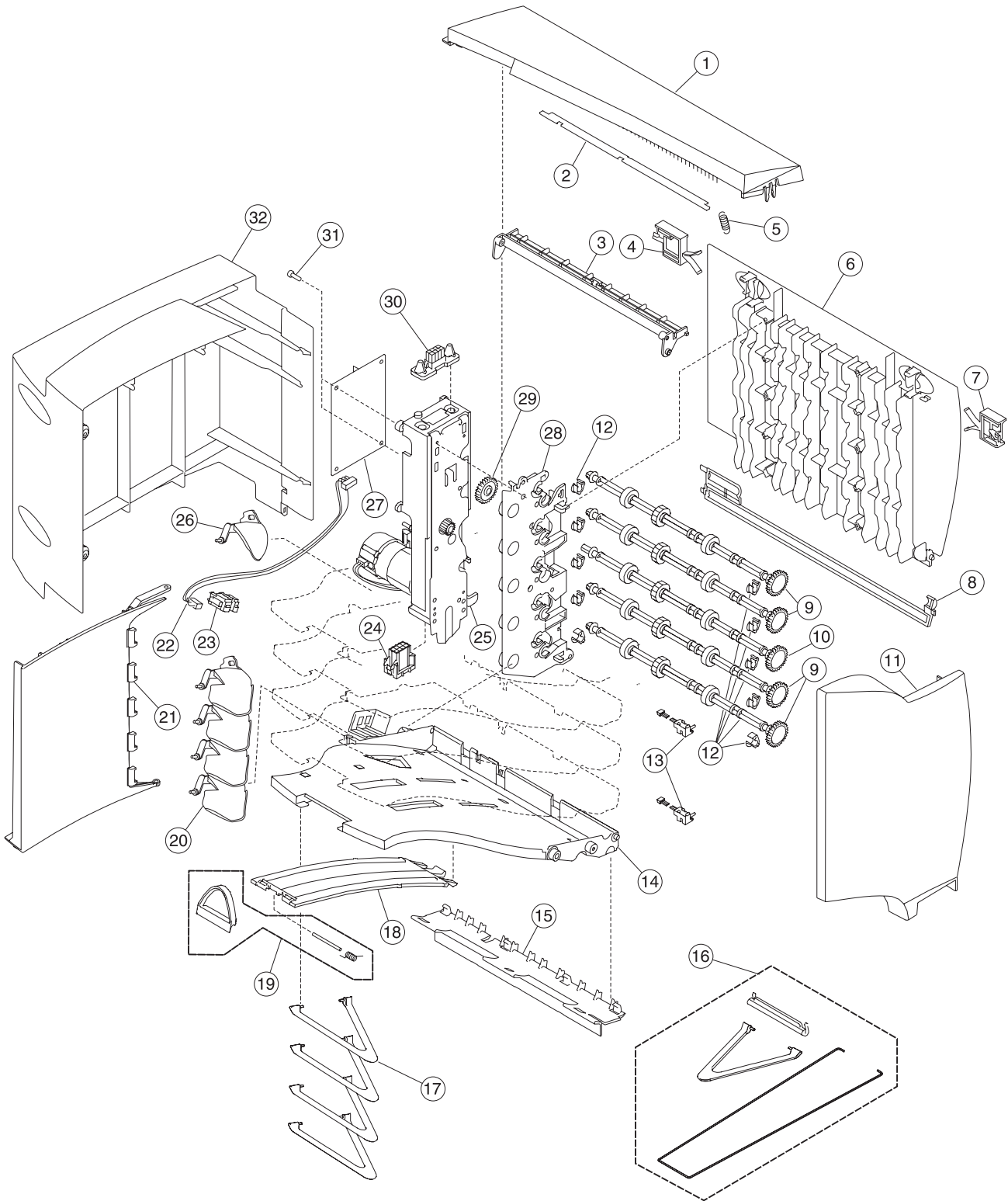

Assembly 27: 5-bin mailbox

Asm- Index	Part number	Units	Description
27-1	12G6409	1	Cover, redrive cap
2	99A1710	1	Cover, wire
3	56P0416	1	Cover, top bin
4	56P0423	1	Latch, rear access door
5	99A0104	1	Spring, upper diverter
6	56P0411	1	Door, front
7	56P0422	1	Latch, access door front
8	56P0415	1	Cover, right
9	99A1723	4	Shaft asm, drive
10	99A1724	1	Shaft asm, drive with gear
11	99A1708	1	Cover, right side
12	99A1725	1	Packet, drive shaft bushing
13	99A1742	2	Sensor, 5-Bin Mailbox pass thru
14	99A1712	5	Tray, paper cap
15	56P0420	1	Bracket asm, bail attach
16	99A1743	1	Kit, 5-Bin Mailbox asm
17		1	Bail, order 99A1743, 5-Bin Mailbox asm kit
18	99A1713	5	Support, paper tray
19	99A1687	5	Stop asm, paper tray
20	99A1735	4	Flag, bin full
21	56P0412	1	Rear structural cover
22	99A1736	5	Cable, dual sensor
23	99A1737	5	Sensor, dual bin level
24	99A1718	1	Cable asm, lower autoconnect
25	99A1716	1	Drive asm, main DC drive
26	56P0417	1	Flag, bin full
27	99A1740	1	Board asm, 5-Bin Mailbox system
28	99A1726	1	Frame asm, left w/clutch asm
29	99A1786	1	Gear, drive
30	99A1719	1	Cable asm, upper autoconnect
31		12	Screw, board mounting, PP 99A0263
32	56P0413	1	Cover, left side

Assembly 27.1: 5-bin mailbox

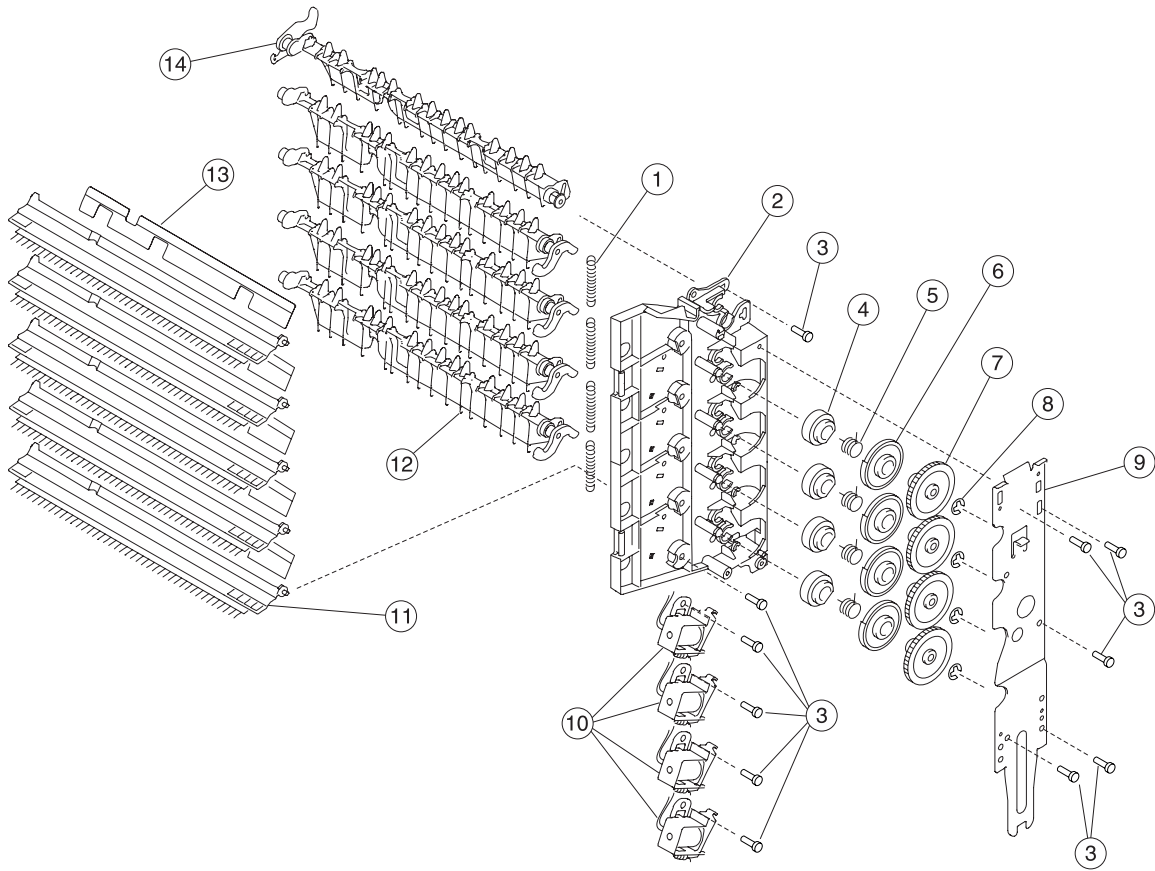

Assembly 27.1: 5-Bin Mailbox

Asm- Index	Part number	Units	Description
27.1-1	99A1741	4	Spring, diverter
2	99A1727	1	Frame asm, right side
3		12	Screw, board mounting PP 12G6309
4	99A1728	4	Cam, diverter actuator
5	99A1731	4	Spring, diverter actuator
6	99A1729	4	Latch, diverter actuator
7	99A1730	4	Arbor, diverter actuator
8	99A1789	4	C-clip
9	56P0418	1	Bracket, attach front
10	99A1732	4	Solenoid, diverter
11	99A1738	5	Deflector, paper exit w/brush
12	99A1722	4	Deflector, paper
13	99A1787	4	Deflector
14	99A1721	1	Deflector, paper top bin
NS	56P0421	1	Spring, static ground
NS	99A0462	1	Grease packet, IBM #23
NS	99A1715	1	Roller asm, rear access door
NS	99A1717	1	Gear, drive
NS	99A1788	1	Retainer, R-ring
NS	99A0450	10	Retainer
NS	56P0550	1	Cable, tray media level sensor

Assembly 28: 500-sheet drawer option

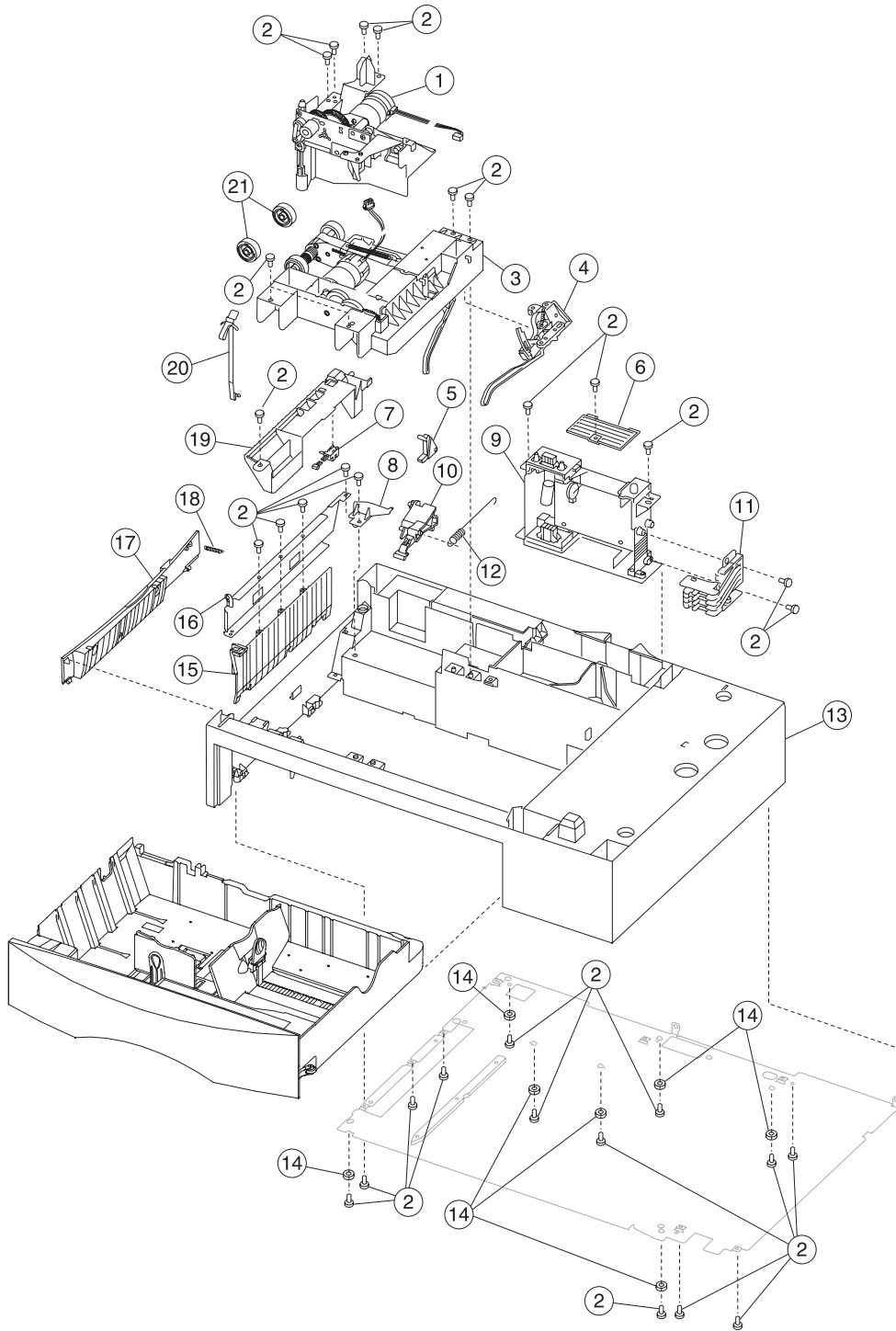

Assembly 28: 500-sheet tray option

Asm- Index	Part number	Units	Description
28-1	56P0168	1	Drive assembly, 500 option 2
2		31	Screw, PP 12G6309
3	12G6550	1	500-Sheet Option tray pick assembly
4	12G6565	1	Paper level sensing assembly
5	12G6471	1	Tray interlock bellcrank
6	12G6556	1	Cover, frame
7	12G6553	1	Pass thru sensor
8	12G6562	1	Hinge
9	12G6559	1	Electronics/size sensing assembly with system board
10	12G6558	1	Pick arm lift bellcrank
11	12G6566	1	Paper size sensing assembly
12	12G6557	1	Bellcrank lift spring
13	12G6560	1	500 base assembly
14	12G6380	7	Machine pad
15	12G6554	1	Paper guide
16	12G6563	1	Wall support plate
17	12G6552	1	Base door assembly
18	12G6561	1	Spring
19	12G6555	1	500 option deflector
20	12G6567	1	Grounding spring
21	99A0070	2	Pick roll tires
NS	12G6510	4	Cable tie

Assembly 28.1: 500-sheet tray option

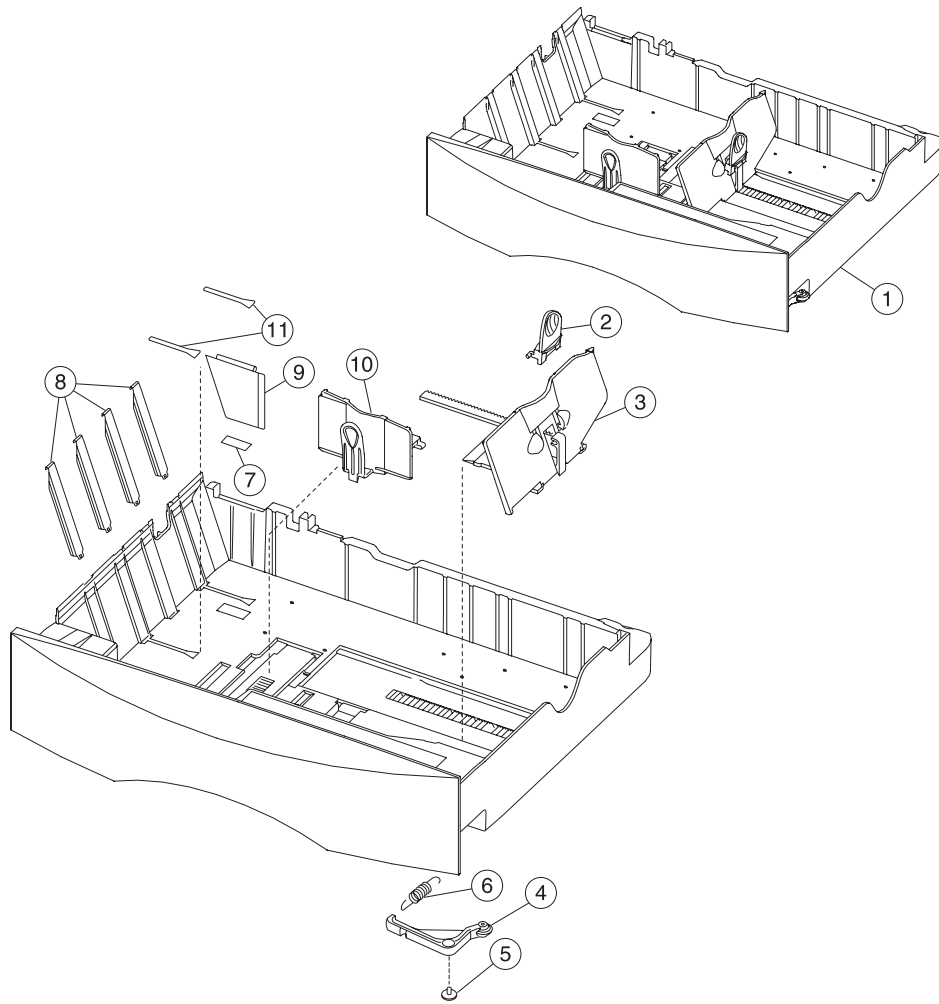

Assembly 28.1: 500-sheet tray option

Asm-Index	Part number	Units	Description
28.1-1	12G6416	1	500-Sheet tray assembly
2	12G6419	1	Back restraint latch
3	12G6418	1	Back restraint
4	12G6425	1	Tray bias bellcrank assembly
5		1	Screw, PP 12G6533
6	12G6426	1	Tray bias spring
7	12G6568	1	Reflector label
8	12G6421	1	Wear strip
9	12G6420	1	Tray wear clip
10	12G6417	1	Side restraint
11	56P1504	2	Active restraint pad

Assembly 29: Duplex option

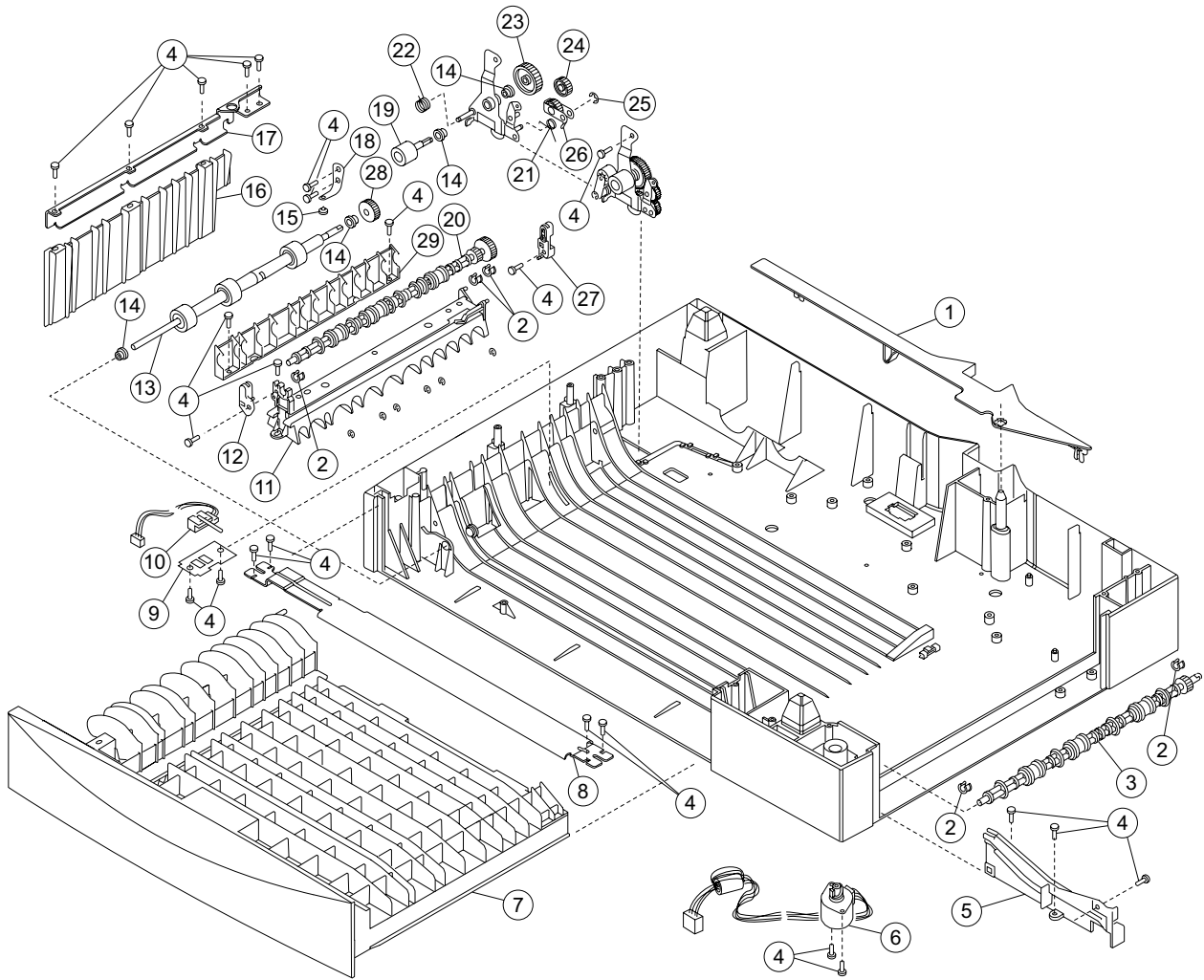

Assembly 29: Duplex option

Asm- Index	Part number	Units	Description
29-1	56P0480	1	Back cover
2	99A2540	5	Redrive bearing
3	56P0447	1	Duplex entry shaft assembly
4		20	Screw PP 12G6533
5	56P0434	1	Right side front tray guide
6	56P0483	1	Deflector actuator assembly
7	56P0432	1	Duplex front jam tray assembly
8	56P0457	1	Duplex support bracket
9	56P0455	1	Sensor mount plate
10	56P0442	1	Duplex exit sensor
11	56P0435	1	Duplex shaft mount
12	56P0479	1	Front decurl assembly
13	56P0444	1	F/R backup shaft assembly
14	56P0476	3	5 mm bushing
15	56P0473	1	Brake pad
16	56P0439	1	Duplex paper guide
17	56P0454	1	Wall support
18	56P0475	1	Brake spring
19	56P0472	1	Pass thru shaft assembly
20	56P0441	1	Duplex shaft assembly
21	56P0468	1	Pass thru spring
22	56P0470	1	Aligner arm spring
23	56P0466	1	Spur drive gear
24	56P0467	2	26T duplex gear
25	99A0267		Retainer PP 99A0267
26	56P0471	1	Bellcrank assembly
27	56P0474	1	Decurl BAC assembly
28	56P0445	1	40T shaft drive F/R gear
29	56P0449	1	Support decurl guide
NS	56P0482	1	Pulley washer

Assembly 29.1: Duplex option

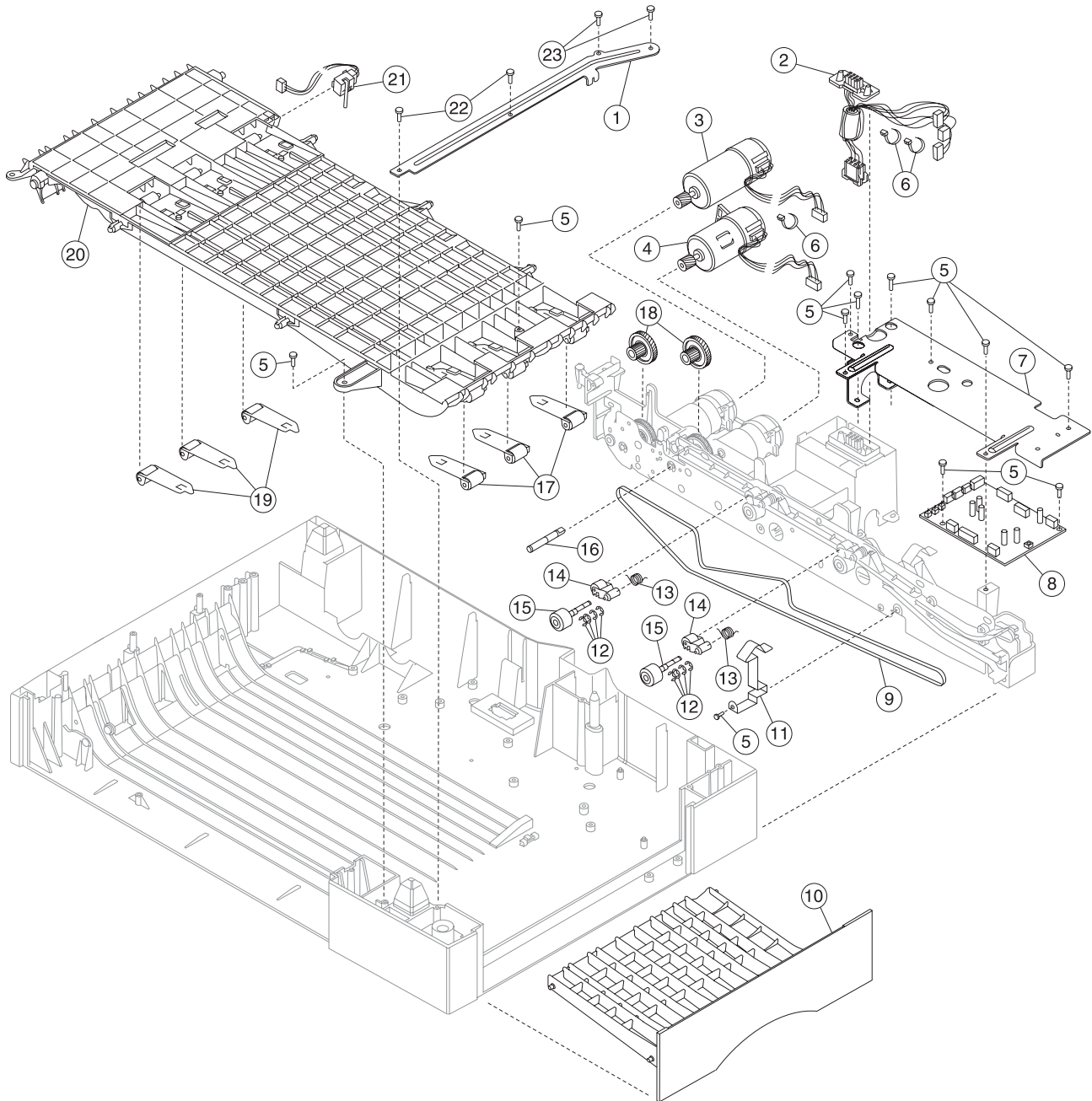

Assembly 29.1: Duplex option

Asm- Index	Part number	Units	Description
29.1-1	56P0456	1	Duplex support plate
2	56P0462	1	Autoconnect cable assembly
3	56P0463	1	DC forward/reverse motor assembly
4	56P0464	1	DC duplex feed motor
5		1	Screw PP 12G6309
6	12G6510	6	Cable Tie (6 in pack)
7	56P0459	1	Back support
8	56P0430	1	Duplex card assembly
9	56P2484	1	Belt, transfer
10	56P0433	1	Right jam clearance tray assembly
11	56P0458	1	Chassis ground spring
12	99A1789	1	Retainer, C-clip
13	56P0478	2	Aligner spring
14	99A0323	2	Paper guide assembly
15	56P0465	2	Drive alignment shaft assembly
16	56P0477	1	Reduction gear shaft
17	56P0451	3	Backup spring assembly
18	99A1717	2	32 ppm drive gear
19	56P0452	3	Backup spring assembly
20	56P0436	1	Upper rib assembly
21	56P0437	1	Duplex output sensor
22			Screw PP 12G6530
23			Screw (long)
NS	99A0323	2	Paper guide assembly

Assembly 30: High-capacity input tray (HCIT)

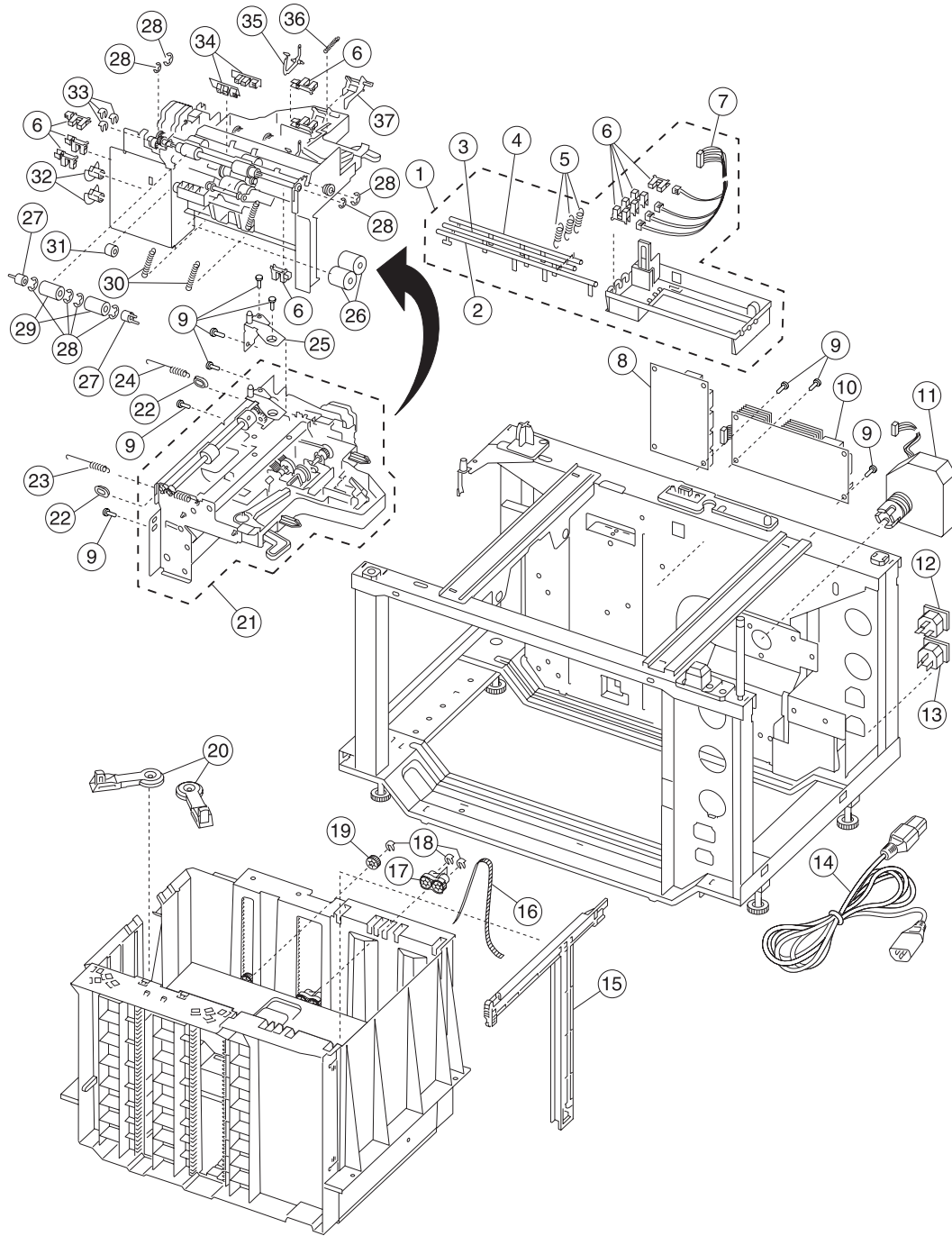

Assembly 30: High-capacity input tray (HCIT)

Asm- Index	Part number	Units	Description
30-1	56P0561	1	Paper size sensor box assembly
2	56P0519	1	Flag, paper size R
3	56P0520	1	Flag, paper size F
4	56P0518	1	Flag, paper size C
5	56P0522	3	Spring, paper size flag
6	56P0516	10	Sensor, photo interrupter
7	56P0511	1	Paper size sensors cable
8	56P0494	1	System control board
9			Screws PP 12G6533
10	56P0495	1	LVPS
11	56P0513	1	Elevator motor assembly
12	56P0497	1	AC power outlet
13	56P0498	1	AC power inlet
14	56P0490	1	Jumper, AC power cord
15	56P0524	1	Paper tray guide
16	56P0547	1	Elevator lift belt
17	56P0549	1	Elevator lift
18	56P0563	3	Ring 7, elevator lift gear/elevator lift
19	56P0548	1	Elevator lift gear
20	56P0523	2	Paper tray arms
21	56P0525	1	Feed unit, complete assembly
22	56P0527	2	Bushing
23	56P0533	1	Spring, feed unit front
24	56P0534	1	Spring, feed unit rear
25	56P0562	1	Feed cover
26	56P0542	2	Separation/torque roller
27	56P0529	2	Feed cam
28			E-clips PP 56P0531
29	56P0528	2	Feed roller
30	56P0530	2	Spring, feed unit
31	56P0532	1	Bushing, 060
32	56P0544	2	Emitter timing wheel
33	56P0535	3	Clip, plastic 5W
34	56P0526	2	Sensors, special optical
35	56P0536	1	Level sensor flag
36	56P0540	1	Spring, extension
37	56P0539	1	Near empty sensor flag

Assembly 30.1: High-capacity input tray (HCIT)

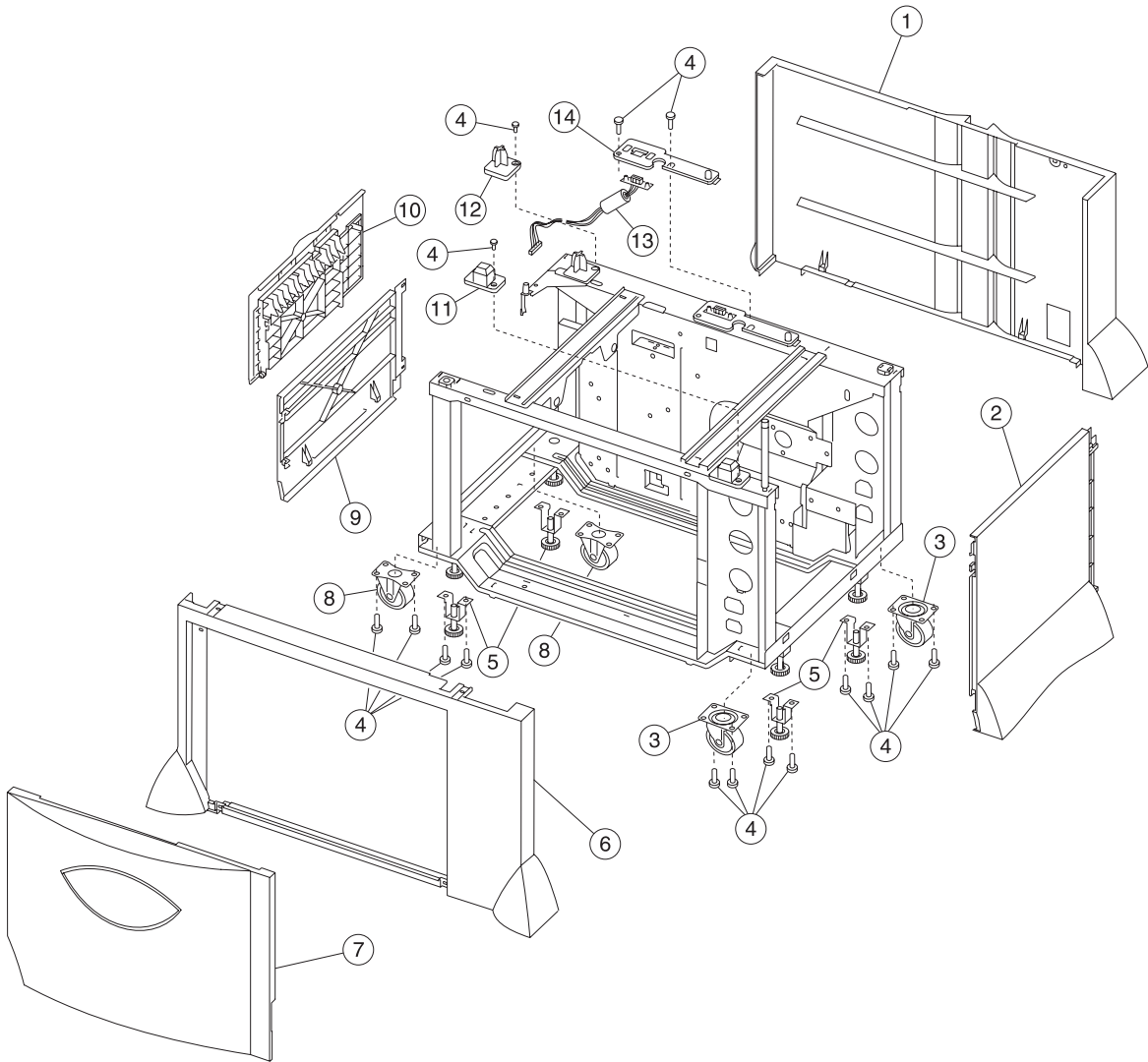

Assembly 30.1: High-capacity input tray (HCIT)

Asm- Index	Part number	Units	Description
30.1-1	56P0505	1	Rear cover
2	56P0503	1	Right side cover
3	56P0491	2	Caster, movable
4		16	Screws PP 12G6533
5	56P0493	4	F adjuster
6	56P0500	1	Front cover
7	56P0501	1	Cover, main CA
8	56P0492	2	Caster, fixed
9	56P0504	1	Left side cover
10	56P0508	1	Upper left side jam cover
11	56P0507	1	Locating pin, options front right
12	56P0506	1	Locating pin, options rear left
13	56P0514	1	Options autoconnect cable assembly
14	56P0517	1	Options cable mounting plate
NS	56P0509	1	Cable, feed unit special sensors
NS	56P0510	1	Cable, feed unit sensors
NS	56P0512	1	Cable, elevator motor
NS	56P0515	1	Magnetic latch
NS	56P0541	1	Tray present lever
NS	56P0543	9	Cable clamp
NS	56P0564	1	Kit, stabilizer with mounting screws

Assembly 31: High-capacity output finisher (HCOF)

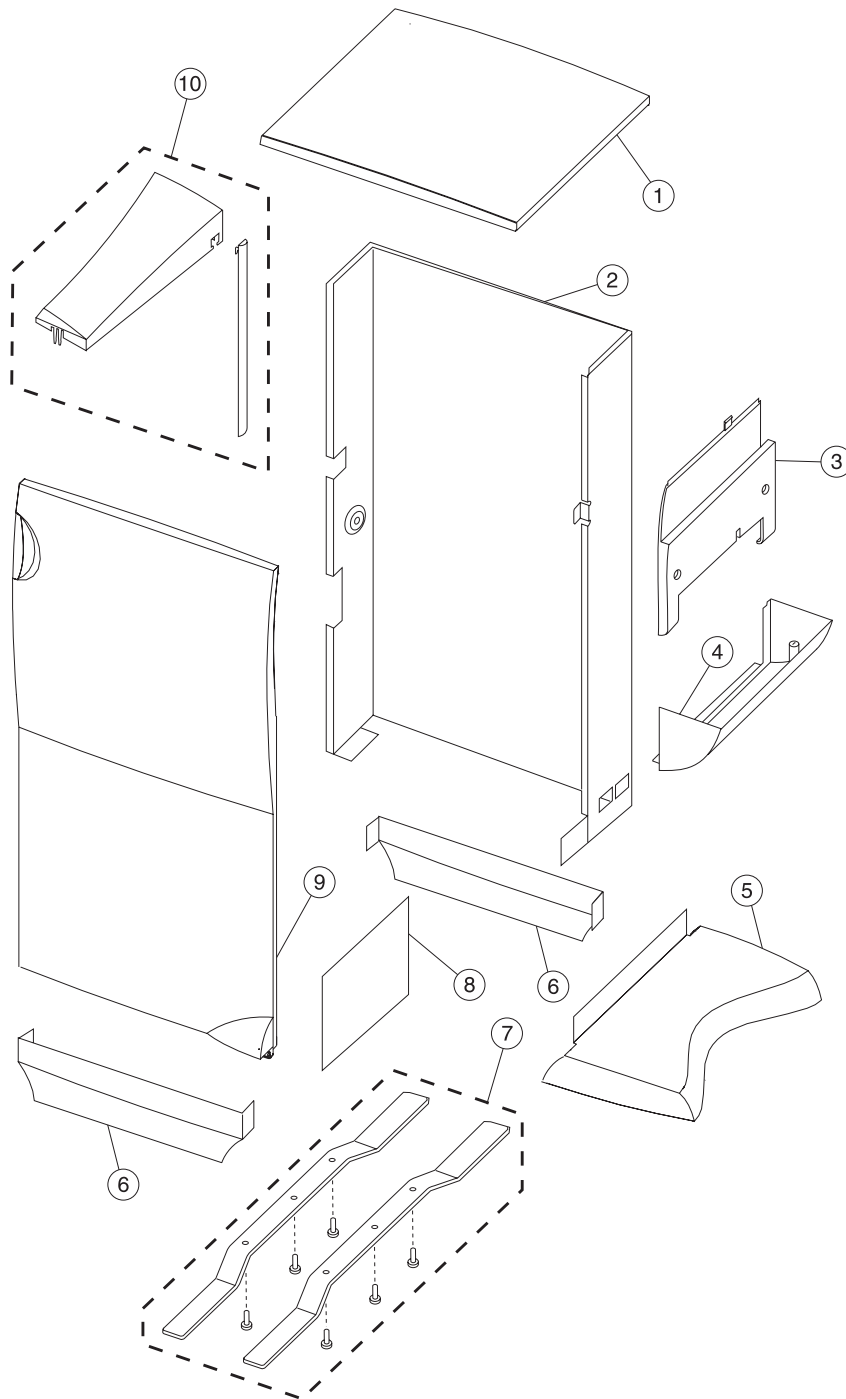

Assembly 31: High-capacity output finisher (HCOF)

Asm- Index	Part number	Units	Description
31-1	56P0321	1	Top cover (tall finisher)
1	56P1287	1	Scanner plate (short finisher)
2	56P0569	1	Rear cover
3	56P0573	1	Upper right side cover (tall finisher)
3	56P1286	1	Upper right side cover (short finisher)
4	56P0574	1	Lower tray cover
5	56P0576	1	Bottom kick cover
6	56P0575	1	Front/rear lower cover
7	56P0387	1	Bar tip unit
8	56P0577	1	Lower right side cover
9	56P0320	1	Cover front door
10	56P0566	1	Finisher install kit
11	56P1290	1	Cover wire
NS	56P0317	1	Cartridge staple

Assembly 31.1: High-capacity output finisher

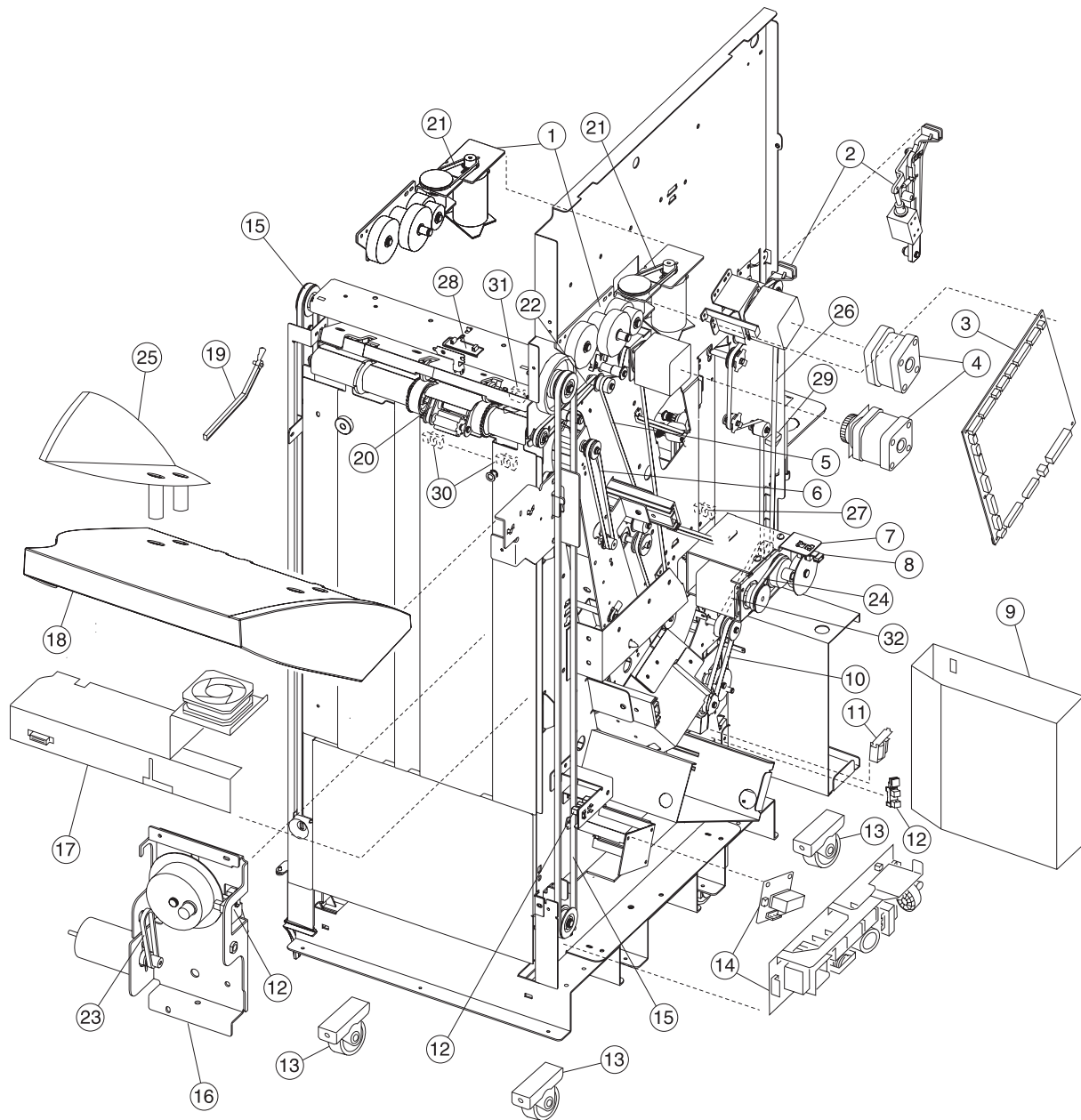

Assembly 31.1: High-capacity output finisher

Asm- Index	Part number	Units	Description
31.1-1	56P0324	1	Motor assembly elevator tray
2	56P0357	1	Actuation assembly
3	56P1471	1	HCOF control board assembly
4	56P0325	1	Motor assembly paper feed
5	56P0332	1	Accumulator paper feed belt (40S3M900)
6	56P2294	1	Accumulator drive belt (B30S2M334)
7	56P0315	1	Punch assembly
8	56P0345	1	Punch motor homing sensor (GP1A73A)
9	56P0318	1	Box chad
10	56P0329	1	Inverter D drive belt (40S3M225)
11	56P0383	1	Solenoid inverter
12	56P0347	3	Inverter jam/tray near full/output tray offset sensor (EE-SX1235A-P2)
13	56P0342	4	Caster
14	56P0338	1	Low voltage power supply
15	56P0333	2	Tray elevator belt (60S6M1420)
16	56P0323	1	Output tray offset motor and gear assembly
17	56P0386	1	Fan assembly DC motor
18	56P0322	1	Tray paper
19	56P0326	1	Flag paper full
20	56P0331	1	Exit foam Roller drive belt (40S3M80)
21	56P0334	1	Tray elevator drive belt (170P2M4)
22	56P0335	1	Exit roller drive belt (40S2M264)
23	56P0336	1	Output tray offset drive belt (40S2M134)
24	56P0337	1	Punch belt (40S2M176)
25	56P0578	1	Tray wall cover
26	56P0327	1	Paper feed belt (40S3M888)
27	56P0343	1	Punch timing sensor (OJ-541-A5)
28	56P0350	2	Paper surface sensor (EE-SX460-P1-CHN)
29	56P0352	1	Printer docking switch SS-5FL-3T(10E)
30	56P0388	1	Tray limit switches (includes two)
31	56P0346	1	Exit timing sensor (EE-SPY415)
32	56P0328	1	Inverter transfer belt (40S3M198)
NS	56P0340	1	Cable, communications
NS	56P0341	1	Power cord
NS	56P0354	1	Bracket finisher alignment
NS	56P0356	1	Pack magnet, strong and weak and door latch

Assembly 31.2: High-capacity output finisher

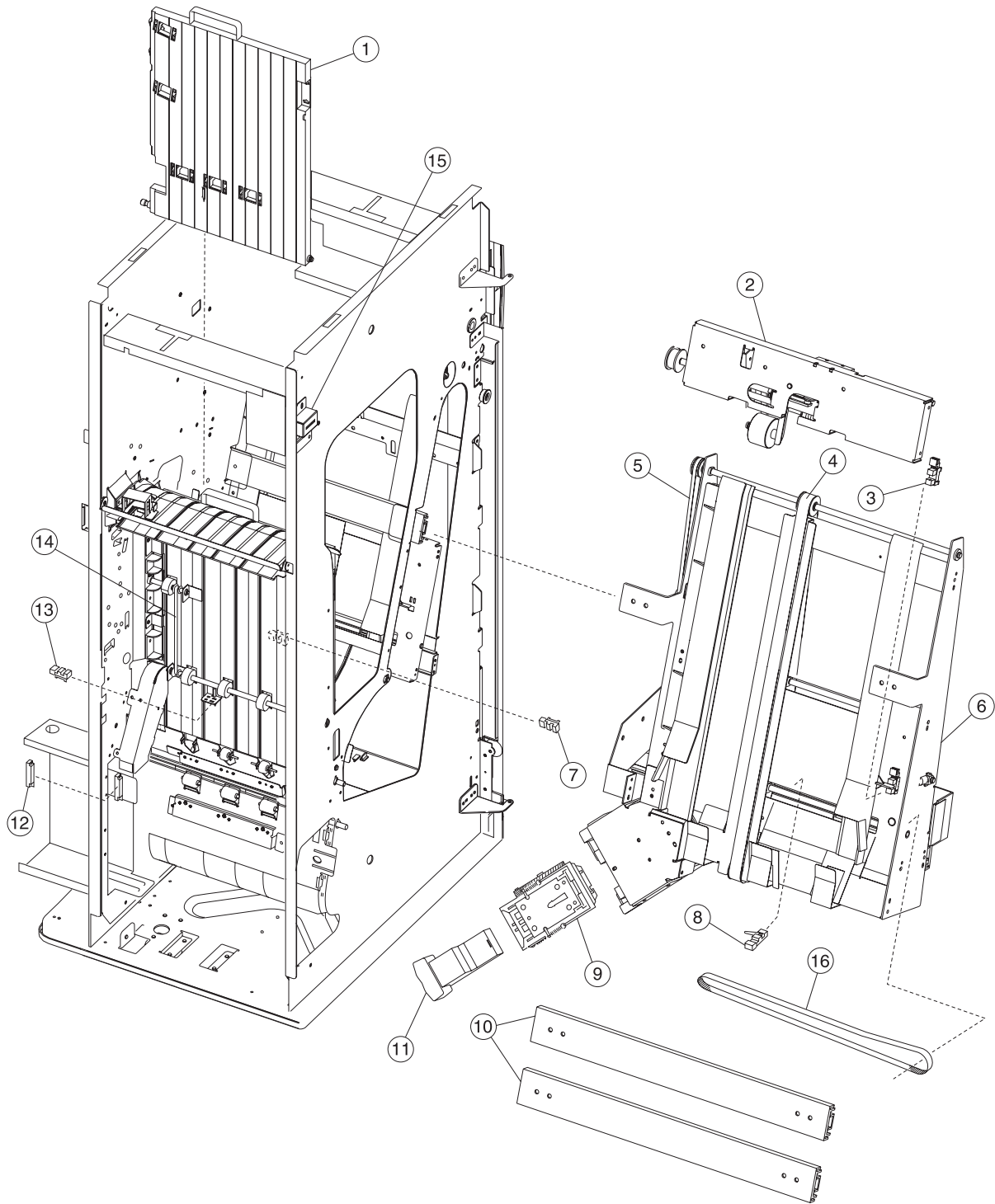

Assembly 31.2: High-capacity output finisher

Asm- Index	Part number	Units	Description
31.2-1	56P0355	1	Guide vertical paper
2	56P0385	1	Solenoid drop assembly
3	56P0347	1	Jogger fence homing sensor (EE-SX1235A-P2)
4	56P0384	1	Accumulator belt (hook)
5	56P2294	1	Accumulator drive belt (B30S2M334)
6	56P0319	1	Accumulator w/o stapler
7	56P0348	1	Drop timing sensor (OS-535223-602)
8	56P0349	1	Accumulator homing sensor (OS-311D-A5)
9	56P0316	1	Staple assembly
10	56P0358	2	Accumulator slides
11	56P0317	1	Staple cartridge
12	56P0346	1	Chad box full sensor (EE-SPY415)
13	56P0344	1	Inverter timing sensor (OJ511K-A5)
14	56P0330	1	Paper feed-input belt (40S3M279)
15	56P0351	1	Cover open switch
16	56P2295	1	Jogger fence belt (B40S2M460)
NS	56P0382	1	Harness cable assembly D5 - low voltage power supply to low voltage power relay board

Assembly 32: High-capacity output finisher cables

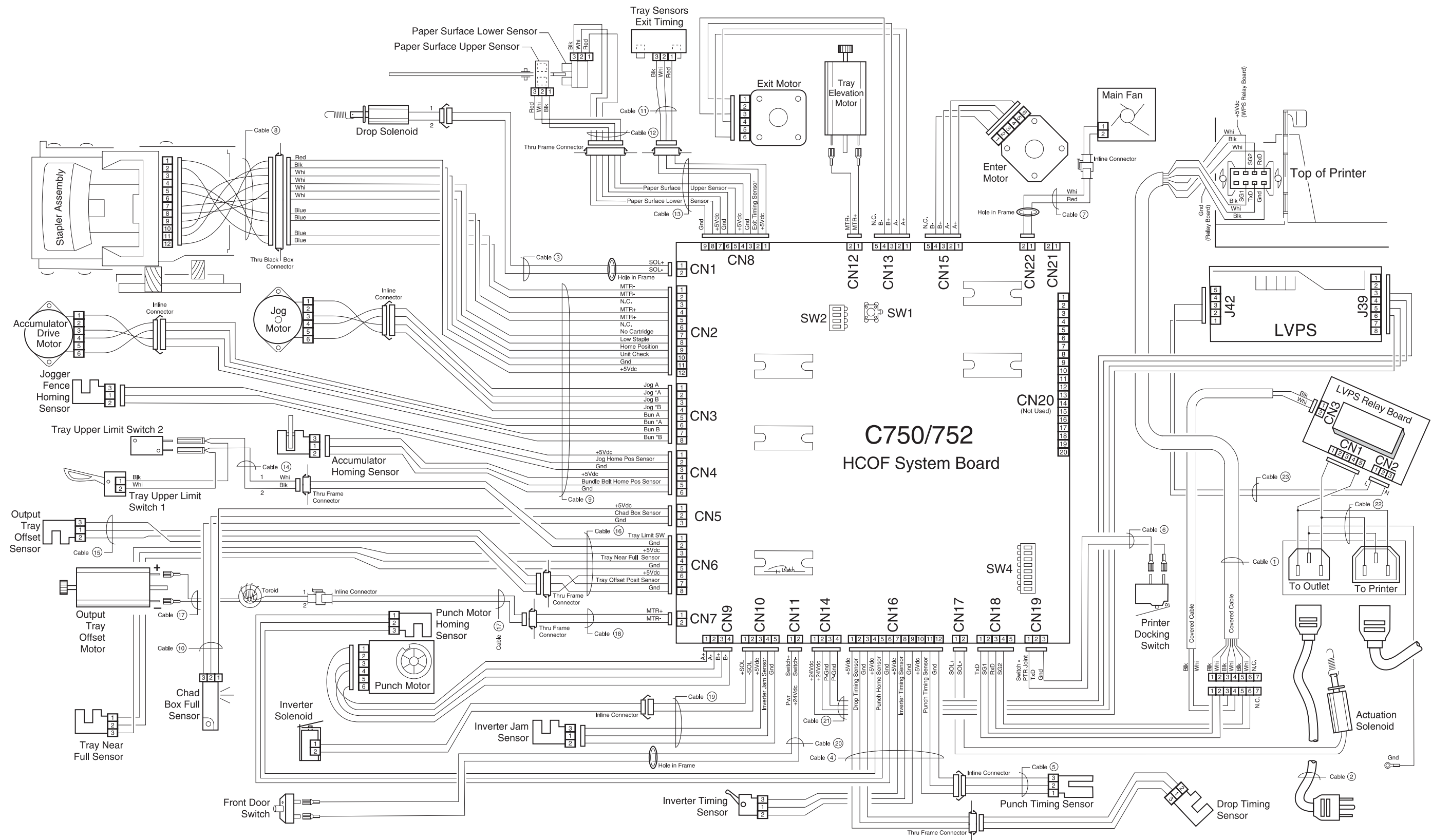

Assembly 32: High-capacity output finisher cables

Asm- Index	Part number	Units	Description
32-1	56P0340	1	Cable, communications
2	56P0341	1	Power cord
3	56P0359	1	Harness cable assembly H2 - system board to drop solenoid
4	56P0360	1	Harness cable assembly H3 - system board to harness cable assembly H4/drop timing sensor/punch motor homing sensor/inverter timing sensor
5	56P0361	1	Harness cable assembly H4 - harness cable H3 to punch timing sensor
6	56P0362	1	Harness cable assembly H5 - system board to printer docking switch
7	56P0363	1	Harness cable assembly H6 - system board to fan
8	56P0364	1	Harness cable assembly S1 - stapler cable to stapler assembly
9	56P1280	1	Harness cable assembly stapler - system board to cable S1/jogger fence homing sensor/accumulator homing sensor/jogger motor accumulator drive motor
10	56P0368	1	Harness cable assembly S5 - system board to chad box full sensor
11	56P0369	1	Harness cable assembly E2 - cable E5 to exit timing sensor
12	56P0370	1	Harness cable assembly E3 - cable E5 to paper surface upper sensor/paper surface lower sensor
13	56P0371	1	Harness cable assembly E5 - system board to cable E2/E3
14	56P0372	1	Harness cable assembly E6 - cable E8 to tray limit switches
15	56P0373	1	Harness cable assembly E7 - cable E8 to output tray offset sensor
16	56P0374	1	Harness cable assembly E8 - system board to E6/E7
17	56P0375	1	Harness cable assembly E9 - cable E10 to output offset motor
18	56P0376	1	Harness cable assembly E10 - system board to cable E9
19	56P0378	1	Harness cable assembly R1 - system board to inverter solenoid/inverter jam sensor
20	56P0379	1	Harness cable assembly D1 - system board to front door switch
21	56P0380	1	Harness cable assembly D2 - system board to low voltage power supply
22	56P0381	1	Harness cable assembly D3 - low voltage power supply relay board to AC input/output
23	56P0382	1	Harness cable assembly D5 - low voltage power supply to low voltage power supply relay board.

Assembly 33: Options

Asm-Index	Part number	Units	Description
NS	56P9909	1	Card assembly, PRESCRIBE
NS	12G6509	1	Card assembly, 64MB SDRAM
NS	56P9910	1	Card assembly, 128MB SDRAM
NS	56P9911	1	Card assembly, 256MB SDRAM
NS	56P9912	1	Card assembly, 4MB flash DIMM
NS	56P9913	1	Card assembly, 8MB flash DIMM
NS	56P9914	1	Card assembly, 16MB flash DIMM
NS	56P2107	1	Card assembly IPDS/SCS/Tne
NS	56P1120	1	Card assembly, Bar code
NS	56P1461	1	Card assembly, ImageQuick™
NS	56P9935	1	Card assembly, Traditional Chinese font DIMM
NS	56P9936	1	Card assembly, Simplified Chinese Font DIMM
NS	56P9975	1	Card assembly, Japanese font DIMM
NS	56P0162	1	Adapter, parallel 1284 C-B
NS	56P9982	1	Hard disk, 20GB with/adapter (formatted)
NS	56P9926	1	Lexmark Optra Forms™ software
NS	56P9927	1	Lexmark Forms Director software
NS	56P9928	1	Lexmark Forms 4MB flash DIMM
NS	56P9929	1	Lexmark Forms 8MB flash DIMM
NS	56P9930	1	Lexmark Forms 16MBMB flash DIMM
NS	56P9932	1	Hard disk, Lexmark Forms
NS	56P9942	1	Hard drive mounting kit
NS	56P9934	1	MarkNet™ Token-Ring Print Server
NS	12G1695	1	MarkNet N2001e Ethernet 10/100BaseTX
NS	12G1696	1	MarkNet N2002e Ethernet 10BaseT/2
NS	56P1431	1	MarkNet X2011e Ethernet 10/100 BaseTX-1 port
NS	56P1432	1	MarkNet X2012e Ethernet 10/100 BaseTX/10 Base2 - 1 port
NS	56P1433	1	MarkNet X2031e Ethernet 10/100 Base TX - 3 port
NS	56P1434	1	MarkNet X2030e Token-Ring - 3 port
NS	99A0545	1	External serial adapter
NS	99A0560	1	Tri-Port Adapter - LocalTalk/serial/infrared
NS	99A0629	1	Coax/Twinax Adapter for SCS
NS	99A0424	1	Infrared adapter
NS	56P0161	1	RS-232-C serial/parallel 1284-C adapter
NS	99A0923	1	Parallel port + USB INA card assembly

Assembly 34: Miscellaneous

Asm-Index	Part number	Units	Description
NS		1	Screw type 323, PP 12G6309
NS		1	Screw type 324, PP 12G6530
NS		1	Screw type 232, PP 12G6531
NS		1	Screw type 102, PP 12G6532
NS		1	Screw type 312/322/412/423, PP 12G6533
NS		1	Screw type 484, PP 12G6534
NS		1	Screw, 500-sheet tray, PP 12G6538
NS		1	Screw type 124, PP 12G6539
NS		1	Screw type 121, PP 12G6540
NS	7370235	1	Kit, relocation package assembly printer
NS	7370563	1	Kit, relocation package assembly Output Expander
NS	7370564	1	Kit, relocation package assembly 5-Bin Mailbox
NS	7370565	1	Kit, relocation package assembly 500 Drawer
NS	7370566	1	Kit, relocation package assembly Duplex
NS	7370595	1	Kit, relocation package assembly Finisher

Appendix A—Service tips

Printhead diagnostics

If you get a printhead error, follow this diagnostic to find the specific failure.

1. Verify that all the printhead cables are properly seated.
If the printhead cables are properly seated and the error remains, record the error code. Continue to the next step.
2. Determine how to setup the printhead diagnostic tool.
 - a. If the printhead diagnostic tool is not configured as in the illustration below, reconfigure it to match.

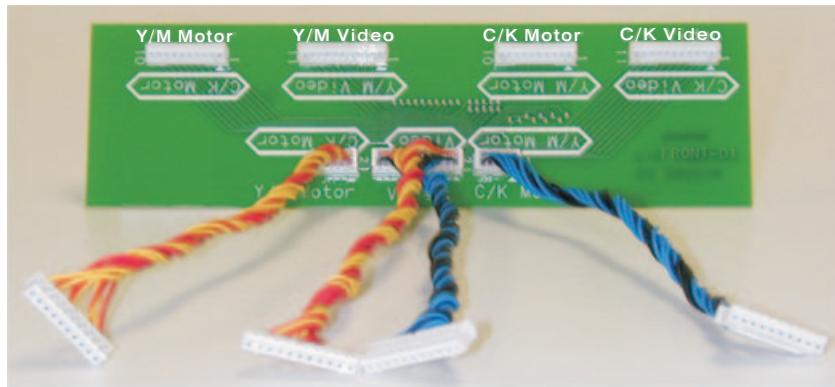

- b. Select which pair of printheads to switch based on the error code.
If the printer displays the codes that indicate yellow or cyan, use the tool to switch the yellow and cyan signals. If the error code indicates a magenta or black error, use the tool to switch the magenta and black signals.

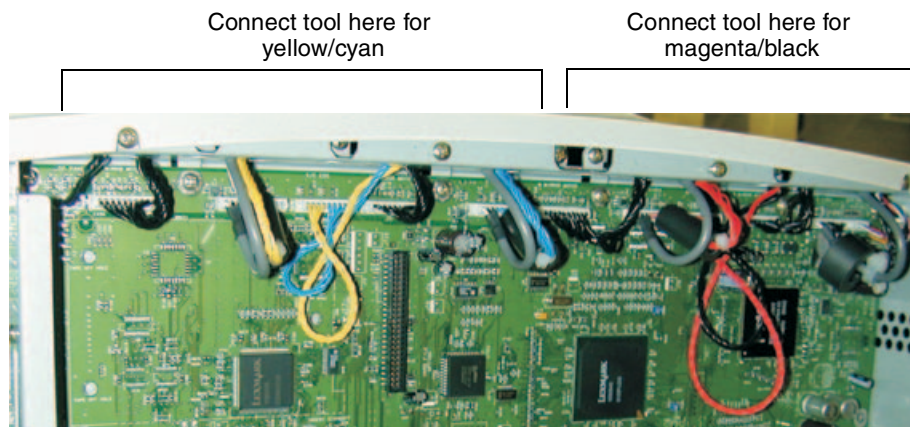

3. Install the printhead diagnostic tool and determine the problem.
The following procedure shows the yellow and cyan switch as an example.
 - a. Turn off the printer.
 - b. Unplug the printhead cables from the RIP board in the printer and connect them to the printhead diagnostic tool.

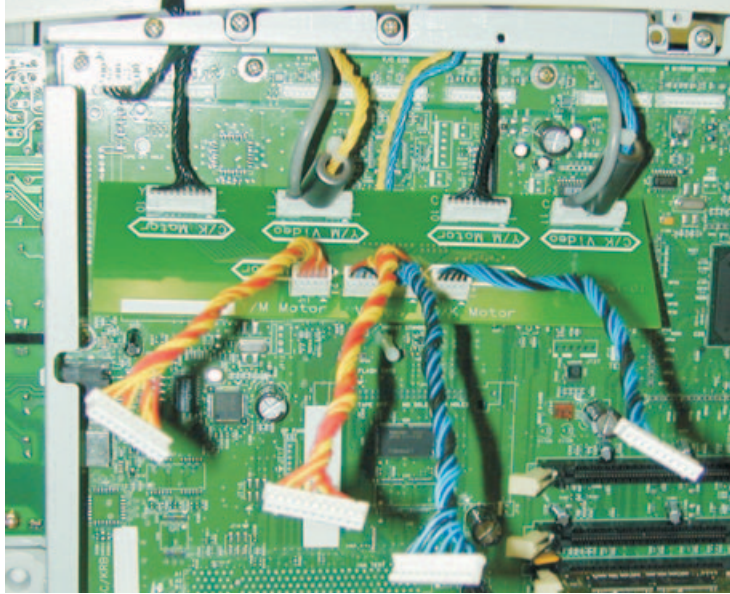

- c. Connect the printhead diagnostic tool cables to the connectors on the RIP board in the printer. This reverses the printhead color signals for the selected pair of colors.

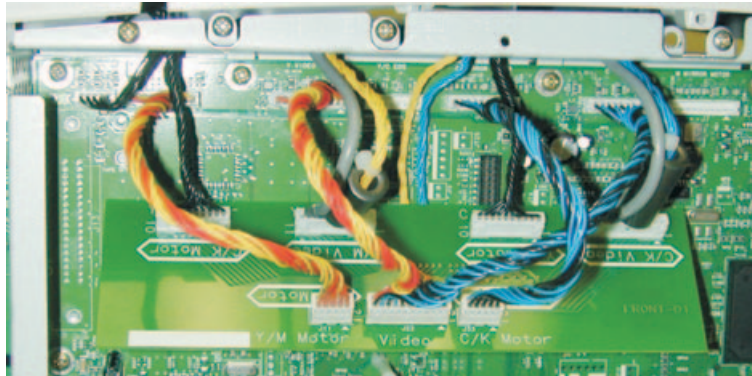

- d. Turn on the printer and note the new error codes.
- If an automatic calibration begins, **36 Printer Service Required** may appear. The printhead and RIP board are working correctly and the printhead cable connections should be checked. Press **Go** to clear the error.
 - If the error code remains the same, replace the RIP board. If that solves the problem, you are finished.
 - If the printer displays a different printhead error code, which indicates another color, the printhead or the printhead cables are defective. See the table below for printhead codes.
- For example, the printer originally displays the printhead error code **108** (yellow). After switching the signals using the diagnostic tool, the printer displays the printhead error code **106** (cyan).

	Printhead error codes		Printhead error codes	
	Yellow	Cyan	Magenta	Black (K)
For 10x errors	108	106	107	109
For 11x errors	117	115	116	114
For errors 169–175	175	171	173	169
Not commonly seen	176	172	174	170

4. Remove the printhead diagnostic tool.
5. The problem is in either the printhead cables or the printhead. Replace the printhead cables. If the problem remains, replace the printhead.
6. Perform the printhead adjustments.

Printhead alignment

Identifying the printheads

	Black (K)	Magenta (M)	Cyan (C)	Yellow (Y)
Printhead error codes	109	107	106	108
	114	116	115	117
	169	173	171	175
	170	174	172	176

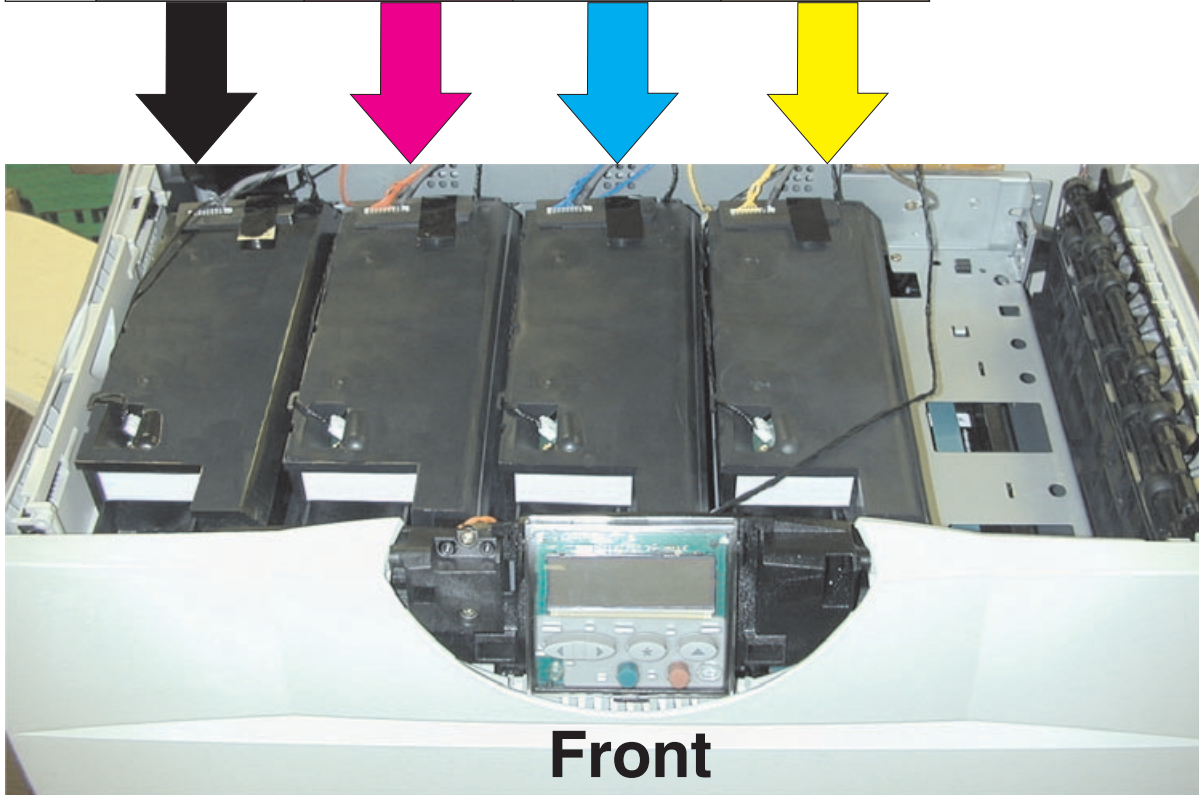

Warnings:

- Do not loosen or replace more than one printhead at a time to retain factory settings.
- Whenever a printhead is replaced, you must perform the **“Printhead mechanical alignment”** on **appendix page A-5** and **“Electronic color alignment”** on **appendix page A-12**.
- The front cover must be installed and closed before any printhead alignment can be performed. It is not necessary to remove the front cover to access the printheads.
- If there is a protective lens cover on the new printhead, it must be removed before installing the replacement printhead.

Printhead mechanical alignment

1. Identify the configuration of your printer. The following steps are similar for both versions, except you need to remove two extra screws when you have the PSD bracket.
You may have a PSD bracket (A), whether or not the PSD or thermistor is connected.

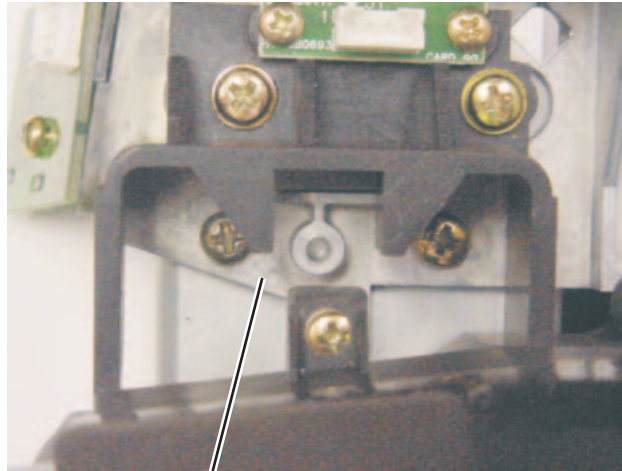

A

You may not have a bracket.

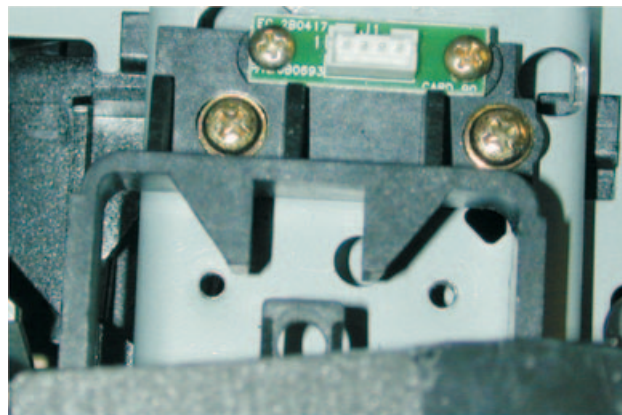

2. Insert the first printhead alignment tool.
 - a. If you have a PSD bracket, remove the two screws (A and B).
Note: Use a small diameter Phillips screwdriver to remove screw (A).

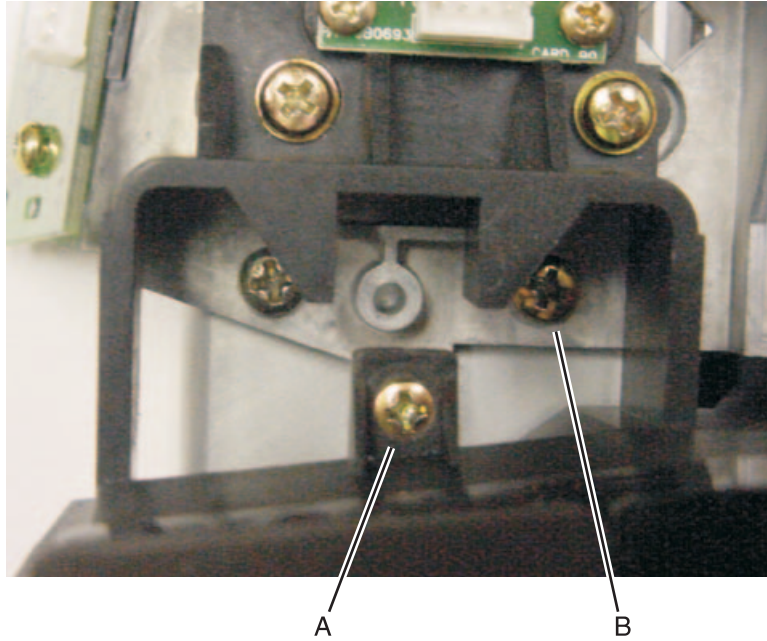

- b. Insert the printhead alignment tool, placing the locating pin (C) in the middle hole (A).
 - c. Secure the alignment tool bracket (D) with screw provided or a screw removed from the previous step.

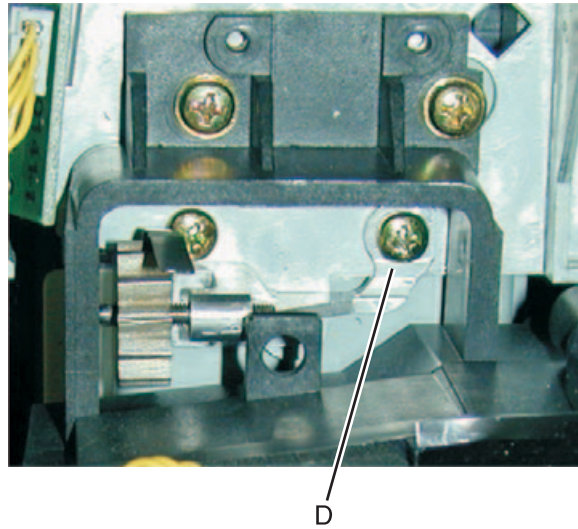
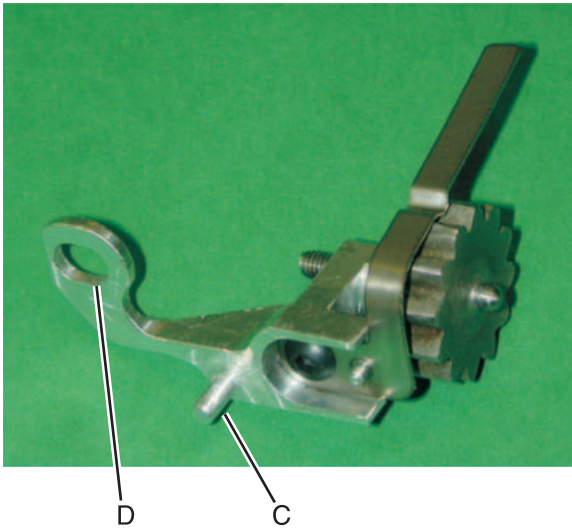

3. Install the second printhead alignment tool in the front of the printhead and secure alignment tool bracket (D) with screw provided.
Note: Align the locating pin (C) in the hole in printer frame.

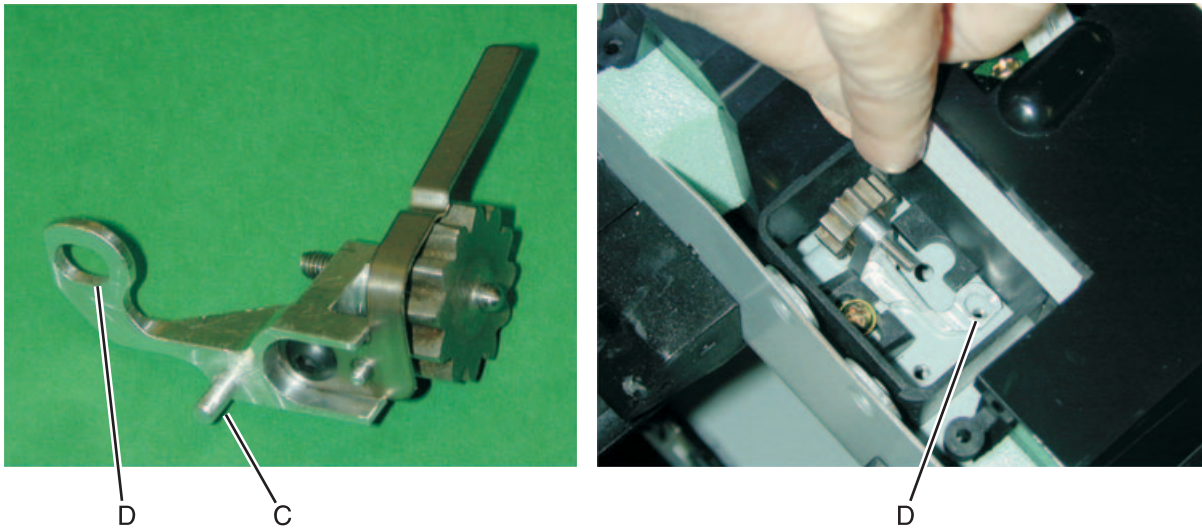

4. Turn the thumbwheel (E) until the end of the thumbwheel just touches the printhead mounting arm for both the front and rear alignment assemblies.

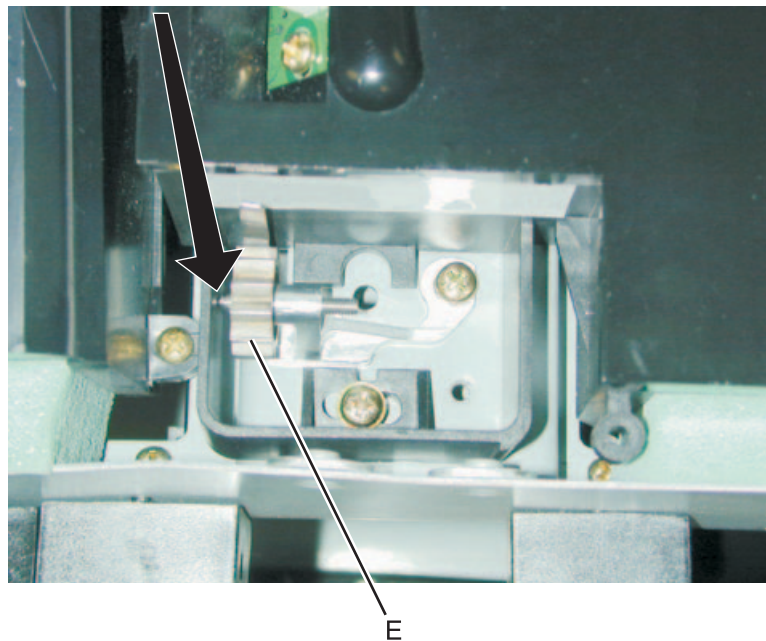

5. Remove the old printhead and install a new printhead assembly. Do not tighten the printhead screws yet.
Note: Make sure the right rear screw goes through the printhead spacer located at the right rear of the printer frame.

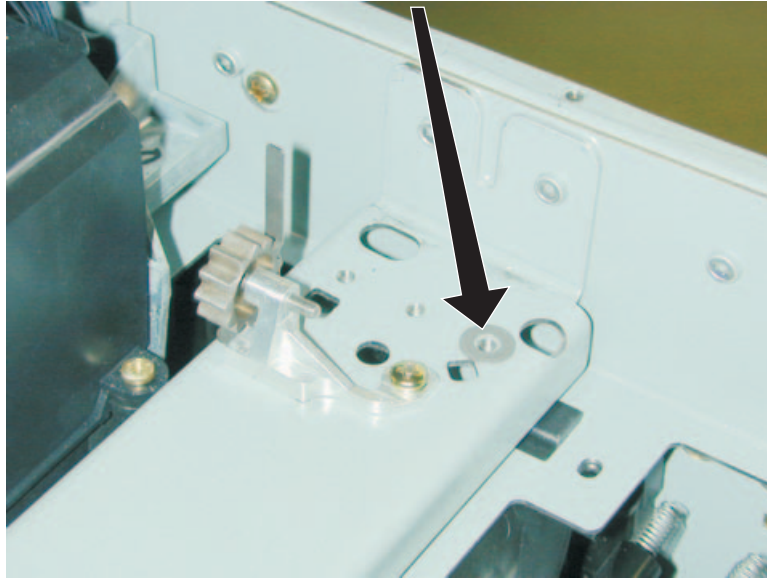

6. Bias the new printhead assembly against the front and rear stops.
7. Tighten the right rear printhead mounting screw. Then, tighten the front screw followed by the left rear screw. Make sure the printhead is biased against both the thumbwheels when tightening the screws.

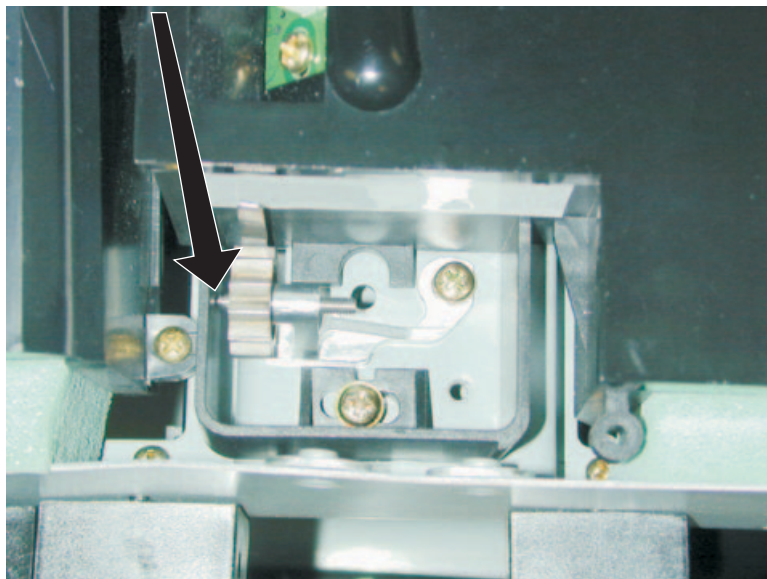

8. Securely close the front cover or reattach if previously removed.
9. If replacing the black printhead, go to step 12. Otherwise, enter Diagnostics Mode:
 - a. Turn the printer off.
 - b. Press and hold **Go** and **Return**.
 - c. Turn the printer on.
 - d. Release the buttons when *Performing Self Test* displays.
10. Select **Alignment Menu**, select the color of the printhead that was replaced, and set the Z value to zero. Exit the Diagnostics Menu
11. With the printer at *Ready* prompt, hook up a computer through the USB, network, or parallel connection and send the file, PHALIGN6.FLS, from the enclosed CD to the printer.

Note: Lay the printed Printhead Mechanical Alignment Test Page across the printheads in this orientation as a reference. Use the magnifier lens included in the FRU to view the scales at the ends of the color lines.

Printhead Mechanical Alignment Test Page

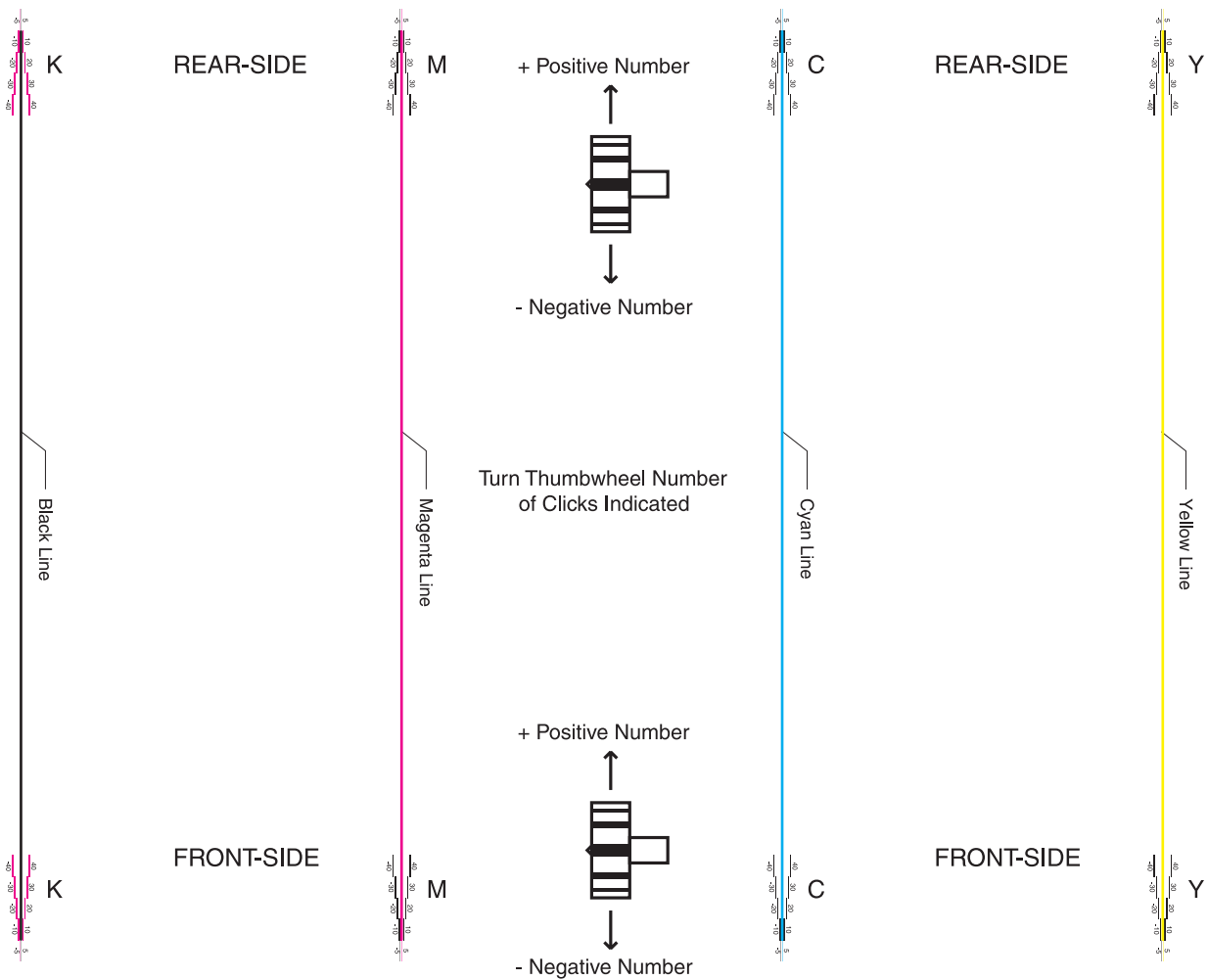

12. Loosen the printhead screws before making any adjustments to the thumbwheel.

13. Turn each thumbwheel the appropriate number of *clicks* as indicated by the test page.

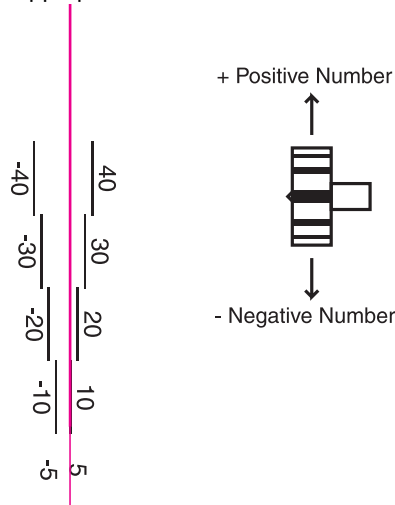

For example, if the test page indicates a +10 as the misalignment, turn the thumbwheel 10 *clicks* in the positive direction indicated on the test page. Do this for both the front and rear.

- Bias the printhead against both thumbwheels, and hold in place when tightening the printhead mounting screws.
 - Tighten the right rear printhead mounting screw. Then tighten the front screw followed by the left rear screw.
14. Send the file PHALIGN6.FLS (Printhead Mechanical Alignment Test Page) from the CD to the printer to verify printhead alignment.
15. If the printhead alignment is within ± 5 for both front and rear positions, then proceed to electronic adjustment procedure. If not, repeat steps 12 through 15, until alignment is within ± 5 .
If you are replacing the black printhead, make sure on the test page that black is within ± 5 and also within ± 1 between the front and rear side. For example, if the rear looks like it is at +3, then the front should be between +2 and +4.
- Note:** When replacing the black printhead there is no Z value to reset. After the black printhead is mechanically aligned to the magenta printhead, it will be necessary to electronically align the three color printheads to the new black printhead.

Printer registration (only for black printhead replacement)

To perform the registration and alignment through the Diagnostics Menu:

1. Enter Diagnostics Mode.
 - a. Turn the printer off.
 - b. Press and hold **Go** and **Return**.
 - c. Turn the printer on.
 - d. Release the buttons when Performing Self Test displays.
2. Select **Registration** from the menu.
Four margin offset settings are displayed.

T= sxx	B=sxx
L= sxx	R=sxx

Where xx is the current value and s is the sign (+ or -)

3. Press **Go** to print the Quick Test Page.

Examine the registration marks on the top, bottom, left, and right sides on the page.

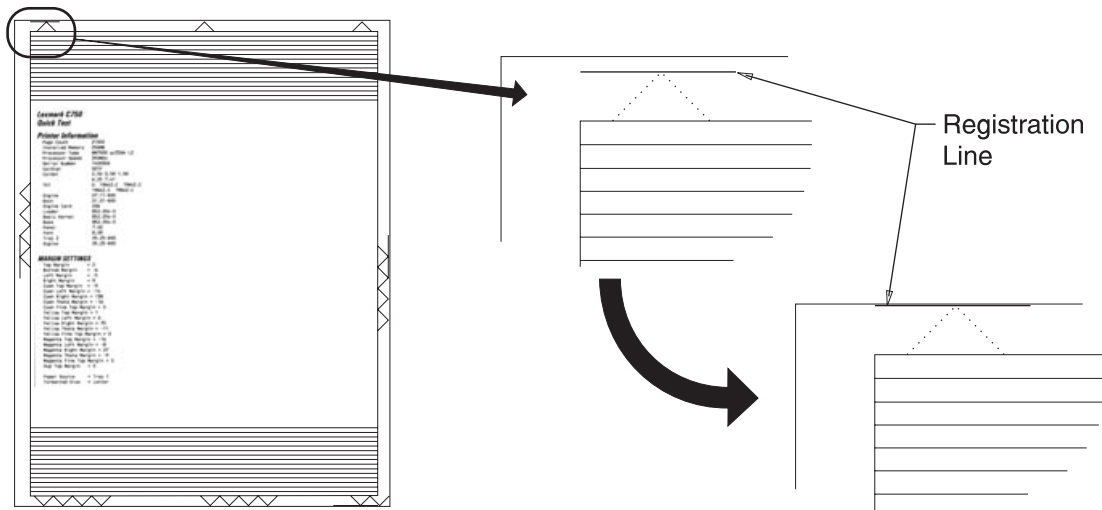

4. Adjust the margin settings so that the Registration lines are on the edge of the page. Repeat for each margin.

- Adjust the top margin before bottom margin, and the right margin before the left.

Value	Description	Value change effect:	Range
T	Top margin	Increasing the value moves the color plane down the page	-25 to +25
L	Left margin	Increasing the value moves the color plane to the left	-25 to +25
R	Right margin	Increasing the value moves the color plane to the left	-12 to +12
B	Bottom margin	Increasing the value moves the color plane down the page	-12 to +12

- **Menu** changes the values.
- **Select** saves the new value chosen and moves to the next margin setting.
- Press **Go** to print the Quick Test Page after adjusting the margins and saving the change (**Select**).

5. After completing the registration, press **Return** to exit the registration function.

Electronic color alignment

Note: Use of a loupe or magnifying glass (4x or higher) may make observation of the alignment targets easier.

1. Press **Menu** until **Alignment** displays and press **Select**.

2. Select **Alignment Test** from the Alignment menu.

Three sheets print for Cyan, Magenta, and Yellow. Each is compared to Black alignment.

For example, one of the sheets shows Cyan printed over a Black target. Align the Cyan over the Black.

Repeat for each of the colors Cyan, Magenta, and Yellow.

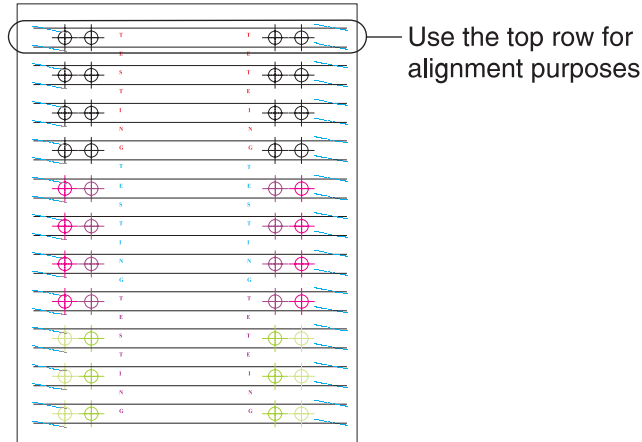

3. To align Cyan, press **Menu** until Cyan is displayed, press **Select**. Four alignment settings are displayed.

T= Top	L= Left
R= Right	Z= Theta

- **Menu** changes the values.
- **Select** saves the new value chosen and moves to the next margin setting.
- Press **Go** to print the individual color Alignment Page after adjusting the targets and saving the change (**Select**).
- The range of values differs for the various margin offsets.

Value	Description	Range
T	Top Margin Offset	-128 to +127
L	Left Margin Offset	-300 to +300
R	Right Margin Offset	-300 to +300
Z	Theta Offset (Skew compensation)	-16 to +16

4. Press **Go** to print the Cyan Alignment Page. Use the top row to determine adjustments.
- a. Use the leftmost target in the first row to adjust the Cyan and Black horizontal lines in the target (T value or Top).

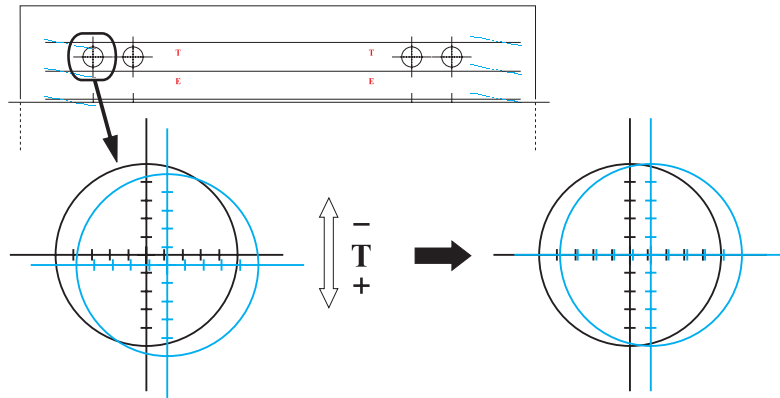

Adjust the setting and press **Go** to print the page and verify the setting, until the lines are even. Press **Select** to save the value. The display advances to the next value.

- b. To adjust Z or theta value. Press **Go** to print the Cyan Alignment Page. Use the rightmost target in the first row to adjust the Cyan and Black horizontal lines.

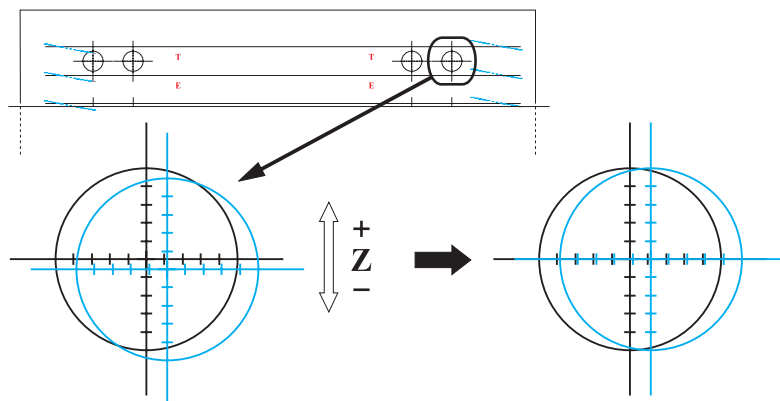

Adjust the setting and press **Go** to print the page and verify the setting, until the lines are even. Press **Select** to save the value.

- c. To adjust R or Right value press **Go** to print the Cyan Alignment Page. Use the rightmost target in the first row to adjust the Cyan and Black vertical lines.

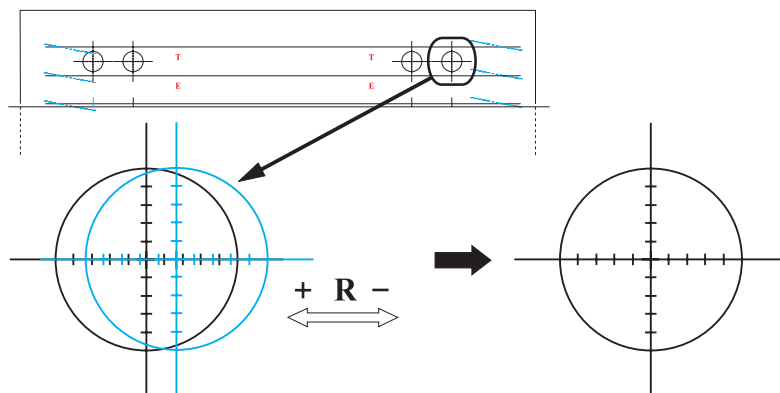

Adjust the setting and press **Go** to print the page and verify the setting, until the lines are even. Press **Select** to save the value.

- d. To adjust L or Left value, press **Go** to print the Cyan Alignment Page. Use the leftmost target in the first row to adjust the Cyan and Black vertical lines until the targets overlap.

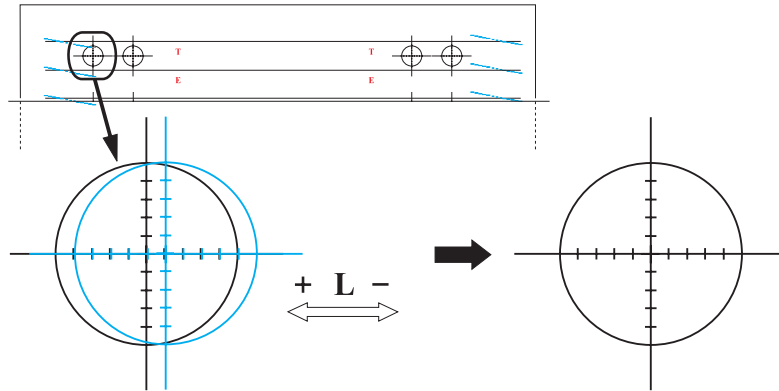

Adjust the setting and press **Go** to print the page and verify the setting, until the lines are even. Press **Select** to save the value.

- e. Change each of the settings (Top, Left, Right, and Theta) for Cyan. When the targets are aligned, press **Go** to print the final page.
5. After aligning the Cyan targets, press **Return**. Repeat the process to align the Top, Left, Right, Theta for Magenta and for Yellow.

Print line length calibration

1. Press **Return** until you reach the main Diagnostic Menu (the top line is blank and bottom line displays Alignment).
2. Press **Menu** until Print Tests is displayed and press **Select**.
3. Select **Prt Line Len Cal**.
There are six alignment groups, A through F.

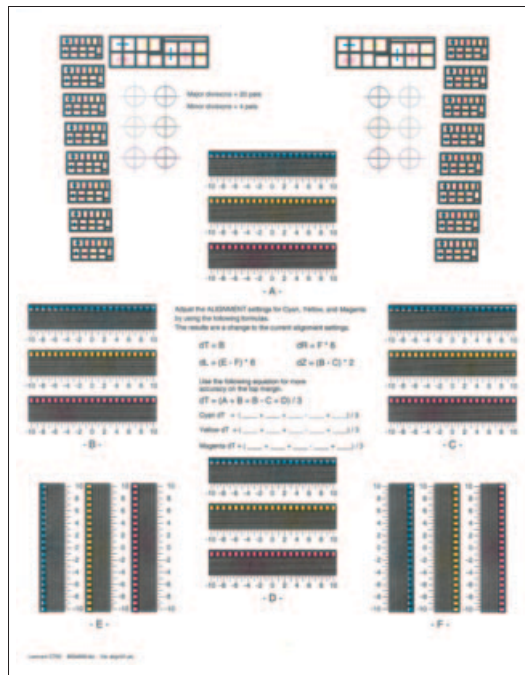

4. A color band is visible through the black bars. Locate the center of the color band and determine the value.

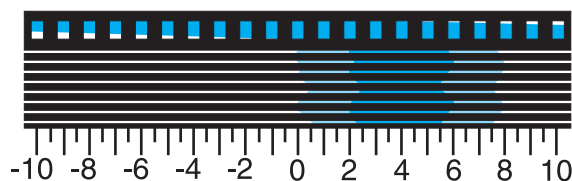

- If all the color bands for Cyan, Magenta, and Yellow on all six groups A through F are centered between -2 and +2, you are done.
 - If the center is located outside the area between -2 and +2, you need to calculate the appropriate alignment adjustment for that color. Continue to the next step.
5. Calculate the Alignment Group values.

Alignment Group	Adjustment Calculation(s)	
A	$dT=(A+B+B-C+D)/3$	---
B or C	$dT=(A+B+B-C+D)/3$	$dZ=(B-C)*2$
D	$dT=(A+B+B-C+D)/3$	---
E	$dL=(E-F)*6$	---
F	$dL=(E-F)*6$	$dR=F*6$

6. After completing calculations for the colors that are beyond -2 and +2 range, return to the Alignment menu. See **“Electronic color alignment” on page -12.**
7. Select the appropriate color.
8. Change value of the respective setting by the calculated value.
For example, if T= -5 and dT= 2, the new T value is (T+dT= -5 + 2) -3.
9. Once all values are changed, return to the **Print Tests** menu and select **Prt Line Len Cal.**
10. Verify that the adjusted values and the color bands for Cyan, Magenta, and Yellow on all six groups, A through F, are centered between -2 and +2. Repeat if necessary.
Note: The Line Length Calibration must be printed after making any changes to color alignment.
11. Exit diagnostics.

Partial Print Test

Diagnostic procedure for missing or faded planes

1. Turn the printer off.
2. Remove all cartridges and the ITU.
3. Inspect the bellcranks.
4. Enter the Configuration Menu. See **“Entering CONFIG MENU” on page 3-7.**
5. Select **Prt Quality Pgs** and press **Select**.
6. Open the vacuum transport belt (VTB) jam access door and watch the test pages pass from left to right over the VTB.
There is a delay between the first and second page.
7. Once the pages are printed, examine the pages for to confirm the color plane is not printing.
Note: The third page is particularly important since it is the image on the belt when the test printed.
8. Select **Prt Quality Pgs** and press **Select**.
Open the VTB through the access door and, once again, watch the test pages pass over the VTB.
9. When the top half of the second page passes over the VTB, quickly open the front cover. The printing stops.



Approximate
final stopping
place

10. Remove all four toner cartridges and set them face down.

Look at the surface of each toner cartridge and check for a developed image.



Interpreting the results

If the developed images are not visible on one of the PC drums, the following components should be checked:

- Toner cartridge - Switch cartridges to determine if the problem stays with the slot or cartridge.
- Cartridge contact block pins - Verify that pins are spring loaded and properly positioned. See **“Cartridge contact assembly pin locations” on page 5-4**
- Developer HVPS cable - Make sure that there is no damage to the cable running from the system board.
- Developer HVPS board.
- System board.

If the image is well developed on the PC drum, but the same plane is missing or faded on the ITU belt, the following components should be checked:

- Bell cranks - Check the condition of the bell cranks.
- Continuity on the bell crank circuit - Turn the printer off. Using a multimeter, check the continuity between the rear bell crank contact for the failing color and the respective cable on the transfer HVPS board. See **“Transfer high voltage power supply (HVPS)” on page 5-19.**
- Transfer HVPS cable - Make sure that there is no damage to the cable running from the system board to the transfer HVPS board. Verify the connection at both ends.
- Transfer HVPS board.
- Engine board.

Nip relief handle replacement

Removing the old nip relief handle

1. Remove lower left side covers to gain access to the nip relief handle.
2. Remove waste toner container.
3. Reinsert paper tray into printer.
If any fragments fall into the printer they should land in the paper tray and be easy to remove.
4. Remove the broken pieces of old nip relief handle.
 - a. Pull up the upper piece of handle to raise the nip relief link (A) and rotate the upper piece of handle 90° clockwise to free it from the link (A).

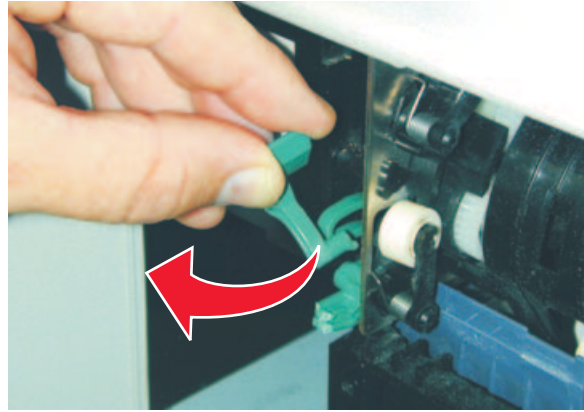
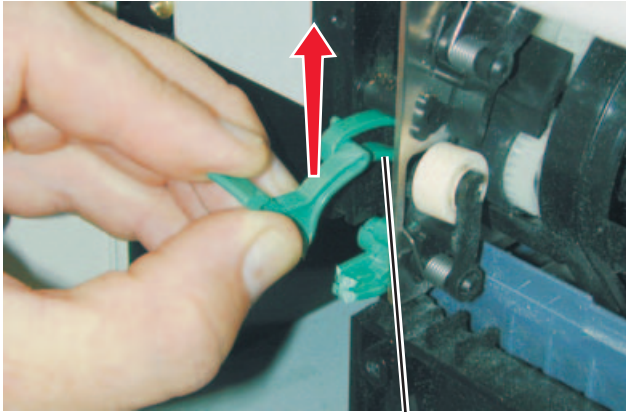

A

- b. Using a side cutter, cut the lower piece of the handle free from the post.
Some scarring of the post is expected, but be careful not to damage the post.

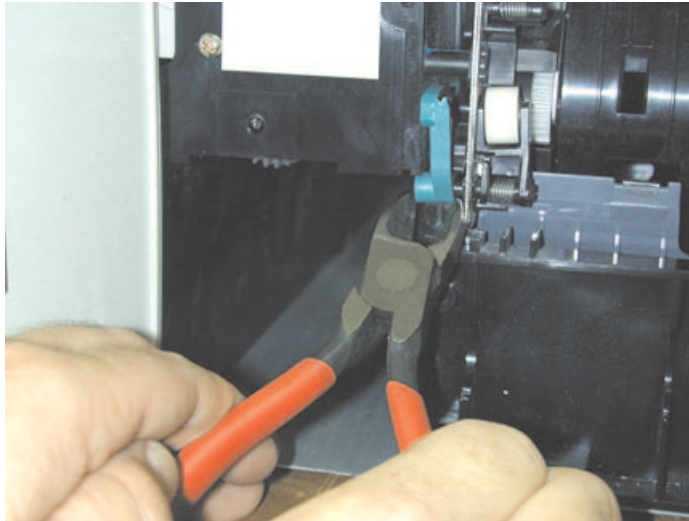

- C.** Remove any remnants of the handle.
Check the paper tray to check for debris. For example, see the fragment (B) in the following picture.

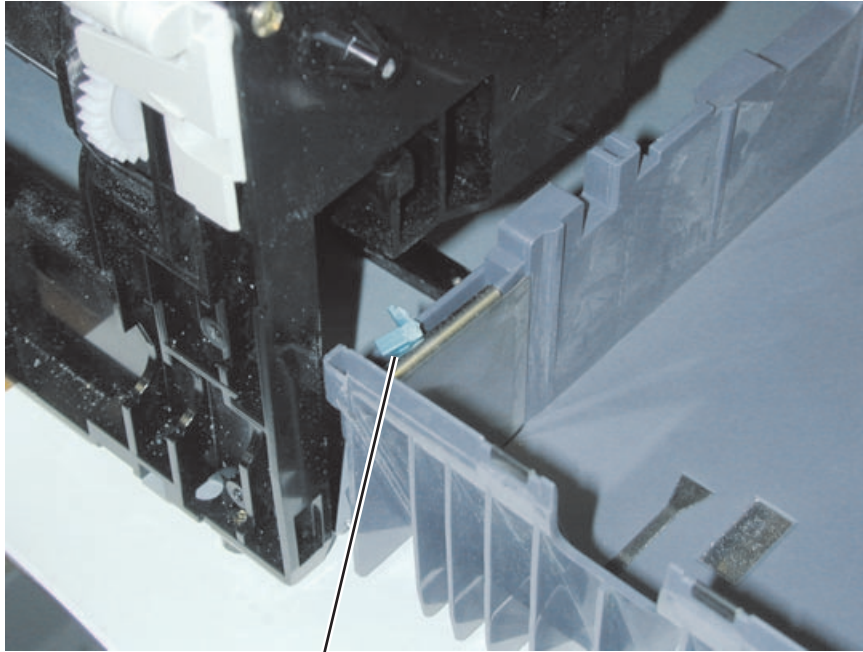

B

Installing the new nip relief handle

1. Rotate the new nip relief handle into place to connect it to the nip relief link (A).

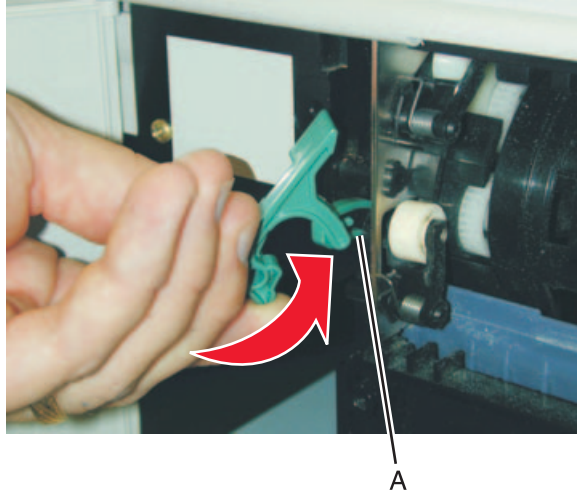

2. Using a screwdriver, gently pry the nip relief lever (B) towards the rear of the machine and insert lower portion of handle so that it is trapped between the lever and the reference edge plate (C).

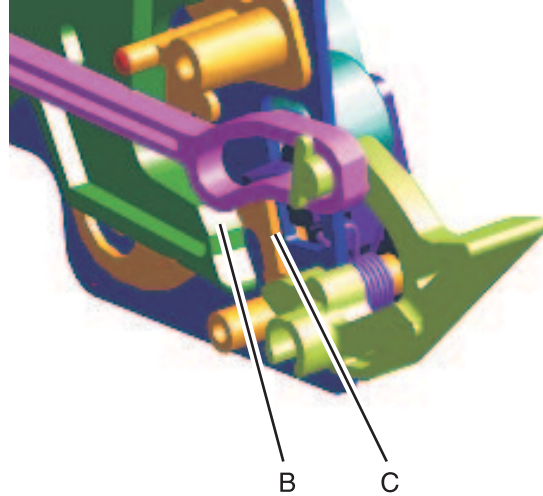
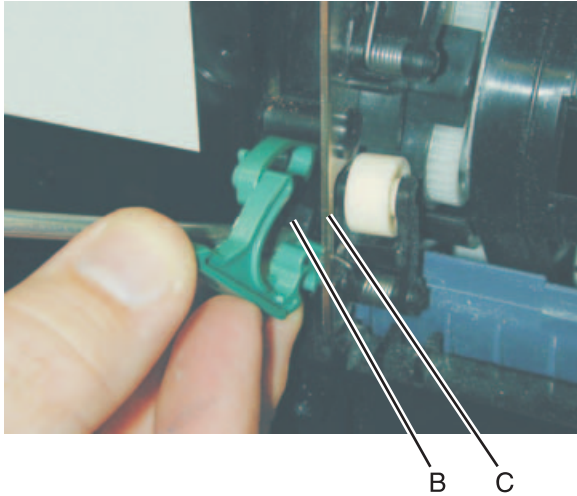

3. Holding the nip relief handle in place, use a flathead screwdriver to gently pry up on the top portion of the lever allowing the handle to press into place onto the post using moderate force.

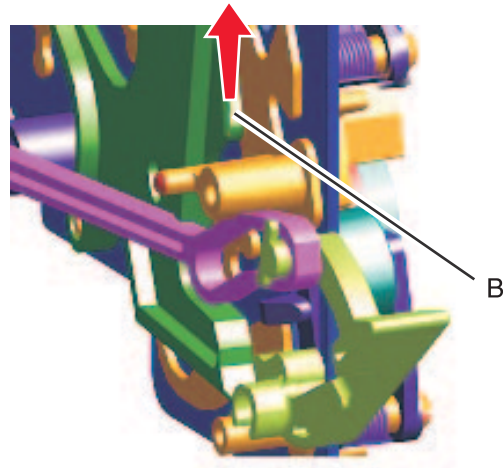
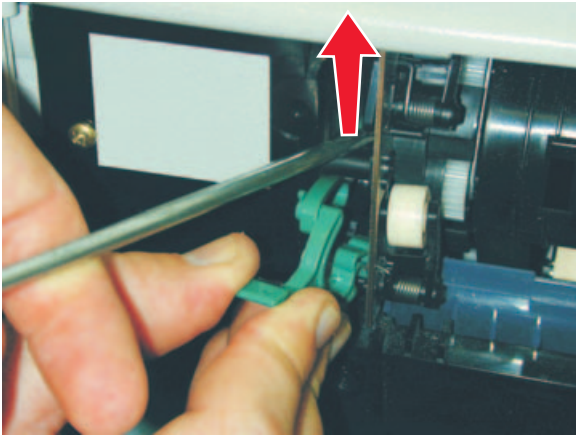

4. Once the handle snaps onto the post, press the upper portion of the handle to the right and rotate the handle into its home position.
This seats the nip relief lever into the correct position.

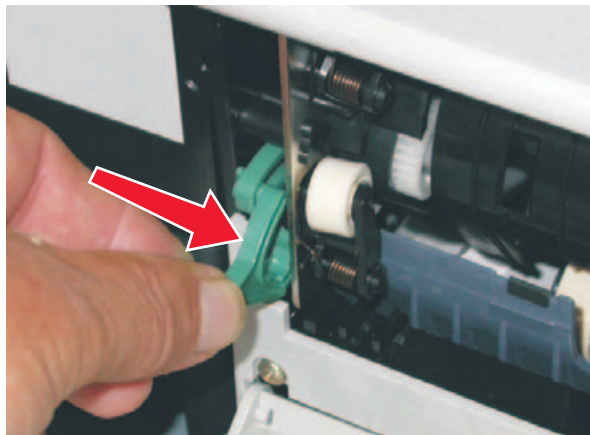

5. Check for proper operation.
6. Install the waste toner container.
7. Replace the covers.

Finisher alignment

This tip provides detailed instructions for aligning the finisher to the printer.

The sides of the finisher must be parallel with the printer and at the same height, or you may have paper feeding problems.

There are four locations where adjustments can be made to correctly align the finisher with the printer. There are two adjustment casters on the left (the side closest to the printer) and two on the right, underneath the platform cover.

Note: The short finisher left casters adjust with caster bolts, while the tall finisher left casters adjust with wingnuts.

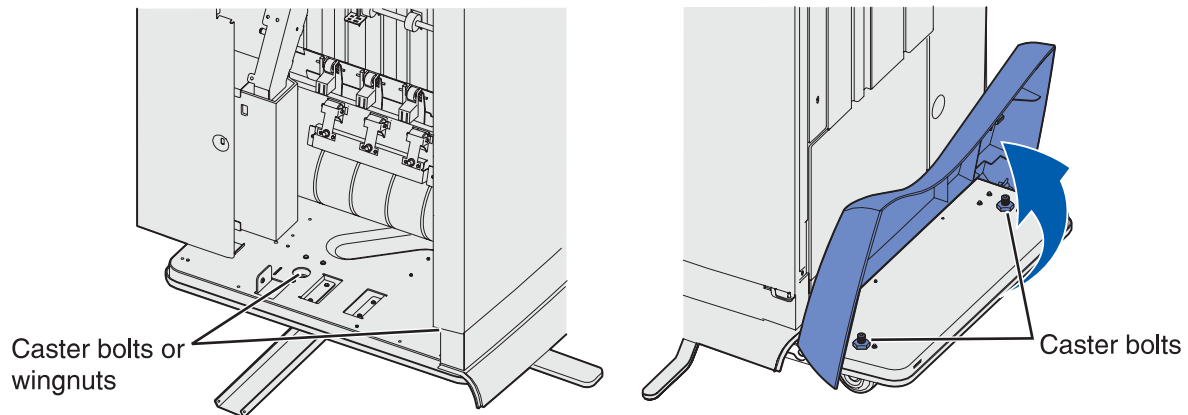

How the casters are adjusted depends on whether you have the short or tall finisher.

- **Short finisher**
 - Printer
 - Optional duplex unit
 - Three additional 500-sheet drawers
 - Printer stand
 - Finisher

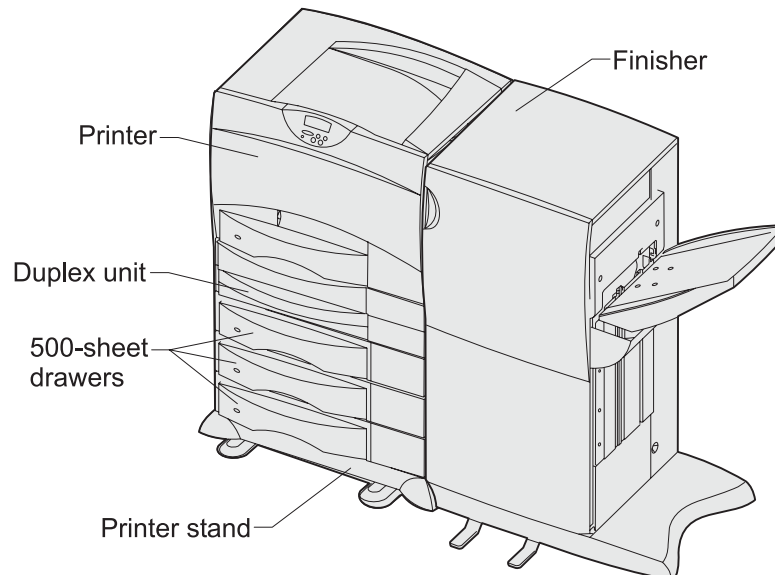

- **Tall finisher**
 - Printer
 - Optional duplex unit
 - One additional 500-sheet drawer
 - Optional 2000-sheet drawer
 - Finisher

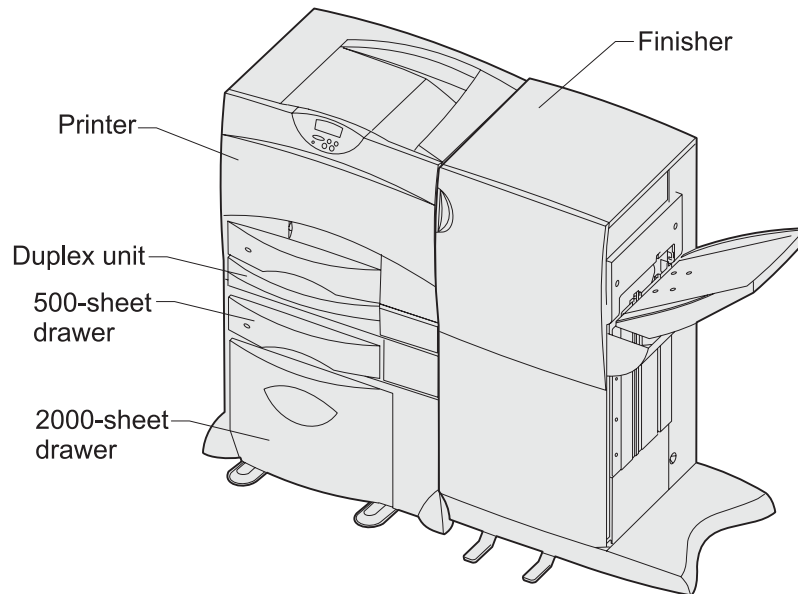

Step 1: Secure the printer

Completely stabilize the printer before the finisher alignment process is started. How this is done depends on whether you have a short or tall finisher.

Short finisher

1. Attach caster brakes (A) to the two back legs of the printer caster base.
2. Screw the caster brakes onto the legs of the caster base.
3. Adjust the leveling feet (B) on the caster brakes so they securely touch the floor.

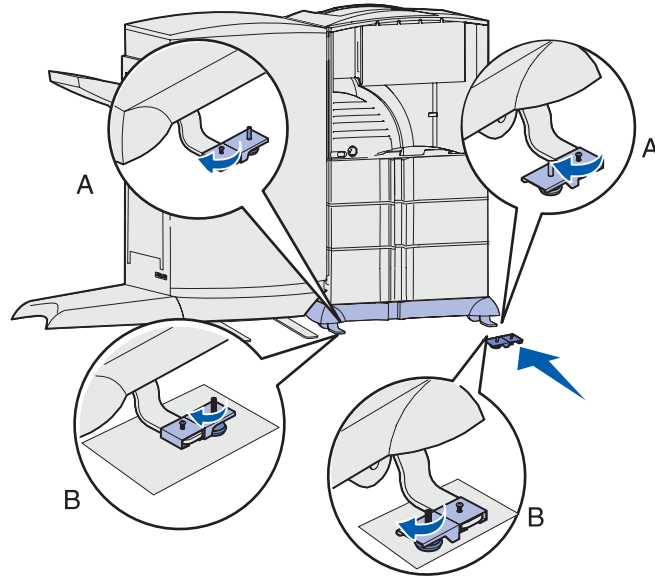

Tall finisher

Adjust the four leveling feet (C) on the bottom of the 2000-sheet drawer so all four securely touch the floor.

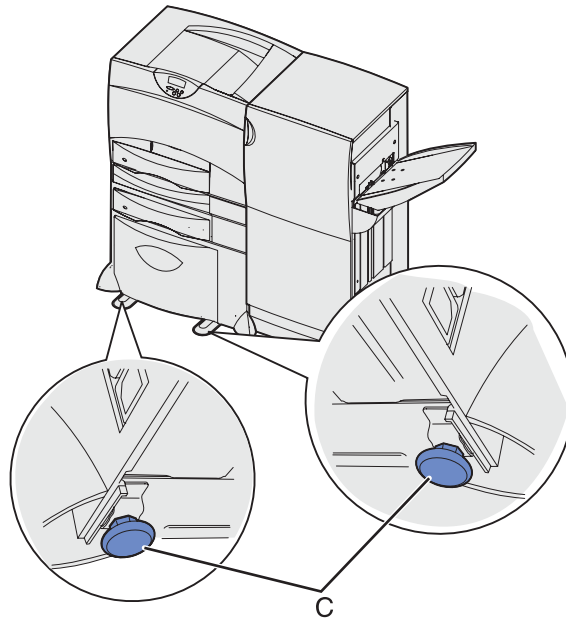

Step 2: Align the pin

Adjust the two casters on the left side (closest to the printer) to raise or lower the finisher as needed, so the pin (D) on the printer properly aligns with the hole in the finisher (the pin should freely slide into the hole).

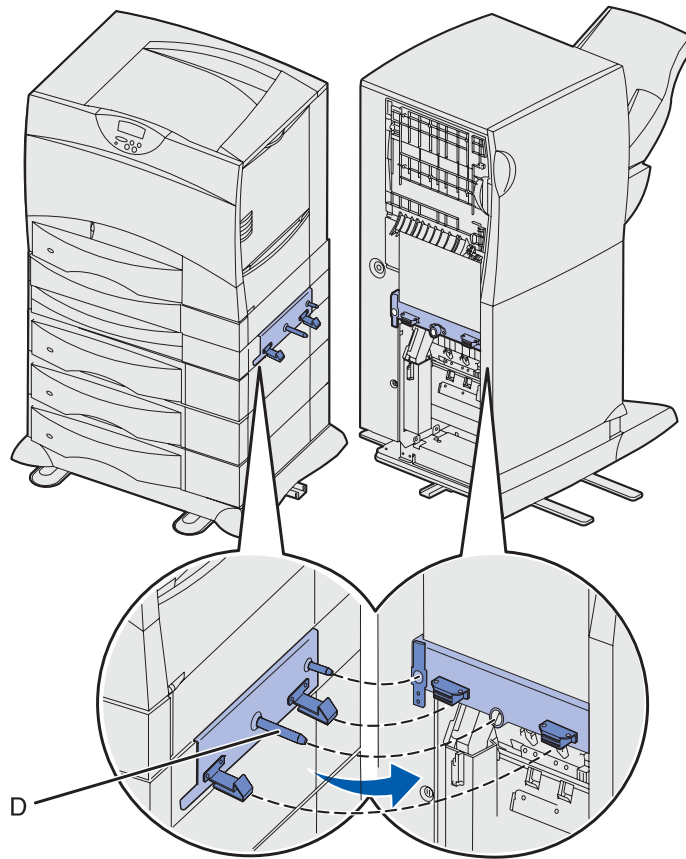

Short finisher

1. Insert the Allen wrench (E) into either caster bolt (F).
2. Rotate the wrench in the appropriate direction to adjust the height of the finisher (clockwise raises the finisher).
3. Repeat with the other caster bolt.

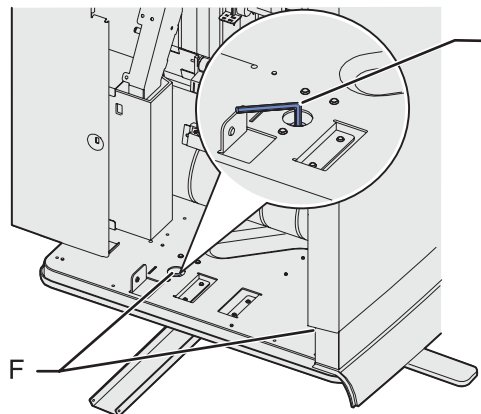

Tall finisher

Loosen or tighten the wingnuts (G) to adjust the height of the finisher (clockwise raises the finisher).

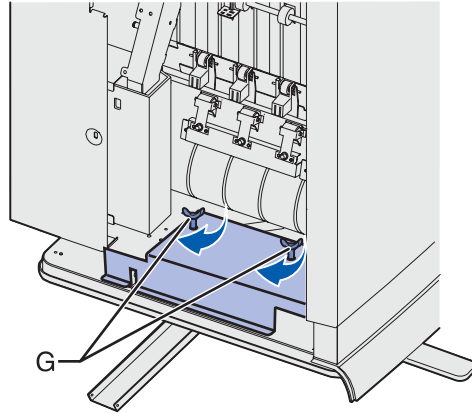

Step 3: Align the bumper pads

Adjust the two casters on the right side (under the platform cover) to raise or lower the finisher as needed so the two bumper pads on the finisher lightly touch the printer.

This ensures that the gap (H) between the printer and finisher is the same from top to bottom.

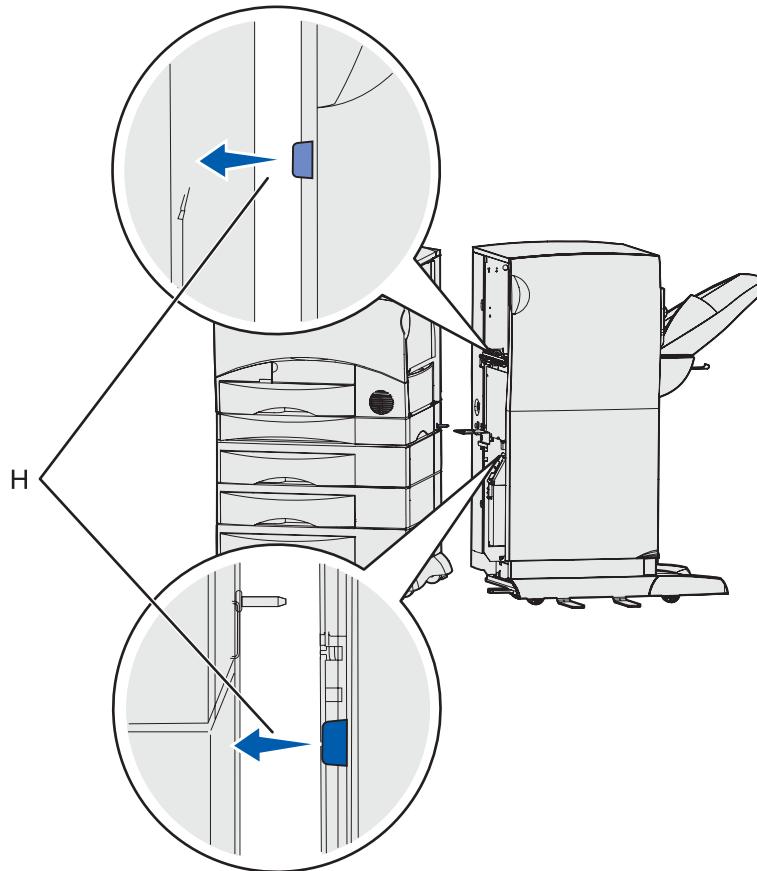

Short and tall finisher

1. Lift the platform cover.
2. Insert the Allen wrench (D) into either caster bolt (J).
3. Rotate the wrench in the appropriate direction to adjust the height of the finisher (clockwise raises the finisher).
4. Repeat with the other caster bolt.

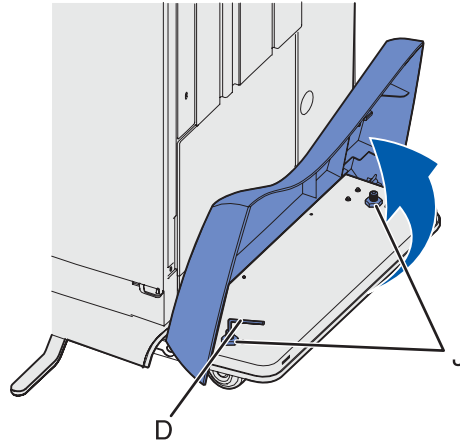

Step 4: Adjust the tilt

If necessary, adjust the tilt of the finisher so that the front is flush with the front of the printer. This can usually be done by adjusting the two front casters (those closest to the finisher door).

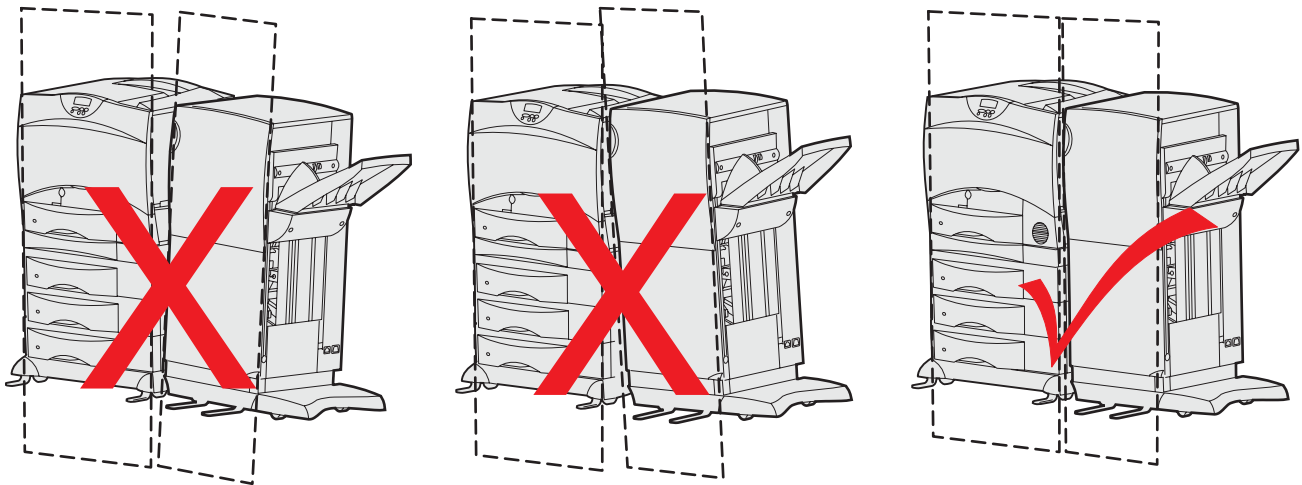

Note: When adjusting the tilt, be sure that the adjustments made in steps 1 and 2 are maintained. Additional adjustments may be necessary in those locations.

If the finisher wobbles after making adjustments in steps 1, 2, and 3, make sure each caster touches the floor.

Step 5: Connect the finisher and printer

Push the finisher against the printer, making sure the gap in the front is the same as the gap in the back.

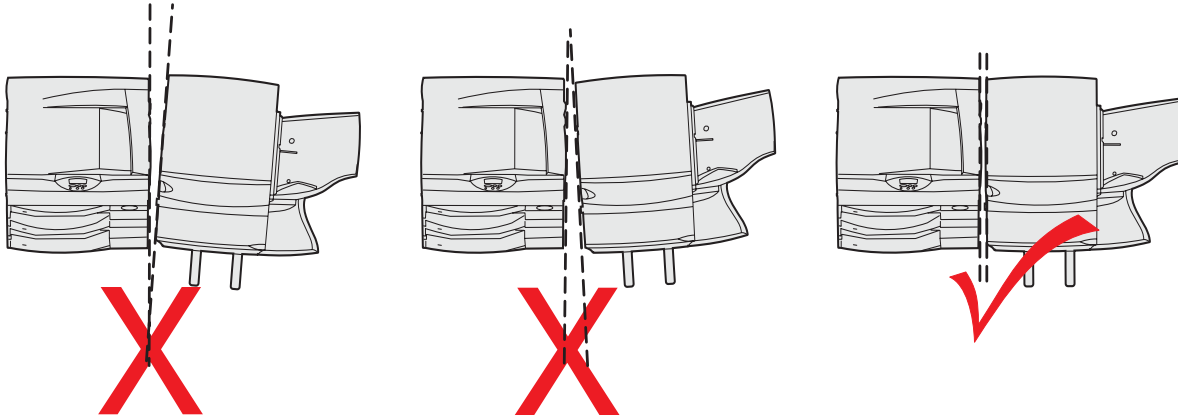

When adjoining the finisher and the printer, make sure that the finisher cable is out of the way of the paper path. If the cable folds itself between the finisher and the printer, disconnect the cable, twist it one time, and then reconnect it. This may help the cable bend the other direction.

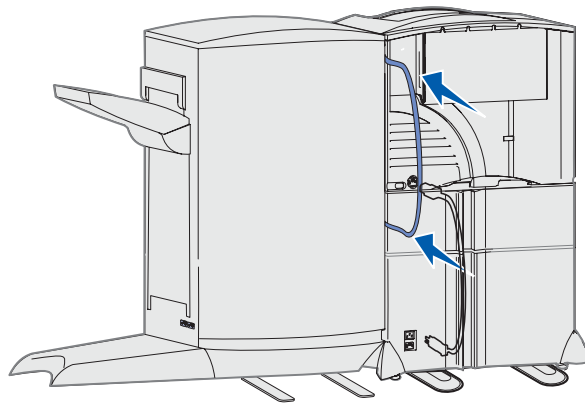

Finisher alignment quick check

Use this table to make sure all alignments have been made.

Make sure:	To make adjustments, see:
1. The printer is secured to the floor.	"Step 1: Secure the printer" on appendix page A-24
2. The finisher's height is correct. The pin should align with the hole in the finisher, and the finisher should easily dock to the printer without interference or binding with the pin.	"Step 2: Align the pin" on appendix page A-25
3. The finisher is vertically aligned to the printer. The finisher's two bumper pads should lightly touch the printer.	"Step 3: Align the bumper pads" on appendix page A-26
4. The finisher's tilt is correct. The printer and finisher's front covers should be flush together at top and bottom. If you run your hand across them from side to side they should feel as if they are one part.	"Step 4: Adjust the tilt" on appendix page A-27
5. The finisher is squarely docked to the printer. The printer and finisher's top covers should have the same distance between them at the front and rear when docked.	"Step 5: Connect the finisher and printer" on appendix page A-28

Duplex option deflector button replacement

During a duplex job, the duplex option fails to actuate the deflector in the fuser and the paper is diverted away from the duplex. The duplex option does not receive the sheet and prompts a 230 Paper Jam message. Replace the rubber deflector button with the compression spring deflector button.

1. The FRU kit contains a spring and button that should be assembled as shown.



2. Remove the deflector button by pulling up.

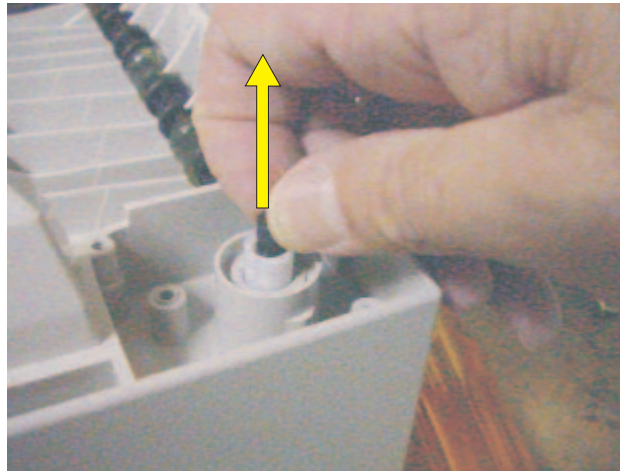

3. Place the new button into the cam.

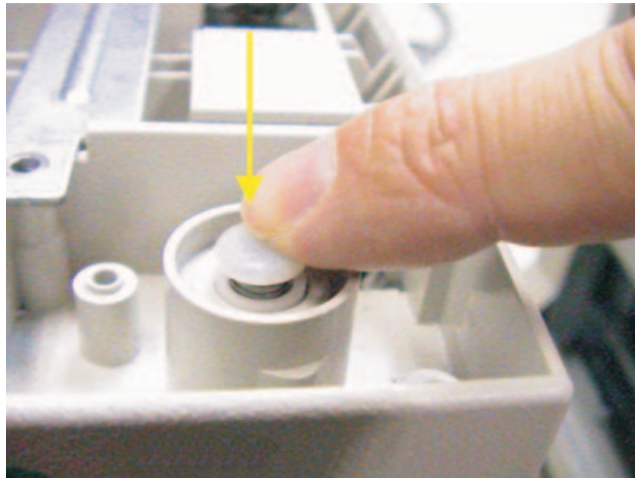

4. Verify the new button moves freely by pressing the button firmly down and watching for it to snap back.
Note: Leave the button in the up position.

Appendix B—Print quality samples

The following pages represent some of the pages available in various menus. While they are as close as possible to what you will see, variations in printing may result from individual user printer settings, media, and printer alignment.

Print Menus—Page one of two

Lexmark C750

SUPPLIES MENU

Cyan Toner = 100% 
 Serial Number = 032140951A
 Capacity = 15 K
 Type = Prebate
 Yellow Toner = 100% 
 Serial Number = 032000292A
 Capacity = 15 K
 Type = Prebate
 Magenta Toner = 100% 
 Serial Number = 032270305A
 Capacity = 15 K
 Type = Prebate
 Black Toner = 100% 
 Serial Number = 032981313A
 Capacity = 15 K
 Type = Prebate

COLOR MENU

Print Mode = Color
 Color Correction = Auto
 Print Resolution = 2400 10
 Toner Darkness = 4

MANUAL COLOR

RGB Image = sRGB Display
 RGB Text = sRGB Vivid
 RGB Graphics = sRGB Vivid
 CMYK Image = US CMYK
 CMYK Text = US CMYK
 CMYK Graphics = US CMYK

PAPER MENU

Paper Source = Tray 1

PAPER SIZE

Tray 1 Size = Letter
 MP Feeder Size = Executive
 Manual Pap Size = Letter
 Manual Env Size = 10 Envelope

PAPER TYPE

Tray 1 Type = Plain Paper
 MP Feeder Type = Labels
 Manual Pap Type = Plain Paper
 Manual Env Type = Envelope

CUSTOM TYPES

Custom Type 1 = Paper
 Custom Type 2 = Paper
 Custom Type 3 = Paper
 Custom Type 4 = Paper
 Custom Type 5 = Transparency
 Custom Type 6 = Paper

UNIVERSAL SETUP

Units of Measure = Inches
 Portrait Width = 8.50
 Portrait Height = 14.17
 Feed Direction = Short Edge
 Substitute Size = All Listed
 Configure MP = Cassette

PAPER TEXTURE

Plain Texture = Normal
 Glossy Texture = Normal
 Card Stock Text = Normal
 Trnsprncy Text = Normal
 Labels Texture = Normal
 Bond Texture = Rough
 Envelope Texture = Normal
 Ltrhead Texture = Normal
 Preprint Texture = Normal
 Colored Texture = Normal
 Custom 1 Texture = Normal
 Custom 2 Texture = Normal
 Custom 3 Texture = Normal
 Custom 4 Texture = Normal
 Custom 5 Texture = Normal
 Custom 6 Texture = Normal

PAPER WEIGHT

Plain Weight = Normal
 Glossy Weight = Normal
 CardStock Weight = Normal
 Trnsprncy Weight = Normal
 Labels Weight = Heavy
 Bond Weight = Normal
 Envelope Weight = Normal
 Ltrhead Weight = Normal
 Preprint Weight = Normal
 Colored Weight = Normal
 Custom 1 Weight = Normal
 Custom 2 Weight = Normal
 Custom 3 Weight = Normal
 Custom 4 Weight = Normal
 Custom 5 Weight = Normal
 Custom 6 Weight = Normal

FINISHING MENU

Copies = 1
 Blank Pages = Do Not Print
 Collation = Off
 Separator Sheets = None
 Separator Source = Tray 1
 Multipage Print = Off
 Multipage Order = Horizontal
 Multipage View = Auto
 Multipage Border = None

UTILITIES MENU

Print Menus
 Print Net Setup
 Print Fonts
 Print Demo
 Color Samples
 Factory Defaults
 Color Adjust
 Nex Trace

SETUP MENU

Printer Language = PS Emulation
 Power Saver = 15
 Resource Save = Off
 Print Timeout = 90
 Wait Timeout = 40
 Auto Continue = Disabled
 Jam Recovery = Auto
 Page Protect = Off
 Print Area = Normal
 Display Language = English
 Alarm Control = Single
 Toner Alarm = Single
 Printer Usage = Max Yield

PCL EMUL MENU

Font Source = Resident
 Font Name = RB Courier
 Pitch = 10,00
 Symbol Set = 10U PC-8
 Orientation = Portrait
 Lines per Page = 60
 A4 Width = 198 mm

TRAY RENUMBER

Assign MP Feeder = Off
 Assign Tray 1 = Off
 Assign Man Paper = Off
 Assign Man Env = Off

VIEW FACTORY DEF

MPF Default = 8
 T1 Default = 1
 T2 Default = 4
 T3 Default = 5
 T4 Default = 20
 T5 Default = 21
 Env Default = 6
 MPap Default = 2
 MEnv Default = 3
 Auto CR after LF = Off
 Auto LF after CR = Off

POSTSCRIPT MENU

Print PS Error = Off
 Image Smoothing = Off

NETWORK MENU

STANDARD NETWORK

PCL SmartSwitch = On
 PS SmartSwitch = On
 NPA Mode = Auto
 Network Buffer = Auto
 MAC Binary PS = Auto

STD NET SETUP

USB MENU

STANDARD USB

PCL SmartSwitch = On
 PS SmartSwitch = On
 NPA Mode = Auto
 USB Buffer = Auto
 MAC Binary PS = Auto

Other Settings

Tray 1 Auto Size = Auto
 PCL Type 1 Fonts = On
 Feed Timeout = 60
 Job Timeout = Disabled
 Stored Job Limit = 5

Print Menus—Page two of two

Lexmark C750

Printer Information

Page Count	3530B
Installed Memory	128MB
Processor Type	RM7000 w/256k L2
Processor Speed	350MHz
Serial Number	140000X
CalStat	1F41F
CalSet	5.50 3.59 3.88
	11.06 12.00
TD1	E 35245.C 35245.C
	35245.C 35245.C
Engine	10.05-R00
Boot	01.00-R00
Engine Card	20A
Loader	853.007A-0
Kernel	K853.005-0
Base	853.007A-0
Network	853.007A-3
Ethernet 10/100	
Panel	7.02
Font	8.09

Installed Features

128MB Memory

Print tests

Print Quality Pages—Title page (total of five)

Lexmark C750 Print Quality Test

Printer Information

Page Count 35316
 Installed Memory 128MB
 Processor Type RM7000 w/256k L2
 Processor Speed 350MHz
 Serial Number 140000X
 CalStat 001F
 CalSet 5.50 3.59 3.88
 11.06 12.00
 TD1 0 35314.S 35314.S
 35314.S 35314.S
 Engine 10.05-R00
 Boot 01.00-R00
 Engine Card 20A
 Loader 853.007A-0
 Kernel K853.005-0
 Base 853.007A-0
 Network 853.007A-3
 Panel 7.02
 Font 8.09

Manufacture Date 0
 Total Refills 0
 Total Cycle Count 0

MARGIN SETTINGS

Top Margin = 0
 Bottom Margin = -6
 Left Margin = 0
 Right Margin = 7
 Cyan Top Margin = 0
 Cyan Left Margin = -3
 Cyan Right Margin = 7
 Cyan Theta Margin = -4
 Cyan Fine Top Margin = 0
 Yellow Top Margin = -7
 Yellow Left Margin = -1
 Yellow Right Margin = -73
 Yellow Theta Margin = -2
 Yellow Fine Top Margin = 0
 Magenta Top Margin = 0
 Magenta Left Margin = -10
 Magenta Right Margin = -70
 Magenta Theta Margin = -4
 Magenta Fine Top Margin = 0

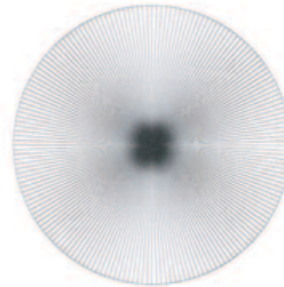

Cartridge Information

Cyan Toner 0% 100%
 Serial Number = 032140951A
 Capacity = 15 K
 Type = Prebate

Yellow Toner 0% 100%
 Serial Number = 032000292A
 Capacity = 15 K
 Type = Prebate

Magenta Toner 0% 100%
 Serial Number = 032270305A
 Capacity = 15 K
 Type = Prebate

Black Toner 0% 100%
 Serial Number = 032981313A
 Capacity = 15 K
 Type = Prebate

EP SETTINGS

Fuser Temp = Normal
 DC Charge Adjust = Normal
 Black = Normal
 CMY = Normal
 Dev Bias Adj = Normal
 Black = Normal
 Magenta = Normal
 Cyan = Normal
 Yellow = Normal

Transfer Adjust = Normal
 Black = Normal
 Magenta = Normal
 Cyan = Normal
 Yellow = Normal

COLOR MENU

Print Mode = Color
 Color Correction = Auto
 Print Resolution = 2400 IQ
 Toner Darkness = 4

ERROR LOG

1-000 2-000
 3-000 4-000
 5-000 6-000
 7-000 8-000
 9-000 10-000
 11-000 12-000

Paper Source = Tray 1
 Formatted Size = Letter

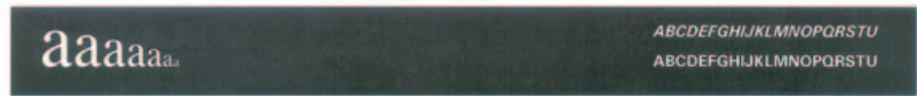

12 - 0123456789::<=>?@ABCDEFGHIJKLMNPNQRSTUUVWXYZ[\]_`abcdefghijklmnopqrstuvwxyz{|}~cÇüé
 10 - 0123456789::<=>?@ABCDEFGHIJKLMNPNQRSTUUVWXYZ[\]_`abcdefghijklmnopqrstuvwxyz{|}~cÇüéäääçéèèìíîïËë.Éèòò
 8 - 0123456789::<=>?@ABCDEFGHIJKLMNPNQRSTUUVWXYZ[\]_`abcdefghijklmnopqrstuvwxyz{|}~cÇüéäääçéèèìíîïËë.Éèòòóóôôõõöö÷÷øøùù
 6 - 0123456789::<=>?@ABCDEFGHIJKLMNPNQRSTUUVWXYZ[\]_`abcdefghijklmnopqrstuvwxyz{|}~cÇüéäääçéèèìíîïËë.Éèòòóóôôõõöö÷÷øøùù

Print Quality Pages—Page 1 (total of five)



Print Quality Pages—Page 2 (total of five)

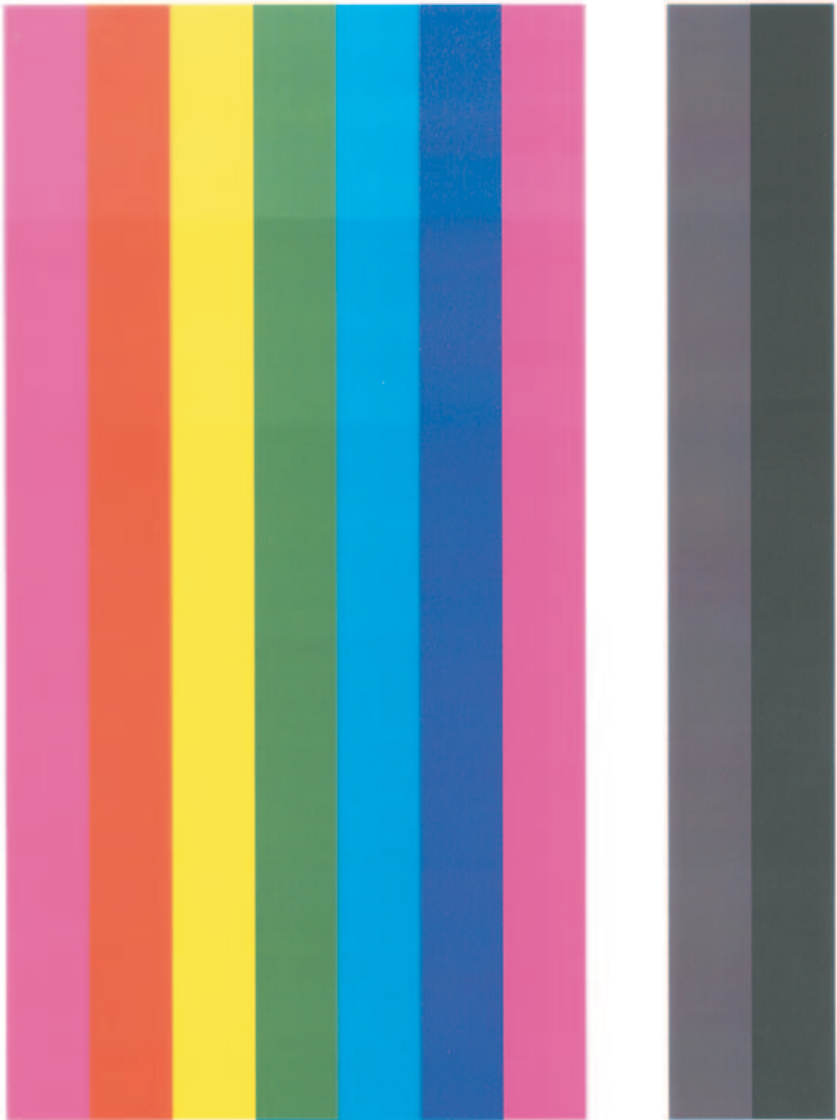

Leiman_C750_600x600.qxd File: FunctionalTest.ppt page 2

Print Quality Pages—Page 3 (total of five)



40% coverage
LaserJet C750 600x600 dpi 1st FunctionalPage page 3

Print Quality Pages—Page 4 (total of five)

13	14	15	16	17	18	19	20	21	22	23	24	25	26	27	28	29	30	31	32	33	34	35	36	37	38	39	40	41	42	43	44	45	46	47	48	49	50	51	52	53	54	55	56	57	58	59	60	61	62	63	64	65	66	67	68	69	70	71	72	73	74	75	76	77	78	79	80	81	82	83	84	85	86	87	88	89	90	91	92	93	94	95	96
----	----	----	----	----	----	----	----	----	----	----	----	----	----	----	----	----	----	----	----	----	----	----	----	----	----	----	----	----	----	----	----	----	----	----	----	----	----	----	----	----	----	----	----	----	----	----	----	----	----	----	----	----	----	----	----	----	----	----	----	----	----	----	----	----	----	----	----	----	----	----	----	----	----	----	----	----	----	----	----	----	----	----	----

Leeman CTSD 600x600 dpi File: FunctionalTest.ps page 4

Registration

Quick Test

Lexmark C750
Quick Test

Printer Information

Page Count	35314
Installed Memory	128MB
Processor Type	RM7000 w/256k L2
Processor Speed	350MHz
Serial Number	140000X
CalStat	001F
CalSet	5.50 3.59 3.88
	11.06 12.00
T01	0 35314.S 35314.S
	35314.S 35314.S
Engine	10.05-R00
Boot	01.00-R00
Engine Card	20A
Loader	853.007A-0
Kernel	K853.005-0
Base	853.007A-0
Network	853.007A-3
Panel	7.02
Font	8.09

MARGIN SETTINGS

Top Margin	= 0
Bottom Margin	= -6
Left Margin	= 0
Right Margin	= 7
Cyan Top Margin	= 0
Cyan Left Margin	= -3
Cyan Right Margin	= 7
Cyan Theta Margin	= -4
Cyan Fine Top Margin	= 0
Yellow Top Margin	= -7
Yellow Left Margin	= -1
Yellow Right Margin	= -73
Yellow Theta Margin	= -2
Yellow Fine Top Margin	= 0
Magenta Top Margin	= 0
Magenta Left Margin	= -10
Magenta Right Margin	= -70
Magenta Theta Margin	= -4
Magenta Fine Top Margin	= 0
Paper Source	= Tray 1
Formatted Size	= Letter

Alignment test pages

Printhead alignment test pages—magenta (one of three)

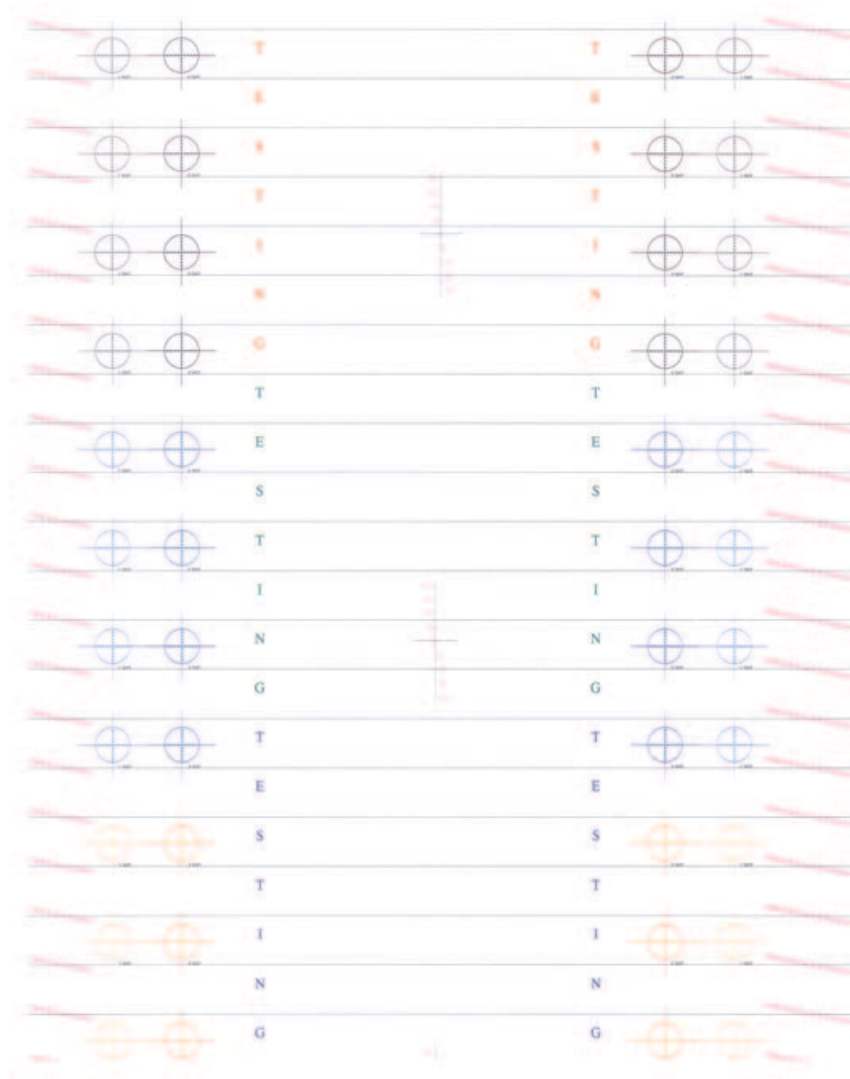

Printhead alignment test page—yellow (two of three)

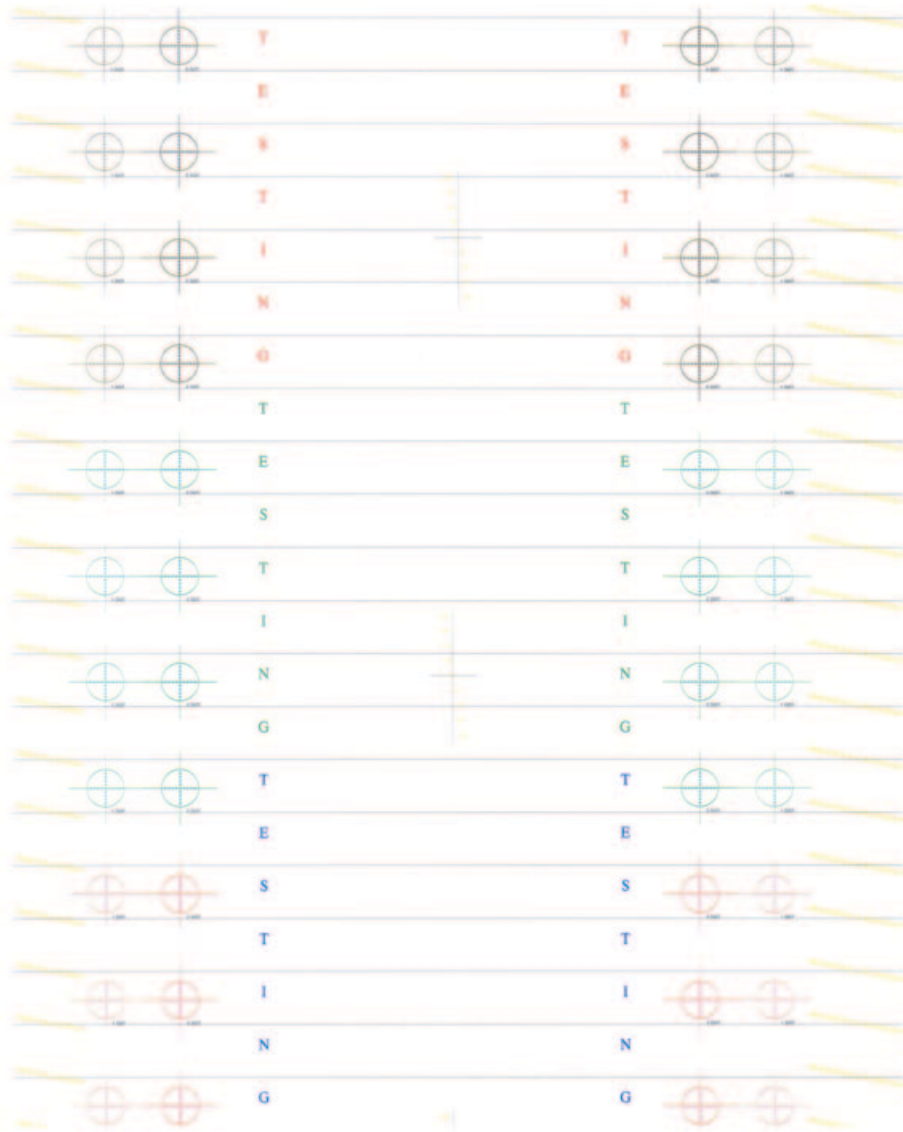

Printhead alignment test page—cyan (three of three)

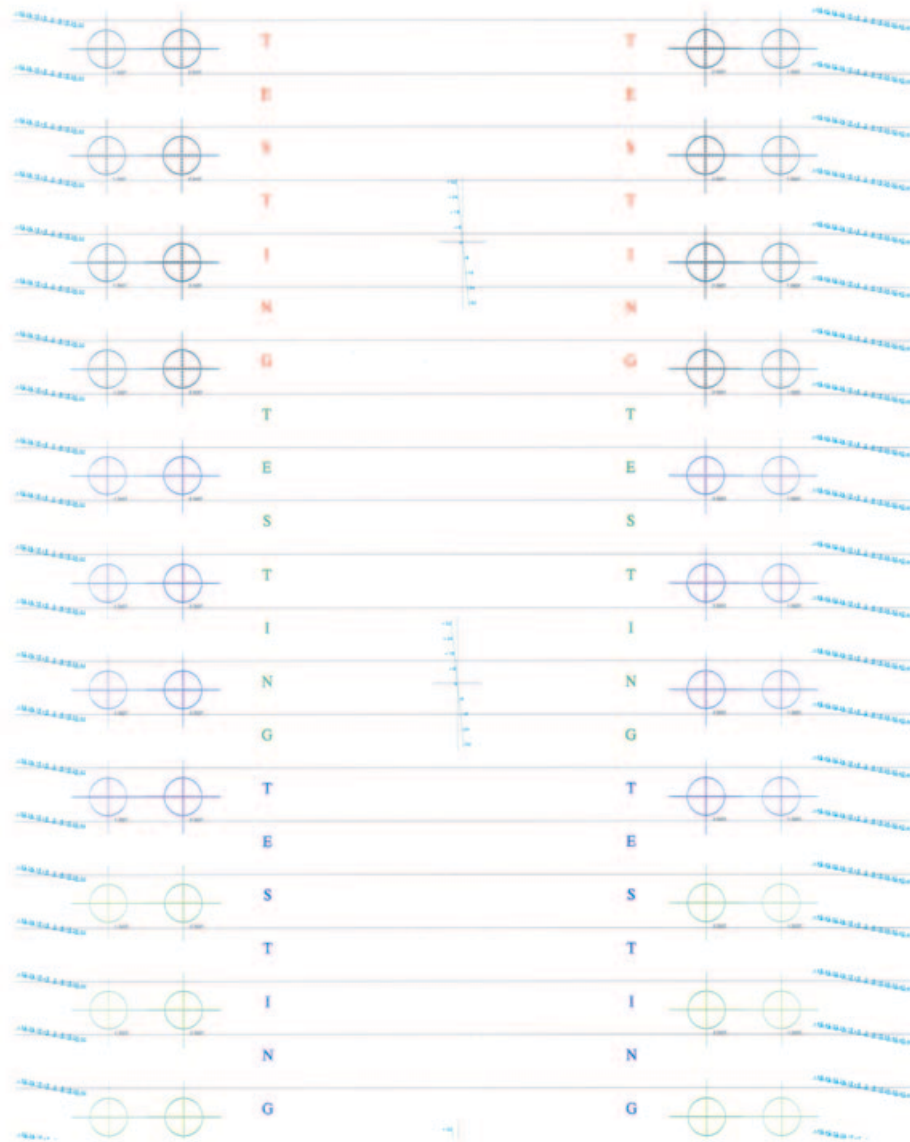

Print Line Len page

Major divisions = 20 pels
Minor divisions = 4 pels

- A -

Adjust the ALIGNMENT settings for Cyan, Yellow, and Magenta by using the following formulas.
The results are a change to the current alignment settings.

$$dT = B \qquad dR = F * 6$$

$$dL = (E - F) * 6 \qquad dZ = (B - C) * 2$$

Use the following equation for more accuracy on the top margin.

$$dT = (A + B + B - C + D) / 3$$

Cyan dT = (___ + ___ + ___ - ___ + ___) / 3
Yellow dT = (___ + ___ + ___ - ___ + ___) / 3
Magenta dT = (___ + ___ + ___ - ___ + ___) / 3

- B -

- C -

- D -

- E -

- F -

Lenmark C750 600x600 dpi file: aligp21.ps

Index

Numerics

- 1565 Emul Error Load **2-41**
- 1xx service errors
 - error table **2-9–2-16**
 - service checks **2-42–2-67**
- 2000-sheet option tray
 - board connectors **5-26**
 - parts catalog **7-64**
 - service check **2-128**
 - standalone test mode **3-34**
 - symptom tables **2-4**
 - system board LED error codes **2-128**
- 2xx paper jams
 - description **2-25–2-27**
 - service checks **2-67–2-88**
 - user attendance message table **2-28–2-30**
- 30-99 user attendance messages **2-34–2-41**
- 500-sheet drawer option
 - parts catalog **7-56**
 - service check **2-108**
 - symptoms **2-4**
- 500-sheet integrated tray
 - parts catalog **7-22**
 - service check **2-149**
- 500-sheet tray option
 - parts catalog **7-58**
 - service check **2-108**
- 5-bin mailbox
 - parts catalog **7-52, 7-54**
 - relocation packaging **7-77**
 - service check **2-104**
 - symptoms **2-5**
- 9xx service errors **2-6–2-9**
 - error code table **2-6–2-9**
 - service checks **2-88–2-104**

A

- acronyms **1-13**
- ALIGNMENT **3-15**
- alignment
 - electronic color alignment **4-58, 8-12**
 - finisher alignment **8-22**
 - print line length calibration **4-61, 8-14**
 - printhead mechanical alignment **4-51, 8-5**
 - test page samples **9-9**
- appendix **8-1**
- attendance messages **2-28**
- Auto Color Adjust **3-12**
- autocompensator assembly
 - parts catalog **7-24**
 - removal **4-17**
 - service check **2-114**
- automated motor detection **3-16**

B

- Base Sensor Test **3-29**
- Belt Tracking **3-17**
- black only retract (BOR) motor
 - location **5-2**
 - removal **4-23**
 - service checks **2-117**
- Black&White Lock **3-7**
- button test **3-19**

C

- cabling interconnections **7-42, 7-44, 7-46, 7-47**
- CACHE Test **3-20**
- CALIBRATE TRAYS **3-9**
- cartridge contact assembly
 - locations **5-4**
 - parts catalog **7-31**
 - removals **4-23**
- cartridge drive assembly
 - lubrication **6-3**
 - parts catalog **7-32**
 - removal, cyan, magenta, black **4-26**
- cartridge mounting, parts catalog **7-6**
- close door switch, removal **2-118**
- Color Trapping **3-8**
- configuration menu
 - Auto Color Adjust **3-12**
 - Black&White Lock **3-7**
 - CALIBRATE TRAYS **3-9**
 - Color Trapping **3-8**
 - Demo Mode **3-10**
 - Download Emuls **3-10**
 - Energy Conserve **3-11**
 - enter **3-7**
 - entering **3-7**
 - Exit Config Menu **3-12**
 - Factory Defaults **3-11**
 - Fuser Cnt Value **3-7**
 - ITU Alignment **3-11**
 - Panel Menus **3-10**
 - PPDS Emulation **3-10**
 - Prt Quality Pgs **3-8**
 - Reset Fuser Cnt **3-8**
 - SENSED PAPER **3-9**
 - SENSED TRANS **3-9**
 - SIZE SENSING **3-8**
 - TYPE SENSING **3-9**
- connectors
 - developer HVPS board **5-20**
 - engine board **5-7**
 - high-capacity output feeder (HCOF) **5-28, 5-29**
 - high-capacity output finisher (HCOF) **5-28**
 - HVPS **5-19**

LVPS **5-22, 5-24**
 RIP board **5-1, 5-14**

covers

parts catalog **7-2, 7-4**
 removals **4-5**

D

Demo Mode **3-10**

developer HVPS board

connectors **5-20**
 locations **5-1**
 removal **4-28**

diagnostic aids

partial print test **3-5**
 print quality defect locator transparency **3-3**
 printhead diagnostic card **3-1**

diagnostics mode

ALIGNMENT **3-15**

Base Sensor Test **3-29**
 Drift Sensor Check **3-16**

DUPLEX TESTS

Quick Test (duplex) **3-23**
 Top Margin Offset (duplex) **3-23**

entering **3-13**

Exit Diagnostics **3-13**

exiting **3-13**

HARDWARE TESTS

Button Test **3-19**
 CACHE Test **3-20**
 DRAM Test **3-20**
 LCD Test **3-19**
 Parallel Wrap Test **3-21**
 ROM Test **3-21**
 Serial Wrap Test **3-22**

MISC TESTS

Belt Tracking **3-17**
 Motor Detect **3-16**

Output Bin Tests

Diverter Test **3-25**
 Feed Test **3-25**
 Feed to All Bins **3-25**
 Sensor Test **3-26**

PRINT TESTS

input sources **3-18**

Printer Setup

Defaults **3-30**
 Reset Calibration **3-31**

Prt Line Len Pg **3-19**

Prt Quality Pgs **3-19**

REGISTRATION **3-14**

TOP FINE MAR ADJ **3-16**

disk test/clean **3-29**

Diverter Test **3-25**

Download Emuls **3-10**

DRAM Test **3-20**

Drift Sensor Check **3-16**

ducts

fuser bottom duct **4-32**
 fuser top duct **4-34**

duplex option

deflector button replacement **8-29**
 error codes **2-8, 2-9**
 parts catalog **7-60, 7-62**
 relocation packaging **7-77**
 service check **2-120**
 sub error codes **2-17**
 tests **3-23**

duplex sensor test **3-23**

duplex tests **3-23**

Duplex Top Margin Offset **3-23**

E

electronics, parts catalog **7-34, 7-36, 7-38, 7-39, 7-40**

Energy Conserve **3-11**

engine board

cabling **7-42, 7-44**
 connectors **5-7**
 diagram **5-7**
 locations **5-1**
 removal **4-29**

error codes

1565 service error **2-41**
 1xx service errors **2-9**
 2xx paper jams **2-25, 2-28**
 3x-8x attendance errors **2-34**
 9xx service errors **2-6**

error log

clearing **3-33**
 viewing **3-33**

ESD-sensitive parts **4-1**

Exit Config Menu **3-12**

Exit Diagnostics **3-13**

F

Factory Defaults **3-11**

features **1-2**

Feed Test **3-25**

Feed to All Bins **3-25**

finisher

alignment **8-22**
 error codes **2-122**
 LVPS board connectors **5-28**
 parts catalog **7-68, 7-70, 7-72**
 service check **2-122**
 sub LVPS relay board connectors **5-28**
 symptoms **2-5**
 system board connectors **5-29**
 system board diagram **5-32**
 tests **3-27**

finisher feed test **3-27**

finisher sensor test **3-27**

flash test **3-30**

friction buckler **4-30**

fuser assembly

parts catalog **7-8**
 removal **4-31**
 service check **2-127**

Fuser Cnt Value **3-7**

fuser drive assembly
 lubricating replacement motors **6-2**
 lubrication **6-2**
 parts catalog **7-12**
 removal **4-33**

fuser web oiler
 parts catalog **7-10**
 replacements **1-4**
 upgrade kit **1-4**

fuser web oiler motor assembly
 installation **4-36**
 removal **4-35**

H

hardware tests **3-19**

HCIT standalone test mode **3-34**

high-capacity input tray (HCIT) **7-64, 7-66**

board connectors **5-26**
 service check **2-128**
 standalone test mode **3-34**
 symptoms **2-4**
 system board LED error codes **2-128**

high-capacity output finisher (HCOF)

alignment **8-22**
 error codes **2-122**
 LVPS board connectors **5-28**
 parts catalog **7-68, 7-70, 7-72**
 sub LVPS relay board connectors **5-28**
 symptoms **2-5**
 system board connectors **5-29**
 system board diagram **5-32**
 tests **3-27**

hole punch test **3-28**

HVPS

connectors **5-19**
 developer board **4-28**
 locations **5-1**
 transfer HVPS board **4-80**

I

input print tests **3-18**

input tray feed test **3-24**

input tray sensor test (500-sheet trays) **3-24**

input tray tests **3-24**

installation

narrow media sensor assembly **4-75**
 redrive assembly **4-68**
 S2/NMS/transparency sensor assembly **4-75**
 web oiler motor assembly **4-36**

installations

transparency sensor assembly **4-75**

ITU Alignment **3-11**

ITU assembly

alignment **3-11**
 parts catalog **7-25**
 removals **4-37**
 service check **2-42**

ITU drive assembly

lubrication **6-3**

removals **4-37**

ITU loading, parts catalog **7-28**

L

LCD Test **3-19**

LCD test **3-19**

locations

developer HVPS board **5-1**

engine board **5-1**

LVPS **5-1**

RIP board **5-1**

thermistor card **5-1**

transfer HVPS board **5-1**

lubrication specifications **6-1, 6-2**

LVPS

engine and RIP board connectors **5-22**

fuser connectors **5-24**

locations **5-1**

removal **4-38**

M

maintenance kits **6-4**

media specifications **1-7**

memory tests

cache **3-20**

DRAM **3-20**

ROM **3-21**

messages

error codes **2-6**

user attendance messages **2-28**

models **1-1**

Motor Detect **3-16**

multipurpose feeder (MPF)

parts catalog **7-20**

removal **4-40**

N

nip relief handle **4-42, 8-18**

nip shock **3-4**

O

operator panel

parts **7-2**

removal **4-46**

service check **2-132**

options

description **1-2**

parts catalog **7-76**

output expander

parts catalog **7-48, 7-50**

relocation packaging **7-77**

service check **2-134**

symptoms **2-5**

P

packaging **7-77**
 Panel Menus **3-10**
 paper feed output (redrive) **7-16**
 paper size sensing
 parts catalog **7-18**
 service check, tray 1 **2-150**
 Parallel Wrap Test **3-21**
 partial print test **3-5**
 parts catalog **7-16, 7-64, 7-66**
 500-sheet integrated tray **7-22**
 500-sheet tray option **7-56, 7-58**
 5-bin mailbox **7-52, 7-54**
 autocompensator assembly **7-24**
 cartridge contact assembly **7-31**
 cartridge drive assembly **7-32**
 cartridge mounting **7-6**
 covers **7-2, 7-4**
 duplex option **7-60, 7-62**
 electronics **7-34, 7-36, 7-38, 7-39, 7-40**
 electronics—cabling interconnections **7-46, 7-47**
 electronics—cabling interconnections 1 **7-42, 7-44**
 finisher **7-68, 7-70, 7-72**
 fuser assembly **7-8**
 fuser assembly (web oiler) **7-10**
 fuser drive assembly **7-12**
 high-capacity input tray (HCIT) **7-64, 7-66**
 ITU assembly **7-25**
 ITU loading **7-28**
 miscellaneous **7-77**
 multipurpose feeder (MPF) **7-20**
 options **7-76**
 output expander **7-48, 7-50**
 paper feed input **7-17**
 paper feed transport **7-19**
 paper size sensing **7-18**
 printheads **7-15**
 transfer **7-14**
 vacuum transport belt assembly **7-13**
 parts packets **7-77**
 pick tires, removal **4-48**
 POR sequence **2-2**
 power cords **7-35**
 power-on reset (POR) **2-2**
 PPDS Emulation **3-10**
 preventative maintenance **6-1**
 print quality
 black and white only **2-142**
 blank page (no image) **2-139**
 entire page is one color **2-140**
 horizontal line **2-137**
 horizontal lines or streaks **2-137**
 light lines or streaks **2-138**
 light print **2-142**
 light print - all colors **2-142**
 low image density **2-143**
 missing colors **2-141**
 negative ghost image **2-144**
 one color has light print **2-143**

 poor color alignment **2-144**
 residual image **2-145**
 service check **2-136**
 smudged or distorted images **2-146**
 toner is on the back of the printed page **2-146**
 toner smears or rubs off the page **2-145**
 transparency print quality is poor **2-147**
 uneven printing **2-145**
 vertical lines or streaks **2-138**
 white streak in color plane **2-138**
 print quality pages
 configuration menu **3-8**
 diagnostic mode **3-19**
 print quality samples **9-1**
 print registration **3-14**
 print test (input source) **3-18**
 printer alignment procedures
 printhead mechanical alignment **4-51, 8-5**
 printhead assembly
 parts catalog **7-15**
 removal **4-50**
 printhead diagnostics **3-1**
 printhead thermistor card
 parts **7-15**
 removal **4-62**
 Prt Line Len Pg **3-19**
 Prt Quality Pgs **3-8, 3-19**
 PSD sensor assembly replacement **4-63**

Q

quick disk test **3-29**

R

rear bellcrank **4-64, 4-66**
 redrive
 parts catalog **7-16**
 redrive door removal **4-14**
 removal **4-68**
REGISTRATION 3-14
 registration motor
 parts catalog **7-19**
 removal **4-69**
 relocation kit **7-77**
 removals
 autocompensator pick assembly **4-17**
 BOR housing assembly **4-23**
 cartridge contact assembly **4-23**
 cartridge drive assembly (cyan, magenta, black) **4-26**
 covers
 front cover assembly **4-10**
 front left handle cover assembly **4-10**
 front lower left cover **4-16**
 front right handle cover assembly **4-9**
 left lower cover **4-13**
 lower jam access door assembly **4-14**
 lower right door assembly **4-12**
 paper path access door cover **4-15**
 rear cover **4-8**
 rear fan cover **4-8**

- redrive door **4-14**
- top cover assembly **4-5**
- developer HVPS board **4-28**
- engine board **4-29**
- engine board shield **4-30**
- friction buckler **4-30**
- fuser assembly **4-31**
- fuser bottom duct **4-32**
- fuser drive assembly **4-33**
- fuser fan **4-34**
- fuser top duct **4-34**
- fuser web oiler motor assembly **4-35**
- ITU assembly **4-37**
- ITU drive assembly **4-37**
- ITU drive motor **4-38**
- LVPS **4-38**
- multipurpose feeder (MPF) **4-40**
- narrow media sensor assembly **4-72**
- nip relief handle **4-42**
- operator panel **4-46**
- outer EMC shield **4-47**
- paper size sensing assembly **4-48**
- pick tires **4-48**
- printhead thermistor card **4-62**
- printheads **4-50**
- PSD sensor assembly **4-63**
- rear bellcrank (black) **4-66**
- rear bellcrank (cyan, magenta, yellow) **4-64**
- redrive assembly **4-68**
- registration motor **4-69**
- RIP board **4-70**
- RIP board shield assembly **4-71**
- RIP fan **4-71**
- S2/NMS/transparency sensor assembly **4-72**
- second transfer roll **4-79**
- transfer HVPS board **4-80**
- transfer plate assembly **4-81**
- transparency sensor assembly **4-72**
- vacuum transport belt (VTB) **4-82**
- VTB fan **4-84**
- waste container door **4-84**
- waste container latch **4-85**
- web oiler fuser kit installation **4-85**
- replacement motors, lubrication **6-2**
- Reset Calibration **3-31**
- Reset Fuser Cnt **3-8**
- RIP board
 - cabling **7-42, 7-44**
 - connectors **5-14**
 - installation notes **4-70**
 - locations **5-1**
 - removal **4-70**
- ROM Test **3-21**

S

- S2/NMS/transparency sensor assembly **4-72**
- safety information **v-xvii**
- safety inspection guide **6-1**
- scheduled maintenance **6-4**
- screw identification table **4-2**
- second transfer roll
 - parts **7-14**
 - removal **4-79**
 - service check **2-148**
- SENSED PAPER **3-9**
- SENSED TRANS **3-9**
- Sensor Test **3-26**
- sensors
 - locations **5-3**
 - paper size sensing assembly **4-48**
 - S2/NMS/transparency assembly removal **4-72**
- Serial Wrap Tests **3-22**
- service checks
 - 1xx service checks **2-42-2-67**
 - 2xx service checks **2-67-2-88**
 - 500-sheet drawer option **2-108**
 - 5-bin mailbox option **2-104**
 - 9xx service checks **2-88-2-104**
 - AC and DC power **2-112**
 - autocompensator **2-114**
 - black only retract (BOR) **2-117**
 - close door/HVPS/printhead interlock switch **2-118**
 - duplex option **2-120**
 - finisher **2-122**
 - fuser **2-127**
 - high-capacity input tray (HCIT) **2-128**
 - operator panel LCD/status LED/buttons **2-132**
 - output expander **2-134**
 - print quality **2-136**
 - second transfer roll **2-148**
 - tray 1 **2-149**
 - tray 1 paper size sensing **2-150**
- service tips
 - duplex option deflector button replacement **8-29**
 - finisher alignment **8-22**
 - nip relief handle replacement **8-18**
 - partial print test **8-16**
 - printhead alignment **8-4**
 - printhead diagnostics **8-1**
- SIZE SENSING **3-8**
- specifications
 - acoustics **1-5**
 - calibration **1-2**
 - clearances **1-4**
 - dimensions **1-3**
 - electrical **1-4**
 - environment **1-5**
 - lubrication **6-1**
 - media **1-7**
 - memory **1-7**
 - performance **1-2, 1-6**
 - power **1-3**
 - print quality **1-2**

- reliability **1-2**
- resolution **1-3**
- staple test **3-27**
- start here **2-1**
- sub error code tables **2-17**
- symptom tables **2-3**
- symptoms
 - 500-sheet drawer option **2-4**
 - 5-bin mailbox option **2-5**
 - base printer **2-3**
 - finisher option **2-5**
 - HCIT 2000-sheet option **2-4**
 - output expander option **2-5**

T

- tests
 - button test **3-19**
 - disk test/clean **3-29**
 - duplex sensor test **3-23**
 - finisher
 - finisher feed test **3-27**
 - finisher sensor test **3-27**
 - hole punch test **3-28**
 - staple test **3-27**
 - flash test **3-30**
 - HCIT standalone test mode **3-34**
 - input tray feed test **3-24**
 - input tray sensor test (500-sheet trays) **3-24**
 - LCD test **3-19**
 - quick disk test **3-29**
- thermistor card
 - locations **5-1**
 - parts catalog **7-15**
- tips **8-1**
- toner metering cycle (TMC)
 - locations **5-4**
 - service check **2-93, 2-95, 2-97, 2-99**
- tools **1-1**
- TOP FINE MAR ADJ **3-16**
- transfer HVPS board
 - locations **5-1**
 - parts **7-38**
 - removal **4-80**
- transfer plate assembly
 - parts **7-14**
 - removal **4-81**
- transparency, defect locator **3-3**
- TYPE SENSING **3-9**

U

- user attendance messages **2-28**

V

- vacuum transport belt (VTB)
 - parts catalog **7-13**
 - removal **4-82**
- vacuum transport belt (VTB) fan
 - parts catalog **7-41**
 - removal **4-84**

W

- waste container door **4-84**
- waste container latch **4-85**
- web oiler drive motor
 - locations **5-2**
- web oiler fuser
 - parts catalog **7-10**
 - removal **4-85**
 - replacements **1-4**
 - upgrade kits **1-4**

Part number index

P/N	Description	Page
11A9095	Power cord set, U.S., Canada, Brazil, Colombia, Costa Rica, Dominican Republic, Ecuador, El Salvador, Guatemala, Honduras, Nicaragua, Panama, Venezuela, Puerto Rico, Virgin Islands, Mexico, Asia Pacific (English), Japan, Taiwan, Saudi Arabia	7-35
12G1695	MarkNet N2001e Ethernet 10/100BaseTX	7-76
12G1696	MarkNet N2002e Ethernet 10BaseT/2	7-76
12G5303	Second transfer roll	7-14
12G6301	Fuser assembly 115V 500W	7-9
12G6302	Fuser assembly 220V 500W	7-9
12G6309	Parts packet, screw	7-3, 7-5, 7-37, 7-38, 7-39, 7-57, 7-63
12G6309	Parts packet, screw type 323	7-77
12G6309	Parts packet, screw, board mounting	7-55
12G6309	Parts packet, screws	7-12
12G6309	Registration motor assembly screw	7-19
12G6309	Screw, parts packet	7-27, 7-29
12G6310	Cable, video printhead - yellow	7-45
12G6311	Cable, video printhead - cyan	7-45
12G6312	Cable, video printhead - magenta	7-45
12G6312	Printhead assembly - cyan, includes HSYNC and mirror motor cables	7-45
12G6313	Cable, video printhead - black	7-45
12G6314	Cable, thermistor - yellow and cyan	7-45
12G6315	Cable, thermistor - magenta and black	7-45
12G6316	Cable, HVPS control - developer	7-43
12G6317	Cable, HVPS control - transfer	7-43
12G6318	Cable, engine/RIP communications	7-43
12G6319	Cable, options - stacker	7-3, 7-43
12G6320	Cable, options - bottom	7-43
12G6321	Cable, operator panel	7-45
12G6322	Printhead assembly	7-15
12G6322	Printhead assembly - black, includes HSYNC and mirror motor cables	7-45
12G6322	Printhead assembly - magenta, includes HSYNC and mirror motor cables	7-45
12G6322	Printhead assembly - yellow, includes HSYNC and mirror motor cables	7-45
12G6323	Engine board	7-39
12G6326	Riser card assembly w/o support brackets	7-37
12G6327	Transfer HVPS board	7-38
12G6328	Developer HVPS board	7-38
12G6329	Cable, LVPS to engine board and fuser, attached to LVPS	7-43
12G6329	Cable, LVPS to engine/power, attached to LVPS	7-43
12G6329	Cable, LVPS to RIP board power, attached to LVPS	7-43
12G6329	LVPS, 115V	7-35
12G6330	LVPS, 220V	7-35
12G6331	RIP board ground shield	7-37
12G6332	RIP board cover shield	7-37
12G6333	RIP board shield assembly	7-37
12G6334	INA riser support bracket	7-37
12G6335	Standoff, INA RIP spacer	7-37
12G6336	Engine board shield	7-39
12G6337	Fuser lamp, 115V 500W hot roll	7-9
12G6338	Fuser lamp, 115V 400W backup roll	7-9
12G6339	Blank, TLI/SN label	7-5

5060-00x

12G6340 Fuser top duct	7-5
12G6341 Fuser lamp, 220V 500W hot roll	7-9
12G6342 Fuser lamp, 220V 400W backup roll	7-9
12G6343 RIP fan duct	7-41
12G6344 Operator panel assembly, low volt	7-3
12G6345 Operator panel assembly, high volt	7-3
12G6346 Buckler housing	7-21
12G6347 Front hold down bellcrank	7-3
12G6349 Cable, fuser and yellow cartridge motor	7-43
12G6350 Cable, cyan and magenta cartridge drive motors	7-43
12G6350 Cable, cyan and magenta cartridge motor	7-43
12G6353 Cartridge support roller	7-29
12G6354 Rib housing	7-21
12G6355 Redrive door	7-16
12G6356 Door assembly, lower right	7-16
12G6356 Lower right door assembly	7-3
12G6357 Front cover assembly	7-3
12G6358 Fuser bottom duct	7-5
12G6360 Fuser wall duct	7-5
12G6361 Cable, attached to RIP fan	7-43
12G6361 RIP fan	7-41
12G6376 Rear hold down spring	7-31
12G6376 Spring, rear hold down	7-3
12G6377 Rear hold down bellcrank	7-31
12G6380 Machine pad	7-3, 7-57
12G6382 Cable, attached to main fan	7-43
12G6382 Fuser fan	7-41
12G6383 Fuser latch slide	7-5
12G6384 Fuser latch slide spring	7-5
12G6385 #58 Gear	7-27
12G6386 Duplex actuator arm	7-5
12G6387 Cable, ground	7-43, 7-45
12G6387 Ground strap	7-39
12G6388 Front lower left cover	7-3
12G6389 Top front support bracket	7-3
12G6390 Rear cover	7-5
12G6391 Paper path access door	7-3
12G6392 Left upper pivot cover	7-5
12G6393 Right front cover	7-3
12G6394 Front lower right cover	7-3
12G6395 Cover, left lower	7-5
12G6396 Right rear cover	7-3
12G6397 Front access door support	7-3
12G6398 Left lower pivot cover	7-5
12G6399 Front upper pivot cover	7-3
12G6400 Waste container door	7-5
12G6401 Rear fan cover	7-5
12G6402 Operator panel bezel with logos	7-3
12G6403 Spring, paper path access door	7-3
12G6404 Left front light shield cover	7-3
12G6405 Front right light shield cover	7-3
12G6408 Left upper cover assembly	7-5
12G6409 Cover, redrive cap	7-53
12G6409 Redrive cap cover assembly	7-3
12G6410 Top cover assembly	7-3
12G6411 Front right handle cover assembly	7-3
12G6412 Front left handle cover assembly	7-3

12G6413 ITU light shield assembly	7-25
12G6416 500-Sheet tray assembly	7-23, 7-59
12G6417 Side restraint	7-23, 7-59
12G6418 Back restraint	7-23, 7-59
12G6419 Back restraint latch	7-23, 7-59
12G6420 Tray wear clip	7-23, 7-59
12G6421 Wear strip	7-23, 7-59
12G6425 Tray bias bellcrank assembly	7-23, 7-59
12G6426 Tray bias spring	7-23, 7-59
12G6427 Pick assembly 500-tray	7-24
12G6439 Black terminal contact assembly	7-29
12G6440 Magenta terminal contact assembly	7-29
12G6441 Cyan terminal contact assembly	7-29
12G6442 Terminal, contact spring	7-29
12G6446 BOR housing assembly with motor	7-30
12G6446 Cable, attached to BOR lift motor	7-43
12G6447 Friction buckler	7-21
12G6448 Cable, MPF paper level	7-43
12G6449 MPF cable cover	7-21
12G6450 MPF door assembly	7-21
12G6451 MPF autocompensator pick assembly	7-21
12G6452 MP feeder door cover	7-21
12G6453 Frame bias latch	7-21
12G6454 Frame bias spring	7-21
12G6455 Frame bias latch cover	7-21
12G6456 Sensor mount bracket	7-21
12G6457 MPD support bracket cover	7-21
12G6458 MPF support bracket spring	7-21
12G6459 MPF support bracket	7-21
12G6460 Door hinge restraint	7-21
12G6461 Paper out/low sensor	7-21
12G6461 Sensor, paper out/low	7-24
12G6462 MPF bracket assembly	7-21
12G6463 MPF drive gear	7-21
12G6464 MPF drive gear shaft	7-21
12G6465 MPF drive gear bushing	7-21
12G6466 Paper size sensing link	7-18
12G6467 Paper size sensing spring	7-18
12G6468 Paper size sensing bracket	7-18
12G6469 Waste container latch	7-18
12G6470 Waste container latch spring	7-18
12G6471 Tray interlock bellcrank	7-24, 7-57
12G6472 Tray interlock bracket	7-24
12G6476 Paper level sensing assembly	7-24
12G6479 Cable, attached to VTB fan	7-43
12G6479 VTB fan	7-41
12G6480 Cable, attached to registration motor	7-43
12G6480 Registration motor	7-19
12G6482 Gear, staging reduction #1	7-19
12G6483 Gear, staging idler	7-19
12G6484 Gear, reference plate drive	7-19
12G6485 Lower access jam door assembly	7-5
12G6486 Cable assembly (includes S2/NMS/transparency sensors)	7-43
12G6486 S2/transparency/narrow media sensor assembly	7-17
12G6487 Ground strap	7-37
12G6488 Transfer plate assembly	7-14
12G6489 Vacuum transport belt assembly	7-13

12G6490 VTB fan gap cover	7-41
12G6491 Jam access spring	7-13
12G6492 Redrive assembly	7-16
12G6493 Upper door hinge	7-16
12G6495 Fuser assembly, web oiler 100V 500W	7-11
12G6496 Fuser assembly 100V 500W	7-9
12G6496 Maintenance kit 115V	6-4
12G6497 Maintenance kit 220V	6-4
12G6498 Maintenance kit 100V	6-4
12G6502 100 V web oiler fuser	1-4, 6-4
12G6502 100 V web oiler upgrade kit	1-4
12G6503 Cable, printhead interlock/cover open	7-45
12G6503 Cable, printhead interlock/cover open (3-wire)	7-3, 7-25
12G6504 Cable, HVPS interlock/cover open	7-43
12G6504 Cable, HVPS interlock/cover open (2-wire)	7-3, 7-25
12G6506 Bin full sensor	7-3
12G6506 Cable, bin full sensor, with sensor	7-43
12G6507 250 output flag, includes flag retainer	7-3
12G6509 Card assembly, 64MB SDRAM	7-76
12G6509 SDRAM DIMM 64MB	7-37
12G6510 Cable tie	7-5, 7-57
12G6510 Cable Tie (6 in pack)	7-63
12G6511 Cable mount	7-37
12G6512 Lower front door latch	7-16
12G6513 Lower rear door latch	7-16
12G6514 110 V web oiler fuser	1-4, 6-4
12G6514 115V web oiler upgrade kit	1-4
12G6514 Fuser assembly, web oiler 115V 500W	7-11
12G6515 220 V web oiler fuser	1-4, 6-4
12G6515 220 V web oiler upgrade kit	1-4
12G6515 Fuser assembly, web oiler 220V 500W	7-11
12G6516 Fuser lamp, 100V 500W hot roll	7-9
12G6517 Fuser lamp, 100V 400W backup roll	7-9
12G6529 Screws, fuser fan mounting	7-41
12G6530 Parts packet, screw	7-3, 7-16, 7-33, 7-38
12G6530 Parts packet, screw type 324	7-77
12G6530 Parts packet, screws	7-41
12G6530 Screw, parts packet	7-63
12G6531 Parts packet, screw	7-39
12G6531 Parts packet, screw type 232	7-77
12G6531 Parts packet, Screw, paper size sensing assembly mounting	7-18
12G6532 Parts packet, screw	7-3, 7-7
12G6532 Parts packet, screw type 102	7-77
12G6533 Parts packet, screw	7-15, 7-16, 7-21, 7-23, 7-59, 7-61
12G6533 Parts packet, screw type 312/322/412/423	7-77
12G6533 Parts packet, screws	7-65, 7-67
12G6533 Screw, parts packet	7-29
12G6534 Parts packet, screw	7-15
12G6534 Parts packet, screw type 484	7-77
12G6535 Guide assembly, left side	7-7
12G6536 Guide assembly, right side	7-7
12G6538 Parts packet, 500-sheet tray	7-77
12G6539 Parts packet, screw	7-15
12G6539 Parts packet, screw type 124	7-77
12G6540 Parts packet, screw	7-35, 7-38
12G6540 Parts packet, screw type 121	7-77
12G6541 Standoff, high voltage power supply - developer	7-38

12G6543 Web oiler index drive assembly	7-11
12G6545 Web oiler assembly	7-11
12G6545 Web oiler replacement	1-4
12G6546 Yellow terminal contact assembly	7-29
12G6550 500-Sheet Option tray pick assembly	7-57
12G6552 Base door assembly	7-57
12G6553 Pass thru sensor	7-57
12G6554 Paper guide	7-57
12G6555 500 option deflector	7-57
12G6556 Cover, frame	7-57
12G6557 Bellcrank lift spring	7-24, 7-57
12G6558 Pick arm lift bellcrank	7-24, 7-57
12G6559 Electronics/size sensing assembly with system board	7-57
12G6560 500 base assembly	7-57
12G6561 Spring	7-57
12G6562 Hinge	7-57
12G6563 Wall support plate	7-57
12G6565 Paper level sensing assembly	7-57
12G6566 Paper size sensing assembly	7-57
12G6567 Grounding spring	7-57
12G6568 Reflector label	7-23, 7-59
1339517 Power cord set, Bolivia, Peru	7-35
1339519 Power cord set, Kuwait, Bahrain, Qatar, UAE, Oman, Pakistan, Yemen, Iraq, Libya, Cyprus, UK, Ireland	7-35
1339520 Power cord set	7-35
1339521 Power cord set Israel (HV)	7-35
1339522 Power cord set Switzerland HV (French/German and Italian)	7-35
1339523 Power cord set South Africa (HV), Namibia (HV), Lesotho (HV), Botswana (HV)	7-35
1339524 Power cord set Chile (HV)	7-35
1339525 Power cord set Denmark, (HV)	7-35
1339544 Power cord set Argentina (HV)	7-35
43H5544 Power cord set, PRC	7-35
56P0161 RS-232-C serial/parallel 1284-C adapter	7-76
56P0162 Adapter, parallel 1284 C-B	7-76
56P0167 Anchor, bracket mounting	7-16
56P0168 Drive assembly, 500 option 2	7-57
56P0169 Parts packet, screw	7-49, 7-51
56P0174 Cable assembly, 2nd transfer voltage	7-46
56P0310 Cable, signature button, attached to black HV contact assembly	7-45
56P0310 Cable, signature button, attached to cyan HV contact assembly	7-45
56P0310 Cable, signature button, attached to magenta HV contact assembly	7-45
56P0310 Cable, signature button, attached to yellow HV contact assembly	7-45
56P0310 Cartridge contact assembly, complete	7-31
56P0310 Cartridge contact assembly, complete, cyan/magenta/yellow	7-47
56P0311 Cable ITU autoconnect	7-43
56P0311 Cable, ITU Autocomp out with CB lead	7-47
56P0315 Punch assembly	7-71
56P0316 Staple assembly	7-73
56P0317 Cartridge staple	7-69
56P0317 Staple cartridge	7-73
56P0318 Box chad	7-71
56P0319 Accumulator w/o stapler	7-73
56P0320 Cover front door	7-69
56P0321 Top cover (tall finisher)	7-69
56P0322 Tray paper	7-71
56P0323 Output tray offset motor and gear assembly	7-71
56P0324 Motor assembly elevator tray	7-71

56P0325 Motor assembly paper feed	7-71
56P0326 Flag paper full	7-71
56P0327 Paper feed belt (40S3M888)	7-71
56P0328 Inverter transfer belt (40S3M198)	7-71
56P0329 Inverter D drive belt (40S3M225)	7-71
56P0330 Paper feed-input belt (40S3M279)	7-73
56P0331 Exit foam Roller drive belt (40S3M80)	7-71
56P0332 Accumulator paper feed belt (40S3M900)	7-71
56P0333 Tray elevator belt (60S6M1420)	7-71
56P0334 Tray elevator drive belt (170P2M4)	7-71
56P0335 Exit roller drive belt (40S2M264)	7-71
56P0336 Output tray offset drive belt (40S2M176)	7-71
56P0337 Punch belt (40S2M176)	7-71
56P0338 Low voltage power supply	7-71
56P0340 Cable, communications	7-71, 7-75
56P0341 Power cord	7-71, 7-75
56P0342 Caster	7-71
56P0343 Punch timing sensor (OJ-541-A5)	7-71
56P0344 Inverter timing sensor (OJ511K-A5)	7-73
56P0345 Punch motor homing sensor (GP1A73A)	7-71
56P0346 Chad box full sensor (EE-SPY415)	7-73
56P0346 Exit timing sensor (EE-SPY415)	7-71
56P0347 Inverter jam/tray near full/output tray offset sensor (EE-SX1235A-P2)	7-71
56P0347 Jogger fence homing sensor (EE-SX460-P1-CHN)	7-73
56P0348 Drop timing sensor (OS-535223-602)	7-73
56P0349 Accumulator homing sensor (OS-311D-A5)	7-73
56P0350 Paper surface sensor (EE-SX460-P1-CHN)	7-71
56P0351 Cover open switch	7-73
56P0352 Printer docking switch SS-5FL-3T(10E)	7-71
56P0354 Bracket finisher alignment	7-71
56P0355 Guide vertical paper	7-73
56P0356 Pack magnet, strong and weak and door latch	7-71
56P0357 Actuation assembly	7-71
56P0358 Accumulator slides	7-73
56P0359 Harness cable assembly H2	7-75
56P0360 Harness cable assembly H3	7-75
56P0361 Harness cable assembly H4	7-75
56P0362 Harness cable assembly H5	7-75
56P0363 Harness cable assembly H6	7-75
56P0364 Harness cable assembly S1	7-75
56P0368 Harness cable assembly S5	7-75
56P0369 Harness cable assembly E2	7-75
56P0370 Harness cable assembly E3	7-75
56P0371 Harness cable assembly E5	7-75
56P0372 Harness cable assembly E6	7-75
56P0373 Harness cable assembly E7	7-75
56P0374 Harness cable assembly E8	7-75
56P0375 Harness cable assembly E9	7-75
56P0376 Harness cable assembly E10	7-75
56P0378 Harness cable assembly R1	7-75
56P0379 Harness cable assembly D1	7-75
56P0380 Harness cable assembly D2	7-75
56P0381 Harness cable assembly D3	7-75
56P0382 Harness cable assembly D5	7-73, 7-75
56P0383 Solenoid inverter	7-71
56P0384 Accumulator belt (hook)	7-73
56P0385 Solenoid drop assembly	7-73

56P0386 Fan assembly DC motor	7-71
56P0387 Bar tip unit	7-69
56P0388 Tray limit switch	7-71
56P0400 Cover, front	7-51
56P0401 Rear cover	7-49
56P0402 Cover, rear support	7-49
56P0405 Door assembly, right jam access	7-51
56P0407 Shield, output option card	7-49
56P0408 Output Expander assembly, mechanical linkage	7-49
56P0409 Cover, front control board	7-49
56P0410 Bracket, attach	7-51
56P0411 Door, front	7-53
56P0412 Rear structural cover	7-53
56P0413 Cover, left side	7-53
56P0415 Cover, right	7-53
56P0416 Cover, top bin	7-53
56P0417 Flag, bin full	7-53
56P0418 Bracket, attach front	7-55
56P0420 Bracket asm, bail attach	7-53
56P0421 Spring, static ground	7-55
56P0422 Latch, access door front	7-53
56P0423 Latch, rear access door	7-53
56P0430 Duplex card assembly	7-63
56P0432 Duplex front jam tray assembly	7-61
56P0433 Right jam clearance tray assembly	7-63
56P0434 Right side front tray guide	7-61
56P0435 Duplex shaft mount	7-61
56P0436 Upper rib assembly	7-63
56P0437 Duplex output sensor	7-63
56P0439 Duplex paper guide	7-61
56P0441 Duplex shaft assembly	7-61
56P0442 Duplex exit sensor	7-61
56P0444 F/R backup shaft assembly	7-61
56P0445 40T shaft drive F/R gear	7-61
56P0447 Duplex entry shaft assembly	7-61
56P0449 Support decurl guide	7-61
56P0451 Backup spring assembly	7-63
56P0452 Backup spring assembly	7-63
56P0454 Wall support	7-61
56P0455 Sensor mount plate	7-61
56P0456 Duplex support plate	7-63
56P0457 Duplex support bracket	7-61
56P0458 Chassis ground spring	7-63
56P0459 Back support	7-63
56P0462 Autoconnect cable assembly	7-63
56P0463 DC forward/reverse motor assembly	7-63
56P0464 DC duplex feed motor	7-63
56P0465 Drive alignment shaft assembly	7-63
56P0466 Spur drive gear	7-61
56P0467 26T duplex gear	7-61
56P0468 Pass thru spring	7-61
56P0470 Aligner arm spring	7-61
56P0471 Bellcrank assembly	7-61
56P0472 Pass thru shaft assembly	7-61
56P0473 Brake pad	7-61
56P0474 Decurl BAC assembly	7-61
56P0475 Brake spring	7-61

56P0476 5 mm bushing	7-61
56P0477 Reduction gear shaft	7-63
56P0478 Aligner spring	7-63
56P0479 Front decurl assembly	7-61
56P0480 Back cover	7-61
56P0482 Pulley washer	7-61
56P0483 Deflector actuator assembly	7-61
56P0490 Jumper, AC power cord	7-65
56P0491 Caster, movable	7-67
56P0492 Caster, fixed	7-67
56P0493 F adjuster	7-67
56P0494 System control board	7-65
56P0495 LVPS	7-65
56P0497 AC power outlet	7-65
56P0498 AC power inlet	7-65
56P0500 Front cover	7-67
56P0501 Cover, main CA	7-67
56P0503 Right side cover	7-67
56P0504 Left side cover	7-67
56P0505 Rear cover	7-67
56P0506 Locating pin, options rear left	7-67
56P0507 Locating pin, options front right	7-67
56P0508 Upper left side jam cover	7-67
56P0509 Cable, feed unit special sensors	7-67
56P0510 Cable, feed unit sensors	7-67
56P0511 Paper size sensors cable	7-65
56P0512 Cable, elevator motor	7-67
56P0513 Elevator motor assembly	7-65
56P0514 Options autoconnect cable assembly	7-67
56P0515 Magnetic latch	7-67
56P0516 Sensor, photo interrupter	7-65
56P0517 Options cable mounting plate	7-67
56P0518 Flag, paper size C	7-65
56P0519 Flag, paper size R	7-65
56P0520 Flag, paper size F	7-65
56P0522 Spring, paper size flag	7-65
56P0523 Paper tray arms	7-65
56P0524 Paper tray guide	7-65
56P0525 Feed unit, complete assembly	7-65
56P0526 Sensors, special optical	7-65
56P0527 Bushing	7-65
56P0528 Feed roller	7-65
56P0529 Feed cam	7-65
56P0530 Spring, feed unit	7-65
56P0531 Parts packet, E-clips	7-65
56P0532 Bushing, 060	7-65
56P0533 Spring, feed unit front	7-65
56P0534 Spring, feed unit rear	7-65
56P0535 Clip, plastic 5W	7-65
56P0536 Level sensor flag	7-65
56P0539 Near empty sensor flag	7-65
56P0540 Spring, extension	7-65
56P0541 Tray present lever	7-67
56P0542 Separation/torque roller	7-65
56P0543 Cable clamp	7-67
56P0544 Emitter timing wheel	7-65
56P0547 Elevator lift belt	7-65

56P0548 Elevator lift gear	7-65
56P0549 Elevator lift	7-65
56P0550 Cable, tray media level sensor	7-55
56P0551 Cable, paper media low/out	7-24
56P0551 Cable, paper out/low and transparency media 2 sensors	7-43
56P0552 Cable, autocompensator motor	7-43
56P0552 Cable, pick motor extension	7-24
56P0560 Rear ITU guide	7-29
56P0561 Paper size sensor box assembly	7-65
56P0562 Feed cover	7-65
56P0563 Ring 7, elevator lift gear/elevator lift	7-65
56P0564 Kit, stabilizer with mounting screws	7-67
56P0566 Finisher install kit	7-69
56P0568 ITU drive motor, SKC	7-27
56P0569 Rear cover	7-69
56P0573 Upper right side cover (tall finisher)	7-69
56P0574 Lower tray cover	7-69
56P0575 Front/rear lower cover	7-69
56P0576 Bottom kick cover	7-69
56P0577 Lower right side cover	7-69
56P0578 Tray wall cover	7-71
56P0594 Cam, BOR front	7-29
56P0595 Cam, BOR rear	7-29
56P1120 Card assembly, Bar code	7-76
56P1187 RIP board assembly, non-network, Model 5060-001	7-37
56P1188 RIP board assembly - network, model 5060-002	7-37
56P1198 Thermistor card	7-15
56P1213 Fuser drive assembly	7-12
56P1214 Cartridge drive assembly, cyan/magenta/black	7-33
56P1215 Cartridge drive assembly, yellow	7-33
56P1216 Cable, waste toner full, attached to ITU drive assembly	7-43
56P1216 ITU motor drive assembly with SKC motor	7-27
56P1237 Autocomp shaft assembly	7-24
56P1238 Fuser drive motor	7-12
56P1277 Paper tray guide	7-3
56P1280 Harness cable assembly stapler	7-75
56P1286 Upper right side cover (short finisher)	7-69
56P1287 Scanner plate (short finisher)	7-69
56P1290 Cover wire	7-69
56P1295 ITU assembly	7-25
56P1431 MarkNet X2011e Ethernet 10/100 BaseTX-1 port	7-76
56P1432 MarkNet X2012e Ethernet 10/100 BaseTX/10 Base2 - 1 port	7-76
56P1433 MarkNet X2031e Ethernet 10/100 Base TX - 3 port	7-76
56P1434 MarkNet X2030e Token-Ring - 3 port	7-76
56P1461 Card assembly, ImageQuick	7-76
56P1471 HCOF control board assembly	7-71
56P1495 Parts packet, ITU loading - yellow	7-29
56P1496 Parts packet, ITU loading - cyan	7-29
56P1497 Parts packet, ITU loading - magenta	7-29
56P1498 Parts packet, ITU loading - black	7-29
56P1502 Cable assembly, HVPS control - transfer	7-47
56P1502 Cable, HVPS control - transfer	7-46
56P1504 Active restraint pad	7-23, 7-59
56P1561 Cartridge contact assembly, complete black	7-47
56P1565 Cable assembly, black terminal contact	7-46
56P1566 Cable assembly, magenta terminal contact	7-46
56P1567 Cable assembly, cyan terminal contact	7-46

56P1568 Cable assembly, yellow terminal contact	7-46
56P2031 Cable, web oiler motor	7-43
56P2107 Card assembly IPDS/SCS/Tne	7-76
56P2199 Nip relief handle	7-19
56P2204 Redrive belt 300 T	7-16
56P2216 Shield, door spring	7-3
56P2217 Handle, front access door	7-3
56P2218 Detent, front access door	7-3
56P2219 Housing, front access door	7-3
56P2220 Parts packet, screw	7-3
56P2246 Detent spring	7-3
56P2290 Fuser lift duct	7-5
56P2291 Redrive belt cover duct	7-5
56P2292 Printhead spacer	7-15
56P2294 Accumulator drive belt (B30S2M334)	7-71, 7-73
56P2295 Jogger fence belt (B40S2M460)	7-73
56P2296 Card assembly, printhead diagnostic aid	7-15
56P2484 Belt, transfer	7-63
56P2489 Label, top paper jam, 221/222	7-3
56P9909 Card assembly, PRESCRIBE	7-76
56P9910 Card assembly, 128MB SDRAM	7-76
56P9910 SDRAM DIMM 128MB	7-37
56P9911 Card assembly, 256MB SDRAM	7-76
56P9912 Card assembly, 4MB flash DIMM	7-76
56P9913 Card assembly, 8MB flash DIMM	7-76
56P9914 Card assembly, 16MB flash DIMM	7-76
56P9926 Lexmark Optra Forms software	7-76
56P9927 Lexmark Forms Director software	7-76
56P9928 Lexmark Forms 4MB flash DIMM	7-76
56P9929 Lexmark Forms 8MB flash DIMM	7-76
56P9930 Lexmark Forms 16MB flash DIMM	7-76
56P9932 Lexmark Forms 64MB flash DIMM	7-76
56P9934 MarkNet Token-Ring Print Server	7-76
56P9935 Card assembly, Traditional Chinese font DIMM	7-76
56P9936 Card assembly, Simplified Chinese Font DIMM	7-76
56P9942 Hard drive mounting kit	7-76
56P9975 Card assembly, Japanese font DIMM	7-76
56P9982 Hard disk, 20GB with/adapter (formatted)	7-76
7370235 Kit, relocation package assembly printer	7-77
7370563 Kit, relocation package assembly Output Expander	7-77
7370564 Kit, relocation package assembly 5-Bin Mailbox	7-77
7370565 Kit, relocation package assembly 500 Drawer	7-77
7370566 Kit, relocation package assembly Duplex	7-77
7370595 Kit, relocation package assembly Finisher	7-77
99A0052 Shaft assembly, lower exit, also order PP 99A0572	7-49
99A0070 Pick roll tires	7-57
99A0070 Pick rolls (2 each per package)	7-24
99A0104 Spring, upper diverter	7-49, 7-53
99A0107 Deflector, upper redrive, also order 99A0104	7-49
99A0263 Parts packet, screw, board mounting	7-53
99A0267 Parts packet, retainer	7-61
99A0323 Paper guide assembly	7-63
99A0351 Sensor, Output Expander pass thru	7-51
99A0361 Belt, 160 gear	7-51
99A0362 Arm assembly, belt idler	7-51
99A0363 Pulley, drive	7-51
99A0364 Spring, belt tensioner	7-51

99A0368 Shaft assembly, lower, also order PP 99A0572	7-51
99A0369 shaft assembly, exit, also order PP 99A0572	7-49
99A0408 INA blank flat shield, use when options are not installed	7-37
99A0409 Level sensor bracket	7-49
99A0414 Sensor, dual bin full	7-49
99A0415 Spring, swing arm	7-49
99A0424 Infrared adapter	7-76
99A0426 Screw, parallel connector mounting	7-37
99A0450 Retainer	7-55
99A0462 Grease packet, IBM #23	7-55
99A0481 Latch, output tray	7-49, 7-51
99A0482 Spring, output tray	7-49, 7-51
99A0545 External serial adapter	7-76
99A0560 Tri-Port Adapter - LocalTalk/serial/infrared	7-76
99A0572 Parts packet, shaft bearing	7-49, 7-51
99A0629 Coax/Twinax Adapter for SCS	7-76
99A0912 Frame assembly	7-51
99A0913 Shaft assembly, middle 40T, also order PP 99A0572	7-51
99A0915 Board, Output Expander DC motor	7-49
99A0923 Parallel port + USB INA card assembly	7-76
99A1580 Flag, output paper level	7-49
99A1611 Ethernet blank shield, use with non-network RIP boards	7-37
99A1687 Stop asm, paper tray	7-53
99A1688 Diverter arm	7-49
99A1689 Spring clutch assembly	7-49
99A1708 Cover, right side	7-53
99A1710 Cover, wire	7-53
99A1712 Tray, paper cap	7-53
99A1713 Support, paper tray	7-53
99A1715 Roller asm, rear access door	7-55
99A1716 Drive asm, main DC drive	7-53
99A1717 32 ppm drive gear	7-63
99A1717 Gear, drive	7-55
99A1718 Cable asm, lower autoconnect	7-53
99A1719 Cable asm, upper autoconnect	7-53
99A1721 Deflector, paper top bin	7-55
99A1722 Deflector, paper	7-55
99A1723 Shaft asm, drive	7-53
99A1724 Shaft asm, drive with gear	7-53
99A1725 Packet, drive shaft bushing	7-53
99A1726 Frame asm, left w/clutch asm	7-53
99A1727 Frame asm, right side	7-55
99A1728 Cam, diverter actuator	7-55
99A1729 Latch, diverter actuator	7-55
99A1730 Arbor, diverter actuator	7-55
99A1731 Spring, diverter actuator	7-55
99A1732 Solenoid, diverter	7-55
99A1735 Flag, bin full	7-53
99A1736 Cable, dual sensor	7-53
99A1737 Sensor, dual bin level	7-53
99A1738 Deflector, paper exit w/brush	7-55
99A1740 Board asm, 5-Bin Mailbox system	7-53
99A1741 Spring, diverter	7-55
99A1742 Sensor, 5-Bin Mailbox pass thru	7-53
99A1743 Kit, 5-Bin Mailbox asm	7-53
99A1744 Kit, Multi-Bin Stacker	7-51
99A1784 Bracket, attach	7-49

5060-00x

99A1786 Gear, drive	7-53
99A1787 Deflector	7-55
99A1788 Retainer, R-ring	7-55
99A1789 C-clip	7-55
99A1789 Retainer, C-clip	7-63
99A1817 Tray, Output Expander	7-49
99A2432 Blank parallel shield, use with network RIP boards	7-37
99A2540 Redrive bearing	7-61

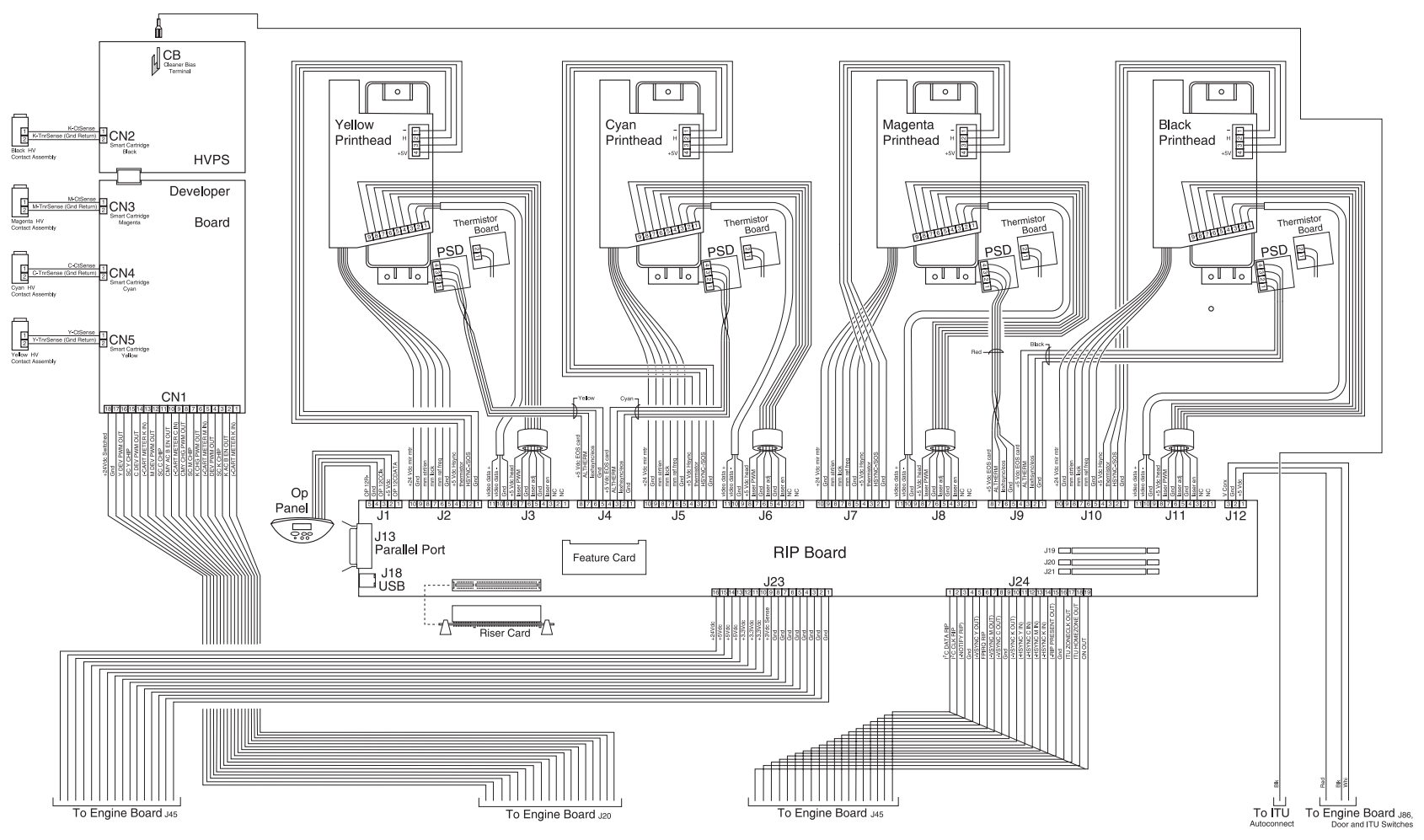

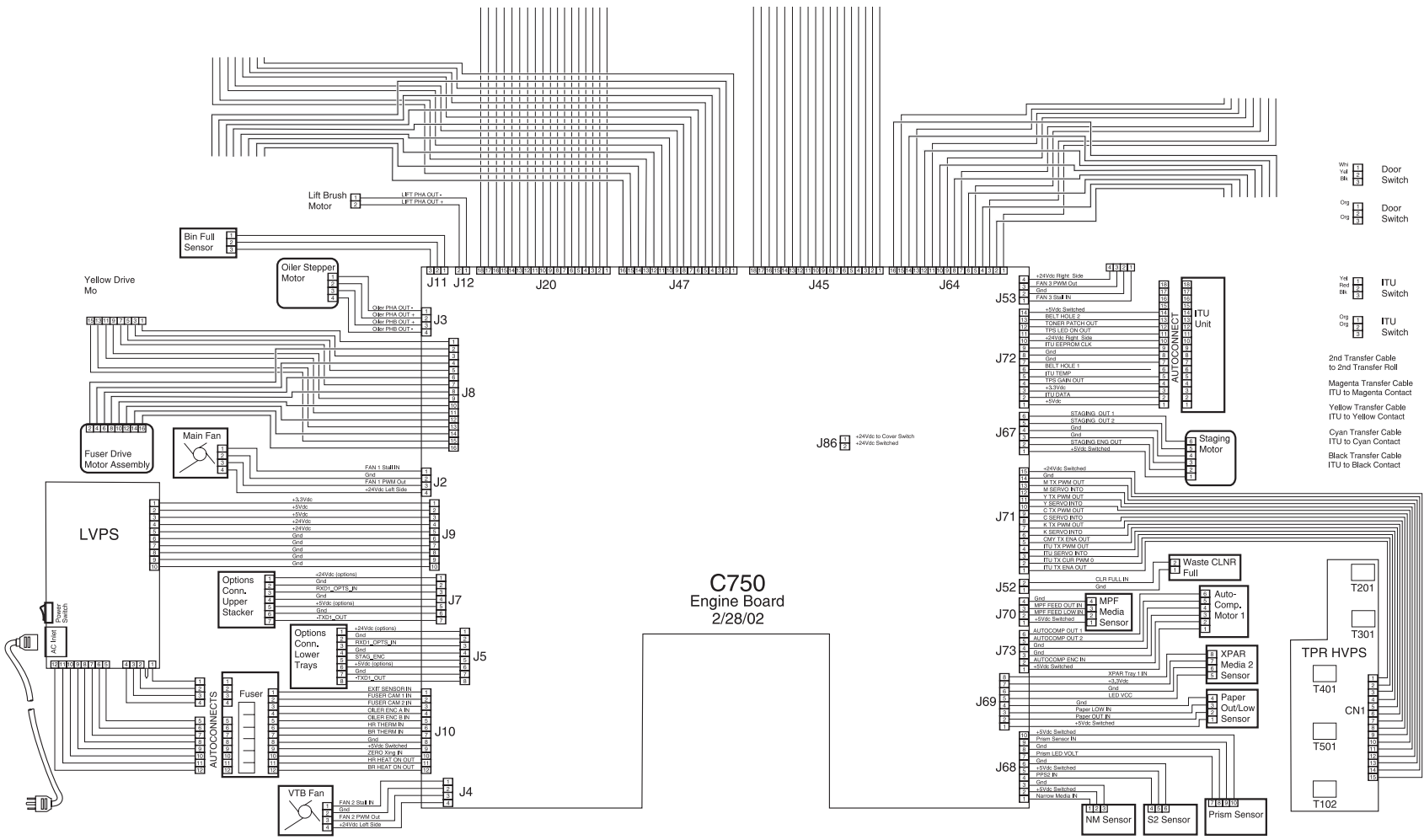

**C750
Engine Board
2/28/02**

W1
Yd
R1
R2

Door Switch

Og
Og

Door Switch

Yd
Rd
R1
R2

ITU Switch

Og
Og

ITU Switch

2nd Transfer Cable to 2nd Transfer Roll
Magenta Transfer Cable ITU to Magenta Contact
Yellow Transfer Cable ITU to Yellow Contact
Cyan Transfer Cable ITU to Cyan Contact
Black Transfer Cable ITU to Black Contact

T201
T301
TPR HVPS
T401
T501
CN1
T102

Option
Autoconnect

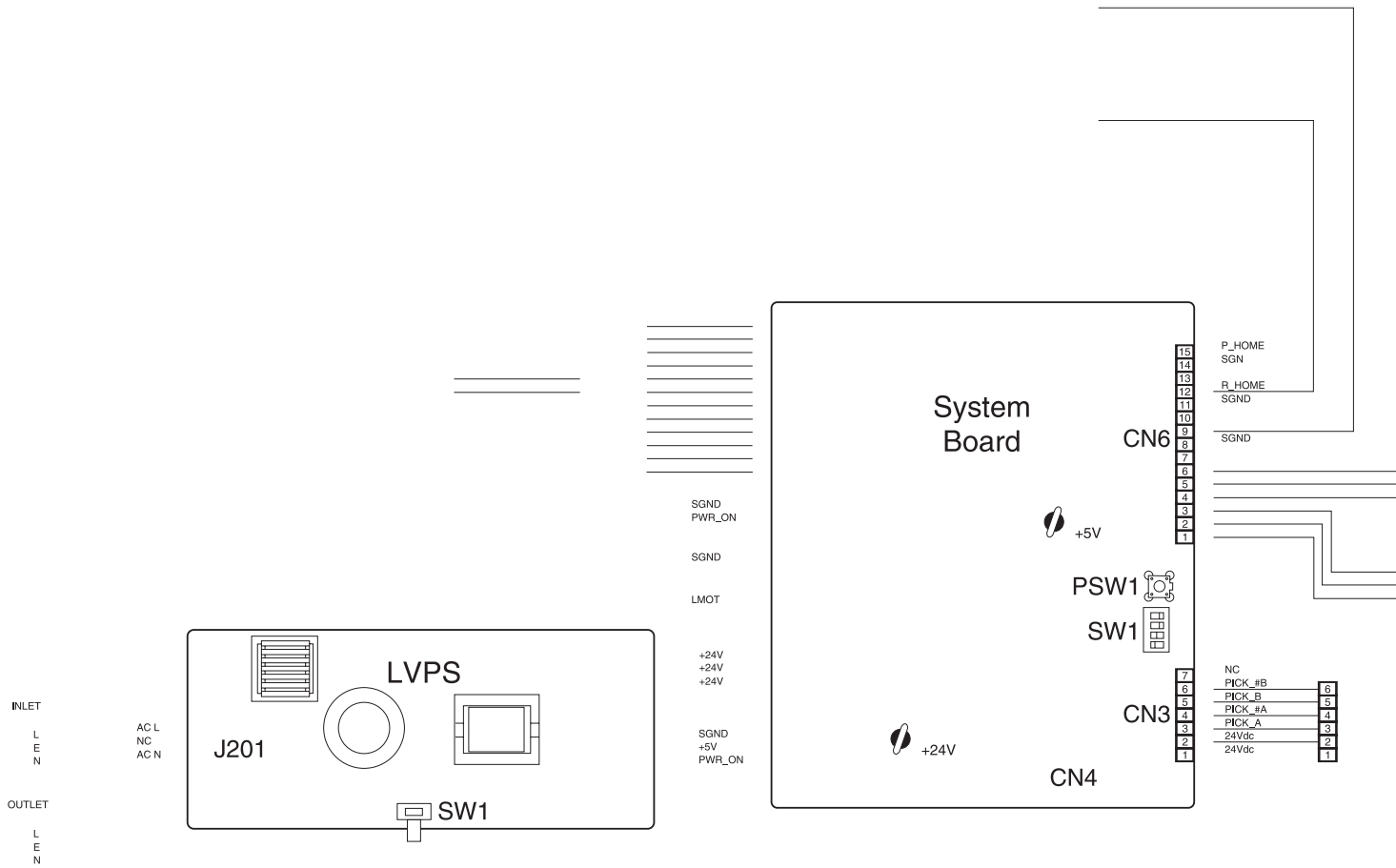

HCIT 2000 Sheet
Input Tray
Wiring Diagram

