



Service Manual

Lexmark X500n-X502n MFP

7100-XXX

- ***Table of contents***
- ***Start diagnostics***
- ***Safety and notices***
- ***Trademarks***
- ***Index***

LEXMARK™

Lexmark and Lexmark with diamond design are trademarks of Lexmark international, inc., registered in the United States and/or other countries.

Edition: November 12, 2007

The following paragraph does not apply to any country where such provisions are inconsistent with local law: LEXMARK INTERNATIONAL, inC. PROVIDES THIS PUBLICATION "AS IS" WITHOUT WARRANTY OF ANY KIND, EITHER EXPRESS OR IMPLIED, INCLUDING, BUT NOT LIMITED TO, THE IMPLIED WARRANTIES OF MERCHANTABILITY OR FITNESS FOR A PARTICULAR PURPOSE. Some states do not allow disclaimer of express or implied warranties in certain transactions; therefore, this statement may not apply to you.

This publication could include technical inaccuracies or typographical errors. Changes are periodically made to the information herein; these changes will be incorporated in later editions. Improvements or changes in the products or the programs described may be made at any time.

Comments may be addressed to Lexmark International, Inc., Department D22A/032-2, 740 West New Circle Road, Lexington, Kentucky 40550, U.S.A or e-mail at ServiceinfoAndTraining@Lexmark.com. Lexmark may use or distribute any of the information you supply in any way it believes appropriate without incurring any obligation to you.

References in this publication to products, programs, or services do not imply that the manufacturer intends to make these available in all countries in which it operates. Any reference to a product, program, or service is not intended to state or imply that only that product, program, or service may be used. Any functionally equivalent product, program, or service that does not infringe any existing intellectual property right may be used instead. Evaluation and verification of operation in conjunction with other products, programs, or services, except those expressly designated by the manufacturer, are the user's responsibility.

Lexmark, Lexmark with diamond design is a trademark of Lexmark international, inc., registered in the United States and/ or other countries.

All other trademarks are the property of their respective owners.

© 2007 Lexmark International, Inc.
All rights reserved.

UNITED STATES GOVERNMENT RIGHTS

This software and any accompanying documentation provided under this agreement are commercial computer software and documentation developed exclusively at private expense.

Table of contents

Notices and safety information	ix
Preface	xix
General information	1-1
Models	1-1
MFP Specifications	1-2
General device technical specifications	1-2
Print engine specifications	1-6
Scan specifications	1-10
Copy specifications	1-11
Fax specifications	1-11
Media guidelines	1-13
Maintenance approach	1-15
Standard inspection and cleaning procedure	1-15
Serial number	1-16
Tools required for service	1-16
Acronyms	1-17
Diagnostic information	2-1
Start	2-1
Understanding the operator panel	2-2
Service error codes	2-3
User status messages	2-6
User attendance messages	2-8
Symptom tables	2-11
MFP symptom table	2-11
Print quality symptom table	2-13
Printer service checks	2-14
Main motor service check	2-14
CPU fan service check	2-16
Developer drive assembly service check	2-16
Transfer belt unit service check	2-17
Transfer roller clutch service check	2-18
Transfer belt cleaning roller clutch service check	2-18
Paper feed clutch service check	2-19
Registration clutch service check	2-19
OPC belt marker sensor service check	2-20
Erase lamp service check	2-21
Power supply fan service check	2-22
Fuser fan service check	2-22
High voltage power supply (HVPS) service check	2-23
Low voltage power supply (LVPS) service check	2-23
Fuser thermistor service check	2-24
Fuser assembly service check	2-24
Laser unit assembly service check	2-25
HVPS connection service check	2-25
Toner empty sensor (sender-TPD) service check	2-26
Toner empty sensor (receiver-TTR) service check	2-27
Lower feed unit (secondary paper assembly) service check	2-28
Tray empty service check	2-29
Paper tray missing service check	2-30
Toner low/empty service check	2-31

Waste toner bottle service check	2-31
Missing toner cartridge service check	2-32
Missing photodeveloper cartridge service check	2-33
Transfer roller missing service check	2-34
Cover open service check	2-35
OPC belt (photodeveloper) cartridge drive service check	2-36
Missing fuser service check	2-36
Paper size sensing service check	2-37
Printer no power service check	2-38
Toner feed service check	2-39
Waste toner feed service check	2-39
Operator panel service check	2-40
USB service check	2-40
Network service check	2-40
Black page copy service check	2-41
Flatbed service check	2-41
ADF streak service check	2-41
ADF paper feed service check	2-42
Modem / fax card service check	2-43
Paper feed service checks	2-44
Printer paper feed service check	2-44
Print quality service checks	2-45
Background service check	2-45
Back stain service check	2-46
Banding service check	2-47
Black line service check	2-48
Color misregistration service check	2-49
insufficient fusing service check	2-50
insufficient gloss service check	2-51
Jitter service check	2-52
Missing image at edge service check	2-53
Mixed color image service check	2-54
Mottle service check	2-55
Residual image service check	2-56
Ribbing service check	2-57
Smear service check	2-58
Toner drop service check	2-59
Vertical line service check	2-60
Vertical staggering image service check	2-61
Vertical white band service check	2-62
White band service check	2-63
White line I service check	2-64
White line II service check	2-64
White spot / black spot service check	2-65
White print service check	2-66
Wrinkle / image migration service check	2-67
Uneven density (right and left)	2-68
Spacing table	2-69
Roller specifications	2-69
Diagnostic aids	3-1
Understanding the MFP operator panel	3-1
Retrieving, printing and restoring the MFP settings	3-3
Printing the maintenance and configuration pages	3-3
Setting the country code	3-3

Scanner calibration and registration	3-3
Maintenance mode	3-4
Display info	3-4
Print Reports	3-5
Engine maintenance	3-6
Scan Maintenance	3-6
Fax Maintenance	3-6
Density Tune Up	3-8
Printer theory of operation	3-9
Electrophotographic Process (EP process)	3-9
EP Basics	3-9
Summary of the EP process on the X500	3-10
X500 EP steps in detail	3-11
Printer Components	3-19
Paper path components	3-20
X500n specific information	3-20
Paper jam messages	3-22
Accessing jam areas	3-23
Paper Jam A1, rear (tray 1)	3-24
Paper Jam A2, rear (tray 2)	3-26
Paper Jam B rear	3-27
Paper Jam C rear	3-29
ADF paper jams	3-30
Repair information	4-1
Removal and cleaning precautions	4-1
Handling ESD-sensitive parts	4-2
..... Photodeveloper cartridge	4-3
During transportation/storage	4-3
Handling	4-3
MFP removals	4-4
Cleaning roller cover removal	4-4
Transfer belt cleaning roller removal	4-4
Transfer belt unit removal	4-5
Transfer roller removal	4-6
Fuser assembly removal	4-6
Waste toner bottle removal	4-7
Photodeveloper cartridge removal	4-8
Secondary paper feed assembly removal	4-9
Cover removals	4-10
Top cover assembly removal	4-10
Front cover assembly removal	4-12
Right cover removal	4-13
Rear cover assembly removal	4-14
Left front cover removal	4-15
Left rear cover removal	4-16
Upper right rear cover removal	4-17
Upper left rear cover removal	4-17
Laser unit assembly (printhead) removal	4-18
Erase lamp removal	4-20
Right side removals	4-21
Front door interlock switch with bracket	4-21
Waste toner bottle holder removal	4-22
Developer drive assembly removal	4-22
Toner sensor (sender) removal	4-24

Cleaning roller clutch removal	4-25
Main motor assembly removal	4-26
Clutch removal	4-27
Main drive gear assembly removal	4-27
Waste toner feeder removal	4-28
Rear removals	4-30
Bracket assembly removal	4-30
Paper guide assembly removal	4-31
Paper guide C assembly removal	4-31
Paper feed roller removal	4-32
Paper exit assembly removal	4-32
Registration assembly removal	4-33
Left side removals	4-34
Engine controller board removal	4-34
System board removal	4-36
System board cage removal	4-39
High voltage power supply (HVPS) removal	4-40
Low voltage power supply (LVPS) with cage removal	4-41
HVPS cage removal	4-42
Toner present sensor removal	4-42
Toner sensor (receiver) removal	4-43
Left tray guide assembly removal	4-43
Modem speaker removal	4-44
Fuser fan assembly removal	4-44
Modem card removal	4-46
Top removals	4-47
Marker sensor assembly removal	4-47
Waste toner auger removal	4-48
Waste toner agitator removal	4-48
Power supply fan removal	4-49
Scanner assembly removals	4-50
Flatbed assembly removal	4-50
Scanner arm removal	4-53
ADF unit removal	4-54
ADF mechanism cover removal	4-56
Operator panel removal	4-58
Locations and connectors	5-1
Printer front and rear views	5-1
Scanner locations	5-3
Electronic components	5-4
Printer engine sensor locations	5-4
MFP circuit board locations	5-5
Fan/motor and interlock switch locations	5-6
Clutch locations	5-7
Symbol and part name table	5-8
Engine controller board wiring diagram	5-9
RIP board	5-15
RIP card voltages	5-15
Engine controller board	5-16
Low voltage power supply (LVPS) board	5-16
High voltage power supply (HVPS) board	5-17
Modem Card voltages and signals	5-18
Preventive maintenance	6-1

Parts catalog 7-1
 How to use this parts catalog 7-1
Index I-1
Part number index I-9

Notices and safety information

The following laser notice labels may be affixed to this printer.

Laser notice

The printer is certified in the U.S. to conform to the requirements of DHHS 21 CFR Subchapter J for Class I (1) laser products, and elsewhere is certified as a Class I laser product conforming to the requirements of IEC 60825-1.

Class I laser products are not considered to be hazardous. The printer contains internally a Class IIIb (3b) laser that is nominally a 5 milliwatt gallium arsenide laser operating in the wavelength region of 770-795 nanometers. The laser system and printer are designed so there is never any human access to laser radiation above a Class I level during normal operation, user maintenance, or prescribed service condition.

Laser

Der Drucker erfüllt gemäß amtlicher Bestätigung der USA die Anforderungen der Bestimmung DHHS (Department of Health and Human Services) 21 CFR Teil J für Laserprodukte der Klasse I (1). In anderen Ländern gilt der Drucker als Laserprodukt der Klasse I, der die Anforderungen der IEC (international Electrotechnical Commission) 60825-1 gemäß amtlicher Bestätigung erfüllt.

Laserprodukte der Klasse I gelten als unschädlich. Im Inneren des Druckers befindet sich ein Laser der Klasse IIIb (3b), bei dem es sich um einen Galliumarsenlaser mit 5 Milliwatt handelt, der Wellen der Länge 770-795 Nanometer ausstrahlt. Das Lasersystem und der Drucker sind so konzipiert, daß im Normalbetrieb, bei der Wartung durch den Benutzer oder bei ordnungsgemäßer Wartung durch den Kundendienst Laserbestrahlung, die Klasse I übersteigen würde, Menschen keinesfalls erreicht.

Avis relatif à l'utilisation de laser

Pour les Etats-Unis : cette imprimante est certifiée conforme aux provisions DHHS 21 CFR alinéa J concernant les produits laser de Classe I (1). Pour les autres pays : cette imprimante répond aux normes IEC 60825-1 relatives aux produits laser de Classe I.

Les produits laser de Classe I sont considérés comme des produits non dangereux. Cette imprimante est équipée d'un laser de Classe IIIb (3b) (arséniure de gallium d'une puissance nominale de 5 milliwatts) émettant sur des longueurs d'onde comprises entre 770 et 795 nanomètres. L'imprimante et son système laser sont conçus pour impossible, dans des conditions normales d'utilisation, d'entretien par l'utilisateur ou de révision, l'exposition à des rayonnements laser supérieurs à des rayonnements de Classe I.

Avvertenze sui prodotti laser

Questa stampante è certificata negli Stati Uniti per essere conforme ai requisiti del DHHS 21 CFR Sottocapitolo J per i prodotti laser di classe 1 ed è certificata negli altri Paesi come prodotto laser di classe 1 conforme ai requisiti della norma CEI 60825-1.

I prodotti laser di classe non sono considerati pericolosi. La stampante contiene al suo interno un laser di classe IIIb (3b) all'arseniuro di gallio della potenza di 5mW che opera sulla lunghezza d'onda compresa tra 770 e 795 nanometri. Il sistema laser e la stampante sono stati progettati in modo tale che le persone a contatto con la stampante, durante il normale funzionamento, le operazioni di servizio o quelle di assistenza tecnica, non ricevano radiazioni laser superiori al livello della classe 1.

Avisos sobre el láser

Se certifica que, en los EE.UU., esta impresora cumple los requisitos para los productos láser de Clase I (1) establecidos en el subcapítulo J de la norma CFR 21 del DHHS (Departamento de Sanidad y Servicios) y, en los demás países, reúne todas las condiciones expuestas en la norma IEC 60825-1 para productos láser de Clase I (1).

Los productos láser de Clase I no se consideran peligrosos. La impresora contiene en su interior un láser de Clase IIIb (3b) de arseniuro de galio de funcionamiento nominal a 5 milivatios en una longitud de onda de 770 a 795 nanómetros. El sistema láser y la impresora están diseñados de forma que ninguna persona pueda verse afectada por ningún tipo de radiación láser superior al nivel de la Clase I durante su uso normal, el mantenimiento realizado por el usuario o cualquier otra situación de servicio técnico.

Declaração sobre Laser

A impressora está certificada nos E.U.A. em conformidade com os requisitos da regulamentação DHHS 21 CFR Subcapítulo J para a Classe I (1) de produtos laser. Em outros locais, está certificada como um produto laser da Classe I, em conformidade com os requisitos da norma IEC 60825-1.

Os produtos laser da Classe I não são considerados perigosos. internamente, a impressora contém um produto laser da Classe IIIb (3b), designado laser de arseneto de potássio, de 5 milliwatts, operando numa faixa de comprimento de onda entre 770 e 795 nanómetros. O sistema e a impressora laser foram concebidos de forma a nunca existir qualquer possibilidade de acesso humano a radiação laser superior a um nível de Classe I durante a operação normal, a manutenção feita pelo utilizador ou condições de assistência prescritas.

Laserinformatie

De printer voldoet aan de eisen die gesteld worden aan een laserproduct van klasse I. Voor de Verenigde Staten zijn deze eisen vastgelegd in DHHS 21 CFR Subchapter J, voor andere landen in IEC 60825-1.

Laserprodukten van klasse I worden niet als ongevaarlijk aangemerkt. De printer is voorzien van een laser van klasse IIIb (3b), dat wil zeggen een gallium arsenide-laser van 5 milliwatt met een golflengte van 770-795 nanometer. Het lasergedeelte en de printer zijn zo ontworpen dat bij normaal gebruik, bij onderhoud of reparatie conform de voorschriften, nooit blootstelling mogelijk is aan laserstraling boven een niveau zoals voorgeschreven is voor klasse 1.

Lasermeddelelse

Printeren er godkendt som et Klasse I-laserprodukt, i overensstemmelse med kravene i IEC 60825-1.

Klasse I-laserprodukter betragtes ikke som farlige. Printeren indeholder internt en Klasse IIIB (3b)-laser, der nominelt er en 5 milliwatt galliumarsenid laser, som arbejder på bølgelængdeområdet 770-795 nanometer. Lasersystemet og printeren er udformet således, at mennesker aldrig udsættes for en laserstråling over Klasse I-niveau ved normal drift, brugervedligeholdelse eller obligatoriske servicebetingelser.

Laserilmoitus

Tämä tulostin on sertifioitu Yhdysvalloissa DHHS 21 CFR Subchapter J -standardin mukaiseksi luokan I (1) - lasertuotteeksi ja muualla IEC 60825-1 -standardin mukaiseksi luokan I lasertuotteeksi.

Luokan I lasertuotteita ei pidetä haitallisina. Tulostimen sisällä on luokan IIIb (3b) laser, joka on nimellisteholtaan 5 mW:n galliumarsenidilaser ja toimii 770 - 795 nanometrin aallonpituuksilla. Laserjärjestelmä ja tulostin ovat rakenteeltaan sellaisia, että käyttäjä ei joudu alttiiksi luokkaa 1 suuremmalle säteilylle normaalin käytön, ylläpidon tai huollon aikana.

Huomautus laserlaitteesta

Tämä kirjoitin on Yhdysvalloissa luokan I (1) laserlaitteiden DHHS 21 CFR Subchapter J -määrityksen mukainen ja muualla luokan I laserlaitteiden IEC 60825-1 -määrityksen mukainen.

Luokan I laserlaitteiden ei katsota olevan vaarallisia käyttäjälle. Kirjoittimessa on sisäinen luokan IIIb (3b) 5 milliwatin galliumarsenidilaser, joka toimii aaltoalueella 770 - 795 nanometriä. Laserjärjestelmä ja kirjoitin on suunniteltu siten, että käyttäjä ei altistu luokan I määräytyksiä voimakkaammalle säteilylle kirjoittimen normaalin toiminnan, käyttäjän tekemien huoltotoimien tai muiden huoltotoimien yhteydessä.

VARO! Avattaessa ja suojalukitus ohitettaessa olet alttiina näkymättömälle lasersäteilylle. Älä katso säteeseen.

VARNIN! Osynlig laserstrålning när denna del är öppnad och spårren är urkopplad. Betrakta ej strålen.

Laser-notis

Denna skrivare är i USA certifierad att motsvara kraven i DHHS 21 CFR, underparagraf J för laserprodukter av Klass I (1). I andra länder uppfyller skrivaren kraven för laserprodukter av Klass I enligt kraven i IEC 60825-1.

Laserprodukter i Klass I anses ej hälsovådliga. Skrivaren har en inbyggd laser av Klass IIIb (3b) som består av en laserenhet av gallium-arsenid på 5 milliwatt som arbetar i våglängdsområdet 770-795 nanometer. Lasersystemet och skrivaren är utformade så att det aldrig finns risk för att någon person utsätts för laserstrålning över Klass I-nivå vid normal användning, underhåll som utförs av användaren eller annan föreskriven serviceåtgärd.

Laser-melding

Skriveren er godkjent i USA etter kravene i DHHS 21 CFR, underkapittel J, for klasse I (1) laserprodukter, og er i andre land godkjent som et Klasse I-laserprodukt i samsvar med kravene i IEC 60825-1.

Klasse I-laserprodukter er ikke å betrakte som farlige. Skriveren inneholder internt en klasse IIIb (3b)-laser, som består av en gallium-arsenlaserenhet som avgir stråling i bølgelengdeområdet 770-795 nanometer. Lasersystemet og skriveren er utformet slik at personer aldri utsettes for laserstråling ut over klasse I-nivå under vanlig bruk, vedlikehold som utføres av brukeren, eller foreskrevne serviceoperasjoner.

Avís sobre el Làser

Segons ha estat certificat als Estats Units, aquesta impressora compleix els requisits de DHHS 21 CFR, apartat J, pels productes làser de classe I (1), i segons ha estat certificat en altres llocs, és un producte làser de classe I que compleix els requisits d'IEC 60825-1.

Els productes làser de classe I no es consideren perillosos. Aquesta impressora conté un làser de classe IIIb (3b) d'arseniür de gal.li, nominalment de 5 mil.liwats, i funciona a la regió de longitud d'ona de 770-795 nanòmetres. El sistema làser i la impressora han sigut concebuts de manera que mai hi hagi exposició a la radiació làser per sobre d'un nivell de classe I durant una operació normal, durant les tasques de manteniment d'usuari ni durant els serveis que satisfacin les condicions prescrites.

レーザーに関するお知らせ

このプリンターは、米国ではDHHS 21 CFRサブチャプターJのクラスI (1)の基準を満たしたレーザー製品であることが証明されています。また米国以外ではIEC 825の基準を満たしたクラスIのレーザー製品であることが証明されています。

クラスIのレーザー製品には危険性はないと考えられています。このプリンターはクラスIIIb (3b)のレーザーを内蔵しています。このレーザーは、波長が770 ~ 795ナノメートルの範囲で、通常5ミリワットのガリウム砒化物を放射するレーザーです。このレーザーシステムとプリンターは、通常の操作、ユーザのメンテナンス、規定された修理においては、人体がクラスIのレベル以上のレーザー放射に晒されることのないよう設計されています。

注意：

本打印机被美国认证合乎 DHHS 21 CFR Subchapter I 对分类 I (1) 激光产品的标准，而在其他地区则被认证合乎 IEC 825 的标准。

分类 I 激光产品一般认为不具危险性，本打印机内部含有分类 IIIb (3b) 的激光，在操作过程中会产生 5 毫瓦含镓及砷的微量激光，其波长范围在 770-795 nm 之间。本激光系统及打印机的设计，在一般操作、使用者维护或规定内的维修情况下，不会使人体接触分类 I 以上等级的辐射。

본프린터는 1등급 레이저 제품들에 대한 DHHS 21 CFR Subchapter 3의 규정을 준수하고 있음을 미국에서 인증받았으며, 그외의 나라에서도 IEC 825 규정을 준수하는 1등급 레이저 제품으로서 인증을 받았습니다.

1등급 레이저 제품들은 안전한 것으로 간주됩니다. 본 프린터는 5 밀리와트 갈륨 아르세나이드 레이저로서 770-795 나노미터의 파장대에서 활동하는 Class III (3b) 레이저를 내부에 갖고 있습니다. 본 레이저 시스템과 프린터는 정상 작동 중이나 유지 보수 중 또는 규정된 서비스 상태에서 상기의 Class I 수준의 레이저 방출에 사람이 절대 접근할 수 없도록 설계되어 있습니다.

Safety information

- The safety of this product is based on testing and approvals of the original design and specific components. The manufacturer is not responsible for safety in the event of use of unauthorized replacement parts.
- The maintenance information for this product has been prepared for use by a professional service person and is not intended to be used by others.
- There may be an increased risk of electric shock and personal injury during disassembly and servicing of this product. Professional service personnel should understand this and take necessary precautions.
-  **CAUTION:** When you see this symbol, there is a danger from hazardous voltage in the area of the product where you are working. Unplug the product before you begin, or use caution if the product must receive power in order to perform the task.

Consignes de sécurité

- La sécurité de ce produit repose sur des tests et des agrégations portant sur sa conception d'origine et sur des composants particuliers. Le fabricant n'assume aucune responsabilité concernant la sécurité en cas d'utilisation de pièces de rechange non agréées.
- Les consignes d'entretien et de réparation de ce produit s'adressent uniquement à un personnel de maintenance qualifié.
- Le démontage et l'entretien de ce produit pouvant présenter certains risques électriques, le personnel d'entretien qualifié devra prendre toutes les précautions nécessaires.
-  **ATTENTION :** Ce symbole indique la présence d'une tension dangereuse dans la partie du produit sur laquelle vous travaillez. Débranchez le produit avant de commencer ou faites preuve de vigilance si l'exécution de la tâche exige que le produit reste sous tension.

Norme di sicurezza

- La sicurezza del prodotto si basa sui test e sull'approvazione del progetto originale e dei componenti specifici. Il produttore non è responsabile per la sicurezza in caso di sostituzione non autorizzata delle parti.
- Le informazioni riguardanti la manutenzione di questo prodotto sono indirizzate soltanto al personale di assistenza autorizzato.
- Durante lo smontaggio e la manutenzione di questo prodotto, il rischio di subire scosse elettriche e danni alla persona è più elevato. Il personale di assistenza autorizzato deve, quindi, adottare le precauzioni necessarie.
-  **ATTENZIONE:** Questo simbolo indica la presenza di tensione pericolosa nell'area del prodotto. Scollegare il prodotto prima di iniziare o usare cautela se il prodotto deve essere alimentato per eseguire l'intervento.

Sicherheitshinweise

- Die Sicherheit dieses Produkts basiert auf Tests und Zulassungen des ursprünglichen Modells und bestimmter Bauteile. Bei Verwendung nicht genehmigter Ersatzteile wird vom Hersteller keine Verantwortung oder Haftung für die Sicherheit übernommen.
- Die Wartungsinformationen für dieses Produkt sind ausschließlich für die Verwendung durch einen Wartungsfachmann bestimmt.
- Während des Auseinandernehmens und der Wartung des Geräts besteht ein zusätzliches Risiko eines elektrischen Schlags und körperlicher Verletzung. Das zuständige Fachpersonal sollte entsprechende Vorsichtsmaßnahmen treffen.
-  **ACHTUNG:** Dieses Symbol weist auf eine gefährliche elektrische Spannung hin, die in diesem Bereich des Produkts auftreten kann. Ziehen Sie vor den Arbeiten am Gerät den Netzstecker des Geräts, bzw. arbeiten Sie mit großer Vorsicht, wenn das Produkt für die Ausführung der Arbeiten an den Strom angeschlossen sein muß.

Pautas de Seguridad

- La seguridad de este producto se basa en pruebas y aprobaciones del diseño original y componentes específicos. El fabricante no es responsable de la seguridad en caso de uso de piezas de repuesto no autorizadas.
- La información sobre el mantenimiento de este producto está dirigida exclusivamente al personal cualificado de mantenimiento.
- Existe mayor riesgo de descarga eléctrica y de daños personales durante el desmontaje y la reparación de la máquina. El personal cualificado debe ser consciente de este peligro y tomar las precauciones necesarias.
-  **PRECAUCIÓN:** este símbolo indica que el voltaje de la parte del equipo con la que está trabajando es peligroso. Antes de empezar, desenchufe el equipo o tenga cuidado si, para trabajar con él, debe conectarlo.

Informações de Segurança

- A segurança deste produto baseia-se em testes e aprovações do modelo original e de componentes específicos. O fabricante não é responsável pela segurança, no caso de uso de peças de substituição não autorizadas.
- As informações de segurança relativas a este produto destinam-se a profissionais destes serviços e não devem ser utilizadas por outras pessoas.
- Risco de choques eléctricos e ferimentos graves durante a desmontagem e manutenção deste produto. Os profissionais destes serviços devem estar avisados deste facto e tomar os cuidados necessários.
-  **CUIDADO:** Quando vir este símbolo, existe a possível presença de uma potencial tensão perigosa na zona do produto em que está a trabalhar. Antes de começar, desligue o produto da tomada eléctrica ou seja cuidadoso caso o produto tenha de estar ligado à corrente eléctrica para realizar a tarefa necessária.

Informació de Seguretat

- La seguretat d'aquest producte es basa en l'avaluació i aprovació del disseny original i els components específics.
El fabricant no es fa responsable de les qüestions de seguretat si s'utilitzen peces de recanvi no autoritzades.
- La informació pel manteniment d'aquest producte està orientada exclusivament a professionals i no està destinada a ningú que no ho sigui.
- El risc de xoc elèctric i de danys personals pot augmentar durant el procés de desmuntatge i de servei d'aquest producte. El personal professional ha d'estar-ne assabentat i prendre les mesures convenients.
-  **PRECAUCIÓ:** aquest símbol indica que el voltatge de la part de l'equip amb la qual esteu treballant és perillós. Abans de començar, desendolieu l'equip o extremeu les precaucions si, per treballar amb l'equip, l'heu de connectar.

안전 사항

- 본 제품은 원래 설계 및 특정 구성품에 대한 테스트 결과로 안정성이 입증된 것입니다. 따라서 무허가 교체부품을 사용하는 경우에는 제조업체에서 안전에 대한 책임을 지지 않습니다.
- 본 제품에 관한 유지 보수 설명서는 전문 서비스 기술자용으로 작성된 것이므로, 비전문가는 사용할 수 없습니다.
- 본 제품을 해체하거나 정비할 경우, 전기적인 충격을 받거나 상처를 입을 위험이 커집니다. 전문 서비스 기술자는 이 사실을 숙지하고, 필요한 예방 조치를 취하도록 하십시오.
-  **주의:** 이 표시는 해당영역에서 고압전류가 흐른다는 위험 표시입니다. 시작전에 플러그를 뽑으시거나, 주의를 기울여 주시기 바랍니다.

安全信息

- 本产品的安全性以原来设计和特定产品的测试结果和认证为基础。万一使用未经许可的替换部件，制造商不对安全性负责。
- 本产品的维护信息仅供专业服务人员使用，并不打算让其他人使用。
- 本产品在拆卸、维修时，遭受电击或人员受伤的危险性会增高，专业服务人员对这点必须有所了解，并采取必要的预防措施。
-  **切记:** 当您看到此符号时，说明在您工作的产品区域有危险电压的存在。请在开始操作前拔掉产品的电源线，或者在产品必须使用电源来执行任务时，小心从事。

Lithium information



CAUTION: There is a lithium battery on your system board. **RISK OF EXPLOSION IF REPLACED BY INCORRECT TYPE.** The battery is non-replaceable. Do not replace, recharge, disassemble, or incinerate a lithium battery. Discard used batteries according to the manufacturer's instructions and local regulations.

Lithium-Information



ACHTUNG: Auf Ihrer Systemplatine befindet sich eine Lithiumbatterie. Beim Einsetzen eines nicht passenden Batterietyps besteht ein Explosionsrisiko. Die Batterie darf nicht ausgetauscht werden. Lithiumbatterien dürfen auf keinen Fall ausgetauscht, wieder aufgeladen, auseinander genommen oder verbrannt werden. Befolgen Sie zum Entsorgen verbrauchter Batterien die Anweisungen des Herstellers und die örtlichen Bestimmungen.

Preface

This manual contains maintenance procedures for service personnel. It is divided into the following chapters:

1. **General information** contains a general description of the printer and the maintenance approach used to repair it. Special tools and test equipment, as well as general environmental and safety instructions, are discussed.
 2. **Diagnostic information** contains an error indicator table, symptom tables, and service checks used to isolate failing field replaceable units (FRUs).
 3. **Diagnostic aids** contains tests and checks used to locate or repeat symptoms of printer problems.
 4. **Repair information** provides instructions for making printer adjustments and removing and installing FRUs.
 5. **Connector locations** uses illustrations to identify the connector locations and test points on the printer.
 6. **Preventive maintenance** contains the lubrication specifications and recommendations to prevent problems.
 7. **Parts catalog** contains illustrations and part numbers for individual FRUs.
- Appendix A** contains service tips and information.
Appendix B contains representative print samples.

Conventions

Note: A note provides additional information.

Warning: A warning identifies something that might damage the product hardware or software.

There are several types of caution statements:

	<p>CAUTION</p> <p>A caution identifies something that might cause a servicer harm.</p>
---	---

	<p>CAUTION</p> <p>This type of caution indicates there is a danger from hazardous voltage in the area of the product where you are working. Unplug the product before you begin, or use caution if the product must receive power in order to perform the task.</p>
---	--

	<p>CAUTION</p> <p>This type of caution indicates a hot surface.</p>
---	--

	<p>CAUTION</p> <p>This type of caution indicates a tipping hazard.</p>
---	---

7100-XXX

1. General information

The Lexmark™ X500n and X502n are color laser MFPs that combine print, scan, copy, and fax functions. The X500n and X502n are the ideal MFPs for presentations, business graphics, line art, and text. They use laser diode electrophotographic technology to deliver remarkable quality print images and text. The scan and copy functions work with A4 , letter, and legal (ADF only) size paper. Photographic quality images are possible with scan function. The FAX function delivers a wide range of functionality to the office user. The MFPs can be used as shared network or desktop devices.

Models

The Lexmark X5xx MFPs are available in the following models:

Model	Configuration	Machine type
X500n	Print, copy, scan, network	7100-010
X502n	Print, copy, scan, fax, network	7100-110

MFP Specifications

General device technical specifications

Interfaces

	X500n	X502n
USB 2.0	X	X
Ethernet 10/100 Base T	X	X

Note: The USB 2.0 and network interfaces can be used simultaneously.

The USB interface supports:

- Windows 98 SE
- Windows Me
- Windows NT
- Windows 2000 Professional
- Windows XP Operating Systems
- Windows Server 2003 Operating Systems
- Windows Vista 32/64 bit
- Macintosh OS X version 10.1–10.4 (Power PC and Intel)

Note: For USB attachment, a USB cable (P/N 12A2405) is recommended and must be ordered separately.

The standard Ethernet connection and optional N2100 Series print servers support the following protocols:

- TCP/IP– The TCP/IP standard set of application services are supported including DHCP, BOOTP, WINS, SNMP (MIB-2, host resources MIB, printer MIB, enterprise MIB, SNMP traps), HTTP, LPR/LPD, FTP, IPP1, SLP, DDNS
- AppleTalk

This MFP with standard Ethernet supports an Embedded Web Server. The current status of the operator panel is viewable using the resident Web pages.

Processor

ARM-11 core running at 366mhz.

Supported operating systems

This MFP is compatible with applications running under the following operating systems for either local or network connections:

Macintosh

- Macintosh OS X version 10.2–10.4 and above. (Power PC and Intel)

The software applications that operate with most Apple LaserWriter printers will generally operate with this printer.

Download the latest Lexmark printer PPD files or printer drivers from www.lexmark.com.

Microsoft Windows

- Microsoft Windows Me
- Microsoft Windows 2000 Professional
- Microsoft Windows 2000 Server
- Microsoft Windows 2000 Advanced Server
- Microsoft Windows XP Home
- Microsoft Windows XP Professional
- Microsoft Windows Server 2003
- Microsoft Windows Vista 32/64 bit

Download the latest printer drivers from <http://www.lexmark.com>.

The Windows software applications, which operate in the operating systems listed above, are best suited to run with the drivers supplied with this MFP. The drivers for Windows take advantage of the MFP's functions and increase the MFP's performance wherever possible.

Memory configuration

Standard DRAM	128MB
Optional SDRAM	N/A
Max DRAM	128MB

Physical specifications and weight (WIP)

The following table contains the dimensions and weights for each MFP model and option. This does not include packaging but does include the print cartridge that ships with the MFP.

	Width	Depth	Height	Weight ²
	inch	inch	inch	lb
	mm	mm	mm	kg
MFP				
Lexmark X500n/ X502n ¹	18.9	17.2	21	77.0
	480	437	531	35.0
Paper options				
530-Sheet drawer	18.1	18.5	7.3	13.3
	460	470	185	6.0
530-Sheet tray	11.2	14.4	4.5	4.2
	285	365	115	1.9
Standard tray	10.8	13.0	2.2	2.2
	275	330	55	1.0
Tray set to legal	10.8	15.9	2.2	2.4
	275	405	55	1.1
¹ Comes with standard input tray and starter cartridges.				
² Weight does not include packaging or pubs.				

Operating clearances

MFP sides	X5xxn	X5xxn with 530-sheet tray
Left side	8 in (203 mm)	8 in (203 mm)
Right side	20 in (508 mm)	20 in (508 mm)
Front	28 in (711 mm)	28 in (700 mm)
Rear	10 in (254 mm)	10 in (254 mm)
Top	16 in (400 mm)	16 in (400 mm)

Packaging and shipping dimensions

	Width	Depth	Height	Weight
MFP*	in	in	in	lb
	mm	mm	mm	kg
X500n / X502n	23.4	22.6	29.9	77
	595	575	760	42.0
Options				
530-Sheet drawer	21.9	22.4	10.9	18.7
	556	570	277	8.5
* Includes start-up kit (supplies)				

Power and electrical specifications

Printing states	X5xxn
Off	0 W
Average power while operating	
Continuous printing	670 W
Power consumption, standby	
Power saver on	35 W
Power saver off	200 W
Maximum current while operating	
115 Volts	11 A
230 Volts	6 A
Average current while operating	
115 Volts	6.0 A
230 Volts	3.0 A

Environment

Environment	Specifications
Operating	
Air temperature—product operating	10 to 32.5°C (50 to 90.5°F)
Air temperature—product power off	5 to 35°C (41 to 95°F)
Air relative humidity	15 to 80%
Altitude	0–2,500 m (0–8,200 ft.)
Ship / Storage	
Temperature—printer and supplies	0 to 35°C (32 to 95°F)*
Relative humidity	10 to 90% RH
Atmospheric pressure	613 to 1607 hPa (460 to 800 mm Hg)
*Severe High 35 to 40°C (95 to 104°F), Severe Low -10 to 0°C (14 to 32°F). The period under severe shall not be deemed to be continuous, but rather a total of such intermittent periods (48 hours at most for any one period).	

Print engine specifications

Print engine resolution

600 x 600 dpi, 1200 x 600 dpi

Color balance settings

This MFP offers color balance control. It is a color correction option that allows you to increase or decrease the amount of toner going to the page for all four color planes. The scale ranges from -10 to +10.

Emulations

Raster Graphics (CMYK bi-tone JBIG Compressed)

Print engine speed and performance

Media size	Pages/minute)	
	Standard tray	
	Mono	Color
Letter	Up to 31	Up to 8
A4	Up to 31	Up to 8
Legal	Up to 16	Up to 8
Transparencies	Up to 3	Up to 2
Thick card stock	Up to 3	Up to 2
Labels (letter & A4)	Up to 5	Up to 3
Medium thick card stock (letter & A4)	Up to 4	Up to 3
Envelopes	Up to 5	Up to 3

Print engine time to first print

Media type/Media size	First print time	
	Mono	Color
Plain paper mode / A4, letter	13 seconds	19 seconds
Transparency mode / A4, letter	23 seconds	29 seconds
Label–middle thickness stock / A4, letter	17 seconds	23 seconds
Middle thick stock–glossy / A4, letter	16 seconds	22 seconds
Thick stock / A4, letter	23 seconds	29 seconds
Envelope (1) mode / Commercial #10, International DL	18 seconds	24 seconds
Envelope (2) mode / Commercial #10, International DL	23 seconds	29 seconds
<p>Note: Note: Time to first page (TTFP) is the time from the moment when the host sends the print signal until the moment the trailing edge of the first page leaves the exit feed rollers. TTFP is measured using a simple text (single character) page.</p>		
<p>Note: Note: Warm up time, 60 seconds maximum, is the time elapsed from when the power is turned on to when the Ready status is reached.</p>		

Print engine paper and media specifications

Print area

The printable area is up to 4.0 mm (0.158 in) from the top and bottom of the media, and up to 3.0 mm (0.118 in) from the left and right edges. Any information placed outside this specified printable area will not print. For envelopes, the printable area is up to 4.0 mm (0.158 in) of the left and right edges, and 3.0 mm (0.118 in) of the top and bottom edges.

Print engine input and output configurations

The following table shows the standard number of input sources and output destinations, as well as the estimated capacity of each. Capacity may vary and is subject to media specifications and MFP operating environment. The capacities listed are based on plain paper at 75 g/m².

Sources and capacities	X500n / X502n
Input sources	
Number of standard sources	1
Number of optional input drawers	1
Maximum number of input sources ¹	2
Maximum input capacity	780
Input capacities ²	
Standard input	
Primary tray capacity	250
Total standard capacity	250
Optional input	
Optional tray 1 capacity	250
Optional tray 2 capacity	530
Output destinations	
Number of standard destinations	1
Output capacities	
Standard output bin capacity (top)	
Media up to 20 lb paper	250
¹ Optional input drawer is a 530-sheet capacity drawer. Only one optional drawer may be installed at any time.	
² The MFP supports top output (facedown) as standard. No additional output options are available.	
Note: All capacities are based on use of 20 lb paper.	

Media input types and weights

Source	Type	Standard tray Legal tray	530-Sheet tray	MFP menu Item	
				Paper type	Paper weight
Paper ^{1,2} (grain long)	Xerographic or bond paper	60-74 g/m ² (16-19 lb)	60-74 g/m ² (16-19 lb)	Plain paper	Light
	Xerographic or bond paper	75-120 g/m ² (20-32 lb)	75-120 g/m ² (20-32 lb)	Plain paper	Normal
	100% Cotton	75-120 g/m ² (24-32 lb)	75-120 g/m ² (24-32 lb)	Plain paper	Heavy
Card stock	Index	163 g/m ² (90 lb)	N/A	Card stock	Normal
	Index	164-210 g/m ² (91-110 lb)	N/A	Card stock	Heavy
Transparency ³		PN 12A5940 PN 12A5941	N/A	Transparency	
Labels ²			N/A	Label	
Envelopes		75-90 g/m ² (20-24lb)	N/A	Envelope	Normal
¹ Punched, embossed, water-marked, perforated, punched, inkjet paper or plastic-coated media should not be used.					
² Only occasional use of paper labels in an office environment is supported.					
³ Only PN 12A5940 and 12A5941 should be used.					
There is no automatic paper type sensing. These settings should be manually set in the operator panel.					

Media sizes

Media sizes	Dimensions		Input			Output
			Universal 250-sheet tray ¹ Standard setting	Universal 250 sheet tray Set to legal	Optional 530-sheet tray ²	Standard 250-sheet bin
	mm	in				
A4	210 x 297	8.27 x 11.7	X	X	X	X
A5	148 x 210	5.83 x 8.27	X			X
JIS B5 ³	182 x 257	7.17 x 10.1	X	X		X
Letter	216 x 279.4	8.5 x 11	X	X	X	X
Legal	216 x 356	8.5 x 14		X		X
Executive	184.2 x 266.7	7.25 x 10.5	X	X	X	X
Folio	216 x 330	8.5 x 13	X			X
Statement	139.7 x 215.9	5.5 x 8.5	X			X
Universal ¹			X	X		X
Standard 250-sheet letter tray	104.8 x 210 to 215.9 x 297	4.125 x 8.27 to 8.5 x 11.7				
Optional 250-sheet legal tray	104.8 x 210 to 215.9 x 355.6	4.125 x 8.27 to 8.5 x 14				
Envelope sizes	Dimensions	Dimensions				
9 Envelope ²	98.4 x 225.4	3.875 x 8.9	X	X		X
COM 10 Envelope	104.8 x 241.3	4.12 x 9.5	X	X		X
DL Envelope	110 x 220	4.33 x 8.66	X	X		X
C5 Envelope ²	162 x 229	6.38 x 9.01	X	X		X
B5 Envelope ²	176 x 250	6.93 x 9.84	X	X		X
¹ Select Universal when using a non-standard size sheet of print material. The MFP formats the page for the maximum size 8.5 X 14 in(215.9 X 355.6 mm). Set the actual size from your software application.						
² Supported through the driver.						
³ B5 may be supported in optional tray 1, but size sensing must be turned off.						

Output capacity by media and source

Source	Media	Capacity	Orientation
Standard output bin (top) ¹	Supports all sizes listed in the "Media sizes" table	250 sheets (20 lb paper) 50 Transparencies	Collated Facedown

Scan specifications

Resolution	1200 X 2400 dpi
Scan size	216mm X 297 mm (flatbed), Window size 220mm X 300mm
Scan depth	48 bits
Lamp warm up time	Less than 3 seconds
MTF	More than 30%
Depth of focus	-2 mm to +2 mm
Magnification	Less than 0.5%
Scanning	TWAIN
Connectivity	USB 2.0, and Ethernet (10/100 Base TX-TCP/IP only)
Push scan	Scan to E-mail, scan to FTP, scan to host PC
Web status monitor	Yes
Scanner driver (TWAIN) features	
Scan mode	True color, grayscale, black & white
Contrast adjustment	Yes
Brightness adjustment	Yes
Color / Mono switch	Yes
Scan to E-mail feature	
Network requirements	TCP/IP and an SMTP gateway
Authorization function	SMTP authentication, POP3 before SMTP
Register E-mail address	By Web page
Scan destination	Set up in scan profile
E-mail address maintenance	By Web page
Job Search	By profile name
Subject input	20 characters maximum. Entered by the Web page interface
Maximum E-mail data size	
Supported file formats	TIFF, JPEG, PDF

Copy specifications

Resolution	600 dpi X 600 dpi (flatbed), 600 X 300 dpi(ADF), Print from copy —600 X 600 dpi 9600 dpi X 9600dpi w/ software interpolation
Original paper sizes	A4, Letter, Legal (ADF only), B5 (JIS), Executive
Copies per minute	Mono: up to 21, Color: up to 7 ¹
Time to first copy	Less than 30 seconds ²
Multiple copies	99 copies maximum
Output paper sizes	A4, Letter, Legal (optional cassette only)
Image density adjustment	5 levels, manual only
Image quality modes	Text, Photo, and Mixed
Zoom	25% to 400% in increments of 1%
Present reduction ratio	US: 25%, 65%, 78%, 93% EU: 25%, 71%, 86%, 93%
Present enlargement ratio	US: 129%, 155%, 200%, 400% EU: 122%, 141%, 200%, 400%
Advanced copier features	
Combine multiple copies into one copy.	2 into 1, 4 into 1. Can be toggled between landscape and portrait.
Electronic sort	Yes
Scan once print many	Yes
Limitless paper feed	Yes
Memory copy	Standard
Copy counter indicator	Standard
Jam recover auto restart	For print jams only.
Buzzer to finish job	Yes
ADF	
ADF width	5.5 to 8.5 inches (139.7 to 215.9 mm)
ADF length	5.5 to 14 inches (139.7 to 355.6 mm)
ADF capacity	35 sheets
1 - assumes 50% coverage 2 - Does not include scanner and printer warm-up time.	

Fax specifications

Phone network connectivity

Phone networks types supported	Both PSTN and PABX are supported.
Compatibility	T30(ITU-T Super G3) is supported. Color fax is not supported.
Modem speed	Automatic fallback: 33600 bps V34, V17, V29, and V27ter are supported for image transmission. V8, and V21 are supported for control channels.
Compression	MH, MR, MMR, and JBIG

Document Sizes supported

ADF width	5.5 to 8.5 inches (139.7 to 215.9 mm)
ADF length	5.5 to 14 inches (139.7 to 355.6 mm)
ADF capacity	35 sheets
Flatbed width	8.5 inches (216 mm)
Flatbed length	11.7 inches (297 mm)
Scanning width	215.9 mm maximum
Printing width	Legal – 215.9 mm X 355.6 mm Letter – 215.9 mm X 279.4 mm A4 - 210.0 X 297.0 mm

Fax scan resolutions

Horizontal		
Fixation	200 dpi	8 dot/mm
Vertical		
Standard	100 dpi	3.85 dot/mm
Fine	200 dpi	7.7 dot/mm
Photo	200 dpi	7.7 dot/mm

Miscellaneous FAX specifications

Halftone/error diffusion	Error diffusion
Speed dial	50 entries (name 20 characters, number 40 digits)
Quick dial	20 entries (name 20 characters, number 40 digits)
On hook dial	Yes
Direct Fax number entry	Yes
Re dial	Yes
Transmission	
Immediate transmission	Yes
Memory transmission	Yes
Page retransmission	Yes
Error correction mode	Yes
Broadcasting	Yes (100 entries)
Reception	
FAX only mode	Yes
Manual mode	Yes
Auto reduction	Yes (Threshold 74%)
Error correction mode	Yes
Reports	
Activity report	Yes
Transmission verification report	Yes
Power failure report	Yes
Phone book list	Yes
Quick dial list	Yes
Speed dial list	Yes
Memory manage list	Yes
User parameter list	Yes
Clear memory transmission file	
Memory job clear	Standard
All clear	Standard

Media guidelines

Paper designed for use with xerographic copiers should provide satisfactory print quality and feed reliability. Other media types may be suitable. We recommend that users test any particular brand for suitability to their applications. Refer to the MFP User's Guide for additional media specifications.

Paper

- Rough, highly textured, limp, or pre-curved papers will result in lower print quality and more frequent paper feed failures.
- Colored papers must be able to withstand 338°F (170°C) fusing temperature.
- Preprinted forms and letterheads should be selected using guidelines in the MFP User's Reference. The chemical process used in preprinting may render some papers unsuitable for use with the MFP.
- Unsuitable papers include punched, embossed, water-marked, perforated media, any kind of inkjet paper or plastic-coated paper.
- Recycled paper less than 75 g/m² (20 lb) may cause unacceptable results.

The laser printing process heats paper to high temperatures of 170°C (338°F). Use only paper able to withstand these temperatures without discoloring, bleeding, or releasing hazardous emissions. Check with the manufacturer or vendor to determine whether the paper you have chosen is acceptable for laser printers.

Envelopes

Should be fed with short edge first, flap down and to the right.

- If envelope wrinkling occurs, refer to the User's Reference for correct loading and stacking of envelopes.
- All envelopes should be new, unused, and without damage.
- Envelopes with excessive curl or twist exceeding 6.0 mm, those stuck together, those with bent corners or nicked edges, or those that interlock should not be used.
- Minimum weight: 90 g/m² (24 lb).
- The following envelopes should not be used:
 - Envelopes with windows, holes, perforations, cutouts, or deep embossing
 - Envelopes with metal clasps, string ties, or metal folding bars
 - Envelopes with exposed flap adhesive when the flap is in the closed position
 - Self-seal envelopes
- Under high-humidity conditions (over 60%), the envelopes may seal during printing.
- For best results, print on new 90 g/m² (24 lb) sulfite or 25% cotton-bond envelope.

Transparencies

- Use letter (12A5940) or A4-size (12A5941) sheets only.
- Transparencies are only supported in tray 1 (standard or legal trays).

Labels

- Labels should be selected using guidelines found in the User's Guide, Complete Printer Guide, or the Card stock & Label Guide (located at www.lexmark.com), and tested for acceptability.
- Vinyl labels are not supported.
- Labels are only supported in tray 1 (standard or legal trays).

Glossy Paper

- Use letter (12A5950) or A4-size (12A5951) sheets only.
- Glossy paper is only supported from tray 1 (standard or legal trays).

Sensing by source

Input	Paper size	Paper out	Tray present
Integrated 250-sheet	X	X	X
Optional 530-sheet	X	X	X

Maintenance approach

The diagnostic information in this manual leads you to the correct field replaceable unit (FRU) or part. Use the error code charts, symptom index, and service checks to determine the symptom and repair the failure. The removals in the repair information chapter may help you identify parts.

- Printer messages
- Symptom tables
- Service checks
- Repair information

After you complete the repair, perform tests as needed to verify the repair. See **“Diagnostic aids” on page 3-1**.

Standard inspection and cleaning procedure

- Switch off printer power, and disconnect the AC power cord from the electrical outlet.
- Remove and inspect the photodevelopers and toner cartridges, shielding them from strong light.
- Inspect the interior of the printer, removing foreign matter such as paper clips, staples, pieces of paper or transparencies, paper dust, hair, oil, grease, or toner.
- Clean the printer interior using a lint-free cloth. Do not use solvents or chemical cleaners to clean the printer interior.
- Use only the specified oil or lubricant on printer parts (some service parts are lubricated at the factory).
- Inspect and, if necessary, clean all rubber/plastic rolls with a lint-free cloth. Dry the rolls with a lint-free cloth.
- While cleaning, inspect the interior of the printer for damaged wires, loose connections, toner leakage, loose springs, and damaged or worn parts.
- Be sure the printer is on a single, flat, strong table or desk top.
- Inspect all supplies (OCR, cartridges, photodevelopers/toner cartridges, belts, fuser maintenance kits and paper sources (cassettes, trays, feeders, duplex drawers, finisher, mailbox trays) for obvious damage and proper installation (paper guides not too tight). Inspect for correct media usage (paper, transparencies, labels).
- Print demo page.
- If additional paper sources are installed, print a demo page from each of these (if possible).
- Failure to print from an additional tray or feeder may imply one or more pins are bent in the mating connector.

Serial number

Look for serial number information on the right cover and the inside of the front cover of your MFP.

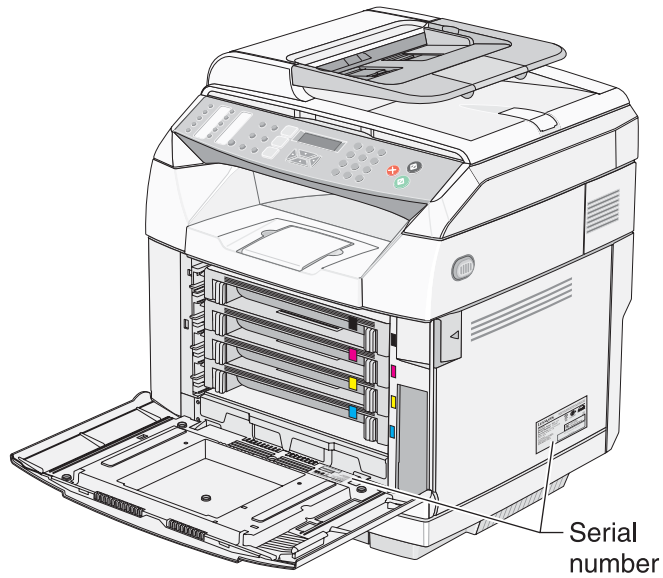

Tools required for service

The removal and adjustment procedures described in this manual require the following tools and equipment:

- Analog volt ohmmeter (A digital volt ohmmeter may also be used.)
- Flat-blade screwdrivers
- Needle-nose pliers
- #1 Phillips screwdriver
- #2 Phillips screwdriver
- Slotted screwdriver #1
- Slotted clock screwdriver #1
- Tweezers, C-ring pliers

When you make voltage readings, always use frame ground unless another ground is specified.

Acronyms

ADF	Automatic document feeder
ASIC	Application specific integrated circuit
BOOTP	Boot protocol
CCD	Charge coupled device
DDNS	Dynamic domain name service
DHCP	Dynamic host configuration protocol
DPI	Dots per inch
DRAM	Dynamic random access memory
EP	Electrophotographic process
ESD	Electrostatic discharge
FRU	Field replaceable unit
HTTP	Hypertext transport protocol
HV	High voltage
HVPS	High voltage power supply
JBIG	Joint Bi-Level Image Experts Group
LAN	Local area network
LASER	Light amplification by simulated emission of radiation
LCD	Liquid crystal display
LED	Light emitting diode
LV	Low voltage
LVPS	Low voltage power supply
MFP	Multiple function printer
NVRAM	Nonvolatile random access memory
MH	Message handling
MMR	Modified modified read
MR	Modem ready
OEM	Original equipment manufacturer
PABX	Private automatic branch exchange
POR	Power-on reset
POST	Power-on self test
PQET	Print quality enhancement technology
PSTN	Public switched telephone network
RIP	Raster image processor
SMTP	Simple mail transport protocol
SDRAM	Synchronous dynamic random access memory
SNMP	Simple network management protocol
TAD	Telephone answering device
TCP/IP	Transmission control protocol Internet protocol
VAC	Volts alternating current
VDC	Volts direct current
WINS	Windows internet name service

7100-XXX

2. Diagnostic information

Start

CAUTION: Remove power from the printer before you connect or disconnect any cable, electronic board or assembly, for personal safety and to prevent damage to the printer. Always use the hand grips on the side of the printer and be sure your fingers are not under the printer when you set the printer down.

Use the service error codes, user status messages, user error messages, symptom tables, service checks, and diagnostic aids, to determine the corrective action necessary to repair a malfunctioning printer.

Service error codes are indicated by a two-character alphanumeric error code. If a service error code displays, go to the **“Service error codes” on page 2-3**.

User status messages provide the user with information on the current status of the printer. “Ready” displays on the first line of the display unless Power Saver is invoked, then Power Saver is displayed. If a user status message displays, go to the **“User attendance messages” on page 2-8**.

User error messages are indicated by a two- or three-digit error code which provides the user with information explaining a problem with a print cartridge, paper jam, option, port, and so on. If a user error message displays, go to the **“User attendance messages” on page 2-8**.

The User Messages section sometimes allows a servicer to isolate printer problems. This section also gives actions to be taken when they do not set or clear.

If you have a failing symptom, go to the **“Symptom tables” on page 2-11**. Locate your symptom, and take the appropriate action.

If a service error code appears while you are working on the printer, go to the **“Service error codes” on page 2-3** and take the appropriate action.

Understanding the operator panel

Using the MFP menus

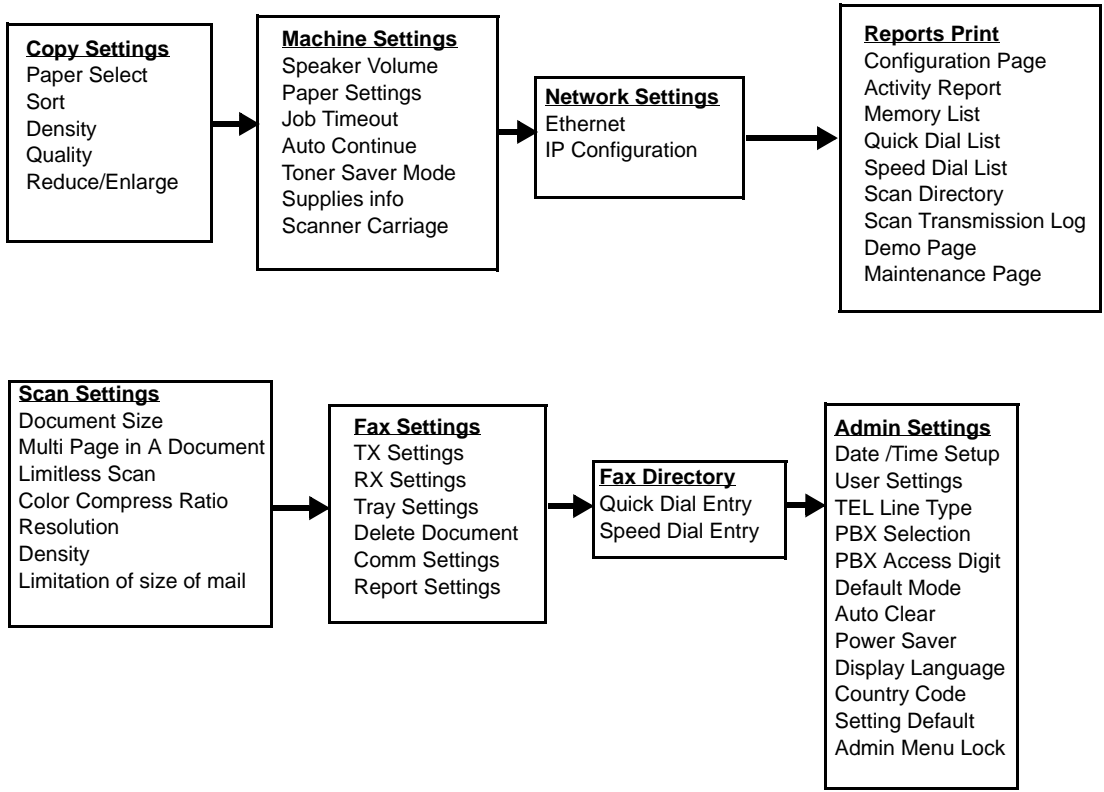

Service error codes

Error code	Action
001 Service Call System Board - CPU	Replace the RIP board. See “System board removal” on page 4-36 . Or replace the engine controller board. See “Engine controller board removal” on page 4-34 .
002 Service Call System Board - Flash	
003 Service Call System Board - DRAM	
004 Service Call System Board - RTC	
009 Service Call System Board	
005 Service Call Op Panel	See “Operator panel service check” on page 2-40 .
006 Service Call Scanner Unit	Scanner unit initialization failed. Home position not found. Possible scanner calibration failure. See “Flatbed service check” on page 2-41 .
007 Service Call Printer Communication Error	Print engine fails to initialize. See “Engine controller board removal” on page 4-34 .
008 Service Call Fax Card	Fax board fails to initialize or fails to respond when a fax is sent. See “Modem / fax card service check” on page 2-43 .
C3 Service Call Engine CTL Board	incorrect data is detected in the NVRAM during data confirmation process at power-on. 1. POR the machine. 2. If problem persists, replace the controller board.
C4 Service Call Engine CTL Board	Defective engine controller board is causing faulty data transmission between ASIC and CPU. POR the printer. If error still exists, replace the engine controller board. See “Engine controller board removal” on page 4-34 .
C7 Service Call Main Motor	Synchronization signal from main motor is not detected. See “Main motor service check” on page 2-14 .
D4 Service Call LV Power Supply	See “Low voltage power supply (LVPS) service check” on page 2-23 .
E0 Service Call Developer Motor 1 - MK	An over-current signal is detected due to an abnormal load on developer motor 1. 1. Replace black and magenta toner cartridge. 2. If error persists, see “Developer drive assembly service check” on page 2-16 .
E1 Service Call Developer Motor 2 - CY	An over-current signal is detected due to an abnormal load on developer motor 2. 1. Replace yellow and cyan toner cartridge. 2. If error persists, see “Developer drive assembly service check” on page 2-16 .

Error code	Action
E2 Service Call Main Motor	A NOT READY signal (rotation error signal) is detected because of abnormal main motor rotation. See “Main motor service check” on page 2-14.
E3 Service Call Transfer Belt Sensor	Unstable transfer belt rotation– color matching cannot be secured. See “Transfer belt unit service check” on page 2-17.
E5 Service Call Transfer Roller Clutch	Improper transfer roller clutch cable connection or a shorted or cut cable. See “Transfer roller clutch service check” on page 2-18.
E6 Service Call Transfer Cleaner Solenoid	Improper cleaning roller clutch cable connection or a shorted or cut cable. See “Transfer belt cleaning roller clutch service check” on page 2-18.
E7 Service Call P feed Clutch Tray 1	Improper paper-feed clutch cable connection or a shorted or cut cable. See “Paper feed clutch service check” on page 2-19.
E8 Service Call Registration Clutch	Improper registration clutch cable connection or a shorted or cut cable. See “Registration clutch service check” on page 2-19.
E9 Service Call OPC Marker Sensor	Marker sensor is not properly detecting mark on OPC belt. See “OPC belt marker sensor service check” on page 2-20.
EL Service Call Erase Lamp	Improper erase lamp cable connection or a shorted or cut cable. Erase lamp LED terminal may be cut. See “Erase lamp service check” on page 2-21.
F0 Service Call Power Supply Fan	Improper fan motor rotation, improper fan motor cable connection or a shorted or cut cable. See “Power supply fan service check” on page 2-22.
F4 Service Call Fuser Fan	Improper fan motor rotation, improper fan motor cable connection or a shorted or cut cable. See “Fuser fan service check” on page 2-22.
F5 Service Call HV Power Supply Unit	Output (BRV) of HVPS is shorted, and or HVPS cable connector is improperly connected. See “High voltage power supply (HVPS) service check” on page 2-23.
F6 Service Call LV Power Supply Unit	Data communication error between LVPS and the engine controller board. See “Low voltage power supply (LVPS) service check” on page 2-23.
H0 Service Call Fuser Unit	Temperature signal from thermistor is not detected. See “Fuser thermistor service check” on page 2-24.
H1 Service Call Fuser Unit	Circuitry that controls the fuser temperature has failed. See “Fuser assembly service check” on page 2-24.
H2 Service Call Fuser Unit	Fusing temperature is not reached within the warming-up time period. See “Fuser assembly service check” on page 2-24.
H3 Service Call Fuser Unit	Fusing temperature drops below fusing threshold during the printing process and does not reach fusing temperature again within allotted time. See “Fuser assembly service check” on page 2-24.

Error code	Action
H4 Service Call Fuser Unit	Fusing temperature rises above limit during printing process and does not return within the allotted time period. See “Fuser assembly service check” on page 2-24.
HA Service Call Fuser Unit	AC relay turned off due to an abnormal temperature. See “Fuser assembly service check” on page 2-24.
L1 Service Call Laser Unit Assembly	Laser scanning beam is not detected by beam sensor. See “Laser unit assembly service check” on page 2-25.
L2 Service Call Laser Unit Assembly	Scanner motor (SM) is rotating abnormally. See “Laser unit assembly service check” on page 2-25.
LL Service Call Laser Unit Assembly	Laser power is lower than the output limit. See “Laser unit assembly service check” on page 2-25.
N3 Service Call HVPS Connection	Improper connection between engine controller board and HVPS. See “HVPS connection service check” on page 2-25.
N4 Service Call Toner Empty Sensor	Improper connection between engine controller board and toner sensor sender board. See “Toner empty sensor (sender-TPD) service check” on page 2-26.
N5 Service Call Toner Empty Rcv	Improper connection between engine controller board and toner sensor receiver board. See “Toner empty sensor (receiver-TTR) service check” on page 2-27.
N6 Service Call LFU Connection	Improper connection between engine controller board and lower paper feed unit. See “Lower feed unit (secondary paper assembly) service check” on page 2-28.
P6 Service Call Pfeed Clutch Tray 2	Data communication error between engine controller board and LFU paper-feed clutch. See “Lower feed unit (secondary paper assembly) service check” on page 2-28.

User status messages

Message	Description	Action
Tray (1, 2) Missing	The upper or lower tray is missing.	install the upper or lower tray. If the problem persists, see “Paper tray missing service check” on page 2-30.
Toner Low (C,M,Y,K)	The toner is low in the cartridge indicated.	See “Toner low/empty service check” on page 2-31.
Sleep	The MFP is idle.	These are the normal operating modes.
Please Wait	The MFP is warming up.	
READY	The MFP is ready to perform a task.	
PC Printing	The MFP is printing.	
Calibrating	The MFP is calibrating.	
Connected to Server	The MFP is connected to a server for a push scan job.	
Sending File...	A scan job is being transmitted.	
Send E-mail Notification	An e-mail is being sent to a user notifying them of a push scan job being completed.	
Connection Fail	Unable to connect to the remote fax.	
No Response	The device	
Busy	The remote fax device is currently busy.	
Dial Failed	The dial attempt to another device failed.	
Scanning Page	The scanner is scanning in the flatbed or ADF.	
Job #	Fax Job # is being processed.	
Dialing	A fax number is being dialed.	
Awaiting Re dial	The fax is between dialing attempts.	
Transmitting	The fax is transmitting data to another fax device.	
Receiving	The X502 is receiving fax data from a remote fax device.	

Message	Description	Action
TAD Answering	A telephone call is being received.	These are the normal operating modes.
Answering	The fax is answering an incoming call.	
incoming Call	There is an incoming call on the phone line	
Warming Up	The MFP is warming up.	

User attendance messages

Message	Description	Action
Paper Empty (Load Tray - Paper Size, Load Tray 1 Paper Size, Load Tray 2 Paper Size, Load Tray Paper)	The upper or lower paper tray is empty or the media in the trays is inconsistent.	Fill up the paper tray(s) or replace the media with the correct type. If the problem persists, see “Tray empty service check” on page 2-29.
Paper Change Load Paper <Type, Size>	Media size and type mismatch.	<ul style="list-style-type: none"> • Check the media size. • Check the media size setting in the cassette. • Check to make sure the media setting on the printer and drive match the media in the cassette.
Paper Error Load Tray 1 <Paper Type>	Media type mismatch.	Load the paper tray with the correct media type.
Tray (1, 2) Missing	The upper or lower tray is missing.	install the upper or lower tray. If the problem persists, see “Paper tray missing service check” on page 2-30.
Toner Low (C,M,Y,K)	The toner is low in the cartridge indicated.	See “Toner low/empty service check” on page 2-31.
C/M/Y/K Toner Empty Replace Toner C/M/Y/K	The specific toner cartridge needs to be replaced. in most cases, only one of the letters CYMK will appear.	install the appropriate toner cartridge. If problem persists, see “Toner low/empty service check” on page 2-31.
Waste Pack Full	The waste toner bottle is full or not installed.	install the waste toner bottle or replace the full waste toner bottle. If problem persists, see “Waste toner bottle service check” on page 2-31.
OPC Exhausted Replace OPC Belt	Replace with a new OPC unit.	See “Photodeveloper cartridge removal” on page 4-8.
OPC Belt Life Replace OPC Belt	Replace with a new OPC unit.	See “Photodeveloper cartridge removal” on page 4-8.
Fuser Life Replace Fuser	Replace with a new fuser unit.	See “Fuser assembly removal” on page 4-6.
TR Belt Life Replace Transfer Belt	Replace with a new transfer belt unit.	See “Transfer belt unit removal” on page 4-5.
Missing install Fuser Unit	The fuser is not installed.	If fuser is installed, remove it and reinstall. If problem persists, check the cable that connects engine controller board connector FUCN and fuser. If the cable is bad, replace the cable. Otherwise, replace the engine controller board. See “Engine controller board removal” on page 4-34.

Message	Description	Action
Toner Error install Supported Cartridge	An invalid toner cartridge is installed.	install a supported cartridge. If the problem persists, see “Missing toner cartridge service check” on page 2-32.
Missing install Toner (C,M,Y,K)	A toner cartridge is not keyed properly.	install proper brand of toner cartridge. If problem persists, see “Missing toner cartridge service check” on page 2-32.
Missing install OPC Belt	The OPC belt cartridge is not installed.	Correctly install the photodeveloper cartridge to clear message and continue printing. If error persists, see “Missing photodeveloper cartridge service check” on page 2-33.
Missing install Transfer Roller	The transfer roller is not installed.	Ensure transfer roller is properly installed. If problem persists, see “Transfer roller missing service check” on page 2-34.
Paper Jam A 1-2	Paper is jamming at feeding area.	See “Paper Jam A1, rear (tray 1)” on page 3-24 or “Paper Jam A2, rear (tray 2)” on page 3-26 for instructions to clear the jam.
Paper Jam B	Paper is jamming inside the MFP.	See “Paper Jam B rear” on page 3-27 for instructions to clear the jam.
Paper Jam C	Paper is jamming at paper exit area.	See “Paper Jam C rear” on page 3-29 for instructions to clear the jam.
Cover Open Close (Front, Rear, OPC)	The back, front, or OPC cover is open.	Close specified cover if open. If not open, open the cover and close. If the problem persists, see “Cover open service check” on page 2-35.
TR Belt Life Replace Transfer Belt	The transfer belt is at its end of life.	Replace the transfer belt. See “Transfer belt unit removal” on page 4-5.
TR Kit Life Replace PQ Kit	The transfer roll and transfer belt cleaning roll have reached the end of life.	Replace the transfer roll. See “Transfer roller removal” on page 4-6. Also, replace the transfer belt cleaning roller. See “Transfer belt cleaning roller removal” on page 4-4.
PF1 Kit Life Replace PF Kit 1	The paperfeed roll and separator pad in tray 1 are at the end of life.	Replace the paperfeed roll and the separator pad for the respective paper tray (1 or 2). See “Paper feed roller removal” on page 4-32.
PF2 Kit Life Replace PF Kit 2	The paperfeed roll and separator pad in tray 2 are at the end of life.	
ADF Jam Open ADF cover and Clear Jam	A sheet of paper is jammed in the ADF.	Clear the ADF jam. If the message persists, see “ADF streak service check” on page 2-41.
ADF Cover Open Close ADF cover	The ADF cover is open.	Close the ADF cover. If the cover is already closed, see “ADF streak service check” on page 2-41.
Scan Calibration Error	Scanner is out of calibration.	Perform scanner calibration.
Scan Lock Error Unlock Scanner	The scanner lock is in the locked position.	Unlock the scanner. If the scanner lock is in the unlocked position, see “Flatbed service check” on page 2-41.

Message	Description	Action
Scan USB Disconnect	The USB connection is disconnected.	See “USB service check” on page 2-40.
Scan Network Disconnect	The network connection is disconnected.	See “Network service check” on page 2-40.
Duplicate IP Address Found	Another device using an identical IP address has been detected on the network.	Contact the network administrator.
E-mail Size Limit Exceeded	E-mail memory buffer full.	Retry the job. Break it up if needed.
Out of Memory	Memory depleted.	Retry the print job. Break it up if needed.
Scan Memory Full	Memory for the scan job is full.	Break the scan job into smaller segments.
Communication Error	Communication with host machine failed.	Retry the job. Check all connections with the host device.
Server Connection Failed	Communications with the server failed.	Retry the job. Check all connections with the host device.
(TX / RX) Comm Error	There is a data transmission or reception error.	Resend the fax.
CPU fan locked	The CPU fan is no longer running on the RIP card.	See “CPU fan service check” on page 2-16.

Note: The expected yield of the separator pad and paperfeed roll are 120,000 pages.

Symptom tables

MFP symptom table

Symptom	Action
Paper feed problems	See “Paper feed service checks” on page 2-44.
Close door displayed when all doors are closed.	See “User attendance messages” on page 2-8, and follow the action suggested.
Paper jam messages do not reset after removing paper.	See “User attendance messages” on page 2-8, and follow the action suggested.
Toner cartridge does not turn or does not put toner on the photodeveloper cartridge.	See “Toner feed service check” on page 2-39.
Developer motor makes noise or continuously runs.	See “Developer drive assembly service check” on page 2-16.
Main motor makes noise or continuously runs.	See “Main motor service check” on page 2-14.
Transfer belt unit makes noise when rotated or does not rotate at all.	See “Transfer belt unit service check” on page 2-17.
The transfer roll is not transferring images or does not turn.	See “White band service check” on page 2-63.
No power	See “Printer no power service check” on page 2-38.
Waste toner feed problems	See “Waste toner feed service check” on page 2-39.
Fans not working or making noise.	See “Service error codes” on page 2-3. Find the failing fan, and follow the action suggested.
Print/image problems	See “Print quality symptom table” on page 2-13.
Photodeveloper cartridge does not rotate or makes noise.	See “OPC belt (photodeveloper) cartridge drive service check” on page 2-36.
Black copies from scanner.	See “Black page copy service check” on page 2-41.
Fail to scan from the flatbed.	See “Flatbed service check” on page 2-41.
Paper jams in the ADF.	See “ADF paper feed service check” on page 2-42.
Paper skews when fed into the ADF.	See “ADF paper feed service check” on page 2-42.
Paper fails to feed into the ADF.	See “ADF paper feed service check” on page 2-42.
Op panel failure	See “Operator panel service check” on page 2-40.
Fax fails to transmit.	See “Modem / fax card service check” on page 2-43.
Fax appears stretched or compressed.	Issue with sending fax machine.
Streaks down the middle of a copy, fax or scan when using the ADF	See “ADF streak service check” on page 2-41.
Scanner locked	Check the scanner lock switch. If it is unlocked see “Flatbed service check” on page 2-41.
Scanner fails to communicate with the host PC.	If the MFP is USB-attached, see “USB service check” on page 2-40. If the MFP is network-attached, see “Network service check” on page 2-40.

Symptom	Action
No dial tone when sending a fax.	See “Modem / fax card service check” on page 2-43.
Lines on outbound fax documents	Check the flatbed glass for scratches or marks.
Words and images on inbound fax documents are stretched out.	The sending machine had a temporary jam.

Print quality symptom table

Symptom	Action
Background	See “Background service check” on page 2-45.
Missing image at edge	See “Missing image at edge service check” on page 2-53.
Jitter	See “Jitter service check” on page 2-52.
Ribbing	See “Ribbing service check” on page 2-57.
Wrinkle and image migration	See “Wrinkle / image migration service check” on page 2-67.
White line	See “White line II service check” on page 2-64.
White line	See “White line II service check” on page 2-64.
Vertical white band	See “Vertical white band service check” on page 2-62.
Black line	See “Black line service check” on page 2-48.
Vertical line	See “Vertical line service check” on page 2-60.
Vertical staggering image	See “Vertical staggering image service check” on page 2-61.
Banding	See “Banding service check” on page 2-47.
White band	See “White band service check” on page 2-63.
Toner drop	See “Toner drop service check” on page 2-59.
White spots and black spots	See “White spot / black spot service check” on page 2-65.
Mixed color image	See “Mixed color image service check” on page 2-54.
Color misregistration	See “Color misregistration service check” on page 2-49.
Mottle	See “Mottle service check” on page 2-55.
Residual image	See “Residual image service check” on page 2-56.
Insufficient gloss	See “insufficient gloss service check” on page 2-51.
Back stain	See “Back stain service check” on page 2-46.
White print	See “White print service check” on page 2-66.
Insufficient fusing	See “insufficient fusing service check” on page 2-50.

Printer service checks

Main motor service check

Step	Questions / actions	Yes	No
1	Turn printer off and remove right cover. See “Right cover removal” on page 4-13. Open top cover and override top cover interlock switch. Restart printer, and observe main motor and photodeveloper cartridge OPC belt. Does main motor attempt to turn but OPC belt will not rotate?	Replace photodeveloper cartridge. Note: photodeveloper cartridge is a customer-ordered supply.	Go to step 2.
2	Observe main motor and fuser. Does main motor attempt to turn but fuser will not?	Replace fuser assembly. See “Fuser assembly removal” on page 4-6. Note: Fuser is a customer-ordered supply.	Go to step 3.
3	Are there any unusual noises around main motor before error posts?	Replace main motor. See “Main motor assembly removal” on page 4-26. Go to step 4.	Go to step 5.
4	Does noise go away?	Problem solved.	Go to step 5.
5	Is cable properly connected to main motor?	Go to step 6.	Properly connect cable. Retest printer. If error clears, problem solved, otherwise go to step 6.
6	If waste toner bottle is removed, reinsert it. Ensure rear cover assembly cover is shut. Override top and front cover interlock switches. For location, see “Fan/motor and interlock switch locations” on page 5-6. Reconnect operator panel. Turn printer on. Allow printer to run until error posts. Disconnect connector from main motor, and check the following on disconnected cable connector: Pin 4 to pin 5– 24VDC Pin 6 to pin 5– 24VDC Pin 10 to pin 5– 5VDC Are voltages present?	Replace main motor. See “Main motor assembly removal” on page 4-26. Go to step 9.	Go to step 7.
7	Remove engine controller board shield. See “Engine controller board removal” on page 4-34 for steps to remove engine controller board shield. Disconnect MCN5 from engine controller board. Check for continuity and shorted pins on cable that connects MCN5 to main motor. Is cable okay?	Go to step 8.	Replace cable. Retest printer. If error clears, problem solved, otherwise go to step 8.

Step	Questions / actions	Yes	No
8	Disconnect cable from engine controller board POCN. Check the following on disconnected cable connector: Pin 21 to pin 22– 24VDC Pin 13 to pin 14– 5VDC Are voltages present?	Replace engine controller board. See “Engine controller board removal” on page 4-34 . Go step 9.	Replace cable that connects ACN1 on LVPS to POCN on engine controller board. Remove RIP board cage to gain access to cable. See “System board cage removal” on page 4-39 . Go to step 9.
9	Reassemble and retest printer. Does error clear?	Problem solved.	Contact next level of support.

CPU fan service check

Step	Questions / actions	Yes	No
1	Open the RIP cage cover. Is the CPU fan spinning?	No issue to fix.	Go to step 2.
2	Is the CPU fan cable properly connected to J-Fan1 on the RIP board?	Connect the cable to J-Fan1.	Replace the RIP board. See “System board removal” on page 4-36.

Developer drive assembly service check

Step	Questions / actions	Yes	No
1	Are there any unusual noises heard around developer motor or developer drive assembly before error posts?	Replace toner cartridge (customer-ordered supply). Go to step 2.	Go to step 4.
2	Does noise go away?	Problem solved.	Replace developer drive assembly. See “Developer drive assembly removal” on page 4-22. Go to step 3.
3	Does noise go away?	Problem solved.	Go to step 4.
4	Turn printer off, and remove right cover. See “Right cover removal” on page 4-14. Is cable properly connected to developer drive assembly motor?	Go to step 5.	Properly connect cable. Retest printer. If error clears, problem solved, otherwise go to step 5.
5	If waste toner bottle is removed, reinsert it. Ensure rear cover assembly is shut. Override top and front cover interlock switches. For location, see “Interlock switch locations” on page 5-6. Reconnect operator panel. Turn printer on. Allow printer to run until error posts. Disconnect connector from each developer motor, and check for the following on each disconnected cable connector: Pin 2 to ground– 24VDC Pin 5 to ground– 24VDC Are voltages present?	Replace developer drive assembly. See “Developer drive assembly removal” on page 4-21. Go to step 8.	Go to step 6.
6	Remove engine controller board shield. See “Engine controller board removal” on page 4-34 for steps to remove engine controller board shield. Disconnect MCN5 from engine controller board. Check for continuity and shorted pins on cable that connects MCN5 to developer motors. Is cable okay?	Go to step 7.	Replace cable. Retest printer. If error clears, problem solved, otherwise go to step 7.

Step	Questions / actions	Yes	No
7	<p>Disconnect cable from engine controller board POCN. Check the following on disconnected cable connector:</p> <p>Pin 21 to pin 22– 24VDC Pin 13 to pin 14– 5VDC</p> <p>Are voltages present?</p>	Replace engine controller board. See “Engine controller board removal” on page 4-34 . Go to step 8.	Replace cable that connects ACN1 on LVPS to POCN on engine controller board. Remove RIP board cage to gain access to cable. See “System board cage removal” on page 4-39 . Go to step 8.
8	Reassemble and retest printer. Does error clear?	Problem solved.	Contact next level of support.

Transfer belt unit service check

Step	Questions / actions	Yes	No
1	Open rear cover assembly, and check transfer belt unit markers for stains. Are markers stained?	Clean belt marker area with cotton cloth. If problem persists, go to step 2.	Go to step 2.
2	Remove transfer belt unit, and observe markers on side. Are belt markers deformed or does transfer belt seem hard to rotate?	Replace transfer belt unit. See “Transfer belt unit removal” on page 4-5 .	Reinstall transfer belt unit. Go to step 3.
3	Turn printer off, and remove engine controller board shield. See “Engine controller board removal” on page 4-34 for steps to remove engine controller board shield. Are cables properly connected to engine controller board connectors MCN9 and POCN?	Go to step 4.	Properly connect cables. If problem persists, go to step 4.
4	Ensure rear cover assembly and front cover assembly are closed. Override top interlock switch, and turn printer on. Wait until printer displays error, and remove MCN9 from engine controller board. Check for 5 VDC between MCN9 pin 1 (on engine controller board) and ground (you can touch negative lead of voltmeter to metal frame to obtain ground.) Is voltage present and correct?	Engine controller board is providing 5 VDC to marker sensor. Replace transfer belt marker sensor. Marker sensor is part of a bracket assembly. See “Bracket assembly removal” on page 4-30 . If problem persists, replace engine controller board. See “Engine controller board removal” on page 4-34 .	Go to step 5.
5	On engine controller board, reconnect MCN9 and disconnect cable from POCN. On cable disconnected from POCN, check for 5 VDC from pin 13 to ground (you can touch negative lead of voltmeter to metal frame to obtain ground.) Is voltage present and correct?	LVPS is providing 5 VDC to engine controller board. Replace faulty engine controller board. See “Engine controller board removal” on page 4-34 .	Replace LVPS. See “Low voltage power supply (LVPS) with cage removal” on page 4-41 .

Transfer roller clutch service check

Step	Questions / actions	Yes	No
1	Turn printer off and remove printer right cover. See “Right cover removal” on page 4-13 . Is cable properly connected to transfer roller clutch?	Go to step 2.	Properly connect cable. If problem persists, go to step 2.
2	Disconnect transfer roller clutch from cable. Measure resistance between two outer pins on transfer roller clutch. Does resistance measure between 119 and 145 ohms?	Go to step 3.	Replace faulty transfer roller clutch. See “Clutch removal” on page 4-27 .
3	Remove engine controller board shield. See “Engine controller board removal” on page 4-34 for steps to remove engine controller board shield. Disconnect cable from MCN4 on engine controller board. Check cable continuity from MCN4 pins 5 and 6 (cable) to connector that attaches to transfer roller clutch. Ensure that pins are not shorted. Is cable okay?	Replace engine controller board. See “Engine controller board removal” on page 4-34 . If problem persists, replace faulty transfer roller clutch. See “Clutch removal” on page 4-27 .	Replace cable. If problem persists, replace faulty transfer roller clutch. See “Clutch removal” on page 4-27 .

Transfer belt cleaning roller clutch service check

Step	Questions / actions	Yes	No
1	Turn printer off, and remove printer right cover. See “Right cover removal” on page 4-13 . Is cable properly connected to cleaning roller clutch?	Go to step 2.	Properly connect cable. If problem persists, go to step 2.
2	Disconnect transfer belt cleaning roller clutch from cable. Measure resistance between two outer pins on cleaning roller clutch. Does resistance measure between 198 and 242 ohms?	Go to step 3.	Replace faulty cleaning roller clutch. See “Cleaning roller clutch removal” on page 4-25 .
3	Remove engine controller board shield. See “Engine controller board removal” on page 4-34 for steps to remove shield. Disconnect cable from MCN4 on engine controller board. Check cable continuity from MCN4 pins 1 and 2 (cable) to connector that attaches to cleaning roller clutch. Ensure that pins are not shorted. Is cable okay?	Replace engine controller board. See “Engine controller board removal” on page 4-34 . If problem persists, replace faulty cleaning roller clutch. See “Cleaning roller clutch removal” on page 4-25 .	Replace cable. If problem persists, replace faulty cleaning roller clutch. See “Cleaning roller clutch removal” on page 4-25 .

Paper feed clutch service check

Step	Questions / actions	Yes	No
1	Turn printer off, and remove printer right cover. See “Right cover removal” on page 4-13 . Is cable properly connected to paper feed clutch?	Go to step 2.	Properly connect cable. If problem persists, go to step 2.
2	Disconnect paper feed clutch from cable. Measure resistance between two outer pins on paper feed clutch. Does resistance measure between 119 and 145 ohms?	Go to step 3.	Replace faulty paper feed clutch. See “Clutch removal” on page 4-27 .
3	Remove engine controller board shield. See “Engine controller board removal” on page 4-34 for steps to remove engine controller board shield. Disconnect cable from MCN4 on engine controller board. Check cable continuity from MCN4 pins 9 and 10 (cable) to outer pins on connector that attaches to paper feed clutch. Ensure that pins are not shorted. Is cable okay?	Replace engine controller board. See “Engine controller board removal” on page 4-34 . If problem persists, replace faulty paper feed clutch. See “Clutch removal” on page 4-27 .	Replace cable. If problem persists, replace faulty paper feed clutch. See “Clutch removal” on page 4-27 .

Registration clutch service check

Step	Questions / actions	Yes	No
1	Turn printer off, and remove printer right cover. See “Right cover removal” on page 4-13 . Is cable properly connected to registration clutch?	Go to step 2.	Properly connect cable. If problem persists, go to step 2.
2	Disconnect registration clutch from cable. Measure resistance between two outer pins on paper feed clutch. Does resistance measure between (****check these values) 119 and 145 ohms?	Go to step 3.	Replace registration clutch. See “Clutch removal” on page 4-27 .
3	Remove engine controller board shield. See “Engine controller board removal” on page 4-34 for steps to remove engine controller board shield. Disconnect cable from MCN4 on engine controller board. Check cable continuity from MCN4 pins 7 and 8 (cable) to outer pins on connector that attaches to registration clutch. Ensure that pins are not shorted. Is cable okay?	Replace engine controller board. See “Engine controller board removal” on page 4-34 . If problem persists, replace faulty registration clutch. See “Clutch removal” on page 4-27 .	Replace cable. If problem persists, replace faulty registration clutch. See “Clutch removal” on page 4-27 .

OPC belt marker sensor service check

Step	Questions / actions	Yes	No
1	Remove photodeveloper cartridge and check for defects. Does photodeveloper appear okay?	Go to step 2.	Replace photodeveloper cartridge.
2	Observe markers on side. Are belt markers covered with foreign particles?	Clean marker area with cotton cloth. If problem persists, go to step 3.	Go to step 3.
3	Reinstall photodeveloper cartridge. Turn printer off, and remove engine controller board shield. See “Engine controller board removal” on page 4-34 for steps to remove engine controller board shield. Is cables MCN7 properly connected to engine controller board?	Go to step 3.	Properly connect cable. If problem persists, go to step 4.
4	Ensure rear cover assembly and front cover assembly are closed. Override top interlock switch, and turn printer on. Wait until printer displays error, and remove MCN7 from engine controller board. Check for 5 VDC between MCN7 pin 3 (on engine controller board) and ground (you can touch negative lead of voltmeter to metal frame to obtain ground.) Is voltage present and correct?	Engine controller board is providing 5 VDC to OPC sensor. Replace OPC marker sensor. See “Marker sensor assembly removal” on page 4-47 . If problem persists, replace engine controller board. See “Engine controller board removal” on page 4-34 .	Go to step 5.
5	Reconnect MCN7, and disconnect cable from POCN. On disconnected cable, check for 5 VDC on cable pin corresponding to POCN pin 13. You can touch negative lead of voltmeter to metal frame to obtain ground. Is voltage present and correct?	LVPS is providing 5 VDC to engine controller board. Replace engine controller board. See “Engine controller board removal” on page 4-34 .	Go to step 6.
6	Turn printer off. Disconnect cable that connects LVPS ACN1 to engine controller board POCN, and check for continuity, shorted pins, or any other cable damage. Is cable okay?	Replace LVPS. See “Low voltage power supply (LVPS) with cage removal” on page 4-41 .	Replace cable.

Erase lamp service check

Step	Questions / actions	Yes	No
1	Turn printer off, and remove toner cartridges and photodeveloper cartridge. Check erase lamp cable for proper connection. Is erase lamp cable properly connected?	Go to step 2.	Properly connect erase lamp. Retest printer. If error clears, problem solved, otherwise go to step 2.
2	Check erase lamp for any visible damage. Is erase lamp damaged?	Replace erase lamp. See "Erase lamp removal" on page 4-20 . Retest printer. If error clears, problem solved, otherwise remove toner cartridges and photodeveloper cartridge and go to step 3.	Go to step 3.
3	Set multimeter to check diodes. Looking at erase lamp through front cover, touch meter positive lead to left LED connection and meter negative lead to right LED connection. LED should illuminate. Check all LEDs on erase lamp board. Do any LEDs fail to illuminate?	Replace erase lamp. See "Erase lamp removal" on page 4-20 . Retest printer. If error clears, problem solved, otherwise go to step 4.	Go to step 4.
4	Remove engine controller board shield. See "Engine controller board removal" on page 4-34 for steps to remove engine controller board shield. Is cable properly connected to engine controller board connector MCN8?	Go to step 5.	Properly connect cable. Retest printer. If error clears, problem solved, otherwise go to step 5.
5	Disconnect cable from erase lamp and engine controller board MCN8. Check for continuity between cable pin that corresponds to MCN8 pin 11 and erase lamp cable connector pin 3. Also check for continuity between cable pin that corresponds to MCN8 pin 12 and erase lamp cable connector pin 1. Check for shorted pins on both sides of cable. Is cable okay?	Replace engine controller board. See "Engine controller board removal" on page 4-34 . Go to step 6.	Replace cable. Retest printer. Go to step 6.
6	Retest printer. Does error clear?	Problem solved.	Contact higher level support.

Power supply fan service check

Step	Questions / actions	Yes	No
1	Turn printer off, and remove engine controller board shield. See “Engine controller board removal” on page 4-34 for steps to remove engine controller board shield. Is cable properly connected to engine controller board connector MCN10?	Go to step 2.	Properly connect cable.
2	Ensure rear cover assembly cover is shut. Override top and front cover interlock switches. For location, see “Fan/motor and interlock switch locations” on page 5-6 . Turn printer on, and check for 24VDC between engine controller board MCN10 pin 1 and power ground (you can touch negative lead of voltmeter to metal frame to obtain ground.) Is voltage present and correct?	Replace power supply fan assembly. See “Power supply fan removal” on page 4-49 . Retest printer. If error clears, problem solved, otherwise go to step 3.	Go to step 3.
3	Turn printer off, and disconnect cable from engine controller board MCN10 and power supply fan. Check cable for continuity and pin shorts. Is cable okay?	Replace engine controller board. See “Engine controller board removal” on page 4-34 .	Replace cable.

Fuser fan service check

Step	Questions / actions	Yes	No
1	Turn printer off, and remove engine controller board shield. See “Engine controller board removal” on page 4-34 for steps to remove engine controller board shield. Is cable properly connected to engine controller board connector MCN1?	Go to step 2.	Properly connect cable.
2	Ensure rear cover assembly cover is shut. Override top and front cover interlock switches. For location, see “Fan/motor and interlock switch locations” on page 5-6 . Reconnect operator panel. Turn printer on, and check for 24VDC between engine controller board MCN1 pin 4 and power ground (you can touch negative lead of voltmeter to metal frame to obtain ground.) Is voltage present and correct?	Potentially faulty fuser fan. Replace rear cover assembly. See “Rear cover assembly removal” on page 4-14 . Retest printer. If error clears, problem solved, otherwise go to step 3.	Go to step 3.
3	Turn printer off, and disconnect cable from engine controller board MCN1 and power supply fan. Check cable for continuity and pin shorts. Is cable okay?	Replace engine controller board. See “Engine controller board removal” on page 4-34 .	Replace cable.

High voltage power supply (HVPS) service check

Step	Questions / actions	Yes	No
1	Remove photodeveloper cartridge, and ensure charging unit on bottom of photodeveloper cartridge is not damaged. Is charging unit damaged?	Replace photodeveloper cartridge. See “Photodeveloper cartridge removal” on page 4-8. Note: photodeveloper cartridge is a customer-ordered part.	Go to step 2.
2	Check charging unit high voltage contacts in printer. Are they clean?	Go to step 3.	Clean contacts. If problem persists, go to step 3.
3	Replace photodeveloper cartridge. See “Photodeveloper cartridge removal” on page 4-8. Has error cleared? Note: photodeveloper cartridge is a customer-ordered part.	Problem solved.	Go to step 4.
4	Check cable for continuity between engine controller board connector HVCN and HVPS BCN1 connector and for shorted pins. Is cable okay?	Go to step 5.	Replace cable.
5	Replace HVPS. See “High voltage power supply (HVPS) removal” on page 4-40. Has error cleared?	Problem solved.	Go to step 6.
6	Replace engine controller board. See “Engine controller board removal” on page 4-34. Has error cleared?	Problem solved.	Contact higher level support.

Low voltage power supply (LVPS) service check

Step	Questions / actions	Yes	No
1	Check cable for continuity between engine controller board connector LVCN and LVPS ACN4 connector. Also check for shorted pins. Is cable okay?	Go to step 2.	Replace cable.
2	Replace LVPS. See “Low voltage power supply (LVPS) with cage removal” on page 4-41. Does problem persist?	Go to step 3.	Problem solved.
3	Replace engine controller board. See “Engine controller board removal” on page 4-34. Does problem persist?	Contact higher level support.	Problem solved.

Fuser thermistor service check

Step	Questions / actions	Yes	No
1	Remove and reinstall fuser assembly. See “Fuser assembly removal” on page 4-6. Does error clear?	Problem solved.	Go to step 2.
2	Check fuser connector for damage. Replace if necessary. Does error clear?	Problem solved.	Go to step 3.
3	Turn printer off, and check cable that connects engine controller board connector FUCN to fuser for proper connection, continuity, and pin shorts. Is cable okay?	Go to step 4.	Properly connect cable or replace if damaged. If error clears, problem solved, otherwise go to step 4.
4	Replace fuser assembly. See “Fuser assembly removal” on page 4-6. Does error clear? Note: Fuser is a customer order supply.	Problem solved.	Replace engine controller board. See “Engine controller board removal” on page 4-34.

Fuser assembly service check

Step	Questions / actions	Yes	No
1	Check for proper input line voltage. Is line voltage correct?	Go to step 2.	Provide proper line voltage.
2	Remove and reinstall fuser assembly. See “Fuser assembly removal” on page 4-6. Does error clear?	Problem solved.	Go to step 3.
3	Check fuser connector for damage. Replace if necessary. Does error clear?	Problem solved.	Go to step 4.
4	Turn printer off, and check cable that connects engine controller board connector FUCN to fuser for proper connection, continuity, and pin shorts. Is cable okay?	Go to step 5.	Properly connect cable or replace if damaged. If error clears, problem solved, otherwise go to step 5.
5	Replace fuser assembly. See “Fuser assembly removal” on page 4-6. Does error clear? Note: Fuser is a customer-ordered supply.	Problem solved.	Replace LVPS. See “Low voltage power supply (LVPS) with cage removal” on page 4-41. If error does not clear, replace engine controller board. See “Engine controller board removal” on page 4-34.

Laser unit assembly service check

Step	Questions / actions	Yes	No
1	Check LCN connection on laser assembly LDU board. Is connector properly connected?	Go to step 2.	Properly connect LCN cable. If error clears, problem solved, otherwise go to step 2.
2	Check LCN connection on engine controller board. Is cable properly connected?	Go to step 3.	Properly connect LCN cable. If error clears, problem solved, otherwise go to step 3.
3	Check cable that connects engine controller board LCN and LDU LCN connectors for continuity and shorted pins. Is cable okay?	Replace laser unit assembly. “Upper right rear cover removal” on page 4-17. Go to step 4.	Replace cable. Go to step 4.
4	Does error clear?	Problem solved.	Replace engine controller board. See “Engine controller board removal” on page 4-34.

HVPS connection service check

Step	Questions / actions	Yes	No
1	Turn printer off, and remove engine controller board shield. See “Engine controller board removal” on page 4-34 for steps to remove shield. Is cable properly connected to BCN1 on the HVPS and the engine controller board HVCN connector?	Go to step 2.	Properly connect cable. Retest printer. If error clears, problem solved, otherwise go to step 2.
2	Turn printer off, and remove items to expose HVPS. See “High voltage power supply (HVPS) removal” on page 4-40 for steps. Check for continuity and pin shorts of cable that connects engine controller board HVCN and HVPS BCN1. Is cable okay? Also ensure that there is no damage to the connectors on both boards.	Replace HVPS. See “High voltage power supply (HVPS) removal” on page 4-40. Retest printer. If error clears, problem solved, otherwise turn printer off and replace engine controller board. See “Engine controller board removal” on page 4-34.	Replace cable. Retest printer. If error clears, problem solved, otherwise turn printer off and replace engine controller board. See “Engine controller board removal” on page 4-34.

Toner empty sensor (sender-TPD) service check

Step	Questions / actions	Yes	No										
1	Turn printer off. and remove engine controller board shield. See “Engine controller board removal” on page 4-34 for steps to remove engine controller board shield. Is cable properly connected to engine controller board connector MCN8?	Go to step 2.	Properly connect cable. Retest printer. If error clears, problem solved, otherwise go to step 2.										
2	Check the following for continuity between engine controller board MCN8 cable and toner empty sensor (sender-TPD) cable. See “Toner sensor (sender) removal” on page 4-24 for steps to gain access to sensor cable. <table border="0"> <tr> <td><u>MCN8</u></td> <td><u>Toner empty sensor</u></td> </tr> <tr> <td><u>sender</u></td> <td></td> </tr> <tr> <td>pin 1</td> <td>pin 1</td> </tr> <tr> <td>pin 3</td> <td>pin 2</td> </tr> <tr> <td>pin 5</td> <td>pin 3</td> </tr> </table> Also check for shorted pins. Is cable okay?	<u>MCN8</u>	<u>Toner empty sensor</u>	<u>sender</u>		pin 1	pin 1	pin 3	pin 2	pin 5	pin 3	Go to step 3.	Replace cable. Retest printer. If error clears, problem solved, otherwise go to step 3.
<u>MCN8</u>	<u>Toner empty sensor</u>												
<u>sender</u>													
pin 1	pin 1												
pin 3	pin 2												
pin 5	pin 3												
3	Replace toner empty sensor (sender-TPD). See “Toner sensor (sender) removal” on page 4-24 for steps. Retest printer. Does error clear?	Problem solved.	Go to step 4.										
4	Replace engine controller board. See “Engine controller board removal” on page 4-34. POR printer. Does error clear?	Problem solved.	Contact higher level support.										

Toner empty sensor (receiver-TTR) service check

Step	Questions / actions	Yes	No														
1	Turn printer off, and remove engine controller board shield. See “Engine controller board removal” on page 4-34 for steps to remove engine controller board shield. Is cable properly connected to engine controller board connector MCN8?	Go to step 2.	Properly connect cable. Retest printer. If error clears, problem solved, otherwise go to step 2.														
2	Check the following for continuity between engine controller board MCN8 cable and toner empty sensor (receiver-TTR) cable. See “Toner sensor (receiver) removal” on page 4-43 for steps to gain access to sensor cable. <table border="0"> <tr> <td><u>MCN8</u></td> <td><u>Toner empty sensor sender</u></td> </tr> <tr> <td>pin 2</td> <td>pin 1</td> </tr> <tr> <td>pin 4</td> <td>pin 2</td> </tr> <tr> <td>pin 6</td> <td>pin 3</td> </tr> <tr> <td>pin 8</td> <td>pin 4</td> </tr> <tr> <td>pin 9</td> <td>pin 5</td> </tr> <tr> <td>pin 10</td> <td>pin 6</td> </tr> </table> Also check for shorted pins. Is cable okay?	<u>MCN8</u>	<u>Toner empty sensor sender</u>	pin 2	pin 1	pin 4	pin 2	pin 6	pin 3	pin 8	pin 4	pin 9	pin 5	pin 10	pin 6	Go to step 3.	Replace cable. Retest printer. If error clears, problem solved, otherwise go to step 3.
<u>MCN8</u>	<u>Toner empty sensor sender</u>																
pin 2	pin 1																
pin 4	pin 2																
pin 6	pin 3																
pin 8	pin 4																
pin 9	pin 5																
pin 10	pin 6																
3	Replace toner empty sensor (receiver-TTR). See “Toner sensor (receiver) removal” on page 4-43 for steps. Retest printer. Does error clear?	Problem solved.	Go to step 4.														
4	Replace engine controller board. See “Engine controller board removal” on page 4-34 . POR printer. Does error clear?	Problem solved.	Contact higher level support.														

Lower feed unit (secondary paper assembly) service check

Step	Questions / actions	Yes	No
1	Turn printer off, and remove engine controller board shield. See “Engine controller board removal” on page 4-34 for steps to remove shield. Is cable properly connected to engine controller board connector MCN6?	Go to step 2.	Properly connect cable. Retest printer. If error clears, problem solved, otherwise go to step 2.
2	Remove right cover. See “Right cover removal” on page 4-13 . Check cable that connects engine controller board connector MCN6 to lower feed unit for continuity and pin shorts. Is cable okay?	Go to step 3.	Replace cable.
3	Replace lower feed unit. See “Secondary paper feed assembly removal” on page 4-9 . Does error clear?	Problem solved.	Go to step 4.
4	Replace engine controller board. See “Engine controller board removal” on page 4-34 . Does error clear?	Problem solved.	Contact higher level support.

Tray empty service check

Step	Questions / actions	Yes	No
1	Remove paper tray from printer. Press bottom of spring platform latches located in rear corners of paper tray. This releases spring platform of paper tray. Ensure tray is raising paper after insertion. Is tray working properly?	Go to step 2.	Replace paper tray.
2	Ensure paper empty sensor flag swings with ease and is not broken or damaged. Is flag working properly?	Go to step 3.	Replace paper guide (C) assembly. See “Paper guide C assembly removal” on page 4-31.
3	Turn printer off, and remove engine controller board shield. See “Engine controller board removal” on page 4-34 for steps to remove engine controller board shield. Is cable properly connected to engine controller board connector MCN9?	Go to step 4.	Properly connect cable.
4	Reconnect operator panel. Turn printer on. Touch negative lead of voltmeter to metal frame to obtain ground. Touch positive lead to engine controller board MCN9 pin 12 to ensure 5 VDC is being supplied to paper empty sensor. Is 5 VDC present?	Go to step 5.	Go to step 8.
5	insert empty paper tray into printer. Check voltage level on MCN9 pin 14. Is 5 VDC present?	Go to step 6.	Go to step 7.
6	Remove paper tray, fill with paper and reinsert. Check voltage level on MCN9 pin 14. Is 0 VDC present?	Replace engine controller board. See “Engine controller board removal” on page 4-34.	Replace paper guide (C) assembly. See “Paper guide C assembly removal” on page 4-31.
7	Turn printer off. Remove paper guide (C) assembly. See “Paper guide C assembly removal” on page 4-31. Check cable for continuity that connects MCN9 pins 12, 13, and 14 to paper empty sensor. Also check for shorted pins. Is cable okay?	Replace paper guide (C) assembly. See “Paper guide C assembly removal” on page 4-31.	Replace cable.
8	Check cable continuity between LVPS ACN1 and engine controller board connector POCN. Also check for shorted pins. Is cable okay?	Replace LVPS. See “Low voltage power supply (LVPS) with cage removal” on page 4-41.	Replace cable.

Paper tray missing service check

Step	Questions / actions	Yes	No
1	Turn printer off, and remove engine controller board shield. See “Engine controller board removal” on page 4-34 for steps to remove engine controller board shield. Is cable properly connected to engine controller board connector MCN7?	Go to step 2.	Properly connect cable.
2	Turn printer on, and check for 5 VDC between MCN7 pin 2 and ground. Is 5 VDC present?	Go to step 4.	Go to step 3.
3	Check for cable continuity between LVPS ACN1 and engine controller board POCN. Is continuity present?	Replace LVPS. See “Low voltage power supply (LVPS) with cage removal” on page 4-41.	Go to step 4.
4	With paper tray removed, take voltage readings between ground and engine controller board MCN7 pins 4, 6, 8 and 10. Do you read 0 VDC on all the pins?	Replace engine controller board. See “Engine controller board removal” on page 4-34.	Go to step 5.
5	Check cable for continuity between engine board MCN7 and paper size sensor. Also check for shorted pins. Is cable okay?	Replace paper size sensor. See “Left tray guide assembly removal” on page 4-43.	Replace cable by replacing the left tray guide assembly. See “Left tray guide assembly removal” on page 4-43.

Toner low/empty service check

Step	Questions / actions	Yes	No
1	Turn printer off, and remove engine controller board shield. See “Engine controller board removal” on page 4-34 for steps to remove engine controller board shield. Is cable properly connected to engine controller board connector MCN8?	Go to step 2.	Properly connect cable.
2	Reconnect operator panel. Turn printer on. Touch negative lead of voltmeter to metal frame to obtain ground. Touch positive lead to MCN8 pin 2, 4, 6, or 8 for specific color as dictated by list below: MCN8 pin2– black(K) pin4– yellow(Y) pin6– magenta(M) pin8– cyan(C) Slightly remove toner cartridge in question. Voltmeter should read approximately 4.8 VDC. Continue to slowly slide toner cartridge out of printer while noting voltmeter reading. Voltage should slowly decrease until it reads approximately 0 VDC. Is toner sensor system working properly?	Replace engine controller board. See “Engine controller board removal” on page 4-34.	Check cable for continuity between engine controller board connector MCN8 and toner sensor system (both sender and receiver). Also check for shorted pins. See “Toner sensor (sender) removal” on page 4-24 and “Toner sensor (receiver) removal” on page 4-43 for steps to expose cable. If cable is okay, replace toner sensor system.

Waste toner bottle service check

Step	Questions / actions	Yes	No
1	Remove waste toner bottle from printer. Inside waste toner bottle holder, check sensor flag. Does flag work properly, and is it not damaged?	Go to step 2.	Replace waste toner bottle holder. See “Waste toner bottle holder removal” on page 4-22.
2	Reinstall waste toner bottle. Does error clear?	Problem solved.	Go to step 3.
3	Replace waste toner bottle holder. See “Waste toner bottle holder removal” on page 4-22. Does error clear?	Problem solved.	Replace engine controller board. See “Engine controller board removal” on page 4-34.

Missing toner cartridge service check

Step	Questions / actions	Yes	No
1	Remove toner cartridge in question. Holding toner cartridge with developer roller away from you, check toner present sensor actuators located on left rear of toner cartridge. Are actuators damaged?	Replace toner cartridge.	Go to step 2.
2	Insert toner cartridge, and ensure toner present sensor flag moves forward. Remove toner cartridge. Toner present sensor flag should spring forward. Does toner present sensor flag operate correctly?	Go to step 3.	Replace toner present sensor. See “Toner present sensor removal” on page 4-42.
3	Turn printer off, and remove engine controller board shield. See “Engine controller board removal” on page 4-34 for steps to remove engine controller board shield. Is cable properly connected to engine controller board connector MCN2?	Go to step 4.	Properly connect cable.
4	Reconnect operator panel. Turn printer on. Touch negative lead of voltmeter to metal frame to obtain ground. Touch positive lead to engine controller board connector MCN2 pin 2 to ensure 5 VDC is being supplied to toner present sensor. Is 5 VDC present?	Go to step 5.	Go to step 8.
5	Check voltage level on MCN2 pin 1. Is 5 VDC present?	Go to step 6.	Go to step 7.
6	install toner cartridge. Check voltage level on MCN2 pin 1. Is 0 VDC present?	Replace engine controller board. See “Engine controller board removal” on page 4-34.	Replace toner present sensor. See “Toner present sensor removal” on page 4-42.
7	Turn printer off. Check cable for continuity that connects MCN2 pins 1, 2, and 3 to toner present sensor. Also check for shorted pins. Is cable okay?	Replace toner present sensor. See “Toner present sensor removal” on page 4-42.	Replace cable.
8	Touch positive lead to engine controller board connector POCN pins 13, 15, and 17 to ensure 5 VDC is being supplied to engine controller board. Is 5 VDC present?	Replace engine controller board. See “Engine controller board removal” on page 4-34.	Go to step 9.
9	Check cable continuity between LVPS ACN1 and engine controller board connector POCN. Also check for shorted pins. Is cable okay?	Replace LVPS. See “Low voltage power supply (LVPS) with cage removal” on page 4-41.	Replace cable.

Missing photodeveloper cartridge service check

Step	Questions / actions	Yes	No
1	Check photodeveloper cartridge for proper installation. Is cartridge installed properly?	Go to step 2.	install properly.
2	Check printer contacts (A) and photodeveloper cartridge contacts (B) for dirt and damage. Are contacts okay?	Replace photodeveloper cartridge. See “Photodeveloper cartridge removal” on page 4-8. Note: photodeveloper cartridge is a customer-ordered supply. If problem persists, replace HVPS. See “High voltage power supply (HVPS) removal” on page 4-40.	Replace photodeveloper cartridge. See “Photodeveloper cartridge removal” on page 4-8.

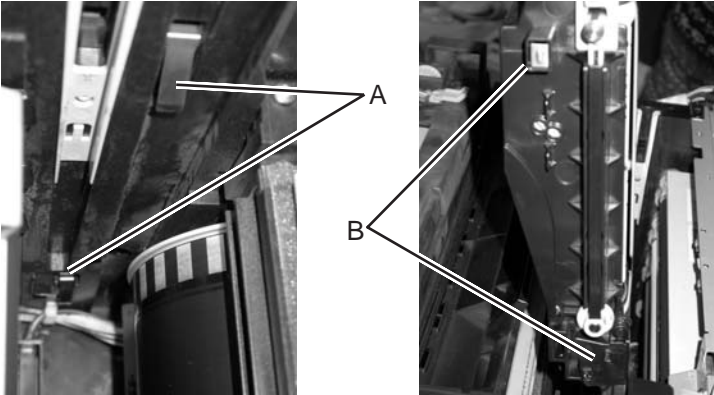

Transfer roller missing service check

Step	Questions / actions	Yes	No
1	Turn printer off, and check transfer roller contacts. Are contacts present and not damaged?	Go to step 2.	If contact A has slipped off frame, put it back on. If you cannot see it, remove HVPS cage (see “HVPS cage removal” on page 4-42) and put it back in place. If B is damaged, replace registration assembly. See “Registration assembly removal” on page 4-33 .
			
2	Replace engine controller board. See “Engine controller board removal” on page 4-34 . Does error clear?	Problem solved.	Replace HVPS. See “High voltage power supply (HVPS) removal” on page 4-40 .

Cover open service check

Step	Questions / actions	Yes	No
1	Turn printer off, and remove right cover. See “Right cover removal” on page 4-13. Check all interlock switch (top, rear and front) actuators for proper operation. Are actuators good?	Go to step 2.	Replace appropriate actuator: Front cover for front cover interlock switch. See “Front cover assembly removal” on page 4-12. Top cover assembly for top cover interlock switch. See “Top cover assembly removal” on page 4-10. Rear cover actuator for rear cover interlock switch. Actuator is contained in parts packet.
2	Check each interlock switch (top, rear and front) for proper operation and damage. Listen for switching action. Using an ohmmeter, check switches. When switch is open (cover open), resistance between pin 1 and pin 3 is 0 and pin 1 and 2 is infinite. Closing switch will show 0 resistance between pins 1 and 2 and infinite resistance between pins 1 and 3. Are switches good?	Go to step 3.	Replace switch in question. See “Front door interlock switch with bracket” on page 4-21 for front interlock switch, see “Power supply fan removal” on page 4-49 for rear and top interlock switches.
3	Turn printer on. Check for 5 VDC between front cover interlock switch pin 1 (top pin) and ground. Is 5 VDC present?	Go to step 5.	Go to step 4.
4	Turn printer off, and check cable for continuity between LVPS ACN2 pin 1 and cable that connects to front cover interlock switch pin 1. Is cable okay?	Replace LVPS. See “Low voltage power supply (LVPS) with cage removal” on page 4-41.	Replace cable.
5	Check the following cables for continuity: <ul style="list-style-type: none"> • Engine controller board MCN4 pin 1 to rear interlock switch pin 3 • Engine controller board MCN4 pin 3 to top interlock switch pin 3 • Top cover interlock switch pin 1 to front cover interlock switch pin 2 • Top cover interlock switch pin 2 to rear cover interlock switch pin 1 • LVPS ACN2 pin 2 to rear cover interlock switch pin 2. Are any cables defective?	Replace cable.	Replace engine controller board. See “Engine controller board removal” on page 4-34.

OPC belt (photodeveloper) cartridge drive service check

Step	Questions / actions	Yes	No
1	Check photodeveloper cartridge for proper installation. Is cartridge installed properly?	Go to step 2.	install properly.
2	Check photodeveloper cartridge for damage. Is cartridge damaged?	Replace photodeveloper cartridge. See “Photodeveloper cartridge removal” on page 4-8. Note: photodeveloper cartridge is a customer-ordered supply.	Go to step 3.
3	Check main motor assembly for damage. Is main motor assembly damaged?	Replace main motor assembly. See “Main motor assembly removal” on page 4-26.	Replace main drive assembly. See “Main drive gear assembly removal” on page 4-27.

Missing fuser service check

Step	Questions / actions	Yes	No
1	Check photodeveloper cartridge for proper installation. Is cartridge installed properly?	Go to step 2.	install properly.
2	Check photodeveloper cartridge for damage. Is cartridge damaged?	Replace photodeveloper cartridge. See “Photodeveloper cartridge removal” on page 4-8. Note: photodeveloper cartridge is a customer-ordered supply.	Go to step 3.
3	Check main motor assembly for damage. Is main motor assembly damaged?	Replace main motor assembly. See “Main motor assembly removal” on page 4-26.	Replace main drive assembly. See “Main drive gear assembly removal” on page 4-27.

Paper size sensing service check

Step	Questions / actions	Yes	No
1	Turn printer off, and remove engine controller board shield. See “Engine controller board removal” on page 4-34 for steps to remove engine controller board shield. Is cable properly connected to engine controller board connector MCN7?	Go to step 2.	Properly connect cable.
2	Turn printer on, and check for 5 VDC between MCN7 pin 2 and ground. Is 5 VDC present?	Go to step 4.	Go to step 3.
3	Check for cable continuity between LVPS ACN1 and engine controller board POCN. Is continuity present?	Replace LVPS. See “Low voltage power supply (LVPS) with cage removal” on page 4-41.	Go to step 4.
4	If paper tray is removed, set paper tray for desired paper size, and insert paper tray into printer. Using table below, check for proper paper size sensor action by taking voltage readings between ground and engine controller board MCN7 pins 4, 6, 8 and 10. Is paper size sensor working properly?	Replace engine controller board. See “Engine controller board removal” on page 4-34.	Go to step 5.
5	Check cable for continuity between engine board MCN7 and paper size sensor. Also check for shorted pins. Is cable okay?	Replace paper size sensor. See “Left tray guide assembly removal” on page 4-43.	Replace cable by replacing the left tray guide assembly. See “Left tray guide assembly removal” on page 4-43.

Paper tray setting	MCN7 (all voltages measured from pin to ground)			
	pin 4	pin 6	pin 8	pin 10
Standard tray				
A4	5 VDC	5 VDC	0 VDC	5 VDC
Letter	5 VDC	0 VDC	5 VDC	5 VDC
EXE	0 VDC	5 VDC	0 VDC	5 VDC
B5J	5 VDC	0 VDC	0 VDC	5 VDC
B51	5 VDC	0 VDC	0 VDC	5 VDC
#10	0 VDC	0 VDC	0 VDC	5 VDC
DL	0 VDC	0 VDC	0 VDC	5 VDC
Legal tray	0 VDC	0 VDC	5 VDC	5 VDC

Printer no power service check

Note: If secondary paper feed assembly or duplex unit is installed, disconnect or remove before checking base printer operation.

Step	Questions / actions	Yes	No
1	Reset printer, and listen for any activation of motors and for power supply fan. Look at operator panel to see if anything displays. Do you hear sounds, or does the operator panel display anything?	Go to step 2.	Go to step 3.
2	Disconnect and check continuity of power cord. Is power cord good?	Go to step 3.	Replace power cord.
3	Ensure RIP board is properly installed. Is RIP board installed correctly?	Go to step 4.	install RIP board.
4	Replace RIP board. See “System board removal” on page 4-36 . Does problem persist?	Replace engine controller board. See “Engine controller board removal” on page 4-34 .	Problem solved.
5	Turn printer off, and check line voltage to ensure that it is present and correct. Is voltage present and correct?	Go to step 6.	inform customer.
6	Remove items (see “System board cage removal” on page 4-39) from left side of printer to expose power supply bracket. Using an ohmmeter, ensure power switch is good. Is power switch good?	Go to step 7.	Replace power supply bracket. See “Low voltage power supply (LVPS) with cage removal” on page 4-41 for steps to remove power supply bracket.
7	Check LVPS ACN1, ACN2, and ACN4 for proper connection. Are cables properly connected to LVPS?	Replace LVPS. See “Low voltage power supply (LVPS) with cage removal” on page 4-41 .	Properly connect cables.

Toner feed service check

Step	Questions / actions	Yes	No
1	Check toner cartridge for damage. Check to see if toner cartridge moves easily into and out of printer. Is toner cartridge damaged or is there resistance moving in and out of printer?	Replace toner cartridge.	Go to step 2.
2	Is developer motor damaged?	Replace developer drive assembly. See “Developer drive assembly removal” on page 4-22.	Go to step 3.
3	Is developer drive assembly damaged?	Replace developer drive assembly. See “Developer drive assembly removal” on page 4-22.	Contact higher level technical support.

Waste toner feed service check

Step	Questions / actions	Yes	No
1	Is transfer belt unit cleaning roller properly installed?	Go to step 2.	Properly install cleaning roller.
2	Check cleaning roller clutch gear (located inside printer) for damage. Is cleaning roller clutch damaged?	Replace cleaning roller clutch.	Go to step 3.
3	Check waste toner bottle for overflow. Is waste toner overflowing?	Go to “Waste toner bottle service check” on page 2-31.	Go to step 4.
4	Check waste toner auger for damage. Is waste toner auger damaged?	Replace waste toner auger. See “Waste toner auger removal” on page 4-48.	Go to step 5.
5	Check waste toner agitator for damage. Is waste toner agitator damaged?	Replace waste toner agitator. See “Waste toner agitator removal” on page 4-48.	Go to step 6.
6	inspect waste toner feeder and opening in bottom of printer. Is waste toner feeder damaged?	Replace waste toner feeder. See “Waste toner feeder removal” on page 4-28.	Problem solved.

Operator panel service check

Step	Questions / actions	Yes	No
1	Is the operator panel cable properly connected to the op panel?	Go to step 2.	Properly connect the cable to the op panel.
2	Is the op panel cable properly connected to the RIP board connector J-PNL1?	Go to step 3.	Properly connect the cable to J-PNL1.
3	Check the op panel cable continuity. Is there continuity?	Go to step 4.	Replace the flatbed unit. See “Flatbed assembly removal” on page 4-50.
4	Check Voltages on J-PNL1, located on the RIP card. Pin 1 voltage should measure 5V. Is it correct?	Replace the operator panel. See “Operator panel removal” on page 4-58.	Replace the system board. See “System board removal” on page 4-36.

USB service check

Step	Questions / actions	Yes	No
1	Is the USB cable properly connected to the MFP and host PC?	Go to step 2.	Properly connect the cable at both ends.
2	Try a different USB cable. Does this fix the issue?	Issue fixed.	Go to step 3.
3	Connect a different device to the USB cable. Did the host PC see the device?	Replace the RIP/system board. See “System board removal” on page 4-36.	There is an issue with the host machine.

Network service check

Step	Questions / actions	Yes	No
1	Ping the MFP using the address on the MFP op panel. Is it responding?	Go to step 3	Go to step 2.
2	Is the ethernet cable properly connected to the network card RJ-45 connector?	Go to step 3.	Properly connect the cable to the RJ-45 jack.
3	Check to see if DHCP is being used on the network. Is DHCP used?	Go to step 4.	Go to step 5.
4	Does the MFP IP address match the ports IP address on the driver?	Go to step 5.	Have the network admin create a port on the host PC matching the IP address on the MFP. Assign the new port to the driver.
5	Have the network admin try a new network cable to the MFP. Did this fix the problem?	Problem resolved.	Replace the system board. See “System board removal” on page 4-36.

Scanner / Copy / Fax service checks

Black page copy service check

Step	Questions / actions	Yes	No
1	Print a menu page, or a page from the host. Is the page black?	See “High voltage power supply (HVPS) service check” on page 2-23	Go to step 2.
2	Is the CCD ribbon cable properly connected to J-CCD on the system board?	Go to step 3.	Properly connect the ribbon cable to J-CCD.
3	Check for +3.3VDC on pins 12 and 16 on connector J-CCD. Pins 10 and 20 are +5VDC. Pin 8 is +12VDC. Are the voltages present?	Replace the flatbed unit. See “Flatbed assembly removal” on page 4-50.	Replace the system board. See “System board removal” on page 4-36.

Flatbed service check

Step	Questions / actions	Yes	No
1	Check to see if the flatbed is locked. Is it locked?	Unlock the flatbed.	Go to step 2.
2	Ensure that the flatbed motor cable (JFB1) is connected. Is the cable connected?	Go to step 3.	Properly connect the cable.
3	Check pin 1 in J-FB1 for voltage. The voltage is only present when a copy job is running. The voltage should measure 5V. Is voltage present?	Replace the flatbed unit. See “Flatbed assembly removal” on page 4-50.	Replace the system board. See “System board removal” on page 4-36.

ADF streak service check

Step	Questions / actions	Yes	No
1	Do streaks appear on the middle of scans when using the ADF?	Clean the ADF glass on the flatbed using a lint-free cloth. Also, clean the separator roll and pad with a damp cloth.	No issue to fix.

ADF paper feed service check

Step	Questions / actions	Yes	No
1	If the ADF is multi-feeding, check for dirt on the ADF separator pad and ADF separator rollers. Are they dirty?	Clean them with a lint free cloth and isopropyl alcohol.	Replace the separator pad and ADF pick roll.
2	If the paper is skewing when it is fed into the ADF, check the paper guide width. Is it set correctly?	Go to step 3.	Set the paper guides so they contact the edges of the paper.
3	If paper is skewing when fed or jamming check to see if the top cover is open or ajar. Is the ADF top cover open or ajar?	Properly close the top cover.	If the paper is jamming in the ADF, go to step 6
4	Is paper failing to feed into the ADF?	Go to step 5.	There is no issue.
5	Check the leading edge of the paper to ensure the paper is not curled or bent in a way that would keep it from contacting the paper sensor actuator. Is the paper damaged?	Bad media.	Go to step 6.
6	Is there dirt in the sensors, or is the paper present actuator stuck?	Clean the sensors, or remove debris from the actuators.	Go to step 7.
7	Are the sensor actuators on the ADF mechanism cover damaged?	Replace the ADF mechanism cover.	Go to step 8.
8	Is the ADF connector properly connected to J-ADF1 on the system board?	Go to step 9.	Properly connect the cable to the system board.
9	inspect the connections on the ADF relay card in the ADF. Are all the connections properly connected?	Go to step 10.	Secure all the connections.
10	Check the ADF cable for continuity. Is there continuity?	Go to step 11.	Replace the ADF cable.
11	Check for signals or voltages from J-ADF. The voltage will only be present on pin 1 when a copy job is run. Pin one on connector J-ADF1 should measure + 5v. Are there signals or voltages present?	Replace the ADF unit. See “ADF unit removal” on page 4-54.	Replace the system board. See “System board removal” on page 4-36.

Modem / fax card service check

Step	Questions / actions	Yes	No
1	Is the phone line properly connected to the modem card and the wall jack?	Go to step 2.	Properly connect the phone line to the modem card and wall jack.
2	Is the modem card cable properly connected to the system board at J-FAX-1 and the modem card?	Go to step 3.	Properly connect the modem card cable to the modem card and system board.
3	Check the modem card cable for continuity. Is there continuity?	Go to step 4.	Replace the modem card cable.
4	Check the voltages from connector J-FAX1 on the RIP card. Check pins 1 and 2 for +3.3V. Pins 24, 27 and 28 are grounds. Are there signals or voltages present?	Replace the modem card. See “Modem card removal” on page 4-46.	Replace the system board. See “System board removal” on page 4-36.

Paper feed service checks

Printer paper feed service check

	Problem area	Action
1	Check for recommended paper	<p>Ensure paper being used is recommended.</p> <p>Ensure paper is stored in an area free from high humidity.</p> <p>Note: Disconnect secondary paper assembly, if installed, to help isolate a paper transport problem.</p>
2	Paper tray	<p>Ensure paper tray is not damaged.</p> <p>Check for paper caught behind tray in pickup transport roll.</p> <p>Replace any damaged parts.</p>
3	<ul style="list-style-type: none"> • Paper feed roller • Separator pad 	<p>Check paper feed roller and separator pad for wear or damage. See “Paper feed roller removal” on page 4-32.</p> <p>Replace any damaged parts.</p>
4	<ul style="list-style-type: none"> • Registration roller • Transfer roller 	<p>Check registration roller for damage or binds, and replace if necessary. See “Registration assembly removal” on page 4-33.</p> <p>Check transfer roller for damage, and replace if necessary. See “Transfer roller removal” on page 4-6.</p>
5	Transfer belt unit	<p>Ensure transfer unit is not damaged and is free of foreign material.</p> <p>Note: Do not touch transfer belt with your hands.</p>
6	Transfer belt unit cleaning roller	<p>Ensure no paper is jammed in cleaning roller.</p> <p>Ensure cleaning roller is not damaged.</p> <p>Replace cleaning roller if necessary.</p>
7	Fuser assembly	<p>Ensure fuser assembly is not damaged or dirty.</p> <p>Ensure fuser assembly guides and gears are not broken and are free of paper.</p> <p>Note: Fuser assembly is a customer-ordered supply.</p>
8	<ul style="list-style-type: none"> • Paper exit assembly • Gears 	<p>Check rear cover assembly for damage.</p> <p>Ensure paper exit roller located in paper exit assembly is not damaged.</p> <p>Ensure paper exit gears and bearings are good.</p> <p>Ensure paper guides are not bent or dirty.</p> <p>Clean or replace parts if necessary.</p>

Print quality service checks

Background service check

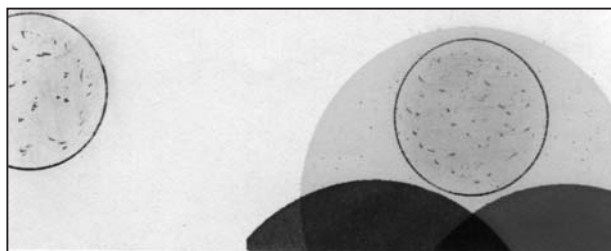

Background is smeared due to toner spread.

	Problem area	Action
1	Toner cartridge	Too small charging amount in the development process.
2	Check developer high voltage contact points.	insufficient contact of developer roller's primary or secondary high voltage contact points. Ensure primary and secondary contact points are free from contamination and toner debris. Check toner cartridge developer roller bias pole. If contaminated, clean it. If damaged or deformed, replace toner cartridge.
3	Photodeveloper (OPC) cartridge	Photodeveloper cartridge has reached life or is failing. Replace photodeveloper cartridge. See “Photodeveloper cartridge removal” on page 4-8. Note: Photodeveloper cartridge is a customer-ordered supply.
4	High voltage power supply (HVPS)	HVPS has failed. Replace HVPS. See “High voltage power supply (HVPS) removal” on page 4-40.

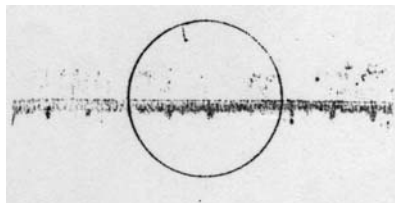
Back stain service check

Backside of paper is stained.

	Problem area	Action
1	Fuser assembly	<ul style="list-style-type: none">• Fuser roller and back-up roller are stained.• Fusing offset error occurred. Replace fuser assembly. See “Fuser assembly removal” on page 4-6. Note: Fuser assembly is a customer-ordered supply.
2	Transfer roller	Transfer roller is stained. Replace transfer roller. See “Transfer roller removal” on page 4-6.

Banding service check

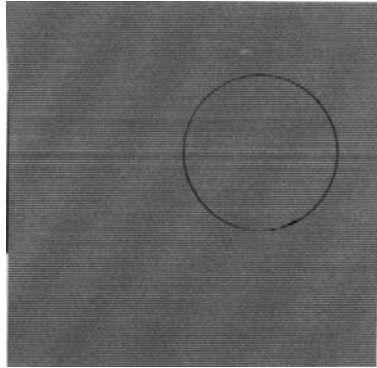

A banding line appears in horizontal direction.

	Problem area	Action
1	Photodeveloper (OPC) cartridge	Transfer failure due to uneven rotational speed caused by a shock which occurs when the seam of the OPC belt passes over the cleaning blade. Replace photodeveloper cartridge. See “Photodeveloper cartridge removal” on page 4-8.
2	Toner cartridge	OPC belt and transfer belt fail to maintain regular and proper rotation due to impact created during retract of toner cartridge. Replace toner cartridge.

Black line service check

A fine black line appears in printer image.

	Problem area	Action
1	Toner cartridge	Toner cartridge blade is deformed. Replace toner cartridge.
2	Photodeveloper (OPC) cartridge	OPC belt surface is damaged. Replace photodeveloper cartridge. See “Photodeveloper cartridge removal” on page 4-8.
3	Debris	Foreign particles (paper dust, and so on) have adhered to perimeter parts of OPC belt and transfer unit belt. Clean perimeter of mounting area of OPC belt and transfer belt.

Color misregistration service check

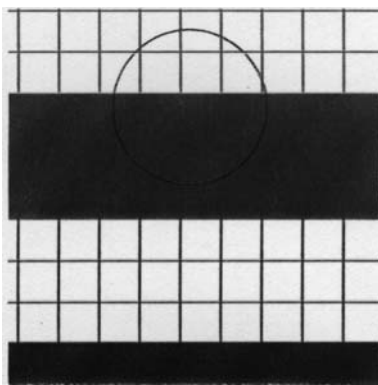

Color misregistration between two colors.

	Problem area	Action
1	Transfer roller and transfer belt cleaning roller	Transfer belt fails to maintain regular and proper rotation due to impact caused when transfer roller or transfer belt cleaning roller contacts transfer belt. Ensure transfer roller and transfer belt cleaning roller are properly installed.
2	Toner cartridge	Developer cartridge OPC belt fails to maintain regular and proper rotation due to impact caused when toner cartridge contacts OPC belt. Ensure toner cartridge is properly installed.
3	Photodeveloper cartridge	OPC belt is off track. Replace photodeveloper cartridge. See “Photodeveloper cartridge removal” on page 4-8. Note: Photodeveloper cartridge is a customer order supply.
4	Transfer belt unit	Transfer belt is off track. Replace transfer belt unit. See “Transfer belt unit removal” on page 4-5.

insufficient fusing service check

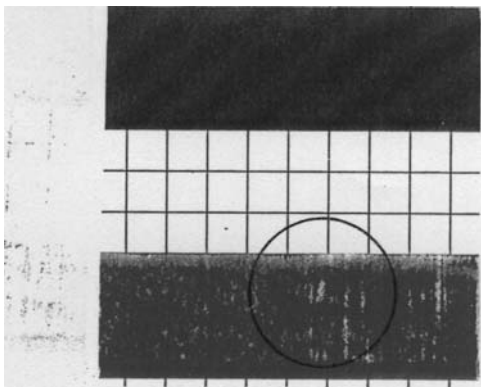

Printed image is partially missing.

	Problem area	Action
1	Fuser tension release lever	Fuser tension release lever is open. Check fuser, and remove shipping pieces if still installed. Close release lever.
2	Driver media settings	Driver media setting is wrong. Ensure proper media setting is selected for specific media in use.
3	Non-recommended paper	Non recommended paper is being used. Replace paper with recommended paper.
4	Fuser	Replace failed fuser. See “Fuser assembly removal” on page 4-6. Note: The fuser is a customer order supply.

insufficient gloss service check

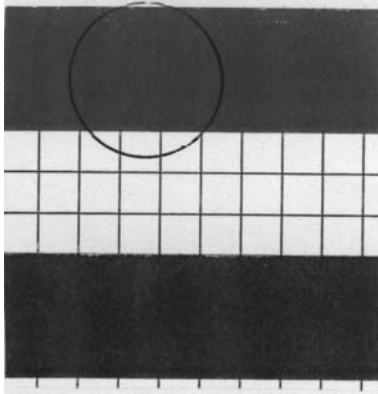

Gloss on paper is not sufficient.

	Problem area	Action
1	Driver media settings	Driver media setting is wrong. Ensure proper media setting is selected for specific media in use.
2	Fuser	Fuser roller is deteriorated. Fuser temperature is not properly controlled. Replace fuser. See “Fuser assembly removal” on page 4-6. Note: The fuser is a customer order supply.

Jitter service check

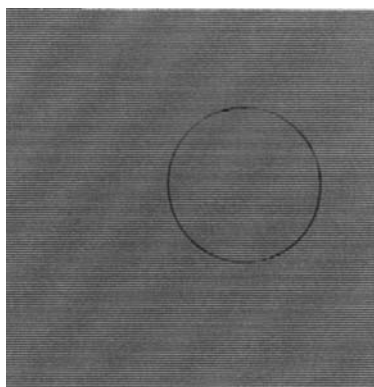

Uneven optical density appears periodically in horizontal direction.

	Problem area	Action
1	Photodeveloper cartridge	Replace faulty photodeveloper cartridge. See “Photodeveloper cartridge removal” on page 4-8. Note: Photodeveloper cartridge is a customer order supply.
2	Main motor assembly	<ul style="list-style-type: none"> • Irregular rotation of main motor assembly • Main motor assembly gear unit failure • Variation of OPC belt running speed due to failing main motor assembly Replace main motor assembly. See “Main motor assembly removal” on page 4-26.
3	Developer drive assembly	Replace faulty developer drive assembly. See “Developer drive assembly removal” on page 4-22.

Missing image at edge service check

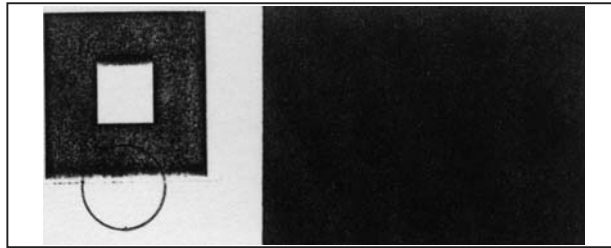
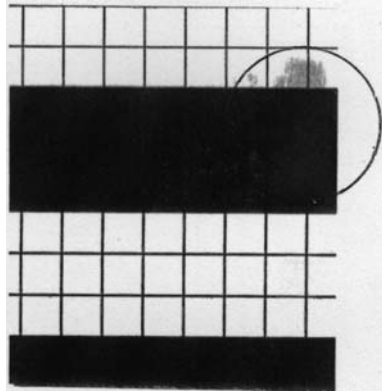

Image has missing or peeling toner at edge.

	Problem area	Action
1	Toner cartridge	Too small a toner mass amount and charging amount in the development process. Replace toner cartridge.
2	Photodeveloper cartridge	OPC belt is deformed and wavy. Replace photodeveloper cartridge. See “Photodeveloper cartridge removal” on page 4-8. Note: Photodeveloper cartridge is a customer order supply.

Mixed color image service check



Mixed color image appears.

	Problem area	Action
1	Toner cartridge	Ensure toner cartridge moves in and out of printer without a lot of resistance. Compare toner cartridge in question with one of the other known working cartridges. Replace toner cartridge if defective.
2	Transfer roller clutch	Replace transfer roller clutch. See “Clutch removal” on page 4-27.
3	Transfer belt unit cleaning roller clutch	Replace transfer belt unit cleaning roller clutch. See “Cleaning roller clutch removal” on page 4-25.

Mottle service check

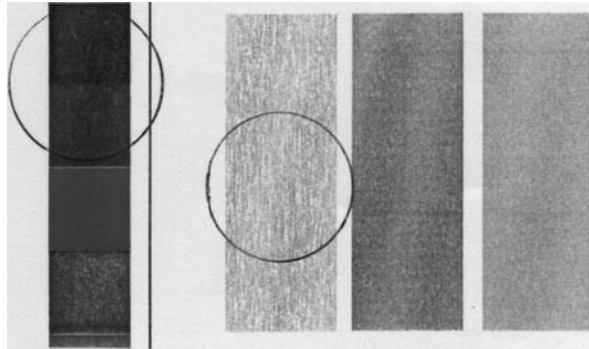

Variation of optical density is found in image.

	Problem area	Action
1	Rear cover assembly	Rear cover assembly is not fixed in place. Open rear cover assembly, and close properly.
2	Transfer roller	Transfer roller is not properly installed. Remove and reinstall transfer roller. See “Transfer roller removal” on page 4-6.
3	Paper	Replace deformed paper.
4	Toner cartridge	Replace defective toner cartridge.
5	HVPS	Replace faulty HVPS. See “High voltage power supply (HVPS) removal” on page 4-40.

Residual image service check

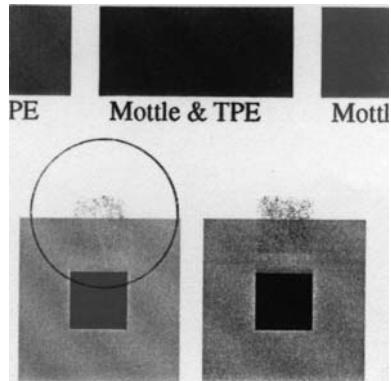
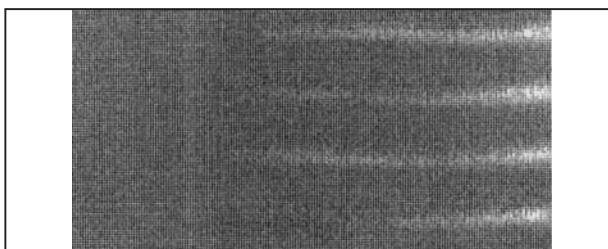

Image of preceding page appears on every other page.

	Problem area	Action
1	Transfer unit cleaning roller	Cleaning roller is not installed properly. Remove and reinstall. Ensure left side of cleaning roller is making good contact with HVPS contact. If error continues to occur after reinstallation, replace cleaning roller. See “Transfer belt cleaning roller removal” on page 4-4.
2	HVPS	Replace faulty HVPS. See “High voltage power supply (HVPS) removal” on page 4-40.

Ribbing service check



Light print occurs in right or left side of image.

	Problem area	Action
1	Printer is not level	Table printer is sitting on is slightly tilted. Tilt should be less than 1/2 inch. Confirm the printer table is large enough and the printer is level.
2	Toner cartridge	insufficient amount of toner in the toner cartridge. Shake the toner cartridge horizontally several times to level the toner.
3	Toner cartridge	Toner in the toner cartridge is not level and collects on one side. Shake the toner cartridge horizontally several times to level the toner. If problem persists, replace toner cartridge.
4	Rear cover assembly	Open rear cover assembly, and close properly.
5	Photodeveloper cartridge	Photodeveloper OPC belt is off rack and becomes deformed during operation. Replace photodeveloper cartridge. See “Photodeveloper cartridge removal” on page 4-8. Note: Photodeveloper cartridge is a customer order supply.

Smear service check

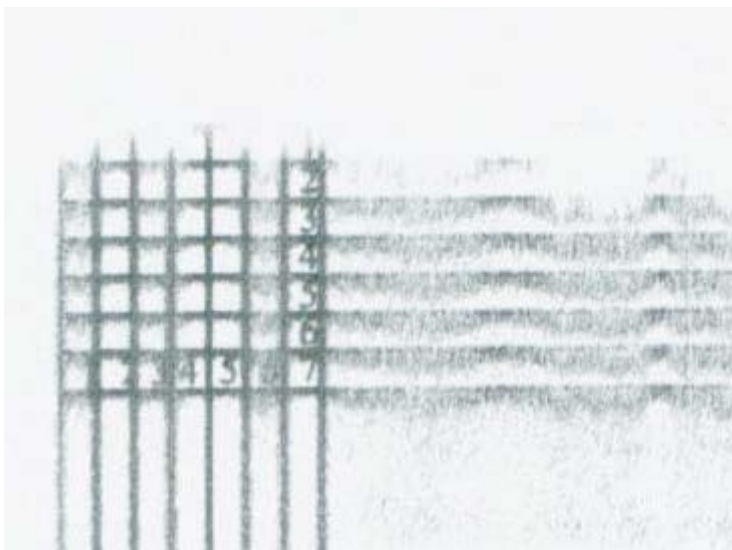

The entire image appears smudged.

	Problem area	Action
1	Photodeveloper cartridge (OPC belt) and transfer belt	<p>This print quality issue is usually accompanied by a paper jam.</p> <p>Remove the photodeveloper cartridge, and check for a piece of paper on the rear side of the photodeveloper cartridge. Remove the piece of paper from the photodeveloper.</p> <p>Note: This occurs mostly with A5 and B5 size media.</p>

Toner drop service check

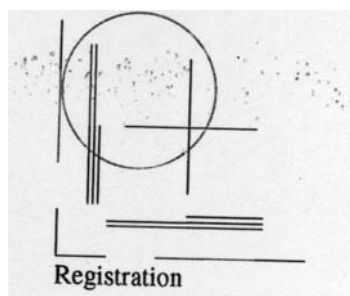

A toner spot stain on paper is caused by ambient toner within printer engine.

	Problem area	Action
1	Waste toner feed system <ul style="list-style-type: none"> • Waste toner auger • Waste toner feeder 	Toner drops on the transfer drum due to a breakdown of the waste toner feed system. <ul style="list-style-type: none"> • Waste toner auger mylar is damaged. Examine and replace if defective. See “Waste toner auger removal” on page 4-48. • Waste toner is not properly collected by waste toner feeder. Check to ensure that waste toner feeder is not compacted. If so, replace waste toner feeder. See “Waste toner feeder removal” on page 4-28. • Check for waste toner in printer. If found, clean and vacuum printer.
2	Transfer unit cleaning roller	Cleaning roller is faulty. Remove transfer belt unit (see “Transfer belt unit removal” on page 4-5). Replace cleaning roller. See “Transfer belt cleaning roller removal” on page 4-4 . Prior to installation of new cleaning roller, thoroughly clean cleaning roller installation area. Check for waste toner in printer. If found, clean and vacuum printer.
3	Toner cartridge	Replace faulty toner cartridge.

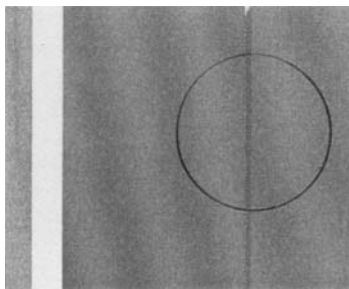
Vertical line service check

A vertical line appears in printed image.

	Problem area	Action
1	Photodeveloper cartridge (OPC belt) and transfer belt	Foreign particles (dust and so on) adhere to parts located around photodeveloper cartridge and transfer belt unit which consequently contact toner image on transfer belt unit. Remove and clean photodeveloper cartridge, transfer belt unit, and adjacent areas.
2	Transfer unit cleaning roller and waste toner auger	Cleaning roller and waste toner auger area are dirty. Remove cleaning roller and clean waste toner auger and area around it. Reinstall cleaning roller.

Vertical staggering image service check

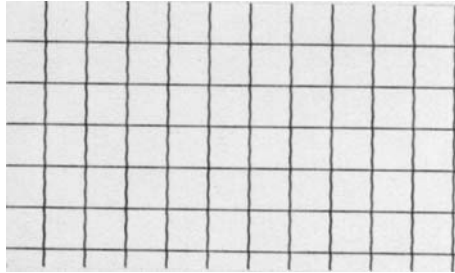

Printed image staggers in vertical direction.

	Problem area	Action
1	Printer vibration	Check for printer vibrations or shock to printer.
2	Laser unit assembly (printhead)	Optical unit failure caused by vibration from scanner motor rotation. Replace laser unit assembly. See “Upper right rear cover removal” on page 4-17.

Vertical white band service check

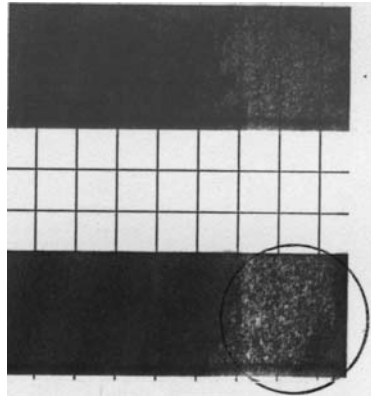

White band appears in vertical direction of printed image.

	Problem area	Action
1	Toner cartridge	Replace faulty toner cartridge.
2	Photodeveloper cartridge	Replace faulty photodeveloper cartridge. See “Photodeveloper cartridge removal” on page 4-8.
3	Transfer belt unit	Replace faulty transfer belt unit. See “Transfer belt unit removal” on page 4-5.

White band service check

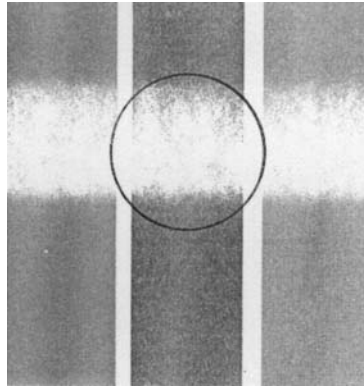

Horizontal white banding creates missing portion of image.

	Problem area	Action
1	Transfer roller	<ul style="list-style-type: none"> • Transfer roller bias pole is not making proper contact with high voltage spring contact. Remove and reinstall transfer roller. Ensure spring contact on left side (looking from front of printer) is not damaged. • Replace faulty transfer roller. See “Transfer roller removal” on page 4-6.
2	Transfer roller clutch	Replace faulty transfer roller clutch. See “Clutch removal” on page 4-27.

White line I service check

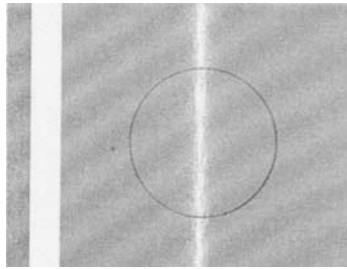

Vertical white line appears in a specific color area when print quality test print is run.

	Problem area	Action
1	Test print	Print the maintenance page. See “Printing the maintenance and configuration pages” on page 3-3 . White line appears on specific color.
2	Toner cartridge	<ul style="list-style-type: none"> • Developer roller of specific toner cartridge is dirty. Remove foreign particle adhering to specific toner cartridge developer roller. • Developer roller surface is damaged. Replace problem toner cartridge.

White line II service check

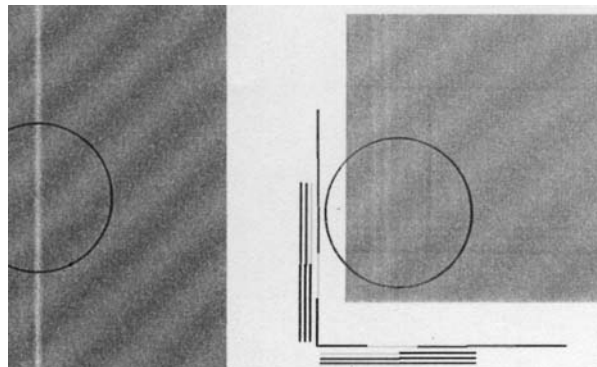

Vertical white line appears from leading edge to trailing edge of printed image.

	Problem area	Action
1	Laser unit assembly (printhead)	Dust-proof glass of laser unit is smeared with toner or foreign particles. Clean glass: <ul style="list-style-type: none"> • Remove toner cartridges and photodeveloper cartridge. See “Photodeveloper cartridge removal” on page 4-8. • Open dust-proof glass cover. • Clean glass. There are foreign particles adhering to laser beam opening of printhead. Clean laser beam opening.
2	Toner cartridge	Foreign particles mixed in toner cartridge. Replace faulty cartridge.

White spot / black spot service check

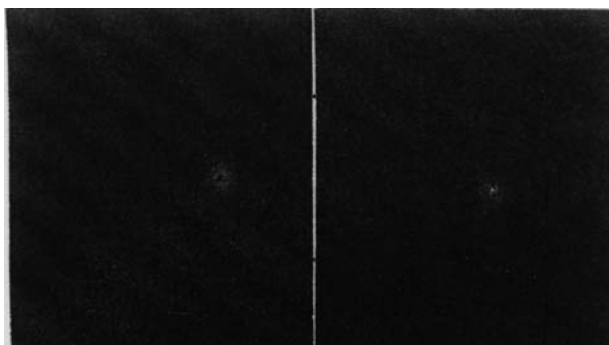

A white spot and black spot appear on paper.

	Problem area	Action
1	Photodeveloper cartridge	There are foreign particles adhering to photodeveloper OPC belt. Remove photodeveloper cartridge (see “Photodeveloper cartridge removal” on page 4-8). Lightly wipe off foreign particles using a cotton cloth. If problem persists, replace photodeveloper cartridge.
2	Transfer belt unit	There are foreign particles adhering to transfer belt unit. Remove transfer belt unit (see “Transfer belt unit removal” on page 4-5). Lightly wipe off foreign particles using a cotton cloth. If problem persists, replace transfer belt unit.
3	Toner cartridge	Foreign particles mixed in toner. Replace toner cartridge.
4	Transfer roller	There are foreign particles adhering to transfer roller, or transfer roller is deformed. Replace transfer roller. See “Transfer roller removal” on page 4-6 .

White print service check

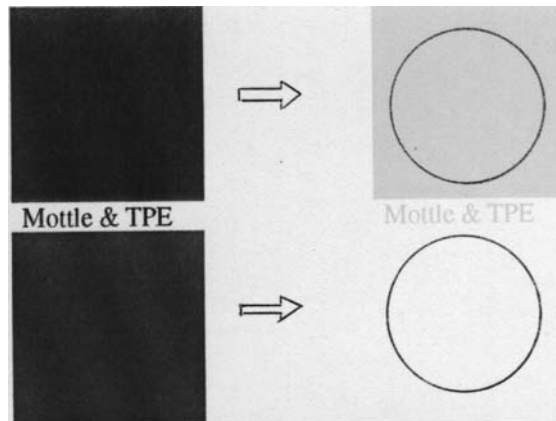

Blank page (no print at all) is printed or, a specific color is missing.

	Problem area	Action
Solid white print		
1	Optical Unit (Printhead)	Laser light path is blocked by paper or other material stuck at the opening of the optical unit. Ensure there are no foreign particles stuck at the opening of the optical unit.
2	Transfer roller	Transfer roller is not properly installed. Remove transfer roller and reinstall. See “Transfer roller removal” on page 4-6. Ensure transfer roller bias pole is touching spring contact on left side (as viewed from front of printer) of roller.
3	HVPS	Replace faulty HVPS. See “High voltage power supply (HVPS) removal” on page 4-40.
One color missing		
4	Toner cartridge	Replace faulty toner cartridge.

Wrinkle / image migration service check

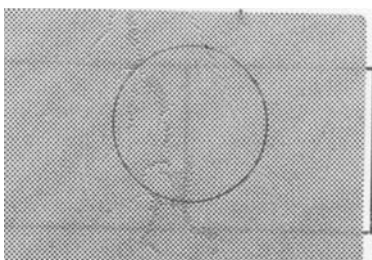

Banding shadows of different optical density appear due to wrinkle, image migration, and color misregistration occurring on paper.

	Problem area	Action
1	Non-recommended paper	Paper being used is not recommended for printer. Replace paper with recommended paper.
2	Rear cover assembly	Open rear cover assembly and reclose, ensuring that both sides properly latch.
3	Fuser assembly	<ul style="list-style-type: none"> • Ensure fuser assembly is properly installed and that both locking levers are locked. See “Fuser assembly removal” on page 4-6. • Replace faulty fuser assembly. <p>Note: Fuser assembly is a customer order supply.</p>

Uneven density (right and left)

Optical density is different between right and left side of printed image.

	Problem area	Action
1	Rear cover assembly	Open rear cover assembly and reclose, ensuring that both sides properly latch. If rear cover assembly will not properly latch, ensure that white door actuators located at top of rear cover assembly are not damaged. If damaged, replace. These items are part of parts packet. If actuators are not damaged, and door will still not latch, replace rear cover assembly. See “Rear cover assembly removal” on page 4-14.
2	Transfer roller	Transfer roller is not properly installed. Remove transfer roller and reinstall. See “Transfer roller removal” on page 4-6. Ensure transfer roller bias pole is touching spring contact on left side (as viewed from front of printer) of roller.
3	Laser unit assembly (printhead)	Dust-proof glass of laser unit is smeared with toner or foreign particles. Clean glass: <ul style="list-style-type: none"> • Remove toner cartridges and photodeveloper cartridge. See “Photodeveloper cartridge removal” on page 4-8. • Open glass cover. • Clean glass. There are foreign particles adhering to laser beam opening of printhead. Clean laser beam opening.
4	Toner cartridge	Toner cartridge has insufficient amount of toner. Replace toner cartridge.
5	Photodeveloper cartridge	Replace faulty photodeveloper cartridge. See “Photodeveloper cartridge removal” on page 4-8.
6	Transfer belt unit	Replace faulty transfer belt unit. See “Transfer belt unit removal” on page 4-5.

Spacing table

Roller specifications

Name of roller	Diameter (mm)	Number of rotations (rpm)	Repeating defect on print (mm)
Registration assembly rubber roller	ø 14	283	43
Registration assembly steel roller	ø 12	321	38
Transfer roller	ø 20	194	63
Developer roller	ø 18	345	35
Transfer belt drive roller (part of transfer belt unit)	ø 30	128	95
Transfer belt cleaning roller	ø 26	182	67
OPC belt charge brush (part of photodeveloper charging system)	ø 11	256	47
OPC belt charge roller (part of photodeveloper charging system)	ø 11	352	34.5
OPC belt drive gear shaft	ø 5	256	47
OPC belt drive roller	ø 30	128	95
Fuser roller (part of fuser)	ø 41	95	128
Fuser belt (part of fuser)	ø 30	128	95
Paper exit roller (part of paper exit assembly)	ø 16	246	50

7100-XXX

3. Diagnostic aids

This chapter explains the tests and procedures to identify MFP failures and to verify repairs have corrected the problem.

Understanding the MFP operator panel

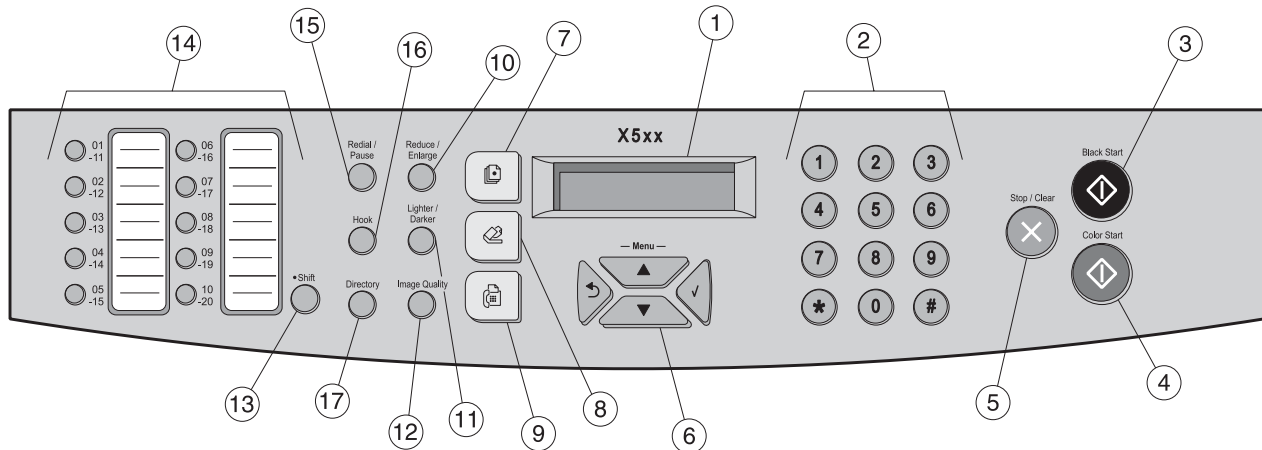

The use of the buttons and the layout of the operator panel is described in the following table.

Number	Button	Function
1	LCD Display	All modes - Displays messages and prompts during operation. Displays settings when new settings are specified.
2	Alpha / Numeric Keys	Enters numbers and letters in the setting menu. Copy mode – Enter copy quantity. Scan mode – Enter ASCII characters for a Push Scan profile search. Fax mode – Enter a Fax number. Enter ASCII characters for Fax speed dial searches.
3	Black Start	initiates a black and white scan job in Copy and Scan modes. initiates the Fax TX in Fax mode.
4	Color Start	initiates a color scan in Copy and Scan modes. Non functional in Fax mode.
5	Stop / Clear	Cancels copy, scan, and fax jobs.
6	Menu Keys	▲ ▼ Up / Down keys – These keys are used to scroll through selections. ▲ can be used to clear an item, and ▼ can be used to enter a space.
		↶ Return – Exits to an upper level of a menu.
		✓ Select – This key is used to select and confirm settings, or enter a submenu.
7	Copy LED	Switches the MFP to Copy mode.
8	Scan LED	Switches the MFP to Scan mode.
9	Fax LED	Switches the MFP to Fax mode.

Number	Button	Function
10	Reduce / Enlarge	Copy mode - Reduce or enlarge the image data to a copy job. Scan mode - Select the push scan document size.
11	Lighter / Darker	Copy mode - Adjust the copy exposure (5 levels available). Scan mode - Adjust the push scan density (5 levels available). Fax mode - Adjust the fax contrast (3 levels).
12	Image Quality	Copy mode - Select the desired copy quality (Text, Photo, Mixed). Scan mode - Select Push scan resolution. Fax mode - Select the Fax resolution (Standard, Fine, Photo).
13	Shift	Press to access the other 10 speed dial settings.
14	Speed Dial (One touch dial)	Scan mode - One touch key for Push Scan with one shift key to switch to 20 sets. Fax mode - One touch key for Fax with one shift key to switch to 20 sets.
15	Re dial Pause	Scan mode - Display the latest push scan profile. Fax mode - Redial or pause a Fax job.
16	Hook	Fax mode - Hook
17	Directory	Scan mode - Search Push Scan profile by name for a Push Scan job. Fax Mode - Search Fax phone numbers by name or speed dial code.

Retrieving, printing and restoring the MFP settings

Printing the maintenance and configuration pages

Before replacing the engine controller board or the system / RIP board, print out the maintenance and configuration pages. These page contain the MFP setting information that will need to be reset on the new board.

Printing the maintenance page

1. in **Ready** mode, press ▲. The MFP will enter the admin menus.
2. Press ▲ twice to scroll to the **Reports** menu.
3. Press ✓.
4. Press ▼ once to scroll to the **Maintenance Page** item.
5. Press and hold ✓. The maintenance page will print out.

Printing the configuration page

1. in **Ready** mode, press ▲. The MFP will enter the admin menus.
2. Press ▲ twice to scroll to the **Reports** menu.
3. Press ✓.
4. Press ▼ XX times to scroll to **Configuration Page**.
5. Press and hold ✓. The configuration page will print out.

Setting the country code

The country code must be reset when the system/RIP board is replaced. The country code setting determines which communication protocols, compression settings, and signal strength settings will be used for a given country or region. Failure to reset the country code can render the fax functionality unusable.

To set the country code, perform the following steps:

1. in **Ready** mode, press ✓ to enter the MFP menus.
2. Use the ▲ or ▼ keys to scroll to the **Administration** menu.
3. Press ✓ to select the **Administration** menu.
4. Use the ▲ or ▼ keys to scroll to the **Country** menu.
5. Use the ▲ or ▼ keys to scroll to the desired country or region.
6. Press ✓ to select and confirm the country or region.

Scanner calibration and registration

The X5xx scanner is self-calibrating. Scanner calibration occurs every time the MFP is started. In addition, calibration is performed before a scan, copy or fax action is performed.

Top edge registration is performed when the MFP is powered on and before every scan, copy, or fax. Right and left edge registrations are performed only when the MFP is started.

If the scanner fails to calibrate, 006 Service Call / Scanner Unit will be displayed. Should this error display, see **“Flatbed service check” on page 2-41**.

Maintenance mode

Maintenance mode contains information and settings that can be used in servicing the X5xx series MFPs. The maintenance mode menu is entered by holding down the ▲ key when performing a POR. The various items in maintenance mode are accessed by using the ▲ and ▼ keys to navigate within a submenu to each item, and pressing the ✓ to select the item. Press the ↶ key to move up a level.

WARNING: These settings should not be used without the supervision of your secondary support center.

Display info

The default menu displayed when in maintenance mode is the **Display info** menu. To select this menu item, press the ✓ key. The Display info menu item contains printer-specific information. The information in this menu is described below. Press ✓ to exit this menu.

Model Name

Model Name is the default menu item in the **Display info** submenu. This item displays the MFP model name. The options are X500, and X502. This item cannot be changed. Press ↶ to exit this item.

FW Version

The **FW Version** submenu displays three different firmware related items. While in the **Display info** menu, use the ▲ and ▼ keys to navigate to **FW Version** and press the ✓ key to enter the submenu. **FW Version** menu items are accessed by using the ▲ and ▼ keys to navigate within the submenu to each item.

CTL FW Ver

CTL FW Ver displays the system board firmware version. It cannot be changed in the menu. This is the default menu item in the **FW Version** submenu. Press ↶ to exit this item.

Fax FW Ver

The second item is **Fax FW Ver** which displays the fax firmware version. It cannot be changed in the menu. Press ↶ to exit this item.

MCTL FW Ver

The third item is **MCTL FW Ver** which displays the engine controller board firmware version. It cannot be changed in the menu. Press ↶ to exit this item.

Press ↶ to go back up to the **Display info** menu.

Counter

The **Counter** submenu displays various counters maintained by the MFP. These are permanent counts. While in the **Display info** menu, use the ▲ and ▼ keys to navigate to **Counter** and press the ✓ key to enter the submenu. **Counter** menu items are accessed by using the ▲ and ▼ keys to navigate within the submenu to each item.

Printer Counter - This submenu maintains the base print engine counters. Use the ▲ and ▼ keys to navigate to each counter within the submenu. Press ✓ to select the displayed item. Press ↻ to exit an item.

1. Total page – Total number of pages printed
2. Total Image – Number of images printed
3. Black Image – Number of black color planes printed
4. Magenta – Number of magenta color planes printed
5. Cyan – Number of cyan color planes printed
6. Yellow – Number of yellow color planes printed

Scanner Counter - This submenu item displays the number of various scans performed by the MFP. Use the ▲ and ▼ keys to navigate to each counter within the submenu. Press ✓ to select the displayed item. Press ↻ to exit an item.

1. Total Page – Total number of pages scanned
2. Total Image – Total number of images
3. Black Page – Total number of black and white scans
4. Color Page – Total number of color scans
5. ADF Used – Total number of scans from the ADF

Jam Counter - This menu shows the number of jams in various areas of the MFP. Use the ▲ and ▼ keys to navigate to each counter within the submenu. Press ✓ to select the displayed item. Press ↻ to exit an item.

1. Total – Total number of jams
2. ADF – Total number of ADF jams
3. Prt Output Bin – Total number of jams in the fuser area
4. internal – Total number of jams in the paper path
5. Tray 1 – Total number of paper tray jams.

Press ↻ again to exit the Counter menu.

Print Reports

Print Reports is the second top level menu item. From the top level of the Maintenance mode menu, use the ▲ and ▼ keys to navigate to **Print Reports**. Press ✓ to select the **Print Reports** item.

G3 Protocol Dump List - This is the only menu item in the **Print Reports** submenu. This setting converts inbound fax data into ASCII data to aid in troubleshooting fax issues. Press ✓ to select this item.

Press ↻ twice to return to the top level of the Maintenance mode menu.

Engine maintenance

This submenu shows the replacement status of the various maintenance items on the MFP. From the top level of the Maintenance mode menu, use the ▲ and ▼ keys to navigate to **Engine Maintenance**. Press ✓ to select the **Engine Maintenance** item. Use the ▲ and ▼ keys to navigate to the individual settings in the **Engine Maintenance** menu. Press ✓ to select the currently displayed item.

Replace OPC Belt

Replace Fuser

Replace TR Belt

Replace PQ Kit

Replace PF1 Kit

Replace PF2 Kit

Replace ADF Kit

Waste Toner Pack Life Setting -

To change the status of any item, use the ▲ key to scroll to the desired setting and press the ✓ key.

Press ↶ twice to return to the top level of the Maintenance mode menu.

Scan Maintenance

Mono Compression Setting - This item lets you change the scan compression settings. The options are MH, MR, and MMR. MH is the default setting. This is the only item in the **Scan Maintenance** menu.

Fax Maintenance

Modem Settings

The three modem settings submenu items can be accessed using the ▲ and ▼ keys to navigate to the individual settings. When the desired modem setting is displayed, press ✓ to select the item.

RX Level — This item allows you to adjust the RX level. The options are 16, 26, 33, and 43 dBm. XXX is the default. This setting is automatically set when the MFP is initialized at setup. Do not change this setting without second-level support supervision. If the setting needs to be adjusted use the ▲ and ▼ keys to navigate to the setting level, and press ✓ to select the new setting. Press ↶ to exit.

TX Level – This item allows you to adjust the TX level. The options are 0 to 15 dBm. 15 dBm is the default. This setting is automatically set when the MFP is initialized at setup. Do not change this setting without second-level support supervision. If the setting needs to be adjusted, use the ▲ and ▼ keys to navigate to the setting level, and press ✓ to select the new setting. Press ↶ to exit.

Cable Equalizer – This setting affect signal attenuation distance and the physical distance the fax can be from a repeater. The options available for this setting are 0 km, 1.8 km, 3.6 km, and 7.2 km. Do not change this setting. If the setting needs to be adjusted, use the ▲ and ▼ keys to navigate to the setting level, and press ✓ to select the new setting. Press ↶ to exit.

Protocol Definition

The two submenu items can be accessed using the ▲ and ▼ keys to navigate to the individual settings. When the desired protocol definition setting is displayed, press ✓ to select the item.

Training Retries – This is the number of attempts made to receive a fax before switching to a different compression setting. When **Training Retries** is selected, use the ▲ and ▼ keys to navigate to the desired number of retries, and press ✓ to select the new setting. Press ↻ to exit.

Encoding – This allows you set the fax compression setting. The options are JBIG, MMR, MR, and MH. This can also be changed in the user menus. When **Encoding** is selected, use the ▲ and ▼ keys to navigate to the desired encoding, and press ✓ to select the new setting. Press ↻ to exit.

Protocol Definition Timer – These settings affect the time duration before a protocol used to transmit a fax is switched. This setting is country or region dependent and should not be changed without supervision of a second-level support person.

T0 Timer

T1 Timer

T4 Timer

RX Settings

Silence Detection Time

CNG Tone Detection Time

CNG Cycles

Tone Sound Monitoring

Stop / Clear Key - This makes the key functional or non-functional.

Density Tune Up

These settings adjust the density of the separate color planes for the copy, scan, and fax functions. These settings should not be adjusted without second-level support center supervision.

The density tune-up menu items can be accessed using the ▲ and ▼ keys to navigate to the individual settings. When the desired modem setting is displayed, press ✓ to select the item.

Copy

The **COPY** settings submenu items can be accessed using the ▲ and ▼ keys to navigate to the individual settings. When the desired modem setting is displayed, press ✓ to select the item. Each individual density setting can be adjusted by using the ▲ and ▼ to increment or decrement the density value. When the desired value is displayed, press ✓ to accept and set the value. Press ↻ to exit the submenu item.

Density Notch 1 (0-255) +127 is the default.

Density Notch 2 (0-255) +127 is the default.

Density Notch 3 (0-255) +127 is the default.

Density Notch 4 (0-255) +127 is the default.

Density Notch 5 (0-255) +127 is the default.

Scan

The **SCAN** settings submenu items can be accessed using the ▲ and ▼ keys to navigate to the individual settings. When the desired setting is displayed, press ✓ to select the item. Each individual density setting can be adjusted by using the ▲ and ▼ to increment or decrement the density value. When the desired value is displayed, press ✓ to accept and set the value. Press ↻ to exit the submenu item.

Density Notch 1 (0-255) +127 is the default.

Density Notch 2 (0-255) +127 is the default.

Density Notch 3 (0-255) +127 is the default.

Density Notch 4 (0-255) +127 is the default.

Density Notch 5 (0-255) +127 is the default.

Fax

The **FAX** settings submenu items can be accessed using the ▲ and ▼ keys to navigate to the individual settings. When the desired setting is displayed, press ✓ to select the item. Each individual density setting can be adjusted by using the ▲ and ▼ to increment or decrement the density value. When the desired value is displayed, press ✓ to accept and set the value. Press ↻ to exit the submenu item.

Normal (0-255) +127 is the default.

Dark (0-255) +127 is the default.

Light (0-255) +127 is the default.

Printer theory of operation

Electrophotographic Process (EP process)

The method that all laser and LED printers use to print is called the electrophotographic process. Laser printers use differences in charge to manipulate and move toner from the toner cartridge to the printed page.

Even though the basic EP Process is the same for every laser and LED printer, the specifics for each printer are different. We will discuss the Lexmark X500n MFP and its particular method of printing.

EP Basics

The Lexmark X500n is a single laser MFP that uses four toner cartridges (Cyan, Yellow, Magenta and Black) to create text and images on media. The MFP has one photodeveloper (called a photodeveloper cartridge or OPC) and a transfer Unit. Each color toner is painted to the photodeveloper and to the transfer unit one color or "image" at a time. The photodeveloper and transfer unit must rotate four times to print one page composed of the four images for a color print job. During the printing process, the printer follows the six basic EP process steps to create its output to the page.

These six steps are:

1. Charge the photodeveloper (OPC)
2. Expose the photodeveloper (OPC)
3. Develop toner on the photodeveloper (OPC)
4. 1st and 2nd transfer of toner to the transfer Unit and then to the media
5. Fuse toner to the media
6. Clean/Erase the photodeveloper and transfer Unit

In summary, the printer RIP board receives the command to print. The RIP board then sends a signal to the engine controller board to start the print process. The engine controller board is the command center for the EP process. The engine card coordinates the various clutches, motors and signals.

The high voltage power supply sends a charge to various components in the EP process. The laser fires on the photodeveloper and creates an invisible image on the surface. One toner cartridge is pushed against the photodeveloper for each rotation of the OPC, and toner is developed on the surface of the OPC. The image is then transferred to the transfer unit and the photodeveloper is cleaned and electrically erased. This process continues until all four colors have been transferred to the transfer unit.

Media is picked up from the tray and carried to the registration rollers where it stops and it is timed to enter the EP process at just the right moment. Next, it is carried to the transfer roller where the image is transferred from the Transfer Unit to the media.

The media is carried to the fuser rollers, where heat and pressure are applied to the page to permanently bond the toner to the page. The fuser rollers push the media into the output bin. The transfer unit is cleaned, and the process begins again for the next page.

Summary of the EP process on the X500

This graphic illustrates the steps of the EP process on the X500

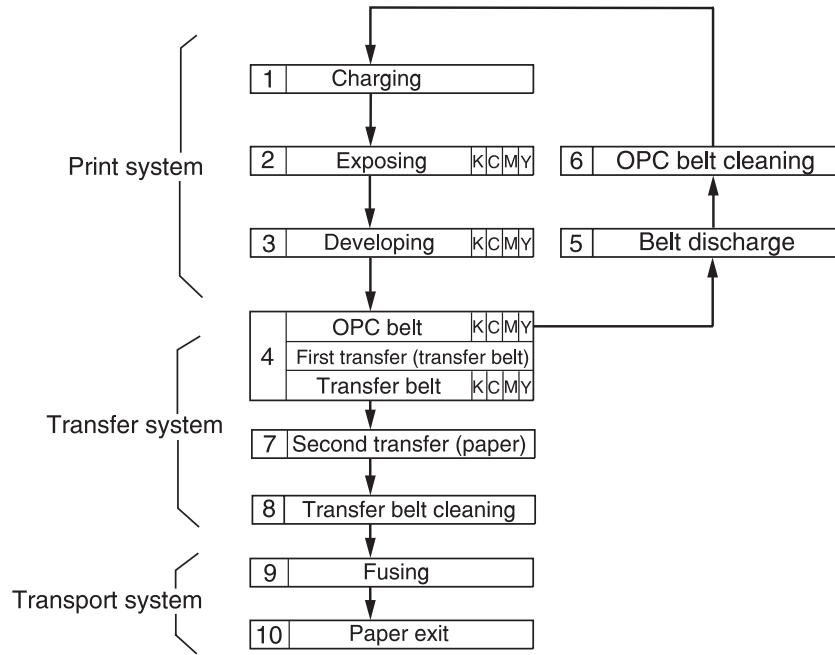

X500 EP steps in detail

Step 1: Charge

During the charge step, voltage is sent from the high voltage power supply to the charge roller inside the photodeveloper. The charge roller is part of the photodeveloper unit.

The charge roller puts a uniform negative charge over the entire surface of the photodeveloper to prepare it for the laser beam. This is the charge process.

Look at callout 1 in the picture below. This is the location of the charge roller inside the photodeveloper. The charge roller is the main component in step 1 of the EP process.

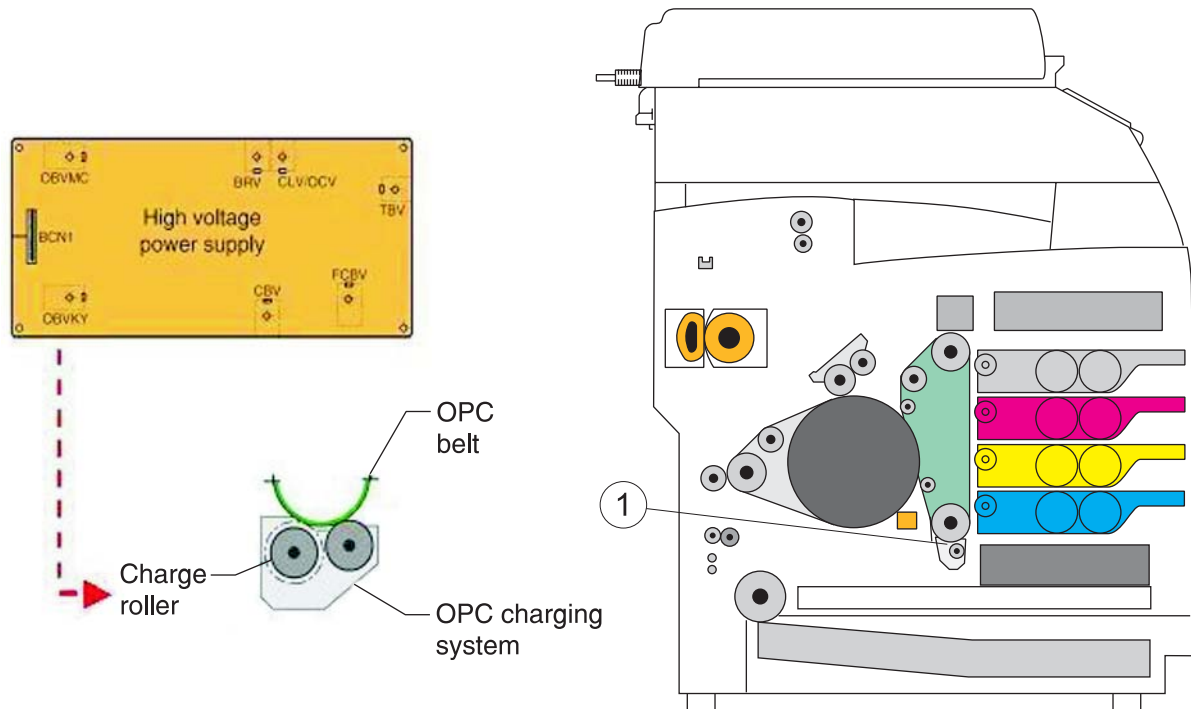

Note: If the surface of the charge roller is damaged (such as a nick or pit), it will cause the charge to be uneven on the photodeveloper. This will cause a repeating mark on the printed page. Check the service manual for the repeating marks table.

Note: If the charge roller is severely damaged, the surface of the photodeveloper will not be charged properly and heavy amounts of toner will be deposited on the photodeveloper. This will cause the printed page to be saturated with 100% of each color.

Step 2: Expose

During the expose step, the laser fires a focused beam of light at the surface of the photodeveloper and writes an invisible image called a latent image or electrostatic image. This is repeated for each color printed. This is the expose process.

The laser beam actually discharges the surface only where the beam hits the photodeveloper. This creates a difference in charge potential between the exposed area and the rest of the photodeveloper surface.

Look at callout 2 in the picture below. This is the where the laser beam hits the photodeveloper in Step 2 of the EP process.

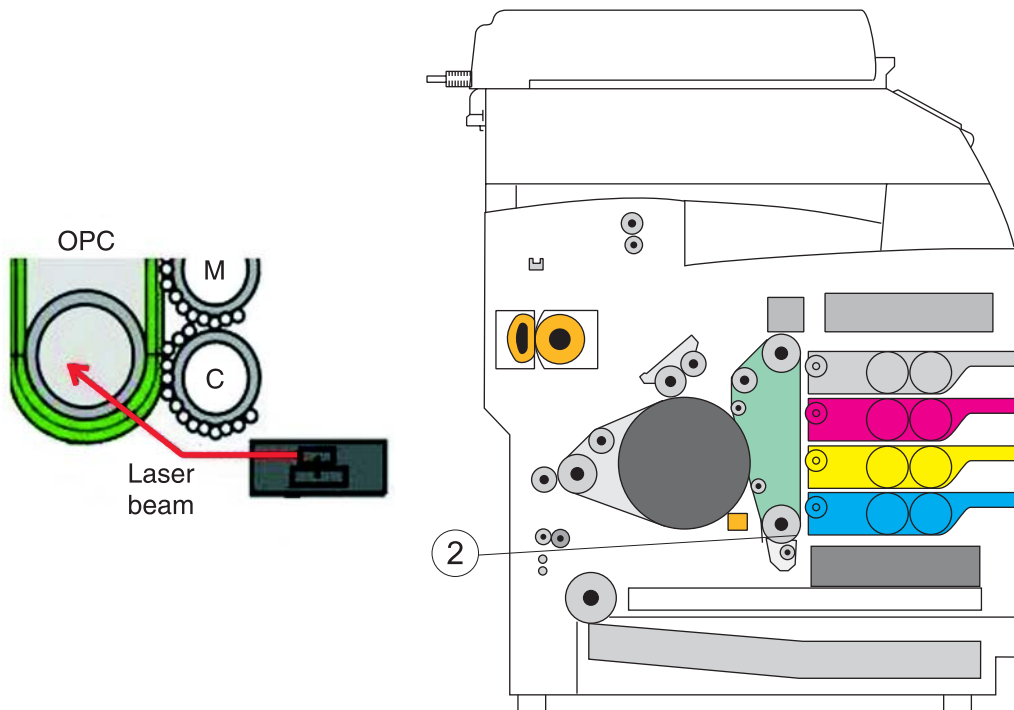

Note: The laser beam passes through a glass lens as it exits the laser unit. If this lens gets contaminated with toner or other debris, it will cause vertical streaking of white/lightness on the page. Cleaning the lens will solve the problem.

Note: Never touch the surface of the photodeveloper with your bare hand. The oil from your skin may cause a charge differential on the surface, and toner will not stick properly. The result would be repeating blotches of voids/light print on a page. Then the photodeveloper will have to be replaced.

Note: The surface of the photodeveloper is coated with an organic substance that makes it sensitive to light. Be sure and cover the photodeveloper when you are working on the printer so you don't "burn" it. If exposed to light for too long, it will cause light/dark print quality problems and have to be replaced.

Step 3: Develop

Once the laser exposes the photodeveloper, the high voltage power supply sends a charge to the developer roller. The first toner cartridge engages the photodeveloper so it is in contact with the surface. Because of the charge difference between the toner on the developer roller and the electrostatic image created by the laser, the toner will cling to the OPC. The toner will only stick where the laser exposed the surface. This is the develop process.

This process is best illustrated by comparing it to using glue to write on a can and then rolling it over glitter. The glitter sticks to the glue but won't stick to the rest of the can.

Each toner image is developed and transferred to the photodeveloper one color at a time. The toner image on the photodeveloper needs to be transferred to the transfer unit before the next color can be developed.

Look at callout 3 in the picture below. This is where the developer rollers in the toner cartridges touch the surface of the photodeveloper during Step 3 of the EP Process.

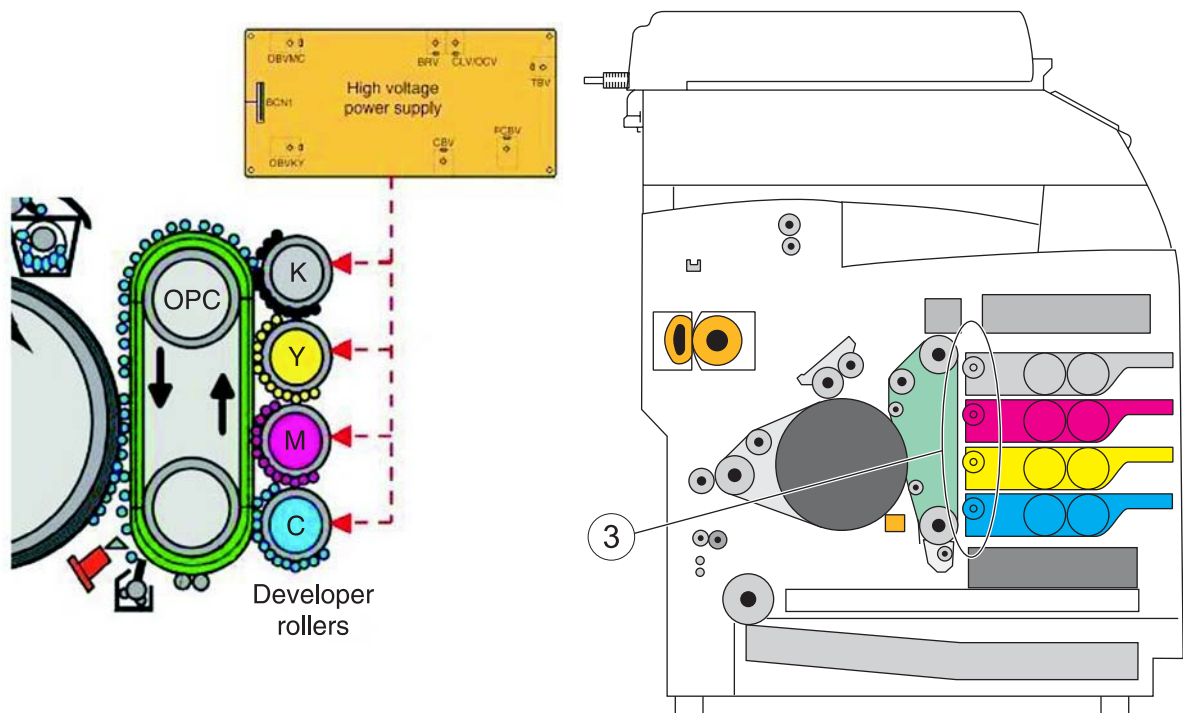

Note: If the developer roller is damaged, it will not contact the surface of the photodeveloper properly. The result could be repeating marks, thin vertical voids or thin vertical lines of color on the printed page. Check the surface of the developer for damage.

Note: Never touch the surface of the developer roller with your bare hand. The oil from your skin may cause a charge differential on the surface, and toner will not stick properly. The result would be repeating blotches of voids/light print on a page. Then the affected cartridge would need to be replaced.

Step 4: Transfer

First transfer

After the first plane of color is developed on the photodeveloper, the high voltage power supply sends voltage to the transfer unit so the image on the photodeveloper is transferred to the transfer unit. This takes place by a direct surface-to-surface contact between the photodeveloper and the transfer unit. This is the first transfer process.

The photodeveloper continues to rotate around and is cleaned and erased. Then, a new charge is put on the surface. The laser exposes the photodeveloper, and the next color is developed and transferred to the transfer unit. This process continues until all four planes of color have been transferred to the transfer unit.

Look at callout 4 in the picture below. This is the where the photodeveloper transfers the toner to the transfer unit and the first transfer of the EP Process.

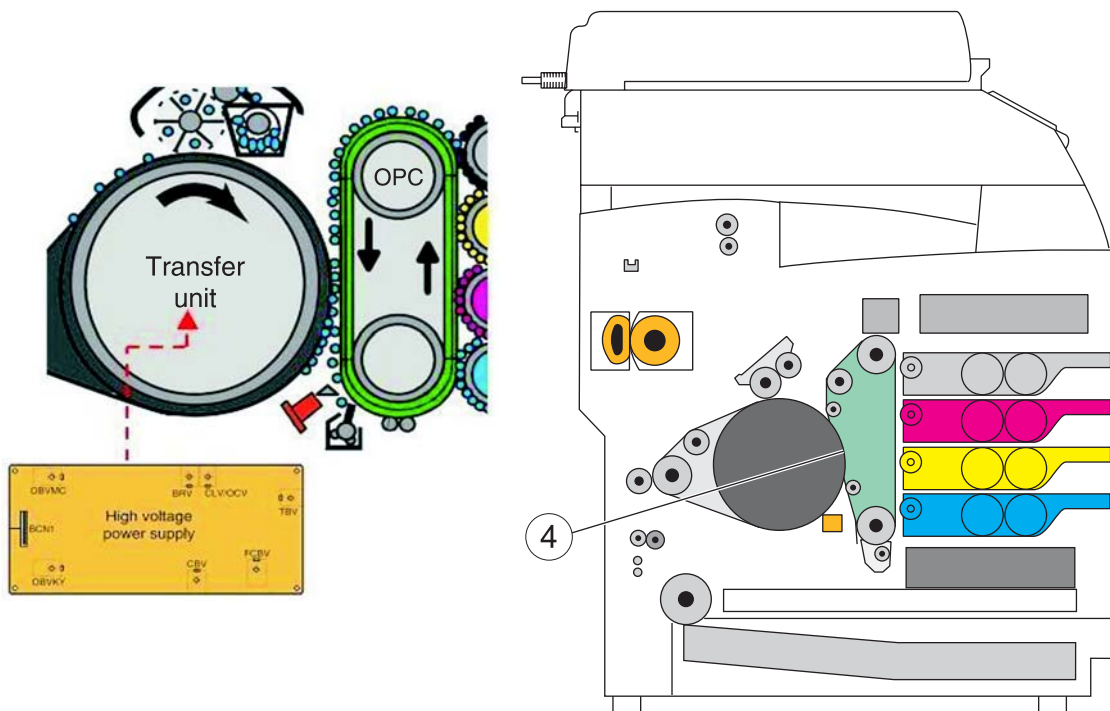

Note: Never touch the surface of the transfer unit with your bare hand. The oil from your skin will cause a charge differential on the surface and toner will not stick properly. The result would be repeating blotches of voids/light print on a page. The transfer unit would need to be replaced.

Note: Don't use solvents or other cleaners to clean the transfer unit surface. No matter how careful you are, the surface will be compromised causing scratches or a charge differential that will produce a void or light blotch on the printed page. The transfer unit would need to be replaced.

Second transfer

Once the last plane of color is transferred to the transfer unit from the photodeveloper, media is picked from the paper tray and carried to the transfer roller. The transfer unit continues to rotate around and meets the paper at the Transfer Roller area.

The high voltage power supply sends voltage to the transfer roller to create a positive charge. Once the paper passes between the transfer roller and transfer unit, the negatively charged toner clings to the paper and the entire image is transferred from the transfer unit. This is the 2nd transfer process.

Look at callout 4 in the picture below. This is the where the transfer unit transfers the toner to the media by way of the transfer roller and Step 4b of the EP process.

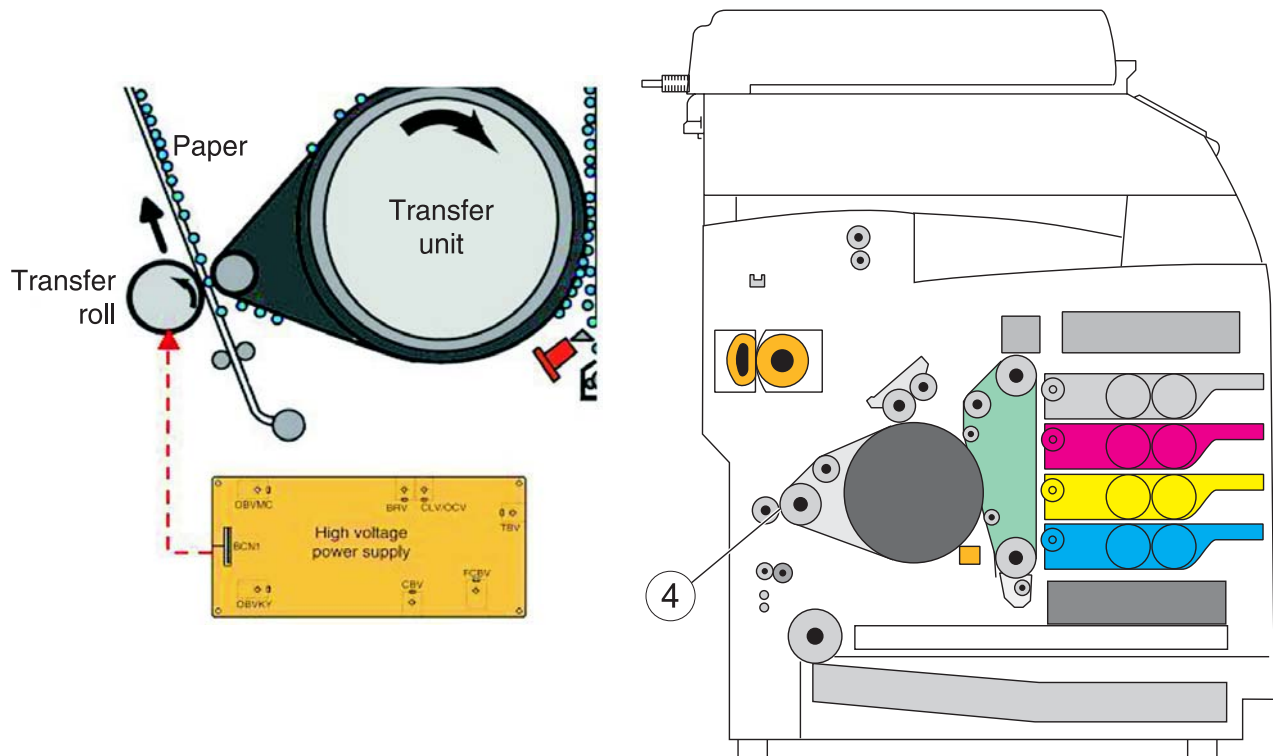

Note: If the transfer roller has nicks, pits or flat spots on it, the surface doesn't come into contact with the media and transfer unit properly. This will cause voids or lights spots on the page or repeating voids/light areas, because the toner can't be fully transferred due to the charge difference in the areas of damage.

Note: If the transfer roller does not engage the transfer unit, or does not have voltage coming from the high voltage power supply, the toner will not fully transfer from the transfer unit; the entire page will be very light or blank. Any toner that does transfer will be due to a "contact" transfer instead of a "charge" transfer. Check the transfer roller clutch and the high voltage power supply contacts to the transfer roller.

Step 5: Fuse

Once the image has been fully transferred to the media, the transfer roller helps move the paper into the fuser area.

The fuser applies heat and pressure to the page to melt the tiny toner particles and bond them permanently to the media. The fuser moves the paper from the rollers and into the exit bin. This is the Fuse Process.

Look at callout 5 in the picture below. This is the where the Fuser bonds the toner permanently on the page.

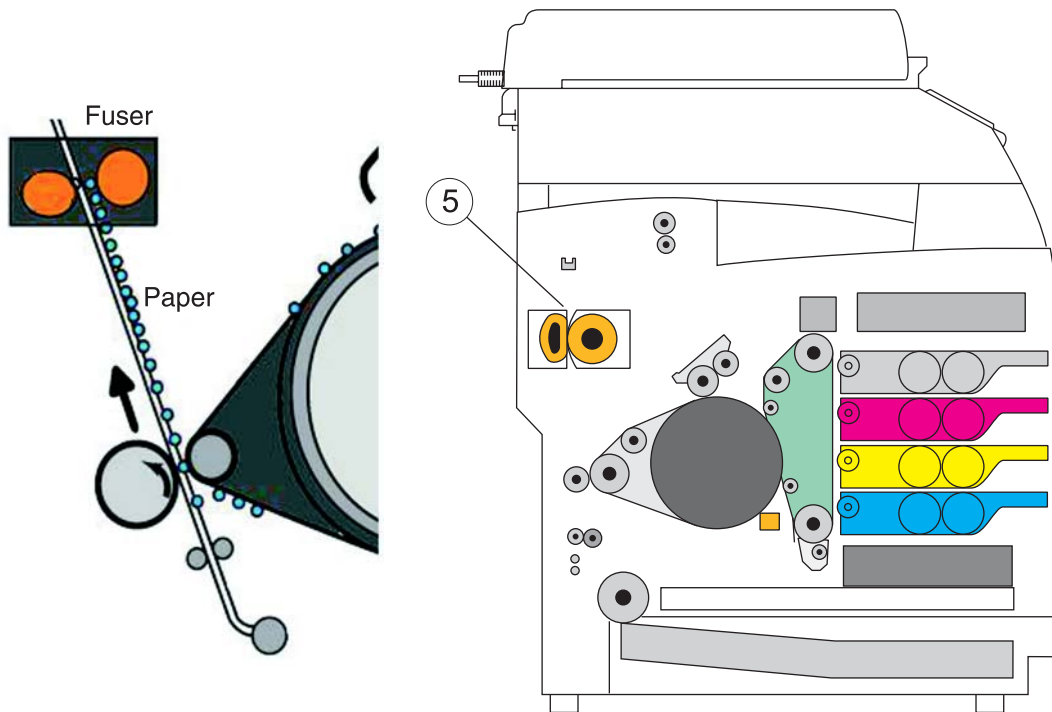

Note: If the fuser rollers are damaged, they can cause toner to be pulled off the page or cause paper jams.

Note: Toner that rubs off a printed page can be a sign of a malfunctioning fuser or an improper media setting. Always check the paper type setting on the printer and driver before replacing the fuser. A common mistake is to print on heavier media (such as card stock) with the paper type set to plain paper.

Note: When removing paper jams from the fuser, be sure to use the fuser release tabs to relieve the pressure on the page. In addition, never pull unfused toner through the fuser if you can help it; try to back the jammed page out of the fuser in the opposite direction it was traveling.

Step 6: Clean/Erase

There are two main cleaning processes that take place during the EP Process. One process cleans the photodeveloper and the other cleans the transfer unit.

Photodeveloper clean/erase

After each plane of color has been transferred to the transfer unit from the photodeveloper, a cleaning blade scrapes the remaining toner from the surface of the photodeveloper while an erase lamp discharges the remaining voltage. This is the clean/erase process.

The photodeveloper surface is prepared to begin the EP cycle once again. This cleaning/erasing cycle happens after each plane of color is transferred to the transfer unit.

Look at callout 6 in the picture below. This is where the photodeveloper is cleaned and erased in the photodeveloper phase of the clean/erase step of the EP process.

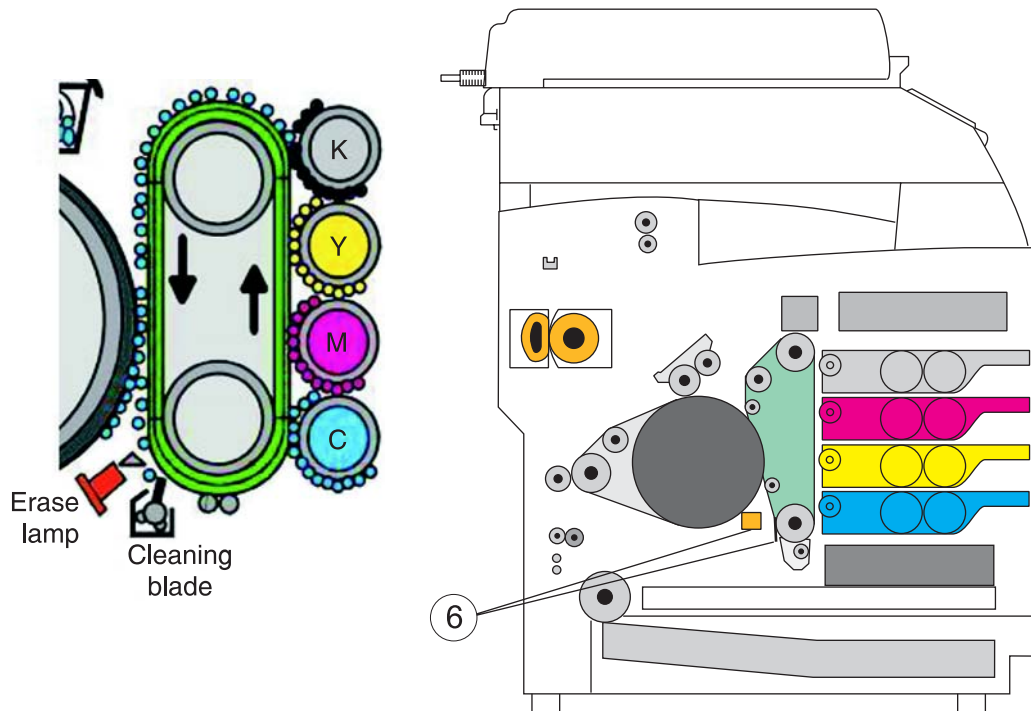

Transfer unit cleaning

Once the toner image on the transfer unit has been transferred to the page, the transfer unit rotates around and is cleaned by the cleaning roller. This cleaning happens after each page is printed.

A clutch engages a cam to lower the cleaning brush on the surface of the transfer unit and another clutch rotates the brush. The high voltage power supply sends a charge to the cleaning brush so the toner will want to stick to the cleaning brush instead of the transfer unit surface.

The waste toner is kicked into a containment area and moved by an auger system into the waste toner bottle. This is the transfer unit clean process.

Look at callout 6 in the picture below. This is the where the transfer unit is cleaned by the cleaning roller.

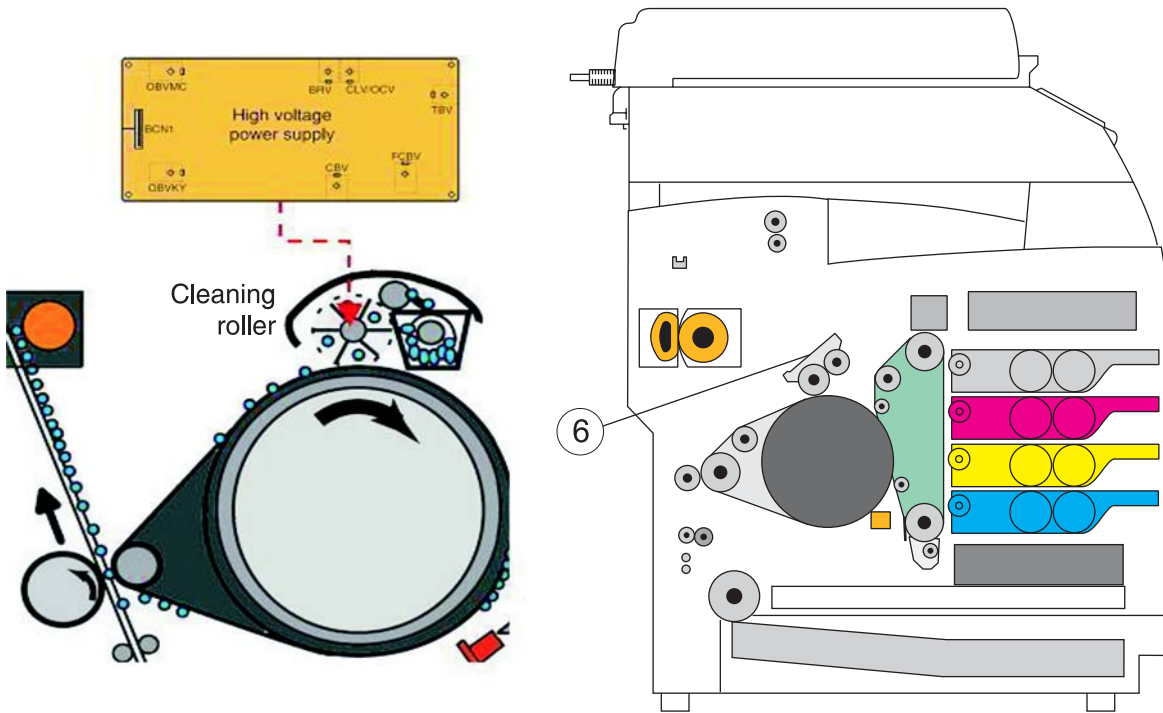

Note: If the cleaning roller is not positioned properly, it will not contact the transfer unit surface correctly. This results in waste toner remaining on the transfer unit and will cause residual images or “ghost” images. In other words, the remaining toner from one page will carry over to the next page as a light “ghosted” image on the printed page.

Printer Components

The following graphic illustrates all the EP and paper transport processes in the X500

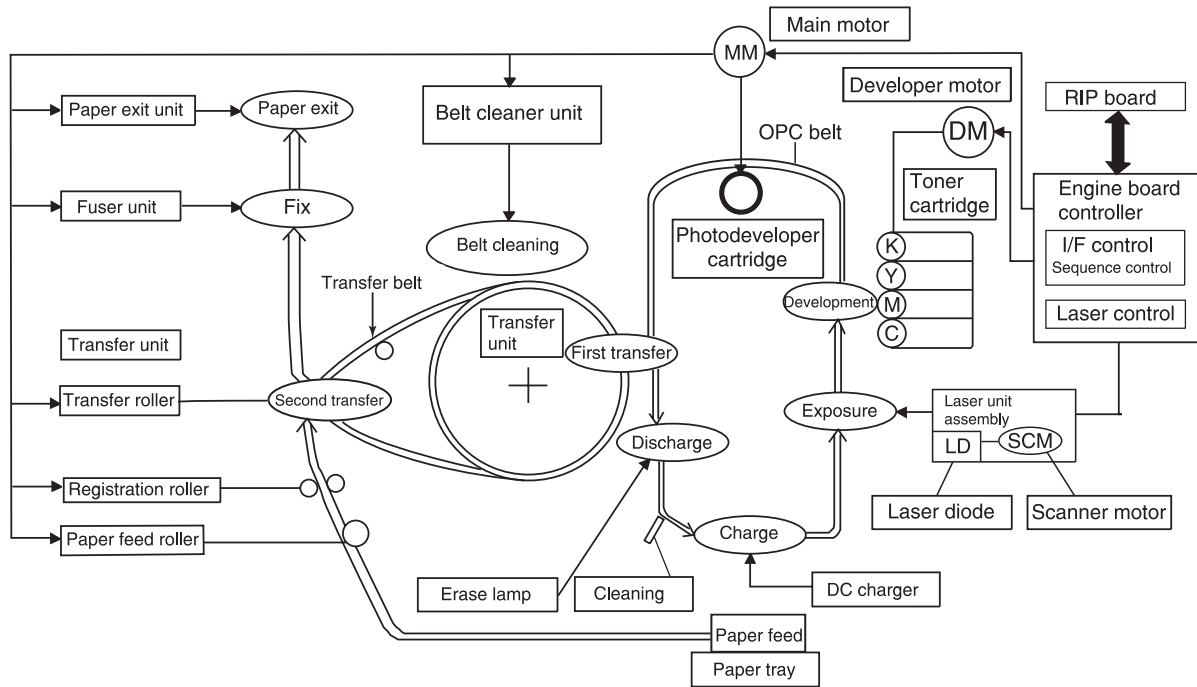

Paper path components

in order for an image to be printed, the media has to be moved from the paper tray to the printer and eventually exit into the output area.

The most important component in this process is this media itself. Old, damaged or out-of-specification media can and will cause feed and transport problems. If you encounter problems, you should always check the media first. See **“Media input types and weights” on page 1-8**. In addition, it is always good practice to check the printer and driver settings to see if the media being used matches the user’s settings in the driver. It is not uncommon to find a user printing on card stock with the printer programmed to print on a plain paper setting.

The printer feed and transport components can fail and cause paper jams or other feed and transport problems. These components should be examined for damage or wear and replaced if necessary.

X500n specific information

The Lexmark X500n has a simple “C” shaped paper path (see the picture below). The tray 1 paper path is shown in red, and the optional tray 2 path is shown in blue (Tray 2 is not shown).

Note: The tray 1 and tray 2 paper paths merge at the tray 1 paperfeed roll.

Paper is fed from the rear of the printer and travels upward through the rear cover.

There is no duplex option or finisher option on this printer. There is a 530-sheet drawer available (not shown).

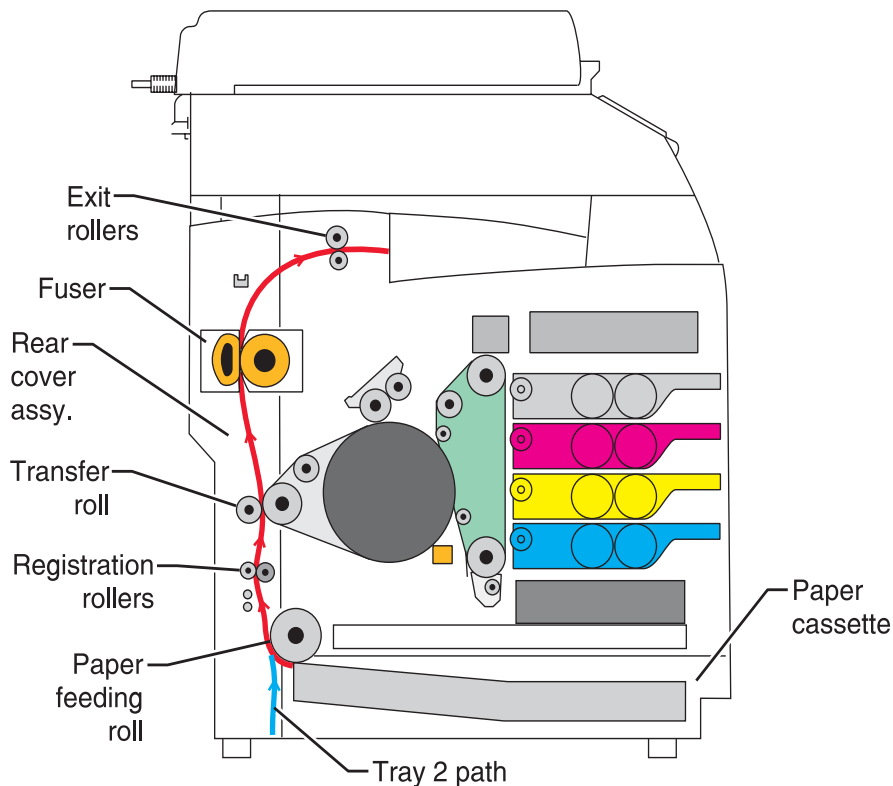

Transport Components

In summary, as shown in the previous illustration, the media is fed from the paper tray into the printer by a feed roller which carries the media to the registration rollers. The media trips the registration sensor. At this point, the media pauses so the registration rollers can properly time the media entry to the EP process. The registration rollers help ensure that the image is properly spaced and aligned on the media.

The registration rollers push the media to the transfer roller where the image is transferred to the page.

The transfer roller moves the media to the fuser. The fuser applies heat and pressure to the page. The heat and pressure permanently bond the image to the media. The fuser rollers push the media toward the exit bin and past the fuser exit sensor. The exit rollers guide the paper into the output bin.

Paper jam messages

The following illustration lists paper jam messages indicating where the paper jam occurred.

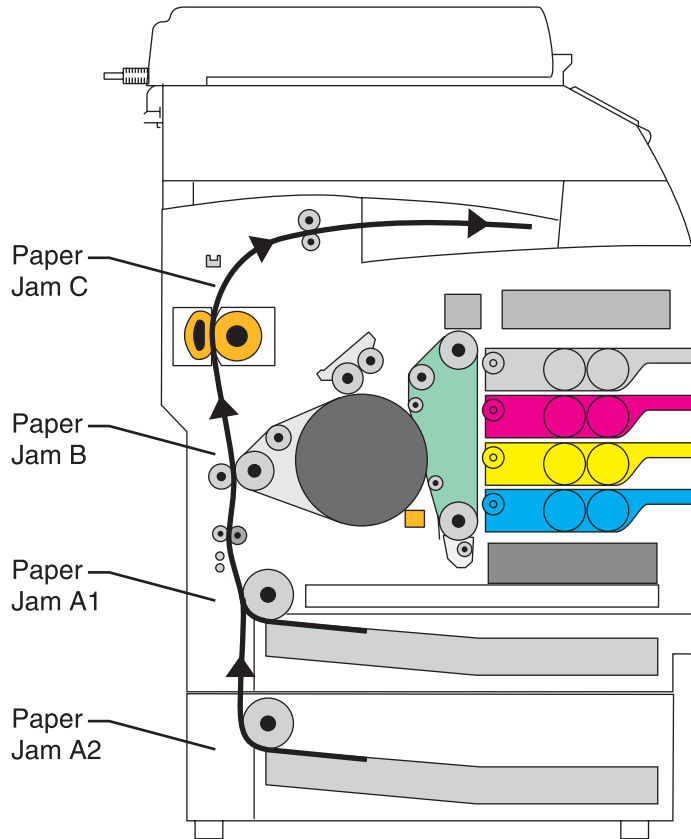

CAUTION

When clearing paper jams, inside of the printer may be hot. Allow printer to cool before touching any internal components.

Accessing jam areas

Open doors and covers, and remove trays to access jam areas. The illustration shows the location of sources and possible jam areas.

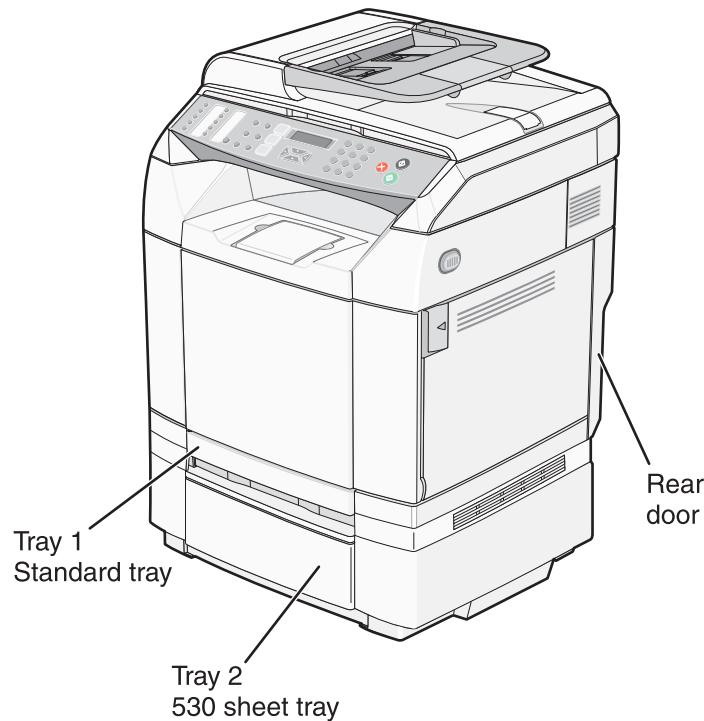

Use the following table to locate instructions for a particular jam; however, to resolve any message, you must clear all media from the media path.

Jam message	Go to page
Paper Jam A1, Rear (tray 1)	“Paper Jam A1, rear (tray 1)” on page 3-24.
Paper Jam A2, Rear (tray 2)	“Paper Jam A2, rear (tray 2)” on page 3-26.
Paper Jam B, Rear	“Paper Jam B rear” on page 3-27.
Paper Jam C, Rear	“Paper Jam C rear” on page 3-29.

Paper Jam A1, rear (tray 1)

A **PAPER JAM-A1** message indicates the media is jammed in tray 1. To clear a jam from the standard tray (Tray 1):

1. Pull the tray out. Remove the tray completely.
 - For a misfeed of the media, the single piece of media is laying on top of the stack. Pull it straight out.

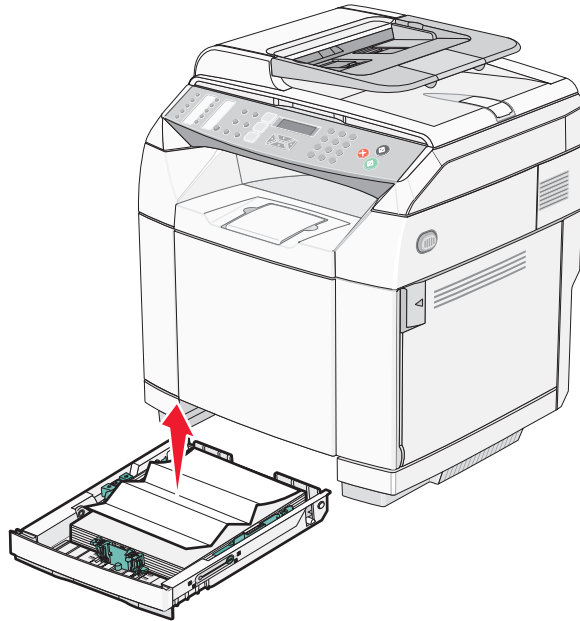

- For media jammed behind the tray area, locate the jam on the bottom surface of the tray housing. You may have to reach far under the printer to locate the jam, as shown in the following illustration. Pull the jam straight out.

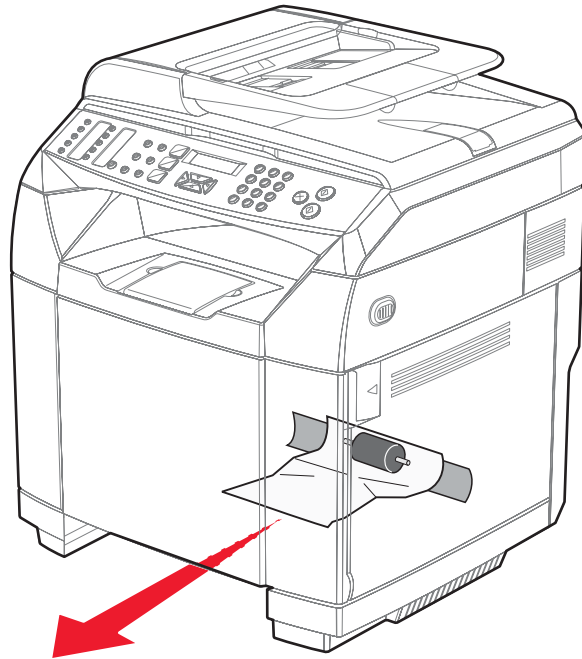

2. insert the tray.
3. If clearing paper doesn't resolve the problem, see **"Paper feed service checks" on page 2-44.**

Paper Jam A2, rear (tray 2)

A **PAPER JAM-A2** message indicates the media is jammed in tray 2. To clear a jam from the optional 530-sheet tray (Tray 2):

1. Pull the tray out. Remove the tray completely.
 - For a misfeed of the media, the single piece of media is laying on top of the stack. Pull it straight out.

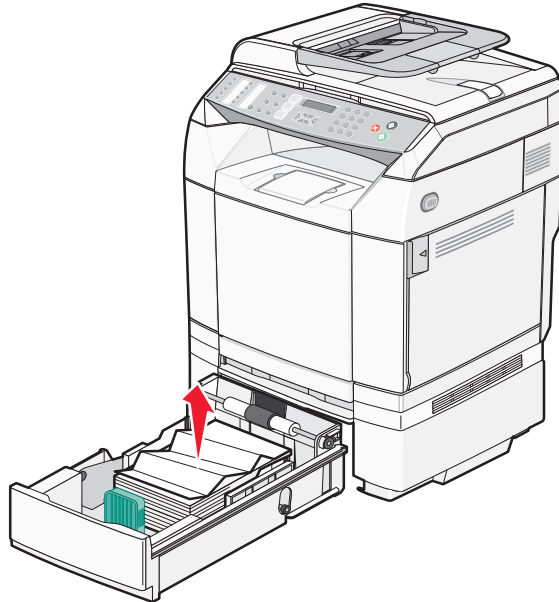

- For media jammed behind the tray area, locate the jam on the bottom surface of the support unit. You may have to reach far under the printer to locate the jam. Pull the jam straight out.

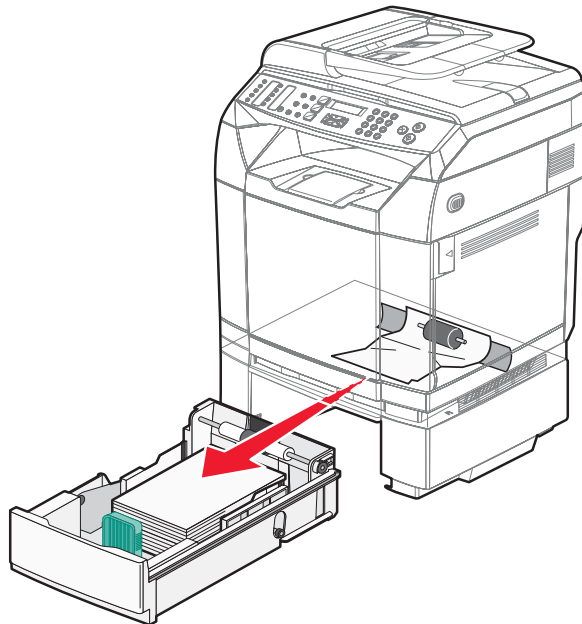

2. Push the tray into the support unit.
3. If clearing paper doesn't resolve the problem, replace the secondary paper feed assembly. See **"Secondary paper feed assembly removal"** on page 4-9.

Paper Jam B rear

	<p>CAUTION</p> <p>When clearing paper jams, inside of the printer may be hot. Allow printer to cool before touching any internal components.</p>
---	---

A **PAPER JAM-B** message indicates the media is jammed behind the rear door. To clear this type of jam, do the following:

1. Push the rear door release latch.

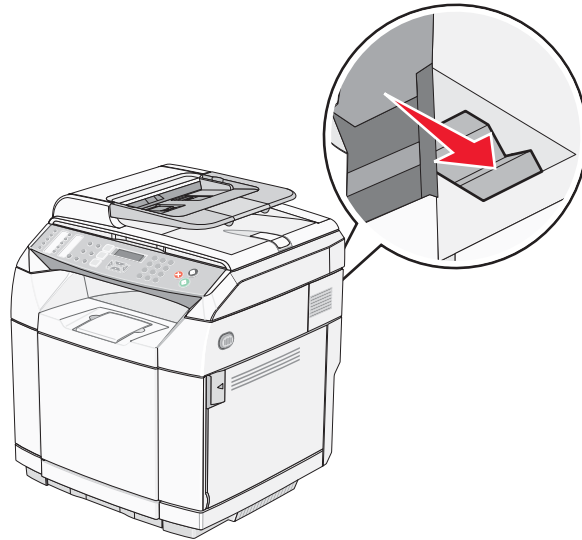

2. Gently lower the rear door.

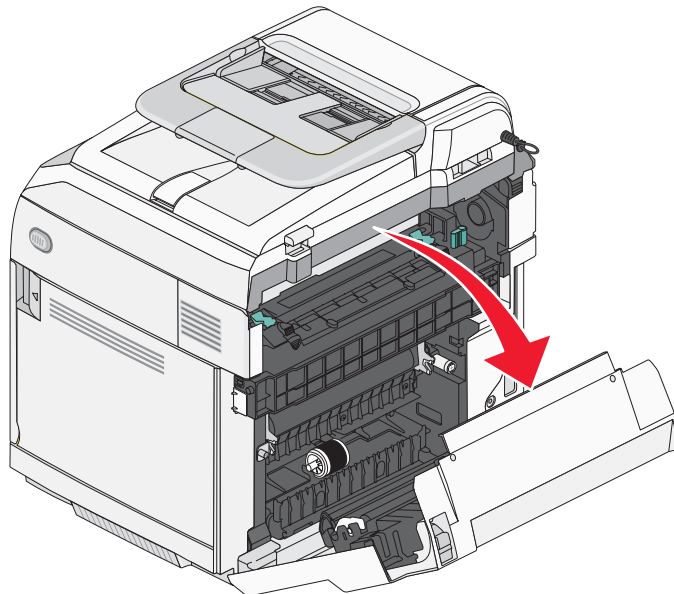

3. Pull the fuser pressure release levers to release tension on the media.
4. Grasp each side of the jammed media. Pull it to the rear of the printer and then out.

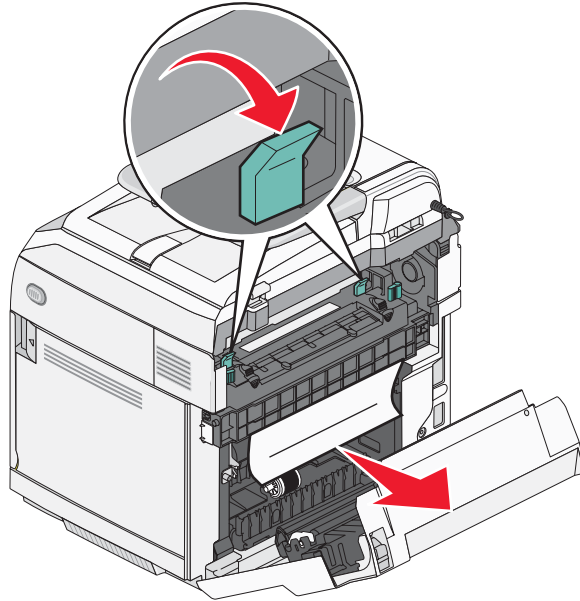

Note: Gently pull the media out so you do not tear it.

Note: If there is no media present in the fuser area, and print jobs appear smudged, see **“Smear service check” on page 2-58.**

5. Close the rear door.
6. Check registration sensor and its actuator. Replace if damaged. See **“Paper guide C assembly removal” on page 4-31.**
7. Ensure connector MCN9 on the engine controller board is connected. If connector is attached and error persists, replace the engine controller board. See **“Engine controller board removal” on page 4-34.**

Paper Jam C rear

A **PAPER JAM-C** message indicates the media is jammed behind the rear door above the fuser.

1. Push the rear door release latch, and gently lower the rear door.
2. Pull the fuser pressure release levers to release tension on the media.
3. Grasp each corner of the jammed media, and pull it up and out.

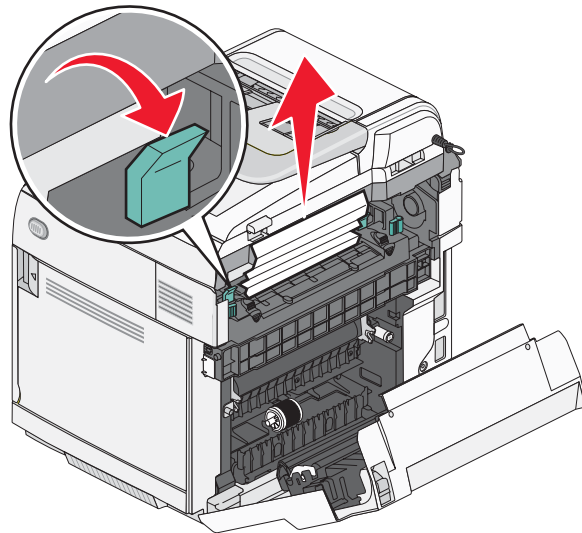

Note: Gently pull the media out so you do not tear it. Whenever possible, pull the media towards the bottom of the printer to avoid contamination of the fuser.

4. Close the rear door.
5. Check fuser exit sensor (located in the paper exit assembly) and its actuator. Replace if damaged. See **“Paper exit assembly removal” on page 4-32.**
6. Ensure connector MCN1 on the engine controller board is connected. If the connector is attached and the error persists, replace the engine controller board. See **“Engine controller board removal” on page 4-34.**

ADF paper jams

An **ADF JAM: Open ADF Cover and Clear Jam** message indicates a jam in the ADF.

WARNING: Do not clear any ADF jams until the release lever on the ADF pick roller assembly is opened.

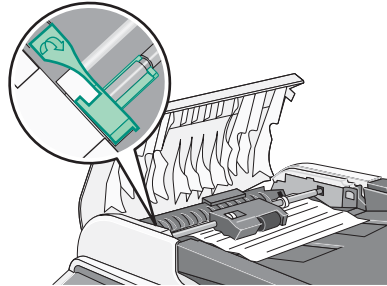

WARNING: Do not lift the flatbed lid and pull the jammed paper from the bottom of the ADF.



To clear an ADF paper jam, follow these steps.

1. Open the ADF top cover.

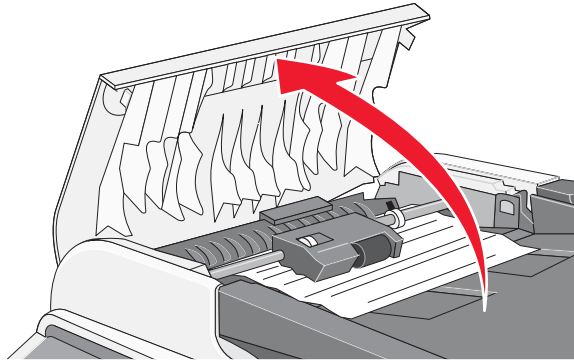

2. Lift the green separator roll release lever to the up position. Do not remove the separator roll.

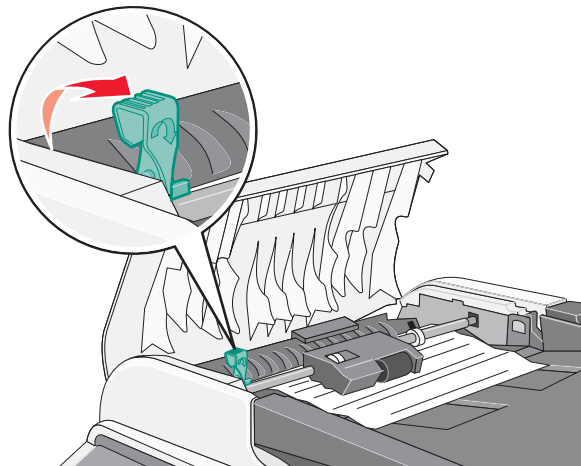

3. Pull the paper from the ADF assembly. Pull the paper in the direction of the ADF paper tray.

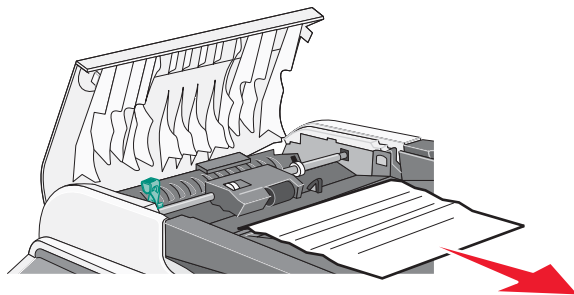

4. Lower the separator roller release lever until it locks in place.

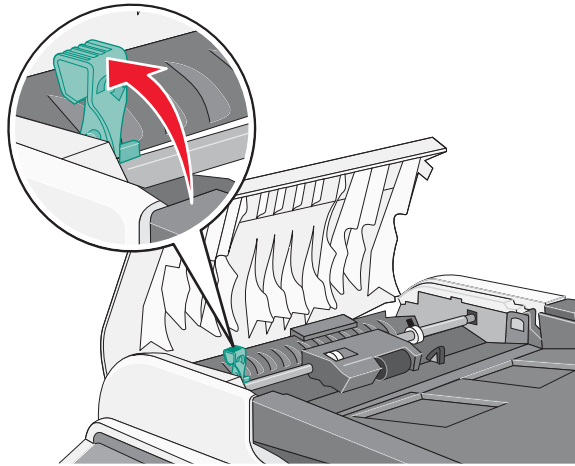

5. Close the ADF cover, and test the ADF.

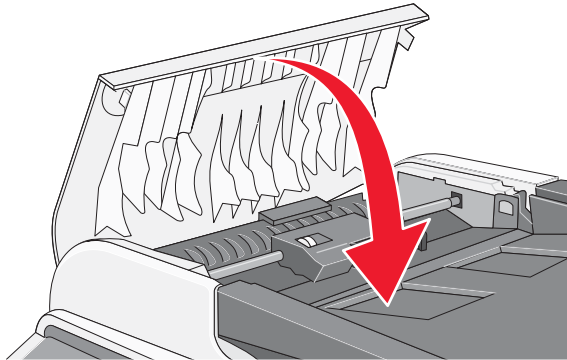

4. Repair information

Removal and cleaning precautions

Observe the following precautions whenever you service the MFP:

- Prior to starting any repair, read and understand the warnings in this manual.
- Be sure to unplug the MFP from the outlet before attempting to service the MFP.
- To reassemble the MFP, reverse the order of removal unless otherwise specified.
- Do not operate the MFP anytime during removals. If it is absolutely necessary to run the MFP with its covers removed, use care not to allow your clothing to be caught in revolving parts such as the gears, rollers and fan motor.
- Never touch the terminals of electrical parts or high-voltage parts such as the high voltage power supply.
- Remove the ground wire when removing or replacing the low voltage power supply. After installation is complete, confirm the ground wire is reconnected to the earth mark .
- After part replacement, ensure the wiring harness is not caught or damaged.
- Do not attempt to cut or extend the wiring harness.
- Confirm the wiring harness connector is connected properly.
- Be sure to handle the fuser carefully, as it remains hot for a while after the MFP stops running. Always unplug connectors by holding the connector housing.
- Remember to install the ground wire or ground plate to ensure a positive conduction. Install the screw with a toothed washer in the correct position at reassembly.
- Never lift the MFP from the scanner assembly.
- Confirm the direction of all parts and screw lengths during removal/replacement.
- Any part where the mounting screws are used to meet a machine alignment set at the factory must not be removed, disassembled, or adjusted. For example, the paper pickup roll mounting bracket or internal parts not provided as replacement parts.
- Utilize the proper cleaning procedures/solvents during maintenance.

Handling ESD-sensitive parts

Many electronic products use parts that are known to be sensitive to electrostatic discharge (ESD). To prevent damage to ESD-sensitive parts, follow the instructions below in addition to all the usual precautions, such as turning off power before removing logic cards:

- Keep the ESD-sensitive part in its original shipping container (a special “ESD bag”) until you are ready to install the part into the MFP.
- Make the least-possible movements with your body to prevent an increase of static electricity from clothing fibers, carpets, and furniture.
- Put the ESD wrist strap on your wrist. Connect the wrist band to the system ground point. This discharges any static electricity in your body to the MFP.
- Hold the ESD-sensitive part by its edge connector shroud (cover); do not touch its pins. If you are removing a pluggable module, use the correct tool.
- Do not place the ESD-sensitive part on the MFP cover or on a metal table; if you need to put down the ESD-sensitive part for any reason, first put it into its special bag.
- Machine covers and metal tables are electrical grounds. They increase the risk of damage, because they make a discharge path from your body through the ESD-sensitive part. (Large metal objects can be discharge paths without being grounded.)
- Prevent ESD-sensitive parts from being accidentally touched by other personnel. Install machine covers when you are not working on the machine, and do not put unprotected ESD-sensitive parts on a table.
- If possible, keep all ESD-sensitive parts in a grounded metal cabinet (case).
- Be extra careful in working with ESD-sensitive parts when cold-weather heating is used, because low humidity increases static electricity.

Photodeveloper cartridge

The following precautions must be observed when handling the photodeveloper cartridge or commonly called OPC (optical photo conductor). The photodeveloper cartridge is a supply item you will have to remove during some of the repair procedures:

During transportation/storage

Use the specified carton whenever moving or storing the photodeveloper cartridge.

Handling

- The OPC belt in the photodeveloper cartridge exhibits the greatest light fatigue after being exposed to strong light over an extended period of time. Never expose it to direct sunlight. Cover the photodeveloper cartridge when you remove it from the MFP.
- Use care not to contaminate the surface of the OPC belt with oil-base solvent, fingerprints, and other foreign matter.
- Do not scratch the surface of the OPC belt.

MFP removals

There are FRU/CRUs and supply items that will need to be removed prior to some of the removal procedures. The removal procedure will specify when the part must be removed.

Cleaning roller cover removal

1. Raise the scanner unit.
2. Open the top cover.
3. Depress the tabs, and remove the cleaning roller cover.



Transfer belt cleaning roller removal

1. Remove the cleaning roller cover. See **“Cleaning roller cover removal” on page 4-4.**
2. Lift and remove the transfer belt cleaning roller.



Transfer belt unit removal

1. Open the rear cover assembly.
2. Rotate the two captive screws (A) counterclockwise until they are loose.

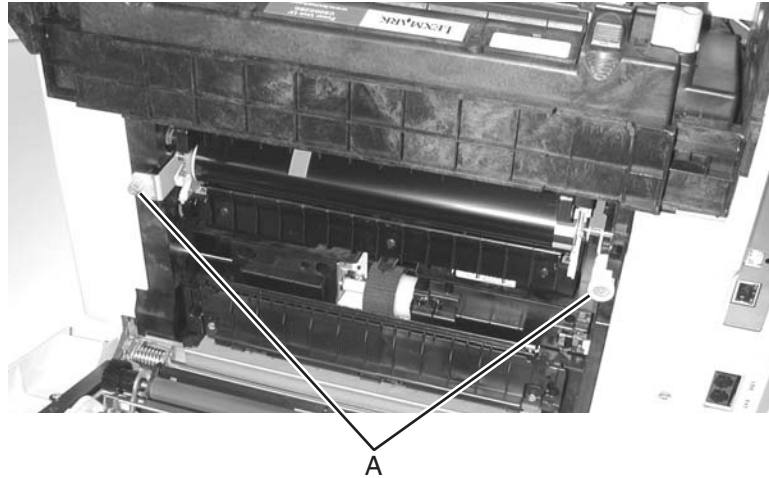

Warning: Take great care when removing the transfer belt unit to prevent scratching the transfer belt. Do not touch or hit the belt during removal.

3. Pull the transfer belt unit toward rear of the MFP, lift and remove.



Transfer roller removal

1. Open the rear cover assembly.
2. Rotate the transfer roller to release; lift and remove.



Fuser assembly removal

1. Push the rear cover assembly latch, and lower the rear cover assembly.
2. Turn two green fuser release levers (A).

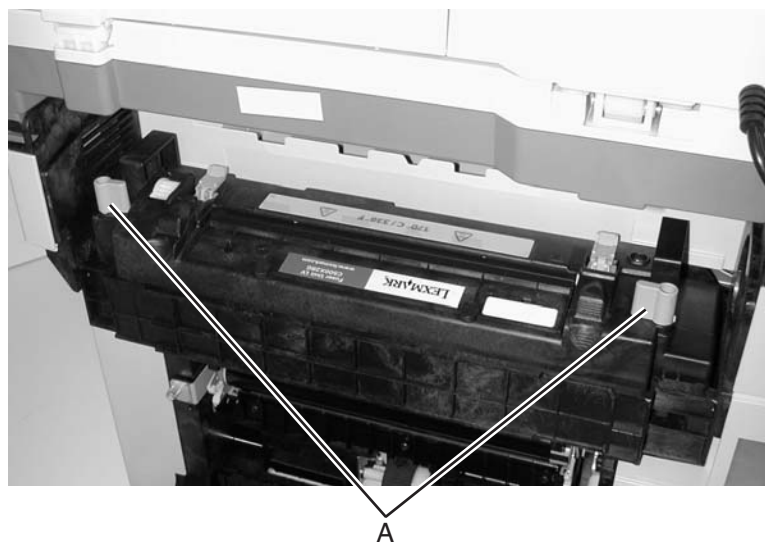

3. Lift the fuser straight up and away from the MFP.



Waste toner bottle removal

1. Open the front cover.
2. Remove the waste toner bottle.



Warning: Ensure that the waste toner bottle is secured and not allowed to tip over during repair process. Failure to adhere to this warning may result in toner spillage.

Photodeveloper cartridge removal

Warning: Follow precautionary procedures (see **“Photodeveloper cartridge” on page 4-3**) when removing the photodeveloper cartridge.

1. Raise the scanner assembly.
2. Open the top cover assembly.
3. Depress the release levers (A).
4. Lift and remove the photodeveloper cartridge.

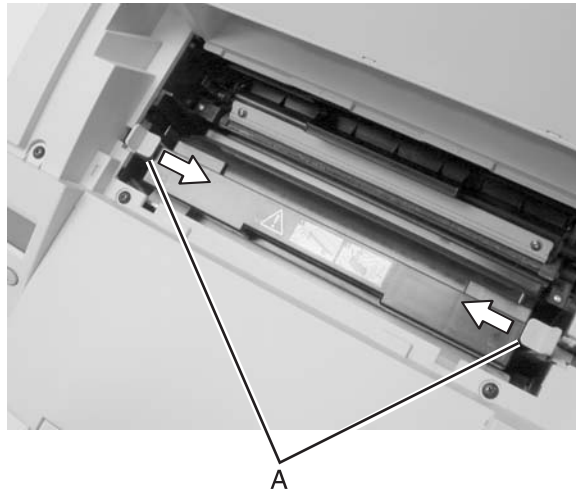

5. Lay the photodeveloper cartridge as shown in a clean area.



6. Cover the photodeveloper cartridge with a piece of paper as shown.

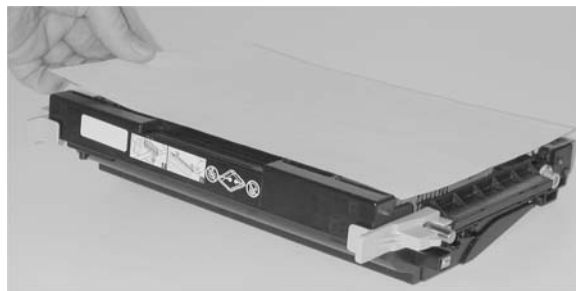

Secondary paper feed assembly removal

1. Remove the left secondary paper feed assembly cover. Repeat for the right side.



2. Loosen the thumbscrew (A) on the left bracket, and remove the bracket. Repeat for the right side.

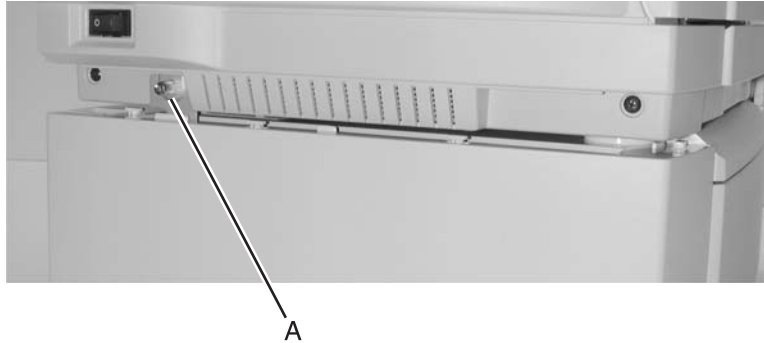

3. With help from another person, lift the MFP by the recessed handholds and remove the MFP from the secondary paper feed assembly.

Cover removals

Top cover assembly removal

1. Remove the scanner assembly. See **“Flatbed assembly removal”** on page 4-50.
2. Remove the upper right rear cover. See **“Upper right rear cover removal”** on page 4-17.
3. Remove the cleaning roller cover. See **“Cleaning roller cover removal”** on page 4-4.
4. Remove the photodeveloper cartridge. See **“Photodeveloper cartridge removal”** on page 4-8.
5. Open the OPC cover.
6. Remove the two screws (A) from the top cover assembly.

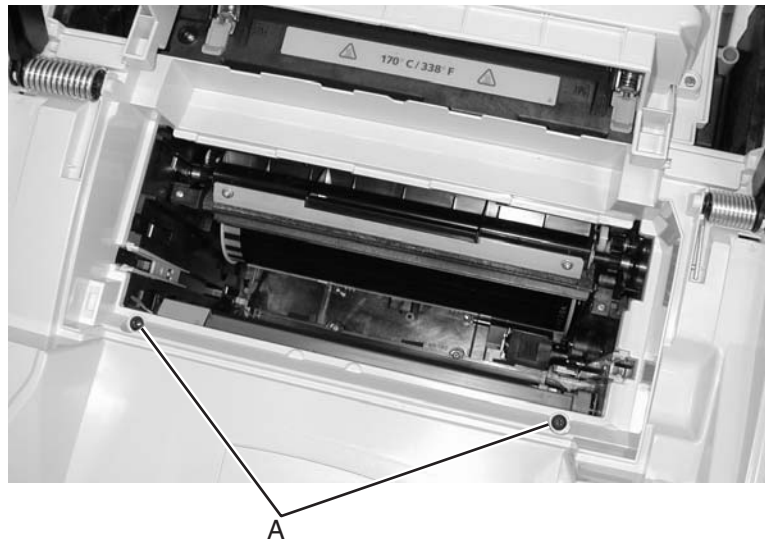

7. Open the rear cover.
8. Remove the upper right rear cover. See **“Upper right rear cover removal”** on page 4-17.

9. Remove the screw (B) which secures the top cover to the MFP frame.

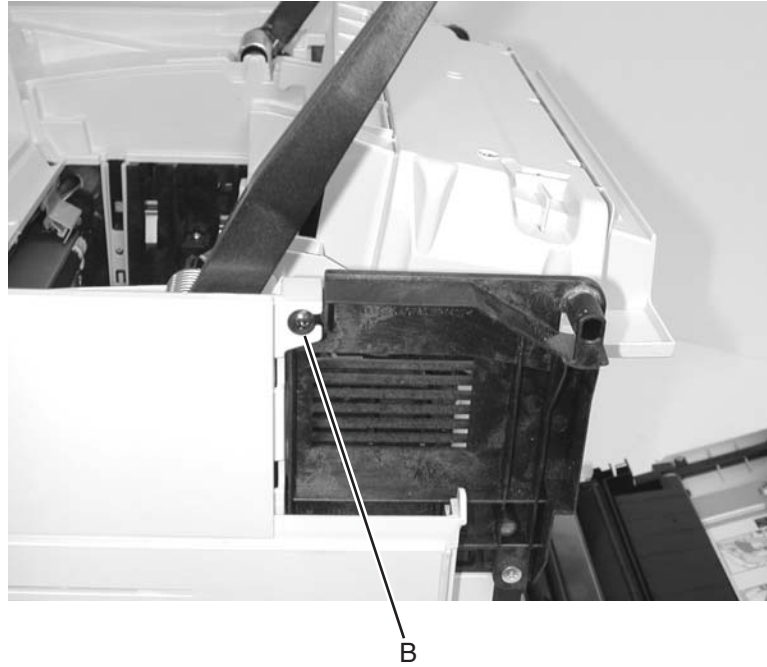

10. Remove the upper left rear cover. See **“Upper left rear cover removal”** on page 4-17.
11. Remove the screw (C) which secures the top cover to the MFP frame.



12. Release the tabs on the front of the top cover assembly.
13. Lift the top cover assembly and remove.

Note: If you are replacing the top cover assembly, remove the scanner arms. They will be used on the new top cover. See **“Scanner arm removal”** on page 4-53.

Front cover assembly removal

1. Open the front cover assembly.
2. Remove the 8 screws (A) from the inner front cover.

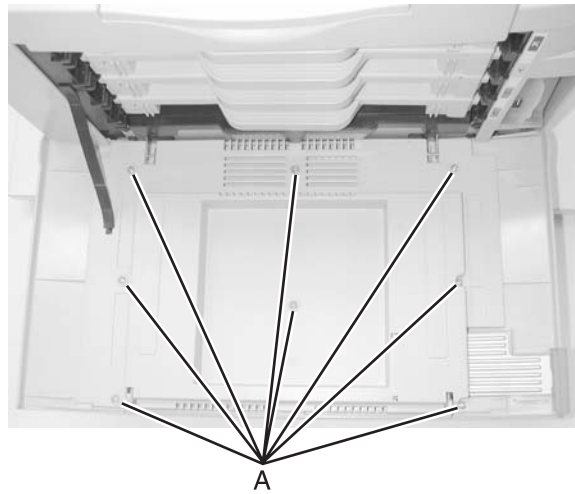

3. Disengage the support strap from the MFP.

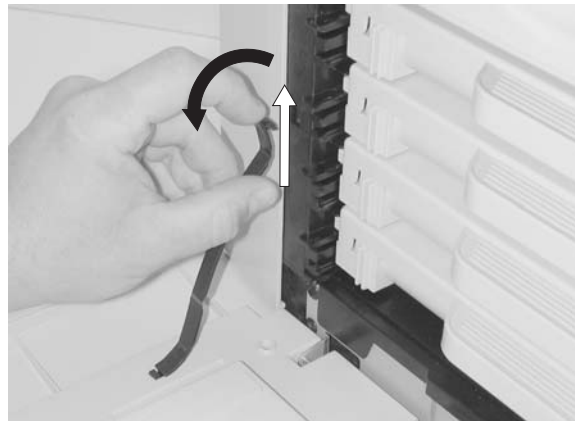

4. Release the tabs on the front cover.



5. Remove the front cover from the inner front cover.
6. Raise the inner front cover.

7. Rotate the support pin away from the MFP, and slide toward the center of the MFP to remove. Repeat for the other support pin



8. Remove the front inner cover from the MFP.

Right cover removal

1. Remove the waste toner bottle. See **“Waste toner bottle removal”** on page 4-7.
2. Remove the top cover assembly. See **“Top cover assembly removal”** on page 4-10.
3. Remove 2 screws (A) from the bottom of the right cover.

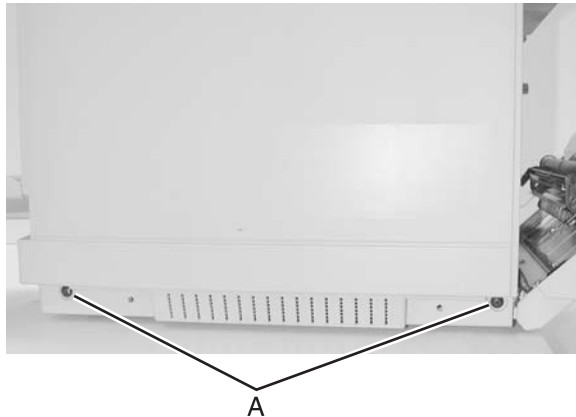

4. Remove the right cover from the MFP. Maneuver the front cover for easy removal.

Rear cover assembly removal

1. Remove the fuser assembly. See **“Fuser assembly removal”** on page 4-6.
2. Remove the transfer belt unit. See **“Transfer belt unit removal”** on page 4-5.
3. Remove the right cover. See **“Right cover removal”** on page 4-13.
4. Disconnect the rear cover assembly connector (A).
5. Remove the support pin (B), disconnecting the support cable from the MFP.
6. Remove two screws (C) from the rear cover assembly.

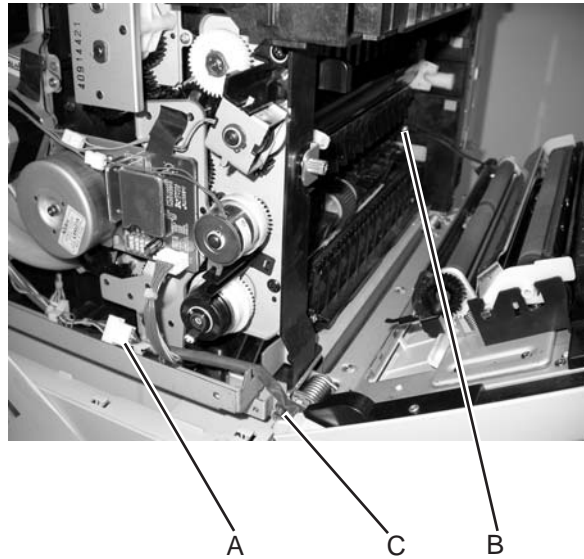

7. Slide the right side of the rear cover assembly away from the MFP until the hinge clears the slot.

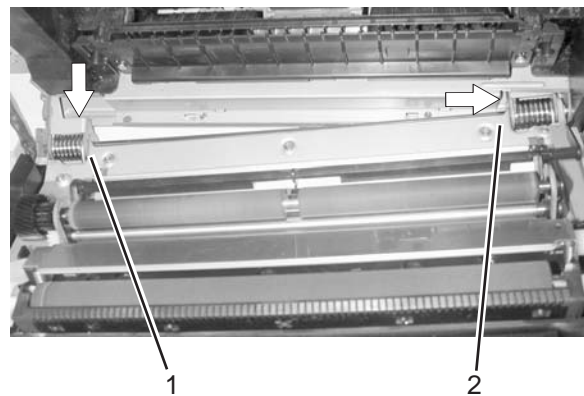

8. Slide the rear cover assembly toward the right side until the captured end of the rear cover assembly clears the mounting bracket.
9. Remove the rear cover assembly by pulling it away from the MFP.

Left front cover removal



1. Remove the top cover assembly. See **“Top cover assembly removal”** on page 4-10.
2. Remove two screws (A) from the bottom of the left front cover.



3. Remove the left cover from the MFP.

Left rear cover removal

1. Remove the screw (A) that secures the left rear cover to frame.

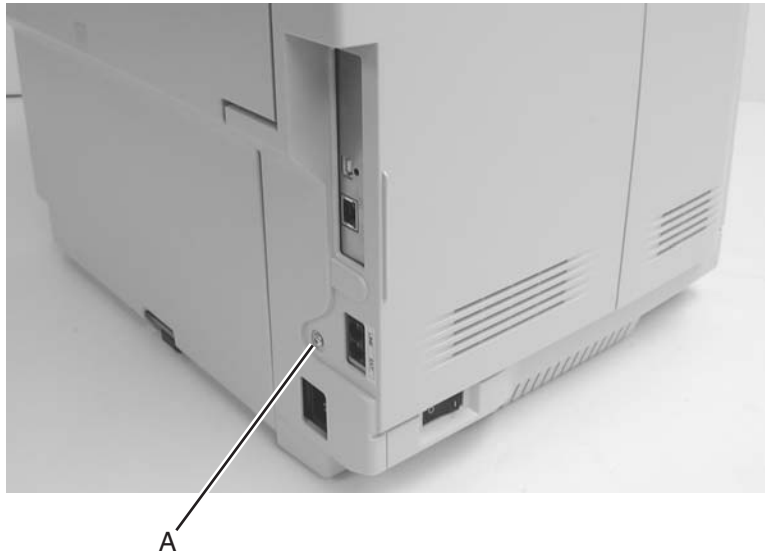

2. Slide the left rear cover back, and remove it from the printer.

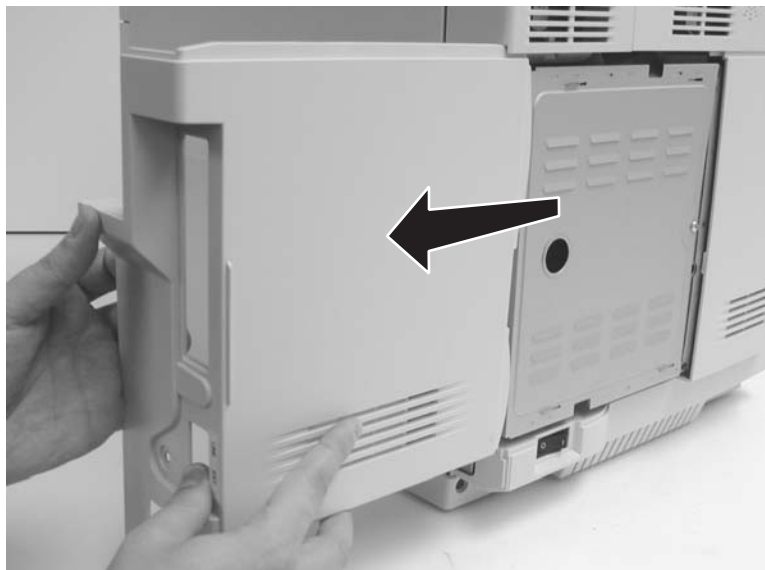

Upper right rear cover removal

1. Open the rear cover. See **“Rear cover assembly removal” on page 4-14.**
2. Remove the screw (A) that secures the upper right rear cover to the frame.



3. Remove the upper right rear cover.

Upper left rear cover removal

1. Remove the left rear cover. See **“Rear cover assembly removal” on page 4-14.**
2. Remove the screw (A) that secures the upper left rear cover to the frame.



3. Remove the upper left rear cover.

Laser unit assembly (printhead) removal

1. Open the front cover.
2. Remove the toner cartridges.
3. Remove the photodeveloper cartridge. See **“Photodeveloper cartridge removal” on page 4-8.**
4. Open the top cover assembly.
5. Remove the two screws (A) from the laser unit assembly cover. The photograph below is looking through the opening in the top cover assembly.

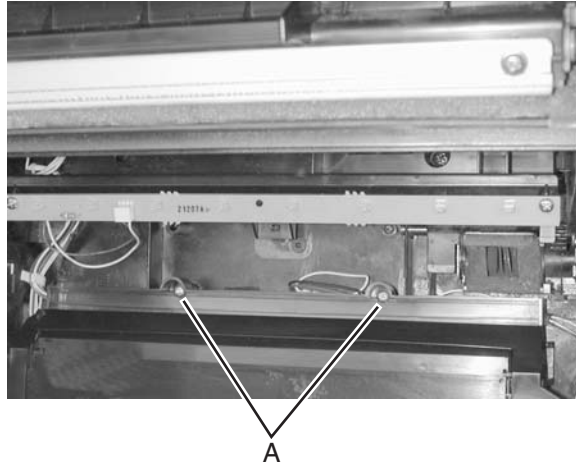

6. Unlatch and remove the laser unit assembly cover.



7. Remove four screws (B) from the laser unit assembly.

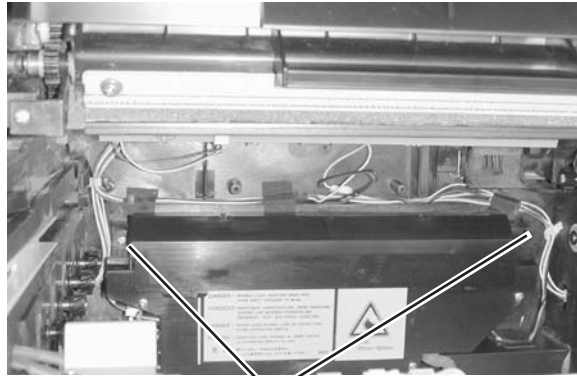

B

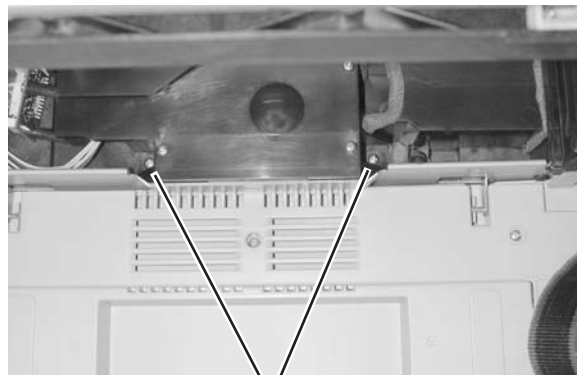

B

8. Remove the laser unit assembly from the MFP.
9. Disconnect the connector from the laser unit assembly.

Erase lamp removal

1. Remove all the toner cartridges.
2. Remove the photodeveloper cartridge. See **“Photodeveloper cartridge removal” on page 4-8.**
3. Remove the transfer belt unit. See **“Transfer belt unit removal” on page 4-5.**
4. Remove the two screws (A).

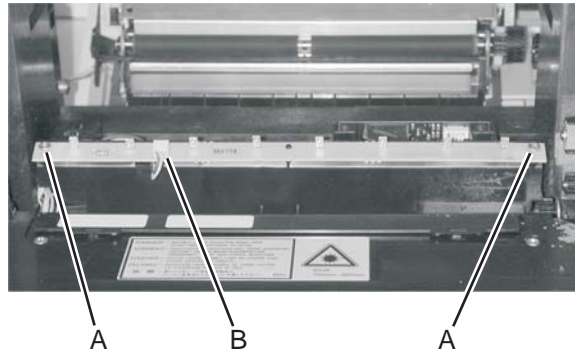

5. Disconnect the erase lamp cable (B).
6. Remove the erase lamp.

Right side removals

Front door interlock switch with bracket

1. Remove the top cover assembly. See **“Top cover assembly removal”** on page 4-10.
2. Remove the right cover. See **“Right cover removal”** on page 4-13.
3. Disconnect the interlock switch cable (A) from the interlock switch.

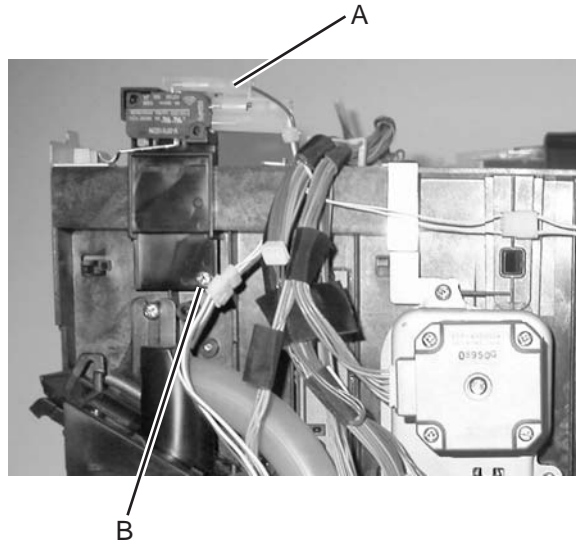

4. Remove the screw (B) and disengage the locking clip on the back of the bracket.
5. Remove the switch with the bracket.

Waste toner bottle holder removal

1. Remove the right cover. See **“Right cover removal”** on page 4-13.
2. Disconnect the waste toner bottle holder connector (A).

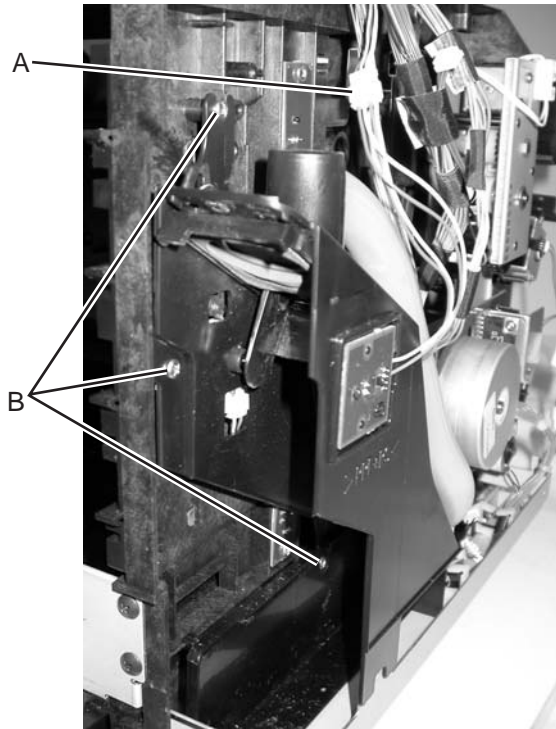

3. Remove three screws (B) from the waste toner bottle holder. The bottom screw is longer than the other screws.
4. Remove the waste toner bottle holder from the MFP.

Developer drive assembly removal

1. Remove the main motor assembly. See **“Main motor assembly removal”** on page 4-26.
2. Remove the waste toner bottle holder. See **“Waste toner bottle holder removal”** on page 4-22.
3. Remove four clips and the developer drive gears (A) from the inside of the MFP.

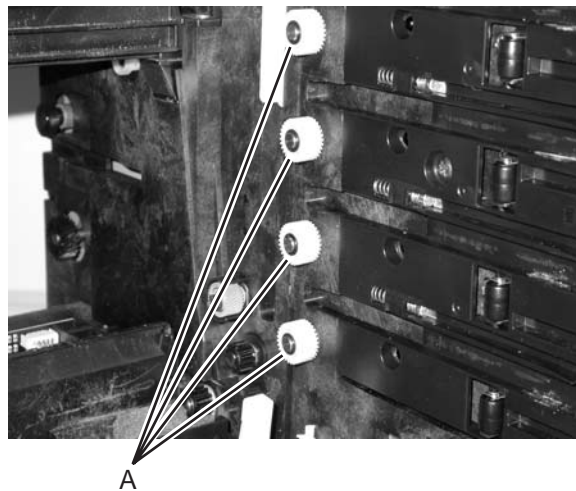

4. Disconnect the developer driver assembly cables (B).

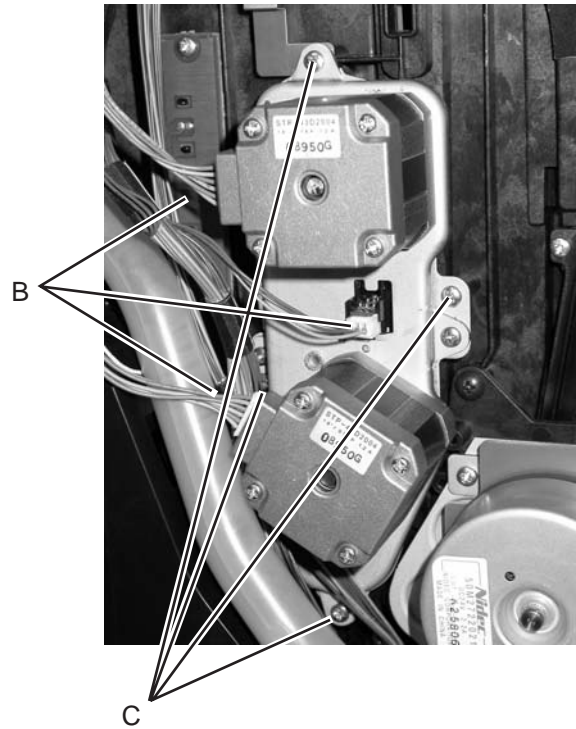

5. Remove the four screws (C) from the developer drive assembly.
6. Remove the developer drive assembly from the MFP.

Toner sensor (sender) removal

1. Remove the developer drive assembly. See **“Developer drive assembly removal”** on page 4-22.
2. Remove two screws (A) from the toner sensor.

Note: The bottom screw is longer than the top screw.

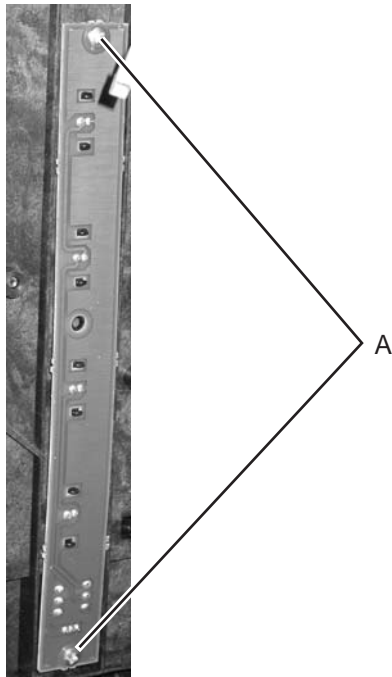

3. Pull the toner sensor away from the MFP, disconnect the cable, and remove the sensor.

Cleaning roller clutch removal

1. Remove the transfer belt cleaning roller. See **“Transfer belt cleaning roller removal”** on page 4-4.
2. Remove the right cover. See **“Right cover removal”** on page 4-13.
3. Using a flat-tipped tool, pry and remove the cleaning roller clutch gear from the inside of the MFP.

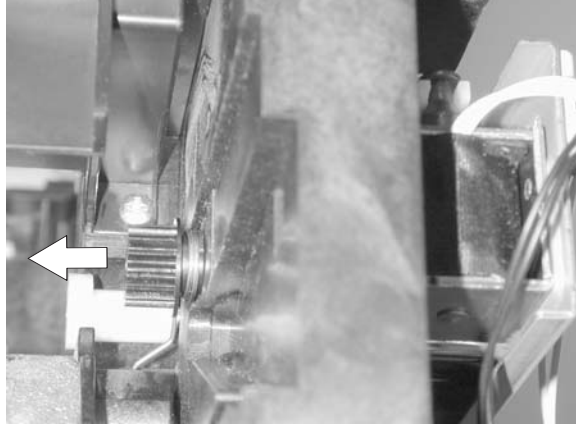

4. Disconnect the cleaning roller clutch cable (A).
5. Remove three screws (B) from the cleaning roller clutch.

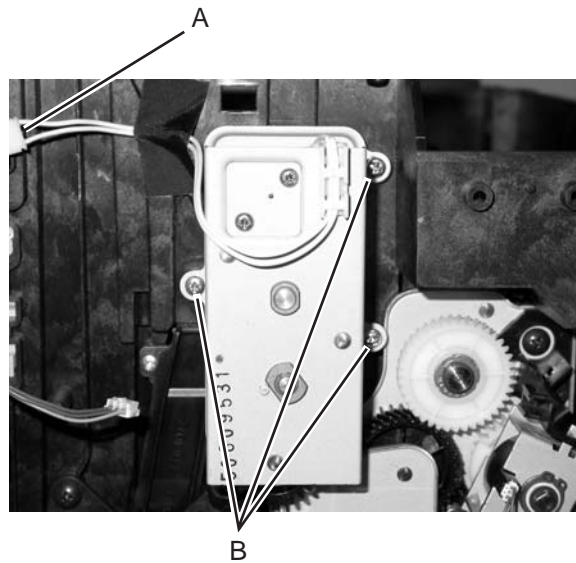

6. Remove the cleaning roller clutch from the MFP.

Main motor assembly removal

1. Remove the right cover. See **“Right cover removal”** on page 4-13.
2. Disconnect the main motor assembly cable (A) from the main motor.
3. Remove 4 screws (B) from the main motor assembly.

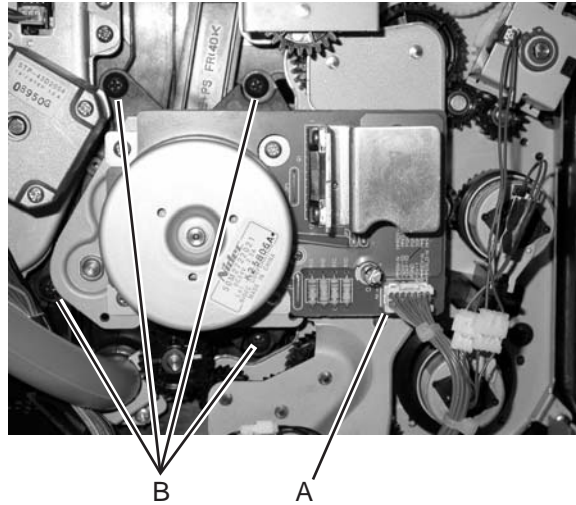

4. Remove the main motor assembly from the MFP.

Clutch removal

Note: This procedure applies to the transfer roller clutch, registration clutch, and the paper feed clutch. The transfer clutch removal is shown. This removal is typical for the others.

1. Remove the right cover. See **“Right cover removal” on page 4-13.**
2. Disconnect the clutch cable (A).
3. Remove the clip (B) from the clutch.

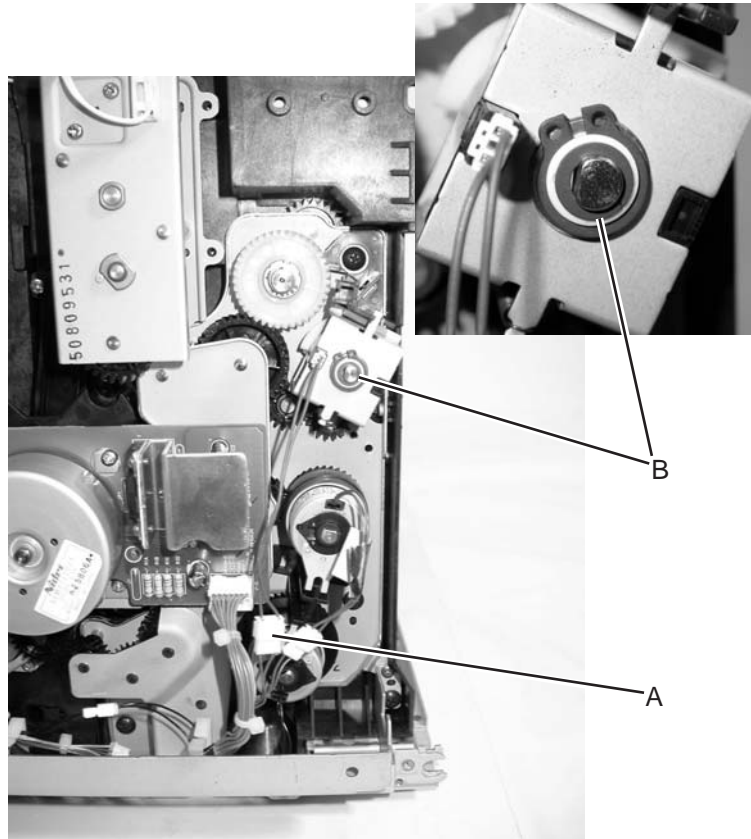

4. Slide the clutch away from the MFP to remove.

Main drive gear assembly removal

1. Remove the cleaning roller clutch. See **“Toner sensor (sender) removal” on page 4-24.**
2. Remove the main motor assembly. See **“Main motor assembly removal” on page 4-26.**

Note: If you are removing the main drive gear assembly to get to the waste toner feeder, you do not have to remove the fuser, transfer roller, registration, or paper feed clutch. The clutches are removed at the beginning of this procedure, because the main drive gear assembly FRU does not include the clutches.

3. Remove the transfer roller clutch. See **“Clutch removal” on page 4-27.**
4. Remove the registration clutch. See **“Clutch removal” on page 4-27.**
5. Remove the paper feed clutch. See **“Clutch removal” on page 4-27.**

6. Remove five screws (A) that secure the main drive gear assembly to the MFP.

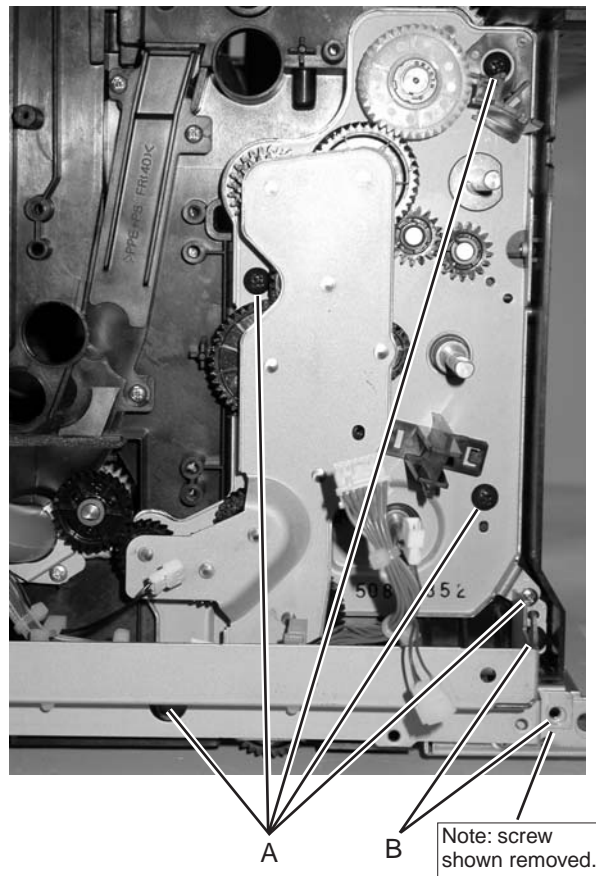

7. Remove two screws (B) that secure the lower right frame.
8. Remove the main drive gear assembly from the MFP.

Note: When reinserting the main drive gear assembly, ensure that the bottom right corner is installed before the lower right frame.

Waste toner feeder removal

1. Remove the main drive gear assembly. See **“Main drive gear assembly removal”** on page 4-27.
2. Loosen the two screws (A) of the sensor base to allow free movement of the waste toner feeder.

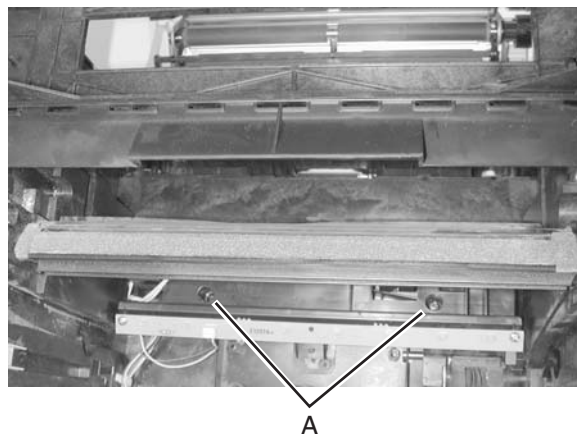

3. Remove screw (B) from the waste toner feeder pipe.

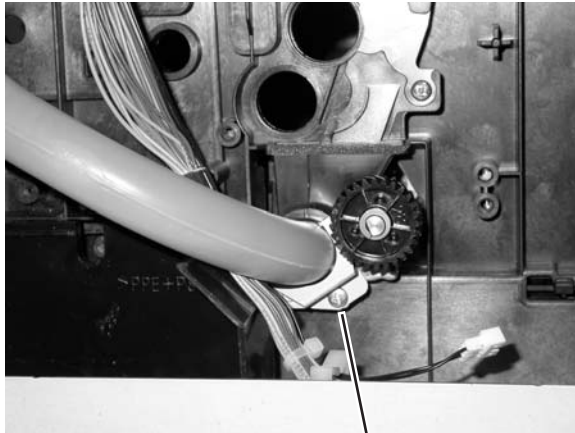

B

4. Remove the waste toner feeder pipe from the waste toner bottle holder.
5. Pull and remove the waste toner feeder from the MFP.

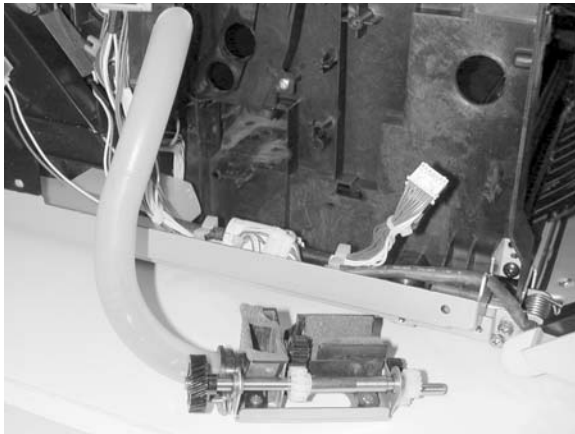

Rear removals

Bracket assembly removal

1. Remove the erase lamp. See **“Erase lamp removal”** on page 4-20.
2. Remove two screws (A).
3. Disconnect connector (B) from the transfer belt marker sensor.
4. Disconnect connector (C) from the toner density sensor.

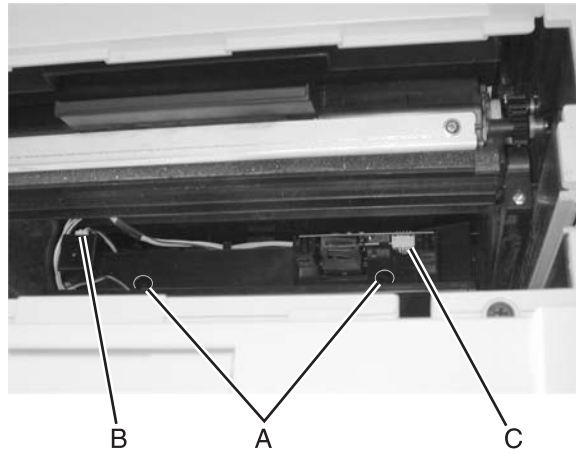

5. Lift and remove the bracket assembly.

Paper guide assembly removal

1. Remove the registration assembly. See **“Registration assembly removal”** on page 4-33.
2. Remove two screws (A) that attach the paper guide assembly to the MFP. Screws are located in holes.
3. Lift and remove the paper guide assembly (B) from the MFP.

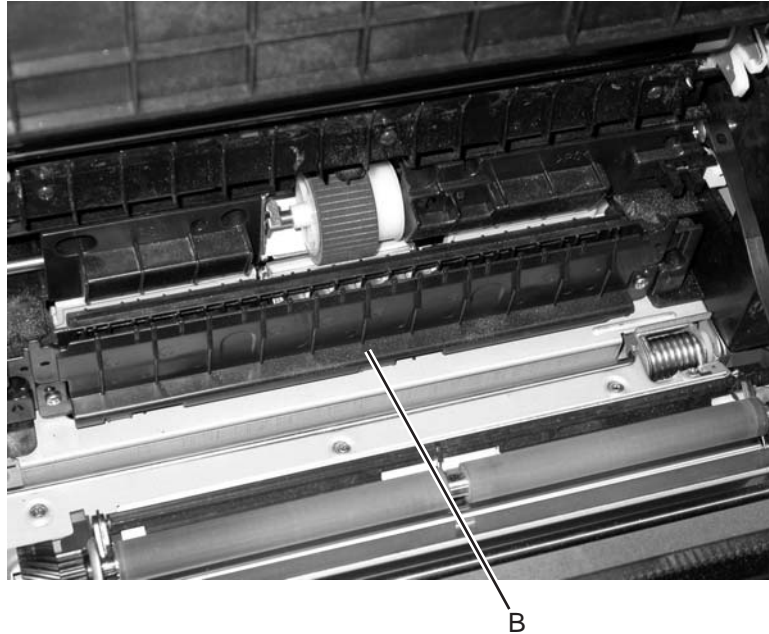

Paper guide C assembly removal

1. Remove the paper guide assembly. See **“Paper guide assembly removal”** on page 4-31.
2. Remove the transfer belt unit. See **“Transfer belt unit removal”** on page 4-5.
3. Remove the support pin, disconnecting the support cable (A) from the MFP.
4. Remove the two screws (B) that attach the paper guide C assembly to the MFP.

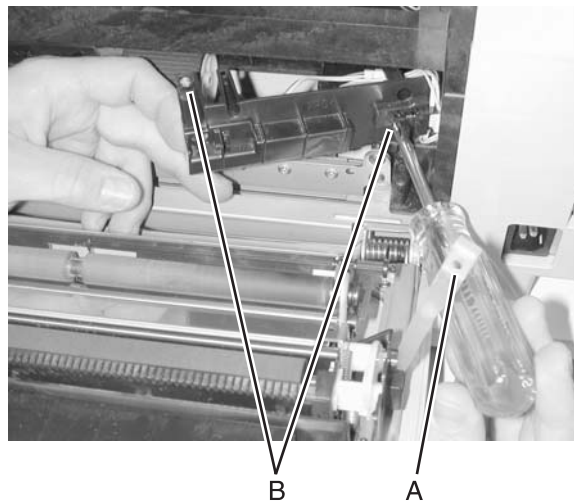

5. Disconnect two sensor cables from the sensors located on the paper guide C assembly, and remove the paper guide C assembly.

Paper feed roller removal

1. Remove the paper guide C assembly. See **“Paper guide C assembly removal”** on page 4-31.
2. Slide the paper feed roller off the shaft to remove.



Paper exit assembly removal

1. Remove two screws (A).

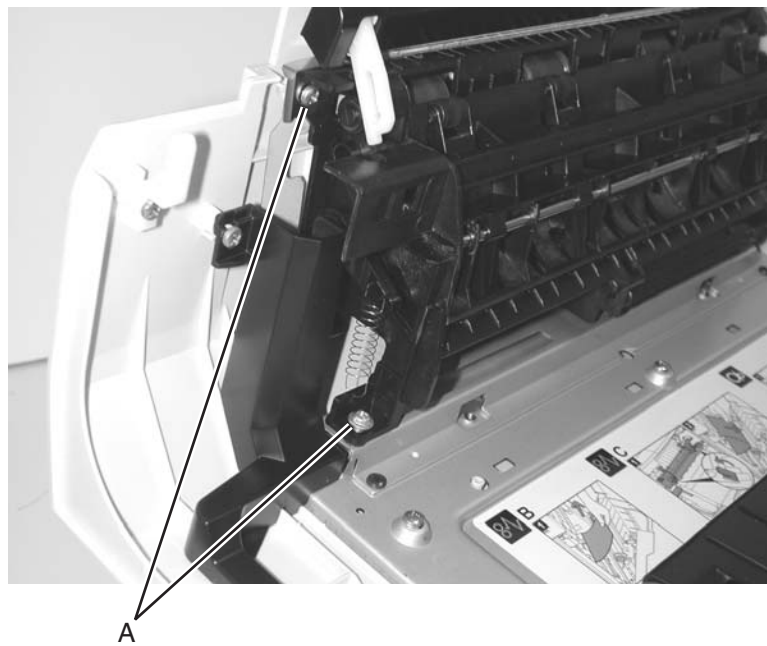

2. Disconnect the cable (B).
3. Remove two screws (C).

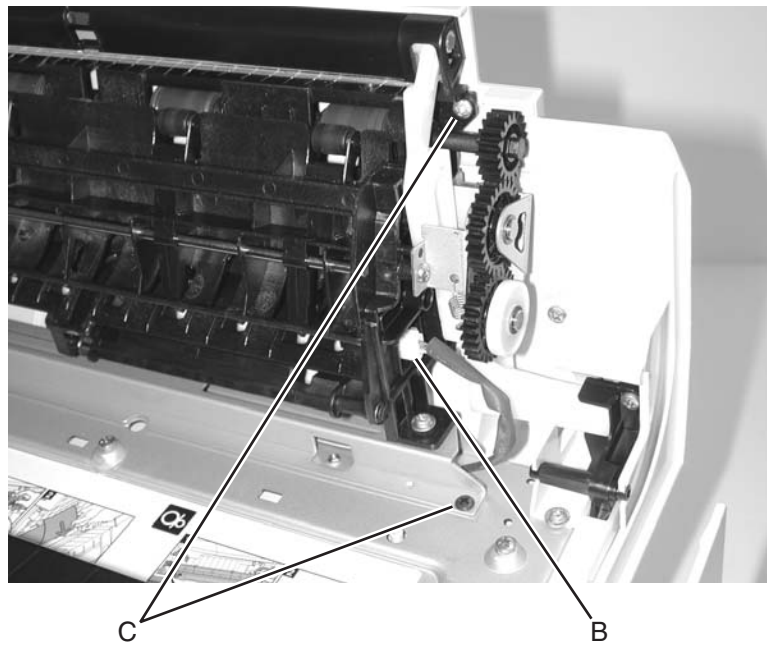

Registration assembly removal

1. Remove the transfer roller. See **“Transfer roller removal”** on page 4-6.
2. Remove three metal screws (A) and three plastic screws (B).

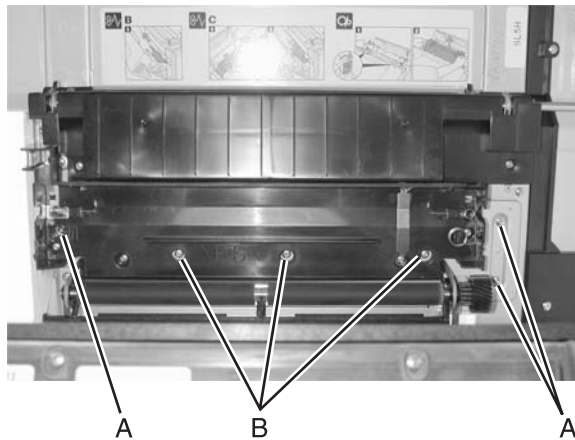

3. Lift and remove the registration assembly.

Left side removals



Engine controller board removal

Warning: Before replacing the engine controller board, save the onboard settings. See **“Printing the maintenance and configuration pages”** on page 3-3.

1. Remove the left front cover. See **“Left front cover removal”** on page 4-15.
2. Remove the system board. See **“System board removal”** on page 4-36.
3. Remove three screws (A) from the engine controller board shield; remove the shield.

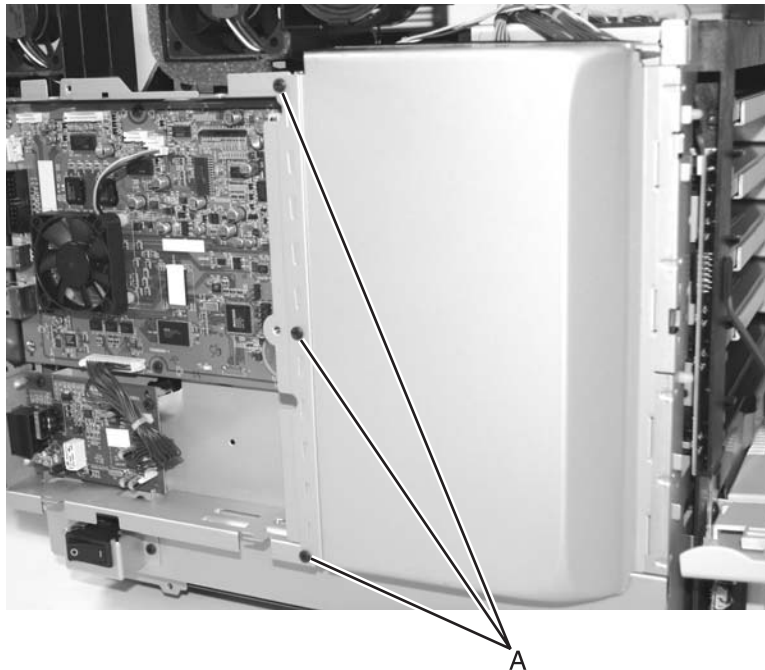

4. Disconnect all the connectors from the engine controller board.



5. Remove five screws (B) from the engine controller board; remove the engine controller board.

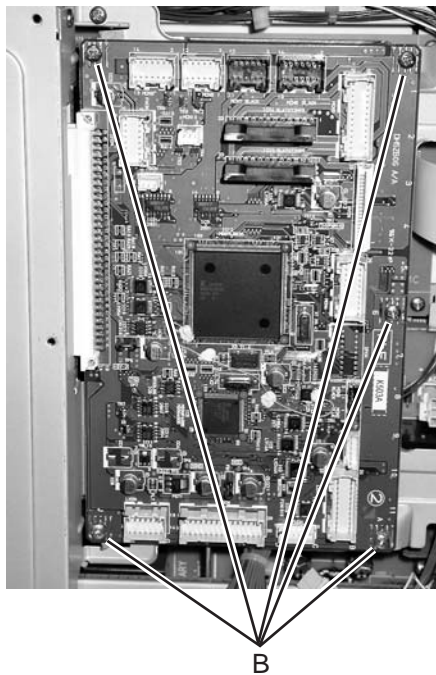

Note: When reinstalling flat cables, ensure that the blue side of the cable is opposite of the pins on the connectors. Flat cable pins are exposed on only one side (opposite blue side) and must make contact with the metal pins on the connectors.

System board removal

	<p>CAUTION</p> <p>There is a lithium battery on your system board. RISK OF EXPLOSION IF REPLACED BY AN INCORRECT TYPE The battery is non-replaceable. Do not replace, recharge, disassemble, or incinerate a lithium battery. Discard used batteries according to the country, state or local regulations.</p>
---	--

Warning: Before replacing the system board, save the onboard settings. See **“Printing the maintenance and configuration pages” on page 3-3.**

Warning: When replacing the System/RIP board, be sure to set the country code. See **“Setting the country code” on page 3-3.**

1. Disconnect any attached USB or network cables.
2. Remove the left rear cover. See **“Left rear cover removal” on page 4-16.**
3. Remove the screw (A) securing the system board cover.



4. Remove the system board cage cover.

5. Remove the screw (B) securing the two ground wires.

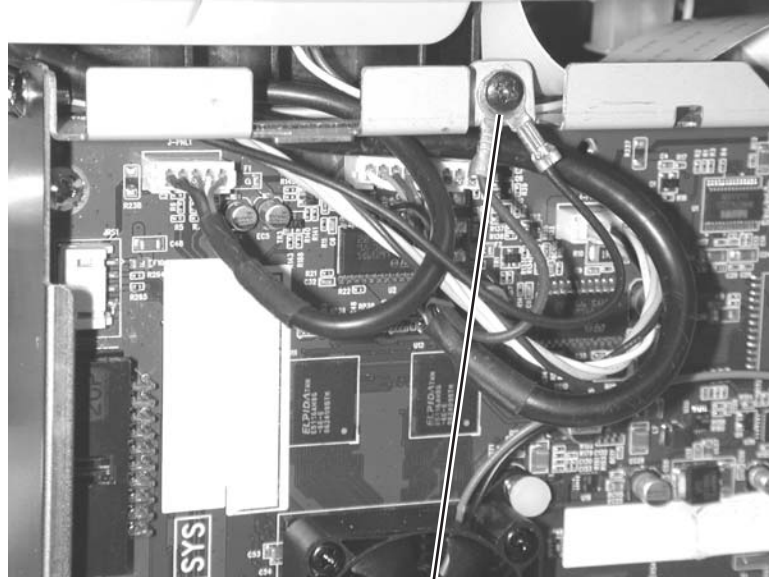

B

6. Disconnect all the cables from the system board.
7. Remove the four screws (C) securing the system board to the system board cage.

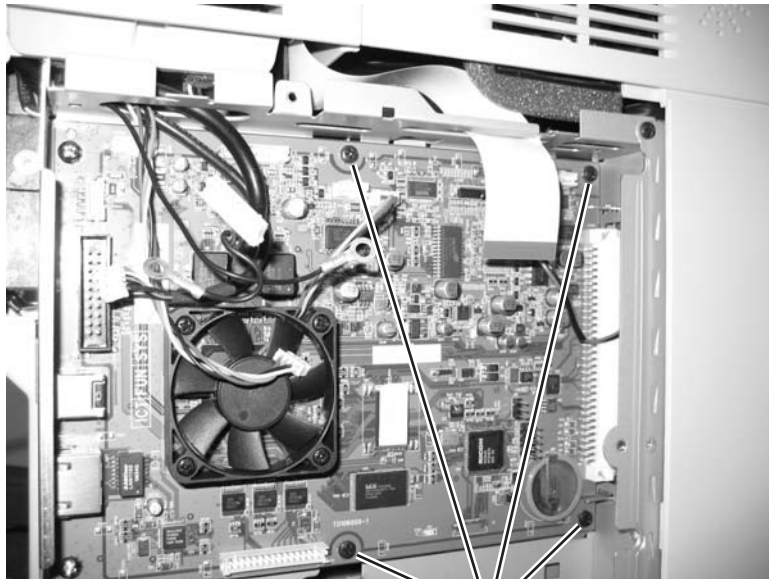

C

8. Remove two screws (D) securing the system board to the system board cage.

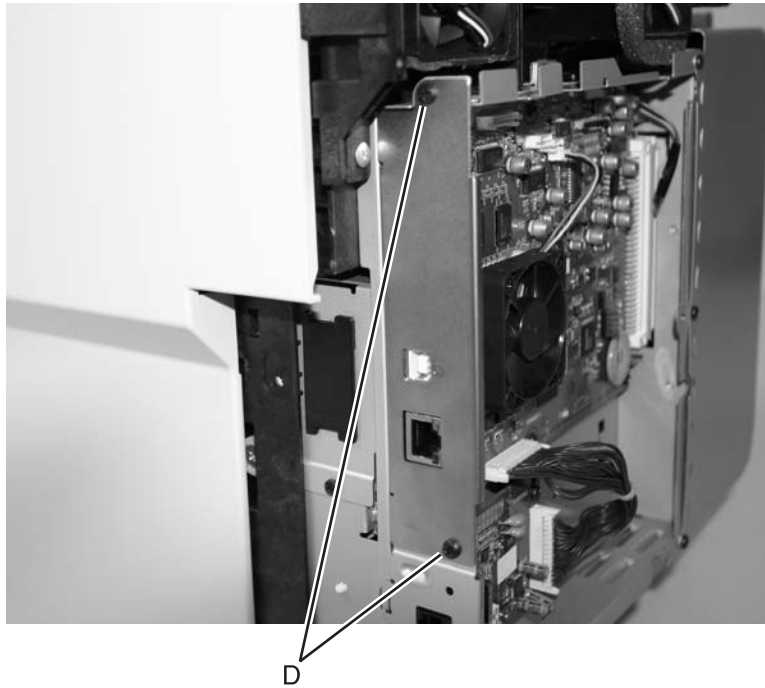

9. Slide the system board out of the MFP.

System board cage removal

1. Remove the left front cover. See **“Left front cover removal”** on page 4-15.
2. Remove the three screws (A) securing the engine card shield.
3. Remove the engine card shield.
4. Disconnect all the cables from the engine card.
5. Disconnect the modem speaker cable from the RIP card.
6. Remove the three screws (B) which secure the card cage to the printer frame.

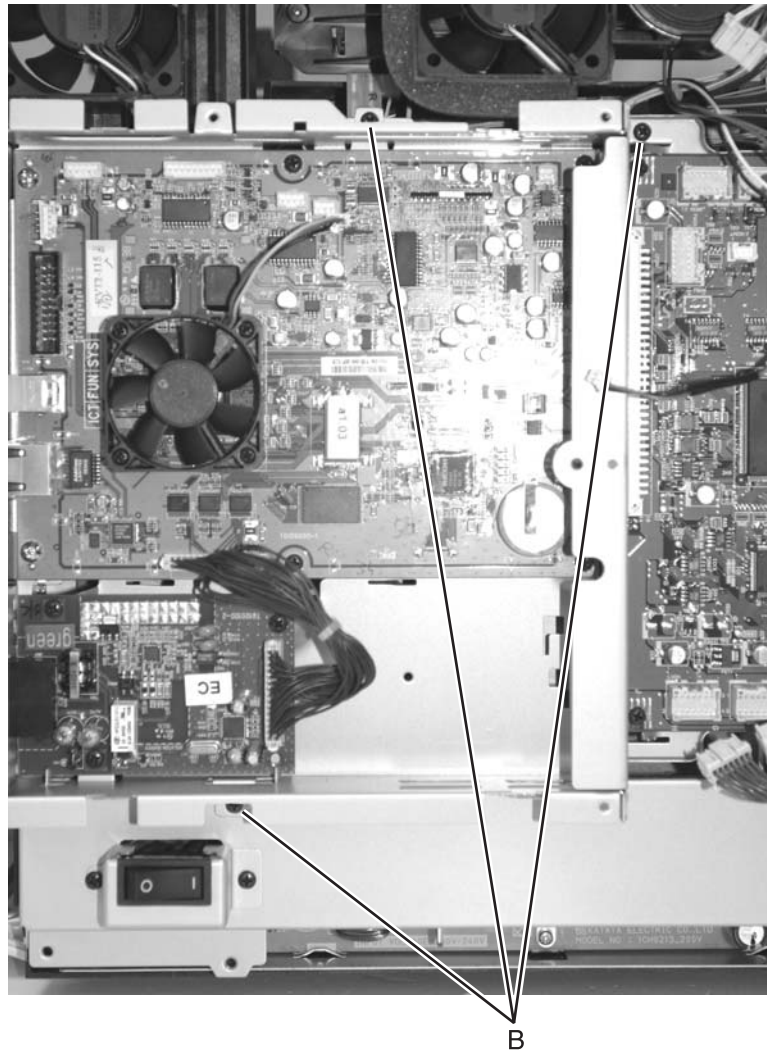

7. Carefully remove the card cage from the printer.

Note: The engine controller board and system / RIP board do not need to be removed to perform this removal.



High voltage power supply (HVPS) removal

1. Remove the RIP board cage. See **“System board cage removal” on page 4-39.**
2. Disconnect all the connectors from the HVPS.

Note: When reinstalling flat cables, ensure that the blue side of the cable is opposite of the pins on the connectors. Flat cable pins are exposed on only one side (opposite blue side) and must make contact with the metal pins on the connectors.

3. Remove 11 screws (A) (4 corner screws are gold in color (metal); inner screws are silver (plastic)); remove HVPS.

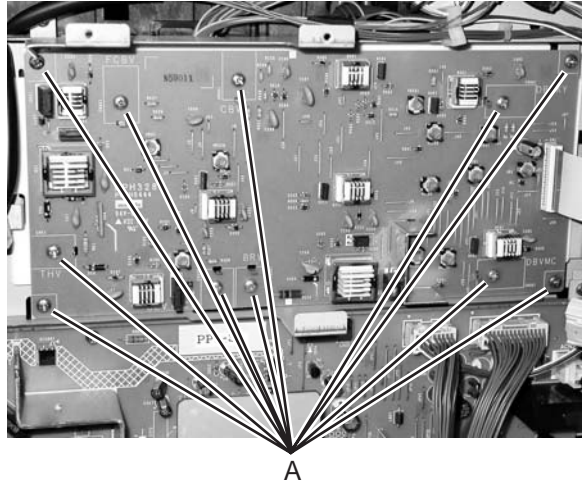



Low voltage power supply (LVPS) with cage removal

1. Remove the transfer belt unit. See **“Transfer belt unit removal”** on page 4-5.
2. Remove the RIP board cage. See **“System board cage removal”** on page 4-39.
3. Remove the grounding terminal screw (A).
4. Disconnect the power supply bracket connector (B).
5. Remove three screws (C) that attach the power supply bracket; remove the power supply bracket.

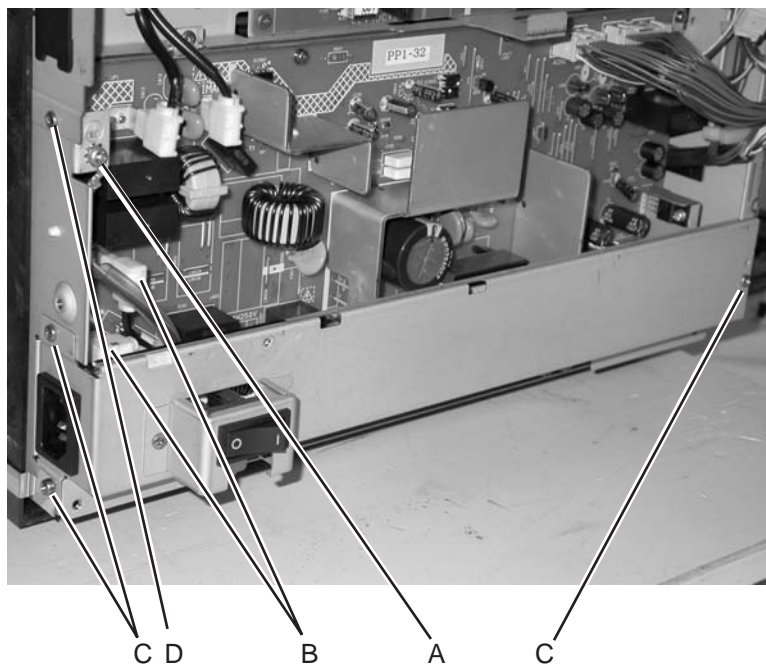

6. Remove the screw (D), and disconnect all the connectors from the LVPS.
7. Remove three metal screws (E) and 3 plastic screws (F) that attach the LVPS with the cage; remove the LVPS with the cage.

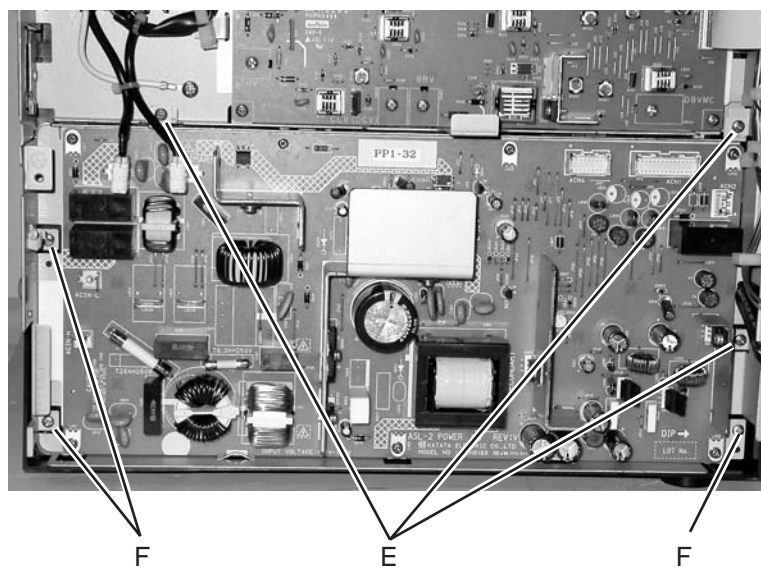

HVPS cage removal

1. Remove the HVPS. See **“High voltage power supply (HVPS) removal”** on page 4-40.
2. Remove the LVPS with cage. See **“Low voltage power supply (LVPS) with cage removal”** on page 4-41.
3. Remove three screws (A); remove the HVPS cage.

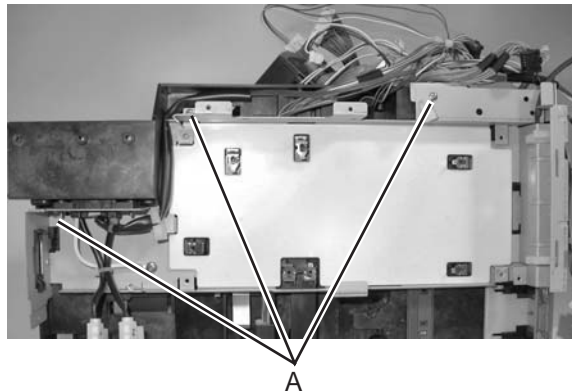

Toner present sensor removal

1. Remove the HVPS cage. See **“HVPS cage removal”** on page 4-42.
2. Remove two screws (A); remove the toner present sensor.

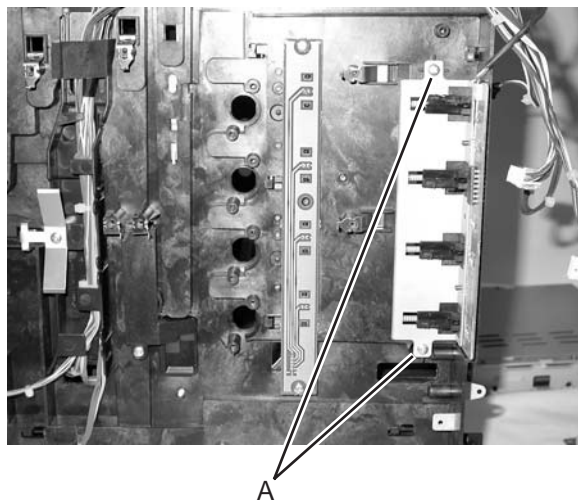

Toner sensor (receiver) removal

Note: The toner sensor is comprised of two separate parts: the sender and the receiver. The sender portion of the toner sensor is located on the right side of the MFP. See **“Toner sensor (sender) removal” on page 4-24** for removal.

1. Remove the HVPS cage. See **“HVPS cage removal” on page 4-42**.
2. Remove 2 screws (A); remove the toner sensor (receiver).
3. Disconnect the toner sensor cable from the connector (B) on the toner sensor (receiver).

Note: The bottom screw is longer than the top screw.

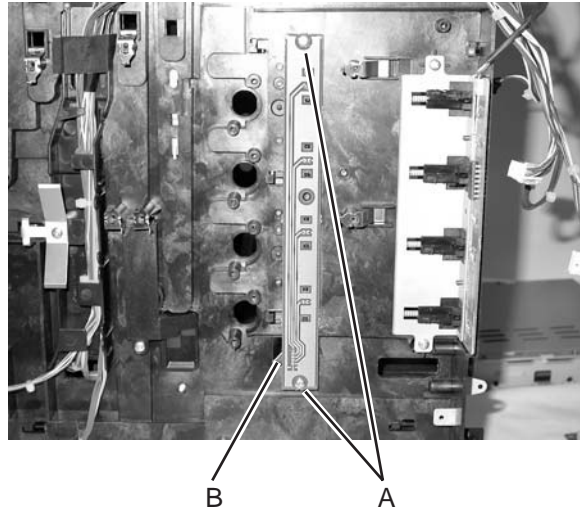

Left tray guide assembly removal

1. Remove the marker sensor. See **“Marker sensor assembly removal” on page 4-47**.
2. Remove the HVPS cage. See **“HVPS cage removal” on page 4-42**.
3. Reroute cable (A) to allow sufficient cable length for removing the left tray guide assembly from the frame.

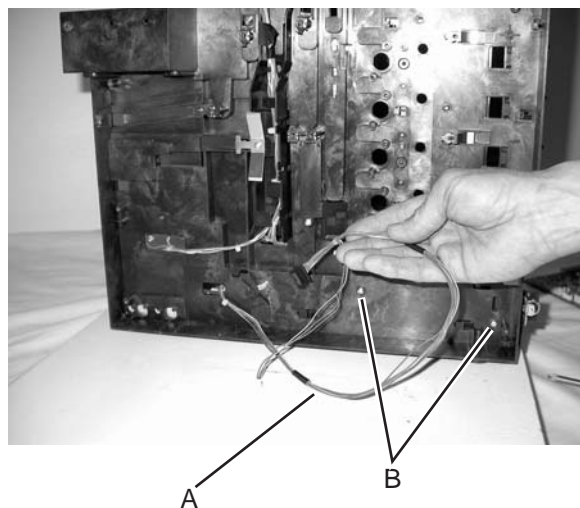

4. Remove two (B) screws that secure the left tray guide assembly to the MFP frame.

5. Slide the left tray guide assembly out in front of the MFP.

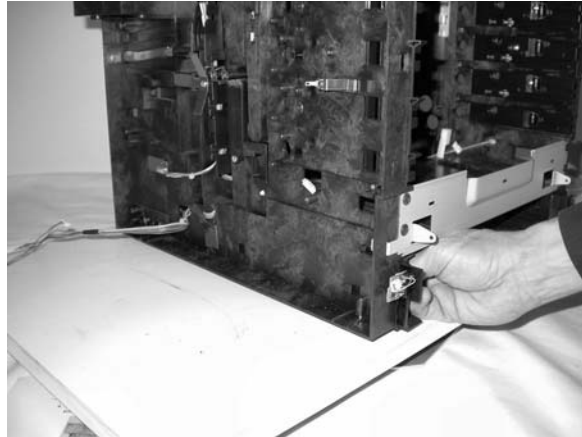

Modem speaker removal

1. Remove the left rear cover.
2. Remove the top cover.
3. Disconnect the modem speaker cable from the system / RIP board.
4. Remove the old speaker from the interlock assembly by prying the speaker retaining tabs back, and sliding the speaker out of the interlock assembly.

Fuser fan assembly removal

1. Remove the left rear cover. See **“Left rear cover removal” on page 4-16.**
2. Remove the top cover. See **“Top cover assembly removal” on page 4-10.**
3. Remove the system board. See **“System board removal” on page 4-36.**
4. Remove the screw (A) that secures the interlock assembly to the printer engine frame. Set the interlock assembly aside.

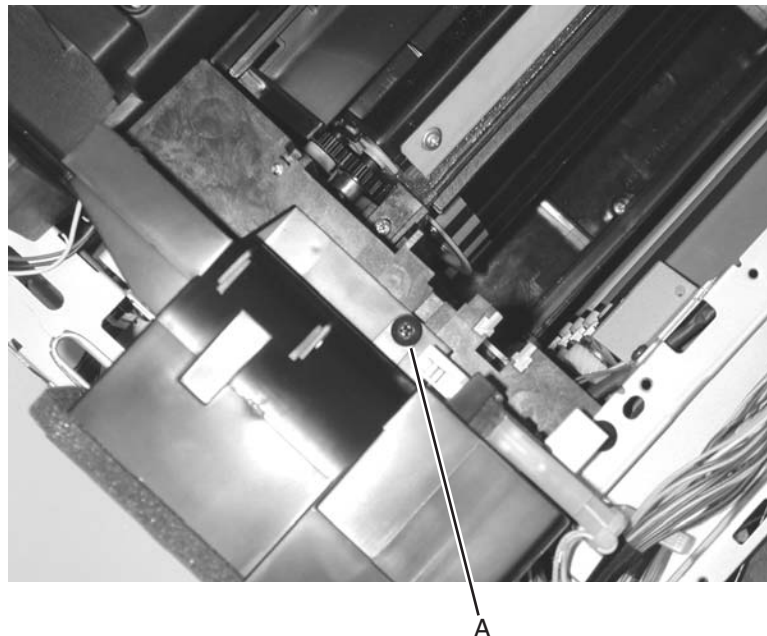

5. Disconnect the fuser fan cable from the connector (B) behind the interlock assembly.

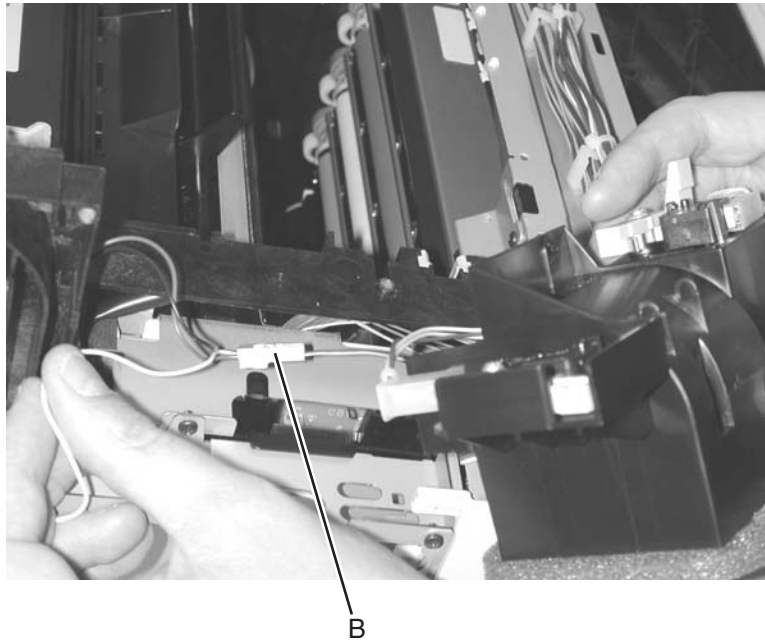

6. Remove the top screw (C) that secures the system board cage to the printer frame.

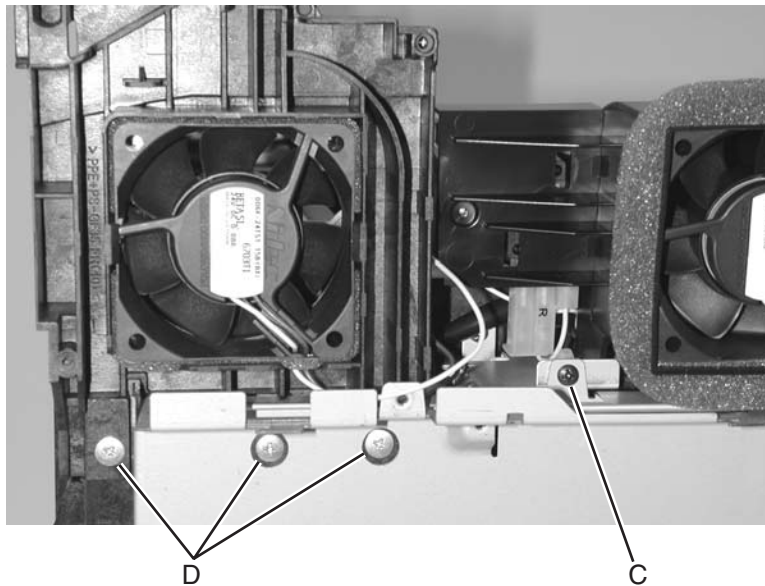

7. Remove the three screws (D) that secure the fuser fan assembly to the printer engine frame.
8. Lift and remove the fuser fan assembly.

Modem card removal

1. Remove the rip cage cover.
2. Disconnect the 30-pin cable (A) from the modem card.

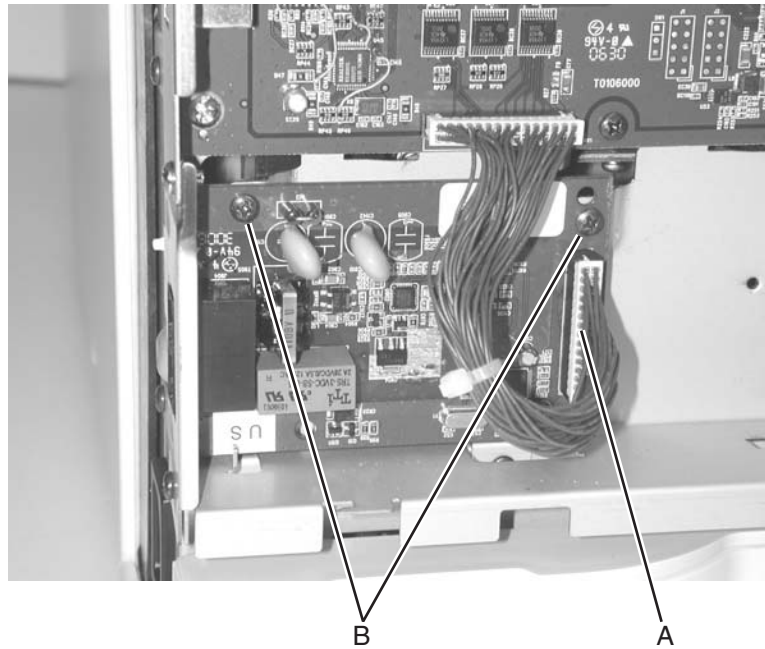

3. Remove the screws (B) that secure the modem to the RIP cage.
4. Remove the modem.

Top removals

Marker sensor assembly removal

1. Remove all the toner cartridges.
2. Remove the photodeveloper cartridge. See **“Photodeveloper cartridge removal” on page 4-8.**
3. Remove the transfer belt unit. See **“Transfer belt unit removal” on page 4-5.**
4. Remove screw (A) from the bracket.

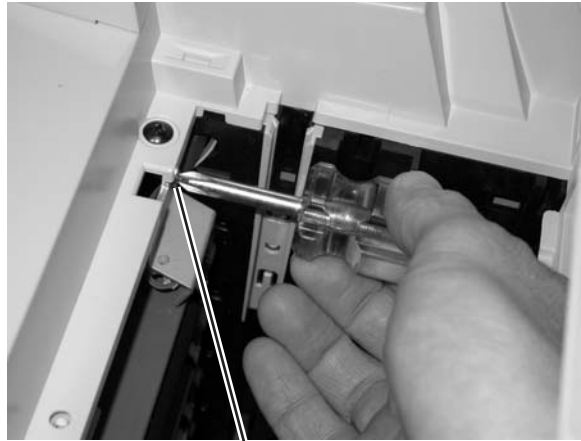

A

5. Disconnect the cable from the sensor, and remove the marker sensor assembly.

Waste toner auger removal

1. Remove the photodeveloper cartridge. See **“Photodeveloper cartridge removal”** on page 4-8.
2. Remove the transfer belt unit. See **“Transfer belt unit removal”** on page 4-5.
3. Remove the top cover assembly. See **“Top cover assembly removal”** on page 4-10.
4. Remove the transfer belt cleaning roller. See **“Transfer belt cleaning roller removal”** on page 4-4.
5. Remove two screws (A) from the waste toner auger; remove the waste toner auger.

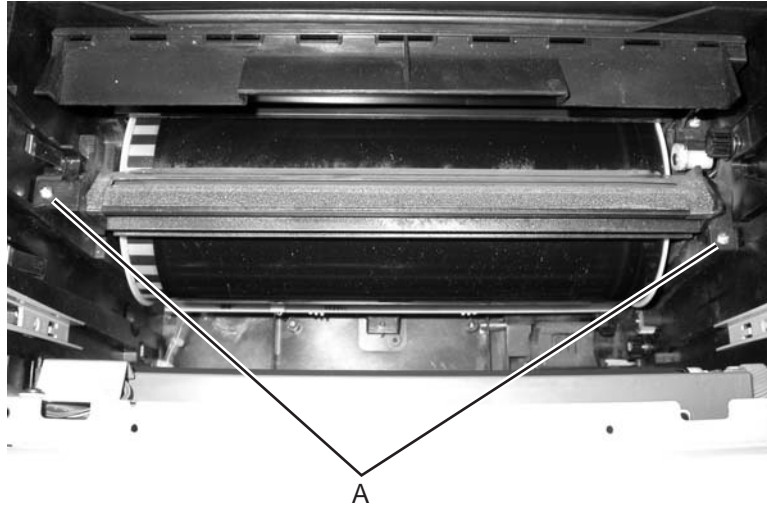

Waste toner agitator removal

1. Remove the waste toner auger. See **“Waste toner auger removal”** on page 4-48.
2. Remove gear (A) from the cleaning roller clutch.

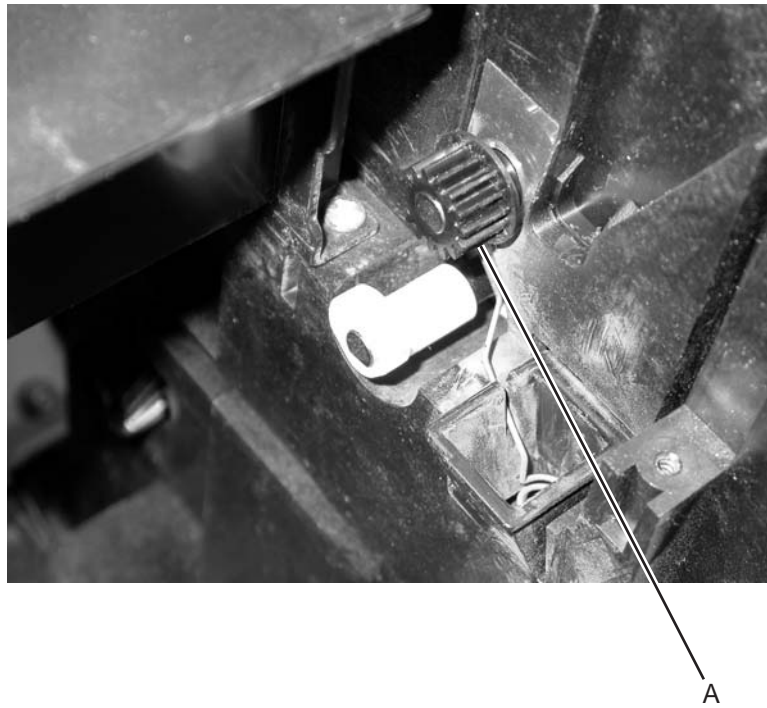

3. Pull the agitator off the shaft; lift and remove.

Power supply fan removal

1. Remove the top cover assembly. See **“Top cover assembly removal” on page 4-10.**
2. Disconnect the modem speaker cable from the system board, and carefully route the cable through the engine board cage.
3. Remove screw (A) from the power supply fan.

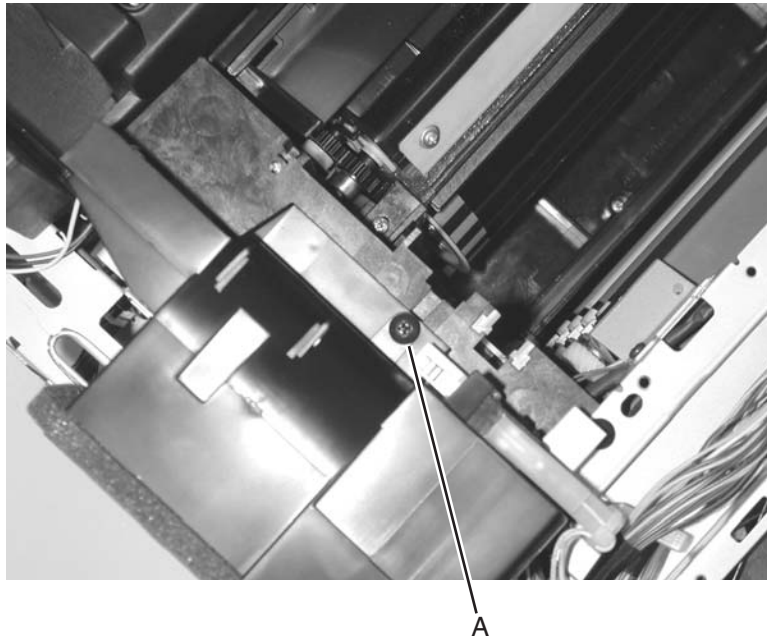

4. While holding the fan, disconnect the cables (B) from the interlock switches and remove the power supply fan.

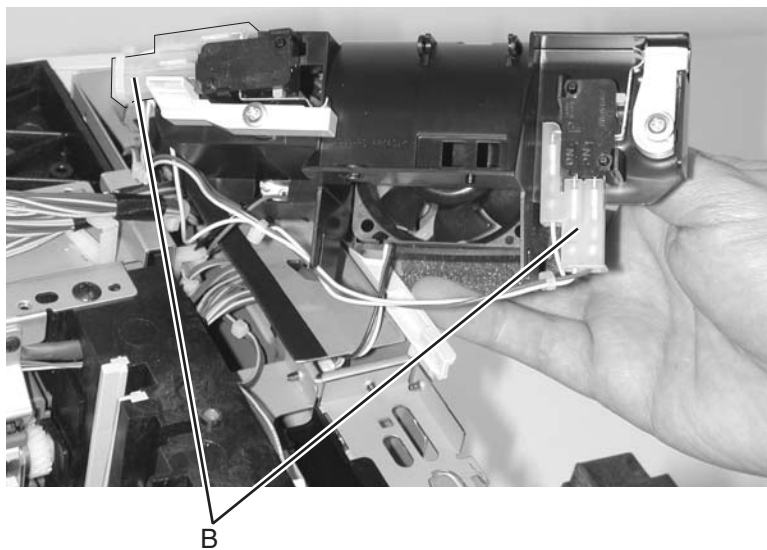

Scanner assembly removals

Flatbed assembly removal

1. Remove the left rear cover. See **“Left rear cover removal” on page 4-16.**
2. Remove the RIP/System board cover. See **“System board removal” on page 4-36.**
3. Open the MFP rear cover.
4. Remove the screws (A) securing the upper left and right covers.

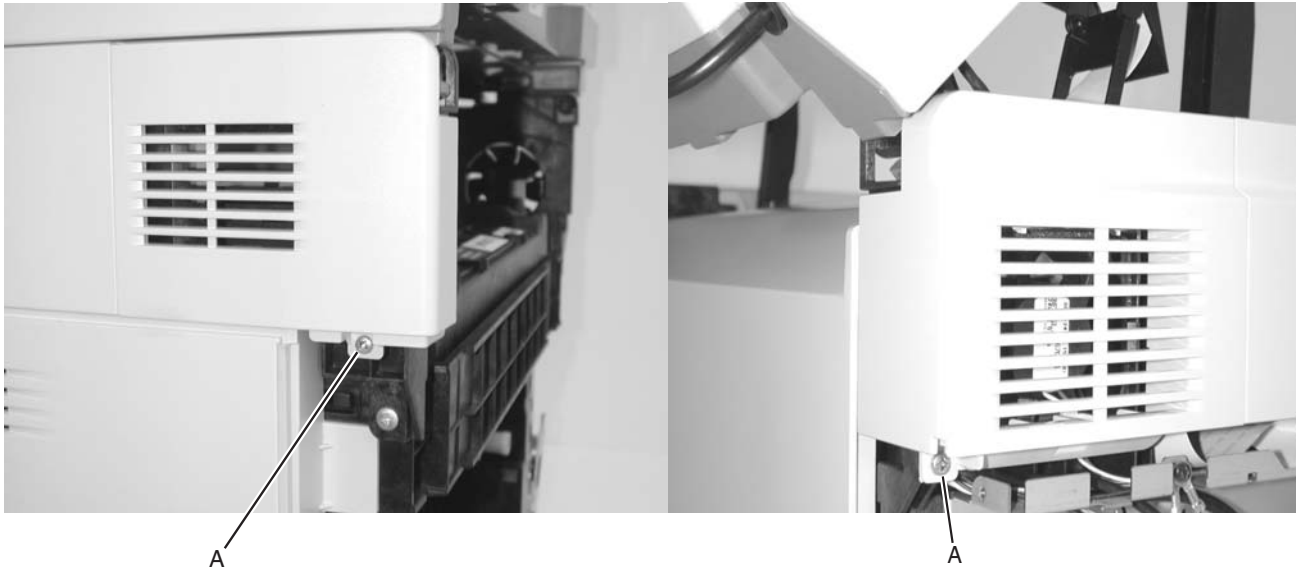

5. Remove the ADF unit. See **“ADF unit removal” on page 4-54.**
6. Disconnect the CCD ribbon cable, the operator panel cable, and the flatbed motor cable from the system board.

7. Route all the cables through the RIP cage and around the fuser fan.



8. Remove the ribbon cable guide from the ribbon cable and flatbed unit.
9. Remove the four screws (C) that attach the flatbed to the scanner arms.

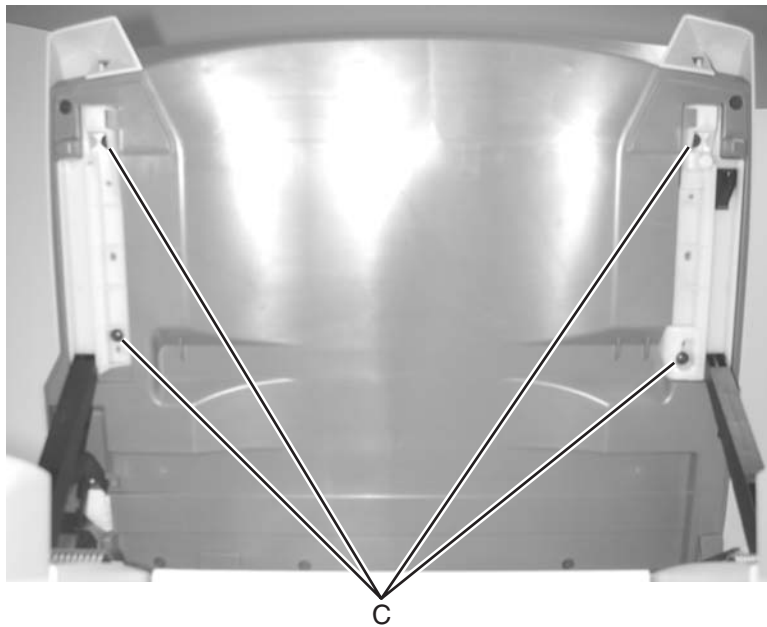

10. Tilt the scanner assembly vertically, carefully pulling the white slides off of the flatbed.

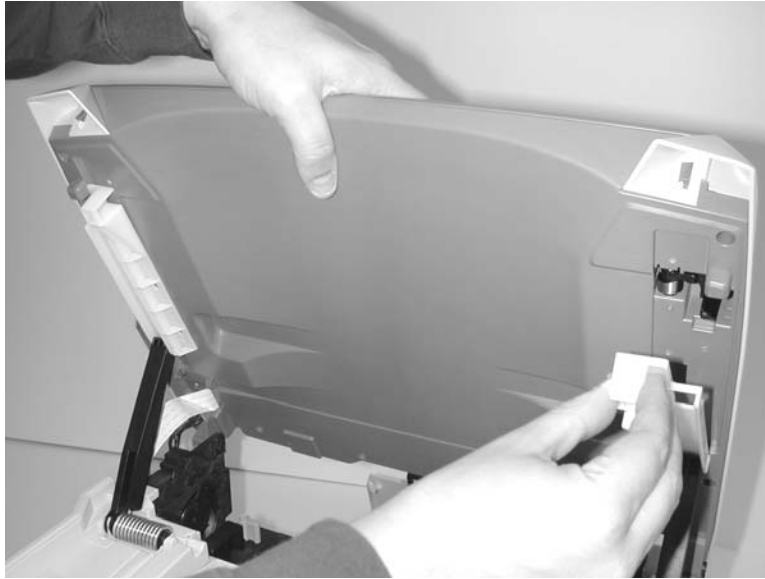

11. Lift the flatbed assembly off of the printer engine base.



Scanner arm removal

1. Remove the flatbed assembly. See **“Flatbed assembly removal”** on page 4-50.
2. Remove the screw (A) securing the scanner armlock to the printer top cover.

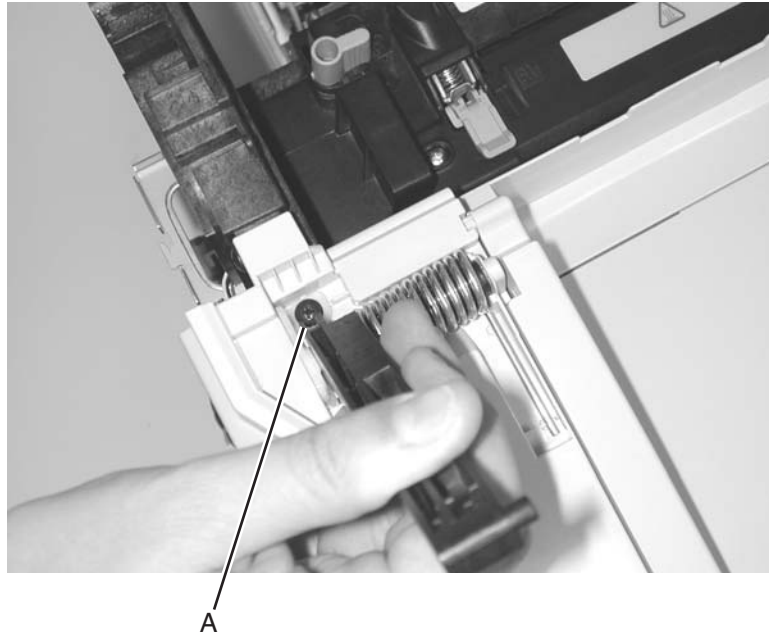

3. Tilt the top of the scanner arm to the center of the MFP, and remove the armlock (B).

Note: Save the armlock for the new scanner arm.



4. Continue tilting the scanner arm, and pull the arm outward and up.
5. Lift the scanner arm up and away from the printer top cover.

6. Repeat steps 3, 4, and 5 for the other arm, if needed.

Note: If you are replacing the scanner arm, remove the spring from the old scanner arm. The spring will go on the new arm.

ADF unit removal

1. Remove the upper left rear cover. See **“Upper left rear cover removal” on page 4-17.**
2. Remove the left rear cover. See **“Left rear cover removal” on page 4-16.**
3. Remove the system board cover.
4. Remove the screw (B) that secures the ADF, and flatbed ground wires to the RIP cage.

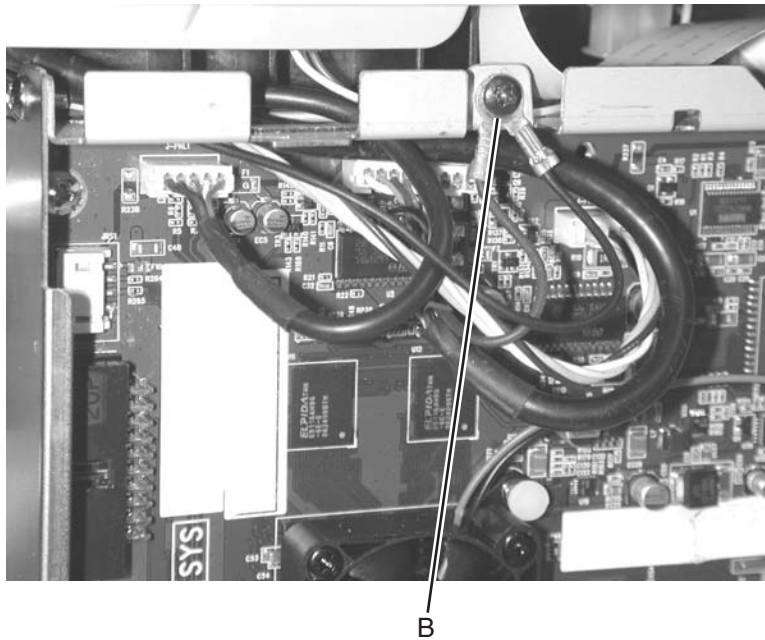

5. Disconnect the ADF cable from the system board.

6. Remove the ADF cable cover from the rear of the flatbed unit.



7. Route the ADF cable and ADF ground wire through the RIP cage and flatbed unit.



8. Lift the flatbed cover to a vertical position, and up from the flatbed.

9. With a flat-blade screwdriver, press against the tab on the ADF unit retainer.

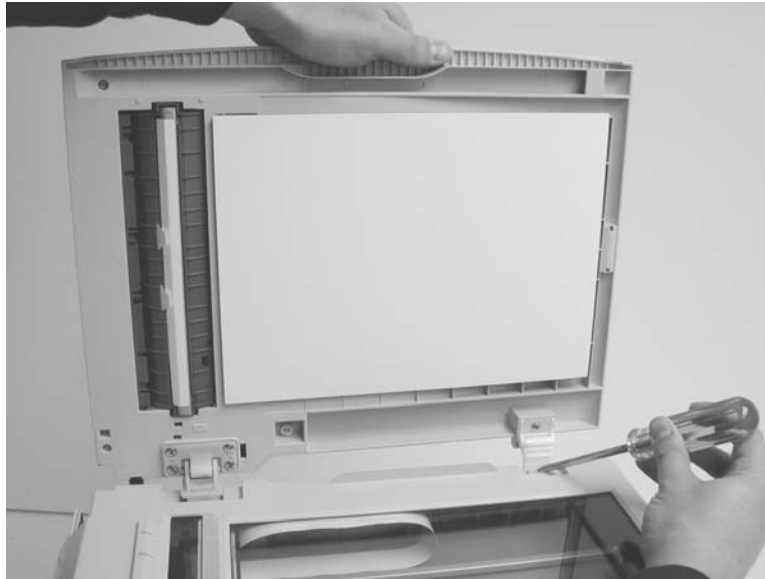

10. Lift the ADF unit up and away from the flatbed unit.

Note: Remove the ADF paper tray from the old ADF unit. It will be used on the new ADF unit.

ADF mechanism cover removal

1. Open the ADF top cover, and remove the ADF separator roll and ADF separator pad.
2. Open the flatbed cover.
3. Remove the screw (A) which secures the ADF front cover to the flatbed cover.



Note: When replacing this screw, do not overtighten it.

4. Remove the ADF front cover.
5. Remove the screw (B) which secures the ADF separator roll lock to the ADF.

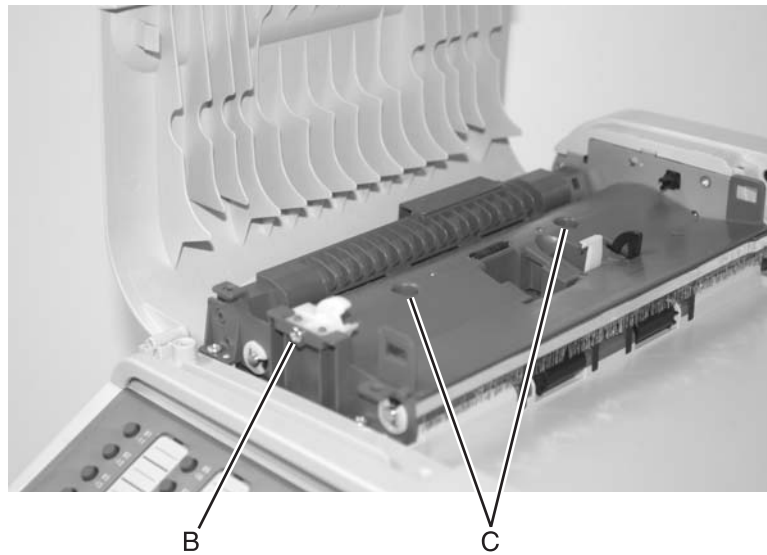

6. Remove the ADF separator roll lock.
7. Remove the two screws (C) which secures the ADF mechanism cover to the ADF.
8. Remove the ADF mechanism cover.

Operator panel removal

1. Remove the operator panel bezel by prying it off the operator panel cover.



2. Remove the two screws (A).

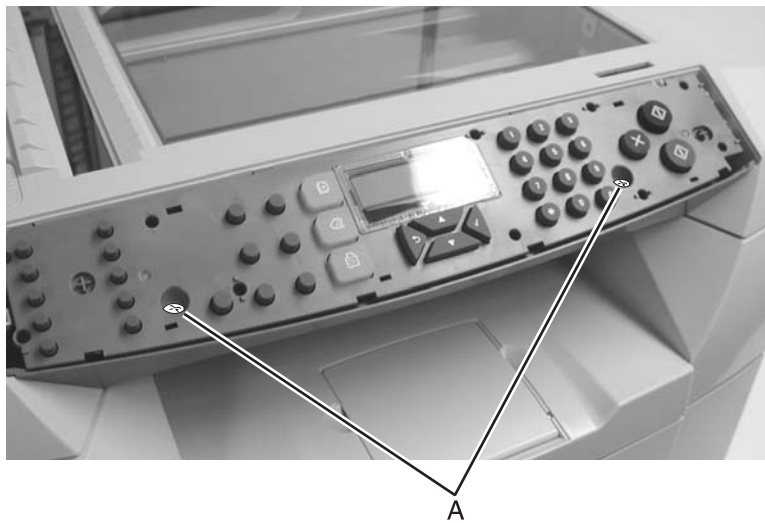

- Using a flat-blade screwdriver, carefully pry the operator panel away from the scanner assembly in four places (B).

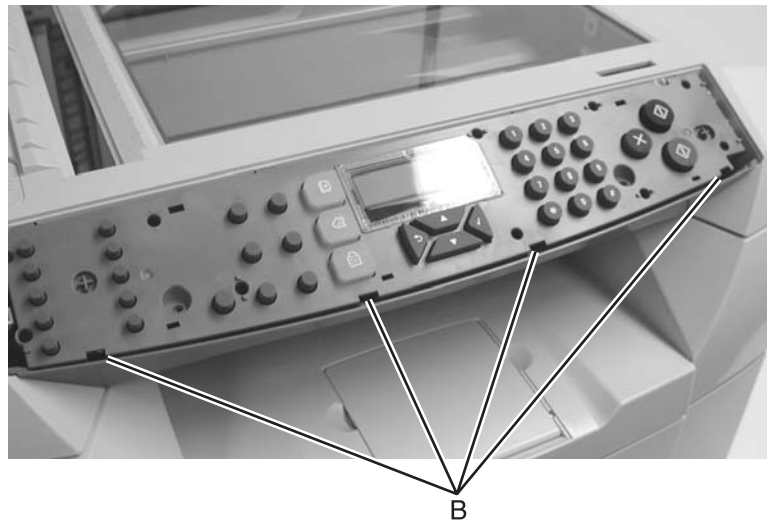

- Lift up the operator panel, and disconnect the operator panel cable (C) from the operator panel.

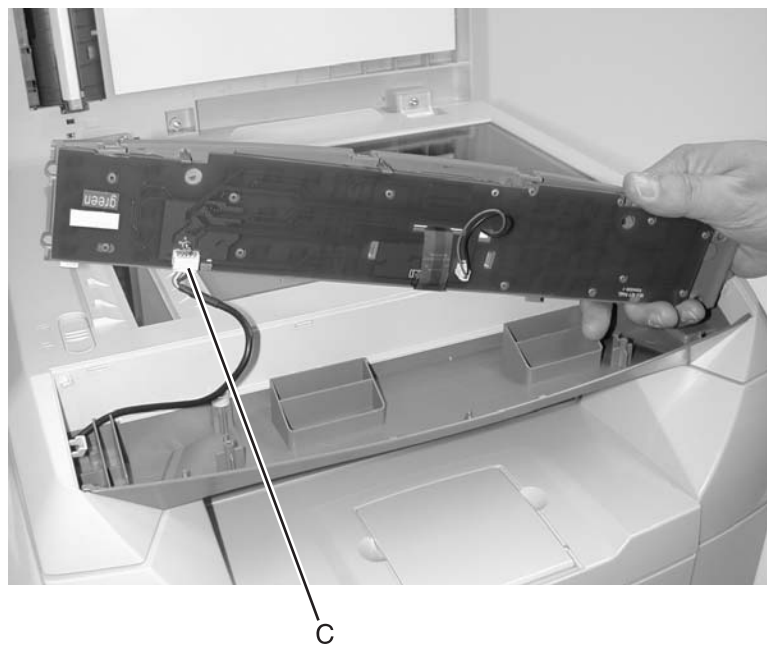

- Remove the operator panel.

7100-XXX

5. Locations and connectors

Printer front and rear views

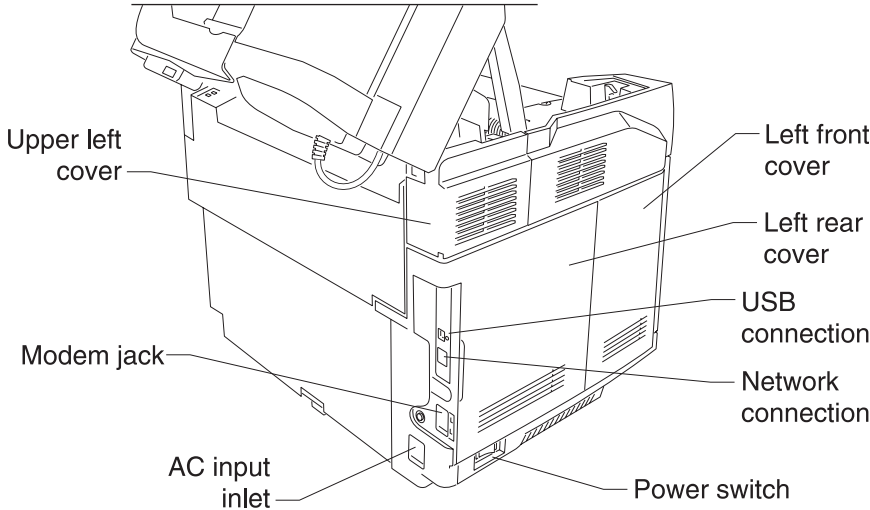
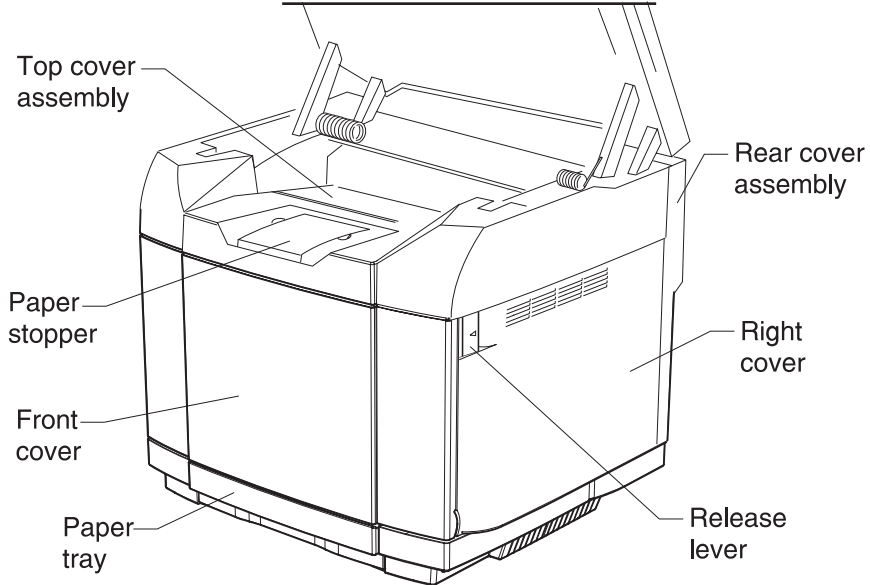

Part name	Description
Paper stopper	Stopper for exited papers.
Top cover assembly	Upper enclosure and also the paper exit tray.
Rear cover assembly	Printer rear enclosure that opens allowing clearing of internal paper jams or maintenance work.
Release lever (rear cover assembly)	Releases rear cover assembly.
Release lever (top cover assembly)	Releases the opening portion of the top cover assembly. Opening the top cover assembly allows access to the photodeveloper unit.
Right cover	Covers the right side of the printer where the motors and drives are located.
Front cover	Printer front enclosure that opens allowing toner cartridge or waste toner bottle replacement.
Paper tray	Standard paper tray that holds printer paper.
Left front cover	Covers the left side of the printer over the MFP engine card.
Left rear cover	Covers the left side of the printer over the RIP card.
Power switch	Turns the printer on and off.
Upper left cover	Covers the fuser fan.
USB connection	Connects the MFP to the host by USB.
Network connection	Connects the printer to an 10/100/1000 base T network.
AC input inlet	Connects the power cord that supplies AC power to the printer.

Scanner locations

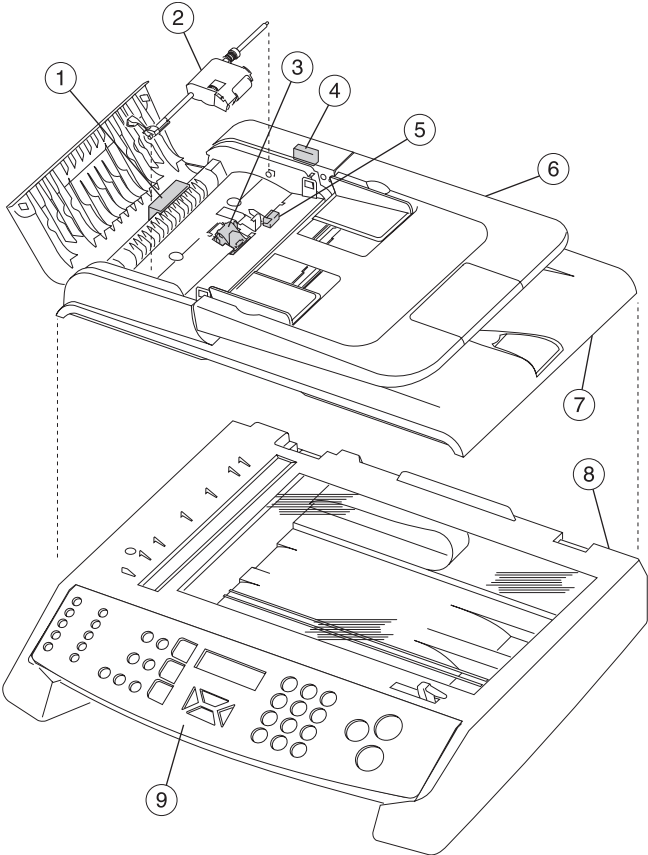

Callout	Description
1	Paperpath Sensor
2	ADF pick roll assembly
3	ADF separator assembly
4	Cover closed sensor
5	Paper present sensor
6	ADF paper tray
7	Flatbed cover / ADF Assembly
8	Flatbed assembly
9	Operator panel

Electronic components

Printer engine sensor locations

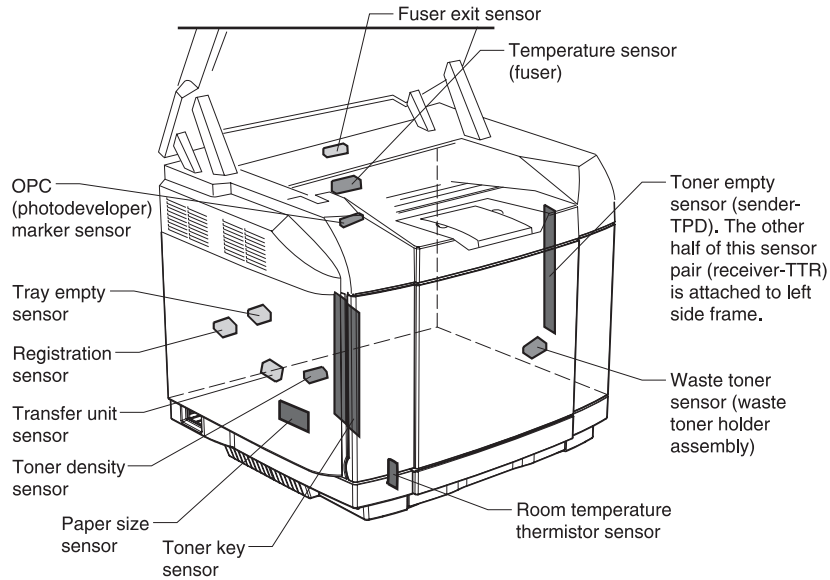

Name	Code	Function
Paper size sensor	PSU	Detects paper size.
Registration sensor	PT1	Detects whether paper is fed from paper drawer.
Fuser exit sensor	PT2	Detects when paper exits from rear cover assembly.
Tray empty sensor	PEU	Detects if paper is loaded in paper drawer.
OPC marker sensor	PBS	Detects connecting position of OPC belt.
Toner empty sensor	TPD/TTR	Detects if any toner cartridge is empty.
Waste toner sensor	WTS (LED/TR)	Detects when waste toner bottle is full.
Temperature sensor for fuser unit	TH	Thermistor that detects fuser temperature.
Output tray full sensor	PFUL	Detects when paper exit tray is full.
Toner key sensor	TNK	Detects presence of toner cartridge.
Toner density sensor	TDS	Detects toner density of images formed on the transfer belt surface.
Room temperature thermistor sensor	RTS	Detects ambient room temperature.
Transfer unit sensor	TBS	Detects irregular rotation of transfer belt.

MFP circuit board locations

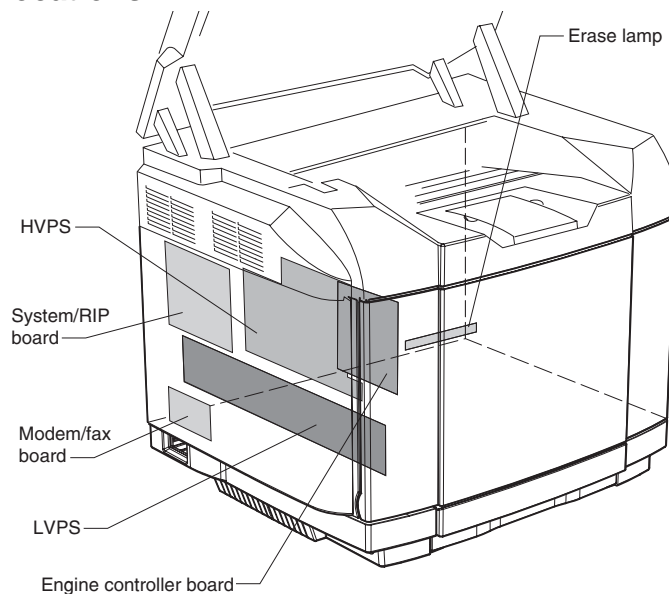

Name	Function
Engine controller board	Controls the following MFP processes Fuser temperature control Laser output control Toner empty sensing control Error processing control interface control
System/RIP Board	Controls flatbed and ADF functionality Host connectivity Controls flatbed and ADF functionality Operator panel indication
Modem/Fax board	Controls fax transmission and reception.
Erase lamp	Discharges OPC belt located in the photodeveloper cartridge.
Low voltage power supply (LVPS)	Provides power to control the MFP.
High voltage power supply (HVPS)	Provides power necessary for the printing process.

Fan/motor and interlock switch locations

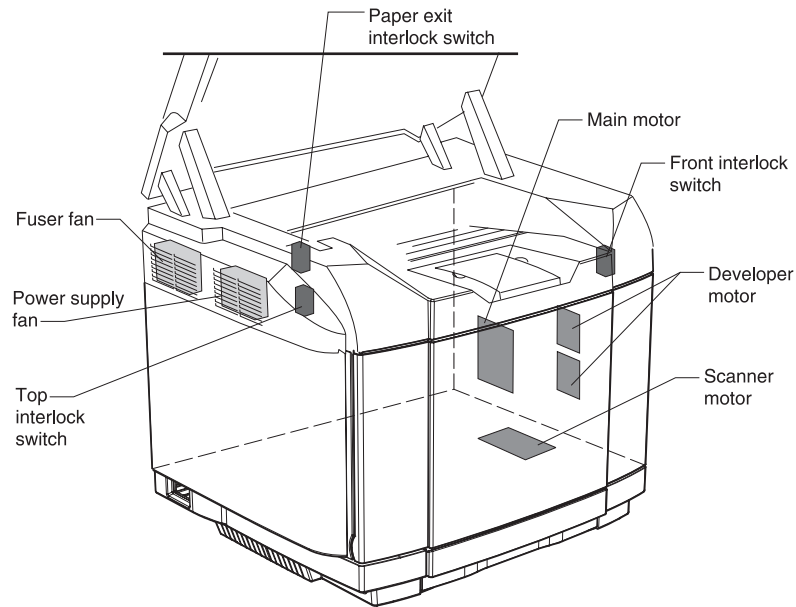

Name	Code	Function
Main motor	MM	Drives OPC belt and paper transport system.
Developer motors	DM	Drives toner cartridge and developing system.
Scanner motor	SCM	Drives laser beam scanning in optical unit
Power supply fan	PSFAN	Exhausts heat from power supply unit and interface controller.
Exit fan	EXFAN	Exhausts heat from fusing unit.
Laser fan	LDFAN	Exhausts heat from laser assembly (printhead).
Front interlock switch	DSW1	Safety interlock switches that break power when covers are opened.
Paper exit assembly interlock switch	DSW2	
Top interlock switch	DSW3	

Clutch locations

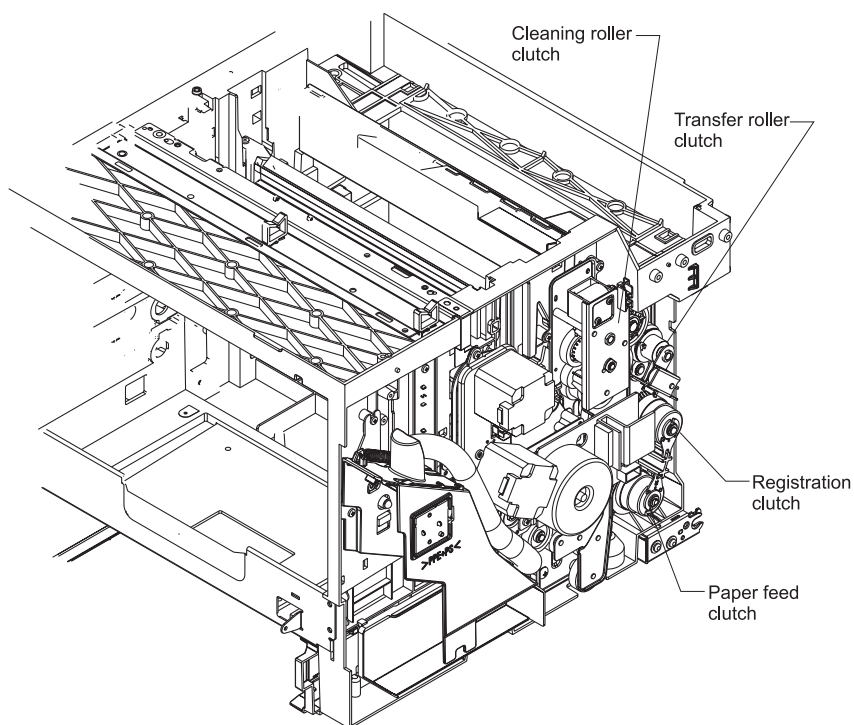

Name	Code	Function
Paper feed clutch	PCLU	Feeds paper by coupling feed roller to the main gear unit at the time of a paper feed.
Registration clutch	RECL	Transports paper by coupling registration roller to main gear unit as synchronized with rotation of transfer belt.
Cleaning roller clutch	FBCL	Drives the transfer belt cleaner brush by coupling cleaning clutch to main gear unit at the time of transfer belt cleaning.
Transfer roller clutch	TRCL	Cam action clutch that rotates, allowing transfer roller to press against the back of paper during second transfer. The transfer roller touching the back of paper causes toner to release from transfer belt onto paper during second transfer process.

Symbol and part name table

Symbol	Part name	Symbol	Part name
BR	Back-up roller	MCTL	Main engine (MCTL P.W.B.) board
CTFAN	Control fan motor (cooling fan PS)	MM	Main motor
DM	Developer motor	Optical unit	Optical unit
DPJ	Drum jam sensor	PANEL	Operator panel P.W.B.
DSW1	interlock switch (front)	PBS	Belt sensor
DSW2	interlock switch (top)	PCLU	Upper paper feeding clutch
DSW3	interlock switch (rear)	PDU	PDU P.W.B.
Erase lamp	Erase lamp	PEU	Upper paper empty sensor
FBCL	Cleaning roller solenoid	PFUL	Exit paper full sensor
FBSOL	Cleaning cam clutch	PSU	Upper paper size sensor
FCS	Cleaning roller sensor	PT1	Paper feed sensor
FUSER unit	Fuser unit	PT2	Paper exit sensor
HPSEN	Drum encoder sensor	RECL	Registration clutch
HR	Heater roller	SCM	Scanner motor
HTFAN	Heater fan motor (cooling fan EX)	TBLE TBFL	Waste toner sensor (WT holder assembly)
HVU	High voltage unit	TFU1 TFU2	Thermal fuse
LCD	LCD P.W.B.	TH	Thermistor
LDU	Laser drive unit P.W.B.	TNK	Toner key sensor
LFU	Lower paper feeding unit	TPD TTR	Toner empty sensor
LVPS	Power supply unit	TRCM	Transfer cam clutch

Engine controller board wiring diagram

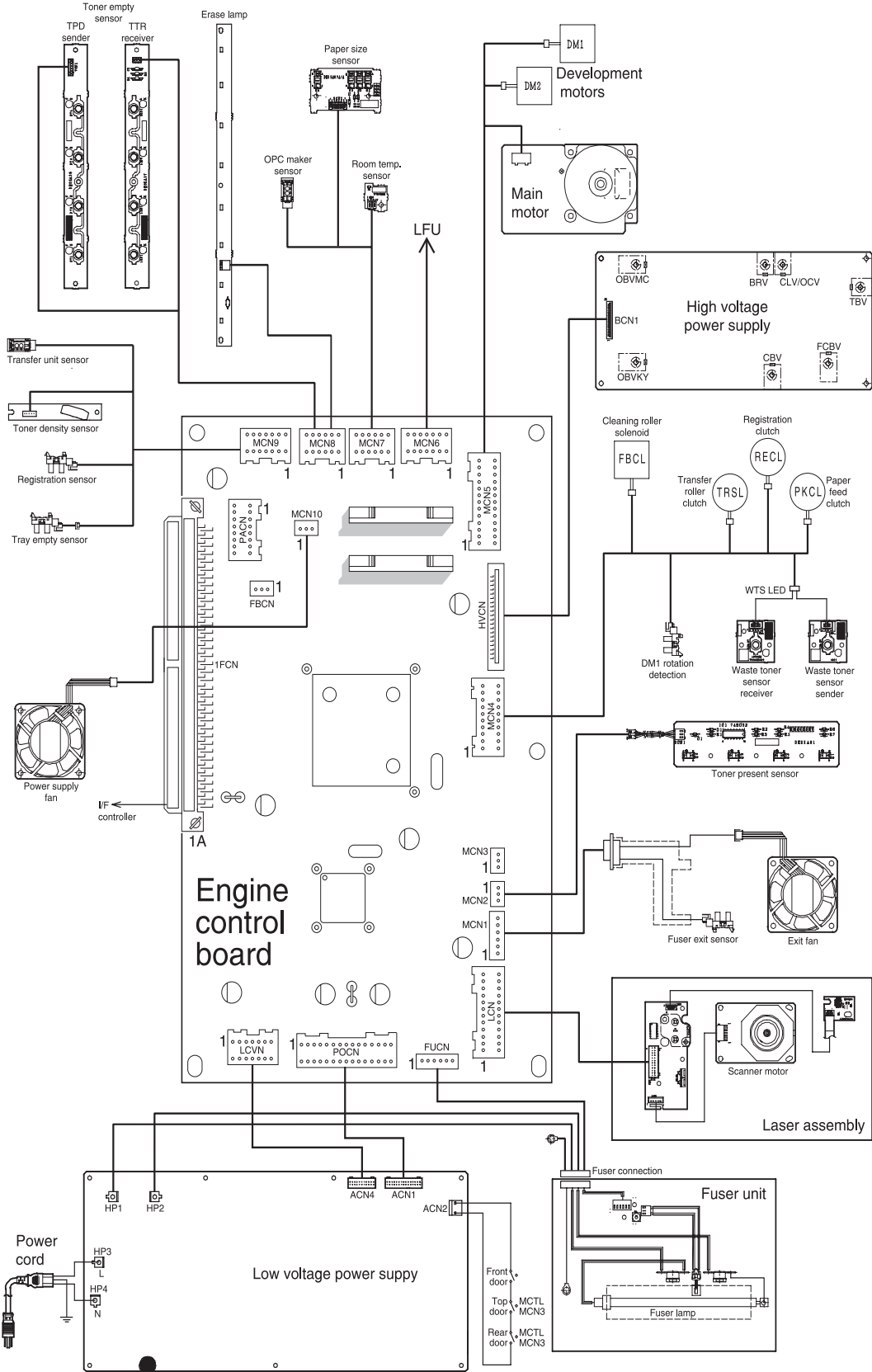

Engine controller board connections

HVCN-21 pin. Connects to HVPS			
Pin #	Voltage / Signal	Pin #	Voltage / Signal
1	HVUCNCHK-N	12	BRVPWM-N
2	PGND	13	PWMON-N
3	ID [PGND]	14	DCVP-N
4	FCBVPWM-N	15	BRVON-N
5	THV-I	16	+24V -1D
6	DBV [KY] PWM-N	17	+24V -1D
7	THVPWM-N	18	+24V -1D
8	DBV [MC] PWM-N	19	PGND
9	THVRON	20	PGND
10	CBVPWM-N	21	PGND
11	BRVERR		
LCN-24 Pin. Connects to LSU assembly			
Pin #	Voltage / Signal	Pin #	Voltage / Signal
1	+5V - 1R	13	BDT-P
2	LCONT-1	14	LDREF-0
3	LREADY	15	BDT-N
4	LCONT2	16	VCC
5	SGND	17	SGND
6	LDREF-4	18	SGND
7	VIDEO-N	19	SCMRDY-N
8	LDREF-3	20	SCMCLK
9	VIDEO-P	21	PGND
10	LDREF-2	22	SCMON-N
11	SGND	23	+24V-1
12	LDREF-1	24	+3.3V

MCN9-14 Pin. Connects to transfer unit, toner density, registration and paper sensors			
Pin #	Voltage / Signal	Pin #	Voltage / Signal
1	+5V-S	8	V02:k
2	VCC	9	PTI-N
3	TBEN-N	10	V01-YMC
4	LED	11	SGND
5	SGND	12	+5V-S
6	SGND	13	SGND
7	+5V-S	14	PEV-P
MCN2- 3 Pin. Toner present sensor			
Pin #	Voltage / Signal	Pin #	Voltage / Signal
1	Toner OK-N	3	SGND
2	+5V-S		
MCN10-3Pin. Power supply fan			
Pin #	Voltage / Signal	Pin #	Voltage / Signal
1	CTFANON-P	3	CTFANERR
2	PGND		
MCN7-12 Pin. Marker, paper size, room thermistor			
Pin #	Voltage / Signal	Pin #	Voltage / Signal
1	PBSEN-N	7	NC (SGND)
2	VCC	8	PSU3
3	+5V-S	9	SGND
4	PSU1	10	PSU4
5	SGND	11	TH3
6	PSU2	12	SGND
MCN1-6 Pin. Exit Fan			
Pin #	Voltage / Signal	Pin #	Voltage / Signal
1	+5V-S	4	HTFANON-P
2	PT2-N	5	PGND
3	SGND	6	HTFANERR

MCN4-20 Pin. Clutches, waste toner sensor			
Pin #	Voltage / Signal	Pin #	Voltage / Signal
1	+24V-1DF3	11	TBFULL-N
2	FBCLON-N	12	SGND
3		13	WTLEDON
4		14	SGND
5	+24V-1DF3	15	+5V-S
6	TRSLON-N	16	DM1SEnIn
7	+24V-1DF3	17	SGND
8	RECLON-N	18	
9	+24V-1DF3	19	
10	PKCLU10N-N	20	
MCN5-26 Pin. Dev motors 1&2, main motor			
Pin #	Voltage / Signal	Pin #	Voltage / Signal
1	DM1 OUT	14	MMGAin
2	+24V-1D(B-COM)	15	MMREV-N
3	DM1 OUT	16	MMENC
4	DM1 OUT	17	VCC
5	+24V-1D(A-COM)	18	SGND
6	DM1 OUT	19	PGND
7	DM2 OUT	20	PGND
8	+24V-1D(B-COM)	21	+24V-1D
9	DM2 OUT	22	PGND
10	DM2 OUT	23	+24V-1D
11	+24V-1D(A-COM)	24	MMCLK
12	DM2 OUT	25	MMON-N
13	NC(SGND)	26	MMRDY-N

MCN6-14 Pin. LFU			
Pin #	Voltage / Signal	Pin #	Voltage / Signal
1	LFCN-RET	8	PSCST1
2	+24 - F2	9	PEL1--P
3	PKCLL10N-N	10	OCST1-N
4	NC (SGND)	11	SGND
5	PSL1	12	+5V-S
6	PSL2	13	LFCN-CHK-N
7	PSL3	14	+5V-1
MCN8 - 12 Pin Toner Sensor (TTR, TDP)			
Pin #	Voltage / Signal	Pin #	Voltage / Signal
1	LEDON-P	7	NC (SGND)
2	TLES (K)-P	8	TLES (C)-P
3	TLESCHK	9	TLESSCN-N
4	TLES (Y)-P	10	SGND
5	SGND	11	ELON-N
6	TLES (M)-P	12	+24V -F2
LVCN-14 Pin LVPS			
Pin #	Voltage / Signal	Pin #	Voltage / Signal
1	+5V	8	ACSYNC-N
2	+5V	9	+24V
3	+24V	10	PGND
4	NC (SGND)	11	+24V
5	HON	12	PGND
6	ACOFF-P	13	CN-CHK
7	LVPS	14	SGND
FUCN-6Pin			
Pin #	Voltage / Signal	Pin #	Voltage / Signal
1	TH1	4	TH2
2		5	FUTEMP
3		6	SGND

POCN-30 Pin. LVPS			
Pin #	Voltage / Signal	Pin #	Voltage / Signal
1	+5V - (CNT)	16	SGND
2	PSGNT (CNT)	17	+5V -1
3	+5V - (CNT)	18	SGND
4	PSGNT (CNT)	19	PGND
5	+5V - (CNT)	20	PGND
6	PSGNT (CNT)	21	+24V -1D
7	+3.3V - 2	22	PGND
8	PSGND	23	+24V -1D
9	+3.3V-2	24	PGND
10	PSGND	25	+24V
11	+3.3V - 2	26	PGND
12	PSGND	27	+24V -1D
13	+5V -1	28	PGND
14	SGND	29	+24V
15	+5V -1	30	PGND

RIP board

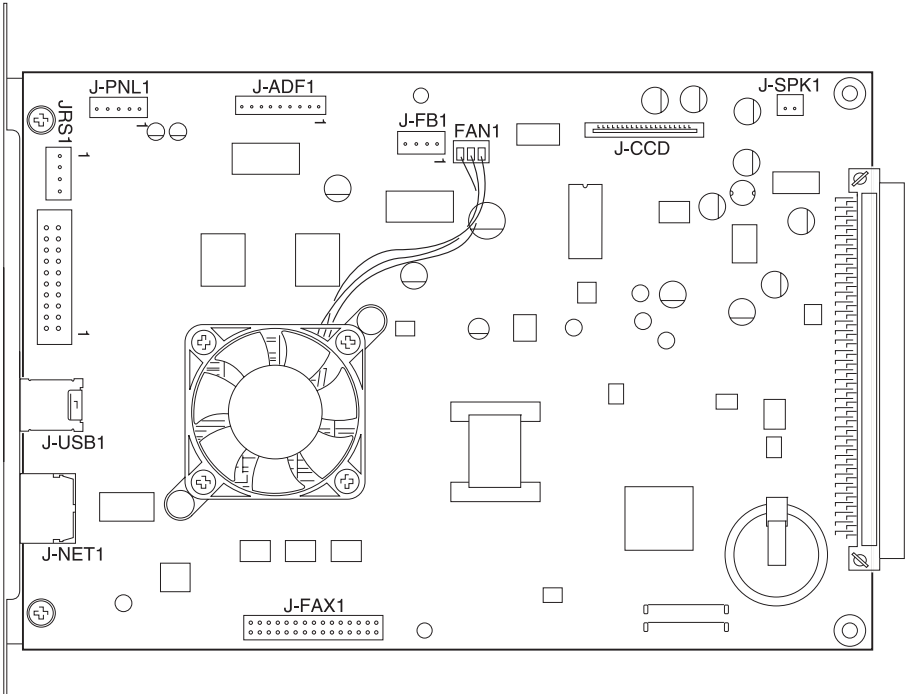

RIP card voltages

Connector / Pin #	Voltage / Signal
J-PNL1/Pin 1	+5V
J-ADF-1/Pin 5	+2.5V
J-FB1/Pin1	+5V
J-CCD / Pin 8	+12V
J-CCD / Pin 10	+5V
J-CCD / Pin12	+3.3
J-CCD / Pin 16	+3.3V
J-CCD / Pin 20	+5V

Engine controller board

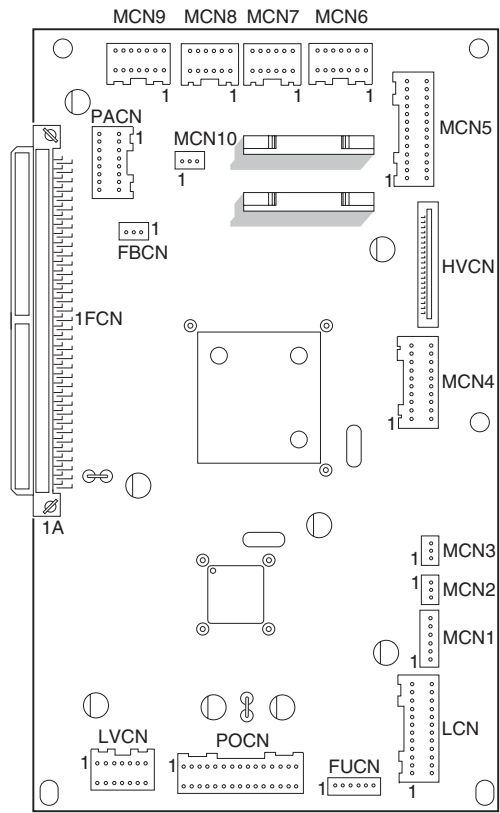

Low voltage power supply (LVPS) board

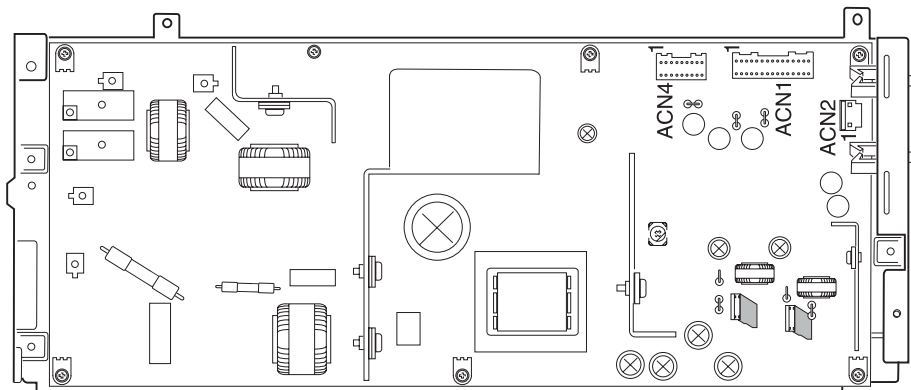

High voltage power supply (HVPS) board

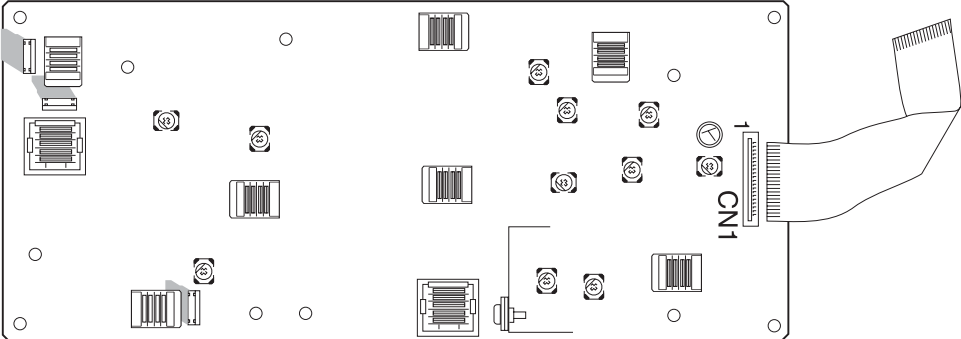

Modem Card voltages and signals

Pin Number	Signal
1	+3.3 V
2	+3.3V
3	Signal
4	Signal
5	Signal
6	Signal
7	Signal
8	Signal
9	Signal
10	Signal
11	Signal
12	Signal
13	Signal
14	Signal
15	Signal
16	Signal
17	SCS3
18	Signal
19	SRD
20	IRQN
21	SWR
22	Signal
23	Reset
24	GND
25	Signal
26	Signal
27	GND
28	GND
29	Signal
30	SSD_PWM

6. Preventive maintenance

There is no preventive maintenance performed by a service technician for this printer. Maintenance parts for the X5xx series MFPs are installed by the customer.

7100-XXX

7. Parts catalog

How to use this parts catalog

- **SIMILAR ASSEMBLIES:** If two assemblies contain a majority of identical parts, they are shown on the same list. Common parts are shown by one index number. Parts peculiar to one or the other of the assemblies are listed separately and identified by description.
- **NS: (Not Shown)** in the Asm-index column indicates that the part is procurable but is not pictured in the illustration.

Assembly 1: Base printer

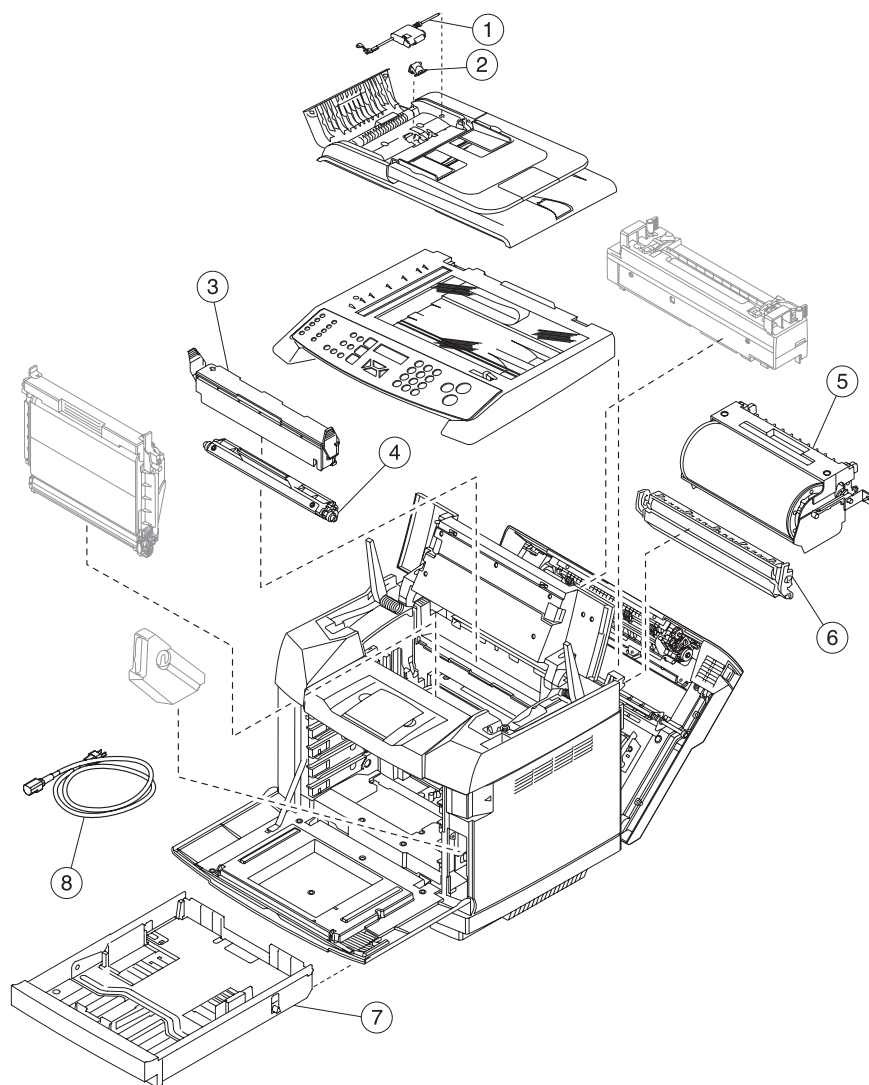

Assembly 1: Base printer

index	P/N	Units	Description
1-1	40X4702	1	ADF separator roll assembly
2	40X4703	1	ADF separator pad
3	40X3383	1	Cover, cleaning roller
4	40X3382	1	Roller, cleaning
5	40X3412	1	Transfer unit
6	40X3418	1	Transfer roller assembly
7	40X4694	1	Paper tray, universal
8	40X0297	1	Power cord, USA
8	40X1766	1	Power cord, LV, USA, APG, Bolivia, Canada, Columbia, Costa Rica, Ecuador, El Salvador, Guatemala, Honduras, Mexico, Nicaragua, Panama, Peru, Venezuela
8	40X0301	1	Power cord, HV, Argentina
8	40X1767	1	Power cord, HV, Brazil
8	40X0273	1	Power cord, HV, Chile
8	40X0286	1	Power cord, HV, UK, Ireland
8	40X0278	1	Power cord, HV, Austria, Belgium, Euro English, Finland, France, Germany, Greece, Netherlands, Norway, Poland, Portugal, Russia, Slovakia/Czech/Hungary, Spain, Sweden, Turkey
8	40X0275	1	Power cord, HV, Israel
8	40X0274	1	Power cord, HV, Switzerland French, Switzerland German, Switzerland Italian
8	40X0276	1	Power cord, HV, South Africa
8	40X0287	1	Power cord, HV, Italy
8	40X0279	1	Power cord, HV, Denmark
NS	40X4716	1	Cover, Legal Extender

Assembly 2: Covers

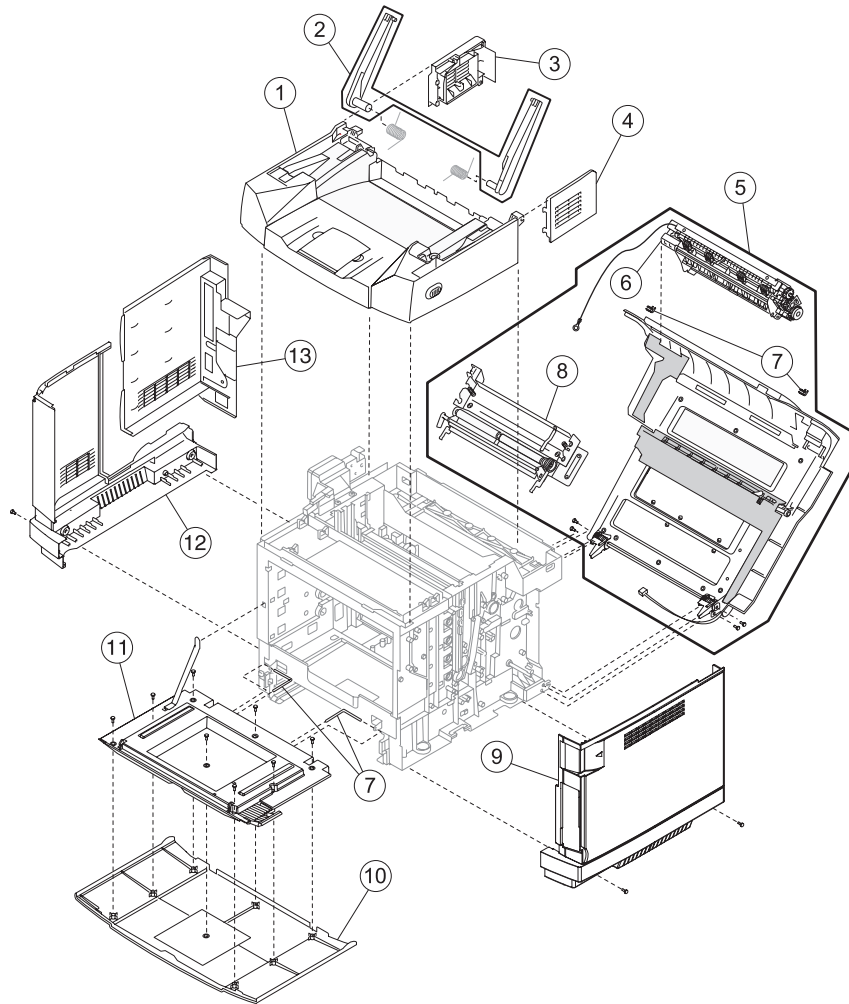

Assembly 2: Covers

index	P/N	Units	Description
2-1	40X4686	1	Cover assembly, top
2	40X4706	1	Arm, scanner (contains the left and right arms)
3	40X4698	1	Cover, top left
4	40X4699	1	Cover, top right
5	40X4692	1	Rear cover assembly (includes 40X3428, and 40X3430)
6	40X3428	1	Assembly, paper exit (contains fuser exit sensor and flag)
7	40X4718	1	Packet, parts
8	40X3430	1	Assembly, registration
9	40X3385	1	Cover, right
10	40X3388	1	Cover, front
11	40X3387	1	Cover, inner front
12	40X4687	1	Cover, front left
13	40X4688	1	Cover, rear left
NS	40X4716	1	Cover, legal extender

Assembly 3: Scanner unit

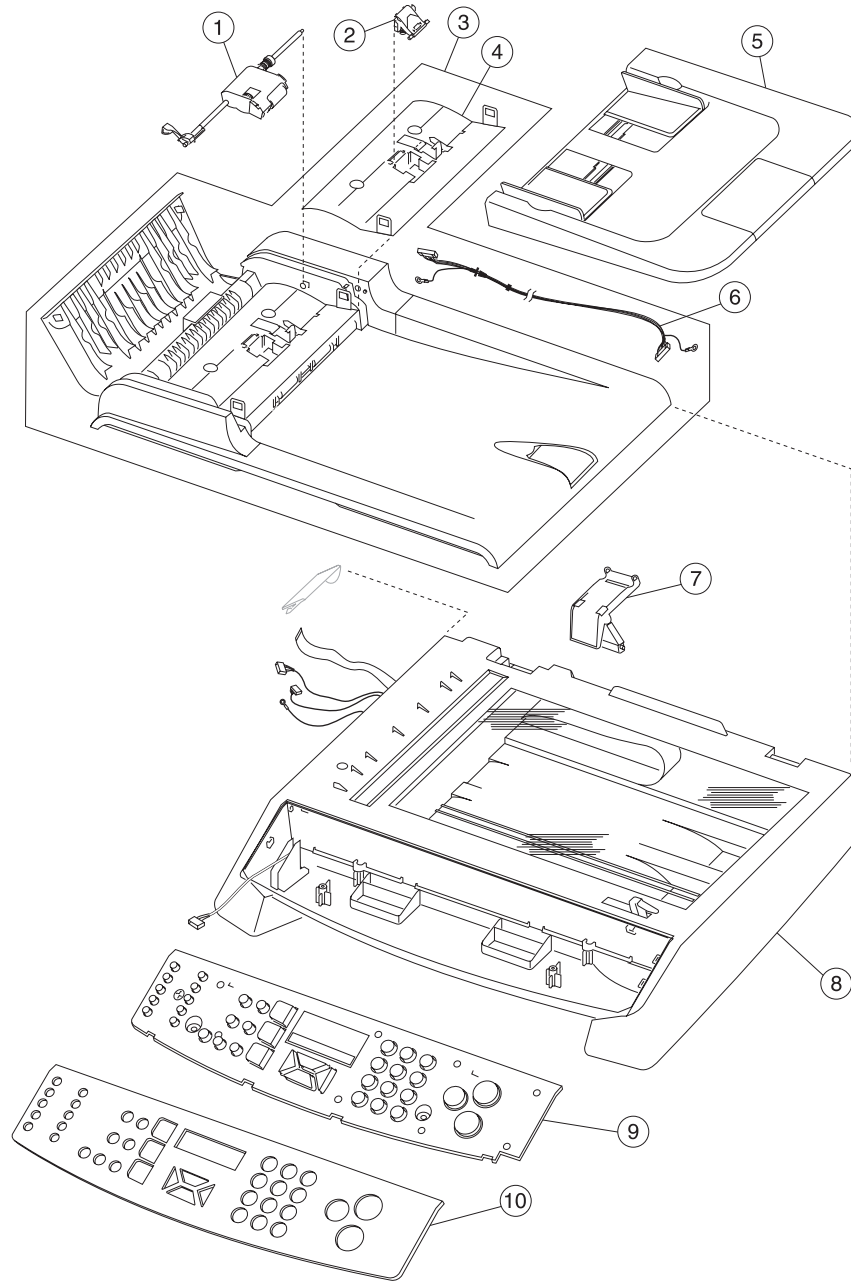

Assembly 3: Scanner Unit

index	P/N	Units	Description
3-1	40X4702	1	Assembly, pick roll
2	40X4703	1	Pad, ADF separator
3	40X4701	1	Assembly, ADF
4	40X4709	1	Cover, ADF mechanism
5	40X4708	1	Tray, ADF input
6	40X4714	1	Cable, ADF
7	40X4713	1	Guide, Cable
8	40X4700	1	Assembly, flatbed
9	40X4693	1	Panel, operator (X 500)
9	40X4695	1	Panel, operator (X 502)
10	40X4721	1	X 500 Bezel, operator panel
10	40X4722	1	X 502 Bezel, operator panel

Assembly 4: Front

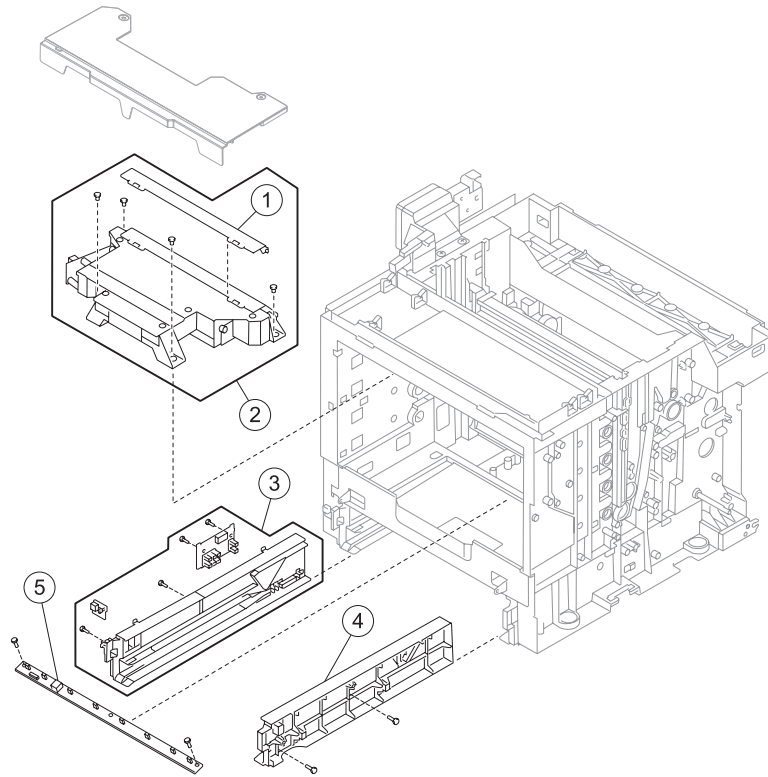

Assembly 4: Front

index	P/N	Units	Description
3-1	40X3441	1	Cover, laser unit assembly lens
2	40X3400	1	Laser unit assembly (printhead)
3	40X3431	1	Left tray guide assembly with cable (includes paper size sensor and temperature thermistor)
4	40X3401	1	Right tray guide
5	40X3416	1	Lamp, erase

Assembly 5: Right

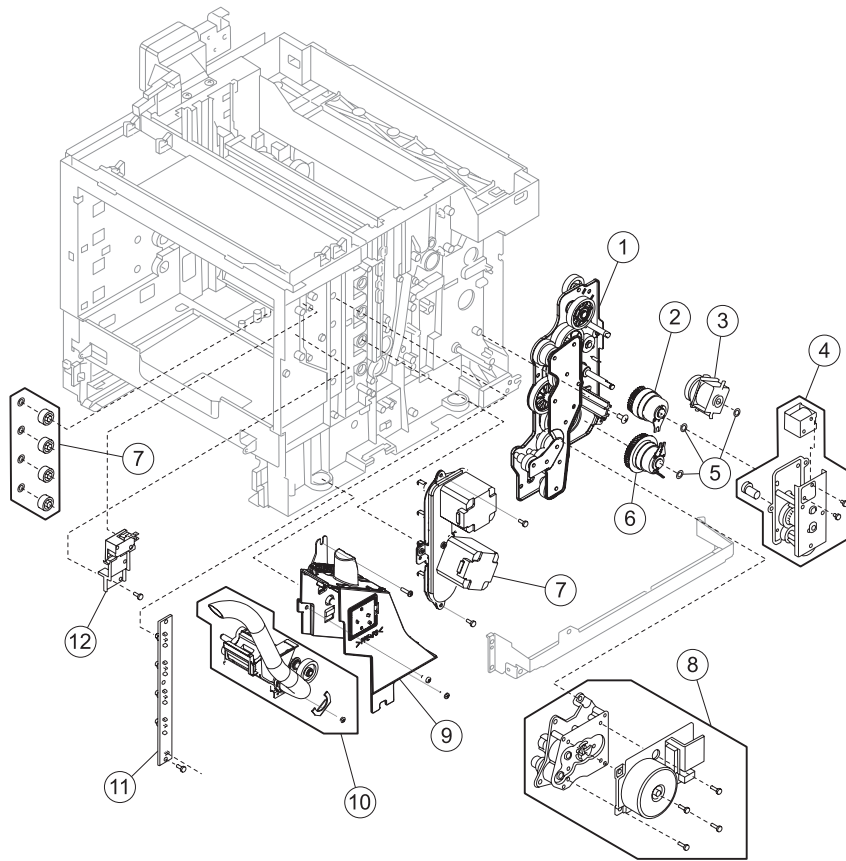

Assembly 5: Right

index	P/N	Units	Description
4-1	40X3395	1	Gear assembly, main drive
2	40X3391	1	Clutch, registration
3	40X3393	1	Clutch, transfer roller
4	40X3394	1	Clutch, cleaning roller
5	40X4718	1	Packet, parts
6	40X3390	1	Clutch, paper feed
7	40X3397	1	Drive assembly, developer
8	40X3389	1	Motor assembly, main
9	40X3398	1	Assembly, waste toner holder
10	40X3396	1	Waste toner feeder
11	40X3399	1	Sensor, toner, sender TPD (This is a two-piece sensor system. Ordering of this part number includes both the right and left side.)
12	40X3432	1	Assembly, interlock switch

Assembly 6: Rear

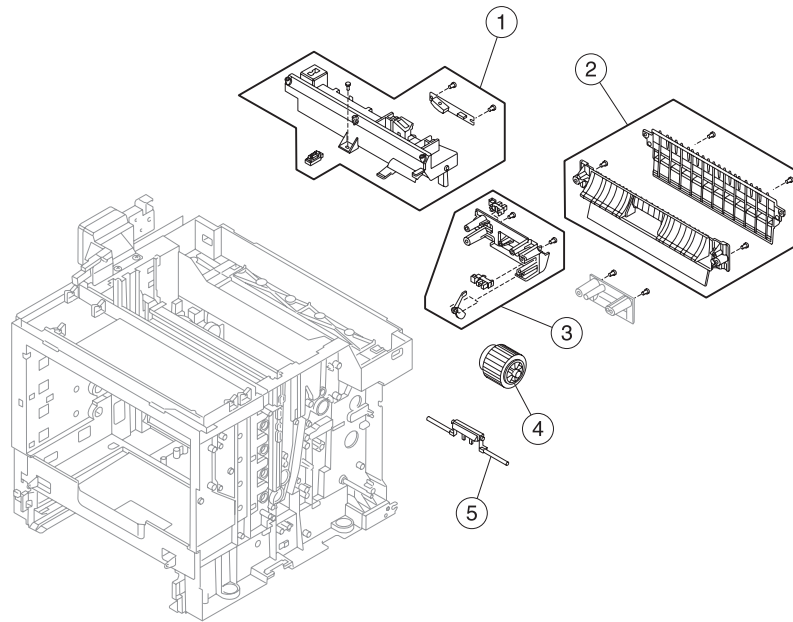

Assembly 6: Rear

index	P/N	Units	Description
5-1	40X3429	1	Assembly, bracket (includes marker sensor (transfer belt unit), toner density sensor)
2	40X3433	1	Paper guide assembly
3	40X3413	1	Paper guide (C) assembly with cable (includes registration sensor, tray empty sensor)
4	40X3414	1	Roller, paper feed
5	40X3415	1	Pad, separator

Assembly 7: Left

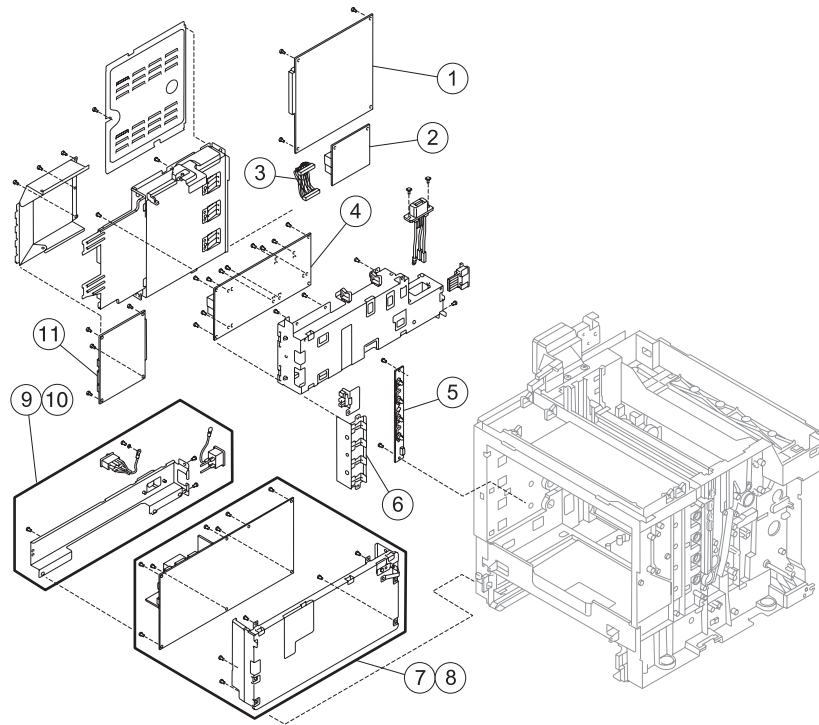

Assembly 7: Left

index	P/N	Units	Description
7-1	40X4696	1	Board, Network RIP
2	40X4711	1	Card, modem US
3	40X4715	1	Cable, modem
4	40X3405	1	Power supply, high voltage
5	40X3399	1	Sensor, toner, receiver TTR (This is a two-piece sensor system. Ordering of this part number includes both the right and left side.)
6	40X3410	1	Sensor, toner present
7	40X4704	1	Power supply, 110 V low voltage
8	40X4705	1	Power supply, 220 V low voltage
9	40X4719	1	Bracket, 110 V power supply
10	40X4720	1	Bracket, 220 V power supply
11	40X4689	1	Board, engine controller

Assembly 8: Top

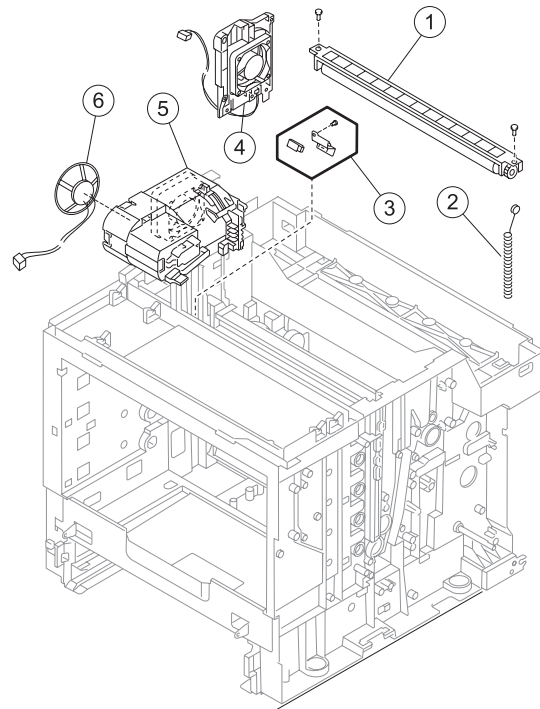

Assembly 8: Top

index	P/N	Units	Description
8-1	40X3402	1	Auger, waste toner
2	40X3403	1	Agitator, waste toner
3	40X3434	1	Assembly, marker sensor (OPC) (includes bracket)
4	40X4691	1	Assembly, fuser fan
5	40X4690	1	Fan, power supply (includes top cover interlock switch and rear cover assembly interlock switch)
6	40X4710	1	Speaker, modem

Assembly 9: Miscellaneous/Options

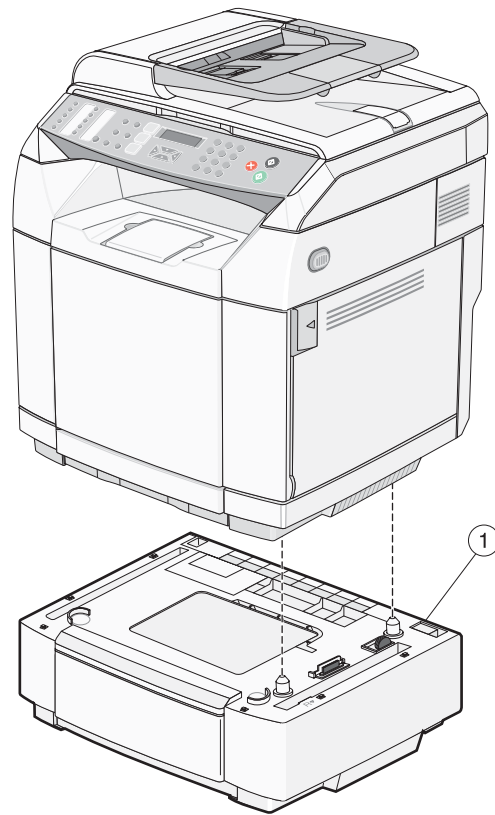

Assembly 9: Miscellaneous/Options

index	P/N	Units	Description
9-1	40X3421	1	Assembly, secondary paper feed
NS	40X4717	1	Parts packet, harness
NS	40X3442	1	Cable, 120V fuser
NS	40X3443	1	Cable, 240V fuser
NS	40X4718	1	Parts packet, screw
NS	7372640	1	Field relocation kit
NS	14D0403	1	Cable, USB, 2-meter

7100-XXX

Index

A

Accessing jam areas 3-23
 acronyms 1-17
 ADF mechanism cover
 removal 4-56
 ADF paper jams 3-30
 ADF unit
 removal 4-54

B

bracket assembly
 removal 4-30

C

cleaning roller clutch
 removal 4-25
 cleaning roller cover
 removal 4-4
 clearances 1-4
 clutch
 removal 4-27
 copy specifications 1-11
 CRU/FRU and supplies removals 4-4

D

developer drive assembly
 removal 4-22
 diagnostic aids 3-1
 diagnostic information
 printer service checks 2-14
 service error codes 2-3
 symptom tables 2-11
 user attendance messages 2-8
 user status messages 2-6

E

emulations 1-6
 engine controller board
 removal 4-34
 wiring diagram 5-9
 engine controller board connections 5-10
 environment 1-5
 erase lamp
 removal 4-20
 error codes
 service 2-3
 user attendance messages 2-8
 user status messages 2-6
 ESD-sensitive parts 4-2

F

fax specifications 1-11
 document sizes supported 1-12
 miscellaneous 1-12
 phone network connectivity 1-11

 scan resolutions 1-12
 flatbed assembly
 removal 4-50
 front cover assembly
 removal 4-12
 front door interlock switch
 removal 4-21
 fuser assembly
 removal 4-6
 fuser fan assembly
 removal 4-44

H

handling ESD-sensitive parts 4-2
 high voltage power supply
 removal 4-40
 HVPS cage
 removal 4-42

J

jam messages
 JAM-A tray, rear (tray 1) 3-24
 JAM-A tray, rear (tray 2) 3-26
 JAM-B rear 3-27
 JAM-C rear 3-29

L

Laser unit assembly
 removal 4-18
 left front cover
 removal 4-15
 left rear cover
 removal 4-16
 left tray guide assembly
 removal 4-43
 Lithium Information i-xviii
 Lithium Warning i-xviii
 locations 5-1
 circuit boards 5-5
 connections
 engine card 5-10
 modem card 5-18
 engine controller board 5-16
 fans and motors 5-6
 high voltage supply board 5-17
 low voltage power supply board 5-16
 printer
 front and rear view 5-1
 RIP board 5-15
 scanner 5-3
 sensors
 printer engine 5-4
 solenoids and clutches 5-7
 wiring diagram
 engine controller board 5-9

wiring diagram and cable harness reference 5-14
 low voltage power supply
 removal 4-41

M

main drive gear assembly
 removal 4-27
 main motor assembly
 removal 4-26
 maintenance approach 1-15
 inspection and cleaning procedure 1-15
 required tools 1-16
 serial number 1-16
 maintenance mode 3-4
 density tune up 3-8
 display info 3-4
 engine maintenance 3-6
 fax maintenance 3-6
 print reports 3-5
 scan maintenance 3-6
 marker sensor assembly
 removal 4-47
 media guidelines 1-13
 envelopes 1-13
 glossy 1-14
 labels 1-14
 paper 1-13
 sensing by source 1-14
 transparencies 1-13
 media input types and weights 1-8
 media sizes 1-9
 memory configuration 1-3
 messages
 user attendance 2-8
 user status 2-6
 models 1-1
 modem card
 removal 4-46
 modem speaker
 removal 4-44

O

operator panel
 alpha/numeric keys 3-1
 black start 3-1
 color start 3-1
 copy LEDs 3-1
 directory 3-2
 fax LEDs 3-1
 hook 3-2
 image quality 3-2
 LCD display 3-1
 menu keys 3-1
 reduce/enlarge 3-2
 lighter/darker 3-2
 re dial 3-2
 removal 4-58
 scan LEDs 3-1
 shift 3-2

speed dial 3-2
 stop/cleat 3-1
 output capacities 1-9

P

packaging and shipping dimensions 1-4
 paper and media specifications 1-7
 input and output configurations 1-7
 print area 1-7
 paper exit assembly
 removal 4-32
 paper feed roller
 removal 4-32
 paper guide (C) assembly
 removal 4-31
 paper guide assembly
 removal 4-31
 paper jam A1 3-24
 paper jam A2 3-26
 paper jam B rear 3-27
 paper jam C rear 3-29
 paper jam messages 2-11, 3-22
 ADF paper jam 3-30
 paper jam A1 3-24
 paper jam A2 3-26
 paper jam B rear 3-27
 paper jam C rear 3-29
 part number index 2-9
 photodeveloper
 handling precautions 4-3
 photodeveloper cartridge
 removal 4-8
 physical specifications and weight 1-3
 power and electrical specifications 1-4
 power supply fan
 removal 4-49
 preventive maintenance 6-1
 print engine specifications
 color balance 1-6
 emulations 1-6
 print resolution 1-6
 speed and performance 1-6
 time to first print 1-6
 printer theory of operation 3-9
 Printing the maintenance and configuration pages 3-3

R

rear cover assembly
 removal 4-14
 registration assembly
 removal 4-33
 removals
 ADF mechanism cover 4-56
 ADF unit 4-54
 bracket assembly 4-30
 cleaning roller clutch 4-25
 cleaning roller cover 4-4
 clutch 4-27
 covers 4-10

- developer drive assembly 4-22
 - engine controller board 4-34
 - erase lamp 4-20
 - flatbed assembly 4-50
 - front cover assembly 4-12
 - front door interlock switch 4-21
 - front door interlock switch with bracket 4-21
 - fuser assembly 4-6
 - fuser fan assembly 4-44
 - high voltage power supply (HVPS) 4-40
 - HVPS cage 4-42
 - laser unit assembly (printhead) 4-18
 - left cover 4-15
 - left rear cover 4-16
 - left side 4-34
 - left tray guide assembly 4-43
 - low voltage power supply (LVPS) 4-41
 - main drive gear assembly 4-27
 - main motor assembly 4-26
 - modem card 4-46
 - modem speaker 4-44
 - operator panel 4-58
 - paper exit assembly 4-32
 - paper exit unit 4-14
 - paper feed roller 4-32
 - paper guide (C) assembly 4-31
 - paper guide assembly 4-31
 - photodeveloper cartridge 4-8
 - power supply fan 4-49
 - rear 4-30
 - rear cover assembly 4-14
 - registration assembly 4-33
 - right cover 4-13
 - right side 4-21
 - scanner arm 4-53
 - second paper feed assembly 4-9
 - sensor assembly 4-47
 - system board 4-36
 - system board cage 4-39
 - toner present sensor 4-42
 - toner sensor (receiver) 4-43
 - toner sensor (sender) 4-24
 - top 4-47
 - top cover assembly 4-10
 - transfer belt cleaning roller 4-4
 - transfer belt unit 4-5
 - transfer roller 4-6
 - upper left rear cover 4-17
 - upper right rear cover 4-17
 - waste toner agitator 4-48
 - waste toner agitator removal 4-48
 - waste toner auger 4-48
 - waste toner bottle 4-7
 - waste toner bottle holder 4-22
 - waste toner feeder 4-28
 - repair information 4-1
 - required tools 1-16
 - right cover
 - removal 4-13
 - roller spacing 2-69
- ## S
- safety information i-xv
 - scan specifications 1-10
 - scanner arm
 - removal 4-53
 - Scanner calibration and registration 3-3
 - secondary paper feed assembly
 - removal 4-9
 - sensing by source 1-14
 - serial number 1-16
 - service checks
 - ADF paperfeed 2-42
 - ADF streak 2-41
 - black page 2-41
 - cover open 2-35
 - developer drive assembly 2-16
 - erase lamp 2-21
 - flatbed 2-41
 - fuser assembly 2-24
 - fuser fan 2-22
 - fuser thermistor 2-24
 - high voltage power supply 2-23
 - HVPS connection 2-25
 - laser unit assembly 2-25
 - lower feed unit (paper tray 2) 2-28
 - lower voltage power supply 2-23
 - main motor 2-14
 - missing fuser 2-36
 - missing photodeveloper cartridge 2-33
 - missing toner cartridge 2-32
 - modem / fax card 2-43
 - network 2-40
 - OPC belt (photodeveloper) cartridge drive 2-36
 - OPC belt marker sensor 2-20
 - operator panel 2-40
 - paper feed 2-44
 - paper feed clutch 2-19
 - paper size sensing 2-37
 - paper tray missing 2-30
 - power supply fan 2-22
 - print quality 2-45
 - back stain 2-46
 - background 2-45
 - banding 2-47
 - black line 2-48
 - color misregistration 2-49
 - insufficient fusing 2-50
 - insufficient gloss 2-51
 - jitter 2-52
 - missing image at edge 2-53
 - mixed color image 2-54
 - mottle 2-55
 - residual image 2-56
 - ribbing 2-57
 - smear 2-58
 - toner drop 2-59
 - uneven density (right and left) 2-68
 - vertical line 2-60

- vertical staggering image 2-61
- vertical white band 2-62
- white band 2-63
- white line I 2-64
- white line II 2-64
- white print 2-66
- white spot / black spot 2-65
- wrinkle / image migration 2-67
- printer 2-14
- printer no power 2-38
- printer paper feed 2-44
- registration clutch 2-19
- toner empty sensor (receiver-TTR) 2-27
- toner empty sensor (sender-TPD) 2-26
- toner feed 2-39
- toner low / empty 2-31
- transfer belt cleaning roller clutch 2-18
- transfer belt unit 2-17
- transfer roller clutch 2-18
- transfer roller missing 2-34
- tray empty 2-29
- USB 2-40
- waste toner bottle 2-31
- waste toner feed 2-39
- service error codes 2-3
- Setting the country code 3-3
- spacing table 2-69
- specifications 1-2
- supported operating systems 1-2
- symptom tables
 - MFP 2-11
 - print quality 2-13
- system board
 - removal 4-36
- system board cage
 - removal 4-39

T

- theory of operation
 - ep basic 3-9
 - printer components 3-19
 - X500 paper path components 3-20
 - X500 steps in detail 3-11
 - X500 summary 3-10
- time to first print 1-6
- toner present sensor
 - removal 4-42
- toner sensor(sender)
 - removal 4-24
- toner sensor (receiver)
 - removal 4-43
- top cover assembly
 - removal 4-10
- transfer belt cleaning roller
 - removal 4-4
- transfer belt unit
 - removal 4-5
- transfer roller
 - removal 4-6

U

- Understanding the operator panel 3-1
- upper right rear cover
 - removal 4-17
- upper left rear cover
 - removal 4-17

W

- waste toner agitator
 - removal 4-48
- waste toner auger
 - removal 4-48
- waste toner bottle
 - removal 4-7, 4-22
- waste toner feeder
 - removal 4-28

Part number index

P/N	Description	page
14D0403	Cable, USB, 2-meter	7-19
40X0273	Power cord, HV, Chile	7-3
40X0274	Power cord, HV, Switzerland French, Switzerland German, Switzerland Italian	7-3
40X0275	Power cord, HV, Israel	7-3
40X0276	Power cord, HV, South Africa	7-3
40X0278	Power cord, HV, Austria, Belgium, Euro English, Finland, France, Germany, Greece, Netherlands, Norway, Poland, Portugal, Russia, Slovakia/Czech/Hungary, Spain, Sweden, Turkey	7-3
40X0279	Power cord, HV, Denmark	7-3
40X0286	Power cord, HV, UK, Ireland	7-3
40X0287	Power cord, HV, Italy	7-3
40X0297	Power cord, USA	7-3
40X0301	Power cord, HV, Argentina	7-3
40X1766	Power cord, LV, USA, APG, Bolivia, Canada, Columbia, Costa Rica, Ecuador, El Salvador, Guatemala, Honduras, Mexico, Nicaragua, Panama, Peru, Venezuela	7-3
40X1767	Power cord, HV, Brazil	7-3
40X3382	Roller, cleaning	7-3
40X3383	Cover, cleaning roller	7-3
40X3385	Cover, right	7-5
40X3387	Cover, inner front	7-5
40X3388	Cover, front	7-5
40X3389	Motor assembly, main	7-11
40X3390	Clutch, paper feed	7-11
40X3391	Clutch, registration	7-11
40X3393	Clutch, transfer roller	7-11
40X3394	Clutch, cleaning roller	7-11
40X3395	Gear assembly, main drive	7-11
40X3396	Waste toner feeder	7-11
40X3397	Drive assembly, developer	7-11
40X3398	Assembly, waste toner holder	7-11
40X3399	Sensor, toner, receiver TTR (This is a two-piece sensor system. Ordering of this part number includes both the right and left side.)	7-15
40X3399	Sensor, toner, sender TPD (This is a two-piece sensor system. Ordering of this part number includes both the right and left side.)	7-11
40X3400	Laser unit assembly (printhead)	7-9
40X3401	Right tray guide	7-9
40X3402	Auger, waste toner	7-17
40X3403	Agitator, waste toner	7-17
40X3405	Power supply, high voltage	7-15
40X3410	Sensor, toner present	7-15
40X3412	Transfer unit	7-3
40X3413	Paper guide (C) assembly (includes registration sensor, tray empty sensor)	7-13
40X3414	Roller, paper feed	7-13
40X3415	Pad, separator	7-13
40X3416	Lamp, erase	7-9
40X3418	Transfer roller assembly	7-3
40X3420	Packet, parts	7-5
40X3421	Assembly, secondary paper feed	7-19
40X3428	Assembly, paper exit (contains fuser exit sensor and flag)	7-5
40X3429	Assembly, bracket (includes marker sensor (transfer belt unit), toner density sensor)	7-13
40X3430	Assembly, registration	7-5
40X3431	Left tray guide assembly (includes paper size sensor and temperature thermistor)	7-9
40X3432	Assembly, interlock switch	7-11
40X3433	Paper guide assembly	7-13
40X3434	Assembly, marker sensor (OPC) (includes bracket)	7-17

7100-XXX

40X3441 Cover, laser unit assembly lens ----- 7-9
40X3442 Parts packet, harness ----- 7-19
40X3443 Parts packet, harness ----- 7-19
40X4686 Cover assembly, top ----- 7-5
40X4687 Cover, front left ----- 7-5
40X4688 Cover, rear left ----- 7-5
40X4689 Board, engine controller ----- 7-15
40X4690 Fan, power supply (includes top cover and rear cover assembly interlock switches) ----- 7-17
40X4691 Assembly, fuser fan ----- 7-17
40X4692 Rear cover assembly ----- 7-5
40X4693 Panel, operator(X500) ----- 7-7
40X4694 Paper tray, universal ----- 7-3
40X4695 Panel, operator(X502) ----- 7-7
40X4696 Board, Network RIP (US) ----- 7-15
40X4698 Cover, top left ----- 7-5
40X4699 Cover, top right ----- 7-5
40X4700 Assembly, flatbed ----- 7-7
40X4701 Assembly, ADF ----- 7-7
40X4702 Assembly, ADF separator roll ----- 7-3
40X4702 Assembly, pick roll ----- 7-7
40X4703 Pad, ADF separator ----- 7-3, 7-7
40X4704 Power supply, 110 V low voltage ----- 7-15
40X4705 Power supply, 220 V low voltage ----- 7-15
40X4706 Arm, right/left scanner ----- 7-5
40X4708 Tray, ADF input ----- 7-7
40X4710 Speaker, modem ----- 7-17
40X4711 Card, modem US ----- 7-15
40X4713 Guide, cable ----- 7-7
40X4714 Cable, ADF ----- 7-7
40X4715 Cable, modem ----- 7-15
40X4716 Cover, legal extender ----- 7-3, 7-5
40X4717 Cover, ADF mechanism ----- 7-7
40X4717 Packet, parts ----- 7-11
40X4717 Parts packet, harness ----- 7-19
40X4718 Parts packet, screw ----- 7-19
40X4719 Power supply, 110 V low voltage ----- 7-15
40X4720 Power supply, 220 V low voltage ----- 7-15
40X4721 Bezel operator panel(X500) ----- 7-7
40X4722 Bezel, operator panel(X502) ----- 7-7
7372640 Field relocation kit ----- 7-19