



Service Manual

**Lexmark™ X734de, X736de,
X738de, X738dte MFP**

7526

- ***Table of contents***
- ***Start diagnostics***
- ***Safety and notices***
- ***Trademarks***
- ***Index***

LEXMARK™

Lexmark and Lexmark with diamond design are trademarks of Lexmark International, Inc., registered in the United States and/or other countries.

Edition: June 9, 2009

The following paragraph does not apply to any country where such provisions are inconsistent with local law: LEXMARK INTERNATIONAL, INC. PROVIDES THIS PUBLICATION "AS IS" WITHOUT WARRANTY OF ANY KIND, EITHER EXPRESS OR IMPLIED, INCLUDING, BUT NOT LIMITED TO, THE IMPLIED WARRANTIES OF MERCHANTABILITY OR FITNESS FOR A PARTICULAR PURPOSE. Some states do not allow disclaimer of express or implied warranties in certain transactions; therefore, this statement may not apply to you.

This publication could include technical inaccuracies or typographical errors. Changes are periodically made to the information herein; these changes will be incorporated in later editions. Improvements or changes in the products or the programs described may be made at any time.

Comments may be addressed to Lexmark International, Inc., Department D22A/032-2, 740 West New Circle Road, Lexington, Kentucky 40550, U.S.A or e-mail at ServiceInfoAndTraining@Lexmark.com. Lexmark may use or distribute any of the information you supply in any way it believes appropriate without incurring any obligation to you.

References in this publication to products, programs, or services do not imply that the manufacturer intends to make these available in all countries in which it operates. Any reference to a product, program, or service is not intended to state or imply that only that product, program, or service may be used. Any functionally equivalent product, program, or service that does not infringe any existing intellectual property right may be used instead. Evaluation and verification of operation in conjunction with other products, programs, or services, except those expressly designated by the manufacturer, are the user's responsibility.

Lexmark, Lexmark with diamond design, and MarkNet are trademarks of Lexmark International, Inc., registered in the United States and/or other countries.

PrintCryption is a trademark of Lexmark International, Inc.

PCL® is a registered trademark of the Hewlett-Packard Company.

All other trademarks are the property of their respective owners.

**© 2009 Lexmark International, Inc.
All rights reserved.**

UNITED STATES GOVERNMENT RIGHTS

This software and any accompanying documentation provided under this agreement are commercial computer software and documentation developed exclusively at private expense.

Table of contents

Notices and safety information	xi
Laser notice	xi
Lithium warning	xvii
Safety information	xvii
Preface	XX
Conventions	xx
General information	1-1
Models	1-1
Options and features	1-1
Media options	1-1
Memory options	1-2
Printer and scanner specifications	1-2
Dimensions	1-2
Clearances	1-3
Multiple function printer specifications	1-3
Memory	1-4
Resolution	1-4
Data streams	1-4
Environment specifications	1-5
Electrical and power specifications	1-6
Acoustic specifications	1-7
Media specifications	1-8
Input and output capacities	1-10
Input and output sizes and types	1-11
Paper guidelines	1-13
Tools required for service	1-15
Acronyms	1-15
Diagnostic information	2-1
Start	2-1
Operator panel and menus	2-2
Operator panel	2-2
Buttons, icons, and light description	2-2
Administrative Menu	2-4
Power-on self test (POST) sequence	2-5
Symptom tables	2-6
Printer symptom table	2-6
Print quality symptom table	2-6
User status and attendance messages	2-7
Error codes and messages	2-17
Service checks	2-40
110.xx—Mirror motor service check	2-40
111.xx, 112.xx, 113.xx, and 114.xx—Printhead error service check	2-41
120.xx—Fuser error service check	2-42
140.xx, 920.02—Autocomp (tray 1) motor error service check	2-46
142.xx, 906.01–906.04—Motor (fuser) error service check	2-47
143.xx—Motor (EP drive assembly top cartridge) error service check	2-48
144.xx—Motor (EP drive assembly middle cartridge) error service check	2-50
145.xx—Motor (EP drive assembly bottom cartridge) error service check	2-51
146.xx, 148.xx—Motor (MPF/duplex) error service check	2-53
147.xx, 920.01—Motor (aligner) error service check	2-55
155.xx—Cam motor error service check	2-56
156.xx—COD (Color On Demand) motor error service check	2-58

160.xx, 161.xx—Motor Error (option tray 2) service check	2-60
162.xx, 163.xx—Motor (option tray 3) error service check	2-61
164.xx, 165.xx—Motor Error (option tray 4) service check	2-62
166.xx, 167.xx—Motor Error (option tray 5) service check	2-63
168.xx—Motor (HCIT elevator) error service check	2-64
200.11, 250.03—Paper Jam error service check	2-65
201.06, 201.31—Paper Jam error service check	2-66
203.09—Paper Jam error service check	2-69
230.03, 230.05—Paper Jam error service check	2-71
242.02—Paper Jam error service check	2-73
242.03, 242.11—Paper Jam service check	2-74
242.05—Paper Jam service check	2-75
242.10—Paper Jam service check	2-76
242.17—Paper Jam service check	2-77
242.26—Paper Jam service check	2-78
242.27—Paper Jam service check	2-78
242.29—Paper Jam service check	2-79
243.02—Paper Jam service check	2-79
243.03, 243.11—Paper Jam service check	2-81
243.05—Paper Jam service check	2-82
243.10—Paper Jam service check	2-83
243.17—Paper Jam service check	2-84
243.26—Paper Jam service check	2-85
243.27—Paper Jam service check	2-85
243.29—Paper Jam service check	2-85
244.02—Paper Jam service check	2-86
244.03, 244.11—Paper Jam service check	2-87
244.05—Paper Jam service check	2-88
244.10—Paper Jam service check	2-89
244.17—Paper Jam service check	2-90
244.26—Paper Jam service check	2-91
244.27—Paper Jam service check	2-91
244.29—Paper Jam service check	2-91
245.02—Paper Jam service check	2-92
245.03, 245.11—Paper Jam service check	2-93
245.05—Paper Jam service check	2-94
245.10—Paper Jam service check	2-95
245.17—Paper Jam service check	2-96
245.29—Paper Jam service check	2-97
290.01, 290.02—Scanner ADF pickup/feed jam service check	2-97
292.00—Scanner ADF cover open jam service check	2-98
293.02—Flatbed cover open jam service check	2-101
842.xx—Scanner Failure—Communication failure service check	2-101
843.00—Scanner Failure—Carriage failed to move service check	2-102
843.01, 843.02—Scanner Failure service check	2-102
844.xx—Scanner Error—scan module output level error service check	2-103
845.xx—Scanner Failure service check	2-103
846.xx—Front calibration strip error service check	2-104
900.05—Transfer module error service check	2-104
902.59—Engine software error, NVRAM MGR problem	2-105
920.03, 920.25—Transfer Module Missing error service check	2-106
920.04—POST error service check	2-107
920.05—POST—printhead motor not connected error service check	2-108
920.07—POST error service check	2-109
920.09—POST—Four toner sensor not connected error service check	2-110
920.10—POST—Three toner sensors not connected error service check	2-111
920.11—POST—Two toner sensors not connected error service check	2-112
920.12—POST—One sensor not connected error service check	2-113
920.13—POST error service check	2-113

920.14—POST—Cartridge motor 2 not connected error service check	2-115
920.15, 920.20—POST—Bad transfer module NVRAM data error service check	2-116
920.16—POST error service check	2-117
920.17—POST error service check	2-118
920.18—POST—Cartridge motor 3 not connected error service check	2-119
920.19—POST—Transfer module stepper motor not connected error service check	2-120
920.21—POST error service check	2-122
920.23—POST error service check	2-124
920.26—POST service check	2-125
920.27, 920.28, 920.29—POST (power on self test) service check	2-126
925.01, 925.03, 925.05—Fan error service check	2-126
925.02, 925.04, 925.06—Blower error service check	2-127
945.xx, 947.xx—Transfer roll error service check	2-128
950.00—950.29—EPROM mismatch failure	2-130
956.xx—System board failure service check	2-131
5 V interlock switch service check	2-131
24 V interlock switch removal	2-133
ADF exit sensor service check	2-134
ADF input sensor service check	2-135
ADF jam sensor service check	2-136
ADF skew sensor service check	2-137
ADF scanning sensor service check	2-138
Bubble sensor service check	2-138
Dead printer service check	2-140
Exit sensor service check	2-141
Input sensor service check	2-143
Networking service check	2-144
Operator panel service check	2-145
Print quality service check	2-147
Diagnostic aids	3-1
Accessing test and diagnostic procedure menus	3-1
Diagnostics menu	3-3
Diagnostics menu structure	3-3
Available tests	3-3
Registration	3-6
Scanner Tests	3-9
Alignment Menu	3-11
Motor tests	3-12
Print Tests	3-13
Hardware Tests	3-15
Duplex Tests	3-18
Sensor Tests	3-21
Printhead Tests	3-22
Device Tests	3-22
Printer Setup	3-23
EP Setup	3-26
Reports	3-27
Event Log	3-28
EXIT DIAGNOSTICS	3-29
Configuration menu (CONFIG MENU)	3-30
Available tests	3-30
Reset Fuser Count	3-31
USB Scan to Local	3-31
Color Lock Out	3-32
Prt Quality Pages	3-32
Reports	3-32
Color Trapping	3-33
Size Sensing	3-33

Panel Menus	3-34
PPDS Emulation	3-34
Download Emuls	3-34
Factory Defaults	3-35
Energy Conserve	3-35
NumPad Job Assist	3-36
Min Copy Memory	3-36
Format Fax Storage	3-36
Fax Storage Location	3-37
ADF Edge Erase	3-37
FB Edge Erase	3-37
Scanner Manual Registration	3-38
Disable Scanner	3-40
Automatic Color Adjust	3-40
Auto Align Adj	3-40
Enforce Color Order	3-41
Color Alignment	3-41
Color Adj State	3-41
Motor Calibration	3-42
Paper Prompts	3-42
Envelope Prompts	3-42
Action for Prompts	3-43
Duplex Gloss	3-43
Jobs on Disk	3-43
Disk Encryption	3-44
Wipe Disk	3-45
Duplex Gloss	3-45
Font Sharpening	3-46
Require Standby	3-46
LES Applications	3-46
Key Repeat Initial Delay	3-46
Key Repeat Rate	3-46
Clear Custom Status	3-47
Pel Blurring	3-47
USB Speed	3-47
Exit Config Menu	3-47
Service Engineer (SE) Menu	3-48
Front cover locked in place	3-49
Printhead verification	3-52
Paper Jams	3-57
Error jam locations	3-57
Clearing jams	3-59
Understanding jam messages	3-59
Repair information	4-1
Safety information	4-1
Removal and cleaning precautions	4-1
Handling ESD-sensitive parts	4-2
Handling the photoconductor unit	4-2
Transportation/storage	4-2
Handling	4-2
Parts not to be touched	4-2
Screw and retainer identification table	4-3
Adjustments	4-9
Printhead alignment	4-9
Printer removal procedures	4-19
Precautions to take before maintenance work	4-19
Multifunction printer removals	4-20
Front access cover assembly removal	4-20

Left cover removal	4-23
Left door cover removal	4-25
Operator panel assembly removal	4-26
Operator panel bezel removal	4-31
Operator panel buttons removal	4-32
Output bin extension cover removal	4-36
Rear cover removal	4-37
Rear frame cover removal	4-38
Right cover removal	4-39
Top access cover assembly removal	4-41
Top cover assembly removal	4-45
5 V interlock switch cable removal	4-48
24 V interlock switch removal	4-50
Bin full sensor assembly removal	4-52
Cartridge cooling fan removal	4-53
Cartridge motor 1/fuser cable removal	4-55
Cartridge motor 2/3 cable removal	4-57
Color on demand assembly removal	4-59
Contact springs removal	4-63
Cooling fan removal	4-65
Cooling fan filter removal	4-66
Duplex reference edge guide assembly removal	4-67
Electrophotographic (EP) drive assembly removal	4-70
Fax modem removal	4-82
Front door assembly removal	4-83
Front door assembly front cable (left) removal	4-86
Front door assembly front cable (right) removal	4-90
Fuser assembly removal	4-94
Fuser AC cable removal	4-95
Fuser DC cable removal	4-97
Hard drive assembly removal	4-98
High-voltage power supply (HVPS) removal	4-100
High-voltage power supply (HVPS) cable removal	4-102
Left bellcrank assembly removal	4-103
Low-voltage power supply (LVPS) removal	4-104
Motor driver cable removal	4-106
Motor driver card removal	4-107
Multipurpose feeder (MPF)/duplex gear and housing removal	4-108
Multipurpose feeder (MPF)/duplex motor assembly removal	4-110
Multipurpose feeder (MPF)/duplex motor cable removal	4-114
Option cable removal	4-115
Paper pick mechanism assembly removal	4-117
Photoconductor unit removal	4-124
Pick tires removal and replacement	4-125
Printer pad removal	4-126
Printhead removal, installation, and adjustment	4-128
Right bellcrank assembly removal	4-147
System board removal	4-148
System board support shield removal	4-154
Toner level sensor removal	4-157
Top access cover links removal	4-159
Top access cover sensor removal	4-160
Top cover camshaft assembly removal	4-162
Transfer module removal	4-168
Transport cable removal	4-170
Transport motor cable removal	4-173
UICC card removal	4-174
UICC cable removal	4-178
USB connector cable removal (front panel)	4-182

Waste toner assembly removal	4-186
Wireless network antenna removal	4-187
Wireless network card removal	4-188
Scanner flatbed and automatic document feeder (ADF)	4-190
ADF front cover removal	4-190
ADF front side cover removal	4-192
ADF handle cover removal	4-193
ADF motor side cover removal	4-194
ADF upper case cover removal	4-197
Flatbed cave LED card and cover removal	4-199
Flatbed with glass cover removal	4-201
Input tray removal	4-204
Scanner front cover removal	4-205
Scanner left cover removal	4-206
Scanner rear cover removal	4-207
Scanner right cover removal	4-208
ADF removal (entire)	4-210
ADF case assembly removal	4-213
ADF closed cover flag removal	4-215
ADF exit sensor (with cable) removal	4-216
ADF hinge (left and right) removal	4-218
ADF motor gear train removal	4-219
ADF paper stop removal	4-223
ADF pick pad removal	4-223
ADF pick pad spring removal	4-224
ADF pick roller assembly removal	4-224
ADF pressure plate cover removal	4-226
ADF separator pad removal	4-228
Carriage transport belt with clip removal	4-229
ESD brush removal	4-230
Flatbed air filter removal	4-231
Flatbed CCD lamp assembly removal	4-232
Flatbed CCD carrier module removal	4-235
Flatbed cooling fan removal	4-239
Flatbed scanner removal	4-240
Paper present LED card removal	4-243
Scanner ICC card removal	4-244
Scanner ICC cable removal	4-245
Scanner MDC card removal	4-247
High-capacity input tray (HCIT) option removals	4-250
HCIT media tray assembly removal	4-250
HCIT front tray cover removal	4-251
HCIT rear cover removal	4-252
HCIT right cover removal	4-253
HCIT left cover removal	4-254
Feed with bushing roller removal	4-255
HCIT controller board assembly removal	4-256
HCIT drawer slide assembly removal	4-257
HCIT elevator motor with sensor removal	4-257
HCIT pick tires removal	4-259
HCIT slide assembly with spring removal	4-260
Photointerrupter sensor with cable assembly removal	4-262
Top plate assembly removal	4-264

Connector locations	5-1
Locations—printer base	5-1
Connectors	5-2
System board	5-2
Preventive maintenance	6-1
Safety inspection guide	6-1
Lubrication specifications	6-1
Maintenance	6-2
Cleaning the scanner glass	6-2
Cleaning the ADF parts	6-3
Cleaning the printhead lenses	6-5
Spare ADF supplies	6-5
Parts catalog	7-1
How to use this parts catalog	7-1
Assembly 1: Covers—printer	7-2
Assembly 2: Front	7-4
Assembly 3: Right	7-6
Assembly 4: Rear	7-8
Assembly 5: Left	7-10
Assembly 6: Top	7-12
Assembly 7: Cable parts packet	7-13
Assembly 8: Covers—scanner	7-14
Assembly 9: Automatic document feeder (ADF)	7-16
Assembly 10: Flatbed scanner	7-18
Assembly 11: Optional 550-sheet media drawer and tray	7-20
Assembly 12: Optional special media tray assembly	7-21
Assembly 13: Optional high-capacity input option (HCIT)	7-22
Assembly 14: Options and features	7-24
Index	I-1
Part number index	I-9

Notices and safety information

Laser notice

The printer is certified in the U.S. to conform to the requirements of DHHS 21 CFR Subchapter J for Class I (1) laser products, and elsewhere is certified as a Class I laser product conforming to the requirements of IEC 60825-1.

Class I laser products are not considered to be hazardous. The printer contains internally a Class IIIb (3b) laser that is nominally a 5 milliwatt gallium arsenide laser operating in the wavelength region of 770-795 nanometers. The laser system and printer are designed so there is never any human access to laser radiation above a Class I level during normal operation, user maintenance, or prescribed service condition.

Laser

Der Drucker erfüllt gemäß amtlicher Bestätigung der USA die Anforderungen der Bestimmung DHHS (Department of Health and Human Services) 21 CFR Teil J für Laserprodukte der Klasse I (1). In anderen Ländern gilt der Drucker als Laserprodukt der Klasse I, der die Anforderungen der IEC (International Electrotechnical Commission) 60825-1 gemäß amtlicher Bestätigung erfüllt.

Laserprodukte der Klasse I gelten als unschädlich. Im Inneren des Druckers befindet sich ein Laser der Klasse IIIb (3b), bei dem es sich um einen Galliumarsenlaser mit 5 Milliwatt handelt, der Wellen der Länge 770-795 Nanometer ausstrahlt. Das Lasersystem und der Drucker sind so konzipiert, daß im Normalbetrieb, bei der Wartung durch den Benutzer oder bei ordnungsgemäßer Wartung durch den Kundendienst Laserbestrahlung, die Klasse I übersteigen würde, Menschen keinesfalls erreicht.

Avis relatif à l'utilisation de laser

Pour les Etats-Unis : cette imprimante est certifiée conforme aux provisions DHHS 21 CFR alinéa J concernant les produits laser de Classe I (1). Pour les autres pays : cette imprimante répond aux normes IEC 60825-1 relatives aux produits laser de Classe I.

Les produits laser de Classe I sont considérés comme des produits non dangereux. Cette imprimante est équipée d'un laser de Classe IIIb (3b) (arséniure de gallium d'une puissance nominale de 5 milliwatts) émettant sur des longueurs d'onde comprises entre 770 et 795 nanomètres. L'imprimante et son système laser sont conçus pour impossible, dans des conditions normales d'utilisation, d'entretien par l'utilisateur ou de révision, l'exposition à des rayonnements laser supérieurs à des rayonnements de Classe I.

Avvertenze sui prodotti laser

Questa stampante è certificata negli Stati Uniti per essere conforme ai requisiti del DHHS 21 CFR Sottocapitolo J per i prodotti laser di classe 1 ed è certificata negli altri Paesi come prodotto laser di classe 1 conforme ai requisiti della norma CEI 60825-1.

I prodotti laser di classe non sono considerati pericolosi. La stampante contiene al suo interno un laser di classe IIIb (3b) all'arseniuro di gallio della potenza di 5mW che opera sulla lunghezza d'onda compresa tra 770 e 795 nanometri. Il sistema laser e la stampante sono stati progettati in modo tale che le persone a contatto con la stampante, durante il normale funzionamento, le operazioni di servizio o quelle di assistenza tecnica, non ricevano radiazioni laser superiori al livello della classe 1.

Avisos sobre el láser

Se certifica que, en los EE.UU., esta impresora cumple los requisitos para los productos láser de Clase I (1) establecidos en el subcapítulo J de la norma CFR 21 del DHHS (Departamento de Sanidad y Servicios) y, en los demás países, reúne todas las condiciones expuestas en la norma IEC 60825-1 para productos láser de Clase I (1).

Los productos láser de Clase I no se consideran peligrosos. La impresora contiene en su interior un láser de Clase IIIb (3b) de arseniuro de galio de funcionamiento nominal a 5 milivatios en una longitud de onda de 770 a 795 nanómetros. El sistema láser y la impresora están diseñados de forma que ninguna persona pueda verse afectada por ningún tipo de radiación láser superior al nivel de la Clase I durante su uso normal, el mantenimiento realizado por el usuario o cualquier otra situación de servicio técnico.

Declaração sobre Laser

A impressora está certificada nos E.U.A. em conformidade com os requisitos da regulamentação DHHS 21 CFR Subcapítulo J para a Classe I (1) de produtos laser. Em outros locais, está certificada como um produto laser da Classe I, em conformidade com os requisitos da norma IEC 60825-1.

Os produtos laser da Classe I não são considerados perigosos. Internamente, a impressora contém um produto laser da Classe IIIb (3b), designado laser de arseneto de potássio, de 5 milliwatts, operando numa faixa de comprimento de onda entre 770 e 795 nanómetros. O sistema e a impressora laser foram concebidos de forma a nunca existir qualquer possibilidade de acesso humano a radiação laser superior a um nível de Classe I durante a operação normal, a manutenção feita pelo utilizador ou condições de assistência prescritas.

Laserinformatie

De printer voldoet aan de eisen die gesteld worden aan een laserprodukt van klasse I. Voor de Verenigde Staten zijn deze eisen vastgelegd in DHHS 21 CFR Subchapter J, voor andere landen in IEC 60825-1.

Laserprodukten van klasse I worden niet als ongevaarlijk aangemerkt. De printer is voorzien van een laser van klasse IIIb (3b), dat wil zeggen een gallium arsenide-laser van 5 milliwatt met een golflengte van 770-795 nanometer. Het lasergedeelte en de printer zijn zo ontworpen dat bij normaal gebruik, bij onderhoud of reparatie conform de voorschriften, nooit blootstelling mogelijk is aan laserstraling boven een niveau zoals voorgeschreven is voor klasse 1.

Lasermeddelelse

Printeren er godkendt som et Klasse I-laserprodukt, i overensstemmelse med kravene i IEC 60825-1.

Klasse I-laserprodukter betragtes ikke som farlige. Printeren indeholder internt en Klasse IIIB (3b)-laser, der nominelt er en 5 milliwatt galliumarsenid laser, som arbejder på bølgelængdeområdet 770-795 nanometer. Lasersystemet og printeren er udformet således, at mennesker aldrig udsættes for en laserstråling over Klasse I-niveau ved normal drift, brugervedligeholdelse eller obligatoriske servicebetingelser.

Laserilmoitus

Tämä tulostin on sertifioitu Yhdysvalloissa DHHS 21 CFR Subchapter J -standardin mukaiseksi luokan I (1) - lasertuotteeksi ja muualla IEC 60825-1 -standardin mukaiseksi luokan I lasertuotteeksi.

Luokan I lasertuotteita ei pidetä haitallisina. Tulostimen sisällä on luokan IIIb (3b) laser, joka on nimellisteholtaan 5 mW:n galliumarsenidilaser ja toimii 770 - 795 nanometrin aallonpituuksilla. Laserjärjestelmä ja tulostin ovat rakenteeltaan sellaisia, että käyttäjä ei joudu alttiiksi luokkaa 1 suuremmalle säteilylle normaalin käytön, ylläpidon tai huollon aikana.

Huomautus laserlaitteesta

Tämä kirjoitin on Yhdysvalloissa luokan I (1) laserlaitteiden DHHS 21 CFR Subchapter J -määrityksen mukainen ja muualla luokan I laserlaitteiden IEC 60825-1 -määrityksen mukainen.

Luokan I laserlaitteiden ei katsota olevan vaarallisia käyttäjälle. Kirjoittimessa on sisäinen luokan IIIb (3b) 5 milliwatin galliumarsenidilaser, joka toimii aaltoalueella 770 - 795 nanometriä. Laserjärjestelmä ja kirjoitin on suunniteltu siten, että käyttäjä ei altistu luokan I määräytyksiä voimakkaammalle säteilylle kirjoittimen normaalin toiminnan, käyttäjän tekemien huoltotoimien tai muiden huoltotoimien yhteydessä.

VARO! Avattaessa ja suojalukitus ohitettaessa olet alttiina näkymättömälle lasersäteilylle. Älä katso säteeseen.

WARNING! Osynlig laserstrålning när denna del är öppnad och spärren är urkopplad. Betrakta ej strålen.

Laser-notis

Denna skrivare är i USA certifierad att motsvara kraven i DHHS 21 CFR, underparagraf J för laserprodukter av Klass I (1). I andra länder uppfyller skrivaren kraven för laserprodukter av Klass I enligt kraven i IEC 60825-1.

Laserprodukter i Klass I anses ej hälsovådliga. Skrivaren har en inbyggd laser av Klass IIIb (3b) som består av en laserenhet av gallium-arsenid på 5 milliwatt som arbetar i våglängdsområdet 770-795 nanometer. Lasersystemet och skrivaren är utformade så att det aldrig finns risk för att någon person utsätts för laserstrålning över Klass I-nivå vid normal användning, underhåll som utförs av användaren eller annan föreskriven serviceåtgärd.

Laser-melding

Skriveren er godkjent i USA etter kravene i DHHS 21 CFR, underkapittel J, for klasse I (1) laserprodukter, og er i andre land godkjent som et Klasse I-laserprodukt i samsvar med kravene i IEC 60825-1.

Klasse I-laserprodukter er ikke å betrakte som farlige. Skriveren inneholder internt en klasse IIIb (3b)-laser, som består av en gallium-arsenlaserenhet som avgir stråling i bølgelengdeområdet 770-795 nanometer. Lasersystemet og skriveren er utformet slik at personer aldri utsettes for laserstråling ut over klasse I-nivå under vanlig bruk, vedlikehold som utføres av brukeren, eller foreskrevne serviceoperasjoner.

Avís sobre el Làser

Segons ha estat certificat als Estats Units, aquesta impressora compleix els requisits de DHHS 21 CFR, apartat J, pels productes làser de classe I (1), i segons ha estat certificat en altres llocs, és un producte làser de classe I que compleix els requisits d'IEC 60825-1.

Els productes làser de classe I no es consideren perillosos. Aquesta impressora conté un làser de classe IIIb (3b) d'arseniür de gal.li, nominalment de 5 mil.liwats, i funciona a la regió de longitud d'ona de 770-795 nanòmetres. El sistema làser i la impressora han sigut concebuts de manera que mai hi hagi exposició a la radiació làser per sobre d'un nivell de classe I durant una operació normal, durant les tasques de manteniment d'usuari ni durant els serveis que satisfacin les condicions prescrites.

レーザーに関するお知らせ

このプリンターは、米国ではDHHS 21 CFRサブチャプターJのクラスI (1)の基準を満たしたレーザー製品であることが証明されています。また米国以外ではIEC 825の基準を満たしたクラスIのレーザー製品であることが証明されています。

クラスIのレーザー製品には危険性はないと考えられています。このプリンターはクラスIII b (3 b)のレーザーを内蔵しています。このレーザーは、波長が770 ~ 795ナノメートルの範囲で、通常5ミリワットのガリウム砒化物を放射するレーザーです。このレーザーシステムとプリンターは、通常の操作、ユーザのメンテナンス、規定された修理においては、人体がクラスIのレベル以上のレーザー放射に晒されることのないよう設計されています。

注意：

本打印机被美国认证合乎 DHHS 21 CFR Subchapter I 对分类 I (1) 激光产品的标准，而在其他地区则被认证合乎 IEC 825 的标准。

分类 I 激光产品一般认为不具危险性，本打印机内部含有分类 IIIb (3b) 的激光，在操作过程中会产生 5 毫瓦含镓及砷的微量激光，其波长范围在 770-795 nm 之间。本激光系统及打印机的设计，在一般操作、使用者维护或规定内的维修情况下，不会使人体接触分类 I 以上等级的辐射。

본프린터는 1등급 레이저 제품들에 대한 DHHS 21 CFR Subchapter 3의 규정을 준수하고 있음을 미국에서 인증받았으며, 그외의 나라에서도 IEC 825 규정을 준수하는 1등급 레이저 제품으로서 인증을 받았습니다.

1등급 레이저 제품들은 안전한 것으로 간주됩니다. 본 프린터는 5 밀리와트 갈륨 아르세나이드 레이저로서 770-795 나노미터의 파장대에서 활동하는 Class III (3b) 레이저를 내부에 갖고 있습니다. 본 레이저 시스템과 프린터는 정상 작동 중이나 유지 보수 중 또는 규정된 서비스 상태에서 상기의 Class I 수준의 레이저 방출에 사람이 절대 접근할 수 없도록 설계되어 있습니다.

Lithium warning

	<p>CAUTION</p> <p>This product contains a lithium battery. THERE IS A RISK OF EXPLOSION IF THE BATTERY IS REPLACED BY AN INCORRECT TYPE. Discard used batteries according to the battery manufacturer's instructions and local regulations.</p>
---	--

Safety information

- The safety of this product is based on testing and approvals of the original design and specific components. The manufacturer is not responsible for safety in the event of use of unauthorized replacement parts.
- The maintenance information for this product has been prepared for use by a professional service person and is not intended to be used by others.
- There may be an increased risk of electric shock and personal injury during disassembly and servicing of this product. Professional service personnel should understand this and take necessary precautions.
-  **CAUTION:** When you see this symbol, there is a danger from hazardous voltage in the area of the product where you are working. Unplug the product before you begin, or use caution if the product must receive power in order to perform the task.

Consignes de sécurité

- La sécurité de ce produit repose sur des tests et des agréments portant sur sa conception d'origine et sur des composants particuliers. Le fabricant n'assume aucune responsabilité concernant la sécurité en cas d'utilisation de pièces de rechange non agréées.
- Les consignes d'entretien et de réparation de ce produit s'adressent uniquement à un personnel de maintenance qualifié.
- Le démontage et l'entretien de ce produit pouvant présenter certains risques électriques, le personnel d'entretien qualifié devra prendre toutes les précautions nécessaires.
-  **ATTENTION :** Ce symbole indique la présence d'une tension dangereuse dans la partie du produit sur laquelle vous travaillez. Débranchez le produit avant de commencer ou faites preuve de vigilance si l'exécution de la tâche exige que le produit reste sous tension.

Norme di sicurezza

- La sicurezza del prodotto si basa sui test e sull'approvazione del progetto originale e dei componenti specifici. Il produttore non è responsabile per la sicurezza in caso di sostituzione non autorizzata delle parti.
- Le informazioni riguardanti la manutenzione di questo prodotto sono indirizzate soltanto al personale di assistenza autorizzato.
- Durante lo smontaggio e la manutenzione di questo prodotto, il rischio di subire scosse elettriche e danni alla persona è più elevato. Il personale di assistenza autorizzato deve, quindi, adottare le precauzioni necessarie.
-  **ATTENZIONE:** Questo simbolo indica la presenza di tensione pericolosa nell'area del prodotto. Scollegare il prodotto prima di iniziare o usare cautela se il prodotto deve essere alimentato per eseguire l'intervento.

Sicherheitshinweise

- Die Sicherheit dieses Produkts basiert auf Tests und Zulassungen des ursprünglichen Modells und bestimmter Bauteile. Bei Verwendung nicht genehmigter Ersatzteile wird vom Hersteller keine Verantwortung oder Haftung für die Sicherheit übernommen.
- Die Wartungsinformationen für dieses Produkt sind ausschließlich für die Verwendung durch einen Wartungsfachmann bestimmt.
- Während des Auseinandernehmens und der Wartung des Geräts besteht ein zusätzliches Risiko eines elektrischen Schlags und körperlicher Verletzung. Das zuständige Fachpersonal sollte entsprechende Vorsichtsmaßnahmen treffen.
-  **ACHTUNG:** Dieses Symbol weist auf eine gefährliche elektrische Spannung hin, die in diesem Bereich des Produkts auftreten kann. Ziehen Sie vor den Arbeiten am Gerät den Netzstecker des Geräts, bzw. arbeiten Sie mit großer Vorsicht, wenn das Produkt für die Ausführung der Arbeiten an den Strom angeschlossen sein muß.

Pautas de Seguridad

- La seguridad de este producto se basa en pruebas y aprobaciones del diseño original y componentes específicos. El fabricante no es responsable de la seguridad en caso de uso de piezas de repuesto no autorizadas.
- La información sobre el mantenimiento de este producto está dirigida exclusivamente al personal cualificado de mantenimiento.
- Existe mayor riesgo de descarga eléctrica y de daños personales durante el desmontaje y la reparación de la máquina. El personal cualificado debe ser consciente de este peligro y tomar las precauciones necesarias.
-  **PRECAUCIÓN:** este símbolo indica que el voltaje de la parte del equipo con la que está trabajando es peligroso. Antes de empezar, desenchufe el equipo o tenga cuidado si, para trabajar con él, debe conectarlo.

Informações de Segurança

- A segurança deste produto baseia-se em testes e aprovações do modelo original e de componentes específicos. O fabricante não é responsável pela segurança, no caso de uso de peças de substituição não autorizadas.
- As informações de segurança relativas a este produto destinam-se a profissionais destes serviços e não devem ser utilizadas por outras pessoas.
- Risco de choques eléctricos e ferimentos graves durante a desmontagem e manutenção deste produto. Os profissionais destes serviços devem estar avisados deste facto e tomar os cuidados necessários.
-  **CUIDADO:** Quando vir este símbolo, existe a possível presença de uma potencial tensão perigosa na zona do produto em que está a trabalhar. Antes de começar, desligue o produto da tomada eléctrica ou seja cuidadoso caso o produto tenha de estar ligado à corrente eléctrica para realizar a tarefa necessária.

Informació de Seguretat

- La seguretat d'aquest producte es basa en l'avaluació i aprovació del disseny original i els components específics.
El fabricant no es fa responsable de les qüestions de seguretat si s'utilitzen peces de recanvi no autoritzades.
- La informació pel manteniment d'aquest producte està orientada exclusivament a professionals i no està destinada a ningú que no ho sigui.
- El risc de xoc elèctric i de danys personals pot augmentar durant el procés de desmuntatge i de servei d'aquest producte. El personal professional ha d'estar-ne assabentat i prendre les mesures convenients.
-  **PRECAUCIÓ:** aquest símbol indica que el voltatge de la part de l'equip amb la qual esteu treballant és perillós. Abans de començar, desendolieu l'equip o extremeu les precaucions si, per treballar amb l'equip, l'heu de connectar.

안전 사항

- 본 제품은 원래 설계 및 특정 구성품에 대한 테스트 결과로 안정성이 입증된 것입니다. 따라서 무허가 교체부품을 사용하는 경우에는 제조업체에서 안전에 대한 책임을 지지 않습니다.
- 본 제품에 관한 유지 보수 설명서는 전문 서비스 기술자용으로 작성된 것이므로, 비전문가는 사용할 수 없습니다.
- 본 제품을 해체하거나 정비할 경우, 전기적인 충격을 받거나 상처를 입을 위험이 커집니다. 전문 서비스 기술자는 이 사실을 숙지하고, 필요한 예방 조치를 취하도록 하십시오.
-  **주의:** 이 표시는 해당영역에서 고압전류가 흐른다는 위험 표시입니다. 시작전에 플러그를 뽑으시거나, 주의를 기울여 주시기 바랍니다.

安全信息

- 本产品的安全性以原来设计和特定产品的测试结果和认证为基础。万一使用未经许可的替换部件，制造商不对安全性负责。
- 本产品的维护信息仅供专业服务人员使用，并不打算让其他人使用。
- 本产品在拆卸、维修时，遭受电击或人员受伤的危险性会增高，专业服务人员对这点必须有所了解，并采取必要的预防措施。
-  **切记:** 当您看到此符号时，说明在您工作的产品区域有危险电压的存在。请在开始操作前拔掉产品的电源线，或者在产品必须使用电源来执行任务时，小心从事。

Preface

This manual contains maintenance procedures for service personnel. It is divided into the following chapters:

1. **General information** contains a general description of the MFP and the maintenance approach used to repair it. Special tools and test equipment, as well as general environmental and safety instructions, are discussed.
 2. **Diagnostic information** contains an error indicator table, symptom tables, and service checks used to isolate failing field replaceable units (FRUs).
 3. **Diagnostic aids** contains tests and checks used to locate or repeat symptoms of MFP problems.
 4. **Repair information** provides instructions for making MFP adjustments and removing and installing FRUs.
 5. **Connector locations** uses illustrations to identify the connector locations and test points on the MFP.
 6. **Preventive maintenance** contains the lubrication specifications and recommendations to prevent problems.
 7. **Parts catalog** contains illustrations and part numbers for individual FRUs.
- Appendix A** contains service tips and information.
Appendix B contains representative print samples.

Conventions

Note: A note provides additional information.

Warning: A warning identifies something that might damage the product hardware or software.

There are several types of caution statements:

	<p>CAUTION</p> <p>A caution identifies something that might cause a servicer harm.</p>
---	---

	<p>CAUTION</p> <p>This type of caution indicates there is a danger from hazardous voltage in the area of the product where you are working. Unplug the product before you begin, or use caution if the product must receive power in order to perform the task.</p>
---	--

	<p>CAUTION</p> <p>This type of caution indicates a hot surface.</p>
---	--

1. General information

Models

Model name	Machine type/ model	Description
Lexmark X734de	7526-235	4-in-1 Color MFP
Lexmark X734de	7526-275	4-in-1 Color MFP, with fax modem
Lexmark X734de	7526-295	4-in-1 Color MFP, with fax modem
Lexmark X736de	7526-436	4-in-1 Color MFP
Lexmark X736de	7526-476	4-in-1 Color MFP with fax modem
Lexmark X736de	7526-496	4-in-1 Color MFP, with fax modem
Lexmark X738de	7526-636	4-in-1 Color MFP
Lexmark X738de, dte	7526-676	4-in-1 Color MFP with fax modem

Options and features

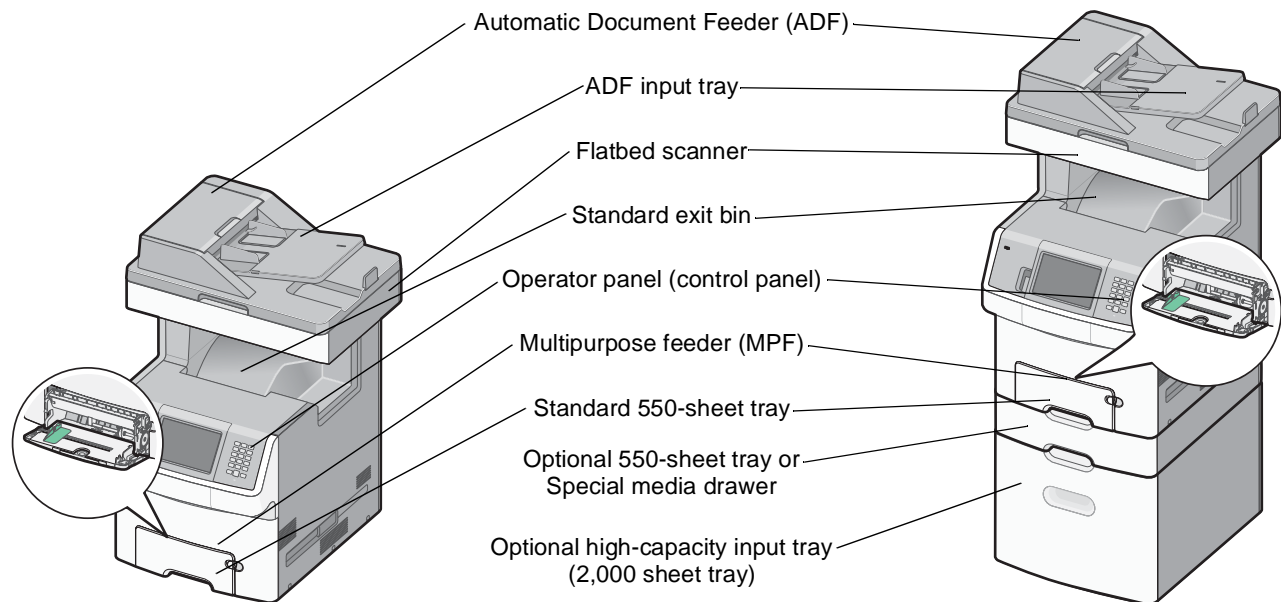

Media options

The Lexmark X73xde MFP support 550-sheet drawers, special media drawers, and the 2000-sheet high-capacity input tray. The Lexmark X73xde MFP support up to four input options.

The options can include any combination of 550 sheet drawers and 550 sheet Specialty Media Drawers, with a maximum of one 2000 sheet drawer (always at the lowest position.) A caster base is required with some configurations. Including the base machine capacity of 650 sheets, the MFP supports up to 3,200 sheets. The Lexmark C73xde options are compatible with the Lexmark X73xde MFP, but not with any other Lexmark printers. No other options are supported by the X73xde.

The media options include:

- **550-Sheet Drawer**—This optional input source installs beneath the printer, and it holds approximately 550 sheets of (20 lb.) paper.
- **High Capacity Input Tray**—This optional input source installs beneath the printer, and it holds approximately 2000 sheets of (20 lb.) paper.
- **Specialty Media Drawer**—This optional input source installs beneath the printer, and it holds approximately 550 sheets of (20 lb.) paper, or 85 standard envelopes.

Memory options

- **Additional memory card**—The memory options for the X73xde printers are 200 pin DDR2, SODIMM, and they are available at 256MB, 512MB, and 1GB sizes.
- **Flash memory card**—Flash Memory cards are available in 256MB.
- **Hard disk**—If larger storage is required, an optional hard disk is available.

Printer and scanner specifications

Dimensions

The following table contains the dimensions and weight for each of the respective printer models. This does not include packaging.

	Height	Width	Depth	Weight
Lexmark X734de, X736de, X738de				
Basic printer (cartridges only)	787 mm (31 in)	546 mm (21.5 in)	622 mm (24.5 in)	44kg (96.8 lbs)
Lexmark X738dte				
Printer with 550-sheet optional drawer	909 mm (35.8 in)	546 mm (21.5 in)	622 mm (24.5 in)	48.3 kg (107 lbs)
Paper input options				
550-sheet drawer	122 mm* (4.8 in)	435 mm (17.1 in)	545 mm (21.5 in)	4.4 kg (9.7 lbs)
550-sheet Specialty Media Drawer	122 mm* (4.8 in)	435 mm (17.1 in)	545 mm (21.5 in)	4.4 kg (9.7 lbs)
High-capacity input tray (2000-sheet) only	387 mm (15.2 in)	435 mm (17.1 in)	545 mm (21.5 in)	26.1 kg (57.5 lbs)
Furniture options				
Spacer	169 mm (6.7 in)	435 mm (17.1 in)	545 mm (21.5 in)	3.5 kg (7.6 lbs)
Caster base only	107 mm (4.2 in)	768 mm (30.2 in)	801 mm (31.5 in)	27.2 kg (60 lbs)
* Options are 6.6 in. high if you take into account the anti-tip post, which extend into another option or the multipurpose feeder.				

Clearances

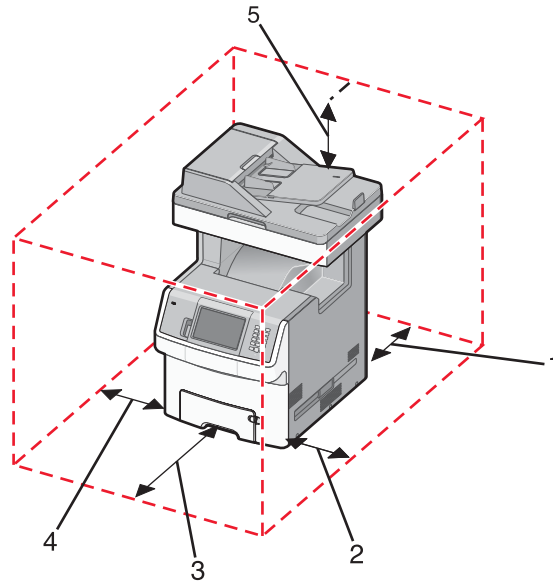

Number	Description	Clearance
1	Rear	100 mm (3.9 in)
2	Right side	100 mm (3.9 in)
3	Front	483 mm (19 in)
4	Left side	100 mm (3.9.)
5	Above	394 mm (15.5 in)

Multiple function printer specifications

Flatbed scanner	
Scanner type	Color/monochrome flatbed scanner with ADF (automatic document feeder)
Scan technology	Charge coupled device (CCD)
Light source	Xenon lamp
Number of light sources	One CCD module with one lamp
Maximum optical resolution - flatbed	600 x 600 dpi (Monochrome and color)
Scan Area - flatbed	Maximum 8.5" x 14" (216 mm x 356 mm)
ADF scanner	
ADF type	X734de —Simplex ADF with C-shaped path X736de, X738de, X738dte —Duplex scan, recirculating (RADF), C-shaped path
Optical resolution ADF (monochrome and color)	Maximum 600 x 600 dpi
ADF input and output capacity	50 sheets (20 lb or 75 g/m ² bond)
Scanner media depth (thickness)	Maximum: 0.15 mm Minimum: 0.05 mm

ADF scanner (continued)	
Scanner media weight	Maximum: 32 lb. (120 g/m ²) Minimum: 14 lb. (52g/m ²)
Scan area - ADF	Maximum: 8.5 in. x 14 in. (216 mm x 355 mm) SEF Minimum: 4.1 in. x 5.8 in. (105 mm x 148 mm) SEF
Printer	
Print technology	Belt fuser
Paper feed orientation	Short Edge Fed (SEF)
Fax	
Modem	Built-in Group 3-compatible, full function fax, 33,600bps, Max V.34 Half Duplex

Memory

Memory	All models
Standard memory —The standard RAM is soldered onto the system board.	
Memory size	512MB
Optional memory —Optional DIMM (Dual Inline Memory Module) is a card that can be plugged into an available memory slot on the system board. Flash memory is a card that can also be plugged into an available slot. One firmware card (DLE) and one flash memory card are supported.	
Maximum number of memory (DIMM) slots	1
Maximum number of flash memory slots	1
DIMM memory sizes available	256MB, 512MB, 1024MB
Flash (Nand Flash)	256
Maximum possible memory	1536MB

Resolution

The following resolutions are available:

- 4800CQ (default resolution)
- 1200 x 1200 dpi (at reduced printer speed)

Data streams

- PostScript 3 emulation
- PCL 5c and PCL 6 Emulation
- PDF 1.6 with backward compatibility
- PPDS (activated from configuration menu)
- HTML
- XPS
- Direct Image (TIFF, TIF, JPEG, JPG, GIF, PNG, BMP, PCX, and DCX)

Environment specifications

Environment	Specifications
Operating	
Air temperature—Operating	15.6° to 32.2° C (60° to 90° F)
Air temperature—Power off	10° to 40° C (50° to 104° F)
Air Relative Humidity	8% to 80%
Wet Bulb Temperature—Operating	22.8° C (73.0° F) Maximum
Web Bulb Temperature—Power off	26.7° C (80.1° F) Maximum
Altitude	0–3,048 meters (10,000 ft.)
Ambient Operating Environment*	15.6° to 32.2° C (60° to 90° F) and 8% to 80% RH
Shipping and storage	
Cartridges (packaged)	-40° C to 40° C (104° Fahrenheit)
Printer with Cartridges (packaged)	-40° C to 40° C (104° Fahrenheit)
Printer without Cartridges	-40° C to 40° C (104° Fahrenheit)
Air Relative Humidity	Relative Humidity 8% to 80%
Altitude	0–10,300 meters (34,000 feet)
Web Bulb Temperature—Power Off	26.7° C (80.1° F) Maximum
* In some cases performance specifications, such as paper OCF and EP cartridge usage, are specified to be measured at an ambient condition.	

Electrical and power specifications

The following table specifies nominal average power requirements for the basic printer configurations. All power levels are shown in Watts (W). Maximum current is given in Amperes (A).

Printing states	Lexmark X734de	Lexmark X736de	Lexmark X738de, X738dte
Printing states			
Off	0 W	0 W	0 W
Power Saver	24 W	27 W	27 W
Ready mode	60 W	70 W	70 W
Continuous copying	530 W	600 W	600 W
Continuous printing	490 W	560 W	560 W
Typical Electricity Consumption (TEC)			
Default settings	6.18 kwh/week	7.22 kwh/wk	7.22 kwh/week
Eco Mode settings	5.19 kwh/week	5.93 kwh/wk	5.93 kwh/week
Maximum current while printing			
100 Volts	9 A	9 A	9 A
120 Volts	8 A	8 A	8 A
230 Volts	4 A	4 A	4 A

Low-voltage models

- 110 to 127 V ac at 50 to 60 Hertz (Hz) nominal
- 90 to 135 V ac, extreme

High-voltage models

- 220 to 240 V ac at 50 to 60 Hz (not available in all countries)
- 198 to 254 V ac, extreme

Notes:

- Using a 220 V ac to 110 V ac power converter with the low-voltage printer is not recommended.
- Using an inverter (12 V dc to 120 V ac for example) to power the printer is not recommended.
- Only duplex models are ENERGY STAR certified.

Acoustic specifications

All acoustic measurements are made in accordance with ISO 7779:1999—*Accoustics: Measurement of airborne noise emitted by information technology and telecommunications* and reported in conformance with ISO 9296:

1988-04-15—Accoustics Declared noise emission values of computer and business equipment.

Operating mode	Quiet Mode Off		Quiet Mode On	
	Sound pressure level (dBA)	Sound power level (Bels)	Sound pressure level (dBA)	Sound power level (Bels)
Simplex printing	53	6.9	48	6.3
Duplex printing	54	6.9	N/A	N/A
Copying	54	7.0	N/A	N/A
Scanning	54	7.2	N/A	N/A
Standby mode	35	4.7	N/A	N/A

Lexmark has implemented features in the X73xde Series MFPs that allow our customers to easily select various operating modes in order to reach their sustainability goals related to environmental and noise pollution. These new features are Eco Mode and Quiet Mode.

Eco Mode optimizes printer settings to minimize the environmental impact while Quiet Mode significantly reduces acoustics. For more information, refer to the *Users Guide*.

Quiet Mode	
Off	The parameters that are changed are returned to their factory default state. This mode will support performance claims for the product.
On	MFP will be configured to run in a reduced noise mode. Primarily, the user is trading performance for quieter operation. The following parameters are affected: <ul style="list-style-type: none"> • Process speed is reduced • Key press sounds and alarms, for example, are disabled or minimized • Engine motors are not ramped up prior to the job being ready to actually print • Fans run in reduced speed or are turned off

Media specifications

Paper designed for use with xerographic copiers should provide satisfactory print quality and feed reliability. Other types of media may be suitable. It is recommended that users test any particular brand for suitability to their applications. Refer to the printer *User's Guide* for additional media specifications.

Paper

Follow the media guidelines below for successful printing:

- Rough, highly textured, limp, or pre-curved papers will result in lower print quality and more frequent paper feed failures.
- Colored papers must be able to withstand 190° C (374° F) fusing temperature.
- Preprinted forms and letterheads must be able to withstand 190° C (374° F) fusing temperature and should be selected using guidelines found in the printer *User's Guide*. The chemical process used in preprinting may render some papers unsuitable for use.
- Unsuitable papers include:
 - Multi-part forms and documents
 - Chemically treated papers; coated
 - Synthetic and thermal papers
 - A5 paper less than 80 g/m² (21 lb)
 - Recycled paper less than 75 g/m² (20 lb)
 - Preprinted papers requiring a high degree of registration.
 - Recycled paper less than 80 g/m² (21 lb) may cause unacceptable results.

Envelopes

- All envelopes should be new, unused, and without package damage.
- Envelopes with excessive curl or twist exceeding 6 mm, those stuck together, those with bent corners or nicked edges, or those that interlock should not be used.
- Minimum weight: 60 g/m² (16 lb.)
- The following envelopes should not be used:
 - Envelopes with windows, holes, perforations, cutouts, or deep embossing
 - Envelopes with metal clasps, string ties, or metal folding bars
 - Envelopes with exposed flap adhesive when the flap is in the closed position.
- For best results, printing on new 90 g/m² (24 lb.) sulfite or 25% cotton bond envelopes is recommended.
- Under high humidity conditions (over 60%), envelopes may seal during printing.

Transparencies

- Use letter or A4-size transparencies for color laser printers only.
- Do not use inkjet transparencies.

Labels

Labels should be selected using guidelines found in the *User's Guide* or the *Card Stock and Label Guide*, and tested for acceptability.

Using recycled paper and other office papers

Recycled office paper produced specifically for use in laser (electrophotographic) printers may be used in your printer. However, no blanket statement can be made that all recycled paper will feed well.

Generally, the following property guidelines apply to recycled paper.

- Low moisture content (4–5%)
- Suitable smoothness (100–200 Sheffield units, or 140–350 Bendtsen units, European)
Note: Some much smoother papers (such as premium 24 lb laser papers, 50–90 Sheffield units) and much rougher papers (such as premium cotton papers, 200–300 Sheffield units) have been engineered to work very well in laser printers, despite surface texture. Before using these types of paper, consult your paper supplier.
- Suitable sheet-to-sheet coefficient of friction (0.4–0.6)
- Sufficient bending resistance in the direction of feed

Recycled paper, paper of lower weight (<60 g/m² [16 lb bond]) and/or lower caliper (<3.8 mils [0.1 mm]), and paper that is cut grain-short for portrait (or short-edge) fed printers may have lower bending resistance than is required for reliable paper feeding. Before using these types of paper for laser (electrophotographic) printing, consult your paper supplier. Remember that these are general guidelines only and that paper meeting these guidelines may still cause paper feeding problems in any laser printer (for example, if the paper curls excessively under normal printing conditions).

Input and output capacities

The following table describes the media options that each model supports, and the estimated capacities in stand and maximum configurations. Capacity may vary and is subject to media specifications and printer operating environment. The capacities are based on plain paper at 75g/m².

Function	Support by model	
	Lexmark X734de, X736de, X738de	Lexmark X738dte
Standard input sources		
Primary tray capacity (sheets)	550	1,100
Multipurpose feeder capacity (sheets)	100	100
Number of standard sources (primary tray and multipurpose feeder)	2	3
Total standard capacity (sheets)	650	1200
Optional input sources		
550-Sheet Drawer (sheets)	550	550
High-capacity input tray (HCIT) (sheets)	2,000	2,000
Specialty Media Drawer (sheets)*	550 (or 85 envelopes)	550 (or 85 envelopes)
Maximum number of high-capacity input tray (must be installed on the bottom)	1	1
Maximum number of standard and optional input sources*	5	5
Maximum capacity for standard and options input sources (sheets)*	3,200*	3,200*
Standard output bin capacity (sheets)		
Maximum output bin capacity (sheets)	250	250
Duplex capability	Standard	
* Optional input drawers include the 550-Sheet Drawer, 550-sheet Specialty Media Drawer, and High-capacity input tray (HCIT). The maximum number of input options is dependent upon whether the MFP is used on a desktop/tabletop or floor-standing with a caster base, and if the configuration meets UL Safety specifications. Please refer to www.lexmark.com/multifunctionprinters for more information.		

Input and output sizes and types

Media Sizes	Primary 550-sheet tray	Multipurpose feeder	Optional 550-sheet tray	Optional Speciality Media	Optional 2000-sheet feeder (HCIT)	Duplex
Paper sizes						
A4 210 x 297 mm	✓	✓	✓	✓	✓	✓
A5 148 x 210 mm	✓	✓	✓	✓		✓
A6 105 x 148 mm		✓		✓		
ISO B5 176 x 250 mm ^a	✓	✓	✓	✓		✓
JIS B5 182 x 257 mm	✓	✓	✓	✓		✓
Officio (Mexico) 216 x 340 mm	✓	✓	✓	✓		✓
Letter 8.5 x 11 in.	✓	✓	✓	✓	✓	✓
Legal 8.5 x 14 in.	✓	✓	✓	✓	✓	✓
3 x 5 ¹		✓		✓		
4 x 5 ¹		✓		✓		
Statement 5.5 x 8.5 in.		✓		✓		✓
Executive 7.25 x 10.5 in.	✓	✓	✓	✓		✓
Folio 8.5 x 13 in.	✓	✓	✓	✓		✓
Universal ^b (width x length)						
• 76.2 x 123.8 mm (3 x 4.9 in) to 215.9 (8.5 x 14 in)		✓		✓		
• 148 x 210 mm (5.8 x 8.3 in) to 215.8 x 355.6 mm (8.5 x 48 in)	✓	✓	✓	✓		✓
• 76.2 x 123.8 mm (3 x 4.9 in) to 215.9 x 1219 mm (8.5 x 48 in) ^c		✓				
<p>^a These sizes are accessible using Universal Size setting.</p> <p>^b Lower feed reliability may be encountered when feeding non-standard size media.</p> <p>^c The maximum length supported by this printer is 914.4 mm (36 in).</p> <p>^d These sizes are accessible using Other Envelope setting.</p>						

Media Sizes (continued)	Primary 550-sheet tray	Multipurpose feeder	Optional 550-sheet tray	Optional Speciality Media	Optional 2000-sheet feeder (HCIT)	Duplex
Envelopes						
C6 Envelope 114 x 162 mm ^d		✓		✓		
B6 Envelope 125 x 176 mm ^d		✓		✓		
C65 Envelope 114 x 229 mm ^d		✓		✓		
C5 Envelope 162 x 229 mm		✓		✓		
B5 Envelope 176 x 250 mm		✓		✓		
DL Envelope 110 x 220 mm		✓		✓		
6 3/4 Envelope 3.4 x 6.5 in ^d		✓		✓		
7 3/4 Envelope 3.4 x 7.5 in		✓		✓		
9 Envelope 3.9 x 8.9 in		✓		✓		
10 Envelope 4.13 x 9.5 in		✓		✓		
11 Envelope 4.5 x 10.4 in ^d		✓		✓		
12 Envelope 4.8 x 11 in ^d		✓		✓		
<p>^a These sizes are accessible using Universal Size setting.</p> <p>^b Lower feed reliability may be encountered when feeding non-standard size media.</p> <p>^c The maximum length supported by this printer is 914.4 mm (36 in).</p> <p>^d These sizes are accessible using Other Envelope setting.</p>						

Media weight, primary tray and option tray				
Size	Type		Weight	
Letter, Legal, A4	Xerographic and bond	Long grain	60 g/m ² –162.7 g/m ² (16 lb–43 lb)	
		Short grain	162.7 g/m ² –198.9 g/m ² (43 lb–53.2 lb)	
	Recycled	Long grain	75 g/m ² –177 g/m ² (20 lb–47 lb)	
		Short grain	105 g/m ² –218 g/m ² (28 lb–58 lb)	
	Cardstock (maximum)	Index long/short	162.7 g/m ² –198.9 g/m ² (90 lb–110 lb)	
		Cover long/short	162.7 g/m ² –198.9 g/m ² (60.1 lb–73.6 lb)	
		Tag long/short	162.7 g/m ² –198.9 g/m ² (100 lb–122.2 lb)	
	Transparencies			161 g/m ² – 179 g/m ² Thickness: 0.12–0.14 mm (4.8–5.4 mil)
	Labels	Paper	180 g/m ² –300 g/m ² (48 lb–80 lb)	
Vinyl		180 g/m ² –300 g/m ² (48 lb–80 lb)		
A5, JIS B5, Executive	Xerographic and bond	Long grain	75 g/m ² –177 g/m ² (20 lb to 47 lb)	
		Short grain	90 g/m ² –218 g/m ² (24 lb–58 lb)	
Universal	Xerographic and bond	Long grain	75 g/m ² –177 g/m ² (20 lb–47 lb)	
		Short grain	90 g/m ² –218 g/m ² (24 lb–58 lb)	

Paper guidelines

Paper characteristics

The following paper characteristics affect print quality and reliability. Consider these characteristics when evaluating new paper stock.

Weight—The printer can automatically feed paper weights from 60 to 16217 g/m² (16 to 43 lb bond) grain long. Paper lighter than 60 g/m² (16 lb) might not be stiff enough to feed properly, causing jams. For best performance, use 75 g/m² (20 lb bond) grain long paper. For paper smaller than 182 x 257 mm (7.2 x 10.1 in), we recommend 90 g/m² (24 lb) or heavier paper.

Note: Duplex is supported only for 63 g/m²–170 g/m² (17 lb–45 lb bond) paper.

Curl—Curl is the tendency for paper to curl at its edges. Excessive curl can cause paper feeding problems. Curl can occur after the paper passes through the printer, where it is exposed to high temperatures. Storing paper unwrapped in hot, humid, cold, or dry conditions, even in the trays, can contribute to paper curling prior to printing and can cause feeding problems.

Smoothness—Paper smoothness directly affects print quality. If paper is too rough, toner cannot fuse to it properly. If paper is too smooth, it can cause paper feeding or print quality issues. Always use paper between 100 and 300 Sheffield points; however, smoothness between 150 and 200 Sheffield points produces the best print quality.

Moisture content—The amount of moisture in paper affects both print quality and the ability of the printer to feed the paper correctly. Leave paper in its original wrapper until it is time to use it. This limits the exposure of paper to moisture changes that can degrade its performance.

Condition paper before printing by storing it in its original wrapper in the same environment as the printer for 24 to 48 hours before printing. Extend the time several days if the storage or transportation environment is very different from the printer environment. Thick paper may also require a longer conditioning period.

Grain direction—Grain refers to the alignment of the paper fibers in a sheet of paper. Grain is either grain long, running the length of the paper, or grain short, running the width of the paper. For 60 to 135 g/m² (16 to 36 lb bond) paper, grain long paper is recommended. For papers heavier than 135 g/m², grain short is recommended.

Fiber content—Most high-quality xerographic paper is made from 100% chemically treated pulped wood. This content provides the paper with a high degree of stability resulting in fewer paper feeding problems and better print quality. Paper containing fibers such as cotton can negatively affect paper handling.

Unacceptable paper

The following paper types are not recommended for use with the printer:

- Chemically treated papers used to make copies without carbon paper, also known as carbonless papers, carbonless copy paper (CCP), or no carbon required (NCR) paper
- Preprinted papers with chemicals that may contaminate the printer
- Preprinted papers that can be affected by the temperature in the printer fuser
- Preprinted papers that require a registration (the precise print location on the page) greater than ±2.3 mm (±0.9 in), such as optical character recognition (OCR) forms

Note: In some cases, registration can be adjusted with a software application to successfully print on these forms.
- Coated papers (erasable bond), synthetic papers, thermal papers
- Rough-edged, rough or heavily textured surface papers, or curled papers
- Recycled papers that fail EN12281:2002 (European)
- Paper weighing less than 60 g/m² (16 lb)
- Multiple-part forms or documents

Selecting paper

Using appropriate paper prevents jams and helps ensure trouble-free printing.

To help avoid jams and poor print quality:

- *Always* use new, undamaged paper.
- Before loading paper, know the recommended print side of the paper. This information is usually indicated on the paper package.
- Do not use paper that has been cut or trimmed by hand.
- Do not mix paper sizes, types, or weights in the same source; mixing results in jams.
- Do not use coated papers unless they are specifically designed for electrophotographic printing.

Selecting preprinted forms and letterhead

Use these guidelines when selecting preprinted forms and letterhead:

- Use grain long for 60 to 90 g/m² (16 to 20 lb) weight paper.
- Use only forms and letterhead printed using an offset lithographic or engraved printing process.
- Avoid papers with rough or heavily textured surfaces.

Use papers printed with heat-resistant inks designed for use in xerographic copiers. The ink must be able to withstand temperatures up to 190°C (374°F) without melting or releasing hazardous emissions. Use inks that are not affected by the resin in toner. Inks that are oxidation-set or oil-based generally meet these requirements; latex inks might not. When in doubt, contact the paper supplier.

Preprinted papers such as letterhead must be able to withstand temperatures up to 190°C (374°F) without melting or releasing hazardous emissions.

Storing paper

Use these paper storage guidelines to help avoid jams and uneven print quality:

- For best results, store paper where the temperature is 21°C (70°F) and the relative humidity is 40%. Most label manufacturers recommend printing in a temperature range of 18 to 24°C (65 to 75°F) with relative humidity between 40 and 60%.
- Store paper in cartons when possible, on a pallet or shelf, rather than on the floor.
- Store individual packages on a flat surface.
- Do not store anything on top of individual paper packages.

Tools required for service

Flat-blade screwdrivers, various sizes
 #1 Phillips screwdriver, magnetic
 #2 Phillips screwdriver, magnetic
 #2 Phillips screwdriver, magnetic short-blade
 7/32 inch (5.5 mm) open-end wrench
 7.0 mm nut driver
 Needlenose pliers
 Diagonal side cutters
 Spring hook
 Feeler gauges
 Analog or digital multimeter
 Parallel wrap plug 1319128
 Twinax/serial debug cable 1381963
 Coax/serial debug cable 1381964
 Flash light (optional)

Any additional tools should be approved by Service before being listed here. Specialty tools might have to be purchased and provided to OEM/partners.

Acronyms

Delete any unused terms and add any terms that appear in your book.

ADF	Automatic Document Feeder
BLDC	Brushless DC Motor
BOR	Black Only Retract
BUR	Back Up Roll
C	Cyan
CCD	Charge-Coupled Device
COD	Color On Demand
CSU	Customer Setup
DIMM	Dual Inline Memory Module
DRAM	Dynamic Random Access Memory
EDO	Enhanced Data Out
EP	Electrophotographic Process
EPROM	Erasable Programmable Read-Only Memory
ESD	Electrostatic Discharge
FB	Flat Bed
FRU	Field Replaceable Unit

GB	Gigabyte
HCIT	High-Capacity Input Tray
HCOF	High-Capacity Output Finisher
HVPS	High-Voltage Power Supply
ISP	Internal Solutions Port
ITU	Image Transfer Unit
K	Black
LASER	Light Amplification by Stimulated Emission of Radiation
LCD	Liquid Crystal Display
LED	Light-Emitting Diode
LEF	Long-Edge Fed
LVPS	Low-Voltage Power Supply
M	Magenta
MPF	Multipurpose Feeder
MROM	Masked Read Only Memory
MS	Microswitch
NVRAM	Nonvolatile Random Access Memory
OEM	Original Equipment Manufacturer
OPT	Optical Sensor
PC	Photoconductor
pel	Picture element
POR	Power-On Reset
POST	Power-On Self Test
PSD	Position Sensing Device
PWM	Pulse Width Modulation
RIP	Raster Imaging Processor
ROM	Read Only Memory
SEF	Short-Edge Fed
SDRAM	Synchronous Dual Random Access Memory
SIMM	Single Inline Memory Module
SRAM	Static Random Access Memory
UPR	Used Parts Return
V ac	Volts alternating current
V dc	Volts direct current
VTB	Vacuum Transport Belt
Y	Yellow

2. Diagnostic information

Start

	<p>CAUTION</p> <p>Remove the power cord from the electrical outlet before you connect or disconnect any cable or electronic card or assembly for personal safety and to prevent damage to the printer.</p>
---	---

Use the service error code, user status message, user error message, symptom table, service checks, and diagnostic aids in this chapter to determine the corrective action necessary to repair a malfunctioning printer. They will lead you to solutions or service checks, including use of various tests.

Symptom tables

If your printer completes the **“Power-on self test (POST) sequence” on page 2-5** without an error, and you have a symptom, go to **“Symptom tables” on page 2-6**. Locate your symptom, and take the appropriate action.

Service errors (1xx.xx/9xx.xx)

If a service error code appears while you are working on the printer, go to **“Error codes and messages” on page 2-17**, and take the indicated action for that error.

Service error codes are indicated by a three-digit error code followed by a period and additional numbers in the format XXX.YY. In most cases, five digits are shown.

Paper jam messages (2xx.xx)

User attendance messages that indicate a paper jam these have been included with the service error codes since repeated instances may indicate an underlying service issue. Go to **“2xx paper jam messages” on page 2-19**.

User status and attendance messages

- User status messages provide the user with information on the current status of the printer.
- User attendance messages are indicated by a two-digit code that provides the user with information that explains a problem with a print cartridge, option, port, and so on. If a user error message displays, see **“User status and attendance messages” on page 2-7** or **“2xx paper jam messages” on page 2-19**.

Additional information

- **“Operator panel and menus” on page 2-2**
- **“Power-on self test (POST) sequence” on page 2-5**



Operator panel and menus



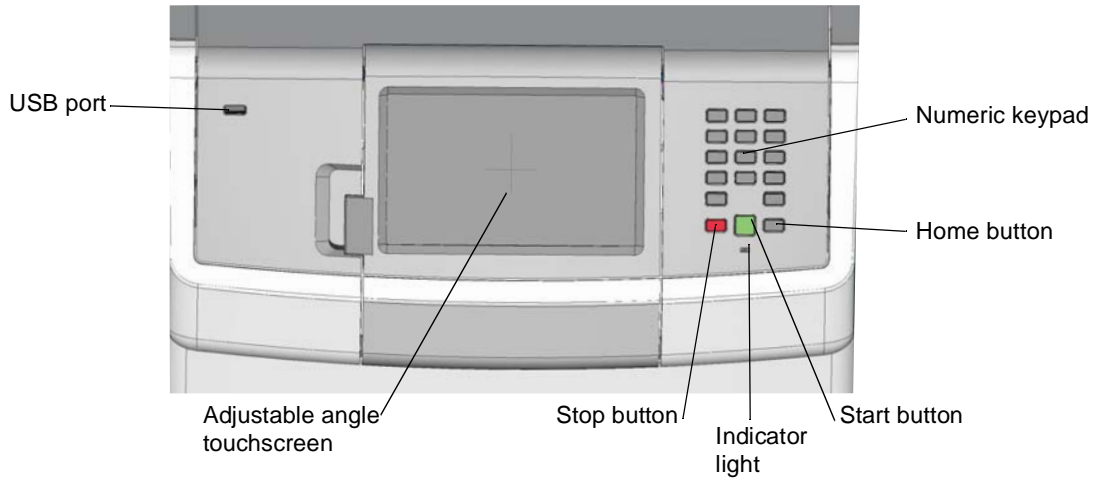





Operator panel



The operator panel consists of these items:



Buttons, icons, and light description

Button or light	Function										
Display	The display shows messages and pictures that communicate the status of the printer.										
Start 	<ul style="list-style-type: none"> Press Start to initiate the current job indicated on the display. From the home screen, press Start to start a copy job with the default settings. If pressed while a job is scanning, the button has no effect. 										
Stop 	<p>Stops all printer activity.</p> <p>A list of options is offered once Stopped appears on the display.</p>										
Home 	Press Home to return to the home screen.										
Indicator light	<p>The two-toned light emitting diode called the indicator light on the operator panel gives information about the status of the printer using the colors red and green.</p> <table border="1"> <thead> <tr> <th>Indicator light status</th> <th>Indicates</th> </tr> </thead> <tbody> <tr> <td>Off</td> <td>Printer power is off.</td> </tr> <tr> <td>Blinking green</td> <td>Printer is warming up, processing data, or printing a job.</td> </tr> <tr> <td>Solid green</td> <td>Printer is on, but idle.</td> </tr> <tr> <td>Solid red</td> <td>Operator intervention is required.</td> </tr> </tbody> </table>	Indicator light status	Indicates	Off	Printer power is off.	Blinking green	Printer is warming up, processing data, or printing a job.	Solid green	Printer is on, but idle.	Solid red	Operator intervention is required.
Indicator light status	Indicates										
Off	Printer power is off.										
Blinking green	Printer is warming up, processing data, or printing a job.										
Solid green	Printer is on, but idle.										
Solid red	Operator intervention is required.										

Button or light	Function
USB direct port	<p>Insert a USB flash drive to send data to the printer.</p> <p>Insert a USB cable from a digital camera to print photos with a PictBridge-enabled digital camera.</p>
<p>Numeric keypad</p> 	<p>Consists of the numbers 0–9, a backspace button, and a pound (#) button.</p>
	<p>Touch Select functions as a select button. Press this button to:</p> <ul style="list-style-type: none"> • Open a menu and display the first item in the menu (called a menu item). • Open a menu item and display the default setting.
	<p>Touch Submit to save the displayed menu item as the new user default setting. The printer issues a <i>Saved or Submitted Selection</i> message and returns to the menu item.</p> <p>Note: When a new setting is saved as the user default setting, it remains in effect until new settings are saved or until factory defaults are restored. Settings chosen from the software application can also change or override the user default settings selected from the operator panel.</p>
	<p>Touch these buttons to scroll up or down through menus, menu items, or settings, called menu item values, or to scroll between screens and menu values.</p>
	<p>Touch these buttons to increase or decrease the value.</p>
	<p>Press Cancel to stop or suspend all job activity. The Cancel functions as a stop button.</p>
<p>Home</p> 	<p>Touch Home to return to the initial menu page.</p>
<p>Menus</p> 	<p>Press Menus to open the administration menus. These menus are only available when the printer is in the <i>Ready</i> state.</p>

Button or light	Function
	Press to return to the previous screen. Note: This button is only active if it appears on the bottom right of the screen.
	Continue.

Administrative Menu

Note: Some menu items may not be available based on the printer model or the options installed. Touch **Menu** () on the display to access these menus. To access the service menus, see **“Accessing test and diagnostic procedure menus” on page 3-1.**

Supplies Menu

Replace Supply
 Cyan Cartridge
 Magenta Cartridge
 Yellow Cartridge
 Black Cartridge
 Cyan PC Unit
 Magenta PC Unit
 Yellow PC Unit
 Black PC Unit
 Waste Toner Box
 Fuser
 Transfer Belt

Paper Menu

Default Source
 Paper Size/Type
 Configure MP
 Substitute Size
 Paper Texture
 Paper Weight
 Paper Loading
 Custom Types
 Universal Setup

Reports

Menu Settings Page
 Device Statistics
 Network Setup Page
 Network <x> Setup Page
 Wireless <x> Setup Page
 Profiles List
 NetWare Setup Page
 Print Fonts
 Print Demo

Settings

Setup Menu
 Finishing Menu
 Quality Menu
 Utilities Menu
 PDF Menu
 PostScript Menu
 PCL Emul Menu
 HTML Menu
 Image Menu

Security

Max Invalid PIN
 Job Expiration

Network/Ports

TCP/IP
 IPv6
 Wireless
 Standard Network
 Network <x>
 Standard USB
 USB <x>
 NetWare
 AppleTalk
 LexLink
 USB Direct

Help

Color Quality
 Print Quality
 Printing Guide
 Supplies Guide
 Media Guide
 Print Defects
 Menu Map
 Information Guide
 Connection Guide
 Moving Guide

Power-on self test (POST) sequence

When you turn the printer on, it performs a Power-On Self Test. Check for correct POST functioning of the base printer by observing the following:

1. The LED turns on.
2. The main fan turns on.
3. The operator panel turns on.
4. A partial row of pixels appears.
5. The operator panel display clears.
6. Another row of pixels appears.
7. The operator panel display clears again.
8. The operator panel displays system information. For example:

*256MB	500Mhz
--------	--------

9. The fuser lamp turns on. The fuser takes longer to warm up from a cold start than a warm start.
10. The operator panel LED starts blinking.
11. A clock face appears on the display.
The following errors or messages may appear:
 - Close Door or Insert Cartridge display if the upper front cover is open or the print cartridge is missing.
 - Any cartridge errors, such as Defective Cartridge or Missing Cartridge.
12. Ready appears on the display.
13. The main drive motor turns on.
14. The EP drive assembly drives the developer shaft located in the toner cartridge.
15. The exit rollers turn.
16. The printer calibrates.

Symptom tables

Printer symptom table

Symptom	Action
Dead printer	Go to “Dead printer service check” on page 2-140.
Operator panel—one or more buttons do not work.	Go to “One or more operator panel buttons fail” on page 2-145.
Operator panel—display is blank. Printer sounds five beeps.	Go to “Operator panel display blank, five beeps, and LED is off” on page 2-146.
Operator panel—display is blank.	Go to “Operator panel display blank, five beeps, and LED is off” on page 2-146.
Operator panel continuously displays all diamonds and does not complete POST.	Go to “Operator panel display blank, five beeps, and LED is off” on page 2-146.
Close Front Door does not appear when door is open	Go to “920.26—POST service check” on page 2-125.
Front door locks and will not open.	Go to “Front cover locked in place” on page 3-49.

Print quality symptom table

Symptom	Action
Background	Go to “Print quality—background” on page 2-148.
Blank page	Go to “Print quality—blank page” on page 2-149.
Blurred or fuzzy print	Go to “Print quality—blurred or fuzzy print” on page 2-150.
Half-color page	Go to “Print quality—half-color page” on page 2-150.
Horizontal banding	Go to “Print quality—horizontal banding” on page 2-150.
Horizontal line	Go to “Print quality—horizontal line” on page 2-151.
Insufficient fusing	Go to “Print quality—insufficient fusing” on page 2-151.
Missing image at edge	Go to “Print quality—missing image at edge” on page 2-151.
Mottle (2–5mm speckles)	Go to “Print quality—mottle (2–5mm speckles)” on page 2-151.
Narrow vertical line	Go to “Print quality—narrow vertical line” on page 2-151.
Random marks	Go to “Print quality—random marks” on page 2-151.
Residual image	Go to “Print quality—residual image” on page 2-152.
Solid color page	Go to “Print quality—solid color page” on page 2-152.
Vertical banding	Go to “Print quality—vertical banding” on page 2-153.
Small font text looks fuzzy around the edges	Check the flatbed air filter. If noticeable dirt or particles are on the filter, replace the filter. See “Flatbed air filter removal” on page 4-231.

User status and attendance messages

Error code	Action
Close Front Door	If you continuously get this error, then either 24 V interlock switch or 5 V interlock switch is bad. Go to “5 V interlock switch service check” on page 2-131 and “24 V interlock switch removal” on page 2-133 .
Close top access cover and front door Show me	Close the covers top access cover and front door securely. If you do not get a Close Top Access Cover when it is open, then go to “920.26—POST service check” on page 2-125 .
Disk Corrupted, Reformat?	The printer has attempted a disk recovery and cannot repair the disk. The disk must be formatted to use. Warning: All files stored on the disk will be lost.
Held Jobs May Not Be Restored	The printer has attempted to restore Held jobs, but not all were restored.
Insert Tray <x>	Insert tray to clear the message.
Load <source> <custom type name>	Load paper in the indicated source and of the indicated type. Additional messages may include: <ul style="list-style-type: none"> • Paper loaded—Touch Continue. • Show Me—the printer will present instructions. • Cancel Job—the printer job can be cancelled. • Wait for supplies—If job parking is enabled, and the job meets all the requirements for allowing the job to be parted, the printer adds this message.
Load <source> <Custom String>	Load paper in the indicated source, touch Continue . Additional messages may include: <ul style="list-style-type: none"> • Show Me—the printer will present instructions. • Cancel Job—the printer job can be cancelled. • Wait for supplies—If job parking is enabled, and the job meets all the requirements for allowing the job to be parted, the printer adds this message.
Load <source> <size>	Load paper in the indicated source and of the indicated size, touch Continue . Additional messages may include: <ul style="list-style-type: none"> • Show Me—the printer will present instructions. • Cancel Job—the printer job can be cancelled. • Wait for supplies—If job parking is enabled, and the job meets all the requirements for allowing the job to be parted, the printer adds this message.
Load Manual <custom type name>	If paper loaded is in the manual feeder, the job continues. If paper is not in the feeder, touching Select indicates to the printer it should search for a source with the proper custom type. Additional messages may include: <ul style="list-style-type: none"> • Show Me—the printer will present instructions. • Cancel Job—the printer job can be cancelled.
Load Manual <custom string>	If paper loaded is in the manual feeder, the job continues. If paper is not in the feeder, touching Select indicates to the printer it should search for a source with the proper custom string. Additional messages may include: <ul style="list-style-type: none"> • Show Me—the printer will present instructions. • Cancel Job—the printer job can be cancelled.



Error code	Action
Load Manual <size>	<p>If paper loaded is in the manual feeder, the job continues. If paper is not in the feeder, touching Select indicates to the printer it should search for a source with the proper size.</p> <p>Additional messages may include:</p> <ul style="list-style-type: none"> • Show Me—the printer will present instructions. • Cancel Job—the printer job can be cancelled.
Load Manual <type> <size>	<p>If paper loaded is in the manual feeder, the job continues. If paper is not in the feeder, touching Select indicates to the printer it should search for a source with the proper type and size.</p> <p>Additional messages may include:</p> <ul style="list-style-type: none"> • Show Me—the printer will present instructions. • Cancel Job—the printer job can be cancelled.
Paper Changes Needed	
PC Unit Exposure Warning	<p>This warning occurs when the front door is left open too long. Close the front door to prevent damage to the PC unit. Select Tell me more for further information.</p>
Remove All Color Supplies	<p>If Color Lockout mode is enabled, this message appears (unless the printer is in Diagnostics Menu or Configuration Menu).</p>
Remove Paper Standard Bin	<p>The standard output bin is full. Remove the media to continue.</p>
Remove Packaging Material	<p>If packaging material is detected by the printer, Check all areas, Check <area name>, or Check <number of> areas may appear. Touch Select to continue.</p>
Restore Held Jobs Go/Stop?	<p>If the printer detects Print and Hold (or parked) jobs stored on the hard disk during Power-On Self Test (POST). Choices are:</p> <ul style="list-style-type: none"> • Restore—Print jobs are restored, and Restoring Held Jobs x/y, where x is the number of the job restored and y is the total number of jobs to restore. You can quit restoring, and the remainder of the jobs will remain on the disk, but cannot be accessed until they are restored at the next POR. • Do not restore—Held jobs will remain on the disk, but cannot be accessed until they are restored at the next POR. Held jobs may not be restored appears. • Tell me more—additional information is available
Securely Clearing Disk Space	<p>Disk wiping process is recovering disk space. The message clears when all memory blocks are cleared.</p>
Tray Length Guide Missing	<p>Replace the tray length guide.</p>
Unsupported USB device, Please Remove	<p>Remove the unrecognized device to continue.</p>
Unsupported USB hub, Please Remove	<p>Remove the unrecognized device to continue.</p>
Unsupported Mode	<p>Unplug camera and change it to a mode where the camera can access PictBridge. Plug the camera back in to continue.</p>
Unsupported Disk	<p>Remove the unsupported disk to continue.</p>

Error code	Action
3x through 8x attendance messages	
31 Defective or Missing <color> Cartridge	<ul style="list-style-type: none"> • Reseat the specified toner cartridge. • Inspect the smart chip card contacts (A) for damage, contamination or positioning error. If damaged, contact your next level of service. <div data-bbox="764 428 1187 705" style="text-align: center;"> </div> <ul style="list-style-type: none"> • Inspect the toner cartridge contacts for damage/contamination. Replace the toner cartridge if defective. • Inspect the JSBTN1 cable connection. Properly connect the cable if not connected properly. Replace the cable if damaged. • Replace the indicated cartridge. • If the problem still exists, replace the system board. See “System board removal” on page 4-148.
32 Unsupported Cartridge	<ul style="list-style-type: none"> • Check to see if the toner cartridge is a supported cartridge. Note: Once the cartridge shipped with the printer is exhausted, it must be replaced by a supply cartridge (refer to the <i>User's Guide</i> for part numbers.) If the specified toner cartridge is a supported cartridge, reseat the cartridge. • Inspect the toner cartridge contacts for damage or contamination. Replace the toner cartridge if defective. • Inspect JSBTN1 cable connection. Properly connect the cable if not connected properly. Replace the cable if damaged. • If the problem still exists, replace the system board. See “System board removal” on page 4-148.
34 Short Paper	<ul style="list-style-type: none"> • Touch Continue to clear the message and continue printing. Note: The printer does not automatically reprint the page that prompted the message. • Check the tray length and width guides to ensure the media is properly fitted. • Make sure the print job is requesting the correct size of media. • Adjust the Paper Size setting for the media size being used. • If the MP Feeder Size is set to Universal, make sure the media is large enough for the formatted data. • Cancel the current job. Replace the paper pick mechanism. See “Paper pick mechanism assembly removal” on page 4-117. • If the problem still exists, replace the system board. See “System board removal” on page 4-148.
35 Insufficient memory to support Resource Save feature	<ul style="list-style-type: none"> • Touch Continue to disable Resource Save and continue printing. • To enable Resource Save after receiving this message: <ul style="list-style-type: none"> - Make sure the link buffers are set to Auto, then exit the menus to activate the link buffer changes. - When Ready is displayed, enable Resource Save. • Install additional memory. • If this does not fix the problem, replace the system board. See “System board removal” on page 4-148.

Error code	Action
37 Insufficient memory to collate job	<ul style="list-style-type: none"> • Touch Continue to print the portion of the job already stored and begin collating the rest of the job. • Cancel the current job. • If this does not fix the problem, replace the system board. See “System board removal” on page 4-148.
37 Insufficient memory for Flash Memory Defragment operation	<ul style="list-style-type: none"> • Touch Continue to stop the defragment operation and continue printing. • Delete fonts, macros, and other data in printer memory. • Install additional printer memory. • If this does not fix the problem, replace the system. See “System board removal” on page 4-148.
37 Insufficient memory, Some Held Jobs Were Not Restored	<ul style="list-style-type: none"> • The printer deleted some held jobs in order to process current jobs. • Touch Continue to clear the message. • If this does not fix the problem, replace the system board. See “System board removal” on page 4-148.
37 Insufficient memory, Some Held Jobs Will Not Be Restored	<ul style="list-style-type: none"> • The printer was unable to restore some or all of the confidential or held jobs on the hard disk. • Touch Continue to clear the message. • If this message occurs again, replace the hard drive. • If this does not fix the problem, replace the system board. See “System board removal” on page 4-148.
37 Insufficient Defrag Memory New	<p>There is insufficient memory to perform the Flash Memory Defragment operation. The user can:</p> <ul style="list-style-type: none"> • Delete font, macros, and other data in memory. • Install additional printer memory.
38 Memory Full	<p>The following options are available:</p> <ul style="list-style-type: none"> • Touch Continue to clear the message and continue printing. The job may not print correctly. • Cancel the current job. • Install additional printer memory. • If this does not fix the problem, replace the system board. See “System board removal” on page 4-148.
39 Complex Page	<p>The page is too complex to print. Options are:</p> <ul style="list-style-type: none"> • Touch Continue to continue. The job may not print correctly. • Cancel the job.
50 PPDS Font Error	<ul style="list-style-type: none"> • Touch Continue to clear the message and continue printing. The job may not print correctly. • Cancel the current job. • If this does not fix the problem, replace the system board. See “System board removal” on page 4-148.
51 Defective Flash	<ul style="list-style-type: none"> • Touch Continue to clear the message and continue printing. • Install different flash memory before downloading any resources to flash. • If this does not fix the problem, replace the system board. See “System board removal” on page 4-148.
52 Flash Full	<ul style="list-style-type: none"> • Touch Continue to clear the message and continue printing. • Note: Downloaded fonts and macros not previously stored in flash memory are deleted. • Delete fonts, macros, and other data stored in flash memory. • Install a larger capacity flash memory card. • If this does not fix the problem, replace the system board. See “System board removal” on page 4-148.

Error code	Action
53 Unformatted Flash	<ul style="list-style-type: none"> • Touch Continue to clear the message and continue printing. • Format the flash memory before storing any resources on it. If the error message remains, replace the flash memory. • If this does not fix the problem, replace the system board. See “System board removal” on page 4-148.
54 Serial option <x> error	<ul style="list-style-type: none"> • Make sure the serial link is set up correctly and the appropriate cable is in use. • Make sure the serial interface parameters (protocol, baud, parity, and data bits) are set correctly on the printer and host computer. • Touch Continue to clear the message and continue printing. The job may not print correctly. • POR the printer. If this does not fix the problem, replace the PCI card.
54 Std Network Software Error	<ul style="list-style-type: none"> • Touch Continue to clear the message and continue printing. The job may not print correctly. • Program new firmware for the network interface. • POR the printer. If this does not fix the problem, replace the PCI card.
55 Unsupported Option in Slot <x>	<ol style="list-style-type: none"> 1. Turn the printer off. 2. Unplug the power cord from the wall outlet. 3. Remove the unsupported option. 4. Connect the power cord to a properly grounded outlet. 5. Turn the printer on. <p>If this does not fix the problem, replace the system board. See “System board removal” on page 4-148.</p>
56 Standard Parallel Port Disabled Not in IRs	<ul style="list-style-type: none"> • Touch Continue to clear the message. The printer discards any data received through the parallel port. • Make sure the Parallel Buffer menu item is not set to <i>Disabled</i>. • If this does not fix the problem, replace the PCI card.
56 Parallel Port <x> Disabled	<ul style="list-style-type: none"> • Touch Continue to clear the message. The printer discards any data received through the parallel port. • Make sure the Parallel Buffer menu item is not set to <i>Disabled</i>. • If this does not fix the problem, replace the PCI card.
56 Serial Port <x> Disabled	<ul style="list-style-type: none"> • Touch Continue to clear the message. The printer discards any data received through the serial port. • Make sure the Serial Buffer menu item is not set to <i>Disabled</i>. • If this does not fix the problem, replace the PCI card.
56 Standard USB Port Disabled	<ul style="list-style-type: none"> • Touch Continue to clear the message. The printer discards any data received through the USB port. • Make sure the USB Buffer menu item is not set to <i>Disabled</i>. • If this does not fix the problem, replace the system board. See “System board removal” on page 4-148.
57 Configuration Change Held Jobs May Not Be Restored See Configuration Change, above - not in IR as 57	<p>Configuration changes may be:</p> <ul style="list-style-type: none"> • Code version changes • Paper handling options removed • The disk was installed from a different model or speed of printer.

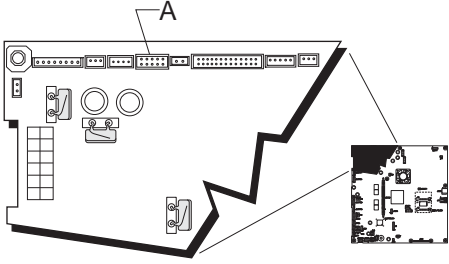
Error code	Action
58 Too Many Flash Options	<p>Too many flash options are installed. To continue:</p> <ol style="list-style-type: none"> 1. Turn off and unplug the printer. 2. Remove the excess flash memory. 3. Plug in the printer, and turn it on. <p>If this does not fix the problem, replace the system board. See “System board removal” on page 4-148.</p>
58 Too Many Trays Attached	<ol style="list-style-type: none"> 1. Turn off and unplug the printer. 2. Remove options until the supported number of options for that model. Models C734 supports three options and models C736 supports four options. 3. Plug in the printer, and turn it on. <p>If this does not fix the problem, replace the system board. See “System board removal” on page 4-148.</p>
59 Incompatible Tray <x>	<p>There is an incompatible tray. To remove the option:</p> <ol style="list-style-type: none"> 1. Turn off and unplug the printer. 2. Remove all option trays. 3. Install one option, plug in the printer and turn it on. 4. Continue adding one option at a time and checking whether the error occurs. 5. Install all options except the one identified as a problem. <ul style="list-style-type: none"> - If no problem occurs, replace the option. - If the same error occurs, replace the system board. 6. Plug in and power on
61 Defective Disk	<ul style="list-style-type: none"> • Touch Continue to clear the message and continue printing. • Install a different hard disk before performing any operations that require a hard disk. • If this does not fix the problem, replace the system board. See “System board removal” on page 4-148.
62 Disk full	<ul style="list-style-type: none"> • Touch Continue to clear the message and continue processing. • Note: Any information not previously stored on the hard disk is deleted. • Delete fonts, macros, and other data stored on the hard disk. • Install a larger hard disk. • If this does not fix the problem, replace the system board. See “System board removal” on page 4-148.
63 Unformatted disk	<ul style="list-style-type: none"> • Touch Continue to clear the message and continue printing. • Format the disk. • If the error message remains, replace the hard disk. • If this does not fix the problem, replace the system board. See “System board removal” on page 4-148.
64 Unsupported disk format	<ul style="list-style-type: none"> • Touch Continue to clear the message and continue printing. • Format the disk. • If the error message remains, replace the hard disk. • If this does not fix the problem, replace the system board. See “System board removal” on page 4-148.
80 Fuser Near Life Warning	<ul style="list-style-type: none"> • Touch Continue to clear the message and continue printing. • Show Me, View Supplies, and Tell Me More displays additional information. • Order a replacement fuser. When print quality is reduced, install the new fuser using the instruction sheet that comes with the replacement fuser. • Note: Be sure to reset the fuser count. See “Reset Fuser Count” on page 3-31. • If this does not fix the problem, replace the system board. See “System board removal” on page 4-148.

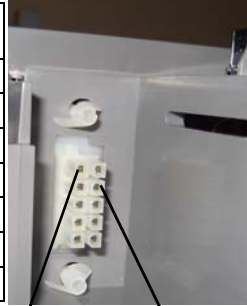
Error code	Action																
80 Fuser Life Warning	<ul style="list-style-type: none"> • Touch Continue to clear the message and continue printing. • Show Me, View Supplies, and Tell Me More displays additional information. • Order a replacement fuser. When print quality is reduced, install the new fuser using the instruction sheet that comes with the replacement fuser. • Note: Be sure to reset the fuser count. See “Reset Fuser Count” on page 3-31. • If this does not fix the problem, replace the system board. See “System board removal” on page 4-148. 																
80 Replace Fuser	<ul style="list-style-type: none"> • Show Me, View Supplies, and Tell Me More displays additional information. • Replace the fuser. • Note: Be sure to reset the fuser count. See “Reset Fuser Count” on page 3-31. • If this does not fix the problem, replace the system board. See “System board removal” on page 4-148. 																
80 Fuser Missing	<ul style="list-style-type: none"> • Reinstall the fuser. See “Fuser assembly removal” on page 4-94. • Reseat connectors behind fuser. They may get dislodged and not make good contact when the fuser is installed. • Check the cable connectors for damage at the system board and at the LVPS. 																
80.41 Fuser missing	<ul style="list-style-type: none"> • Install the fuser. Replace the fuser if the problem persists. • If the problem continues, turn the printer off and remove the rear frame cover. See “Rear frame cover removal” on page 4-38. Check the cable in connector JFUSER1 (A) for proper connection to the system board, the cable for pinch points, and the cable or the connector for any other damage. If the connector is damaged on system board, replace the system board. See “System board removal” on page 4-148. If the fuser cable is damaged, replace the cable. <div style="text-align: center;">  </div> <ul style="list-style-type: none"> • Check for the following continuity between the DC autoconnect and AC autoconnect (connected to JFUSER1 on the system board) <table border="1" style="margin-left: auto; margin-right: auto;"> <thead> <tr> <th data-bbox="630 1344 852 1648">AC auto-connect</th> <th data-bbox="852 1344 1079 1648">DC auto-connect</th> </tr> </thead> <tbody> <tr> <td data-bbox="630 1396 852 1438">Pin 1</td> <td data-bbox="852 1396 1079 1438">Pin 3</td> </tr> <tr> <td data-bbox="630 1438 852 1480">Pin 5</td> <td data-bbox="852 1438 1079 1480">Pin 4</td> </tr> <tr> <td data-bbox="630 1480 852 1522"></td> <td data-bbox="852 1480 1079 1522">Pin 6</td> </tr> <tr> <td data-bbox="630 1522 852 1564"></td> <td data-bbox="852 1522 1079 1564">Pin 7</td> </tr> <tr> <td data-bbox="630 1564 852 1606"></td> <td data-bbox="852 1564 1079 1606">Pin 8</td> </tr> <tr> <td data-bbox="630 1606 852 1648"></td> <td data-bbox="852 1606 1079 1648">Pin 9</td> </tr> <tr> <td data-bbox="630 1648 852 1690"></td> <td data-bbox="852 1648 1079 1690">Pin 10</td> </tr> </tbody> </table> <div style="display: flex; justify-content: space-around; margin-top: 10px;">   </div> <ul style="list-style-type: none"> • If continuity is not present, replace the fuser cable. If the problem persists after replacing cable, replace the system board. See “System board removal” on page 4-148. 	AC auto-connect	DC auto-connect	Pin 1	Pin 3	Pin 5	Pin 4		Pin 6		Pin 7		Pin 8		Pin 9		Pin 10
AC auto-connect	DC auto-connect																
Pin 1	Pin 3																
Pin 5	Pin 4																
	Pin 6																
	Pin 7																
	Pin 8																
	Pin 9																
	Pin 10																
82 Waste Toner Nearly Full	<ul style="list-style-type: none"> • Touch Continue to clear the message and continue printing. • If printing continues, order a replacement waste toner box immediately. • If the problem persists, open the front access door and check the aligner shaft for binding. Clear the binding if possible. If not possible, contact your next level of service. 																

Error code	Action
82 Replace Waste Toner	<ul style="list-style-type: none"> • Replace the waste toner box using the instruction sheet that comes with the replacement waste toner box. • Ensure that there is no interference between the waste toner box and the printer. • If the problem persists, open the front access door and check the aligner shaft for binding. Clear the binding if possible. • If the problem persists, replace the system board. See “System board removal” on page 4-148. • If the problem persists, contact your next level of service.
82 Waste Toner Missing	<ul style="list-style-type: none"> • Insert the waste toner box. • Inspect the top cover camshaft assembly for proper operation. When the top access cover is closed, the printer should mechanically interlock. • Check the cable on the system board for defects and proper connection. If the cable wiring or the cable connection is defective, replace the aligner motor. See “Multipurpose feeder (MPF)/duplex motor assembly removal” on page 4-110. If the cable is damaged on the system board, replace the system board. See “System board removal” on page 4-148. • Check the aligner shaft and the mechanical system for binds. • Replace the aligner motor. See “Multipurpose feeder (MPF)/duplex motor assembly removal” on page 4-110. • If the problem persists, replace the system board. See “System board removal” on page 4-148.
82.41	Aligner motor error. Go to “147.xx, 920.01—Motor (aligner) error service check” on page 2-55.
83.xx Transfer Module Life Warning	<ul style="list-style-type: none"> • Touch Continue to clear the message and continue printing. • Order a replacement transfer module. When print quality is reduced, install the new transfer module using the instruction sheet that comes with the replacement transfer module. • If the problem persists, replace the system board. See “System board removal” on page 4-148.
83 Replace Transfer Module	<ul style="list-style-type: none"> • Replace the transfer module using the instruction sheet that comes with the replacement transfer module. See “Transfer module removal” on page 4-168. • If the problem persists, replace the system board. See “System board removal” on page 4-148.
83.41 Transfer Module Missing	If you continuously get this error, then check the transfer module. Go to “920.03, 920.25—Transfer Module Missing error service check” on page 2-106.
84 <color> PC Unit Life Warning	<ul style="list-style-type: none"> • Touch Ignore to clear the message and continue printing. • Order the specified photoconductor unit. When print quality is reduced, install the new specified photoconductor unit using the instruction sheet that comes with the replacement specified photoconductor unit. • If the problem persists, replace the system board. See “System board removal” on page 4-148.
84 Replace <color> PC Unit	<ul style="list-style-type: none"> • Replace the specified photoconductor PC unit using the instruction sheet that comes with the replacement specified photoconductor unit. • If the problem persists, replace the system board. See “System board removal” on page 4-148.

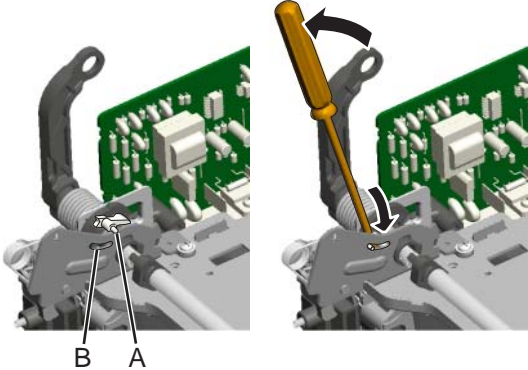
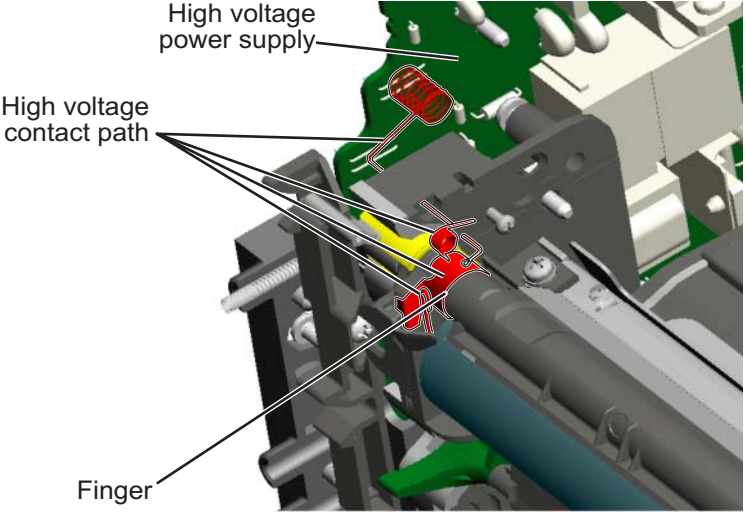
Error code	Action
84 <color> PC Unit Missing	<ul style="list-style-type: none"> • Scroll down the operator panel to see if the printer is showing that all four of the PC units are missing. If so, check the HVPS cable between the system board and the HVPS. Ensure that the cable is not plugged in backwards on the HVPS. Disconnect and reconnect the cable to make sure there is good contact. • Insert or reinstall the specified photoconductor unit and see if problem clears. See “Photoconductor unit removal” on page 4-124. • Remove the top access cover assembly (see “Top access cover assembly removal” on page 4-41), and confirm that the camshaft follower (A) on the left side is not out of the groove (B). If the camshaft follower is out of the groove, raise the arm, use a screwdriver to ease the camshaft follower back into the groove. You need to press down to <i>snap</i> it into position.  <ul style="list-style-type: none"> • Check the high voltage contacts path, especially the “finger” on the specified photoconductor unit (printer is shown with components removed for clarity).  <ul style="list-style-type: none"> • If the contacts are good, replace the HVPS. See “High-voltage power supply (HVPS) removal” on page 4-100. • If the problem persists, replace the system board. See “System board removal” on page 4-148.
84 <color> PC Unit Near Life Warning	<ul style="list-style-type: none"> • Touch Ignore to clear the message and continue printing. • Order the specified photoconductor unit. When print quality is reduced, install the new specified photoconductor unit using the instruction sheet that comes with the replacement specified photoconductor unit. • If the problem persists, replace the system board. See “System board removal” on page 4-148.

Error code	Action
88 <color> Cartridge Low	<ul style="list-style-type: none"> • Show Me, Vi ew Suppl i es, and Tel l Me More displays additional information. • Replace the specified toner cartridge. • Touch Continue to clear the message and continue printing. • If the problem persists, replace the system board. See “System board removal” on page 4-148.
88 <color> Cartridge Nearly Low	<ul style="list-style-type: none"> • Show Me, Vi ew Suppl i es, and Tel l Me More displays additional information. • Replace the specified toner cartridge. • Touch Continue to clear the message and continue printing. • If the problem persists, replace the system board. See “System board removal” on page 4-148.
88 Replace <color> Cartridge	<ul style="list-style-type: none"> • Show Me, Vi ew Suppl i es, and Tel l Me More displays additional information. • Replace the specified toner cartridge. • Touch Continue to clear the message and continue printing. • If the problem persists, replace the system board. See “System board removal” on page 4-148.

Error codes and messages

Error code	Description	Action
1xx service error codes		
110.01–110.07 Mirror Motor	A mirror motor error has occurred.	<ul style="list-style-type: none"> • POR the printer. • If the error message persists, go to “110.xx—Mirror motor service check” on page 2-40.
111.01–111.02 Printhead Error	An error has occurred in the cyan channel of the printhead.	<ul style="list-style-type: none"> • POR the printer. • If the error message persists, go to “111.xx, 112.xx, 113.xx, and 114.xx—Printhead error service check” on page 2-41.
112.01–112.02 Printhead Error	An error has occurred in the magenta channel of the printhead.	<ul style="list-style-type: none"> • POR the printer. • If the error message persists, go to “111.xx, 112.xx, 113.xx, and 114.xx—Printhead error service check” on page 2-41.
113.01–113.02 Printhead Error	An error has occurred in the yellow channel of the printhead.	<ul style="list-style-type: none"> • POR the printer. • If the error message persists, go to “111.xx, 112.xx, 113.xx, and 114.xx—Printhead error service check” on page 2-41.
114.01–114.02 Printhead Error	An error has occurred in the black channel of the printhead.	<ul style="list-style-type: none"> • POR the printer. • If the error message persists, go to “111.xx, 112.xx, 113.xx, and 114.xx—Printhead error service check” on page 2-41.
120.00–120.21 Fuser Error	An error has occurred in the fuser.	<ul style="list-style-type: none"> • Remove and reseal the fuser. See “Fuser assembly removal” on page 4-94. • POR the printer. • If the error message persists, go to “120.xx—Fuser error service check” on page 2-42.
140.01–140.10 Autocomp Motor Error	Tray 1 motor has failed.	<ul style="list-style-type: none"> • POR the printer. • If the error message persists, go to “140.xx, 920.02—Autocomp (tray 1) motor error service check” on page 2-46.
142.09–142.27 Motor Error	Fuser motor has failed.	<ul style="list-style-type: none"> • POR the printer. • If the error message persists, go to “142.xx, 906.01–906.04—Motor (fuser) error service check” on page 2-47.
143.09–143.27 Motor Error	EP Drive assembly cartridge 1 (top) motor has failed.	<ul style="list-style-type: none"> • POR the printer. • If the error message persists, go to “143.xx—Motor (EP drive assembly top cartridge) error service check” on page 2-48.
144.09–144.27 Motor Error	EP Drive assembly cartridge 2 (middle) motor has failed.	<ul style="list-style-type: none"> • POR the printer. • If the error message persists, go to “144.xx—Motor (EP drive assembly middle cartridge) error service check” on page 2-50.
145.09–145.27 Motor Error	EP drive assembly cartridge 3 (bottom) motor has failed.	<ul style="list-style-type: none"> • POR the printer. • If the error message persists, go to “145.xx—Motor (EP drive assembly bottom cartridge) error service check” on page 2-51.

Error code	Description	Action
146.01–146.08 Motor Error	Duplex motor has failed.	<ul style="list-style-type: none"> • POR the printer. • If the error message persists, go to “146.xx, 148.xx—Motor (MPF/duplex) error service check” on page 2-53.
147.09–147.25 Motor Error	Aligner motor has failed.	<ul style="list-style-type: none"> • POR the printer. • If the error message persists, go to “147.xx, 920.01—Motor (aligner) error service check” on page 2-55.
148.01–148.08 Motor Error	The multipurpose feeder motor has failed.	<ul style="list-style-type: none"> • POR the printer. • If the error message persists, go to “146.xx, 148.xx—Motor (MPF/duplex) error service check” on page 2-53.
155.01, 155.03 Motor Error	Cam motor failed.	<ul style="list-style-type: none"> • POR the printer. • If the error message persists, go to “155.xx—Cam motor error service check” on page 2-56.
156.01, 156.03 Motor Error	COD (Color On Demand) motor failed.	<ul style="list-style-type: none"> • POR the printer. • If the error message persists, go to “156.xx—COD (Color On Demand) motor error service check” on page 2-58.
160.01–160.06 Motor Error	Tray 2 pick motor failed.	<ul style="list-style-type: none"> • POR the printer. • If the message persists, go to “160.xx, 161.xx—Motor Error (option tray 2) service check” on page 2-60.
161.01–161.06 Motor Error	Tray 2 feed motor failed.	<ul style="list-style-type: none"> • POR the printer • If the message persists, go to “160.xx, 161.xx—Motor Error (option tray 2) service check” on page 2-60.
162.01–162.06 Motor Error	Tray 3 pick motor failed.	<ul style="list-style-type: none"> • POR the printer. • If the message persists, go to “162.xx, 163.xx—Motor (option tray 3) error service check” on page 2-61.
163.01–163.06 Motor Error	Tray 3 feed motor failed.	<ul style="list-style-type: none"> • POR the printer. • If the message persists, go to “162.xx, 163.xx—Motor (option tray 3) error service check” on page 2-61.
164.01–164.06 Motor Error	Tray 4 pick motor failed.	<ul style="list-style-type: none"> • POR the printer. • If the message persists, go to “164.xx, 165.xx—Motor Error (option tray 4) service check” on page 2-62.
165.01–165.06 Motor Error	Tray 4 feed motor failed.	<ul style="list-style-type: none"> • POR the printer. • If the message persists, go to “164.xx, 165.xx—Motor Error (option tray 4) service check” on page 2-62.
166.01–166.06 Motor Error	Tray 5 pick motor failed.	<ul style="list-style-type: none"> • POR the printer. • If the message persists, go to “166.xx, 167.xx—Motor Error (option tray 5) service check” on page 2-63.
167.01–167.06 Motor Error	Tray 5 feed motor failed.	<ul style="list-style-type: none"> • POR the printer. • If the message persists, go to “166.xx, 167.xx—Motor Error (option tray 5) service check” on page 2-63.

Error code	Description	Action
168.xx Motor Error	HCIT elevator motor error.	<ul style="list-style-type: none"> • POR the printer. • If the message persists, go to “168.xx—Motor (HCIT elevator) error service check” on page 2-64.
199.xx Software Error	Unrecoverable RIP software error.	<ul style="list-style-type: none"> • POR the printer. • If the error message persists, download the RIP code again.
2xx paper jam messages		
200.02	<p>Input sensor is made when printer tries to print from an idle state.</p> <p>Possible causes:</p> <ul style="list-style-type: none"> • Paper jam leaving page over sensor • Defective input sensor • Faulty system board 	<ul style="list-style-type: none"> • Clear away anything in the paper path that might cause the paper to jam. • If clearing a paper jam does not fix the problem, go to “Input sensor service check” on page 2-143.
200.11	<p>Input sensor does not break.</p> <p>Possible causes:</p> <ul style="list-style-type: none"> • Incorrect media setting • Incorrect paper loading • Incorrect media restraint setting • Transport belt module failure • Lower guide failure • Paper pick mechanism failure • Input sensor failure 	<ul style="list-style-type: none"> • Clear away anything in the paper path that might cause the paper to jam. • Ensure proper media is set for the type of paper used. • Fan media, and stack flat in the tray. • Properly set media restraints in the paper tray. • Check the pick tires and replace if worn. • If the message persists, go to “200.11, 250.03—Paper Jam error service check” on page 2-65.
200.17	<p>Input sensor is made when printer powers up or covers are closed.</p> <p>Possible causes:</p> <ul style="list-style-type: none"> • Paper jam leaving page over sensor • Defective input sensor • Faulty system board 	<ul style="list-style-type: none"> • Clear away anything in the paper path that might cause the paper to jam. • If clearing a paper jam does not fix the problem, go to “Input sensor service check” on page 2-143.
200.21	<p>Aligner motor stalled.</p> <p>Possible causes:</p> <ul style="list-style-type: none"> • Faulty cable/connector • 24 V interlock switch not working correctly • Faulty aligner motor • Faulty system board • Waste toner not seated. 	<ul style="list-style-type: none"> • Check that the waste toner is latched correctly in the printer. • Check for anything in the paper path that might cause the paper to jam. • If clearing a paper jam does not fix the problem, go to “147.xx, 920.01—Motor (aligner) error service check” on page 2-55.
200.22	<p>Pick (tray 1) motor stalled.</p> <p>Possible causes:</p> <ul style="list-style-type: none"> • Faulty cable/connector • Faulty pick motor • Faulty system board 	<ul style="list-style-type: none"> • Check for anything in the paper path that might cause the paper to jam. • If clearing a paper jam does not fix the problem, go to “140.xx, 920.02—Autocomp (tray 1) motor error service check” on page 2-46.

Error code	Description	Action
200.25	Input sensor is made when tray 1 is installed. Possible causes: <ul style="list-style-type: none"> • Improper placement of paper in tray 1 • Damaged input sensor flag or input sensor • Faulty system board 	<ul style="list-style-type: none"> • Fan media, and stack flat in the tray or multipurpose feeder. • Properly set media restraints in the paper tray. • If clearing a paper jam does not fix the problem, go to “Input sensor service check” on page 2-143.
200.30	Paper hit input sensor too soon. Possible causes: <ul style="list-style-type: none"> • Incorrect paper loading. • Damaged input sensor flag or input sensor. • Faulty system board. 	<ul style="list-style-type: none"> • Fan the media, and then stack flat in the tray. • Check for anything in the paper path that might cause the paper to jam. • The input sensor may not be functioning properly. Go to “Input sensor service check” on page 2-143.
201.02	Bubble sensor active when printing started. Possible causes: <ul style="list-style-type: none"> • Paper jam leaving page over sensor. • Damaged bubble sensor. • Damaged fuser autoconnect. • Faulty fuser DC cable connection. • Faulty fuser. • Faulty system board. 	<ul style="list-style-type: none"> • Clear away anything in the paper path that might cause the paper to jam. • Ensure proper media is set for the type of paper used. • Fan media, and stack flat in the tray. • Properly set media restraints in the paper tray. • If clearing a paper jam does not fix the problem, go to “Bubble sensor service check.” on page...
201.06	Paper is jammed between the input sensor and the exit sensor. Possible causes: <ul style="list-style-type: none"> • Damaged paper exit sensor or paper exit sensor flag • Transport belt module failure • Aligner failure • Damaged fuser autoconnect • Faulty fuser DC cable connection • Faulty fuser • Faulty system board 	<ul style="list-style-type: none"> • Check for anything in the paper path that might cause the paper to jam. • If the problem persists, go to “201.06, 201.31—Paper Jam error service check” on page 2-66.
201.07	Exit sensor is made early. Possible causes: <ul style="list-style-type: none"> • Damaged paper exit sensor or paper exit sensor flag • Damaged fuser autoconnect • Faulty fuser DC cable connection • Faulty fuser • Faulty system board 	<ul style="list-style-type: none"> • Check for anything in the paper path that might cause the paper to jam. • The fuser exit sensor may not be functioning properly. Go to “Exit sensor service check” on page 2-141.

Error code	Description	Action
201.08	Exit sensor is never made. Possible causes: <ul style="list-style-type: none"> • Improper loading • Paper wrapped in fuser • Damaged paper exit sensor or paper exit sensor flag • Damaged fuser autoconnect • Faulty fuser DC cable connection • Faulty fuser • Faulty system board 	<ul style="list-style-type: none"> • Check for anything in the paper path that might cause the paper to jam. • The fuser exit sensor may not be functioning properly. Go to “Exit sensor service check” on page 2-141.
201.10	Input sensor flag broke early. Possible causes: <ul style="list-style-type: none"> • Incorrect media set • Defective input sensor • Faulty system board 	<ul style="list-style-type: none"> • Check for anything in the paper path that might cause the paper to jam. • Ensure the proper media is set for the type of paper used. • If the problem persists, go to “Input sensor service check” on page 2-143.
201.17	Power up or cover closed with bubble sensor active. Possible causes: <ul style="list-style-type: none"> • Paper jam leaving page over sensor. • Damaged bubble sensor. • Damaged fuser autoconnect. • Faulty fuser DC cable connection. • Faulty fuser. • Faulty system board. 	<ul style="list-style-type: none"> • Ensure the proper media is set for the type of paper used. • Fan the media, and stack flat in the tray or multipurpose feeder. • Properly set media restraints in the paper tray. • Clear away anything in the paper path that might cause the paper to jam. • If clearing a paper jam does not fix the problem, go to “Bubble sensor service check” on page 2-138.
201.21	Cartridge motor 1 (top) or cartridge motor 2 (middle) has stalled. Possible causes: <ul style="list-style-type: none"> • Faulty cable/connector • Faulty cartridge motor • Faulty system board 	<ul style="list-style-type: none"> • Check for anything in the paper path that might cause the paper to jam. • If clearing a paper jam does not fix the problem, go to “143.xx—Motor (EP drive assembly top cartridge) error service check” on page 2-48 and then go to “144.xx—Motor (EP drive assembly middle cartridge) error service check” on page 2-50 if necessary.
201.24	A 201.08 jam occurred and was not cleared. Possible cause—Failure to open and close the top access door.	This error is generated as a protection for possible paper wrap in the fuser. <ul style="list-style-type: none"> • Open the top access door, and check for a paper jam. Close the top access door. • If the problem persists, go to “Exit sensor service check” on page 2-141.
201.31	Paper is jammed between the input sensor and the exit sensor during warm-up. Possible causes: <ul style="list-style-type: none"> • Damaged paper exit sensor or paper exit sensor flag. • Transport belt module failure. • Lower guide failure • Damaged fuser autoconnect. • Faulty fuser DC cable connection. • Faulty fuser. • Faulty system board. 	<ul style="list-style-type: none"> • Check for anything in the paper path that might cause the paper to jam. • If the problem persists, go to “201.06, 201.31—Paper Jam error service check” on page 2-66.

Error code	Description	Action
202.02	Exit sensor is made when printer tries to print from an idle state. Possible causes: <ul style="list-style-type: none"> • Damaged paper exit sensor or paper exit sensor flag • Damaged fuser autoconnect • Faulty fuser DC cable connection • Faulty fuser • Faulty system board 	<ul style="list-style-type: none"> • Check for anything in the paper path that might cause the paper to jam. • The fuser exit sensor may not be functioning properly. Go to “Exit sensor service check” on page 2-141.
202.12	Exit sensor broke early. Possible causes: <ul style="list-style-type: none"> • Damaged paper exit sensor or paper exit sensor flag • Faulty fuser • Faulty system board 	The fuser exit sensor may not be functioning properly. Go to “Exit sensor service check” on page 2-141.
202.13	Exit sensor never broke. Possible causes: <ul style="list-style-type: none"> • Damaged paper exit sensor or paper exit sensor flag • Faulty fuser • Faulty system board • Faulty output bin flag 	<ul style="list-style-type: none"> • Check exit sensor flag on fuser for proper operation. Ensure that paper is not hanging on the flag. • The fuser exit sensor may not be functioning properly. Go to “Exit sensor service check” on page 2-141.
202.17	Exit sensor is made when the printer powers up or covers are closed. Possible causes: <ul style="list-style-type: none"> • Damaged paper exit sensor or paper exit sensor flag • Damaged fuser autoconnect • Faulty fuser DC cable connection • Faulty fuser • Faulty system board 	<ul style="list-style-type: none"> • Check for anything in the paper path that might cause the paper to jam. • The fuser exit sensor may not be functioning properly. Go to “Exit sensor service check” on page 2-141.
202.21	Fuser motor stalled. Possible causes: <ul style="list-style-type: none"> • Faulty cable/connector • Faulty fuser motor • Faulty system board 	<ul style="list-style-type: none"> • Check for anything in the paper path that might cause the paper to jam. • If clearing a paper jam does not fix the problem, go to “142.xx, 906.01–906.04—Motor (fuser) error service check” on page 2-47.
202.31	Paper jam at exit sensor during warm-up. Possible causes: <ul style="list-style-type: none"> • Damaged paper exit sensor or paper exit sensor flag. • Damaged fuser autoconnect. • Faulty fuser DC cable connection. • Faulty fuser. • Faulty system board. 	<ul style="list-style-type: none"> • Check for anything in the paper path that might cause the paper to jam. • The fuser exit sensor may not be functioning properly. Go to “Exit sensor service check” on page 2-141.

Error code	Description	Action
203.09	<p>During duplex printing retract, the exit sensor is never made.</p> <p>Possible causes:</p> <ul style="list-style-type: none"> • Damaged paper exit sensor or paper exit sensor flag • Transport belt module failure • Damaged fuser autoconnect • Faulty fuser DC cable connection • Faulty fuser • Faulty system board 	<ul style="list-style-type: none"> • Check for anything in the paper path that might cause the paper to jam. • The fuser exit sensor may not be functioning properly. Go to “203.09—Paper Jam error service check” on page 2-69.
203.14	<p>During duplex printing retract, the exit sensor broke early.</p> <p>Possible causes:</p> <ul style="list-style-type: none"> • Incorrect paper settings • Damaged paper exit sensor or paper exit sensor flag • Faulty fuser • Faulty system board 	<ul style="list-style-type: none"> • Ensure proper media is set for the type of paper used. • The fuser exit sensor may not be functioning properly. Go to “Exit sensor service check” on page 2-141.
203.15	<p>During duplex printing, the exit sensor never broke.</p> <p>Possible causes:</p> <ul style="list-style-type: none"> • Damaged paper exit sensor or paper exit sensor flag • Obstructed duplex • Faulty fuser • Faulty system board • Duplex motor failure 	<ul style="list-style-type: none"> • Check the duplex paper path for damage that would obstruct the print. If damage is found, replace the front door assembly. See “Front door assembly removal” on page 4-83. • The fuser exit sensor may not be functioning properly. Go to “Exit sensor service check” on page 2-141. • The duplex motor may not be functioning properly. Go to “146.xx, 148.xx—Motor (MPF/duplex) error service check” on page 2-53.
203.20	<p>During duplex, the page made the input sensor before the previous page cleared the bubble sensor.</p> <p>Possible causes:</p> <ul style="list-style-type: none"> • Defective input sensor. • Faulty system board. 	<ul style="list-style-type: none"> • Check for anything in the duplex paper path that might cause the paper to jam. This includes the paper guides in tray 1. • If clearing the paper jam does not fix the problem and the paper is fan-folded, replace the front access assembly. See “Front door assembly removal” on page 4-83. • If clearing a paper jam does not fix the problem, go to “Input sensor service check” on page 2-143.
230.03	<p>During duplex printing, the input sensor is never broke.</p> <p>Possible causes:</p> <ul style="list-style-type: none"> • Obstructed duplex path • Duplex drive failure • Defective input sensor • Faulty system board 	<ul style="list-style-type: none"> • Check for anything in the duplex paper path that might cause the paper to jam. This includes the paper guides in tray 1. • If the problem persists, go to “230.03, 230.05—Paper Jam error service check” on page 2-71.
230.05	<p>During duplex printing, the input sensor is not made.</p> <p>Possible causes:</p> <ul style="list-style-type: none"> • Obstructed duplex path • Defective input sensor • Faulty system board • Faulty duplex drive 	<ul style="list-style-type: none"> • Check for anything in the duplex paper path that might cause the paper to jam. This includes the paper guides in tray 1. • If the problem persists, go to “230.03, 230.05—Paper Jam error service check” on page 2-71.

Error code	Description	Action
230.21	Duplex motor stalled. Possible causes: <ul style="list-style-type: none"> • Obstructed duplex path • Defective duplex motor • Faulty system board 	<ul style="list-style-type: none"> • Check for anything in the duplex paper path that might cause the paper to jam. This includes the paper guides in tray 1. • If clearing a paper jam does not fix the problem, go to “146.xx, 148.xx—Motor (MPF/duplex) error service check” on page 2-53.
241.03	While feeding from tray 1, the input sensor does not break. Possible causes: <ul style="list-style-type: none"> • Incorrect media setting • Incorrect paper loading • Incorrect media restraint setting • Paper pick mechanism failure • Transport belt motor failure 	<ul style="list-style-type: none"> • Clear away y anything in the paper path that might cause the paper to jam. • Ensure proper media is set for the type of paper used. • Fan media, and stack it flat in the tray or multipurpose feeder. • Properly set media restraints in paper tray. • Check the pick tires and replace if worn. • If the problem persists, go to “200.11, 250.03—Paper Jam error service check” on page 2-65.
241.05	While feeding from tray 1, the input sensor is never made. Possible causes: <ul style="list-style-type: none"> • Incorrect paper loading • Incorrect media restraint setting • Pick art rolls (tires) failure • Paper pick mechanism failure • System board failure 	<ul style="list-style-type: none"> • Remove all media present in the paper path. • Fan media, and stack it flat in the tray or multipurpose feeder. • Properly set media restraints in paper tray. • Check the pick tires and replace if worn. • If the problem persists, go to “140.xx, 920.02—Autocomp (tray 1) motor error service check” on page 2-46.
241.21	Tray 1 motor stalled. Possible causes: <ul style="list-style-type: none"> • Incorrect paper loading • Paper pick mechanism failure • System board failure 	<ul style="list-style-type: none"> • Remove all media present in the paper path. • Ensure proper media is set for the type of paper used. • Fan media, and stack it flat in the tray or multipurpose feeder. • If the previous actions do not fix the problem, go to “140.xx, 920.02—Autocomp (tray 1) motor error service check” on page 2-46.
242.02	Tray 2 pass thru sensor made at POR. Possible causes: <ul style="list-style-type: none"> • Paper jam leaving paper over sensor • Defective pass thru sensor 	<ul style="list-style-type: none"> • Check for anything in the paper path that might cause the paper to jam. • If the error persists, go to “242.02—Paper Jam error service check” on page 2-73.
242.03	Pick timeout from tray 2 exceeded without a tray 2 sensor break. Possible causes: <ul style="list-style-type: none"> • Incorrect media setting • Incorrect paper loading • Incorrect media restraint setting • Tray 2 assembly failure • Aligner failure • Transport belt module failure 	<ul style="list-style-type: none"> • Remove all media present in the paper path. • Ensure proper media is set for the type of paper used in tray 2. • Fan media, and stack flat in tray 2. • Properly set media restraints in tray 2. • If the paper jam message persists, go to “242.03, 242.11—Paper Jam service check” on page 2-74

Error code	Description	Action
242.05	Tray 2 picked, but page failed to reach the option sensor in time. Possible causes: <ul style="list-style-type: none"> • Incorrect media setting • Incorrect paper loading • Incorrect media restraint setting • Faulty paper pick mechanism 	<ul style="list-style-type: none"> • Ensure proper media is set for the type of paper used in tray 2. • Fan media, and stack flat in tray 2. • Properly set the media restraints in tray 2. • Check the pick tires in tray 2 and replace if worn. • If the previous actions do not fix the problem, go to “242.05—Paper Jam service check” on page 2-75.
242.10	Tray 2 page exits pass thru made early. Possible causes: <ul style="list-style-type: none"> • Defective pass thru sensor • Faulty cable in the connector OPT1 on system board. 	<ul style="list-style-type: none"> • Ensure the proper media is set for the type of paper used in tray 2. • Check for anything in the paper path that might cause the paper to jam. • The exits pass thru sensor may not be functioning properly. Go to “242.10—Paper Jam service check” on page 2-76.
242.11	Tray 2 sensor never broke. Possible causes: <ul style="list-style-type: none"> • Incorrect tray 2 media setting • Incorrect Tray 2 paper loading • Incorrect media restraint setting • Paper tray failure • Aligner failure • Transport belt module failure • Loading card stock from the special media tray above the fill line. • High humidity (replace paper) 	<ul style="list-style-type: none"> • Ensure the proper media is set for the type of paper used in tray 2. • Fan media, and then stack flat in tray 2. • Properly set the media restraints in tray 2. • If the problem persists, go to “242.03, 242.11—Paper Jam service check” on page 2-74.
242.17	Tray 2 detected a jam from idle. Possible causes: <ul style="list-style-type: none"> • Paper jam leaving page over sensor • Defective input sensor • Faulty system board 	<ul style="list-style-type: none"> • Clear away anything in the paper path that might cause the paper to jam. • If clearing a paper jam does not fix the problem, go to “242.17—Paper Jam service check” on page 2-77.
242.26	While feeding from tray 2, the pass thru sensor is not made. Possible causes: <ul style="list-style-type: none"> • Incorrect paper loading for lower tray • Incorrect media restraint setting for lower tray • Paper tray 2 assembly failure • Lower tray 3 assembly failure 	<ul style="list-style-type: none"> • Clear away anything in the paper path that might cause the paper to jam. • Ensure the proper media is set for the type of paper used in the lower tray. • Fan the media, and then stack flat in the lower tray. • Properly set the media restraints in the lower tray. • Check the pick tires in the lower tray, and then replace if worn. • If clearing a paper jam does not fix the problem, go to “242.26—Paper Jam service check” on page 2-78.
242.27	While feeding from a lower tray, the pass thru sensor did not break. Possible causes: <ul style="list-style-type: none"> • Paper tray 2 assembly failure (feed thru roller) • Aligner failure • Transport belt motor failure 	<ul style="list-style-type: none"> • Clear away anything in the paper path that might cause the paper to jam. • Reseat option tray 2. • If the problem persists, go to “242.27—Paper Jam service check” on page 2-78.

Error code	Description	Action
242.29	Tray 2 is not ready or missing while printing. Possible cause is paper tray 2 assembly failure:	<ul style="list-style-type: none"> • Make sure that tray 2 is correctly inserted. • If the problem persists, go to “242.29—Paper Jam service check” on page 2-79.
243.02	Tray 3 pass thru sensor made at POR. Possible causes: <ul style="list-style-type: none"> • Paper jam leaving page over the sensor • Defective pass thru sensor 	<ul style="list-style-type: none"> • Check for anything in the paper path that might cause the paper to jam. • If clearing a paper jam does not fix the problem, go to “243.02—Paper Jam service check” on page 2-79.
243.03	Pick timeout from tray 3 exceeded without a tray 3 sensor break. Possible causes: <ul style="list-style-type: none"> • Tray 3 incorrect media setting • Tray 3 incorrect paper loading • Tray 3 incorrect media restraint setting • Tray 3 assembly failure 	<ul style="list-style-type: none"> • Remove all media present in the paper path. • Ensure proper media is set for the type of paper used in tray 3. • Fan media, and stack flat in tray 3. • Properly set media restraints in tray 3. • If the previous actions do not fix the problem, go to “243.03, 243.11—Paper Jam service check” on page 2-81.
243.05	Tray 3 picked, but page failed to reach the option sensor in time. Possible causes: <ul style="list-style-type: none"> • Tray 3 incorrect media setting • Tray 3 incorrect paper loading • Tray 3 incorrect media restraint setting • Tray 3 paper pick mechanism failure • Loading card stock from the special media tray above the till line. 	<ul style="list-style-type: none"> • Ensure proper media is set for the type of paper used in tray 3. • Fan media, and stack flat in tray 3. • Properly set the media restraints in tray 3. • Check the pick tires in tray 3 and replace if worn. • If the previous actions do not fix the problem, go to “243.05—Paper Jam service check” on page 2-82.
243.10	Tray 3 page exits pass thru sensor broken early. Possible causes: <ul style="list-style-type: none"> • Defective pass thru sensor • Faulty cable in connector OPT1 	<ul style="list-style-type: none"> • Make sure the proper media is set for the type of paper used in tray 3. • Check for anything in the paper path that might cause the paper to jam. • The exit pass thru sensor may not be functioning properly. Go to “243.10—Paper Jam service check” on page 2-83.
243.11	Tray 3 sensor never broke. Possible causes: <ul style="list-style-type: none"> • Incorrect tray 3 media setting • Incorrect tray 3 paper loading • Incorrect media restraint setting • Paper tray failure • Aligner failure • Transport belt module failure • Loading card stock from the special media tray above the fill line. • High humidity (replace paper) 	<ul style="list-style-type: none"> • Ensure the proper media is set for the type of paper used in tray 3. • Fan media, and then stack flat in tray 3. • Properly set the media restraints in tray 3. • Check the pick tires in tray 3 and replace if worn. • If the problem persists, Go to “243.03, 243.11—Paper Jam service check” on page 2-81.

Error code	Description	Action
243.17	Tray 3 detected a jam from idle. Possible causes: <ul style="list-style-type: none"> • Paper jam leaving page over sensor • Defective input sensor • Faulty system card 	<ul style="list-style-type: none"> • Clear away anything in the paper path that might cause the media to jam. • If the problem persists, go to “243.17—Paper Jam service check” on page 2-84.
243.26	While feeding from a lower tray, tray 3 pass thru sensor is not made. Possible causes: <ul style="list-style-type: none"> • Incorrect paper loading for lower tray • Incorrect media restraint setting for lower tray • Paper tray 3 assembly failure • Lower tray 4 assembly failure 	<ul style="list-style-type: none"> • Clear away anything in the paper path that might cause the media to jam. • Make sure proper media is set for the type of paper used in lower feeding tray. • Fan media, and stack flat in the lower feeding tray. • Properly set media restraints in the lower feeding tray. • Check the pick tires in lower tray and replace if worn. • If the problem persists, go to “243.26—Paper Jam service check” on page 2-85.
243.27	While feeding from a lower tray, tray 3 pass thru sensor did not break. Possible cause is a paper tray 3 assembly failure	<ul style="list-style-type: none"> • Clear away anything in the paper path that might cause the paper to jam. • Reseat option tray 3 • If the problem persists, go to “243.27—Paper Jam service check” on page 2-85.
243.29	Tray 3 is not ready while printing. Possible cause is paper tray 3 assembly failure.	<ul style="list-style-type: none"> • Make sure that tray 3 is correctly inserted. • If the problem persists, go to “243.29—Paper Jam service check” on page 2-85.
244.02	Tray 4 pass thru sensor made at POR. Possible causes: <ul style="list-style-type: none"> • Paper jam leaving page over the sensor • defective pass thru sensor 	<ul style="list-style-type: none"> • Check for anything in the paper path that might cause the paper to jam. • If the problem persists, go to “244.02—Paper Jam service check” on page 2-86.
244.03	Pick timeout from tray 4 was exceeded without a tray 4 sensor break. Possible causes: <ul style="list-style-type: none"> • Tray 4 incorrect media setting • Tray 4 incorrect paper loading • Tray 4 incorrect media restraint setting • Tray 4 assembly failure • Aligner failure • Transport belt module failure 	<ul style="list-style-type: none"> • Remove all media present in the paper path. • Make sure proper media is set for the type of paper used in tray 4. • Fan the media, and stack flat in tray 4. • Properly set media restraints in tray 4. • If the problem persists, go to “244.03, 244.11—Paper Jam service check” on page 2-87.

Error code	Description	Action
244.05	<p>Tray 4 picked, but page failed to reach the option sensor in time.</p> <p>Possible causes:</p> <ul style="list-style-type: none"> • Tray 4 incorrect media setting • Tray 4 incorrect paper loading • Tray 4 incorrect media restraint setting • Tray 4 paper pick mechanism assembly failure • Loading card stock from the special media tray above the fill line. 	<ul style="list-style-type: none"> • Ensure proper media is set for the type of paper used in tray 4. • Fan media, and stack flat in tray 4. • Properly set the media restraints in tray 4. • Check the pick tires in tray 4 and replace if worn. • If the problem persists, go to “244.05—Paper Jam service check” on page 2-88.
244.10	<p>Tray 4 page exit pass thru made early.</p> <p>Possible causes:</p> <ul style="list-style-type: none"> • Defective pass thru sensor • Faulty cable in connector OPT1 	<ul style="list-style-type: none"> • Make sure proper media is set for the type of paper used in tray 4. • Check for anything in the paper path that might cause the paper to jam. • The exit pass thru sensor may not be functioning properly. Go to “244.10—Paper Jam service check” on page 2-89.
244.11	<p>Tray 4 sensor never broke.</p> <p>Possible causes:</p> <ul style="list-style-type: none"> • Incorrect tray 4 media setting • Incorrect tray 4 paper loading • Incorrect media restraint setting • Paper tray failure • Aligner failure • Transport belt module failure • Loading card stock from the special media tray above the fill line. • High humidity (replace paper) 	<ul style="list-style-type: none"> • Ensure the proper media is set for the type of paper used in tray 4. • Fan media, and then stack flat in tray 4. • Properly set the media restraints in tray 4. • If the problem persists, go to “244.03, 244.11—Paper Jam service check” on page 2-87.
244.17	<p>Tray 4 detected a jam from idle.</p> <p>Possible causes:</p> <ul style="list-style-type: none"> • Paper jam leaving page over the sensor • defective input sensor • Faulty system board 	<ul style="list-style-type: none"> • Clear away anything in the paper path that might cause the paper to jam. • If clearing a paper jam does not fix the problem, go to “244.17—Paper Jam service check” on page 2-90.
244.26	<p>While feeding from a lower tray, tray 4 pass thru sensor is not made.</p> <p>Possible causes:</p> <ul style="list-style-type: none"> • Incorrect paper loading for the lower tray • Incorrect media restraint setting for the lower tray • Paper tray 4 assembly failure • Paper tray 5 assembly failure 	<ul style="list-style-type: none"> • Clear away anything in the paper path that might cause the paper to jam. • Make sure the proper media is set for the type of paper used in the lower tray. • Fan the media, and stack flat in the lower tray. • Properly set the media restraints in the lower tray. • Check the pick tires in the lower feeding tray and replace if worn. • If the problem persists, go to “244.26—Paper Jam service check” on page 2-91.
244.27	<p>While feeding from a lower tray, tray 4 pass thru sensor did not break.</p> <p>Possible cause is paper tray 4 assembly failure.</p>	<ul style="list-style-type: none"> • Clear away anything in the paper path that might cause the paper to jam. • Reseat option tray 4. • If the problem persists, go to “244.27—Paper Jam service check” on page 2-91.

Error code	Description	Action
244.29	Tray 4 is not ready, or missing while printing. Possible cause is paper tray 4 assembly failure.	<ul style="list-style-type: none"> • Make sure that tray 4 is correctly inserted. • If the problem persists, go to “244.29—Paper Jam service check” on page 2-91.
245.02	Tray 5 pass thru sensor made at POR. Possible causes: <ul style="list-style-type: none"> • Paper jam leaving a page over the sensor • Defective pass thru sensor 	<ul style="list-style-type: none"> • Check for anything in the paper path that might cause the media to jam. • If the problem persists, go to “245.02—Paper Jam service check” on page 2-92.
245.03	Pick timeout from tray 5 exceeded without a tray sensor break. Possible causes: <ul style="list-style-type: none"> • Tray 5 incorrect media setting • Tray 5 incorrect paper loaded • Tray 5 incorrect media restraint setting • Tray 5 assembly failure • Aligner failure • Transport belt module failure 	<ul style="list-style-type: none"> • Remove all media present in the paper path. • Make sure proper media is set for the type of paper used in tray 5. • Fan the media, and stack flat in tray 5. • Properly set the media restraints in tray 5. • If the problem persists, go to “245.03, 245.11—Paper Jam service check” on page 2-93.
245.05	Possible causes: <ul style="list-style-type: none"> • Incorrect media setting • Incorrect paper loading • Incorrect media restraint setting • Tray 5 paper pick mechanism • Loading card stock from the special media tray above the fill line. 	<ul style="list-style-type: none"> • Ensure proper media is set for the type of paper used in tray 5. • Fan media, and stack flat in tray 5. • Properly set the media restraints in tray 5. • Check the pick tires in tray 5 and replace if worn. • If the problem persists, go to “245.05—Paper Jam service check” on page 2-94.
245.10	Tray 5 page exits pass thru sensor broken early. Possible causes: <ul style="list-style-type: none"> • Defective pass thru sensor • Faulty cable in connector JOPT1 on the system board 	<ul style="list-style-type: none"> • Make sure the proper media is set for the type of paper used in tray 5. • Check for anything in the paper path that might cause the paper to Jam. • The exits pass thru sensor may not be functioning properly. Go to “245.10—Paper Jam service check” on page 2-95.
245.11	Tray 5 sensor never broke. Possible causes: <ul style="list-style-type: none"> • Incorrect tray 5 media setting • Incorrect tray 5 paper loading • Incorrect media restraint setting • Paper tray failure • Aligner failure • Transport belt module failure • Loading card stock from the special media tray above the fill line. • High humidity (replace paper) 	<ul style="list-style-type: none"> • Ensure the proper media is set for the type of paper used in tray 5. • Fan media, and then stack flat in tray 5. • Properly set the media restraints in tray 5. • Check the pick tires in tray 5 and replace if worn. • If the problem persists, go to “245.03, 245.11—Paper Jam service check” on page 2-93.

Error code	Description	Action
245.17	Tray 5 detected a jam from idle. Possible causes: <ul style="list-style-type: none"> • Paper jam leaves a page over the sensor • Defective input sensor • Faulty system board 	<ul style="list-style-type: none"> • Clear away anything in the paper path that might cause the paper to jam. • If the problem persists, go to “245.17—Paper Jam service check” on page 2-96.
245.29	Tray 5 is not ready or missing while printing. Possible cause paper is a tray 5 assembly failure.	<ul style="list-style-type: none"> • Make sure that tray 5 is correctly inserted. • If the problem persists, go to “245.29—Paper Jam service check” on page 2-97.
250.03	While feeding from the multipurpose feeder, the input sensor did not break. Possible causes: <ul style="list-style-type: none"> • Incorrect media setting • Incorrect paper loading • Incorrect media restraint setting • Transport belt failure • Paper tray failure 	<ul style="list-style-type: none"> • Remove all media present in the paper path. • Ensure proper media is set for the type of paper used. • Fan media, and stack it flat in the tray or multipurpose feeder. • Properly set media restraints in the paper tray. • Check the multipurpose feeder pick tires, and then clean if necessary. • Replace the paper tray. • If the problem persists, go to “200.11, 250.03—Paper Jam error service check” on page 2-65.
250.05	While feeding from the multipurpose feeder, the input sensor is not made. Possible causes: <ul style="list-style-type: none"> • Incorrect media setting • Incorrect paper loading • Incorrect media restraint setting • Multipurpose feeder pick mechanism failure • System board failure 	<ul style="list-style-type: none"> • Remove all the media present in the paper path. • Ensure proper media is set for the type of paper used. • Fan media, and stack it flat in the tray or multipurpose feeder. • Properly set media restraints in the paper tray. • Check the multipurpose feeder pick tires, and then clean if necessary. • Replace the paper tray.
250.21	Multipurpose feeder motor stalled. Possible causes: <ul style="list-style-type: none"> • Multipurpose motor failure • cabling failure • MPF gear assembly failure • System board failure 	<ul style="list-style-type: none"> • Remove all the media present in the paper path. • Ensure proper media is set for the type of paper used. • Fan media, and stack it flat in the tray or multipurpose feeder. • If the previous actions do not fix the problem, go to “146.xx, 148.xx—Motor (MPF/duplex) error service check” on page 2-53.
290.00	Scanner Static Jam—ADF skew sensor	<ul style="list-style-type: none"> • Remove all media present in media path. • Check the ADF skew sensor for proper operation. Go to “ADF skew sensor service check” on page 2-137.
290.01	Scanner Static Jam—ADF pickup jam	<ul style="list-style-type: none"> • Remove all media present in the media path. • Check for obstructions in the media path. • If the problem persists, go to “290.01, 290.02—Scanner ADF pickup/feed jam service check” on page 2-97.

Error code	Description	Action
290.02	Scanner ADF feed jam.	<ul style="list-style-type: none"> Remove all media present in the media path. Check for obstructions in the media path. If the problem persists, go to “290.01, 290.02—Scanner ADF pickup/feed jam service check” on page 2-97
290.10	Scanner static jam—scanning sensor.	<ul style="list-style-type: none"> Remove all media present in media path. Check ADF scanning sensor for proper operation. Go to “ADF scanning sensor service check” on page 2-138.
291.00	Scanner static jam—jam sensor.	<ul style="list-style-type: none"> Remove all media present in media path. Check ADF jam sensor for proper operation. Go to “ADF jam sensor service check” on page 2-136.
291.01	ADF scanning sensor jam. Possible cause is sensor never made.	<ul style="list-style-type: none"> Remove all media present in the media path. Check for obstructions in the media path. Check the ADF jam sensor for proper operation. Go to “ADF jam sensor service check” on page 2-136.
291.02	ADF jam sensor jam.	Go to “ADF jam sensor service check” on page 2-136.
292.00	Scanner ADF cover open jam. Possible causes: <ul style="list-style-type: none"> ADF cover sensor flag ADF cover sensor ADF improper grounding of the feed shaft to skew shaft or feed shaft to ADF upper cover. 	<ul style="list-style-type: none"> Remove all media present in the media path. Check ADF left door interlock sensor for proper operation. Go to “292.00—Scanner ADF cover open jam service check” on page 2-98.
293.00	Paper missing.	<ul style="list-style-type: none"> Remove all media present in the media path. Check the ADF input sensor for proper operation. Go to “ADF input sensor service check” on page 2-135.
293.02	Flatbed cover open.	<ul style="list-style-type: none"> Remove all media present in the media path. Check the ADF closed interlock switch for proper operation. Go to “293.02—Flatbed cover open jam service check” on page 2-101.
294.00	Scanner static jam—ADF exit sensor.	<ul style="list-style-type: none"> Remove all media present in the media path. Check the ADF media exit sensor for proper operation. Go to “ADF exit sensor service check” on page 2-134.
294.01	Scanner ADF eject jam.	<ul style="list-style-type: none"> Remove all media present in the media path. Check for obstructions in the media path. Check the sensor (ADF media exit) for proper operation. Go to “ADF exit sensor service check” on page 2-134.

Error code	Description	Action
296	Scanner flatbed CCD carrier module locked in home position.	Unlock the scanner flatbed CCD carrier module lock (scanner lock). 
8xx service error messages		
840.01 Scanner Error	Scanner disabled	Enable the Scanner: <ol style="list-style-type: none"> 1. Enter the Configuration Menu (press and hold 2 and 6, turn on the MFP, and release the buttons when the progress bar displays). 2. Touch Disable Scanner in the Config Menu. 3. Touch the left or right arrows to select Enabled (default), Disabled, or ADF Disabled. 4. Touch Submit. Submitting changes... is displayed.
840.02 Scanner Error	Scanner auto disabled	Print out the error log and see what caused the MFP to disable Go to the Configuration Menu and enable the scanner: <ol style="list-style-type: none"> 1. Enter the Configuration Menu (press and hold 2 and 6, turn on the MFP, and release the buttons when the progress bar displays). 2. Touch Disable Scanner in the Config Menu. 3. Touch the left or right arrows to select Enabled (default), Disabled, or ADF Disabled. 4. Touch Submit. Submitting changes... is displayed.
841.xx Scanner Error	Image pipeline ASIC	Replace MDC card. See “Scanner MDC card removal” on page 4-247.
842.00 Scanner Failure	Communication Failure	Go to “842.xx—Scanner Failure—Communication failure service check” on page 2-101.
843.00 Scanner Failure	Carriage failed to home or move to desired position.	Go to “843.00—Scanner Failure—Carriage failed to move service check” on page 2-102.
843.01 Scanner Failure	ADF mechanical failure	Go to “843.01, 843.02—Scanner Failure service check” on page 2-102.
843.02 Scanner Failure	Mechanical failure detected.	Go to “843.01, 843.02—Scanner Failure service check” on page 2-102.
843.03 Scanner Failure	Pick roller engage failure.	POR the printer, and then an 843.02 error code appears. Go to “843.01, 843.02—Scanner Failure service check” on page 2-102.

Error code	Description	Action
843.04 Scanner Failure	Pic roller disengage failure	POR the printer, and then an 843.02 error code appears. Go to “843.01, 843.02—Scanner Failure service check” on page 2-102.
844.00 Scanner Error	Front scan module output level error.	Go to “844.xx—Scanner Error—scan module output level error service check” on page 2-103.
844.02 Scanner Error	Front scan module lamp level too low.	Go to “844.xx—Scanner Error—scan module output level error service check” on page 2-103.
844.04 Scanner Error	Front scan module has excessive noise.	Go to “844.xx—Scanner Error—scan module output level error service check” on page 2-103.
844.06 Scanner Error	Front scan module has excessive variability.	Go to “844.xx—Scanner Error—scan module output level error service check” on page 2-103.
844.08 Scanner Error	Front scan module banding.	Go to “844.xx—Scanner Error—scan module output level error service check” on page 2-103.
845.00 Scanner Failure	Front scan module cable failure or SCC card failure.	Go to “845.xx—Scanner Failure service check” on page 2-103.
845.02 Scanner Failure	Front scan module cable failure or SCC card failure.	Go to “845.xx—Scanner Failure service check” on page 2-103.
846.00 Scanner Failure	Front calibration strip unusable.	Go to “846.xx—Front calibration strip error service check” on page 2-104.
846.02 Scanner Failure	Front calibration strip too far left.	Go to “846.xx—Front calibration strip error service check” on page 2-104.
846.03 Scanner Failure	Front calibration strip too far right.	Go to “846.xx—Front calibration strip error service check” on page 2-104.
846.04 Scanner Failure	Front calibration strip has excessive skew.	Go to “846.xx—Front calibration strip error service check” on page 2-104.
846.05 Scanner Failure	Front calibration strip has excessive bow.	Go to “846.xx—Front calibration strip error service check” on page 2-104.
848.01 Scanner Failure	Modem configuration ID mismatch. Possible cause is the MFP has a modem installed, but its Configuration ID indicates that a modem should not be present.	Remove the fax modem.
849.01	Hard disk configuration ID mismatch. The possible cause is a hard disk is installed, but the configuration ID does not support it.	Remove the hard disk.
9xx service error messages		
900.00–900.99 Software Error (except 900.05)	Unrecoverable RIP software error.	<ul style="list-style-type: none"> • POR the printer. • If the error message persists, replace the system board. See “System board removal” on page 4-148.
900.05 Software Error.	Transfer module has failed	<ul style="list-style-type: none"> • POR the printer. • If the error message persists, go to “900.05—Transfer module error service check” on page 2-104.

Error code	Description	Action
902.01–902.99 Engine Software Error (except 902.59 and 902.60)	Unrecoverable system software errors.	<ul style="list-style-type: none"> • POR the printer. • If the error message persists, replace the system board. See “System board removal” on page 4-148.
902.59 Error	RIP NVRAM MGR problem.	<ul style="list-style-type: none"> • POR the printer. • If the problem persists, go to “902.59—Engine software error, NVRAM MGR problem” on page 2-105.
902.60 Error	Error communicating with cartridge.	<ul style="list-style-type: none"> • POR the printer. • If the error message persists, check for the correct cartridges. • Replace the cartridges.
903.01–903.15 Engine Software Error	Unrecoverable system software errors.	<ul style="list-style-type: none"> • POR the printer. • If the error message persists, replace the system board. See “System board removal” on page 4-148.
904.01–904.04 Software Error	Unrecoverable system software errors.	<ul style="list-style-type: none"> • POR the printer. • If the error message persists, replace the system board. See “System board removal” on page 4-148.
905.00–905.99 Software Error	Unrecoverable system software errors.	<ul style="list-style-type: none"> • POR the printer. • If the error message persists, replace the system board. See “System board removal” on page 4-148.
910.xx Engine Software Error	RIP software error interface violation	<ul style="list-style-type: none"> • POR the printer. • If the error persists, replace the system board. See “System board removal” on page 4-148.
920.01 POST Error	Aligner motor not connected.	<ul style="list-style-type: none"> • POR the printer. • If the error message persists, go to “147.xx, 920.01—Motor (aligner) error service check” on page 2-55.
920.02 POST Error	Tray 1 motor not connected.	<ul style="list-style-type: none"> • POR the printer. • If the error message persists, go to “140.xx, 920.02—Autocomp (tray 1) motor error service check” on page 2-46.
920.03 POST Error	Transfer module not connected.	<ul style="list-style-type: none"> • POR the printer. • If the error message persists, go to “920.03, 920.25—Transfer Module Missing error service check” on page 2-106.
920.04 POST Error	Fuser motor not connected.	<ul style="list-style-type: none"> • POR the printer. • If the error message persists, go to “920.04—POST error service check” on page 2-107.
920.05 POST Error	Printhead motor not connected.	<ul style="list-style-type: none"> • POR the printer. • If the error message persists, go to “920.05—POST—printhead motor not connected error service check” on page 2-108.
920.06 POST Error	Input sensor not connected.	<ul style="list-style-type: none"> • POR the printer. • If the error message persists, go to “Input sensor service check” on page 2-143.

Error code	Description	Action
920.07 POST Error	Narrow media sensor not connected.	<ul style="list-style-type: none"> • POR the printer. • If the error message persists, go to “920.07—POST error service check” on page 2-109.
920.08 POST Error	Exit sensor not connected.	<ul style="list-style-type: none"> • POR the printer. • If the error message persists, go to “Exit sensor service check” on page 2-141.
920.09 POST Error	Four toner sensors are not connected.	<ul style="list-style-type: none"> • POR the printer. • If the error message persists, go to “920.09—POST—Four toner sensor not connected error service check” on page 2-110.
920.10 POST Error	Three toner sensors are not connected.	<ul style="list-style-type: none"> • POR the printer. • If the error message persists, go to “920.10—POST—Three toner sensors not connected error service check” on page 2-111.
920.11 POST Error	Two toner sensors are not connected.	<ul style="list-style-type: none"> • POR the printer. • If the error message persists, go to “920.11—POST—Two toner sensors not connected error service check” on page 2-112.
920.12 POST Error	One toner sensor is not connected.	<ul style="list-style-type: none"> • POR the printer. • If the error message persists, go to “920.12—POST—One sensor not connected error service check” on page 2-113.
920.13 POST Error	Cartridge motor 1 (top) not connected.	<ul style="list-style-type: none"> • POR the printer. • If the error message persists, go to “920.13—POST error service check” on page 2-113.
920.14 POST Error	Cartridge motor 2 (middle) is not connected.	<ul style="list-style-type: none"> • POR the printer. • If the error message persists, go to “920.14—POST—Cartridge motor 2 not connected error service check” on page 2-115.
920.15 POST Error	Bad transfer module NVRAM data.	<ul style="list-style-type: none"> • POR the printer. • If the error message persists, go to “920.15, 920.20—POST—Bad transfer module NVRAM data error service check” on page 2-116.
920.16 POST Error	Bad printhead NVRAM data.	<ul style="list-style-type: none"> • POR the printer. • If the error message persists, go to “920.16—POST error service check” on page 2-117.
920.17 POST Error	Output bin cable not connected.	<ul style="list-style-type: none"> • POR the printer. • If the error message persists, go to “920.17—POST error service check” on page 2-118.
920.18 POST Error	Cartridge motor 3 (bottom) is not connected.	<ul style="list-style-type: none"> • POR the printer. • If the error message persists, go to “920.18—POST—Cartridge motor 3 not connected error service check” on page 2-119.
920.19 POST Error	Stepper motor not connected.	<ul style="list-style-type: none"> • POR the printer. • If the error message persists, go to “920.19—POST—Transfer module stepper motor not connected error service check” on page 2-120.

Error code	Description	Action
920.20 POST Error	Incompatible transfer module.	<ul style="list-style-type: none"> • POR the printer. • If the error message persists, go to “920.15, 920.20—POST—Bad transfer module NVRAM data error service check” on page 2-116.
920.21 POST Error	+24 V power supply failure.	<ul style="list-style-type: none"> • POR the printer. • If the error message persists, replace the low-voltage power supply. See “Low-voltage power supply (LVPS) removal” on page 4-104.
920.22 POST Error	Fuser bubble sensor is not connected.	If the error message persists, go to “Bubble sensor service check” on page 2-138.
920.23 POST Error	Duplex motor is not connected.	<ul style="list-style-type: none"> • POR the printer. • If the error message persists, go to “920.23—POST error service check” on page 2-124.
920.25 POST Error	Bad temperature and humidity sensor.	<ul style="list-style-type: none"> • POR the printer. • If the problem persists, go to “920.03, 920.25—Transfer Module Missing error service check” on page 2-106.
920.26 POST Error	Top access cover sensor not connected.	Go to “920.26—POST service check” on page 2-125.
920.27 POST Error	Option board ID unknown.	Go to “920.27, 920.28, 920.29—POST (power on self test) service check” on page 2-126.
920.28 POST Error	Option type unknown.	Go to “920.27, 920.28, 920.29—POST (power on self test) service check” on page 2-126.
920.29 POST Error	Option product ID unknown.	Go to “920.27, 920.28, 920.29—POST (power on self test) service check” on page 2-126.
920.30 POST Error	Option sensor disconnected.	Use the following list to determine which service check to use: <ul style="list-style-type: none"> • Tray 2—Go to “242.02—Paper Jam error service check” on page 2-73. • Tray 3—Go to “243.02—Paper Jam service check” on page 2-79. • Tray 4—Go to “244.02—Paper Jam service check” on page 2-86. • Tray 5—Go to “245.02—Paper Jam service check” on page 2-92.
920.31 POST Error	Option hardware error (generic)	Contact your next level of support.
925.01 Fan Error	Fan has stalled.	<ul style="list-style-type: none"> • POR the printer. • If the error message persists, go to “925.01, 925.03, 925.05—Fan error service check” on page 2-126.
925.02 Blower Error	Blower has stalled.	<ul style="list-style-type: none"> • POR the printer. • If the error message persists, go to “925.02, 925.04, 925.06—Blower error service check” on page 2-127.
925.03 Fan Error	Fan has stalled.	<ul style="list-style-type: none"> • POR the printer. • If the error message persists, go to “925.01, 925.03, 925.05—Fan error service check” on page 2-126.

Error code	Description	Action
925.04 Blower Error	Blower has stalled.	<ul style="list-style-type: none"> • POR the printer. • If the error message persists, go to “925.02, 925.04, 925.06—Blower error service check” on page 2-127.
925.05 Fan Error	Fan has stalled.	<ul style="list-style-type: none"> • POR the printer. • If the error message persists, go to “925.01, 925.03, 925.05—Fan error service check” on page 2-126.
925.06 Blower Error	Blower has stalled.	<ul style="list-style-type: none"> • POR the printer. • If the error message persists, go to “925.02, 925.04, 925.06—Blower error service check” on page 2-127.
945.01 Transfer Roll	Yellow transfer roll has failed.	<ul style="list-style-type: none"> • POR the printer. • If the error message persists, go to “945.xx, 947.xx—Transfer roll error service check” on page 2-128.
945.02 Transfer Roll	Cyan transfer roll has failed.	<ul style="list-style-type: none"> • POR the printer. • If the error message persists, go to “945.xx, 947.xx—Transfer roll error service check” on page 2-128.
945.03 Transfer Roll	Magenta transfer roll has failed.	<ul style="list-style-type: none"> • POR the printer. • If the error message persists, go to “945.xx, 947.xx—Transfer roll error service check” on page 2-128.
945.04 Transfer Roll	Black transfer roll has failed.	<ul style="list-style-type: none"> • POR the printer. • If the error message persists, go to “945.xx, 947.xx—Transfer roll error service check” on page 2-128.
947.01 Transfer Roll	Yellow transfer roll has failed.	<ul style="list-style-type: none"> • POR the printer. • If the error message persists, go to “945.xx, 947.xx—Transfer roll error service check” on page 2-128.
947.02 Transfer Roll	Cyan transfer roll has failed.	<ul style="list-style-type: none"> • POR the printer. • If the error message persists, go to “945.xx, 947.xx—Transfer roll error service check” on page 2-128.
947.03 Transfer Roll	Magenta transfer roll has failed.	<ul style="list-style-type: none"> • POR the printer. • If the error message persists, go to “945.xx, 947.xx—Transfer roll error service check” on page 2-128.
947.04 Transfer Roll	Black transfer roll has failed.	<ul style="list-style-type: none"> • POR the printer. • If the error message persists, go to “945.xx, 947.xx—Transfer roll error service check” on page 2-128.
950.00–950.29 NVRAM Failure	Mismatch between operator panel assembly NVRAM and system board.	<ul style="list-style-type: none"> • POR the printer. • If the error message persists, go to “950.00–950.29—EPROM mismatch failure” on page 2-130.
951.01–951.99	System board NVRAM failure.	<ul style="list-style-type: none"> • POR the printer. • If the error message persists, replace the system board. See “System board removal” on page 4-148.

Error code	Description	Action
952.01–952.99 NVRAM Error	CRC error has occurred. This is recoverable.	Perform a POR to clear the error.
953.01–953.99 NVRAM Failure	Operator panel assembly NVRAM failure.	<ul style="list-style-type: none"> • POR the printer. • Replace the operator panel assembly if the error message persists. See “Operator panel assembly removal” on page 4-26.
954.01–954.99 NVRAM Failure	System NVRAM failure.	<ul style="list-style-type: none"> • POR the printer. • If the error message persists, replace the printhead. See “Printhead removal, installation, and adjustment” on page 4-128.
955.01–955.99 Code Failure	System board memory failure.	<ul style="list-style-type: none"> • POR the printer. • If the error message persists, replace the system board. See “System board removal” on page 4-148.
956.01–956.99 System Card Failure	Processor failure.	<ul style="list-style-type: none"> • POR the printer. • If the error message persists, go to “956.xx—System board failure service check” on page 2-131.
957.00–857.99 System Failure	ASIC failure.	<ul style="list-style-type: none"> • POR the printer. • If the error message persists, replace the system board. See “System board removal” on page 4-148.
958.01–958.99 Memory Failure	Processor failure.	<ul style="list-style-type: none"> • POR the printer. • If the error message persists, replace the system board. See “System board removal” on page 4-148.
959.00–959.05 Engine Code Error	Invalid engine code	<ul style="list-style-type: none"> • POR the printer. • If the error message persists, download the engine code again. • POR the printer again. • If the error message persists, replace the system board. See “System board removal” on page 4-148.
959.20–959.28 System Failure	System board failure.	<ul style="list-style-type: none"> • POR the printer. • If the error message persists, replace the system board. See “System board removal” on page 4-148.
960.01—960.99 Memory Error	Memory failure.	<ul style="list-style-type: none"> • POR the printer. • If the error message persists, replace the system board. See “System board removal” on page 4-148.
961.01–961.99 Memory Failure	Memory failure.	<ul style="list-style-type: none"> • POR the printer. • If the error message persists, replace the system board. See “System board removal” on page 4-148.
962.00–962.99 Memory Failure	Memory failure.	<ul style="list-style-type: none"> • POR the printer. • If the error message persists, replace the system board. See “System board removal” on page 4-148.

Error code	Description	Action
963.00–963.99 Memory Failure	Memory failure.	<ul style="list-style-type: none"> • POR the printer. • If the error message persists, replace the system board. See “System board removal” on page 4-148.
964.00–964.88 Emulation Error	Download emulation CRC error.	<ul style="list-style-type: none"> • POR the printer. • If the error message persists, download code a second time.
975.00–975.99 Network Error	Unrecognized network port.	Contact your next level of support.
976.00–976.99 Network Error	Unrecoverable software error in network port.	Contact your next level of support.
978.00–978.99 Network Error	Bad checksum while programming network port	Contact your next level of support.
979.00–979.99 Network Error	Flash parts failed while programming network port.	Contact your next level of support.
980.00–980.99 <device> Communications Error	Unreliable communications with specified device.	<ul style="list-style-type: none"> • POR the printer. • If the error message persists, replace the system board. See “System board removal” on page 4-148.
981.00–981.99 <device> Communications Error	Protocol violation by specified device.	<ul style="list-style-type: none"> • POR the printer. • If the error persists, replace the system board. See “System board removal” on page 4-148.
982.00–982.12 <device> Communications Error	Communications error by specified device.	<ol style="list-style-type: none"> 1. Turn the power off. 2. Remove, and reinstall the output option. 3. Turn the main power back on. 4. Check all output option interface connections if the problem remains.
983.00–983.99 <device> Communications Error	Invalid command parameter by specified device.	<ul style="list-style-type: none"> • POR the printer. • If the error message persists, replace the system board. See “System board removal” on page 4-148.
984.00–984.99 <device> Communications Error	Invalid command parameter by specified device.	<ul style="list-style-type: none"> • POR the printer. • If the error message persists, replace the system board. See “System board removal” on page 4-148.
990.00–990.29 Option Error	Output error	Contact your next level of support.
991.00–991.29 <device> Error	Specified device has detected an error.	<ul style="list-style-type: none"> • POR the printer. • If the error message persists, replace the system board. See “System board removal” on page 4-148.

Service checks

110.xx—Mirror motor service check

	<p>CAUTION—POTENTIAL EYE INJURY:</p> <p>Laser Radiation—Avoid eye exposure to the beam. Always point the printhead laser down into the packaging as shown. The laser can cause damage to your eyesight or the eyesight of others.</p>
---	---

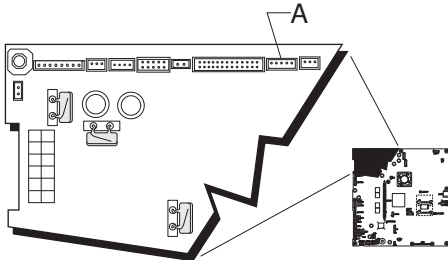
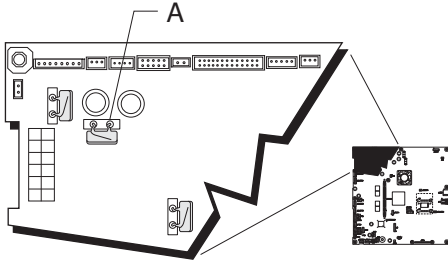

Step	Questions / actions	Yes	No
1	<p>View the Event Log:</p> <ol style="list-style-type: none"> 1. Enter Diagnostics mode (press and hold 3 and 6, turn on the MFP, and release the buttons when the progress bar displays). 2. Touch EVENT LOG from Diag Menu. 3. Touch Display Log. <p>Has an 110.xx error occurred three times or more?</p>	<p>Replace the printhead. See “Printhead removal, installation, and adjustment” on page 4-128.</p>	Go to step 2.
2	<p>Turn the printer off, and then remove the rear frame cover. See “Rear frame cover removal” on page 4-38. Check the cable in connector JMIRR1 for proper connection to the system board, the printhead cable for pinch points, and the cable or connector for any other damage.</p>  <p>Is the cable damaged?</p>	<p>Replace the printhead. See “Printhead removal, installation, and adjustment” on page 4-128.</p>	Go to step 3.
3	 <p>Is the fuse blown?</p>	<p>Replace the system board. See “System board removal” on page 4-148.</p>	Go to step 4.

Step	Questions / actions	Yes	No
4 	<p>Perform the printhead verification to check whether the new printhead will solve the problem. See “Printhead verification” on page 3-52.</p> <p>Perform the Mirror Motor Test. Bring the printer up in the Diagnostics menu (turn off the printer, press and hold 3 and 6, turn on the printer.) See “Mirror Motor Test” on page 3-22.</p> <p>Did the Mirror Motor pass the test?</p>	Replace the printhead. See “Printhead removal, installation, and adjustment” on page 4-128.	Replace the system board. See “System board removal” on page 4-148.

111.xx, 112.xx, 113.xx, and 114.xx—Printhead error service check

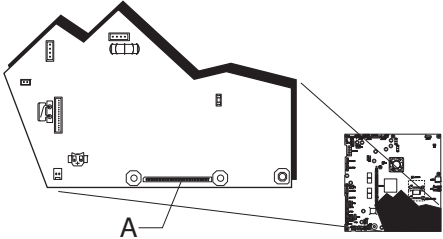
	<p>CAUTION—POTENTIAL EYE INJURY:</p> <p>Laser Radiation—Avoid eye exposure to the beam. Always point the printhead laser down into the packaging as shown. The laser can cause damage to your eyesight or the eyesight of others.</p>
---	---

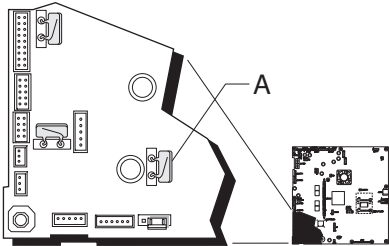
Step	Questions / actions	Yes	No
1	<p>View the Event Log:</p> <ol style="list-style-type: none"> Enter Diagnostics mode (press and hold 3 and 6, turn on the MFP, and release the buttons when the progress bar displays). Touch EVENT LOG from Diag Menu. Touch Display Log. <p>Has an 110.xx error occurred three times or more?</p>	Replace the printhead. See “Printhead removal, installation, and adjustment” on page 4-128.	Go to step 2.
2	<p>Turn the printer off, and then remove the rear frame cover. See “Rear frame cover removal” on page 4-38. Check the cable in connector JPH1 (A)(5 V interlock switch cable) for proper connection to the system board, the cable for pinch points, and the cable or connector for any other damage.</p>  <p>Is the cable damaged?</p>	Replace the 5 V interlock switch. See “5 V interlock switch cable removal” on page 4-48.	Go to step 3.



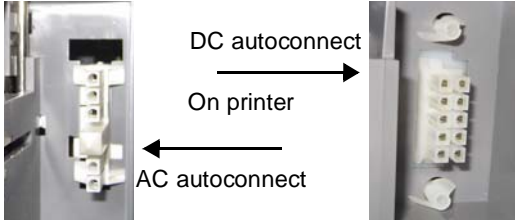
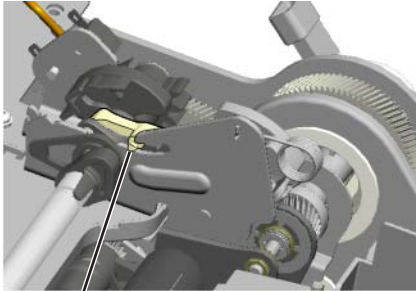

Step	Questions / actions	Yes	No
3	<p>Measure the resistance across fuse F13 (A) on the system board.</p>  <p>Is the fuse blown?</p>	<p>Replace the system board. See “System board removal” on page 4-148.</p>	<p>Go to step 4.</p>
4	 <p>Perform the printhead verification to check whether the new printhead solves the problem. See “Printhead verification” on page 3-52.</p> <p>Perform the Servo Laser Test. See “Servo Laser Test” on page 3-22.</p> <p>Did the printhead motor pass the test?</p>	<p>Replace the printhead. See “Printhead removal, installation, and adjustment” on page 4-128.</p>	<p>Replace the system board. See “System board removal” on page 4-148.</p>

120.xx—Fuser error service check

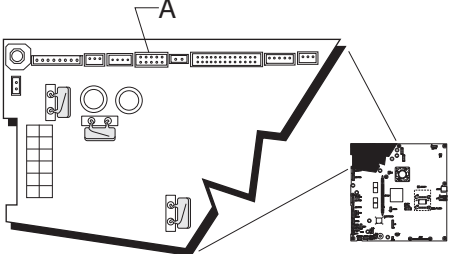
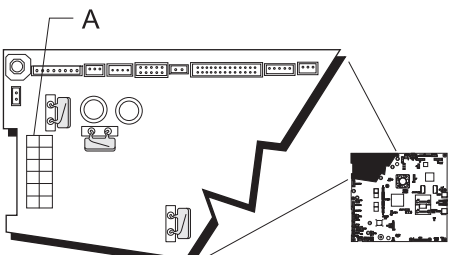
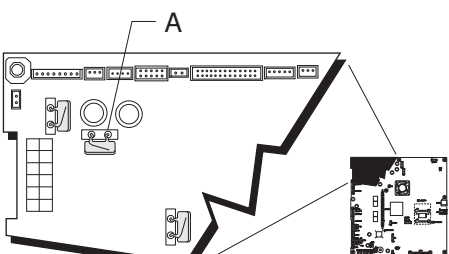
Step	Questions / actions	Yes	No
1	<p>Check the input voltage switch on the back of the low-voltage power supply (LVPS).</p> <p>Note: Some LVPS FRUs do not have a switch, and are switch automatically. If your FRU does not have this switch, go to step 2.</p>  <p>Is the voltage level (115 V/230 V) properly set?</p>	<p>Go to step 2.</p>	<p>Set the switch for the proper country voltage.</p>

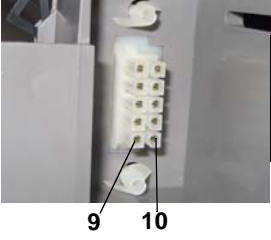
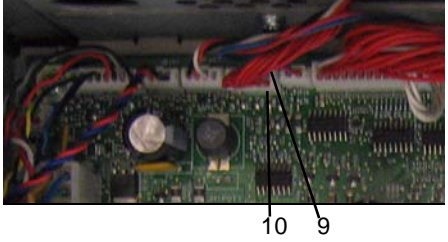
Step	Questions / actions	Yes	No
2	<p>1. Remove the fuser. See “Fuser assembly removal” on page 4-94.</p> <p>2. Check the AC and DC autoconnects on both the fuser and the MFP for damage.</p> <p>Fuser autoconnects</p>   <p>Are the connectors damaged?</p>	<p>Replace the appropriate cable (either the fuser AC or the fuser DC cable). See “Fuser AC cable removal” on page 4-95 or “Fuser DC cable removal” on page 4-97.</p>	<p>Go to step 3</p>
3	<p>Replace the fuser. See “Fuser assembly removal” on page 4-94.</p> <p>Does the error clear?</p>	<p>Problem resolved.</p>	<p>Go to step 4.</p>
4	<p>Turn the printer off, and then remove the fuser. Check the camshaft follower on the right side. If the camshaft follower (A) is above the crescent-shaped groove, it needs to be pressed down into the proper location.</p>  <p>Is the camshaft follower on the right side properly placed in the groove?</p>	<p>Go to step 5.</p>	<p>Press the camshaft follower into the groove.</p>

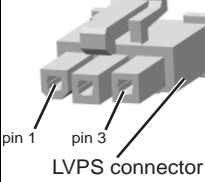
Step	Questions / actions	Yes	No
<p>5</p>	<p>Remove the rear frame cover. See “Rear frame cover removal” on page 4-38. Check the cable in connector JFUSER1 (fuser DC cable) for proper connection to the system board, the cable for pinch points, and the cable or connector for any other damage.</p>  <p>Is the cable damaged?</p>	<p>Replace the fuser DC cable. See “Fuser DC cable removal” on page 4-97.</p>	<p>Go to step 6.</p>
<p>6</p>	<p>Check the cable in connector JLVPS2 for proper connection to the system board, the cable for pinch points, and the cable or connector for any other damage.</p>  <p>Is the cable damaged?</p>	<p>Replace the LVPS. See “Low-voltage power supply (LVPS) removal” on page 4-104.</p>	<p>Go to step 7.</p>
<p>7</p>	<p>Measure the resistance across fuse F6 on the system board.</p>  <p>Is the fuse blown?</p>	<p>Replace the system board. See “System board removal” on page 4-148.</p>	<p>Go to step 8.</p>

Step	Questions / actions	Yes	No						
<p>8</p>	<p>Check for the following continuity between the DC autoconnect and JFUSER1 on the system board.</p>  <table border="1" data-bbox="568 373 799 499"> <thead> <tr> <th>DC auto-connect</th> <th>JFUSER1</th> </tr> </thead> <tbody> <tr> <td>Pin 9</td> <td>Pin 9</td> </tr> <tr> <td>Pin 10</td> <td>Pin 10</td> </tr> </tbody> </table>  <p>Is continuity present?</p>	DC auto-connect	JFUSER1	Pin 9	Pin 9	Pin 10	Pin 10	<p>Go to step 9.</p>	<p>Replace the fuser DC cable. See “Fuser DC cable removal” on page 4-97.</p>
DC auto-connect	JFUSER1								
Pin 9	Pin 9								
Pin 10	Pin 10								
<p>9</p> 	<p>Check for continuity between the following pins of the AC autoconnect and the pins of the connector that connects to the LVPS.</p>  <table border="1" data-bbox="503 976 711 1102"> <thead> <tr> <th>LVPS connect</th> <th>AC Auto-connect</th> </tr> </thead> <tbody> <tr> <td>Pin 1</td> <td>Pin 5</td> </tr> <tr> <td>Pin 3</td> <td>Pin 1</td> </tr> </tbody> </table>  <p>Is continuity present?</p>	LVPS connect	AC Auto-connect	Pin 1	Pin 5	Pin 3	Pin 1	<p>Replace the system board. See “System board removal” on page 4-148.</p>	<p>Replace the fuser AC cable. See “Fuser AC cable removal” on page 4-95.</p>
LVPS connect	AC Auto-connect								
Pin 1	Pin 5								
Pin 3	Pin 1								

140.xx, 920.02—Autocomp (tray 1) motor error service check

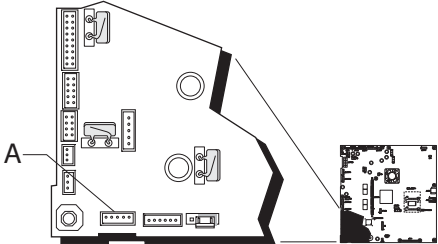
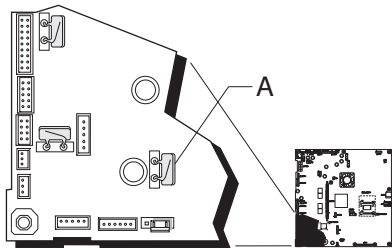
Step	Questions / actions	Yes	No
1	1. Turn the printer off. 2. Remove the rear frame cover. See “Rear frame cover removal” on page 4-38. 3. Check the cable in connector JFDPCK1 for proper connection to the system board, the cable for pinch points, and the cable or connector for any other damage.  Is the cable damaged?	Replace the paper pick mechanism. See “Paper pick mechanism assembly removal” on page 4-117.	Go to step 2.
2	Measure the resistance across fuse F13 on the system board.  Is the fuse blown?	Replace the system board. See “System board removal” on page 4-148.	Go to step 3.
3	1. Disconnect the cable in connector JFDPCK1, and then connect the cable for the new paper pick mechanism. 2. Bring the printer up in Diagnostics Menu (turn the multifunction printer off, press and hold 3 and 6 , turn the MFP on, and then release the buttons when the progress bar displays). 3. Touch Print Test . 4. Touch Tray 1 . 5. Touch Single . Did the new pick motor turn before the feed error occurred?	Replace the paper pick mechanism. See “Paper pick mechanism assembly removal” on page 4-117.	Replace the system board. See “System board removal” on page 4-148.

142.xx, 906.01–906.04—Motor (fuser) error service check

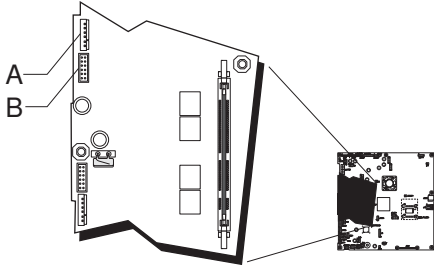
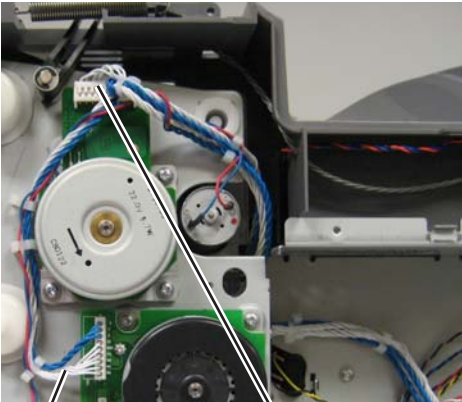
Step	Questions / actions	Yes	No
1	<p>Turn the printer off, and then remove the rear frame cover. See “Rear frame cover removal” on page 4-38. Check the cables in connectors JCARTP1 (A) and JCARTS1 (B) (cartridge motor 1/fuser motor cable) for proper connection to the system board, for cable pinch points, and for any other damage to the cable or connectors.</p>  <p>Is either cable damaged?</p>	<p>Replace the cartridge motor1/fuser motor cable. See “Cartridge motor 1/ fuser cable removal” on page 4-55.</p>	<p>Go to step 2.</p>
2	<p>Remove the right cover. See “Right cover removal” on page 4-39. Check the cartridge motor 1/fuser motor cable for proper connection to the EP drive assembly, for pinch points for the cable, and for cable or connector damage.</p>  <p>Is either cable damaged?</p>	<p>Replace the cartridge motor 1/fuser motor cable. See “Cartridge motor 1/ fuser cable removal” on page 4-55.</p>	<p>Go to step 3.</p>

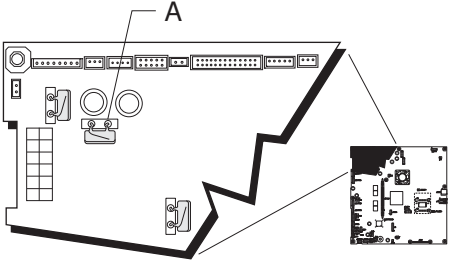
Step	Questions / actions	Yes	No
3	<p>Measure the resistance across fuse F6 on the system board.</p>  <p>Is the fuser blown?</p>	<p>Replace the system board. See “System board removal” on page 4-148.</p>	<p>Replace the EP drive assembly. See “Electrophotographic (EP) drive assembly removal” on page 4-70.</p>

143.xx—Motor (EP drive assembly top cartridge) error service check

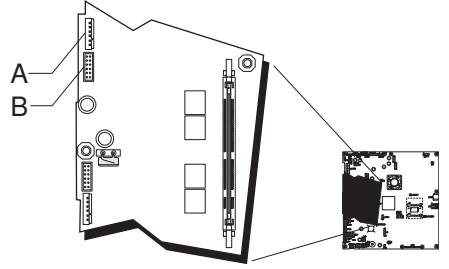
Step	Questions / actions	Yes	No
1	<ol style="list-style-type: none"> 1. Turn the printer off. 2. Remove the rear frame cover. See “Rear frame cover removal” on page 4-38. 3. Remove the right cover. See “Right cover removal” on page 4-39. 4. Check the cables in connectors JCARTP1 (A) and JCARTS1 (B) (cartridge motor 1/fuser motor cable) for proper connection to the system board, for the cable for pinch points, and for the cable or connector for any other damage.  <p>Is the cable damaged?</p>	<p>Replace the cartridge motor 1/fuser cable. See “Cartridge motor 1/fuser cable removal” on page 4-55.</p>	<p>Go to step 2.</p>

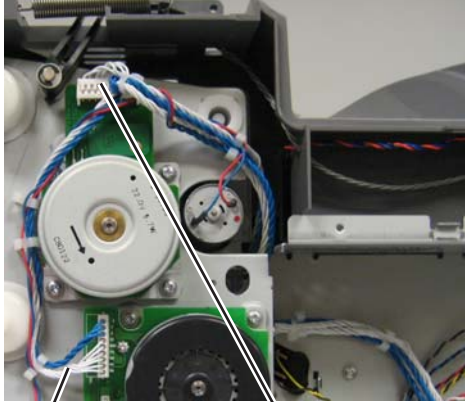
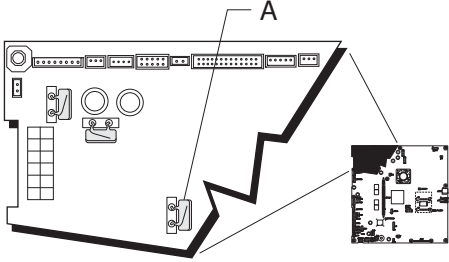
Step	Questions / actions	Yes	No
2	<p>Remove the right cover. See “Right cover removal” on page 4-39. Check the cartridge motor 1/fuser motor cable for proper connection to the EP drive assembly, for pinch points for the cable, or damage to the cable or connector.</p>  <p>Is either cable damaged?</p>	<p>Replace the cartridge motor 1/fuser motor cable. See “Cartridge motor 1/ fuser cable removal” on page 4-55</p>	<p>Go to step 3.</p>
3	<p>Measure the resistance across fuse F7 on the system board.</p>  <p>Is the fuse blown?</p>	<p>Replace the system board. See “System board removal” on page 4-148.</p>	<p>Replace the EP drive assembly. See “Electrophotographic (EP) drive assembly removal” on page 4-70.</p>

144.xx—Motor (EP drive assembly middle cartridge) error service check

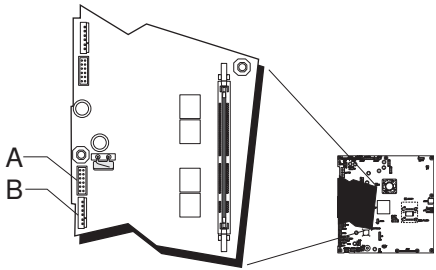
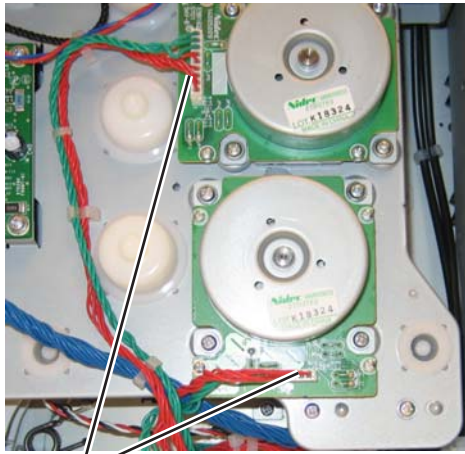
Step	Questions / actions	Yes	No
<p>1</p>	<p>1. Turn the printer off. 2. Remove the rear frame cover. See “Rear frame cover removal” on page 4-38. 3. Remove the right cover. See “Right cover removal” on page 4-39. 4. Check the cables in connector JCARTP2 and JCARTS2 (cartridge motor 2/3 cable) for proper connection to the system board, for cable pinch points, and for any other damage to the cable or connector.</p>  <p>Is the cable damaged?</p>	<p>Replace cartridge motor 2/3 cable. See “Cartridge motor 2/3 cable removal” on page 4-57.</p>	<p>Go to step 2.</p>
<p>2</p>	<p>Remove the right cover. See “Right cover removal” on page 4-39. Check the cartridge motor 2/3 cable for proper connection to the EP drive assembly, pinch points for the cable, or damage to the cable or connector (A).</p>  <p>Is either cable damaged?</p>	<p>Replace the cartridge motor 2/3 cable. See “Cartridge motor 2/3 cable removal” on page 4-57.</p>	<p>Go to step 3.</p>

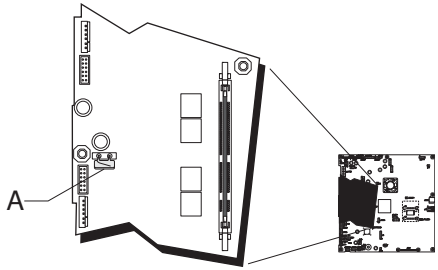

Step	Questions / actions	Yes	No
3	<p>Measure the resistance across fuse F9 on the system board.</p>  <p>Is the fuse blown?</p>	<p>Replace the system board. See “System board removal” on page 4-148.</p>	<p>Replace the EP drive assembly. See “Electrophotographic (EP) drive assembly removal” on page 4-70..</p>

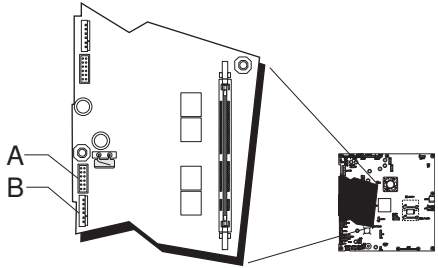

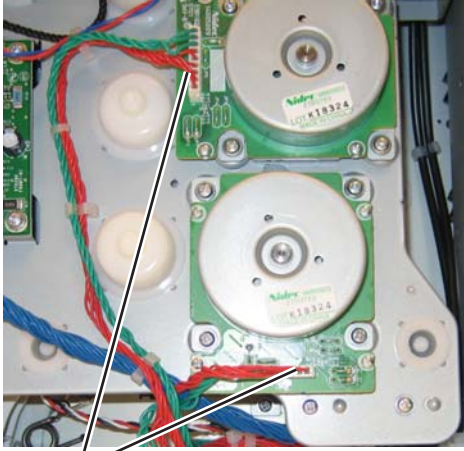
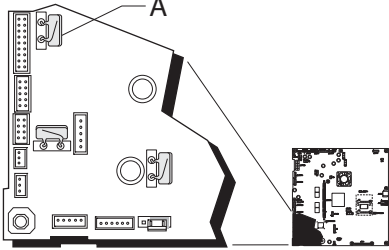
145.xx—Motor (EP drive assembly bottom cartridge) error service check

Step	Questions / actions	Yes	No
1	<ol style="list-style-type: none"> 1. Turn the printer off. 2. Remove the rear frame cover. See “Rear frame cover removal” on page 4-38. 3. Remove the right cover. See “Right cover removal” on page 4-39 4. Check the entire length of the cables in connector JCARTS2 (A) and JCARTP2 (B) (cartridge motor 2/3 cable) for proper connection to the system board, for cable pinch points, and for any other damage to the cable or connector.  <p>Is the cable damaged?</p>	<p>Replace cartridge motor 2/3 cable. See “Cartridge motor 2/3 cable removal” on page 4-57.</p>	<p>Go to step 2.</p>

Step	Questions / actions	Yes	No
2	<p>Check the cartridge motor 2/3 cable for proper connection to the EP drive assembly, pinch points for the cable, and damage to the cable or connector (A).</p>  <p>A</p> <p>Is either cable damaged?</p>	<p>Replace the cartridge motor 2/3 cable. See “Cartridge motor 2/3 cable removal” on page 4-57.</p>	<p>Go to step 3.</p>
3	<p>Measure the resistance across fuse F10 on the system board.</p>  <p>A</p> <p>Is the fuse blown?</p>	<p>Replace the system board. See “System board removal” on page 4-148.</p>	<p>Replace the EP drive assembly. See “Electrophotographic (EP) drive assembly removal” on page 4-70.</p>

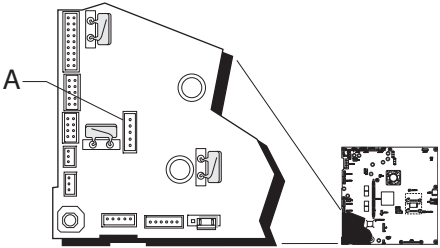
146.xx, 148.xx—Motor (MPF/duplex) error service check

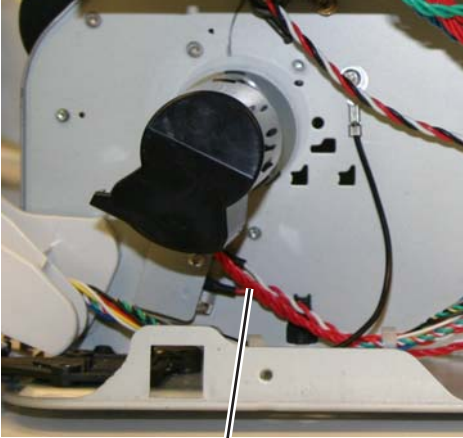

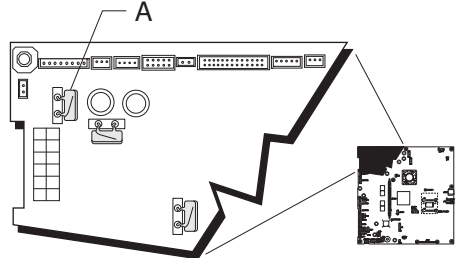
Step	Questions / actions	Yes	No
1	<p>Remove the front access cover assembly. See “Front access cover assembly removal.”</p>  <p>Is the front door assembly damaged?</p>	<p>Replace the front door assembly. See “Front door assembly removal” on page 4-83.</p>	<p>Go to step 2.</p>
2	<p>Is the multipurpose feeder damaged?</p> 	<p>Replace input tray.</p>	<p>Go to step 3.</p>
3	<p>Turn the printer off, and then remove the rear frame cover. See “Rear frame cover removal” on page 4-38. Check the cable in connector JDY1 (MP feeder/duplex motor cable) for proper connection to the system board, the cable for pinch points, and the cable or connector for any other damage.</p>  <p>Is the cable damaged?</p>	<p>Replace the MPF/duplex motor cable. See “Multipurpose feeder (MPF)/duplex motor cable removal” on page 4-114.</p>	<p>Go to step 4.</p>

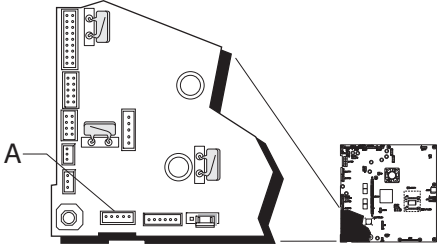

Step	Questions / actions	Yes	No
4	<p>Remove the right cover. See “Right cover removal” on page 4-39. Check the MP feeder/duplex motor cable for proper connection to the MPF/duplex motor, pinch points for the cable, and damage to the cable or connector.</p>  <p style="text-align: center;">A</p> <p>Is either cable damaged?</p>	<p>Replace the MPF/duplex motor cable. See “Multipurpose feeder (MPF)/duplex motor cable removal” on page 4-114.</p>	<p>Go to step 5.</p>
5	<p>Check the MPF/duplex gear assembly for damage.</p>  <p>Do the gears turn freely, and are they free of damage?</p>	<p>Go to step 6.</p>	<p>Replace the MPF/duplex gear assembly. See “Multipurpose feeder (MPF)/duplex gear and housing removal” on page 4-108.</p>
6	<p>Measure the resistance across fuse F5 (A) on the system board.</p>  <p>Is the fuse blown?</p>	<p>Replace the system board. See “System board removal” on page 4-148.</p>	<p>Replace the MPF/duplex gear assembly. See “Multipurpose feeder (MPF)/duplex gear and housing removal” on page 4-108.</p>

147.xx, 920.01—Motor (aligner) error service check

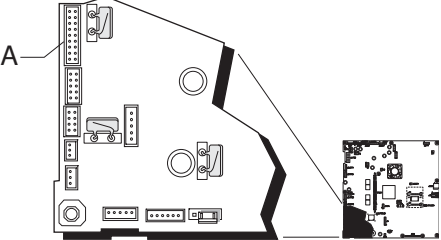
Step	Questions / actions	Yes	No
1	<ol style="list-style-type: none"> 1. Turn the printer off. 2. Remove the rear frame cover. See “Rear frame cover removal” on page 4-38. 3. Remove the right cover. See “Right cover removal” on page 4-39. 4. Check the entire length of the cable in connector JFDPCK1 for proper connection to the system board, for cable pinch points, and for any other damage to the cable or connector.  <p>Is the cable damaged?</p>	<p>Replace the paper pick mechanism. See “Paper pick mechanism assembly removal” on page 4-117.</p>	<p>Go to step 2.</p>
2	<p>Check the cable in connector JFDPCK1 for pinch points, and the cable or connector for any other damage.</p> <p>Is the cable damaged?</p>	<p>Replace the paper pick mechanism. See “Paper pick mechanism assembly removal” on page 4-117.</p>	<p>Go to step 3.</p>
3	<ol style="list-style-type: none"> 1. Disconnect the cable in connector JFDPCK1 on the system board, and then plug in the cable for the new paper pick mechanism. 2. Bring the printer up in Diagnostics Menu (turn the multifunction printer off, press and hold 3 and 6, turn the MFP on, and then release the buttons when the progress bar displays). 3. Touch Motor Test. 4. Touch Align Motor. <p>Can you hear the aligner motor run?</p>	<p>Replace the paper pick mechanism. See “Paper pick mechanism assembly removal” on page 4-117.</p>	<p>Replace the system board. See “System board removal” on page 4-148.</p>

155.xx—Cam motor error service check

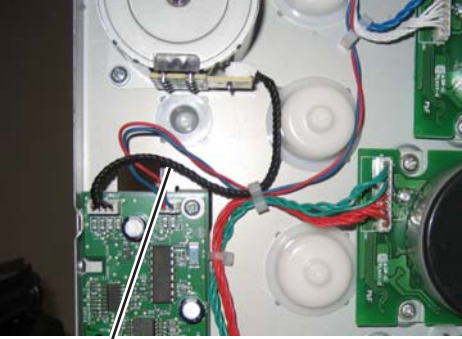
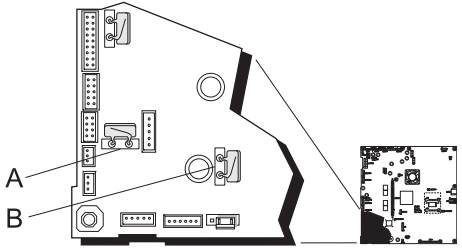
Step	Questions / actions	Yes	No
1	<p>Turn the printer off, and then remove the rear frame cover. See “Rear frame cover removal” on page 4-38. Check the motor driver cable in connector JDVR1 on the system board for proper connection, for cable pinch points, and for any other damage to the cable or connector.</p>  <p>Is the cable damaged?</p>	<p>Replace the motor driver cable. See “Motor driver cable removal” on page 4-106.</p>	<p>Go to step 2.</p>
2	<p>Remove the right cover. See “Right cover removal” on page 4-39. Check the motor driver cable in connector JDVR1 on the system board for proper connection, for cable pinch points, and for any other damages to the cable or connector.</p>  <p>Is the cable damaged?</p>	<p>Replace the motor driver cable. See “Motor driver cable removal” on page 4-106.</p>	<p>Go to step 3.</p>

Step	Questions / actions	Yes	No
3	<p>Check the transport motor cable (A) from the cam motor to the motor driver card (B) for poor connections or damage.</p>  <p>A</p> <p>Is the cable damaged?</p>	<p>Replace the transport motor cable. See “Transport cable removal” on page 4-170.</p>	<p>Go to step 4.</p>
4	<p>Measure the resistance across fuses F12 (A) and F13 (B) on the system board.</p>  <p>A</p> <p>B</p> <p>Is either fuse blown?</p>	<p>Replace the system board. See “System board removal” on page 4-148.</p>	<p>Go to step 5.</p>
5	<p>Visually inspect the motor driver card.</p>  <p>Is the motor driver card damaged?</p>	<p>Replace the motor driver card. See “Motor driver card removal” on page 4-107.</p>	<p>Replace the EP drive assembly. See “Electrophotographic (EP) drive assembly removal” on page 4-70.</p>

156.xx—COD (Color On Demand) motor error service check

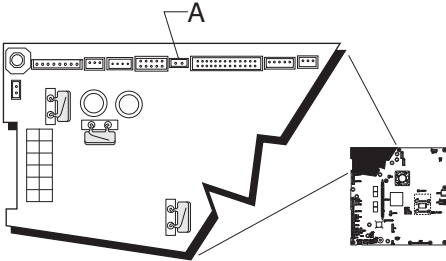
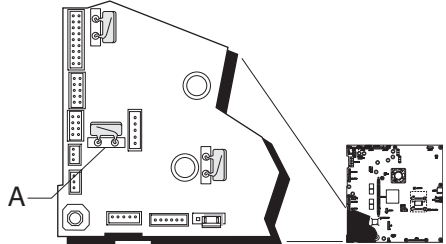
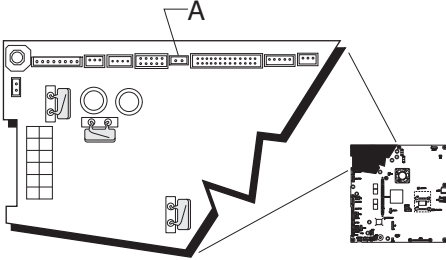
Step	Questions / actions	Yes	No
1	<p>Turn the printer off, and then remove the rear frame cover. See “Rear frame cover removal” on page 4-38. Check the cable in connector JBOR1 on the system board for proper connection, for cable pinch points, and for any other damage to the cable or connector.</p>  <p>Is the cable damaged?</p>	<p>Replace the COD assembly. See “Color on demand assembly removal” on page 4-59.</p>	<p>Go to step 2.</p>
2	<p>Measure the resistance across fuse F12 (A) on the system board.</p>  <p>Is the fuse blown?</p>	<p>Replace the system board. See “System board removal” on page 4-148.</p>	<p>Go to step 3.</p>
3	<p>1. Disconnect the cable in connector JBOR1, and then connect the cable from the new COD group assembly.</p>  <p>2. Bring the printer up in Diagnostics Menu (turn the multifunction printer off, press and hold 3 and 6, turn the MFP on, and then release the buttons when the progress bar displays).</p> <p>3. Touch MOTOR TESTS.</p> <p>4. Touch COD.</p> <p>5. Touch Forward or Reverse.</p> <p>See “Motor tests” on page 3-12.</p> <p>Did the COD motor pass the test?</p>	<p>Replace the COD assembly. See “Color on demand assembly removal” on page 4-59.</p>	<p>Replace the system board. See “System board removal” on page 4-148.</p>

160.xx, 161.xx—Motor Error (option tray 2) service check

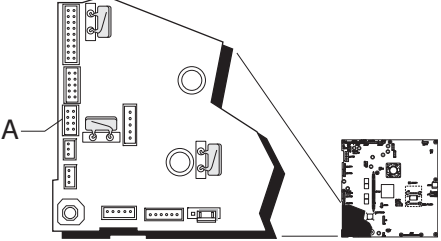
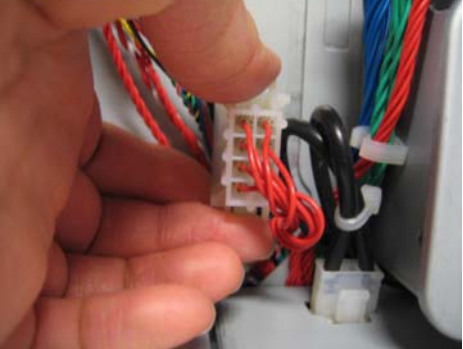
Step	Questions / actions	Yes	No
1	1. Turn the printer off. 2. Reseat option tray 2. 3. Bring the printer up in Diagnostics Menu (turn the multifunction printer off, press and hold 3 and 6 , turn the MFP on, and then release the buttons when the progress bar displays). 4. Touch PRINT TESTS . 5. Touch Tray 2. 6. Touch Single . Did the page print?	Problem resolved.	Go to step 2.
2	Turn the printer off, and then remove the rear frame cover. See “Rear frame cover removal” on page 4-38 . Check the option cable in connector JOPT1 (A) on the system board for proper connection, for cable pinch points, and for any other damage to the cable or connector  Is the cable damaged?	Replace the option cable. See “Option cable removal” on page 4-115 .	Go to step 3.
3	Remove the right cover. See “Right cover removal” on page 4-39 . Check the option cable for pinch points and any damage.  Is the cable damaged?	Replace the option cable. See “Option cable removal” on page 4-115 .	Go to step 4.
4	Is the option tray 2 the high-capacity input tray (2,000-sheet feeder)?	Replace the HCIT top plate assembly. See “Top plate assembly removal” on page 4-264 .	Replace the option tray 2 assembly.

162.xx, 163.xx—Motor (option tray 3) error service check

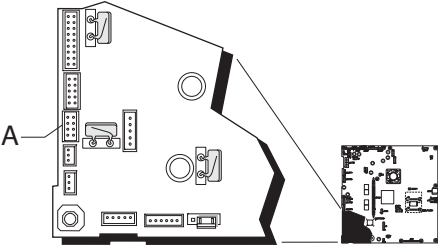
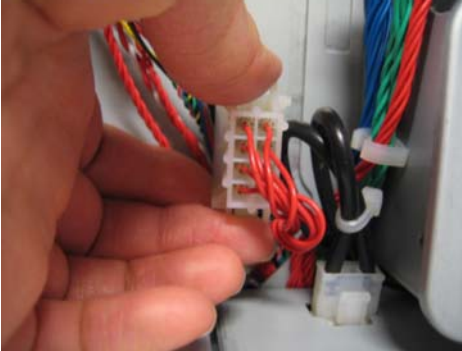
Step	Questions / actions	Yes	No
1	1. Turn the printer off. 2. Reseat option tray 3. 3. Bring the printer up in Diagnostics Menu (turn the multifunction printer off, press and hold 3 and 6 , turn the MFP on, and then release the buttons when the progress bar displays). 4. Touch PRINT TESTS . 5. Touch Tray 3. 6. Touch Single . Did the page print?	Problem resolved.	Go to step 2.
2	Turn the printer off, and then remove the rear frame cover. See “Rear frame cover removal” on page 4-38 . Check the option cable in connector JOPT1 (A) on the system board for proper connection, for cable pinch points, and for any other damage to the cable or connector  Is the cable damaged?	Replace the option cable. See “Option cable removal” on page 4-115 .	Go to step 3.
3	Remove the right cover. See “Right cover removal” on page 4-39 . Check the option cable for pinch points and any damage.  Is the cable damaged?	Replace the option cable. See “Option cable removal” on page 4-115 .	Go to step 4.
4	Is the option tray 3 the high-capacity input tray (2,000-sheet feeder)?	Replace the HCIT top plate assembly. See “Top plate assembly removal” on page 4-264 .	Replace the option tray 3 assembly.

164.xx, 165.xx—Motor Error (option tray 4) service check

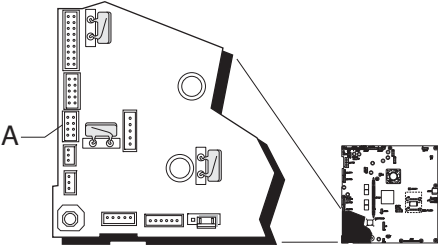
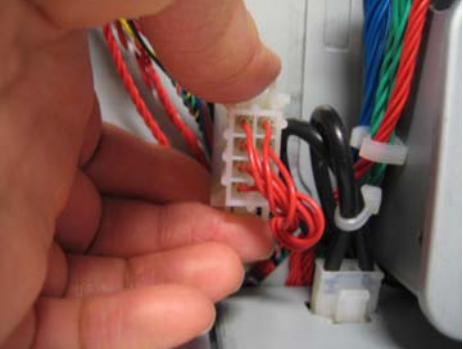
Step	Questions / actions	Yes	No
1	1. Turn the printer off. 2. Reseat option tray 4. 3. Bring the printer up in Diagnostics Menu (turn the multifunction printer off, press and hold 3 and 6 , turn the MFP on, and then release the buttons when the progress bar displays). 4. Touch PRINT TESTS . 5. Touch Tray 4. 6. Touch Single . Did the page print?	Problem resolved.	Go to step 2.
2	Turn the printer off, and then remove the rear frame cover. See “Rear frame cover removal” on page 4-38 . Check the option cable in connector JOPT1 on the system board for proper connection, for cable pinch points, and for any other damage to the cable or connector  Is the cable damaged?	Replace the option cable. See “Option cable removal” on page 4-115 .	Go to step 3.
3	Remove the right cover. See “Right cover removal” on page 4-39 . Check the option cable for pinch points and any damage.  Is the cable damaged?	Replace the option cable. See “Option cable removal” on page 4-115 .	Go to step 4.
4	Is the option tray 4 the high-capacity input tray (2,000-sheet feeder)?	Replace the HCIT top plate assembly. See “24 V interlock switch removal” on page 2-133 .	Replace the option tray 4 assembly.

166.xx, 167.xx—Motor Error (option tray 5) service check

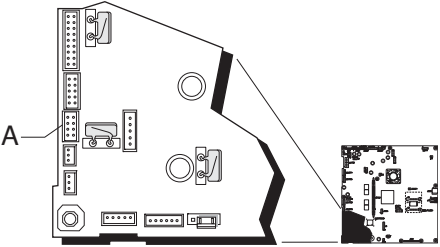
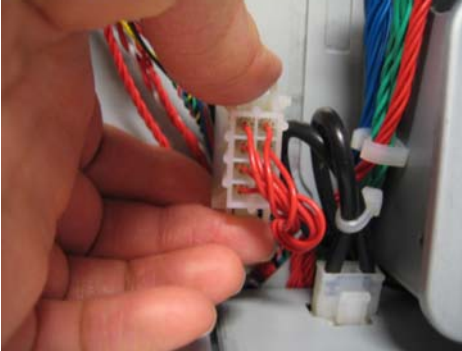
Step	Questions / actions	Yes	No
1	1. Turn the printer off. 2. Reseat option tray 5. 3. Bring the printer up in Diagnostics Menu (turn the multifunction printer off, press and hold 3 and 6 , turn the MFP on, and then release the buttons when the progress bar displays). 4. Touch PRINT TESTS . 5. Touch Tray 5. 6. Touch Single . Did the page print?	Problem resolved.	Go to step 2.
2	Turn the printer off, and then remove the rear frame cover. See “Rear frame cover removal” on page 4-38 . Check the option cable in connector JOPT1 on the system board for proper connection, for cable pinch points, and for any other damage to the cable or connector  Is the cable damaged?	Replace the option cable. See “Option cable removal” on page 4-115 .	Go to step 3.
3	Remove the right cover. See “Right cover removal” on page 4-39 . Check the option cable for pinch points and any damage.  Is the cable damaged?	Replace the option cable. See “Option cable removal” on page 4-115 .	Go to step 4
4	Is the option tray 5 the high-capacity input tray (2,000-sheet feeder)?	Replace the HCIT top plate assembly. See “Top plate assembly removal” on page 4-264 .	Replace the option tray 5 assembly.

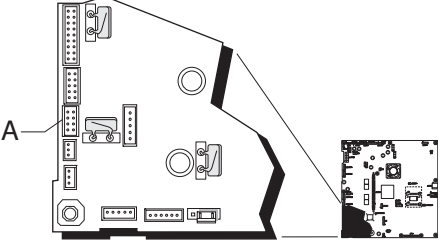

168.xx—Motor (HCIT elevator) error service check

Step	Questions / actions	Yes	No
1	Is the paper properly loaded in the high-capacity input tray (HCIT)?	Go to step 2.	Fan the media, and then stack flat in the HCIT drawer.
2	1. Turn the printer off. 2. Reseat option tray 5. 3. Bring the printer up in Diagnostics Menu (turn the multifunction printer off, press and hold 3 and 6 , turn the MFP on, and then release the buttons when the progress bar displays). 4. Touch PRINT TESTS . 5. Touch HCIT . 6. Touch Single . Did the page print?	Problem resolved.	Go to step 3.
3	Turn the printer off, and then remove the rear frame cover. See “Rear frame cover removal” on page 4-38 . Check the option cable in connector JOPT1 (A) on the system board for proper connection, for cable pinch points, and for any other damage to the cable or connector  Is the cable damaged?	Replace the option cable. See “Option cable removal” on page 4-115 .	Go to step 4.
4	Remove the HCIT right cover. See “HCIT right cover removal” on page 4-253 . Check the cable in the HCIT. Is the cable damaged?	Replace the elevator-up cable. See	Replace the elevator motor motor. See “HCIT elevator motor with sensor removal” on page 4-257 .

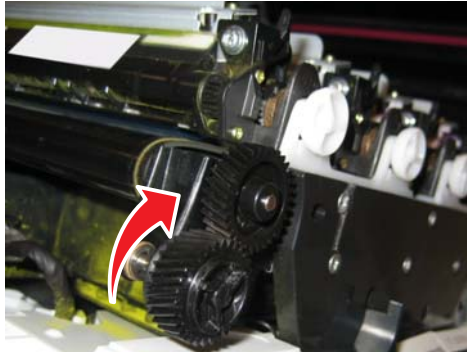
200.11, 250.03—Paper Jam error service check

Step	Questions / actions	Yes	No
1	<p>Open the front access door. Turn the transport belt gear clockwise.</p>  <p>Did the transport belt move?</p>	Go to step 2.	Replace the transport belt. See “Transfer module removal” on page 4-168.
2	<ol style="list-style-type: none"> 1. Disconnect the cable in connector JFDPCK1, and connect the cables for the new paper pick mechanisms. 2. Bring the printer up in Diagnostics Menu (turn the multifunction printer off, press and hold 3 and 6, turn the MFP on, and then release the buttons when the progress bar displays). 3. Touch MOTOR TESTS. 4. Touch Align Motor Test. <p>Can you hear the align motor run?</p>	Go to “Input sensor service check” on page 2-143.	Replace the paper pick mechanism. See “Paper pick mechanism assembly removal” on page 4-117.

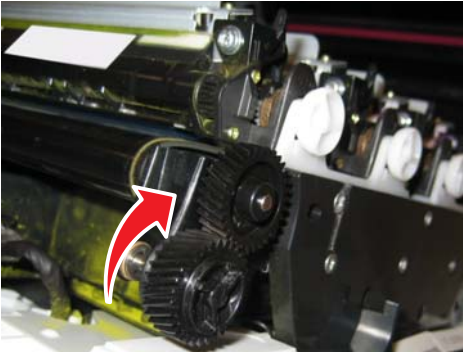

201.06, 201.31—Paper Jam error service check

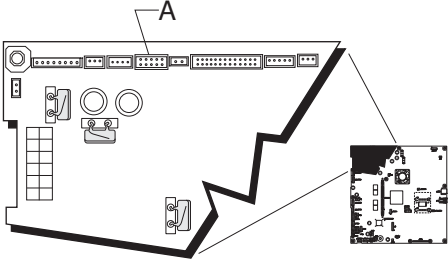
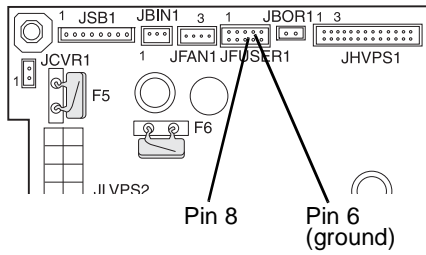
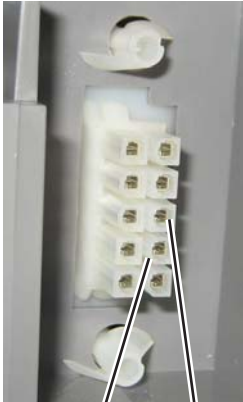
Step	Questions / actions	Yes	No
1	<p>Open the front access door. Turn the transport belt gear clockwise.</p>  <p>Did the transport belt move?</p>	Go to step 2.	Replace the transport belt. See “Transfer module removal” on page 4-168.
2	<p>Bring the printer up in Diagnostics Menu (turn the multifunction printer off, press and hold 3 and 6, turn the MFP on, and then release the buttons when the progress bar displays). Perform the Align Motor Test. See “Motor tests” on page 3-12.</p> <p>Can you hear the align motor run?</p>	Go to step 3.	Replace the paper pick mechanism. See “Paper pick mechanism assembly removal” on page 4-117.
3	<p>Turn the printer off, and then remove the fuser. See “Fuser assembly removal” on page 4-94.</p>  <p>Is the exit sensor flag damaged?</p>	Replace the fuser. See “Fuser assembly removal” on page 4-94.	Go to step 4.
4	<p>Verify the paper is loaded properly in the paper tray or manual feed slot. Is the paper properly loaded?</p>	Go to step 5.	Load paper.
5	<p>Replace the fuser. See “Fuser assembly removal” on page 4-94. POR the printer. Did the error clear?</p>	Problem resolved.	Replace the original fuser, and go to step 6.

Step	Questions / actions	Yes	No
6	<p>Remove the rear frame cover. See “Rear frame cover removal” on page 4-38.</p> <p>Check the fuser DC cable in the connector JFUSER1 for proper connection to the system board, for pinch points, and for any other damage to the cable or the connector.</p>  <p>Is the cable damaged?</p>	<p>Replace the fuser DC cable. See “Fuser DC cable removal” on page 4-97.</p>	<p>Go to step 7.</p>
7	<ol style="list-style-type: none"> POR the printer. Place a voltmeter between pin 8 and pin 6 on the JFUSER1 connector.  <ol style="list-style-type: none"> Does the meter read +5 V dc? 	<p>Go to step 8.</p>	<p>Replace the system board. See “System board removal” on page 4-148.</p>
8	<p>Place a voltmeter between the fuser DC autoconnect pin 8 and ground (pin 6).</p>  <p>Does the meter read +5 V dc?</p>	<p>Go to step 9.</p>	<p>Replace the fuser DC cable. See “Fuser DC cable removal” on page 4-97.</p>

Step	Questions / actions	Yes	No
9	<ol style="list-style-type: none"> 1. Replace the fuser. 2. Bring the printer up in the Diagnostics menu (turn off the printer, press and hold 3 and 6, turn on the printer.) 3. Touch SENSOR TESTS. 4. Touch Dynamic Sensors. 5. Touch Fuser Exit. 6. Open the front access door, and the top access cover. 7. Activate the fuser exit sensor.  <p>Did the fuser exit sensor change from Open to Closed on the touchscreen?</p>	Problem resolved.	Replace the system board. See “System board removal” on page 4-148.

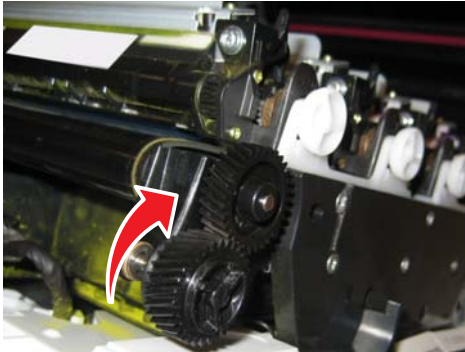
203.09—Paper Jam error service check

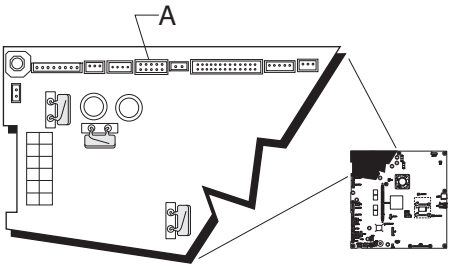
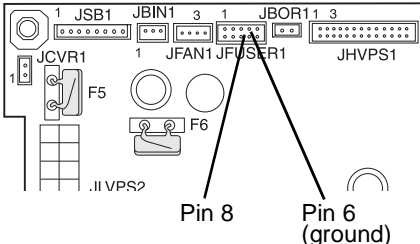
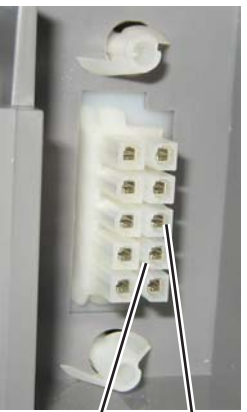

Step	Questions / actions	Yes	No
1	<p>Open the front access door. Turn the transport belt gear clockwise.</p>  <p>Did the transport belt move?</p>	Go to step 2.	Replace the transport belt. See “Transfer module removal” on page 4-168.
2	<p>Turn the printer off, and then remove the fuser. See “Fuser assembly removal” on page 4-94.</p>  <p>Is the exit sensor flag damaged?</p>	Replace the fuser. See “Fuser assembly removal” on page 4-94.	Go to step 3.
3	<p>Verify the paper is loaded properly in the paper tray or manual feed slot.</p> <p>Is the paper properly loaded?</p>	Go to step 4.	Load paper.
4	<p>Replace the fuser. See “Fuser assembly removal” on page 4-94.</p> <p>POR the printer.</p> <p>Did the error clear?</p>	Problem resolved.	Replace the original fuser, and go to step 5.

Step	Questions / actions	Yes	No
<p>5</p>	<p>Remove the rear frame cover. See “Rear frame cover removal” on page 4-38.</p> <p>Check the fuser DC cable in the connector JFUSER1 for proper connection to the system board, for pinch points, and for any other damage to the cable or the connector.</p>  <p>Is the cable damaged?</p>	<p>Replace the fuser DC cable. See “Fuser DC cable removal” on page 4-97.</p>	<p>Go to step 6.</p>
<p>6</p>	<p>POR the printer.</p> <p>Place a voltmeter between the JFUSER1 pin 8 and ground (pin 6).</p>  <p>Does the meter read +5 V dc?</p>	<p>Go to step 7.</p>	<p>Replace the system board. See “System board removal” on page 4-148.</p>
<p>7</p>	<p>Place a voltmeter between the fuser DC autoconnect pin 8 and ground (pin 6).</p>  <p>Does the meter read +5 V dc?</p>	<p>Go to step 8.</p>	<p>Replace the fuser DC cable. See “Fuser DC cable removal” on page 4-97.</p>

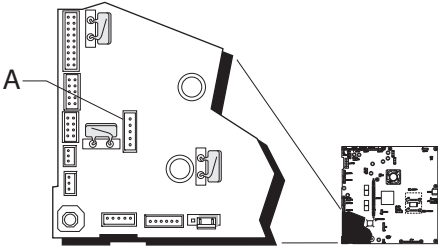

Step	Questions / actions	Yes	No
8	<ol style="list-style-type: none"> 1. Replace the fuser. 2. Bring the printer up in the Diagnostics menu (turn off the printer, press and hold 3 and 6, turn on the printer.) 3. Touch SENSOR TESTS. 4. Touch Dynamic Sensors. 5. Touch Fuser Exit. 6. Open the front access door, and the top access cover. 7. Activate the fuser exit sensor.  <p>Did the fuser exit sensor change from Open to Closed on the touchscreen?</p>	Problem resolved.	Replace the system board. See “System board removal” on page 4-148.

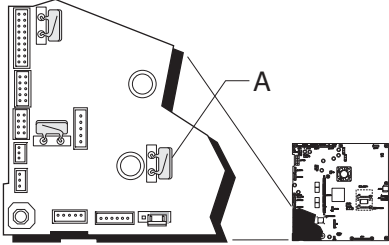
230.03, 230.05—Paper Jam error service check

Step	Questions / actions	Yes	No
1	Is the paper fan-folded	Replace the front door assembly. See “Front door assembly removal” on page 4-83.	Go to step 2.
2	<p>Turn the printer off, and then remove the rear frame cover. See “Rear frame cover removal” on page 4-38.</p> <p>Check the MPF/duplex motor cable in connector JDX1 for proper connection to the system board, cable pinch points, and any other damage to the cable or connector.</p>  <p>Is the cable damaged?</p>	Replace the fuser DC cable. See “Fuser DC cable removal” on page 4-97.	Go to step 3.

Step	Questions / actions	Yes	No
3	<p>Measure the resistance across fuse F13 on the system board.</p>  <p>Is the fuse blown?</p>	<p>Replace the system board. See “System board removal” on page 4-148.</p>	<p>Go to step 4.</p>
4	<p>Is the front door assembly damaged?.</p> 	<p>Replace the front door assembly. See “Front door assembly removal” on page 4-83.</p>	<p>Go to step 5.</p>
5	<p>Check the MPF/duplex gear assembly for damage.</p>  <p>Are the gears damaged?</p>	<p>Replace the MPF/duplex gear assembly. See “Multipurpose feeder (MPF)/duplex gear and housing removal” on page 4-108.</p>	<p>Go to step 6.</p>
6	<p>Replace the MPF/duplex motor assembly. See “Multipurpose feeder (MPF)/duplex motor assembly removal” on page 4-110.</p> <p>Does the error clear?</p>	<p>Problem resolved.</p>	<p>Go to “Input sensor service check” on page 2-143.</p>

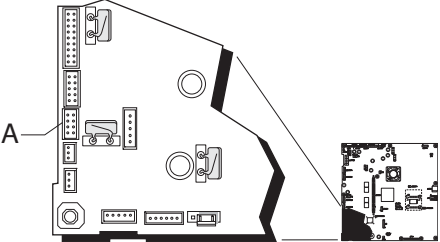
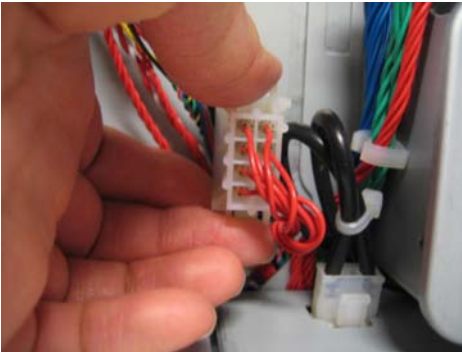
242.02—Paper Jam error service check

Step	Questions / actions	Yes	No
1	Has paper been fed from an input option before?	Go to step 4.	Go to step 2.
2	<p>1. Turn the printer off.</p> <p>2. Remove the rear frame cover. See “Rear frame cover removal” on page 4-38.</p> <p>3. Remove the left cover. See “Left cover removal” on page 4-23.</p> <p>4. Check the entire length of the cable in connector JOPT1 for proper connection to the system board, cable pinch points, and any other damage to the cable or connector.</p>   <p>Is the cable damaged?</p>	Replace the option cable. See “Option cable removal” on page 4-115	Go to step 3.
3	<p>Carefully lift the printer off the option, and lay the printer on its back. Check the option connector for damage.</p>  <p>Is the option cable connector or cable damaged?</p>	Replace the option cable. See “Option cable removal” on page 4-115.	Go to step 4.

Step	Questions / actions	Yes	No
4	Replace the option tray 2. Does the error clear?	Problem resolved.	Replace the system board. See “System board removal” on page 4-148.

242.03, 242.11—Paper Jam service check

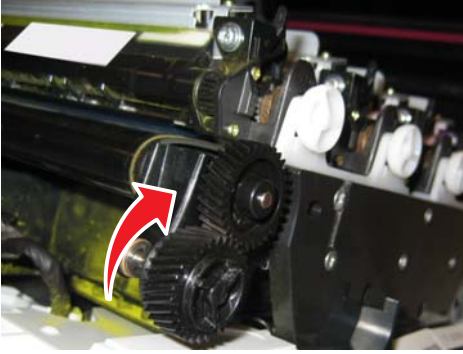
Step	Questions / actions	Yes	No
1	<ol style="list-style-type: none"> Bring the printer up in Diagnostics Menu (turn the multifunction printer off, press and hold 3 and 6, turn the MFP on, and then release the buttons when the progress bar displays). Touch PRINT TESTS. Select a tray below tray 2. Touch Single. Did the page print correctly?	Problem resolved.	Go to step 2.
2	<ol style="list-style-type: none"> Turn the printer off. Open the front access door. Turn the transport belt gear clockwise.  Did the transport belt move?	Go to step 3	Replace the transport belt. See “Transfer module removal” on page 4-168.
3	<ol style="list-style-type: none"> Bring the printer up in Diagnostics Menu (turn the multifunction printer off, press and hold 3 and 6, turn the MFP on, and then release the buttons when the progress bar displays). Touch MOTOR TESTS. Touch Align Motor Test. Can you hear the align motor run?	Go to step 4.	Replace the paper pick mechanism. See “Paper pick mechanism assembly removal” on page 4-117.
4	Is tray 2 a high-capacity input option (2,000-sheet feeder)?	Replace the HCIT top plate. See “Top plate assembly removal” on page 4-264.	Replace the complete tray 2 option.

242.05—Paper Jam service check

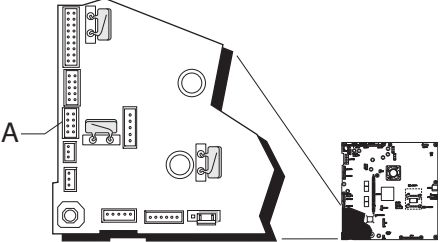
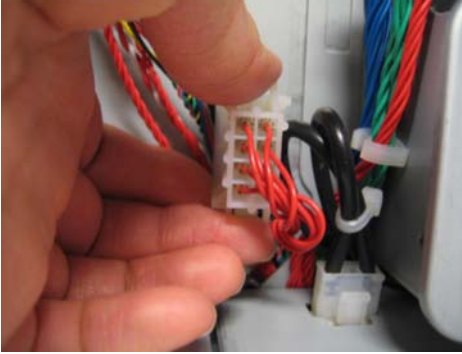
Step	Questions / actions	Yes	No
1	Has the paper been fed from an input option before?	Go to step 5.	Go to step 2.
2	<ol style="list-style-type: none"> 1. Bring the printer up in Diagnostics Menu (turn the multifunction printer off, press and hold 3 and 6, turn the MFP on, and then release the buttons when the progress bar displays). 2. Select Print Tests. 3. Select a tray below tray 2. 4. Select Single. Did the page feed correctly?	Problem resolved.	Go to step 3.
3	<ol style="list-style-type: none"> 1. Turn the printer off. 2. Remove the rear frame cover. See “Rear frame cover removal” on page 4-38. 3. Remove the right cover. See “Right cover removal” on page 4-39. Check the cable in connector JOPT1 (A) for proper connection to the system board, cable pinch points, and any other damage to the cable or connector.   Is the cable damaged?	Replace the option cable. See “Option cable removal” on page 4-115.	Go to step 4.

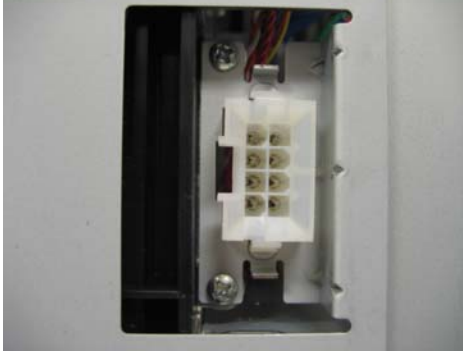
Step	Questions / actions	Yes	No
4	<p>Carefully lift the printer off the option, and lay the printer on its back.</p> <p>Check the option connector for damage.</p>  <p>Is the connector damaged?</p>	<p>Replace the option cable. See “Option cable removal” on page 4-115.</p>	<p>Go to step 5.</p>
5	<p>Is tray 2 a high-capacity input tray (2,000-sheet feeder)?</p>	<p>Go to step 7.</p>	<p>Go to step 6.</p>
6	<p>Replace the tray 2 option.</p> <p>Does the error clear?</p>	<p>Problem resolved.</p>	<p>Replace the system board. See “System board removal” on page 4-148.</p>
7	<p>Replace the HCIT top plate. See “Top plate assembly removal” on page 4-264.</p>	<p>Problem resolved.</p>	<p>Replace the system board. See “System board removal” on page 4-148.</p>

242.10—Paper Jam service check

Step	Questions / actions	Yes	No
1	<ol style="list-style-type: none"> 1. Bring the printer up in Diagnostics Menu (turn the multifunction printer off, press and hold 3 and 6, turn the MFP on, and then release the buttons when the progress bar displays). 2. Touch PRINT TESTS. 3. Select a tray below tray 2. 4. Touch Single. <p>Did the page print correctly?</p>	<p>Problem resolved.</p>	<p>Replace the complete tray 2 option.</p>

242.17—Paper Jam service check

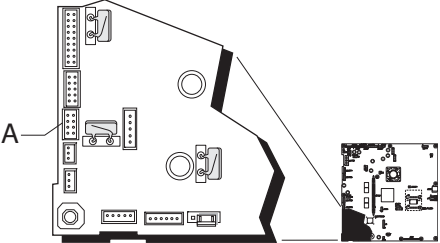
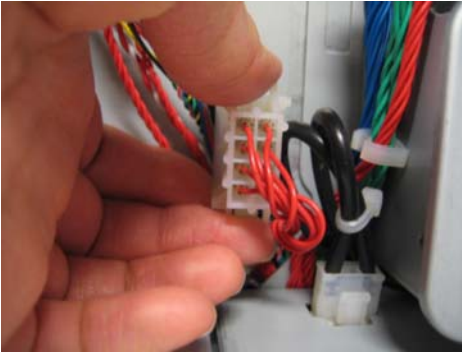
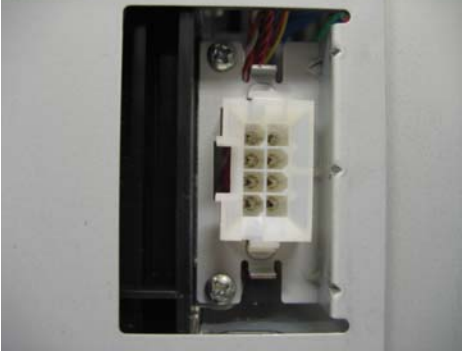
Step	Questions / actions	Yes	No
1	Has paper been fed from an input option before?	Go to step 4.	Go to step 2.
2	<p>Turn the printer off, and then remove the rear frame cover. See “Rear frame cover removal” on page 4-38. Remove the right cover. See “Right cover removal” on page 4-39.</p> <p>Check the cable in connector JOPT1 (A) for proper connection to the system board, cable pinch points, and any other damage to the cable or connector.</p>   <p>Is the cable damaged?</p>	Replace the option cable. See “Option cable removal” on page 4-115 .	Go to step 3.
3	<p>Carefully lift the printer off the option, and lay the printer on its back. Check the option connector for damage.</p>  <p>Is the option cable connector or cable damaged?</p>	Replace the option cable. See “Option cable removal” on page 4-115 .	Go to step 4.

Step	Questions / actions	Yes	No
4	Is tray 2 an high-capacity input tray (HCIT)?	Replace the HCIT top plate. See “Top plate assembly removal” on page 4-264.	Replace the complete tray 2 option.

242.26—Paper Jam service check

Step	Questions / actions	Yes	No
1	<ol style="list-style-type: none"> Determine the input tray. Touch Menus ()—Paper Menu—Default Source. Bring the printer up in Diagnostics Menu (turn the multifunction printer off, press and hold 3 and 6, turn the MFP on, and then release the buttons when the progress bar displays). Touch PRINT TESTS. Select a tray you determined in step 1. Touch Single. 	Problem resolved.	Go to step 2
2	Is the tray 3 a high-capacity input tray (2,000-sheet feeder)?	Replace the HCIT top plate. See “Top plate assembly removal” on page 4-264.	Replace the complete tray 3 option.

242.27—Paper Jam service check

Step	Questions / actions	Yes	No
1	<ol style="list-style-type: none"> Bring the printer up in Diagnostics Menu (turn the multifunction printer off, press and hold 3 and 6, turn the MFP on, and then release the buttons when the progress bar displays). Touch PRINT TESTS. Select a tray below tray 2. Touch Single. <p>Did the page print correctly?</p>	Problem resolved.	Go to step 2.

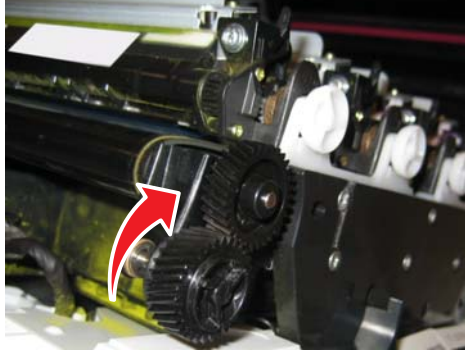
Step	Questions / actions	Yes	No
2	<ol style="list-style-type: none"> 1. Turn the printer off. 2. Open the front access door. 3. Turn the transport belt gear clockwise.  <p>Did the transport belt move?</p>	Go to step 3.	Replace the transport belt. See “Transfer module removal” on page 4-168.
3	<ol style="list-style-type: none"> 1. Bring the printer up in Diagnostics Menu (turn the multifunction printer off, press and hold 3 and 6, turn the MFP on, and then release the buttons when the progress bar displays). 2. Touch MOTOR TESTS. 3. Touch Align Motor. <p>Can you hear the align motor run?</p>	Replace the complete tray 2 option.	Replace the paper pick mechanism. See “Paper pick mechanism assembly removal” on page 4-117.

242.29—Paper Jam service check

Step	Questions / actions	Yes	No
1	<p>Bring the printer up in Diagnostics Menu (turn the multifunction printer off, press and hold 3 and 6, turn the MFP on, and then release the buttons when the progress bar displays).</p> <p>Perform the Sensor Test for the option tray 2 tray present sensor.</p> <p>Does the sensor test work correctly?</p>	Problem resolved	Go to step 2.
2	Is tray 2 a high-capacity input tray (2,000-sheet feeder)?	Replace the HCIT elevator up sensor. See “HCIT elevator motor with sensor removal” on page 4-257.	Replace the complete tray 2 option.

243.02—Paper Jam service check

Step	Questions / actions	Yes	No
1	Has paper been fed from an input option before?	Go to step 4.	Go to step 2.

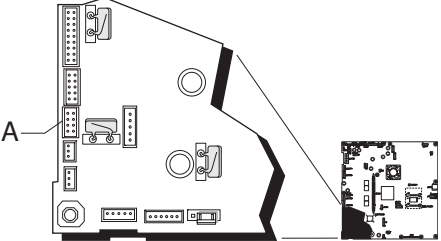
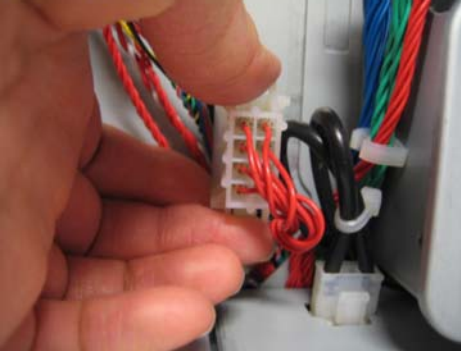
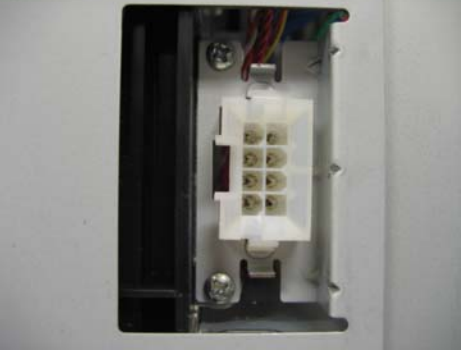
Step	Questions / actions	Yes	No
2	<p>1. Turn the printer off.</p> <p>2. Remove the rear frame cover. See “Rear frame cover removal” on page 4-38.</p> <p>3. Remove the right cover. See “Right cover removal” on page 4-39.</p> <p>4. Check the connector JOPT1 for proper connection to the system board, the cable for pinch points, and the cable or connector for any other damage.</p>   <p>Is the cable damaged?</p>	<p>Replace the option cable. See “Option cable removal” on page 4-115.</p>	<p>Go to step 3.</p>
3	<p>Carefully lift the printer off the option, and lay the printer on its back.</p> <p>Check the option connector for damage.</p>  <p>Is the connector damaged?</p>	<p>Replace the option cable. See “Option cable removal” on page 4-115.</p>	<p>Go to step 4.</p>
4	<p>Replace the complete tray 3 option.</p> <p>Does the error clear?</p>	<p>Problem resolved.</p>	<p>Replace the system board. See “System board removal” on page 4-148.</p>

243.03, 243.11—Paper Jam service check

Step	Questions / actions	Yes	No
1	1. Bring the printer up in Diagnostics Menu (turn the multifunction printer off, press and hold 3 and 6 , turn the MFP on, and then release the buttons when the progress bar displays). 2. Touch PRINT TESTS . 3. Select a tray below tray 3. 4. Touch Single . Did the page print correctly?	Problem resolved.	Go to step 2.
2	Is tray 3 a high-capacity input option (2,000-sheet feeder)?	Replace the HCIT top plate. See “Top plate assembly removal” on page 4-264.	Replace the complete tray 3 option.

243.05—Paper Jam service check

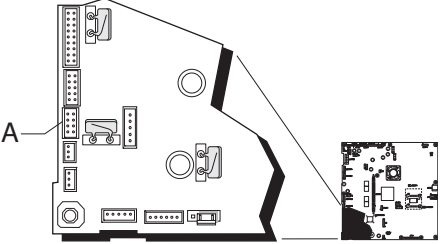
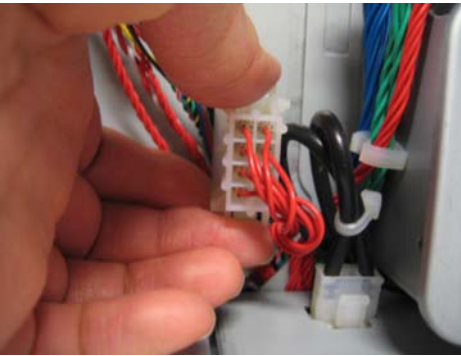
Step	Questions / actions	Yes	No
1	Has paper been fed from an input option before?	Go to step 5.	Go to step 2.
2	<ol style="list-style-type: none"> 1. Bring the printer up in Diagnostics Menu (turn the multifunction printer off, press and hold 3 and 6, turn the MFP on, and then release the buttons when the progress bar displays). 2. Touch PRINT TESTS. 3. Select a tray below tray 3. 4. Touch Single. Did the page print correctly?	Problem resolved.	Go to step 3.
3	<ol style="list-style-type: none"> 1. Turn the printer off. 2. Remove the rear frame cover. See “Rear frame cover removal” on page 4-38. 3. Remove the right cover. See “Right cover removal” on page 4-39. 4. Check the connector at JOPT1 on the system board for proper connection, the cable for pinch points, and the cable or connector for any other damage. <div style="text-align: center;">  </div> <div style="text-align: center;">  </div> <p>Is the cable damaged?</p>	Replace the option cable.	Go to step 4.

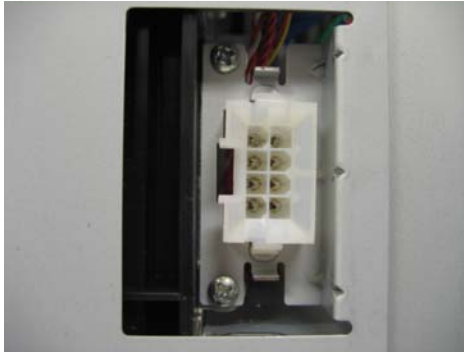
Step	Questions / actions	Yes	No
4	<p>Carefully lift the printer off the option, and lay the printer on its back.</p> <p>Check the option connector for damage.</p>  <p>Is the connector damaged?</p>	<p>Replace the option cable. See “Option cable removal” on page 4-115.</p>	<p>Go to step 5.</p>
5	<p>Is tray 3 a high-capacity input option (2,000-sheet feeder)?</p>	<p>Go to step 7.</p>	<p>Go to step 6.</p>
6	<p>Replace the complete tray 3 option.</p> <p>Does the error clear?</p>	<p>Problem resolved.</p>	<p>Replace the system board. See “System board removal” on page 4-148.</p>
7	<p>Replace the high-capacity input tray (2,000-sheet feeder)?</p>	<p>Problem resolved.</p>	<p>Replace the system board. See “System board removal” on page 4-148.</p>

243.10—Paper Jam service check

Step	Questions / actions	Yes	No
1	<ol style="list-style-type: none"> 1. Bring the printer up in Diagnostics Menu (turn the multifunction printer off, press and hold 3 and 6, turn the MFP on, and then release the buttons when the progress bar displays). 2. Select PRINT TESTS. 3. Select a tray below tray 3. 4. Select Single. <p>Did the page feed correctly?</p>	<p>Problem resolved</p>	<p>Replace the complete tray 3 option.</p>

243.17—Paper Jam service check

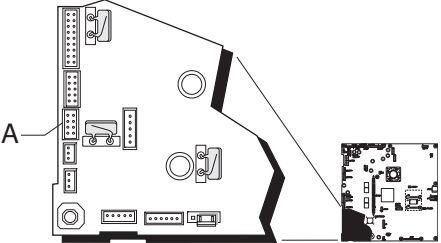
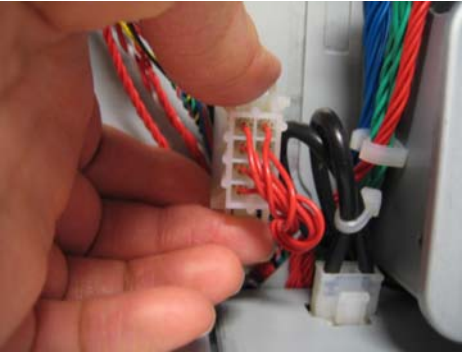
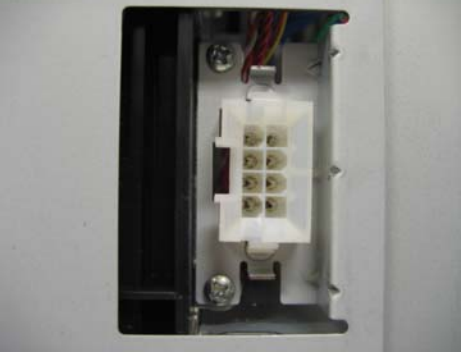
Step	Questions / actions	Yes	No
1	Has paper been fed from an input option before?	Go to step 4.	Go to step 2.
2	<p>Turn the printer off, and then remove the rear frame cover. See “Rear frame cover removal” on page 4-38. Remove the right cover. See “Right cover removal” on page 4-39.</p> <p>Check the cable in connector JOPT1 (A) for proper connection to the system board, cable pinch points, and any other damage to the cable or connector.</p>   <p>Is the cable damaged?</p>	Replace the option cable. See “Option cable removal” on page 4-115 .	Go to step 3.
3	<p>Carefully lift the printer off the option, and lay the printer on its back. Check the option connector for damage.</p>  <p>Is the option cable connector or cable damaged?</p>	Replace the option cable. See “Option cable removal” on page 4-115 .	Go to step 4.

Step	Questions / actions	Yes	No
4	Is tray 3 an high-capacity input tray (HCIT)?	Replace the HCIT top plate. See “Top plate assembly removal” on page 4-264.	Replace the complete tray 3 option.

243.26—Paper Jam service check

Step	Questions / actions	Yes	No
1	<ol style="list-style-type: none"> Determine the input tray. Bring the printer up in Diagnostics Menu (turn the multifunction printer off, press and hold 3 and 6, turn the MFP on, and then release the buttons when the progress bar displays). Select PRINT TESTS. Select indicated. Select Single. Did the page feed correctly?	Problem resolved	Go to step 2.
2	Is tray 2 a high-capacity input tray (2,000-sheet feeder)?	Replace the HCIT top plate. See “Top plate assembly removal” on page 4-264.	Replace the complete tray 4 option.

243.27—Paper Jam service check

Step	Questions / actions	Yes	No
1	<ol style="list-style-type: none"> Bring the printer up in Diagnostics Menu (turn the multifunction printer off, press and hold 3 and 6, turn the MFP on, and then release the buttons when the progress bar displays). Select PRINT TESTS. Select a tray below tray 4. Select Single. Did the page feed correctly?	Problem resolved.	Replace the complete tray 4 option.

243.29—Paper Jam service check

Step	Questions / actions	Yes	No
1	<ol style="list-style-type: none"> Bring the printer up in Diagnostics Menu (turn the multifunction printer off, press and hold 3 and 6, turn the MFP on, and then release the buttons when the progress bar displays). Select PRINT TESTS. Select Tray 3. Select Single. Did the page feed correctly?	Problem resolved.	Go to step 2.

Step	Questions / actions	Yes	No
2	Is tray 3 a high-capacity input tray (2,000-sheet feeder)?	Replace the HCIT elevator-up sensor. See “HCIT elevator motor with sensor removal” on page 4-257.	Replace the complete tray 3 option.

244.02—Paper Jam service check

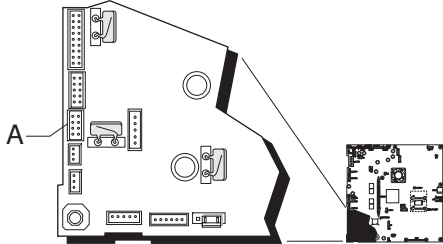
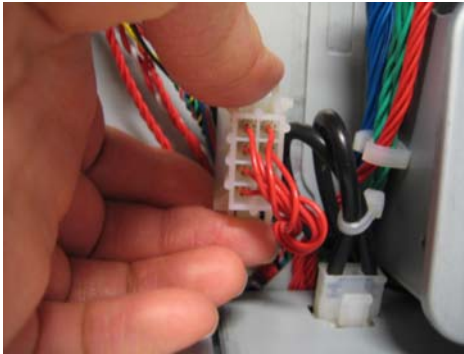
Step	Questions / actions	Yes	No
1	Has paper been fed from an input option before?	Go to step 4.	Go to step 2.
2	<p>1. Turn the printer off.</p> <p>2. Remove the rear frame cover. See “Rear frame cover removal” on page 4-38.</p> <p>3. Remove the right cover. See “Right cover removal” on page 4-39.</p> <p>4. Check the connector JOPT1 for proper connection to the system board, the cable for pinch points, and the cable or connector for any other damage.</p>   <p>Is the cable damaged?</p>	Replace the option cable. See “Option cable removal” on page 4-115.	Go to step 3.

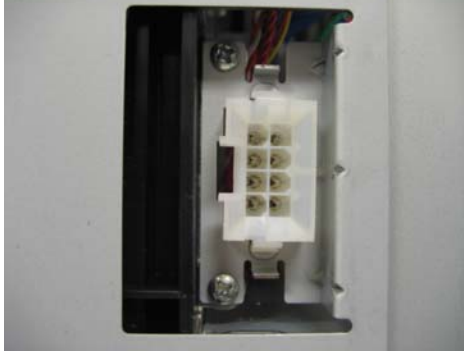
Step	Questions / actions	Yes	No
3	<p>Carefully lift the printer off the options, and lay the printer on its back.</p> <p>Check the option connector for damage.</p>  <p>Is the connector damaged?</p>	<p>Replace the option cable. See “Option cable removal” on page 4-115.</p>	<p>Go to step 4.</p>
4	<p>Replace the complete tray 4 option.</p> <p>Does the error clear?</p>	<p>Problem resolved.</p>	<p>Replace the system board. See “System board removal” on page 4-148.</p>

244.03, 244.11—Paper Jam service check

Step	Questions / actions	Yes	No
1	<ol style="list-style-type: none"> 1. Bring the printer up in Diagnostics Menu (turn the multifunction printer off, press and hold 3 and 6, turn the MFP on, and then release the buttons when the progress bar displays). 2. Touch PRINT TESTS. 3. Select a tray below tray 4. 4. Touch Single. <p>Did the page print correctly?</p>	<p>Problem resolved.</p>	<p>Go to step 2.</p>
2	<p>Is tray 4 a high-capacity input option (2,000-sheet feeder)?</p>	<p>Replace the HCIT top plate. See “Top plate assembly removal” on page 4-264.</p>	<p>Replace the complete tray 4 option.</p>

244.05—Paper Jam service check

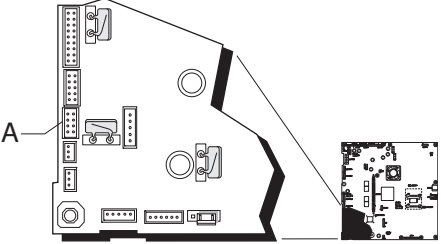
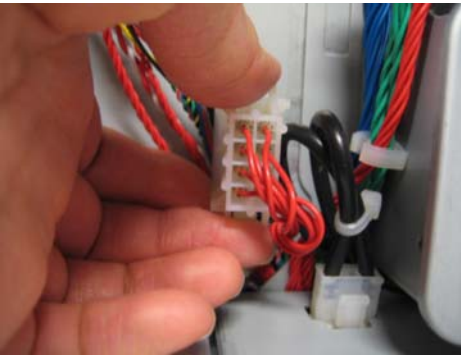
Step	Questions / actions	Yes	No
1	Has paper been fed from an input option before?	Go to step 5.	Go to step 2.
2	1. Bring the printer up in Diagnostics Menu (turn the multifunction printer off, press and hold 3 and 6 , turn the MFP on, and then release the buttons when the progress bar displays). 2. Select PRINT TESTS . 3. Select a tray below tray 3. 4. Select Single . Did the page print correctly?	Problem resolved.	Go to step 3.
3	1. Turn the printer off. 2. Remove the rear frame cover. See “Rear frame cover removal” on page 4-38 . 3. Remove the right cover. See “Right cover removal” on page 4-39 . 4. Check the connector at JOPT1 on the system board for proper connection, the cable for pinch points, and the cable or connector for any other damage.   Is the cable damaged?	Replace the option cable.	Go to step 4.

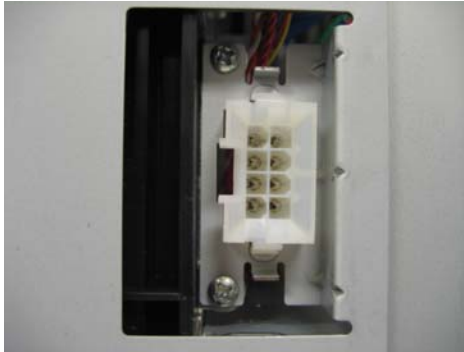
Step	Questions / actions	Yes	No
4	<p>Carefully lift the printer off the option, and lay the printer on its back.</p> <p>Check the option connector for damage.</p>  <p>Is the connector damaged?</p>	<p>Replace the option cable. See “Option cable removal” on page 4-115.</p>	<p>Go to step 5.</p>
5	<p>Is tray 4 a high-capacity input option (2,000-sheet feeder)?</p>	<p>Go to step 7.</p>	<p>Go to step 6.</p>
6	<p>Replace the complete tray 4 option.</p> <p>Does the error clear?</p>	<p>Problem resolved.</p>	<p>Replace the system board. See “System board removal” on page 4-148.</p>
7	<p>Replace the high-capacity input tray (2,000-sheet feeder)?</p>	<p>Problem resolved.</p>	<p>Replace the system board. See “System board removal” on page 4-148.</p>

244.10—Paper Jam service check

Step	Questions / actions	Yes	No
1	<ol style="list-style-type: none"> 1. Bring the printer up in Diagnostics Menu (turn the multifunction printer off, press and hold 3 and 6, turn the MFP on, and then release the buttons when the progress bar displays). 2. Select PRINT TESTS. 3. Select a tray below tray 4. 4. Select Single. <p>Did the page feed correctly?</p>	<p>Problem resolved</p>	<p>Replace the complete tray 4 option.</p>

244.17—Paper Jam service check

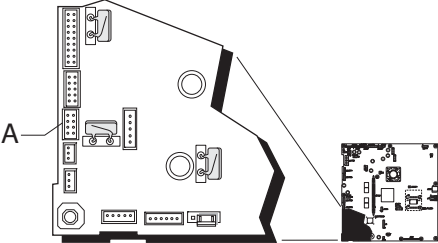
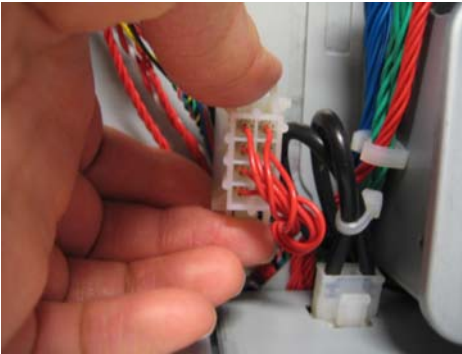
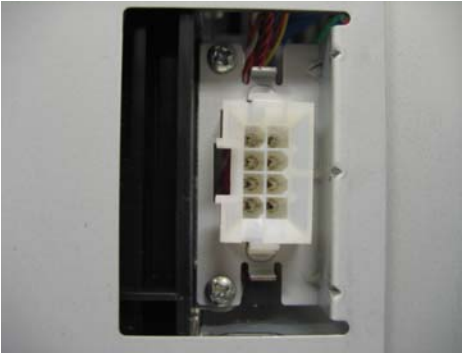
Step	Questions / actions	Yes	No
1	Has paper been fed from an input option before?	Go to step 4.	Go to step 2.
2	<p>Turn the printer off, and then remove the rear frame cover. See “Rear frame cover removal” on page 4-38. Remove the right cover. See “Right cover removal” on page 4-39.</p> <p>Check the cable in connector JOPT1 (A) for proper connection to the system board, cable pinch points, and any other damage to the cable or connector.</p>   <p>Is the cable damaged?</p>	<p>Replace the option cable. See “Option cable removal” on page 4-115.</p>	Go to step 3.
3	<p>Carefully lift the printer off the option, and lay the printer on its back. Check the option connector for damage.</p>  <p>Is the option cable connector or cable damaged?</p>	<p>Replace the option cable. See “Option cable removal” on page 4-115.</p>	Go to step 4.

Step	Questions / actions	Yes	No
4	Is tray 4 an high-capacity input tray (HCIT)?	Replace the HCIT top plate. See “Top plate assembly removal” on page 4-264.	Replace the complete tray 4 option.

244.26—Paper Jam service check

Step	Questions / actions	Yes	No
1	<ol style="list-style-type: none"> Determine the input tray. Bring the printer up in Diagnostics Menu (turn the multifunction printer off, press and hold 3 and 6, turn the MFP on, and then release the buttons when the progress bar displays). Select PRINT TESTS. Select the input tray. Select Single. Did the page feed correctly?	Problem resolved	Go to step 2.
2	Is tray 5 a high-capacity input tray (2,000-sheet feeder)?	Replace the HCIT top plate. See “Top plate assembly removal” on page 4-264.	Replace the complete tray 5 option.

244.27—Paper Jam service check

Step	Questions / actions	Yes	No
1	<ol style="list-style-type: none"> Bring the printer up in Diagnostics Menu (turn the multifunction printer off, press and hold 3 and 6, turn the MFP on, and then release the buttons when the progress bar displays). Select PRINT TESTS. Select a tray below tray 3. Select Single. Did the page feed correctly?	Problem resolved.	Replace the complete tray 4 option.

244.29—Paper Jam service check

Step	Questions / actions	Yes	No
1	<ol style="list-style-type: none"> Bring the printer up in Diagnostics Menu (turn the multifunction printer off, press and hold 3 and 6, turn the MFP on, and then release the buttons when the progress bar displays). Select PRINT TESTS. Select Tray 4. Select Single. Did the page feed correctly?	Problem resolved.	Go to step 2.

Step	Questions / actions	Yes	No
2	Is tray 4 a high-capacity input tray (2,000-sheet feeder)?	Replace the HCIT elevator-up sensor. See “HCIT elevator motor with sensor removal” on page 4-257.	Replace the complete tray 4 option.

245.02—Paper Jam service check

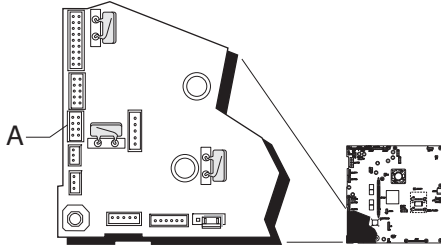
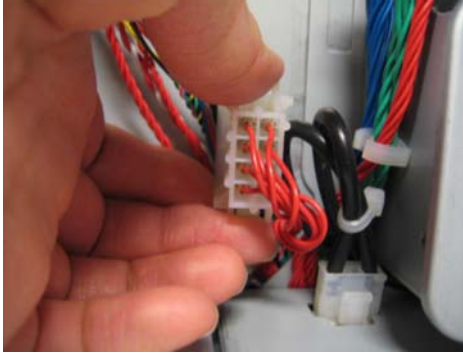
Step	Questions / actions	Yes	No
1	Has paper been fed from an input option before?	Go to step 4.	Go to step 2.
2	<ol style="list-style-type: none"> 1. Turn the printer off. 2. Remove the rear frame cover. See “Rear frame cover removal” on page 4-38. 3. Remove the right cover. See “Right cover removal” on page 4-39. 4. Check the connector JOPT1 for proper connection to the system board, the cable for pinch points, and the cable or connector for any other damage.   <p>Is the cable damaged?</p>	Replace the option cable. See “Option cable removal” on page 4-115.	Go to step 3.

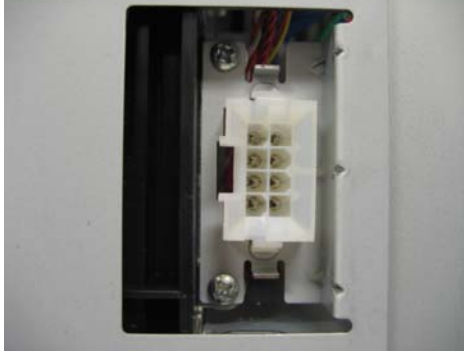
Step	Questions / actions	Yes	No
3	<p>Carefully lift the printer off the options, and lay the printer on its back.</p> <p>Check the option connector for damage.</p>  <p>Is the connector damaged?</p>	<p>Replace the option cable. See “Option cable removal” on page 4-115.</p>	<p>Go to step 4.</p>
4	<p>Replace the complete tray 5 option.</p> <p>Does the error clear?</p>	<p>Problem resolved.</p>	<p>Replace the system board. See “System board removal” on page 4-148.</p>

245.03, 245.11—Paper Jam service check

Step	Questions / actions	Yes	No
1	<ol style="list-style-type: none"> 1. ring the printer up in Diagnostics Menu (turn the multifunction printer off, press and hold 3 and 6, turn the MFP on, and then release the buttons when the progress bar displays). 2. Select PRINT TESTS. 3. Select a tray below tray 3. 4. Select Single. <p>Did the page print correctly?</p>	<p>Problem resolved.</p>	<p>Go to step 2.</p>
2	<p>Is tray 5 a high-capacity input option (2,000-sheet feeder)?</p>	<p>Replace the HCIT top plate. See “Top plate assembly removal” on page 4-264.</p>	<p>Replace the complete tray 5 option.</p>

245.05—Paper Jam service check

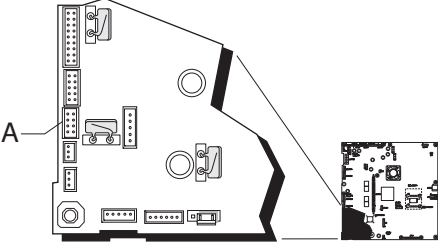
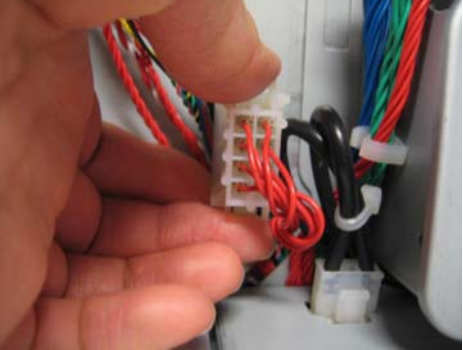
Step	Questions / actions	Yes	No
1	Has paper been fed from an input option before?	Go to step 5.	Go to step 2.
2	1. Bring the printer up in Diagnostics Menu (turn the multifunction printer off, press and hold 3 and 6 , turn the MFP on, and then release the buttons when the progress bar displays). 2. Select PRINT TESTS . 3. Select Tray 5 . 4. Select Single . Did the page print correctly?	Problem resolved.	Go to step 3.
3	1. Turn the printer off. 2. Remove the rear frame cover. See “Rear frame cover removal” on page 4-38 . 3. Remove the right cover. See “Right cover removal” on page 4-39 . 4. Check the connector at JOPT1 on the system board for proper connection, the cable for pinch points, and the cable or connector for any other damage.   Is the cable damaged?	Replace the option cable. See “Option cable removal” on page 4-115 .	Go to step 4.

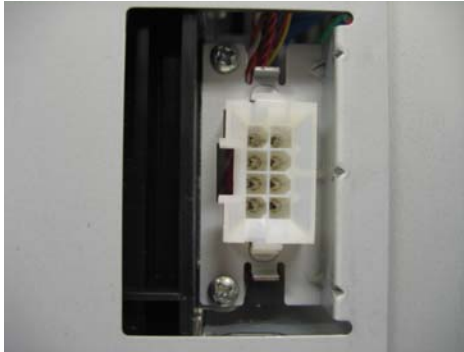
Step	Questions / actions	Yes	No
4	<p>Carefully lift the printer off the option, and lay the printer on its back.</p> <p>Check the option connector for damage.</p>  <p>Is the connector damaged?</p>	<p>Replace the option cable. See “Option cable removal” on page 4-115.</p>	<p>Go to step 5.</p>
5	<p>Is tray 5 a high-capacity input option (2,000-sheet feeder)?</p>	<p>Go to step 7.</p>	<p>Go to step 6.</p>
6	<p>Replace the complete tray 5 option.</p> <p>Does the error clear?</p>	<p>Problem resolved.</p>	<p>Replace the system board. See “System board removal” on page 4-148.</p>
7	<p>Replace the high-capacity input tray (2,000-sheet feeder)?</p>	<p>Problem resolved.</p>	<p>Replace the system board. See “System board removal” on page 4-148.</p>

245.10—Paper Jam service check

Step	Questions / actions	Yes	No
1	<ol style="list-style-type: none"> 1. Bring the printer up in Diagnostics Menu (turn the multifunction printer off, press and hold 3 and 6, turn the MFP on, and then release the buttons when the progress bar displays). 2. Touch PRINT TESTS. 3. Select a tray below tray 5. 4. Touch Single. <p>Did the page feed correctly?</p>	<p>Problem resolved.</p>	<p>Replace the complete tray 5 option.</p>

245.17—Paper Jam service check

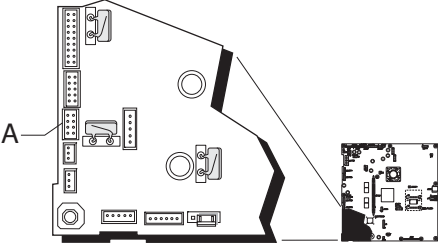
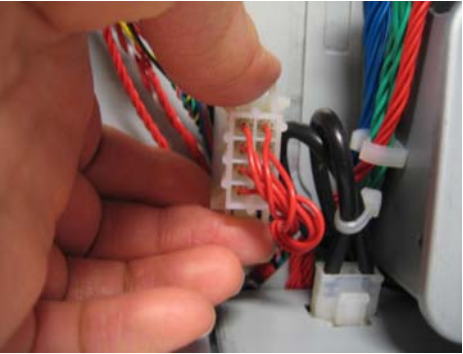
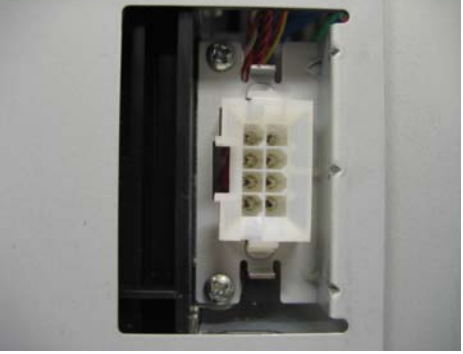
Step	Questions / actions	Yes	No
1	Has paper been fed from an input option before?	Go to step 4.	Go to step 2.
2	<p>Turn the printer off, and then remove the rear frame cover. See “Rear frame cover removal” on page 4-38. Remove the right cover. See “Right cover removal” on page 4-39.</p> <p>Check the cable in connector JOPT1 (A) for proper connection to the system board, cable pinch points, and any other damage to the cable or connector.</p>   <p>Is the cable damaged?</p>	Replace the option cable. See “Option cable removal” on page 4-115 .	Go to step 3.
3	<p>Carefully lift the printer off the option, and lay the printer on its back. Check the option connector for damage.</p>  <p>Is the option cable connector or cable damaged?</p>	Replace the option cable. See “Option cable removal” on page 4-115 .	Go to step 4.

Step	Questions / actions	Yes	No
4	Is tray 5 an high-capacity input tray (HCIT)?	Replace the HCIT top plate. See “Top plate assembly removal” on page 4-264.	Replace the complete tray 5 option.

245.29—Paper Jam service check

Step	Questions / actions	Yes	No
1	<ol style="list-style-type: none"> 1. Bring the printer up in Diagnostics Menu (turn the multifunction printer off, press and hold 3 and 6, turn the MFP on, and then release the buttons when the progress bar displays). 2. Select PRINT TESTS. 3. Select Tray 5. 4. Select Single. Did the page feed correctly?	Problem resolved.	Go to step 2.
2	Is tray 5 a high-capacity input tray (2,000-sheet feeder)?	Replace the HCIT elevator-up sensor. See “HCIT elevator motor with sensor removal” on page 4-257.	Replace the complete tray 5 option.



290.01, 290.02—Scanner ADF pickup/feed jam service check

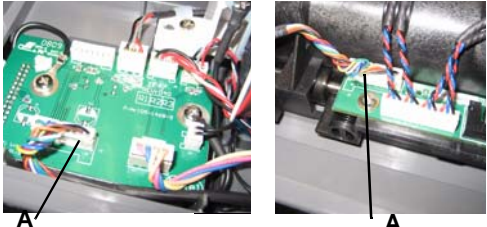

Step	Questions / actions	Yes	No
1	Load paper in the ADF input tray. Touch Copy . Do you hear the ADF gear train motor running?	Go to step 2.	Replace the ADF motor gear train assembly. See “ADF motor gear train removal” on page 4-219
2	Open the ADF cover.  Is the skew flag (A) damaged?	Replace the ADF case assembly. See “ADF case assembly removal” on page 4-213.	Go to step 3.

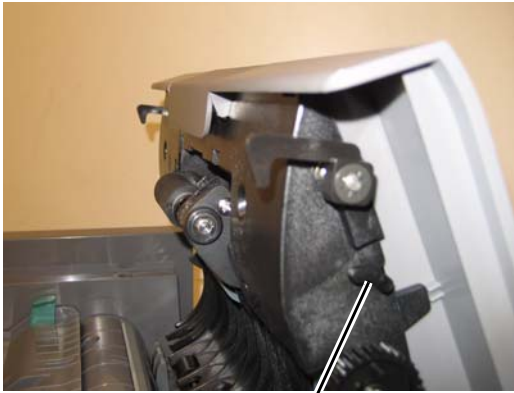
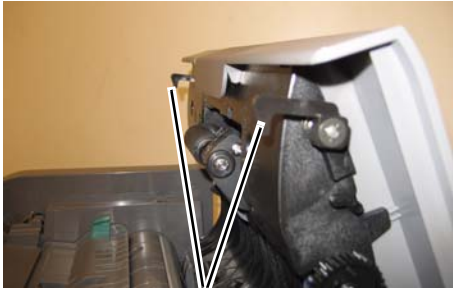
Step	Questions / actions	Yes	No
3	<p>1. Remove the ADF motor side cover. See “ADF motor side cover removal” on page 4-194.</p> <p>2. Remove the ADF front side cover. See “ADF front side cover removal” on page 4-192 and</p>  <p>Is the cable (A) connected correctly?</p>	<p>Replace the front case assembly. See “ADF case assembly removal” on page 4-213.</p>	<p>Reseat the cable.</p>

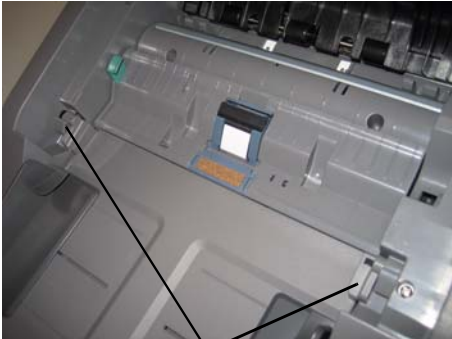
292.00—Scanner ADF cover open jam service check

Step	Questions / actions	Yes	No
1	<p>Open the ADF cover. Check the ADF cover sensor flag (A) for damage.</p>  <p>Is the flag damaged?</p>	<p>Replace the flag. See “ADF closed cover flag removal” on page 4-215.</p>	<p>Go to step 2.</p>
2	<p>Check the ADF top cover latch.</p>  <p>Are the latches damaged?</p>	<p>Replace the ADF front cover assembly. See “Scanner front cover removal” on page 4-205</p>	<p>Go to step 3.</p>

Step	Questions / actions	Yes	No
3	<p>Check the covers where the ADF top cover latches hook.</p>  <p style="text-align: center;">A</p> <p>Are either cover hooks damaged?</p>	<p>Replace the damaged cover. For the ADF motor side cover, see “ADF motor side cover removal” on page 4-194.</p> <p>For the ADF front side cover, see “ADF front side cover removal” on page 4-192.</p>	Go to step 4.
4	<ol style="list-style-type: none"> 1. Remove the ADF front cover. See “ADF front cover removal” on page 4-190. 2. Close the ADF. 3. Turn on the MPF. 4. Check the voltage on the ADF cover sensor. <p>Does the voltage measure 5 V?</p>	Go to step 5.	Replace the ADF front assembly. See “ADF front cover removal” on page 4-190.
5	<p>Check for proper ADF grounding.</p> <ol style="list-style-type: none"> 1. Remove the ADF upper case cover. See “ADF upper case cover removal” on page 4-197. 2. With an ohm meter, check resistance between the feed shaft and the skew shaft.  <p>Does resistance measure 0 ohms?</p>	Go to step 6.	Replace the steel discharge brush. See “ESD brush removal” on page 4-230.

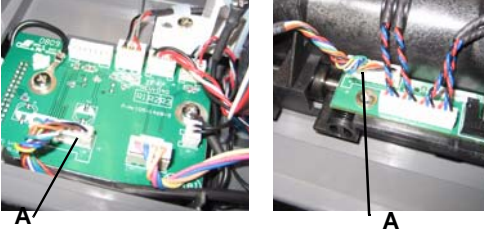
Step	Questions / actions	Yes	No
6	<p>Tighten the screws on the grounding cable.</p>  <p>Measure the resistance between the feed shaft and the ADF upper case cover metal bar.</p>  <p>Does the resistance measure 0 ohms?</p>	Go to step 7.	Replace the grounding cable.
7	<p>Check the cabling (ADF front assembly to scanner MDC card).</p>  <p>Is the cable damaged?</p>	Go to step 8.	Replace the cable.

Step	Questions / actions	Yes	No
8	<p>Check the cabling (scanner MDC card to scanner UICC card).</p>  <p style="text-align: center;">A</p> <p>Is the cable damaged?</p>	<p>Replace the UICC card. See “UICC card removal” on page 4-174</p>	<p>Replace the cable. See “UICC cable removal” on page 4-178.</p>

293.02—Flatbed cover open jam service check

Step	Questions / actions	Yes	No
1	<p>Replace the scanner ICC card. See “Scanner ICC card removal” on page 4-244.</p> <p>Did the error clear?</p>	<p>Problem resolved.</p>	<p>Replace the ADF. See “ADF removal (entire)” on page 4-210.</p>

842.xx—Scanner Failure—Communication failure service check

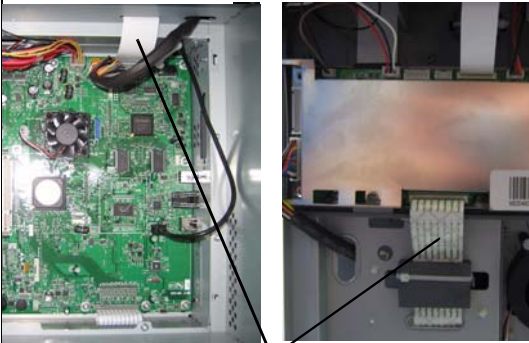
Step	Questions / actions	Yes	No
1	<ol style="list-style-type: none"> 1. Check the scanner flex cable from the scanner MDC card to the system board. 2. Remove the left cover. See “Left cover removal” on page 4-23. 3. Remove the rear frame cover. See “Rear frame cover removal” on page 4-38.  <p style="text-align: center;">A</p> <p>Are both ends of the cable (A) seated?</p>	<p>Go to step 2.</p>	<p>Reseat the scanner flex cable.</p>
2	<p>Is the scanner flex cable damaged?</p>	<p>Replace the scanner flex cable.</p>	<p>Go to step 3.</p>

Step	Questions / actions	Yes	No
3	Replace the scanner MDC card. See “Scanner ICC cable removal” on page 4-245. Is the problem fixed?	Problem resolved.	Replace the system board. See “System board removal” on page 4-148.

843.00—Scanner Failure—Carriage failed to move service check

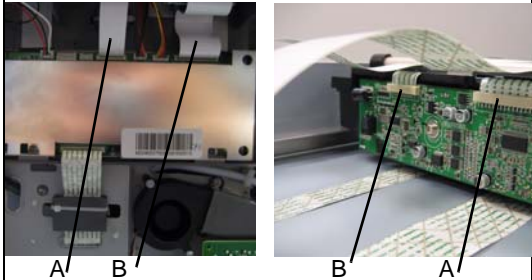
Step	Questions / actions	Yes	No
1	Check the flatbed motor cables. Remove the flatbed with glass cover. See “Flatbed with glass cover removal” on page 4-201.  Are either end of the cables (A, B) loose?	Reseat the flatbed motor cable.	Replace the flatbed scanner. See “Flatbed scanner removal” on page 4-240

843.01, 843.02—Scanner Failure service check

Step	Questions / actions	Yes	No
1	Check the ADF cable. 1. Remove the left cover. See “Left cover removal” on page 4-23. 2. Remove the scanner rear cover. See “Scanner rear cover removal” on page 4-207.  Is the cable (A) damaged?	Replace the ADF cable.	Replace the ADF. See “ADF removal (entire)” on page 4-210.

844.xx—Scanner Error—scan module output level error service check

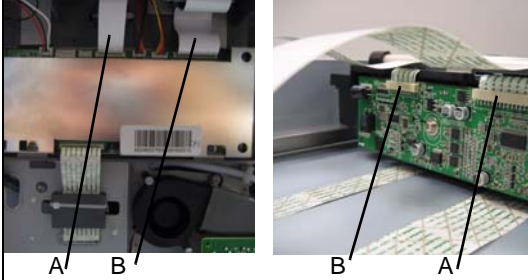
Step	Questions / actions	Yes	No
1	Check the flatbed lamp. Is the lamp on brightly?	Go to step 2.	Replace the flatbed lamp. See “Flatbed CCD lamp assembly removal” on page 4-232.
2	Remove the left cover. See “Left cover removal” on page 4-23.  Are the cables (A and B) securely connected?	Go to step 3.	Reseat the flatbed CCD cable.
3	Are the cables damaged?	Replace the flatbed scanner. See “Flatbed scanner removal” on page 4-240	Replace the flatbed CC carrier module. See “Flatbed CCD carrier module removal” on page 4-235.

845.xx—Scanner Failure service check

Scan module cable failure or SCC card failure. CCD channel failure.

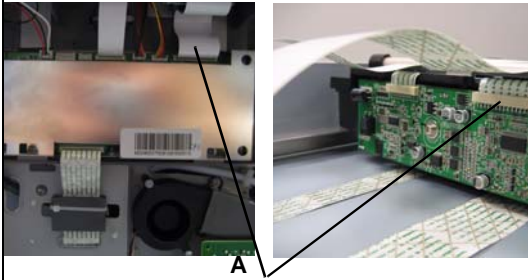
Step	Questions / actions	Yes	No
1	Check flatbed CCD cable (A). Remove the flatbed with glass cover. See “Flatbed with glass cover removal” on page 4-201.  Is the cable loose?	Reseat the flatbed CCD cable.	Replace the flatbed scanner. See “Flatbed scanner removal” on page 4-240.
2	Is the flatbed CCD cable damaged?	Replace the flatbed CCD cable.	Replace the scanner MDC card. See “Scanner ICC cable removal” on page 4-245.

846.xx—Front calibration strip error service check

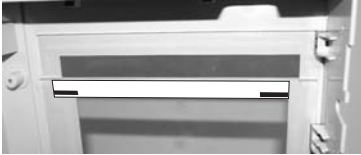
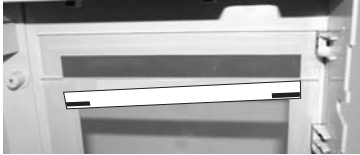
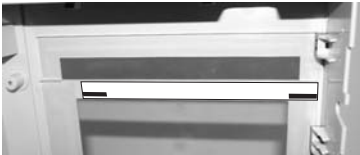
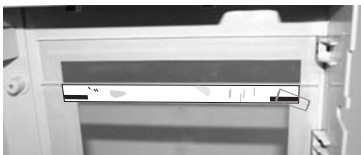
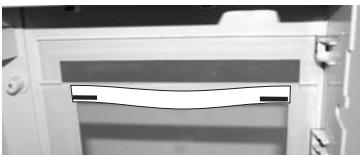
Step	Questions / actions	Yes	No
1	<p>Remove the flatbed with glass cover See “Flatbed with glass cover removal” on page 4-201.</p> <p>Is flatbed calibration strip properly attached to the flatbed with glass cover?</p> <div style="display: flex; justify-content: space-around; align-items: flex-start;"> <div style="text-align: center;">  Shifted left </div> <div style="text-align: center;">  Skewed </div> </div> <div style="display: flex; justify-content: space-around; align-items: flex-start;"> <div style="text-align: center;">  Shifted right </div> <div style="text-align: center;">  Dirty </div> </div> <div style="text-align: center; margin-top: 10px;">  Bowed </div>		

900.05—Transfer module error service check

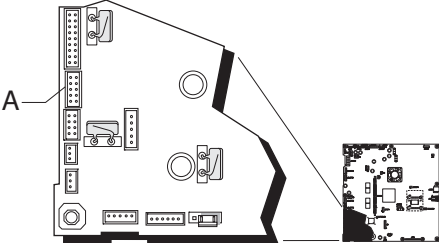
Step	Questions / actions	Yes	No
1	<p>Turn the printer off, and then remove the rear frame cover. See “Rear frame cover removal” on page 4-38.</p> <p>Check the transport cable in connector JTSP1 for proper connection to the system board, cable pinch points, and any other damage to the cable or connector.</p> <div style="text-align: center;">  </div> <p>Is the cable damaged?</p>	<p>Replace the transport cable. See “Transport cable removal” on page 4-170.</p>	<p>Go to step 2.</p>
2	<p>Replace the transfer module.</p> <p>Does the error clear?</p>	<p>Problem resolved.</p>	<p>Replace the system board. See “System board removal” on page 4-148.</p>

902.59—Engine software error, NVRAM MGR problem

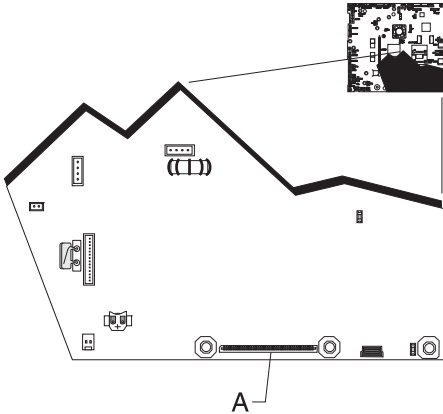
Step	Questions / actions	Yes	No
1	Has the system board been recently replaced?	Replace with a new printhead that has never been used before. See “System board removal” on page 4-148.	Go to step 2.
2	Has the transfer module been recently replaced?	Replace with a new transfer module. See “Transfer module removal” on page 4-168.	Go to step 3.
3	<p>Make sure the printhead is connected to connector JPH1</p> <p>Remove the rear frame cover. See “Rear frame cover removal” on page 4-38.</p>  <p>Is the printhead connected correctly?</p>	Go to step 4.	Reseat the connector.
4	Has the printhead been recently replaced?	Replace with a new part. See “Printhead removal, installation, and adjustment” on page 4-128.	Contact the next level of support.

920.03, 920.25—Transfer Module Missing error service check

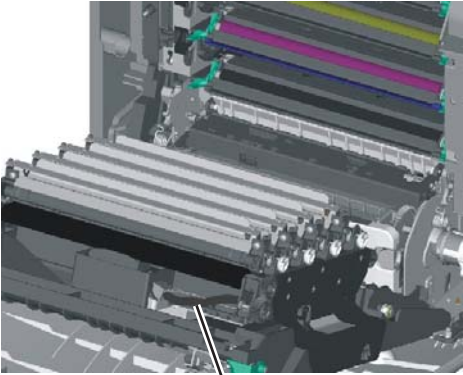
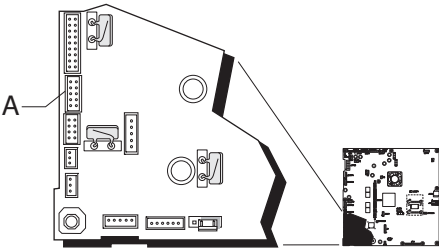
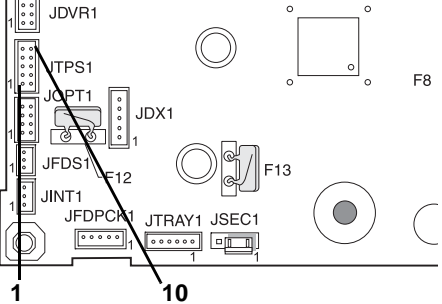
Step	Questions / actions	Yes	No
1	<p>Open the front access door. Reseat the transport cable.</p>  <p style="text-align: center;">A</p> <p>Does the error clear?</p>	Problem resolved.	Go to step 2.
2	<p>Turn the printer off, and then remove the rear frame cover. See “Rear frame cover removal” on page 4-38.</p> <p>Reseat the transport cable in connector JTPS1 (A).</p>  <p style="text-align: center;">A</p> <p>Does the error clear?</p>	Problem resolved.	Go to step 3.
3	<p>Check the transport cable in connector JTPS1 for pinch points and for any other damage to the cable or connector.</p> <p>Is the cable damaged?</p>	Replace the transport cable. See “Transport cable removal” on page 4-170.	Go to step 4.
4	<p>Check the continuity at JTPS1, pins 1–10).</p>  <p style="text-align: center;">1 10</p> <p>Is there continuity?</p>	Go to step 5.	Replace the cartridge motor1/fuser motor cable. See “Cartridge motor 1/ fuser cable removal” on page 4-55.

Step	Questions / actions	Yes	No
5	Replace the transport belt assembly. See “Transfer module removal” on page 4-168. Does the error clear?	Problem resolved.	Replace the system board. See “System board removal” on page 4-148.

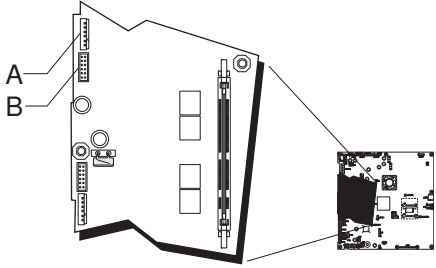
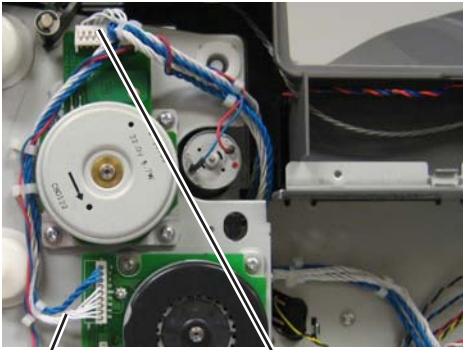

920.04—POST error service check

Step	Questions / actions	Yes	No
1	Turn the printer off, and then remove the rear frame cover. See “Rear frame cover removal” on page 4-38. Reseat the cables in connectors JCARTP1 and JCARTS1.  Does the error clear?	Problem resolved.	Go to step 2.
2	Check the cartridge motor 1/fuser cable in connector JCARTP1 and JCARTS1 for pinch points and the cable or connector for any other damage. Is the cable damaged?	Replace the cartridge motor1/fuser cable. See “Cartridge motor 1/fuser cable removal” on page 4-55.	Go to step 4.
3	Remove the right cover. See “Right cover removal” on page 4-39. Check the cartridge motor 1/fuser motor cable (A) for proper connection to the EP drive assembly, pinch point for the cable, and damage to the cable or connector  Is either cable damaged?	Replace the cartridge motor1/fuser motor cable. See “Cartridge motor 1/fuser cable removal” on page 4-55.	Go to step 4.
4	Replace the EP drive assembly. See “Electrophotographic (EP) drive assembly removal” on page 4-70. Does the error clear?	Problem resolved.	Replace the system board. See “System board removal” on page 4-148.

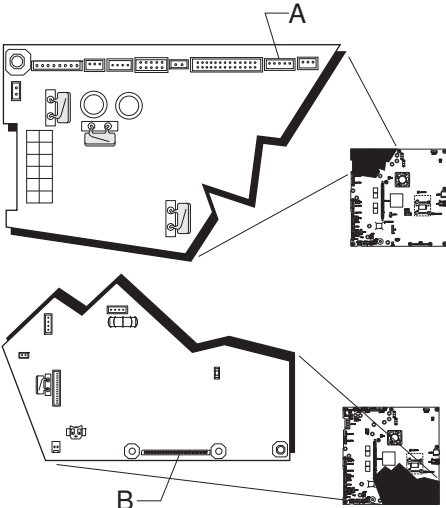
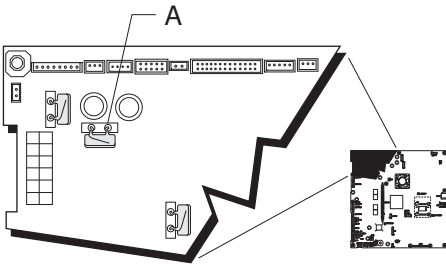

920.05—POST—printhead motor not connected error service check

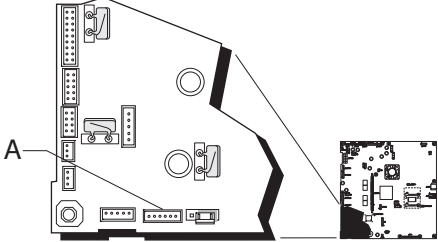
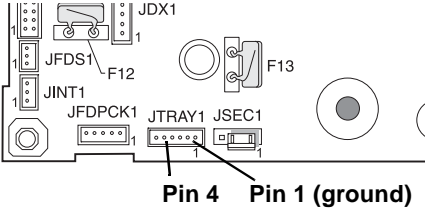
Step	Questions / actions	Yes	No
1	<p>Turn the printer off, and then remove the rear frame cover. See “Rear frame cover removal” on page 4-38.</p> <p>Reseat the cables in connectors JMIRR1 (A) and JPH1 (B).</p>  <p>Does the error clear?</p>	Problem resolved.	Go to step 2.
2	<p>Check the cables in connectors JMIRR1 and JPH1 for pinch points and any other damage to the cables or connectors.</p> <p>Is the cable damaged?</p>	Replace the printhead. See “Printhead removal, installation, and adjustment” on page 4-128.	Go to step 3.
3	<p>Measure the resistance across fuse F6 on the system board.</p>  <p>Is the fuse blown?</p>	Replace the system board. See “System board removal” on page 4-148.	Go to step 4.
4	<p>Perform the printhead verification to check whether the new printhead solves the problem. See “Printhead verification” on page 3-52.</p> <p>Perform the Mirror Motor Test. See “Mirror Motor Test” on page 3-22.</p> <p>Did the mirror motor pass the test?</p>	Replace the printhead. See “Printhead removal, installation, and adjustment” on page 4-128.	Replace the system board. See “System board removal” on page 4-148.

920.07—POST error service check

Step	Questions / actions	Yes	No
1	<p>Turn the printer off, and then remove the rear frame cover. See “Rear frame cover removal” on page 4-38.</p> <p>Reseat the cable in connector JTRAY1.</p>  <p>Does the error clear?</p>	<p>Problem resolved.</p>	<p>Go to step 2.</p>
2	<p>Check the cable in connector JTRAY1 for pinch points and the cable or connector for any other damage.</p> <p>Is the cable damaged?</p>	<p>Replace the paper pick mechanism. See “Paper pick mechanism assembly removal” on page 4-117.</p>	<p>Go to step 3.</p>
3	<p>Place a voltmeter between JTRAY1 pin 4 and ground (pin 1).</p>  <p>Does the meter read +5 V dc?</p>	<p>Go to step 4</p>	<p>Replace the system board. See “System board removal” on page 4-148.</p>
4	<ol style="list-style-type: none"> 1. Disconnect the cable in JTRAY1, and connect the cable from the new paper pick mechanism. 2. Bring the printer up in the Diagnostics menu (turn off the printer, press and hold 3 and 6, turn on the printer.) 3. Touch Sensor Tests. 4. Touch Dynamic Sensors. 5. Touch Narrow Media. 6. Activate the narrow media sensor.  <p>Did the narrow media sensor change from Closed to Open on the touchscreen?</p>	<p>Remove the paper pick mechanism. See “Paper pick mechanism assembly removal” on page 4-117.</p>	<p>Replace the system board. See “System board removal” on page 4-148.</p>

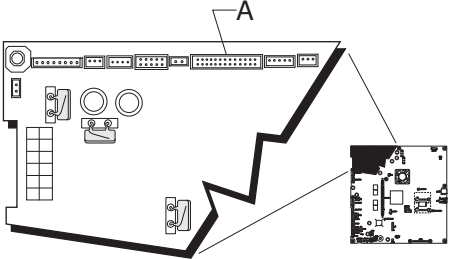
920.09—POST—Four toner sensor not connected error service check

Step	Questions / actions	Yes	No
1	<p>Turn the printer off, and then remove the rear frame cover. See “Rear frame cover removal” on page 4-38.</p> <p>Reseat the cable in connector JHVPS1.</p>  <p>Does the error clear?</p>	Problem resolved.	Go to step 2.
2	<p>Check the HVPS cable in connector JHVPS1 for pinch points and any other damage to the cable or connector.</p> <p>Is the cable damaged?</p>	Replace the HVPS cable. See “High-voltage power supply (HVPS) cable removal” on page 4-102.	Go to step 3.
3	<p>Remove the left cover. See “Left cover removal” on page 4-23. Check all the toner level sensor cables connected to the rear of the HVPS.</p>  <p>Are any of the cables damaged?</p>	Replace the damaged cable.	Go to step 4.
4	<p>Replace the HVPS board. See “High-voltage power supply (HVPS) removal” on page 4-100.</p> <p>Does the error clear.</p>	Problem resolved.	Replace the system board. See “System board removal” on page 4-148.

920.10—POST—Three toner sensors not connected error service check

Step	Questions / actions	Yes	No
1	<p>Check all toner level sensor cables (A) connected to the rear of the HVPS.</p>  <p>A</p> <p>Are any of the cables damaged?</p>	<p>If one or two of the toner level sensor are damaged:</p> <ul style="list-style-type: none"> • Disconnect the sensor(s), and • Go to step 2. <p>If two toner level sensors are damaged, replace the damaged sensor. See “Toner level sensor removal” on page 4-157.</p>	Go to step 2.
2	<p>Disconnect one of the toner level sensors, and POR the MFP. See “Toner level sensor removal” on page 4-157.</p> <p>Does the 910.10 error occur again?</p>	<p>Then this is one of the three bad toner level sensors. Continue disconnecting the toner level sensors until three sensors are disconnected and the 920.10 error occurs.</p> <p>Replace the toner level sensors that are disconnected. See “Toner level sensor removal” on page 4-157.</p>	Repeat this step for the other toner level sensors until the 920.10 error occurs.

920.11—POST—Two toner sensors not connected error service check

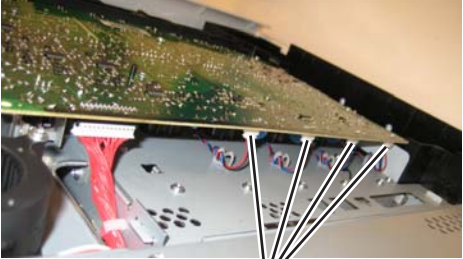
Step	Questions / actions	Yes	No
1	<p>Check all toner level sensor cables connected to the rear of the HVPS.</p>  <p style="text-align: center;">A</p> <p>Are any of the cables damaged?</p>	<p>If only one toner level sensor is damaged:</p> <ul style="list-style-type: none"> • Disconnect the sensor. • Go to step 2. <p>If two toner level sensors are damaged, replace the damaged sensors. See “Toner level sensor removal” on page 4-157.</p>	Go to step 2.
2	<p>Disconnect one of the toner level sensors, and POR the printer. See “Toner level sensor removal” on page 4-157.</p> <p>Does the 920.11 error occur again?</p>	<p>If the error recurs, then this sensor is one of the bad sensors. Continue disconnecting the toner level sensors until two sensors are disconnected and the 920.11 error occurs.</p> <p>Replace the toner level sensors that are disconnected. See “Toner level sensor removal” on page 4-157.</p>	Repeat this step for the other toner level sensors until the 920.11.

920.12—POST—One sensor not connected error service check

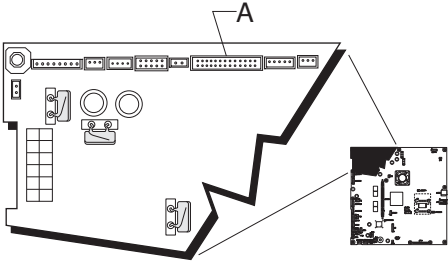

Step	Questions / actions	Yes	No
1	Check all toner level sensor cables connected to the rear of the HVPS. Are any of the cables damaged?	Replace the damaged sensor. See “Toner level sensor removal” on page 4-157.	Go to step 2.
2	Disconnect the cable in JHVPS from the system board and HVPS. Check for the following continuity.  Is continuity present?	Go to step 3.	Replace the HVPS cable. See “High-voltage power supply (HVPS) cable removal” on page 4-102.
3	Disconnect one of the toner level sensors, and POR the printer. See “Toner level sensor removal” on page 4-157. Does the 920.12 error occur again?	Replace the toner level sensor that is disconnected. See “Toner level sensor removal” on page 4-157.	Repeat the step for the other toner level sensors until the 920.12 error occurs.

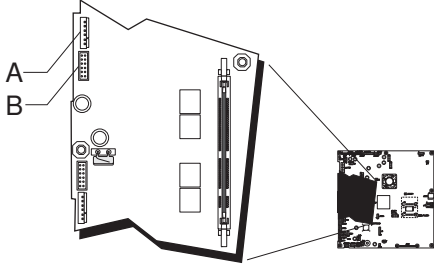
920.13—POST error service check

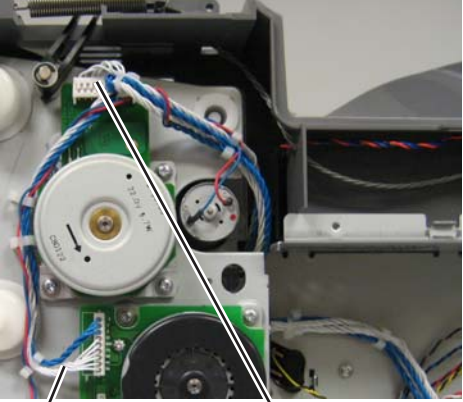
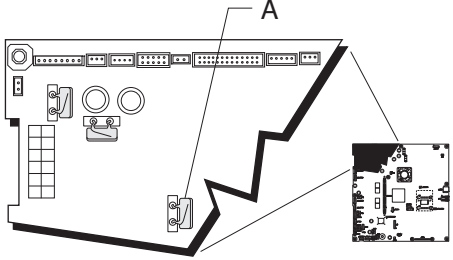
Step	Questions / actions	Yes	No
1	Turn the printer off, and then remove the rear frame cover. See “Rear frame cover removal” on page 4-38. Reseat the cables in connectors JCARTP1 (A) and JCARTS1 (B).  Does the error clear?	Problem resolved.	Go to step 2.
2	Check the cables in connectors JCARTP1 and JCARTS1 for pinch points and any other damage to the cables or connectors. Is the cable damaged?	Replace the cartridge motor 1/fuser cable. See “Cartridge motor 1/fuser cable removal” on page 4-55.	Go to step 3.

Step	Questions / actions	Yes	No
<p>3</p>	<p>Remove the right cover. See “Right cover removal” on page 4-39.</p> <p>Check for the cartridge 1/fuser motor cable for proper connection to the EP drive assembly, pinch points for the cable, or any other damage to the cable or connector.</p>  <p>Is either cable (A) damaged?</p>	<p>Replace the cartridge motor 1/fuser cable. See “Cartridge motor 1/fuser cable removal” on page 4-55.</p>	<p>Go to step 4.</p>
<p>4</p>	<p>Measure the resistance across fuse F7 on the system board.</p>  <p>Is the fuse blown?</p>	<p>Replace the system board. See “System board removal” on page 4-148.</p>	<p>Replace the EP drive assembly. See “Electrophotographic (EP) drive assembly removal” on page 4-70.</p>

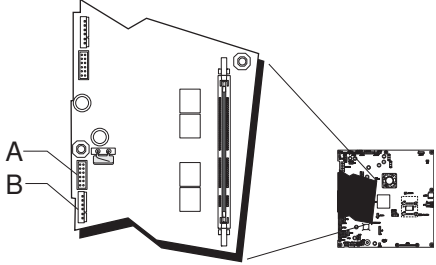
920.14—POST—Cartridge motor 2 not connected error service check

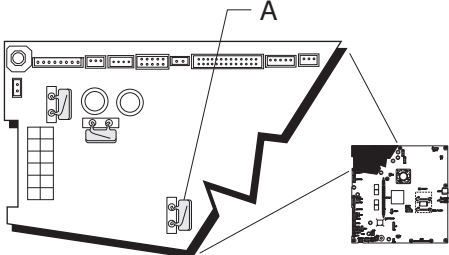
Step	Questions / actions	Yes	No
1	<p>Turn the printer off, and then remove the rear frame cover. See “Rear frame cover removal” on page 4-38.</p> <p>Reseat the cables in connector JCARTP2 (A) and JCARTS2 (B).</p>  <p>Does the error clear?</p>	Problem resolved.	Go to step 2.
2	<p>Check the cable in connector JCARTP2 and JCARTS2 for pinch points and any other damage to the cable or connector.</p> <p>Are the cables damaged?</p>	Replace the cartridge motor 2/3 cable. See “Cartridge motor 2/3 cable removal” on page 4-57.	Go to step 3.
3	<p>Remove the right cover. See “Right cover removal” on page 4-39.</p> <p>Check the cartridge motor 2/3 cable (A) for the proper connection to the EP drive assembly, pinch point for the cable, or damage to the cable or connectors.</p>  <p>Is either cable (A) damaged?</p>	Replace the cartridge motor 2/3 cable. See “Cartridge motor 2/3 cable removal” on page 4-57.	Go to step 4.
4	<p>Measure the resistance across the fuse F7 (A) on the system board.</p>  <p>Is the fuse blown?</p>	Replace system board. See “System board removal” on page 4-148.	Replace the EP drive assembly. See “Electrophotographic (EP) drive assembly removal” on page 4-70.

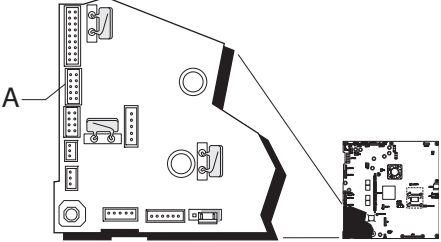
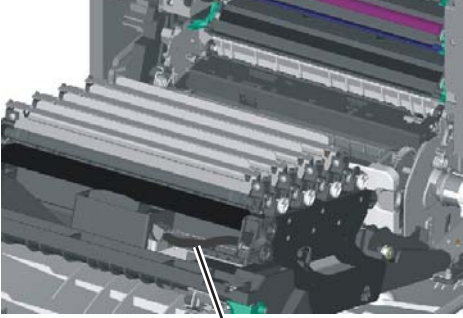

920.15, 920.20—POST—Bad transfer module NVRAM data error service check

Step	Questions / actions	Yes	No
1	<p>Turn the printer off, and then remove the rear frame cover. See “Rear frame cover removal” on page 4-38.</p> <p>Reseat the transport cable in connector JTPS1 (A)</p>  <p>Does the error clear?</p>	Problem resolved.	Go to step 2.
2	<p>Check the transport cable in connector JTPS1 for pinch points and for any other damage to the cable or connector.</p> <p>Is the cable damaged?</p>	Replace the transport cable. See “Transport cable removal” on page 4-170.	Go to step 3.
3	<p>Lower the front access cover. Check the transport cable for pinch points and any other cable damage.</p>  <p>Is the cable damaged?</p>	Replace the transport cable. See “Transport cable removal” on page 4-156.	Go to step 4.
4	<p>Replace the transfer module. See “Transfer module removal” on page 4-168.</p> <p>Does the error clear?</p>	Problem resolved.	Replace the system board. See “System board removal” on page 4-148.

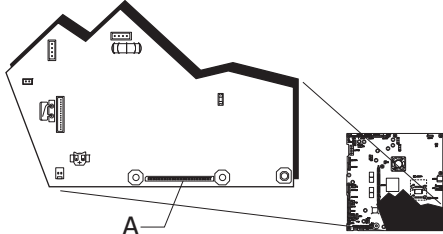
920.16—POST error service check

Step	Questions / actions	Yes	No
1	<p>Turn the printer off, and then remove the rear frame cover. See “Rear frame cover removal” on page 4-38.</p> <p>Reseat the large printhead cable in connector JPH1.</p>  <p>Does the error clear?</p>	Problem resolved.	Go to step 2.
2	<p>Check the cable in connector JPH1 for pinch points and any other damage to the cable or connector.</p> <p>Is the cable damaged?</p>	Replace the printhead. See “Printhead removal, installation, and adjustment” on page 4-128.	Go to step 3.
3	<p>Perform the printhead verification to check whether the printhead replacement fixes the problem. See “Printhead verification” on page 3-52</p> <p>Did the printhead motor pass the test?</p>	Replace the printhead. See “Printhead removal, installation, and adjustment” on page 4-128.	Replace the system board. See “System board removal” on page 4-148.

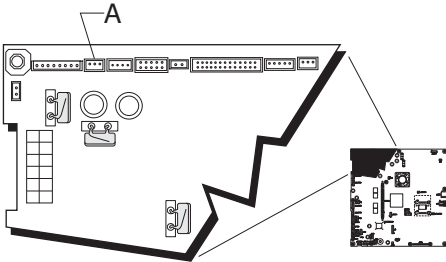
920.17—POST error service check



Step	Questions / actions	Yes	No
1	<p>Turn the printer off, and then remove the rear frame cover. See “Rear frame cover removal” on page 4-38.</p> <p>Reseat the bin full sensor cable in connector JBIN1.</p>  <p>Does the error clear?</p>	Problem resolved.	Go to step 2.
2	<p>Check the bin full sensor cable in connector JBIN1 for pinch points and any other damage to the cable or connector.</p> <p>Is the cable damaged?</p>	Replace the bin full sensor with cable. See “Bin full sensor assembly removal” on page 4-52.	Go to step 3.
3	<ol style="list-style-type: none"> 1. Disconnect the cable in JBIN1 connector. 2. Connect the new bin full sensor flag connector in the JBIN1 connector. 3. Bring the printer up in the Diagnostics menu (turn off the printer, press and hold 3 and 6, turn on the printer.) 4. Touch SENSOR TESTS. 5. Touch Dynamic Sensors. 6. Touch Other Sensors. 7. Touch Bin Full. 8. Activate the new bin full sensor by pressing on the flag, as shown.  <p>Did the bin full sensor change from Open to Closed on the touchscreen?</p>	Replace the bin full sensor and cable. See “Bin full sensor assembly removal” on page 4-52.	Replace the system board. See “System board removal” on page 4-148.

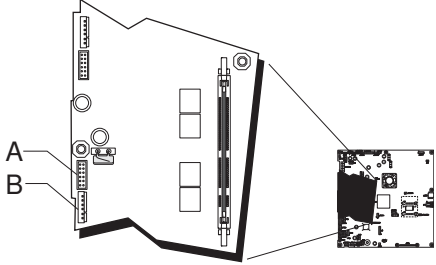
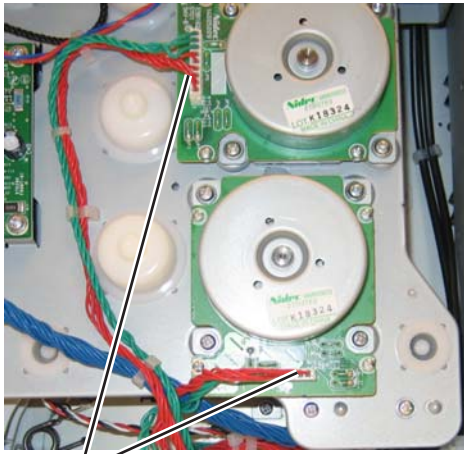

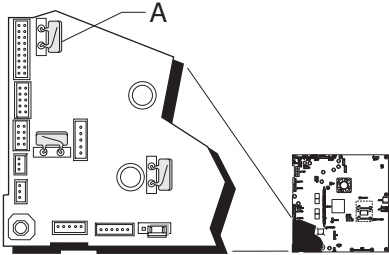
920.18—POST—Cartridge motor 3 not connected error service check

Step	Questions / actions	Yes	No
1	<p>Turn the printer off and remove the rear frame cover. See “Rear frame cover removal” on page 4-38.</p> <p>Reseat the cables in connectors JCARTP2 and JCARTS2.</p>  <p>Does the error clear?</p>	Problem resolved.	Go to step 2.
2	<p>Remove the right cover. See “Right cover removal” on page 4-39.</p> <p>Check the cartridge motor 2/3 cables in connectors JCARTP2 and JCARTS2 for pinch points and any other damage to the cables or the connectors.</p> <p>Are the cables damaged?</p>	Replace the cartridge motor 2/3 cable. See “Cartridge motor 2/3 cable removal” on page 4-57.	Go to step 3.
3	<p>Remove the right cover. Check the cartridge motor 2/3 cable for proper connections to the EP drive assembly, pinch points for the cable, and damage to the cable or connector.</p>  <p>Is either cable damaged?</p>	Replace the cartridge motor 2/3 cable. See “Cartridge motor 2/3 cable removal” on page 4-57.	Go to step 4.

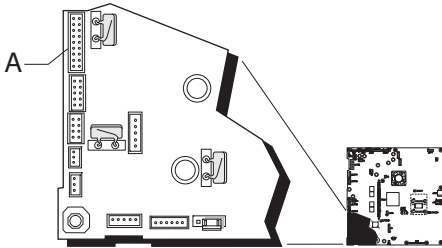
Step	Questions / actions	Yes	No
<p>4</p>	<p>Measure the resistance across the fuse F10 on the system board.</p>  <p>Is the fuse blown?</p>	<p>Replace the system board. See “System board removal” on page 4-148.</p>	<p>Replace the EP drive assembly. See “Electrophotographic (EP) drive assembly removal” on page 4-70.</p>

920.19—POST—Transfer module stepper motor not connected error service check

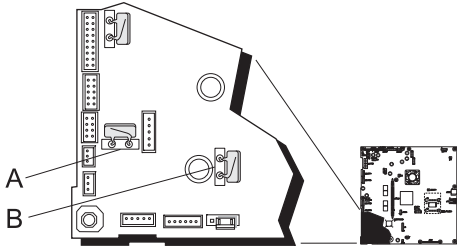
Step	Questions / actions	Yes	No
<p>1</p>	<p>Turn the printer off, and then remove the rear frame cover. See “Rear frame cover removal” on page 4-38.</p> <p>Reseat the motor driver cable in connector JDVR1.</p>  <p>Does the error clear?</p>	<p>Problem resolved.</p>	<p>Go to step 2.</p>
<p>2</p>	<p>Check the motor driver cable in connector JDVR1 for pinch points and any other damage to the cable or connector. Check both the system board end and the motor driver end.</p>  <p>Is the cable (A) damaged?</p>	<p>Replace the motor driver cable. See “Motor driver cable removal” on page 4-106.</p>	<p>Go to step 3.</p>

Step	Questions / actions	Yes	No
3	<p>Measure the resistance across fuses F12 and F13 on the system board.</p>  <p>Is either fuse blown?</p>	<p>Replace the system board. See “System board removal” on page 4-148.</p>	<p>Go to step 4.</p>
4	<p>Check the transport motor cable for pinch points and any other damage to the cable or connector. Check both ends of the cable.</p> <p>Is the cable damaged?</p>	<p>Replace the transport motor cable. See “Transport cable removal” on page 4-170.</p>	<p>Go to step 5.</p>
5	<p>Visually inspect the motor driver card.</p>  <p>Is the motor driver card damaged?</p>	<p>Replace the motor driver card. See “Motor driver card removal” on page 4-107.</p>	<p>Go to step 6.</p>
6	<p>Replace the EP drive assembly. See “Electrophotographic (EP) drive assembly removal” on page 4-70.</p>	<p>Problem resolved.</p>	<p>Replace the system board. See “System board removal” on page 4-148.</p>

920.21—POST error service check

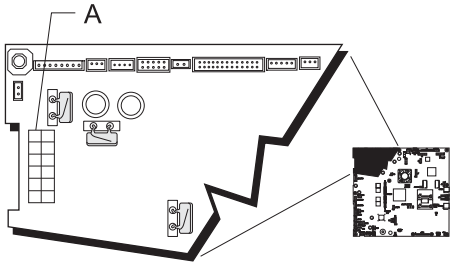

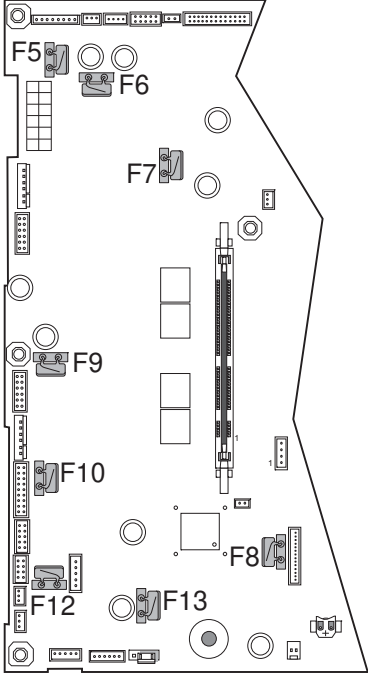
Step	Questions / actions	Yes	No
1	<p>Check the input voltage switch on the back of the low-voltage power supply (LVPS). Some power supplies do not have the switch, and automatically switch.</p> <p>Note: Some LVPS FRUs do not have a switch, and are switch automatically. If your FRU does not have this switch, go to step 2.</p>  <p>Is the voltage level (115/230) properly set?</p>	Go to step 2.	Set the switch for the proper country voltage.
2	<p>Turn the printer off, and then remove the rear frame cover. See “Rear frame cover removal” on page 4-38.</p> <p>Reseat the cable in connector JLVP2.</p>  <p>Does the error clear?</p>	Problem resolved.	Go to step 3.
3	<p>Check the cable JLVP2 for pinch points and any other damage to the cable or connector.</p> <p>Is the cable damaged?</p>	Replace the low-voltage power supply. See “Low-voltage power supply (LVPS) removal” on page 4-104 .	Go to step 4.

Step	Questions / actions	Yes	No
4	<p>Measure the resistance across fuses F5, F6, F7, F9, F10, F12, and F13 on the system board.</p>  <p>Are any of the fuses blown?</p>	<p>Replace the system board. See “System board removal” on page 4-148.</p>	<p>Replace the low-voltage power supply. See “Low-voltage power supply (LVPS) removal” on page 4-104.</p>

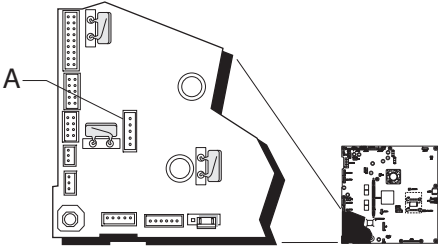
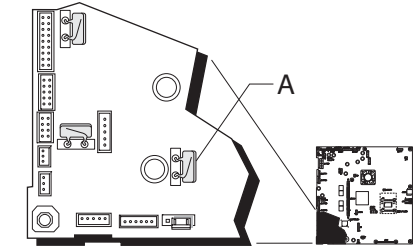
920.23—POST error service check

Step	Questions / actions	Yes	No
1	<p>Turn the printer off, and then remove the rear frame cover. See “Rear frame cover removal” on page 4-38.</p> <p>Reseat the cable in connector JDX1.</p>  <p>Does the error clear?</p>	Problem resolved.	Go to step 2.
2	<p>Check the MPF/duplex motor cable in connector JDX1 for pinch points and any other damage to the cable or connector. Check both ends of the cable.</p> <p>Is the cable damaged?</p>	Replace the MPF/duplex motor cable. See “Multipurpose feeder (MPF)/duplex motor cable removal” on page 4-114.	Go to step 3.
3	<p>Measure the resistance across fuse F13 on the system board.</p>  <p>Is the fuse blown?</p>	Replace the system board. See “System board removal” on page 4-148.	Go to step 4.
4	<p>Replace the MPF/duplex motor assembly. See “System board removal” on page 4-148.</p> <p>Does the error clear?</p>	Problem resolved.	Replace the system board. See “System board removal” on page 4-148.

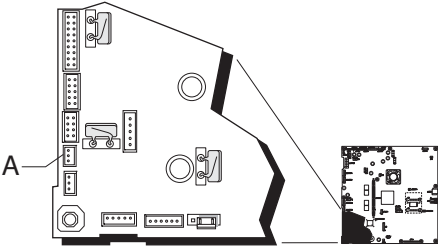
920.26—POST service check

Step	Questions / actions	Yes	No
1	<p>Open the top access cover.</p>  <p style="text-align: center;">A</p> <p>Is the top cover sensor damaged?</p>	Replace the top cover sensor.	Go to step 2.
2	<ol style="list-style-type: none"> 1. Turn the printer off. 2. Remove the rear frame cover. See “Rear cover removal” on page 4-37. 3. Check the cable in the connector JFDS1 (A) for proper connection to the system board, pinch points, and the cable or connector for any other damage.  <p>Is the cable damaged?</p>	Replace the top cover sensor.	Go to step 3.
3	<ol style="list-style-type: none"> 1. Disconnect the cable in connector JFDS1. 2. Connect the new top cover sensor. 3. Bring the printer up in the Diagnostics menu (turn off the printer, press and hold 3 and 6, turn on the printer.) 4. Touch Sensor Tests. 5. Touch Dynamic Sensors. 6. Touch Top Door. 7. Activate the top cover sensor by pressing the flag as shown.  <p>Does the display on the touchscreen change from Open to Closed?</p>	Replace the top cover sensor.	Replace the system board. See “System board removal” on page 4-148.

920.27, 920.28, 920.29—POST (power on self test) service check

Step	Questions / actions	Yes	No
1	Is the specified option the 550-sheet tray?	Replace the 550-sheet tray with a new 550-sheet tray option.	Go to step 2.
2	Is the specified option the special media tray?	Replace the special media tray with a new special tray option.	Go to step 3.
3	Is the specified option the high-capacity input tray (HCIT)?	Replace the HCIT controller board assembly. See "HCIT controller board assembly removal" on page 4-256	

925.01, 925.03, 925.05—Fan error service check

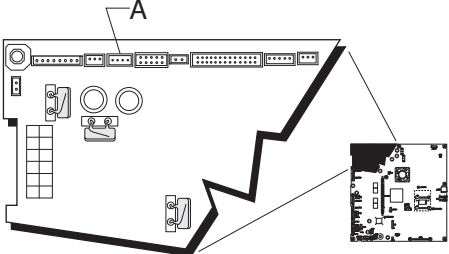
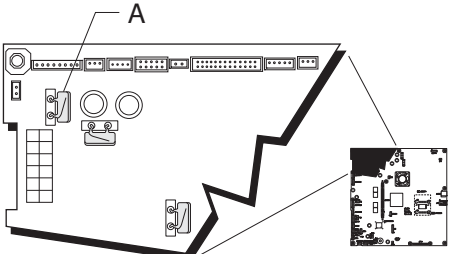
Step	Questions / actions	Yes	No
1	<p>Turn the printer off, and then remove the rear frame cover. See "Rear frame cover removal" on page 4-38.</p> <p>Check the cable in connector JFAN1 for proper connection to the system board, for pinch points, and for any other damage to the cable or the connector.</p>  <p>Is the cable damaged?</p>	Replace the fan. See "Cooling fan removal" on page 4-65.	Go to step 2.
2	<p>Measure the resistance across fuse F5 on the system board.</p>  <p>Is the fuse blown?</p>	Replace the system board. See "System board removal" on page 4-148.	Go to step 3.
3	<p>Disconnect the cable in connector JFAN1, and plug in a new cooling fan. Turn the multifunction printer off, and turn the MFP on (perform a POR).</p> <p>Did the error clear?</p>	Replace the fan. See "Cooling fan removal" on page 4-65.	Replace the system board. See "System board removal" on page 4-148.

925.02, 925.04, 925.06—Blower error service check

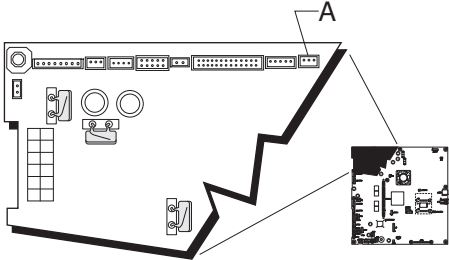
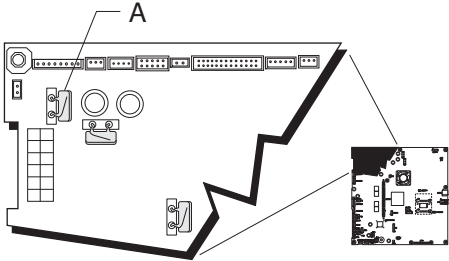
Step	Questions / actions	Yes	No
1	<p>Turn the printer off, and remove the rear frame cover. See “Rear frame cover removal” on page 4-38.</p> <p>Check the cable in connector JBLW1 for proper connection to the system board, for pinch points, and any other damage to the cable or connector.</p>  <p>Is the cable damaged?</p>	<p>Replace the blower. See “Cartridge cooling fan removal” on page 4-53.</p>	<p>Go to step 2.</p>
2	<p>Measure the resistance across fuse F5 on the system board.</p>  <p>Is the fuse blown?</p>	<p>Replace the system board. See “System board removal” on page 4-148.</p>	<p>Go to step 3.</p>
3	<p>Disconnect the cable in connector JBLW1, and plug in a new cartridge cooling fan (blower fan). Turn the multifunction printer off, and turn the MFP on (perform a POR).</p> <p>Did the error clear?</p>	<p>Replace the cartridge cooling fan. See “Cartridge cooling fan removal” on page 4-53.</p>	<p>Replace the system board. See “System board removal” on page 4-148.</p>

945.xx, 947.xx—Transfer roll error service check

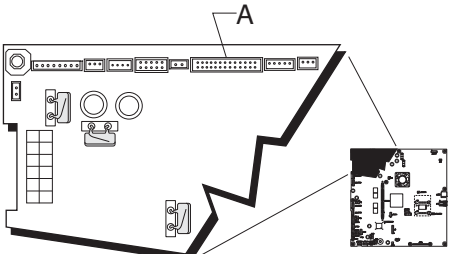
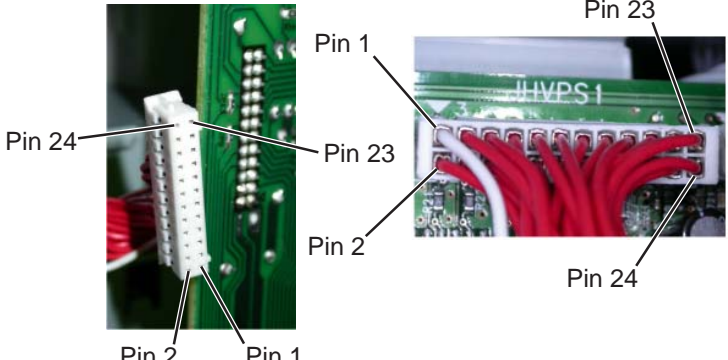
Step	Questions / actions	Yes	No																									
1	Replace the transfer module. See “Transfer module removal” on page 4-168 . POR the printer. Did the error clear?	Problem resolved.	Replace the original transfer module. Go to step 2.																									
2	Turn the printer off, and then remove the rear frame cover. See “Rear frame cover removal” on page 4-38 . Check the cable in connector JHVPS1 for proper connection to the system board, the cable for pinch points, and the cable or connector for any other damage.  Is the cable damaged?	Replace the HVPS cable. See “High-voltage power supply (HVPS) cable removal” on page 4-102 .	Go to step 3.																									
3	Disconnect JHVPS1 from system board and HVPS. Check for the following continuity.  <table border="1" data-bbox="373 1480 966 1848"> <thead> <tr> <th colspan="2">JHVPS1 cable to:</th> <th rowspan="2">Error code</th> </tr> <tr> <th>HVPS</th> <th>System board</th> </tr> </thead> <tbody> <tr> <td>Pin 19</td> <td>Pin 19</td> <td rowspan="2">945.01, 946.01, 947.01</td> </tr> <tr> <td>Pin 20</td> <td>Pin 20</td> </tr> <tr> <td>Pin 15</td> <td>Pin 15</td> <td rowspan="2">945.02, 946.02, 947.02</td> </tr> <tr> <td>Pin 16</td> <td>Pin 16</td> </tr> <tr> <td>Pin 17</td> <td>Pin 17</td> <td rowspan="2">945.03, 946.03, 947.03</td> </tr> <tr> <td>Pin 18</td> <td>Pin 18</td> </tr> <tr> <td>Pin 23</td> <td>Pin 23</td> <td rowspan="2">945.04, 946.04, 947.04</td> </tr> <tr> <td>Pin 24</td> <td>Pin 24</td> </tr> </tbody> </table> Is continuity present?	JHVPS1 cable to:		Error code	HVPS	System board	Pin 19	Pin 19	945.01, 946.01, 947.01	Pin 20	Pin 20	Pin 15	Pin 15	945.02, 946.02, 947.02	Pin 16	Pin 16	Pin 17	Pin 17	945.03, 946.03, 947.03	Pin 18	Pin 18	Pin 23	Pin 23	945.04, 946.04, 947.04	Pin 24	Pin 24	Go to step 4.	Replace the HVPS cable. See “High-voltage power supply (HVPS) cable removal” on page 4-102 .
JHVPS1 cable to:		Error code																										
HVPS	System board																											
Pin 19	Pin 19	945.01, 946.01, 947.01																										
Pin 20	Pin 20																											
Pin 15	Pin 15	945.02, 946.02, 947.02																										
Pin 16	Pin 16																											
Pin 17	Pin 17	945.03, 946.03, 947.03																										
Pin 18	Pin 18																											
Pin 23	Pin 23	945.04, 946.04, 947.04																										
Pin 24	Pin 24																											

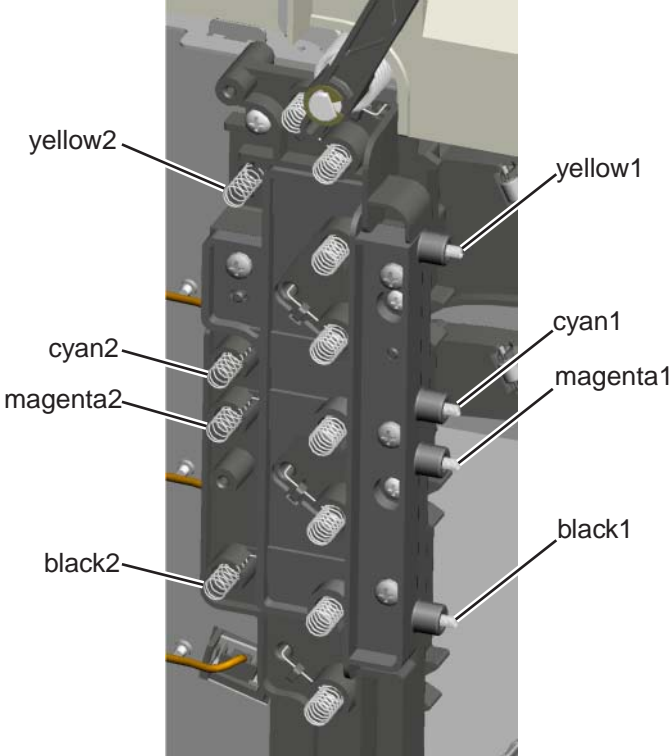
Step	Questions / actions	Yes	No
4	<p>Remove the HVPS. See “High-voltage power supply (HVPS) removal” on page 4-100. Check for continuity between the contacts (yellow1 and yellow2, cyan1 and cyan2, magenta1 and magenta2, or black1 and black2) on the transfer contact assembly.</p>  <p>Is continuity present?</p>	Go to step 5.	Replace the transfer contact assembly.
5	<p>Replace the HVPS. See “High-voltage power supply (HVPS) removal” on page 4-100.</p> <p>Does the error clear?</p>	Problem resolved.	Replace the system board. See “System board removal” on page 4-148 .

950.00–950.29—EPROM mismatch failure



Warning: When replacing any one of the following components:

- Scanner MDC card or flatbed scanner
- System board

Replace only one component at a time or the MFP will be rendered inoperable. Replace the required component, and bring the MFP up in Diagnostic Menu (see **“Accessing test and diagnostic procedure menus” on page 3-1**), and verify that the problem is fixed before performing a POR.

This error code indicates a mismatch between the system board and the scanner MDC card.

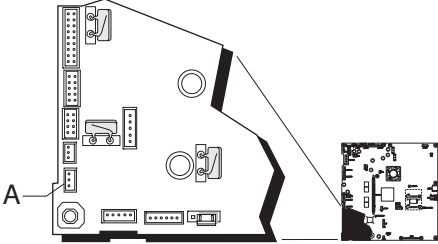
Step	Questions / actions	Yes	No
1	Has the MDC card been replaced recently?	Replace the scanner MDC card with a new and previously installed scanner MDC card. See “Scanner MDC card removal” on page 4-247 .	Go to step 2.
2	Has the flatbed scanner been replaced recently?	Replace the flatbed scanner with a new and not previously installed flatbed scanner. See “Flatbed scanner removal” on page 4-240 .	Go to step 3.
3	Has the system board been replaced recently?	Replace the system board with a new and not previously installed system board. See “System board removal” on page 4-148 .	Go to step 4.
4	Turn the printer power off for ten or more seconds. Then turn the power back on (POR the printer). Is the error gone, and can the printer print?	Problem resolved.	Go to step 5.
5	Clear the NVRAM of the printer. 1. Turn the printer power off. 2. With the printer off, press and hold the 6 , 7 , and 8 buttons. 3. Turn the printer power on. 4. When the message Restoring Factory Defaults displays, release the buttons. If the MFP locks up on the Restoring Factory Defaults message, wait two minutes, and then turn the printer power off. After ten seconds or more, turn the printer power back on without holding down any buttons. Is the error message displayed?	Go to step 6.	Problem resolved.
6	Replace the scanner MDC card. See “Scanner MDC card removal” on page 4-247 .	Replace the system board. See “System board removal” on page 4-148 .	Problem resolved.

Step	Questions / actions	Yes	No
2	<p>Turn the printer off, and remove the rear frame cover. See “Rear frame cover removal” on page 4-38.</p> <p>Check the cable in connector JINT1 for proper connection to the system board, for pinch points, and for any other damage to the cable or connector.</p>  <p>Is the cable damaged?</p>	<p>Replace the 5 V interlock switch. See “5 V interlock switch cable removal” on page 4-48.</p>	<p>Go to step 3.</p>
3	<ol style="list-style-type: none"> 1. Disconnect the cable in connector JINT1. 2. Connect the new 5 V interlock switch to JINT1. 3. Bring the printer up in the Diagnostics menu (turn off the printer, press and hold 3 and 6, turn on the printer.) 4. Activate the new 5 V interlock switch.  <p>5. Does the display go from Close front door to the Diagnostics Menu?</p>	<p>Replace the 5 V interlock switch. See “5 V interlock switch cable removal” on page 4-48.</p>	<p>Replace the system board. See “System board removal” on page 4-148.</p>

24 V interlock switch removal

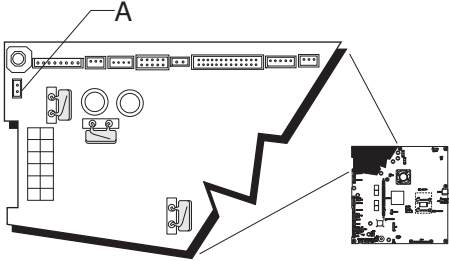
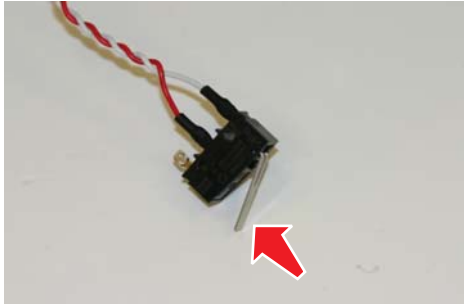
Step	Questions / actions	Yes	No
1	<p>Is the 24 V switch damaged?</p>  <p style="text-align: center;">A</p>	<p>Replace the 24 V interlock switch. See “24 V interlock switch removal” on page 4-50.</p>	<p>Go to step 2.</p>
2	<p>Turn the printer off, and remove the rear frame cover. See “Rear frame cover removal” on page 4-38.</p> <p>Check the cable in connector JCVR1 for proper connection to the system board, for pinch points, and for any other damage to the cable or connector.</p>  <p>Is the cable damaged?</p>	<p>Replace the 24 V interlock switch. See “24 V interlock switch removal” on page 4-50.</p>	<p>Go to step 3.</p>
3	<ol style="list-style-type: none"> 1. Disconnect the cable in connector JCVR1/ 2. Connect the new 24 V interlock switch. 3. Bring the printer up in the Diagnostics menu (turn off the printer, press and hold 3 and 6, turn on the printer.) 4. Activate the new 24 V interlock switch.  <p>Does the display go from Close Front Door to the Diagnostics menu?</p>	<p>Replace the 24 V interlock switch. See “24 V interlock switch removal” on page 4-50.</p>	<p>Replace the system board. See “System board removal” on page 4-148.</p>

ADF exit sensor service check

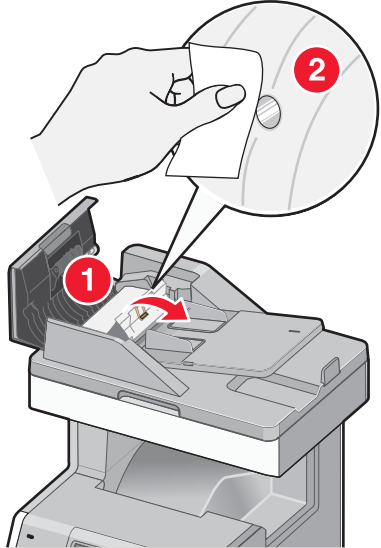
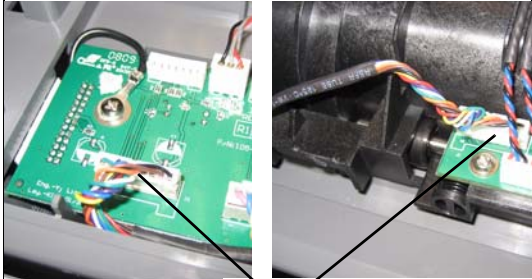
Step	Questions / actions	Yes	No
1	<p>Make sure the mirror is clean:</p> <ol style="list-style-type: none"> 1. Turn the printer off. 2. Open the ADF front cover. 3. Lift the flap as shown.  <p>Is the mirror clean?</p>	Go to step 2.	Slightly dampen a soft, lint-free cloth with water, and clean the mirror.
2	<p>Remove the ADF motor side cover. See “ADF motor side cover removal” on page 4-194.</p>  <p>A</p> <p>Is the ADF exit sensor cable (A) connected correctly?</p>	Go to step 3.	Reseat the cable in connector.
3	<p>Replace the ADF exit sensor. See “ADF exit sensor (with cable) removal” on page 4-216.</p> <p>Does the error clear?</p>	Problem resolved.	Contact the next level of support.

ADF input sensor service check

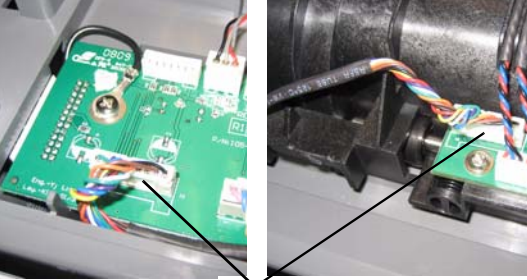
Step	Questions / actions	Yes	No
1	1. Turn the printer off. 2. Open the ADF front cover.  A Is the flag (A) damaged?	Replace the ADF case assembly. See “ADF case assembly removal” on page 4-213.	Go to step 2.
2	1. Remove the ADF front cover. See “ADF front cover removal” on page 4-190. 2. Remove the ADF motor side cover. See “ADF motor side cover removal” on page 4-194. 3. Close the ADF case assembly.  A Are the connector (A) seated correctly?	Replace the ADF case assembly. See “ADF case assembly removal” on page 4-213.	Reseat connectors

ADF jam sensor service check

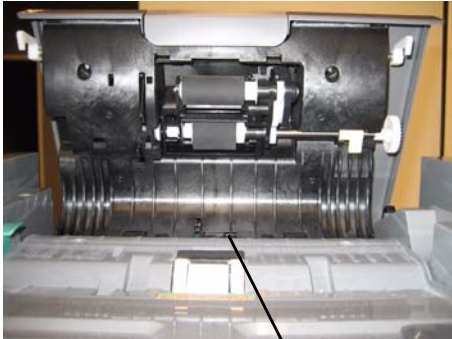
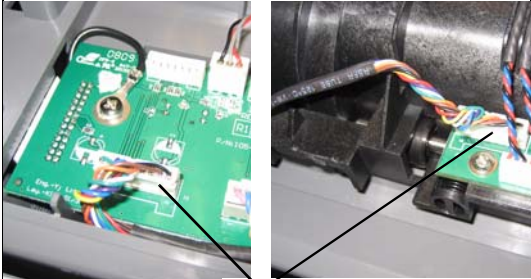
Step	Questions / actions	Yes	No
1	1. Turn the printer off. 2. Open the ADF front cover. 3. Turn the wheel.  Is the wheel (A) damaged?	Replace the ADF case assembly. See “ADF case assembly removal” on page 4-213.	Go to step 2.
2	1. Remove the ADF front cover. See “ADF front cover removal” on page 4-190. 2. Remove the ADF motor side cover. See “ADF motor side cover removal” on page 4-194. 3. Open the ADF case assembly.  Are the connectors (A) seated correctly?	Replace the ADF case assembly. See “ADF case assembly removal” on page 4-213.	Reseat the connectors.

ADF skew sensor service check

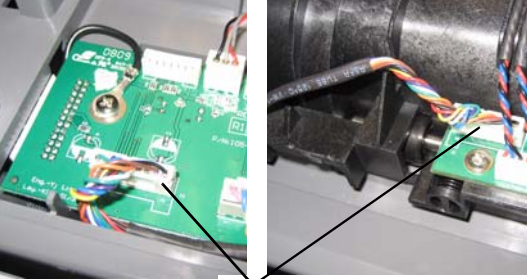
Step	Questions / actions	Yes	No
1	<p>1. Turn the printer off. 2. Open the ADF front cover. See “ADF front cover removal” on page 4-190.</p>  <p>Is the flag (A) damaged?</p>	<p>Replace the ADF case assembly. See “ADF case assembly removal” on page 4-213.</p>	<p>Go to step 2.</p>
2	<p>1. Remove the ADF front cover. See “ADF front cover removal” on page 4-190. 2. Remove the ADF motor side cover. See “ADF motor side cover removal” on page 4-194.</p>  <p>3. Open the ADF case assembly. Are the connectors (A) seated correctly?</p>	<p>Replace the ADF case assembly. See “ADF case assembly removal” on page 4-213.</p>	<p>Reseat the connectors.</p>

ADF scanning sensor service check

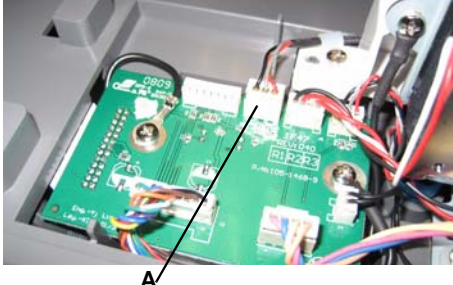
Step	Questions / actions	Yes	No
1	<p>Remove the ADF motor side cover. See “ADF motor side cover removal” on page 4-194.</p>  <p>Are the connectors seated correctly?</p>	<p>Replace the ADF. See “ADF removal (entire)” on page 4-210.</p>	<p>Reseat connector.</p>

Bubble sensor service check

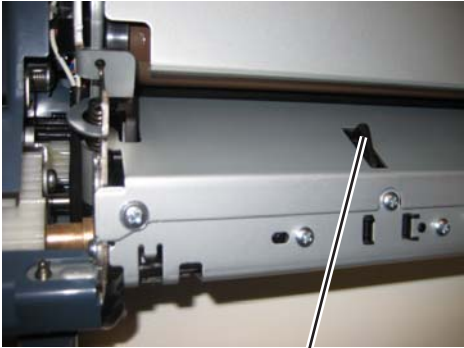
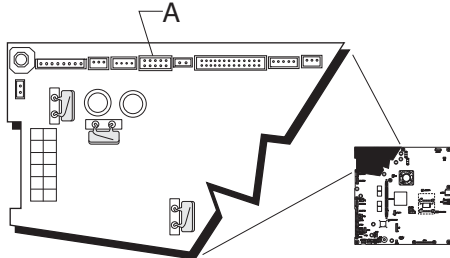
Step	Questions / actions	Yes	No
1	<p>Is the bubble sensor flag (A) damaged?</p> 	<p>Replace the fuser. See “Fuser assembly removal” on page 4-94.</p>	<p>Go to step 2.</p>
2	<p>Remove the rear frame cover. See “Rear frame cover removal” on page 4-38.</p> <p>Check the fuser DC cable in connector JFUSER1 for proper connection to the system board, pinch points, and any other damage to the cable or connector.</p>  <p>Is the cable damaged?</p>	<p>Replace the fuser DC cable. See “Fuser DC cable removal” on page 4-97.</p>	<p>Go to step 3.</p>

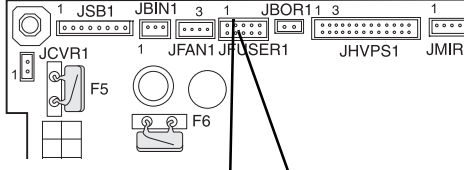
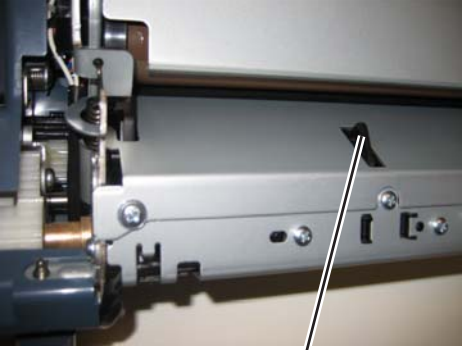
Step	Questions / actions	Yes	No
3	<p>Place a voltmeter between fuser DC autoconnect pin 3, and ground (pin 6).</p>  <p>Pin 3 Pin 6 (ground)</p> <p>Does the meter read +5 V dc?</p>	Go to step 5.	Go to step 4.
4	<p>Place a voltmeter between the JFUSER1, pin 3 and ground (pin 6).</p>  <p>Pin 3 Pin 6 (ground)</p> <p>Does the voltage drop to +5 V dc?</p>	Replace the system board. See “System board removal” on page 4-148.	Replace the fuser. See “Fuser assembly removal” on page 4-94.
5	<ol style="list-style-type: none"> 1. Replace the fuser. 2. Bring the printer up in the Diagnostics menu (turn off the printer, press and hold 3 and 6, turn on the printer.) 3. Touch SENSOR TESTS. 4. Touch Dynamic Sensors. 5. Touch Bubble. 6. Open the front access door and the top access cover. 7. Activate the bubble sensor flag (A).  <p>A</p> <p>Did the bubble sensor change from Open to Closed on the touchscreen?</p>	Problem resolved.	Replace the system board. See “System board removal” on page 4-148.

Dead printer service check

A dead printer is a condition where the display is blank, the LED on the operator panel is off, no fans turn, no motors turn, and the fuser lamp does not come on.

If a 550-sheet option assembly is installed, remove the option, and check the base printer for correct operation. If the base printer operates correctly, replace the 550-sheet option assembly.

Warning: Observe all necessary ESD precautions when removing and handling the system board or any installed option cards or assemblies. See **“Handling ESD-sensitive parts” on page 4-2.**

	<p>CAUTION</p> <p>When you see this symbol, there is a danger from hazardous voltage in the area of the product where you are working. Unplug the product before you begin, or use caution if the product must receive power in order to perform the task.</p>
---	---

Remove any input and output paper handling options from the printer.

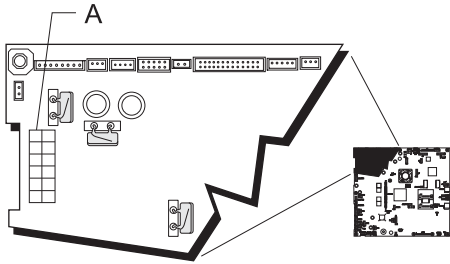
Step	Questions / actions	Yes	No
1	Check the AC line voltage. Is the line voltage correct?	Go to step 2.	Inform the customer.
2	Is the AC line cord damaged?	Replace the line cord.	Go to step 3.
3	Check the system board for +5 V dc between JLVPS2 pin 1 and ground. Is the voltage correct?	Replace the system board. See “System board removal” on page 4-148.	Go to step 4.
4	Is the JLVPS2 cable correctly installed at JLVPS2 on the system board? 	Go to step 5.	Reseat the JLVPS2 cable.
5	1. Turn the printer off. 2. Disconnect the JLVPS2 cable from the system board. 3. Turn the printer on. 4. Measure the voltage between the JLVPS2 cable pin 1 and the JLVPS2 pin 14 (black wire). Does this measure approximately +5 V dc?	Go to step 6.	Replace the LVPS. See “Low-voltage power supply (LVPS) removal” on page 4-104.

Step	Questions / actions	Yes	No
6	<p>1. Turn the printer off.</p> <p>2. Disconnect cables J5, JCARTS1, JCARTS2, JDVR1, JFDPCK1, JFUSER1, JINT1, JOPT1, and JTLB%1.</p> <p>3. Connect the JLVPS2 cable to the system board. Remove one option/feature at a time, and then turn the printer on to isolate the failing part.</p> <p>Warning: Observe all the ESD precautions (see “Handling ESD-sensitive parts” on page 4-2) and turn the printer off before any feature or option cards are removed or replaced.</p> <p>Is a failing part found?</p>	Contact your next level of support. Replace the faulty part.	Go to step 7.
7	<p>1. Connect one cable at a time and POR the printer.</p> <p>2. Is the printer still dead?</p>	The part connect to that cable is faulty. Replace the failing part.	Connect another cable, and then continue with this step.

Exit sensor service check

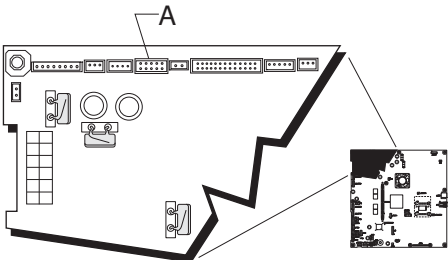
Step	Questions / actions	Yes	No
1	<p>Verify the paper is loaded properly in the paper tray or manual feed slot.</p> <p>Is the paper properly loaded?</p>	Go to step 2.	Load paper correctly.
2	<p>Turn the printer off, and remove the fuser. See “Fuser assembly removal” on page 4-94.</p> <p>POR the printer.</p> <p>Did the error clear?</p>	Problem resolved.	Remove the new fuser, and go to step 3.
3	<p>Remove the rear frame cover. See “Rear frame cover removal” on page 4-38.</p> <p>Check the fuser DC cable in the connector JFUSER1 for proper connection to the system board, for pinch points, and for any other damage to the cable or the connector.</p>  <p>Is the cable damaged?</p>	Replace the fuser DC cable. See “Fuser DC cable removal” on page 4-97 .	Go to step 5.

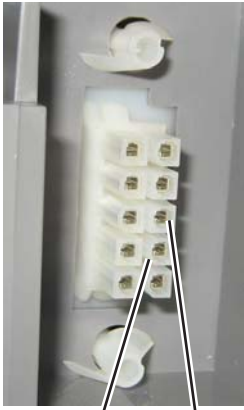
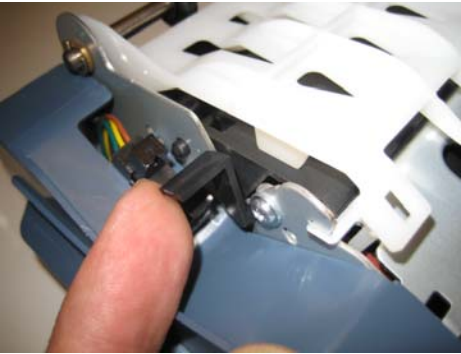
Step	Questions / actions	Yes	No
4	<p>Place a voltmeter between the fuser DC autoconnect pin 8 and ground (pin 6).</p>  <p>Pin 8 Pin 6(ground)</p> <p>Does the meter read +5 V dc?</p>	Go to step 6.	Go to step 5.
5	<p>Place a voltmeter between the connector JFUSER1 pin 8 and ground (pin 6) on the system board.</p> <p>Does the meter read +5 V dc?</p>	Go to step 6.	Replace the fuser DC cable. See “Fuser DC cable removal” on page 4-97.
6	<ol style="list-style-type: none"> 1. Replace the fuser. 2. Bring the printer up in Diagnostics Menu (turn the multifunction printer off, press and hold 3 and 6, turn the MFP on, and then release the buttons when the progress bar displays). 3. Touch SENSOR TESTS. 4. Touch Dynamic Sensors. 5. Touch Fuser Exit. 6. Open the front door, and then the top access cover. 7. Activate the fuser exit sensor.  <p>Did the fuser exit sensor change from Open to Closed?</p>	Problem resolved.	Replace the system board. See “System board removal” on page 4-148.

Input sensor service check

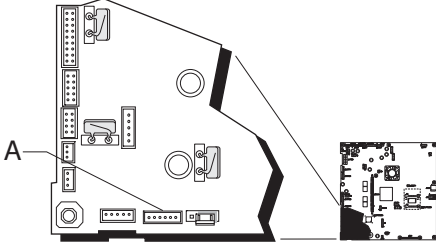
Step	Questions / actions	Yes	No
1	<p>Is the input sensor flag damaged?</p> 	<p>Replace the paper pick mechanism. See “Paper pick mechanism assembly removal” on page 4-117.</p>	<p>Go to step 2.</p>
2	<p>Turn the printer off, and then remove the rear frame cover. See “Rear frame cover removal” on page 4-38.</p> <p>Check the cable in connector JTRAY1 for proper connection to the system board, for pinch points, and any other damage to the cable or connector. Check both ends of the cable.</p>  <p>Is the cable damaged?</p>	<p>Replace the paper pick mechanism. See “Paper pick mechanism assembly removal” on page 4-117.</p>	<p>Go to step 3.</p>
3	<ol style="list-style-type: none"> 1. Disconnect the cable in the connector JTRAY1. 2. , Connect the cable to the new paper pick assembly. 3. Bring the printer up in the Diagnostics menu (turn off the printer, press and hold 3 and 6, turn on the printer.) 4. Touch SENSOR TESTS. 5. Touch Dynamic Sensors. 6. Touch Input. <p>Did the touchscreen change from Open to Closed?</p>	<p>Replace the paper pick mechanism. See “Paper pick mechanism assembly removal” on page 4-117.</p>	<p>Replace the system board. See “System board removal” on page 4-148.</p>

Networking service check

Note: Before starting this service check, print out the network setup page. This page is found under **Menu—Reports—Network Settings**. Consult the network administrator to verify that the physical and wireless network settings displayed on the network settings page for the device are properly configured. If a wireless network is used, verify that the printer is in range of the host computer or wireless access point, and there is no electronic interference. Have the network administrator verify that the device is using the correct SSID, and wireless security protocols. For more network troubleshooting information, consult the Lexmark Network Setup Guide.

Step	Questions / actions	Yes	No
1	If the device is physically connected to the network, verify that the ethernet cable is properly connected on both ends. Is the cable properly connected?	Go to step 3. If the network is wireless, got to step 3.	Go to step 2.
2	Connect the ethernet cable. Did this fix the problem?	Problem resolved	Go to step 3.
3	Check the printer's online status under Printers and Faxes on the host computer. Delete all print jobs in the print queue. Is the printer online and in a Ready state.	Go to step 5.	Go to step 4.
4	Change the printer status to online. Did this fix the issue?	Problem resolved.	Go to step 5.
5	Does the IP address displayed on the network settings page match the IP address in the port of the drivers using the printer?	Go to step 10.	Go to step 6.
6	Does the LAN use DHCP? Note: A printer should use a static IP address on a network.	Go to step 7.	Go to step 9.
7	Are the first two segments if the IP address 169.254?	Go to step 8.	Go to step 9
8	POR the printer. Is the problem resolved	Problem resolved	Go to step 10.
9	Reset the address on the printer to match the IP address on the driver. Did this resolve the issue?	Problem fixed.	Go to step 10.
10	Have the network admin verify that the printer and PC's IP address have identical subnet addresses. Are the subnet addresses the same?	Go to step 12.	Go to step 11.
11	Using the subnet address supplied by the network admin, assign a unique IP address to the printer. Note: The printer IP address should match the IP address on the printer driver. Did this fix the problem?	Problem resolved.	Go to step 12.
12	Is the device physically connected (ethernet cable) to the network?	Go to step 13.	Go to step15.

Step	Questions / actions	Yes	No
13	Try using a different ethernet cable. Did this remedy the situation?	Problem resolved.	Go to step 14.
14	Have the network administrator check the network drop for activity. Is the drop functioning properly?	Replace the system board. See "System board removal" on page 4-148.	Contact the network administrator.
15	Is the printer on the same wireless network as the other devices?	Go to step 17.	Go to step 16.
16	Assign the correct wireless network to the printer. Did this fix the problem?	Problem resolved.	Go to step 17.
17	Are the other devices on the wireless network communicating properly?	Go to step 18.	Contact the network administrator.
18	Verify that the ISP wireless card cable is properly seated in their connectors. Is the wireless card seated correctly?	Go to step 20.	Go to step 19.
19	Properly reseal the ISP cables. Did this fix the problem?	Problem resolved.	Go to step 20.
20	Replace the ISP wireless card. See Installing an Internal Solutions Port (ISP). Did this fix the problem?	Problem resolved.	Replace the system board. See "System board removal" on page 4-148.

Operator panel service check

One or more operator panel buttons fail

Step	Questions / actions	Yes	No
1	Run the Button Test. See "Button Test" on page 3-15 in Diagnostics mode. Did any of the buttons fail the test?	Replace the operator panel assembly. See "Operator panel assembly removal" on page 4-26.	Go to step 2.
2	Disconnect the operator panel assembly cable from JOPP1 on the system board, and then measure the voltage on pin 6 and ground. Does the voltage measure approximately +3.3 V dc?	Replace the operator panel assembly. See "Operator panel assembly removal" on page 4-26. If this does not fix the problem, replace the top cover access assembly. See "Top access cover assembly removal" on page 4-41.	Replace the system board. See "System board removal" on page 4-148.

Operator panel display blank, five *beeps*, and LED is off

Service tip: The printer has detected a problem with the system board, the operator panel assembly cable (part of the top cover access assembly), or the operator panel assembly if POST does not complete. The printer emits five *beeps*, and then sticks in a continuous pattern until the printer is turned off.

Step	Questions / actions	Yes	No
1	Is the operator panel assembly cable properly installed at system board JOPP1 and at the operator panel assembly?	Go to step 2.	Reinstall the cable.
2	Measure the voltage between JOPP1 pin 2 and ground on the system board. Is the voltage approximately +5 V dc?	Go to step 3.	Replace the system board. See " System board removal " on page 4-148.
3	Check continuity of the operator panel assembly cable. Is there continuity?	Replace the operator panel assembly. See " Operator panel assembly removal " on page 4-26.	Replace the top cover access assembly. See " Top access cover assembly removal " on page 4-41.

Operator panel display blank, five *beeps*, LED on

Service tip: The printer has detected a problem with the system board, the operator panel assembly cable (part of the top cover access assembly), or the operator panel assembly if POST does not complete. The printer emits five *beeps*, and then sticks in a continuous pattern until the printer is turned off.

Step	Questions / actions	Yes	No
1	Check for ground between JOPP1 pin 4 and ground. Is the voltage approximately 0 V dc?	Replace the operator panel assembly. See " Operator panel assembly removal " on page 4-26.	Go to step 2.
2	Check the operator panel assembly cable. Is the cable damaged?	Replace the top cover access assembly. See " Top access cover assembly removal " on page 4-41.	Replace the system board. See " System board removal " on page 4-148.

Operator panel display all diamonds, no *beeps*

Step	Questions / actions	Yes	No
1	Check the operator panel assembly cable. Is the cable damaged?	Replace the top access cover assembly. See " Top access cover assembly removal " on page 4-41.	Go to step 2.
2	Measure the voltage between JOPP1 pin 2 and ground on the system board. Is the voltage approximately +5 V dc?	Replace the operator panel assembly. See " Operator panel assembly removal " on page 4-26.	Replace the system board. See " System board removal " on page 4-148.

Operator panel display all diamonds, five beeps

Step	Questions / actions	Yes	No
1	Check the operator panel assembly cable. Is the cable damaged?	Replace the top access cover assembly. See " Top access cover assembly removal " on page 4-41.	Go to step 2.
2	Measure the voltage between JOPP1 pin 2 and ground on the system board. Is the voltage approximately +5 V dc?	Replace the operator panel assembly. See " Operator panel assembly removal " on page 4-26.	Replace the system board. See " System board removal " on page 4-148.

Print quality service check

Note: This symptom may require replacement of one or more CRUs (Customer Replaceable Units) designated as supplies or maintenance items, which are the responsibility of the customer. With the customer's permission, you may need to install a developer (toner) cartridge or photoconductor unit.

Service tip: Before troubleshooting any print quality problems, do the following:

1. Print a menu settings page, and then check the life status of all supplies. Any supplies that are low should be replaced.

Note: Be sure and keep the original menu page to restore the customer's custom settings if needed.

2. On the menu page, make sure the following is set to the default level:
 - Color Correction: Set to Auto.
 - Print Resolution: Set to 1200 dpi (print quality problems should be checked at different resolution settings).
 - Toner Darkness: Set to 4 (default).
 - Color Saver: Set to OFF.
 - RGB Brightness, RGB Contrast, RGB Saturation: Set to 0.
 - Color Balance: Touch **Reset Defaults** to zero out all colors.
 - Check the paper type, texture and weight settings against what is loaded in the printer.

Once the printer has been restored to its default levels, do the following:

3. Inspect the transfer module for damage. Replace if damaged.
4. Inspect the OPCs and toner cartridges for damage. Replace if damaged.
5. If paper other than 20lb plain letter/A4 paper is being used, load 20lb plain letter/A4 and print the Print Quality pages to see if the problem remains.
6. Use Tray 1 to test print quality problems.
7. Print the Print Quality Pages, and then look for variations in the print from what is expected.

An incorrect printer driver for the installed software can cause problems. Incorrect characters could print, and the copy may not fit the page correctly.

Measure all voltages from the connector to the printer ground.

Print quality—background

Service tip: Some background problems can be caused by rough papers, non-Lexmark toner cartridges or if the media texture is set to the rough setting.

Some slick or coated papers may also cause background problems. Some problems occur with printers that run a large amount of graphics in a humid environment.

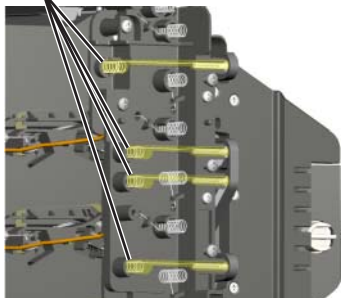
Step	Questions / actions	Yes	No
1	<p>Read the current status of the photoconductor unit from the customer menus.</p> <p>To view the status of the photoconductor units:</p> <ol style="list-style-type: none"> 1. In Ready mode, press Admin Menu. 2. Touch Reports. 3. Touch Device Statistics. <p>Ask the customer if the photoconductor unit has been recently replaced. It is possible the photoconductor value was not reset and the photoconductor unit is past end of life. If the PC unit was recently replaced, reset the value. If the PC unit was not replaced, replace the PC unit.</p> <p>Has the photoconductor unit been recently replaced?</p>	<p>Reset the value. To reset this value:</p> <ol style="list-style-type: none"> 1. In Ready mode, press Admin Menu. 2. Touch Supplies Menu. 3. Touch Replace Supply. 4. Select the PC color unit you want to change 5. Touch Yes. <p>If this does not fix the problem, go to step 2.</p>	Go to step 2.
2	<p>Replace the PC unit. See “Photoconductor unit removal” on page 4-124.</p> <p>Does this fix the problem?</p>	Problem resolved.	Go to step 3.
3	<p>Check the high voltage contact from the HVPS to the transfer module.</p> <p>Transfer belt high voltage path (typical 4X)</p>  <p>Is a problem found?</p>	Replace the spring or the transfer contact assembly.	Go to step 4.
4	<p>Reseat the JHVPS connector.</p> <p>Does this fix the problem?</p>	Problem resolved.	Go to step 5.
5	<p>Replace the HVPS. See “High-voltage power supply (HVPS) removal” on page 4-100.</p> <p>Does this fix the problem?</p>	Problem resolved.	Go to step 6.
6	<p>Clean the printhead.</p> <p>Does this fix the problem?</p>	Problem resolved.	Replace the printhead. See “Printhead removal, installation, and adjustment” on page 4-128 .

Print quality—blank page

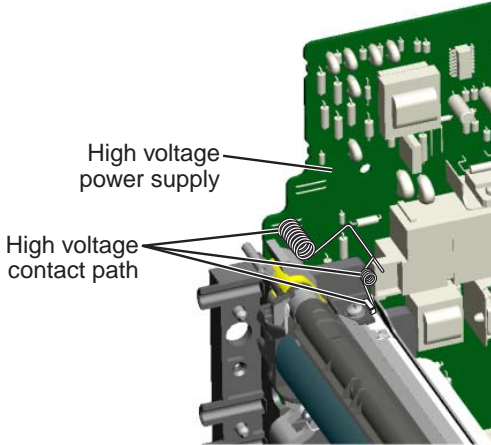
Step	Questions / actions	Yes	No
1	Is all the packing material for the photoconductor unit in question removed?	Go to step 2.	Remove the packing material.
2	Replace the photoconductor unit for the color in question. Does this fix the problem?	Problem resolved.	Go to step 3.
3	Enter the Diagnostics mode (turn off the printer, press and hold 3 and 6 , turn on the printer, and release the buttons when the clock graphic displays). Perform the appropriate cartridge drive motor test for the missing color. See “General motor tests procedures” on page 3-12. Did the motor run?	Go to step 5.	Replace the EP drive assembly. See “Electrophotographic (EP) drive assembly removal” on page 4-70.
4	Check the high voltage contact from the HVPS to the photoconductor charge roll. Ensure the contact springs are properly mounted and that the charge roll contact spring is making good contact with the HVPS spring that runs through the left printer frame.  Are the spring(s) defective?	Replace the transfer contact assembly.	Go to step 6.

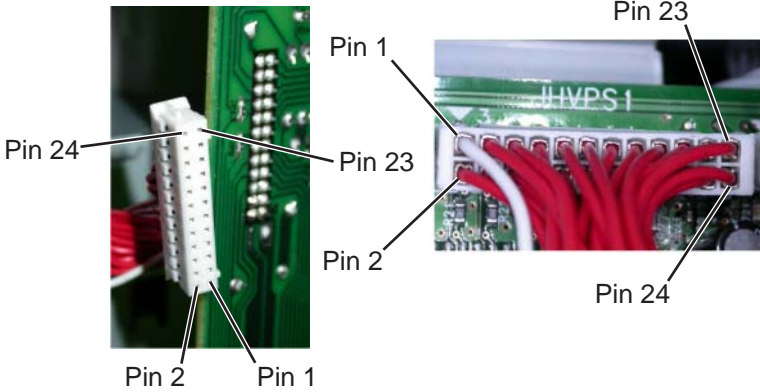
Step	Questions / actions	Yes	No
5	Turn off the printer and check the continuity of the HVPS cable.  Is there continuity?	Go to step 7.	Replace the cable assembly.
6	Replace the HVPS. See “High-voltage power supply (HVPS) removal” on page 4-100. Did this fix the problem?	Problem resolved.	Go to step 8.
7	Replace the printhead. See “Printhead removal, installation, and adjustment” on page 4-128. Did this fix the problem?	Problem resolved.	Replace the system board. See “System board removal” on page 4-148.

Print quality—blurred or fuzzy print

Blurred or fuzzy print is usually caused by a problem in the EP drive assembly or in the transfer module. Check the EP drive assembly and transfer module for correct operation.

Blurred print can also be caused by incorrect feeding from one of the input paper sources, paper trays, or duplex paper path.

Check the high voltage spring contacts to ensure they are not bent, corroded, or damaged. Replace as necessary.

Print quality—half-color page

A photoconductor unit is not properly seated. Reset the specific photoconductor unit.

Print quality—horizontal banding

Step	Questions / actions	Yes	No
1	Measure the distance between repeating bands. Is the distance between bands either 27 or 36mm?	Replace the print cartridge.	Replace the photoconductor unit. See “Printhead removal, installation, and adjustment” on page 4-128.

Print quality—horizontal line

The photoconductor unit is defective. Replace the photoconductor unit.

Print quality—insufficient fusing

Step	Questions / actions	Yes	No
1	Is the fuser properly installed?	Go to step 2.	Install the fuser properly.
2	Replace the fuser. See “Fuser assembly removal” on page 4-94. Does this fix the problem?	Problem resolved.	Replace the LVPS. see “Low-voltage power supply (LVPS) removal” on page 4-104.

Print quality—missing image at edge

Reseat the developer cartridge.

Print quality—mottle (2–5mm speckles)

Keep running prints through, and the problem normally clears up. If the problem persists, replace the developer cartridge.

Print quality—narrow vertical line

Step	Questions / actions	Yes	No
1	Replace the photoconductor unit. See “Photoconductor unit removal” on page 4-124.	Problem resolved.	Replace the print cartridge.

Print quality—random marks

Service tip: The primary cause of random marks is due to loose material moving around inside the printer and attaching to the photoconductor unit, developer roll, or transfer belt.

Step	Questions / actions	Yes	No
1	Is there any loose or foreign material on the photoconductor unit?	Replace the photoconductor unit. See “Photoconductor unit removal” on page 4-124.	Go to step 2.
2	Is there any loose or foreign material on the cartridge roll?	Replace the print cartridge.	Go to step 3.
3	Is there any loose or foreign material on the transfer belt?	Replace the transfer module. See “Transfer module removal” on page 4-168.	Contact your next level of support.

Print quality—residual image

Service tip: Install a new print cartridge if available before doing this service check. Residual image can be caused by the photoconductor, cleaning blade, and other parts inside the print cartridge.

Step	Questions / actions	Yes	No
1	Is there any toner contamination on the fuser assembly?	Replace the fuser. See “Fuser assembly removal” on page 4-94.	Contact your next level of support.

Print quality—solid color page

Service tip: A solid color page is generally caused by a problem in the high voltage system or an incorrect high voltage in the printing process resulting in toner development on the entire photoconductor drum.

Step	Questions / actions	Yes	No
1	Replace the photoconductor unit for the color in question. Does this fix the problem?	Problem resolved.	Go to step 2.
2	<div data-bbox="142 919 240 1003" style="float: left; margin-right: 10px;"> </div> Check the high voltage contact from the HVPS to the photoconductor charge roll. Ensure the contact springs are properly mounted and that the charge roll contact spring is making good contact with the HPVS spring that runs through the left printer frame. <div style="text-align: center; margin-top: 10px;"> </div> <p style="margin-left: 20px;">High volt power supply</p> <p style="margin-left: 20px;">High volt contact path</p> <p style="margin-left: 20px;">Note: Printer is shown with components removed for clarity</p> Are the spring(s) defective?	Replace the transfer contact assembly.	Go to step 3.

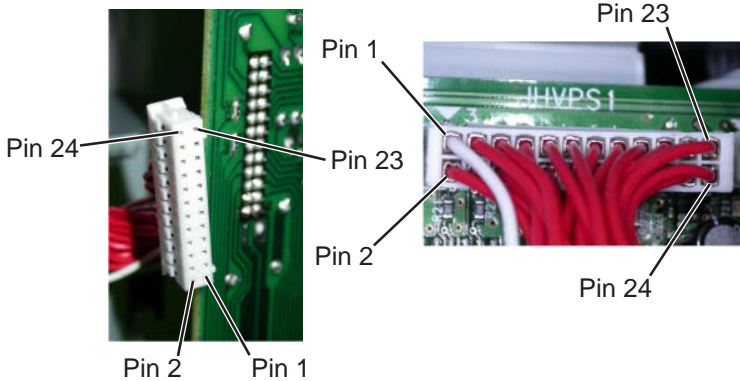
Step	Questions / actions	Yes	No
3	<p>Turn the printer off, and then check the continuity of the HVPS cable.</p>  <p>Is there continuity?</p>	Go to step 4.	Replace the cable assembly.
4	<p>Replace the HVPS. See “High-voltage power supply (HVPS) removal” on page 4-100.</p> <p>Did this solve the problem?</p>	Problem resolved.	Replace the system board. See “System board removal” on page 4-148.

Print quality—vertical banding



Replace the developer cartridge.

3. Diagnostic aids

This chapter explains the tests and procedures to identify printer failures and verify repairs have corrected the problem.

Accessing test and diagnostic procedure menus

There are different test and diagnostic menus that can be accessed during POR to identify problems with the multiple function printer. Turn off the MFP and turn it back on while holding particular keys. You may also have to satisfy any security protocols that system administrators may have been placed on these menus.

Diagnostics menu	<ol style="list-style-type: none"> 1. Turn off the multifunction printer. 2. Press and hold 3 and 6.  <ol style="list-style-type: none"> 3. Turn on the MFP. 4. Release the buttons when the progress bar displays. 	<p>The Diagnostics menu group contains the settings and operations used while manufacturing and servicing the printer.</p> <p>See “Diagnostics menu” on page 3-3 for more information.</p>
Configuration menu	<ol style="list-style-type: none"> 1. Turn off the multifunction printer. 2. Press and hold 2 and 6.  <ol style="list-style-type: none"> 3. Turn on the MFP. 4. Release the buttons when the progress bar displays. 	<p>The Configuration menu group contains a set of menus, settings, and operations which are infrequently required by a user. Generally, the options made available in this menu group are used to configure a printer for operation.</p> <p>See “Configuration menu (CONFIG MENU)” on page 3-30 for more information.</p>
Start the multifunction printer without initializing the scanner.	<ol style="list-style-type: none"> 1. Turn off the multifunction printer. 2. Press and hold 3 and 7.  <ol style="list-style-type: none"> 3. Turn on the MFP printer. 4. Release the buttons when the progress bar displays. 	

Network SE menu	<p>While in Network/Ports Menu (Menus—Network/Ports—Standard Network—STD NET SETUP), press and hold 9, 7, and 6.</p> 	The Network SE menu contains advanced network menu tools.
Fax SE menu	From the HomePrime screen, press **411	
SE menu	From a browser, add “/se” to device’s IP address (for example: http://158.183.3.2/se)	See “Service Engineer (SE) Menu” on page 3-48 for a listing of the menus.

Diagnosics menu

Diagnosics menu structure

When the Diagnostics menu is entered, each item displays on the operator panel. When a diagnostic test is selected from the main menu, a sub menu displays and each individual test displays in the order shown. Any options that are referred to in the menus are displayed when the option is installed.

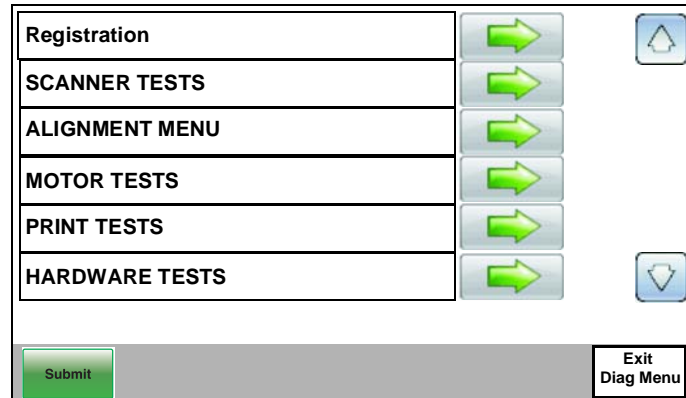

Available tests

The tests display on the operator panel in the order shown:

Registration	
Top Margin	See “Registration” on page 3-6.
Bottom Margin	
Left Margin	
Right Margin	
Skew	See “Skew” on page 3-6.
Quick Test	See “Quick Test” on page 3-8.
SCANNER TESTS	
ASIC	
Feed Test	
Sensor Test	
ALIGNMENT MENU	
Cyan	See “Alignment Menu” on page 3-11.
Yellow	
Magenta	
Factory Scanner	
Factory Manual	A summary page for all the color alignment settings. Can be used in place of alignment pages for each individual color.

MOTOR TESTS (order differs depending upon model)	
Align Motor Test	See “General motor tests procedures” on page 3-12.
Cart 1	
Cart 2	
Cart 3	
CAM	
COD	
DUPLEX	
MPF	
Transfer Belt	
Tray 1	
PRINT TESTS	
Tray 1	See “Input source tests” on page 3-13.
Tray 2 (if installed)	
Tray 3 (if installed)	
Tray 4 (if installed)	
Tray 5 (if installed)	
Multi-Purpose Feeder	
Prt Quality Pgs	See “Print quality test pages (Prt Quality Pgs)” on page 3-14.
HARDWARE TESTS	
Panel Test	See “Panel Test” on page 3-15.
Button Test	See “Button Test” on page 3-15.
DRAM Test	See “DRAM Test” on page 3-16.
Serial 1 Wrap (if a serial port is available in the PCI slot 1)	See “Serial 1 Wrap” on page 3-16.
USB HS Test Mode	See “USB HS Test Mode” on page 3-17.
DUPLEX TESTS (if installed)	
Quick Test	See “Quick Test (duplex)” on page 3-18.
Print Test	See “Print Test (duplex)” on page 3-19.
Top Margin	See “Top Margin (duplex)” on page 3-20.
Left Margin	See “Left Margin (duplex)” on page 3-20.
Skew	See “Skew (duplex)” on page 3-20.
Sensor Tests	
Static Sensors	See “Sensor Tests” on page 3-21.
Dynamic Sensors	
Other Sensors	
PRINthead TESTS	
Mirror Motor Test	See “Mirror Motor Test” on page 3-22.
Servo Laser Test	See “Servo Laser Test” on page 3-22.
DEVICE TESTS (if hard disk or flash is installed)	
Quick Disk Test	See “Quick Disk Test” on page 3-22.
Disk Test/Clean	See “Disk Test/Clean” on page 3-23.
Flash Test	See “Flash Test” on page 3-23.

PRINTER SETUP	
Defaults	See “Defaults” on page 3-23.
Prt Color Page Count	See “Page Counts” on page 3-24.
Prt Mono Page Count	
Perm Page Count	
Serial Number	See “Serial Number” on page 3-24.
Engine Setting 1 through 4	See “Engine Setting 1 through 4” on page 3-24.
Model Name	See “Model Name” on page 3-24.
Configuration ID	See “Configuration ID” on page 3-25.
Reset Color Cal	See “Reset color calibration (Reset Color Cal)” on page 3-26.
Par 1 Strobe Adj	See “Parallel 1 strobe adjustment (Par 1 Strobe Adj)” on page 3-26.
Motor Calibration	See “Motor Calibration” on page 3-26.
EP SETUP	
EP Defaults	See “EP Defaults” on page 3-26.
Fuser Temp	See “Fuser temperature (Fuser Temp)” on page 3-27.
DC Charge Adjust	See “DC Charge Adjust, Dev Bias Adj, Transfer Adjust” on page 3-27.
Dev Bias Adj	
Transfer Adjust	
REPORTS	
Menu Settings Page	See “Menu Settings Page” on page 3-27.
EVENT LOG	
Display Log	See “Display Log” on page 3-28.
Print Log	See “Print Log” on page 3-28.
Clear Log	See “Clear Log” on page 3-29.
EXIT DIAGNOSTICS	This selection exits Diagnostics mode, and then Resetting the Printer displays. The printer performs a POR, and then returns to normal mode.

Registration

Note: If you need to perform alignment or registration, see **“Printhead alignment”** on page 4-9.

The following information is meant to explain the uses for the menu items.

Print registration makes sure the black printing is properly aligned on the page. This is one of the steps in aligning a new printhead. It is also the first step in aligning the duplex registration. See **“Quick Test (duplex)”** on page 3-18.

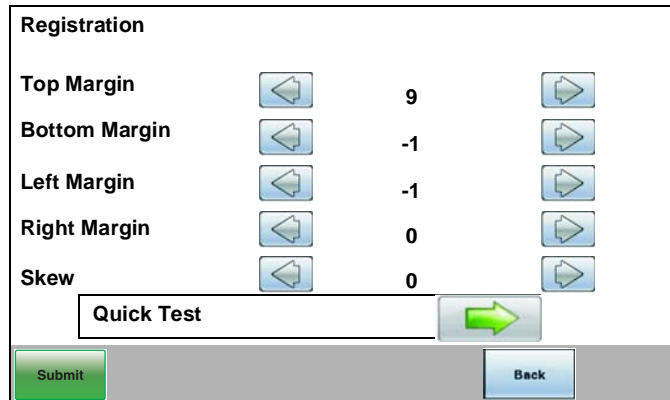

The settings available are Top Margin, Bottom Margin, Left Margin, Right Margin, Skew, and Quick Test.

Skew

One printhead houses the four color planes. The black plane is aligned to the printer, and then the color planes are internally aligned to black. Adjust the skew mechanically by moving the printhead with a printhead adjustment screw. See **“Printhead mechanical alignment”** on page 4-9 for instructions on setting printhead alignment. Electronic alignment fine tunes the alignment of the color planes to the black plane once the printhead is installed. Skew adjustment must be performed before color alignment is attempted. The following illustration shows proper alignment versus skewed alignment.



Print registration

To set print registration:

1. Touch **REGISTRATION** from the Diag Menu.
2. Touch **Quick Test**.

The message *Quick Test Printing...* appears on the display.

Note: Retain this page to determine the changes you need to make to the margin settings.

3. Touch the green arrow next to the margin setting you need to change.
4. Use ◀ to decrease or ▶ to increase the offset values, and then touch **Submit**.

The message *Submitting selection* displays, and then the original Registration screen appears with the ✓ beside the previously selected margin setting.

The print registration range is:

Description	Value	Direction of change
Skew	-50 to +50 Each increment corresponds to 1/1200 of an inch.	The skew setting value should be between -5 and +5. If not, readjust the skew with the printhead mechanical setting. See “Printhead alignment” on page 4-9.
Top margin	-25 to +25 Each increment corresponds to 8 scans at a 600 dpi scan rate (0.0133 inches or 0.339 mm).	A positive change moves the image down the page and increases the top margin. A negative change moves the image up and decreases the top margin.
Bottom margin	-25 to +25 Each increment causes approximately 0.55 mm shift in the bottom margin.	A positive offset moves text up the page and widens the bottom margin. A negative offset moves text down the page and narrows the bottom margin. Note: Make sure the media size selected matches the media size in tray 1.
Left margin	-50 to +50 Each increment corresponds to 4 pels at 600 dpi (0.00666 in. or 0.1693 mm).	A positive change moves the image to the right. A negative change moves the image to the left. The image is compressed or expanded. Note: Make sure the media size selected matches the media size in tray 1.
Right margin	-50 to +50 Each increment corresponds to an approximate shift of 4 pels at 600 dpi.	A positive change moves the image to the right. A negative change moves the image to the left.

5. Touch **Submit** to enter the values.
6. Print the Quick Test to verify your changes
7. Continue changing the settings by repeating steps 2 through 4.

Quick Test

The Quick Test contains the following information:

- Print registration settings
- Alignment diamonds at the left, right, top and bottom
- Horizontal lines to check for skew
- General printer information, including current page count, installed memory, serial number, and code level.

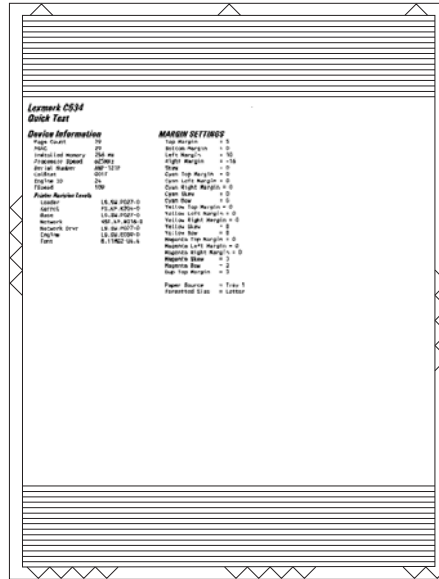

To print the Quick Test page:

Note: Print the Quick Test Page on letter or A4 paper.

1. Touch **Registration** from Diag Menu.
2. Touch **Quick Test**.

The message Quick Test Printing... appears on the display.

Once the Quick Test Page completes printing, the Registration menu displays again.

Scanner Tests

ASIC Test

This test initiates a scan of the scanner ASIC memory.



1. Touch **SCANNER TESTS** in Diag Menu.
2. Touch **ASIC Test**.

The results will be displayed as either ASIC Test Passed or ASIC Test Failed.

To clear the results, press **Stop** ().

Feed Test

The feed test scans and feeds continuously from either the ADF or the flatbed, depending on whether or not paper is placed in the ADF.

1. Touch **SCANNER TESTS** in Diag Menu.
2. Touch **Feed Test**.
3. Indicate the specific media size with  or , and then touch **Start**.

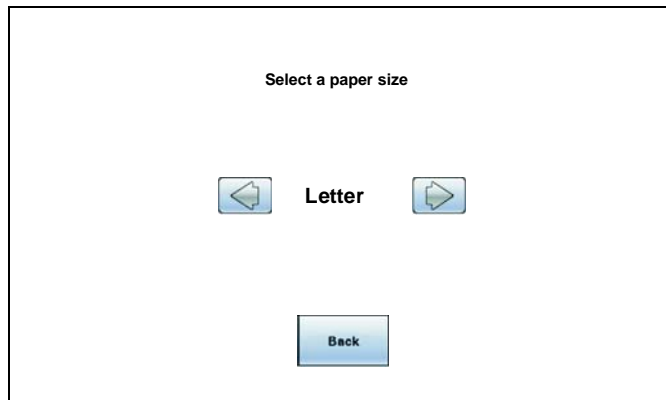

- If media is in the ADF, then ADF feed tests are performed.
 - If no media is in the ADF or the media is exhausted, then the entire flatbed will be scanned
4. Running... Flatbed:0 ADF:0 displays and the number of successful scans is displayed by incrementing the number beside the scan type.
If a failure occurs, Feed Test Failed Flatbed:xxxxx ADF:xxxxx. is displayed showing the number of failure of each scan type.
 5. Press **Stop** () to end the test and clear the messages.

Sensor Tests

Tests to evaluate the scanner sensors in the ADF and the flatbed (FB).

To view the sensor states:

1. Touch **SCANNER TESTS** in Diag Menu.
2. Touch **Sensor Test**.

A screen similar to the one below will display.

ADF Paper Present	0
FB Cover Open	0
Home Sensor	1
Skew Sensor	0
ADF Cover Sensor	0
ADF Exit Sensor	0
Scan Sensor	0
Jam Sensor	1
Paper FB Short	0
Paper FB Medium	0
Paper FB Long	0
Paper ADFF Short	0
Paper ADF Width 1	0
Paper ADF Width 2	0

The meaning of the states is listed in the table below:

Sensor Test descriptions (under Scanner Tests)

Sensor	State	Description
ADF Paper Present	0	Paper not present in ADF
	1	Paper present in ADF
FB Cover Open	0	Flatbed cover closed
	1	Flatbed cover open
Home Sensor	0	Scanner carriage not positioned over home sensor
	1	Scanner carriage positioned over home sensor
Skew Sensor	0	Paper not positioned over the ADF interval sensor
	1	Paper positioned over the ADF interval sensor
ADF Cover Open	0	ADF cover closed
	1	ADF cover open
ADF Exit Sensor	0	Paper not positioned over the ADF exit sensor
	1	Paper positioned over the ADF exit sensor
Scan Sensor	0	Paper is not present above this sensor
	1	Paper is being fed from the ADF, and the top edge passes over this sensor
Jam Sensor1	0	Paper is not present above this sensor
	1	Paper is being fed from the ADF, and the top edge passes over this sensor
Paper FB Short	0	Executive paper is not present on the flatbed or the scanner cover is not closed
	1	Executive paper is present on the flatbed, is covering the first length sensor, and the scanner cover is closed
Paper FB Medium	0	Letter paper is not present on the flatbed or the scanner cover is not closed
	1	Letter paper is present on the flatbed, is covering the second length sensor, and the scanner cover is closed

Sensor Test descriptions (under Scanner Tests)

Sensor	State	Description
Paper FB Long	0	Legal paper is not present on the flatbed, or the scanner is not closed
	1	Legal paper is present on the flatbed, is covering the third length sensor, and the scanner cover is closed
Paper ADF Long	0	Paper not present in the ADF, or positioned over the ADF bin sensor
	1	Paper present in the ADF, and positioned over the ADF bin sensor.
Paper ADF Width 1	0	Paper present in the ADF, and the paper edge guide is moved to the Executive position
	1	Paper is not present in the ADF, or the paper edge guide is not positioned in the Executive position
Paper ADF Width 2	0	Paper present in the ADF, and the paper edge guide is moved to the Executive position
	1	Paper is not present in the ADF, or the paper edge guide is not position in the Executive position

Press **Stop** () to return to the Scanner Tests Menu.

Alignment Menu

Note: If you need to perform alignment or registration, see **“Printhead alignment” on page 4-9.**

The following information is meant to explain the uses for the menu items.

Alignment is part of the process of adjusting the printhead and the color planes to the black plane and to each other. Before you start, perform the black alignment (Registration). See **“Printhead alignment” on page 4-9.** If you are replacing a new printhead, see **“Printhead removal, installation, and adjustment” on page 4-128.**

To perform alignment:

1. Touch **ALIGNMENT MENU** from Diag Menu.
2. Select one of the colors; cyan, yellow, or magenta.
3. Touch the arrows next to the settings, and then set the values to zero.

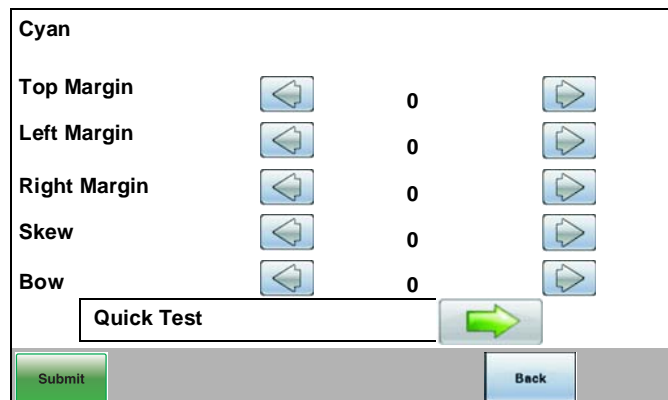

4. Continue for all colors; cyan, yellow, and magenta.
5. Touch **Submit**.
Note: It is important to zero out all settings to make the adjustment easier.
6. Touch **Quick Test**
Quick Test printing... is displayed, and then two pages print.
7. On the pages, make sure all the Current Values are set to zero. If not, go back to step 2 and repeat.

8. Look at the coarse and fine adjustments on the top left of the page, and then enter the best number for the top adjustment in the T space. Transfer this number over to the computation area for Z.
9. On the touch panel, select **Top Margin**. Use ◀ to decrease or ▶ to increase the computed value for T, and then touch **Submit**.
10. Repeat this process for skew (Z). Add the T value and the current Z value to obtain the new skew (Z) value.
Reprint the Quick Test page after each change, and then observe the results. Make additional adjustments if necessary before proceeding on to Quick Test step two page.
11. Obtain left (L), right (R), and Bow (P) value using the same method as obtaining T from Quick Test Step 1. Reprint the Quick Test to ensure the settings are correct. Make additional adjustments as required.
12. Press **Back** to return to ALIGNMENT Menu.

See **“Printhead mechanical alignment” on page 4-9** for printout samples and additional information.

Motor tests

The motor tests are run primarily to locate noises in the printer.

General motor tests procedures

In some instances, when you enter a particular test, you will be given the choice to run the motor in forward or reverse. Other times, there will only be the option to run the motor in forward direction.

In general, the test should work as follows:

1. Touch **MOTOR TESTS** from Diag Menu.
2. Select the motor that you need to test.
3. Check the table below for setup requirements, if any.
4. Select the direction if a choice is offered (**Forward** or **Reverse**) or other setting for that test.

Press **Stop** () to stop the motor. Touch **Back** to return to the previous menu.

The following tests require special setup before running the test (not shown in the same order as the menu):

Motor test	Setup requirements		Values in menu	Notes
	Top cover position	Lower door position		
Align Motor Test	N/A	Closed*	Forward, Reverse	*If this test is run with the lower door open, perform the following actions in order to activate the motor power: Remove the right side cover and manually activate the 24 V interlock switch on the end of the top cover cam shaft and the 5 V interlock switch.
Fuser	Closed	Closed*	Forward, Reverse	
Cart 1	N/A	Open	Forward	Remove the right cover to observe the motors moving. See “Right cover removal” on page 4-39 .
Cart 2	N/A	Open	Forward	
Cart 3	N/A	Open	Forward	
Transfer Belt	Closed	Closed	Touch green arrow	
Tray 1	Not applicable	Not applicable	Forward	Remove all paper from the input source tray to avoid paper jams while performing this test.

Motor test	Setup requirements		Values in menu	Notes
	Top cover position	Lower door position		
MPF	Not applicable	Closed*	Reverse	Multipurpose feeder—Remove the optional tray to avoid paper jams while performing this test. *If this test is run with the lower door open, perform the following actions in order to activate the motor power: Remove the right side cover and manually activate the 24 V interlock switch on the end of the top cover cam shaft and the 5 V interlock switch.
CAM	Not applicable	Closed	Forward, Reverse	
COD	Not applicable	Closed	Forward, Reverse	COD stands for Color on Demand
Duplex	Not applicable	Closed	Forward	
Transfer Belt				

Print Tests

Input source tests

The purpose of the diagnostic Print Tests is to verify that the printer can print on media from each of the installed input options. The contents of the Print Test Page varies depending on the media installed in the selected input source.



Check each Test Page from each source to assist in print quality and paper feed problems.

To run the Print Test Page:

1. Touch **PRINT TESTS** from the Diag Menu.
2. Select the media source by touching the green arrow next to one of the items below:

- Tray 1
- Tray 2 (if installed)
- Tray 3 (if installed)
- Tray 4 (if installed)
- Tray 5 (if installed)
- Multi-Purpose Feeder (if installed)
- Print Quality Pages

Only installed trays will appear on the display.

3. Select either **Single** or **Continuous**.

- If **Single** is selected, a single page is printed.
- If **Continuous** is selected, printing continues until **Stop** () is pressed to cancel the test.
If a source is selected that contains envelopes, an envelope test pattern is printed. If Continuous is selected, the test pattern is printed only on the first envelope.

Note: The Print Test Page always prints on one side of the paper, regardless of the duplex setting.

Print quality test pages (Prt Quality Pgs)

The print quality test consists of five pages. Pages one and two contain a mixture of graphics and text. The remainder of the pages only contain graphics. The test prints on the media in the default tray.

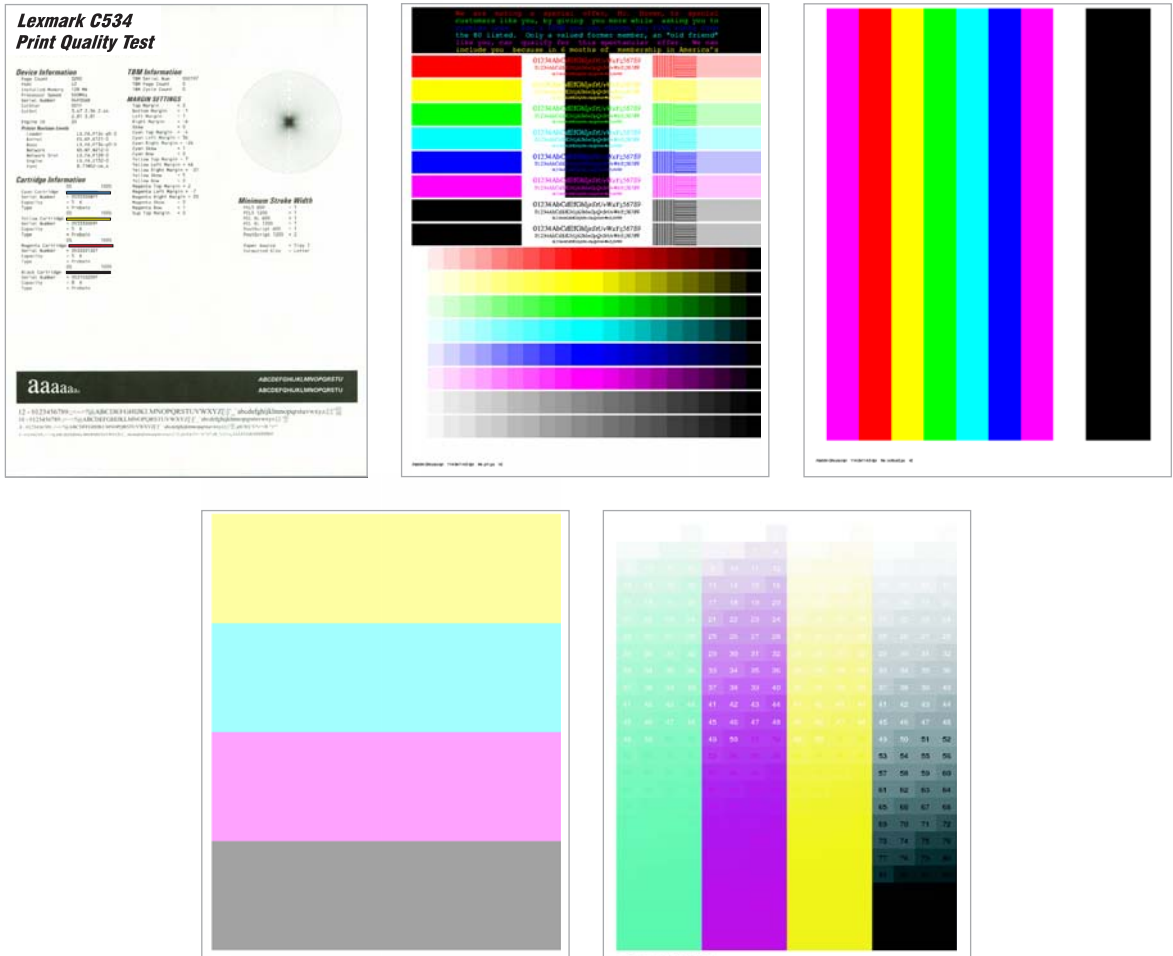

This test may be printed from either Configuration Menu or the Diagnostics Menu. To run the print quality pages from the Diagnostics mode, select **PRINT TESTS** and **Print Quality Pgs** from the menu. Once the test is started, it cannot be canceled. When the test pages print, the printer returns to the original screen.

To run the Print Quality Test Pages, select **Prt Quality Pgs** from PRINT TESTS, and then touch **Back**. The message Printing Quality Test Pages is displayed, and the test prints.

Hardware Tests

Panel Test

This test verifies the operator panel LCD function.

To run the Panel Test:

1. Touch **HARDWARE TESTS** from Diag Menu.
2. Touch **Panel Test**.
The Panel Test continually executes. Each pixel is activated at the darkest level to the lightest level, and then the backlight illuminates and turns off. This is repeated continuously.
3. Press **Stop** () to cancel the test at any point.

Button Test

This test verifies the operator panel button function.

To run the Button Test:

1. Touch **HARDWARE TESTS** from Diag. Menu.
2. Touch **Button Test**.
3. Press each button on the operator panel. The corresponding button on the diagram changes color and *beeps*.

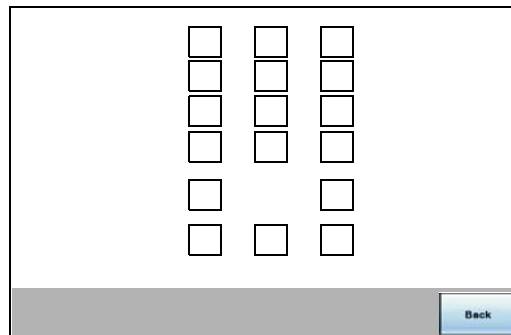

Touch **Back** to end the test.

DRAM Test

This test checks the validity of DRAM, both standard and optional. The test writes patterns of data to DRAM to verify that each bit in memory can be set and read correctly.

To run the DRAM Test:

1. Touch **DRAM Test** from **HARDWARE TESTS** in Diag.
2. The MFP turns off and re-starts (POR), and then the power indicator *blinks*, indicating the test is in progress.

The following counter appears:

```
DRAM Test  xxxMB  P:000000  F:0000
```

To interpret the test:

- xxxMB indicates the amount of DRAM memory the MFP has detected.
- P:##### represents the number of times the memory test has passed and finished successfully. Initially, 000000 displays with the maximum pass count being 99,999.
- F:##### represents the number of times the memory test has failed and finished with errors. Initially, 00000 displays with the maximum fail count being 99,999.

Once the maximum pass count or fail count is reached, the test is stopped, the power indicator turns on solid, and then the final results appear. If the test fails, SDRAM Error appears for approximately three seconds and the failure count increases by 1.

Note: If you need to exit the test before it is complete, turn off the printer.

Serial 1 Wrap

The Serial 1 Wrap Test is used to check the operation of the serial port hardware using a wrap plug. Each serial signal is tested.

To perform the Serial 1Wrap Test:

1. Disconnect the serial interface cable, and then install the serial wrap plug.
2. Touch **HARDWARE TESTS** from the Diag Menu.
3. Touch **Serial 1 Wrap**.

The power indicator *blinks* indicating the test is in progress. The following messages appear

```
Serial Wrap [x] Testing...
```

```
Resetting the Printer
```

Upon completion of the POR, the following message is displayed:

```
Serial Wrap  P:000000  F:0000
```

4. The test will stop when it reaches the maximum values, or press **Stop** () to end the test before it is complete.

To interpret the test:

P:##### represents the number of times the serial port hardware has passed.

Initially, 000000 is displayed. The maximum pass count is 999,999.

F:##### represents the number of times the serial port hardware has failed.

Initially, 0000 is displayed. The maximum fail count is 999,999.

Any of the following explanations for a serial wrap test failure may display:

- Receive Status Interrupt Error
- Status Error
- Receive Data Interrupt Error
- Transmit Data Interrupt Error
- Transmit Empty Error
- Threshold Error
- Receive Data Ready Error
- Break Interrupt Error
- Framing Error
- Parity Error
- Overrun Error
- Data Error
- Data 232 Error
- Data 422 Error
- FIFO Error
- DSR Error
- DSR PIO Error
- DSR Interrupt Error
- CTS Error
- CTS PIO Error
- CTS Interrupt Error

USB HS Test Mode

1. Touch **HARDWARE TESTS** from Diag Menu
2. Touch **USB HS Test Mode**.

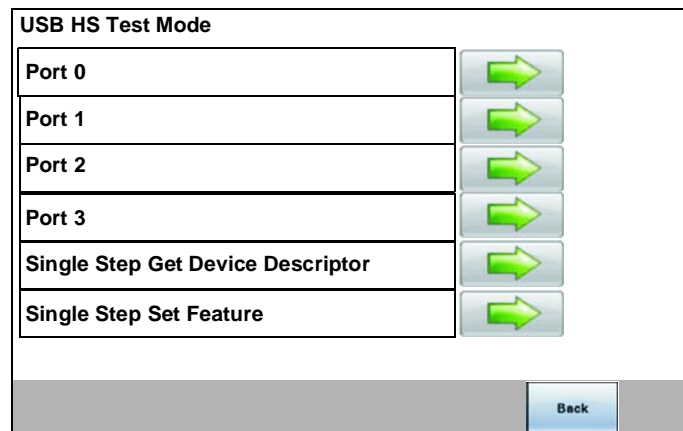

3. Select the port you want to test.
 - Port 0
 - Port 1
 - Port 2
 - Port 3
4. Select the test for the port you chose:
 - Test J
 - Test K
 - Test SE0 NAK
 - Test Packet
 - Test Force Enable

While the test executes, USB High Speed Testing... displays.

To exit the test, restart the printer.

Print Test (duplex)

This test provides service personnel with a way to verify the function of the printer's duplex hardware. After the user selects this test, the device automatically executes a continuous print test that generates a duplexed, color output page. To stop the test, the user must press **Stop** (). While this test executes, the power indicator light blinks green and the panel displays “DUPLEX TESTS Printing...”.



The paper you choose to print the page on should be either Letter or A4.

To run the Print Test (duplex):

1. Touch **DUPLEX TEST** in the Diag Menu.
2. Touch **Print Test**.
The printer executes a continuous print test that generates a duplexed, color output page.
3. To stop the test, press **Stop** ().

Top Margin (duplex)

This setting controls the offset between the first scan line on the front of the duplex page and the first scan line on the back of the page. Therefore, be sure to set the top margin in REGISTRATION before setting the duplex top margin. See **“Registration” on page 3-6**.

To set the Top Margin (duplex):

1. Touch **DUPLEX TESTS** in the Diag Menu.
2. Touch **Quick Test**.
3. Touch **Single**.
The test page prints.
4. Hold the page to the light to see whether the top margin of the back aligns with the top margin of the front.
5. If they do not match, select **Top Margin**.
6. Use ◀ or ▶ to select the margin setting you need to change.
 - Each increment shifts the duplex top margin by 1/100 of an inch.
 - The Top Margin (duplex) range is -25 to +25, and the default value is 0.
 - An increase moves the top margin down and widens the top margin. A decrease moves the top margin upward and narrows the top margin.
7. Touch **Submit**.
8. Print the Quick Test again to verify the adjustment. Repeat until the front and back top scan lines match.

Left Margin (duplex)

By modifying this setting you can shift the image on the back side of a duplex page to the right or to the left.

To set the Left Margin (duplex):

1. Select **DUPLEX TESTS** in the Diagnostics Menu, and then press **Select** ().
2. Select **Quick Test**, and then press **Select** ().
3. Select **Single**, and then press **Select** ().
The test page prints.
4. Hold the page to the light to see whether the left margin of the back aligns with the left margin of the front.
5. If they do not match, Touch **Left Margin**.
6. Use ◀ or ▶ to select the margin setting you need to change.
 - Each increment shifts the duplex left margin by 4 pixels at 600 dpi (0.00666 inches or 0.1693 mm).
 - The Left Margin range is -50 to +50, and the default value is 0.
 - An increase moves the margin to the right, and a decrease moves the margin to the left.

Skew (duplex)

This setting adjusts the duplex motor speed when it feeds through the aligning roll. It controls the skew between the first scan line and the top of the page. Adjustments are made to the image that is face down in the output tray.

Sensor Tests

There are two groups of sensors tests, static sensors and dynamic sensors.

To run the Sensor Test:

1. Touch **SENSOR TESTS** in Daig Menu.
2. Select either **Static Sensors** or **Dynamic Sensors**.

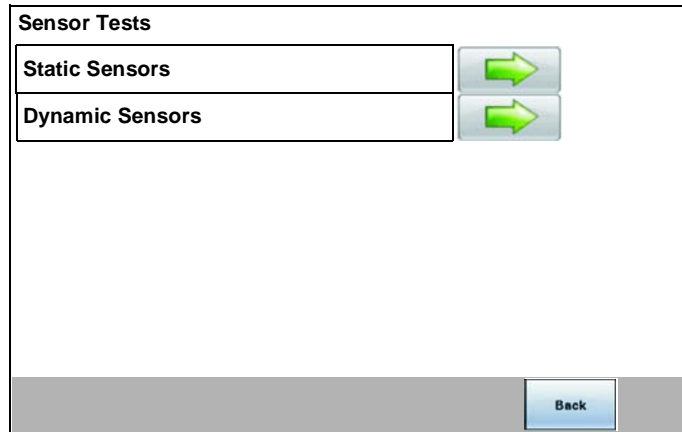

- For static sensors—view the current status. Exit menus and enter the menus again to change the state.
- For dynamic sensors—view the current status and toggle the state to test the sensor.

Press **Stop** () to exit a test.

Sensors

Sensor type	Sensor name	Possible values	Sensor activation
Static sensors	Waste Toner	Empty, Full, or Missing	N/A
	Belt Waste	Empty or percentage full	N/A
	Fuser Temp	Degrees (C)	N/A
	BUR Temp	Degrees (C)	N/A
	Power	Voltage	N/A
Dynamic sensors	Fuser Exit	Open/Closed	Open the top access cover. Activate the fuser exit flag. The sensor should change state.
	Input	Open/Closed	Remove the paper tray 1. Activate the input sensor flag. The sensor should change state.
	Front Door	Open/Closed	Open the front door. The sensor should change state.
	Top Door	Open/Closed	Open the top access cover assembly. The sensor should change state.
	Narrow Media	Open/Closed	Test the MP feeder tray by inserting a sheet of paper, and then pushing up to sensor. The sensor should change state.
	K Toner	Open/Closed	Remove the black toner cartridge. Shine a flashlight on the toner level sensor. The sensor should change state.

Sensors (continued)

Sensor type	Sensor name	Possible values	Sensor activation
Dynamic sensors (continued)	M Toner	Open/Closed	Remove the magenta toner cartridge. Shine a flashlight on the toner level sensor. The sensor should change state.
	C Toner	Open/Closed	Remove the cyan toner cartridge. Shine a flashlight on the toner level sensor. The sensor should change state.
	Y Toner	Open/Closed	Remove the yellow toner cartridge. Shine a flashlight on the toner level sensor. The sensor should change state.
	TPS (toner patch sensor)	Open/Closed	Open the front access door. Slip a piece of paper between the TPS and the transfer module. The sensor should change state.
	Bubble	Open/Closed	Open the front door. Activate the fuser entry flag. The sensor should change state.

Printhead Tests**Mirror Motor Test**

1. Touch **PRINTHEAD TESTS** in Diag Menu.
2. Touch **Mirror Motor Test**.
The panel displays Mirror Motor Test–Motor Running...
After the test completes, the panel displays either Pass or Fail.

To stop the test, press **Stop** ().

Servo Laser Test

1. Touch **PRINTHEAD TESTS** in the Diag Menu.
2. Touch **Servo Laser Test**.
The panel displays Servo Laser Test–Motor Running... After the test completes, the panel displays either Pass or Fail.

To stop the test, press **Stop** ().

Device Tests

These tests only appear if the flash or disk option is installed.

Quick Disk Test

This test performs a non-destructive read/write on one block per track on the disk. The test reads one block on each track, saves the data, and then proceeds to write and read four test patterns to the bytes in the block. If the block is good, the saved data is written back to the disk.

To run the Quick Disk Test:



1. Touch **DEVICE TESTS** in Diag Menu.
2. Touch **Quick Disk Test**.
 - The power indicator *blinks* while the test is in progress.
 - Quick Disk Test/Test Passed is displayed if the test passes and the power indicator turns on solid.
 - Quick Disk Test/Test Failed is displayed if the test failed and the power indicator turns on solid.

You cannot stop the test while it is running, but when it is complete, press **Stop** () to return to DEVICE TESTS.

Disk Test/Clean

Warning: This test destroys all data on the disk and should not be attempted on a good disk. This test may run approximately 1½ hours depending on the disk size.

To run the Disk Test/Clean Test:

1. Touch **DEVICE TESTS** in the Daig Menu.
2. Touch **Disk Test/Clean**.
Files will be lost/Go or Stop? is displayed to warn the user.
3. To exit the test immediately and return to DEVICE TESTS, press **Stop** (). To continue with the test, touch **Continue**.
If is selected, Disk Test/Clean/BAD:000000 00% is displayed. The screen updates periodically, indicating the percentage of test completed and the number of bad blocks found.
4. The power indicator *blinks* during the test. The test can be canceled at any time during the test by pressing **Stop** ().
Once the test is complete, the power indicator turns on solid and a message displays.

To interpret the test:

- xxxx Bad Blocks/yyyyy Usable is displayed if fewer than 2000 bad blocks are detected. xxxx indicates the number of bad blocks, and yyyyyy indicates the number of usable blocks.
- xxxx Bad Blocks/Replace Disk is displayed if more than 2000 bad blocks are detected. The disk cannot be recovered because too many bad blocks exist on the disk.

Press **Stop** () to return to DEVICE TESTS.

Flash Test

This test causes the file system to write and read data on the flash to test the flash.

Warning: This test destroys all data on the flash because the flash is reformatted at the end of the test.

To run the Flash Test:

1. Touch **DEVICE TESTS** in the Diag Menu.
2. Touch **Flash Test**.
 - The power indicator *blinks* while the test is running.
 - Flash Test/Test Passed is displayed if the test passes and the power indicator turns on solid.
 - Flash Test/Test Failed is displayed if the test fails and the power indicator turns on solid.

Press **Stop** () to return to DEVICE TESTS.

Printer Setup

Defaults

U.S./Non-U.S. defaults changes whether the printer uses the U.S. factory defaults or the non-U.S. factory defaults. The settings affected include paper size, envelope size, PCL symbol set, code pages, and units of measure.

Warning: Changing this setting resets the printer to factory defaults, and data may be lost. It cannot be undone.

To change the Defaults:

1. Touch **PRINTER SETUP** in Diag Menu.
2. Touch **Defaults**.
3. Select from U.S. or Non-U.S., and then touch **Submit**.

Page Counts

You can view, but not change any of the three counts displayed under PAGE COUNTS.

To view the Prt Color Pg Count, the Prt Mono Pg Count, or the Perm Page Count:

1. Touch **PRINTER SETUP** in Diag Menu.
2. The Printer Color Pg Count, Prt Mono Pg Count, and then the Perm Page Count are displayed.

Touch Back to return to Diag Menu.

Serial Number

The serial number can only be viewed and cannot be changed.

To view or change the serial number:

1. Touch **PRINTER SETUP** in the Diag Menu.
2. To change the value, touch the keyboard icon.
A simulation of a typewriter allows you to enter an alphanumeric value.
3. Touch **Submit** to save the value or Back to exit without saving.

Press **Stop** () to return to PRINTER SETUP.

Engine Setting 1 through 4

Warning: Do not change these settings unless requested to do so by your next level of support.

Model Name

The model name can only be viewed and cannot be changed.

To change the model name:

1. Touch **PRINTER SETUP** in the Diag Menu.
2. To change the Model Name, touch **the right or left arrows**.
3. Touch **Submit** to save the value or Back to exit without saving.

Configuration ID

The two configuration IDs are used to communicate information about certain areas of the printer that cannot be determined using hardware sensors. The configuration IDs are originally set at the factory when the printer is manufactured. However, the servicer may need to reset Configuration ID 1 or Configuration ID 2 whenever the system board is replaced. The IDs consist of eight digits. The first seven digits in each ID are hexadecimal numbers, while the last digit is a checksum of the preceding seven digits. Each ID can contain a combination of the digits 0 through 9, and A through F.

Note: When the printer detects a Configuration ID that is not defined or invalid, the following occurs:

- The default standard model Configuration ID is used instead.
- Configuration ID is the only function available in DIAGNOSTICS.
- Unless the menu is in DIAGNOSTICS, Check Config ID displays.

To set the configuration ID:

1. Touch **PRINTER SETUP** from the Diag Menu.
2. Touch **Configuration ID keyboard icon**.
The values for Configuration ID 1 and Configuration 2 are displayed.

The screenshot shows the 'PRINTER SETUP' screen. At the top, there is a title 'PRINTER SETUP' and a back arrow icon. Below the title, there is a 'Configuration ID' section with two input fields: 'ID1: XX XX XX XX' and 'ID2: XX XX XX XX'. Underneath these fields are two buttons: 'Reset Color Cal' and 'Motor Calibration', each with a right-pointing arrow icon. At the bottom of the screen, there is a 'Submit' button on the left and an 'Exit Diag Menu' button on the right. There are also up and down arrow icons on the right side of the screen for navigation.

- Use ◀ or ▶ to move from one position to another in the Configuration number(s)
 - Touch 0 through 9 and/or A through F to input numbers.
 - Touch rounded back arrow to erase numbers.
3. Touch **Submit**.
 4. Enter the Configuration ID 1.
 - To select a digit or character to change, press ◀ or ▶ until the digit or character is underlined.
 - To change a digit or character, press ▲ to increase or ▼ to decrease the value.
 - When the last digit is changed, touch **Submit** to validate the Configuration ID 1.
If **Invalid ID** appears, the entry is discarded, and the previous Configuration ID 1 is displayed on the screen.
If the process is successful, **Submitting Selection** appears on the display, followed by the current value for Configuration ID 2.
 5. Repeat the steps for entering the Configuration ID, and then touch **Submit**.
If the Configuration ID 2 is validated, **Submitting Selection** appears, and then a check (✓) appears next to **Printer Setup**.

Note: The printer will NOT perform an automatic POR after the Configuration IDs are accepted.

Reset color calibration (Reset Color Cal)

The Reset Color Cal enables the alignment of the color planes using pre-programmed values. Automatic Color Adjust Calibration may be more effective.

1. Touch **PRINTER SETUP** in the Diag Menu.
2. Touch **Reset Color Cal**.
Resetting displays.

Parallel 1 strobe adjustment (Par 1 Strobe Adj)

Note: This setting only appears if the printer has a parallel port available in the PCI slot 1.

This setting enables the servicer to adjust the amount of time the strobe is sampled in order to determine if valid data is available on the parallel port. The range of values is -4 to 6. Each time this value is incremented by 1, the strobe is sampled 50 ns (nanoseconds) longer. Each time this value is decreased by 1, the strobe is sampled 50 ns less often. When the value of this setting is 0, the factory default is used to determine the length of time the strobe is sampled. If the servicer, for example, decreased the value from 0 to 3, the strobe will be sampled for 150 ns longer than the factory setting.

Motor Calibration

This setting synchronizes the aligner and fuser motor speeds with the transfer belt speed to ensure that the output is printed correctly.

To perform a Motor Calibration:

1. Touch **PRINTER SETUP** in the Diag Menu.
2. Touch **Motor Calibration**.
3. Touch **Motor Calibration** on the next screen.
Calibrating... is displayed, and then eight blank pages are produced.

Press Back to return to PRINTER SETUP.

Cal Ref Adj

To adjust the Cal Ref Adj:

1. Touch **PRINTER SETUP** in the Diag Menu.
2. Touch the arrows beside Cal Ref Adj to increase or decrease the value.
3. Touch **Submit**.

EP Setup

EP Defaults

This setting is used to restore each printer setting listed in EP SETUP to its factory default value. Sometimes this is used to help correct print quality problems.

To restore EP Defaults:

1. Touch **EP SETUP** from Diag Menu.
2. Touch **EP Defaults**.
3. Select either Restore or Do Not Restore.
 - Touch **Restore** to reset the values to the factory settings
Restoring Factory Defaults is displayed.
 - Touch **Do Not Restore** to exit without changing the settings.

Fuser temperature (Fuser Temp)

This adjustment can be used to help solve some customer problems with paper curl on low grade papers and problems with letterheads on some types of media.

To adjust the fuser temperature:

1. Touch **EP SETUP** from Diag Menu.
2. Touch the left or right arrows beside Fuser Temp to toggle between **Low**, **Normal**, or **High**.
The default is Normal.
3. Touch **Submit**.

DC Charge Adjust, Dev Bias Adj, Transfer Adjust

Each of these three settings enables you to adjust the high voltage levels controlling the electrophotographic process. You will use these settings to compensate for unusual operating circumstances such as high humidity. The printer uses the value of these settings together with other settings to calculate printing speed and media selection.

To adjust DC Charge Adjust:

1. Touch **EP SETUP** from Diag Menu.
2. Touch the left or right arrows beside DC Charge Adjust to toggle between Low, Normal, or High.
The default is Normal.
3. Touch **Submit**.

To Adjust Dev Bias Adj or Transfer Adjust:

1. Touch **EP SETUP** from Diag Menu.
2. Touch **Adjust Dev Bias Adj** or **Transfer Adjust** (these menu items work similarly).
Four choices appear:
Black
Magenta
Cyan
Yellow
3. Touch the left or right arrows beside the setting or settings you want to change.
Select Low, Normal, or High. The default is Normal.
4. Touch **Submit**.

Reports

Menu Settings Page

The Menu Settings Page is a list of Diag Menu settings with the current value.

To print the Menu Settings Page:

1. Touch **REPORTS** in the Diag Menu.
2. Touch **Menu Settings Page**.
The following displays and the page or pages print.
Printing...
Menu Settings Page

Touch **Back** to return to the Diag Menu.

Clear Log

Use Clear Log to remove the current information in the Event Log. This affects both the viewed log and the printed log information.

1. Touch **EVENT LOG** in Diag Menu.
2. Touch **Clear Log**.
3. Touch **YES** to clear the Event Log or touch **NO** to exit the Clear Log menu.
If **YES** is selected, Deleting EVENT LOG displays on the screen.

Press **Back** to return to EVENT LOG.

EXIT DIAGNOSTICS

Touch **Exit Diag Menu**. The printer performs a power-on reset and returns to normal mode.

Configuration menu (CONFIG MENU)

Available tests

The tests display on the operator panel in the order shown. Not all menus appear, depending upon the configuration of your multiple function printer. For example, if you do not have a hard disk installed, then Disk Encryption and Wipe Disk will not appear.

Reset Fuser Counter	See “Reset Fuser Count” on page 3-31.
USB Scan to Local	See “USB Scan to Local” on page 3-31.
Color Lock Out	See “Color Lock Out” on page 3-32.
Print Quality Pages	See “Prt Quality Pages” on page 3-32.
Reports	
Menu Settings Page	See “Menu Settings Page” on page 3-32.
Event Log	See “Event Log” on page 3-33,
Color Trapping	See “Color Trapping” on page 3-33.
SIZE SENSING	See “Size Sensing” on page 3-33.
Panel Menus	See “Panel Menus” on page 3-34.
PPDS Emulation	See “PPDS Emulation” on page 3-34.
Factory Defaults	See “Factory Defaults” on page 3-35.
Energy Conserve	See “Energy Conserve” on page 3-35.
Numpad Job Assist	See “NumPad Job Assist” on page 3-36.
Min Copy Memory	See “Min Copy Memory” on page 3-36.
Format Fax Storage	See “Format Fax Storage” on page 3-36.
Fax Storage Location	See “Fax Storage Location” on page 3-37.
ADF Edge Erase	See “ADF Edge Erase” on page 3-37.
FB Edge Erase	See “FB Edge Erase” on page 3-37.
Scanner Manual Registration	See “Scanner Manual Registration” on page 3-38.
Disable Scanner	See “Disable Scanner” on page 3-40.
Automatic Color Adjust	See “Automatic Color Adjust” on page 3-40.
Auto Align Adj	See “Auto Align Adj” on page 3-40.
Enforce Color Order	See “Enforce Color Order” on page 3-41.
Color Alignment	See “Color Alignment” on page 3-41.
Color Adj State	See “Color Adj State” on page 3-41.
Motor Calibration	See “Motor Calibration” on page 3-42.
Paper Prompts	See “Paper Prompts” on page 3-42.
Envelope Prompts	See “Envelope Prompts” on page 3-42.
Action for Prompts	See “Action for Prompts” on page 3-43.
Jobs on Disk (if hard disk is installed)	See “Jobs on Disk” on page 3-43.
Disk Encryption (if hard disk is installed)	See “Disk Encryption” on page 3-44.
Wipe Disk (if hard disk is installed)	See “Wipe Disk” on page 3-45.
Duplex Gloss	See “Duplex Gloss” on page 3-43.
Font Sharpening	See “Font Sharpening” on page 3-46.

Require Standby	See “Require Standby” on page 3-46.
LES Applications	See “LES Applications” on page 3-46.
Key Repeat Initial Delay	See “Key Repeat Initial Delay” on page 3-46.
Key Repeat Rate	See “Key Repeat Rate” on page 3-46.
Clear Custom Status	See “Pel Blurring” on page 3-47.
Pel Blurring	See “Pel Blurring” on page 3-47.
USB Speed	See “USB Speed” on page 3-47.
Exit Config Menu	This selection exits Configuration Menu, and then Resetting the Printer displays. The printer performs a POR and returns to normal mode.

Reset Fuser Count

Resets the fuser count value to zero. The Event Log records each time that a user executes the Reset Fuser Count operation. See **“Event Log”** on page 3-33 for more information. This setting only appears if the Maintenance Warning and Intervention function is enabled in the printer Configuration ID.

To reset the fuser count:

1. Touch **Reset Fuser Counter** from the Config Menu.
2. Touch **Reset Fuser Counter** again.

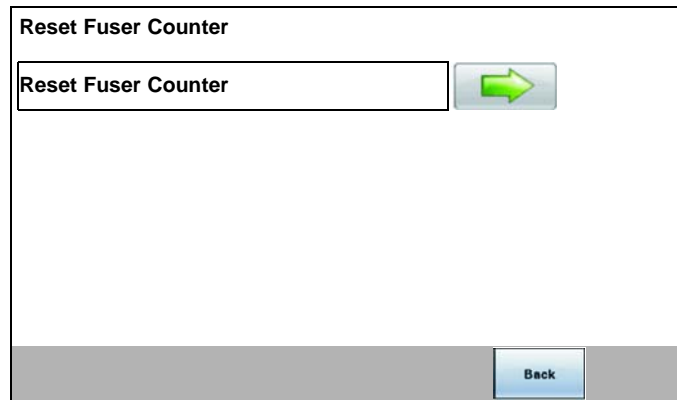

You are returned to the Config Menu.

USB Scan to Local

This setting allows you to limit or expand the uses for the USB device on the front of the multiple function printer. If you select **On** (the default), the contents of the USB device can be viewed or saved on another device, such as an USB-connected computer. If you select **Off**, only the MFP can view the USB device contents.

To change the setting:

1. Touch **USB Scan to Local** from the Config Menu.
2. Touch the left or right arrows to select either **Off** or **On**.
3. Touch **Submit**.

Touch **Back** to return to the Config Menu screen.

Color Lock Out

Select **On** when printing for extended periods with only black toner. This saves the color toner cartridges (cyan, magenta, and yellow) and photoconductor units from excessive wear. In addition to setting the values, the cyan, magenta, and, yellow toner cartridges and their matching photoconductor units must be removed from the printer. The default value is **Off**.

To initiate Color Lock Out:

1. Touch **Color Lock Out** from the Config Menu.
2. Touch the left or right arrows to select **On**.
3. Touch **Submit**.
Submitting Changes... is displayed.
4. Remove all color cartridges and color photoconductor units (cyan, yellow, and magenta). Leave the black supplies only.
5. Turn the MFP off, and then on (POR).
Note: If the color supplies are left installed when the MFP returns to the normal menus, the MFP displays Remove All Color Supplies.

Note: When you turn Color Lock Out Off (the default mode) after it has been On, at the next POR to normal mode the printer will display 31 Missing or Defective *<color>* Cartridge. Replace the color cartridges and color photoconductors.

Prt Quality Pages

To help isolate print quality problems, print the Print Quality Test Pages. The pages are formatted. The Printing Quality Test Pages message appears, then the pages print. The message remains on the operator panel until all the pages print.

To print the Print Quality Pages:

1. Touch **Print Quality Pages** in Config Menu.
2. Touch **Print Quality Pages** again.

Touch Back to return to the Config Menu.

The Print Quality Test Pages contain several pages. The first page which is a mixture of text and graphics. The information includes values of the Quality Menu settings in Settings and printer and toner cartridge configuration information. The remaining pages only contain graphics. For samples of the pages, see **“Print quality test pages (Prt Quality Pgs)” on page 3-14**.

Reports

Menu Settings Page

The Menu Settings Page generates a list of Configuration Menu settings and the current values.

To print the Menu Settings Page:

1. Touch **Reports** in Config Menu.
2. Touch **Menu Settings Page**.
Printing Menu Settings Page... is displayed. A set of the Configuration Menu settings is printed.

Event Log

This menu item lets the system support person print a limited set of the information contained in the Diagnostics mode version of the printed Event Log. For a sample of a Diagnostics Menu Event Log printout, see “**Event Log**” on page 3-28. The limited Configuration log and the full Diagnostics log printed versions show the same operator panel messages when they print and follow the same layout guidelines.

To print the Event Log:

1. Touch **Reports** from the Config Menu.
2. Touch **Event Log**.
Printing EVENT LOG... is displayed.

Note: If an optional parallel card is supported and installed, then after the Event Log prints, a separate report that details the parallel card's history.

Color Trapping

Uses an algorithm to compensate for mechanical misregistration in the printer. When small black text or fine black lines are being printed, the printer checks to see if they are being printed on top of a colored background. If so, rather than remove the color from beneath the black content, the printer leaves the color around the edge of the text or line. The hole in the colored region is reduced in size which prevents the characteristic white gap that is caused by mis-registration.

This menu item applies to PCL 5e emulation, PCL XL, PDF, and PostScript.

Selections are **Off** and the values **1** through **5**, with **2** as the default. Values 1 through 5 indicate the amount of color remaining beneath the black content. Each setting increments by 1/600 of an inch. The less accurate the registration setting, the higher the setting needs to be adjusted. Selecting **Off** disables color trapping. The default value is 2.

To increase or decrease color trapping:

1. Touch **Color Trapping** from the Config Menu.
2. Touch the left arrow to decrease the color margin or the right arrow increase the color margin.
3. Touch **Submit**.
Submitting changes... is displayed.

You are automatically returned to the Configuration main menu.

Size Sensing

Turns the size sensing **Auto** or **Off** for print media input sources that have the ability to sense media sizes. The default value is Auto.

To select size sensing for a tray that has that feature:

1. Touch **SIZE SENSING** from the Config Menu.
2. Touch **Tray 2, Tray 3, Tray 4, or Tray 5**.
Only those sources which support automatic size sensing are displayed.
3. Select **Auto**.
4. Select **Submit**.

Panel Menus

Lets the system support person lock users from Administrative menus. The Menu icon will not appear on the operator pane Selecting **On** (the default) prevents users from accessing menus. **Off** allows users to access the menus. The default value is set to On. Menus secured by password access are blocked, but the security access settings are retained if Panel Menus is set to On.

This menu item only appears when the PJJ PASSWORD Environment variable is set to 0.

To change the Panel Menus:

1. Touch **Panel Menus** from the Config Menu.
2. Touch the right or left arrow to select Off or On.
3. Select **Submit**.

Submitting changes... is displayed.

You are automatically returned to the Configuration main menu.

PPDS Emulation

Activates or deactivates (default) the Personal Printer Data Stream (PPDS) emulation language. This menu item only appears if the PPDS interpreter is available.

To activate or deactivate PPDS Emulation:

1. Touch **PPDS Emulation** from the Config Menu.
2. Touch the right or left arrow to select **Deactivate** or **Activate**.
3. Select **Submit**.

Deactivating PPDS Mode... or Activating PPDS Mode... is displayed.

You are automatically returned to the Configuration main menu.

Download Emuls

This menu item allows the system support person turn the download emulator off temporarily. This menu item only appears if at least one download emulator is installed.

The only selection is **Disable**. The printer automatically re-enables all download emulators after two instances of a power-on reset for the printer. To re-enable these emulators, a user would perform another power-on reset after exiting the Config Menu.

Factory Defaults

This menu item resets the majority of printer values back to their factory default settings.

Warning: This selection cannot be reversed, so this operation should only be used as a last resort to fix any printer problem.

When factory default settings are restored:

- All downloaded resources (fonts, macros, symbol sets) in the printer memory (RAM) are deleted.
- All menu settings return to the factory default setting *except*:
 - The Display Language setting in the “Setup” Menu.
 - All settings in the Parallel Menu, Serial Menu, Network Menu, Infrared Menu, LocalTalk Menu, and USB Menu.
- Restore LES—all non-standard applications are removed, all frame-work and standard application settings are reset to their factory default values, and then the SE logs are cleared.

To restore Factory Defaults:

1. Print **Menu Settings** from the Administration Menu, the Diagnostic Menu, and the Config Menu.
If you need to reset customer settings you have a record.
2. Touch **Factory Defaults** from the Config Menu.
3. Touch **Restore Base**, **Restore STD NET**, or **Restore LES**. The Restore Network value only appears on printer models that have integrated network support.
Restoring Factory Defaults... appears on the operator panel while factory defaults are restored.
Resetting the Device... appears and the MFP performs a POR.

After a POR, the printer starts in the Home state.

Energy Conserve

This menu item affects the values that appear in the Power Saver menu on the operator panel. Energy Conserve only appears when the Power Saver feature is disabled.

Select **Off** in Energy Conserve to add a menu item to the Power Saver called *Disabled*. Energy Conserve does not disable Power Saver, it only allows the users to select **Disable**. When **On** (default) is selected in the Energy Conserve menu *Disabled* does **not** appear on as a choice in the Power Saver menu. Power Saver cannot be disabled from the user's operator menu.

To change the Energy Conserve setting:

1. Touch **Energy Conserve on** the Config Menu.
2. Touch the left arrow or the right arrow to toggle between On and Off.
3. Touch **Submit**.
Submitting changes... is displayed.

You are automatically returned to the Configuration main menu.

NumPad Job Assist

This setting determines whether or not a user can configure and initiate a job using the operator panel buttons. When this is set to **On**, a user can choose a function, such as copy, fax, or so forth, and then enter specific values for a limited number of settings and initiate the job with a series of key presses. When turned to **Off**, the feature is not available.

To change the NumPad Job Assist value:

1. Touch **NumPad Job Assist** on the Config Menu.
2. Touch the left arrow or the right arrow to toggle between On and Off.
3. Touch **Submit**.
Submitting changes... is displayed.

You are automatically returned to the Configuration main menu.

Min Copy Memory

This setting determines how much DRAM memory the MFP will allot to a priority queue. Amounts are 25, 35, 50, 80, or 100MB. The default is 80MB. The regular queue is interrupted for copy jobs in the priority queue.

To change the Min Copy Memory value:

1. Touch **Min Copy Memory** on the Config Menu.
2. Touch the left arrow or the right arrow to change between 25 MB, 35 MB, 50 MB, 80 MB, and 100 MB.
3. Touch **Submit**.
Submitting changes... is displayed.

You are automatically returned to the Configuration main menu.

Format Fax Storage

This procedure formats fax storage. When executed, this operation **ONLY** deletes faxes that are stored in the location identified by the value of the Fax Storage Location setting.

1. Touch **Format Fax Storage** in the Config Menu.
2. Touch either Yes or No

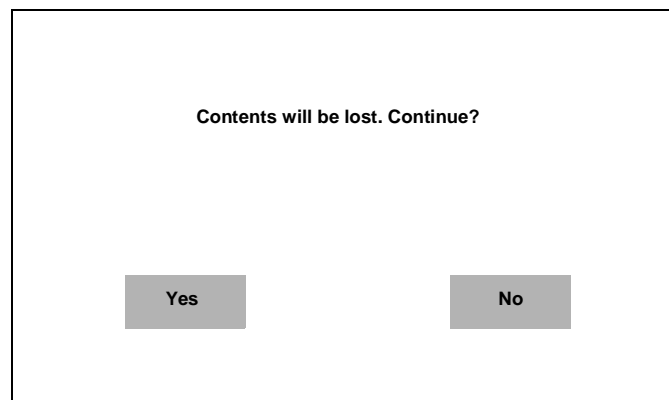

- If **Yes** is selected, Formatting Fax Flash DO NOT POWER OFF is displayed. Then you are automatically returned to the Configuration main menu.
- If **No** is selected, you are returned to the Configuration main menu.

Fax Storage Location

This setting only appears if a hard disk is installed. Selections are NAND or Disk.

1. Touch **Fax Storage Location** on the Config Menu.
2. Touch the left arrow or the right arrow to toggle between NAND and Disk.
3. Touch **Submit**.

Note: If a hard disk is not installed, the multiple function printer automatically stores all buffered faxes on NAND, and this menu does not appear. Disk is the default storage location.

ADF Edge Erase

The value of this setting determines the size (in millimeters) of the “no-print” zone around an ADF scan job. A copy job always has at least a 2mm border; therefore, the border size is either 2mm or the value of this setting, whichever is larger.

To change the value for ADF Edge Erase:

1. Touch **ADF Edge Erase** in the Config Menu.
2. Touch the right or left arrows to change the value from **0** to **6** (3 is the default).
3. Touch **Submit**.

Submitting changes... is displayed.

You are automatically returned to the Configuration main menu.

FB Edge Erase

The value of this setting determines the size (in millimeters) of the “no-print” zone around an ADF scan job. A copy job always has at least a 2mm border; therefore, the border size is either 2mm or the value of this setting, whichever is larger.

To change the value for FB Edge Erase:

1. Touch **FB Edge Erase** in the Config Menu.
2. Touch the right or left arrows to change the value from **0** to **6** (3 is the default).
3. Touch **Submit**.

Submitting changes... is displayed.

You are automatically returned to the Configuration main menu.

Scanner Manual Registration

This item is used to manually register the flatbed and ADF on the MFP scanner unit. Registration should be performed whenever the ADF unit, flatbed unit, or controller card are replaced.

To manually adjust the scanner:

1. Touch **Scanner Manual Registration**.

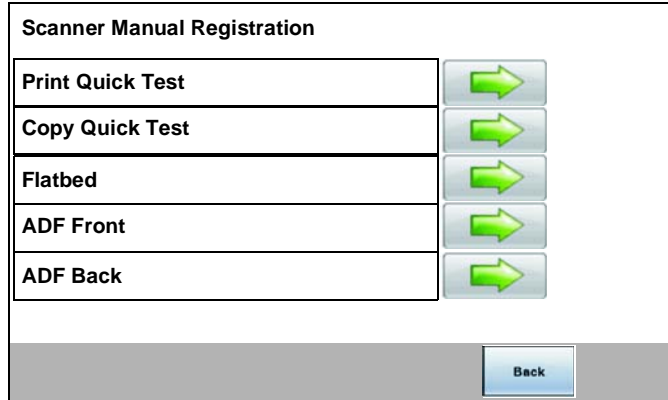

2. Touch **Print Quick Test**.
3. Place the quick test on the glass of the flatbed scanner.
4. Press **Copy Quick Test**.
5. Select **Flatbed**.



Examine the copy of the Quick Test and compare it to the original. Adjust the Left Margin and/or the Top Margin to match the original.

Selection	Effect
Left Margin	<ul style="list-style-type: none"> • Decrease the value and move the margin to the left. • Increase the value and move the margin to the right
Top Margin	<ul style="list-style-type: none"> • Decrease the value to move the margin down • Increase the value to move the margin upward.

6. Touch **Submit**.
Submitting changes... is displayed.
7. Place the original printout on the glass of the flatbed, and touch **Copy Quick Test**.
8. If the pages match, continue to step 9. If the pages do not match, repeat steps 4 through 7, until you are satisfied.
9. Place the original in the ADF, and touch Copy Quick Test.
10. Examine the copy of the Quick Test and compare it to the original. If it does not match, continue. If it does match, go to step 11. If it matches go to step 16.

11. Touch ADF Front.

ADF Front			
Horizontal Adjust		14	
Top Margin		3	

Adjust the Left Margin and/or the Top Margin to match the original.

Selection	Effect
Horizontal Adjust	<ul style="list-style-type: none"> Decrease the value to move the margin to the left Increase the value to move the margin to the right
Top Margin	<ul style="list-style-type: none"> Decrease the value to move the margin down Increase the value to move the margin upward.

12. Touch Submit.

Submitting changes... is displayed.

- 13.** If the pages match, continue to step 14. If the pages do not match, repeat steps 8 through 12, until you are satisfied.
- 14.** Place the original Quick Test in the ADF facedown, and touch **Copy Quick Test**.
- 15.** Examine the copy of the Quick Test, and compare it to the original. If the pages match, you are done. If the pages do not match, continue to the next step.
- 16.** Touch **ADF Back**. (This setting only appears on duplex machines)

ADF Back			
Horizontal Adjust		14	
Top Margin		3	

Adjust the Left Margin and/or the Top Margin to match the original.

Selection	Effect
Horizontal Adjust	<ul style="list-style-type: none"> Decrease the value to move the margin to the left Increase the value to move the margin to the right
Top Margin	<ul style="list-style-type: none"> Decrease the value to move the margin down Increase the value to move the margin upward.

17. Touch Submit.

Submitting changes... is displayed.

Touch **Back** at any time to return to the initial manual scanner registration screen without saving any changes.

Disable Scanner

If a scanner is not working, the scanner can be disabled, allowing the user to continue using the printer portion of the multiple function printer. **Disable** disables the entire scanner (ADF and flatbed), and then users attempting to use the scanner function receive *Scanner disabled by administrator message*. **ADF Disabled** disables only the ADF, but the flatbed continues to function. Users will receive a *Automatic document feeder disabled by administrator message*, and the paper present sensor in the ADF reports empty. **Enabled** turns the scanner back on, and is the default setting.

Auto Disabled is not a selection. It appears in response to certain scanner operation failures, and indicates the scanner is already disabled. **Submit** is disabled when it appears.

To disable the scanner:

1. Touch **Disable Scanner** in the Config Menu.
2. Touch the left or right arrows to select **Enabled** (default), **Disabled**, or **ADF Disabled**.
Auto Disabled appears in response to certain scanner operation failures.
3. Touch **Submit**.
Submitting changes... is displayed.

You are automatically returned to the Configuration main menu.

Automatic Color Adjust

Sets the suggested number of pages which the printer should print between consecutive calibrations.

If the printer exceeds the set value while printing a job, it completes the current job and any other jobs received while printing the current job before it initiates a calibration. The printer does not cancel or suspend an active job in order to perform a calibration. If a user is in any of the menus, including the Configuration Menu and the Diagnostics mode, an automatic color adjust calibration does not occur.

1. Touch **Auto Color Adjust** in the Config Menu.
2. Touch the left arrow to decrease the value or the right arrow to increase the value.
Selections are **Off** and the values between **100** and **1000** in increments of 50. The default is 500 pages.
3. Touch **Submit**.
Submitting changes... is displayed.

You are automatically returned to the Configuration main menu.

Auto Align Adj

Controls whether the printer executes the automatic alignment calibration after an initiating event occurs. When an event initiates a TPS operation, the printer performs a toner density calibration, (TPS) an alignment calibration, or both of the calibrations.

Toner Patch Sensing (TPS) is a diagnostic mechanism that automatically adjusts the printer toner density and alignment settings. When TPS executes, the printer generates toner patches on the transfer belt. It then uses these to calculate the appropriate adjustment, to density, if necessary.

To adjust the Auto Align Adj setting:

1. Touch **Auto Align Adj** in the Config Menu.
2. Touch the left arrow or the right arrow toggle between **Off** and **On** (default).
3. Touch **Submit**.
Submitting changes... is displayed.

You are automatically returned to the Configuration main menu.

Enforce Color Order

This setting gives the system support person the ability to enforce where the color cartridges may be placed, and if messages appear when cartridges are in the wrong location.

When **On** (default) is selected, the printer lets users place each toner cartridge in only its specified slot. For instance, the Magenta toner cartridge must be in the Magenta slot. If the user tries to place a cartridge in an incorrect slot, the printer message 31 Defective or Missing *<color>* Cartridge or 32 Unsupported *<color>* Cartridge appears where *<color>* stands for Cyan, Magenta, Yellow, or Black.

When **Off** is selected, the printer does not issue any message to let the user know that the cartridge is placed in the wrong slot inside the printer.

To adjust the Enforce Color Order setting:

1. Touch **Enforce Color Order** in the Config Menu.
2. Touch the left arrow or the right arrow toggle between **Off** and **On** (default).
3. Touch **Submit**.
Submitting changes... is displayed.

You are automatically returned to the Configuration main menu.

Color Alignment

Color alignment should be performed when the transfer module is replaced.

To perform color alignment:

1. Touch **Color Alignment** from the Config Menu.
2. Touch **Print Alignment**.
Four pages print with charts and letters A–L.
3. Consulting the printed page, look at Set A.
Indicate the number of the 20 color lines closest to the black lines.
4. Enter that number on the operator panel using the left and right arrows.
5. Continue selecting the best lines for the sets through **Set L and entering them on the operator panel**.
6. Touch **Submit** when all are entered.

Color Adj State

These settings allow you to select when color calibrations occur. Selecting **Busy** indicates the color calibrations will complete queued jobs, but refuse to add new jobs to the queue. When calibration is complete jobs are again accepted. Selecting **Idle** allows calibrations only when the printer is idle.

To adjust the Color Adj State setting:

1. Touch **Color Adj State** in the Config Menu.
2. Touch the left arrow or the right arrow toggle between **Busy** and **Idle**.
3. Touch **Submit**.
Submitting changes... is displayed.

You are automatically returned to the Configuration main menu.

Motor Calibration

This setting synchronizes the aligner and fuser motor speeds with the transfer belt speed to ensure that the output is printed correctly.

Note: This test should be run at 600 dpi resolution and with duplex disabled.

To run the Motor Calibration:

1. Touch **Motor Calibration** in the Config Menu.
2. Touch **Motor Calibration**.
Calibrating... displays, and then the multiple function printer feeds eight blank pages.

Touch **Back** to return to the Configuration main menu.

Paper Prompts

Controls the source the printer selects for a change paper source message. The printer displays the change paper source message based on the size of the paper requested and not by the paper type.

Selections include **Auto**, **Multi-Purpose Feeder**, and **Manual Paper**. The multipurpose feeder is available on some printer models.

Note: If the Configure MP setting is changed to Manual, a power-on reset is performed, and then the value of the Paper Prompts menu item before the power-on reset was MP Feeder, then when the printer restarts, the printer automatically changes the Paper Prompts setting to Manual Paper.

Load Manual overrides that would result in a change paper message are disabled for **Paper** or **Env** prompts that are set to Manual, Manual Paper, or Manual Env.

To change the settings for Paper Prompts:

1. Touch **Paper Prompts** in the Config Menu.
2. Touch the left or right arrow to toggle between **Auto**, **Multi-Purpose Feeder**, and **Manual Paper**.
3. Touch **Submit**.
Submitting changes... is displayed.

You are automatically returned to the Configuration main menu.

Envelope Prompts

Controls the source the printer selects for a change envelope source message. The printer displays the change envelope message based on the size of the envelope requested and not by the envelope type.

Selections include Auto, MP Feeder, and Manual Env. MP Feeder is only available on some printer models.

Note: If the Configure MP setting is changed to Manual, and a power-on reset is performed, and the value of the Env Prompts menu item before the power-on reset was MP Feeder, then when the printer restarts, the printer automatically changes the Env Prompt setting to Manual Env.

Load Manual overrides that would result in a change paper message are disabled for Paper or Env prompts that are set to Manual, Manual Paper, or Manual Env.

To change the settings for Env Prompts:

1. Touch **Envelope Prompts** in the Config Menu.
2. Touch the left or right arrow to toggle between **Auto**, **Multi-Purpose Feeder**, and **Manual Envelope**.
3. Touch **Submit**.
Submitting changes... is displayed.

You are automatically returned to the Configuration main menu.

Action for Prompts

This setting gives the user the option of having the printer resolve change prompt situations without requiring any user assistance. If the **Prompt user** value is selected, the printer displays change prompts if the job does not match the media in the selected source. The user must select another source or change the paper. If **Continue** or **Use current** is selected, the printer acts as if the user made the selection **Continue** or **Use current** and continues without user intervention, in most cases.

1. Touch **Action for Prompts** in the Config Menu.
2. Touch the left or right arrow to toggle between **Prompt user**, **Continue**, and **Use current**.
3. Touch **Submit**.
Submitting changes... is displayed.

You are automatically returned to the Configuration main menu.

Duplex Gloss

Generates higher quality duplex copies than when using the normal duplex mode. The major difference between normal duplex and duplex gloss mode is the number of sheets in the duplex print media path. Normal duplex mode feeds two sheets simultaneously, while duplex gloss feeds only one sheet.

Selections include **Off** (default) and **On**.

Jobs on Disk

Lets the user select whether or not the printer deletes all buffered jobs on the hard disk. This menu item only appears if a hard disk is installed. It appears even if no buffered jobs exist on the hard disk.

Selections include **Do Not Delete** and **Delete**.

Note: **Delete** does not remove Print and Hold jobs. Use **Remove Held Jobs** in the Utilities Menu (user menu) to delete these jobs.

To delete jobs on stored on the hard disk:

1. Touch **Jobs on Disk** in the Config Menu.



2. Touch Delete to erase stored jobs, or touch Do not delete to return to the menu without deleting any jobs.

Disk Encryption

Controls whether the printer encrypts the information that it writes to the hard disk.

Warning: When the value for Disk Encryption, the printer completely formats the hard disk which means that all information on the disk is deleted.

If an encrypted disk is removed from the printer and another disk is installed, the **Disk Corrupted. Reformat?** message appears. The newly installed disk must either be formatted or removed from the printer. The Disk Encryption menu item only appears when:

- A non-defective disk is installed in the printer.
- The values of bits 3-2 of digit 4 in the Configuration ID 2 are either 01 for Supported, or 10 for Supported with an internal network adapter (INA).

Selections include **Disable** (default) and **Enable**. When Disk Encryption is selected, Yes or No appears for you to confirm. Select either **Yes** or **No**. To cancel, touch **No**.

To encrypt a disk:

1. Touch Disk Encryption in the Config Menu.

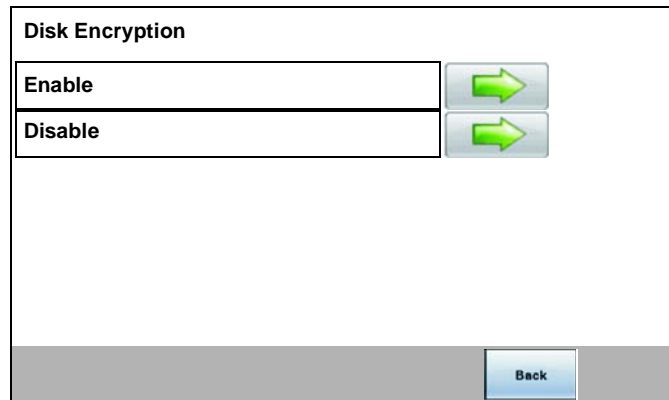

2. Touch **Enable** to encrypt the disk.



3. Touch **Yes**.

Warning: To prevent damage to your disk, do not turn the MFP off while the following displays.



4. Touch **Back** to return to the main menu.

A graphic appears, showing:

- The message **Encrypting Disk** or **Formatting Disk**
- A percentage scale
- The message **DO NOT POWER OFF**

The process is complete when the percentage scale displays 100.

Wipe Disk

Note: Due to the lengthy amount of time required to wipe an entire hard disk using either method, a wipe should not be initiated unless it is absolutely unavoidable (for example, disk corruption), or unless the printer can remain offline for several hours without inconveniencing users.

Warning: A user should not initiate either type of wipe from the Configuration Menu if the hard disk contains downloaded fonts, macros, held jobs, and so forth that should not be erased.

This setting initiates either a single pass wipe or a multiple pass wipe of the entire hard disk. Select **Disk Wipe (fast)** to complete a single pass wipe and replacement of the file system. Select **Disk Wipe (secure)** to complete a multiple pass wipe at a more basic level.

Duplex Gloss

If you need higher quality duplex copies, selecting Duplex Gloss give you a higher quality output. It does this by limiting the number of pages fed at one time. In normal duplex, two sheets are fed simultaneously and one is printed on page two and the other is printed as page four, then the pages are re-fed and pages one and three are printed on the other side. With Duplex Gloss turned on, only one page is fed, printed, re-fed and the reverse is printed. The quality increases, but the time it takes to complete the job is increased.

To turn on Duplex Gloss:

1. Touch **Duplex Gloss** in the Config Menu.
2. Touch the left or right arrow to toggle between **Off** and **On**.
3. Touch **Submit**.

Font Sharpening

Lets a user set a text point-size value below the setting of the high frequency screens used when printing font data. This menu item only affects the PostScript, PCL, XL, and PDF emulators.

Settings are in the range of 0–150 (24 is the default). For example, if the value is set to 24, then all fonts sized 24 points or less use the high frequency screens. To increase value by 1, touch the right arrow; to decrease the value by 1, touch the left arrow.

To set Font Sharpening:

1. Touch **Duplex Gloss** in the Config Menu.
2. Touch the left or right arrow to change the value from 1 to 150.
3. Touch **Submit**.

Require Standby

When set to Off, the Standby Mode setting in General Settings Menu displays Disabled. The default is On.

To set Require Standby:

1. Touch **Require Standby** in the Config Menu.
2. Touch the left or right arrow to toggle between **On** and **Off**.
3. Touch **Submit**.

LES Applications

Enables or disables Lexmark Embedded Solutions (LES) applications. The default is Enable.

To change the setting:

1. Touch **LES Applications** in the Config Menu.
2. Touch the left or right arrow to toggle between **Enable** and **Disable**.
3. Touch **Submit**.

Key Repeat Initial Delay

Determines the initial length of delay before a repeating key starts repeating. The range is from 0.25 seconds to 5 seconds in 0.25 second increments. The default value is 1 second.

To set the delay:

1. Touch **Key Repeat Initial Delay** in the Config Menu.
2. Touch the left or right arrow to change the value from 0.25 second to 5 seconds.
3. Touch **Submit**.

Key Repeat Rate

Number of presses per second for a repeating key. The range is from 1 to 100 presses per second. The default is 15 presses per second.

To set the number of key presses per second:

1. Touch **Key Repeat Rate** in the Config Menu.
2. Touch the left or right arrow to change the value from 1 to 100.
3. Touch **Submit**.

Clear Custom Status

Executing this operation erases any strings that have been defined by the user for the Default or Alternate custom messages.

To clear custom strings:

1. Touch **Clear Custom Status** in the Config Menu.
2. Touch **Clear Custom Status** again to confirm.
Clear Custom Status... appears.

Press **Back** to return to the Config Menu.

Pel Blurring

Customers who notice step artifacts in their error diffused copies to activate the pel synthesis function. The settings are On and Off (the default is Off).

1. Touch **Pel Blurring** in the Config Menu.
2. Touch the left or right arrow to toggle between **On** and **Off**.
3. Touch **Submit**.

USB Speed

A value of Full forces the USB port to run at full speed, and also disables its high-speed capabilities. Settings are Full and Auto. Auto is the default.

To set USB Speed:

1. Touch **USB Speed** in the Config Menu.
2. Touch the left or right arrow to toggle between **Full** and Auto.
3. Touch **Submit**.

Exit Config Menu

Touch Exit the Config Menu. The printer performs a power-on reset and returns to normal mode.

Service Engineer (SE) Menu

To enter the SE Menus:

From browser, add "/se" to device's IP address (for example: <http://123.456.7.8/se>).

Print SE Menus		
General		
	Copyright	Displays copyright information.
	Lexmark Forms Mode	On or Off
Code Revision Info		
	Network Code Level	Displays network code level.
	Network Compile Info	Display network compile information.
	Printer Code Level	Displays printer code level.
	Printer Compile Info	Displays compile information.
History		
	Print History	
	Mark History	
	History Mode	
MAC		
	Set Card Speed	
	LAA	
	Keep Alive	
NVRAM		
	Dump NVRAM	
	Reinit NVRAM	
NPAP		
	Print Alerts	
TCPIP		
	netstat -r	
	arp -a	
	Allow SNMP Set	
	MTU	
	Meditech Mode	
	Raw LPR Mode	
	Gather Debug	
	Enable Debug	
Netware		
	Broadcast SAPs	
	NPA Delay	

Front cover locked in place

The front door locks during certain Busy events, and unlocks when those events are complete. This is a normal function. You can hear the door lock into place when one of these events take place. However, if the printer is turned off, or has an error while the front door is locked (for example, while printing or calibrating), the front door may not unlock. If this happens, turn the printer off and restart it. Once it goes through POR, it may unlock itself. If this does not work, use the following procedure to unlock the front door:

1. Remove the rear cover. Remove the four screws (A) securing the rear cover.

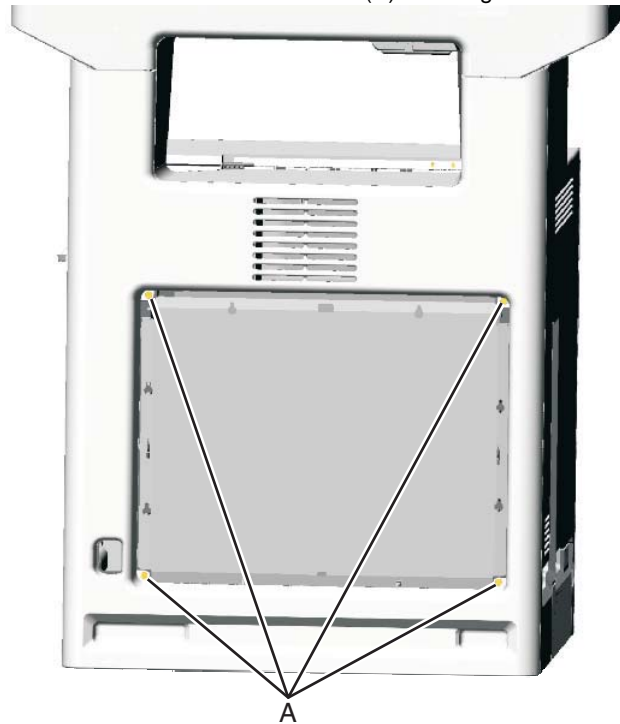

2. Lift up to disengage the two tabs (B).

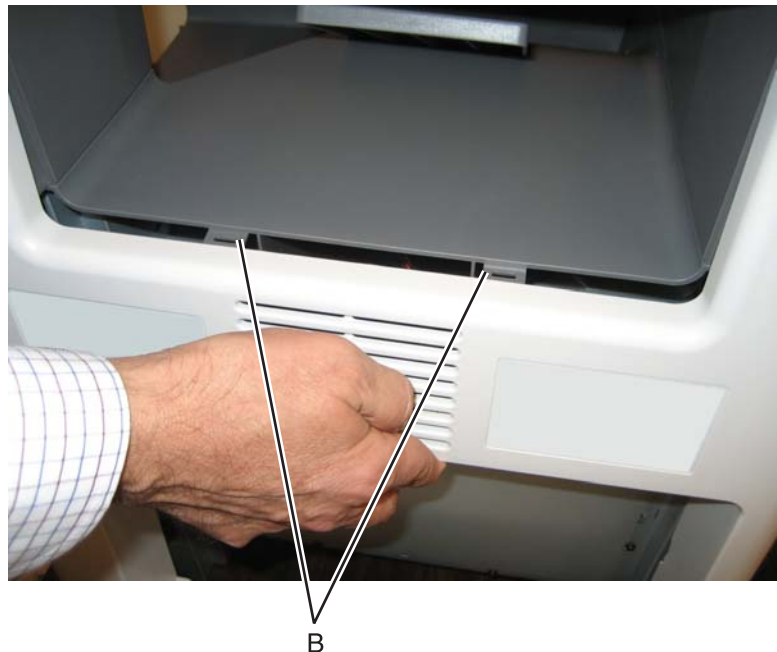

3. Open the top cover.
4. Remove the screw (C) from the inside left cover.

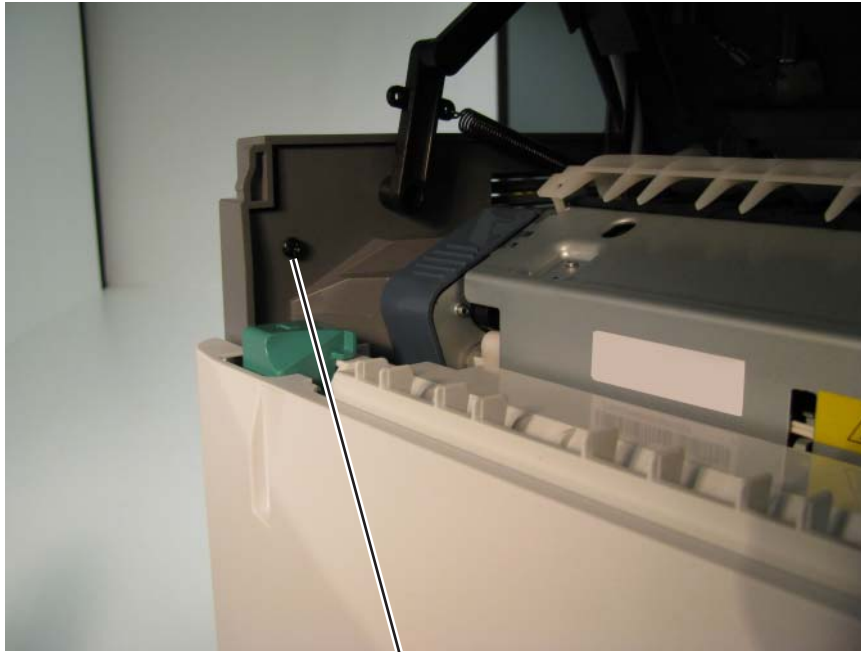

C

5. Press the waste toner release latch (D), swing the front of the waste toner assembly away from the printer, and remove.



D

6. Remove the two screws (E).
7. Press the locking tab (F), slide the cover down.

8. Grasp the side at the point shown, and disconnect the tab on the upper edge. Push down with your thumb on the outside while pulling up with the fingers to remove the cover.
Warning: Be careful not to damage the two small locking tabs (G).

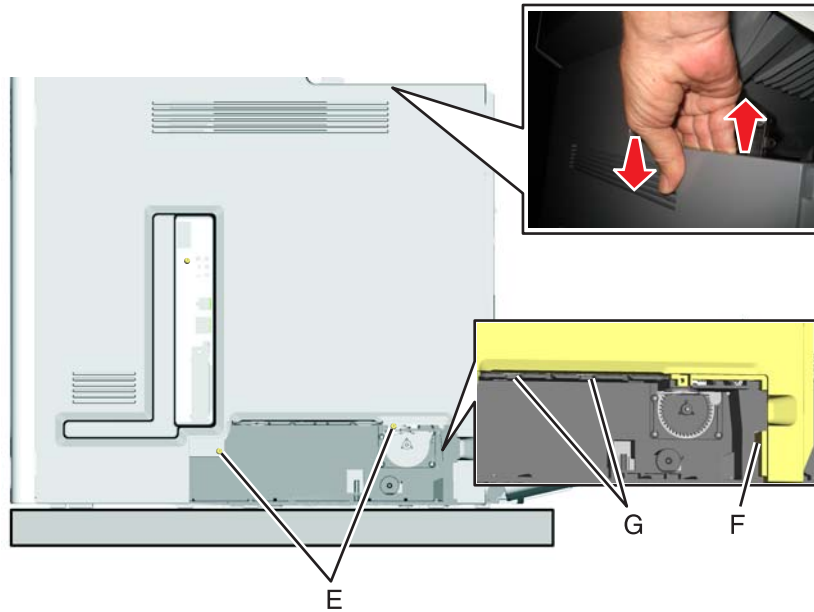

9. Lift the rear of the left cover out, and rotate it out of position toward the front.
Note: It will not come completely off with the front cover locked.
10. With a flatblade screwdriver, turn the camshaft counterclockwise until the door unlocks.



11. Open the front cover.

Printhead verification

Before you begin, you can verify that the printhead is the failing FRU by following this procedure:

1. Turn the printer off, remove the power cord from the outlet, then remove all cords and cables from the printer before beginning.
2. Locate the printer on a corner of a work area so the front and back can be accessed.



3. Remove the rear frame cover.
 - a. Loosen the eight screws (A).
 - b. Lift the rear frame cover, and remove.

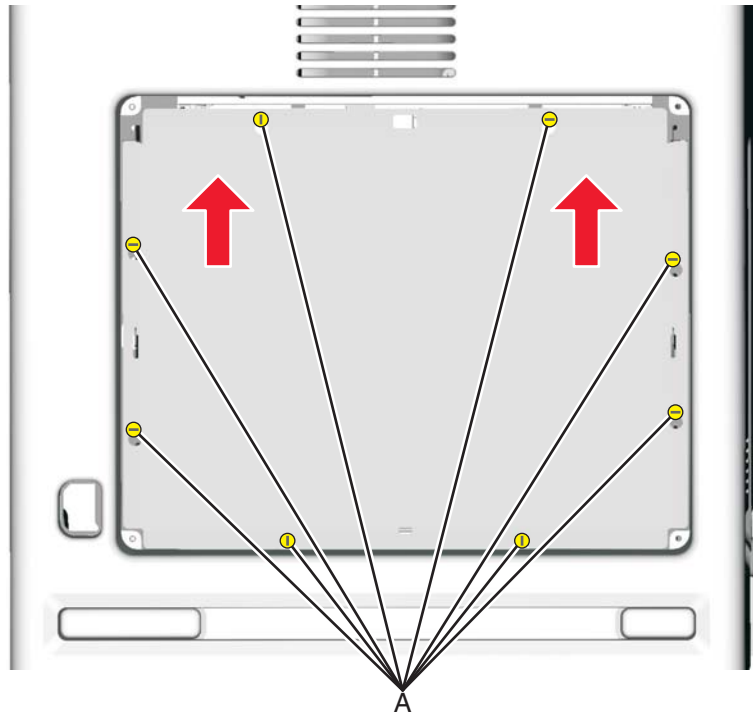

4. If present, remove the hard disk.
 - a. Remove the two screws (B), and disconnect the hard disk from the system board (C).

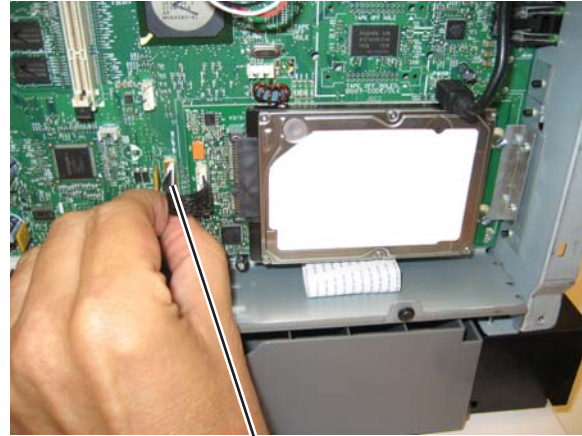
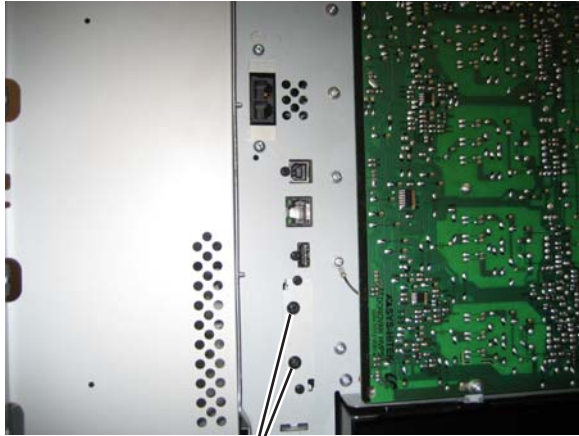

B

C

- b. Pull the hard disk straight out to *pop* the hard disk standoffs free of the system board.

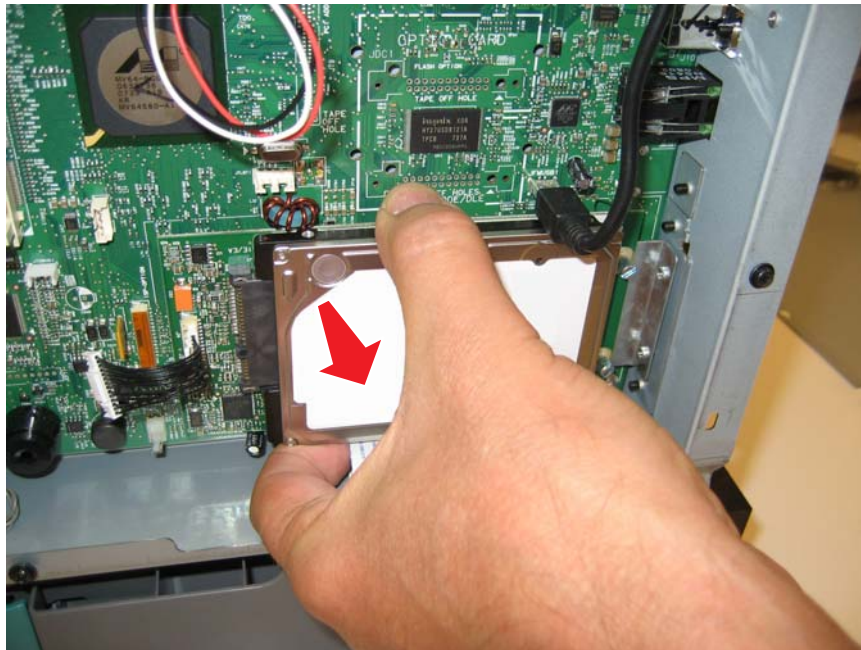

5. Carefully disconnect the printhead ribbon (D) and the mirror motor cables (E) from the system board, and carefully connect the printhead ribbon and mirror motor cables from the new printhead into the system board.



6. Use the packaging that came with the printhead FRU to prop the printhead up.

Note: It is important to position the laser in the printhead facing down into the packaging as shown.

	<p>CAUTION—POTENTIAL EYE INJURY:</p> <p>Laser Radiation—Avoid eye exposure to the beam. Always point the printhead laser down into the packaging as shown. The laser can cause damage to your eyesight or the eyesight of others.</p>
---	---



7. Connect the power cord to the outlet.
8. Enter the Diagnostics menu (press and **3** and **6**, turn on the multifunction printer, and release the buttons when the progress bar appears).
9. Perform the Mirror Motor Test:
- Touch **PRINTHEAD TESTS**.
 - Touch **Mirror Motor Test**.
The touchscreen displays Mirror Motor Test—Motor Running...
After the test completes, the touchscreen displays either Pass or Fail.
 - If the test fails, replace the system board.
 - If the test passes, perform the Servo Laser Test in step 9.
10. Perform the Servo Laser Test:
- Touch **Back to PRINTHEAD TESTS**.
 - Touch **Servo Laser Test**.
The touchscreen displays Servo Laser Test—Motor Running...
After the test completes, the touchscreen displays either Pass or Fail.
 - If the test fails, replace the system board.
 - If the test passes, install the printhead FRU.

Paper Jams

Error jam locations

The following illustration shows the location and error codes generated for specific paper jams and the corresponding locations of these jams.

ADF and flatbed scanner

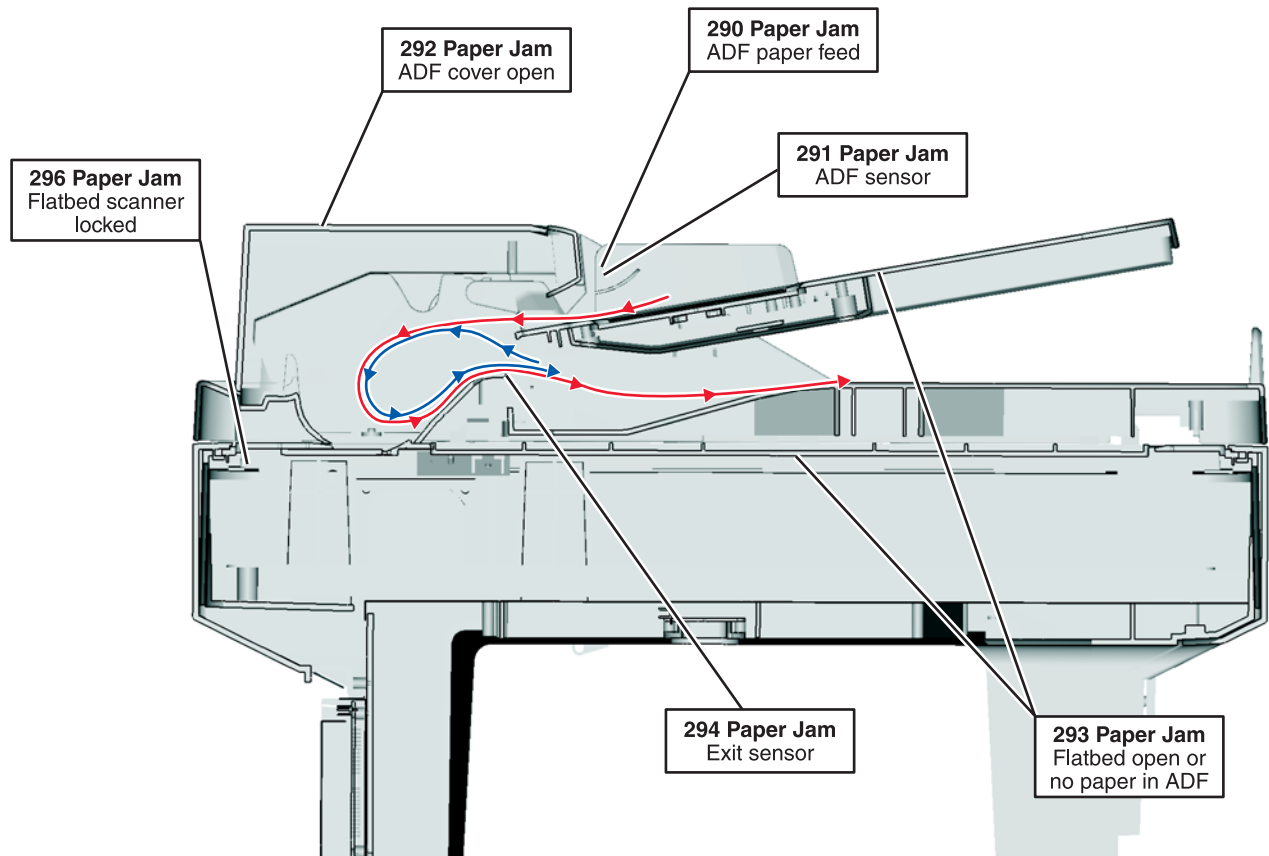

Printer base

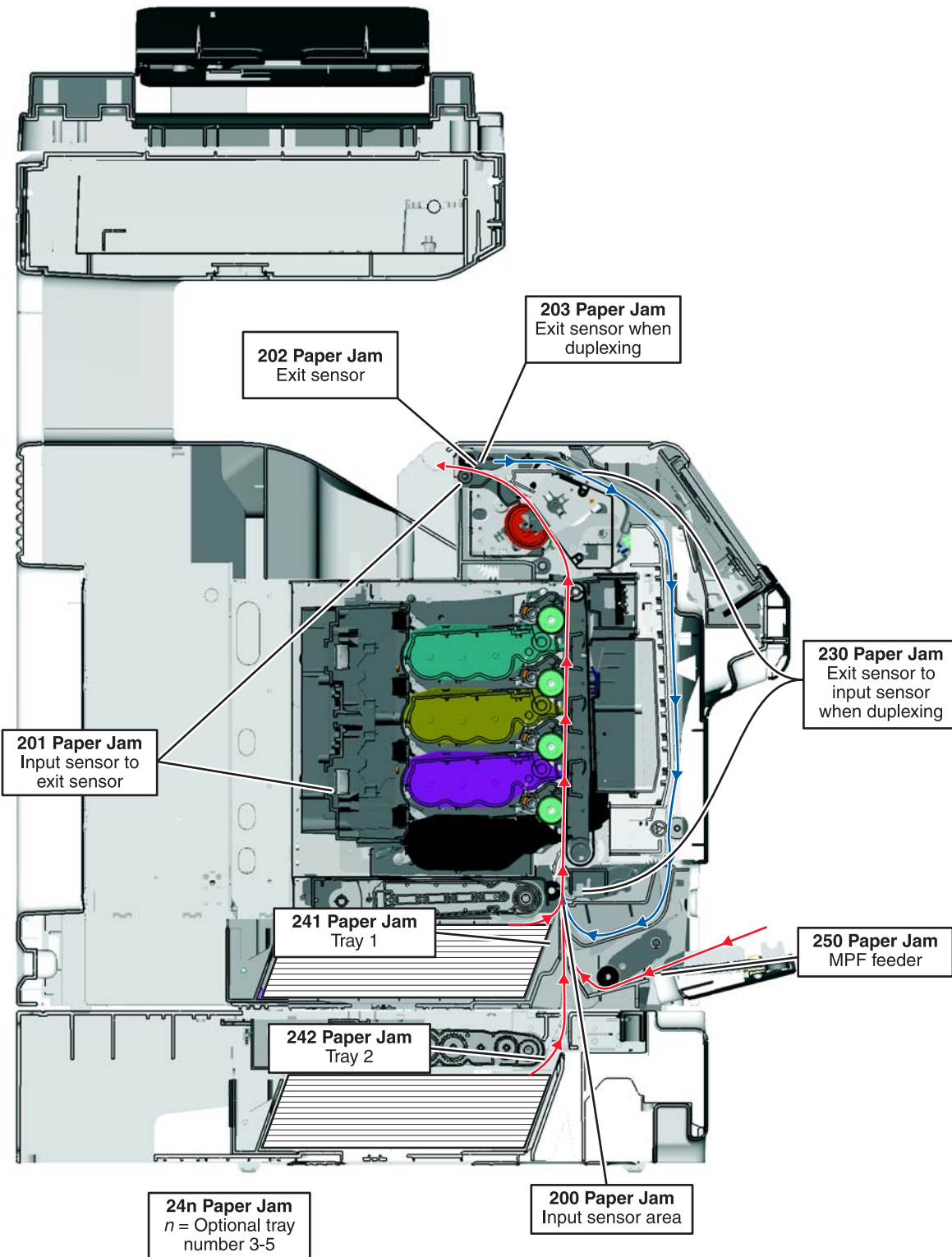

Clearing jams

By carefully selecting paper and loading it properly, you can avoid most jams. If jams do occur, follow the steps outlined in this section. To clear a jam message and resume printing, clear the entire paper path, and then touch **Continue**. If Jam Recovery is set to On, then the printer prints a new copy of the page that jammed. If Jam Recovery is set to Auto, then the printer reprints the jammed page if enough printer memory is available.

Avoiding jams

The following hints can help you avoid jams:

Paper tray recommendations

- Make sure the paper lies flat in the paper tray.
- Do not remove the paper tray while the printer is printing.
- Do not load the paper tray while the printer is printing. Load it prior to printing, or wait for a prompt to load it.
- Do not load too much paper. Make sure the stack height does not exceed the indicated maximum height.
- Make sure the guides in the paper tray or the manual feeder are properly positioned and are not pressing too tightly against the paper or envelopes.
- Push the paper tray in firmly after loading paper.

Paper recommendations

- Use only recommended paper or specialty media.
- Do not load wrinkled, creased, damp, bent, or curled paper.
- Flex, fan, and straighten paper before loading it.
- Do not use paper that has been cut or trimmed by hand.
- Do not mix paper sizes, weights, or types in the same stack.
- Make sure all sizes and types are set correctly in the printer control panel menus.
- Store paper per the manufacturer's recommendations.

Understanding jam messages

The following table lists the jam messages that can occur.

Message	See:
200 Paper jam, check [area name]	<ul style="list-style-type: none"> • “200 paper jam” on page 3-60 • “200–201 paper jams” on page 3-61
200 Paper jam, [x] pages jammed	
201 Paper jam, check [area name]	<ul style="list-style-type: none"> • “200–201 paper jams” on page 3-61 • “201 paper jam” on page 3-62
201 Paper jam, [x] pages jammed	
202 Paper jam, check [area name]	“202 paper jam” on page 3-63
202 Paper jam, [x] pages jammed	
203 Paper jam, check [area name]	“203 paper jam” on page 3-65
203 Paper jam, [x] pages jammed	
230 Paper jam, [area name]	“230 paper jam” on page 3-65
230 Paper jam, [x] pages jammed	
241 Paper jam, check [area name]	“24x paper jam” on page 3-67
241 Paper jam, [x] pages jammed	

Message	See:
24x Paper jam, check [area name]	"24x paper jam" on page 3-67
24x Paper jam, [x] pages jammed	
250 Paper jam, check [area name]	"250 paper jam" on page 3-68
250 Paper jam, [x] pages jammed	
290 Scanner jam, remove all originals from the scanner	"290–294 paper jams" on page 3-69
290 Scanner jam, remove jammed originals from the scanner	
291 Scanner jam, remove all originals from the scanner	
291 Scanner jam, remove jammed originals from the scanner	
292 Scanner jam, remove all originals from the scanner	
292 Scanner jam, remove jammed originals from the scanner	
293 Replace all originals if restarting job	
293 Replace jammed originals if restarting job	
293.02 Flatbed cover open	
293.02 Replace jammed originals if restarting job	
294 Scanner jam, remove all originals from the scanner	
294 Scanner jam, remove jammed originals from the scanner	
294.01 Scanner jam, remove all originals from the scanner	
294.01 Scanner jam, remove jammed originals from the scanner	

200 paper jam

1. Open the upper front door.



CAUTION—HOT SURFACE:

The inside of the printer might be hot. To reduce the risk of injury from a hot component, allow the surface to cool before touching.

2. Open the lower front door.

Note: To avoid overexposing the photoconductor units, do not leave the lower front door open longer than 10 minutes.

3. Pull the jammed paper up and out to remove it from behind the toner cartridge area.
Note: Make sure all paper fragments are removed.

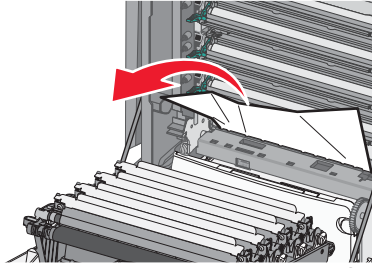

4. Close the lower front door.
5. Close the upper front door.
6. Touch **Continue**.

200–201 paper jams

1. Open the upper front door.



CAUTION—HOT SURFACE:

The inside of the printer might be hot. To reduce the risk of injury from a hot component, allow the surface to cool before touching.

2. Open the lower front door.
Note: To avoid overexposing the photoconductor units, do not leave the front door open longer than 10 minutes.
3. Pull the paper forward if it is lodged under the photoconductor units.
Note: You may need to remove the photoconductor units if the paper is lodged too tightly under them.

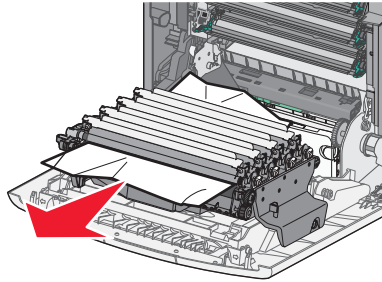

4. Remove each photoconductor unit, and then place it on a flat surface. See **“Photoconductor unit removal” on page 4-124**.
5. Remove the jammed paper, and then replace each photoconductor unit.
6. Close the lower front door.
7. Close the upper front door.
8. Touch **Continue**.

201 paper jam

1. Open the upper front door, and then open the lower front door.

Warning: Potential Damage—To avoid overexposing the photoconductors, do not leave the front doors open for more than 10 minutes.



CAUTION—HOT SURFACE:

The inside of the printer might be hot. To reduce the risk of injury from a hot component, allow the surface to cool before touching.

2. Determine where the jam is located, and then remove it:
 - If paper is visible under the fuser, then grasp it on each side and pull it forward.

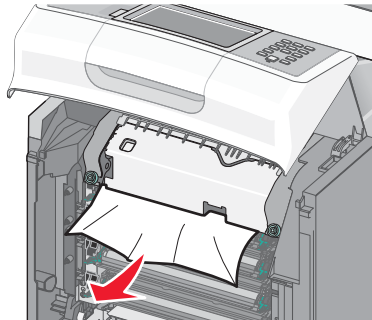

- If paper is not visible:
 - c. Turn the screws on the fuser to the left.

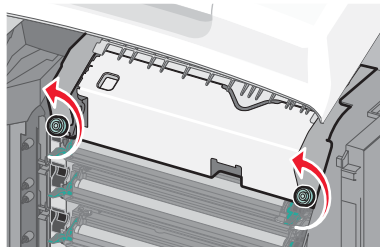

- d. Remove the fuser, and then remove the jam.

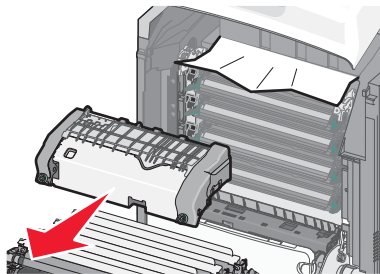

- e. Replace the fuser, and then turn the screws to the right to fasten it securely.
3. Close the lower front door, and then close the upper front door.
 4. Touch **Continue**.

202 paper jam

If the paper is visible in the standard exit bin, then grasp the paper and pull it away from the bin.

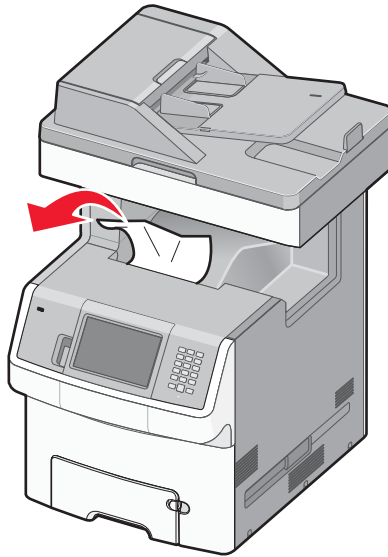

Paper jam under the fuser

1. Open the upper front door, and then open the lower front door.

Warning: Potential Damage—To avoid overexposing the photoconductors, do not leave the front doors open for more than 10 minutes.



CAUTION—HOT SURFACE:

The inside of the printer might be hot. To reduce the risk of injury from a hot component, allow the surface to cool before touching.

2. Grasp the paper on each side and pull it forward.

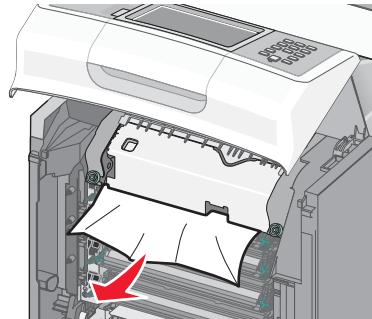

3. Close the lower front door, and then close the upper front door.
4. Touch **Continue**.

Paper jam behind the fuser

1. Open the upper front door, and then open the lower front door.

Warning: Potential Damage—To avoid overexposing the photoconductors, do not leave the front doors open for more than 10 minutes.



CAUTION—HOT SURFACE:

The inside of the printer might be hot. To reduce the risk of injury from a hot component, allow the surface to cool before touching.

2. If the paper is jammed behind the fuser, then remove the fuser:
 - a. Turn the screws on the fuser to the left.

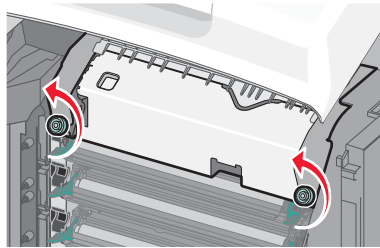

- b. Lift the fuser, and then pull forward to remove it.

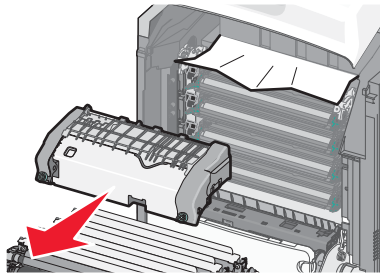

- c. Place the fuser on a flat surface.
3. Pull the paper gently out of the printer or up toward the standard exit bin to remove it.
4. Reinstall the fuser:
 - a. Align the fuser, and then place it back into the printer.
 - b. Turn the screws to the right to fasten the fuser securely.
5. Close the lower front door, and then close the upper front door.
6. Touch **Continue**.

203 paper jam

1. Grasp paper that is visible in the standard exit bin, and pull it away from the bin.

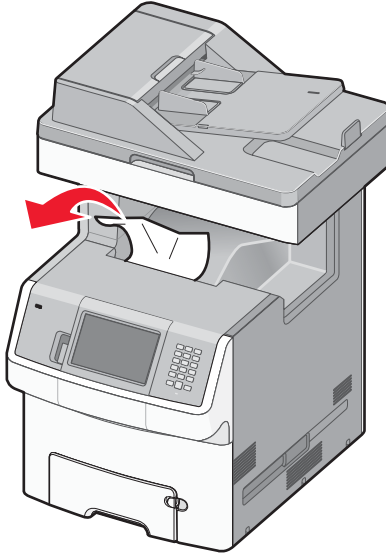

2. Open the upper front door.



CAUTION—HOT SURFACE:

The inside of the printer might be hot. To reduce the risk of injury from a hot component, allow the surface to cool before touching.

3. Open the lower front door.
4. Grasp the paper on each side, and pull it out gently.

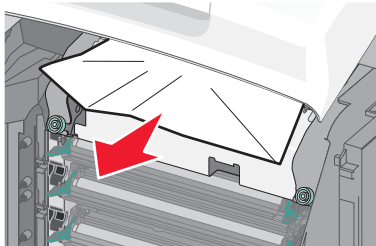

5. Close the lower front door.
6. Close the upper front door.
7. Touch **Continue**.

230 paper jam

1. Remove Tray 1.
2. Open the upper front door, and then open the lower front door.



CAUTION—HOT SURFACE:

The inside of the printer might be hot. To reduce the risk of injury from a hot component, allow the surface to cool before touching.

3. Pull the jam straight up to remove it.

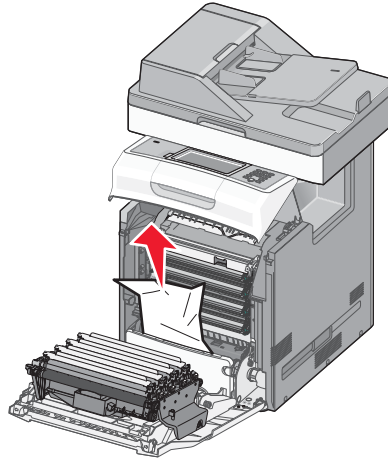

4. Pull out on the release tabs to allow the front door to split.

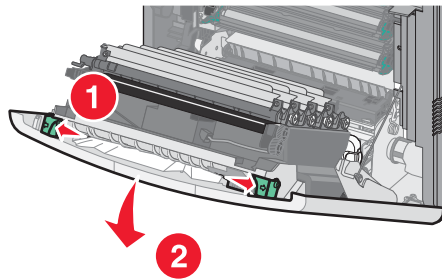

5. Pull straight out to remove any jammed paper.
6. Close the lower front door, and then close the upper front door.
7. Reinsert Tray 1.
8. Touch **Continue**.

24x paper jam

Paper jammed in Tray 1

1. Open Tray 1, and then pull the jammed pages straight up and out.

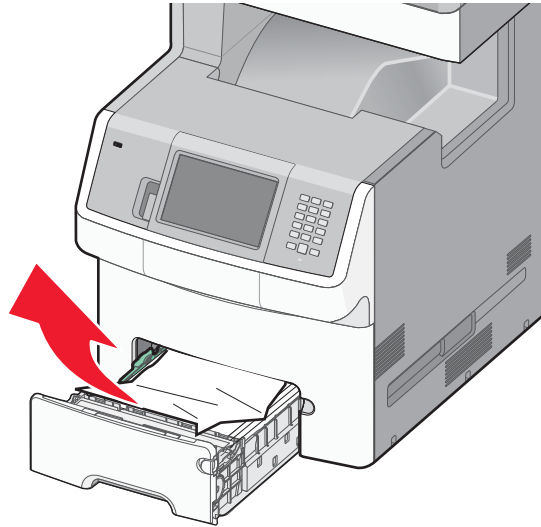

2. After removing the tray, the front door may need to be opened to access the jam.
3. Close Tray 1.
4. Touch **Continue**.

Paper jammed in front of Tray 1

1. Open Tray 1, and then pull the jammed pages up and out.

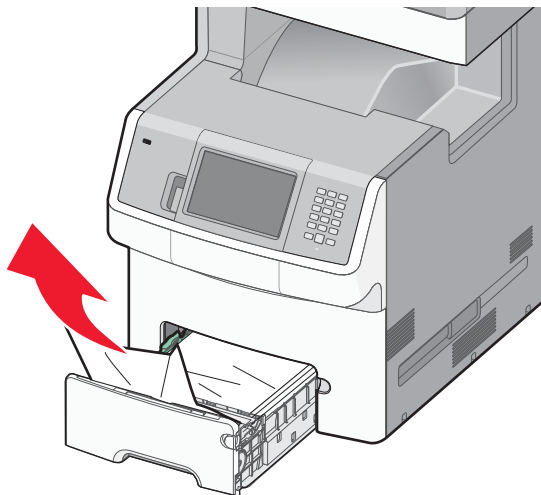

2. Close Tray 1.
3. Touch **Continue**.

Paper jammed in one of the optional trays

1. Open the specified tray, and then pull the jammed pages out.

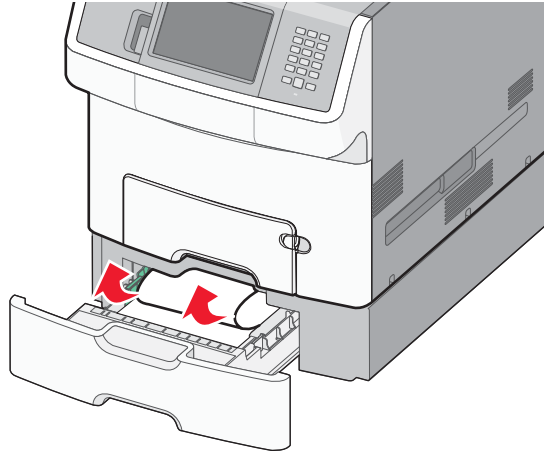

2. After removing the tray, the tray above may need to be opened to access the jam.
3. Close the tray.
4. Touch **Continue**.

250 paper jam

1. Press the paper release lever, and then remove the jammed pages from the multipurpose feeder.

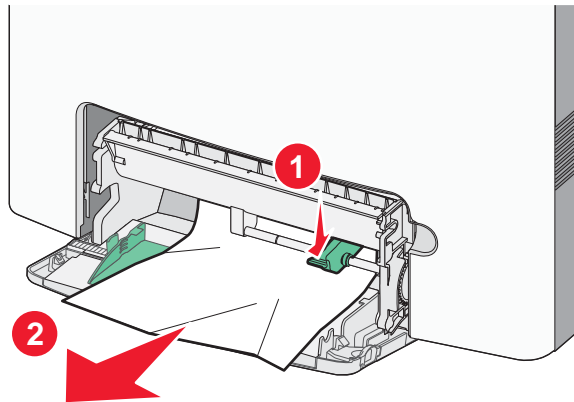

2. Load new paper into the multipurpose feeder.
3. Touch **Continue**.

290–294 paper jams

1. Remove all original documents from the ADF.
2. Open the ADF cover, and then remove any jammed paper.

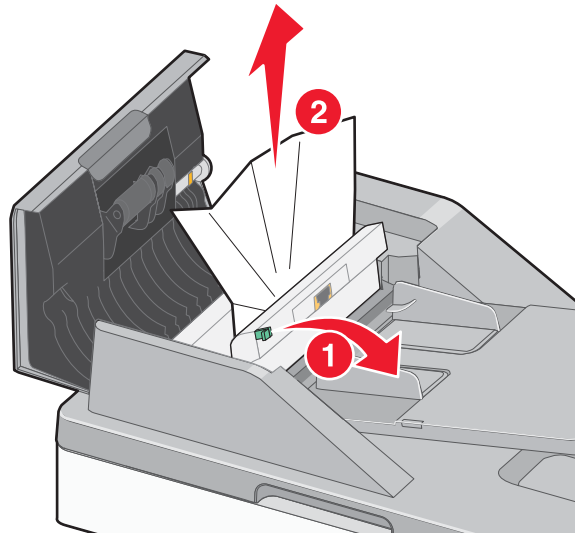

3. Close the ADF cover.
4. Open the duplex cover, and then remove any jammed paper.
5. Open the scanner cover, and then remove any jammed pages.
6. Close the scanner cover.
7. Touch **Restart Job**.

4. Repair information

	<p>CAUTION—POTENTIAL INJURY:</p> <p>The printer weight is greater than 97 lbs (44kg), and requires three or more trained personnel to lift safely.</p>
---	---

	<p>CAUTION—POTENTIAL INJURY</p> <p>When you see this symbol, there is a danger from hazardous voltage in the area of the product where you are working. Unplug the product before you begin, or use caution if the product must receive power in order to perform the task.</p>
---	--

Safety information

- The safety of this product is based on testing and approvals of the original design and specific components. The manufacturer is not responsible for safety in the event of use of unauthorized replacement parts.
- The maintenance information for this product has been prepared for use by a professional service person and is not intended to be used by others.
-  **CAUTION:** When you see this symbol, there is a danger from hazardous voltage in the area of the product where you are working. Unplug the product before you begin, or use caution if the product must receive power in order to perform the task.

Removal and cleaning precautions



Observe the following precautions whenever you service the printer:

- Be sure to unplug the printer from the outlet before attempting to service the printer.
- To reassemble the printer, reverse the order of removal unless otherwise specified.
- Do not operate the printer anytime during removals. If it is absolutely necessary to run the printer with its covers removed, use care not to allow your clothing to be caught in revolving parts such as the gears, rollers and fan motor.
- Never touch the terminals of electrical parts or high-voltage parts such as the high-voltage power supply.
- After part replacement, ensure the wiring harness is not caught or damaged.
- Do not attempt to cut or extend the wiring harness.
- Confirm the wiring harness connector is connected properly.
- Be sure to handle the fuser carefully as it remains hot for a while after the printer stops running. Always unplug connectors by holding the connector housing.

Warning: Read the following before handling electronic parts.

Handling ESD-sensitive parts

Many electronic products use parts that are known to be sensitive to electrostatic discharge (ESD). To prevent damage to ESD-sensitive parts, follow the instructions below in addition to all the usual precautions, such as turning off power before removing electronic cards:

- Keep the ESD-sensitive part in its original shipping container (a special “ESD bag”) until you are ready to install the part in the printer.
- Make the fewest possible movements with your body to prevent an increase of static electricity from clothing fibers, carpets, and furniture.
- Put the ESD wrist strap on your wrist. Connect the wrist band to the system ground point. This discharges any static electricity in your body to the printer.
- Hold the ESD-sensitive part by its edge connector shroud (cover); do not touch its pins.
- If you need to put down the ESD-sensitive part for any reason, first put it into its special bag.
- Printer covers and metal tables are electrical grounds. They increase the risk of damage because they make a discharge path from your body through the ESD-sensitive part. (Large metal objects can be discharge paths without being grounded.)
- Prevent ESD-sensitive parts from being accidentally touched by other personnel. Install printer covers when you are not working on the printer, and do not put unprotected ESD-sensitive parts on a table.
- If possible, keep all ESD-sensitive parts in a grounded metal cabinet (case).
- Be extra careful in working with ESD-sensitive parts when cold-weather heating is used, because low humidity increases static electricity.

Handling the photoconductor unit

The following precautions must be observed when handling the photoconductor unit. The photoconductor unit is a supply item you will have to remove during some of the repair procedures:

Transportation/storage

Use the specified carton whenever moving or storing the photoconductor unit.

Handling

- The optical photoconductor roller in the photoconductor unit exhibits the greatest light fatigue after being exposed to strong light over an extended period of time. Never expose it to direct sunlight. Cover the photoconductor unit when you remove it from the printer.
- Use care not to contaminate the surface of the optical photoconductor roller with an oil-based solvent, fingerprints, and other foreign matter.
- Do not scratch the surface of the optical photoconductor roller.

Parts not to be touched





Any part where the mounting screws are used to meet a printer alignment set at the factory must not be removed, disassembled, or adjusted.

Screw and retainer identification table



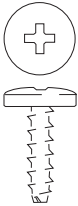

The following table contains screw types and retainers, locations, and quantities necessary to service the printer. Pay careful attention to each screw type location when doing removals. You must install the correct screw type in each location during reassembly.

Sizes are as close to actual as possible, as long as the printout is not scaled or resized.







Screw identification table

P/N	Screw type	Location	Qty
	Plastite M3x6, black	CCD cover	2
		CCD Lamp	2
		CCD Lamp cover	2
		Rear cover	6
	Plastite washer M3x8	CCD belt to flatbed	1
	Plastite M4x8	Upper housing	6
	Plastite M4x14	Hinges to ADF	4
	#6 Panhead	Cooling fan to top cover	2







Screw identification table (continued)

P/N	Screw type	Location	Qty
18B0832  	Taptite M3 L6 PANHD	5 V interlock switch to rightside frame	1
		Card support plate to upper plate	2
		Card support plate to lower plate	3
		Card support plate (and printhead ground) to leftside frame	5
		Card support plate to rightside frame	4
		Cartridge left guide assembly to leftside [late (interior side of plate assembly)	4
		COD drive assembly to upper plate	3
		COD shaft assembly to upper plate	2
		Contacts assembly to leftside frame next to auger worm gear	2
		Contacts assembly to leftside frame near duct	2
		Duct to frame	4
		EP drive to rightside plate (exterior side)	8
		Flatbed fan to housing	4
		Front door ground wire to rightside frame bracket	1
		Ground screws between scanner and printer frame	3
		HVPS to leftside frame plate	1
		Laser support plate to lower plate	2
		Left cam shaft lock assembly to printer frame	2
		Left frame assembly to lower plate	4
		Left frame assembly to laser support plate	2
		LVPS support plate to rightside plate	4
		LVPS to rightside frame plate and support bracket	5
		Motor driver card to EP drive assembly	2
		MP feeder drive cover to rightside frame	3
		Rear frame assembly	8
		Rear frame assembly to scanner support frame	2
		Right cam shaft lock assembly to printer frame	2
		Right frame assembly to laser support plate	2
		Right frame to lower plate	3
		Scanner support frame assembly to left frame	2
System board to RIP plate.	9		
Top cover assembly to printer frame	5		
Upper plate to rightside frame assembly	3		
Upper plate to leftside frame assembly	3		
Upper plate to laser support plate	3		
18B0939  	Plastite M3x6 FLATHD	Gearbox plate assembly to frame	4

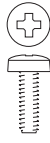





Screw identification table (continued)

P/N	Screw type	Location	Qty
18B1236 	Plastite panhead M3x6	ADF open sensor to ADF	2
		CCD belt to flatbed	2
		Sliding rod	2
18B2302 	Machine M2.6 L3-3.5	MP feeder/duplex drive motor to rightside plate	2
18B2315 	Machine M3 PANHD L35	Printhead	1
27S2836 	Taptite M3 L6 PANHD, black	Rear cover frame to frame	8
		Right cover to printer frame	4
		Rear cover to printer frame	4
27S2837 	M3.5X1.34 PANHD 8L, black	Left cover to lower swingout frame	2
		Top cover to left cover	1
		Top cover to right cover	1
27S2838 	Machine M3X0.5- 6G 6L, Black	Contacts assembly to left/front edge of printer frame	2
		ISP blank plate to left plate	2
		Second USB connector to left frame	1
		System board USB connector to frame	1
27S2839 	Taptite M3 L6 Taptite Slotted hex, black	Rear cover frame to frame	8

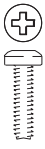





Screw identification table (continued)

P/N	Screw type	Location	Qty
88A0003 	Machine M3X0.5-6G 8L	Printhead	3
88A0095 	M2.5x10 Machine	5 V interlock switch actuator assembly	1
		24 V interlock switch and shield to rightside frame	1
88A0133 	Plastite M3x8	ADF front cover	2
		ADF handle cover	2
		ADF motor cover	3
		ADF upper front cover	1
		Cave LED lens	1
		Interconnect card to ADF	2
		Left cover	3
		Main case cover	2
		MDC card metal cage	4
		MDC card to frame	1
		Motor assembly to ADF	2
Right cover	1		
88A0212 	Taptite M3.5x0.6 PAN	AC inlet ground wire	1
		Fuser AC cable's ground wire to leftside plate	1
88A0232 	Taptite M3 L6 PANHD	AC inlet cable to frame extension	2
		Cartridge right guide assembly to rightside plate	10
		Lower frame support to rightside frame assembly	4
		Lower plate to lower swingout frame assembly	1
		Lower swingout frame assembly to leftside frame assembly	4
88A0233 	Taptite M3x8 PANHD	Lower swingout frame assembly to leftside frame assembly (rear most position)	1
		Upper housing	4

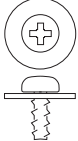
Screw identification table (continued)

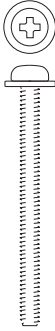
P/N	Screw type	Location	Qty
88A0234 	Taptite M3x10	Motor assembly to ADF	2
88A0293 	Plastite M2.2 L5	Contact spring cap to left guide assembly	4
88A0312 	Plastite M2.9 L6 PAN	Backup springs to reference edge plate assembly	2
		Cartridge cooling fan duct to top cover	2
		Cartridge left guide assembly to leftside plate assembly (exterior side of plate assembly)	3
		Cover mount to rightside plate	2
		Door bracket to front access door cover	2
		Door straps to front access door cover	2
		Duplex entry guide to front access door cover	4
		Front cover bracket to front access door cover	4
		Lower frame support to lower left frame assembly	2
		Option locator to rightside plate	1
88A0313 	Plastite M2.9 L8 PAN	Contacts assembly to leftside cartridge guide	1
		Cover CBM to upper front cover	3
		Cover pivot to swingout frame	3
		Duplex upper guide to top access door cover	2
		HVPS to transfer contact assembly	3
		HVPS to leftside cartridge guide assembly	2
		LCD assembly to operator panel housing	4
		Top access door cover to upper front cover assembly	6
		UICC card to top access door cover	4
88A0316 	Plastite M2.9x12 PAN	USB cable to top access door cover	2
88A0323 	M3.5X 1.34 Panhead 8L	Duplex upper guide to top access door cover	5
		Ground strap/contact to front door frame	1
		Lower right frame to right plate	3
		Pick assembly to lower plate	4
		Reference edge assembly to door assembly	2
		Torque tube cover to front door frame	6
		USB ground bracket to top cover	1

Screw identification table (continued)

P/N	Screw type	Location	Qty
88A0324 	M3.5X1.34 PANHD 10L	Door cap to door assembly	1
		EP drive to rightside plate	2
88A0412 	M2.9x5.2 Plastite	Door links to top access door cover	2
		Fuser retract link to top access door	1
		GS COD bellcranks to guide	3
		NGS COD bellcranks to guide	3
		Top cover links to top access door links	2
		Top cover links to top cover	2
88A0421 	Plastite M3x5	Bushing ground cable	1
		Ground bushing to ADF	1
		Ground wire in input tray	1
		Input tray bottom cover	7
		Paper present LED	1
MS00473 	Taptite M3 PANHD L32	Cartridge cooling fan to frame	2
MS00495 	Taptite M3 L12 PANHD	Scanner attachment to printer frame	5
1126828 	E-clip M3	LR overcenter bellcrank to side frame	1
1126829 	E-ring M4	MP feeder gears to right side frame studs	2

Adjustments

Printhead alignment

Overview

When aligning the printhead, it is important to keep in mind that the printhead mounting screws should be initially loose enough to just hold the printhead in the printer. This allows the pages to be printed that will be used to align the black plane to the printer frame and also allows skew adjustment with the printhead alignment screw. Once the black skew is adjusted, the mounting screws are fully tightened.

There is one printhead that houses the four color planes. The black plane is aligned to the printer, and the color planes are internally aligned to black. Electrical alignment is done to fine tune the alignment of the color planes to the black plane once the printhead is installed and skew is adjusted.

The first step in aligning the printhead is to loosen the printhead mounting screws, and to set the skew for black.

Note: If you need to replace the printhead, see **“Printhead removal, installation, and adjustment” on page 4-128.**

Printhead mechanical alignment

Skew (black)

1. Disconnect the electrical cord to the printer.
2. Disconnect the electrical cord to the outlet.
3. Remove the transfer module and photoconductor units:
 - a. Open the top access cover.
 - b. Open the front access cover.
 - c. Disconnect the transfer module cable (A).
 - d. Press the two tabs (B) to release the front access cover assembly.
 - e. Press the two tabs (C) on either side of the transfer module, and lift out the transfer module.

Note: Leave the photoconductor units on the transport module when removing.

To avoid damaging the photoconductor drum, place the transfer module with the photoconductor units on a clean surface. Never expose the photoconductor units to light for a prolonged period of time. You can place a clean, dry cloth over the transfer module and photoconductor units until they are required.

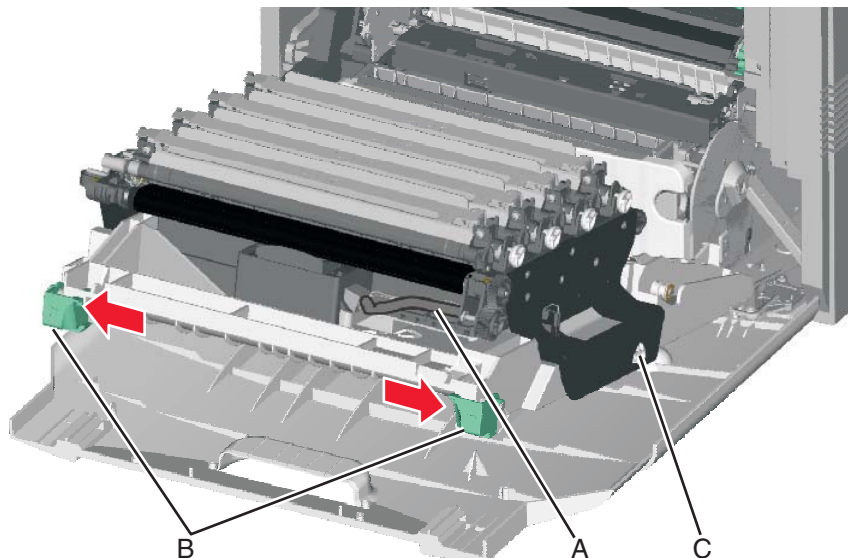

4. Remove the toner cartridges.
5. Loosen the printhead mounting screws (D).

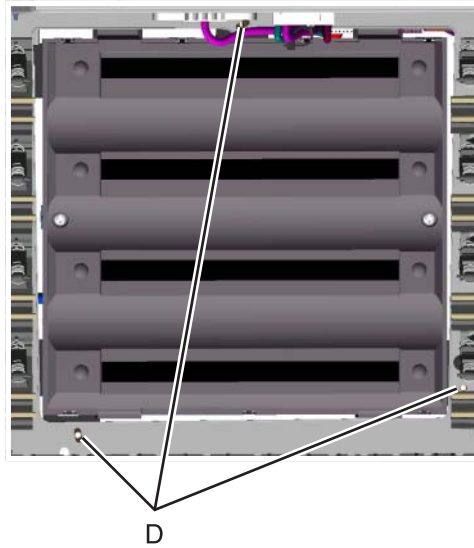

6. Reinstall the transfer module with the photoconductor units still attached.
7. Reconnect the transfer module cable.
8. Replace the toner cartridges.
9. Close the front access door.
10. Close the top access door.
11. Connect the electrical cord into the printer.
12. Connect the electrical cord into the outlet.
13. Align the printhead skew for black.
 - a. Enter Diagnostic mode (turn off the printer, press and hold 3 and 6, turn on the printer, and release the buttons when the progress bar appears).
 - b. Select **Registration**.

Registration			
Top Margin	◀	9	▶
Bottom Margin	◀	-1	▶
Left Margin	◀	-1	▶
Right Margin	◀	0	▶
Skew	◀	0	▶
Quick Test		▶	
Submit		Back	

- c. Adjust the value beside Skew to zero with the left and right arrows, and touch **Submit**.

d. Touch **Quick Test**. A page similar to this one prints:

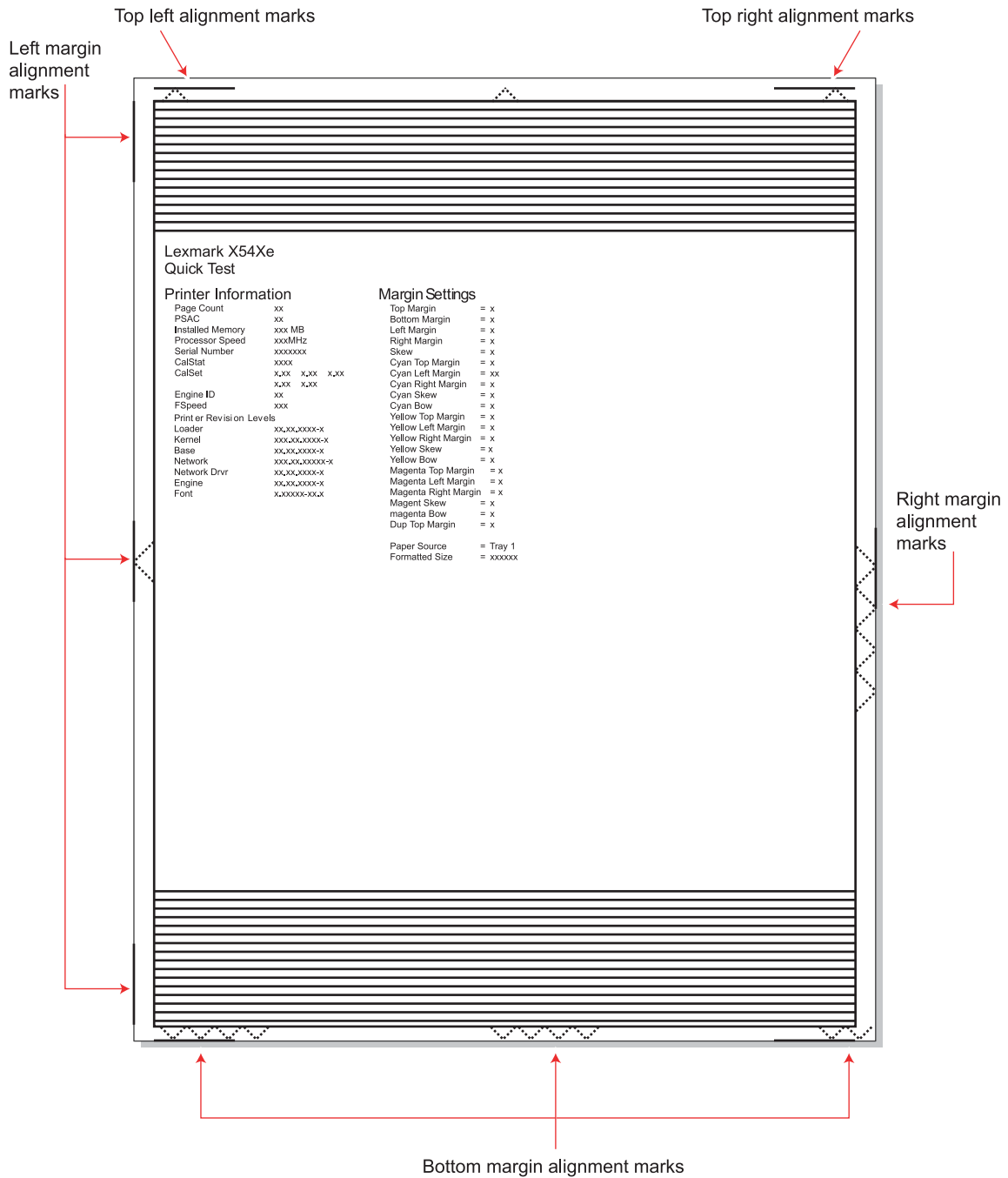

- e. Adjust the printhead alignment screw (F) to adjust the skew and straighten the image on the printout.

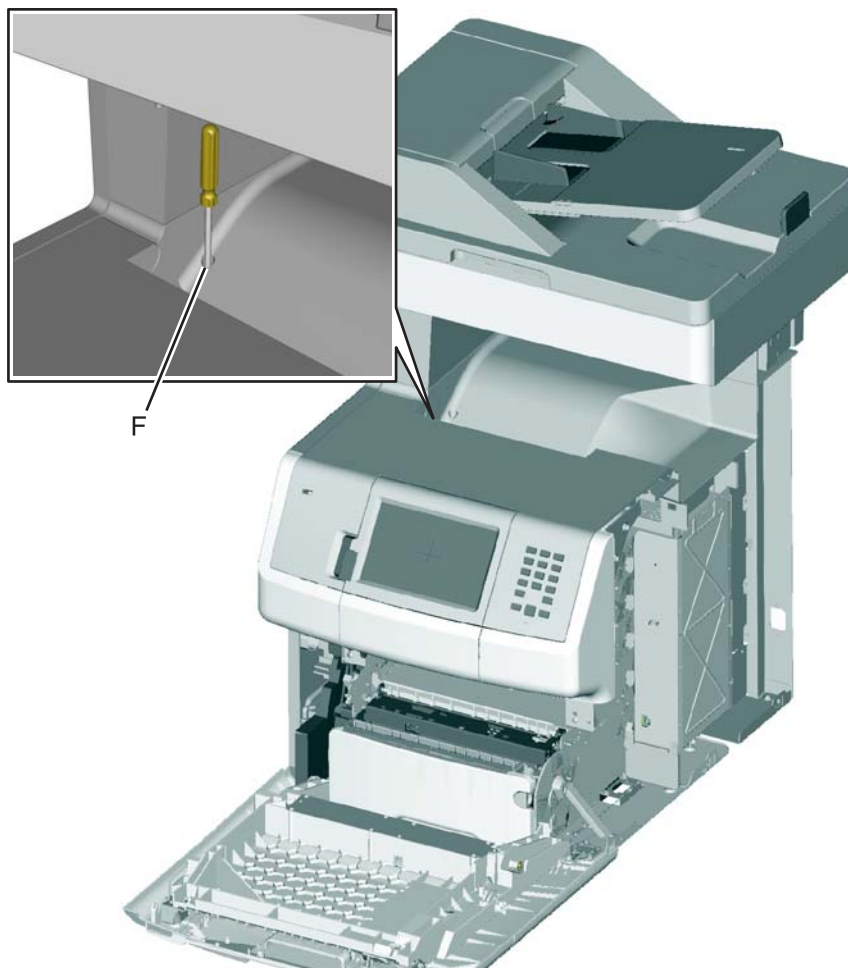

If the top right alignment marks are lower than the top left alignment marks, rotate the alignment screw counterclockwise a full revolution, and print the Quick Test page. Repeat adjusting the screw and printing the Quick Test page until the top alignment marks are the same distance from the top of the media.

Note: One rotation of the printhead alignment screw equals approximately 0.5 millimeter movement of the top edge print alignment marks.

- f. When the top right and top left alignment marks are both showing and are even on the page, the skew is aligned.

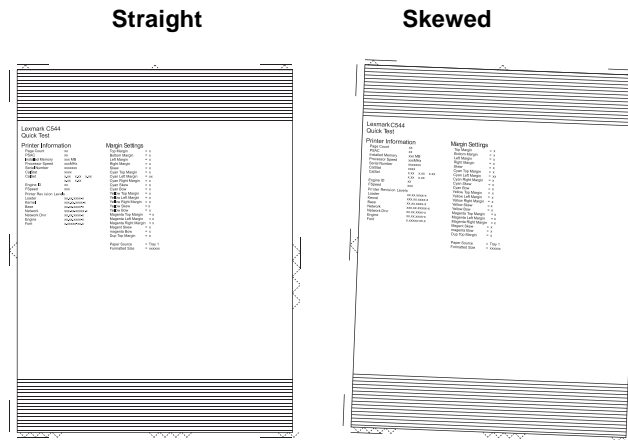

14. Tighten the printhead mounting screws.
- Turn off the printer.
 - Disconnect the power cord from the electrical outlet.
 - Disconnect the transfer module cable.
 - Press the two tabs on either side of the transfer module, and lift out the transfer module with the photoconductor units in place.
 - Remove all of the toner cartridges.
 - Tighten the printhead mounting screws in the following order: G1, G2, and G3.

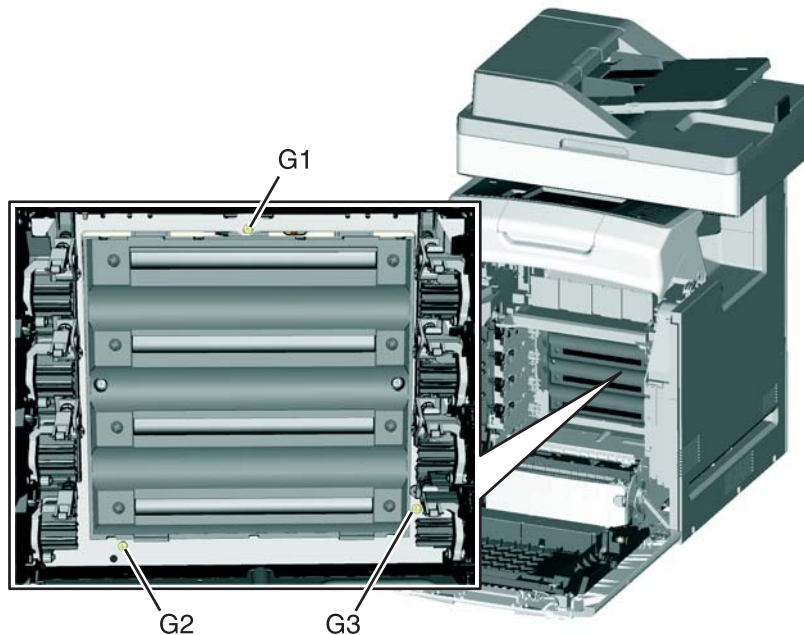

- Replace the toner cartridges.
- Reinstall the transfer module and the photoconductor units.
- Connect the transfer module cable.

Registration (black)

Top Margin

1. Reconnect the power cord to the electrical outlet, but do not turn on the printer yet.
2. Enter Diagnostic mode (press and hold **3** and **6**, turn on the printer, and release the buttons when the progress bar appears).
3. Touch **REGISTRATION**.

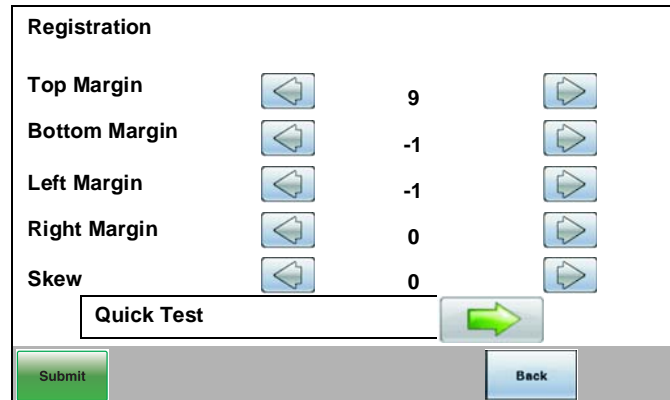

4. Touch **Quick Test**.

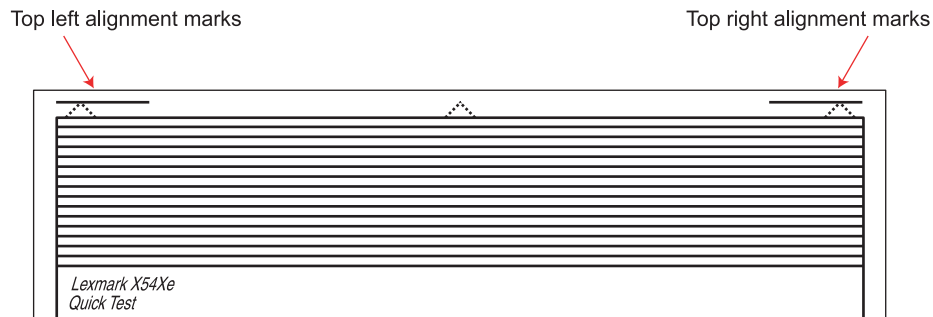

5. Beside **Top Margin**, use the arrows to change the values.
 - a. Adjust the values until both top alignment marks are on the top edge of the print.
 - The right arrow increases the value and moves the top alignment marks down the page.
 - The left arrow decreases the value and moves the top alignment marks up the page.
 - b. Touch **Submit** to save the value, and then touch **Registration** to return to the Registration menu.
6. Print the Quick Test page, and check the top alignment marks. Repeat adjustment of the top margin and printing of the Quick Test page until top margin is set.

Bottom Margin

1. Adjust the bottom margin until the points of the bottom margin alignment marks are visible and touching the edge of the paper.

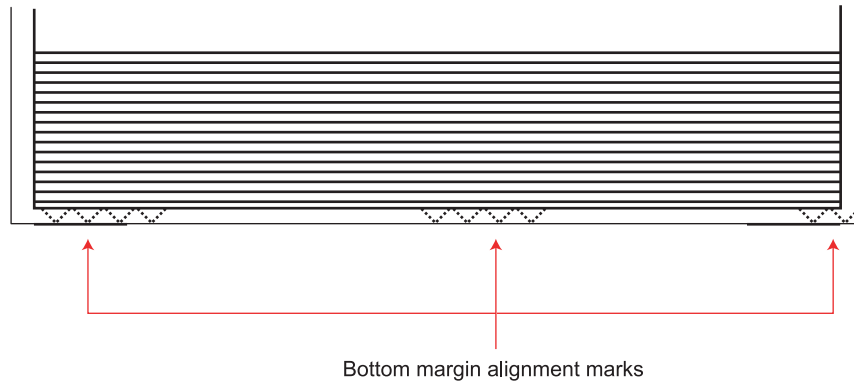

- The right arrow increases the value and moves the bottom alignment marks up the page.
 - The left arrow decreases the value and moves the bottom alignment marks down the page.
2. Touch **Submit** to save the value.
 3. Print the Quick Test page, and repeat this process until the bottom margin is adjusted.

Left Margin

1. Adjust the left margin until the points of the left alignment marks touch the edge of the page.

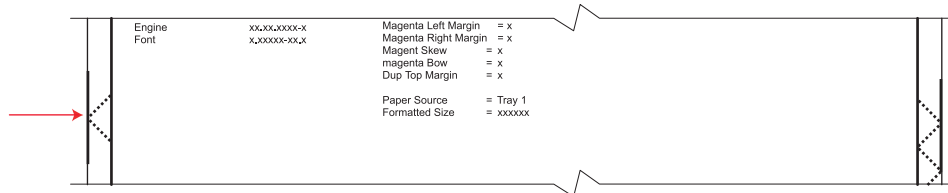

- The right arrow increases the value and moves the left side alignment marks to the right.
 - The left arrow decreases the value and moves the left side alignment marks to the left.
2. Press **Submit** to save the value.
 3. Print the Quick Test page, and check the left alignment marks each time until you are satisfied.

Right Margin

1. Adjust the right margin until the points of the left alignment marks touch the edge of the page.

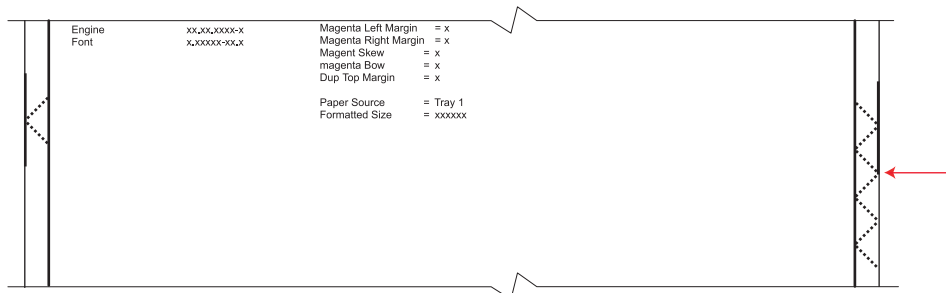

- The right arrow increases the value and moves the right side alignment marks to the left.
 - The left arrow decreases the value and moves the right side alignment marks to the right.
2. Touch **Submit** to save the value.
 3. Print the Quick Test page, and check the results. Repeat if necessary.
 4. When the registration is complete, proceed to the color alignments.

7. Determine the line under Fine Adjustment that is closest. If the value is beyond the Fine Adjustment scale, use either of the Coarse Adjustment scales.

Top (T) Coarse Adjustment

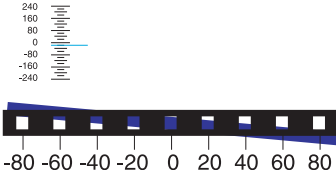

Top (T) Fine Adjustment

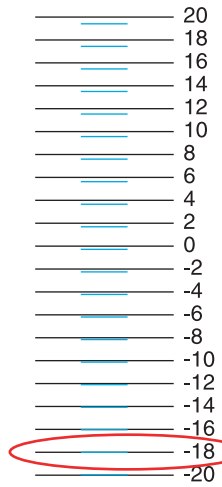

If the alignment is not close enough to use the fine adjustment, get close to the ideal value by using the coarse adjustment marks. Select the block that is most filled by the color on the left, or approximate if none of the blocks are completely filled, and enter it for the new value. Reprint the quick test page, and then use the fine adjustment.

First, locate the line of the color that you are aligning that lines up best with the scale line. In this example, it is -18. If none of the colored lines match up, use the coarse adjustment to get close, reprint this page and then use the fine adjustment.

8. Enter the number determined from the Fine Adjustment scale or the Coarse Adjustment scales on the part of the page for the “T” value. The current value is automatically entered on the sheet. At this point, it should be zero.

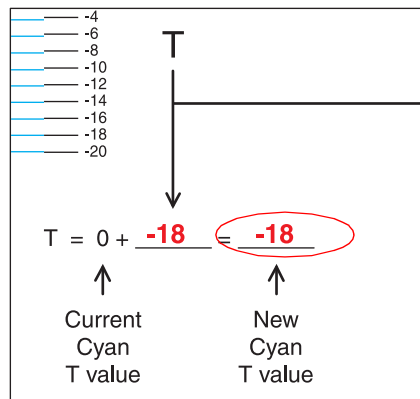

$T = 0 + (-18) = -18$

Current Cyan T value New Cyan T value

9. Enter the “New Cyan T value” on the operator panel using the left and right arrows, and press **Submit** to save the value.
10. Reprint the Quick Test, and evaluate whether you are at zero changes.

11. Repeat this process for skew (Z). Don't forget to subtract the T value and add the current cyan Z value to obtain the new skew (Z) value.
An example is shown below:

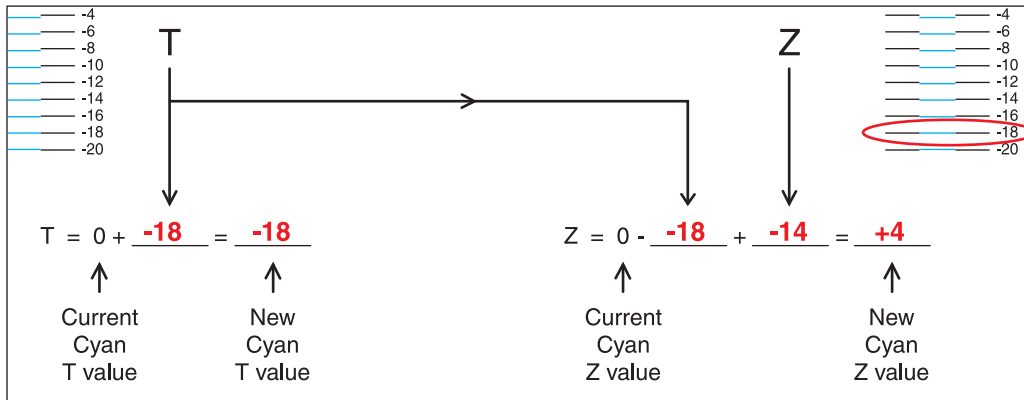

12. Continue to follow the directions on the bottom of the first page to find the Cyan Top Margin (T), the Skew (Z), and on the second page of the Quick Test page, the Left Margin (L), Right Margin (R), and Bow (P).

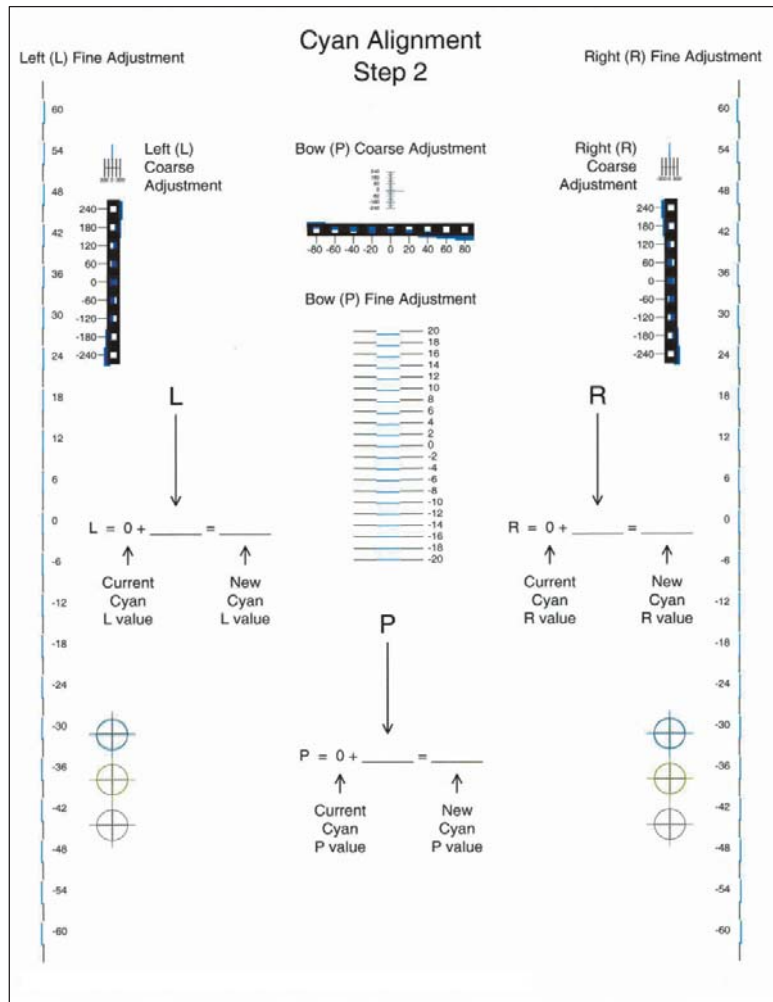

13. Repeat steps 2 through 11 for yellow and magenta.
Note: Start each color group by setting the Top Margin, Left Margin, Right Margin, Bottom Margin, Skew, and Bow to zero.

Printer removal procedures

Precautions to take before maintenance work

Do not implement any operation, removal, or modification and so on, which is not presented in this manual.



1. Turn the printer power off and unplug the power cable from the outlet prior to starting removals or checks.
2. Prior to starting any repairs, read and understand the warnings in this manual.
 - High temperature
 - High voltage
 - Laser radiation
3. Confirm the direction of all parts and screw lengths during removal/replacement.
4. Utilize the proper cleaning procedures/solvents during maintenance.
5. Confirm that all parts and covers are properly installed and assembled prior to starting the print test.

Multifunction printer removals

Front access cover assembly removal

See Front access cover assembly for the part number for the models you need on [page 7-3](#).

1. Remove the paper tray.
2. Disconnect the transfer module cable (A).
3. Press the two tabs (B) to release the front access door cover assembly.
4. Press the two tabs (C) on either side of the transfer module, and lift out the transfer module.
Note: Leave the photoconductor units on the transport belt when removing.

Warning: To avoid damaging the photoconductor drum, hold the photoconductor units by their handle and place the photoconductor units on a clean surface. Never expose the photoconductor units to light for a prolonged period of time. See [“Handling the photoconductor unit” on page 4-2](#) for additional information.

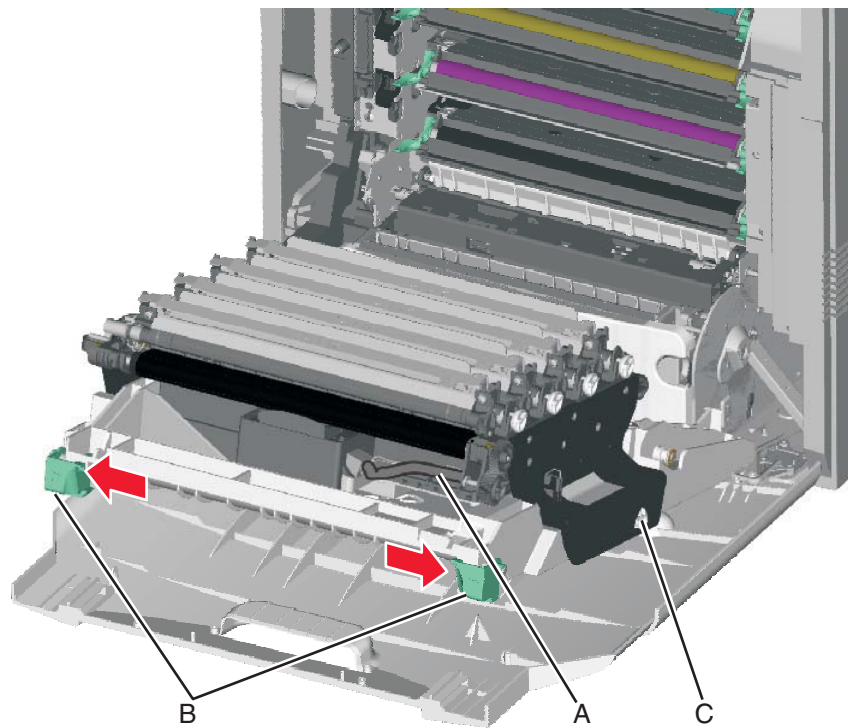

5. Looking down at the keyed end of the restraint (D), twist the end clockwise, slide the restraint upward through the slit (E), and slip the end of the restraint through the keyed hole (F). Repeat for the other side.

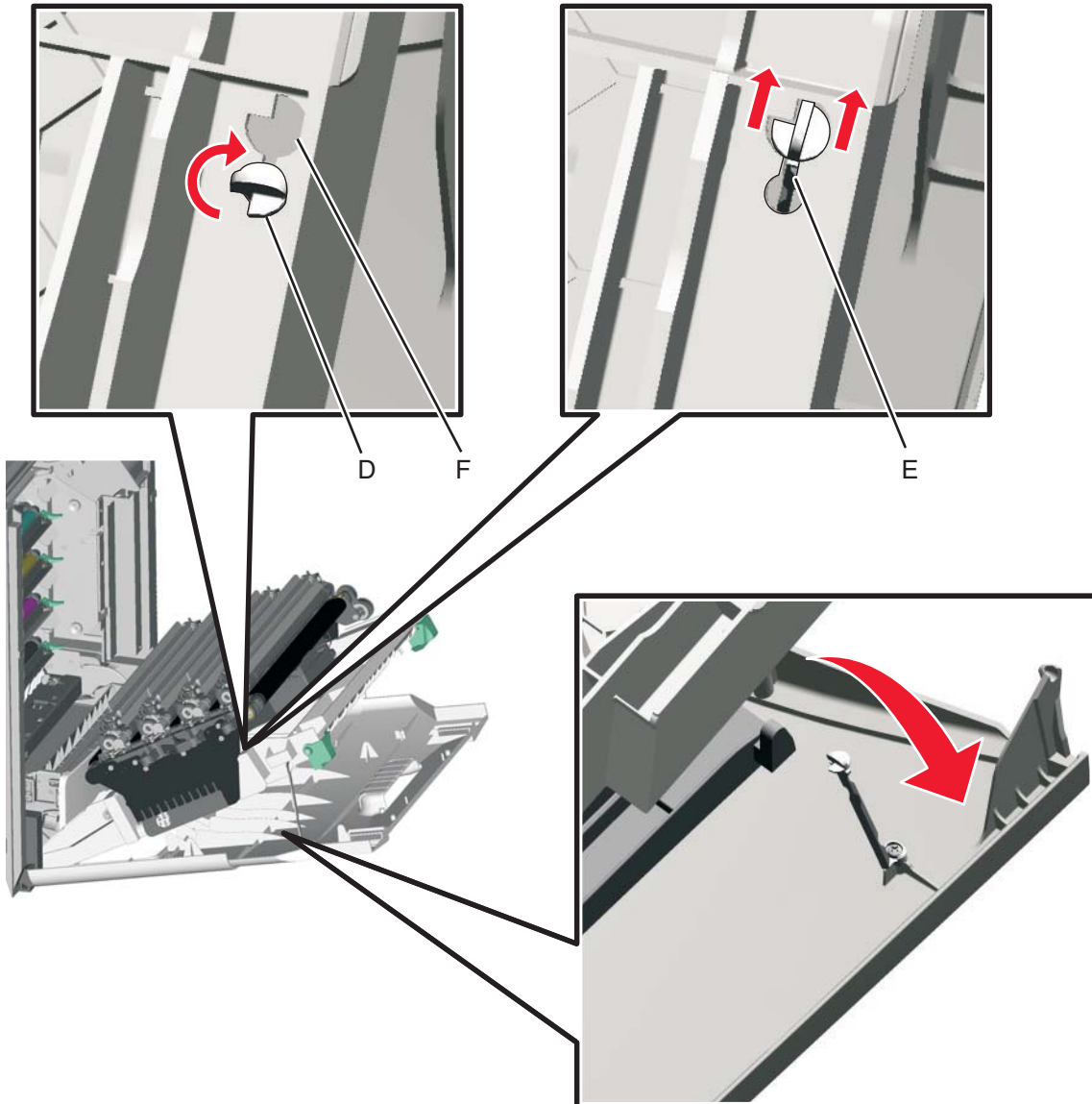

6. Close the front access door assembly.
7. Remove the two screws (G) that attach the pivot pin to the front access door cover assembly.
8. Remove the bracket (H).

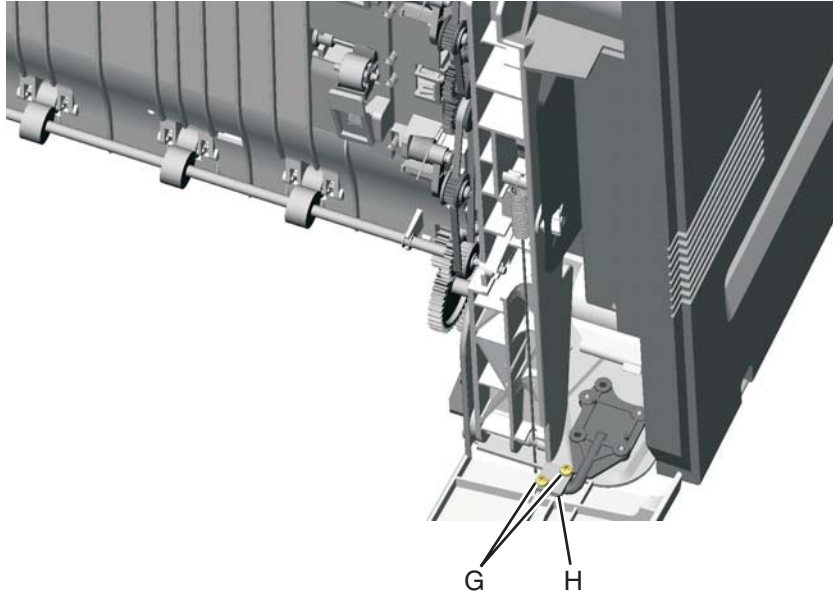

9. Remove the front access cover assembly.

Left cover removal

See **“Left cover” on page 7-3** for the part number.

Remove the left cover with the left door cover attached.

1. Remove the rear cover. See **“Rear cover removal” on page 4-37**.
2. Remove the waste toner assembly. See **“Waste toner assembly removal” on page 4-186**.
3. Open the top access cover.
4. Open the front access cover.
5. Remove the screw on the inside (A).

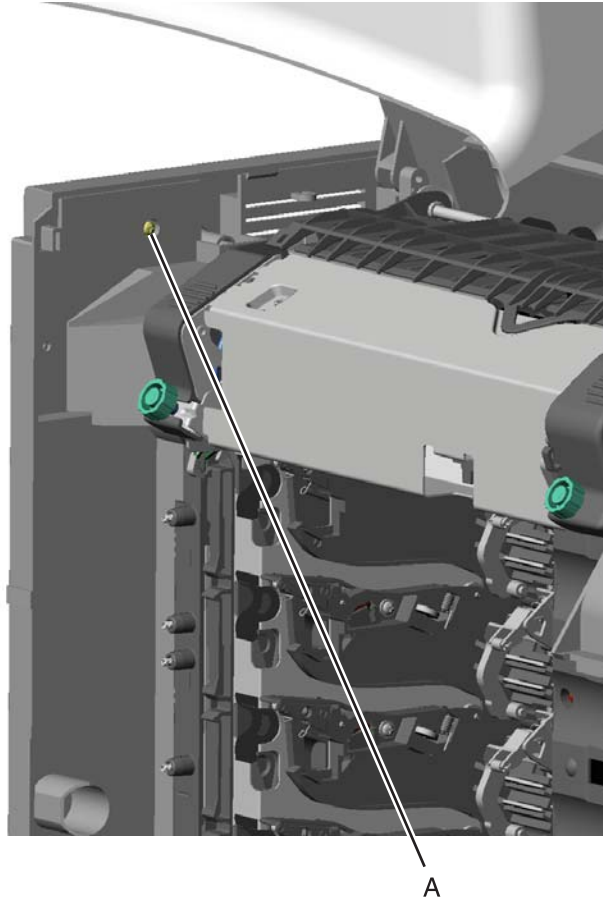

6. Remove the two screws (B).
7. Press the locking tab (C), slide the cover down.
8. Grasp the side at the point shown, and disconnect the tab on the upper edge. Push down with your thumb on the outside while pulling up with the fingers to remove the cover.
Warning: Be careful not to damage the two small locking tabs (D).

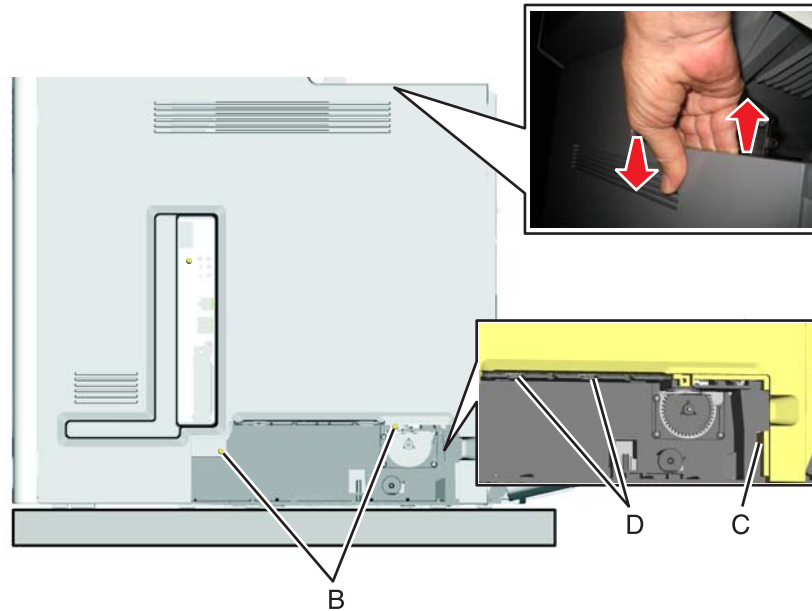

Note: If you are removing the left cover to access another part, leave the left cover and the left door cover attached, and you are done. If you need to replace the left cover FRU, continue with the next step to remove the separate left door cover FRU.

9. Remove the left door cover. See **“Left door cover removal” on page 4-25.**

Left door cover removal

1. Open the left door cover.
2. Lift up to disengage the hinges.

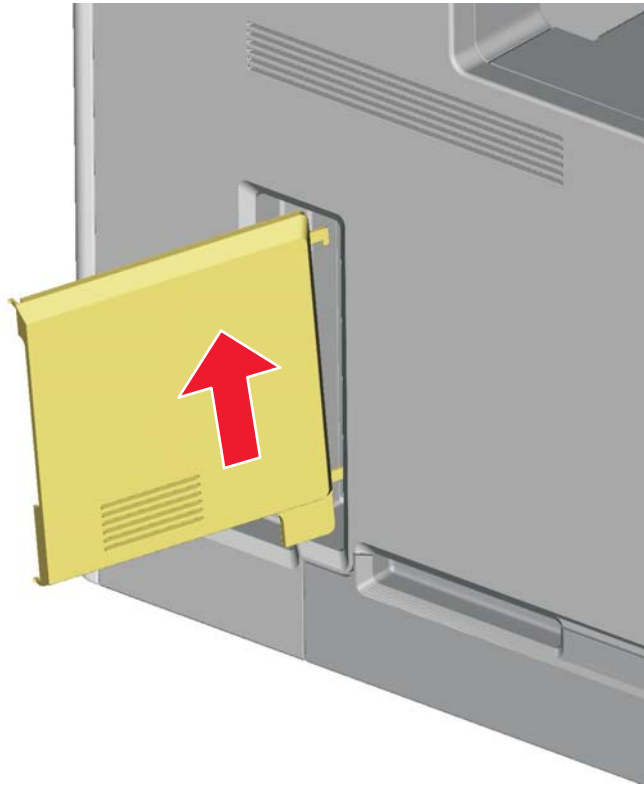

3. Remove the left door cover.

Operator panel assembly removal

See **“Operator panel assembly, with card”** on page 7-3 for the part number.

1. Remove the top access cover assembly. See **“Top access cover assembly removal”** on page 4-41.
2. Place the top access assembly on a soft link-free cloth with the touchscreen facing down.
3. Remove the six smaller screws (A) securing the position guide.

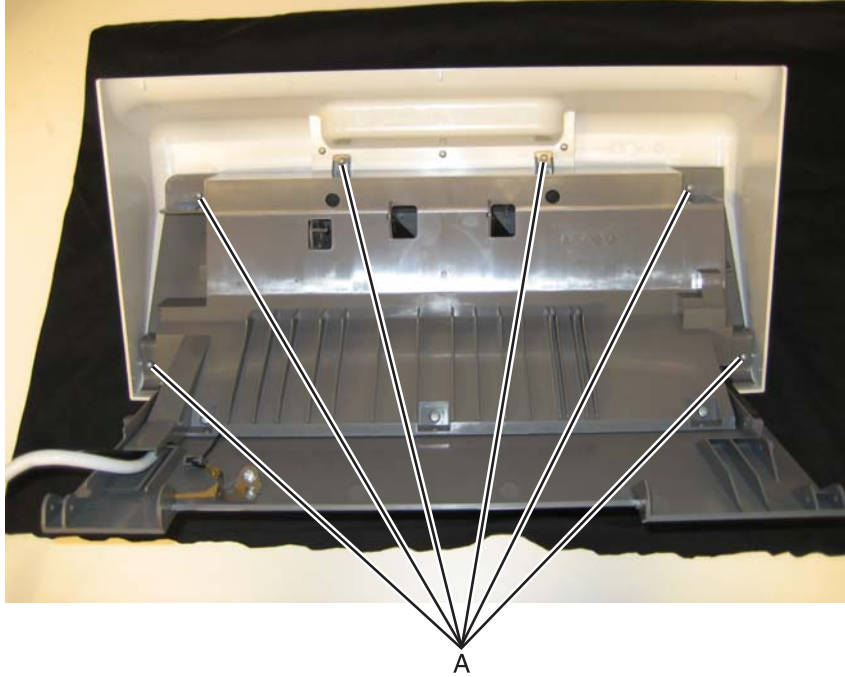

4. Remove the five larger screws (B) and the two smaller screws (C).

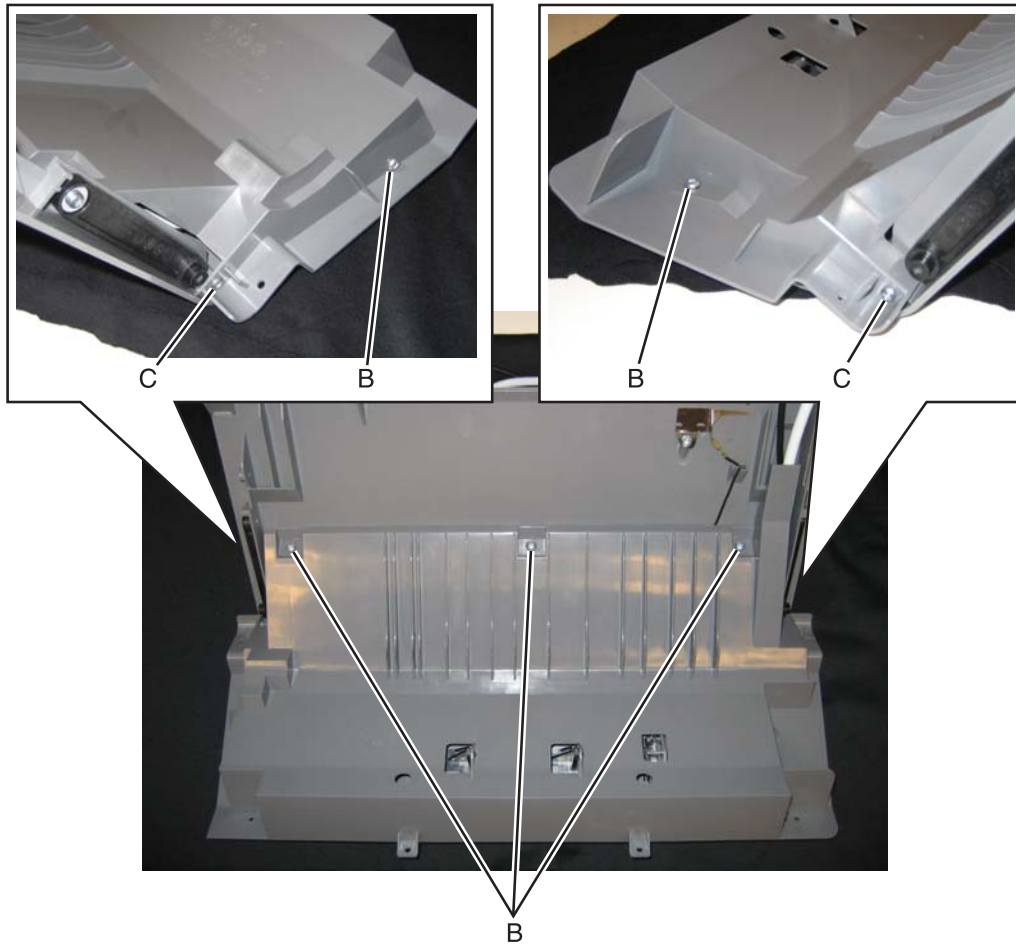

5. Lift the position guide, so you can access the cables.
6. Flip open the lock (D) on the wide ribbon cable, and remove the cable from the connector.

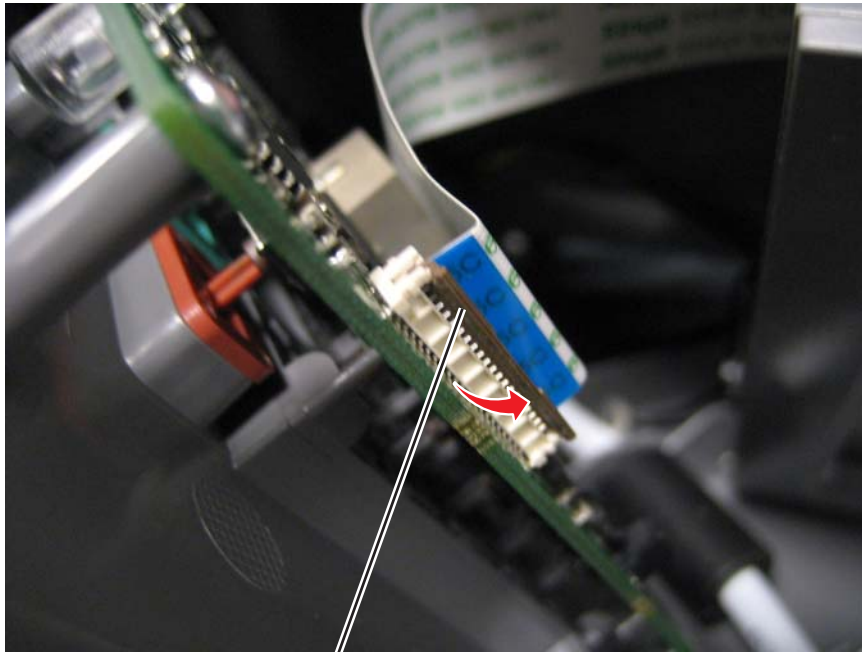

D

7. Disconnect the display cable (E) by pulling it straight out.
8. Remove the screw (F) and disconnect the ground cable.



E

F

9. Remove the position guide.



10. Turn the position guide cover over.
 11. Remove the bezel. See **“Operator panel bezel removal”** on page 4-31.
 12. Rotate the operator panel up, and gently pull the display ribbon cable to the back the through the toroid (G).

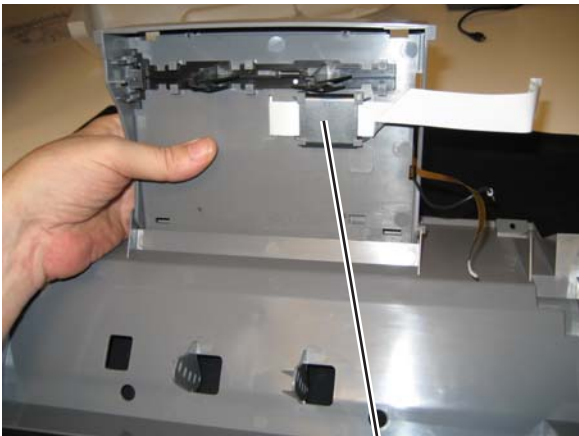

G



13. Remove four screws (H).

Note: Make sure to note the position of the ground cable (J) on the upper right.

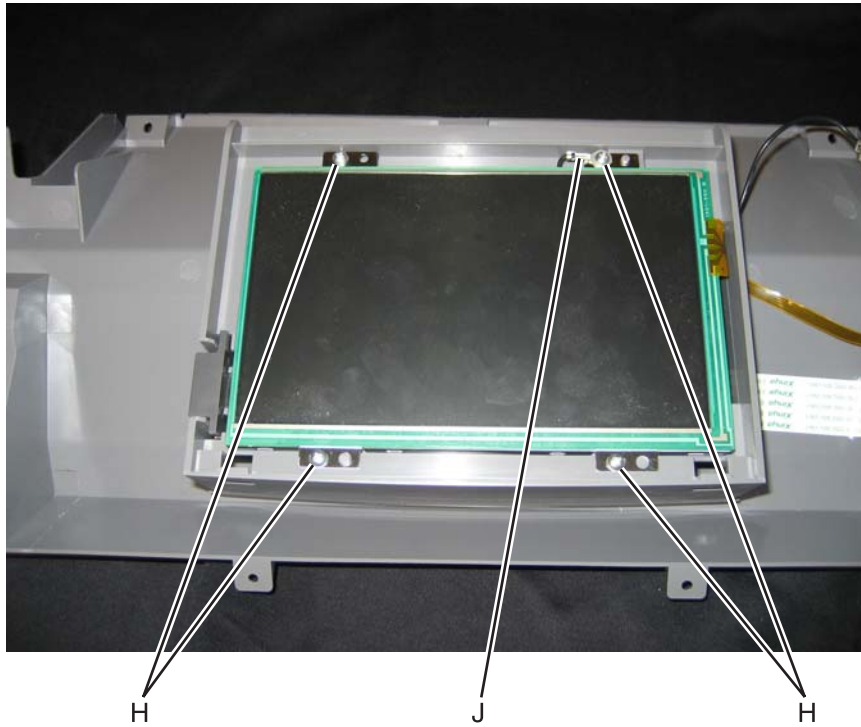
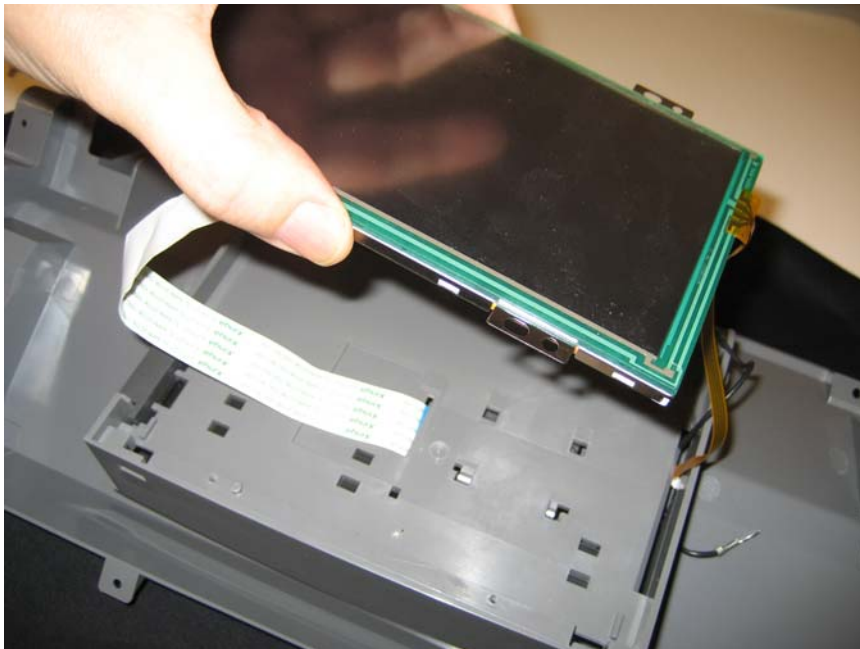
**14.** Remove the operator panel (touchscreen).

Operator panel bezel removal

See Operator panel bezel on [page 7-3](#) for the part number.

1. Rotate the operator panel to its highest position.
2. Using a flathead screwdriver or similar tool, *unsnap* the locking tabs on the upper left and the upper right of the bezel. The tabs on the right and left side will then release.



3. Rotate the bezel down, and remove the bezel.



Installation note: When reinstalling or replacing the bezel, insert the bottom of the bezel first, ensuring that the bezel bottom portion fully seats.

Operator panel buttons removal

1. Remove the top access cover assembly. See **“Top access cover assembly removal”** on page 4-41.
2. Place the top access assembly on a soft link-free cloth with the touchscreen facing down.
3. Remove the six smaller screws (A) securing the position guide.

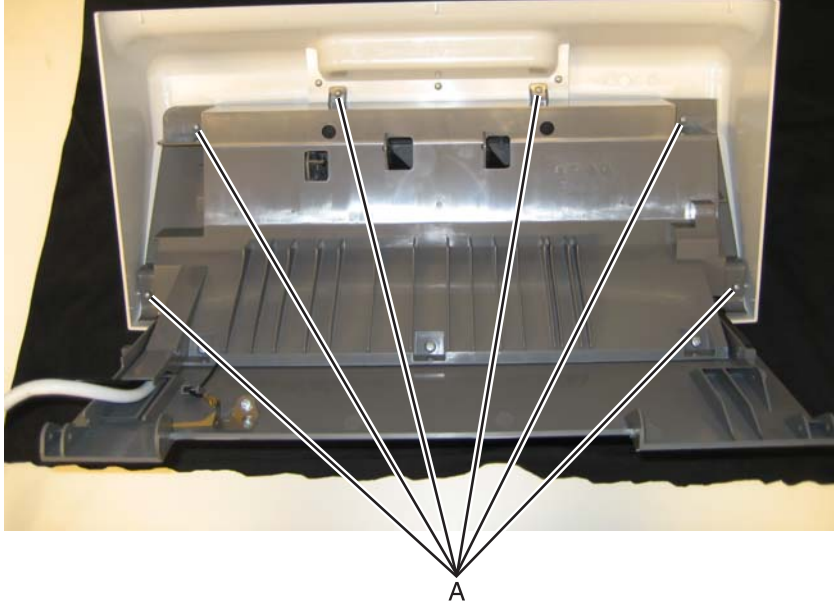

4. Remove the five larger screws (B) and the two smaller screws (C).

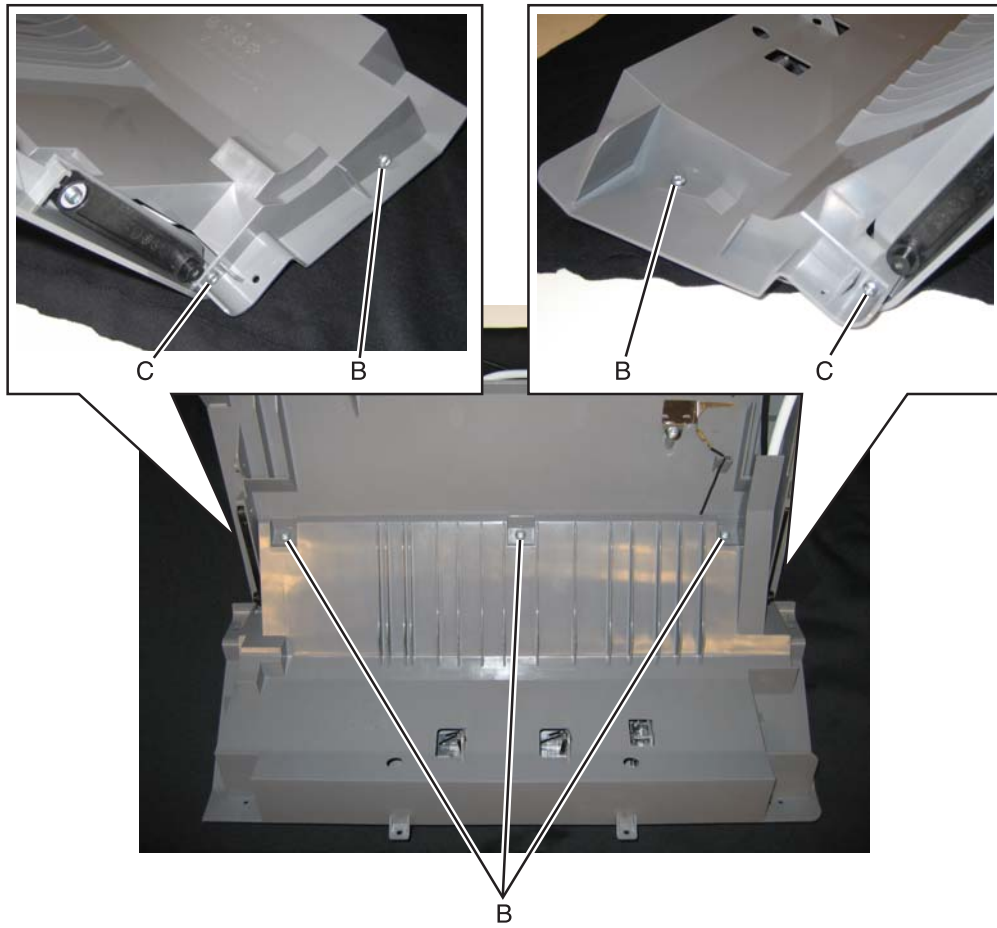

5. Lift the position guide, so you can access the cables.
6. Flip open the lock (D) on the wide ribbon cable, and remove the cable from the connector.

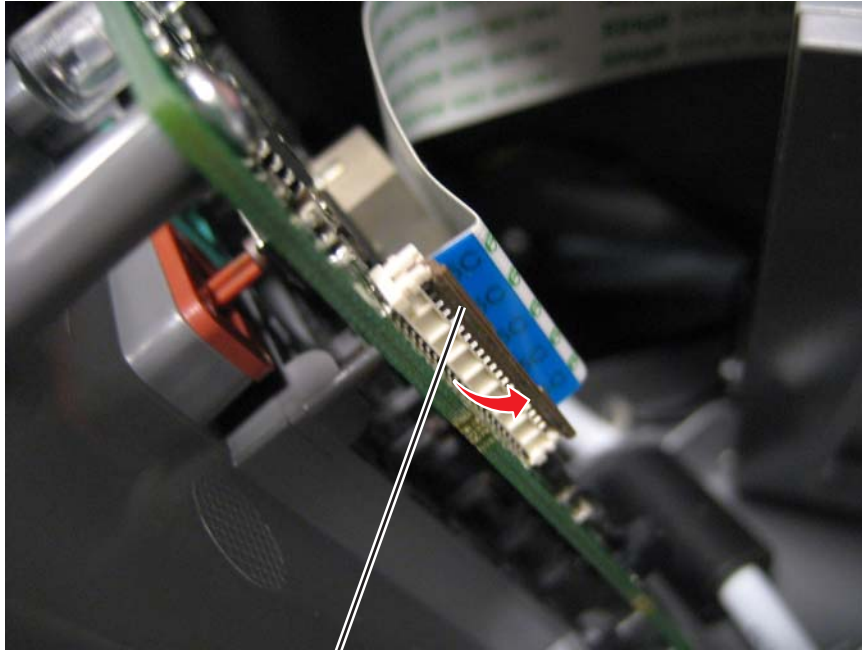

D

7. Disconnect the display cable (E) by pulling it straight out.
8. Remove the screw (F) and disconnect the ground cable.



E

F

9. Remove the three screws (G) from the operator panel card.

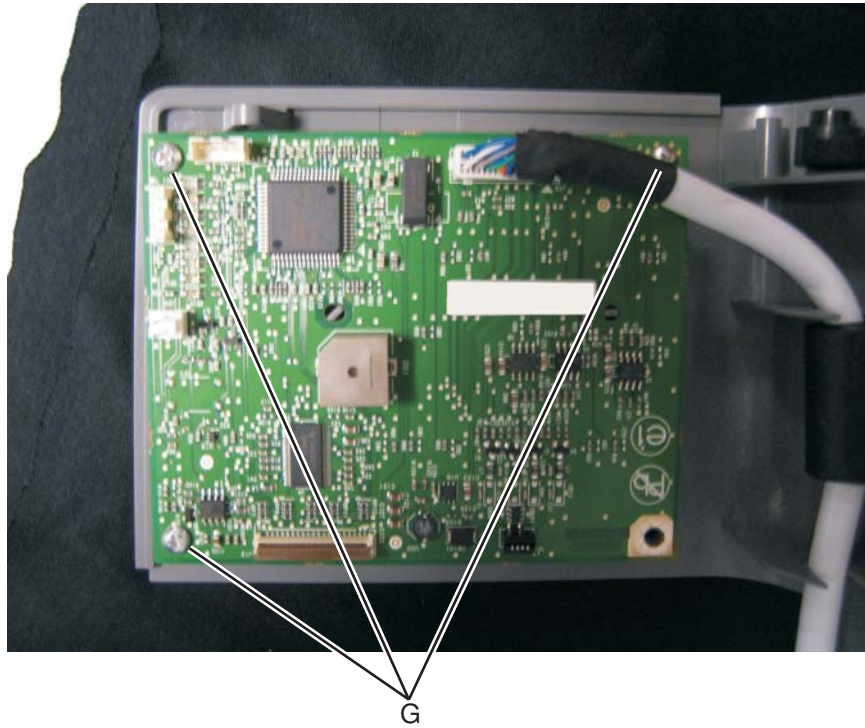

10. Move the UICC card out of the way to access the buttons.



11. Remove the button or buttons that you need to replace.

Output bin extension cover removal

See **“Output bin extension cover”** on page 7-3 for the part number.

Lift to remove the output bin extension cover.



Rear cover removal

1. Remove the four screws (A).



2. Lift up to disengage the two tabs (B).

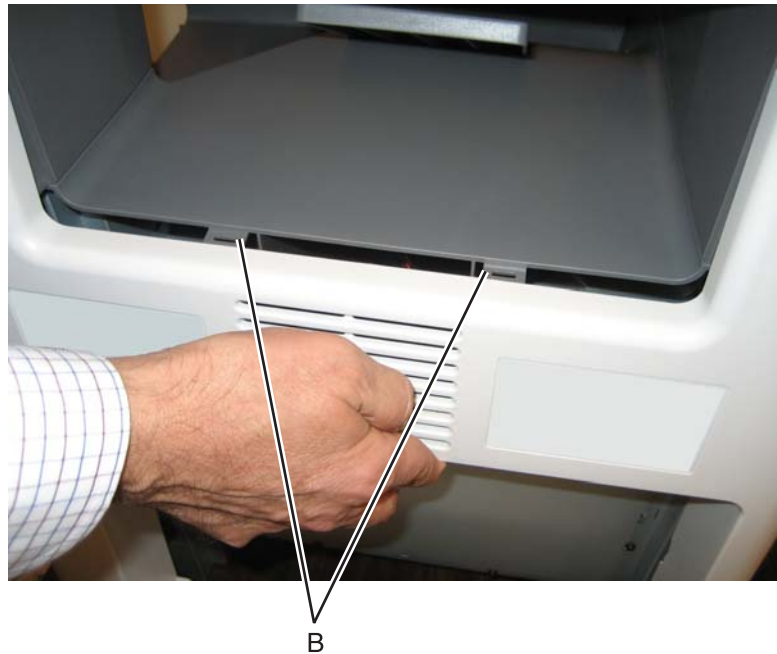

Note: If you are removing the rear cover to access another part, leave the cooling fan filter in place, and you are done. If you need to replace the rear cover continue with the next step to remove the separate cooling fan filter.

3. Remove the cooling fan filter. See **“Cooling fan removal”** on page 4-65.

Rear frame cover removal

See **“Rear frame cover” on page 7-3** for the part number.

1. **Loosen** the eight screws (A).
2. Lift the rear frame cover, and remove.

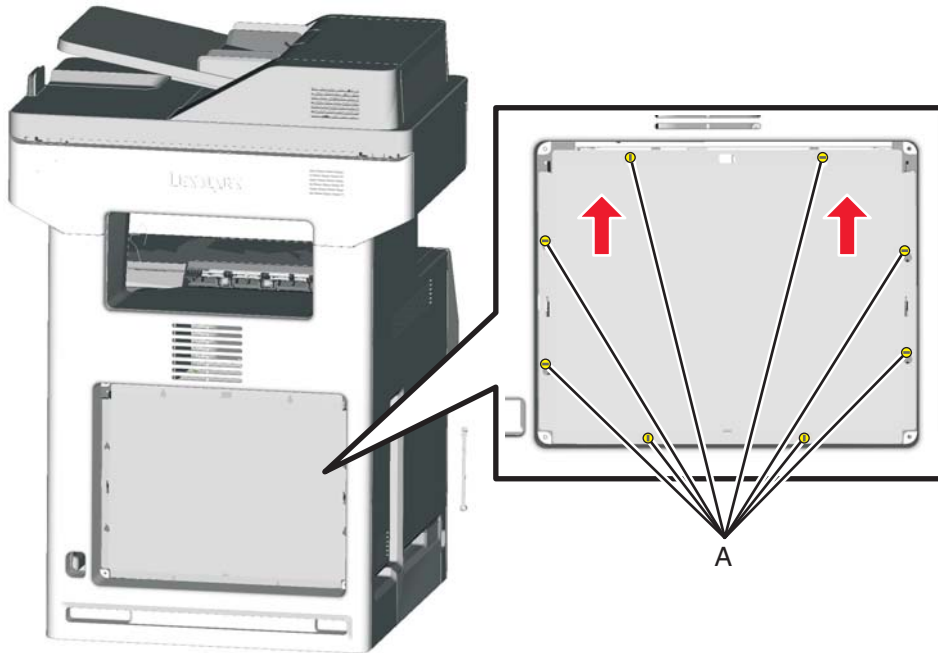

Right cover removal

See **“Right cover”** on page 7-3 for the part number.

1. Remove the rear cover. See **“Rear cover removal”** on page 4-37.
2. Open the top access cover.
3. Open the front access cover.
4. Remove the plastic screw on the front (A).

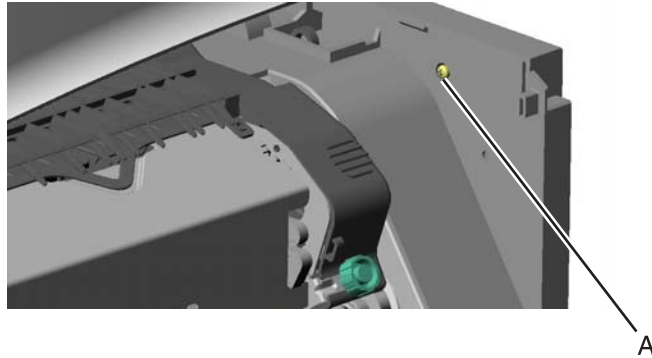

5. Remove the two black screws on the front (B).



6. Remove the three screws (C).

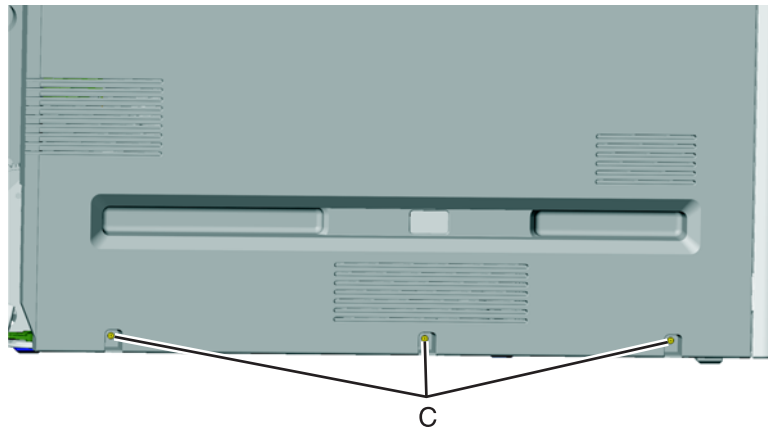

7. Pull up on the rear of the right cover, and then press down at the indicated location to disengage the tab.

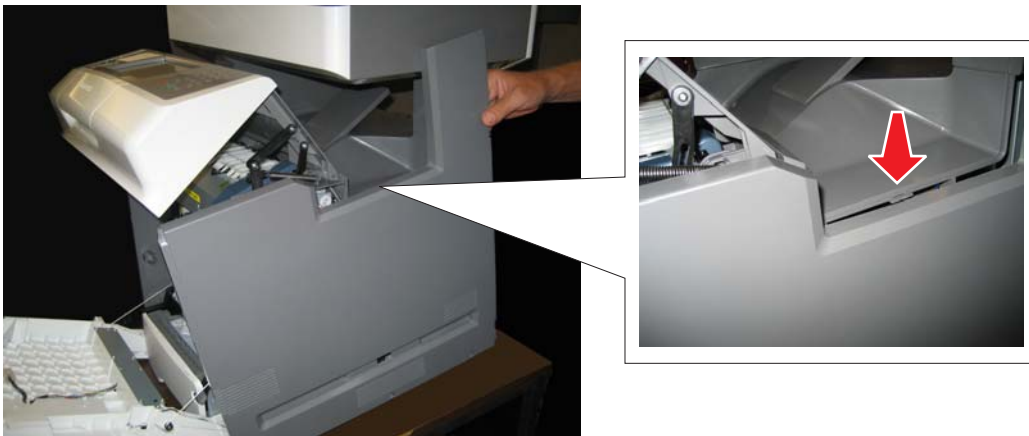

Top access cover assembly removal

See **“Top access cover assembly” on page 7-3** for the part number.

1. Remove the right cover. See **“Right cover removal” on page 4-39**.
2. Remove the rear frame cover. See **“Rear frame cover removal” on page 4-38**.
3. Disconnect the operator cable connector at JOPP1 (A) and the USB connector cable in connector JFMUSB1 (B) on the system board.
4. Remove the USB cable from the cable restraints (C).

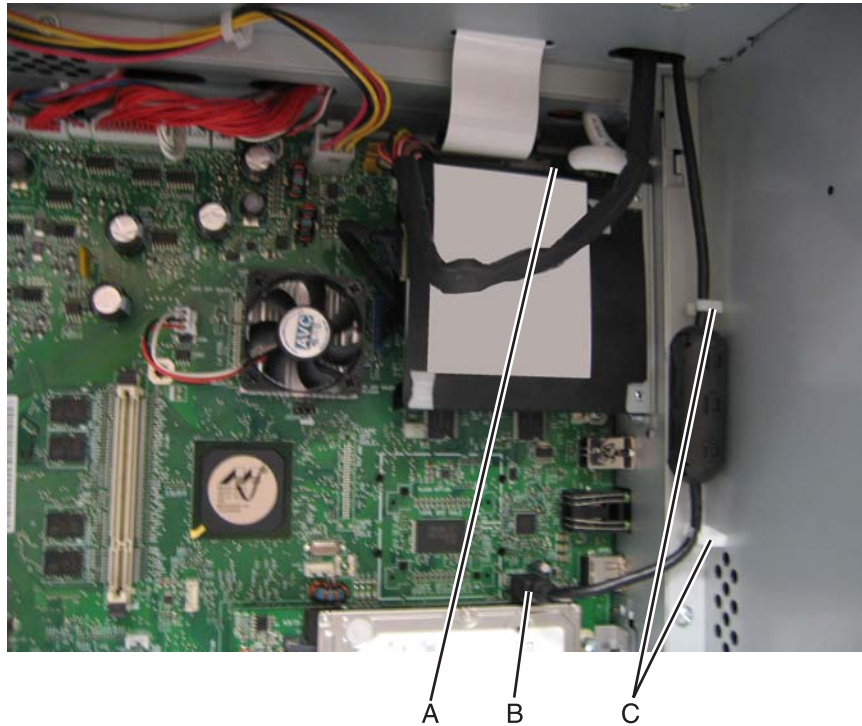

5. Open the three clips on the toroid to remove it from the USB cable.
Note: Be sure to re-install the toroid when the top access cover is replaced.

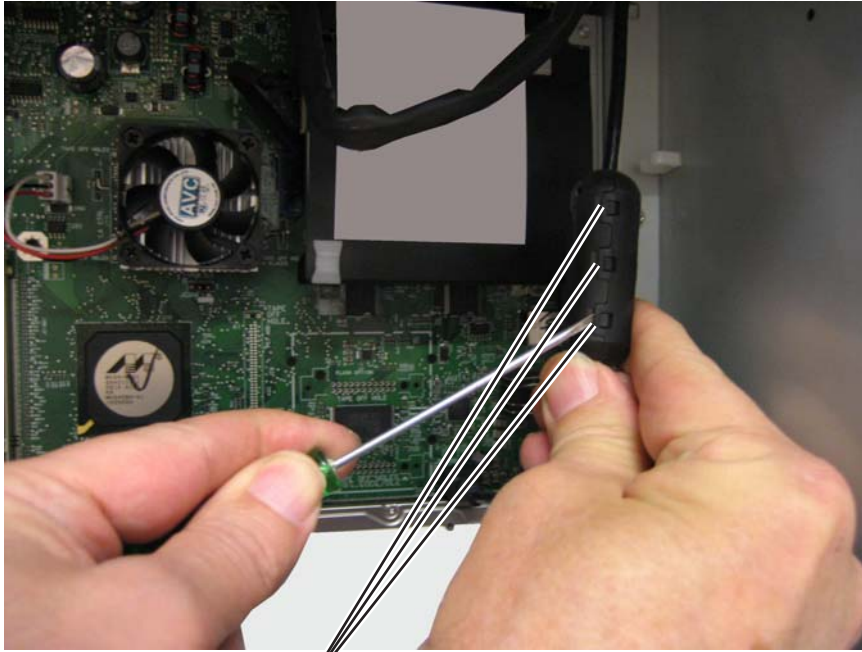

D

6. Remove the cables through the openings (E) in the system board frame.



E

7. Remove the UICC cable from the two cable clamps (F), and the USB cable from the two clamps (G) above the system board.
8. Open the two clips on the toroid (H) on the UICC.

Note: Be sure to retain the toroid, and reinstall it on the cable when you install the top access cover.

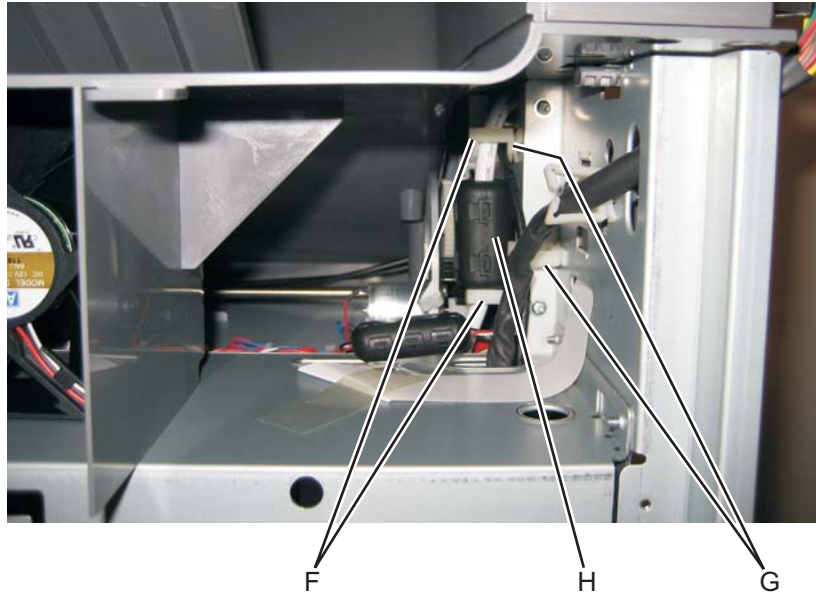

9. Remove the cables through the frame, over the cartridge fan, through the cable clamps (J), and through the frame towards the front of the MFP.

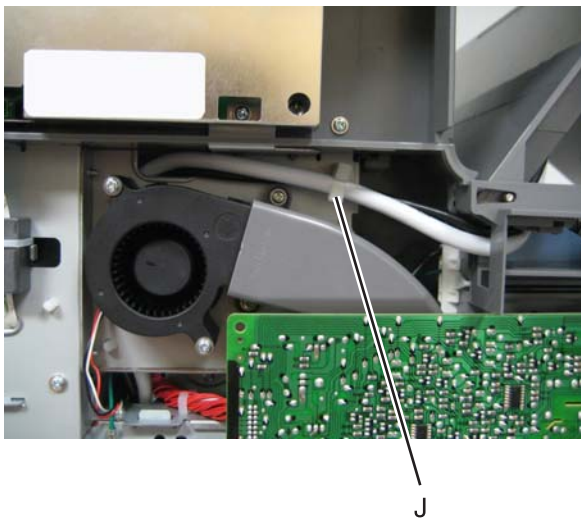

10. Remove the fuser. See **“Fuser assembly removal”** on page 4-94.

11. Remove one screw (K) on the left side and two screws (L) on the right side, that secure the links.



K



L

12. Rotate the left and right pivots (M) until they are upright, and then remove them.

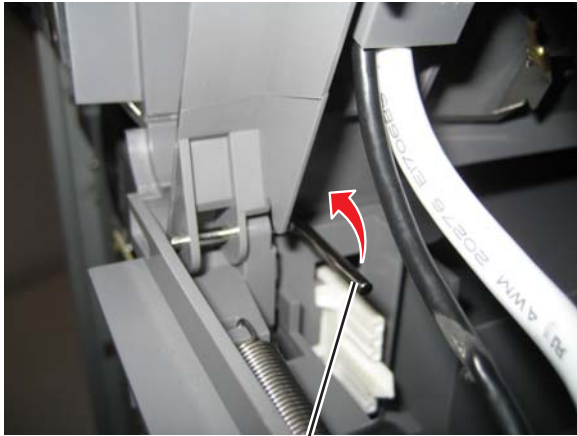

M



M

Note: If you are removing the top access cover to access another part, leave the top access cover and the operator panel bezel attached, and you are done. If you need to replace the top access cover FRU, continue with the next step to remove the separate operator panel bezel FRU.

13. Remove the operator panel bezel. See **“Operator panel bezel removal”** on page 4-31.

Top cover assembly removal

1. Remove the top access cover. See **“Top access cover assembly removal”** on page 4-41.
2. Remove the flatbed scanner. See **“Flatbed scanner removal”** on page 4-240.
3. Remove the LVPS.

Note: Make sure you note the routing of the cable for reinstallation. The cable should pass through the cable restraint (A)

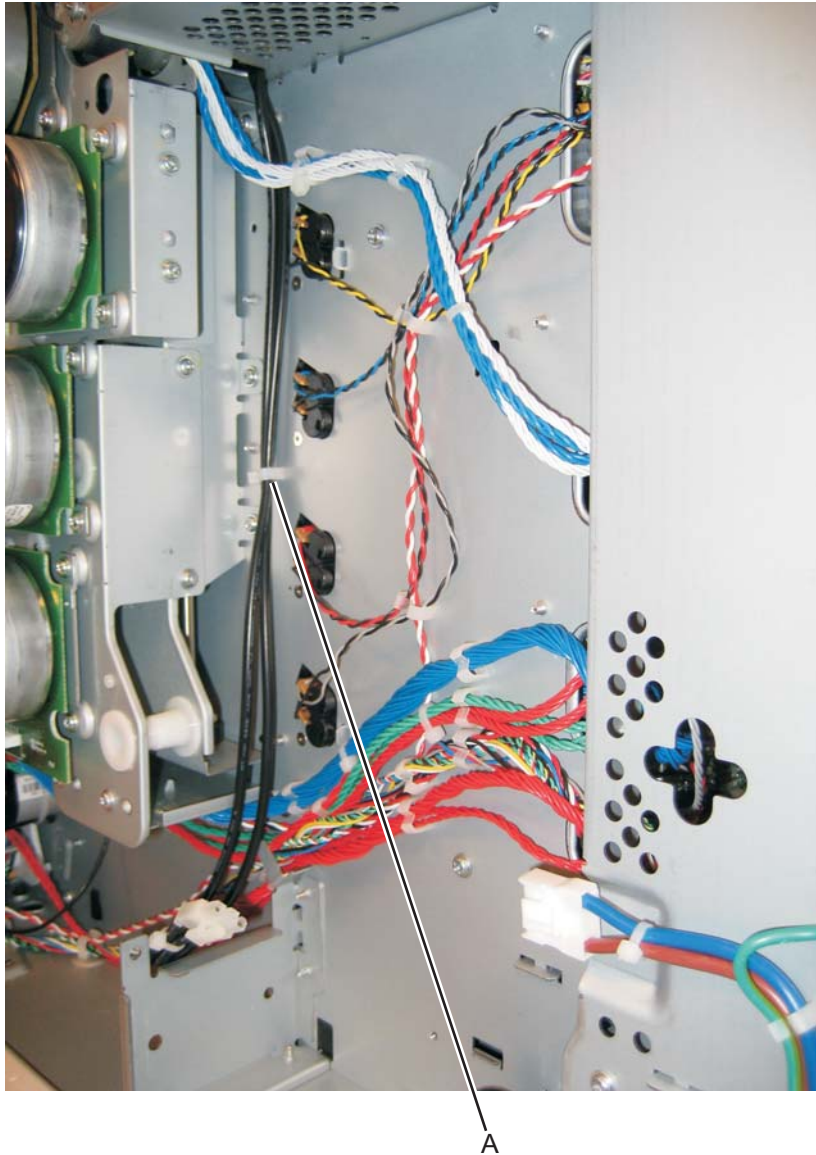

4. Disconnect the cables in connectors JBIN1 (A), JFDS1 (B), JFAN1 (C), and JFUSER1 (D), on the system board.
5. Remove the output bin sensor cable (A) and the feed through sensor cable (B) through the side of the frame (E).

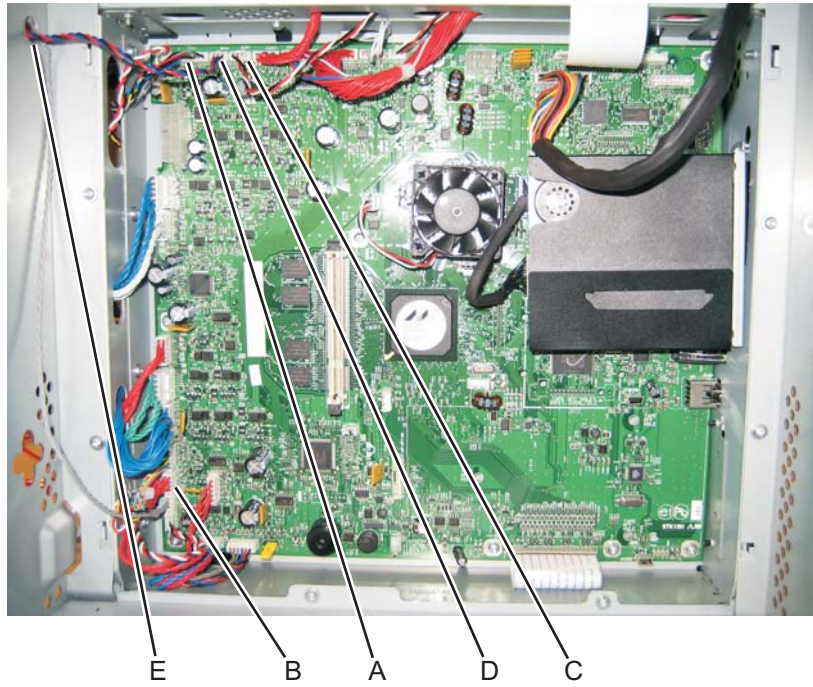

6. Remove the six screws (F).

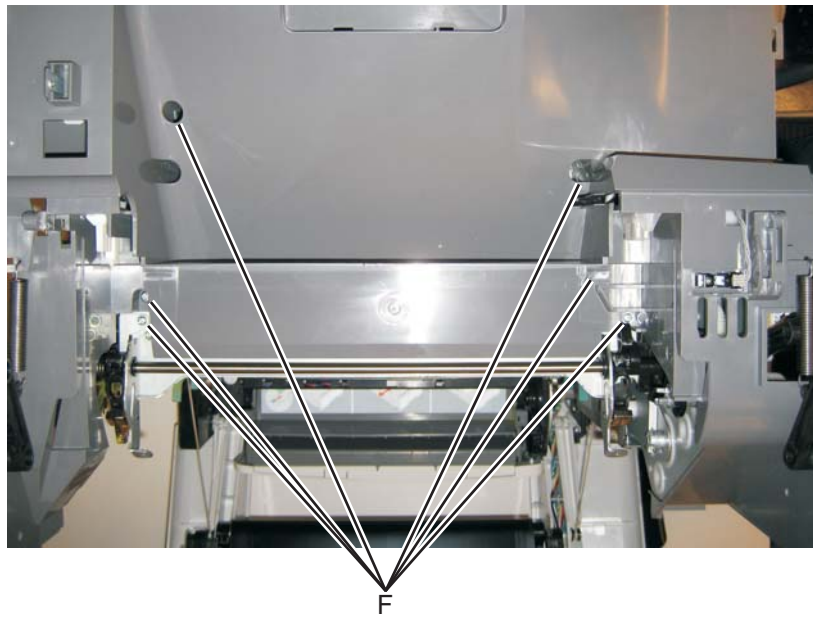

7. Remove the screw (G) in front.

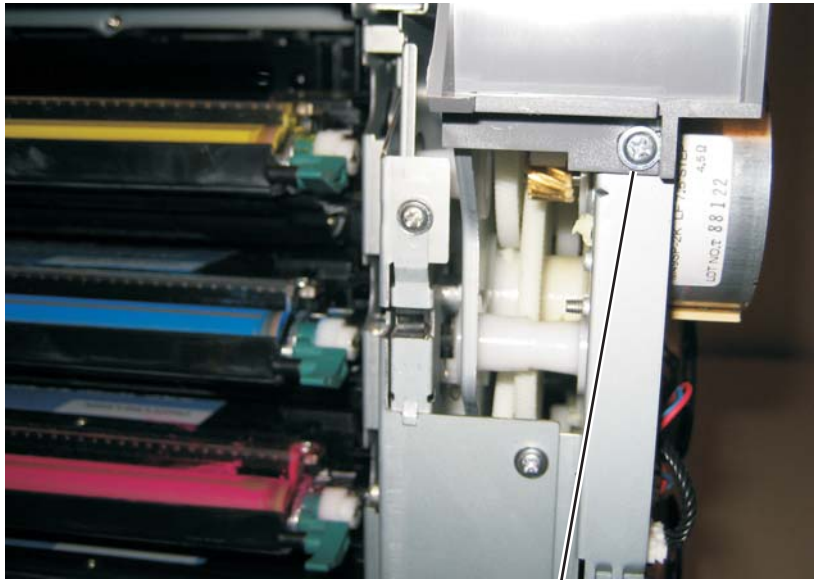

G

8. Remove the ground screw (H) on the right side, and remove the ground cable from the cable restraint (J).

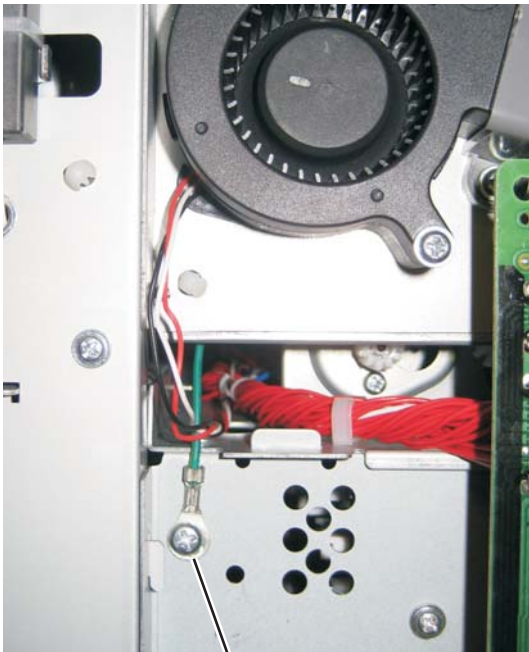

H

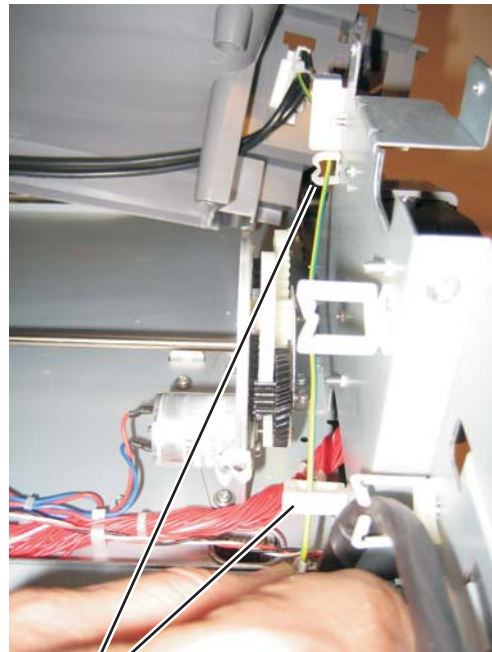

J

Note: If you are removing the top cover to access another part, leave the cooling fan in the top cover, and you are done. If you need to replace the top cover FRU, continue with the next step to remove the separate output bin extension cover FRU.

9. Remove the output bin extension cover. See **“Output bin extension cover removal”** on page 4-36

5 V interlock switch cable removal

See “5 V interlock switch” on page 7-7 for the part number.

1. Remove the EP drive assembly. See “Electrophotographic (EP) drive assembly removal” on page 4-70.
2. Disconnect the cable in connector at JINT1 (A) on the system board.

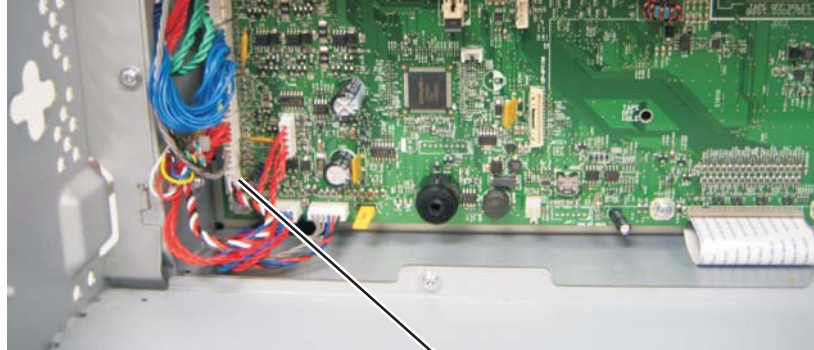

A

3. Open the front access door cover, and remove the screw (B).

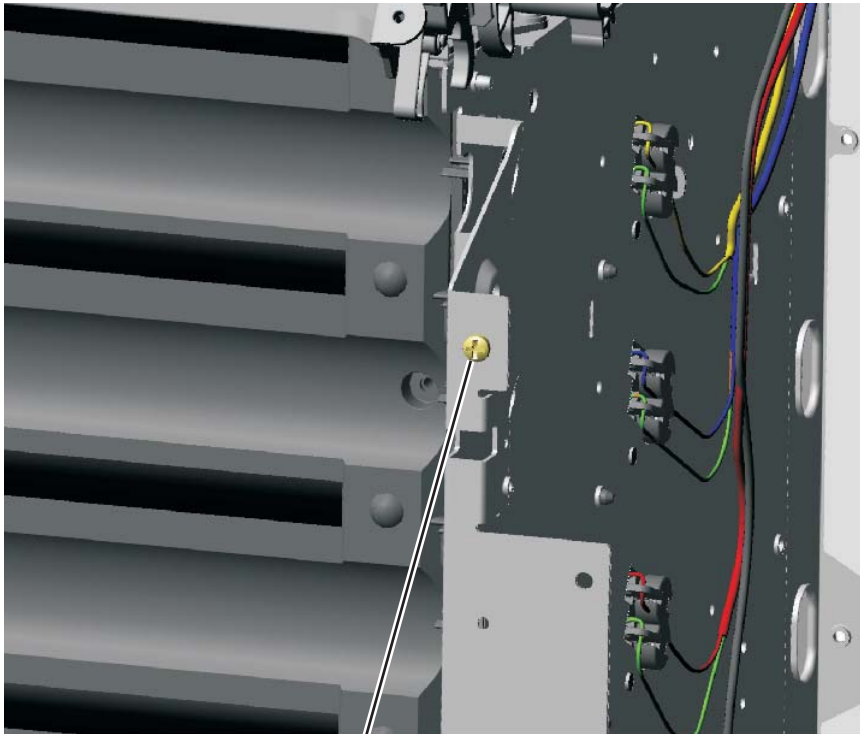

B

4. Remove the cable from the two cable retainers (C).

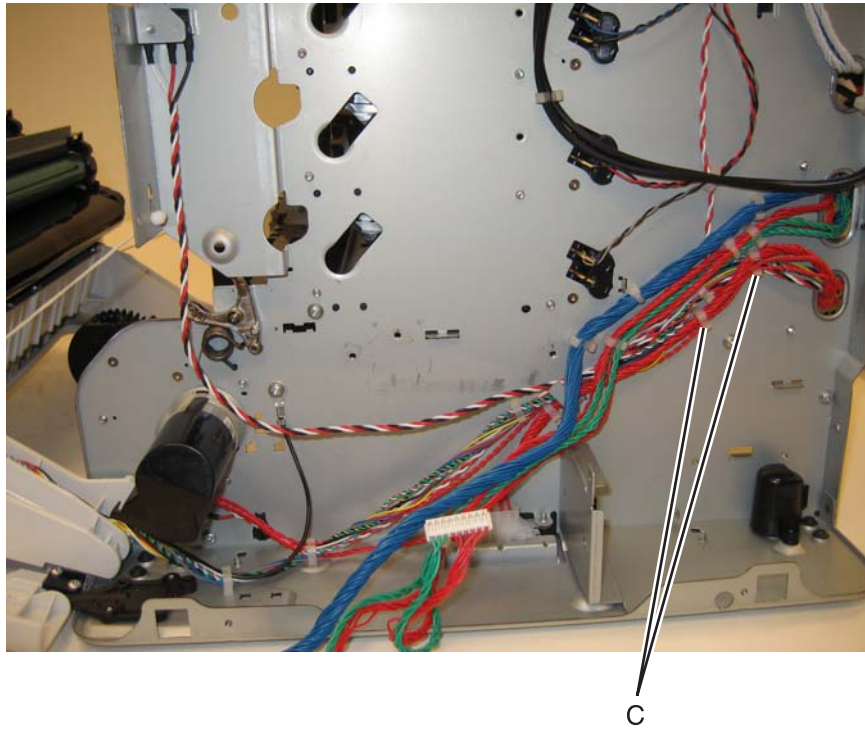

5. Remove the 5 V interlock switch and bracket from the printer.
6. Remove the screw (D), and remove the 5 V interlock switch cable from the bracket.

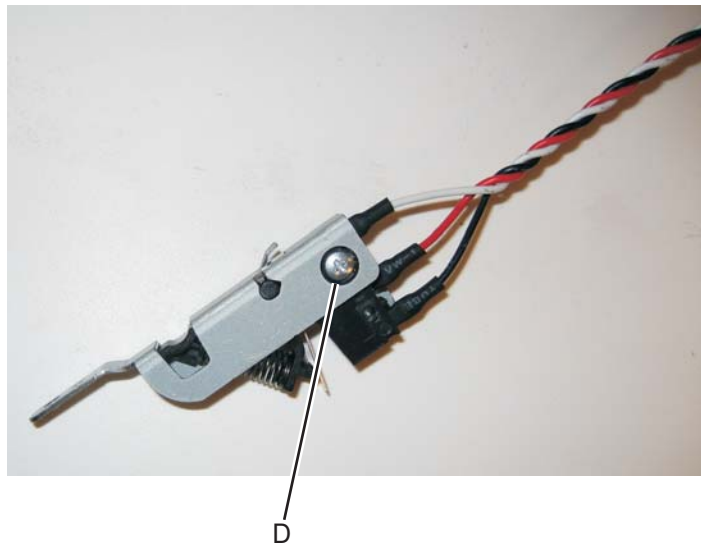

24 V interlock switch removal

See for the part number.

1. Remove the LVPS. See **“24 V interlock switch”** on page 7-7.
2. Disconnect the connector at JCVR1 (A) at system board.



A

3. Remove the screw (B), and the bracket separates from the 24 V interlock switch.

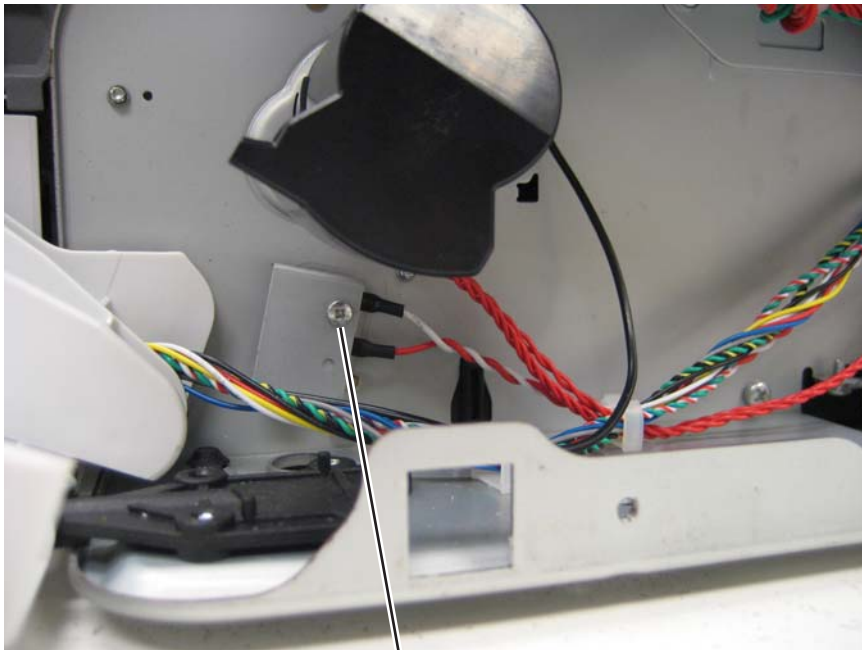

B

Installation notes:

Observe the routing of the 24 V interlock switch cable (A).

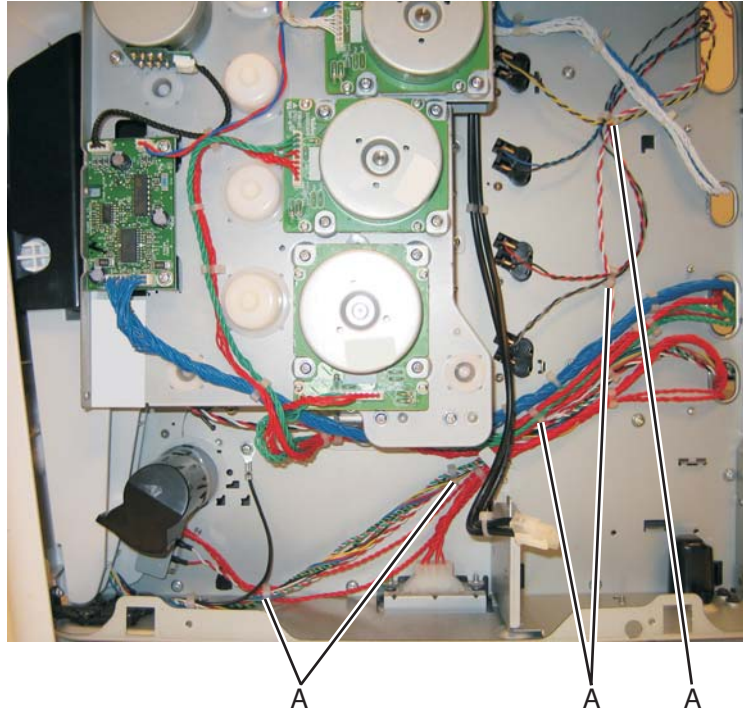

Bin full sensor assembly removal

1. Remove the top cover assembly. See **“Top cover assembly removal”** on page 4-45.
2. Remove the cable from the openings, including the loop through the frame (A).
3. Press up on the tab (B) to remove the flag.

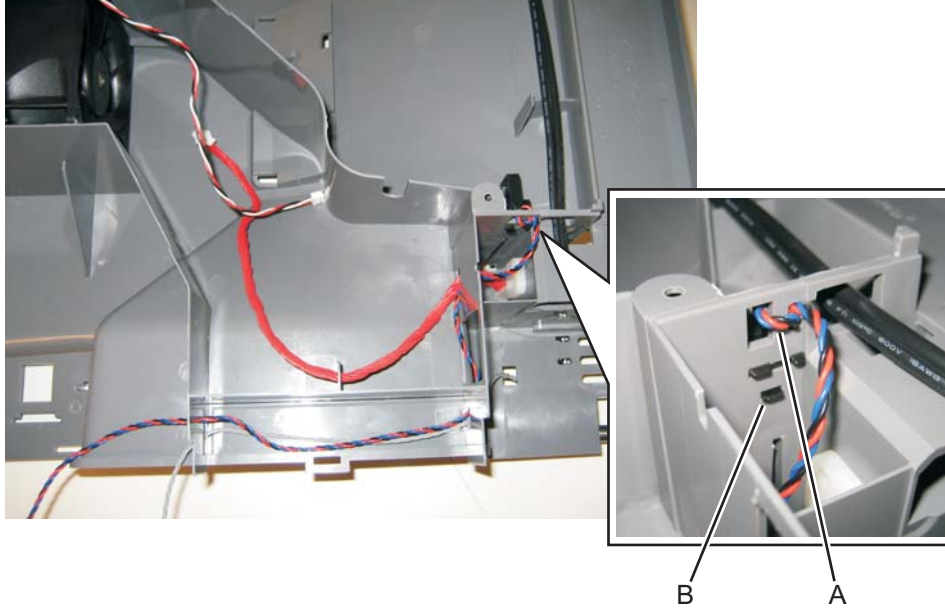

Installation notes:

With the top cover assembly upside down, install the flag with the triangular shape (A) pointing down.

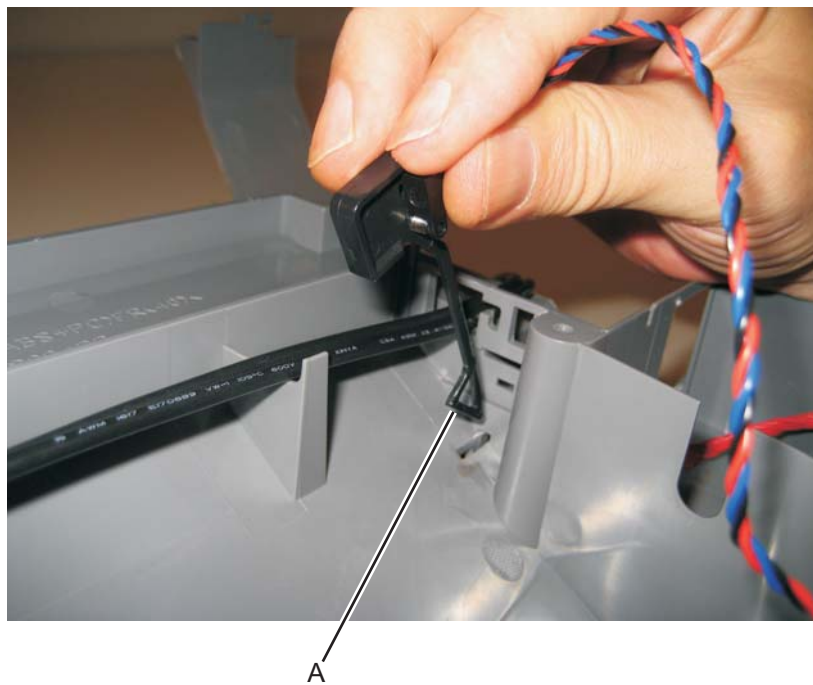

Cartridge cooling fan removal

1. Remove the rear frame cover. See **“Rear frame cover removal”** on page 4-38.
2. Disconnect JBLW1 (A).

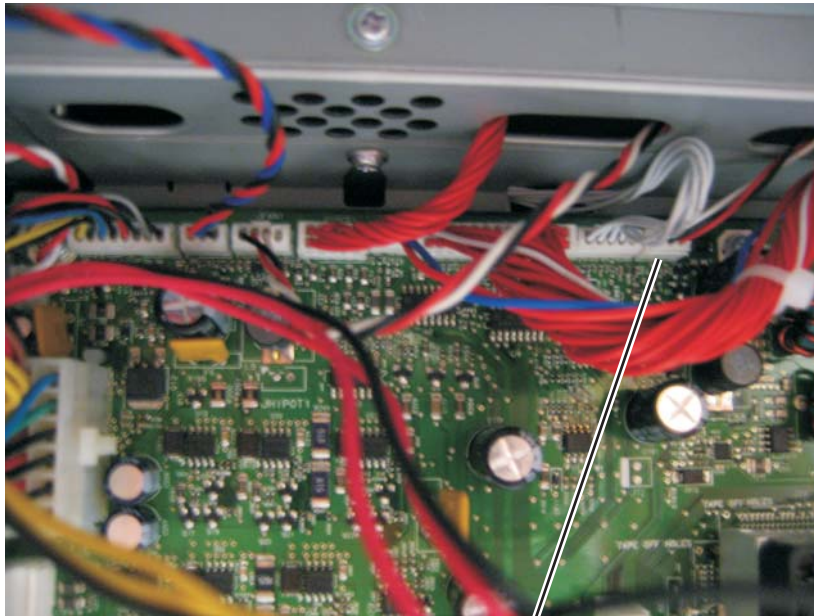

A

3. Open the three clips holding the toroid on the cable, and remove the toroid.
Note: Retain the toroid to reinstall later.

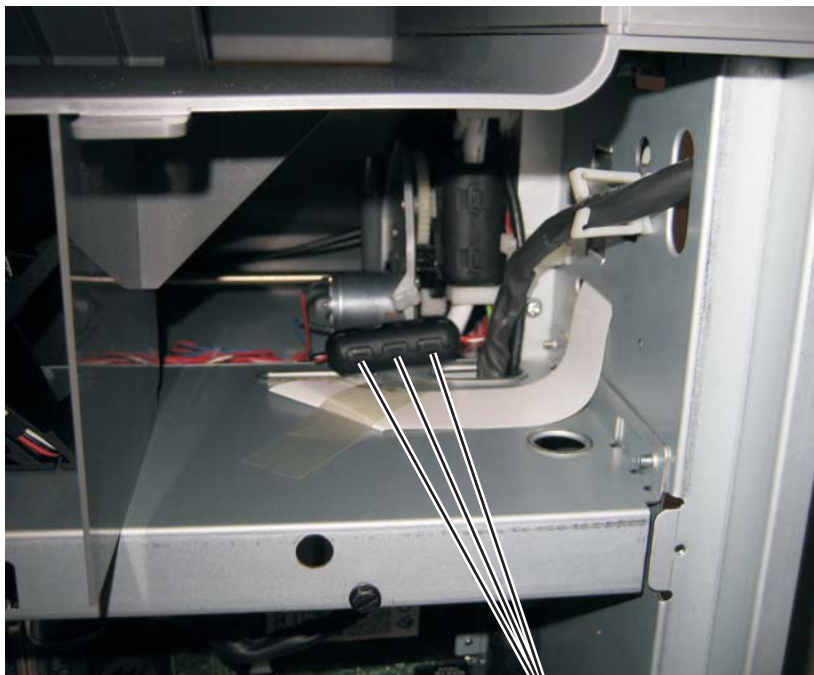

B

4. Remove the right cover. See **“Right cover removal”**.

5. Remove the two screws (C).

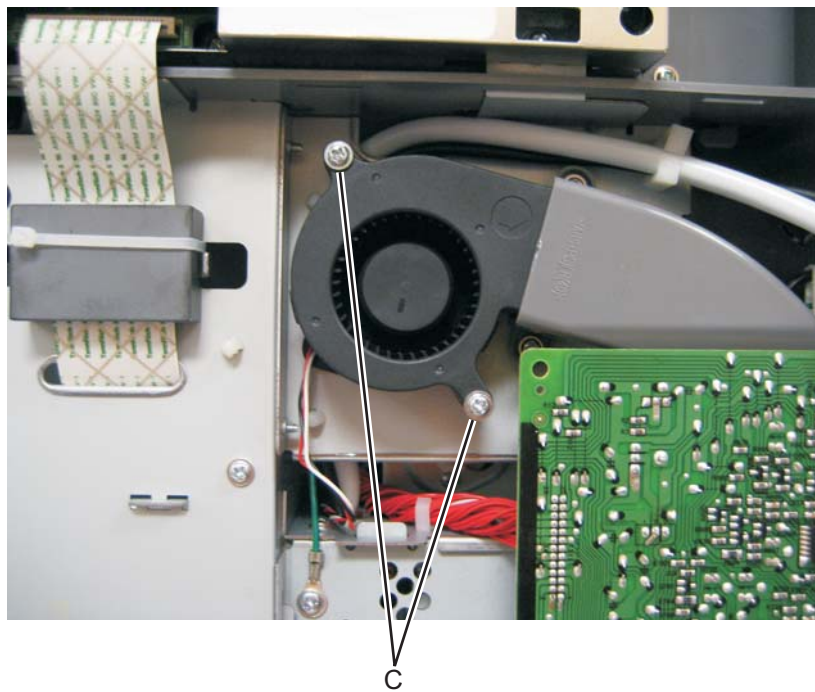

6. Remove the cartridge cooling fan.

Cartridge motor 1/fuser cable removal

1. Remove the LVPS. See **“Low-voltage power supply (LVPS) removal”** on page 4-104.
2. Disconnect the connectors in JCARTP1 (A) and JCARTS1 (B) on the system board.

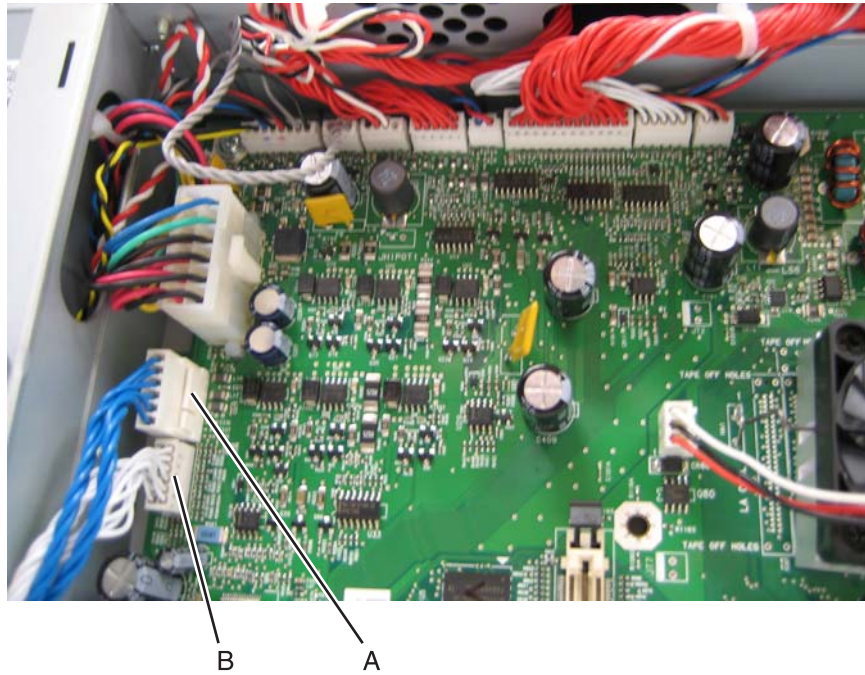

3. Disconnect the connectors from the cartridge motor 1 (C) and the fuser motor (D).

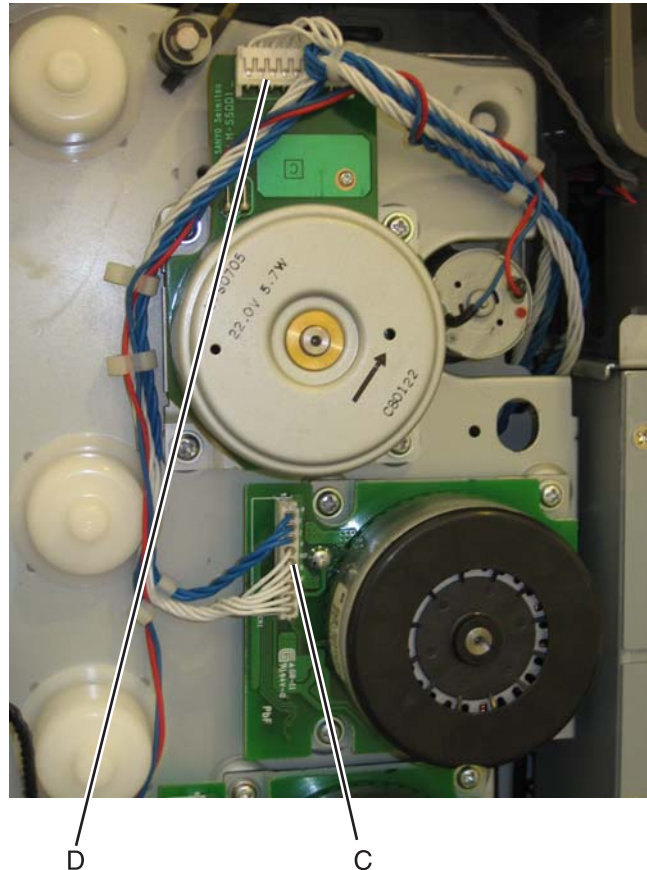

4. Disconnect the camshaft cable connector (E) from the motor card and unwind the two cables.

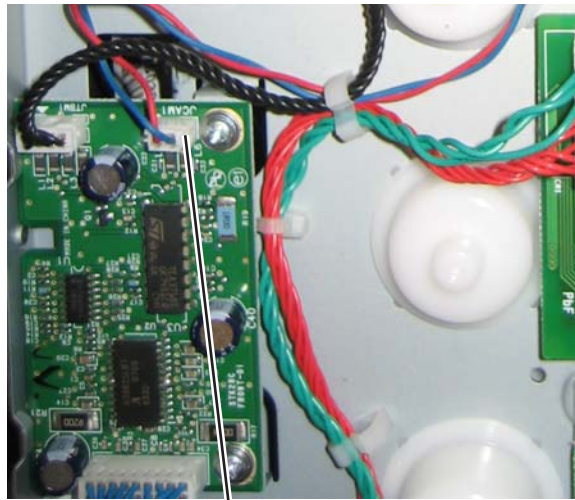

E

5. Remove the cable from the six retainers (F).

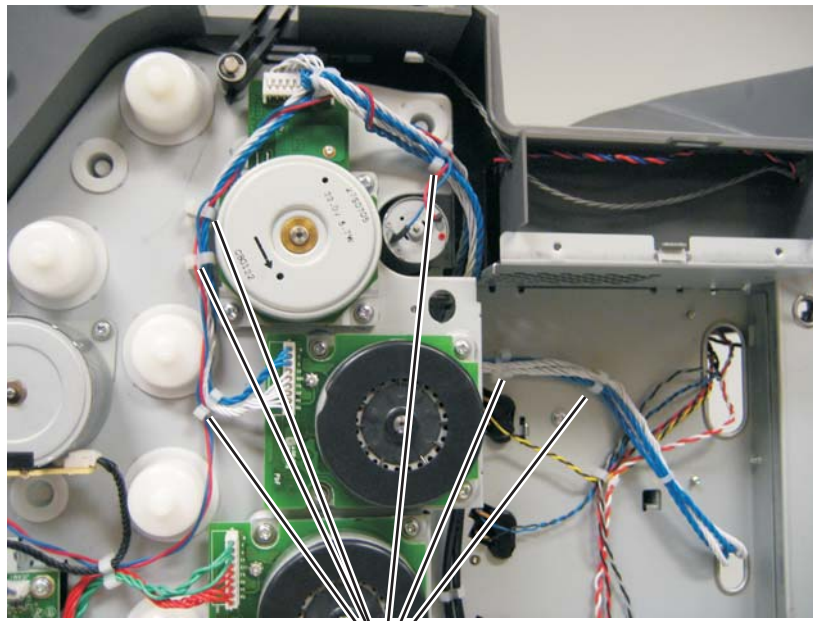

E

Installation notes:

- Make sure you wrap the camshaft cable around the cartridge motor 1/fuser cable, as shown, to prevent the cables from interfering with the motors or the motors damaging the cables.
- Note the routing of the cables and the cable retainers.

Cartridge motor 2/3 cable removal

1. Remove the LVPS. See **“Low-voltage power supply (LVPS) removal”** on page 4-104.
2. Disconnect the connectors in JCARTP2 (A) and JCARTS2 (B) on the system board.

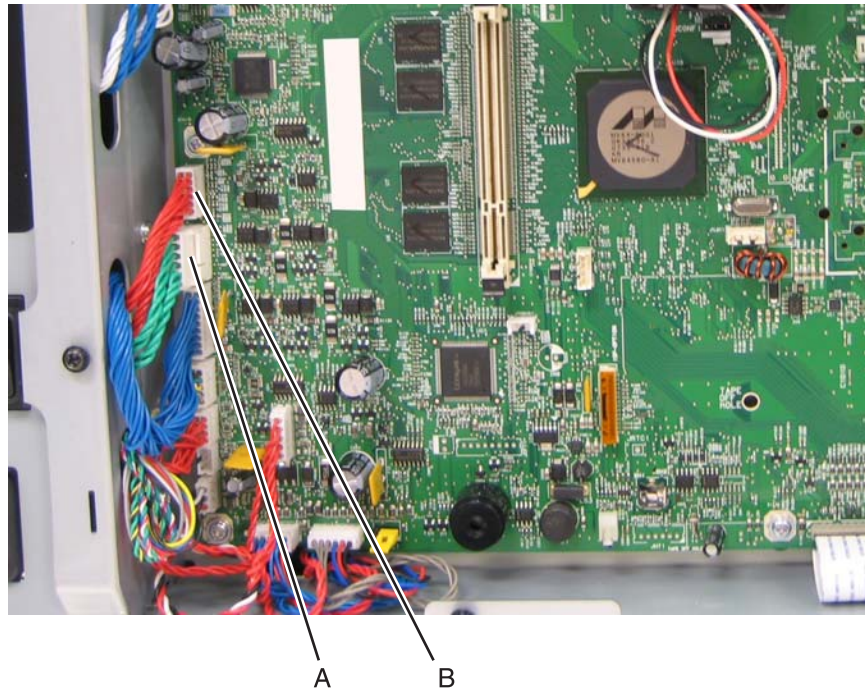

3. Disconnect the connectors from the cartridge motor 2 (C) and cartridge motor 3 (D).

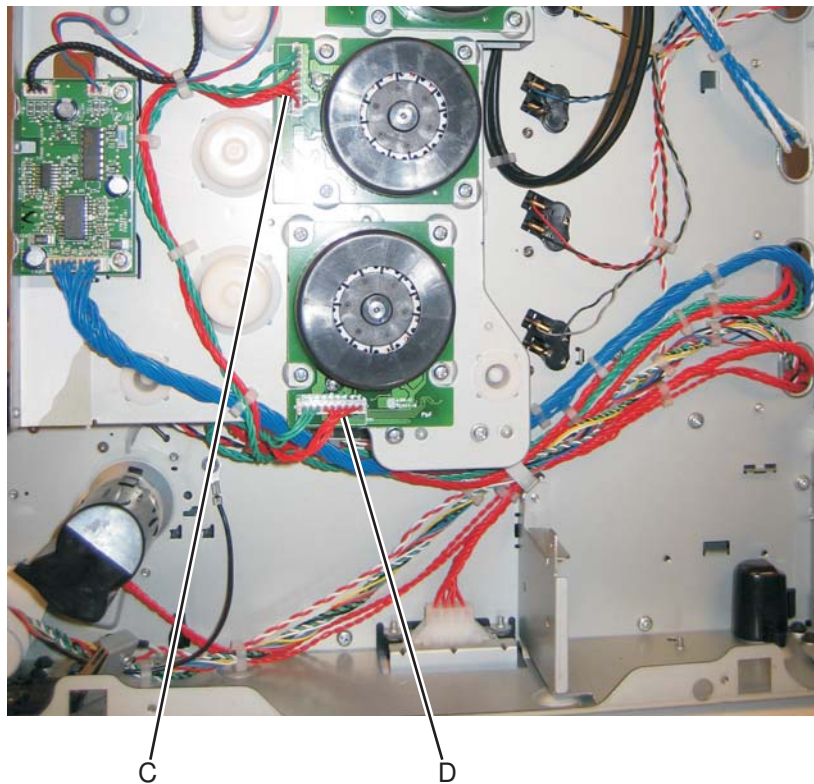

4. Remove the cable from the seven retainers (E).

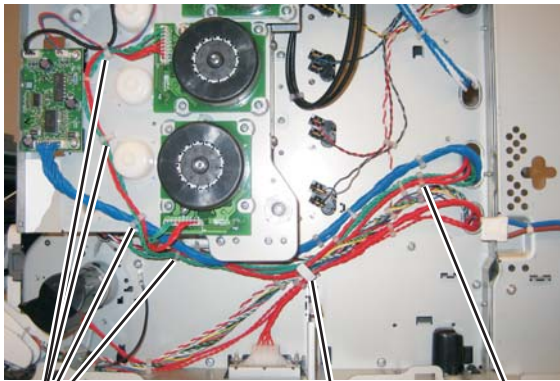

E

E

E

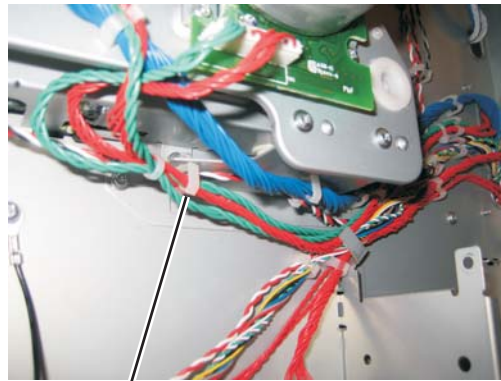

E

Installation notes:

Note the routing of the cables and the cable retainers.

Color on demand assembly removal

1. Remove the print cartridges.
2. Remove the top cover assembly. See **“Top cover assembly removal”** on page 4-45.
3. Disconnect the connector at JBOR1 (A) on the system board.

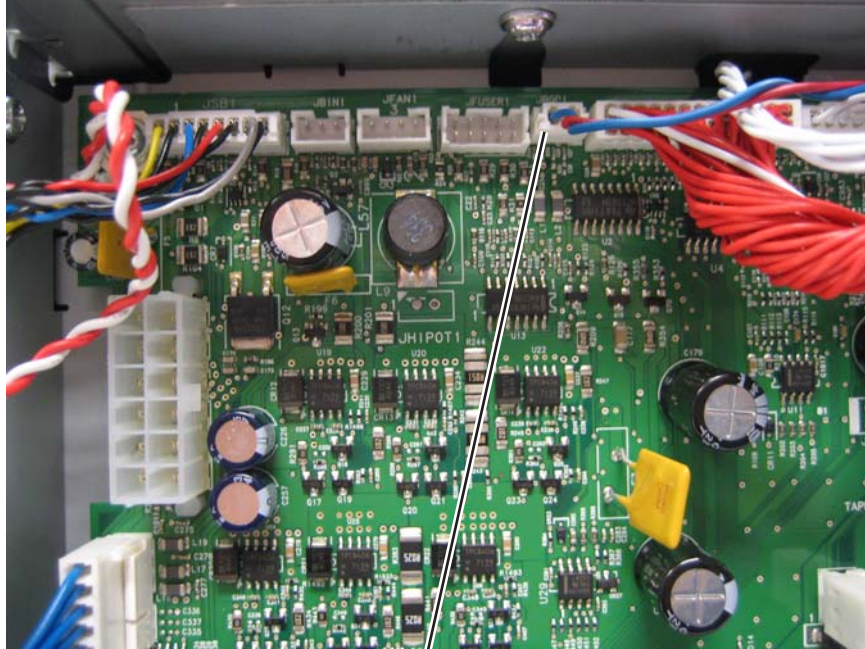

A

4. Remove the five screws (B).

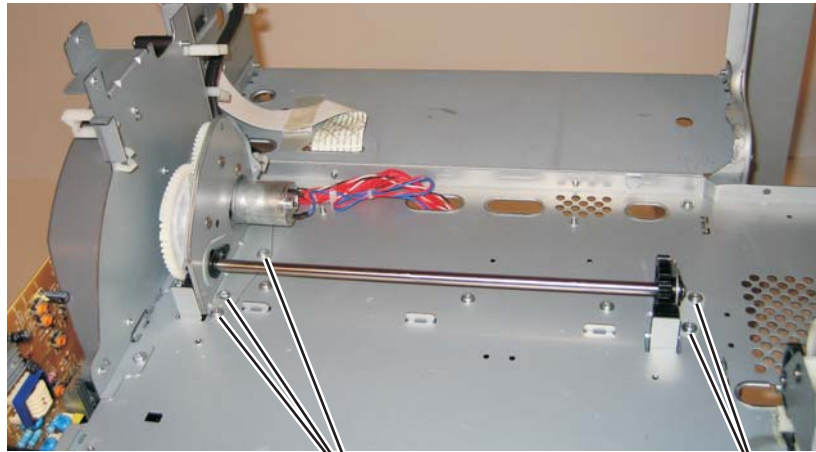

B

B

5. Remove the COD assembly.

Installation notes:

1. Push the actuators (A) all the way down.

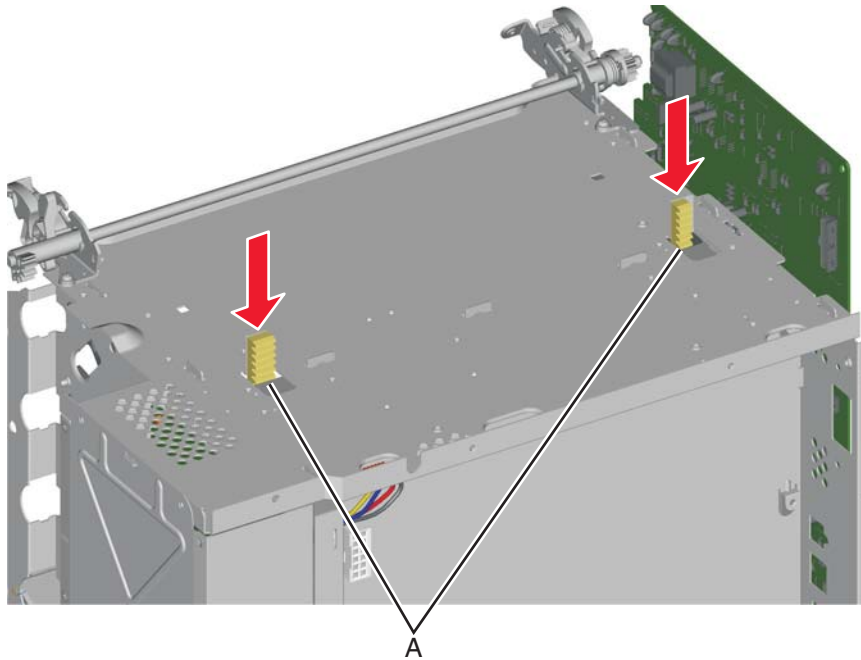

2. Turn the printer around, and verify the actuators are in the correct location by looking inside the front of the printer. The actuators (B) should be visible in the triangular holes in the frame, as shown.

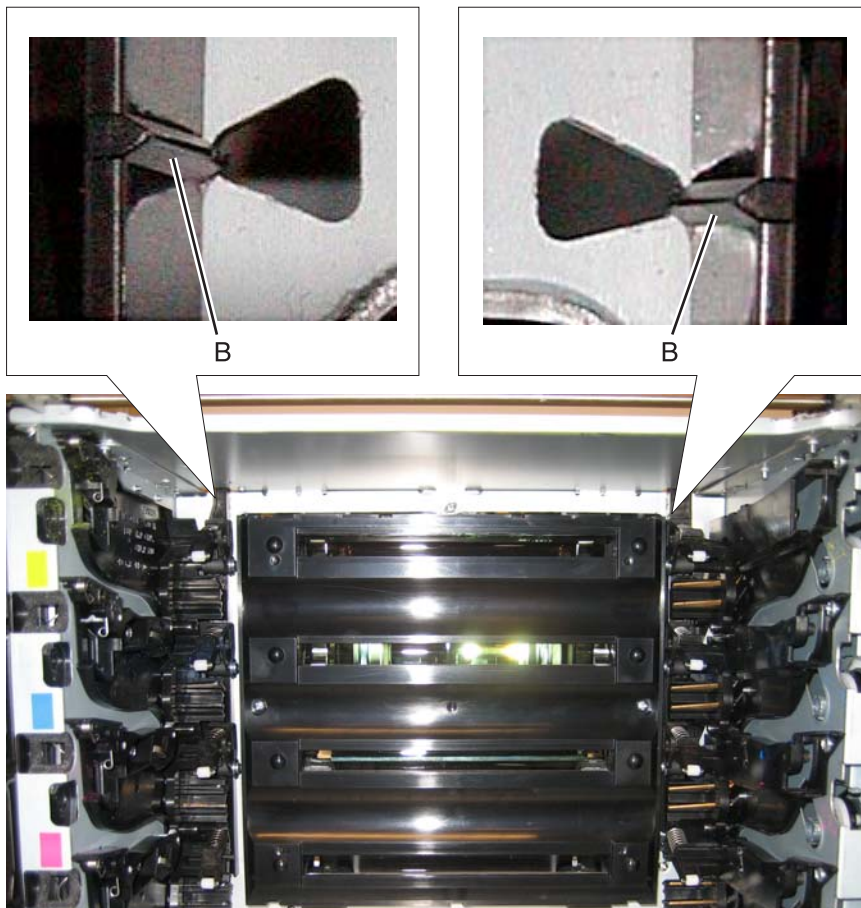

3. Rotate the large COD gear until the stop (C) on the gear is against the housing.

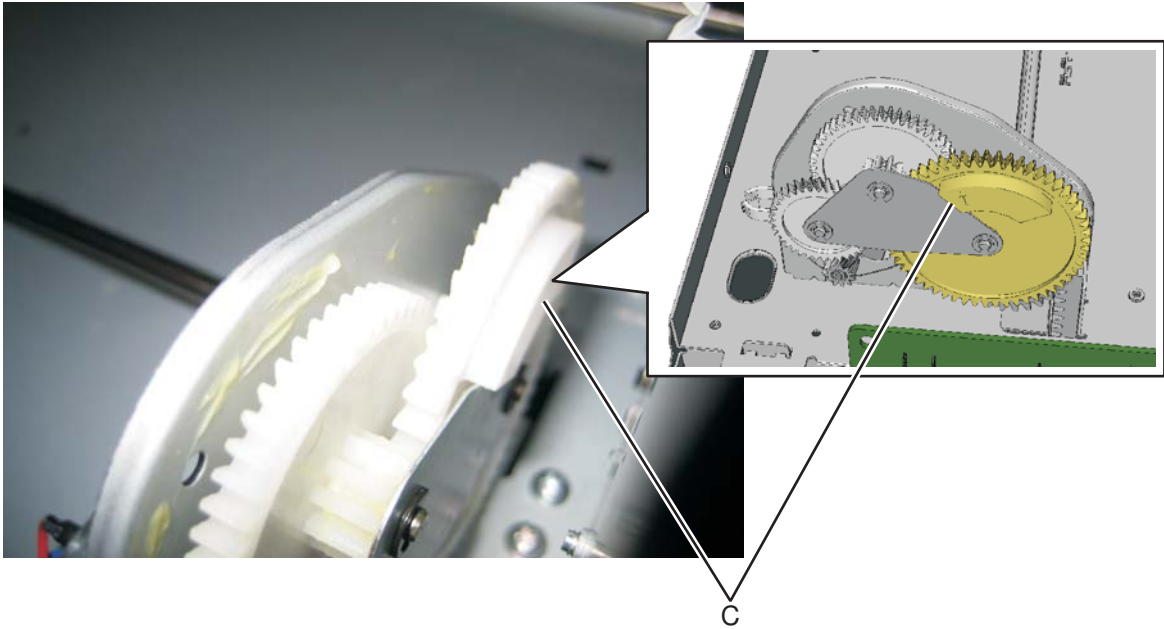

4. Engage the gears on the left side of the COD.

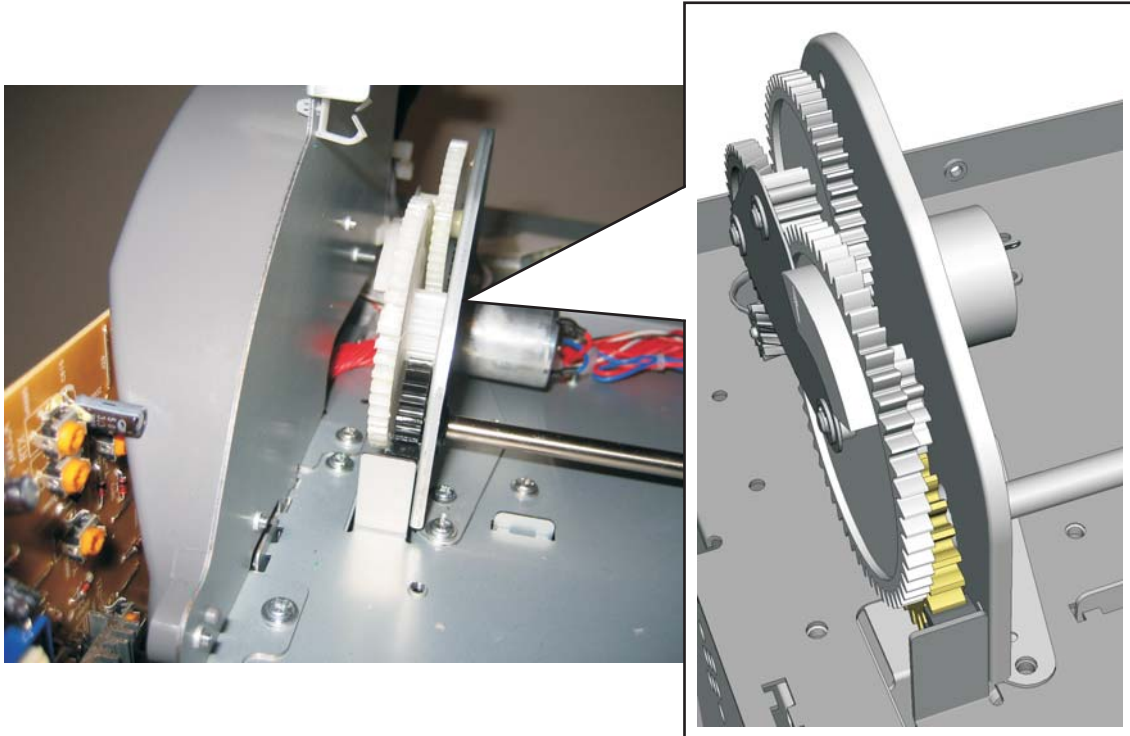

5. Engage the gears (D) on the right side of the COD.
6. Replace the five screws (E).

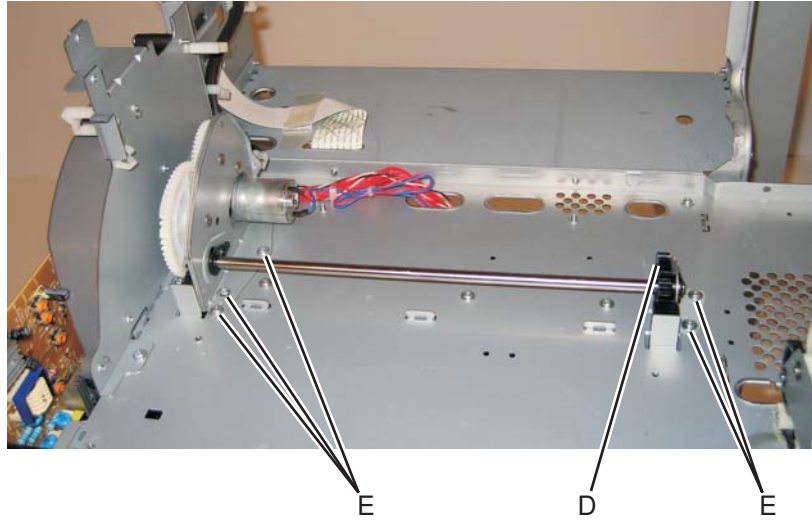

7. Verify the actuators can be seen by looking inside the printer at the triangular holes, as in step 2.
8. Check to make sure you can rotate the large COD gear from stop to stop.

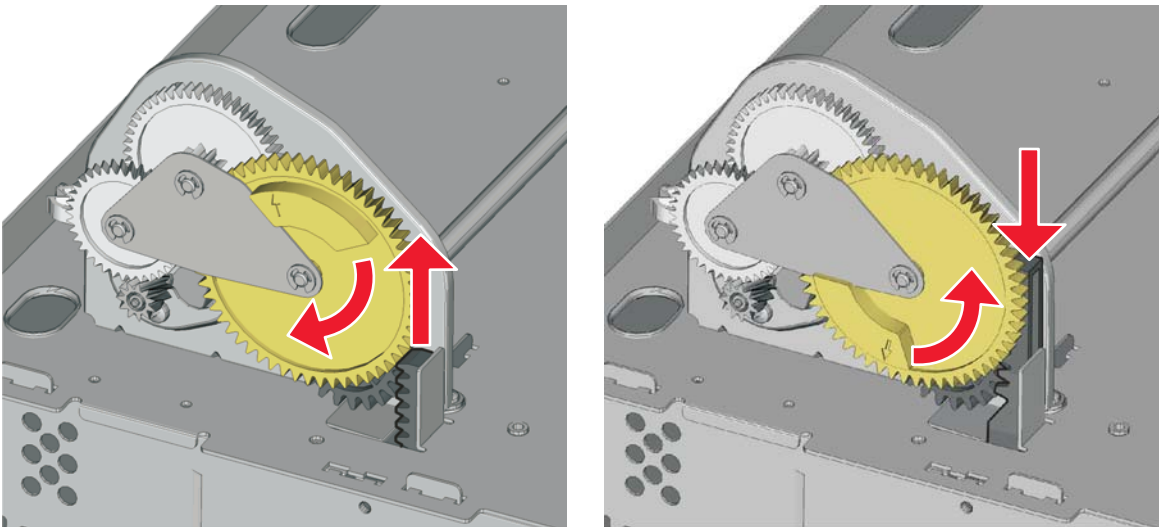

9. Reconnect the cable connector to JBOR1 connector on the system board.
10. Reinstall the top cover assembly, the fuser, and the covers.

Contact springs removal

See for the part number.

1. Remove all the toner cartridges.
2. Remove the screw (A) and the spring cap (B) of the appropriate contact spring.

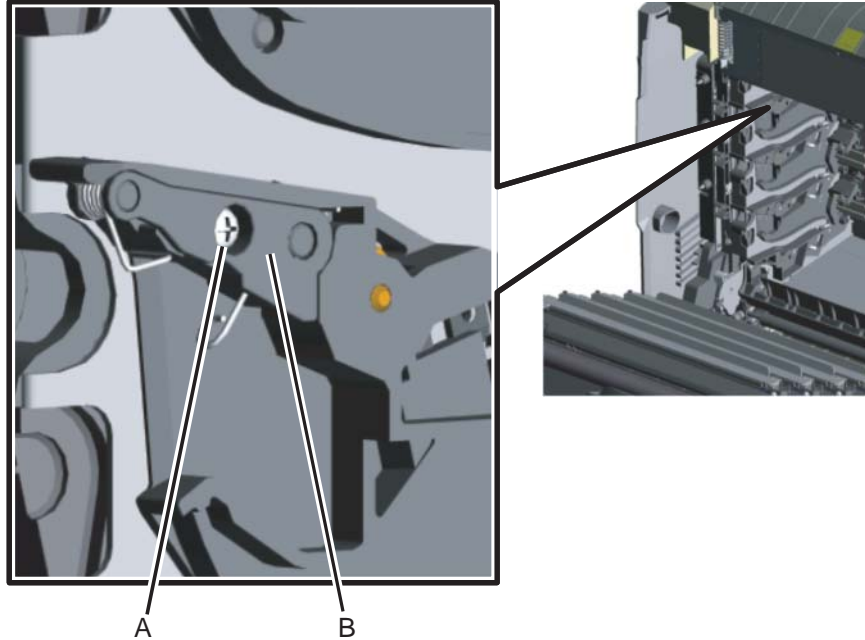

3. Press the lower half (C, D) of the springs and remove the springs.

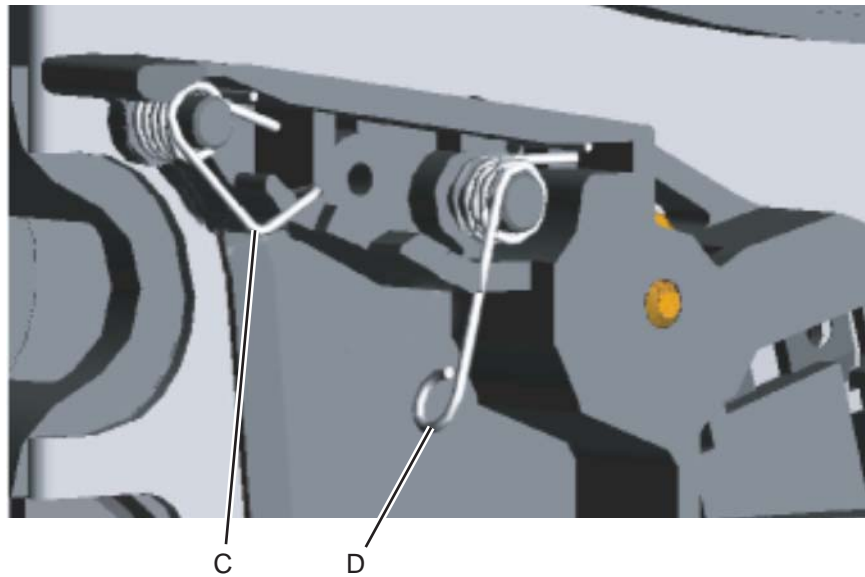

Installation notes: When installing, make sure the top half (E) of the spring is under the straight spring (F). This is typical for both types of springs. Also make sure the bottom half (D,G) of both springs are compressed and locked by the appropriate locking tabs (H, I).

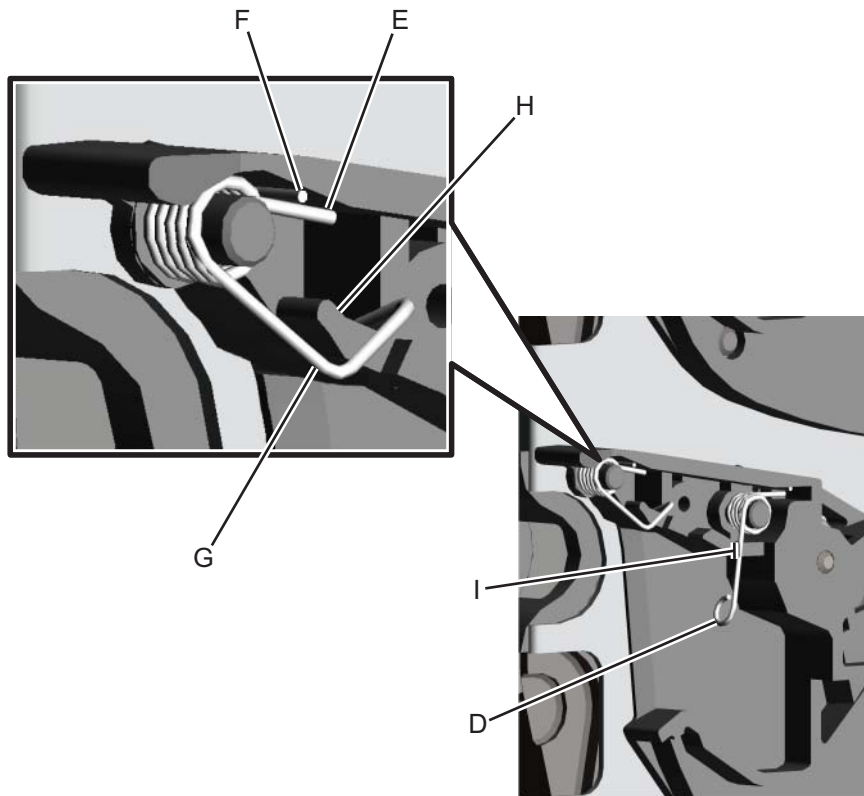

Cooling fan removal

1. Remove the rear frame cover. See **“Rear frame cover removal”** on page 4-38.
2. Remove the rear cover. See **“Rear cover removal”** on page 4-37.
3. Disconnect the cable at the connector JFAN1 (A) on the system board.

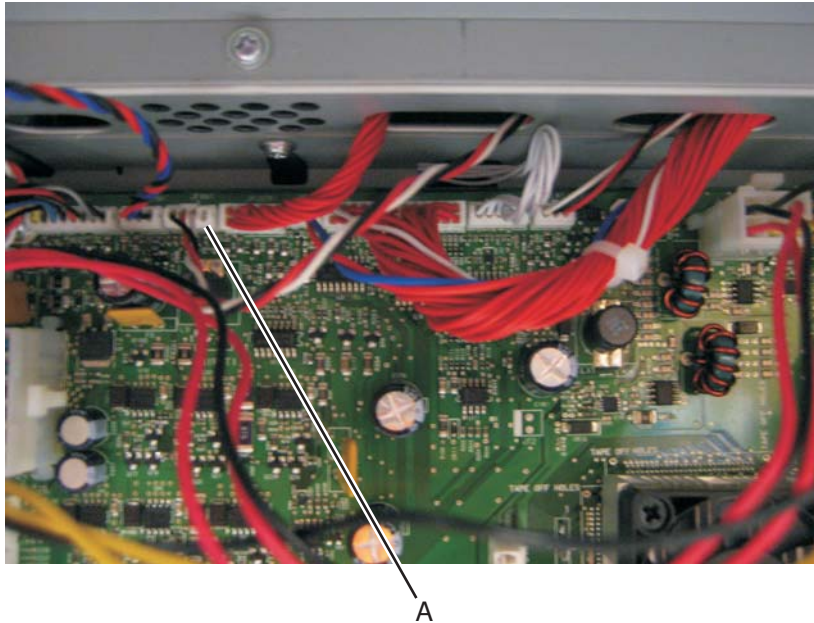

4. Remove the two screws (B).

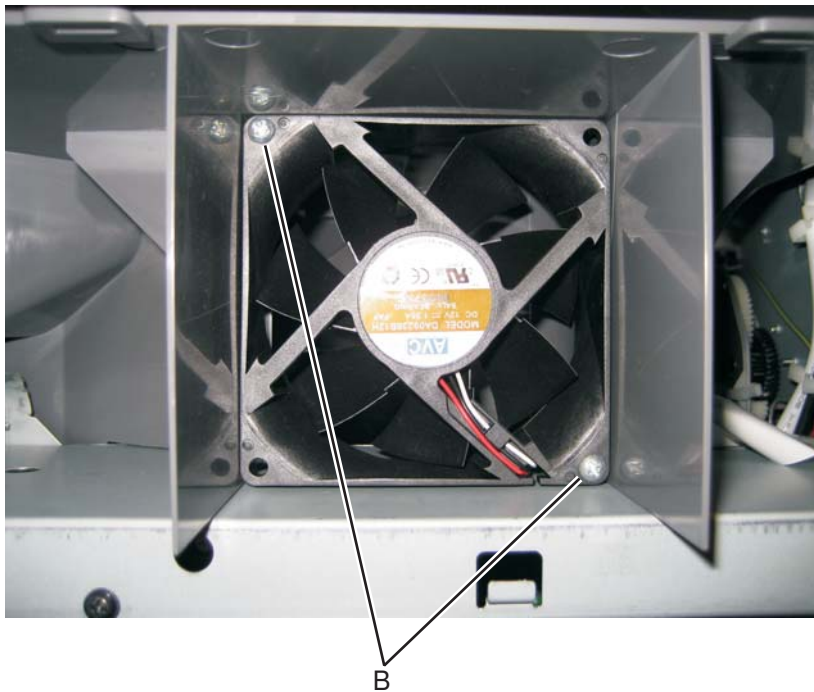

5. Remove the cooling fan.

Cooling fan filter removal

1. Remove the rear cover. See **“Rear cover removal”** on page 4-37.
2. Turn the cover over.
3. Squeeze the right side of the filter, and remove it from the tabs (A).

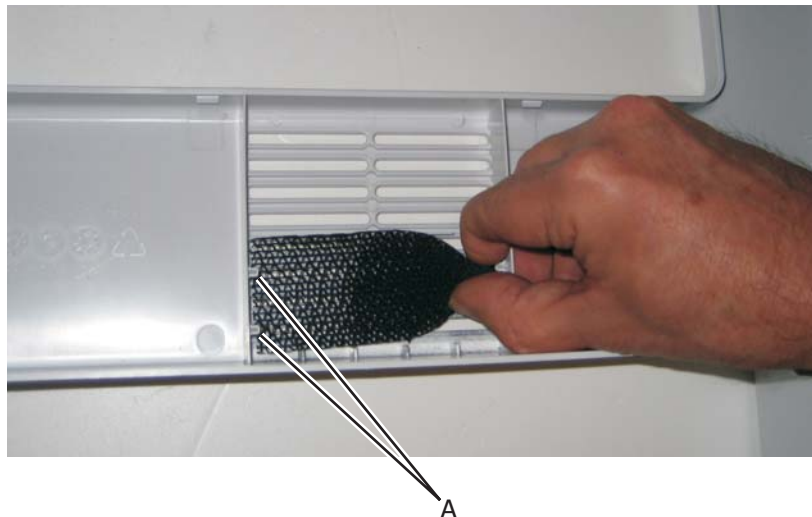

Duplex reference edge guide assembly removal

1. Remove the paper tray.
2. Disconnect the transfer module cable (A).
3. Press the two tabs (B) to release the front access door cover assembly.
4. Press the two tabs (C) on either side of the transfer module, and lift out the transfer module.

Note: Leave the photoconductor units on the transport belt when removing.

Warning: To avoid damaging the photoconductor drum, hold the photoconductor units by their handle and place the photoconductor units on a clean surface. Never expose the photoconductor units to light for a prolonged period of time. See **“Handling the photoconductor unit”** on page 4-2 for additional information.

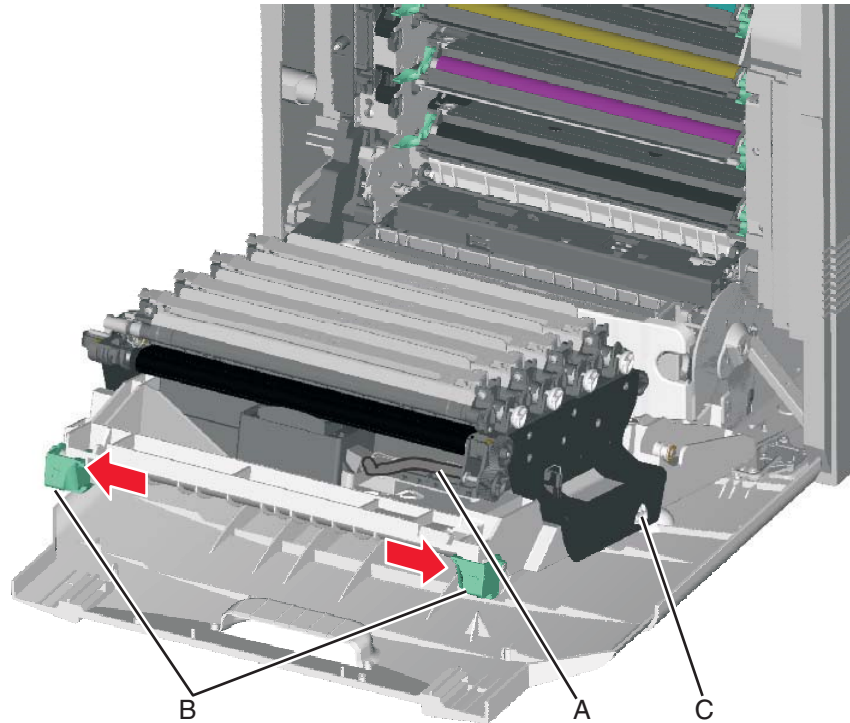

5. Looking down at the keyed end of the restraint (D), twist the end clockwise, slide the restraint upward through the slit (E), and slip the end of the restraint through the keyed hole (F). Repeat for the other side.

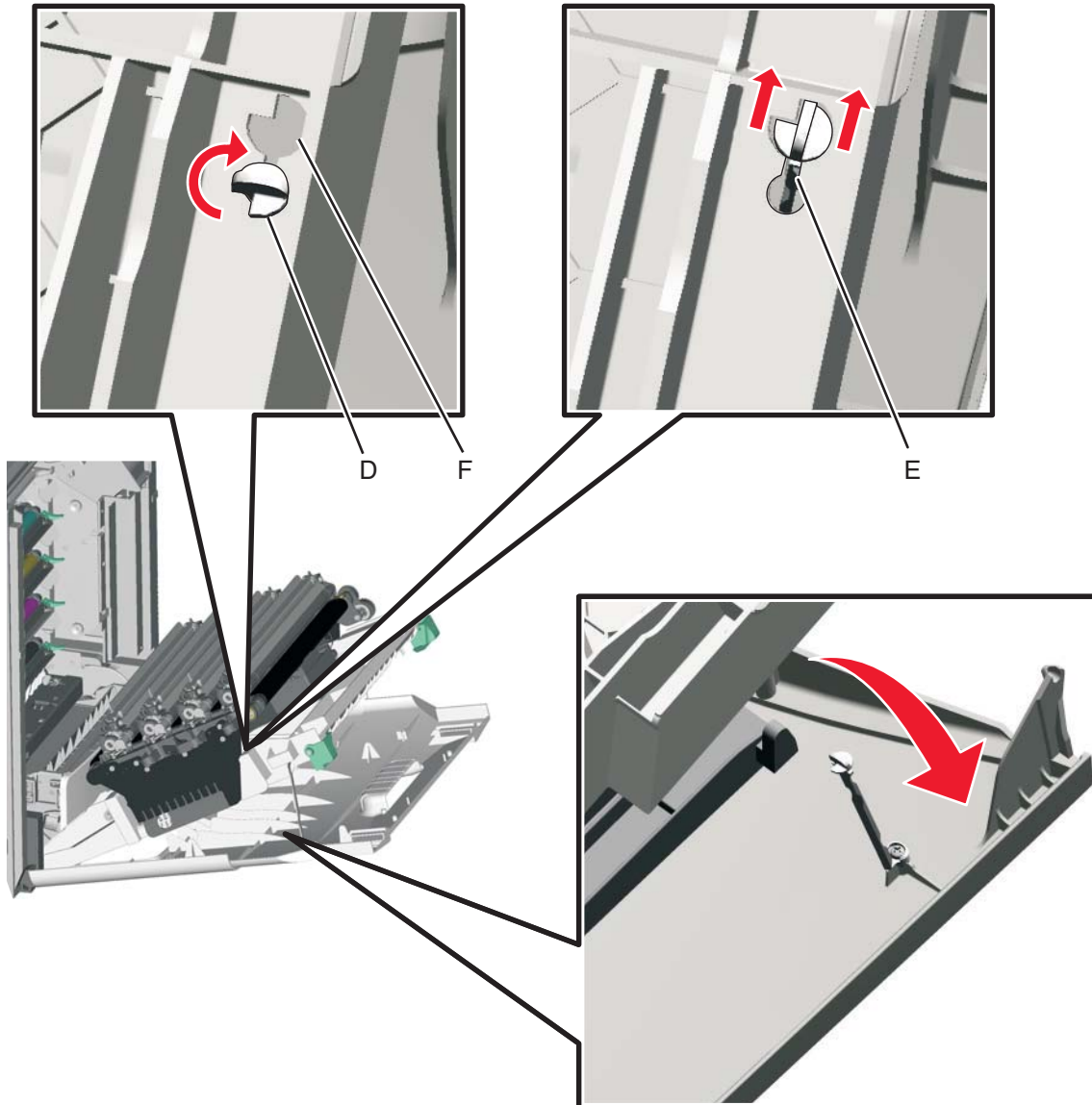

6. Close the front access door assembly.

7. Remove the two screws (G).

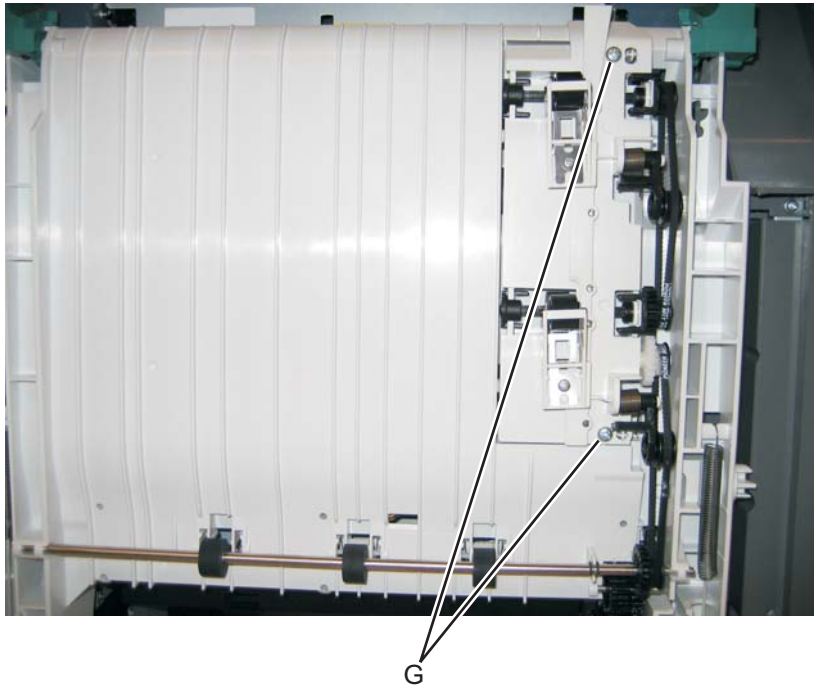

8. Remove the duplex reference edge guide assembly.

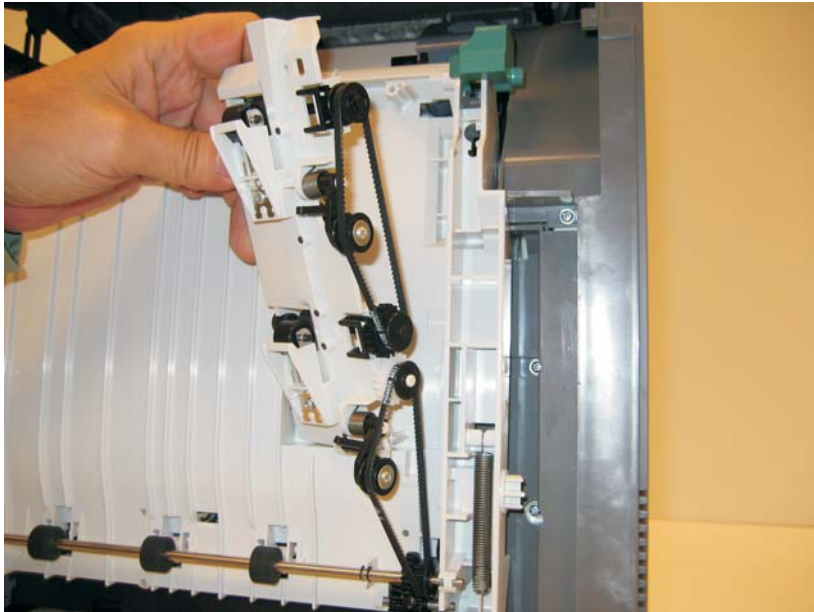

Electrophotographic (EP) drive assembly removal

See for the part number.

1. Remove the paper tray.
2. Disconnect the transfer module cable (A).
3. Press the two tabs (B) to release the front access door cover assembly.
4. Press the two tabs (C) on either side of the transfer module, and lift out the transfer module.

Note: Leave the photoconductor units on the transport belt when removing.

Warning: To avoid damaging the photoconductor drum, hold the photoconductor units by their handle and place the photoconductor units on a clean surface. Never expose the photoconductor units to light for a prolonged period of time. See **“Handling the photoconductor unit” on page 4-2** for additional information.

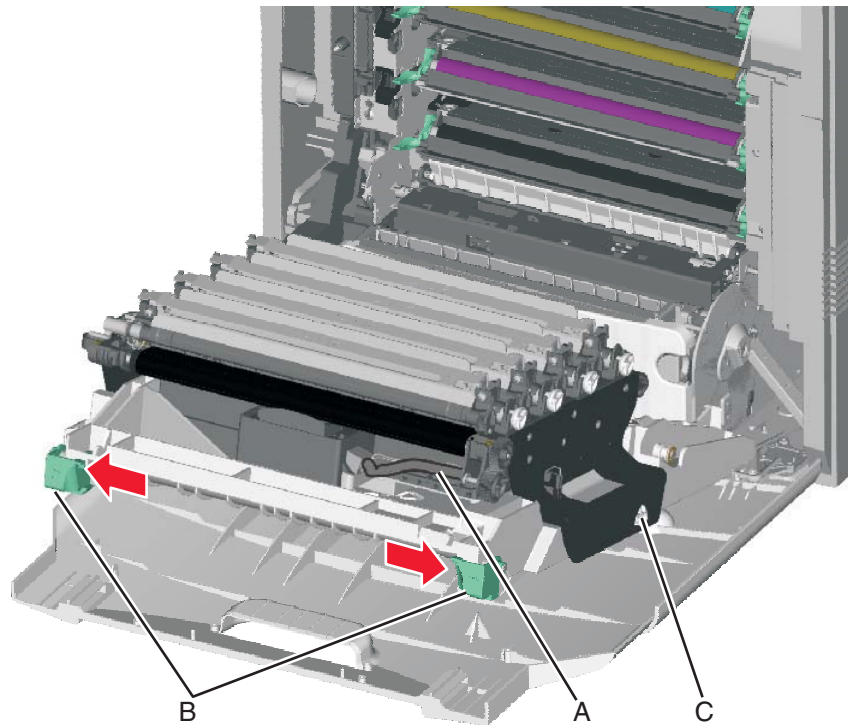

5. Remove the cartridges.
6. Remove the low-voltage power supply (LVPS). See **“Low-voltage power supply (LVPS) removal” on page 4-104**.

7. Disconnect the cartridge 1/fuser motor cable (two connectors) (D), and remove the cables from the cable retainers (E).

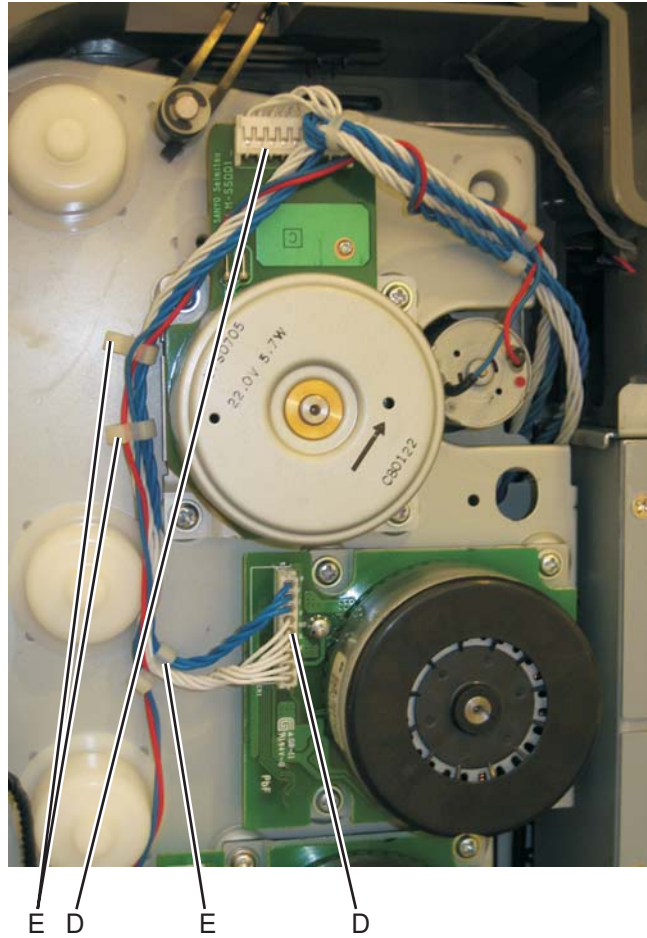

8. Disconnect the camshaft/transport cable connector (F), and remove the cable from the cable clamp (G).

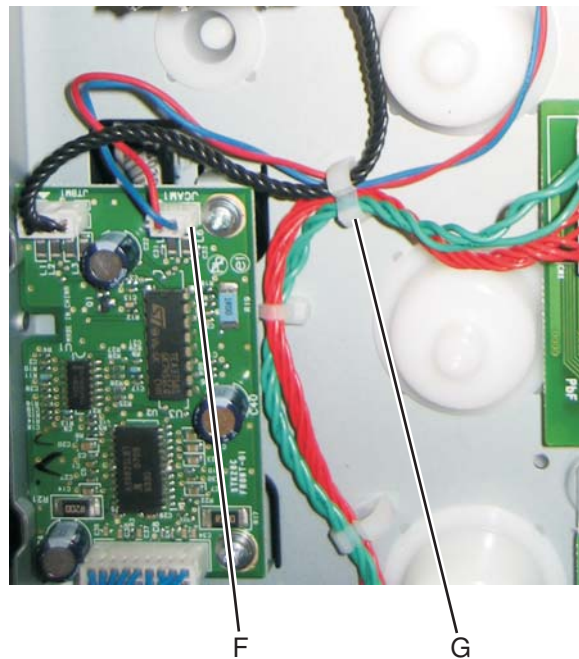

9. Unwind the camshaft/transport cable and the cartridge 1/fuser cables (H).

Note: Be sure to rewind the camshaft/transport cable around the other cables with about four twists to keep them from interfering with or being damaged by the motors.



H

10. Disconnect the cartridge 2/cartridge 3 motor cable (two connectors) (J), and remove the cable from the cable clamps (K).

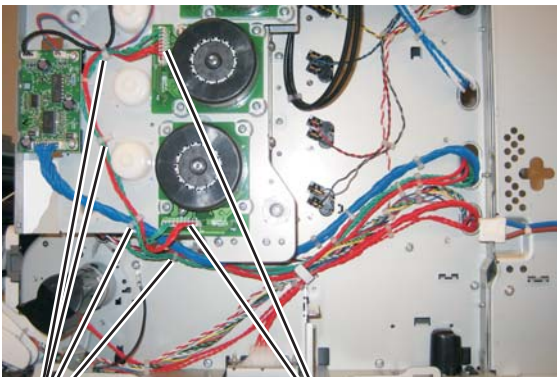

K

J

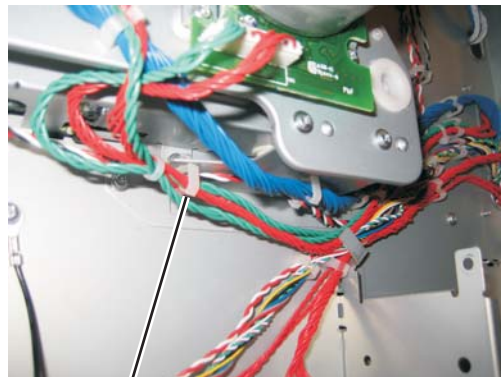

K

11. Disconnect the motor drive cable connector (L), and remove the cable from the cable clamps (M)

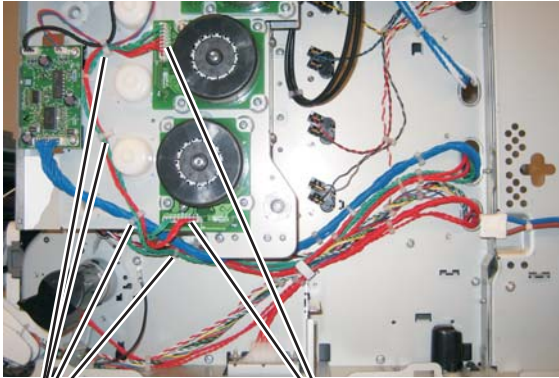

K J

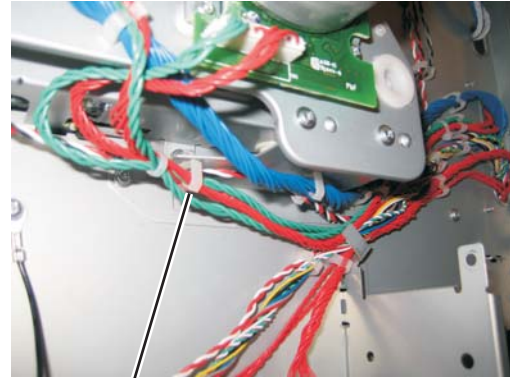

K

12. Remove the three screws (N) on the front.

13. Remove the two screws (O) on the inside.

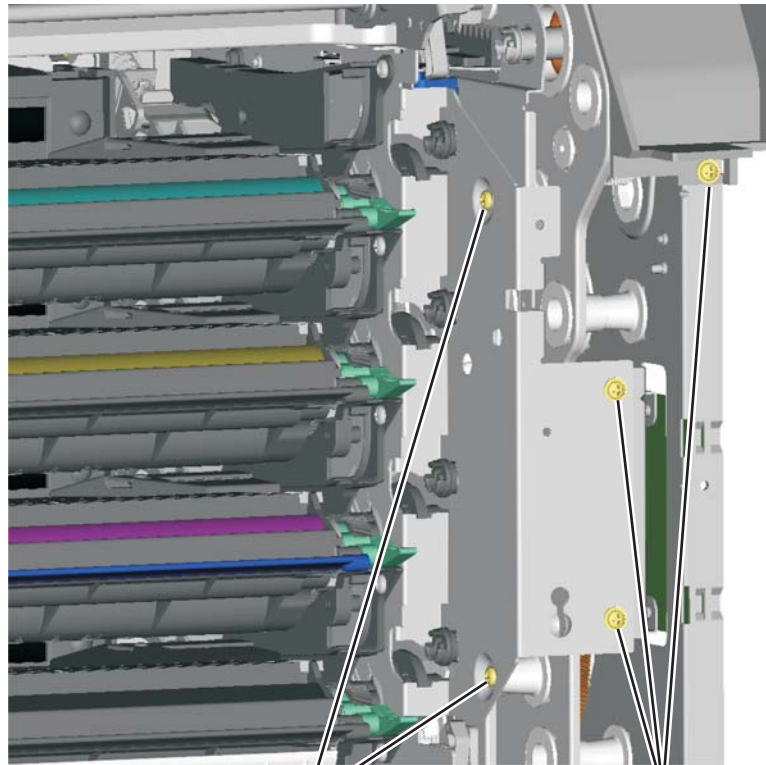

N

O

14. Remove the seven screws (P), securing the EP drive.

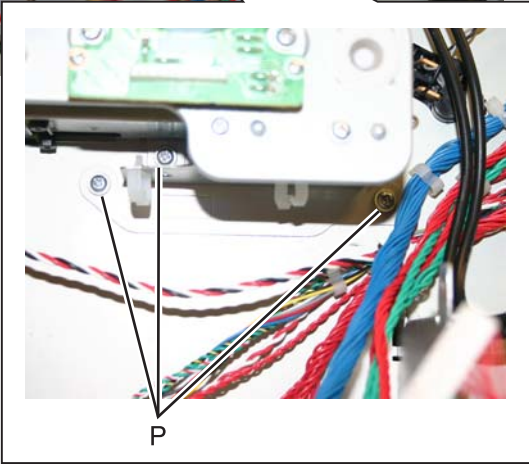
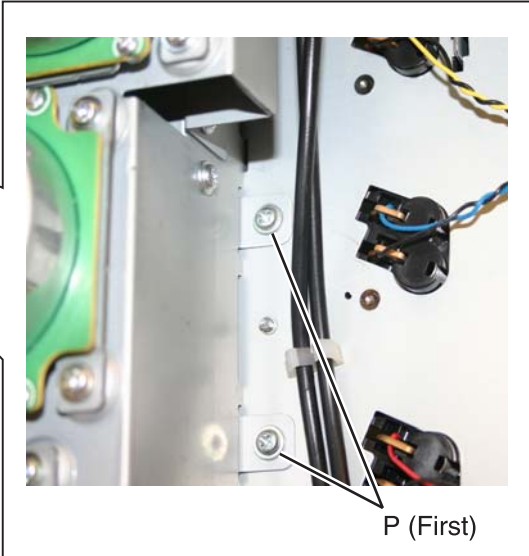
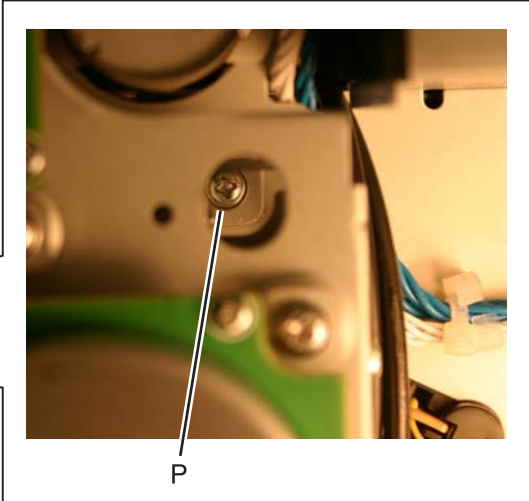
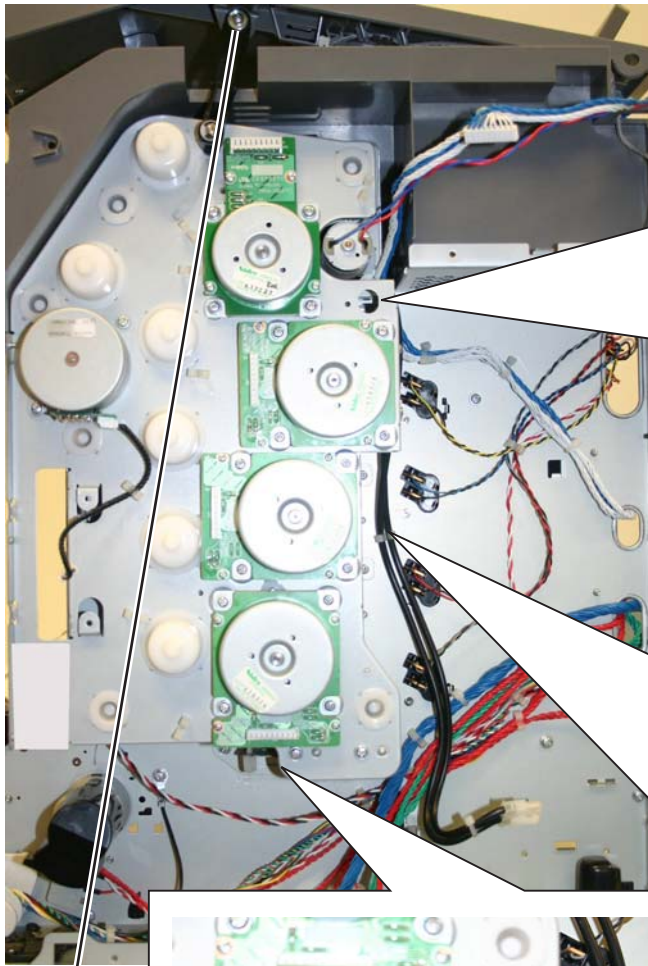

15. Remove the 5 V interlock switch cable from the restraint (R) on the backside of the EP drive.

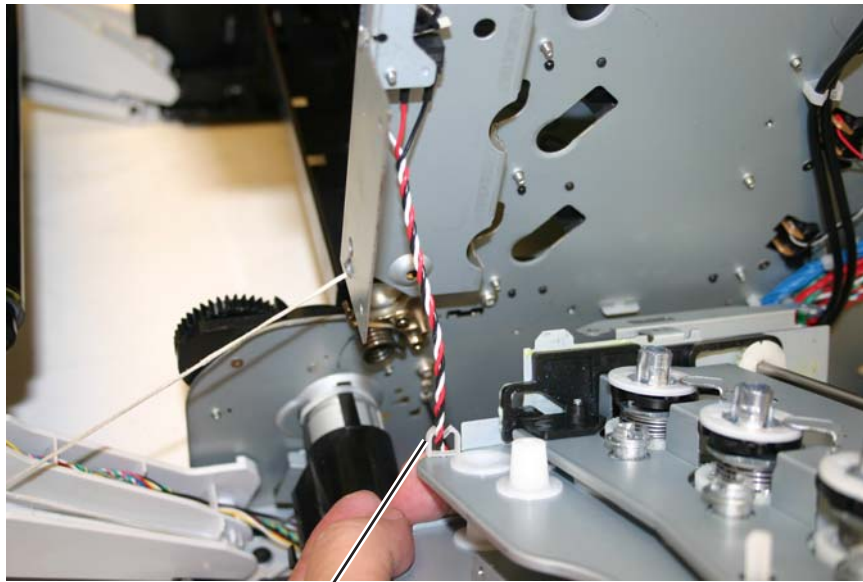

R

16. Remove the EP drive.

Installation notes:

The EP drive assembly for the single-function printers and the multiple-function printers (MFP) are the same, except for the fuser retract link. The package comes with the EP drive assembly with the single-function printer link installed. To set up the EP drive for the multiple-function printer (MFP), exchange the links.

To change the fuser retract link:

1. Remove the E-clip (A) and the follower cam.
2. Remove the fuser retract link (B), and discard.

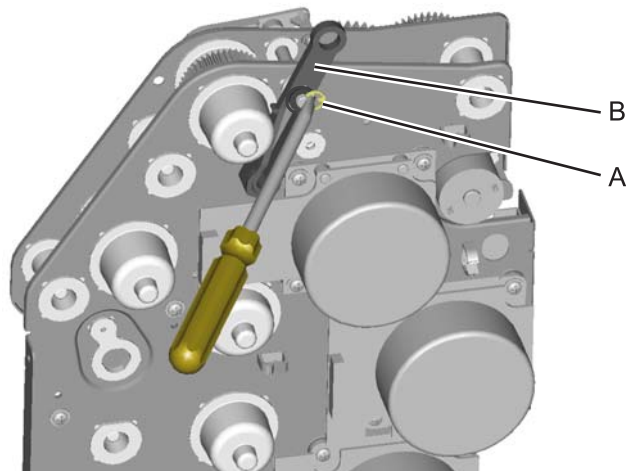

3. Install the new fuser retract link (C), the follower cam (D), and the E-clip (E).

Note: Be sure to orient the follower cam so that the smaller diameter side is against the fuser retract link, and the larger diameter is next to the E-clip.

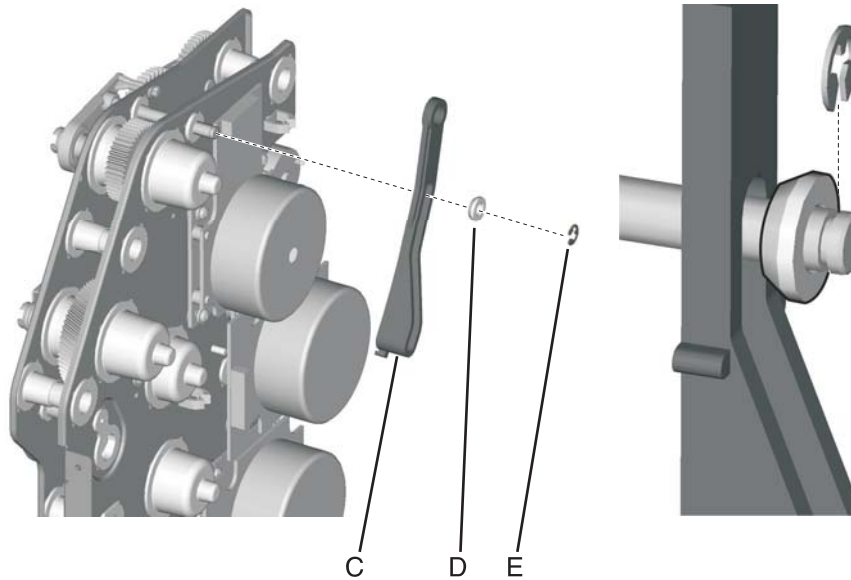

To install the EP drive:

1. Push the actuator rack all the way to the right (A).
2. Pull the link all the way up (B).

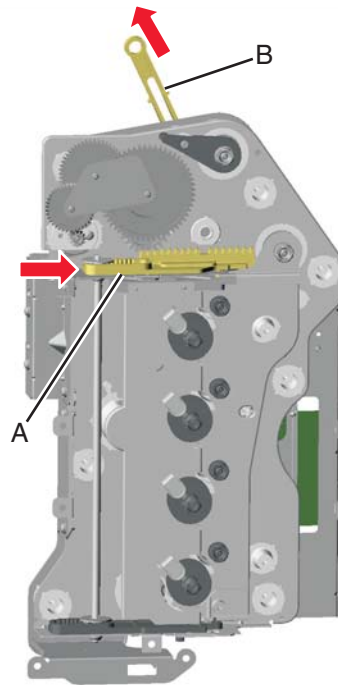

Note: After installing the EP drive assembly, be sure to test the link by moving it up and down. It should move freely and not rub against any motor cables.

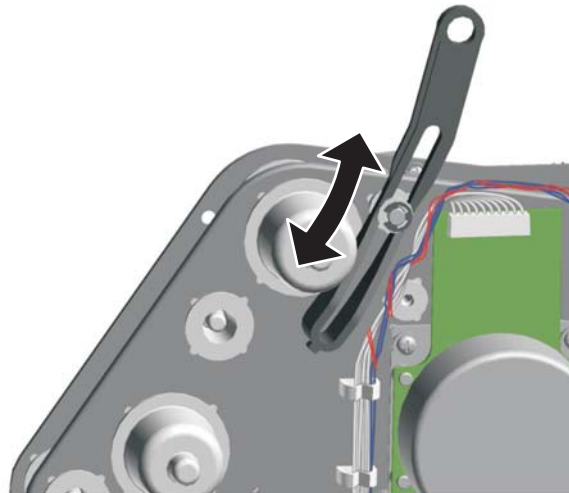

3. Fasten the 5 V interlock cable into the cable retainer (C) on the bottom of the EP drive.

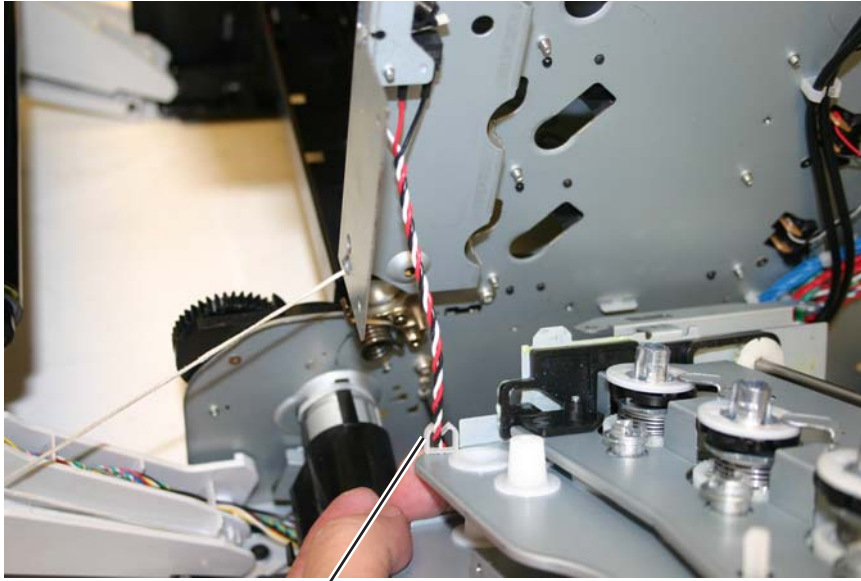

C

4. Align the gear so the first gear tooth (D) of the top cover camshaft meshes with the first two gear teeth (E) after the flat area in the EP drive actuator rack, and then seat the right side of the top cover camshaft into the boss (F) on the EP drive.

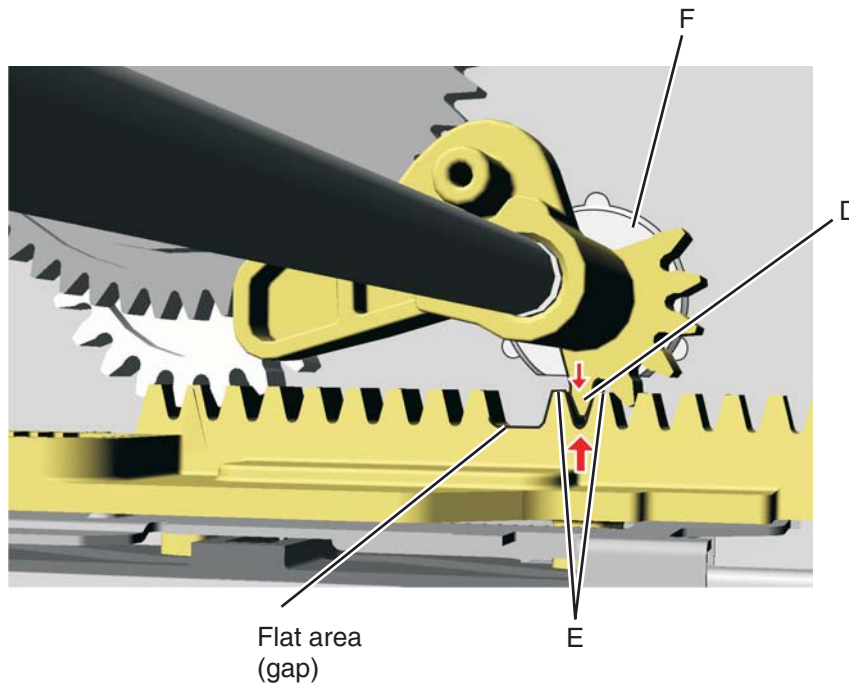
Flat area
(gap)

5. Hold the drive in place while replacing the first of the seven screws, then continue replacing the rest of the screws (G).

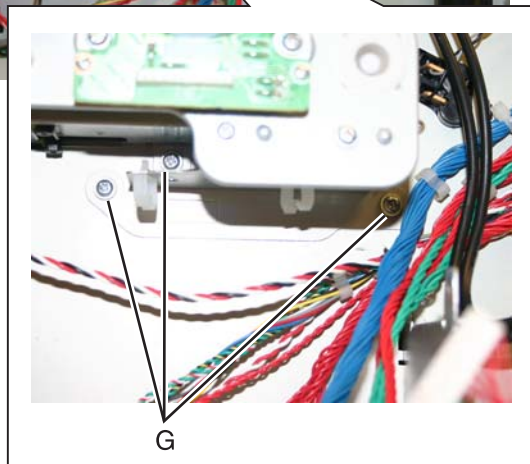
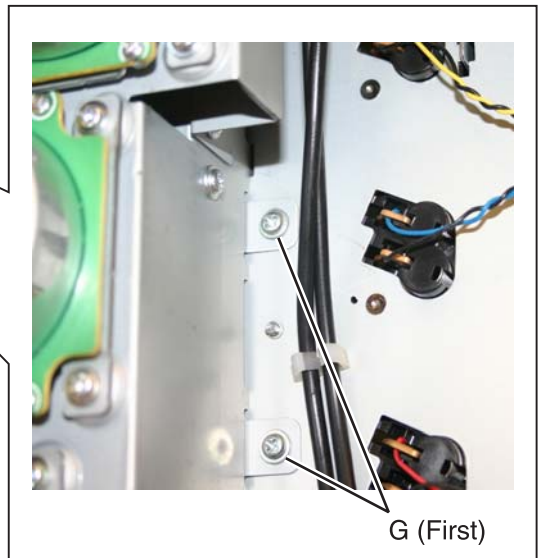
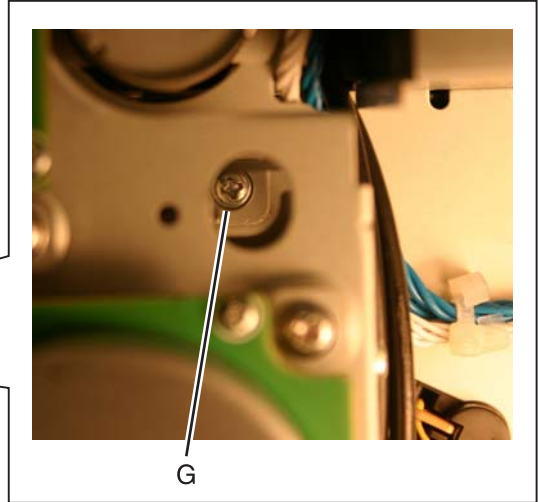
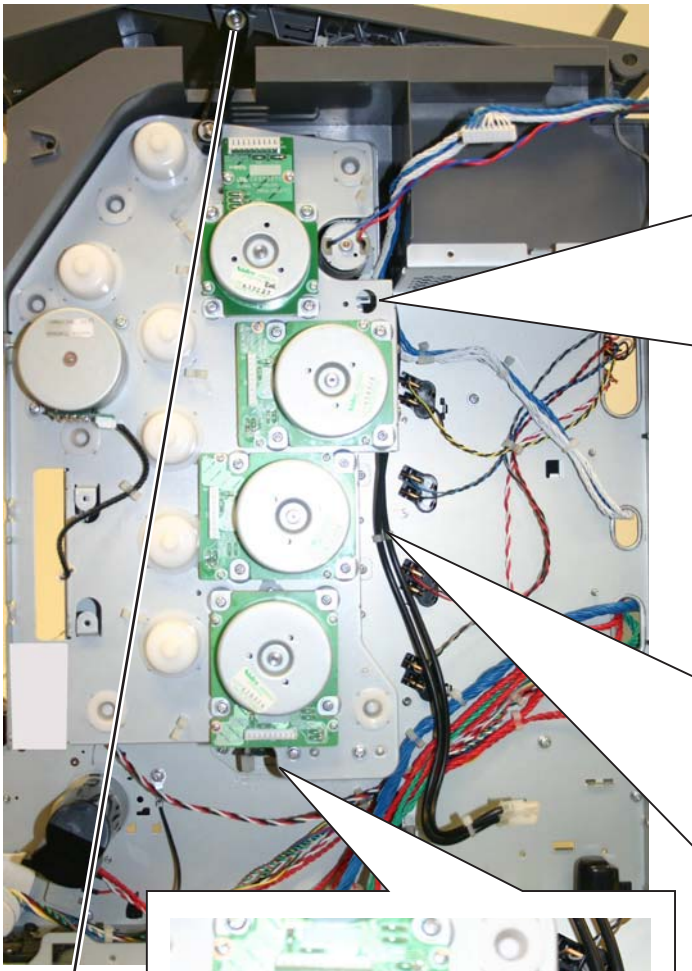

6. Replace the two screws (H) from the inside.
7. Replace the three screws (J) on front.

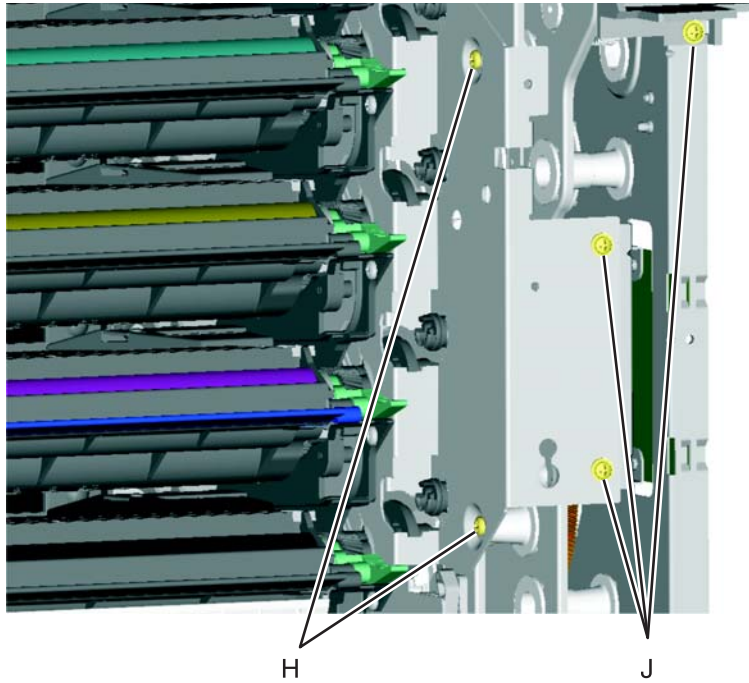

8. Wind the camshaft cable (K) around the cartridge 1/fuser cables about four times to make sure they do not interfere with or are damaged by the fuser motor.
9. Connect the cartridge 1/fuser motor cable (two connectors) (L), and place the cables in the cable retainers (M).

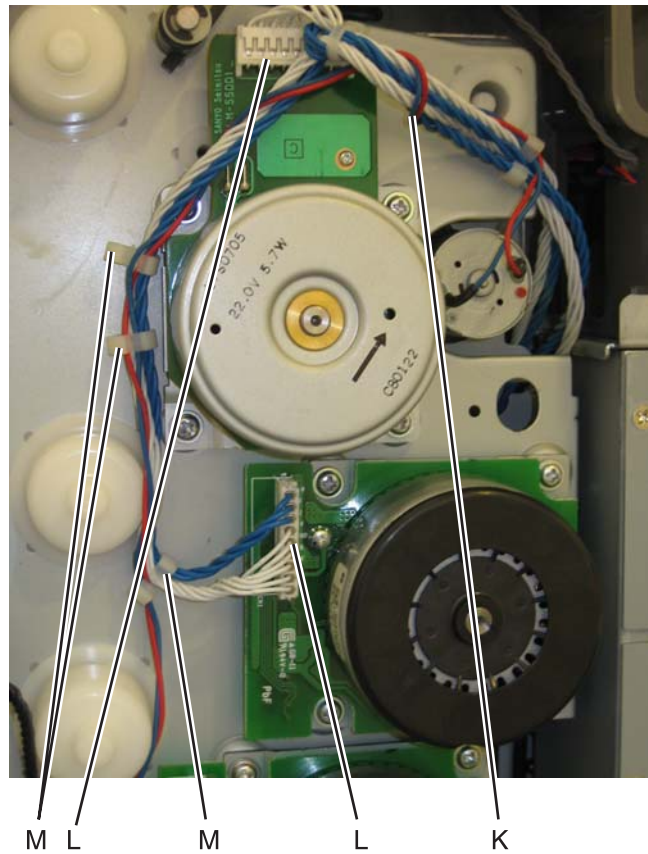

10. Connect the cartridge 2/cartridge 3 motor cable (two connectors) (N), and make sure the cable is in the cable clamps (O).

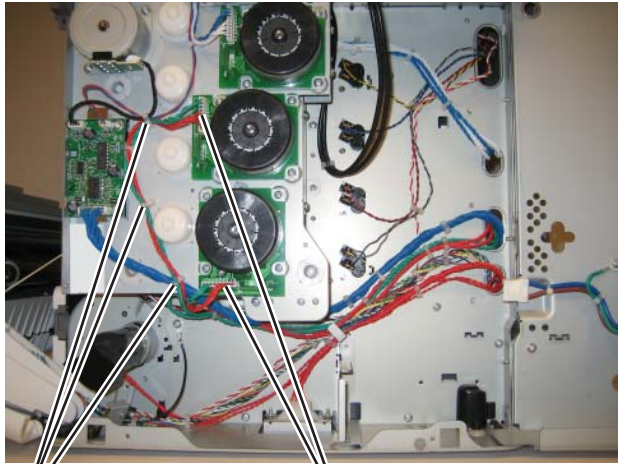

11. Connect the camshaft/transport cable connector (P), and make sure the cable is in the cable clamps (R).

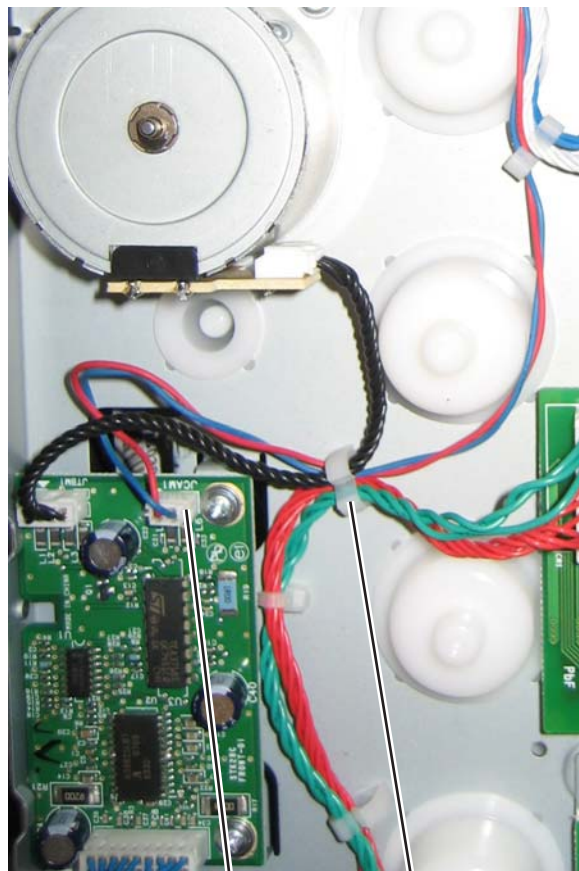

12. Connect the motor drive cable connector (S), and make sure the cable is in the cable clamps (T).

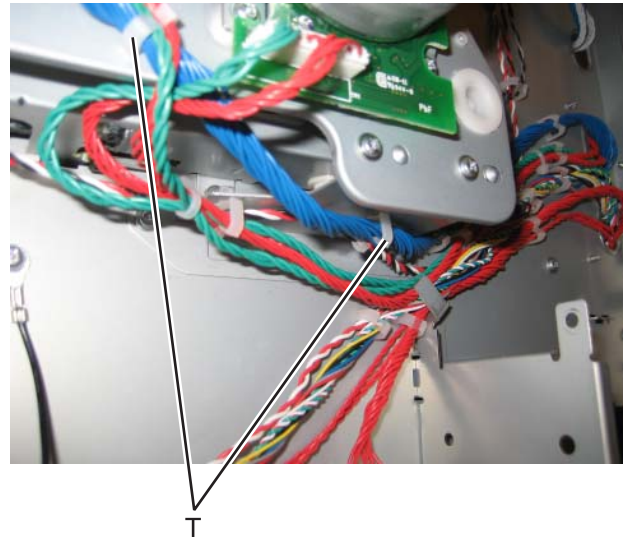
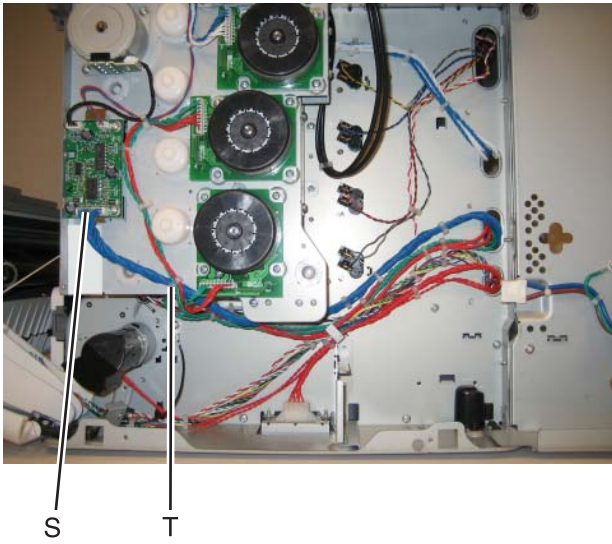

13. Reinstall the low-voltage power supply (LVPS).
14. Replace the right and rear covers.
15. Replace the transport belt module and developer units.
16. Replace the cartridges and the fuser.
17. Replace the paper tray.

Fax modem removal

1. Remove the rear frame cover. See **“Rear frame cover removal”** on page 4-38.
2. Open the left door cover.
3. Loosen the two screws (A) securing the fax modem, and then lift the card to remove it.
4. Disconnect the cable (B) from the connector on the system board. The connector is under the card.

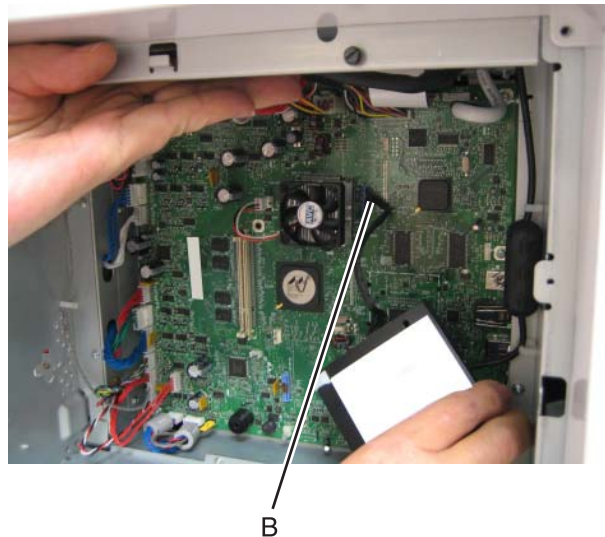
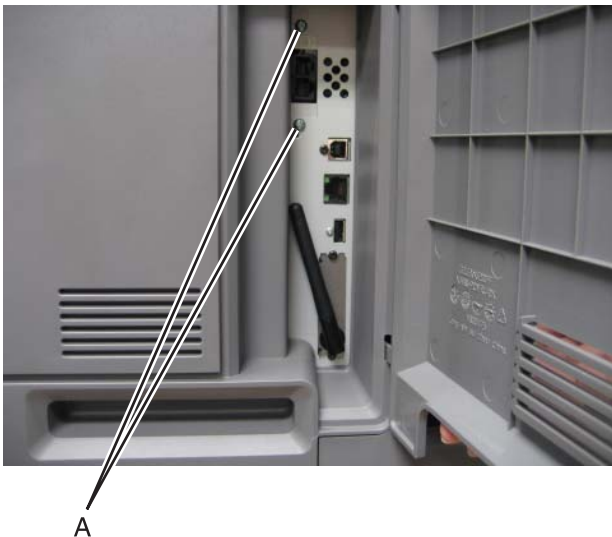

5. Lift, and remove the fax modem.

Front door assembly removal

See the part number for the Front door assembly for the specific model you need on.

1. Remove the front access cover assembly. See **“Front access cover assembly removal”** on page 4-20.
2. Remove the LVPS. See **“Low-voltage power supply (LVPS) removal”** on page 4-104.
3. Disconnect the JTPS1 cable (A) from the system board.

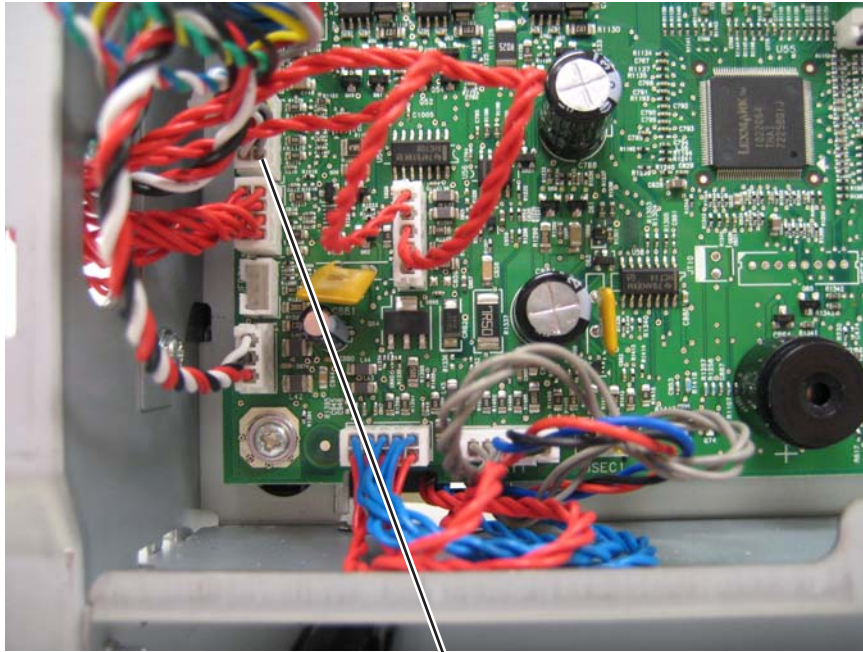

A

4. Release the left and right front door assembly cable.
5. Release the cable springs (B) from the front door assembly.

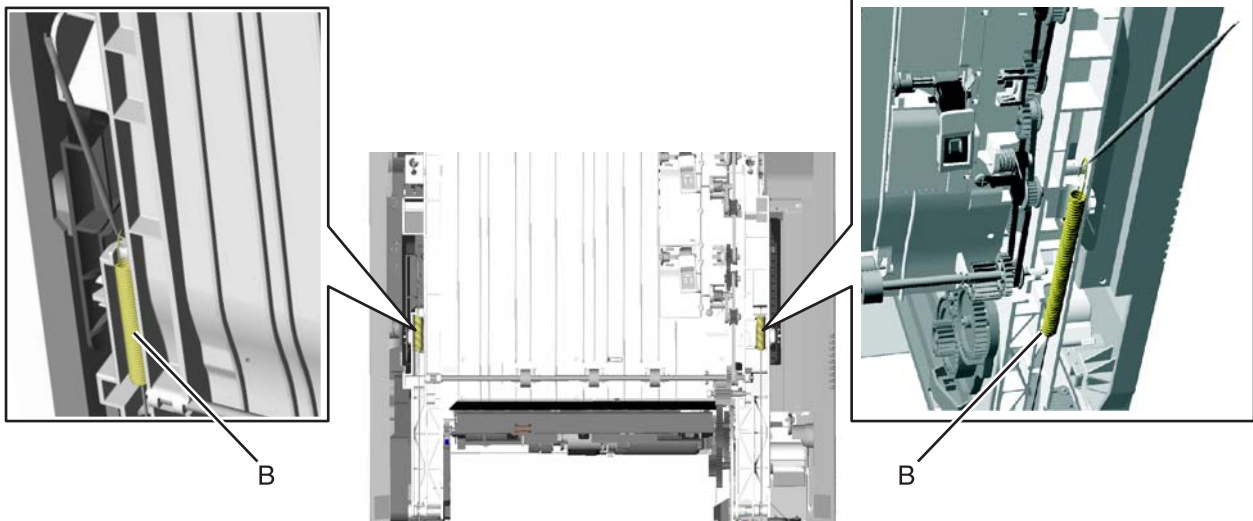

B

B

6. Open the front door assembly.
7. Unwrap and remove the cable from the left and right pulleys (C).

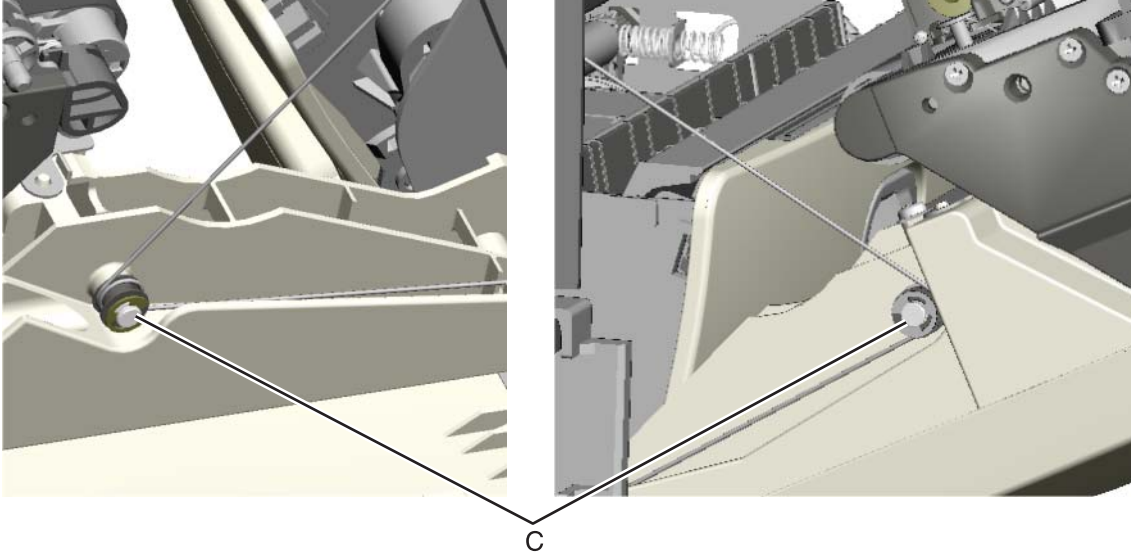

8. Close the front door assembly, and remove the mounting screw (D) and the cap (E).

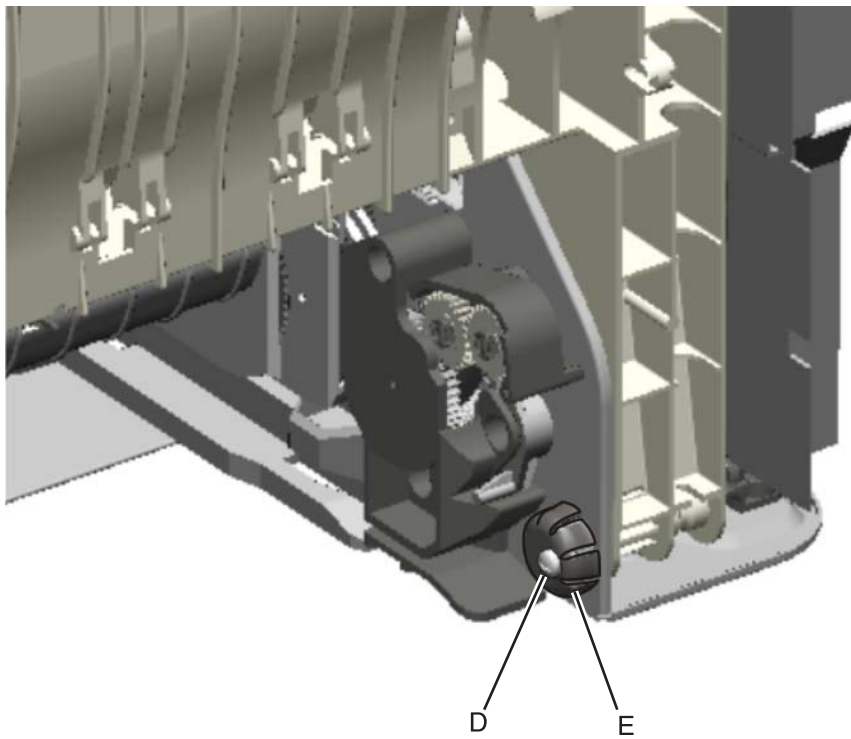

9. Open the front door assembly, slide it to the right, and remove. You need to press firmly to slide the front door assembly to the right.

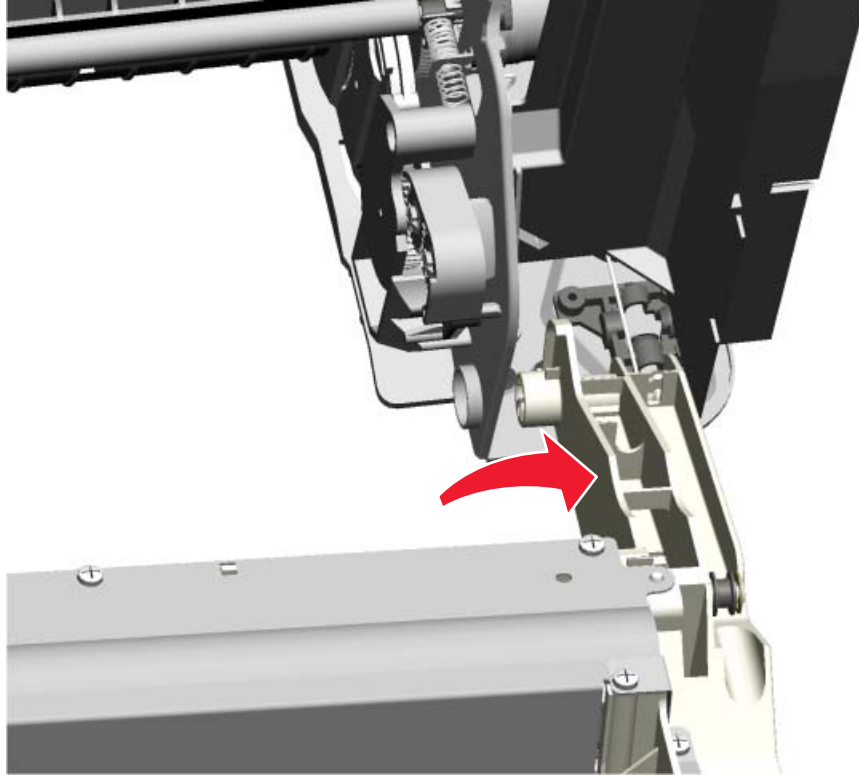

Installation note: See **“Front door assembly front cable (left) removal”** on page 4-86 and **“Front door assembly front cable (right) removal”** on page 4-90 for proper installation of the cable restraints.

Front door assembly front cable (left) removal

1. Remove the paper tray.
2. Disconnect the transfer module cable (A).
3. Press the two tabs (B) to release the front access door cover assembly.
4. Press the two tabs (C) on either side of the transfer module, and lift out the transfer module.

Note: Leave the photoconductor units on the transport belt when removing.

Warning: To avoid damaging the photoconductor drum, hold the photoconductor units by their handle and place the photoconductor units on a clean surface. Never expose the photoconductor units to light for a prolonged period of time. See **“Handling the photoconductor unit”** on page 4-2 for additional information.

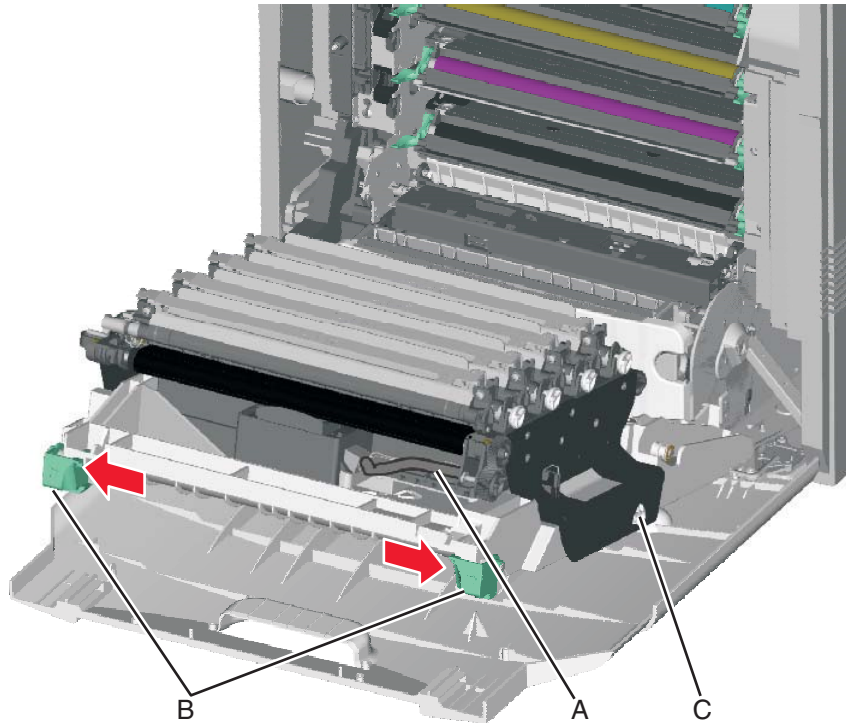

5. Looking down at the keyed end of the restraint (D), twist the end clockwise, slide the restraint upward through the slit (E), and slip the end of the restraint through the keyed hole (F). Repeat for the other side.

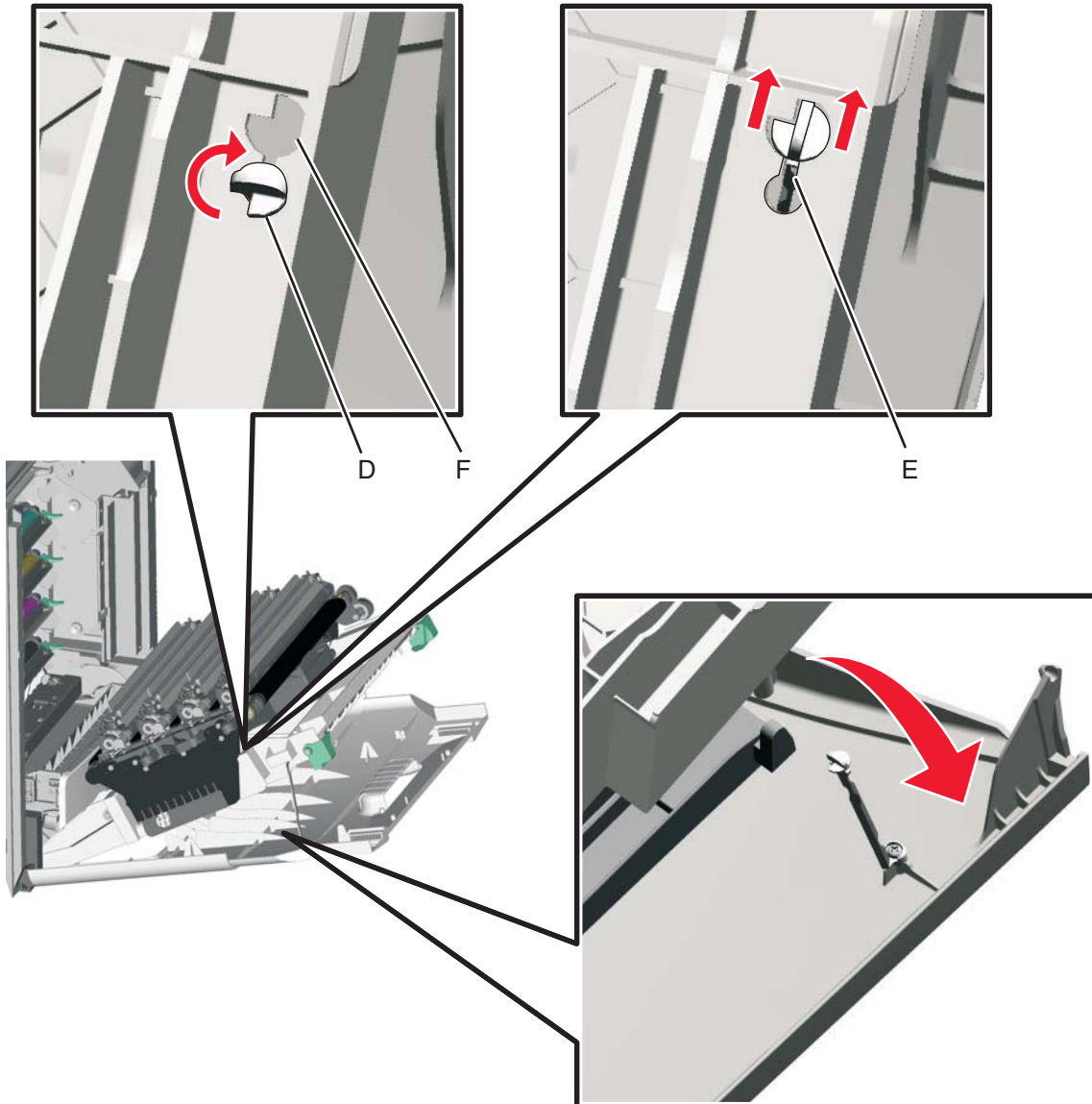

6. Remove the left cover. See **“Left cover removal”** on page 4-23.
7. Close the front access door assembly.
8. Release the cable spring (G) from the front door assembly.
Note: In order to access the springs, make sure the top access cover is closed.

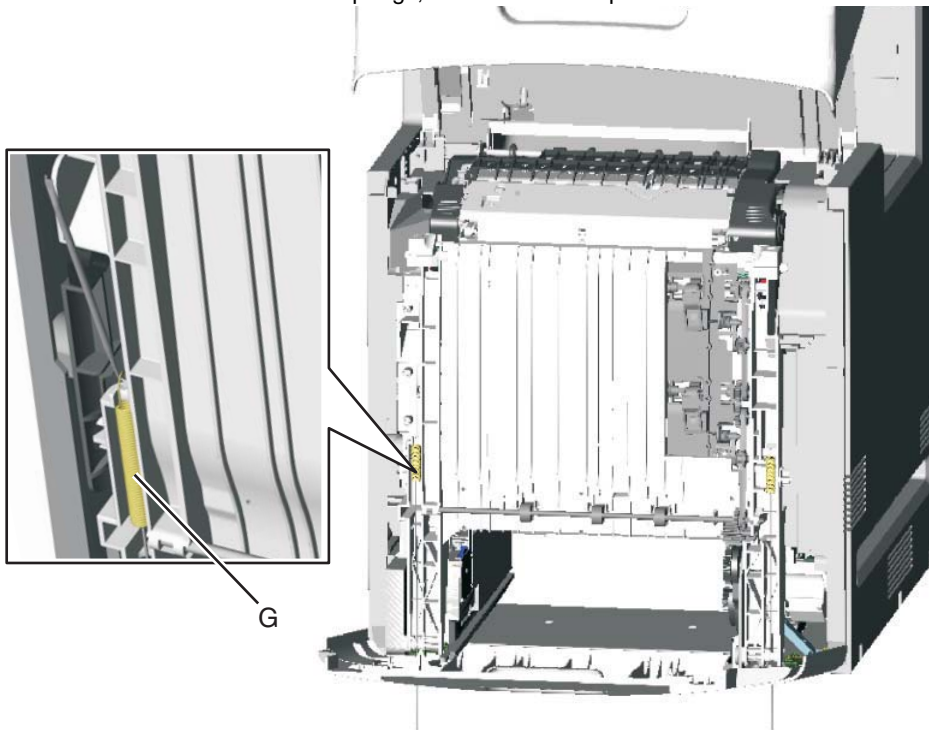

9. Remove the end of the cable (J) from the frame.

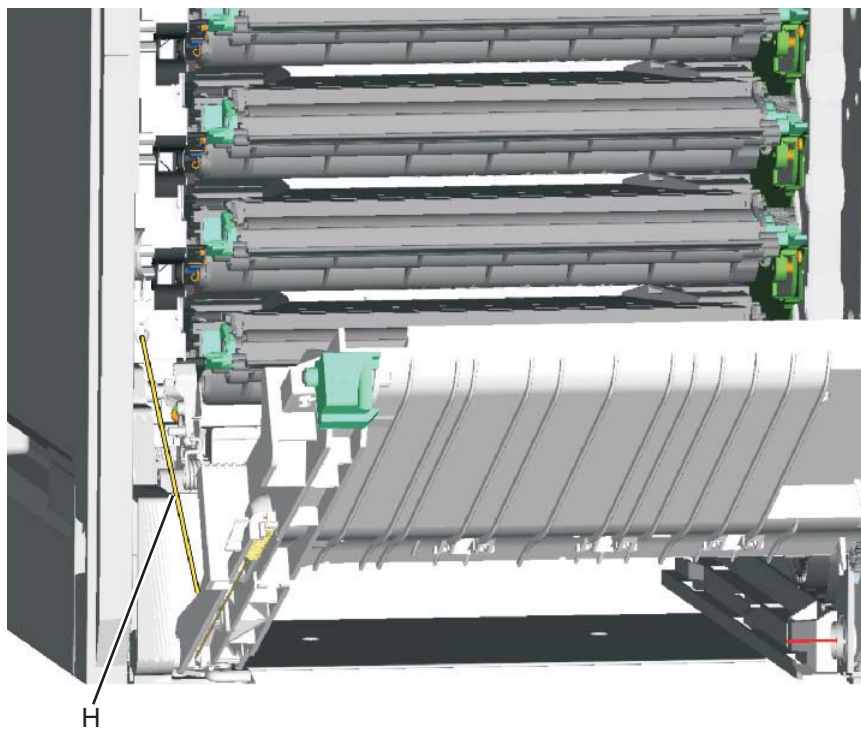

10. Open the front door assembly, and using a flathead screwdriver, rotate the top cover camshaft clockwise to raise the front door locking mechanism (J).

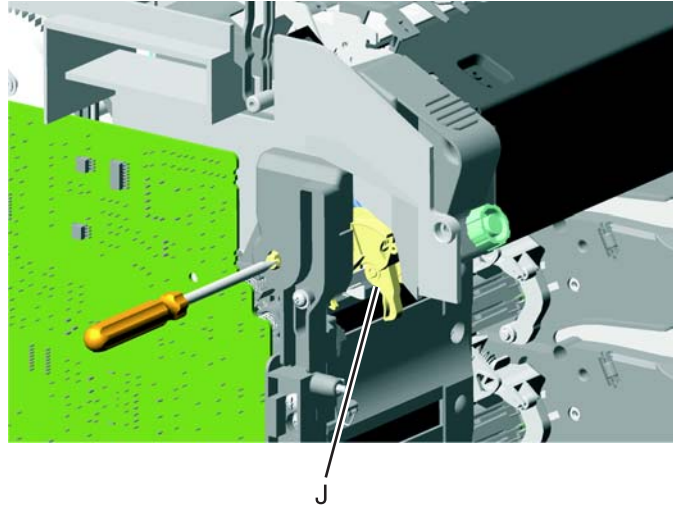

Installation note:

Note: The longer cable installs on the left side of the printer.

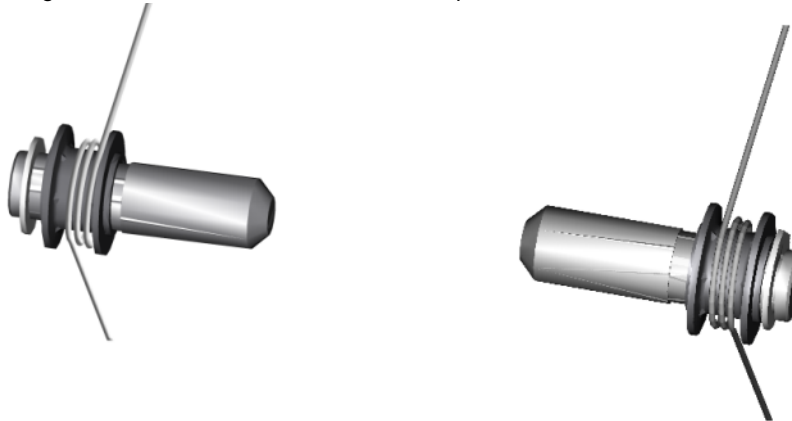

Front door assembly front cable (right) removal

1. Remove the paper tray.
2. Disconnect the transfer module cable (A).
3. Press the two tabs (B) to release the front access door cover assembly.
4. Press the two tabs (C) on either side of the transfer module, and lift out the transfer module.

Note: Leave the photoconductor units on the transport belt when removing.

Warning: To avoid damaging the photoconductor drum, hold the photoconductor units by their handle and place the photoconductor units on a clean surface. Never expose the photoconductor units to light for a prolonged period of time. See **"Handling the photoconductor unit"** on page 4-2 for additional information.

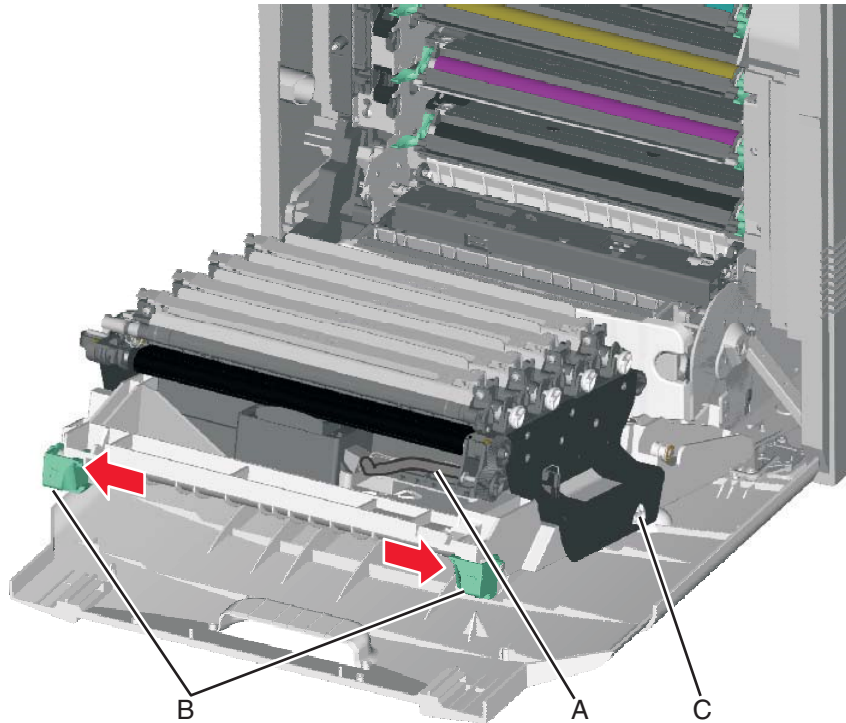

5. Looking down at the keyed end of the restraint (D), twist the end clockwise, slide the restraint upward through the slit (E), and slip the end of the restraint through the keyed hole (F). Repeat for the other side.

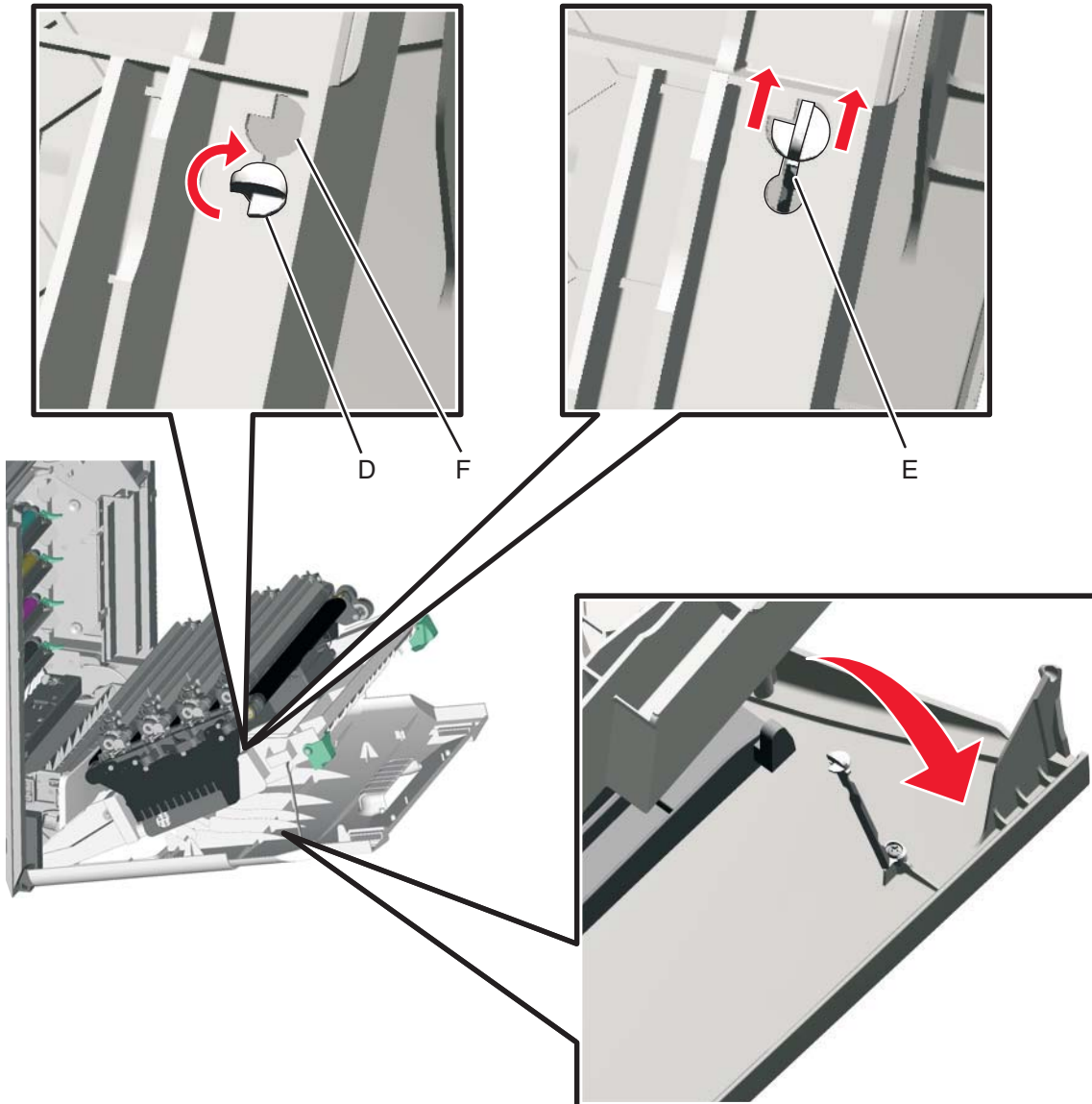

6. Close the front access door assembly.
7. Release the spring (G) from the front door assembly.
Note: In order to access the springs, make sure the top access cover is closed.

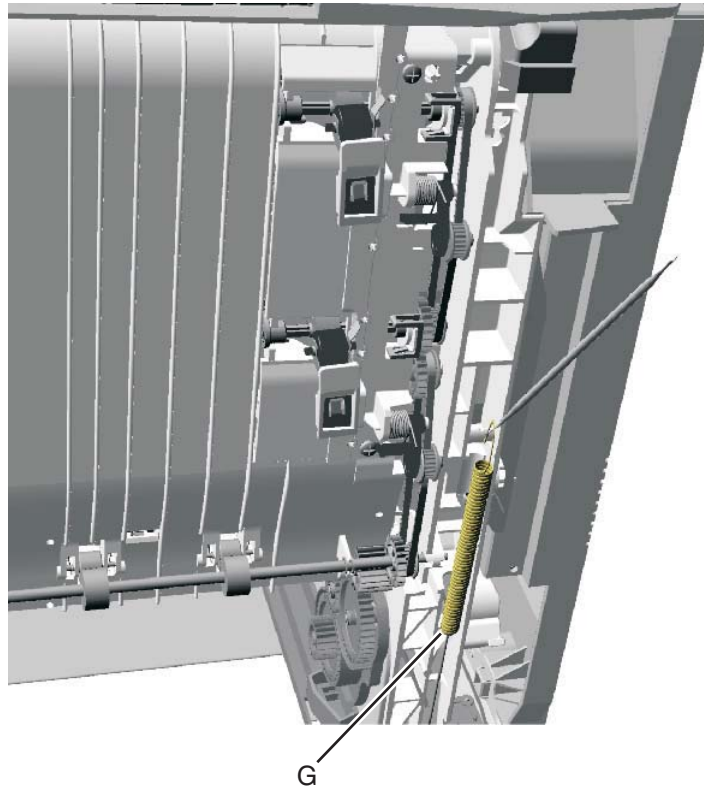

8. Remove the end of the cable (H) from the frame.

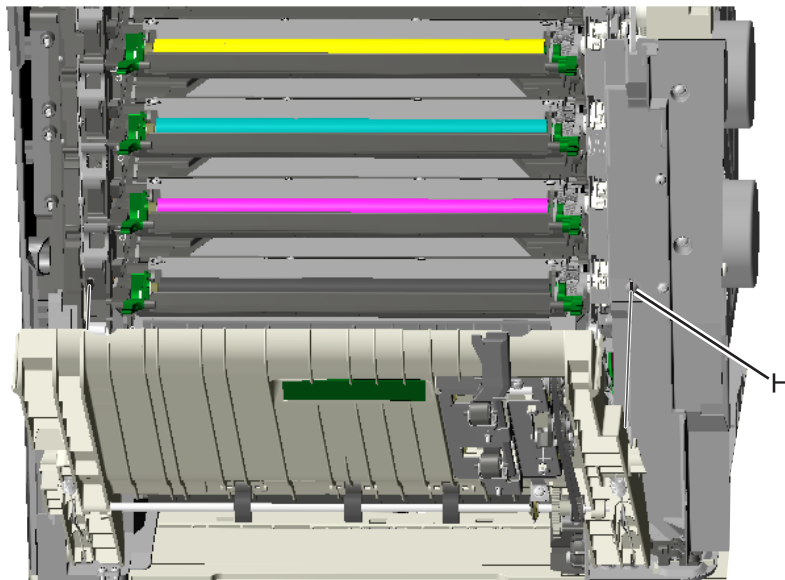

9. Remove the right restraint cable.

Installation notes:

The shorter restraint cable installs on the right side of the printer.

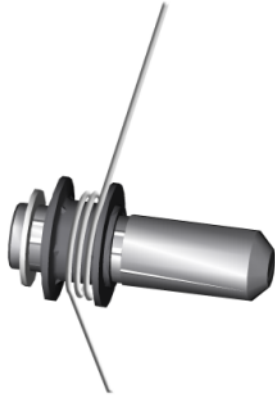

Fuser assembly removal

See **“Fuser assembly, 115 V”**, **“Fuser assembly, 230 V”**, or **“Fuser assembly, 100 V”** on page 7-5 for the part number.

	<p>CAUTION</p> <p>The fuser can be extremely hot. Use care when handling to avoid burns.</p>
---	---

1. Turn off the printer.
2. Open the top access door.
3. Open the front access door.
4. Rotate the fuser thumbscrews (A) counterclockwise until loosened.
5. Grasp the handles (B), slide the fuser out from the printer.

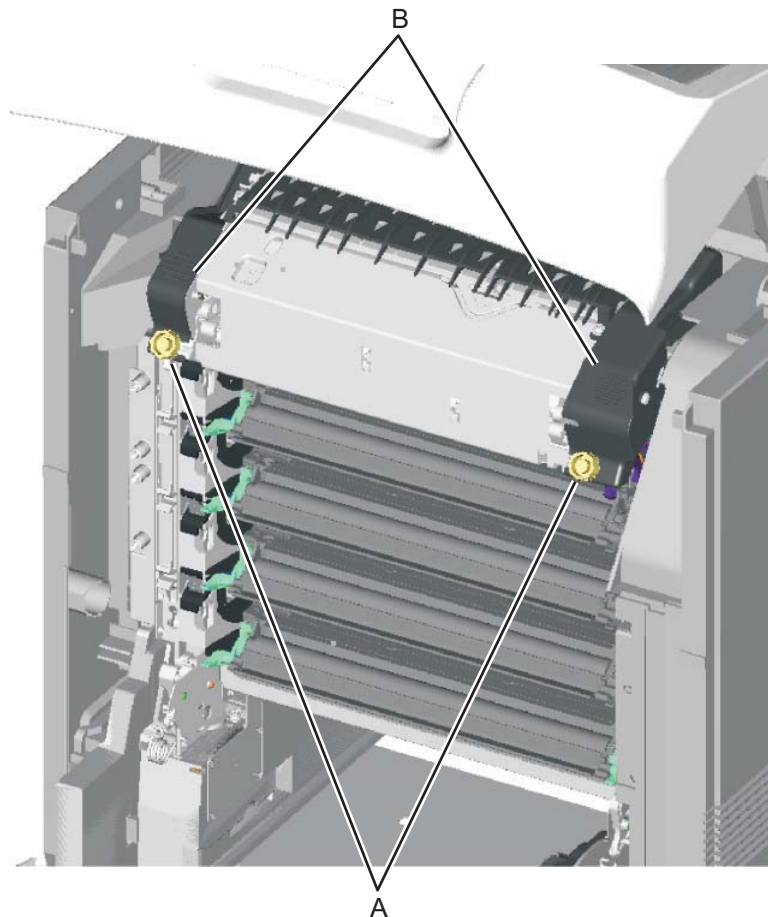

Installation note: If you install a new fuser, be sure to reset the fuser counter in the Configuration Menu. To reset the counter:

1. Turn off the multifunction printer, press and hold **2** and **6**, turn on the MFP, and release the buttons when the progress bar displays.
2. Touch **Reset Fuser Cnt** from the Config Menu.
3. Touch **Yes** or **No**.
4. Select **Exit Config Menu**.

See **“Reset Fuser Count”** on page 3-31.

Fuser AC cable removal

Note: The LVPS to fuser AC cable is black.

1. Remove the top cover assembly. See **“Top cover assembly removal”** on page 4-45.
2. Turn the top cover assembly over.
3. Slide the connector down, and remove the connector from the keyed hole (A).

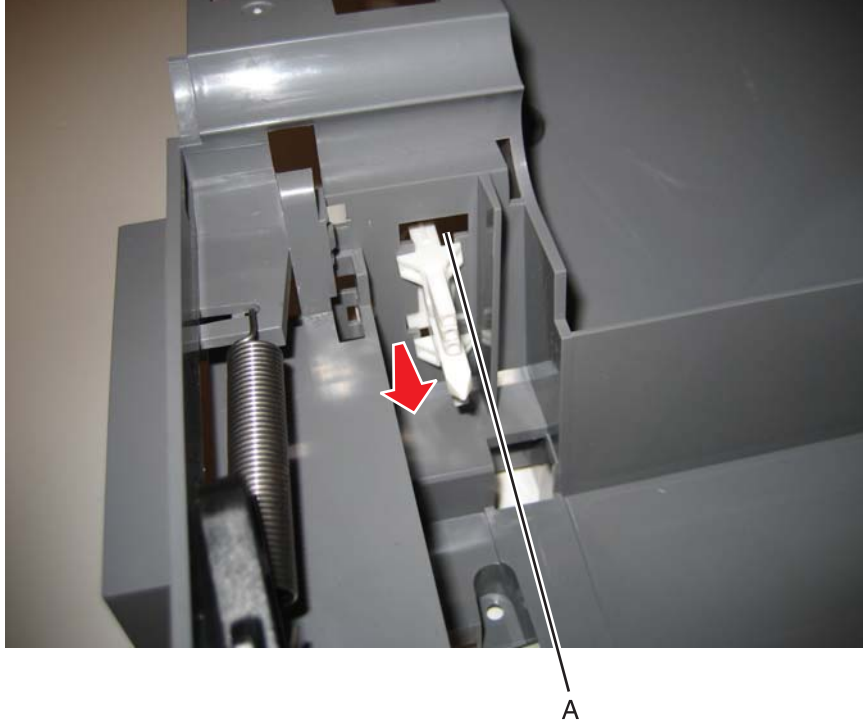

4. Remove the cable from the cable openings (B).
Note: Observe the routing of the cable for reinstallation.

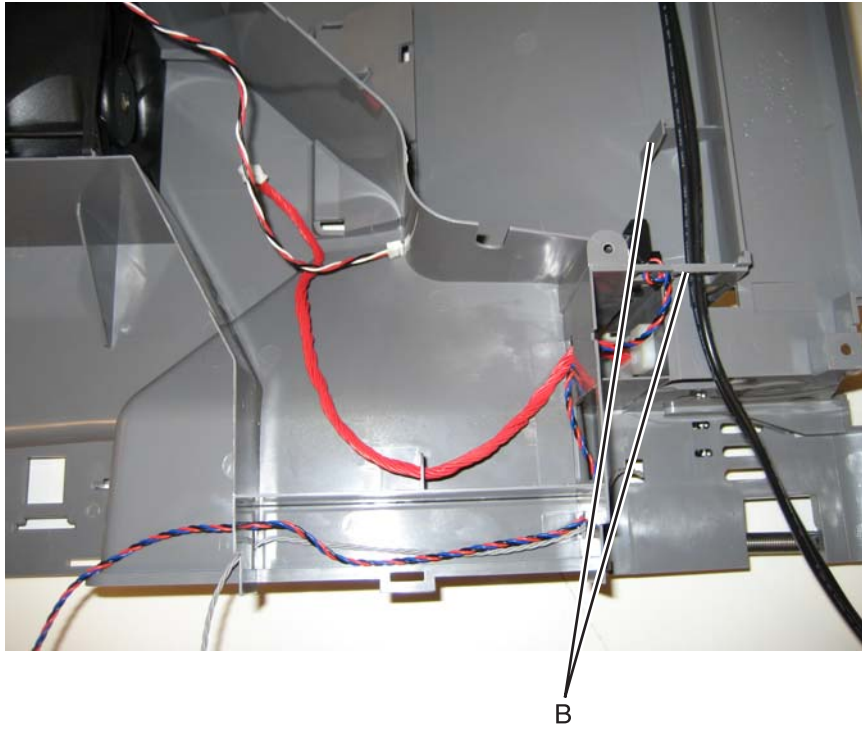

5. Remove the cable from the cable restraint (C) on the right side, and remove the cable.

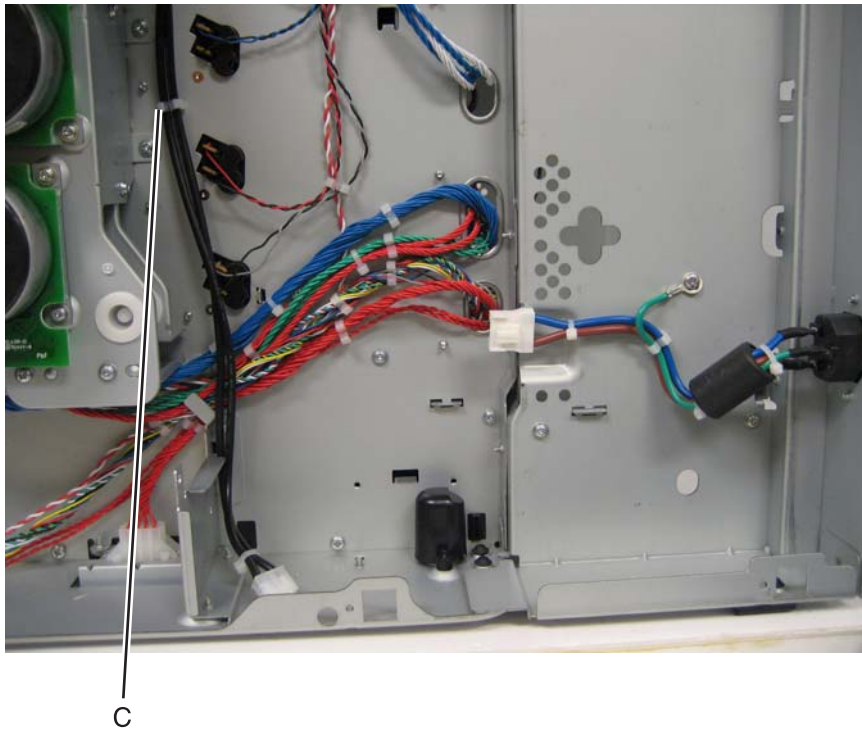

Fuser DC cable removal

Note: The fuser to system board autoconnect cable is red.

1. Remove the top cover assembly. See **“Top cover assembly removal”** on page 4-45.
2. Turn the top cover assembly over.
3. Remove the connector (A) from the top cover assembly.
Warning: You will damage the old connector in the process. Be careful not to damage the top cover assembly.
4. Pull the cable through the openings (B) in the top cover assembly.

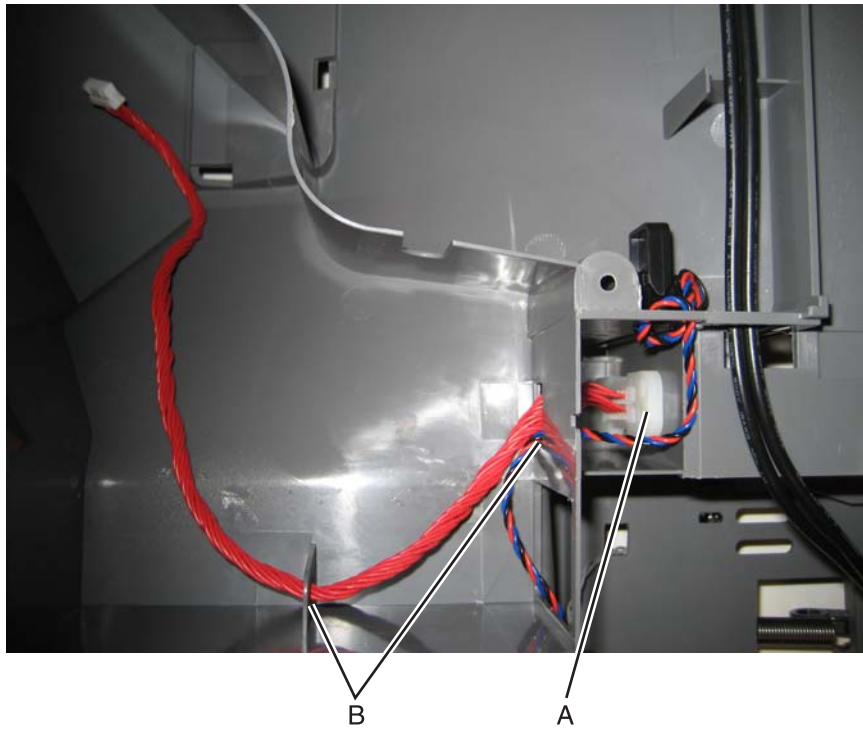

Hard drive assembly removal

1. Remove the rear frame cover. See **“Rear frame cover removal”** on page 4-38.
2. Press the locking tab (A) as you disconnect the hard disk cable from the system board (B).

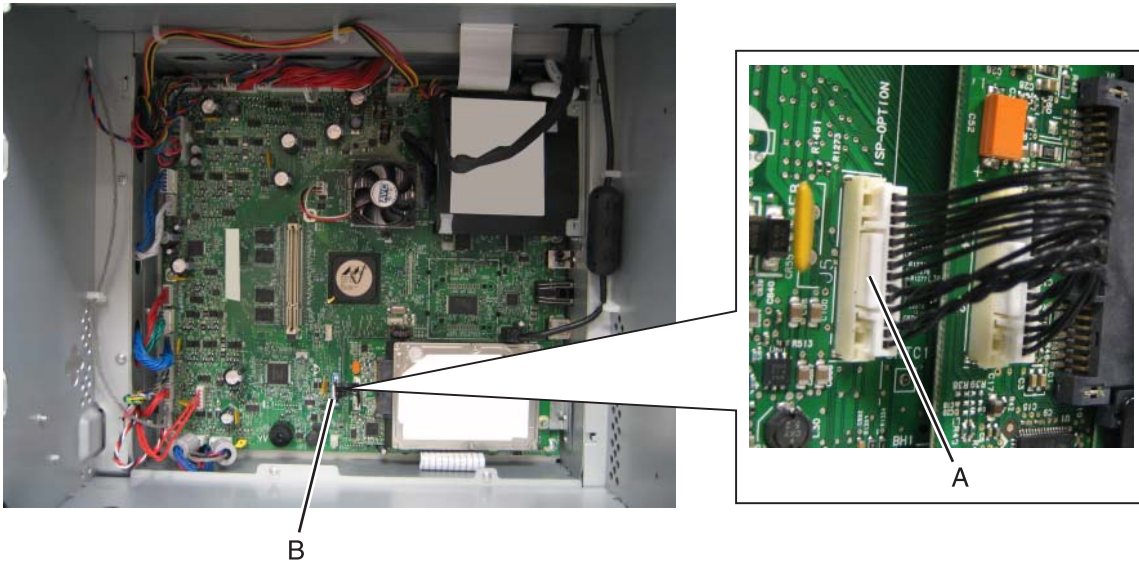

3. Open the left cover door, and remove the two screws (C).



4. Pull the hard disk straight out to *pop* the hard disk standoffs free of the system board.

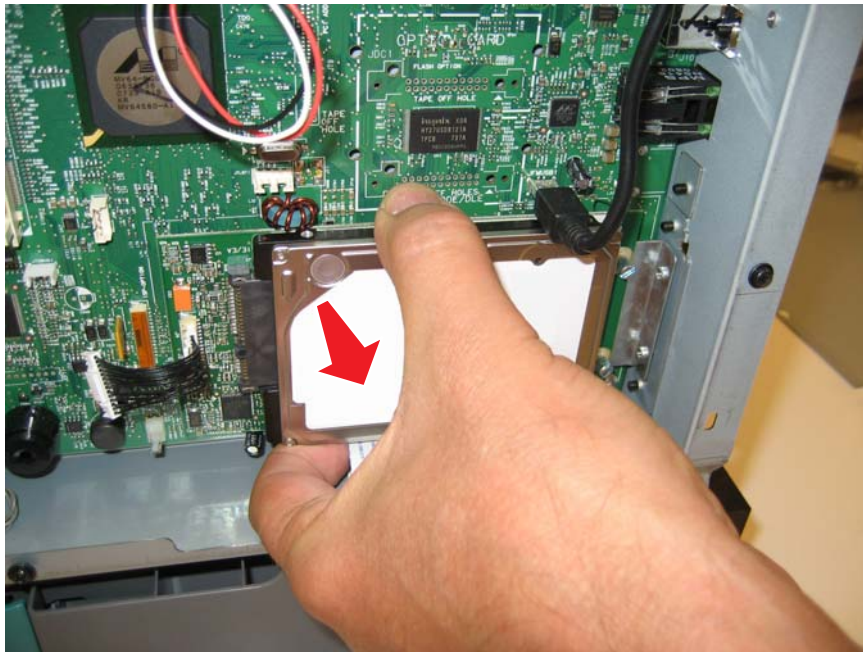

High-voltage power supply (HVPS) removal

See “**High-voltage power supply**” on page 7-11 for the part number.

1. Remove the left cover. See “**Left cover removal**” on page 4-23.
2. Remove the six mounting screws (A).

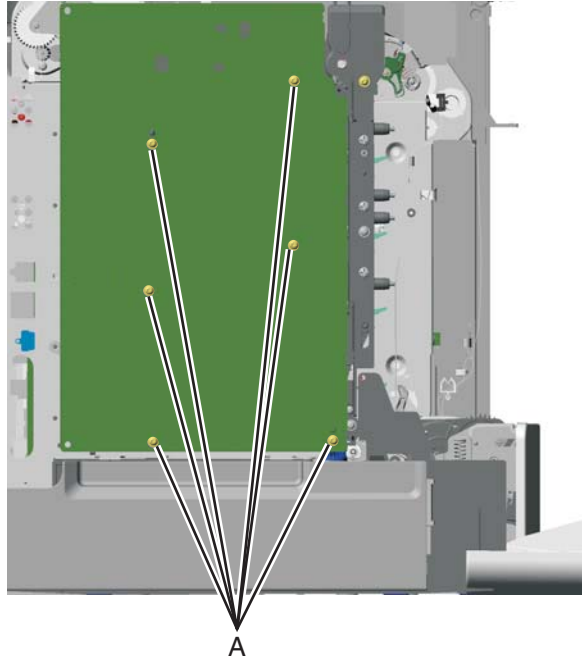

3. Release the locking tab (B) from the front, lower corner of the HVPS.

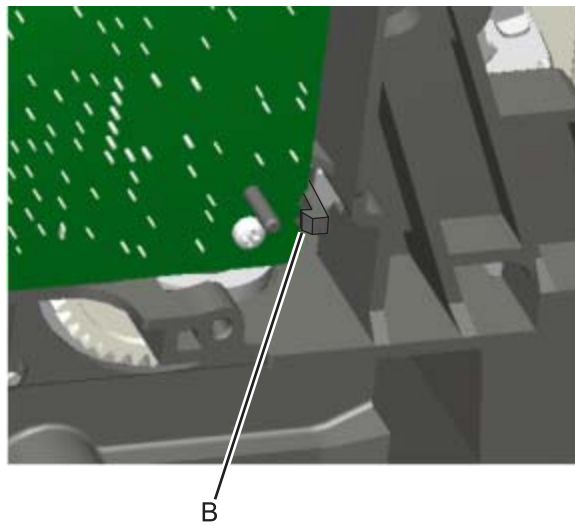

4. Disconnect the five connectors (C) from the HVPS.

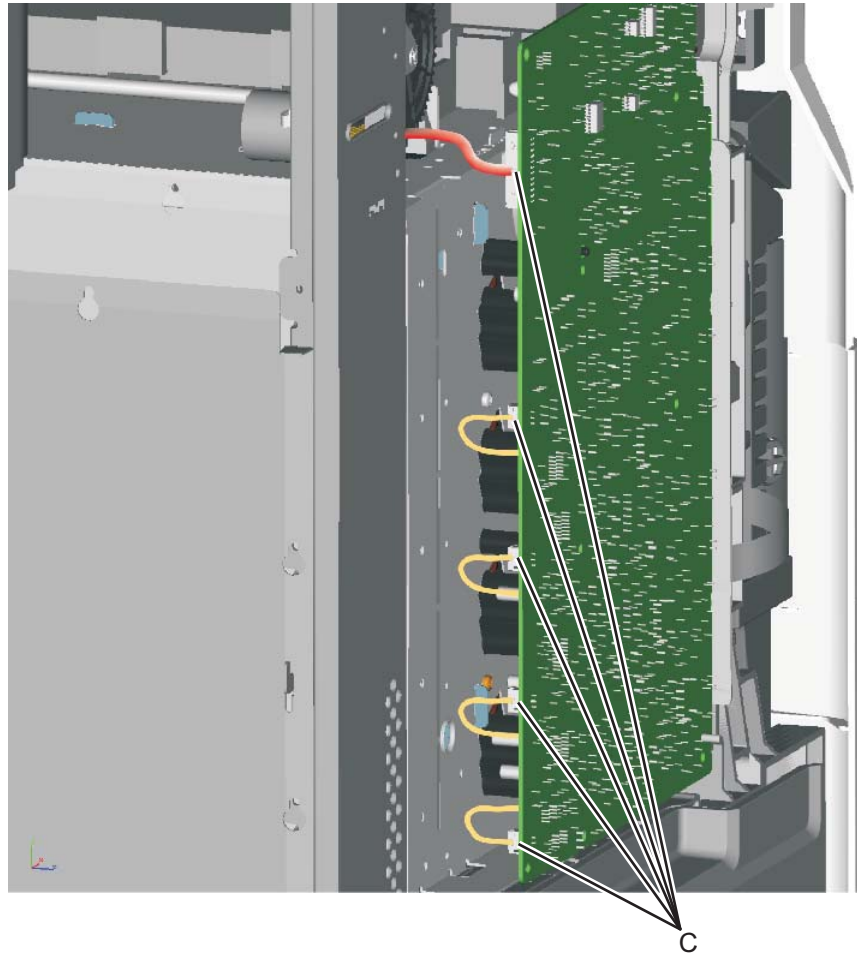

Installation notes: Be sure to replace the spring when replacing the HVPS. See the illustration for proper orientation.

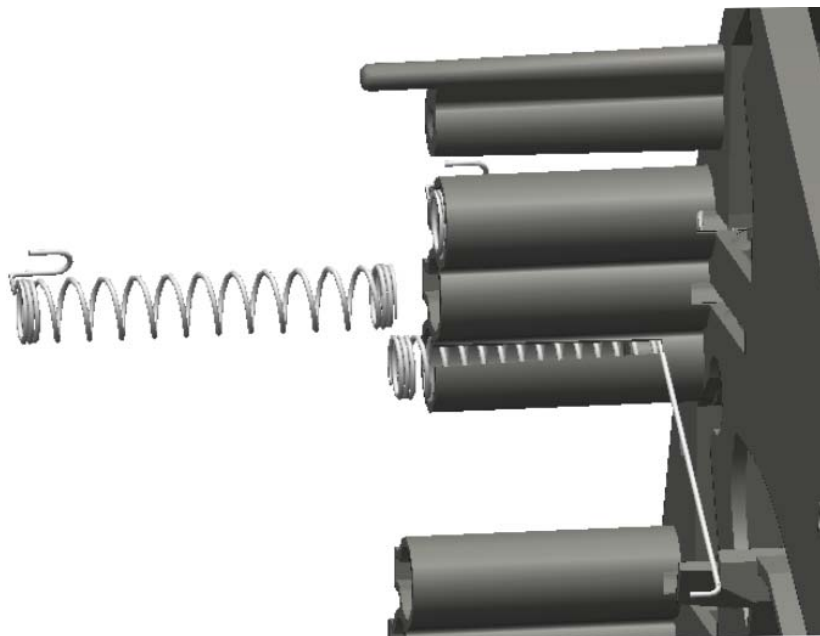

High-voltage power supply (HVPS) cable removal

1. Remove the top cover assembly. See **“Top cover assembly removal”** on page 4-45.
2. Disconnect the cable connector at JHVPS1 (A) on the system board, and extract the cable through the opening (B) in the frame.

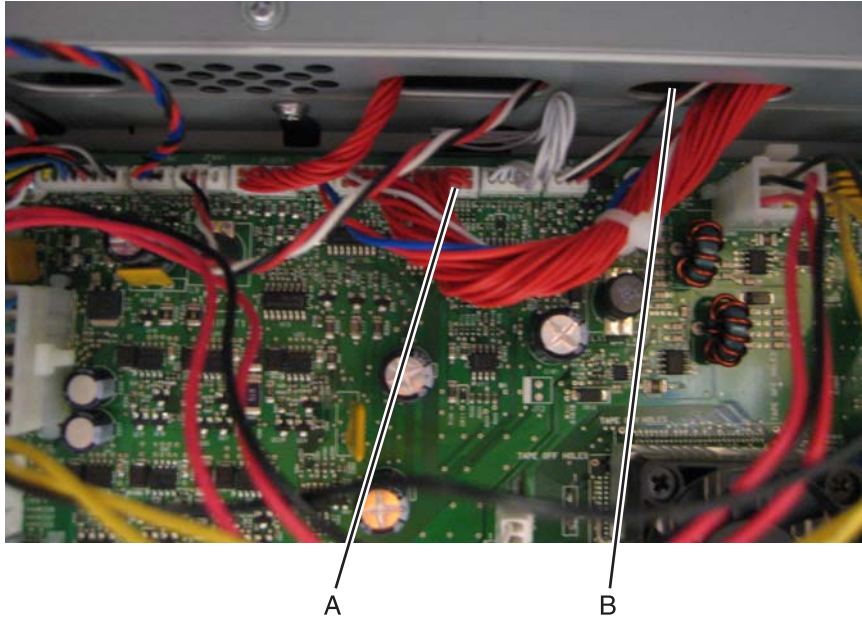

3. Disconnect the cable connector (C) from the back of the HVPS.
4. Remove the cable from the two cable restraints (D).

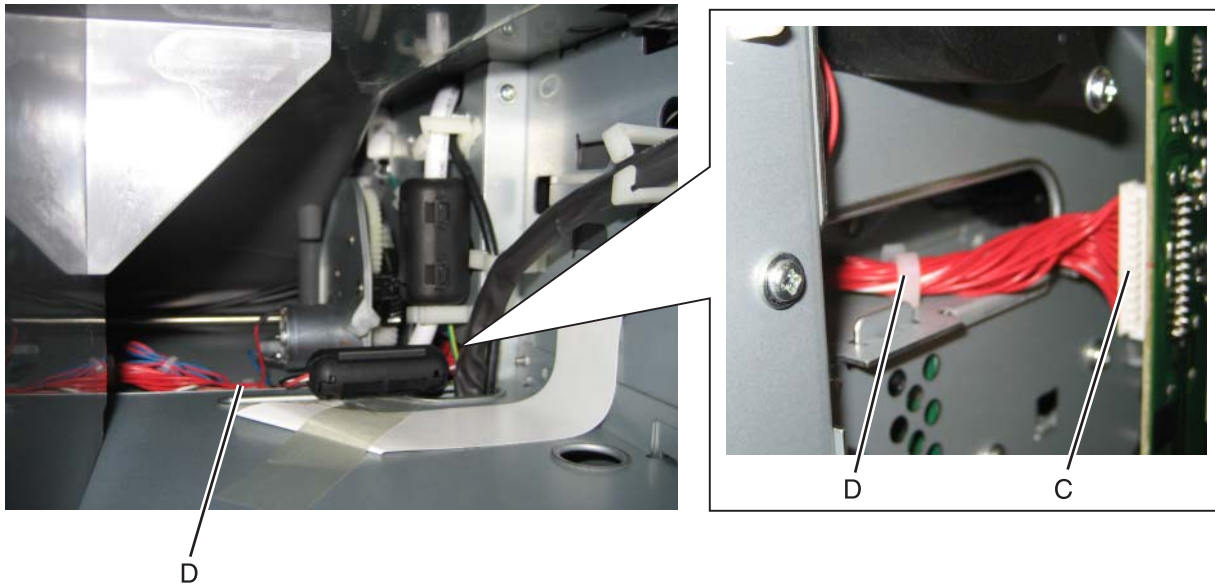

Left bellcrank assembly removal

See for the part number.

1. Remove the left cover. See **“Left cover removal” on page 4-23.**
2. Remove the C-clip (A).

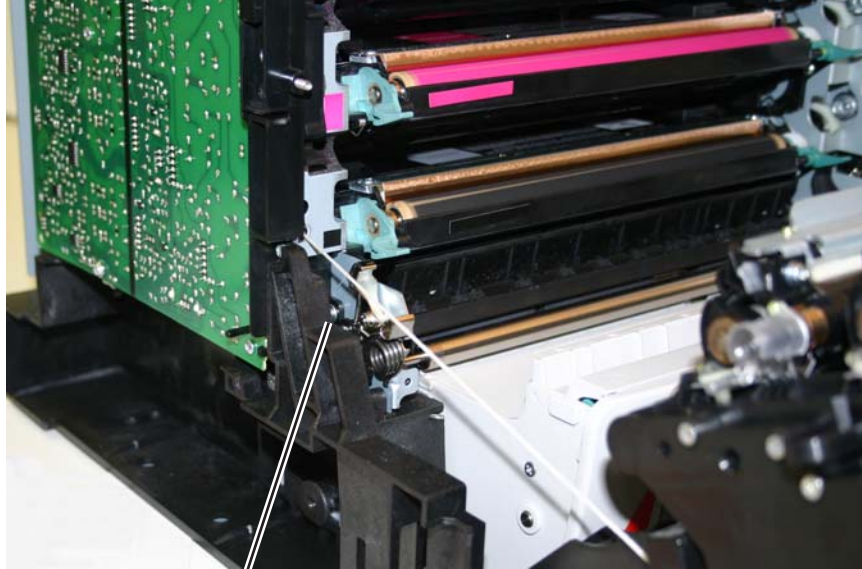

A

3. Remove the left bellcrank assembly.

Low-voltage power supply (LVPS) removal

See “**Low-voltage power supply**” on page 7-7 for the part number.



1. Remove the right cover. See “**Right cover removal**” on page 4-39.
2. Remove the rear frame cover. See “**Rear frame cover removal**” on page 4-38.
3. Disconnect the connector at JLVPS1 connector (A) and at JLVPS2 (B) on the system board.
4. Remove the cable from the cable restraints (C).

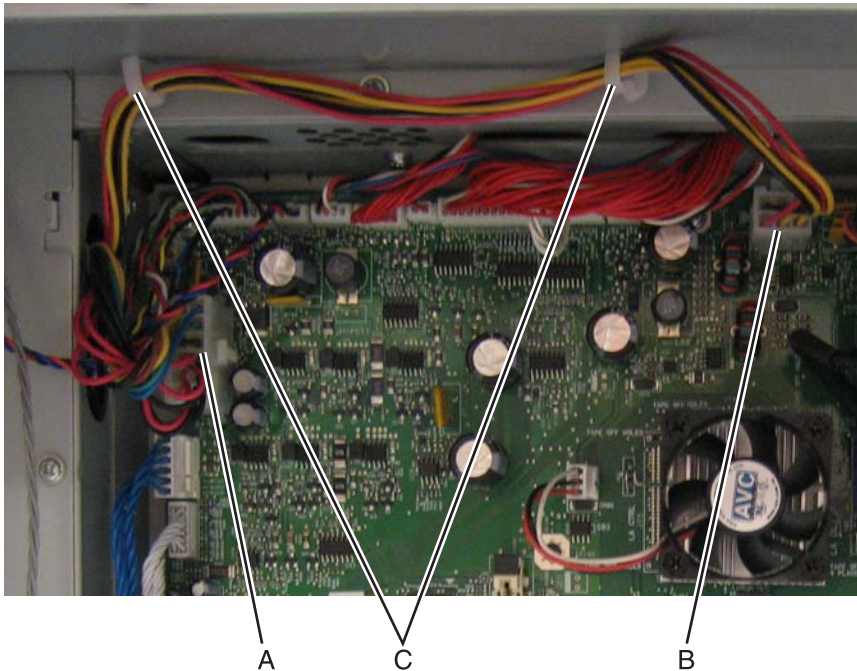

- c. Remove the five LVPS mounting screws (D).
- d. Press the latch and pull back to disconnect the fuser AC cable from the LVPS (E).

- e. Press the latch and pull back to disconnect the power AC cable from the LVPS (F).

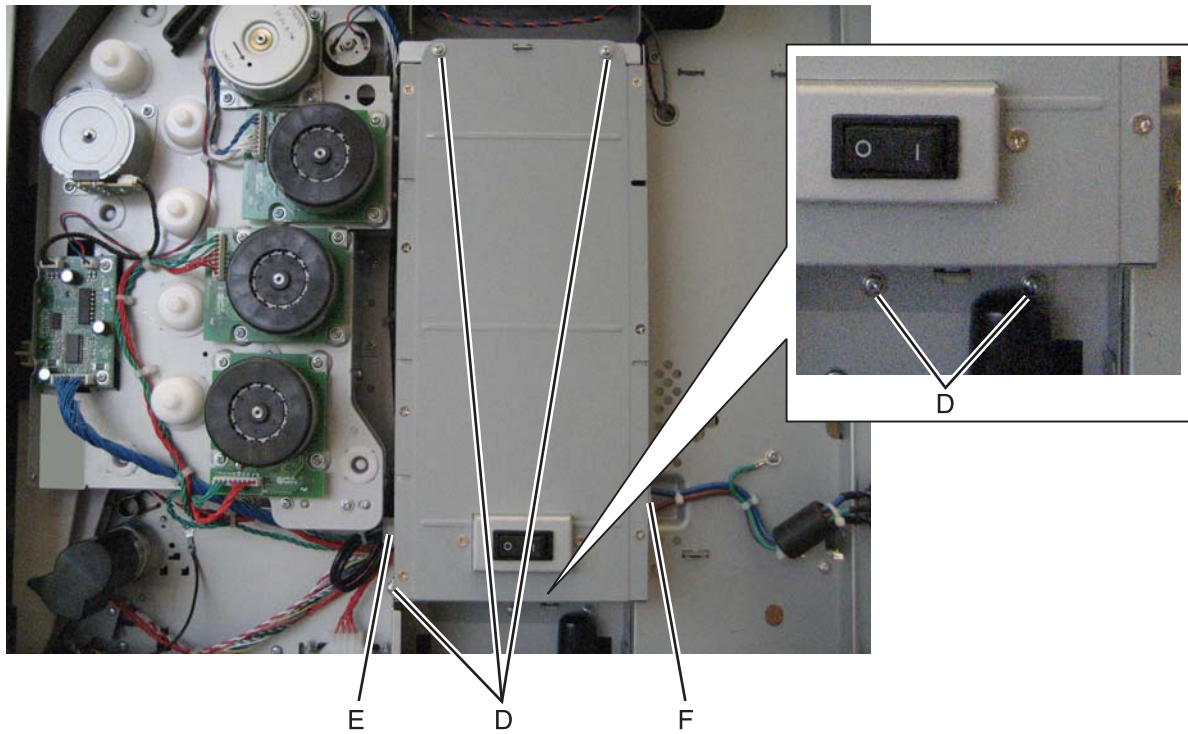

Installation note:

- When installing the new LVPS, make sure the voltage switch (A) is set for the proper value (115 V or 230 V), depending on the country.



- Install the LVPS, and make sure the fuser AC cable is in the cable guides, and not behind the LVPS.
- Reconnect the fuser AC cable to the LVPS.
- Replace the five LVPS mounting screws.
- Reconnect the cable in connector JLVP1 on the system board.

Motor driver cable removal

1. Remove the LVPS. See **“Low-voltage power supply (LVPS) removal”** on page 4-104.
2. Disconnect the connector in JDVR1 (A) on the system board.

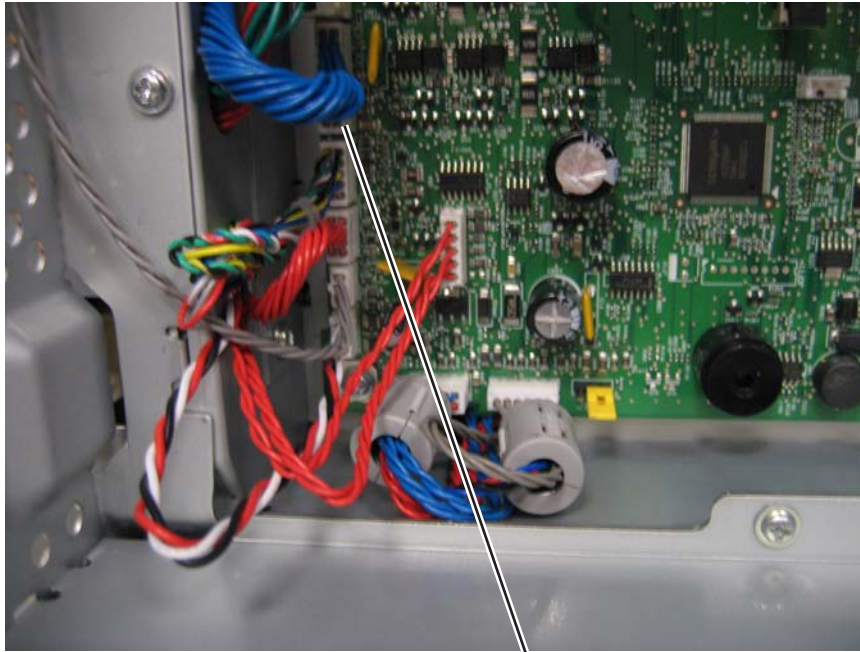

A

3. Disconnect the connector on the motor driver card (B).
4. Remove the cable from the cable from the four cable retainers (C).

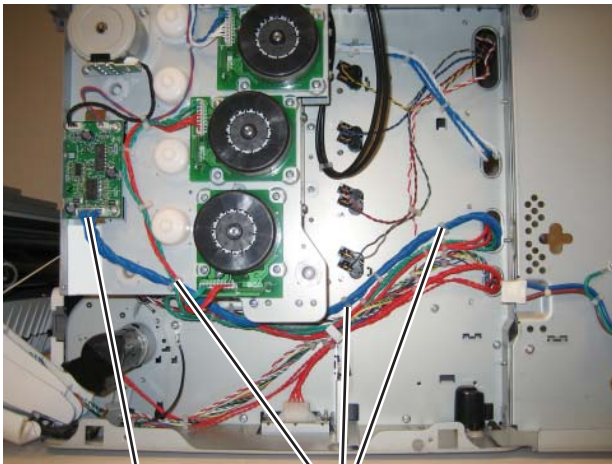

B

C



C

Installation notes

Note the routing of the cable and the cable retainers.

Motor driver card removal

1. Remove the right cover. See **“Right cover removal”** on page 4-39.
2. Disconnect the three cables (A).
3. Remove the two screws (B), and remove the motor driver card.

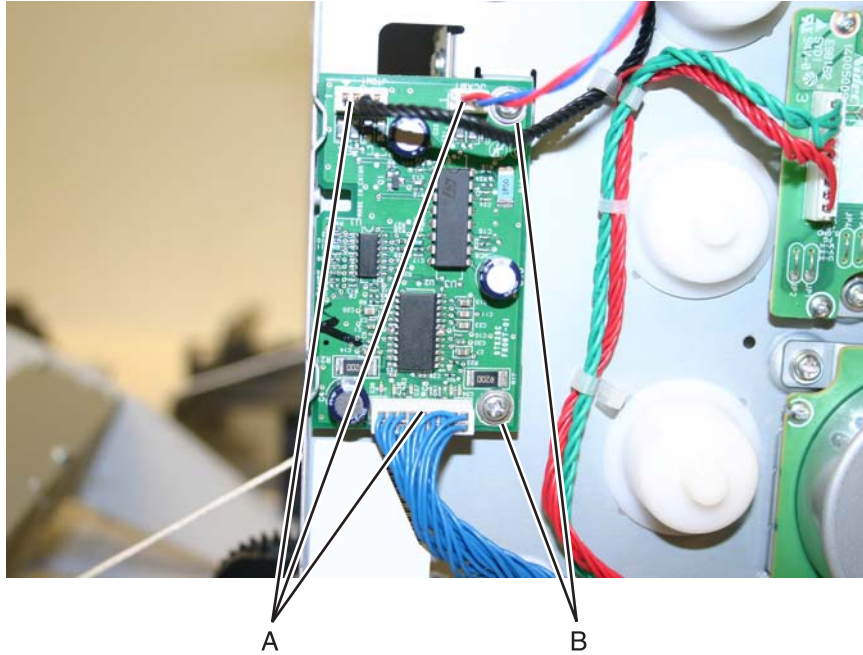

Multipurpose feeder (MPF)/duplex gear and housing removal

See the multipurpose feeder/duplex gear and housing kit on for the part number.

1. Remove the paper pick mechanism assembly. See **“Paper pick mechanism assembly removal”** on **page 4-117**.
2. Remove the two E-clips (A) from the gears.

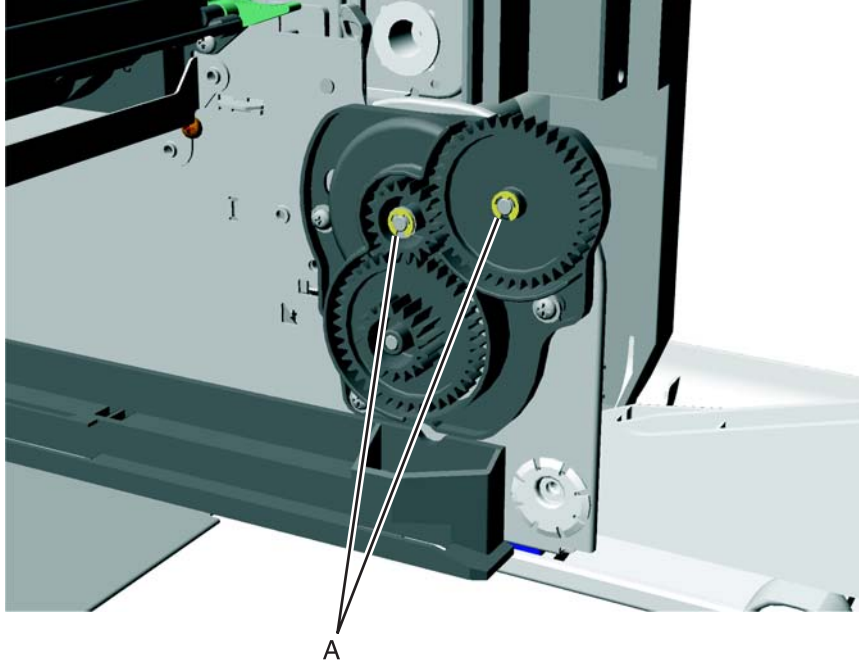

3. Remove the three screws (B).
4. Slide the front gear (C) off.

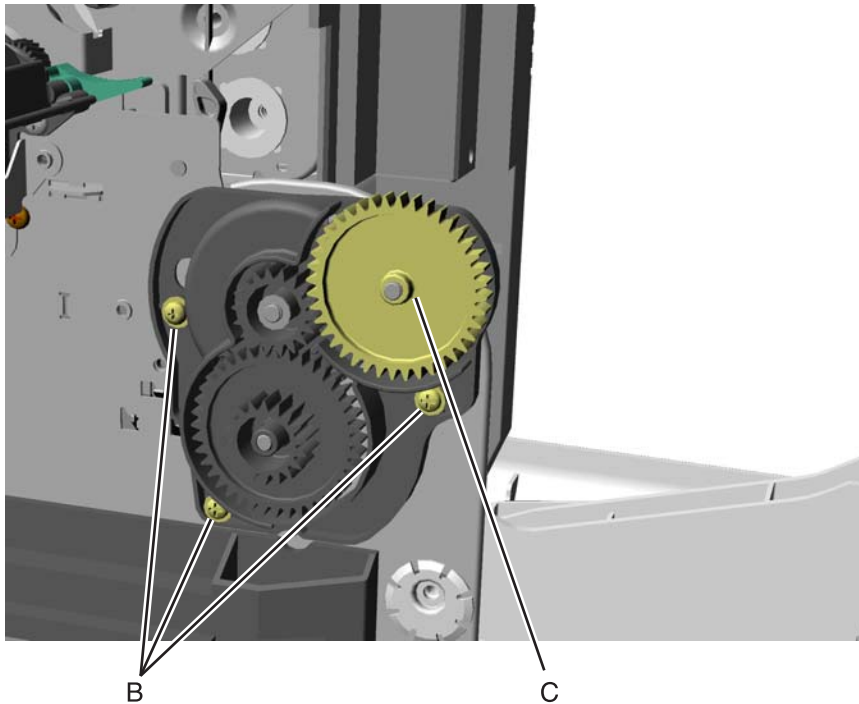

5. Slide a flathead screwdriver up and under the front cover.
6. Slide the remaining two gears and housings off.

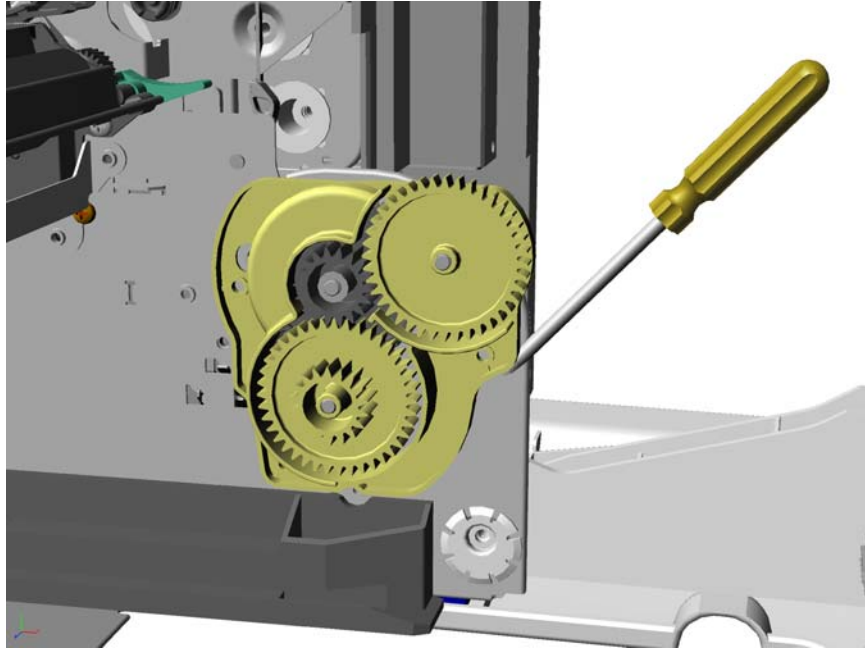

Multipurpose feeder (MPF)/duplex motor assembly removal

See **“MP feeder/duplex motor”** on page 7-7 for the part number.

1. Remove the low-voltage power supply (LVPS). See **“Low-voltage power supply (LVPS) removal”** on page 4-104.
2. Remove the multipurpose feeder/duplex gear and housing. See **“Multipurpose feeder (MPF)/duplex gear and housing removal”** on page 4-108.
3. Remove the two multipurpose feeder/duplex motor mounting screws (A).

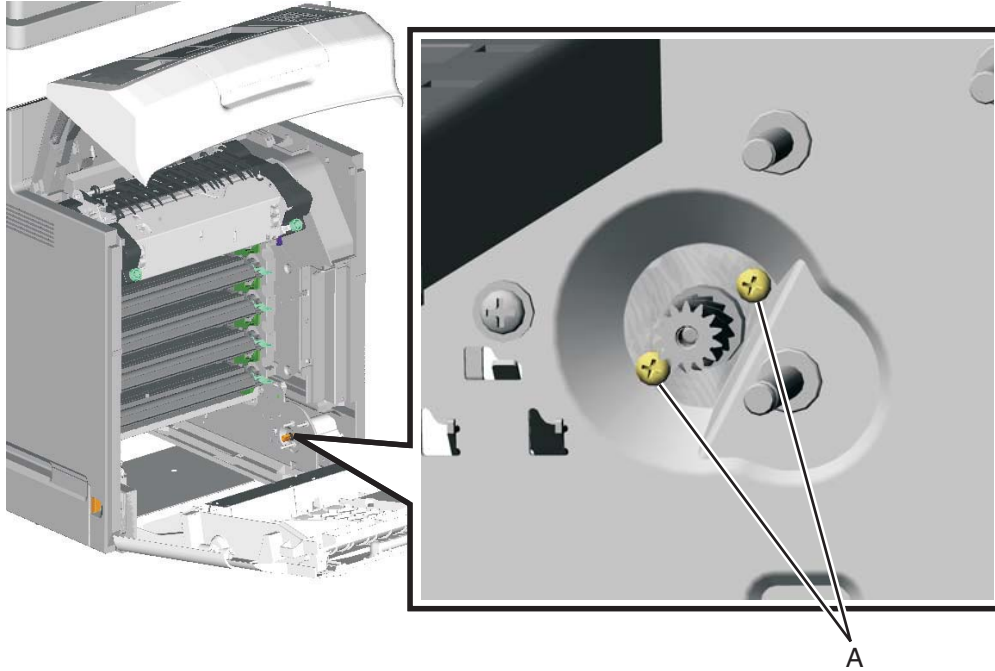

4. Remove the multipurpose/duplex motor from the printer.
5. Push in the prongs (B) of the housing in to remove the cable tie (C).

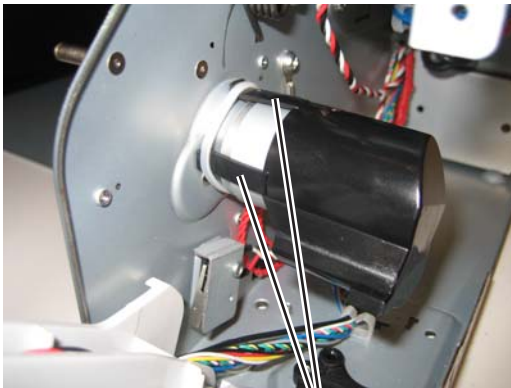

6. Slide the motor out of the housing.
7. Disconnect the connector (D) from the motor.

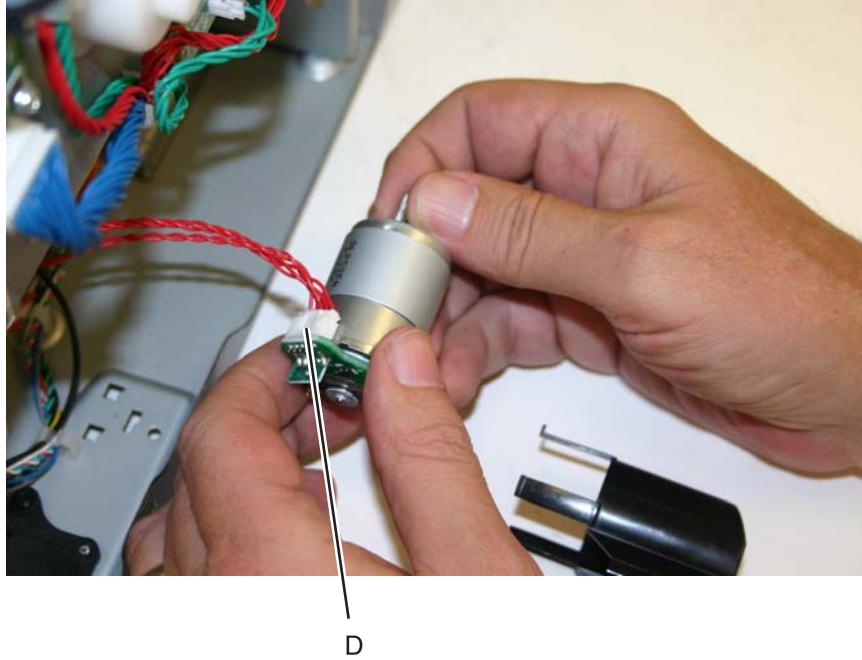

Installation notes:

1. Connect the cable (A) at the motor.
2. Slide the cable tie (B) onto the motor.

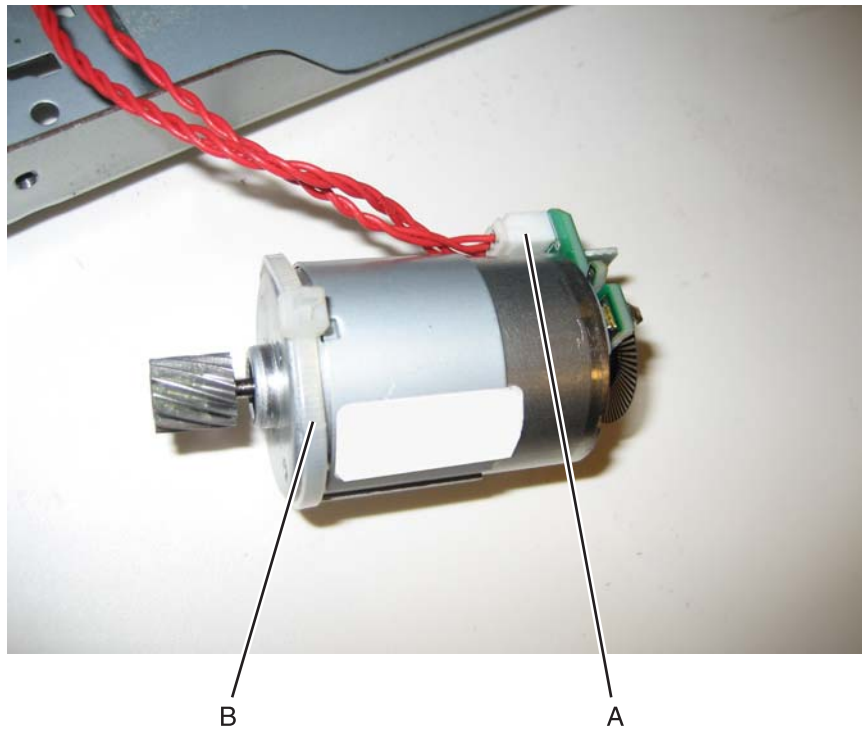

3. Insert the motor into the frame.

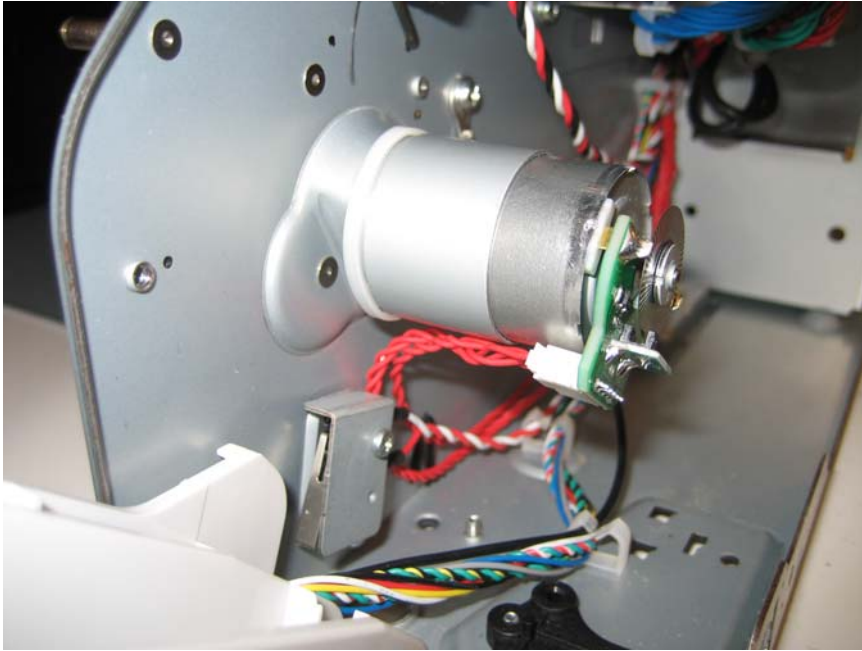

4. Replace the screws (C).

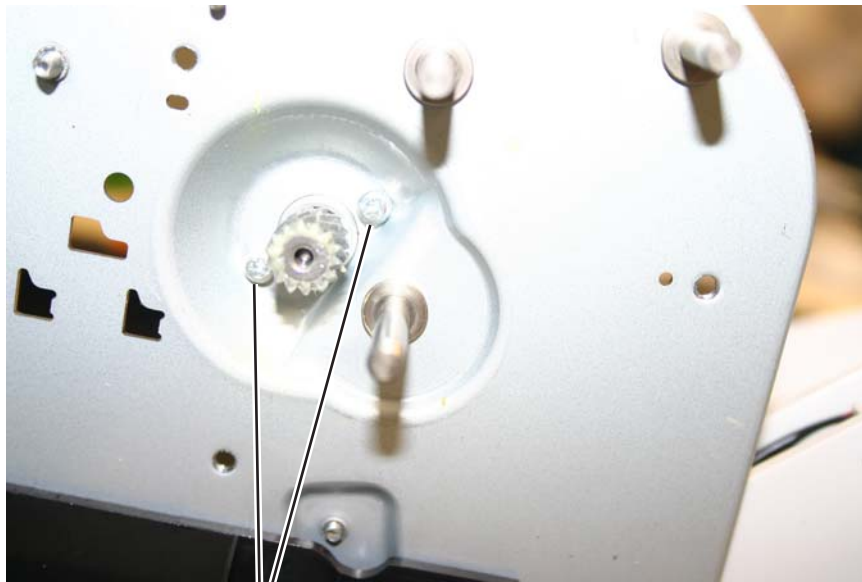

C

5. Slide the housing onto the motor, making sure the four tabs of the housing slide under the cable tie.

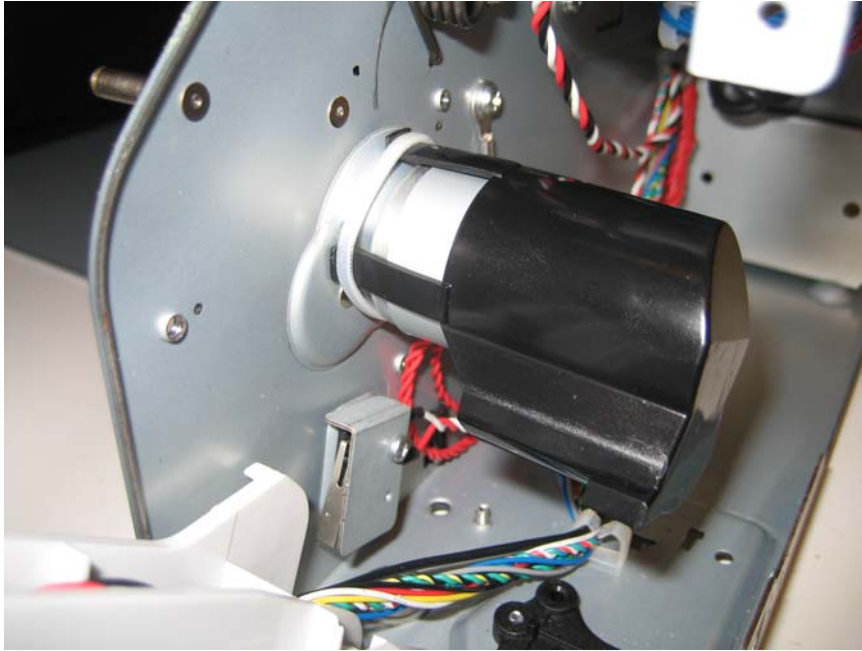

Multipurpose feeder (MPF)/duplex motor cable removal

1. Remove the multipurpose feeder/duplex motor. See **“Multipurpose feeder (MPF)/duplex motor cable removal” on page 4-114.**
2. Disconnect the connector from JDX1 (A) on the system board.

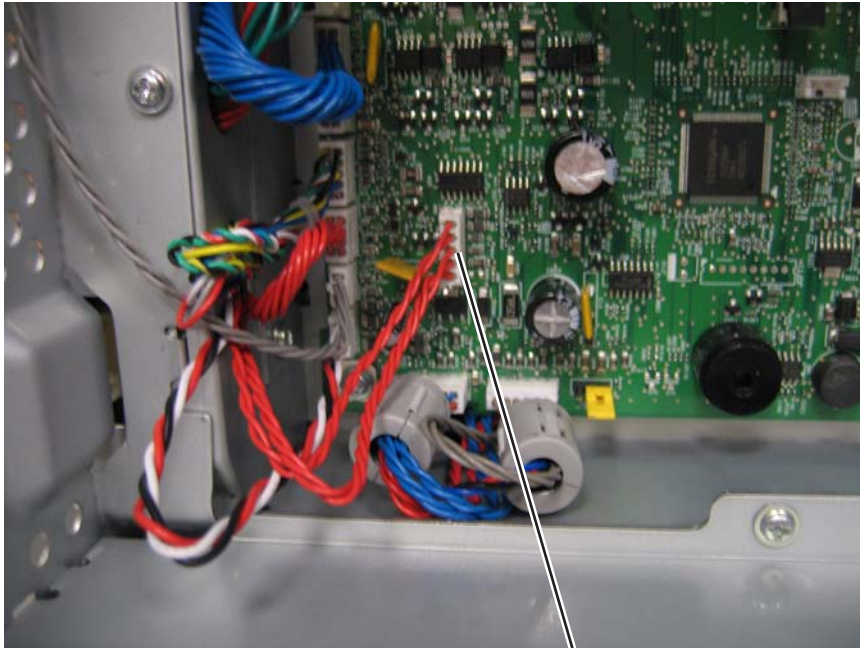

A

3. Remove the cable from the cable retainers (B).

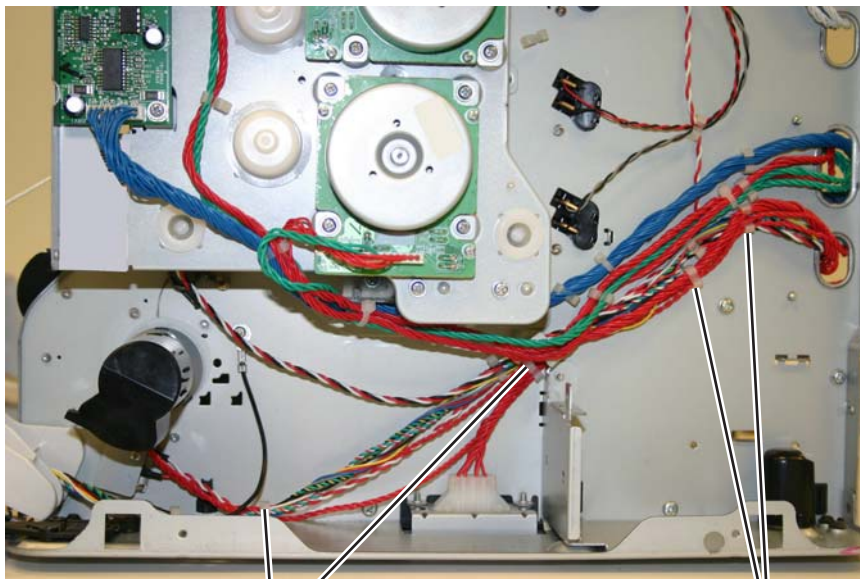

B

B

Option cable removal

1. Remove the LVPS. See **“Low-voltage power supply (LVPS) removal”** on page 4-104.
2. Disconnect the cable connector at JOPT2 (A) on the system board.

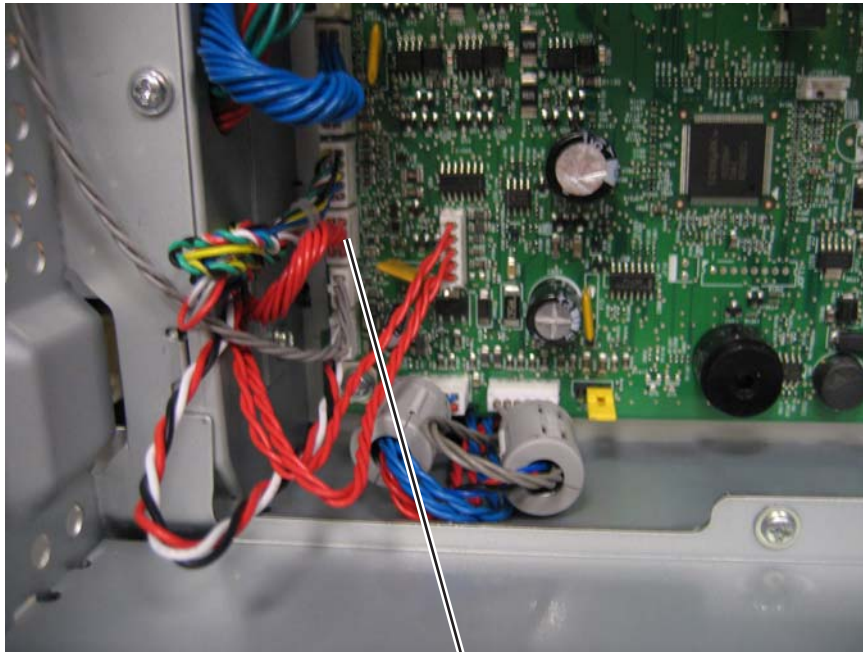

A

3. Replace the rear frame cover to protect the system board.
4. Position the printer on its back
5. Remove the two screws (B).

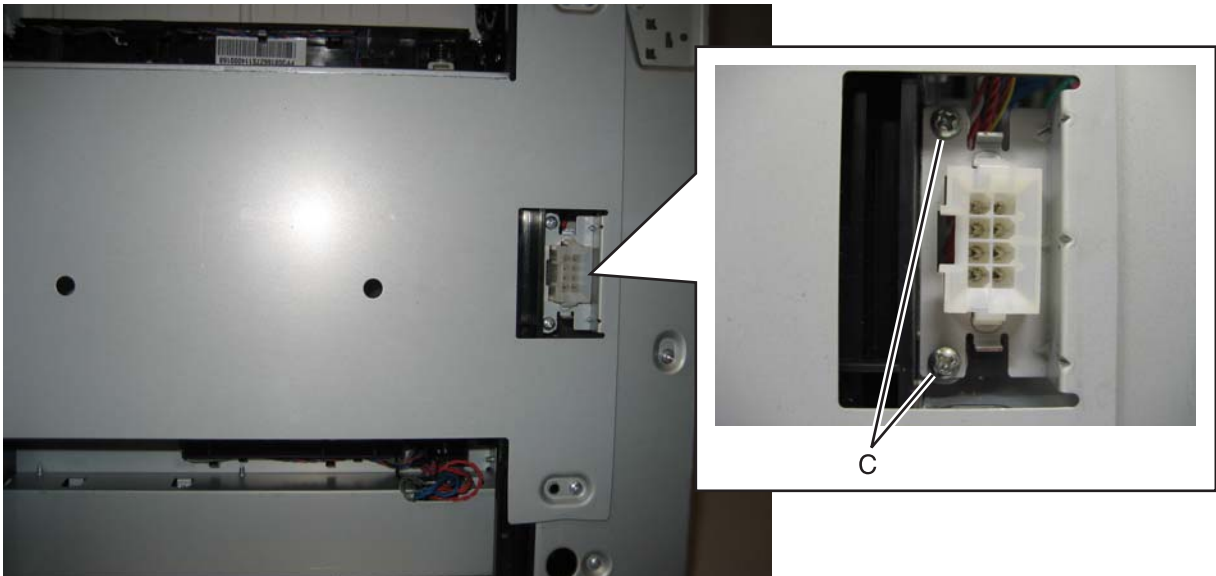

C

6. Press the tabs together to remove the option cable connector.
Note: Be sure to note the cable routing for reinstallation.

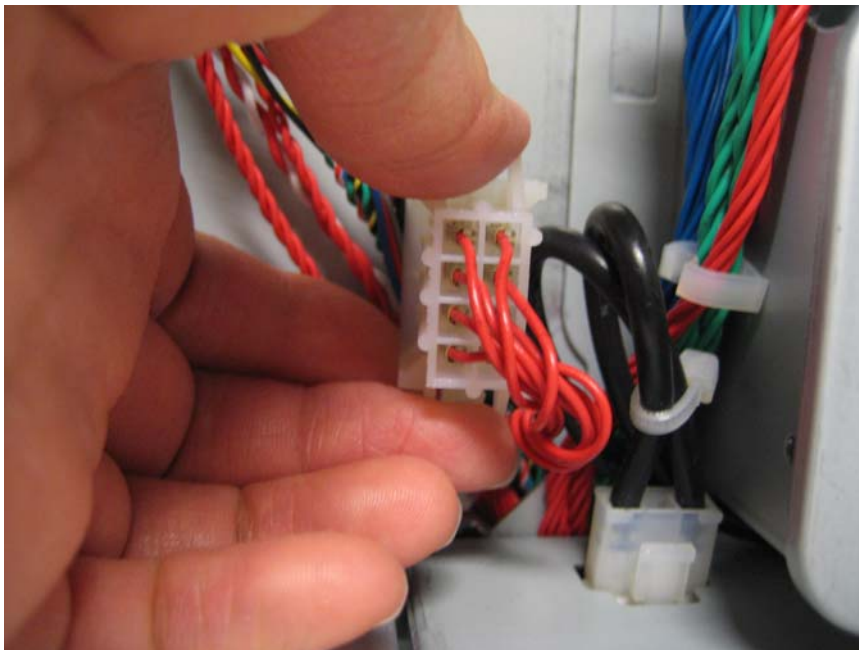

Paper pick mechanism assembly removal

See for the part number.

1. Remove the paper tray.
2. Remove the rear frame cover. See **“Rear frame cover removal” on page 4-38.**
3. Disconnect the connector in JFDPCK1 (A) and JTRAY1 (B) on the system board.
4. Open the latch (C) to remove the toroids from the cables.
5. Push the cables through the hole in the frame below the two connectors.

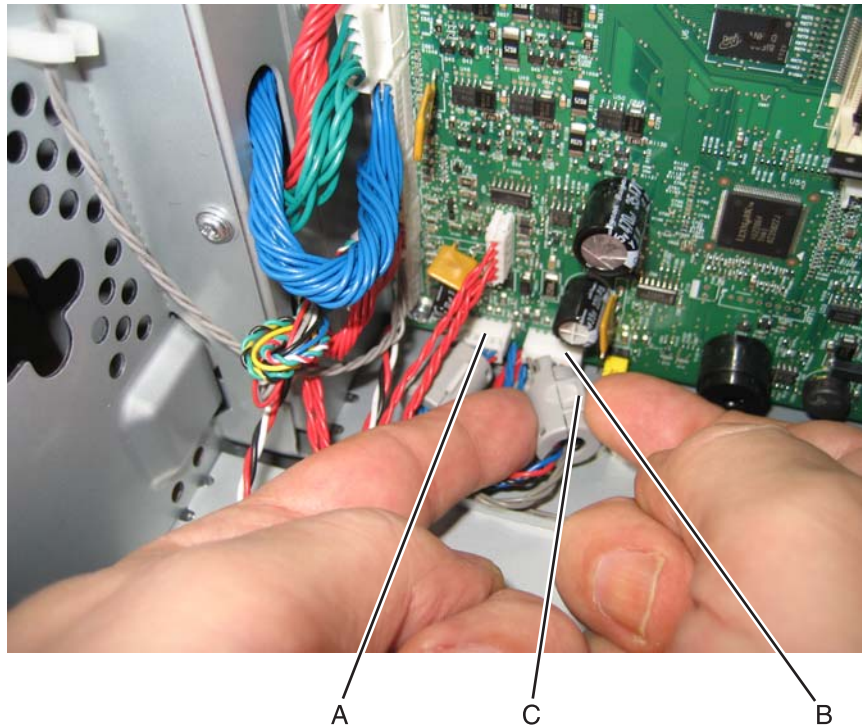

6. Open the front access cover.
7. Disconnect the transfer module cable (D).
8. Press the two tabs (E) to release the front access cover assembly.
9. Press the two tabs (F) on either side of the transfer module, and lift out the transfer module.

Note: Leave the photoconductor units on the transport belt when removing.

Warning: To avoid damaging the photoconductor drum, place the transfer module with the photoconductor units on a clean surface. Never expose the photoconductor units to light for a prolonged period of time. Place a clean, dry cloth over the transfer module and photoconductor units until they are required. Lower the front access door cover.

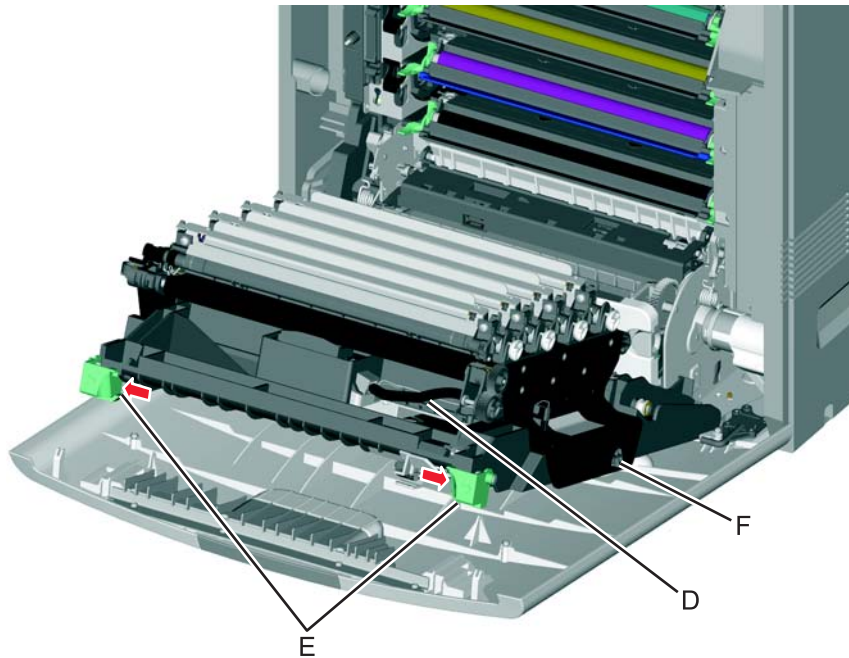

10. Remove the toner cartridges.

11. Remove the four screws (G) from the bottom pan.

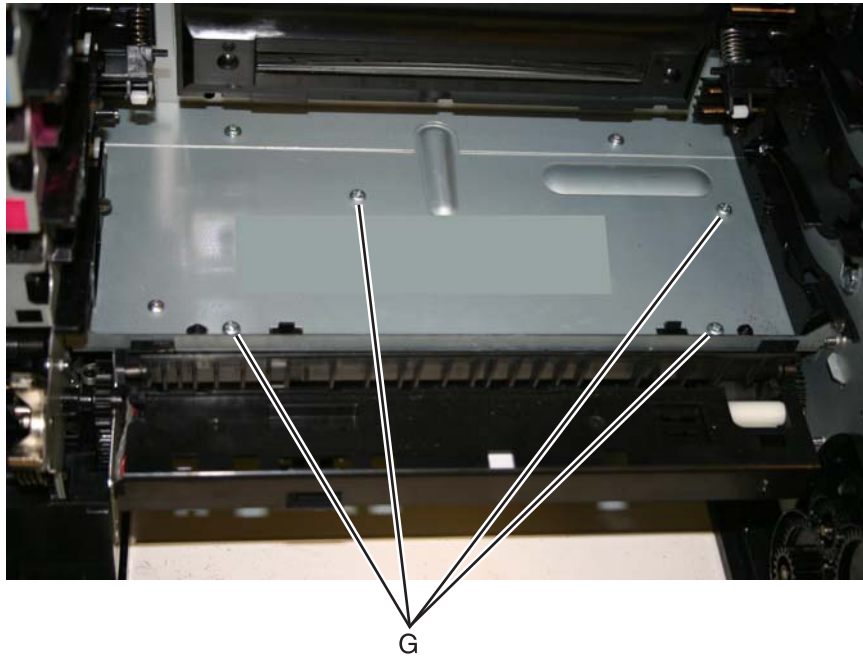

12. With one hand, disengage the gear (H), then grasp the paper pick assembly, and pull forward and downward to disengage the assembly until the front (J) and rear locking tabs release (not visible).

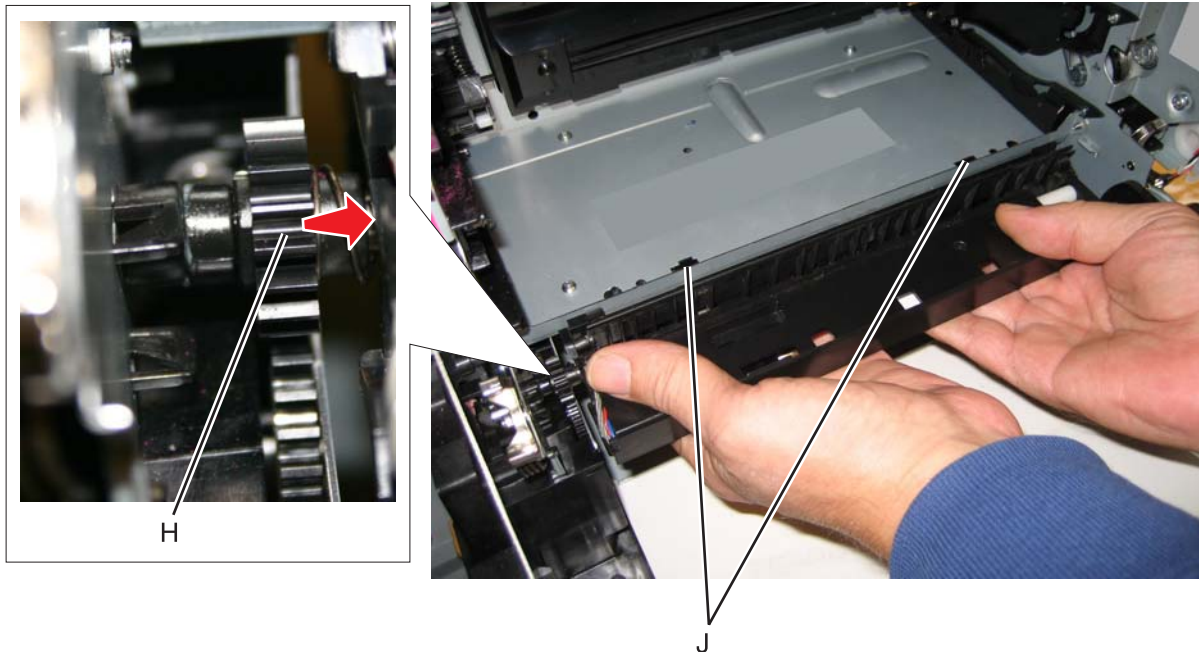

13. Lower the paper pick mechanism, and remove through the front of the printer.
Note: Make sure the JTRAY1 and JTRAY2 connectors do not bind when passing through the frame access hole.

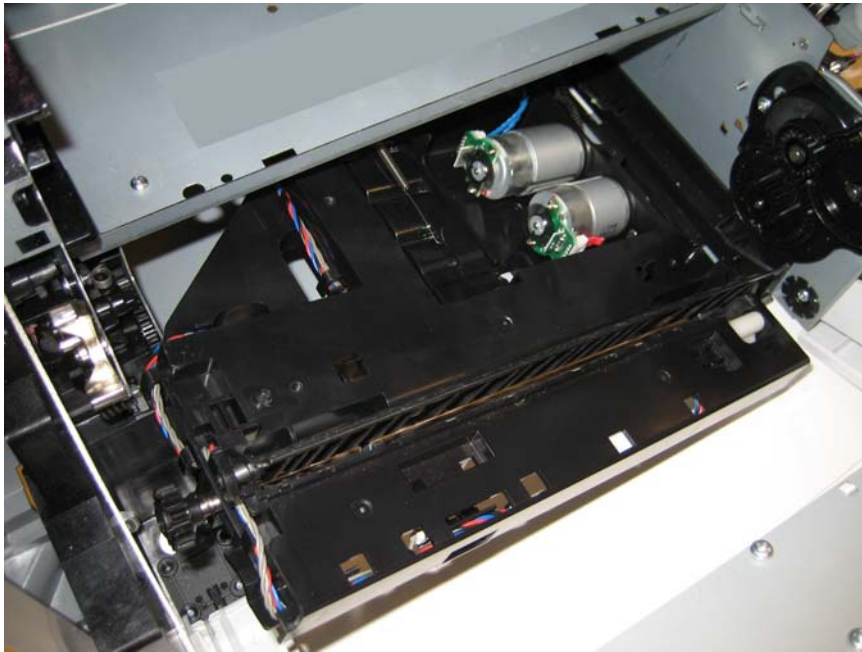

Installation notes:

1. Remove the waste toner assembly. See **“Waste toner assembly removal”** on page 4-186.
2. Replace the rear frame cover to protect the system board.
3. Slide the scanner lock to the forward position to lock the flatbed CCD carrier module in the home position.



4. Tape the ADF (scanner) cover to the flatbed scanner.



5. Turn the printer on its back.
6. Slide the paper pick assembly toward the back of the printer, and down to engage the tabs (A).
7. Slide the tabs (A), and engage the gear (B).

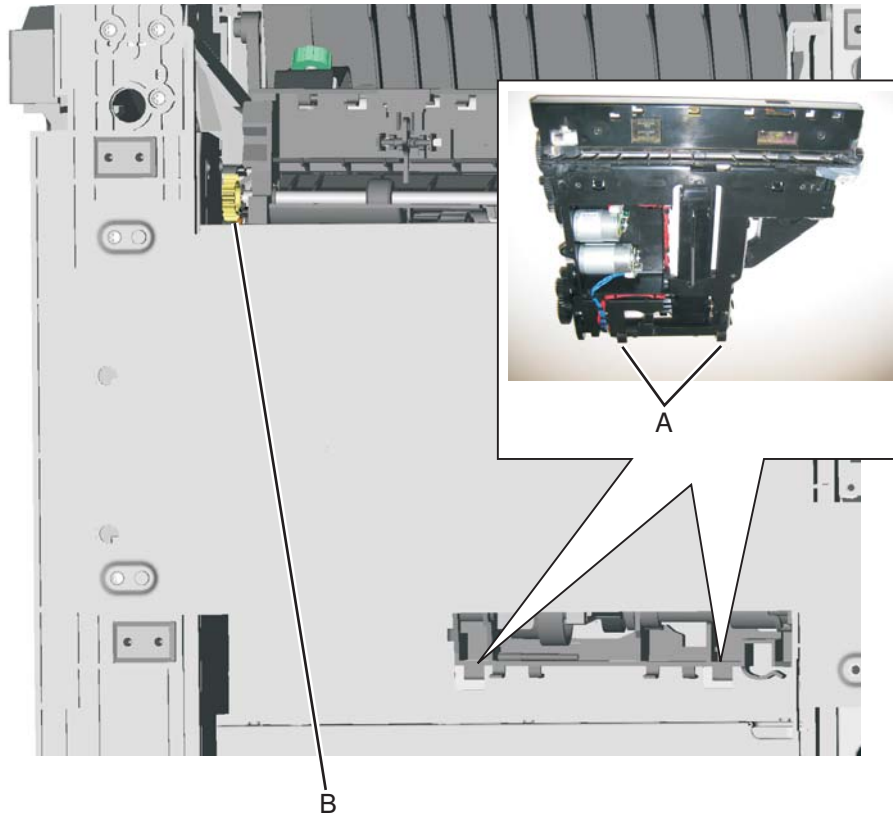

8. Reach into the printer, and replace the front right screw (C) to secure the paper pick assembly.
9. Set the printer upright.

10. Secure the remaining three screws (D).

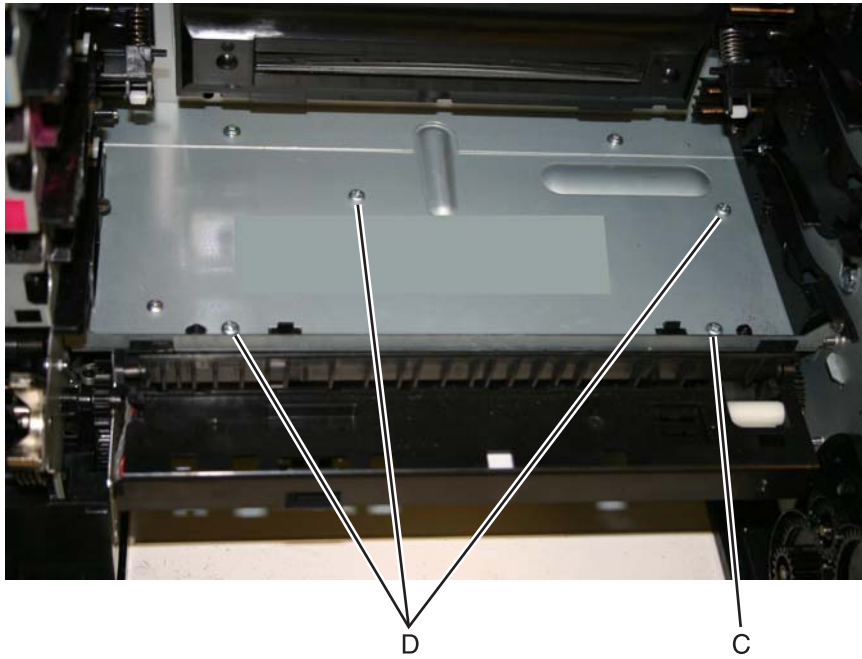

11. Remove the rear frame cover.
12. Route the cables through the hole in the frame, and connect them to JFDPCK1 (E) and JTRAY1 (F).

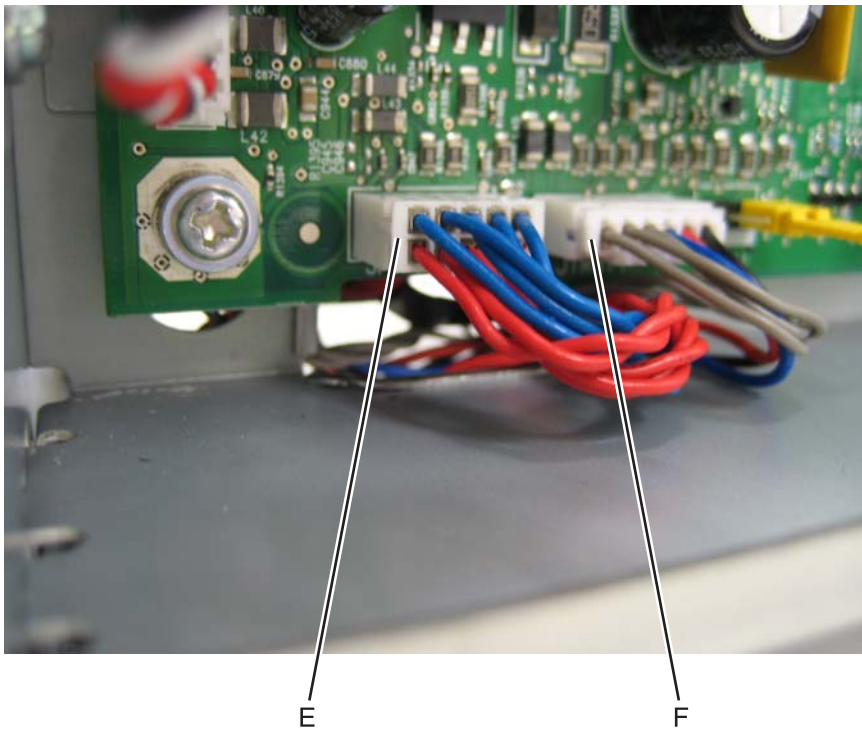

- 13.** Reattach the toroids (G) to the cables.

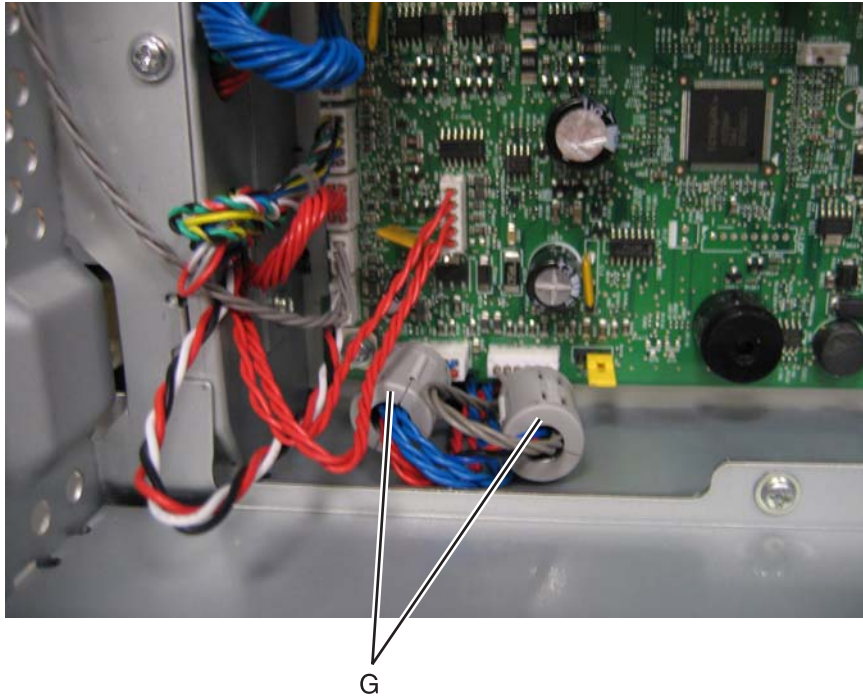

- 14.** Replace the rear frame cover.
15. Replace the waste toner assembly.
16. Replace the toner cartridges.
17. Replace the transfer module with the photoconductor units.
18. Close the front access cover.
19. Replace the paper tray.
20. Open the ADF (scanner) cover and slide the scanner lock to the open position.

Photoconductor unit removal

Not a FRU

Warning: To avoid damaging the photoconductor drum, hold the photoconductor units by their handle and place the photoconductor units on a clean surface. See **“Handling the photoconductor unit”** on **page 4-2** for additional information.

1. Open the front access door.
2. Lift the right end handle (A) of the photoconductor unit, releasing from the mount.
3. Lift the unit up and away from the left side of printer, ensuring the left end of the photoconductor is released from the holding pin (B).

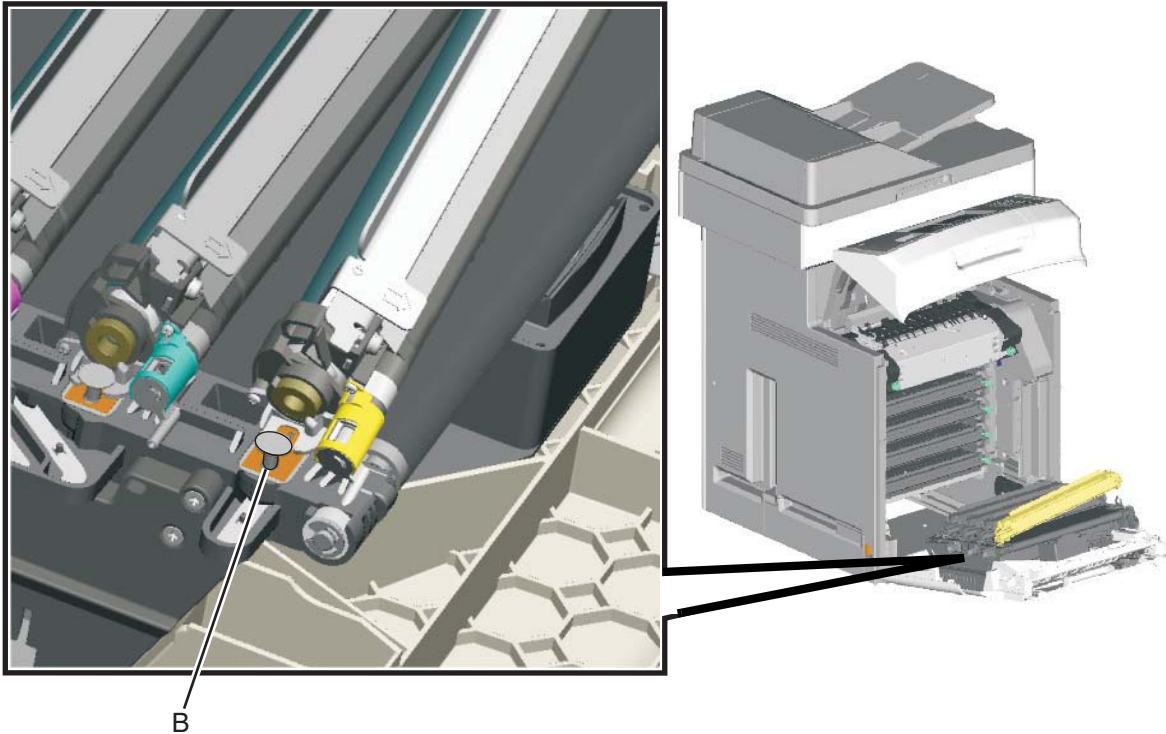

Installation note: If a new photoconductor unit is installed, reset the life count value in the printer memory.

- If a message appears on the operator panel:
 1. When 84 *<color>* PC Unit Life Warning or 84 Replace *<color>* PC Unit appears, touch **Supply Replaced**.
Replace Supply displays.
 2. Touch **Cyan PC Unit**, **Magenta PC Unit**, **Yellow PC Unit**, or **Black PC Unit** based on the photoconductor unit that was just replaced.
<color> PC Unit Replaced displays.
 3. Touch **Yes** to clear the message.
- If no message appears:
 1. Press **Menu** ().
 2. Touch **Supplies Menu**.
 3. Touch **Replace Supply**.
 4. Touch **Cyan PC Unit**, **Magenta PC Unit**, **Yellow PC Unit**, or **Black PC Unit** based on the photoconductor unit that was just replaced.
<color> PC Unit Replaced displays.
Touch **Yes**.

Pick tires removal and replacement

See for the part number.

The autocompensator pick roll tires are located in the base printer. There are also tires in all input options. If you have additional input options, and you are having problems with media picking, replace these tires also. Always replace the pick tires in pairs. The tires come in a package of two.

Warning: Remove only the rubber tires and not the pick tire assembly to avoid losing small parts.

1. Remove the paper tray.
2. Pull the paper pick arm (A) down.

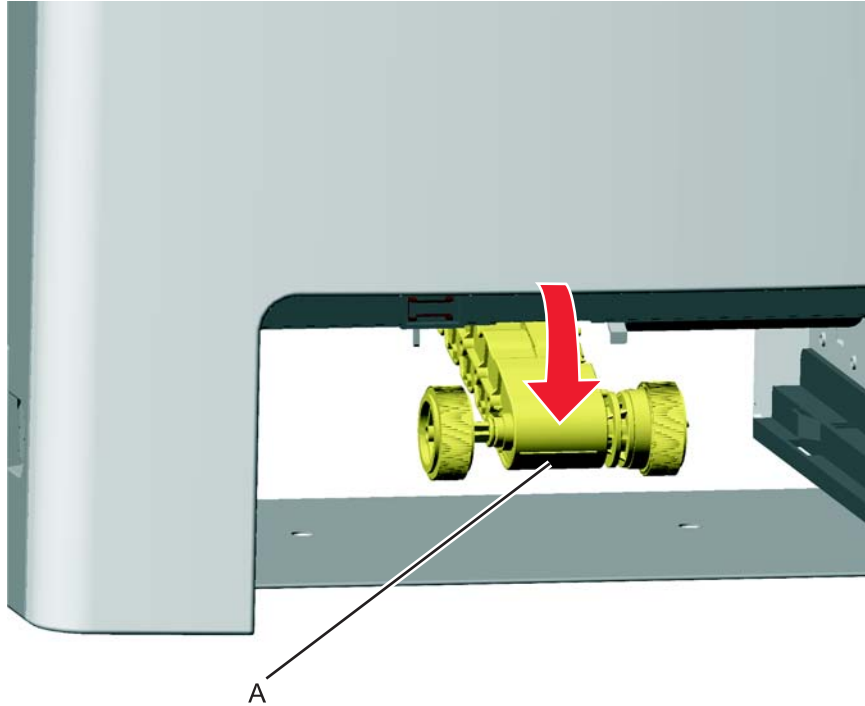

3. Remove the pick tire (B) from the pick tire assembly (C). Repeat for the other pick tire (D).

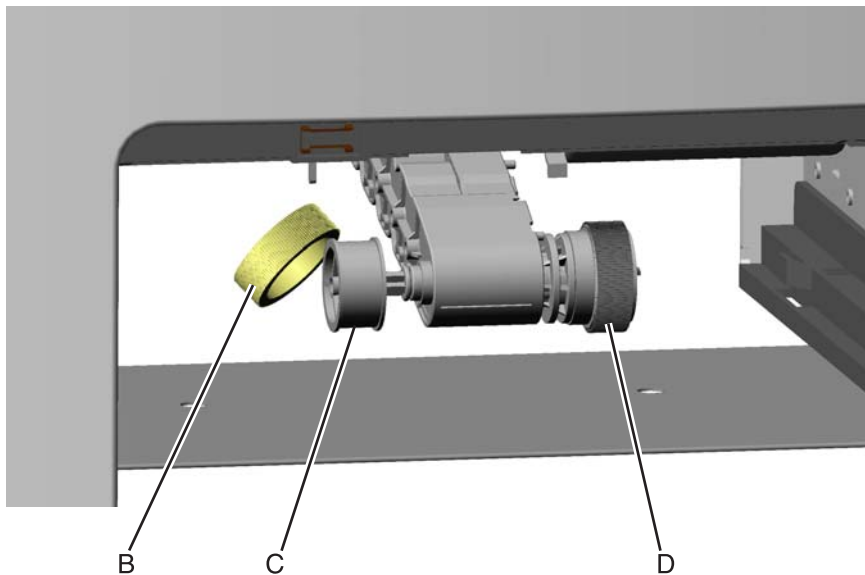

Installation notes: Install the new rubber tires with the surface texture turning in the direction as shown.

Note: Feel the rubber surface to verify it turns properly in the direction shown.

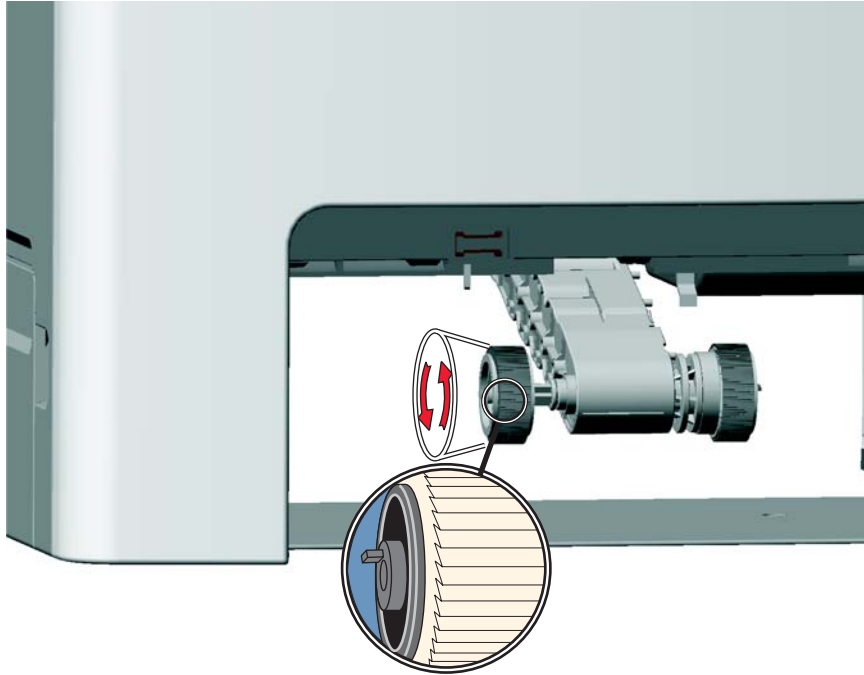

Printer pad removal

1. Slide the corner of the printer containing the damaged pad over the corner of the table.
2. Remove the side cover that corresponds to the damaged pad so you can see if the pad fully seats in the installation holes.

3. Pull the pad (A) from the bottom of the printer. There are two rubber connectors.

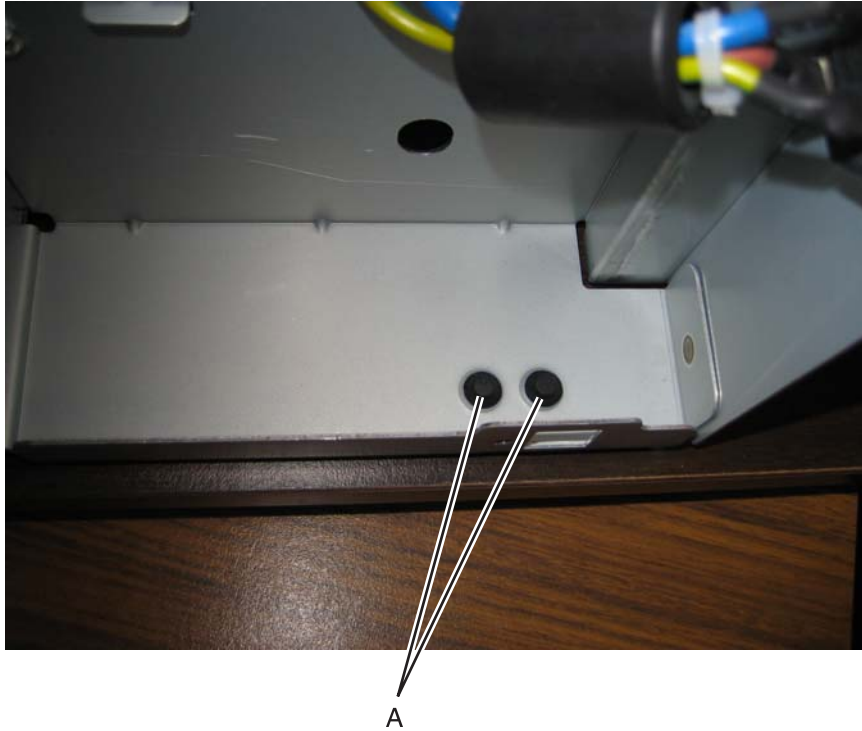

Installation note: Verify that the pad fully seats in the installation holes.

Printhead removal, installation, and adjustment

See “**Printhead assembly**” on page 7-9 for the part number.

Service tip—Testing the new printhead

See “**Printhead verification**” on page 3-52 for quick way to verify that the NVRAM on a printhead is good before you install the printhead.

Printhead removal

1. Turn the printer off.
2. Disconnect the power cord from the electrical outlet and from the printer.
3. Remove the paper tray.
4. Open the top access door.
5. Open the front access door.
6. Remove the fuser.

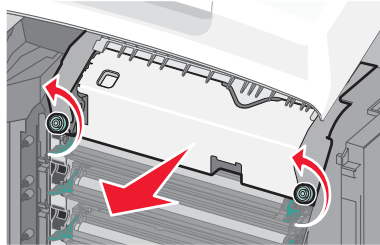

7. Remove the transfer module and photoconductor units.
 - a. Disconnect the transfer module cable (A).
 - b. Press the two tabs (B) to release the front access cover assembly.
 - c. Press the two tabs (C) on either side of the transfer module, and lift out the transfer module.

Note: Leave the photoconductor units on the transport belt when removing.

Warning: To avoid damaging the photoconductor drum, place the transfer module with the photoconductor units on a clean surface. Never expose the photoconductor units to light for a prolonged

period of time. You can place a clean, dry cloth over the transfer module and photoconductor units until they are required.

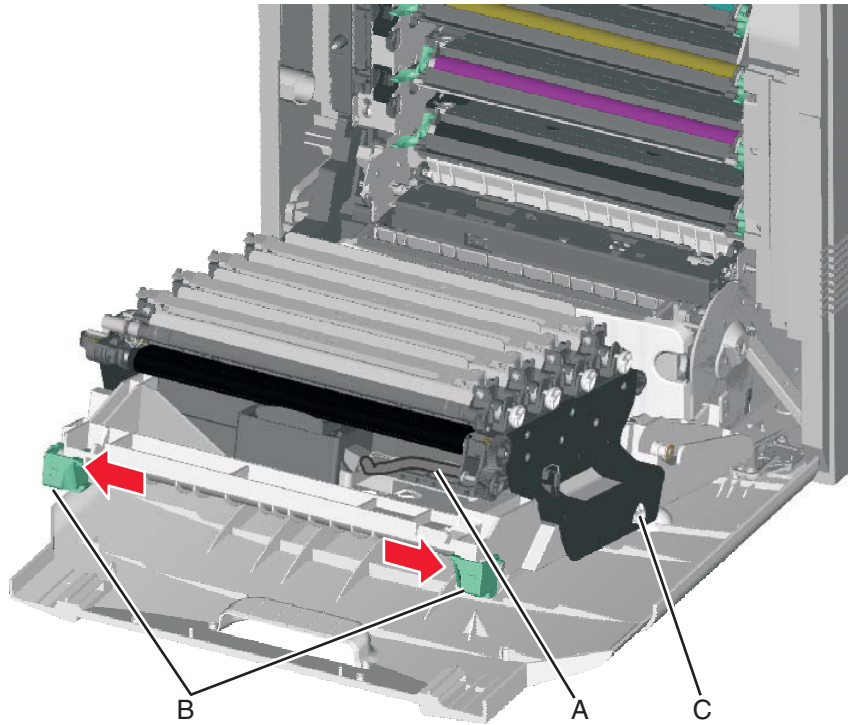

8. Remove all of the toner cartridges.
 - a. Remove the four screws (D).

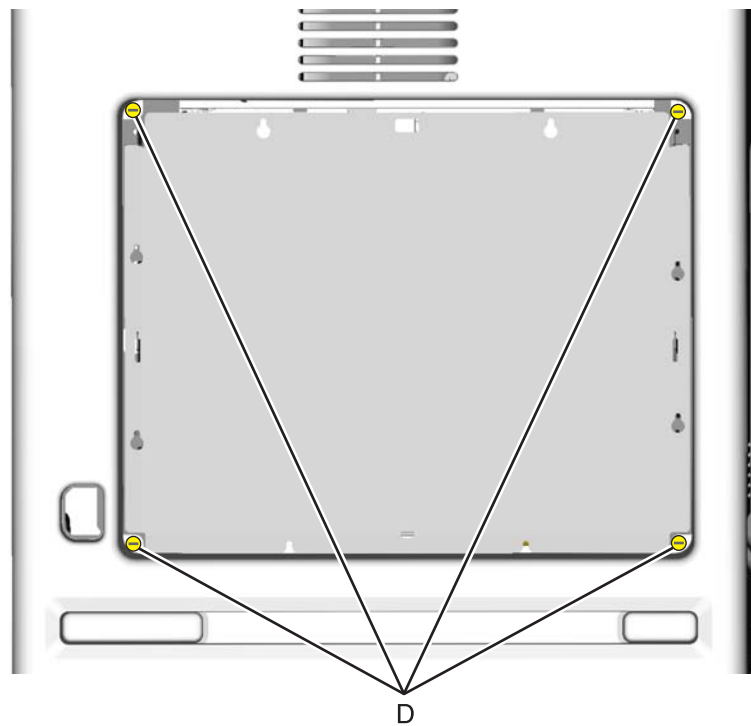

- b. Lift the rear cover and remove it.

9. Remove the rear frame cover.
 - a. Loosen the eight screws (E).
 - b. Lift the rear frame cover, and remove.

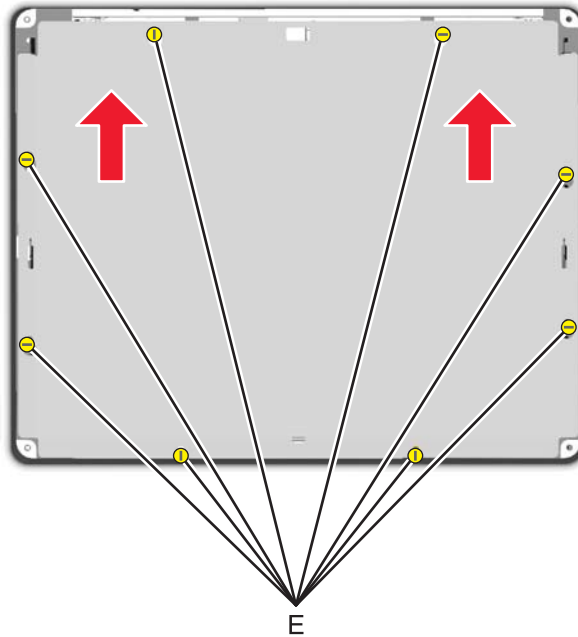

10. Remove the right cover. See **“Right cover removal” on page 4-39.**
11. Remove the left cover with the left door cover attached. See **“Left cover removal” on page 4-23.**
12. Remove the system board support shield. See **“System board support shield removal” on page 4-154.**
13. Remove the printhead.
 - a. Remove the printhead mounting screws (F).

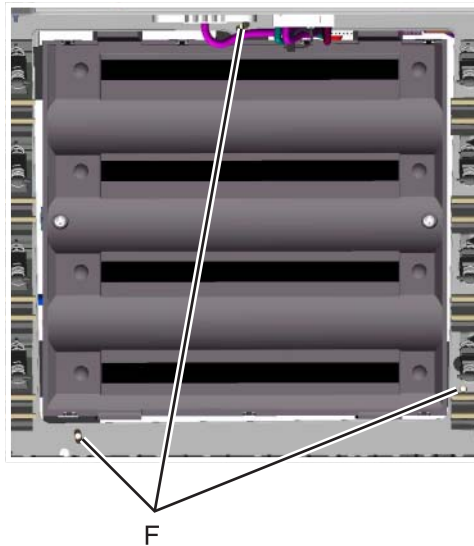

- b. While holding the printhead in place, loosen the printhead alignment screw (G) until the printhead comes out easily.

Warning: Secure the printhead when loosening the printhead alignment screw. Failure to do this allows the printhead to fall out of the printer, potentially damaging the printhead.

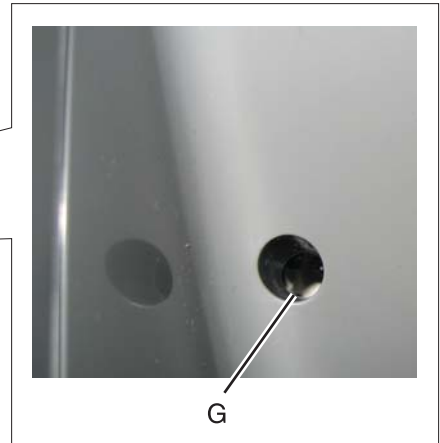

Install the printhead and replace parts

Warning:

- When reinstalling the printhead, it is important to keep in mind that the printhead mounting screws should be **initially tightened just enough to hold the printhead in the printer**. The printer parts are installed with the printhead mounting screws loose so you can print the pages that will be used to align the black plane to the printer frame. This also allows the black skew adjustment with the printhead alignment screw.
 - Once the black skew is aligned, the mounting screws will be fully tightened, and the next steps of alignment can be completed.
1. When installing the printhead, visually center the printhead and center the hole in the frame (A).

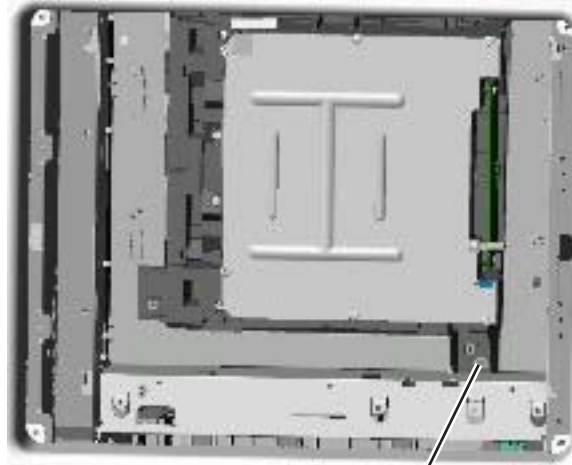

A

2. Loosely attach the printhead mounting screws (B).

Warning: Do not fully tighten the printhead mounting screws until skew has been adjusted.

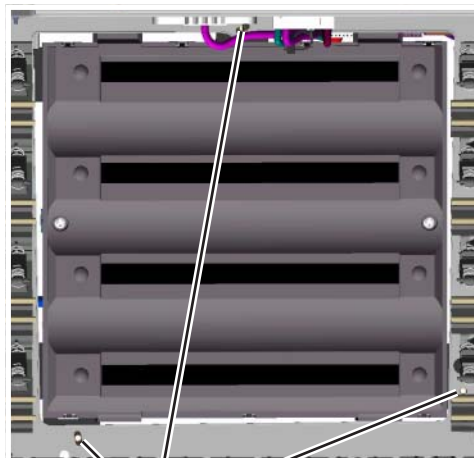

B

3. Lightly tighten the alignment screw (C).



4. Feed the ground cable through the hole in bottom left side of the frame.

5. Replace the system board support shield.
- Loosely attach the two mounting screws (D2).
 - Set the system board shield in place.
Note: Check that the ribbon cables do not rub against the edges of the frame.
 - Replace the remaining system board shield screws (D) in the following order:
 - Replace the five screws (D1) from the inner right side of the support shield.
 - Replace the two mounting screws (D2) to the top of the support shield.
 - Replace the three screws (D3) from the bottom of the support shield.
 - Replace the five mounting screws (D4) to the outer left side of the printer.**Note:** Be sure to connect the printhead ground cable (D5) to the fourth screw from the top.

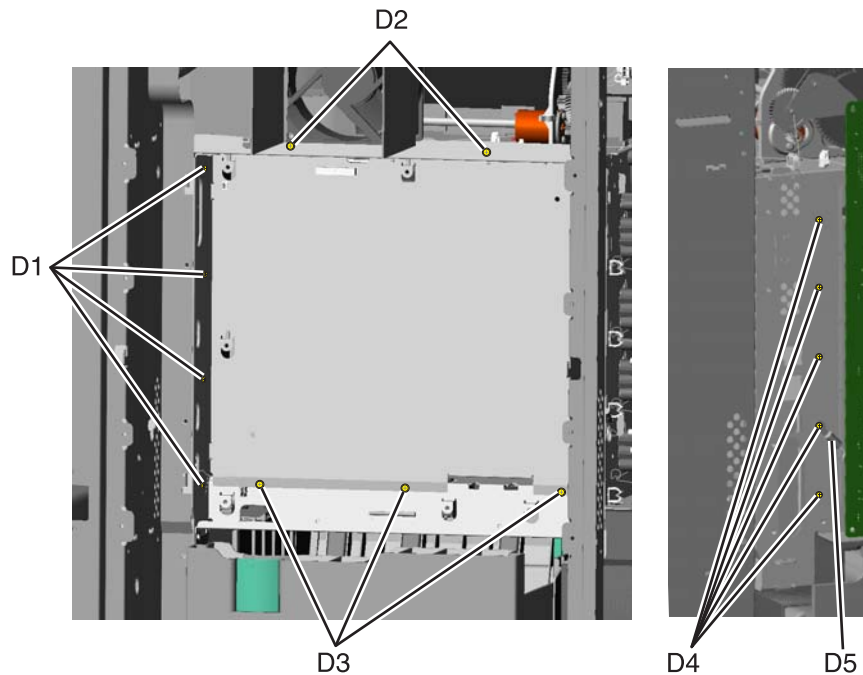

6. Replace the system board.

a. Place the system board in position.

Note: Check that the mirror motor cable, printhead, and UICC cables do not rub against the edges of the frame.

b. Replace the nine screws (E) in the system board in the following order:

- Loosely attach the four corners (E1) in a clockwise order, beginning with the left top center.
- Replace the USB connector screw (E2).
- Replace the top center, right center side, and left center side (E3)
- Tighten the top left corner and the top right corner.
- Replace the two screws on the center bottom (E4)
- Tighten the bottom right and the bottom left corners (E1).

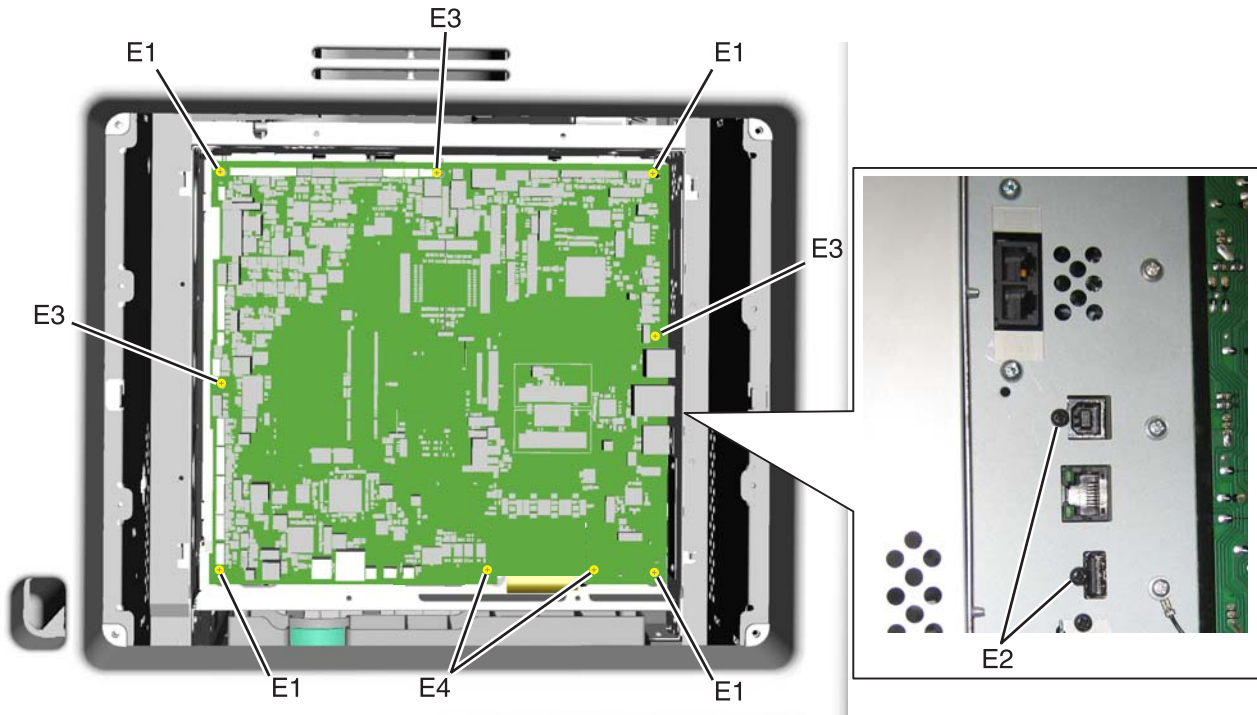

c. Route the cables through the access holes on the right side of the printer.

- d. Replace the ground strap (F) on the screw (G), and tighten the screw.
- e. Replace the two screws (H) for the hard disk shield.

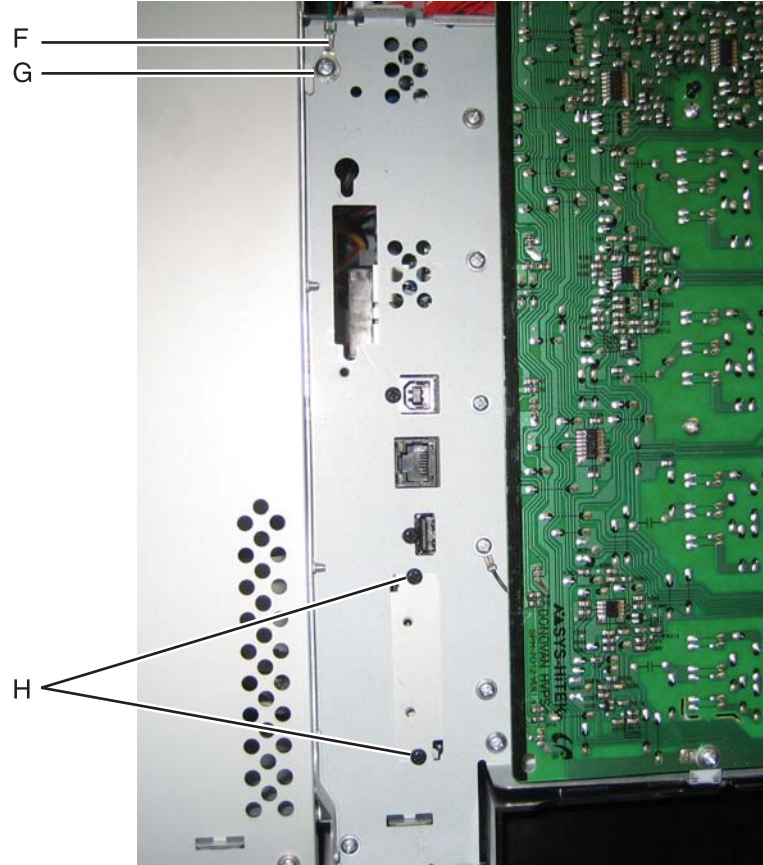

f. Reconnect all the connectors to the system board. Use the diagram below for a guideline.

Warning: Be careful reconnecting the printhead ribbon cable (J) and the UICC cable (K). Ribbon cables can be damaged easily and should be handled carefully.



- g. Replace the fax modem card and/or the hard disk, if appropriate.
- 7. Replace the LVPS.
 - a. Install the LVPS.
 - b. Replace the five LVPS mounting screws.
 - c. Reconnect the AC LVPS cable to the LVPS.
 - d. Reconnect the AC power cable to the LVPS.
 - e. Reconnect the AC LVPS cable to the JLVPS1 connector on the system board.
- 8. Replace the right cover.
 - a. Slide the right cover up until it locks into position.
 - b. Replace the three screws.
- 9. Replace the left cover.
 - a. Place the printer on the table with the left side edge hanging over slightly.
 - b. Slide the cover up until it locks into position.
 - c. Replace the three screws.
- 10. Replace the rear frame cover.
 - a. Replace the rear frame cover.
 - b. Tighten the eight screws.
- 11. Replace the rear cover.
 - a. Place the two top tabs in the slots.
 - b. Replace the four screws.
- 12. Reinstall the transfer module with the photoconductor units still attached.
- 13. Reconnect the transfer module cable.
- 14. Replace the toner cartridges.
- 15. Replace the fuser.
- 16. Close the front access door.
- 17. Close the top access door.
- 18. Replace the paper tray.













Printhead alignment

Note: The printhead mounting screws should be initially tightened **just enough to hold the printhead in the printer.**

There is one printhead that houses the four color planes. The black plane is aligned to the printer, and the color planes are internally aligned to black. Electrical alignment is done to fine tune the alignment of the color planes to the black plane after the printhead is installed and black skew is adjusted using the alignment screw.

Skew (black)

1. Connect the electrical cord into the printer.
2. Connect the electrical cord into the outlet.
3. Set the skew for black.
 - a. Open the top access cover.
 - b. Open the front access cover.
 - c. Enter Diagnostic mode (turn off the printer, press and hold 3 and 6, turn on the printer, and release the buttons when the progress bar appears).
 - d. Select **Registration**.

Registration			
Top Margin		9	
Bottom Margin		-1	
Left Margin		-1	
Right Margin		0	
Skew		0	
Quick Test			
			

- e. Adjust the value beside Skew to zero with the left and right arrows, and touch **Submit**.

f. Touch **Quick Test**. A page similar to this one prints:

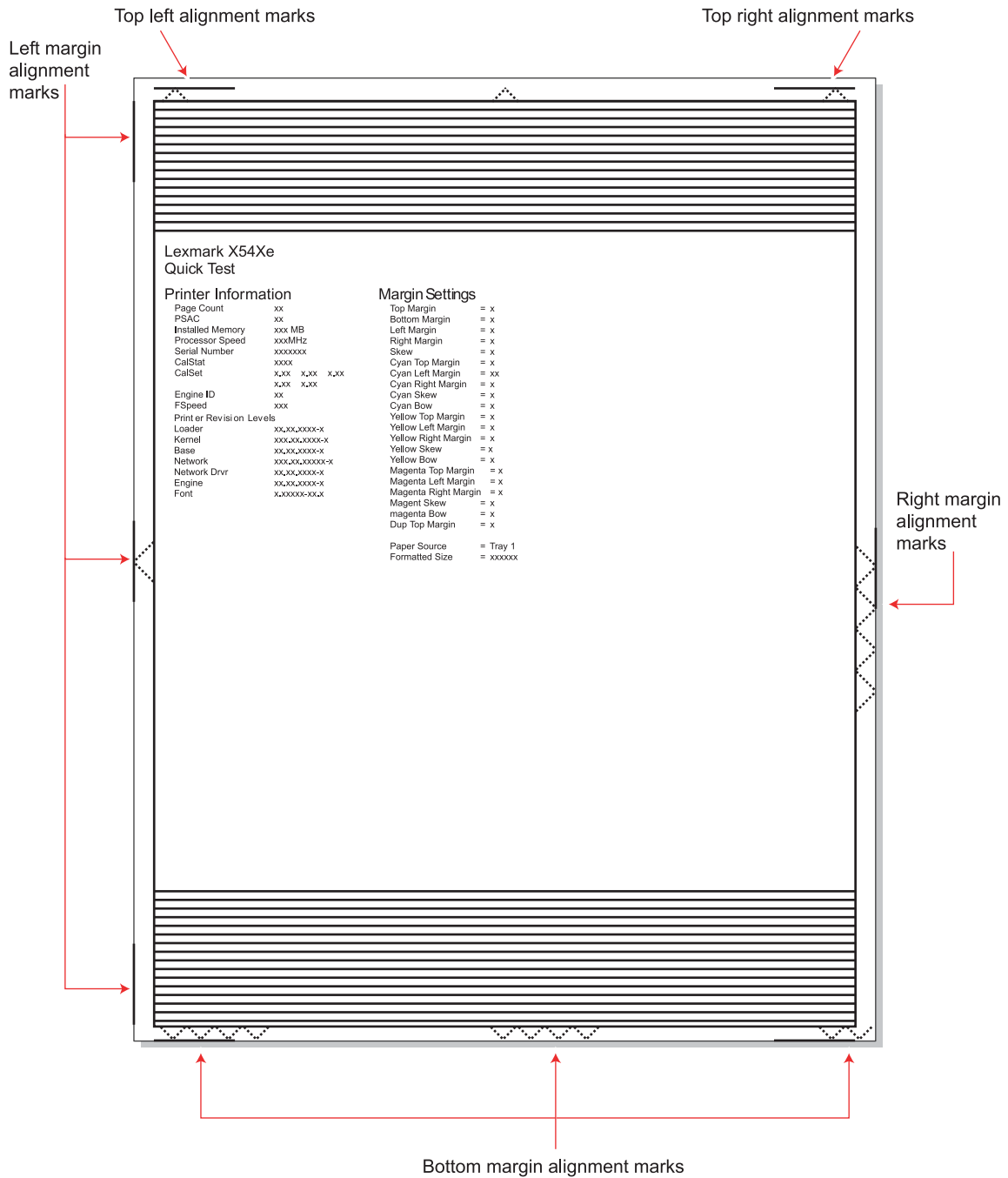

- g. Adjust the printhead alignment screw (A) to adjust the skew and straighten the image on the printout.

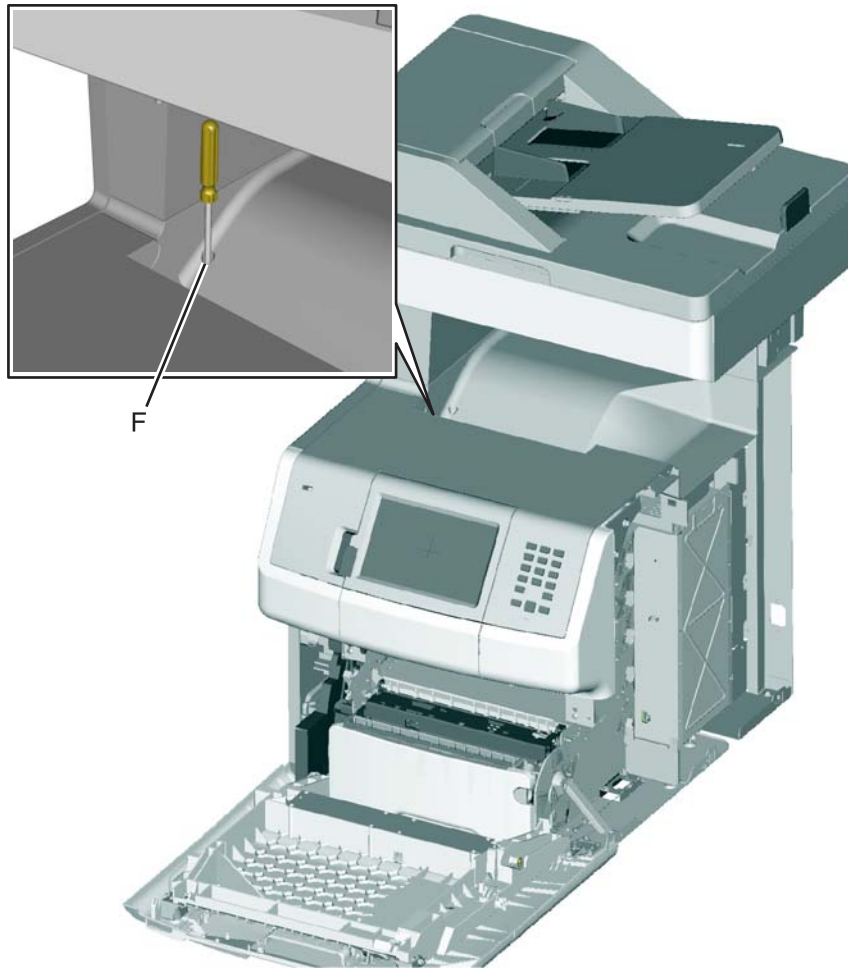

If the top right alignment marks are lower than the top left alignment marks, rotate the alignment screw counterclockwise a full revolution, and print the Quick Test page. Repeat adjusting the screw and printing the Quick Test page until the top alignment marks are the same distance from the top of the media.

Note: One rotation of the printhead alignment screw equals approximately 0.5 millimeter movement of the top edge print alignment marks.

- h. When the top right and top left alignment marks are both showing and are even on the page, the skew is aligned.

Straight

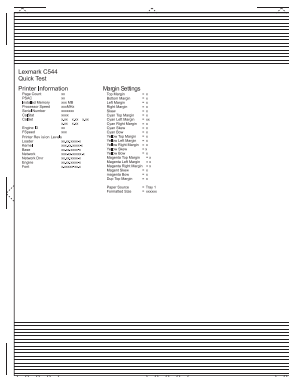

Skewed

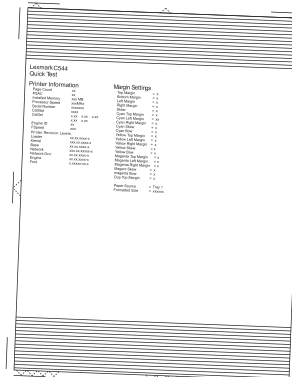

4. Tighten the printhead mounting screws.
 - a. Turn off the printer.
 - b. Disconnect the power cord from the electrical outlet.
 - c. Disconnect the transfer module cable.
 - d. Press the two tabs on either side of the transfer module, and lift out the transfer module with the photoconductor units in place.
 - e. Remove all of the toner cartridges.
 - f. Tighten the printhead mounting screws in the following order: G1, G2, and G3.

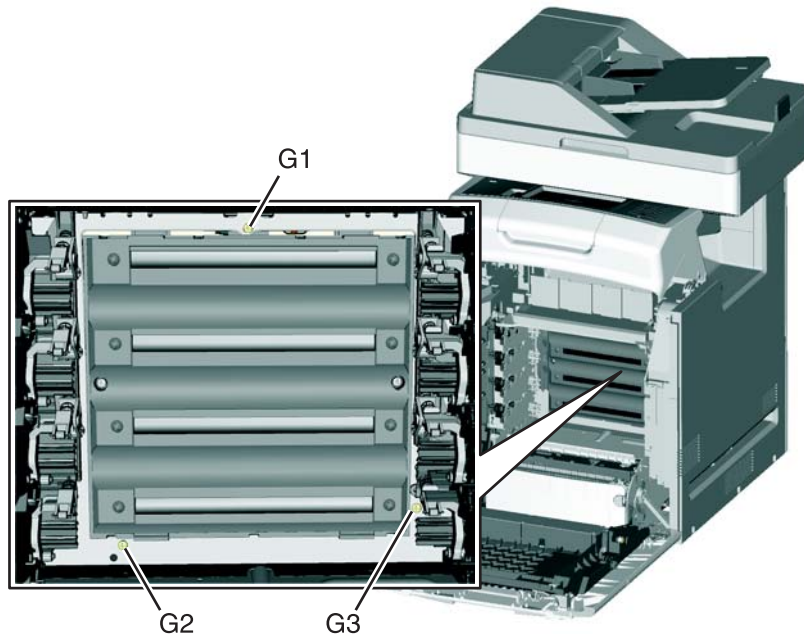

5. Replace the toner cartridges.
6. Reinstall the transfer module and the photoconductor units.
7. Connect the transfer module cable.

Registration (black)

Top Margin

1. Reconnect the power cord to the electrical outlet, but do not turn on the printer yet.
2. Enter Diagnostic mode (press and hold **3** and **6**, turn on the printer, and release the buttons when the progress bar appears).
3. Touch **Registration**.

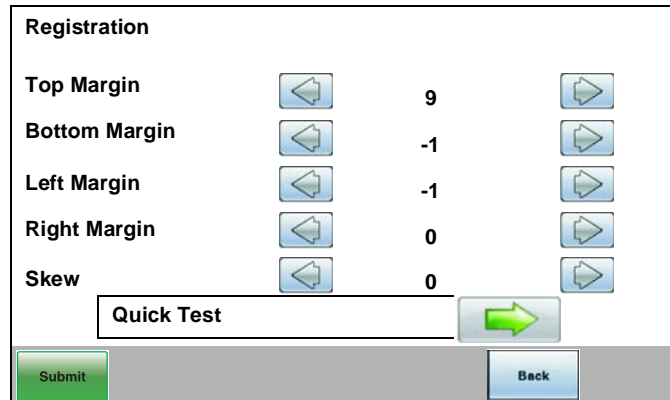

4. Touch **Quick Test**.

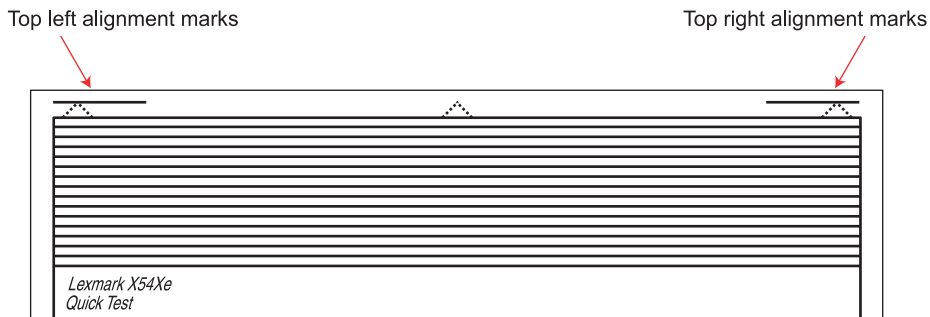

5. Beside **Top Margin**, use the arrows to change the values.
 - a. Adjust the values until both top alignment marks are on the top edge of the print.
 - The right arrow increases the value and moves the top alignment marks down the page.
 - The left arrow decreases the value and moves the top alignment marks up the page.
 - b. Touch **Submit** to save the value, and then touch **Registration** to return to the Registration menu.
6. Print the Quick Test page, and check the top alignment marks. Repeat adjustment of the top margin and printing of the Quick Test page until top margin is set.

Bottom Margin

1. Adjust the bottom margin until the points of the bottom margin alignment marks are visible and touching the edge of the paper.

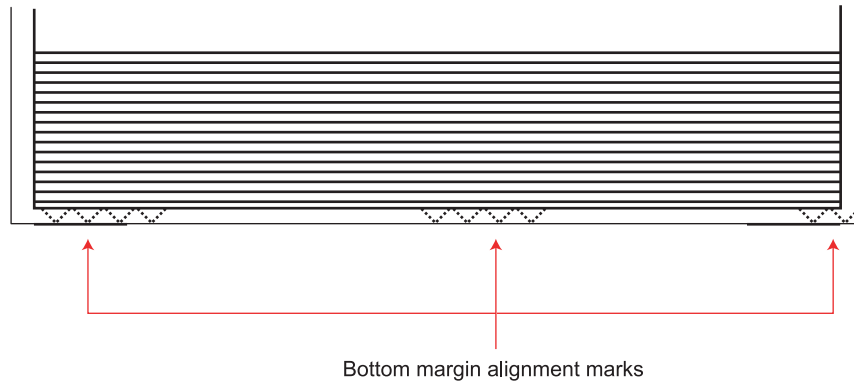

- The right arrow increases the value and moves the bottom alignment marks up the page.
 - The left arrow decreases the value and moves the bottom alignment marks down the page.
2. Touch **Submit** to save the value.
 3. Print the Quick Test page, and repeat this process until the bottom margin is adjusted.

Left Margin

1. Adjust the left margin until the points of the left alignment marks touch the edge of the page.

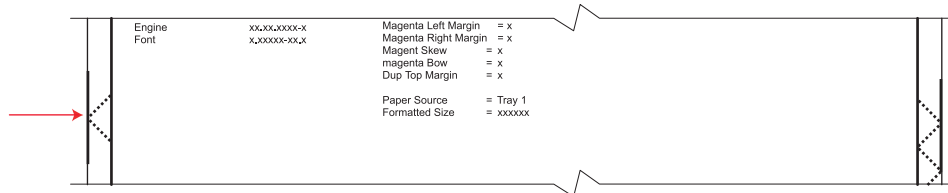

- The right arrow increases the value and moves the left side alignment marks to the right.
 - The left arrow decreases the value and moves the left side alignment marks to the left.
2. Press **Submit** to save the value.
 3. Print the Quick Test page, and check the left alignment marks each time until you are satisfied.

Right Margin

1. Adjust the right margin until the points of the left alignment marks touch the edge of the page.

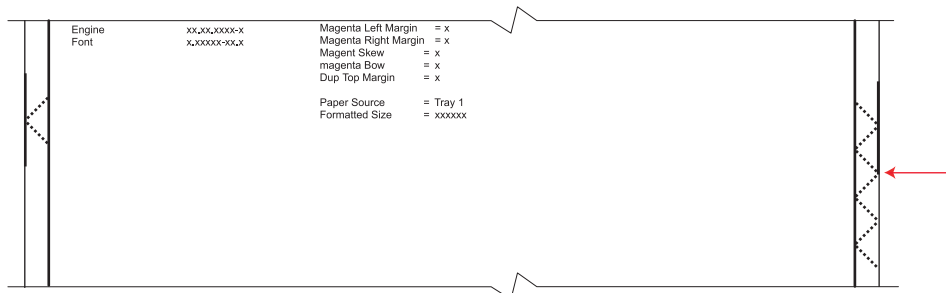

- The right arrow increases the value and moves the right side alignment marks to the left.
 - The left arrow decreases the value and moves the right side alignment marks to the right.
2. Touch **Submit** to save the value.
 3. Print the Quick Test page, and check the results. Repeat if necessary.
 4. When the registration is complete, proceed to the color alignments.

7. Determine the line under Fine Adjustment that is closest. If the value is beyond the Fine Adjustment scale, use either of the Coarse Adjustment scales.

Top (T) Coarse Adjustment

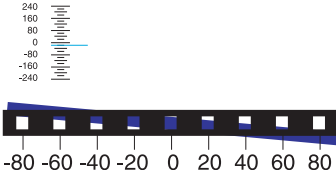

Top (T) Fine Adjustment

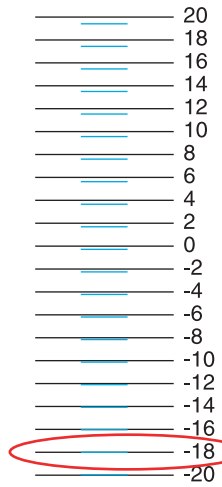

If the alignment is not close enough to use the fine adjustment, get close to the ideal value by using the coarse adjustment marks. Select the block that is most filled by the color on the left, or approximate if none of the blocks are completely filled, and enter it for the new value. Reprint the quick test page, and then use the fine adjustment.

First, locate the line of the color that you are aligning that lines up best with the scale line. In this example, it is -18. If none of the colored lines match up, use the coarse adjustment to get close, reprint this page and then use the fine adjustment.

8. Enter the number determined from the Fine Adjustment scale or the Coarse Adjustment scales on the part of the page for the "T" value. The current value is automatically entered on the sheet. At this point, it should be zero.

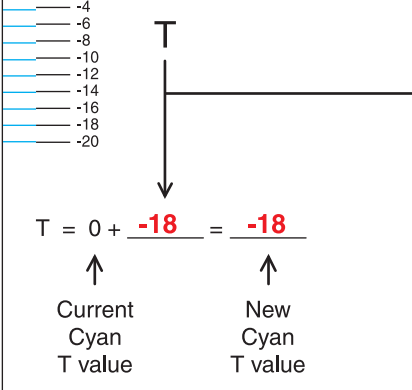

$$T = 0 + (-18) = -18$$

Current Cyan T value New Cyan T value

9. Enter the "New Cyan T value" on the operator panel using the left and right arrows, and press **Submit** to save the value.
10. Reprint the Quick Test, and evaluate whether you are at zero changes.

11. Repeat this process for skew (Z). Don't forget to subtract the T value and add the current cyan Z value to obtain the new skew (Z) value.
An example is shown below:

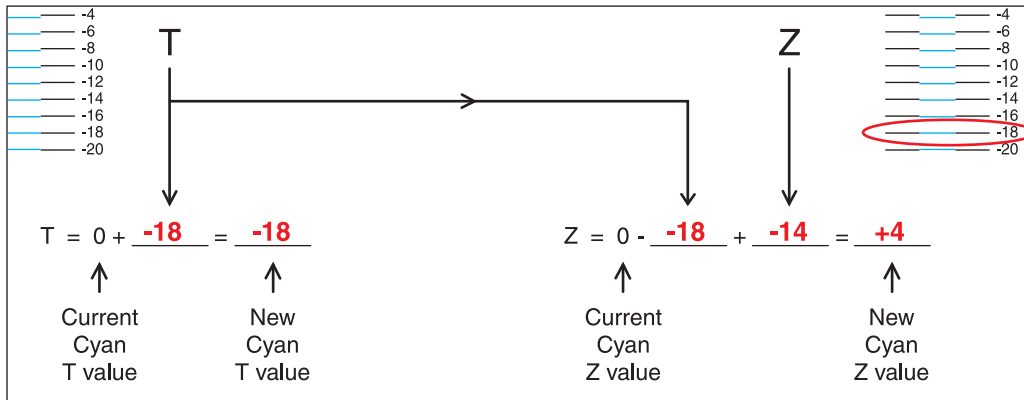

12. Continue to follow the directions on the bottom of the first page to find the Cyan Top Margin (T), the Skew (Z), and on the second page of the Quick Test page, the Left Margin (L), Right Margin (R), and Bow (P).

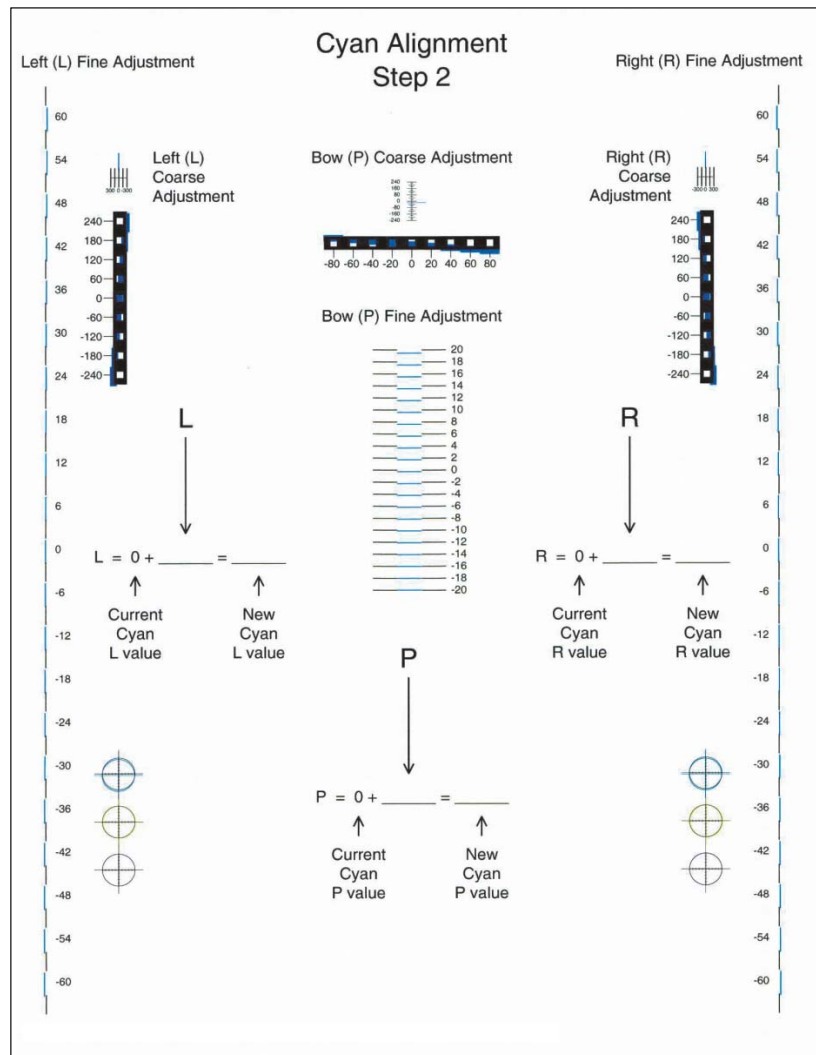

13. Repeat steps 2 through 11 for yellow and magenta.
Note: Start each color group by setting the Top Margin, Left Margin, Right Margin, Bottom Margin, Skew, and Bow to zero.

Right bellcrank assembly removal

See for the part number.

1. Remove the right cover. See **“Right cover removal”** on page 4-39.
2. Remove the C-clip (A).

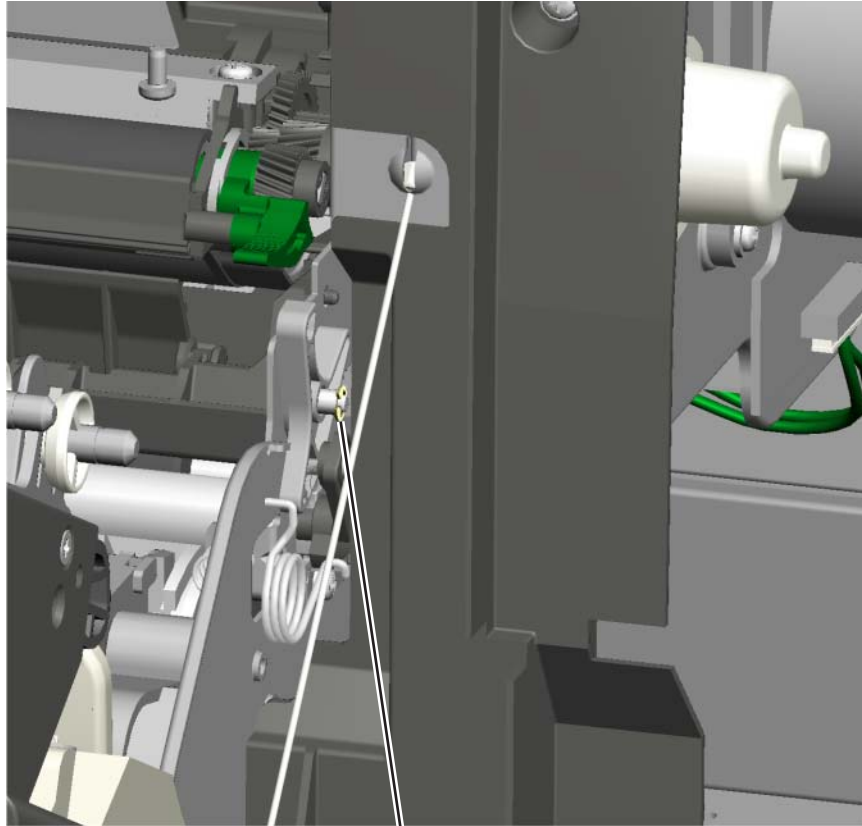

A

3. Remove the right bellcrank assembly.

System board removal

See the system board part number for the model you need on [page 7-9](#).



CAUTION

This product contains a lithium battery. THERE IS A RISK OF EXPLOSION IF THE BATTERY IS REPLACED BY AN INCORRECT TYPE. Discard used batteries according to the battery manufacturer's instructions and local regulations.

Warning: When replacing any one of the following components:

- Scanner MDC card
- System board

Only replace one component at a time. Replace the required component, and perform a POR before replacing a second component listed above. If this procedure is not followed, the printer will be rendered inoperable.

Warning: Be careful not to damage the ribbon cables when removing the system board.

1. Remove the left cover. See [“Left cover removal” on page 4-23](#).
2. Remove the rear frame cover. See [“Rear frame cover removal” on page 4-38](#).
3. Remove the hard disk if one is installed. See [“Hard drive assembly removal” on page 4-98](#).
4. Remove the wireless network card if one is installed. See [“Wireless network card removal” on page 4-188](#).
5. Remove the fax modem if one is installed. See [“Fax modem removal” on page 4-82](#).
6. Remove all the screws (A) from the left side of the printer so you can remove the system board, including:
 - USB port connector (1 screw)
 - Ethernet port connector (1 screws)
 - Modem shield (1 screws)
 - Hard disk shield (2 screws)
 - Ground screw (1 screw)

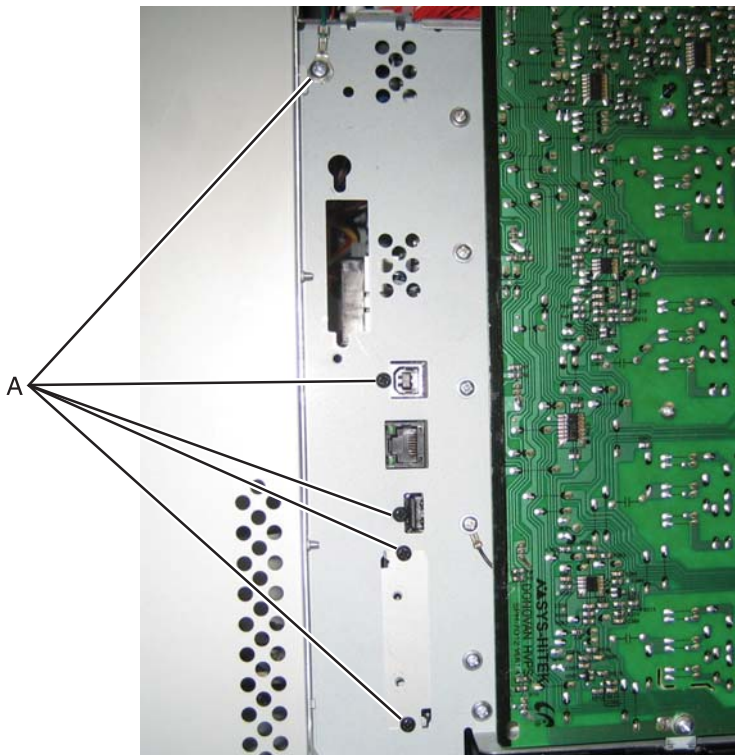

7. Remove any toroids by unclipping the fasteners.

Note: Be sure to note where you have removed the toroids, and replace them during installation.

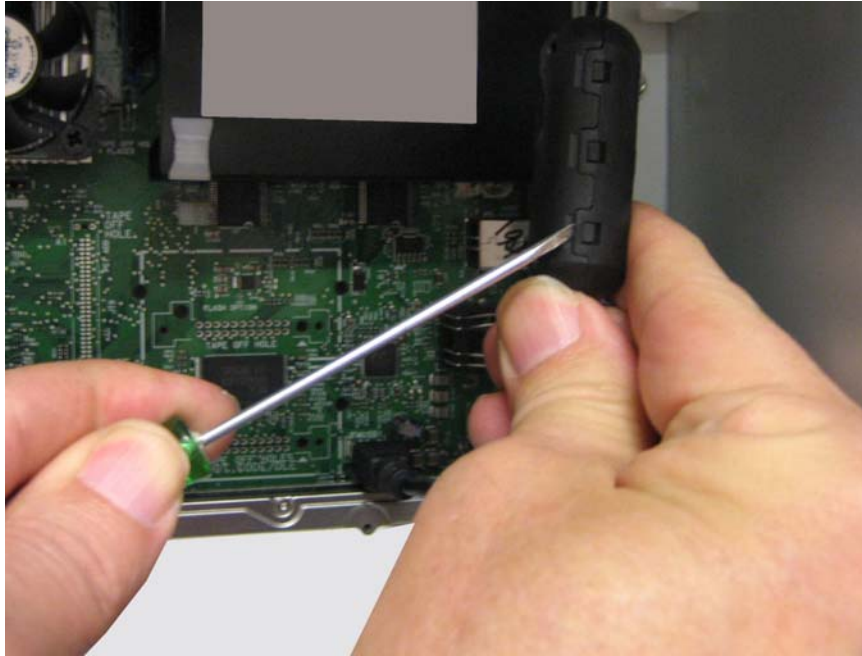

8. Disconnect all the cables from the system board.

Warning: Do not use tools to remove the UICC cable (B) or the printhead ribbon cable (C). Flat ribbon cables can be damaged and should be removed gently by hand. When installing, carefully line up the cable, and press straight into the connector.

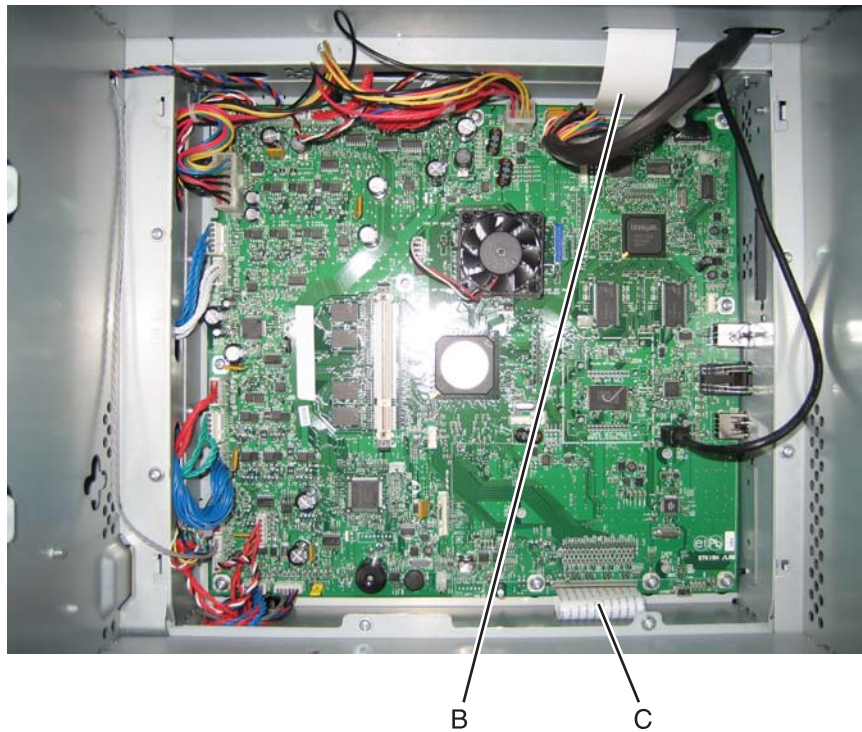

9. Remove the nine screws (D) from the system board.

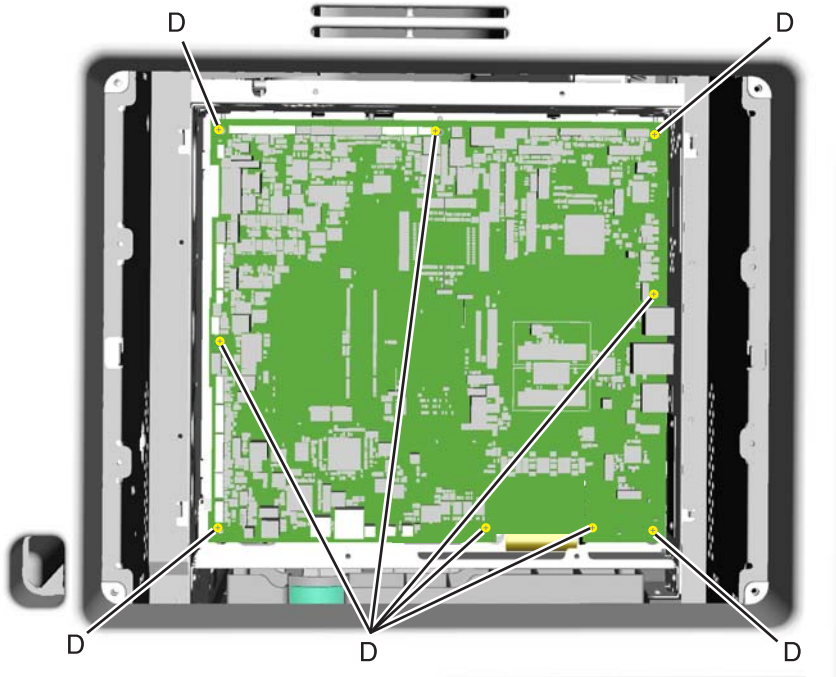

10. Remove the system board.

Installation notes:

1. Place the system board in position.

Note: Check that the mirror motor cable and the printhead cable do not rub against the edges of the frame.

2. Replace the nine screws (A) in the system board in the following order:
 - Loosely attach the four corners (A1) in a clockwise order, beginning with the left top corner.
 - Replace the USB connector screw (A2).
 - Replace the top center, right center side, and left center side (A3).
 - Tighten the top left corner and top right corner.
 - Replace the two screws on the center bottom (A4).
 - Tighten the bottom right and bottom left corners (A1).

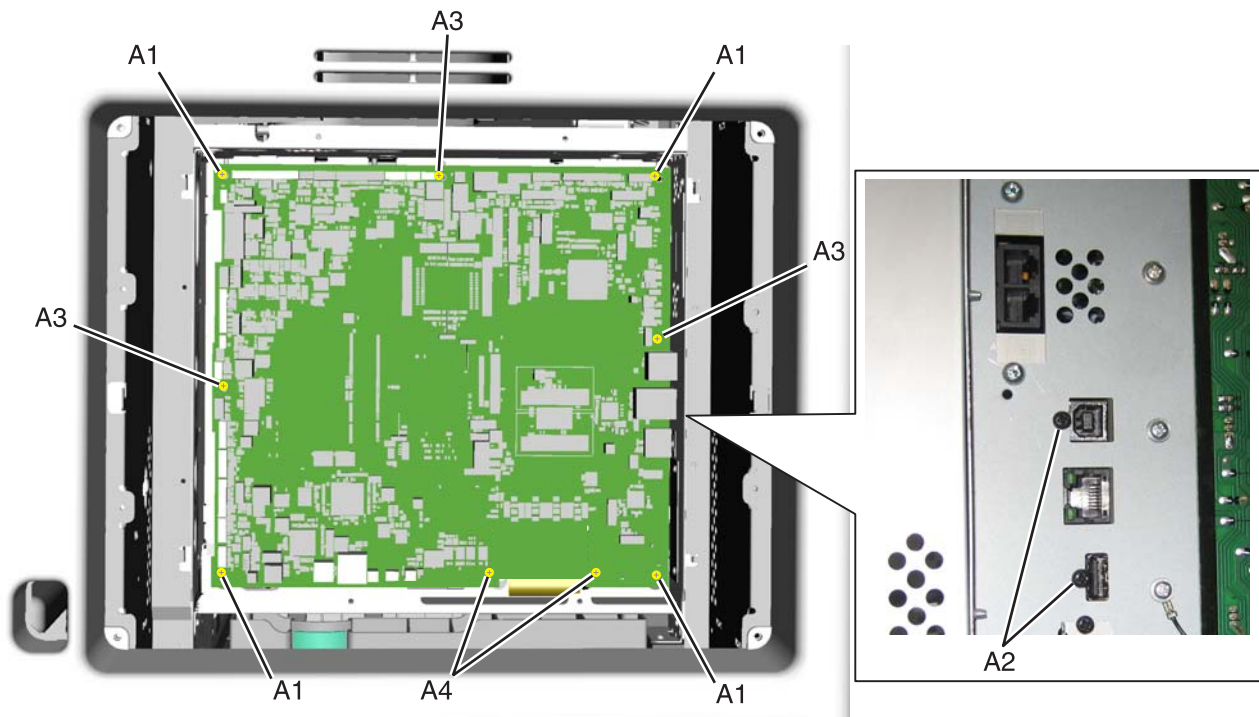

3. Route the cables through the access holes on the right side of the printer.

4. Replace all the screws (B) from the left side of the printer, including:

- Ethernet port connector (1 screws)
- Modem shield (1 screws)
- Hard disk shield (2 screws)
- Ground screw (1 screw)

Note: Be sure to attach the ground wire (C) to the ground screw.

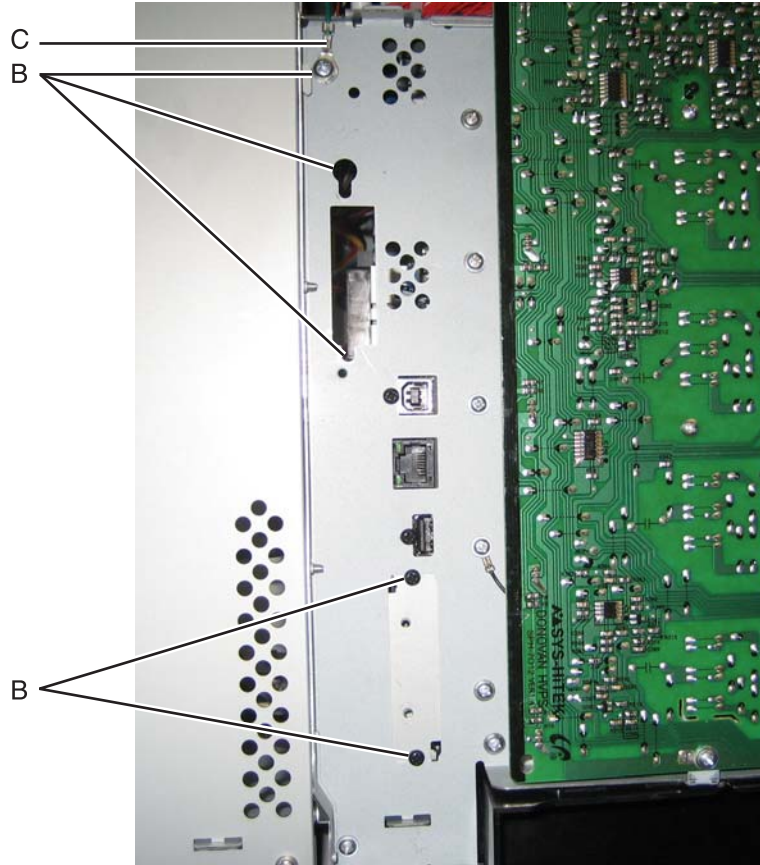

- c. Reconnect all the connectors to the system board. Use the diagram below for a guideline.

Warning: Be careful reconnecting the printhead ribbon cable (D) and the MDC cable (E). Ribbon cables can be damaged easily and should be handled carefully.

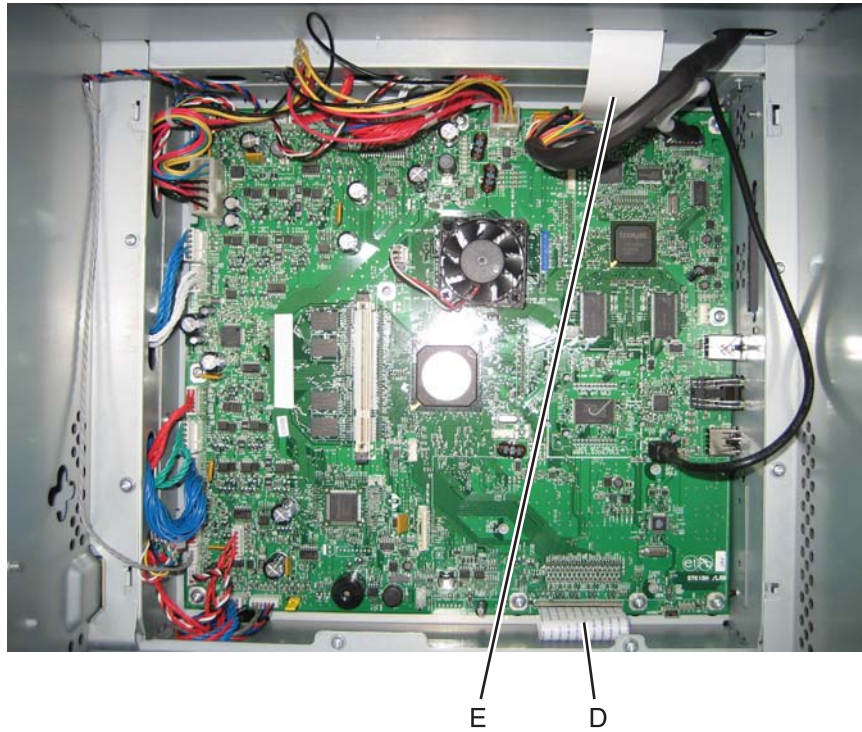

5. Install the toroids, hard disk, modem, and wireless network card, if appropriate.
6. Replace the rear cover, rear frame cover, and the left cover.

System board support shield removal

See “**System board support shield**” on page 7-9 for the part number.

1. Remove the system board. See “**System board removal**” on page 4-148.
2. Remove the right cover. See “**Right cover removal**” on page 4-39.
3. Pull the cables through the access holes on the right side of the printer.
4. Remove the five mounting screws (A) from the outer left side of the printer.
Note: Make a note of the attachment of the printhead ground cable (B) to the fourth screw from the top for later installation.
5. Remove the four screws (C) from the inner right side of the support shield.

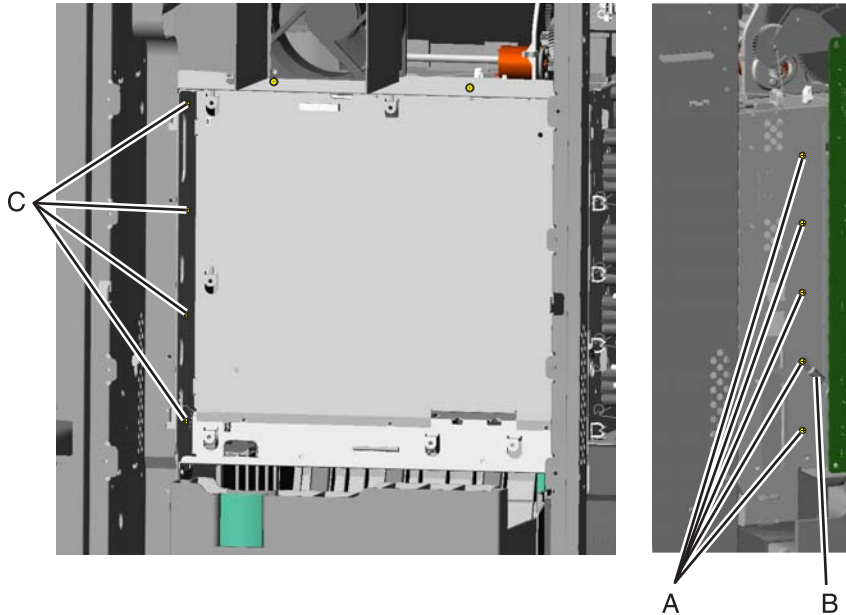

6. Remove the five mounting screws (D) from the top and bottom of the support shield.
Note: Only the ribbon and mirror motor cables come through the access holes in the system board support shield.

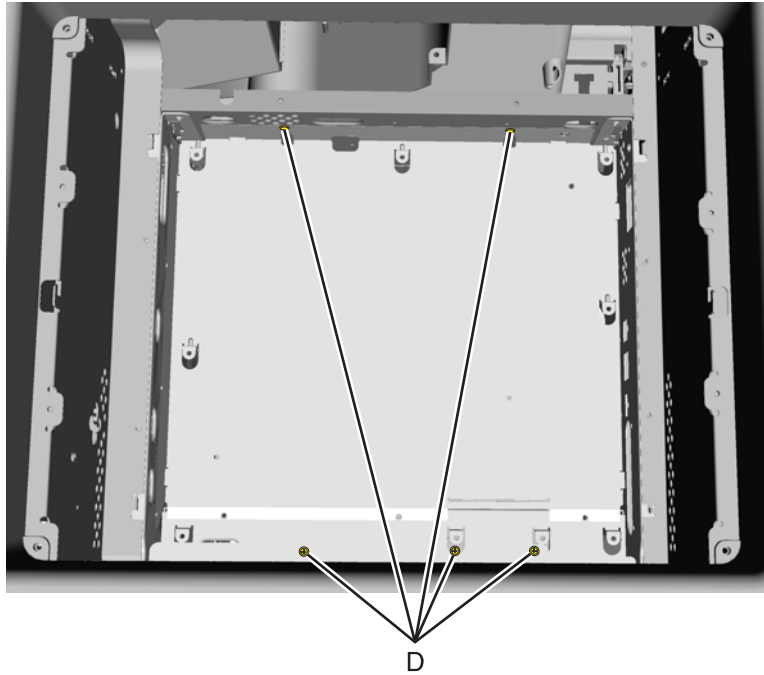

7. Lower and remove the support shield.
Note: Be careful not to damage the ribbon cables that route through the top and bottom frame of the printer.

Installation notes:

1. Loosely attach the two mounting screws (A).
2. Set the system board shield in place.
Note: Check that the ribbon cables do not rub against the edges of the frame.
3. Replace the remaining system board shield screws in the following order:
 - Replace the five screws (B) from the inner right side of the support shield.
 - Tighten the two mounting screws (A) to the top of the support shield.
 - Replace the three screws (C) from the bottom of the support shield.
 - Replace the five mounting screws (D) to the outer left side of the printer.**Note:** Be sure to connect the printhead ground cable (E) to the fourth screw from the top.

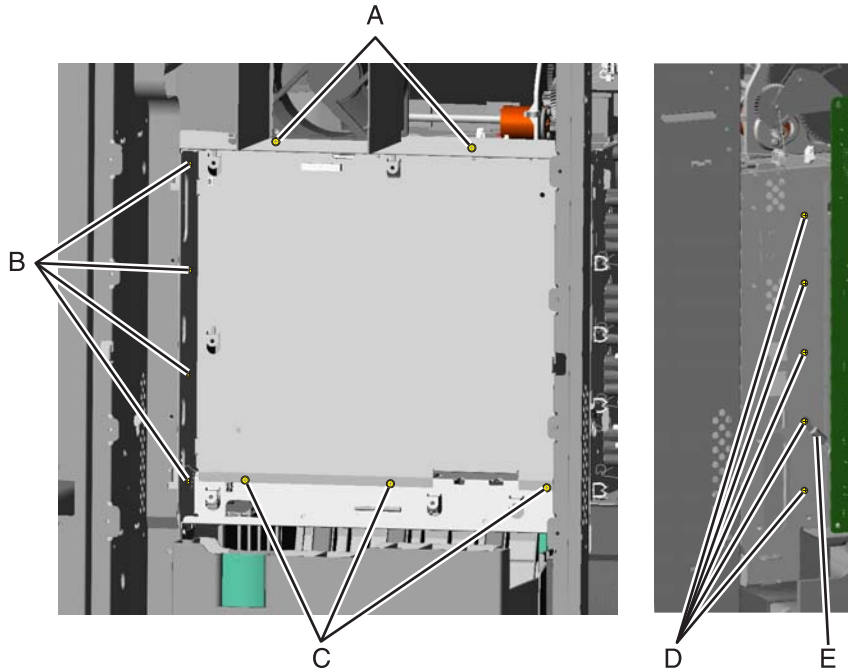

Toner level sensor removal

See **“Toner level sensor”** on page 7-11 for the part number.

Note the locations of the toner sensors.

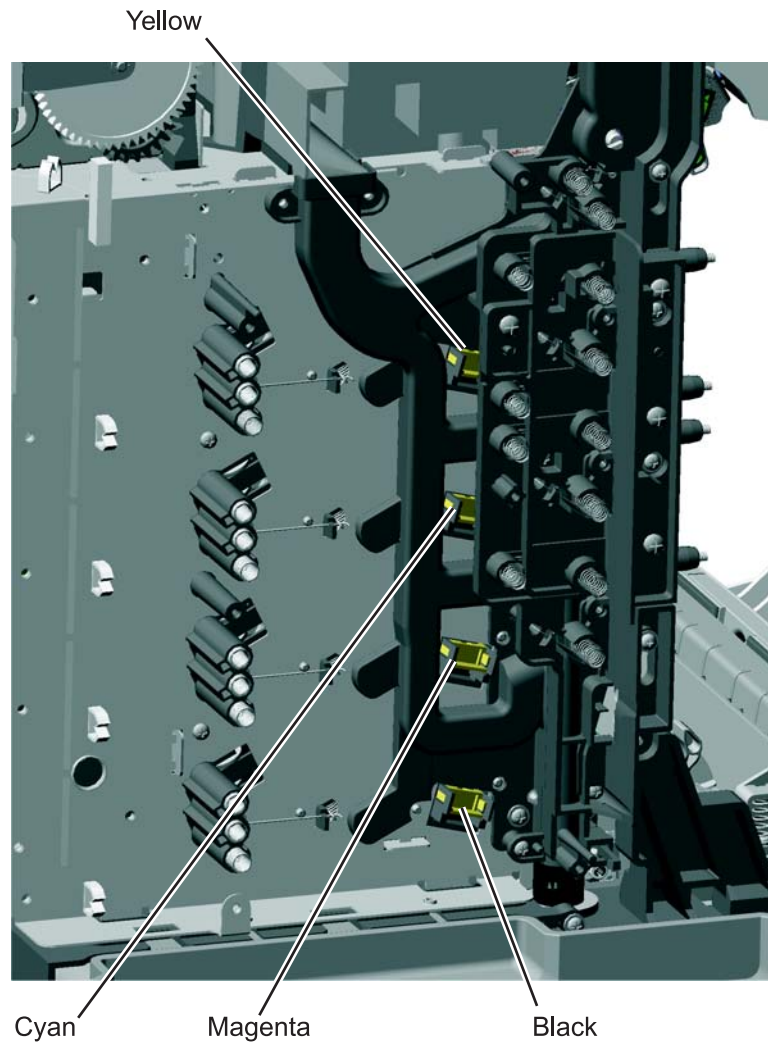

1. Remove the HVPS. See **“High-voltage power supply (HVPS) cable removal”** on page 4-102.
2. **For the upper two sensors:** These sensors are more difficult to reach because the toner is difficult to reach:
It is difficult to press both locking tabs at the same time. Using a spring hook, press the locking tab (A), and disengage the sensor on that side. Press the other locking tab (B), and remove the sensor.
Note: Use a slight pressure on the cable to keep the first locking tab from relatching, while you disconnect the second locking tab.

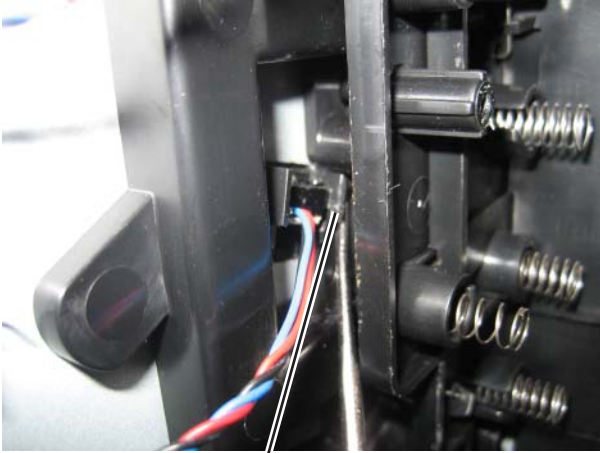

A

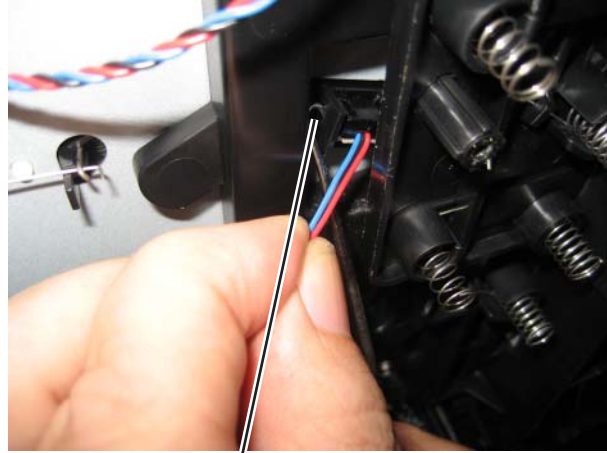

B

For the lower two sensors:

Using a spring hook, press the locking tab (C), and disengage the sensor on that side. Press the other locking tab (D), and remove the sensor.

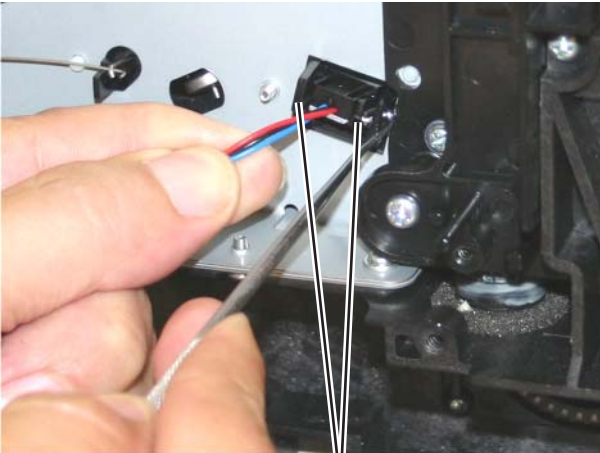

C

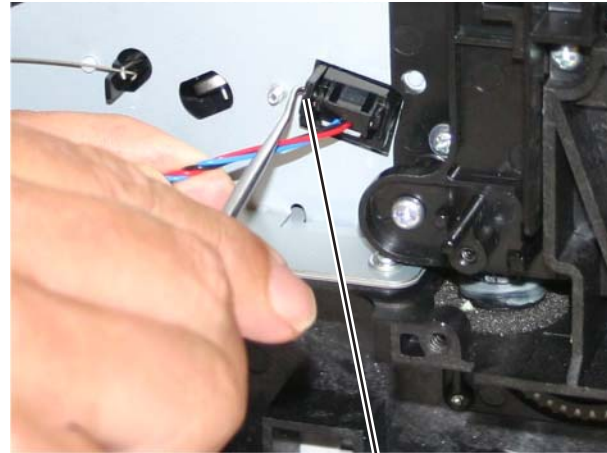

D

Top access cover links removal

Links come two in a package and fit either the right or the left.

Lower links

1. Open the top access cover.
2. Remove the side cover that corresponds to the link you need to replace. For example, if you are replacing the right lower link, remove the right cover.
3. Disconnect the spring (A).
4. Remove the two screws (B).



A B



B B A

5. Remove the link.

Upper links

1. Open the top access cover.
2. Remove the two screws (A) on the link that you need to replace.



A



A

3. Remove the link.

Top access cover sensor removal

This cable is gray.

1. Remove the rear frame cover. See **“Rear frame cover removal” on page 4-38**
2. Disconnect the cable in connector JFDS1, and remove the cable through the top left frame.

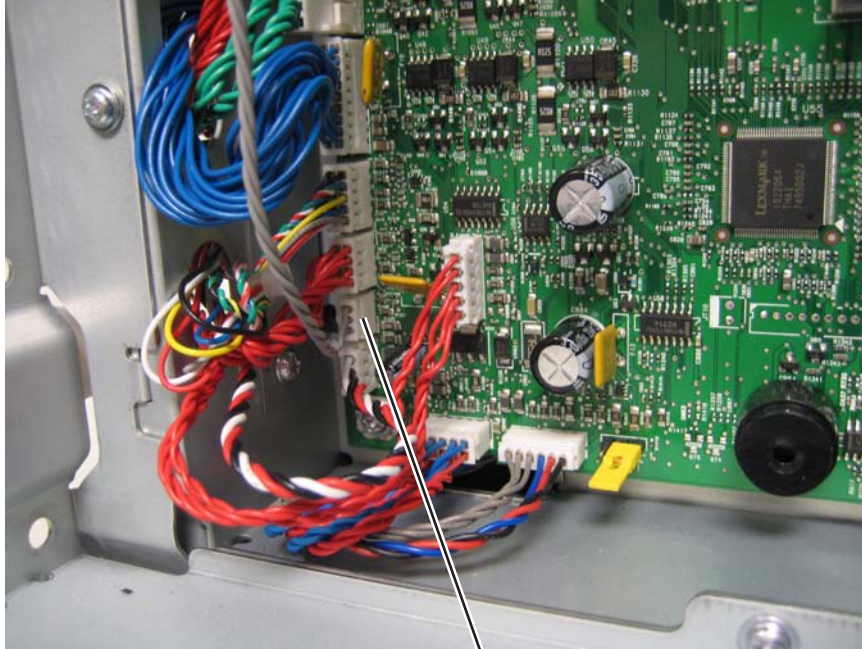

A

3. Remove the right cover. See **“Right cover removal” on page 4-39.**
4. Squeeze the latches (B) to disconnect the sensor from the top access cover.
5. Remove the sensor and cable through the opening (C).

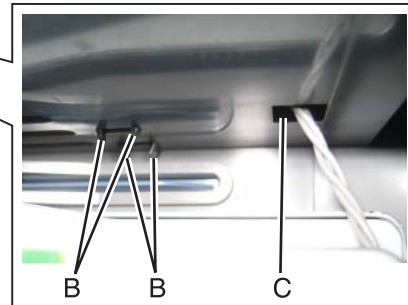
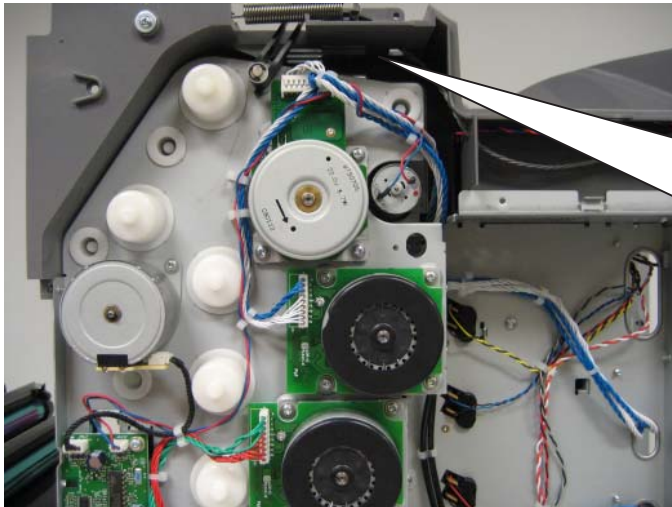

Installation notes:

1. Turn over the top access cover.
2. Snap the sensor into place.
Note: Make sure the sensor is replaced with the slot (A) in the center aligned with the gap in the top cover frame. Also note the placement of the cable connector.
3. Route the cable through the opening (B), and through the openings in the other side of the top cover assembly.

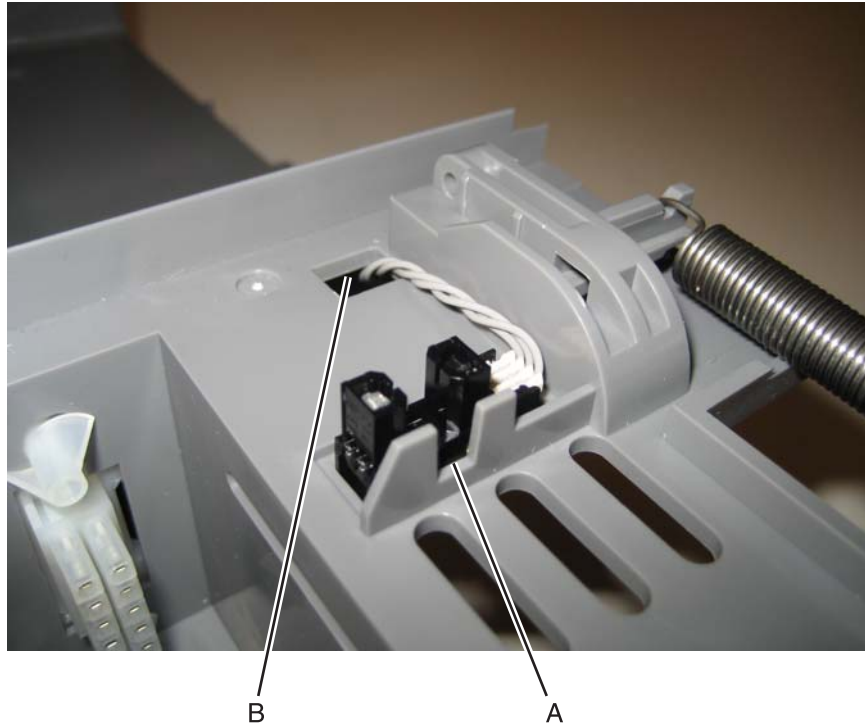

Top cover camshaft assembly removal

See for the part number.

1. Remove the top access cover. See **“Top access cover assembly removal” on page 4-41.**
2. Remove the fuser. See **“Fuser assembly removal” on page 4-94.**
3. Remove the top screw (A), and loosen the other screw (B). This will allow you to flex the EP drive.

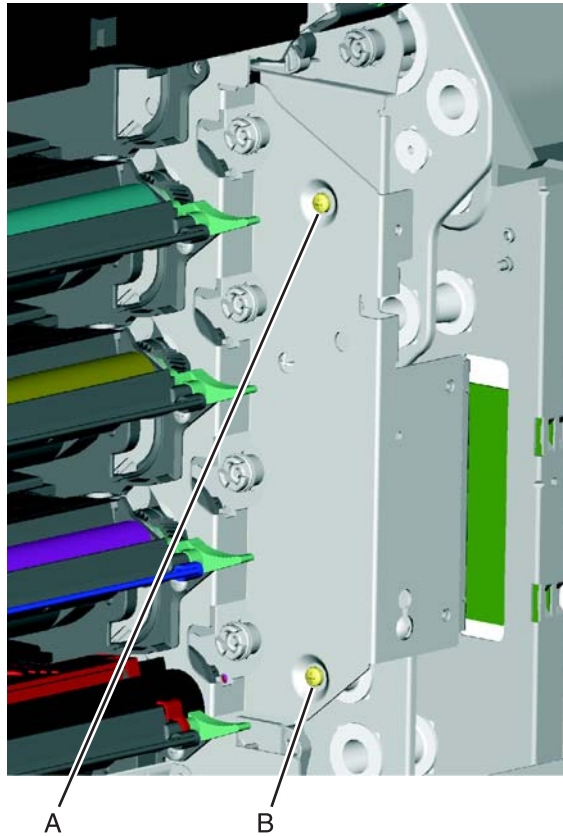

4. Remove the two screws (C).

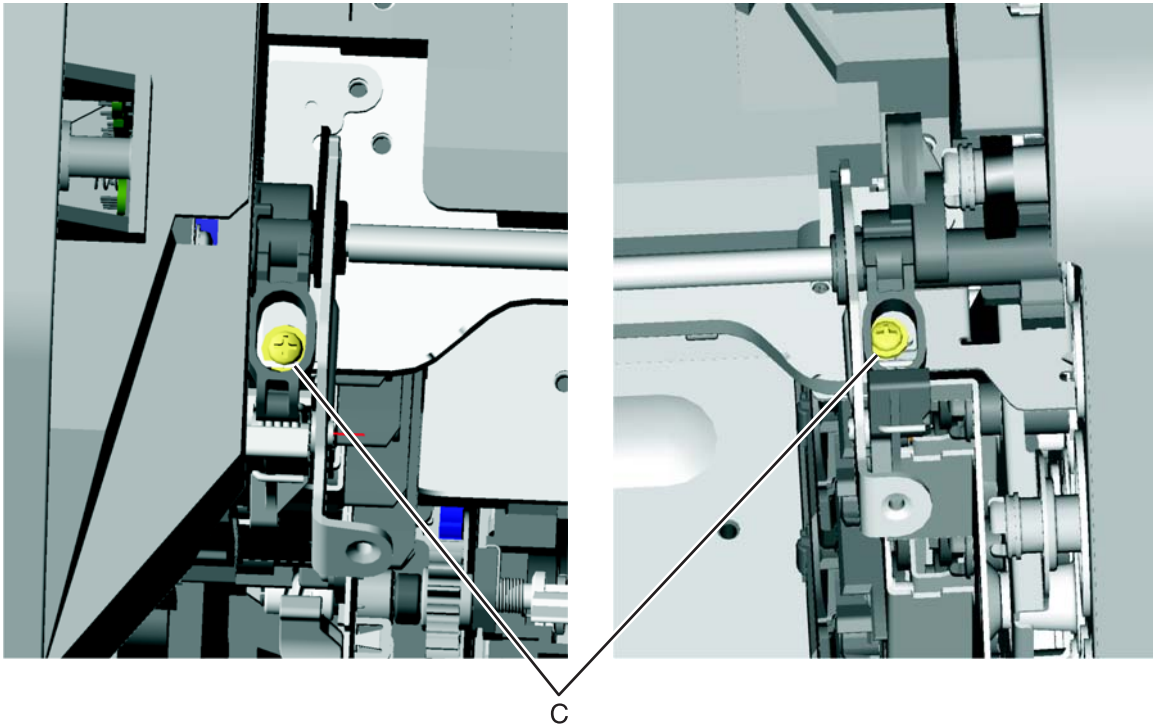

5. Rotate the camshaft up using the camshaft actuator handle (D) so you can access the other two screws (E), and remove them.

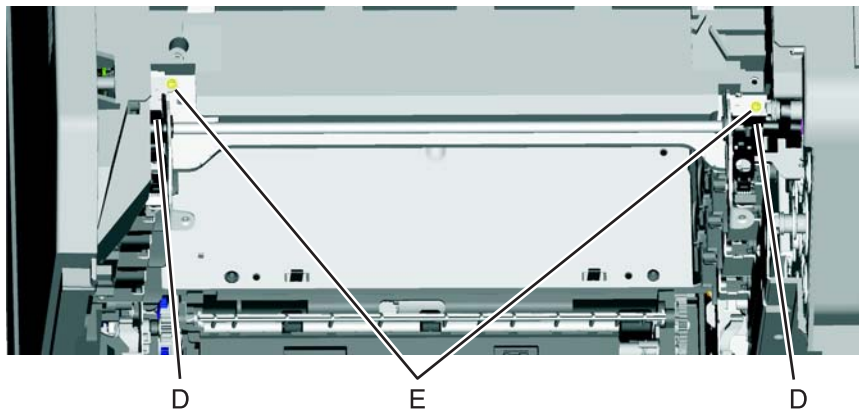

6. Flex the EP drive assembly to remove the right side of the camshaft from the boss (F) and lift to remove the camshaft.

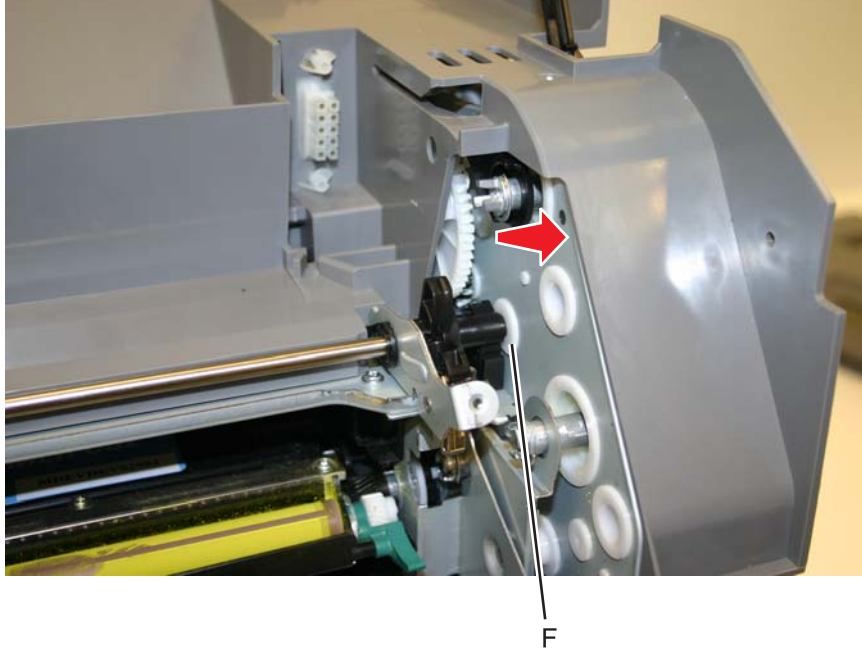

Installation notes:

1. On the left side, align the mark on the idler gear (A) with the mark on the camshaft gear (B), and slide the camshaft into place, meshing the gears on the left side.

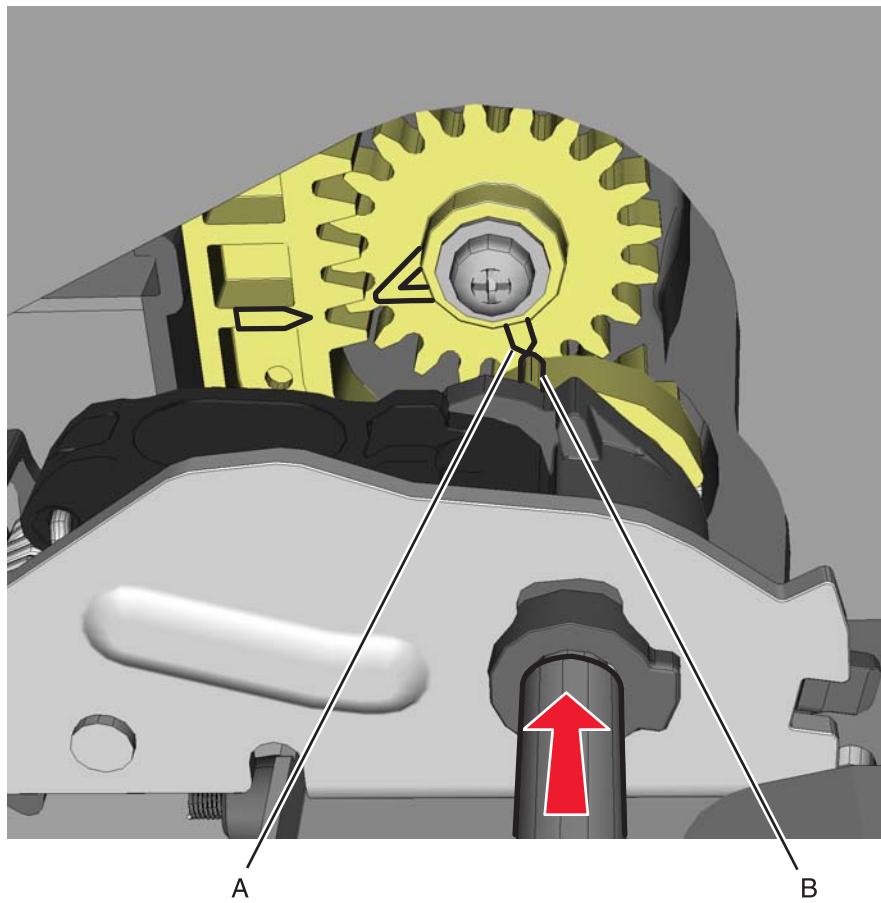

2. Rotate the camshaft up using the camshaft actuator handle (C), and make sure the gears on the right side mesh so the first gear tooth of the camshaft aligns with the first two gear teeth of the EP drive actuator rack (D).
Note: Make sure the actuator rack on the EP drive is all the way back.
3. Flex the EP drive on the right to seat the end of the shaft into the boss (E) on the EP drive.

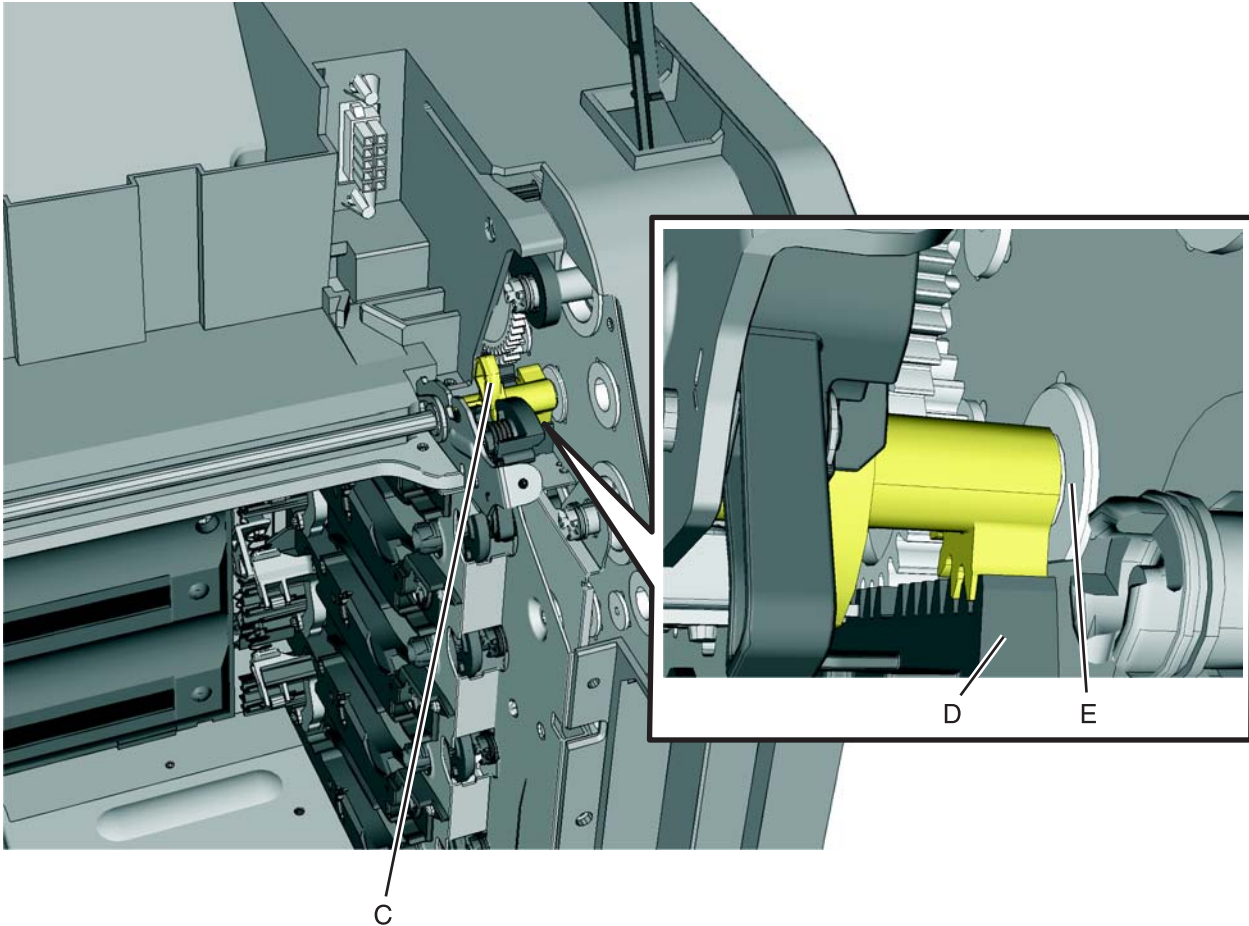

4. Rotate the camshaft up using the camshaft actuator handle (F) so you can access the other two screws (G), and remove them.

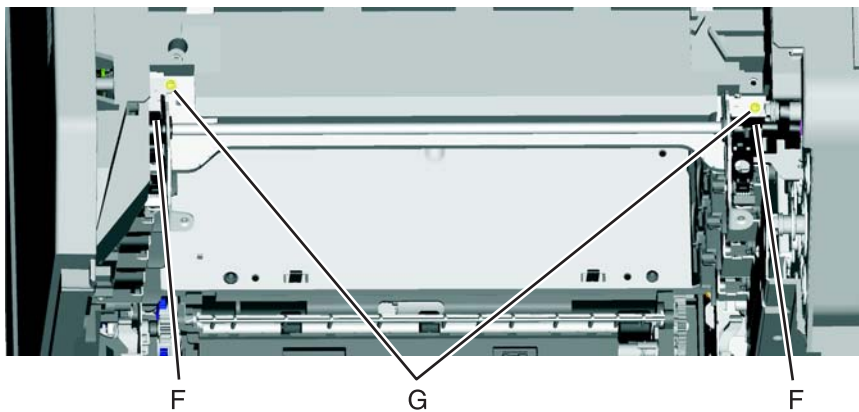

5. Rotate the camshaft using the camshaft actuator handle, and replace the two screws (H).

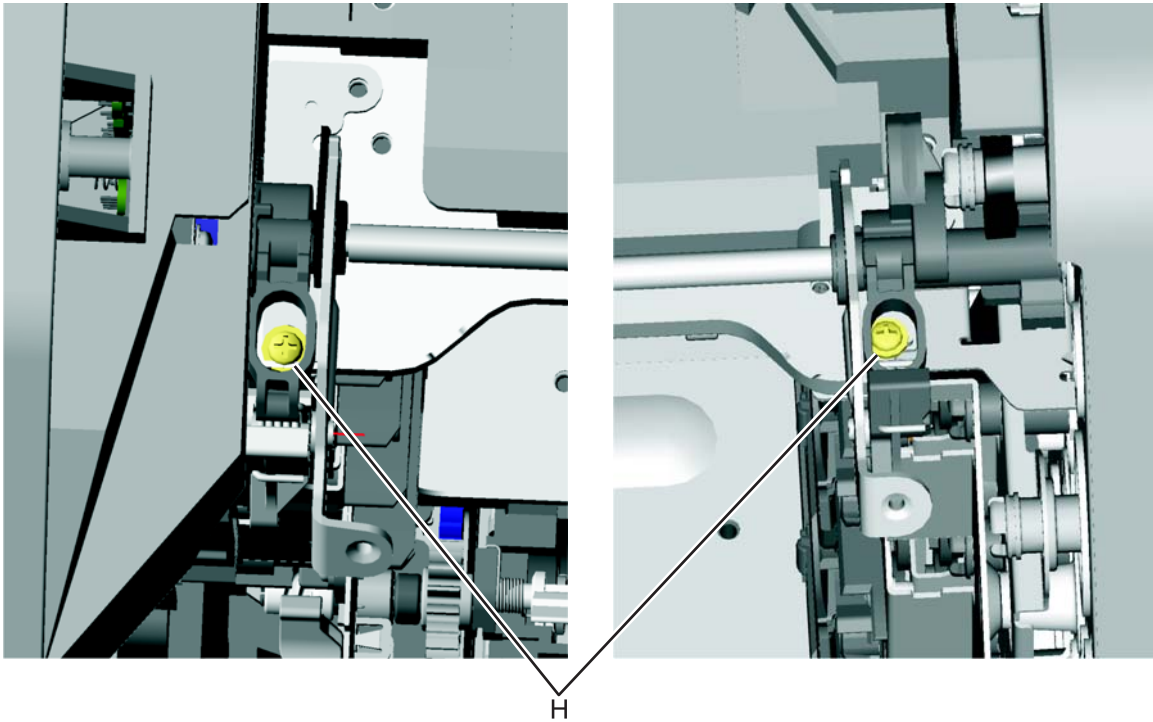

6. Replace the screw in the EP drive that allowed you to flex the EP drive, and tighten the other screw (see step 4 of the removal).
7. Replace the top access cover assembly
8. Replace the fuser, the cartridges, and close the covers.

Transfer module removal

See “**Transfer module**” on page 7-5 for the part number.

1. Open the top access cover.
2. Open the front access door.
3. Disconnect the transfer module cable (A).
4. Press the two tabs (B) to release the front access cover assembly.
5. Press the two tabs (C) on either side of the transfer module, and lift out the transfer module.

Note: Leave the photoconductor units on the transport belt when removing.

Warning: To avoid damaging the photoconductor drum, place the transfer module with the photoconductor units on a clean surface. Never expose the photoconductor units to light for a prolonged period of time. Place a clean, dry cloth over the transfer module and photoconductor units until they are required. Lower the front access door cover.

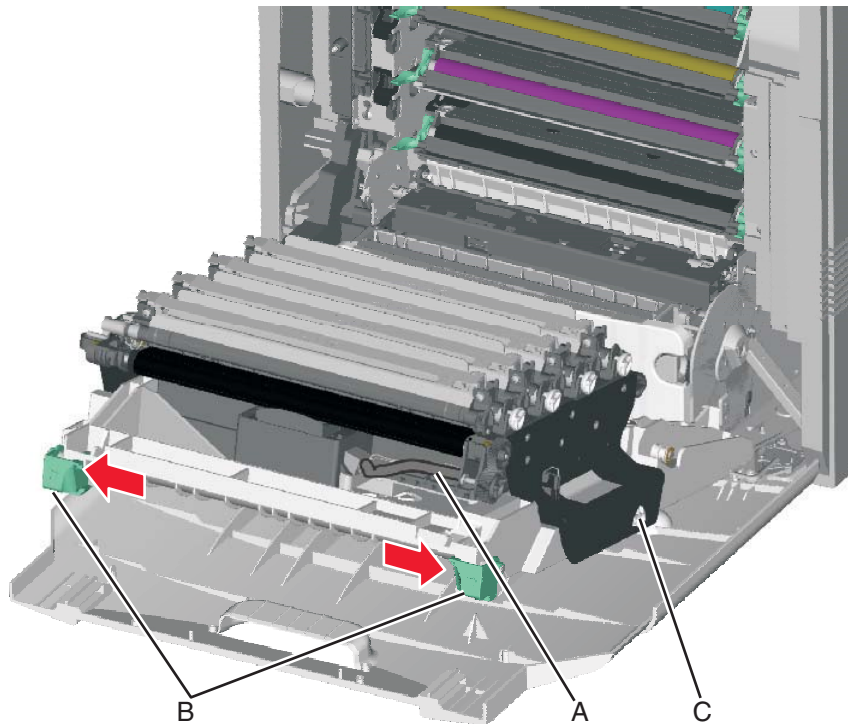

Note: If you are removing the transfer module to access another part, leave the photoconductor units attached, and you are done. If you need to replace the transport belt, continue with the next step to remove the separate photoconductor units.

6. Remove the photoconductor units. Lift the right end handle (D) of the photoconductor unit, releasing from the mount.
7. Lift the unit up and away from the left side of printer, ensuring the left end of the photoconductor is released from the holding pin (E).

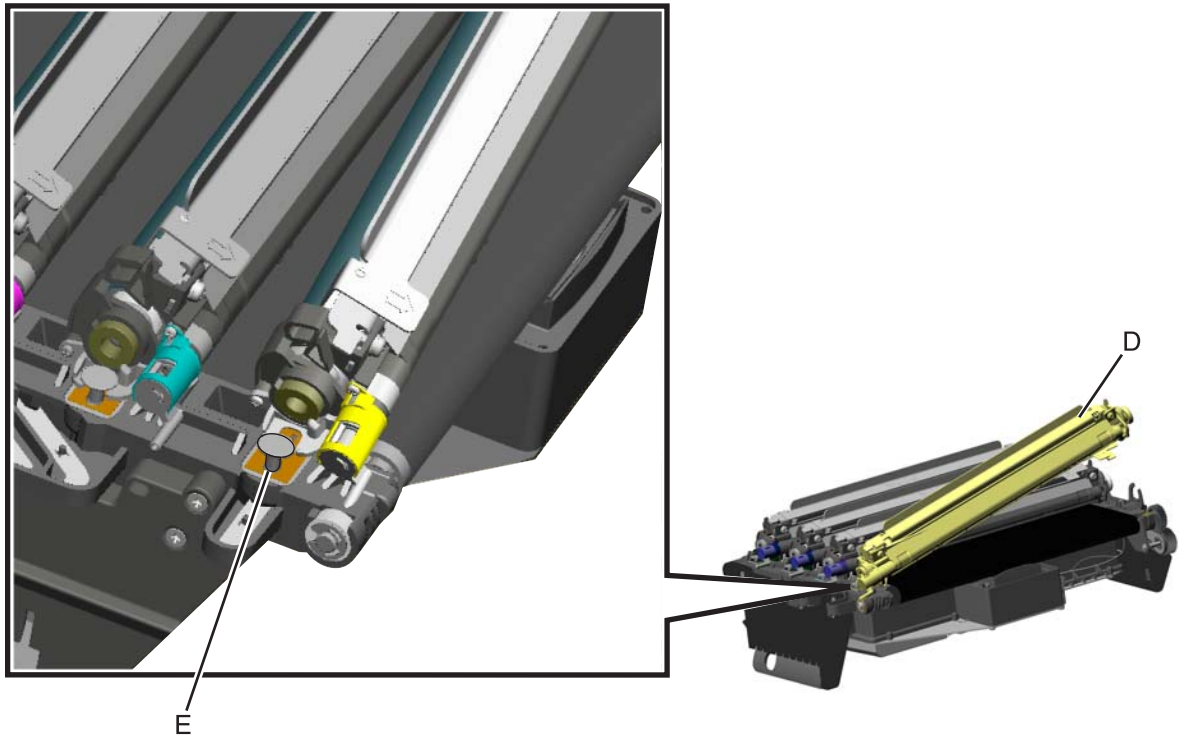

Transport cable removal

1. Remove the LVPS. See **“Low-voltage power supply (LVPS) removal”** on page 4-104.
 2. Disconnect the transfer module cable (transport cable) (A).
 3. Press the two tabs (B) to release the front access cover assembly.
 4. Press the two tabs (C) on either side of the transfer module, and lift out the transfer module.
- Note:** Leave the photoconductor units on the transport belt when removing.

Warning: To avoid damaging the photoconductor drum, place the transfer module with the photoconductor units on a clean surface. Never expose the photoconductor units to light for a prolonged period of time. Place a clean, dry cloth over the transfer module and photoconductor units until they are required. Lower the front access door cover.

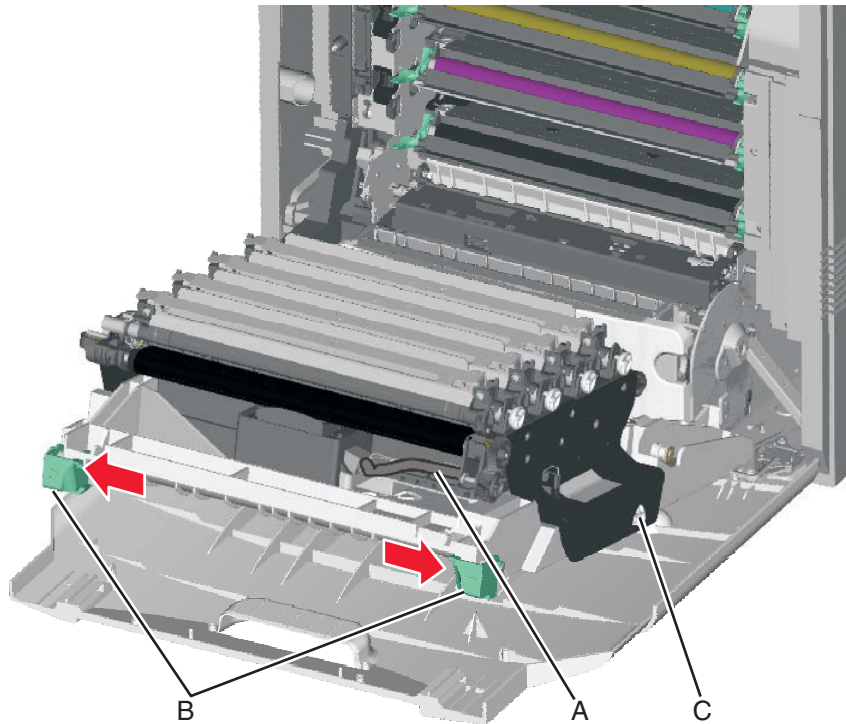

5. Disconnect the transport cable from the system board at JTPS1 connector (D).
Note: The cable connector on the system board end of the cable is smaller than the connector on the front access door, and it may be easier to get that end through the openings.

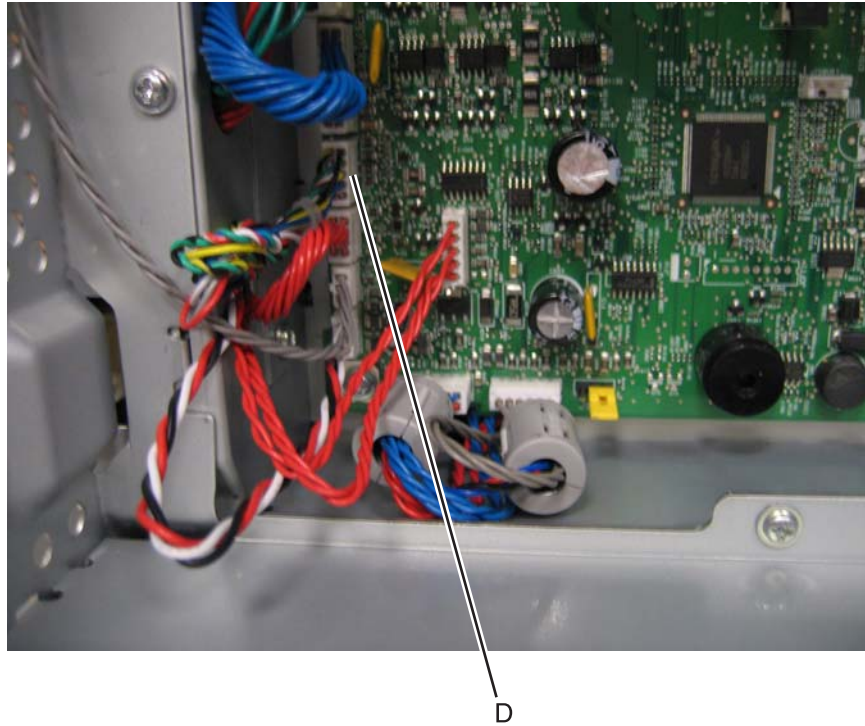

6. Extract the cable through the opening in the frame to the right side of the printer (E).
7. Remove the cable from the five cable restraints (F).
8. Remove the cable from the three openings in the cable channel (G) on the right side of the front access door.

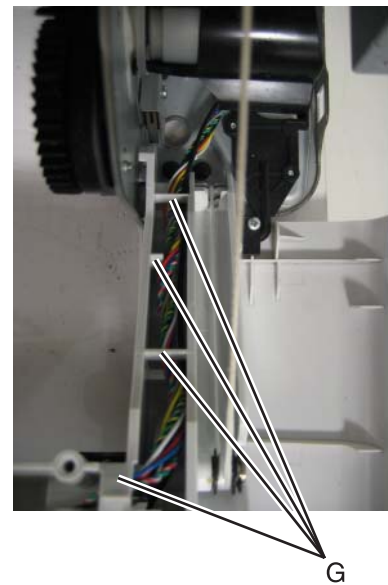
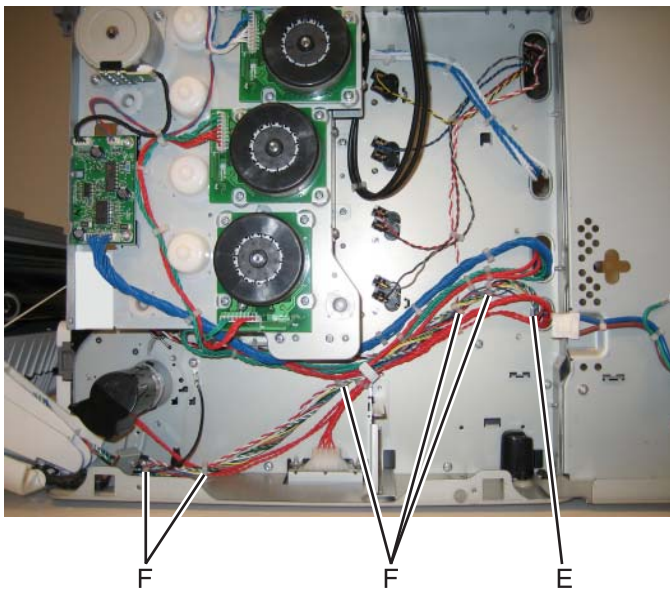

9. Remove the six screws (H) from the cable shield.

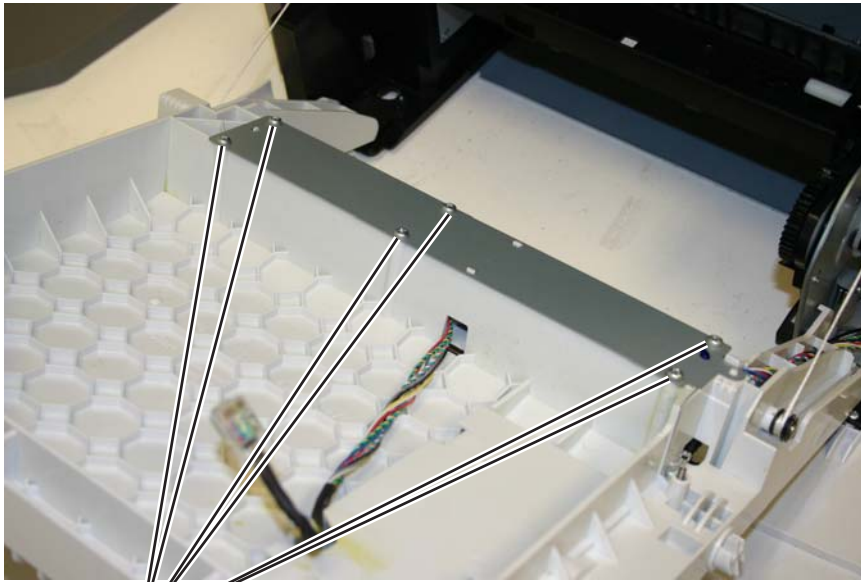

H

10. Remove the cable through the cable channel (J).

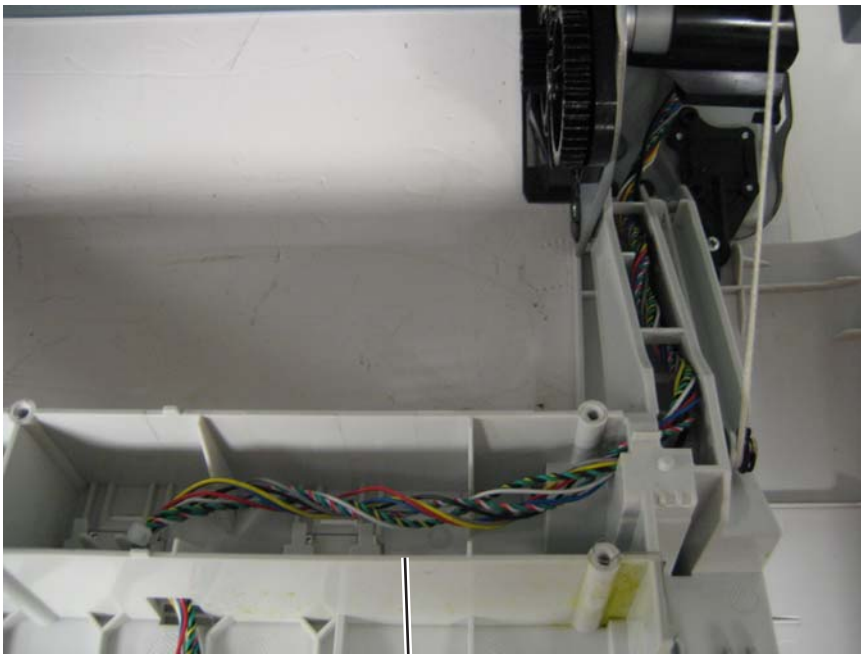

K

Transport motor cable removal

1. Remove the right cover. See **“Right cover removal”** on page 4-39.
2. Disconnect the cable from the transport motor drive (A).
3. Disconnect the cable from the transport motor (B).

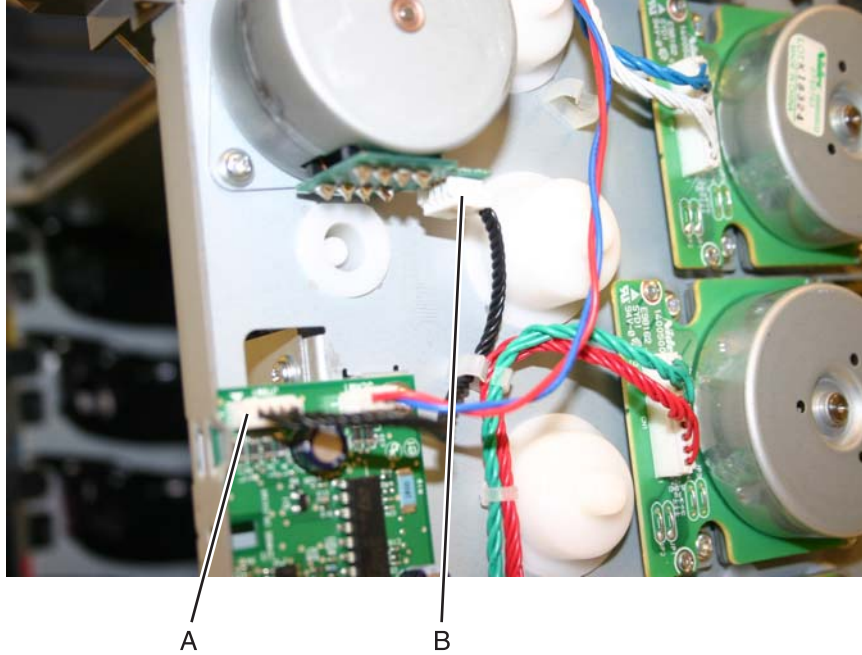

4. Remove the cable.

UICC card removal

1. Remove the top access cover assembly. See **“Top access cover assembly removal”** on page 4-41.
2. Place the top access assembly on a soft link-free cloth with the touchscreen facing down.
3. Remove the six smaller screws (A) securing the position guide.

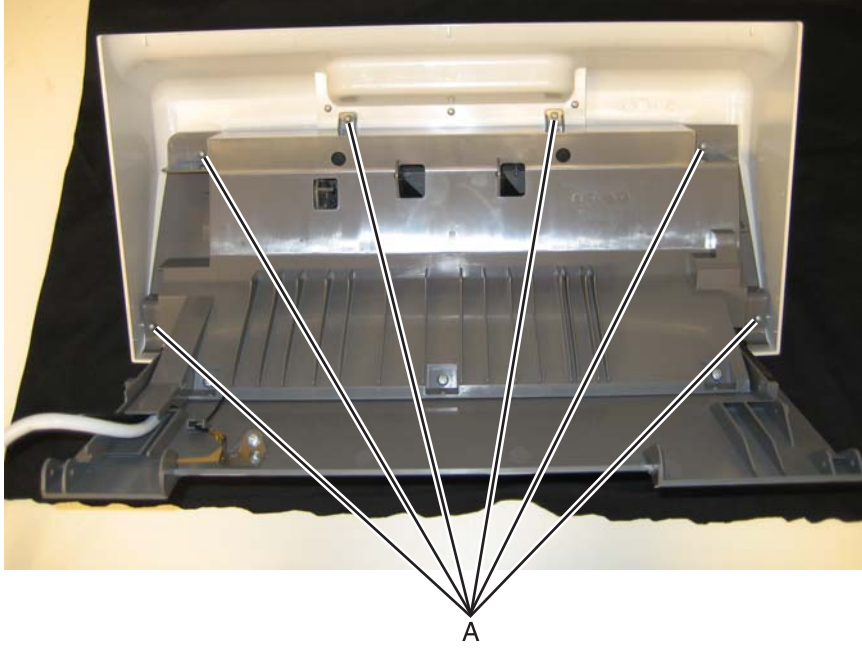

4. Remove the five larger screws (B) and the two smaller screws (C).

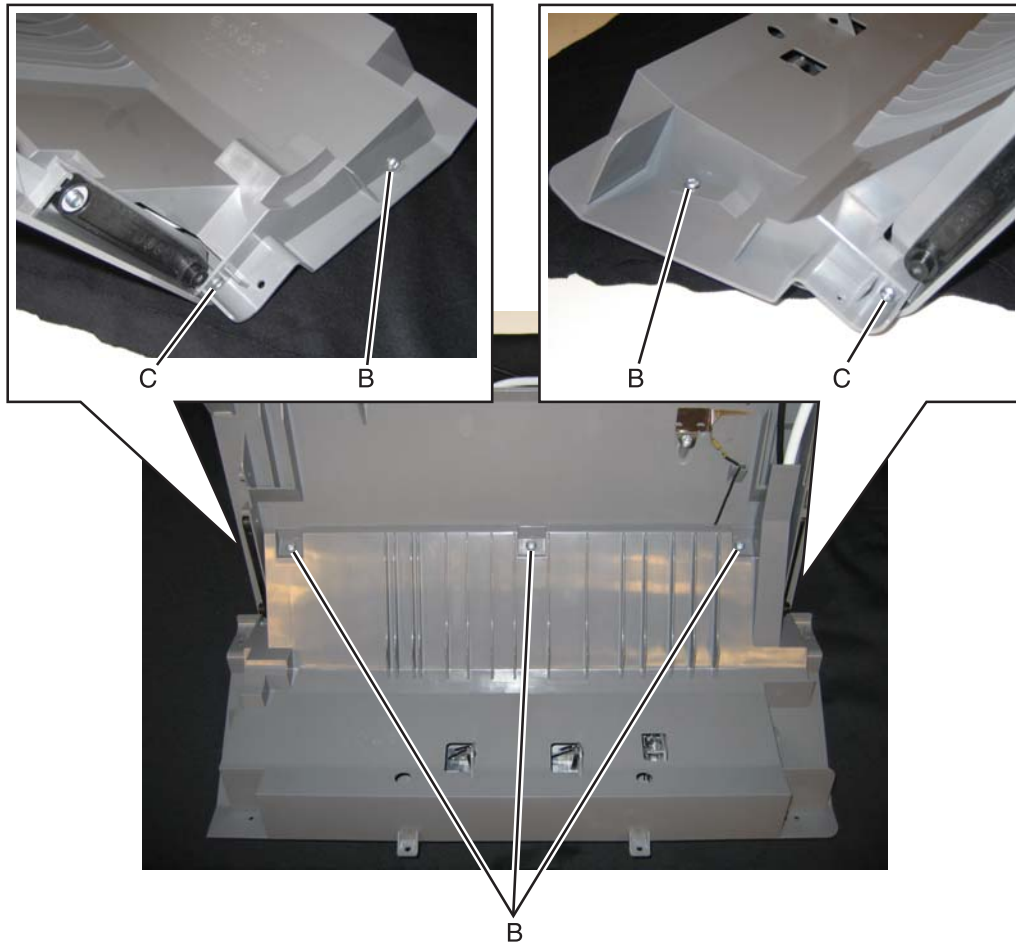

5. Lift the position guide, so you can access the cables.
6. Flip open the lock (D) on the wide ribbon cable, and remove the cable from the connector.

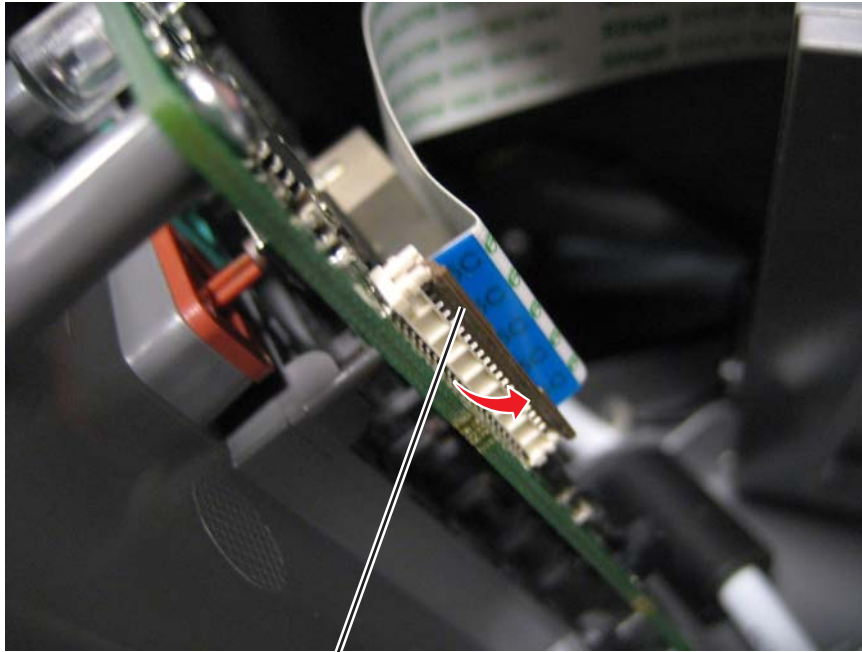

D

7. Carefully pull the display cable (E) straight out to disconnect it.
8. Remove the screw (F) and disconnect the ground cable.



E

F

9. Remove the position guide.



10. Disconnect the UICC cable (F).
11. Remove the three screws (G) from the operator panel card.

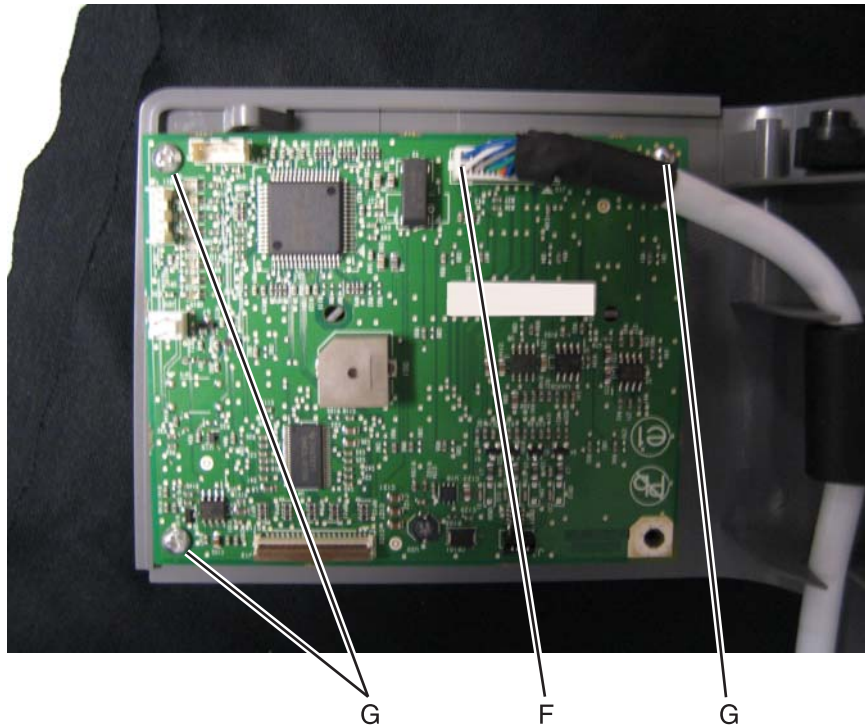

12. Remove the UICC card.

UICC cable removal

1. Remove the top access cover assembly. See **“Top access cover assembly removal”** on page 4-41.
2. Place the top access assembly on a soft link-free cloth with the touchscreen facing down.
3. Remove the six smaller screws (A) securing the position guide.

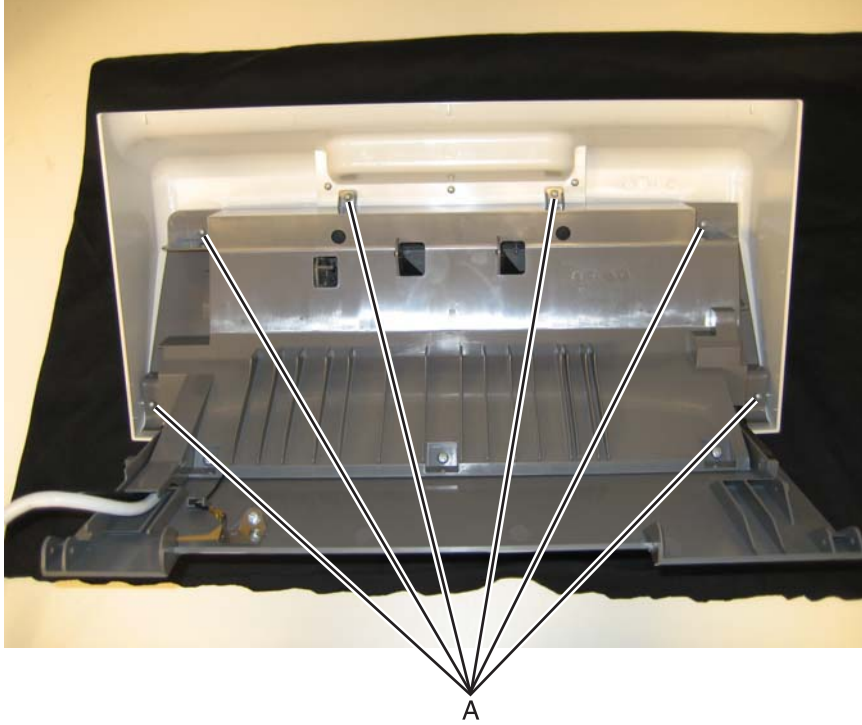

4. Remove the five larger screws (B) and the two smaller screws (C).

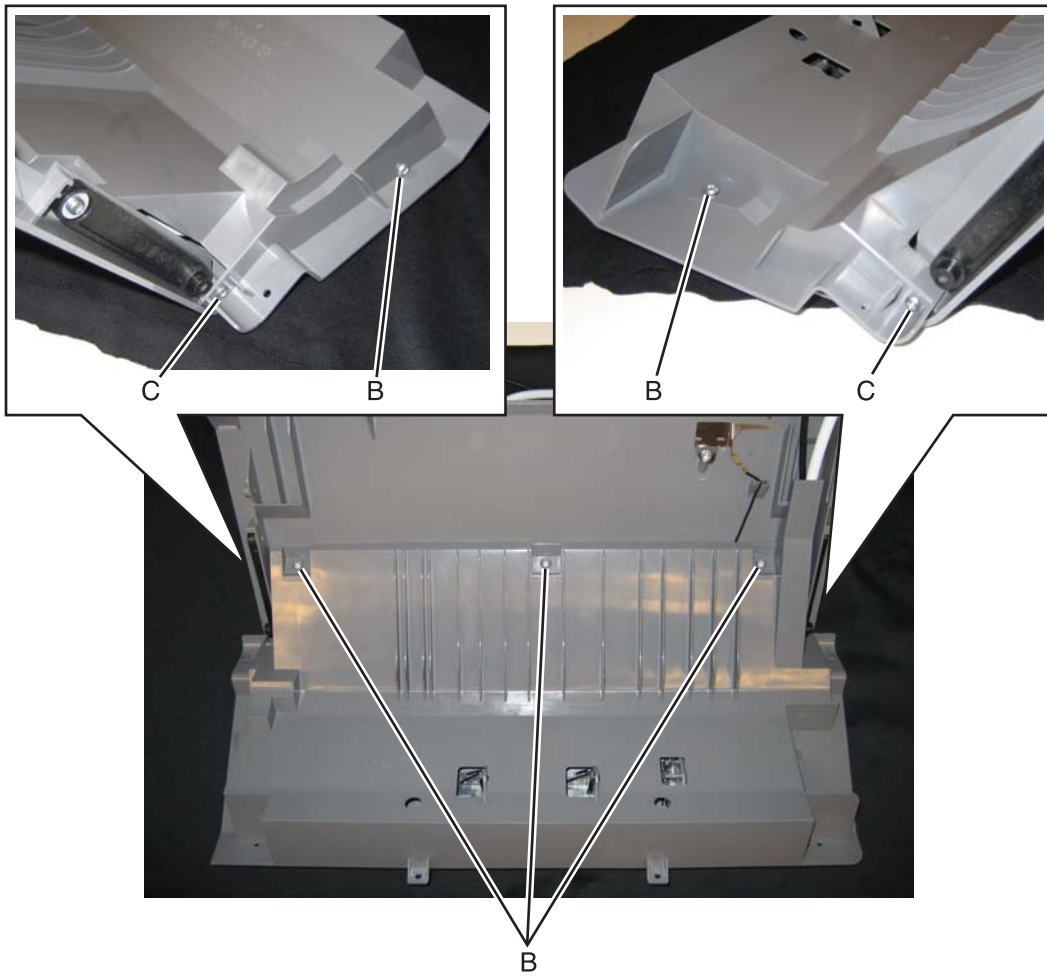

5. Lift the position guide, so you can access the cables.

6. Flip open the lock (D) on the wide ribbon cable, and remove the cable from the connector.

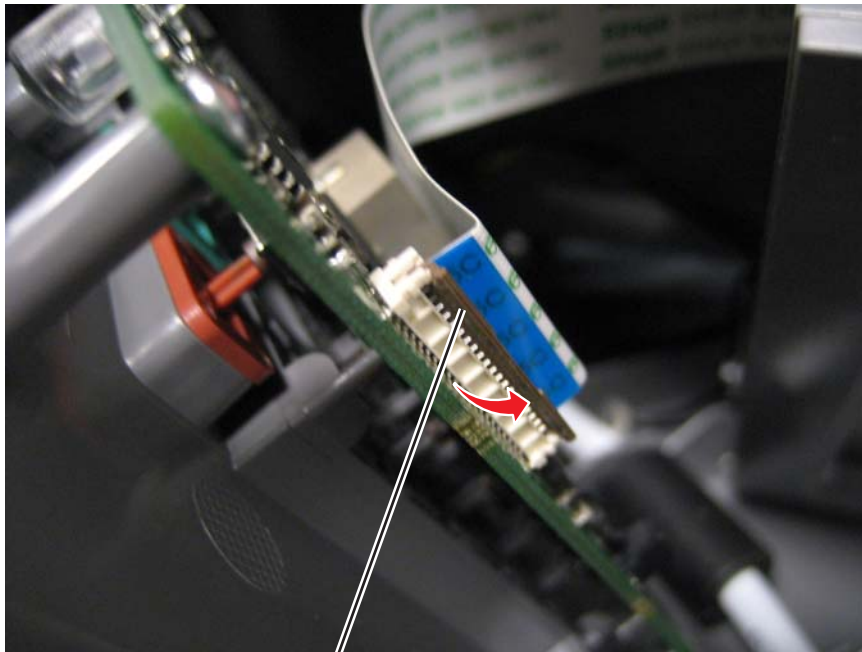

D

7. Disconnect the display cable (E) by pulling it straight out.
8. Remove the screw (F) and disconnect the ground cable.



E

F

9. Remove the position guide.

10. Disconnect the UICC cable (G), and remove the cable from the cable retainers (H).

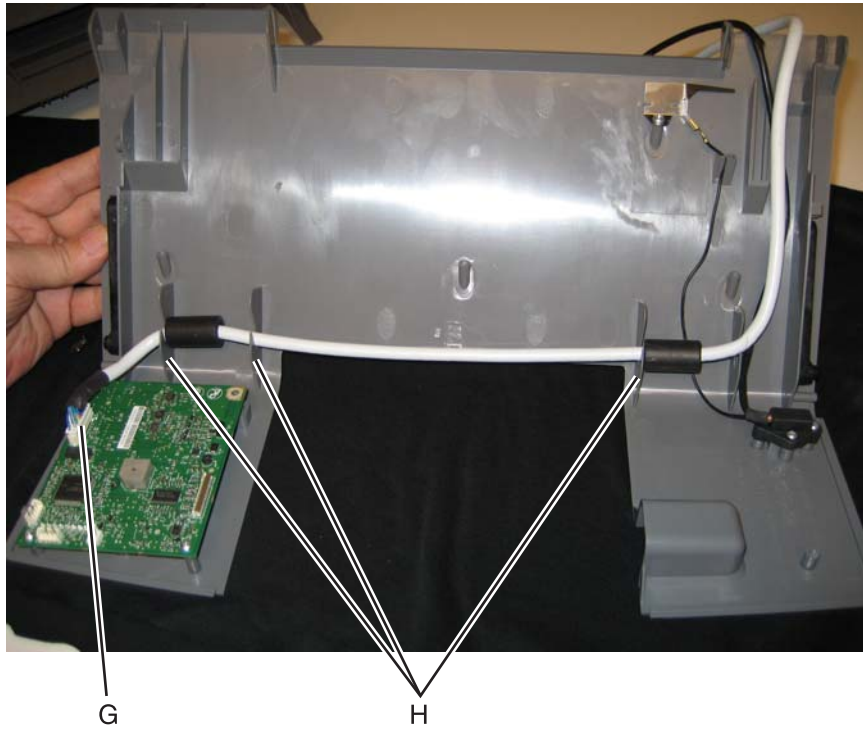

11. Remove the UICC card.

USB connector cable removal (front panel)

1. Remove the top access cover. See **“Top access cover assembly removal” on page 4-41.**
2. Place the top access assembly on a soft link-free cloth with the touchscreen facing down.
3. Remove the six smaller screws (A) securing the position guide.

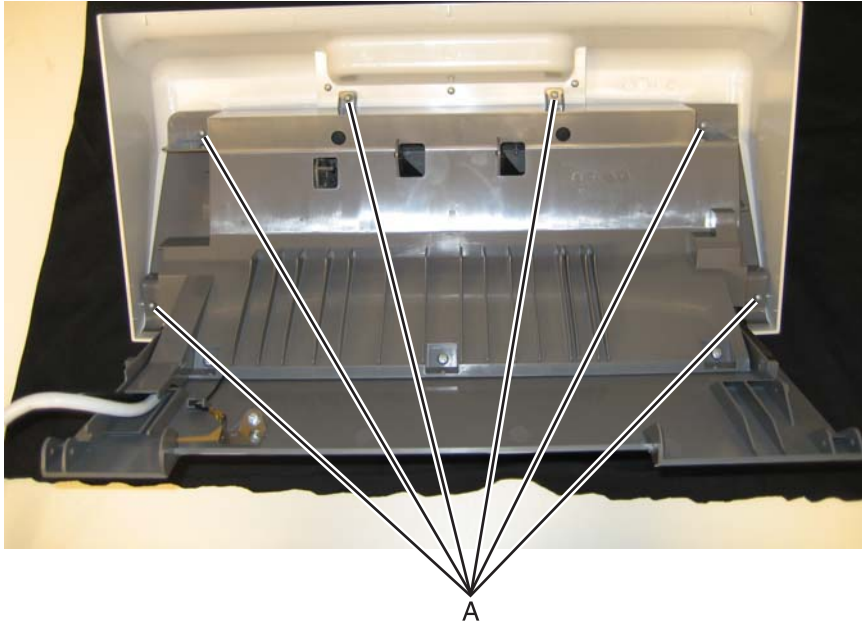

4. Remove the five larger screws (B) and the two smaller screws (C).

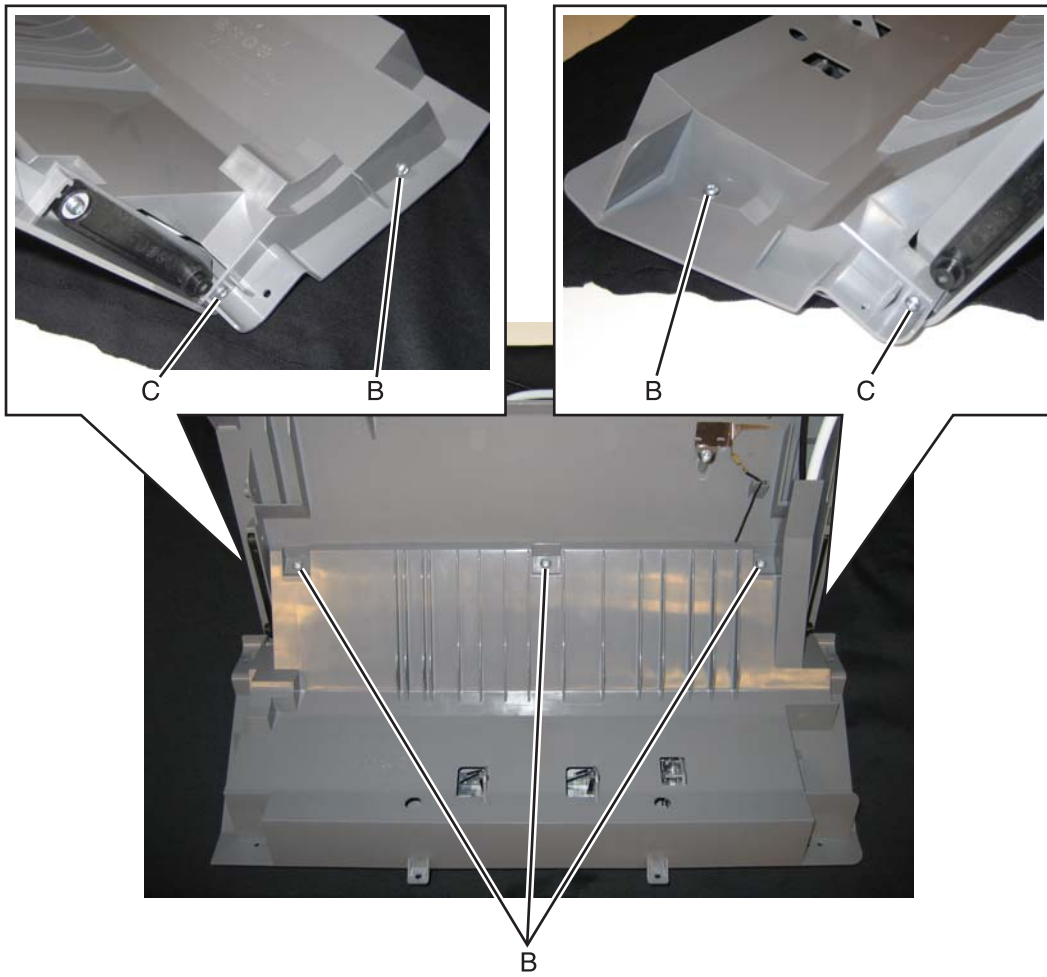

5. Lift the position guide, so you can access the cables.

6. Flip open the lock (D) on the wide ribbon cable, and remove the cable from the connector.

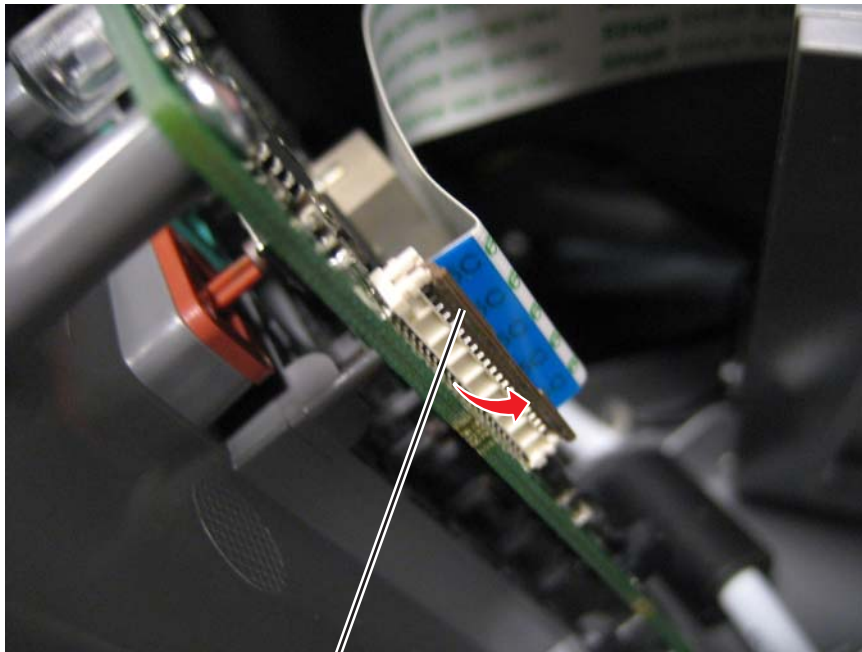

D

7. Disconnect the display cable (E) by pulling it straight out.
8. Remove the screw (F) and disconnect the ground cable.



E

F

9. Remove the position guide.

10. Disconnect the USB ground cable (G).
Note: Take note of the routing of the ground cable.
11. Remove the two screws (H) that secure the USB connector.

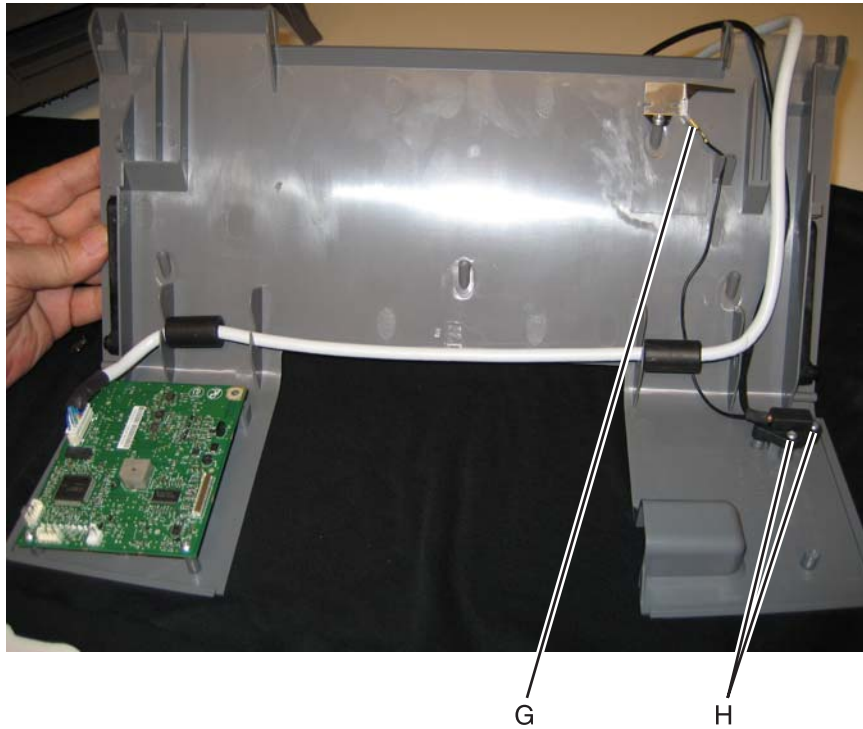

12. Remove the USB connector cable, the ground cable, and the connector.

Waste toner assembly removal

Not a FRU.

- 1.** Press the waste toner release latch (A).
- 2.** Swing the front of the waste toner assembly away from the printer and remove.



A

Wireless network antenna removal

1. Remove the wireless network card. see **“Wireless network card removal”** on page 4-188.
2. Disconnect the wireless network antenna cable (A) from the wireless network card.

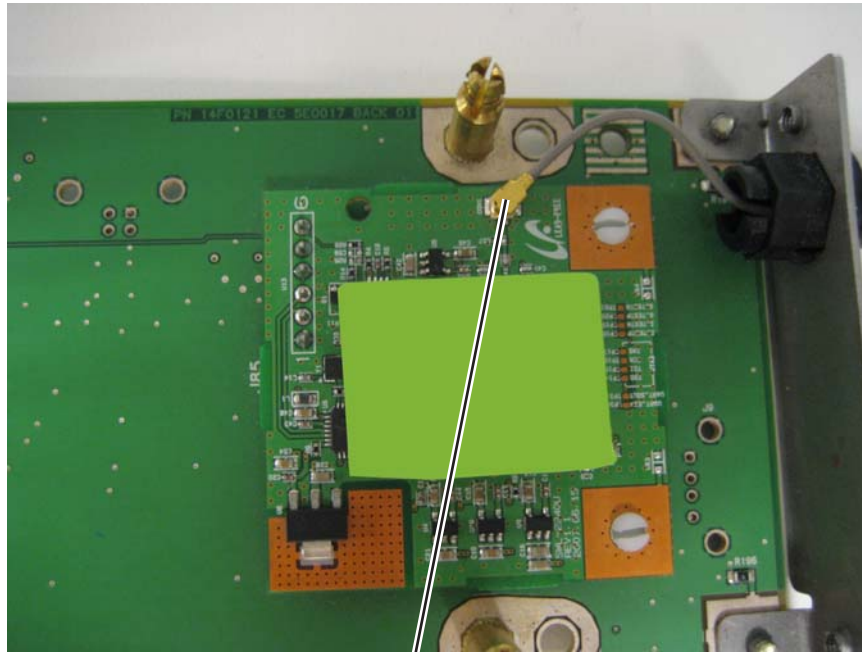

A

3. With pliers, squeeze the inner tabs (B), and pull the antenna out.

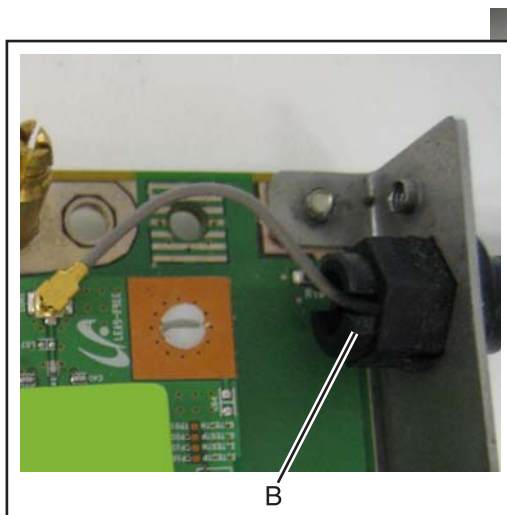

B

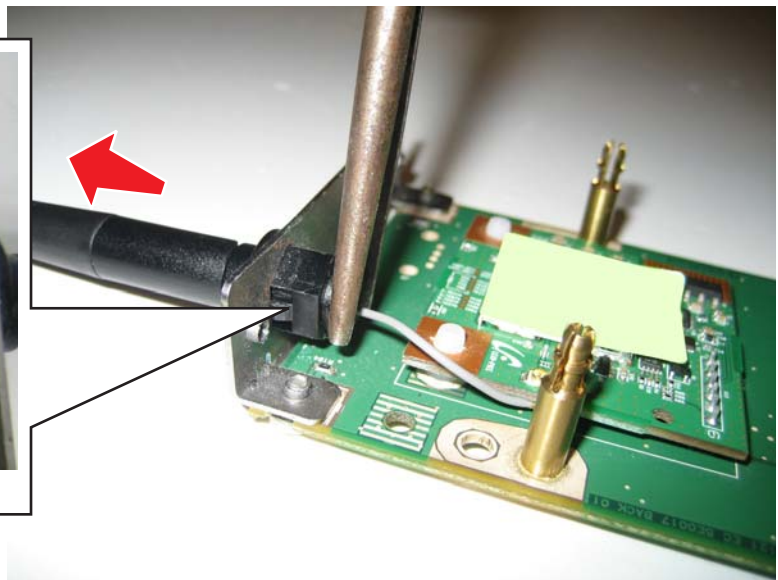

4. Pull the cable through, and remove the antenna with the cable.

Wireless network card removal

1. Remove the rear frame cover. See **“Rear frame cover removal”** on page 4-38.
2. Squeeze the connector (A) to disconnect the wireless cable from the system board at J5.

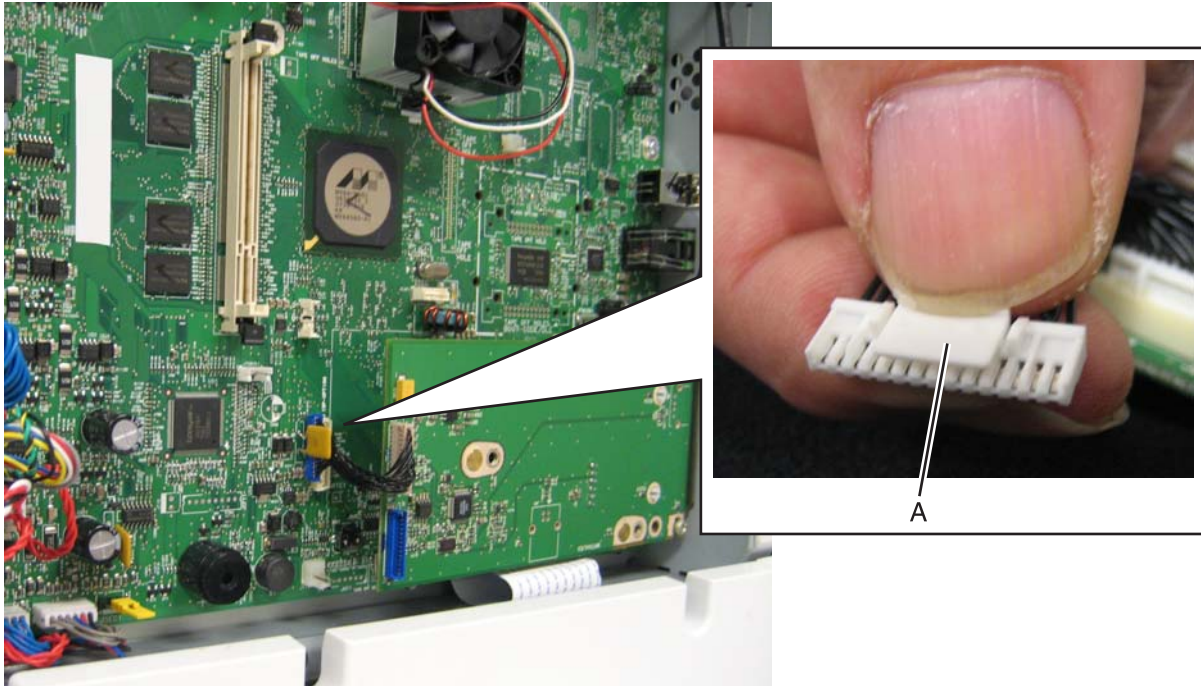

3. Open the left door cover.
4. Remove the two screws (B) that secure the card into place.

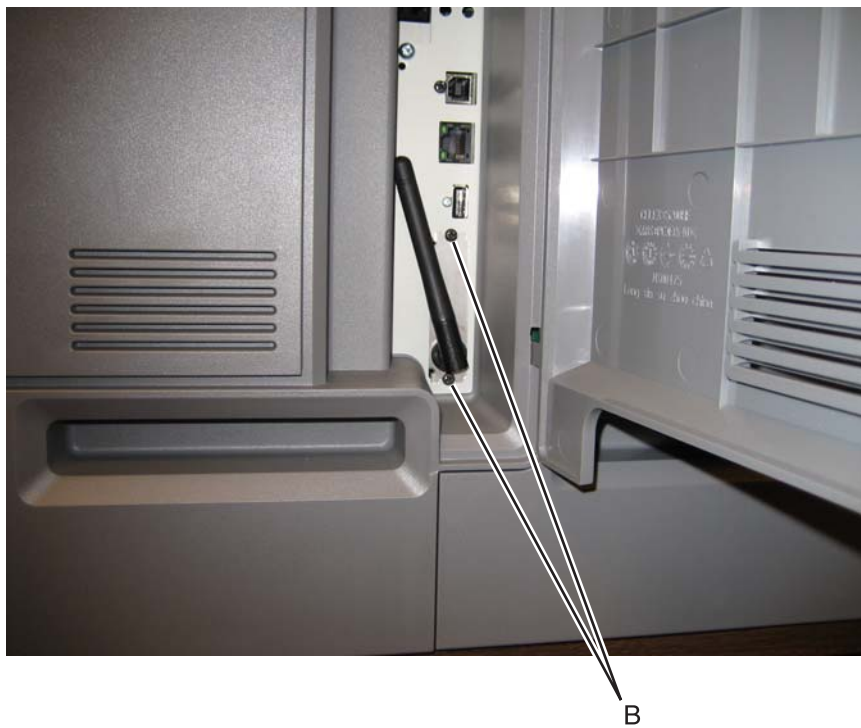

5. Pop the posts (C) on the card from the sockets (holes) in the system board.

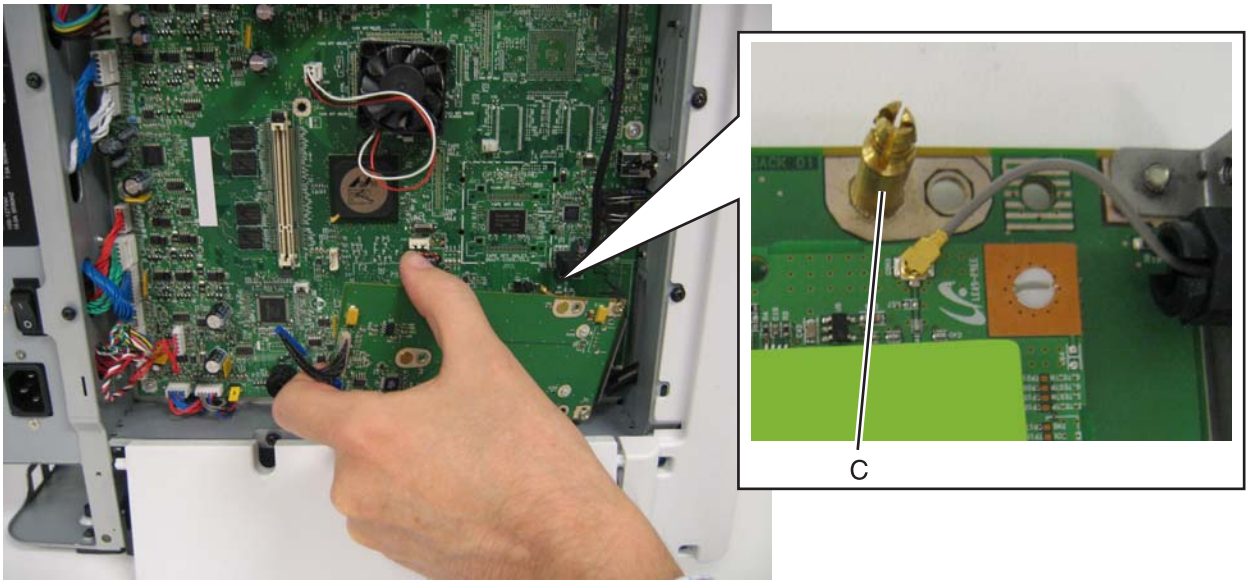

Note: If you are removing the wireless network card to access another part, leave the antenna attached to the card, and you are done. If you need to replace the wireless network card FRU, continue with the next step to remove the separate wireless network antenna FRU.

6. Remove the wireless network antenna. See **“Wireless network antenna removal”** on page 4-187.

Scanner flatbed and automatic document feeder (ADF)

ADF front cover removal

1. Open the ADF front cover.
2. Remove the two screws (A).

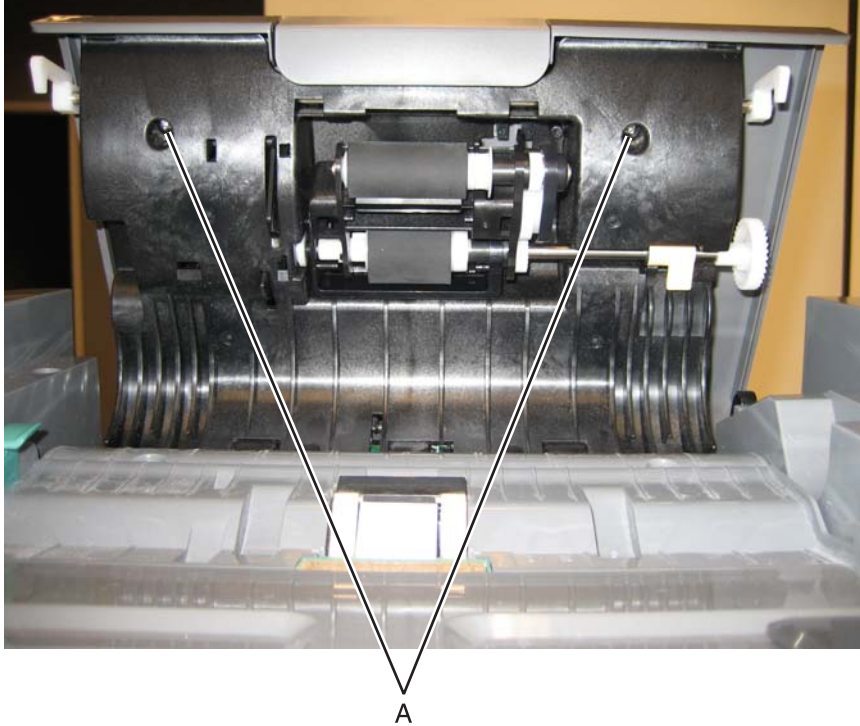

3. Close the ADF front cover.
4. Separate the cover from the ADF case assembly by pressing on the release and cover.



5. Lift the cover from the ADF.



ADF front side cover removal

1. Remove the input tray. See **“Input tray removal”** on page 4-204.
2. Open the ADF front cover.
3. Remove the screw (A).



A

4. Lift the cover to remove.



Installation notes: Insert the tab into the slot, and lower it into place.



ADF handle cover removal

1. Open the ADF.
2. Remove the two screws (A) in the handle cover.



A

3. Remove the handle cover.

ADF motor side cover removal

1. Remove the input tray. See **“Input tray removal” on page 4-204.**
2. Remove the ADF front cover. See **“ADF front cover removal” on page 4-190.**
3. Open the ADF case assembly.
4. Remove the two screws (A).



5. Lift the ADF motor side cover, and disconnect the tray connector (B).

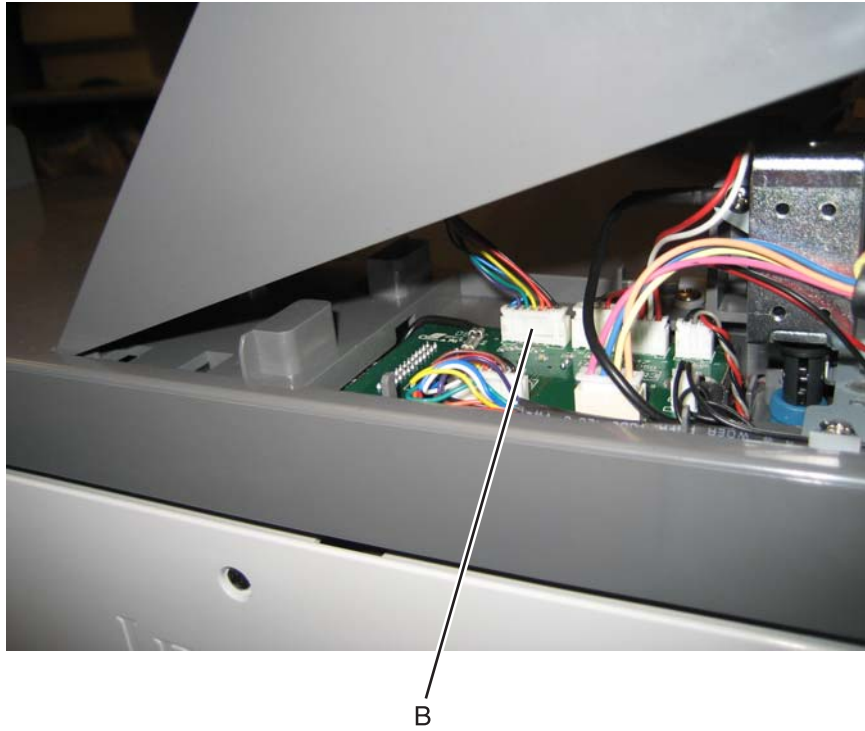

Note: If you are removing the ADF motor side cover to access another part, leave the cable attached, and you are done. If you need to replace the ADF motor side cover FRU, continue with the next step to remove the separate left door cover FRU. Reinstall the cable in the new ADF motor side cover.

6. Gently pull the cable through the hole (C) in the side of the ADF motor side cover.

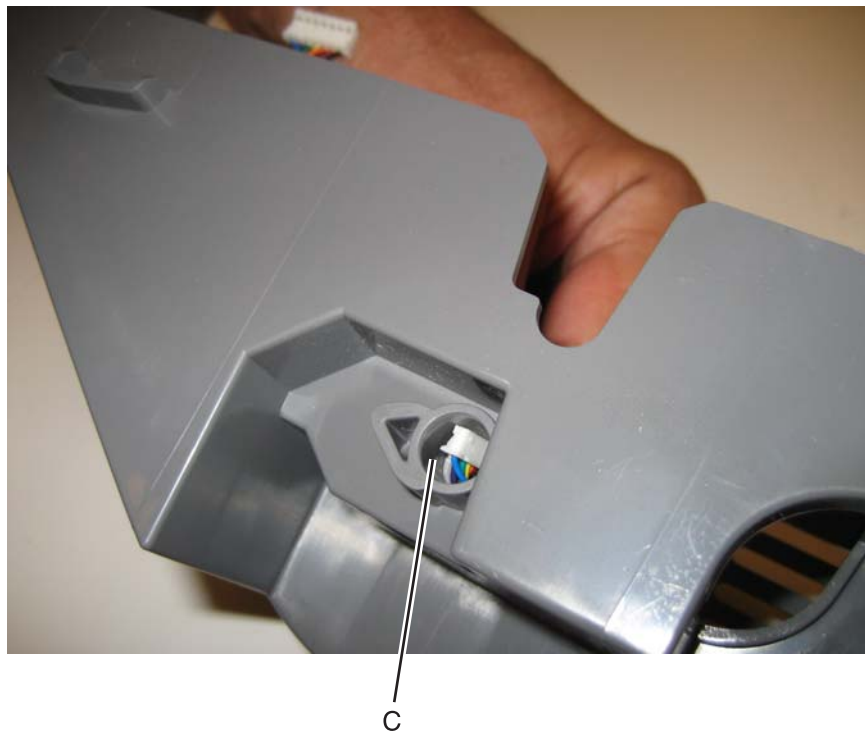

7. Remove the screw (D) to remove the cable from the ADF motor side cover.

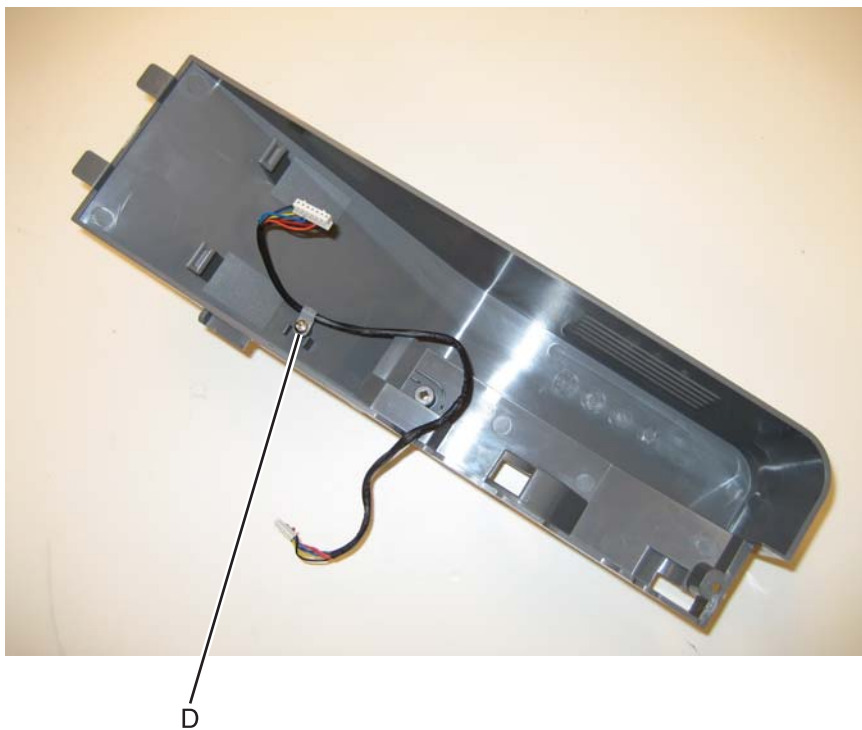

Installation notes:

- Install the cable from the old FRU in the new FRU.
- Be sure to route the cable through the hole. The smaller connector goes through the hole.
- Insert the tab though into the slot, and then lower the ADF motor side cover into place.

ADF upper case cover removal

1. Open the ADF cover.
2. Remove the two screws (A).

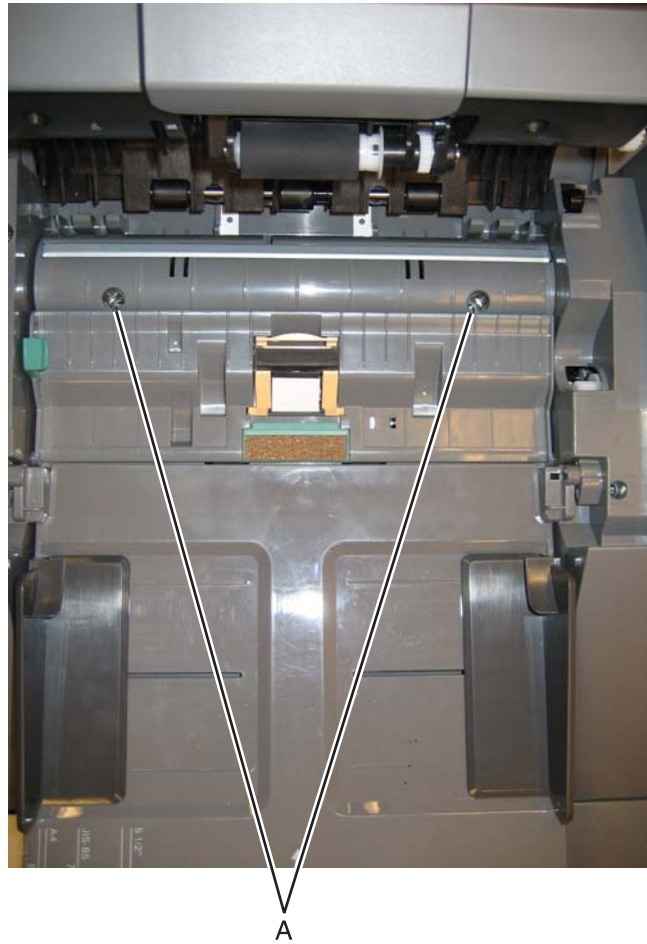

3. Lift the ADF upper case cover up to access the ground screw, and remove the ground screw (B).

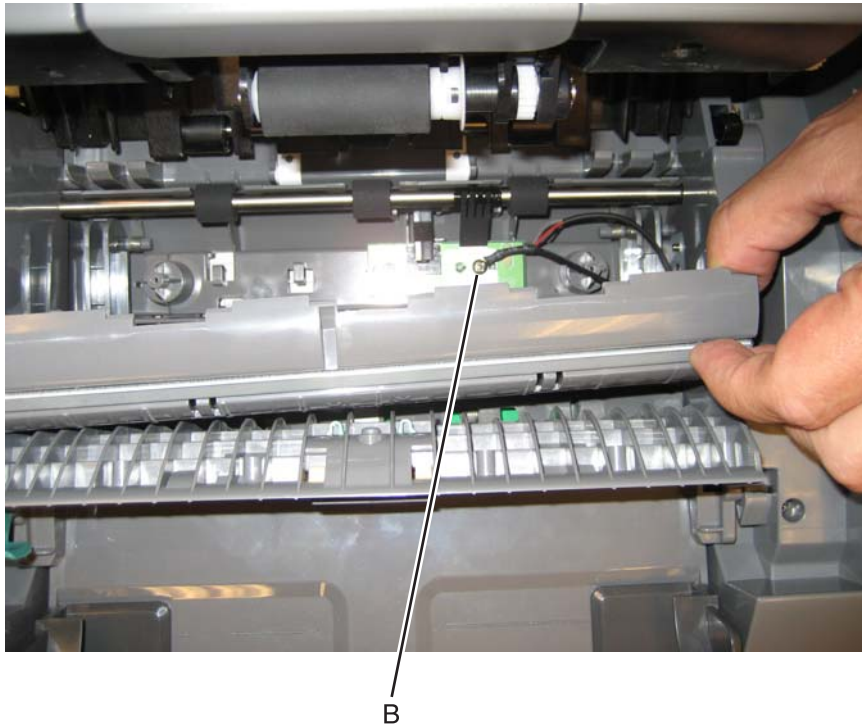

Note: If you are removing the ADF upper case cover to access another part, leave the cable attached, and you are done. If you need to replace the ADF upper case cover, continue with the next step to remove the separate cable.

4. Remove the screw (C) holding the ground cable on the ADF upper case cover. The cable is not part of the new FRU, and is reinstalled on the new FRU.

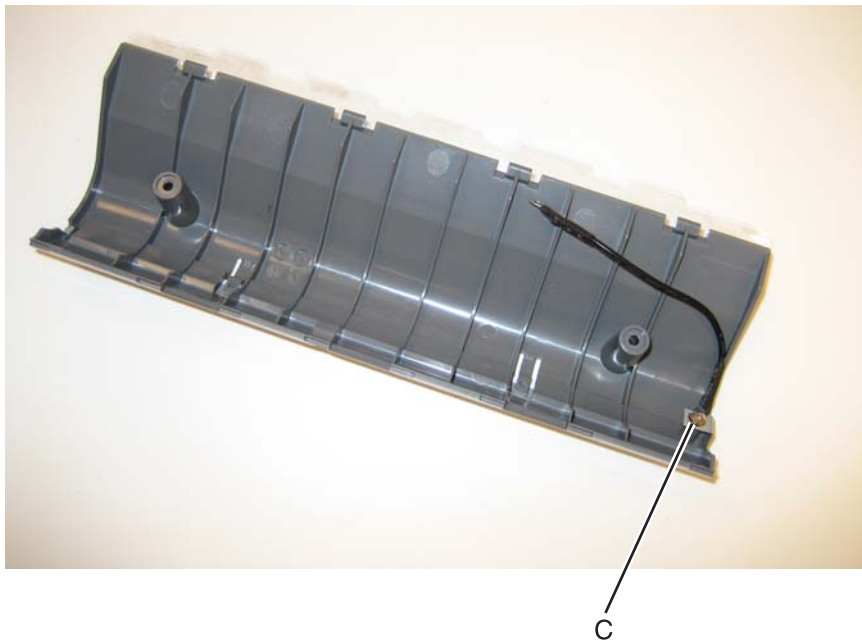

Flatbed cave LED card and cover removal

The flatbed cave LED card and the flatbed cave LED cover are separate FRUs. The removal for each is the same.

1. Remove the screw (A).



A

2. Pull the assembly down.
3. Disconnect the cable (B).

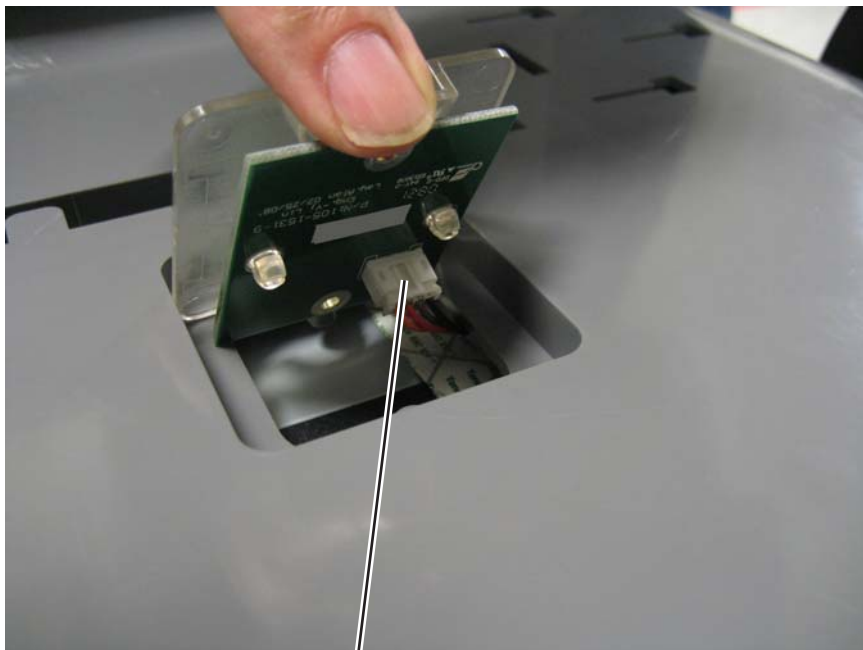

B

4. Pinch each of the two clear posts (C), separate the flatbed cave LED cover from the flatbed cave LED card.

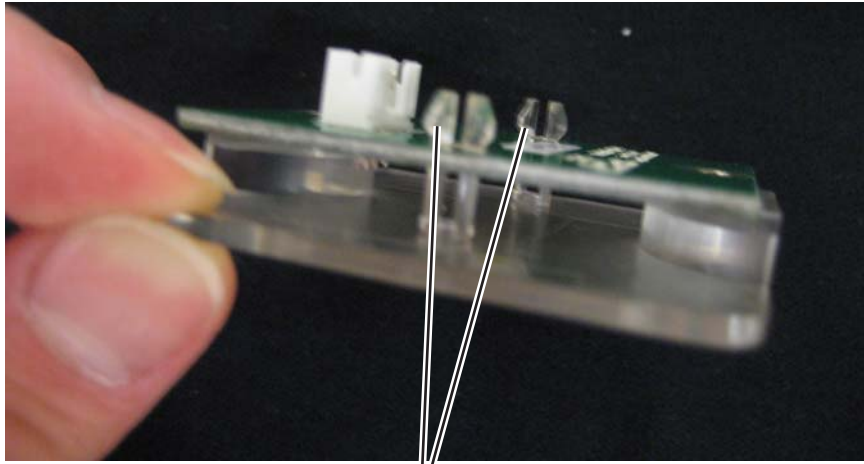

C

5. Separate the FRU you need to replace.

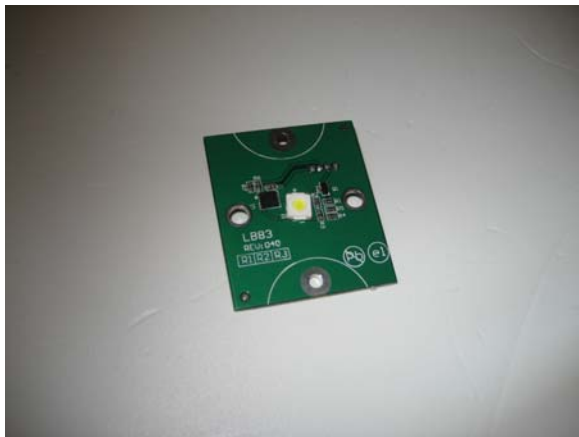

Flatbed with glass cover removal

1. Remove the ADF. See **“ADF removal (entire)”** on page 4-210.
2. Disconnect the two cables (A).

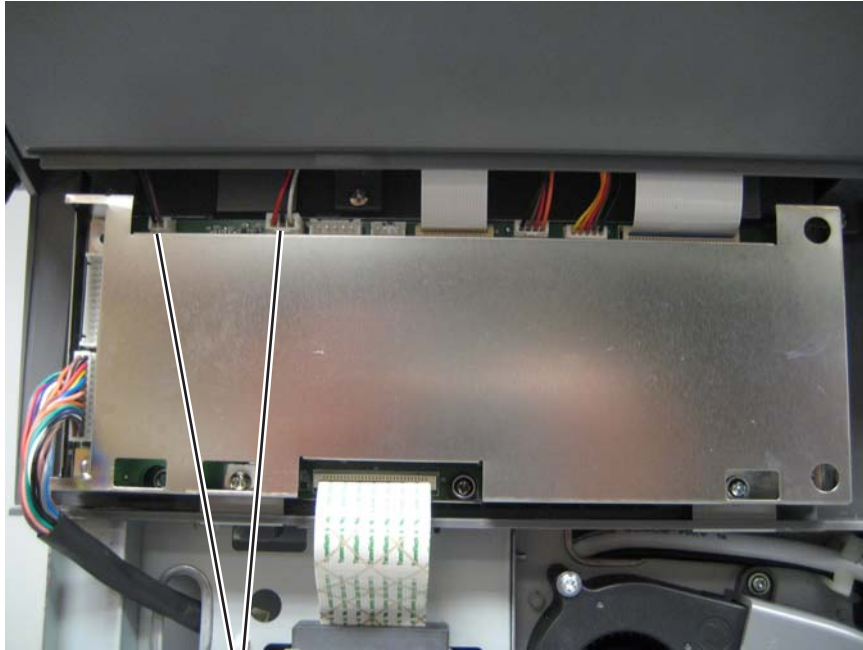

A

3. Remove the scanner left cover. See **“Scanner left cover removal”** on page 4-206.
4. Remove the scanner right cover. See **“Scanner right cover removal”** on page 4-208.
5. Remove the four screws (B).



B

6. Remove the four screws (C) from the right and left sides.



C

C

7. Remove the two screws (D) from the top.



D

D

8. Lift up and extract the two cables (E) through the frame.

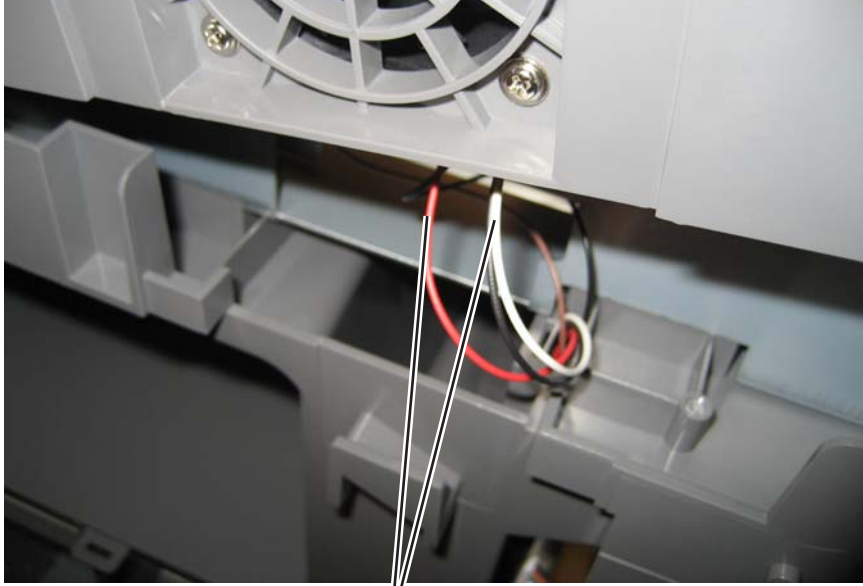

E

9. Remove the flatbed with glass cover.



Input tray removal

1. Lift the input tray.
2. Remove the screw (A) securing the cable cover.



A

3. Disconnect the cable connector (B).



B

4. Lift the left front side, and ease the rear right edge out.

5. Disengage the cable from the channel, and remove the tray.
Note: Observe the routing for re-installation.

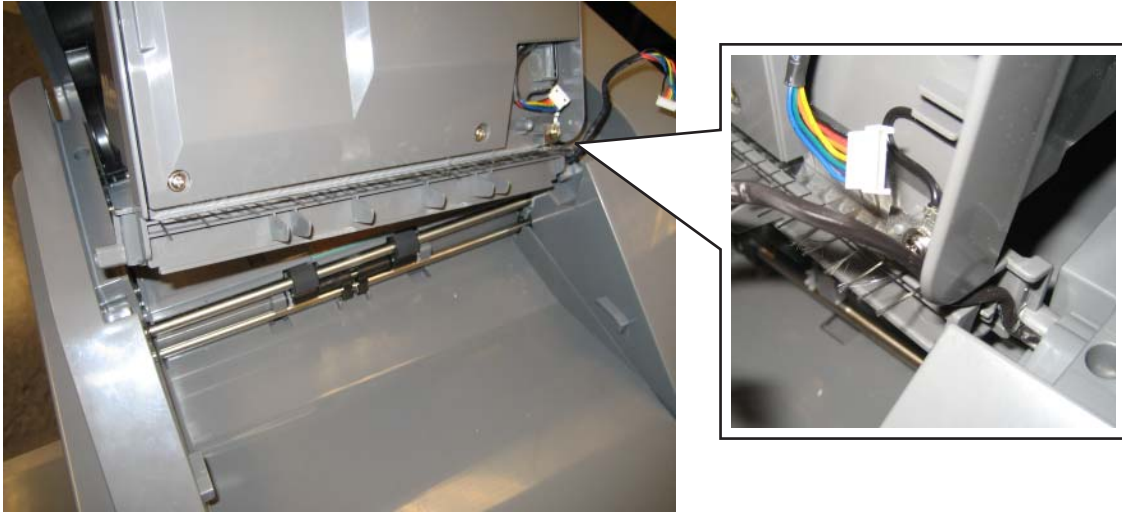

Scanner front cover removal

1. Open the ADF.
2. Grasp the front cover and the top right, and pull to remove the scanner front cover.



Scanner left cover removal

1. Remove the scanner front cover. See **“Scanner front cover removal”** on page 4-205.
2. Remove the left cover. See **“Left cover removal”** on page 4-23.
3. Remove the three screws (A).

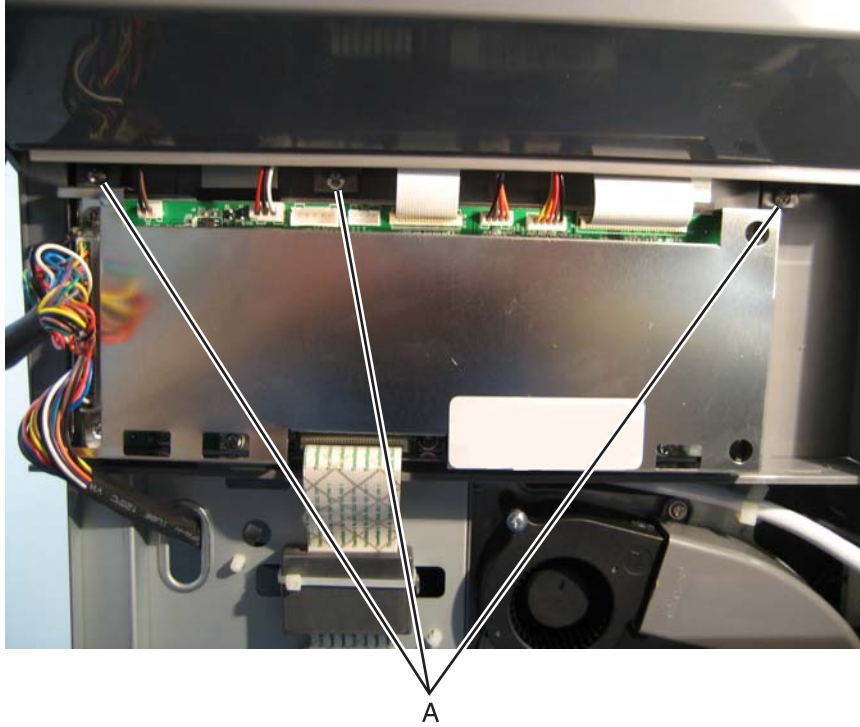

4. Pull the bottom out, and slide it toward the front.



5. Lift the left cover away.

Scanner rear cover removal

1. Remove the six screws (A).

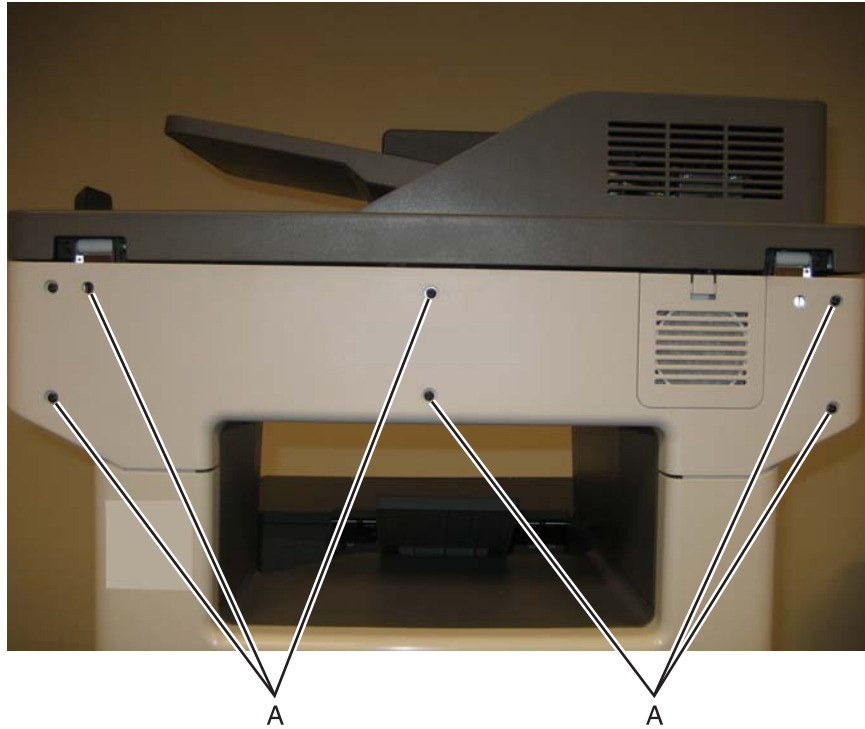

2. Remove the scanner rear cover.
Note: Make sure the flatbed filter does not get lost.

Scanner right cover removal

1. Remove the scanner front cover. See **“Scanner front cover removal”** on page 4-205.
2. Remove the right cover. See **“Right cover removal”** on page 4-39.
3. Remove the screw (A).



A

4. Slide the cover toward the front of the multifunction printer.



5. Grasp the cover on the lower right, and pull up.



ADF removal (entire)

1. Remove the left cover. See **“Left cover removal” on page 4-23.**
2. Remove the ground screw (A) secured to the MDC card.
3. Disconnect the cable (B).



A

B

4. Remove the scanner rear cover. See **“Scanner rear cover removal” on page 4-207**

5. Remove the screw (C) that secures the ground cable.
6. Remove the cable from the cable restraint (D).

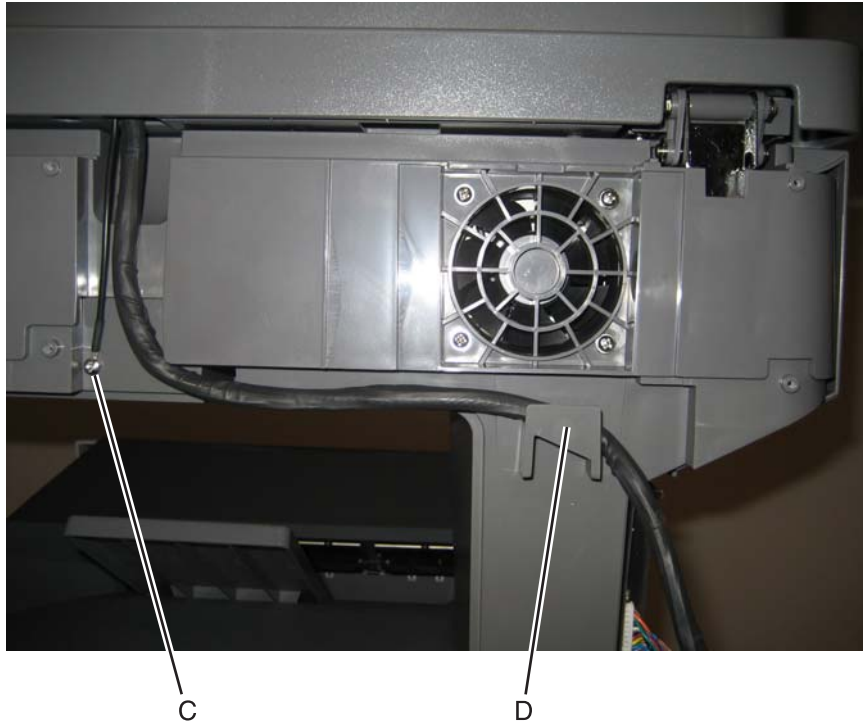

7. Lift the ADF until it has resistance, press the release tabs (D), and complete removing the ADF.
Note: It may be easier to release the tab closest to the left side first.



Installation note:

Be sure to attach the ground cable to the screw (see step 6 above).

Warning: Whenever you replace the ADF (entire), the flatbed scanner, or the MDC card, perform the **“Scanner Manual Registration”** in Configuration menu.

To enter Config Menu:

1. Turn off the multifunction printer.
2. Press and hold **2** and **6**.



3. Turn on the MFP.
4. Release the buttons when the progress bar displays.

ADF case assembly removal

1. Remove the ADF front cover. See **“ADF front cover removal”** on page 4-190.
2. Disconnect the sensor cable (A).

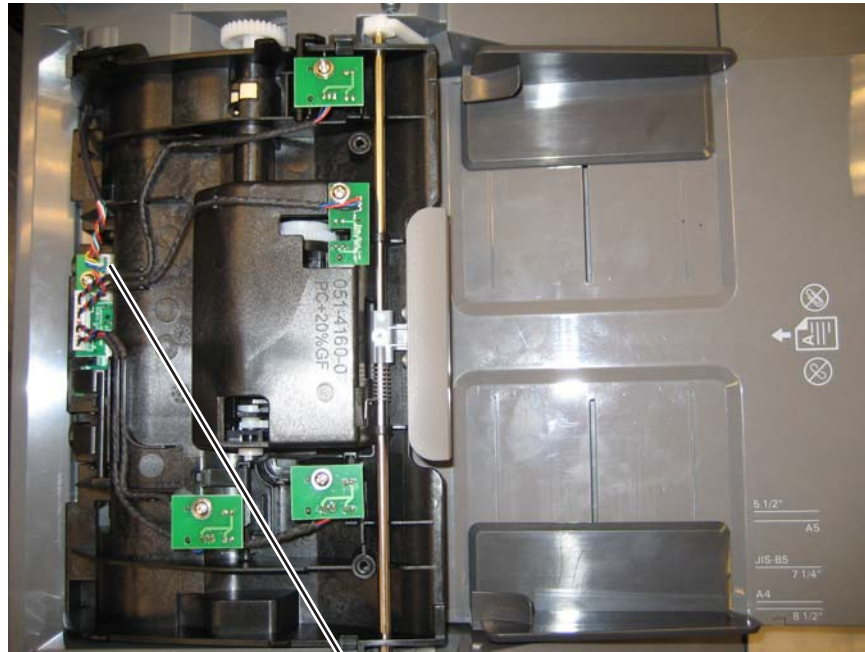

A

3. Rotate the ADF case assembly until the flattened shaft ends come out of the opening.

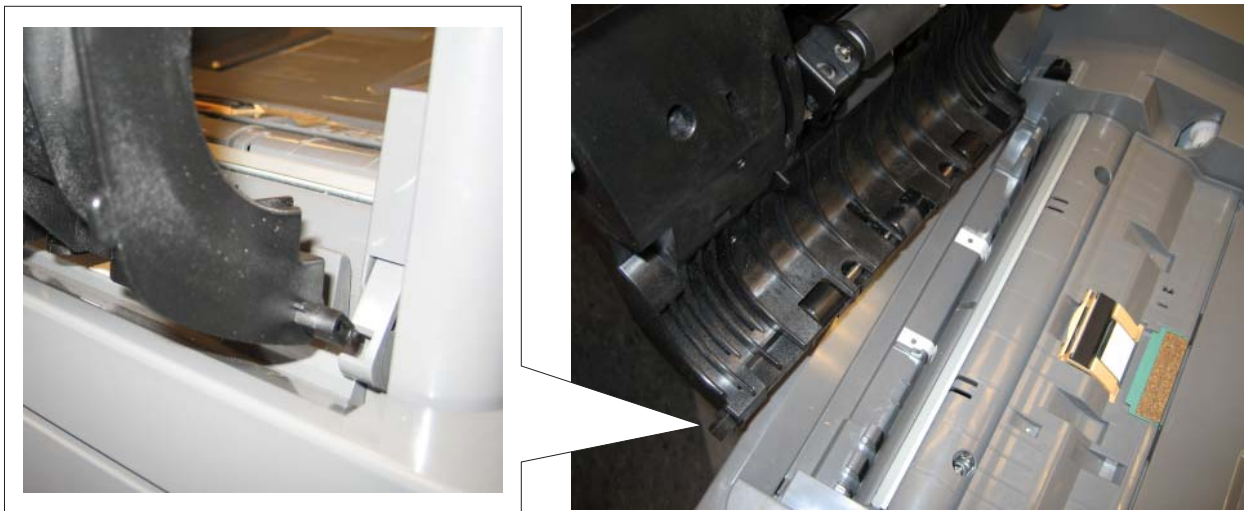

4. Remove the sensor cable from the narrow retainer by untwisting the cable wires and easing them out individually.



5. Remove the ADF case assembly.

ADF closed cover flag removal

1. Remove the ADF front cover. See **“ADF front cover removal”** on page 4-190.
2. Remove the screw (A).
3. Lift the sensor (B) out of the way.



A

B

4. Remove the closed cover flag (C).



C

ADF exit sensor (with cable) removal

1. Remove the ADF motor side cover. See **“ADF motor side cover removal”** on page 4-194.
2. Disconnect the output sensor cable.

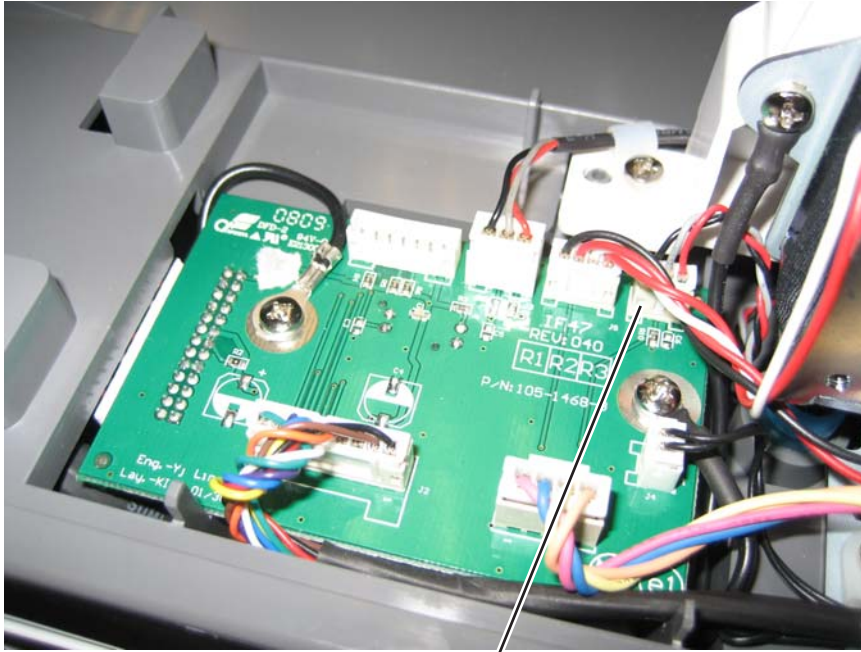

A

3. Push the cable and connector through the opening (B) in the ADF frame.

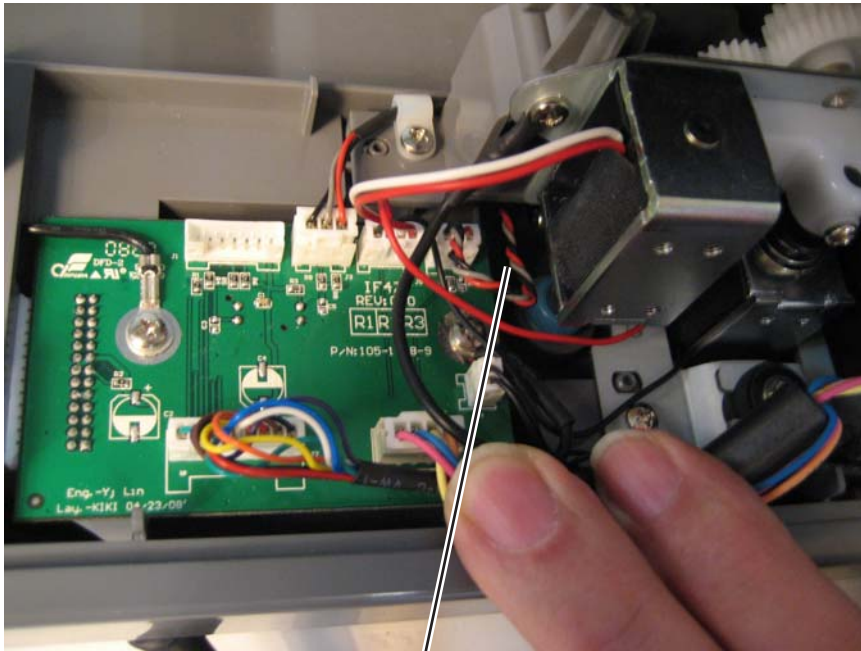

B

4. Remove the ADF pressure plate cover. See **“ADF pressure plate cover removal”** on page 4-226
5. Use a flat-blade screwdriver to open the latch (C) the output sensor card.



6. Remove the ADF exit sensor and cable.

ADF hinge (left and right) removal

The hinges are removed in a similar manner. Only one hinge is shown in this removal.

1. Remove the ADF. See “**ADF removal (entire)**” on page 4-210.
2. Turn the ADF over.
3. Remove the four screws (A) of the hinge you want to remove.



4. Remove the hinge.

ADF motor gear train removal

1. Remove the ADF motor side cover. See **"ADF motor side cover removal"** on page 4-194.
2. Disconnect the three connectors (A).

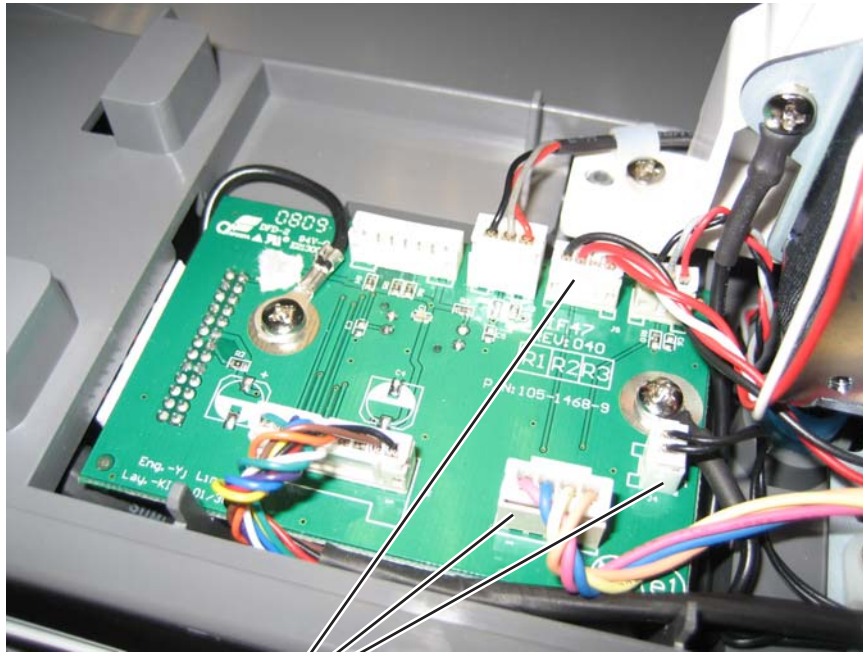

A

3. Remove the two screws (B), and the two ground screw (C).

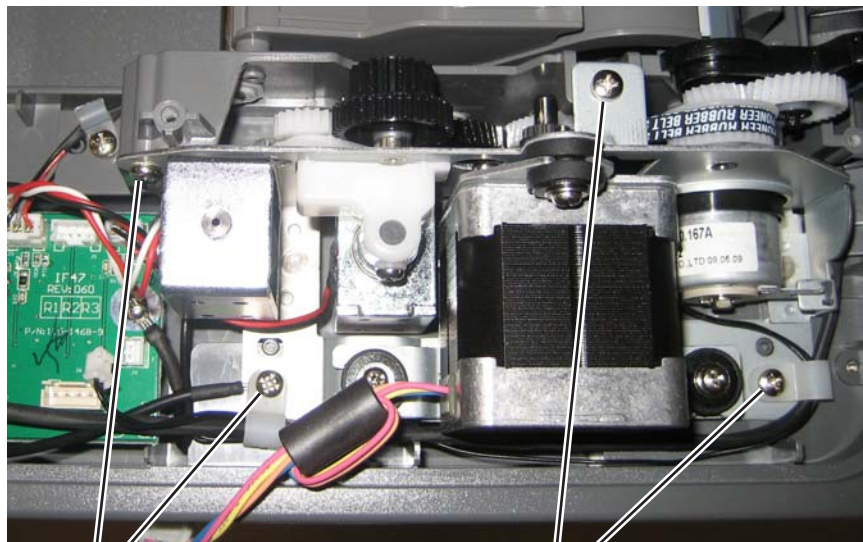

C

B

4. Remove the ADF motor gear train.
Note: Be sure to note the routing of the clutch motor cable.

Installation notes:

1. Place the ADF motor gear train assembly over the clutch motor, and make sure the clutch motor cable (A) is through the housing.

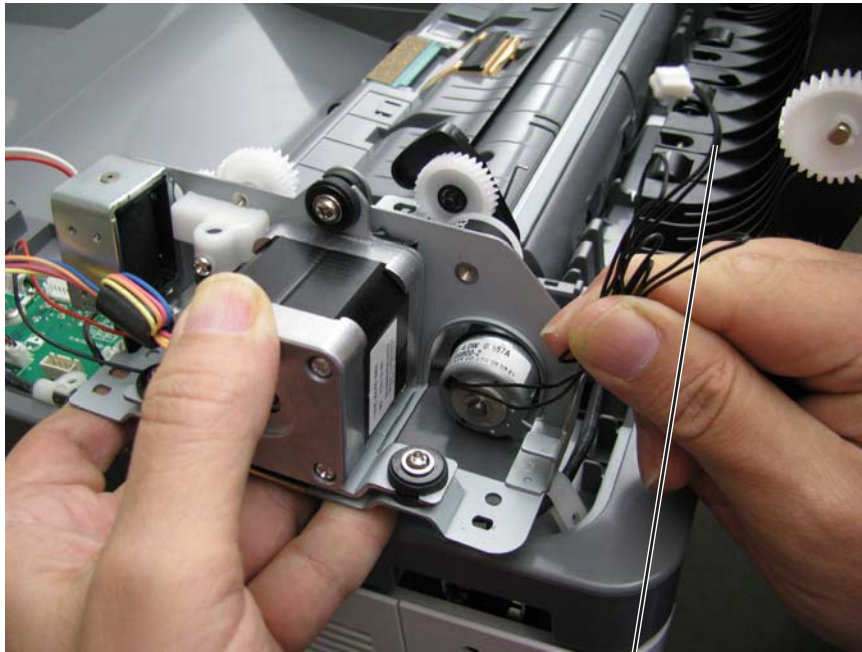

A

2. Make sure the fork of the clutch assembly (B) is up, and the gear (C) is up.
3. Slide the left side of the ADF motor gear train assembly into place, and then press down on the lever (D) with your finger to make sure the arm of the motor gear assembly slides in **below** the ledge.

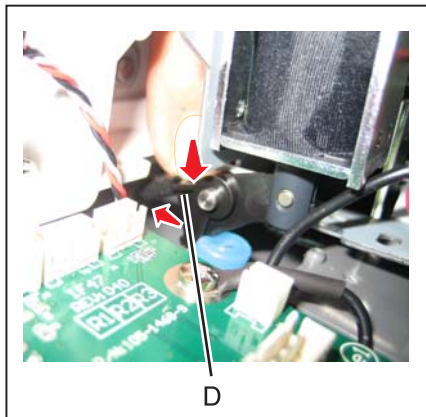

D

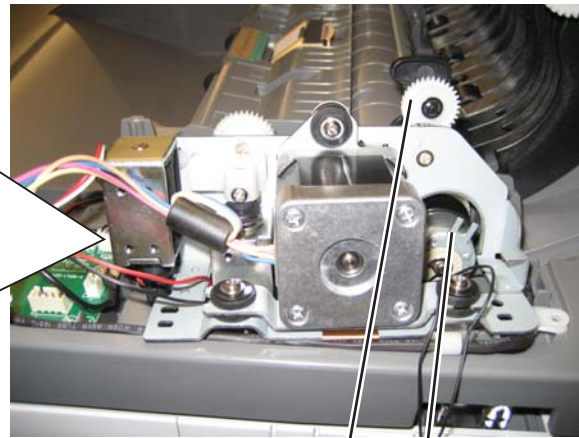

C

B

- Slide the right side of the ADF motor gear train assembly into place, making sure that the fork (E) engages the plate (F).

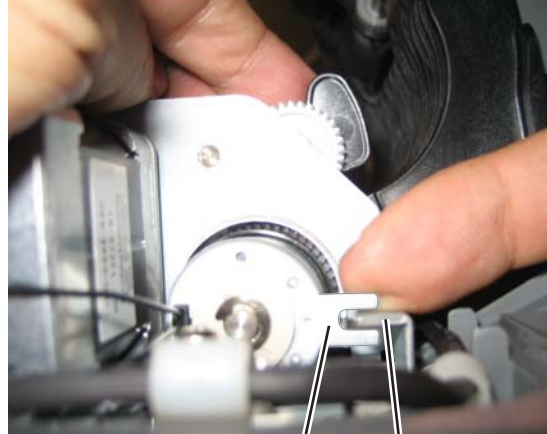
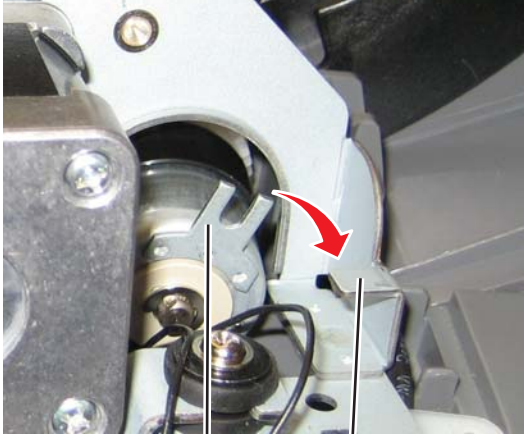

- Rotate the gear arm (G) down until the spring (H) latches into the frame.



6. Route the clutch assembly cable through the cable retainers (J).
7. Replace the four screws (K), making sure that the ground cable (L) is attached to the indicated screw.

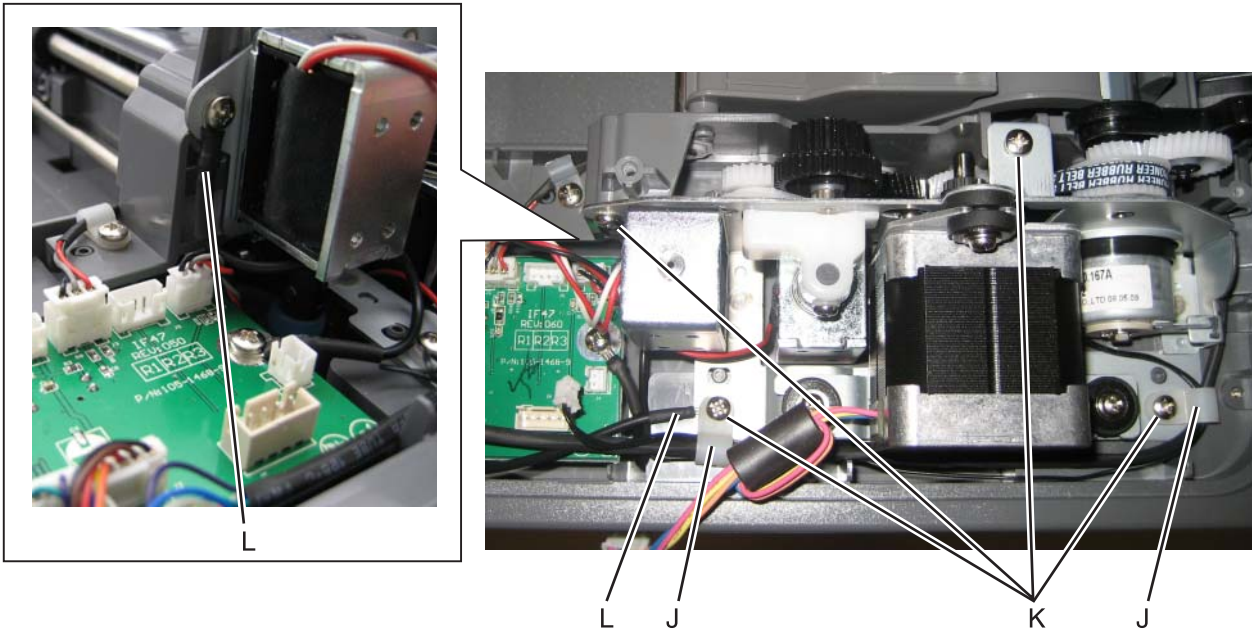

8. Reconnect the cables.
9. Replace the covers and ADF input tray.

ADF paper stop removal

Pull the paper stop all the way out, and slide out.



ADF pick pad removal

1. Open the ADF cover.
2. Lift the pick pad (A), and remove the pad.

Note: Although the spring is not part of the ADF pick pad FRU, be careful not to lose the spring.

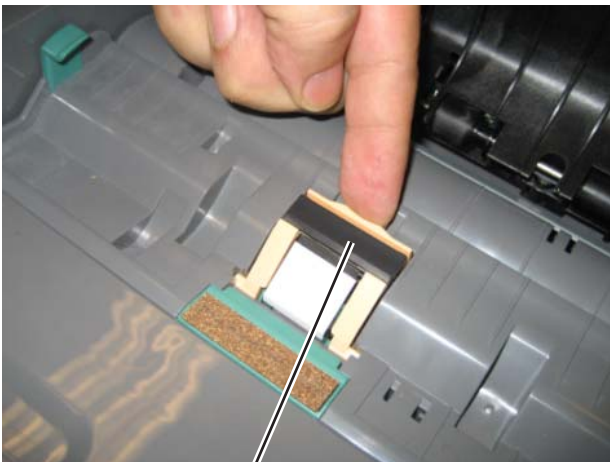

A

B

ADF pick pad spring removal

1. Remove the ADF pick pad. See **“ADF pick pad removal”** on page 4-223.
2. Lift out the spring (A).



A

ADF pick roller assembly removal

1. Open the ADF.
2. Rotate the locking lever (A), and remove the ADF pick roller assembly.



A



Installation notes:

1. Install the left side of the ADF pick roller assembly first.
2. Push the assembly flat into the ADF, while turning the gear on the right (A).



A

3. When the assembly *clicks* into position, then rotate the locking lever until it is flat against the ADF.



B

4. Verify that the installation was correct by pressing the ADF pick roller into the ADF door, then pulling the door down until the ADF pick roller assembly smoothly falls forward, without falling out.



ADF pressure plate cover removal

1. Open the ADF.
2. Use a flatblade screwdriver to release the tabs.

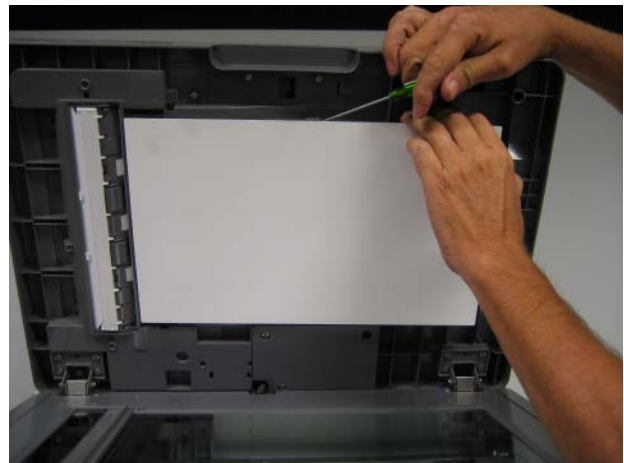
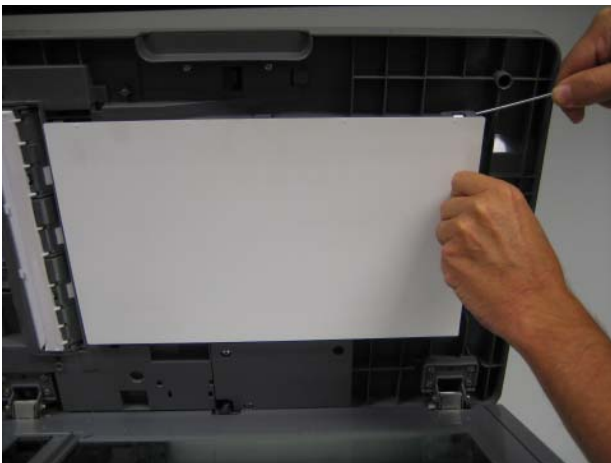

3. Pull the pressure plate cover down, and remove it.



Installation note:

Set the pressure plate face down over the glass of the flatbed, and close the ADF. The ADF pressure pad will *snap* into place as the ADF is lowered.

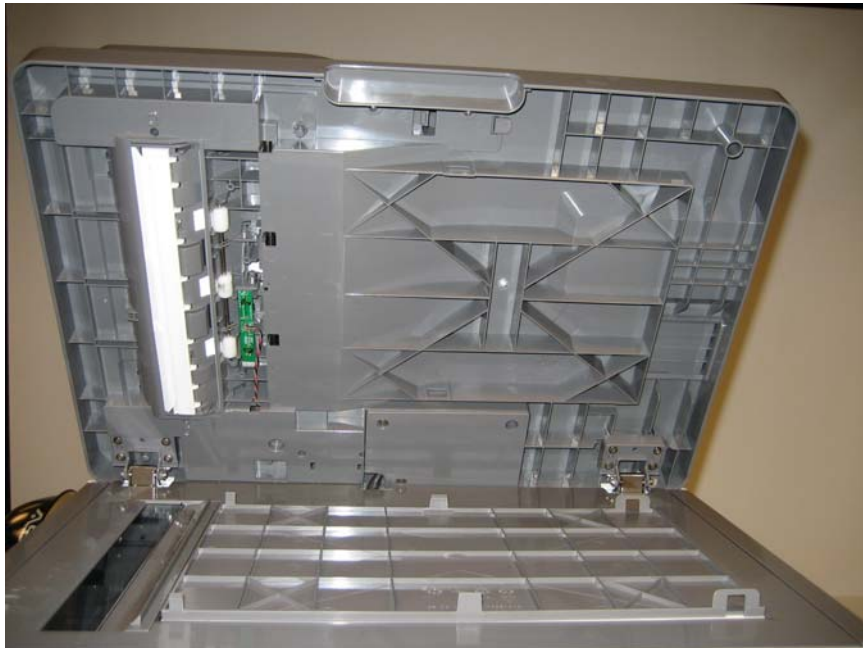

ADF separator pad removal

1. Open the ADF cover.
2. Lift the ADF separator pad (A), and remove the pad.

Note: Cover the separator pad with your other hand to prevent the pad from flying away and getting lost or hitting someone.

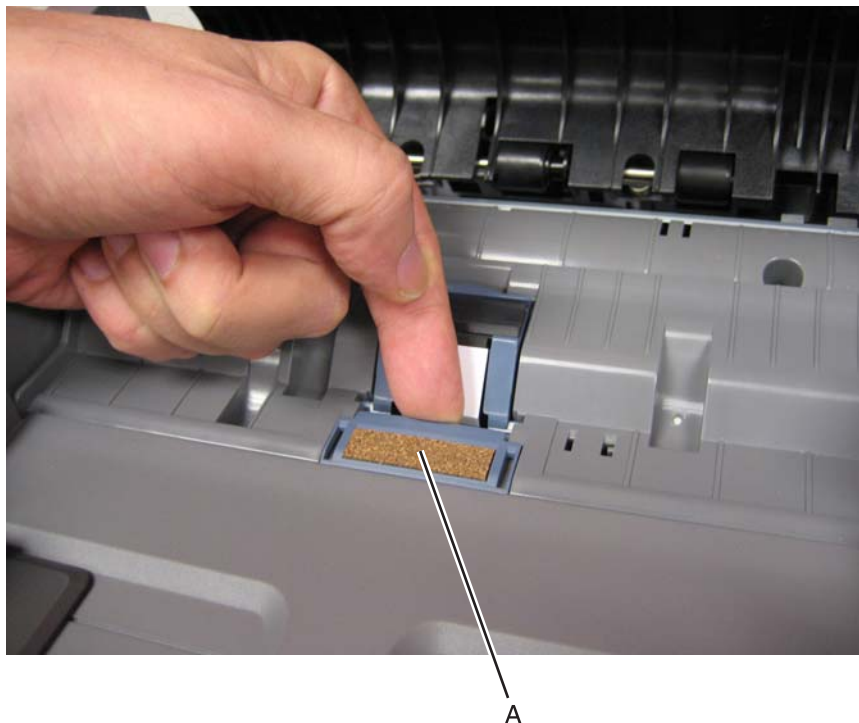

Carriage transport belt with clip removal

1. Remove the flatbed CCD carrier module. See **“Flatbed CCD carrier module removal”** on page 4-235.
2. Remove the two screws (A) on either end of the carriage transport belt.



A



A

3. Remove the cable from the posts.

Installation notes:

- Be sure to route the carriage transport belt correctly.

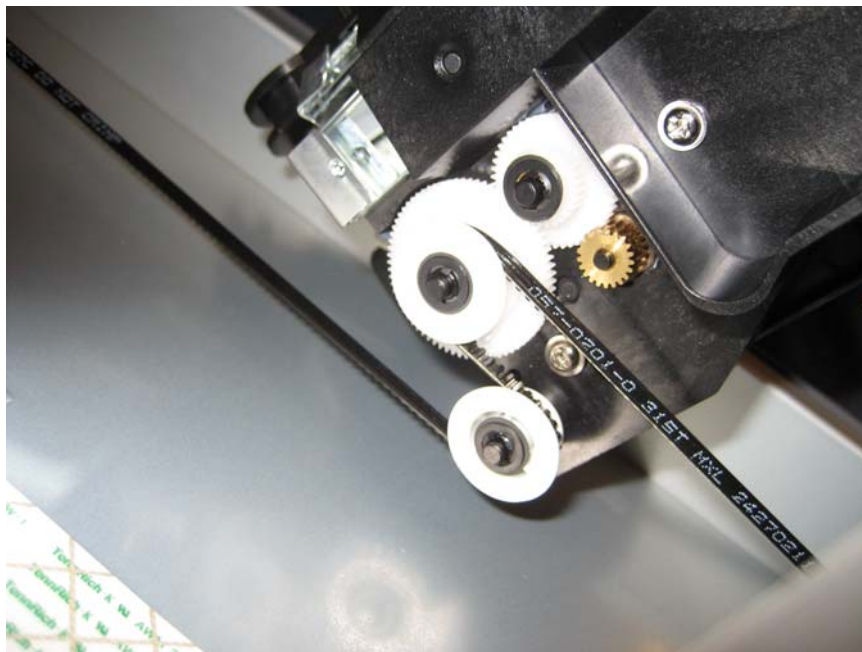

- Be sure to face the toothed edge (A) on the cable as shown.

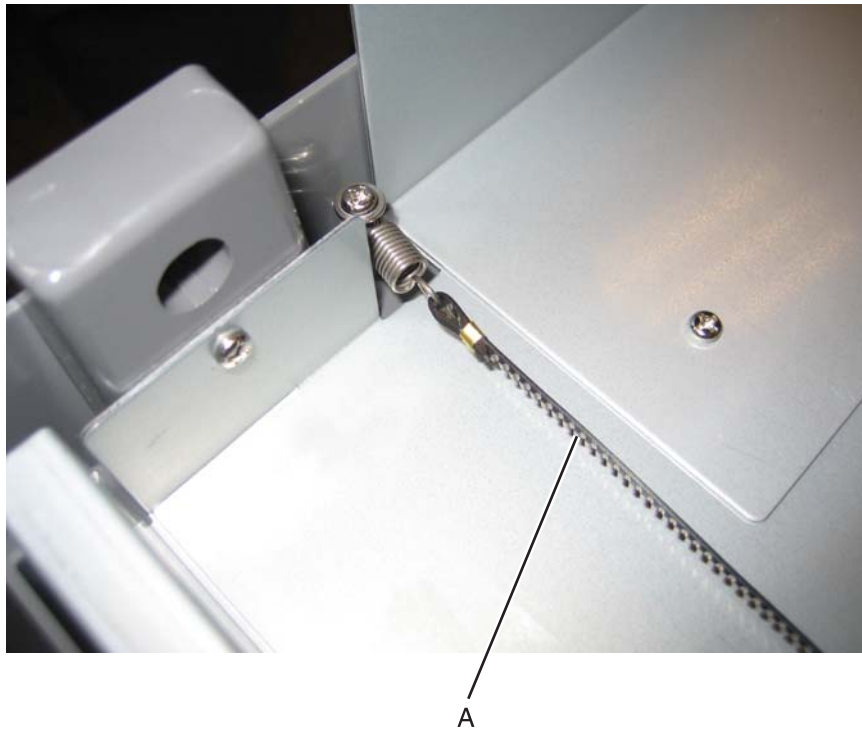

ESD brush removal

1. Remove the ADF upper case cover. See **“ADF upper case cover removal”** on page 4-197.
2. Gently pry the brush off the two posts with a flat-bladed screwdriver.
Note: One post firmly holds the brush, and the other post is an alignment guide.

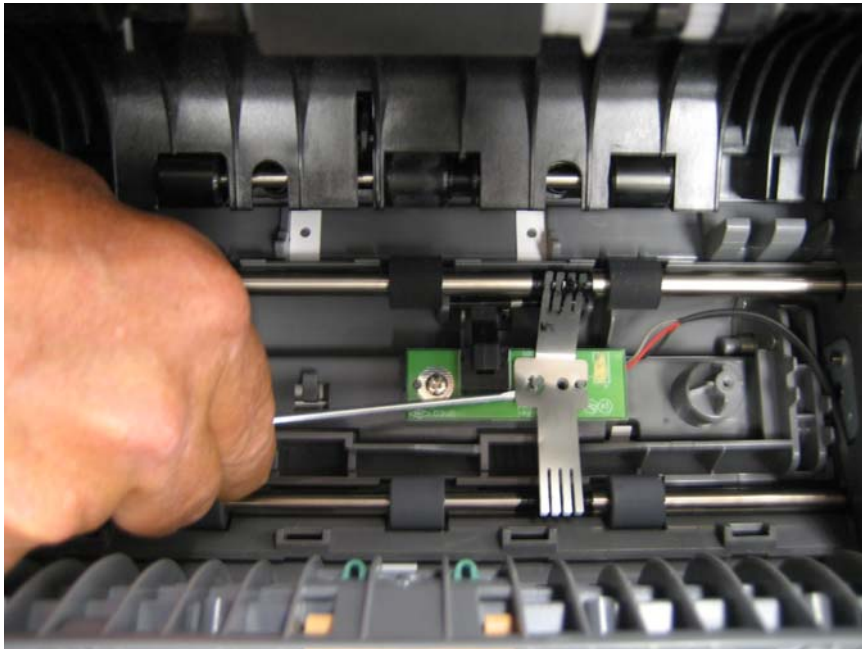

Installation note: Be sure to *snap* the post securely in position.

Flatbed air filter removal

1. Press the tab (A) and remove the filter door cover.



2. Remove the filter.



Flatbed CCD lamp assembly removal



1. Remove the flatbed with glass cover. See **“Flatbed with glass cover removal”** on page 4-201.
2. Remove the three screws (A).

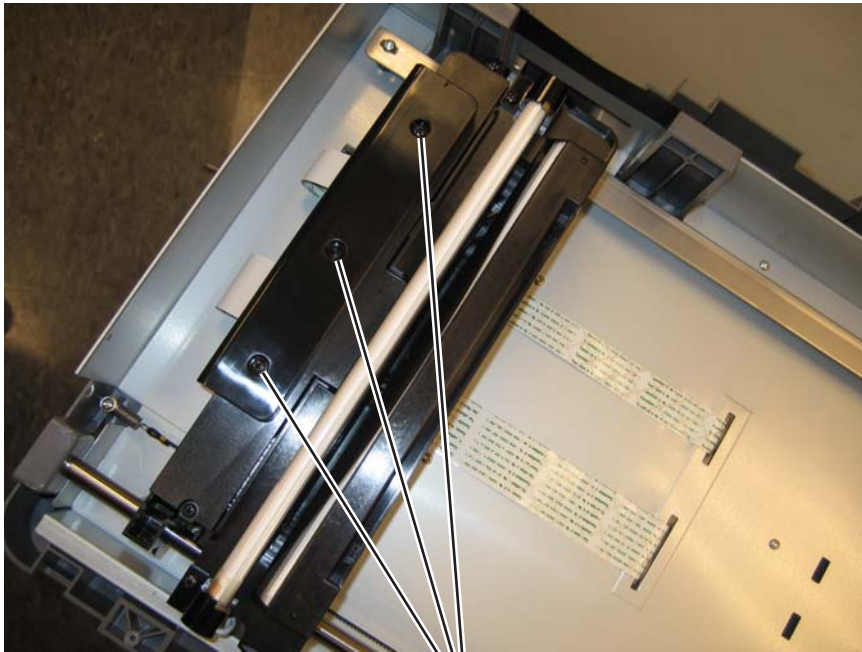

A

3. Lift the cover (B) and pull it back.

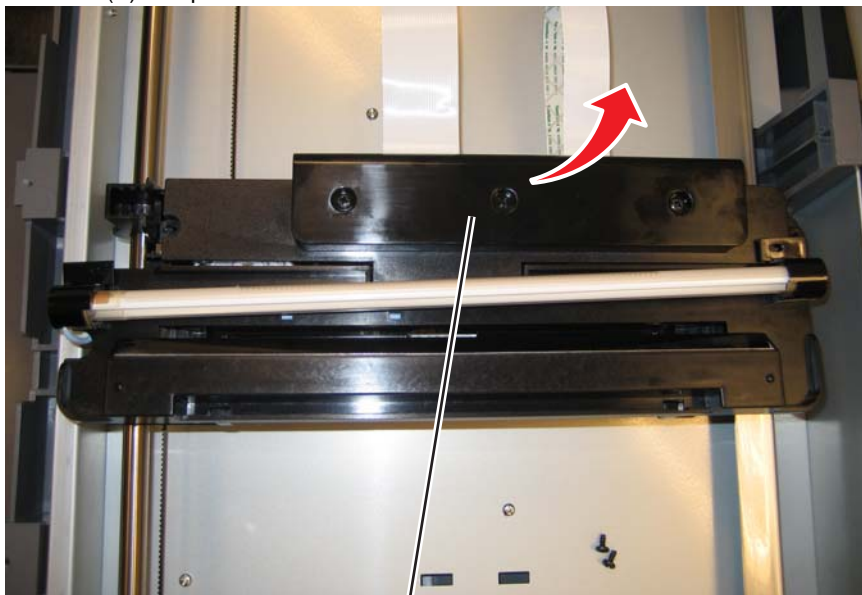

B

4. Release the two latches (C).



C

5. Rotate the lamp assembly, and disconnect the cable (D).

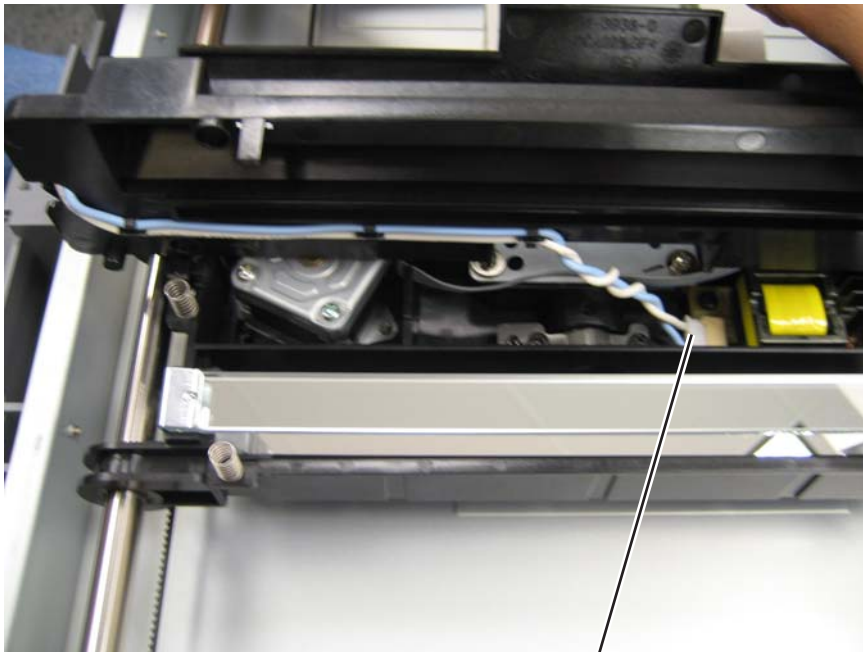

D

Warning: Do not touch the lamp with your hand. Hold it only by the ends, as shown.



6. Remove the lamp assembly.

Installation notes:

- Make sure the four springs (A) are in place.

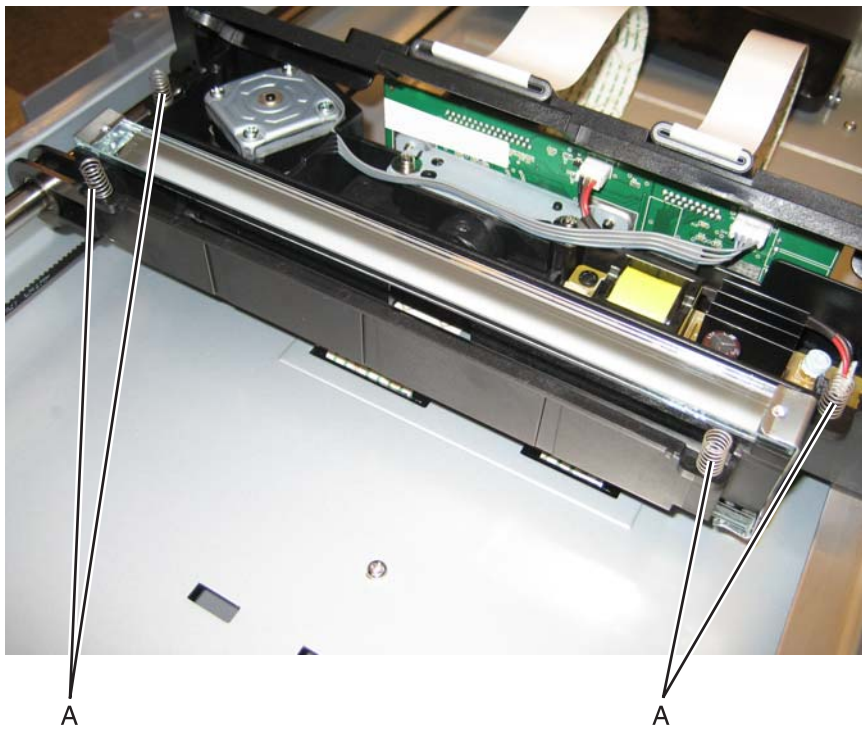

Flatbed CCD carrier module removal

1. Remove the flatbed with glass cover. See **"Flatbed with glass cover removal"** on page 4-201.
2. Remove the two screws (A), and remove the cover.

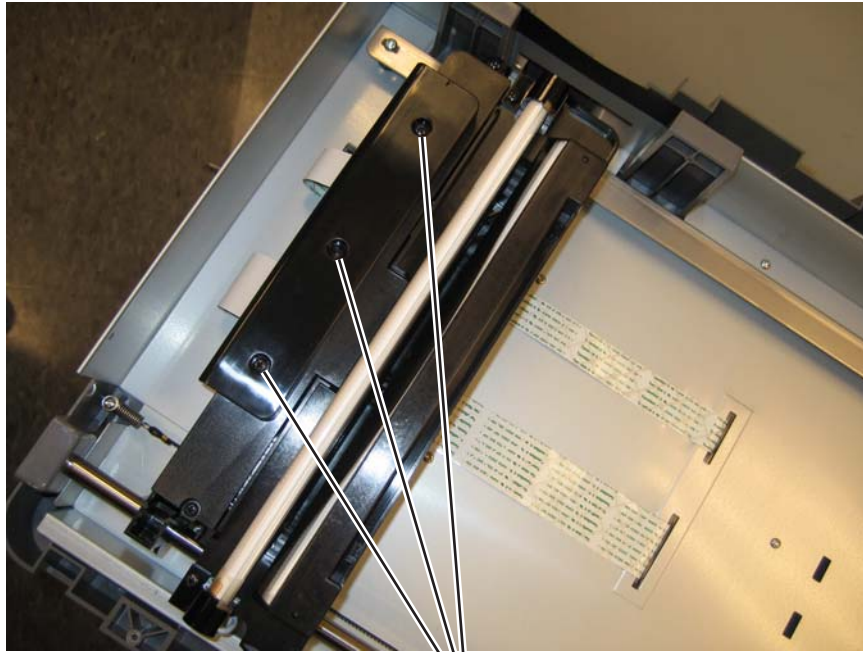

A

3. Disconnect the two CCD cables (B).

Warning: Be careful disconnecting and reconnecting the ribbon cables. Ribbon cables can be damaged easily and should be handled carefully.

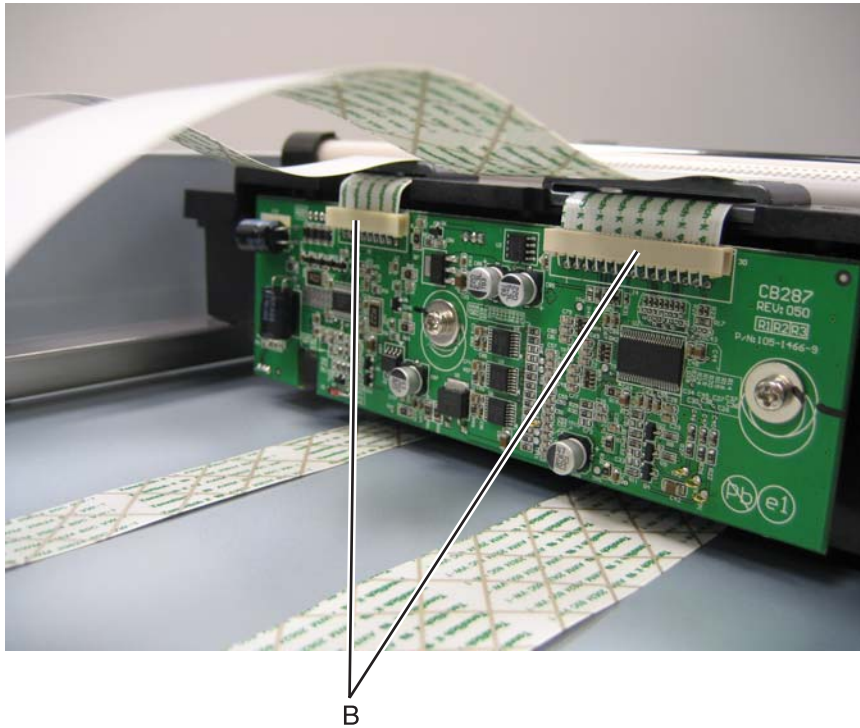

4. Loosen the ground screw (C), and remove the screw (D).

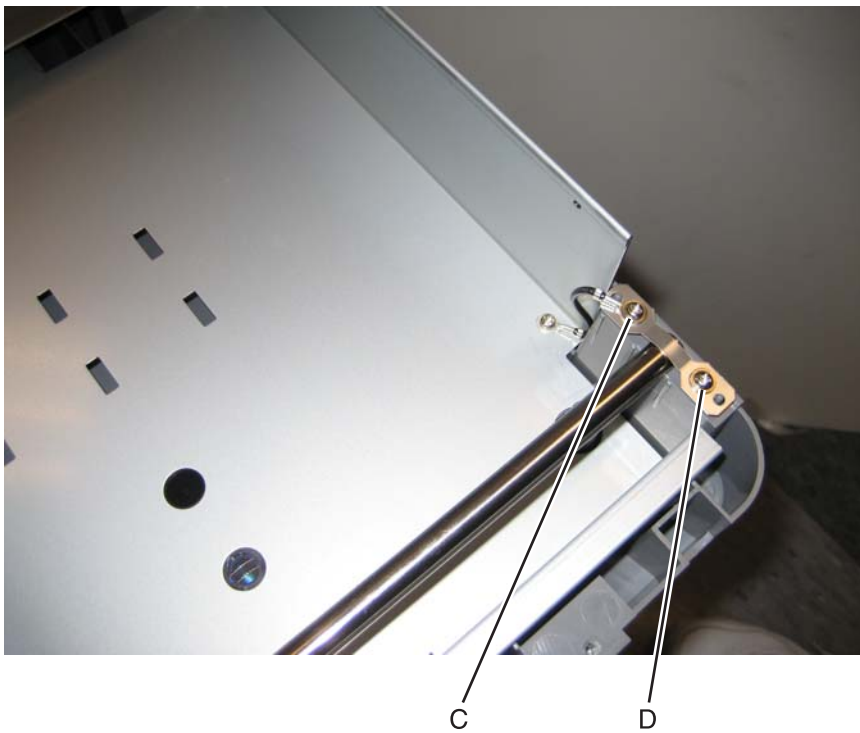

5. Rotate the clip (E).

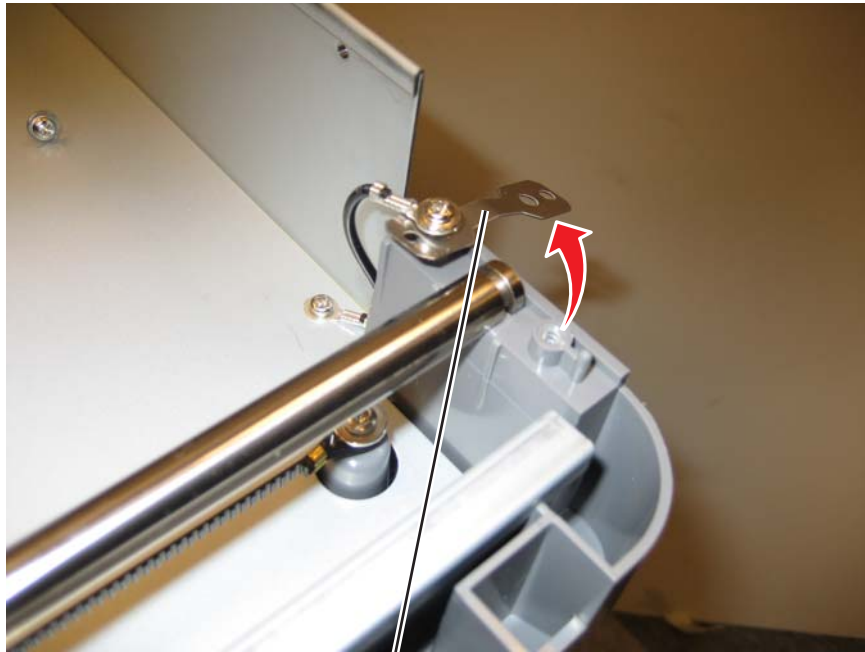

E

6. Lift rod and slide the flatbed CCD carrier module off the rod.



Installation note:

Be sure to route the carriage transport belt correctly.

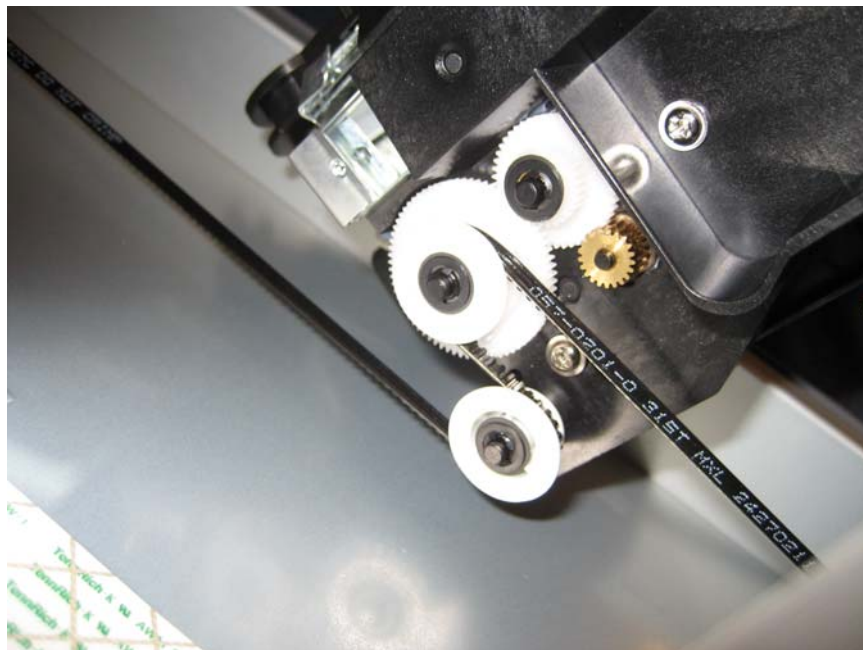

Flatbed cooling fan removal

1. Remove the flatbed with glass cover. See **"Flatbed with glass cover removal"** on page 4-201.
2. Remove the four (A) screws.



3. Remove the fan.

Flatbed scanner removal

1. Remove the ADF. See **“ADF removal (entire)”** on page 4-210.
2. Remove the right cover. See **“Right cover removal”** on page 4-39.
3. Remove the two screws (A) and the smaller screw (B) on the right side.



4. Disconnect the two cables (C) at the connectors on the MDC card (ribbon cable).
Note: Be careful disconnecting and reconnecting the ribbon cables. Ribbon cables can be damaged easily and should be handled carefully.

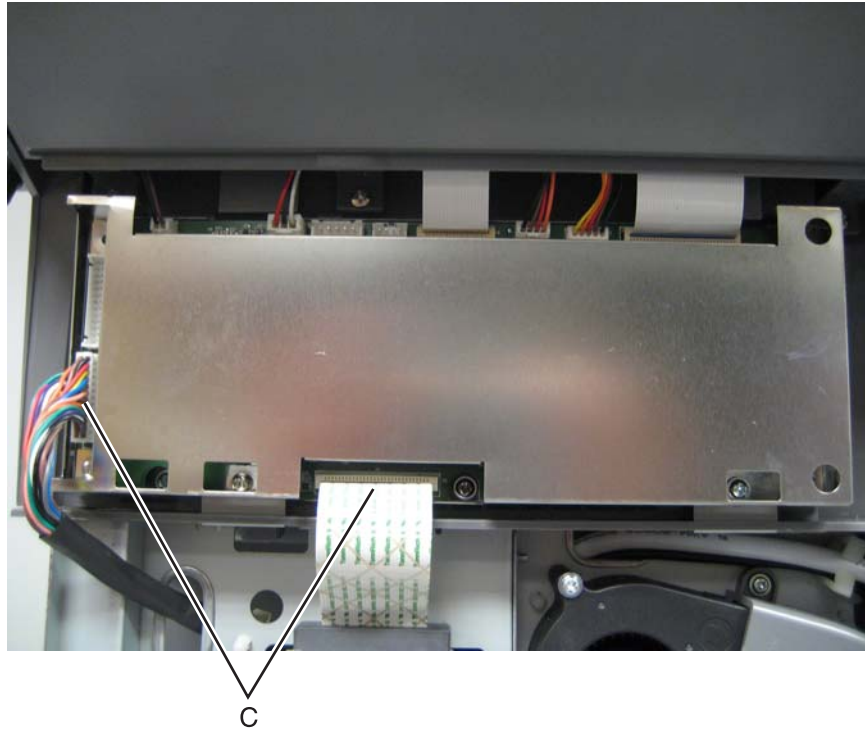

5. Remove the 3 long screws (D) and the two short screws (E)..

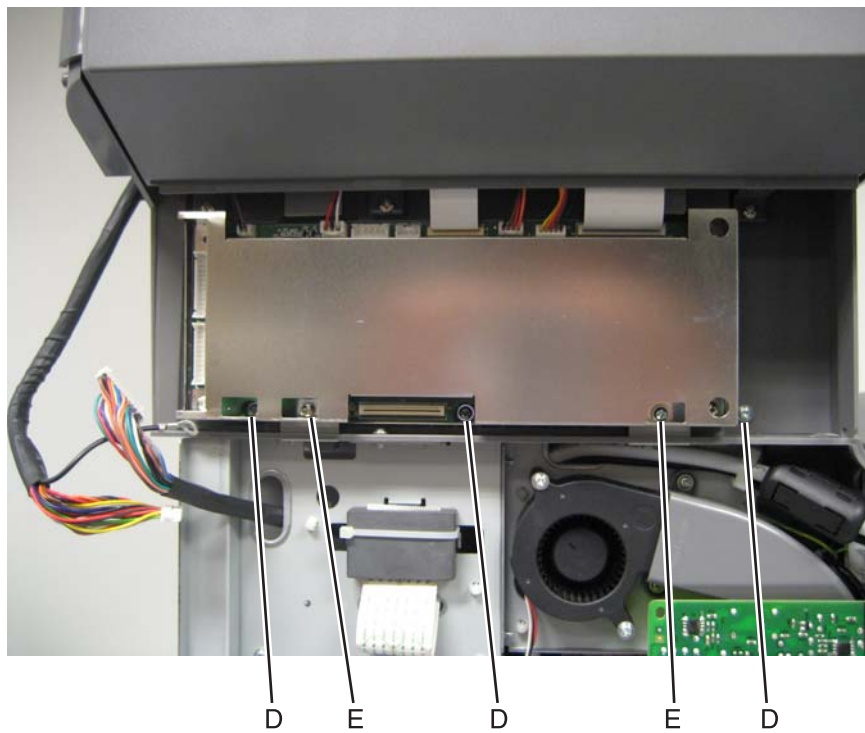

- Slide the flatbed scanner forward, and lift it up to remove it.



Warning: Whenever you replace the ADF (entire), the flatbed scanner, or the MDC card, perform the **“Scanner Manual Registration”** in Configuration menu.

To enter Config Menu:

- Turn off the multifunction printer.
- Press and hold **2** and **6**.



- Turn on the MFP.
- Release the buttons when the progress bar displays.

Paper present LED card removal

1. Remove the input tray. See **“Input tray removal”** on page 4-204.
2. Remove the six screws (A) securing the underside of the input tray.



3. Disconnect the cable at the connector (B).
Note: Observe the routing of the cable for re-installation.
4. Remove the screw (C) securing the LED to the input tray, and removal the paper present LED card.

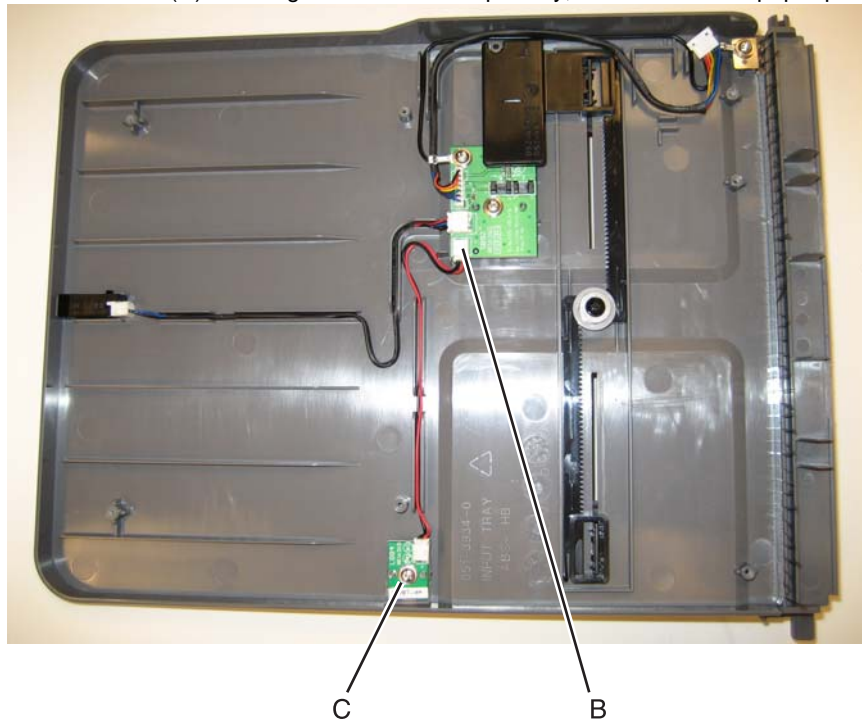

Scanner ICC card removal

1. Remove the ADF. See **“ADF removal (entire)”**
2. Turn the ADF over. Be sure to brace the ADF to prevent damage.
3. Remove the three screws (A) securing the MDC cable cover, and remove the cover.

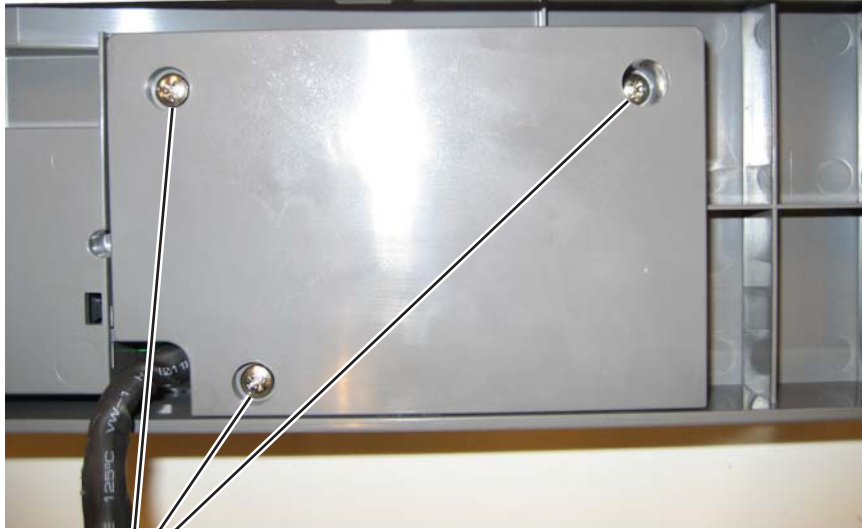

A

4. Disconnect the ICC cable (B) from the scanner ICC card.

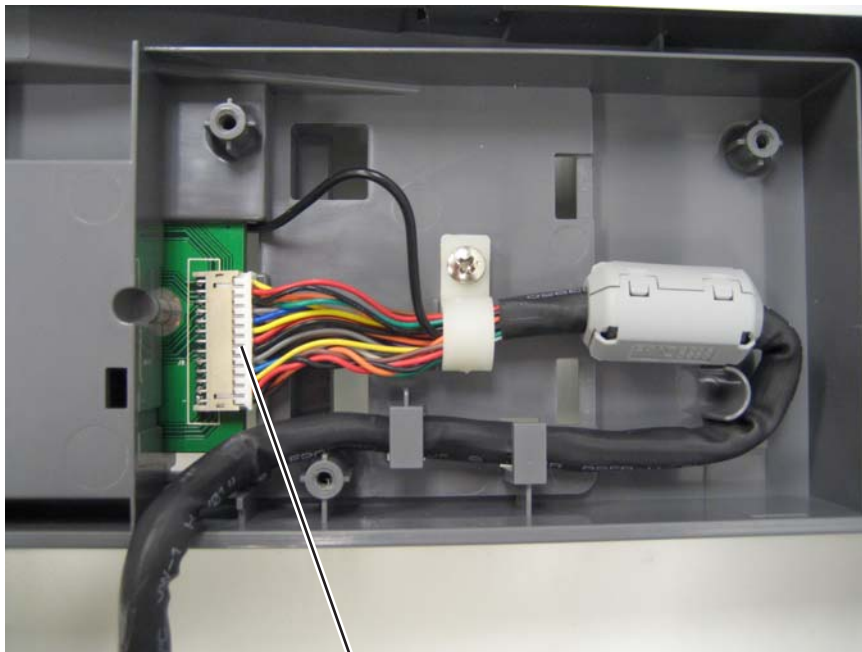

B

5. Turn the ADF over.
6. Remove the ADF motor side cover. See **“ADF motor side cover removal”** on page 4-194.
7. Disconnect all the cables.

8. Remove the two screws (C), and the ground cables from the screws (D).
Note: Be sure to reconnect the ground cables when you reinstall the card.

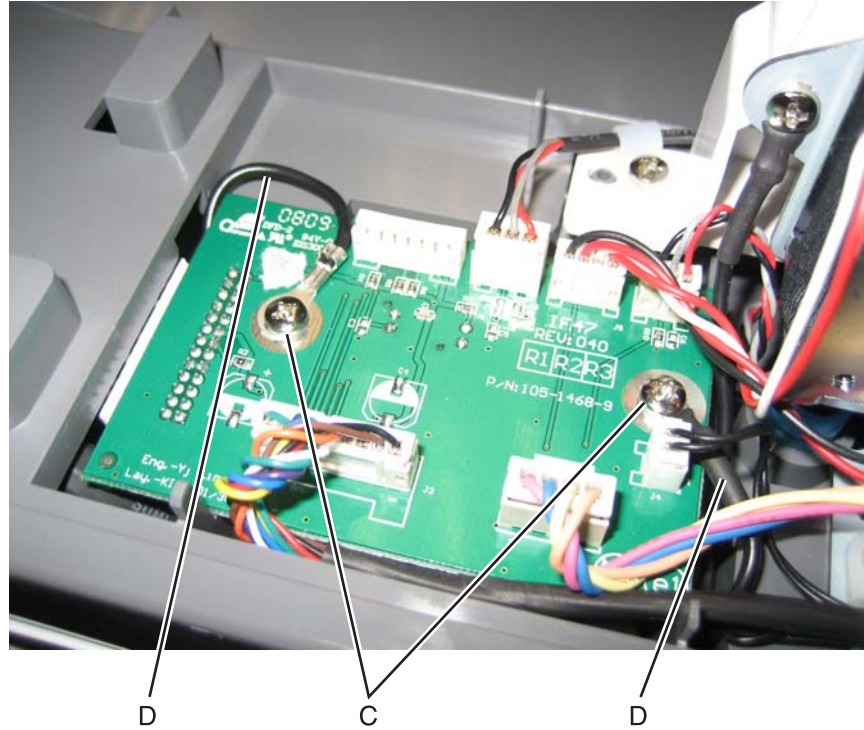

9. Remove the card.

Scanner ICC cable removal

1. Remove the ADF. See **“ADF removal (entire)”**
2. Turn the ADF over. Be sure to brace the ADF to prevent damage.
3. Remove the three screws (A) securing the MDC cable cover, and remove the cover.

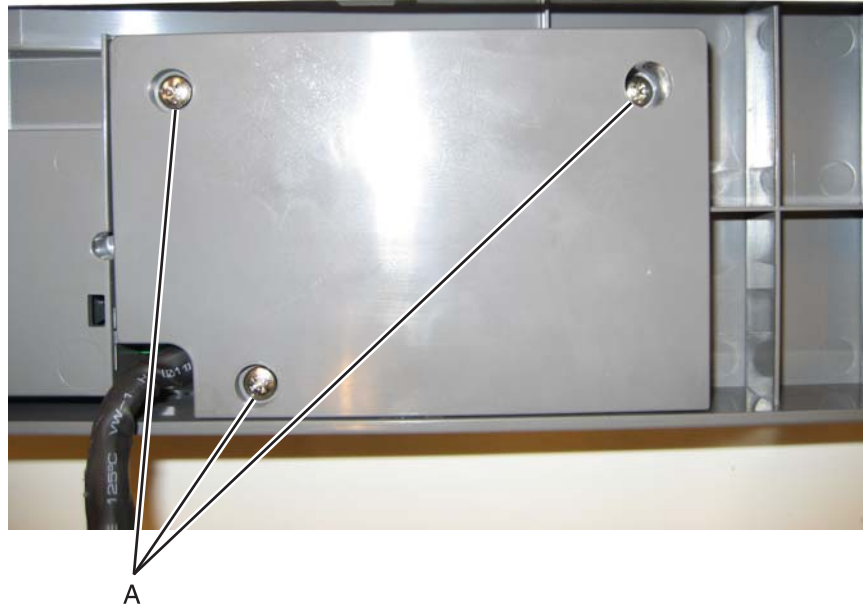

4. Disconnect the ICC cable (B) from the scanner ICC card.

5. Remove the screw (C) securing the cable tie-down, and remove the cable from the tie-down.
6. Remove the cable from the cable restraints (D), and note the routing.
7. Open the clips (E) on the toroid, and set it aside for reinstallation later.

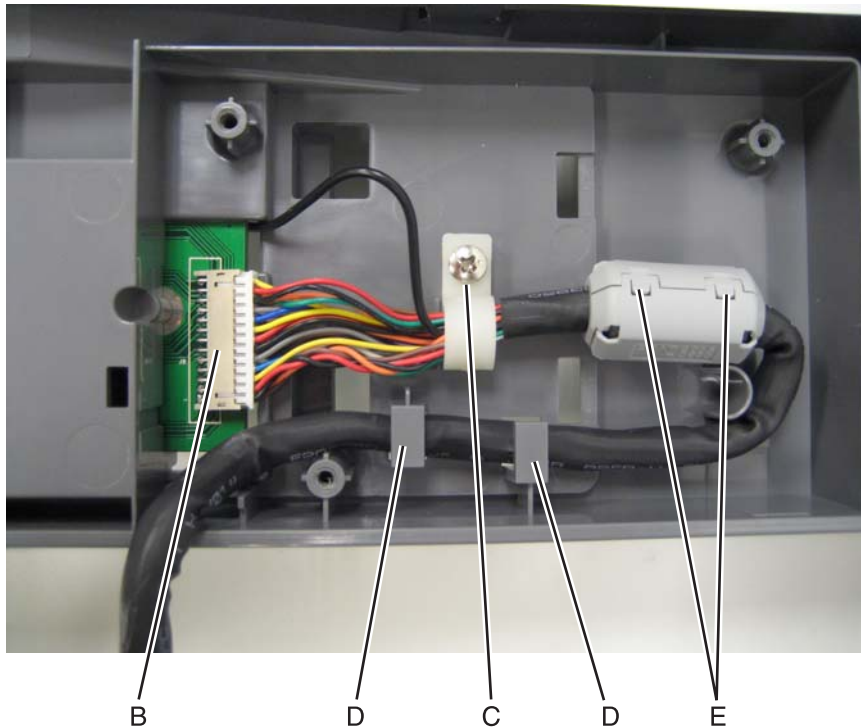

8. Turn the ADF over.
9. Remove the ADF motor side cover. See **“ADF motor side cover removal”** on page 4-194.
10. Remove the screw (F) and disconnect the scanner ICC cable ground cable (G).

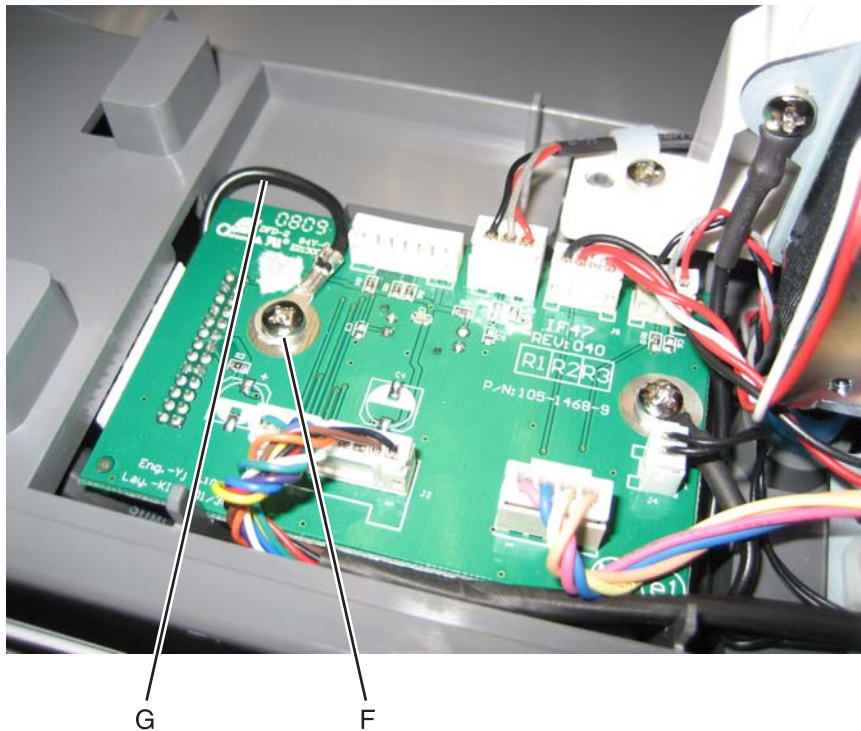

11. Remove the scanner ICC cable.

Scanner MDC card removal

Warning: When replacing any one of the following components:

- Scanner MDC card
- System board

Only replace one component at a time. Replace the required component, and perform a POR before replacing a second component listed above. If this procedure is not followed, the printer will be rendered inoperable.

1. Remove the left cover. See **“Left cover removal”** on page 4-23.
2. Remove the screw (A) that secures the ground cable, and remove the ADF cable (B).

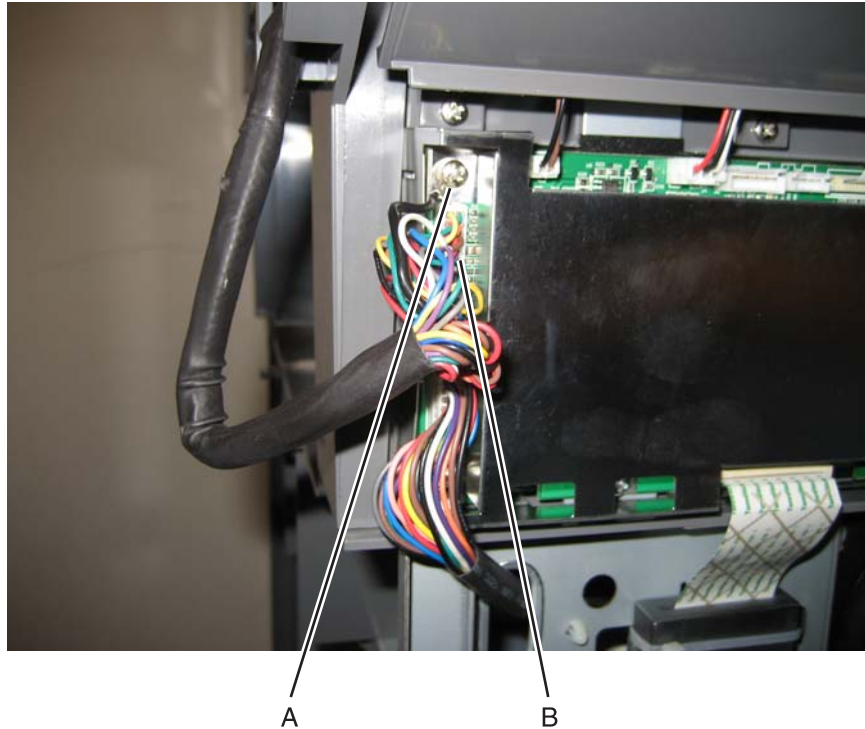

3. Disconnect the eight cables (C) from the MCD card

Warning: Be careful disconnecting and reconnecting the ribbon cables. Ribbon cables can be damaged easily and should be handled carefully.

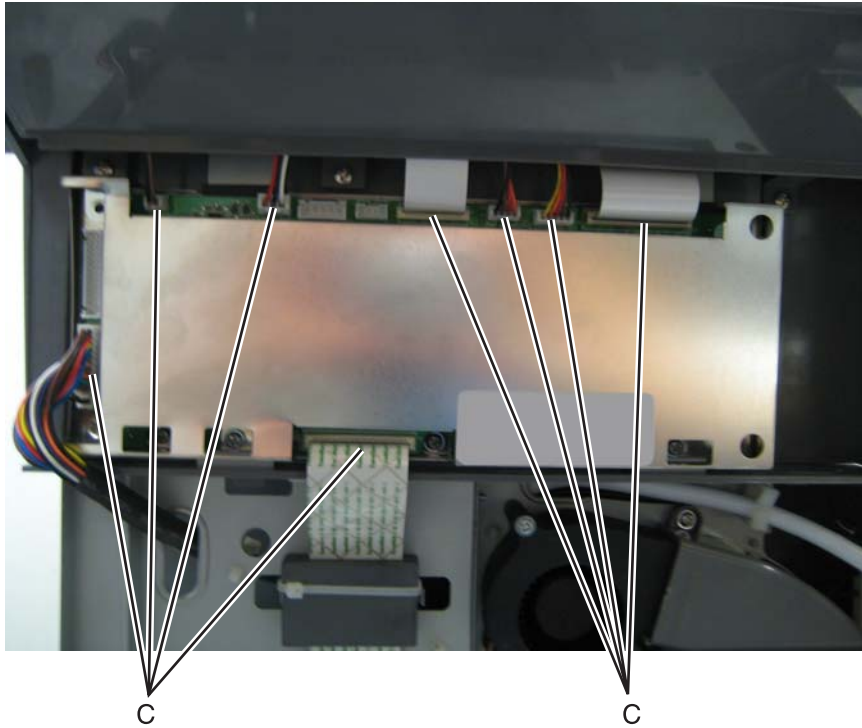

4. Remove the three screws (D) from the MDC card cage.

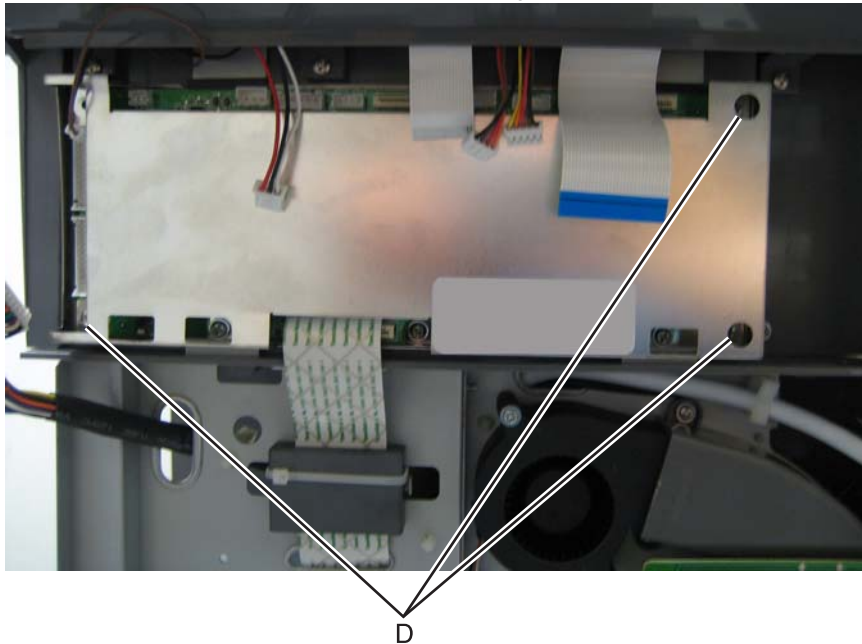

5. Remove the MDC card cage.

6. Remove the three screws (E) securing the MDC card, and remove the MDC card.

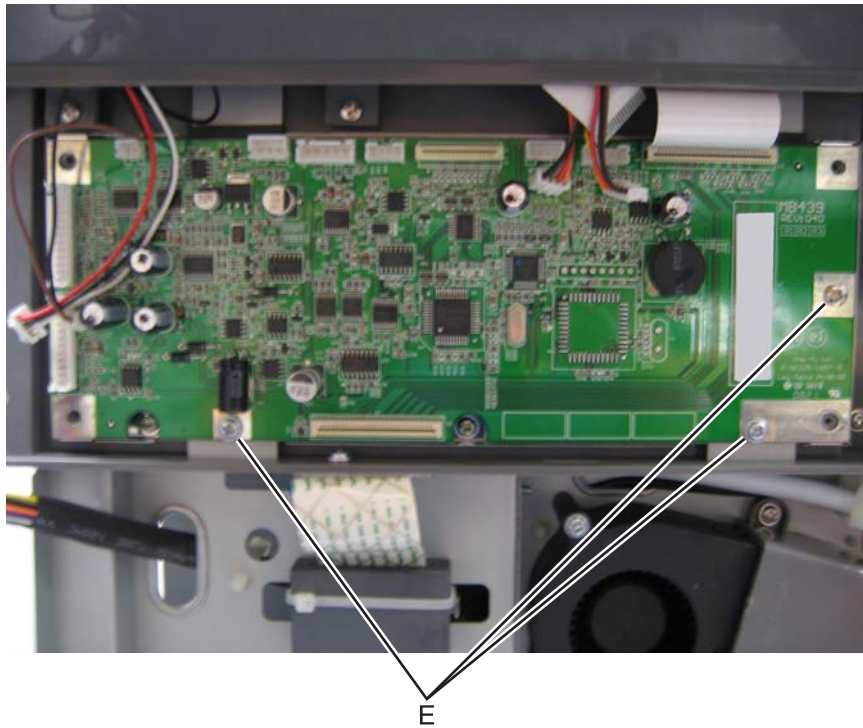

Warning: Whenever you replace the ADF (entire), the flatbed (entire), or the MDC card, perform the **“Scanner Manual Registration”** in Configuration menu.

To enter Config Menu:

1. Turn off the multifunction printer.
2. Press and hold **2** and **6**.



3. Turn on the MFP.
4. Release the buttons when the progress bar displays.

High-capacity input tray (HCIT) option removals

HCIT media tray assembly removal

Note: When removing the high-capacity input tray (HCIT) media tray assembly, it is not necessary to remove it from the base machine and the caster base.

1. Open the HCIT media tray assembly (A) until it reaches a stop.
2. Press the latches (B) on the left and right side of the HCIT tray slides.



3. Slide the HCIT media tray assembly out of the drawer.

HCIT front tray cover removal

Note: When removing the high-capacity input tray (HCIT) front tray cover, it is not necessary to remove the HCIT media tray assembly from the base machine and the caster base.

1. Remove the HCIT media tray assembly. See **“HCIT media tray assembly removal” on page 4-250.**
2. Remove the six screws (A) securing the HCIT front tray cover to the media tray assembly.
3. Remove the HCIT front tray cover.

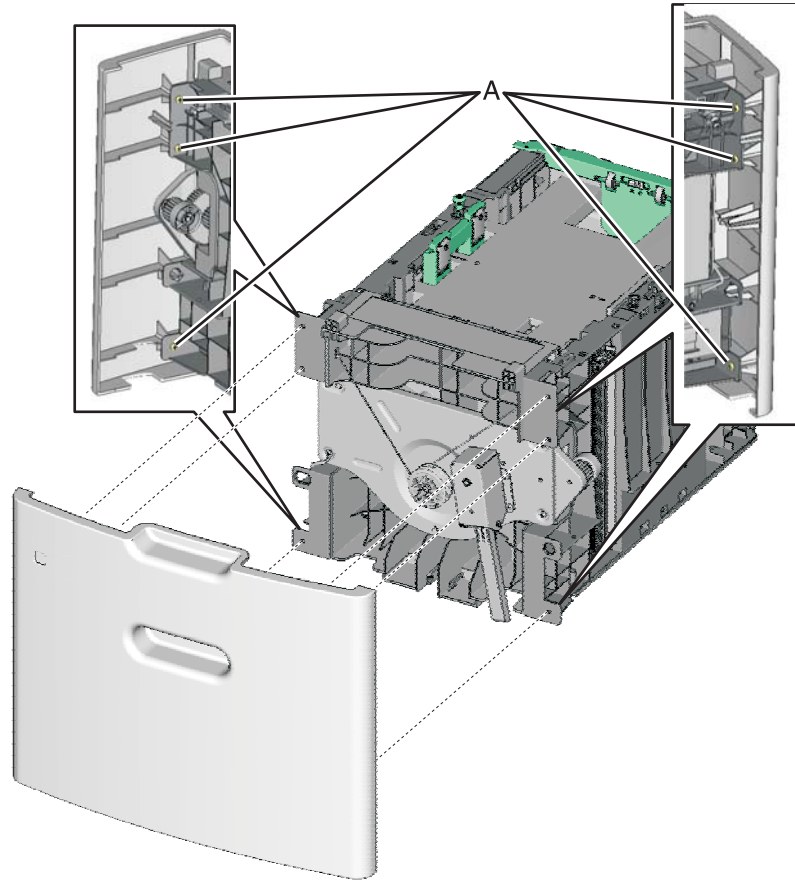

HCIT rear cover removal

1. Remove the four screws (A) securing the HCIT rear cover to the drawer.
2. Remove the HCIT rear cover.

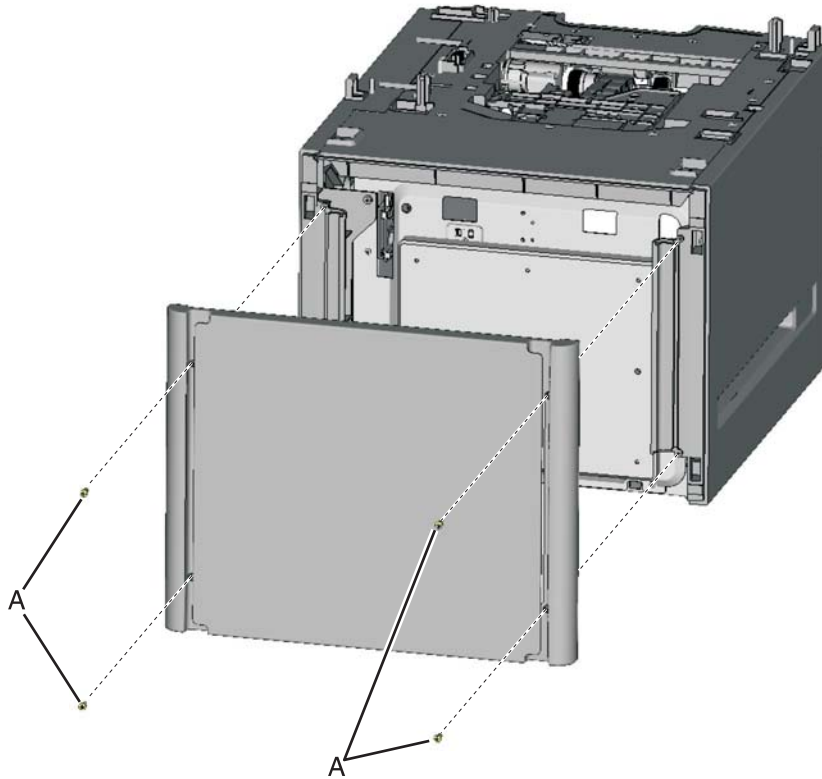

HCIT right cover removal

1. Carefully remove the printer or multifunction printer from the high-capacity input tray (HCIT) and remove the HCIT from the caster base.
2. Remove the HCIT media tray assembly. See **"HCIT media tray assembly removal"** on page 4-250.
3. Remove the HCIT rear cover. See **"HCIT rear cover removal"** on page 4-252.
4. Remove the six screws (A) securing the HCIT right cover to the drawer.

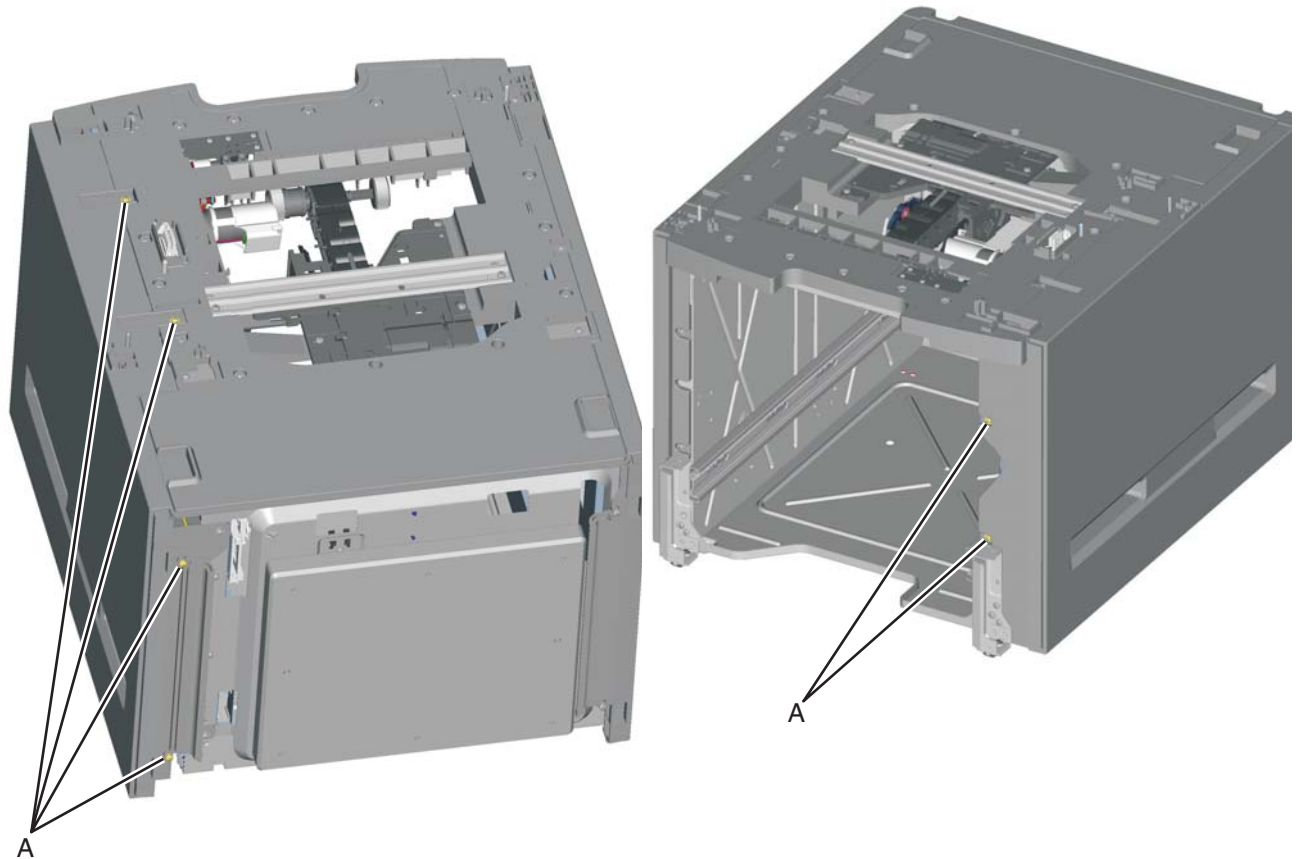

5. Remove the HCIT right cover.

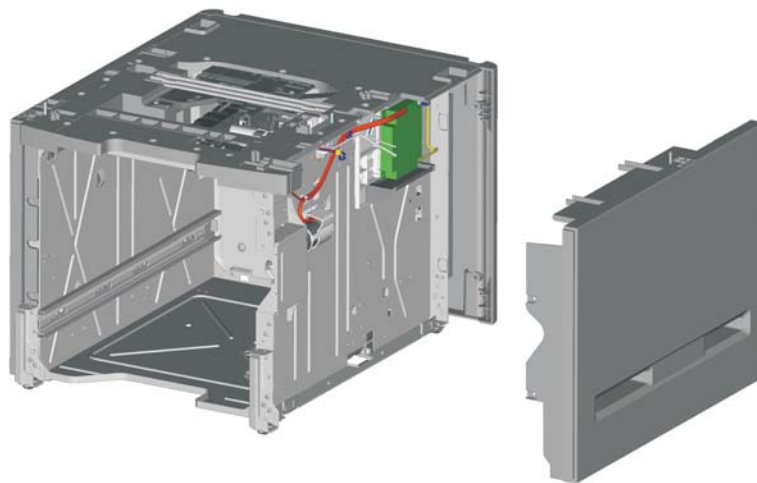

HCIT left cover removal

1. Carefully remove the printer or multifunction printer from the high-capacity input tray (HCIT) and remove the HCIT from the caster base.
2. Remove the HCIT media tray assembly. See **“HCIT media tray assembly removal”** on page 4-250.
3. Remove the HCIT rear cover. See **“HCIT rear cover removal”** on page 4-252.
4. Remove the six screws (A) securing the HCIT left cover to the drawer.

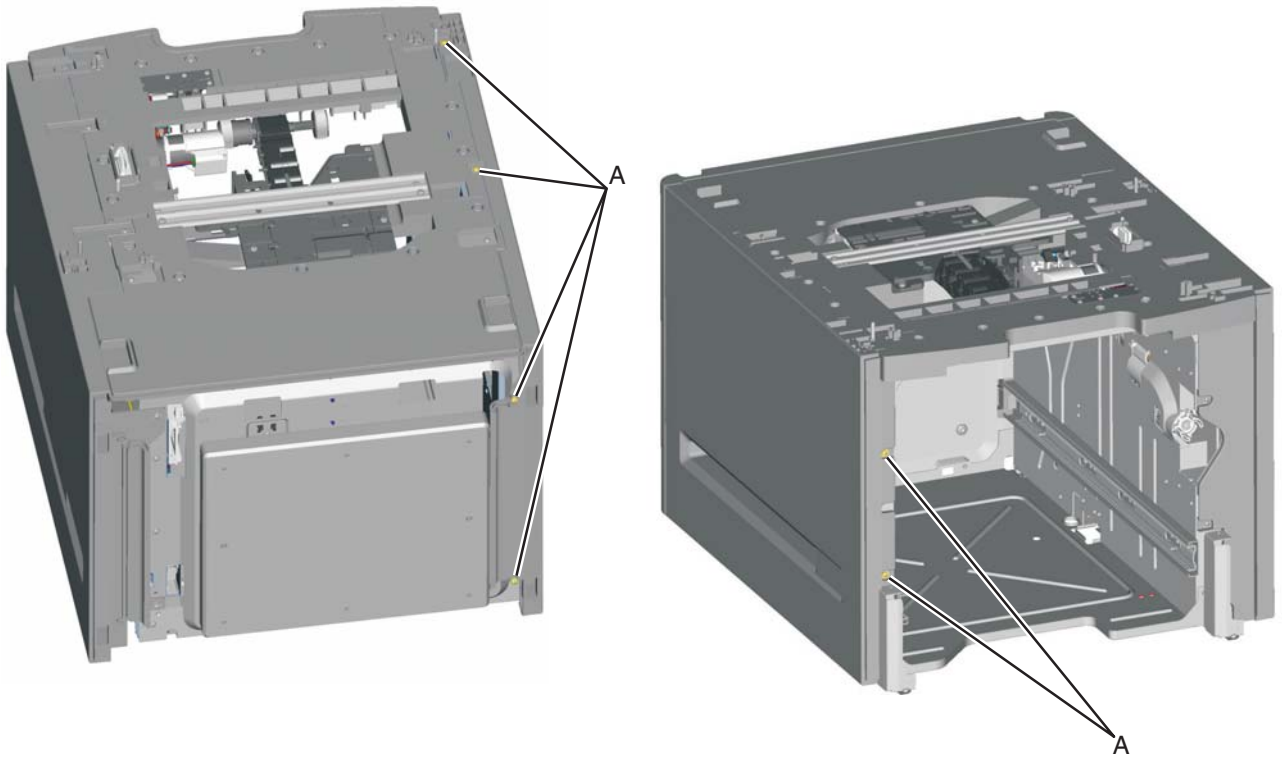

5. Remove the HCIT left cover.

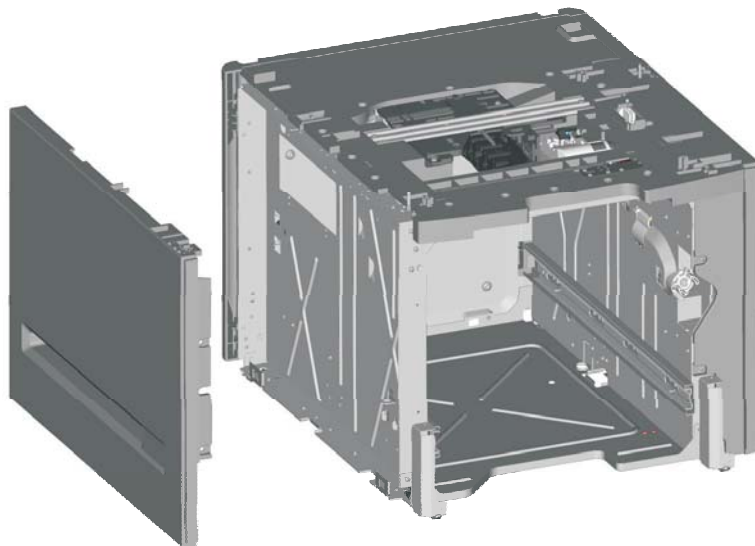

Feed with bushing roller removal

1. Remove the high-capacity input tray (HCIT) top plate assembly. See **“Top plate assembly removal”** on **page 4-264**.
2. Remove the four screws (A) securing the pass thru sensor bracket to the top plate assembly.
Note: The bushing may come off when removing the pass thru sensor bracket.

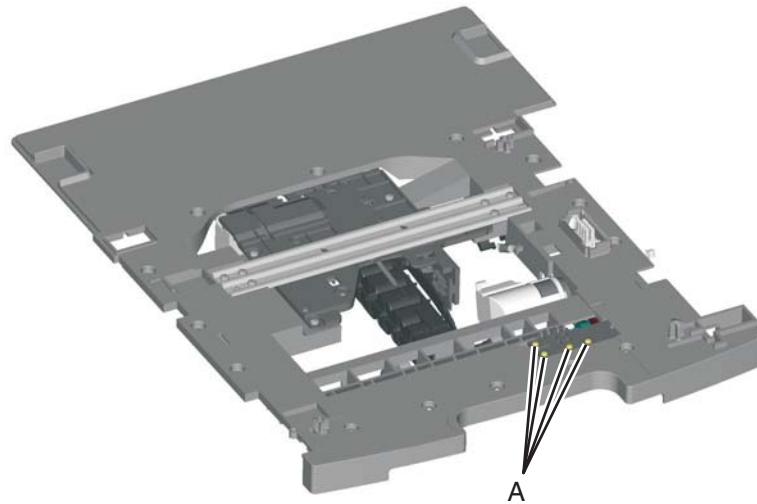

3. Remove the screw (B) securing the 46T gear (C) to the top plate assembly.
4. Remove the 46T gear.
5. *Snap* loose the feed roller (D), and remove.

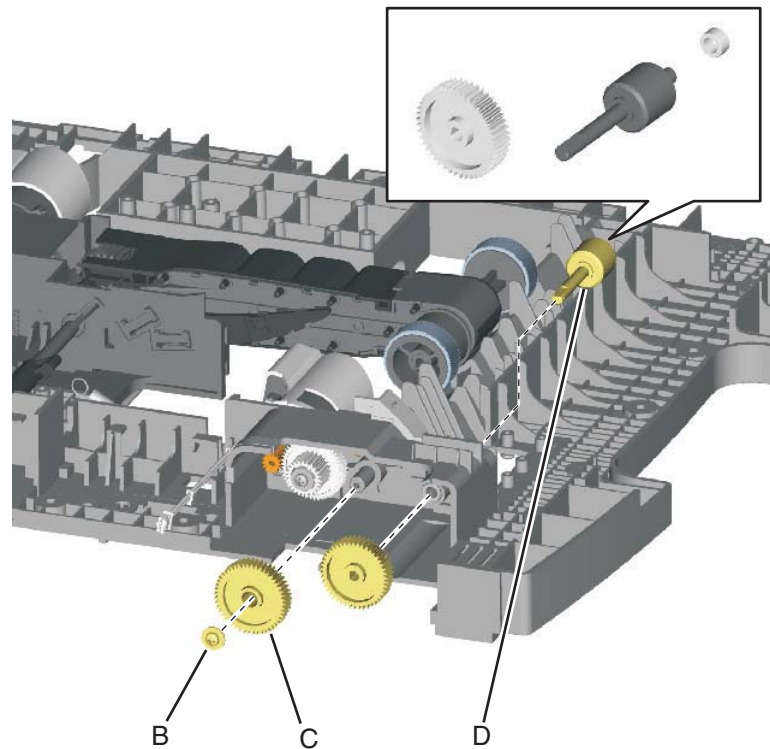

HCIT controller board assembly removal

1. Remove the HCIT right cover. See **“HCIT right cover removal”** on page 4-253.
2. Disconnect the seven connectors (A) from the HCIT controller board.

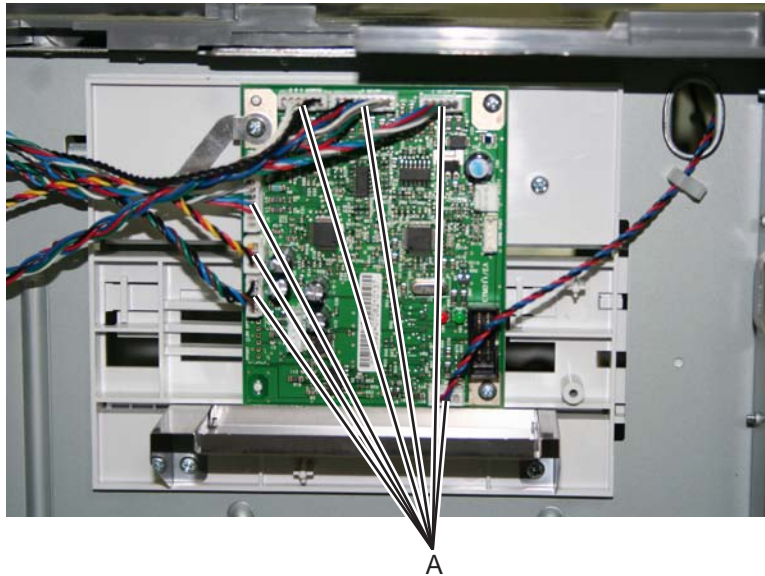

3. Remove the ground screw (B) from the HCIT controller board.
4. Remove the two screws (C) securing the HCIT controller board to the card mount option.

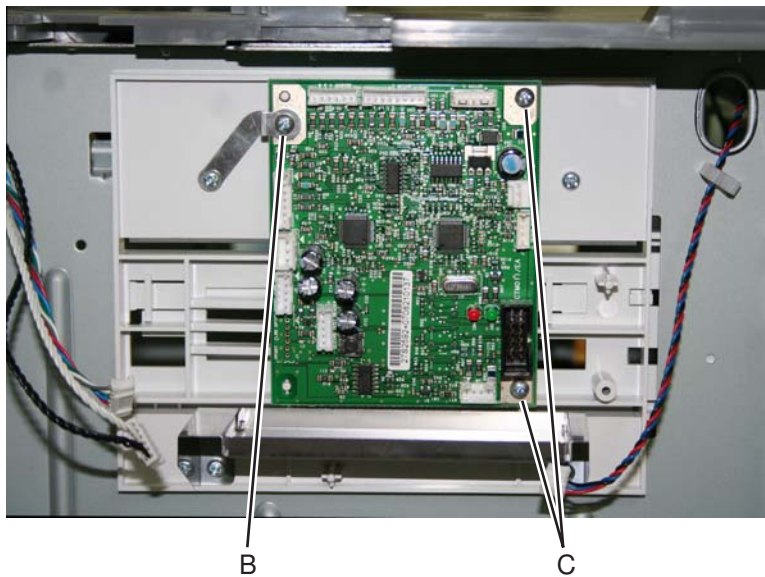

5. Remove the HCIT controller board.

HCIT drawer slide assembly removal

The left and right drawer slide assemblies are the same, and only one is in a package. The instructions below are for removing the left slide, but removing the right slide is similar.

1. Remove the HCIT media tray assembly. See **“HCIT media tray assembly removal” on page 4-250.**
2. Remove the three screws (A) securing the HCIT drawer slide to the side frame.

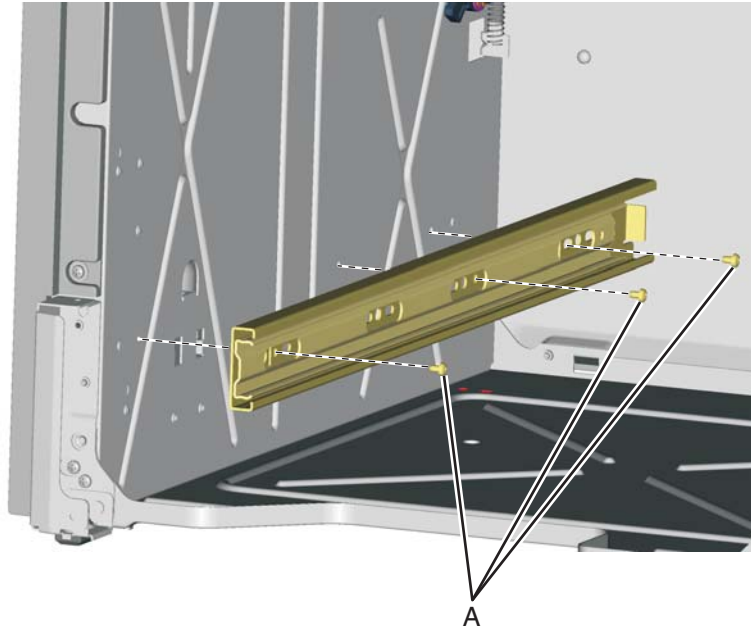

3. Remove the HCIT drawer slide.

HCIT elevator motor with sensor removal

1. Remove the HCIT right cover. See **“HCIT right cover removal” on page 4-253.**
2. Disconnect the connector (A) from the HCIT controller board.

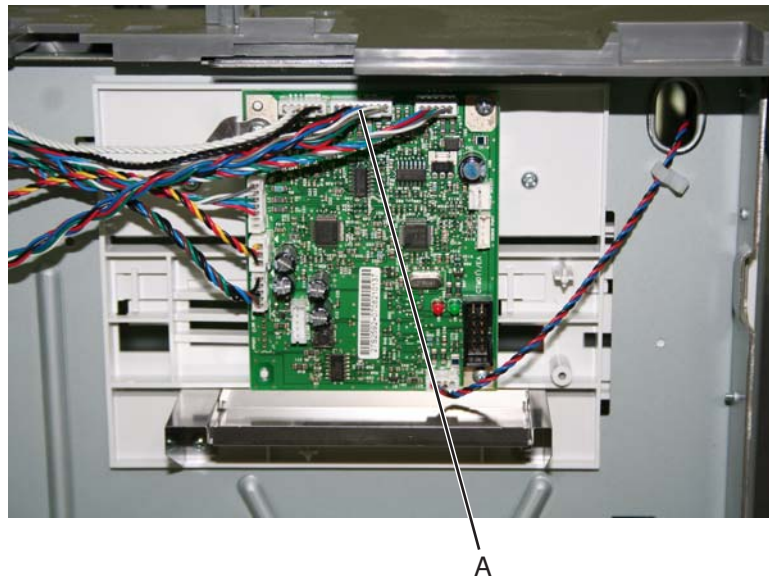

3. Release the hooks (B) securing the pass thru sensor to the top plate assembly.
4. Remove the pass thru sensor from the top plate assembly.
5. Release the harness from the clamps (C).
6. Remove the eight screws (D) securing the elevator motor with sensor to the side frame.

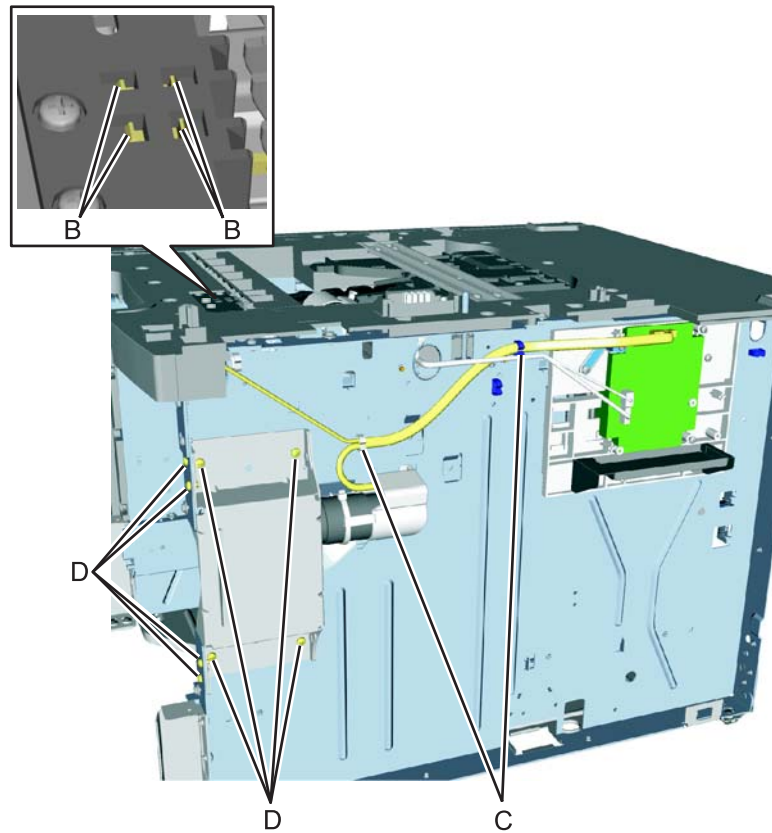

7. Remove the elevator motor with sensor.

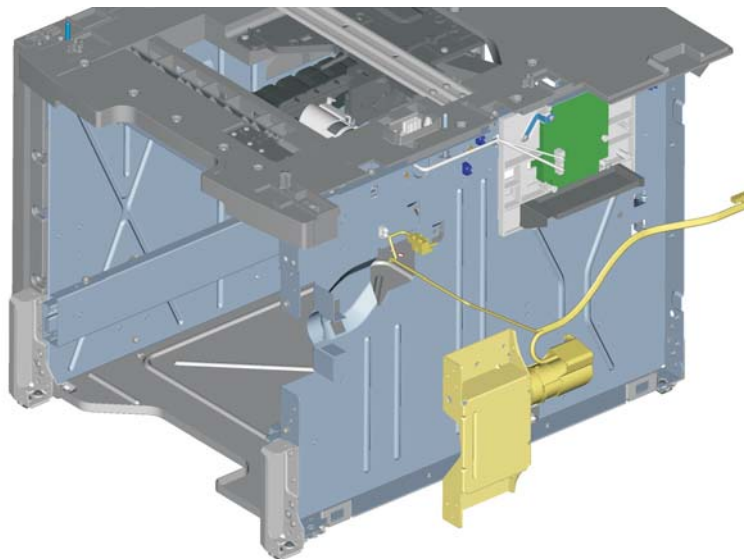

HCIT pick tires removal

1. Remove the high-capacity input tray (HCIT) media tray assembly. See **“HCIT media tray assembly removal”** on page 4-250.
2. Pull the autocompensator pick arm (A) down.

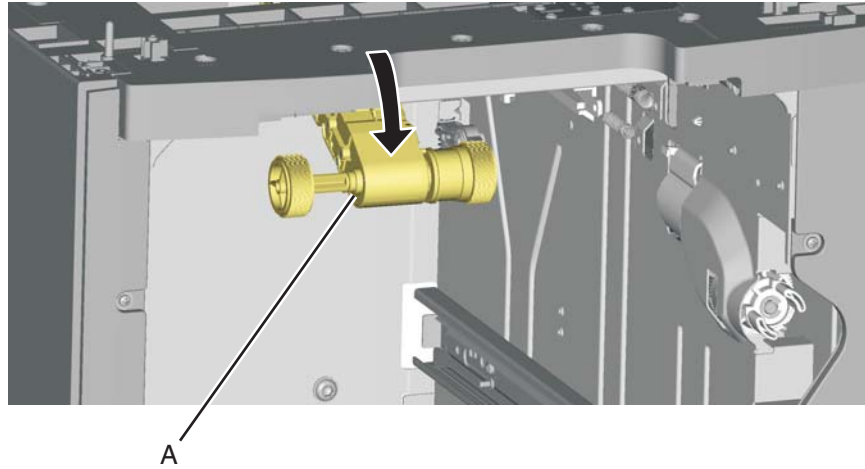

3. Remove the pick tire (B) from the pick roll assembly (C).
 4. Repeat for the other pick tire (D).
- Note:** Always replace the pick tires as pairs.

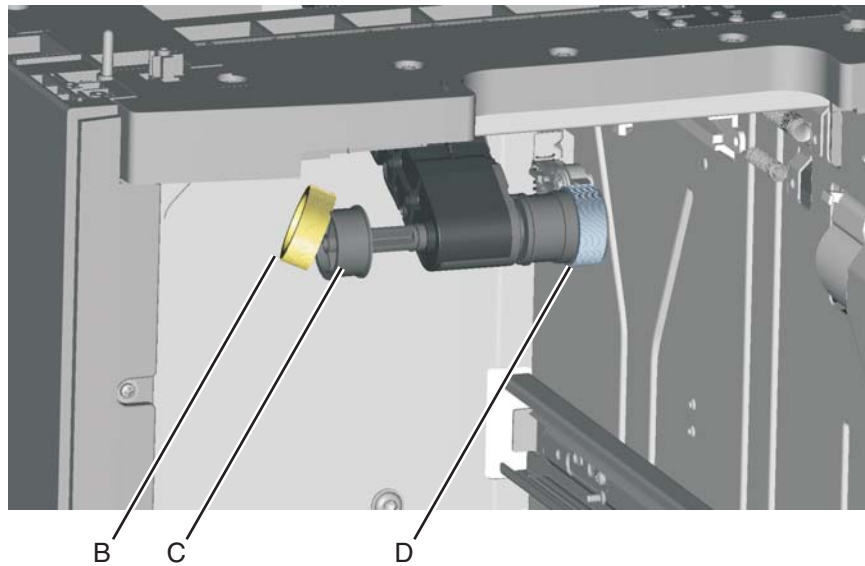

HCIT slide assembly with spring removal

1. Remove the HCIT controller board assembly. See **“HCIT controller board assembly removal”** on **page 4-256**.
2. Disconnect the two springs (A) from the frame.
Note: Leave the springs attached to the cam size sensing plate (B) and the actuator switch.
3. Slide the cam size sensing plate (B) through the access hole in the rear side frame.

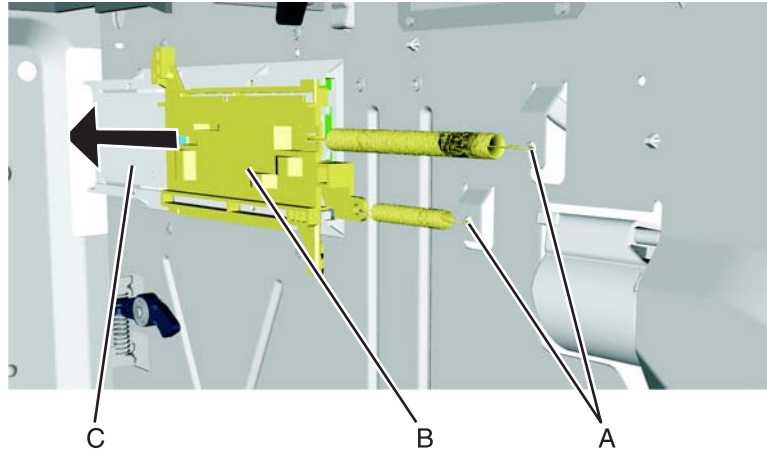

4. Remove the media size actuator from the card mount option (C).
5. *Snap* loose the actuator switch (D), and remove.

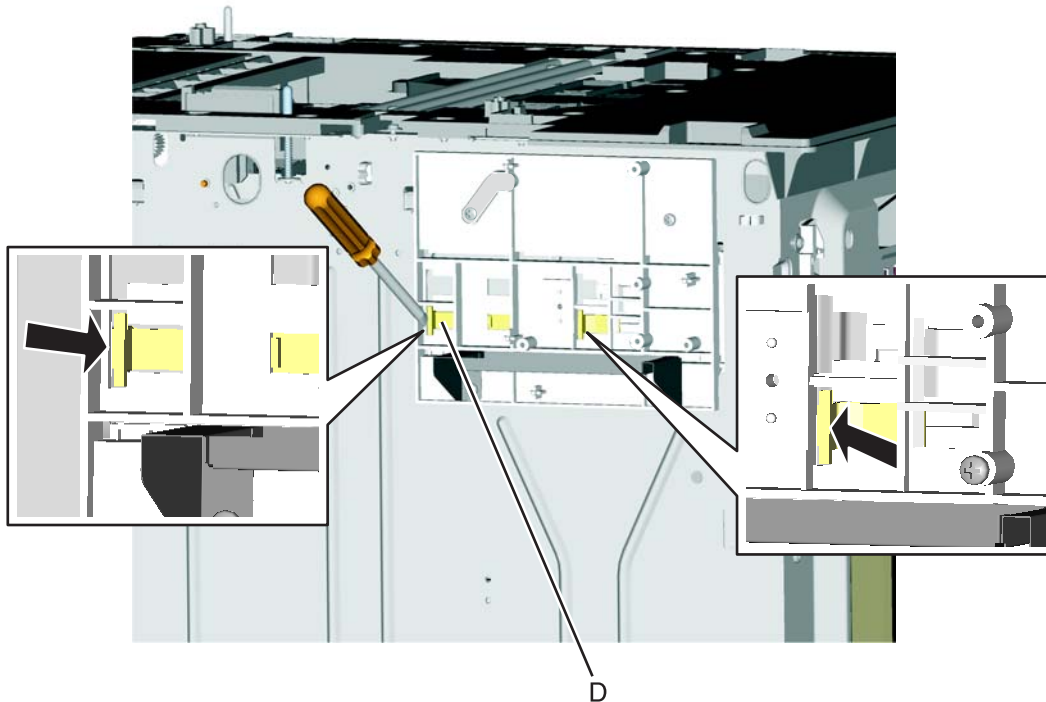

6. Remove the four screws (E) securing the card mount option to the frame.

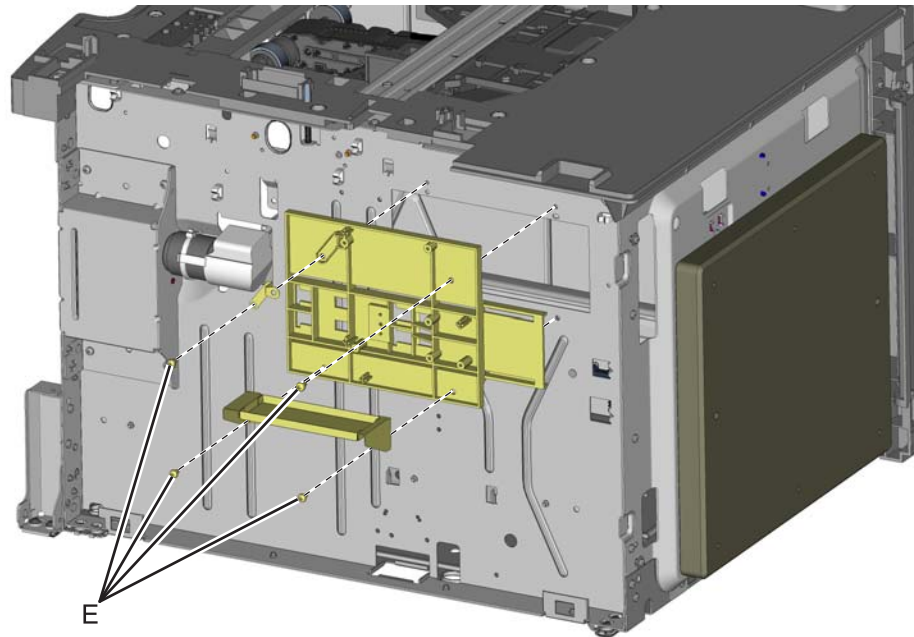

7. Remove the card mount option.

Installation note:

1. Place the card mount option into position, and secure it with the four screws.
2. Reinstall the media size actuator to the card mount option.
3. Reinstall the actuator switch with spring through the inside of the drawer.
4. Reinstall the cam size sensing plate with spring through the access hole in the rear side.
5. Reattach the two springs to the frame.

Photointerrupter sensor with cable assembly removal



1. Remove the high-capacity input tray (HCIT) right cover. See **“HCIT right cover removal”** on page 4-253.
2. Disconnect the photointerrupter sensor cable connector (A) from the HCIT controller board.



A

3. Turn the drawer rear side down, and use 4.0 mm wrench to remove the four allen screws (B) securing the counterweight to the rear frame.

Warning: Do *not* remove the screws without turning the drawer rear side down first. The counterweight is very heavy; it might fall and cause damage.

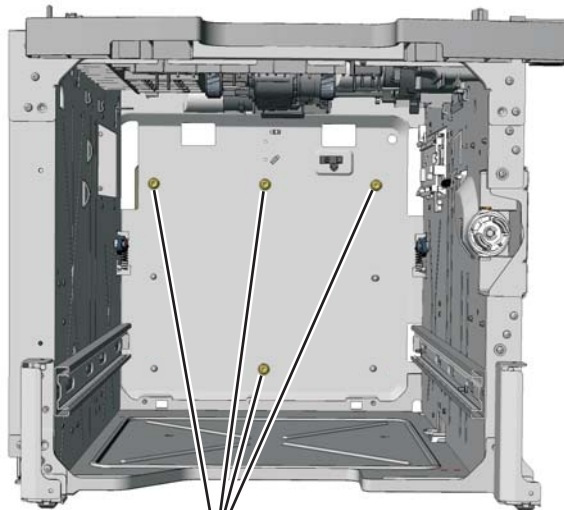

B

4. Remove the screw (C) securing the sensor to the rear frame, and then release the hooks (D).
Note: Remove the cable from the restraint, and observe the routing for reinstallation.

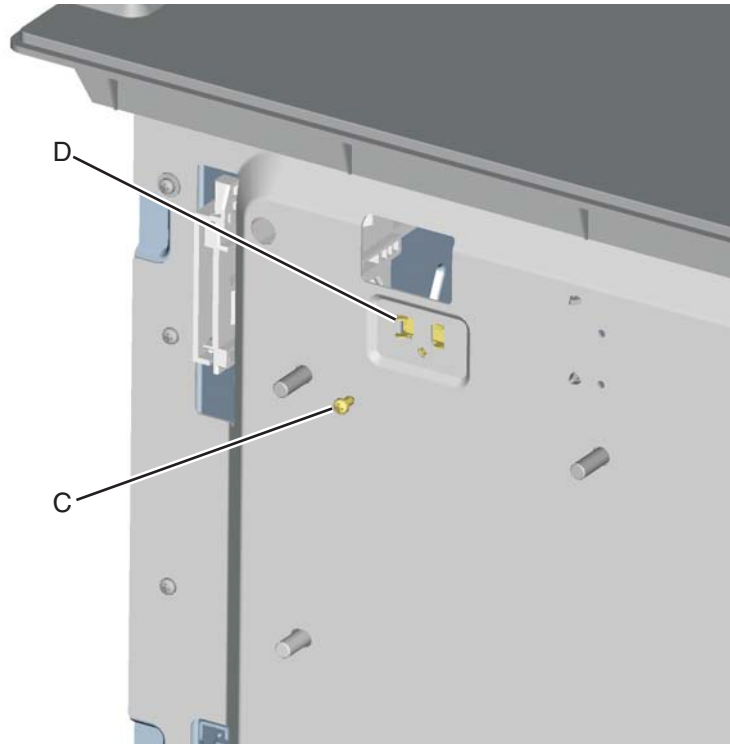

5. Remove the photointerrupter sensor with cable assembly.

Top plate assembly removal

1. Remove the high-capacity input tray (HCIT) right cover. See **“HCIT right cover removal” on page 4-253.**
2. Disconnect the five connectors (A) from the HCIT controller board.

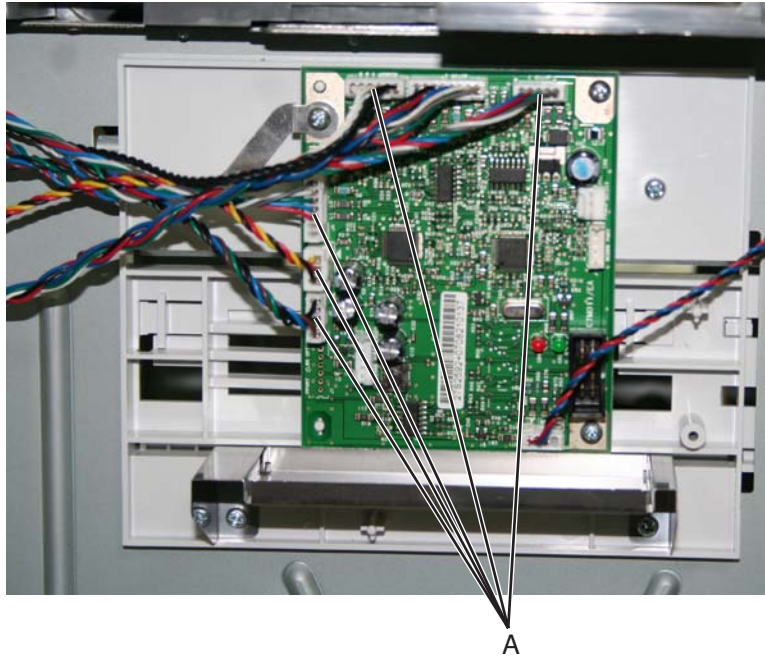

3. Release the hooks (B) securing the pass thru sensor from the top plate assembly.
4. Remove the fourteen screws (C) securing the top plate assembly to the frame.

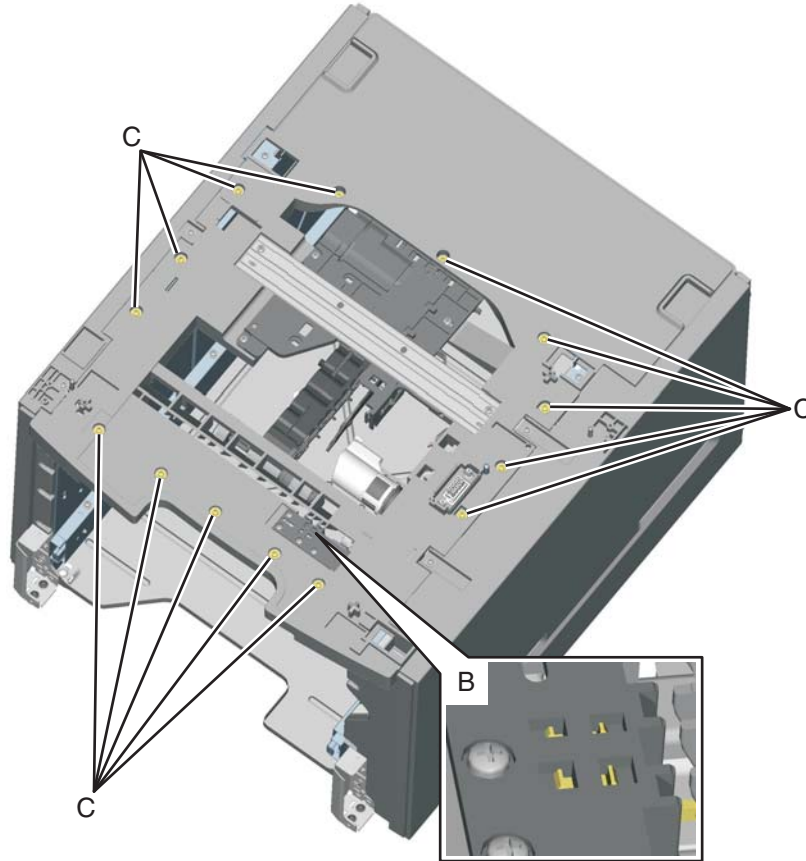

5. Remove the top plate assembly.

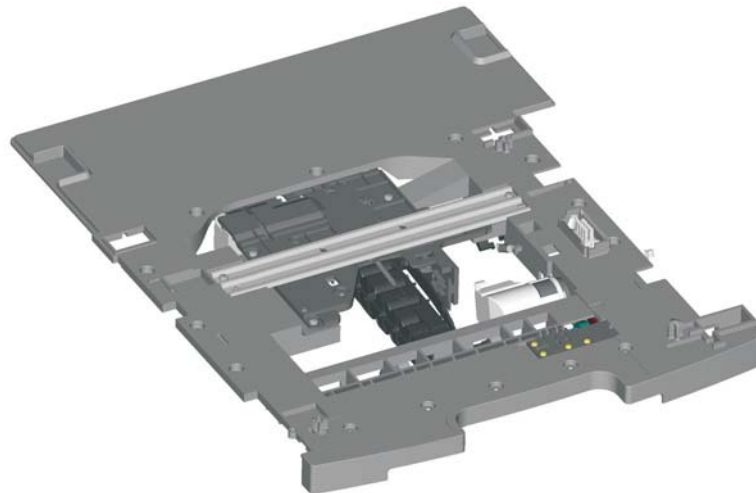

5. Connector locations

Locations—printer base

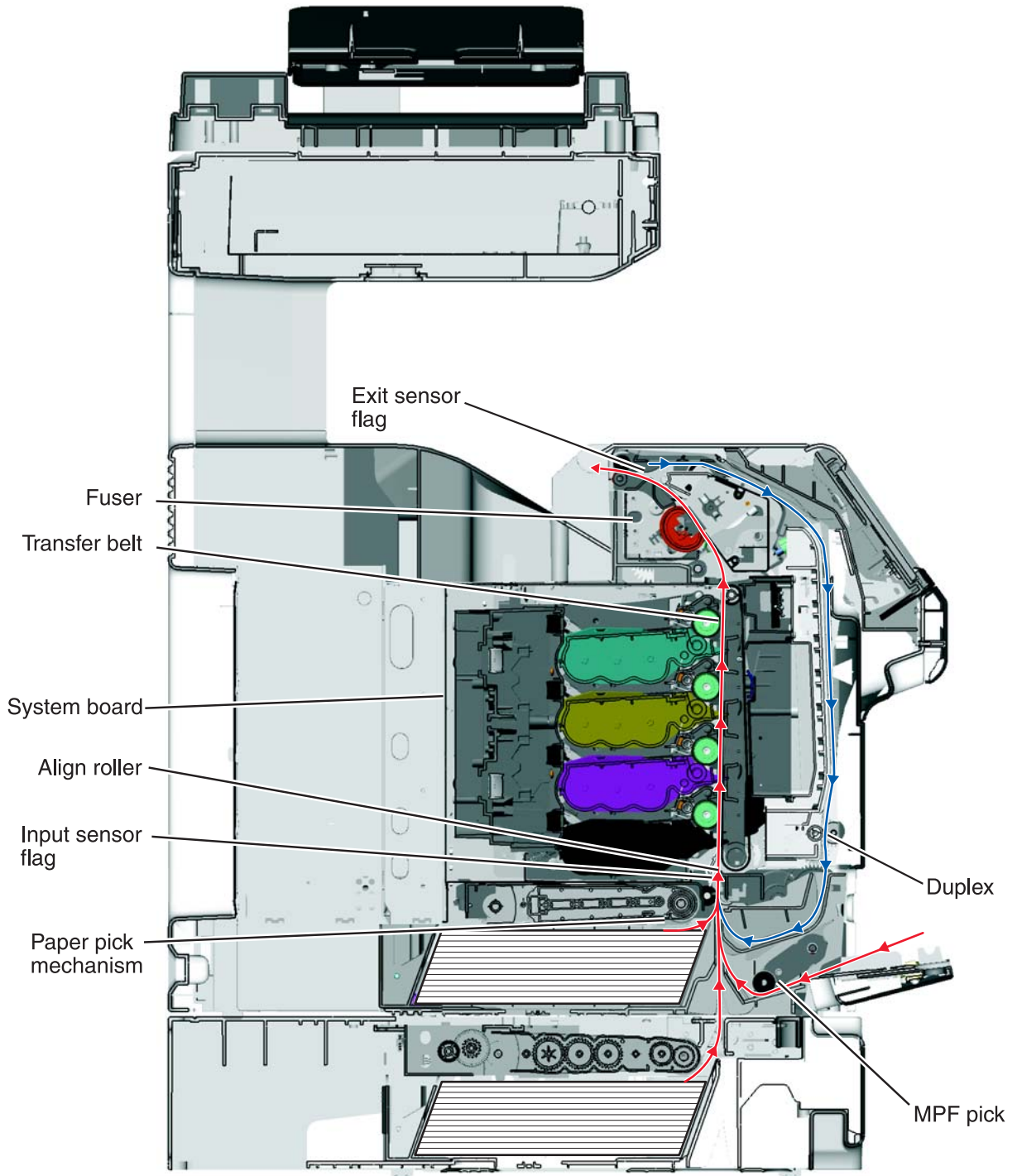

System board listing

See "System board" on page 5-2.

Connector	Pin #	Signal	Pin #	Signal
J1 AIO motor driver control (MDC)	1	Ground	2	FBR_LVDS_MCLK+
	3	FBR_LVDS_MCLK-	4	Ground
	5	FBR_LVDS_RXCLK-	6	FBR_LVDS_RXCLK+
	7	Ground	8	FBR_LVDS_RXIN2+
	9	FBR_LVDS_RXIN2-	10	Ground
	11	FBR_LVDS_RSIN1+	12	FBR_LVDS_RXIN1-
	13	Ground	14	FBR_LVDS_RXIN0-
	15	FBR_LVDS_RXIN0+	16	Ground
	17	FBR_AFE_NRST_R	18	Ground
	19	FBR_AFE_SDIO-R	20	FBR_AFE_SCK_R
	21	FBR_AFE_SEN_	22	FBR_AFE_SH_R
	23	FB_PWRSVR_R	24	+5V_F_AIO
	25	+5V_F_Aio	26	Ground
	27	24V_FB_CDU	28	24V_FB_CDU
	29	FB_LAMP_ON_R	30	Ground
J2 UART MDC control	1	Ground	2	24V_MDC
	3	24V_MDC	4	24V_MDC
	5	Ground	6	TOP_FB_CN
	7	BOOT_SEL_DN	8	+5V_F_AIO
	9	+5V_F_AIO	10	Ground
	11	MDC_RXD_CN	12	MDC_TXD_CN
	13	Ground	14	ADF_PAPER_PRES_R
	15	FB_COV_CLOSED_R	16	Ground
	17	MDC_RES1_CN	18	MDC_RES2_CN
	19	Ground	20	MDC_RST_NR
	21	3.3v_MDC	22	Ground
	23	I2C_CLK_MDC_R	24	I2C_DATA_MDC_R
J3 Ethernet port	1	UI_RESET_NR	2	Ground
	3	Y1M_LVDS	4	Y1P_LVDS
	5	Y2M_LVDS	6	Y2P_LVDS
	7	CLK_TX-	8	CLK_TX+
	9	Ground	10	5V_UI
	11	RXD232_N	12	TXD232_N
	13	Y0M_LVDS	14	Y0P_LVDS
	15	Ground	16	5V_UI
	17	5V_UI	18	5V_UI

System board listing (continued)See **“System board”** on page 5-2.

Connector	Pin #	Signal	Pin #	Signal
J5 Internal Service Port (ISP)	1	Ground		
	2	USBOUT+		
	3	USBOUT-		
	4	Ground		
	5	USBIN+		
	6	USBIN-		
	7	Ground		
	8	A0		
	9	RESET		
	10	+5 V dc		
	11	I2C_DAT		
	12	+5 V dc		
	13	I2C_CLK		
	14	+5 V dc		
J6 Feedback Vortex UART MDC	1	Ground		
	2	MDC_RXD		
	3	MDC_TXD		
J7 AIO Flatbed CCD interface	1	CS_CUHD_R		
	2	Ground		
	3	SDI_CUHD_R		
	4	Ground		
	5	SDO_CUHD_R		
	6	Ground		
	7	CLK_CUHD_R		
	8	Ground		
	9	DSPIRQ		
	10	+5V_AIO		
	11	POR_CUHD_R-		
	12	+3.3 V dc		
	13	+3.3 V dc		
	14	NC		
J9 AIO UICC serial port	1	Ground		
	2	UI_RXD		
	3	UI_TXD		
	4	+5 V dc		

System board listing (continued)

See “System board” on page 5-2.

Connector	Pin #	Signal	Pin #	Signal
J10 Network	1	D_PHY_TX+		
	2	D_PHY_TX-		
	3	D_PHY_RD+		
	4	V_ANA2.5		
	5	V_ANA2.5		
	6	D_PHY_RD		
	7	NC		
	8	V_BOBSMITH		
	9	+2.5V_PHY_I		
	10	PHYLED0		
	11	+2.5V_PHY_I		
	12	PHYLED1		
	10A	PHYLED0		
	11A	+2.5V_PHY_I		
	12A	PHYLED1		
	9A	+2.5V_PHY_I		
J49 Fan	1	+5 V dc		
	2	+5 V dc or Ground		
	3	FANSENSE		
JBIN1 Output bin sensor	1	VS12_BF		
	2	S_BIN_FB		
	3	Ground		
JBLW1 Cartridge blower	1	S_BLOW_FG		
	2	V18_BLOW_RTN		
	3	BLT_BLOW_FB		
JBOOT1 0	1	+3.3 V dc		
	2	+3.3 V dc or Ground		
JBOR1 COD BCD motor	1	V24_BOR-		
	2	V24_BOR+		
JBUSB1 Rear USB host port	1	V_USB		
	2	USB_DM2		
	3	USB_DP2		
	4	Ground		
	G1	Ground		
	G2	Ground		

System board listing (continued)

See "System board" on page 5-2.

Connector	Pin #	Signal	Pin #	Signal
JCARTP1 Cartridge 1/fuser motors	1	V48_CART1_WIND_W		
	2	V48_CART1_WIND_V		
	3	V48_CART1_WIND_U		
	4	V24_FUSER2_W		
	5	V24_FUSER2_V		
	6	V24_FUSER2_U		
JCARTP2 Cartridge 2/cartridge 3 motors	1	V48_CART3_WIND_W		
	2	V48_CART3_WIND_V		
	3	V48_CART3_WIND_U		
	4	V48_CART2_WIND_W		
	5	V48_CART2_WIND_V		
	6	V48_CART2_WIND_U		
JCARTS1 Cartridge 1/fuser motors	1	TG_CART1_FG	2	TG_CART1_HALL_U
	3	+5V_SW	4	TG_CART1_HALL_V
	5	Ground	6	TG_CART1_HALL_W
	7	Ground	8	GD_FUSER_HALL_W
	9	+5V_SW	10	GD_FUSER_HALL_V
	11	GD_FUSER_FG	12	GD_FUSER_HALL_U
JCARTS2 Cartridge 2/cartridge 3 motors	1	TG_CART3_FG	2	TG_CART3_HALL_U
	3	+5V_SW	4	TG_CART3_HALL_V
	5	Ground	6	TG_CART3_HALL_W
	7	Ground	8	TG_CART2_HALL_W
	9	+5V_SW	10	TG_CART2_HALL_V
	11	TG_CART2_FG	12	TG_CART2_HALL_U
JCONF1 Processor speed	1	PLL_CFG1		
	2	+1.8 V dc		
	3	PLL_CFG2		
JCVR1 Cover open switch (25 V)	1	V48_25V_CVR		
	2	V48_25VD_CVR		
JDVR1 TBM stepper/CAM driver	1	+25VE	2	+25VE
	3	+5V_FUSED	4	Ground
	5	+3.3V_ENG	6	GD_TBM_DIR
	7	GD_TBM_RESET	8	GD_TBM_ENABLE
	9	GD_TBM_REF_CLK	10	Ground
	11	GD_TBM_PWM	12	GD_TBM_STEP_MODE
	13	GD_DOOR_CAM_PWM	14	GD_DOOR_CAM_DIR
	15	GD_CAM_CURR_SNS	16	Ground
	17	TBM_STEP_SNS	18	Ground

System board listing (continued)See **“System board”** on page 5-2.

Connector	Pin #	Signal	Pin #	Signal
JDX1 Duplex / MFP BDC motor drive	1	VS12_DUP_ENC_LED		
	2	S_DUP_MPF_ENC		
	3	Ground		
	4	V24_DUP_MPF_M-		
	5	V24_DUP_MPF_M+		
JFAN1 System fan	1	Ground		
	2	V18_FAN_MTR		
	3	S_FAN_FG		
	4	NC		
JFDPCK1 Paper Feed/Waste Toner Motor and Tray 1 Pick	1	VS12_FEED_ENC	2	V24_PICK_M+
	3	S_FEED_ENC	4	V24_PICK_M-
	5	Ground	6	Ground
	7	V24_FEED_MTR-	8	S_T1PK_ENC
	9	V24_FEED_MTR+	10	VS12_5V_ENC
JFDS1 Feed thru sensor	1	VS12_FDS		
	2	S_FDS_FB		
	3	Ground		
JFMUSB1 Front panel USB port	1	Ground		
	2	USB_DM1		
	3	USB_DP1		
	4	NC		
	5	Ground		
JFUSER1 Belt, exit, bubble sensors	1	S_FSR_BLT2_SNS	2	GD_FSR_BLT1_RTN
	3	VS_BUB_LED	4	S_FSR_BUB_SNSD
	5	Ground	6	Ground
	7	S_FSR_EXIT_SNSD	8	VS_EXIT_LED
	9	S_FSR_BLT1_SNS	10	GD_FSR_BLT1_RTN

System board listing (continued)See **“System board”** on page 5-2.

Connector	Pin #	Signal	Pin #	Signal
JHVPS1 High-voltage power supply	1	Ground	2	+25VD
	3	C-DEVPWM	4	M-DEVPWM
	5	Y-DEVPWM	6	K-DEVPWM
	7	Ground	8	+5V_SW
	9	TONER_C	10	TONER_M
	11	TONER_Y	12	TONER_K
	13	GD_HV_CHRG_PWM	14	V_SNS
	15	GD_HV_XFR_PWM_C	16	C_SRVO_OUT
	17	GD_HV_XFR_PWM_M	18	M_SRVO_OUT
	19	GD_HV_XFR_PWM_Y	20	Y_SRVO_OUT
	21	PC_SNS	22	+5V_HVPS
	23	GD_HV_XFR_PWM_K	24	K_SRVO_OUT
	25	XFER_BOOST	26	GD_HVPS_ID
JINT1 Interlock switch (5v)	1	VS24_JINT		
	2	Ground		
	3	VS24_INT		
JLVPS1 Low-voltage power supply	1	+24V_AIO		
	2	+24V_AIO		
	3	+5V_AIO		
	4	+5_AIO		
	5	Ground		
	6	Ground		
JLVPS2 Low-voltage power supply	1	+5 V dc	2	+5 V dc
	3	+5 V dc	4	GD_LVPS_0X
	5	+25 V dc	6	+25 V dc
	7	Ground	8	Ground
	9	Ground	10	Ground
	11	V15_LVPS_FSR_RLY	12	GD_LVPS_HRON
JMIRR1 Mirror motor	1	MM_REFR		
	2	TG_MM_LOCK		
	3	TG_MM_START		
	4	Ground		
	5	+25VC		

System board listing (continued)

 See **“System board”** on page 5-2.

Connector	Pin #	Signal	Pin #	Signal
JOPP1 Operator panel (12C)	1	I2C_DATA		
	2	V12_PANEL+5V		
	3	I2C_CLK		
	4	Ground		
	5	TG_OP_IRQ-		
	6	+3.3 V dc		
	7	Ground		
JOPT1 Option port	1	+25VE	2	Ground
	3	S_OPT_RXR	4	Ground
	5	S_INPUT_FDT	6	VS24_OPT_5V
	7	Ground	8	S_OPT_TXR
JPH1 Printhead	1	VDO_SYNC_C		
	2	VDO_PHR_OK		
	3	VDO_SYNC_B		
	4	VDO_LENA		
	5	TG_VDO_SHADE_D		
	6	VS12_+3.3VPH		
	7	TG_VDO_SHADE_C		
	8	VS12_JPH1		
	9	TG_VDO_SHADE_B		
	10	VS12_JPH1		
	11	TG_VDO_SHADE_A		
	12	Ground		
	13	D_VDO_D2+		
	14	D_VDO_D2-		
	15	Ground		
	16	D_VDO_D+		
	17	D_VDO_D-		
	18	Ground		
	19	D_VDO_C2+		
	20	D_VDO_C2-		
	21	Ground		
	22	D_VDO_C+		
	23	D_VDO_C-		
	24	Ground		
	25	D_VDO_B2+		
	26	D_VDO_B3-		
	27	Ground		

System board listing (continued)

See "System board" on page 5-2.

Connector	Pin #	Signal	Pin #	Signal
JPH1 Printhead (continued)	28	D_VDO_B+		
	29	D_VDO_B-		
	30	Ground		
	31	D_VDO_A2+		
	32	D_VDO_A2-		
	33	Ground		
	34	D_VDO_A+		
	35	D_VDO_A-		
	36	Ground		
	37	I2C_CLK_PH		
	38	TG_VDO_LADJ_CD		
	39	I2C_DATA_PH		
	40	TG_VDO_LADJ_AB		
JSB1 Cartridge SB	1	S_SB_Y		
	2	Ground		
	3	S_SB_C		
	4	Ground		
	5	S_SB_M		
	6	Ground		
	7	S_SB_K		
	8	Ground		
JSEC1 Security jumper	1	V2		
	2	Ground		
	3	Ground		
JT1 Test Connector	1	Ground		
	2	Ground		
JT12 Manual Reset	1	MAX811_MR_		
	2	Ground		
JTDEBUG1 Debug	1	GD_DEBUG		
	2	Ground		
JTLBT1 LB trace port	1	Ground		
	2	TG_WF_RXD		
	3	TG_WF_TXD		
	4	+5 V dc or Ground		

System board listing (continued)See **“System board”** on page 5-2.

Connector	Pin #	Signal	Pin #	Signal
JTPS1 Toner Patch Sensor	1	V12_LED_ON	2	VS12_3_3V
	3	GD_TPS_SNS	4	GD_TPS_PWM1
	5	GD_TPS_SNS_RTN	6	GD_TPS_TNR_SNS
	7	Ground	8	I2C_CLK_TB
	9	I2C_DATA_TB	10	GD_TPS_THERM_SNS
JTRAY1 Tray 1 input, NMT sensors	1	Ground		
	2	S_TRAY_INPUT		
	3	VS12_TRAY_INPT_LED		
	4	VS12_TRAY+5V_NMT		
	5	S_TRAY_NMT		
	6	Ground		
JTWF1 Winflex serial port (engine)	1	Ground		
	2	TG_RXD1		
	3	TG_TXD1		
	4	+5 V dc or Ground		
JUSB1 USB device port	1	USB_DEV_VBUS_R		
	2	USB_DEVD-		
	3	USB_DEVD+		
	4	Ground		
	G1	Ground		
	G2	Ground		
JUSB2 Back USB port	1	+5 V dc		
	2	USB_DM3		
	3	USB_DP3		
	4	NC		
	5	Ground		

6. Preventive maintenance

This chapter describes procedures for printer preventive maintenance. Follow these recommendations to help prevent problems and maintain optimum performance.

Safety inspection guide

The purpose of this inspection guide is to aid you in identifying unsafe conditions.

If any unsafe conditions exist, find out how serious the hazard could be and if you can continue before you correct the hazard.

Check the following items:

- Damaged, missing, or altered parts, especially in the area of the On/Off switch and the power supply
- Damaged, missing, or altered covers, especially in the area of the top cover and the power supply cover
- Possible safety exposure from any non-Lexmark attachments

Lubrication specifications

Lubricate only when parts are replaced or as needed, not on a scheduled basis. Use of lubricants other than those specified can cause premature failure. Some unauthorized lubricants may chemically attack polycarbonate parts. Use IBM no. 10 oil, P/N 1280443 (Approved equivalents: Mobil DTE27, Shell Tellus 100, Fuchs Renolin MR30), IBM no. 23 grease (Approved equivalent Shell Darina 1), and grease, P/N 99A0394 to lubricate appropriate areas. Use Nyogel type 774 to lubricate the Fuser Drive Assembly and Nyogel 744 to lubricate the ITU and Cartridge Drive assemblies.

Maintenance

Cleaning the scanner glass

Clean the scanner glass if you encounter print quality problems, such as streaks on copied or scanned images.

1. Slightly dampen a soft, lint-free cloth or paper towel with water.
2. Open the scanner cover.

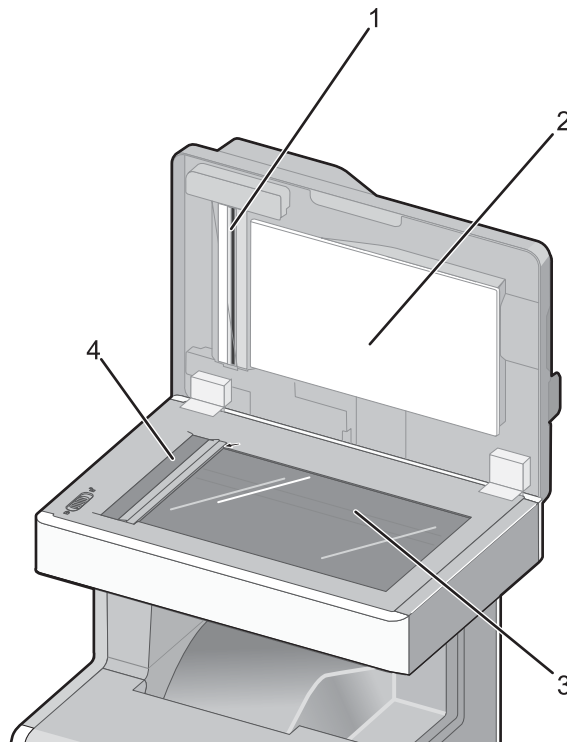

1	White underside of the ADF cover
2	White pressure plate cover
3	Scanner glass
4	ADF glass

3. Wipe the areas shown, and let them dry.
4. Close the scanner cover.

Cleaning the ADF parts

Clean the ADF parts periodically to maintain optimal printing performance. Residue on the ADF parts may cause print quality issues and false 290–294 paper jam messages.

1. Turn the printer off.
2. Slightly dampen a soft, lint-free cloth with water.
3. Open the ADF cover.
4. Remove the pick roller assembly.

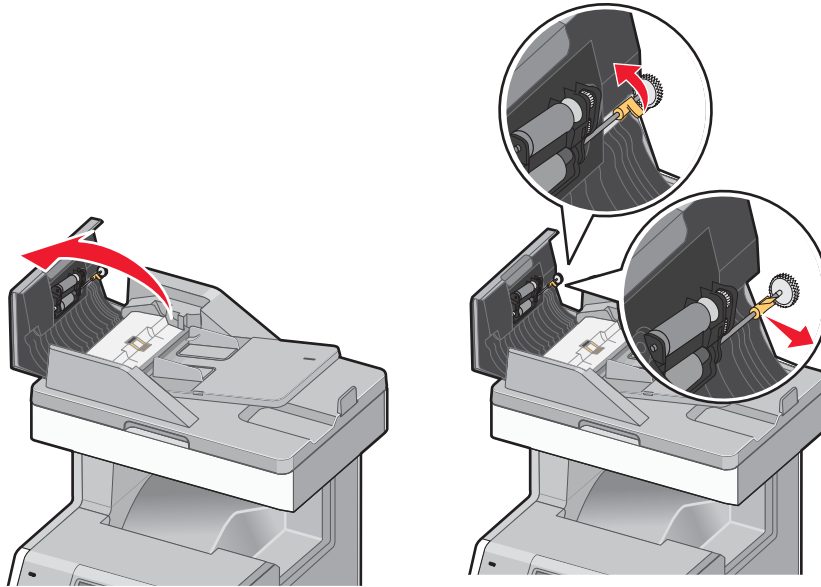

5. Wipe the surface of both pick rollers.
6. Replace the pick roller assembly.

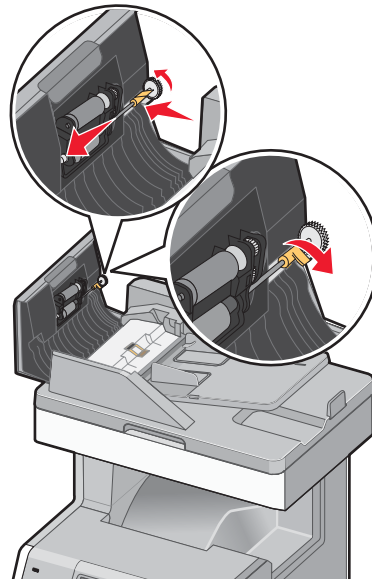

7. Wipe the entire surface under the ADF cover, including the two small white rollers.
8. Wipe the separator pad, and then wipe the pick pad.

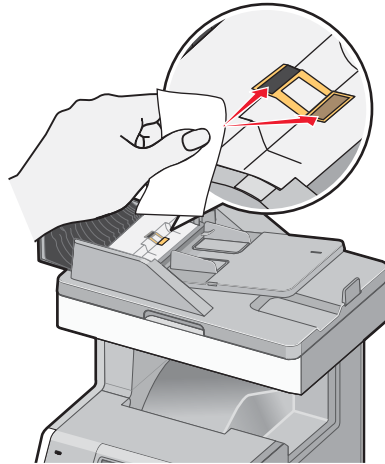

9. Pull the flap up as shown, and then wipe the sensor behind it.

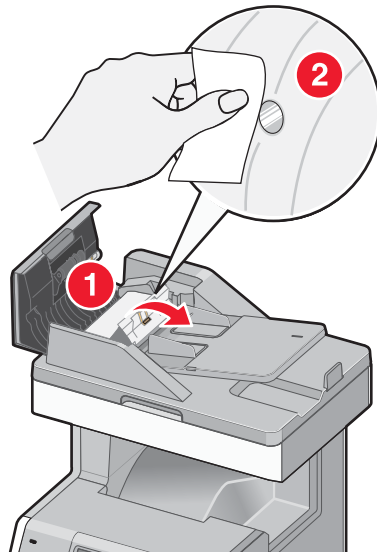

10. Close the flap, and then close the ADF cover.

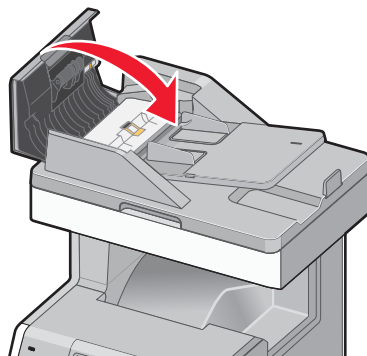

Cleaning the printhead lenses

Clean the printhead lenses when you encounter print quality problems.

1. Turn the printer off, and disconnect the power cord.
2. Open the upper front door, and then open the lower front door.
Warning: Potential Damage—To avoid overexposing the photoconductors, do not leave the front doors open for more than 10 minutes.
3. Remove all four toner cartridges. Do not remove the photoconductors for this procedure.
4. Locate the four printhead lenses.

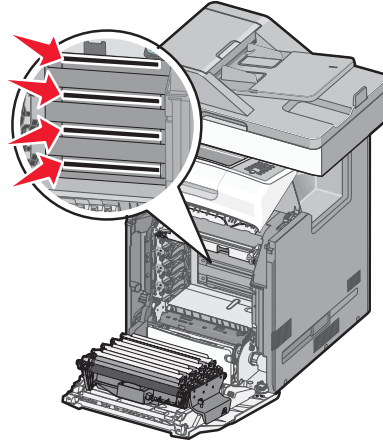

5. Clean the lenses using a can of compressed air.
Warning: Potential Damage—Do not touch the printhead lenses.
6. Reinstall the four toner cartridges.
7. Close the lower front door, and then close the upper front door.

Spare ADF supplies

The printer comes with a spare separator pad and flatbed air filter, located under the scanner. To access the spare parts, remove the slotted screw.

Note: It is recommended that the ADF area and parts be cleaned periodically.

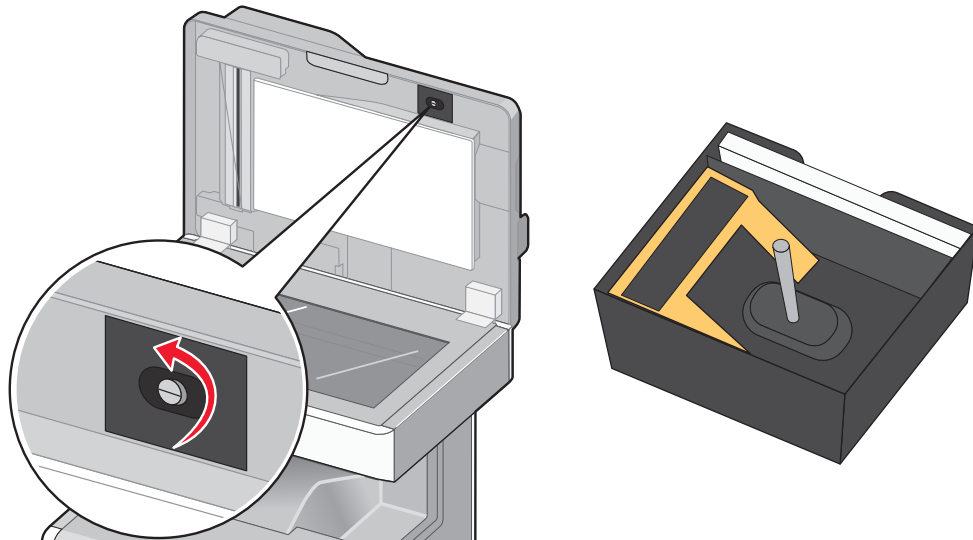

7. Parts catalog

How to use this parts catalog

The following legend is used in the parts catalog:

Asm-index	Part number	Units/mach	Units/FRU	Description
-----------	-------------	------------	-----------	-------------

- **Asm-index:** Identifies the assembly and the item in the diagram. For example, 3-1 indicates Assembly 3 and item number 1 in the table.
- **Part number:** Identifies the unique number that identifies this FRU.
- **Units/mach:** Refers to the number of units actually used in the base machine or product.
- **Units/option:** Refers to the number of units in a particular option. It does not include the rest of the base machine.
- **Units/FRU:** Refers to the number of units packaged together and identified by the part number.
- **NS:** (Not shown) in the Asm-Index column indicates that the part is procurable but is not pictured in the illustration.
- Model information used in the parts catalog:

Abbreviation used	Machine type/model	Model name	Description
235	7526-235	Lexmark X734de	4-in-1 Color MFP
275	7526-275	Lexmark X734de	4-in-1 Color MFP, with fax modem
295	7526-295	Lexmark X734de	4-in-1 Color MFP, with fax modem
436	7526-436	Lexmark X736de	4-in-1 Color MFP
476	7526-476	Lexmark X736de	4-in-1 Color MFP with fax modem
496	7526-496	Lexmark X736de	4-in-1 Color MFP, with fax modem
636	7526-636	Lexmark X738de	4-in-1 Color MFP
676	7526-676	Lexmark X738de, dte	4-in-1 Color MFP with fax modem

Assembly 1: Covers—printer

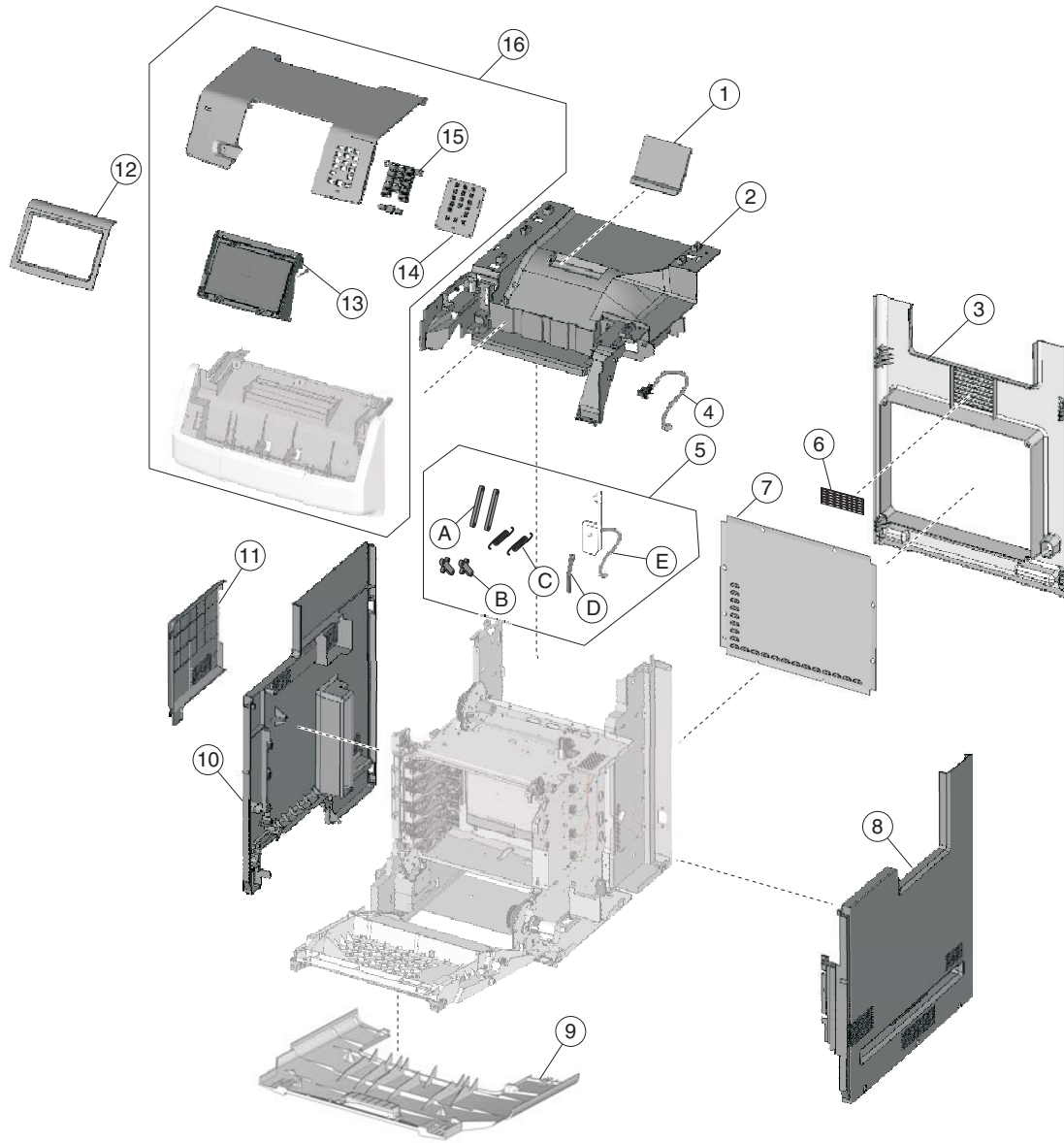

Assembly 1: Covers—Printer

Index	P/N	Units/ mach	Units/ FRU	Description
1—1	40X5164	1	1	Output bin extension cover
2	40X5175	1	1	Top cover assembly
3	40X5174	1	1	Rear cover
4	40X5121	1	1	Top access cover sensor
5		1	1	Parts package (top access cover) (P/N 40X5180), including A—Link (top access cover) (2) B—Link (top cover) (2) D—Top access cover links (slider cam) (1) C—Top access door link spring (2) E—Bin full sensor with cable and flag (1)
6	40X5287	1	1	Cooling fan filter
7	40X5169	1	1	Rear frame cover
8	40X5172	1	1	Right cover
9	40X5112	1	1	Front access door cover assembly
10	40X5173	1	1	Left cover
11	40X5221	1	1	Left door cover
12	40X5177	1	1	Operator panel bezel, 235, 275
12	40X5178	1	1	Operator panel bezel, 436, 476
12	40X5222	1	1	Operator panel bezel, 636, 676
12	40X5288	1	1	Operator panel bezel, 496
12	40X5289	1	1	Operator panel bezel, 295
13	40X5179	1	1	Operator panel assembly, with card
14	40X5186	1	1	UICC card
15	40X5181	1	1	Parts packet (operator panel buttons)
16	40X5176	1	1	Top access cover assembly

Assembly 2: Front

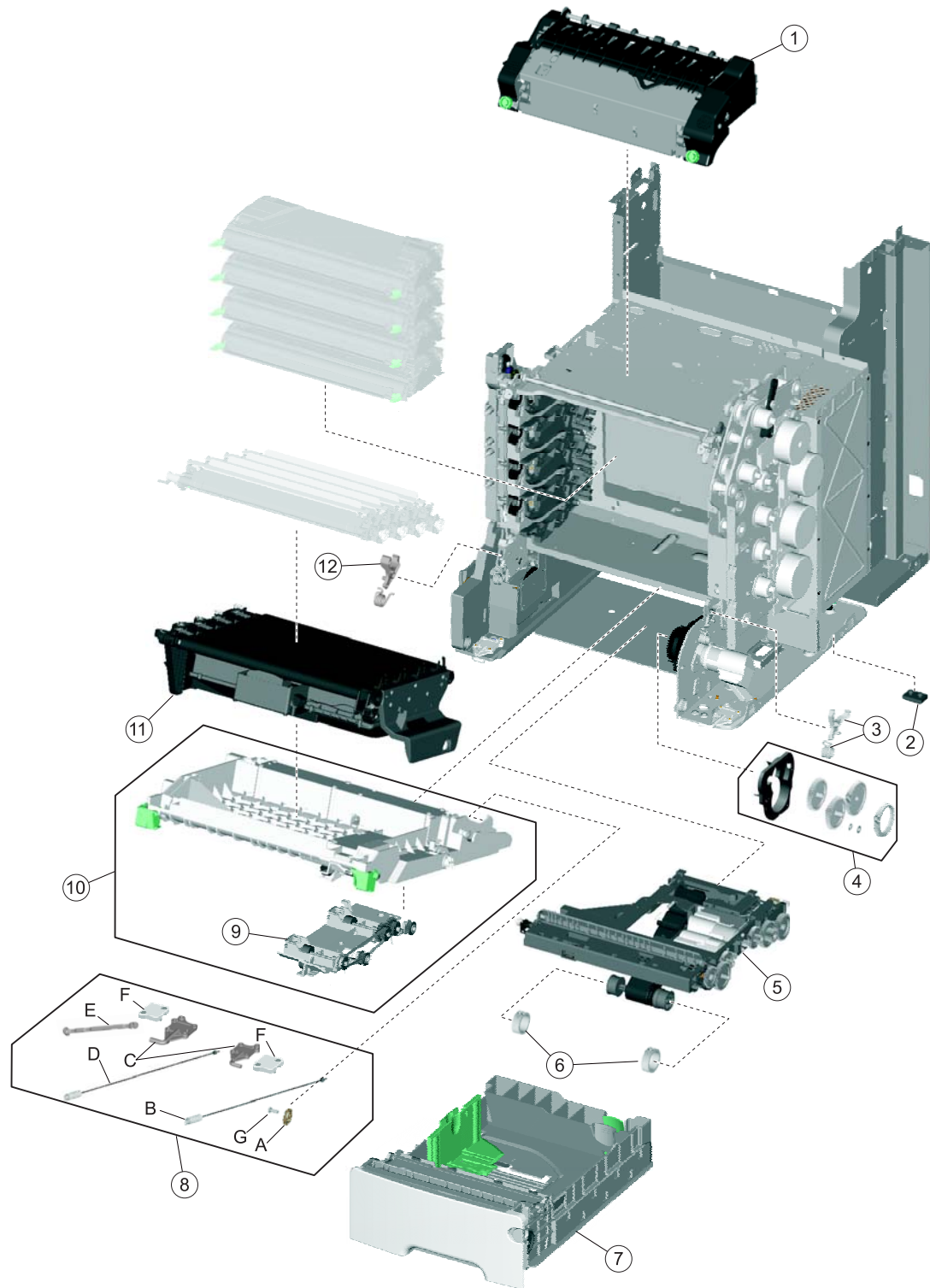

Assembly 2: Front

Index	P/N	Units/ mach	Units/ FRU	Description
2—1	40X5093	1	1	Fuser assembly, 115 V
1	40X5094	1	1	Fuser assembly, 230 V
1	40X5095	1	1	Fuser assembly, 100 V
2		6	1	Printer pad, included in parts packet, screws (P/N 40X5136)
3	40X1446	1	1	Right bellcrank assembly, with spring
4	40X5132	1	1	Parts packet, MP feeder/duplex drive, including: <ul style="list-style-type: none"> • Retainer release arm • Grease packet (Nyogel 744) • Washer • Duplex engagement gear • MP feeder reduction gear • MP feeder/duplex reduction gear • MP feeder drive cover
5	40X5275	1	1	Paper pick assembly
6	40X5168	2	2	Pick tire
7	40X5273	1	1	Paper tray assembly, 550-sheet
8	40X5111	1	1	Parts packet, front door, including: <ul style="list-style-type: none"> • A—Front access door cap (1) • B—Right cable assembly (1) • C—Front access cover pivot (1) • D—Left cable assembly (1) • E—Front access door straps (2) • F—Front access door bracket (1) • G—Screw
9	40X5113	1	1	Duplex reference edge assembly
10	40X5184	1	1	Front access door assembly
11	40X5096	1	1	Transfer module
12	40X1447	1	1	Left bellcrank assembly, with spring

Assembly 3: Right

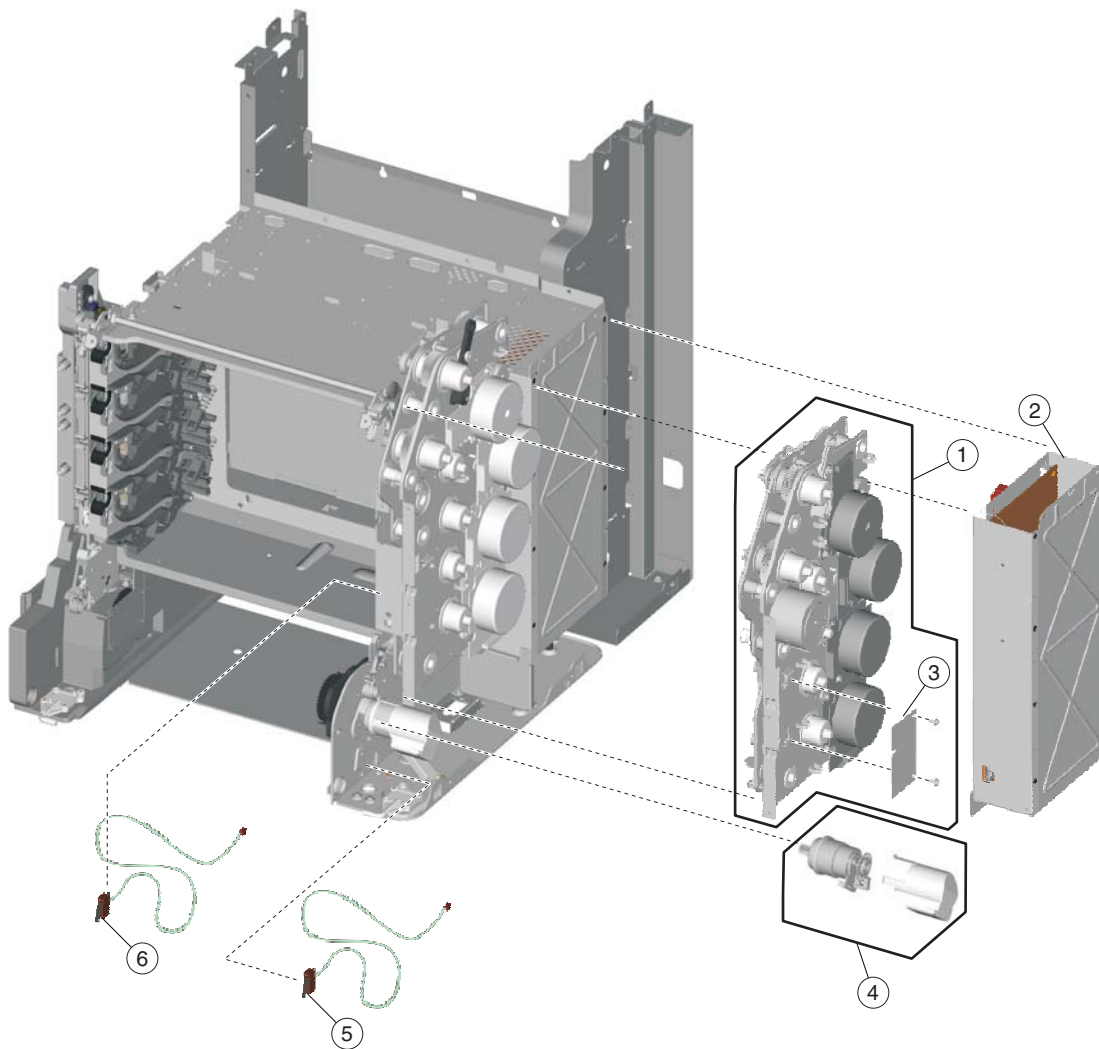

Assembly 3: Right

Index	P/N	Units/ mach	Units/ FRU	Description
3-1	40X5125	1	1	EP drive assembly
2	40X5182	1	1	Low-voltage power supply
3	40X5126	1	1	Motor driver card
4	40X5131	1	1	MP feeder/duplex motor
5	40X5128	1	1	24 V interlock switch
6	40X5127	1	1	5 V interlock switch

Assembly 4: Rear

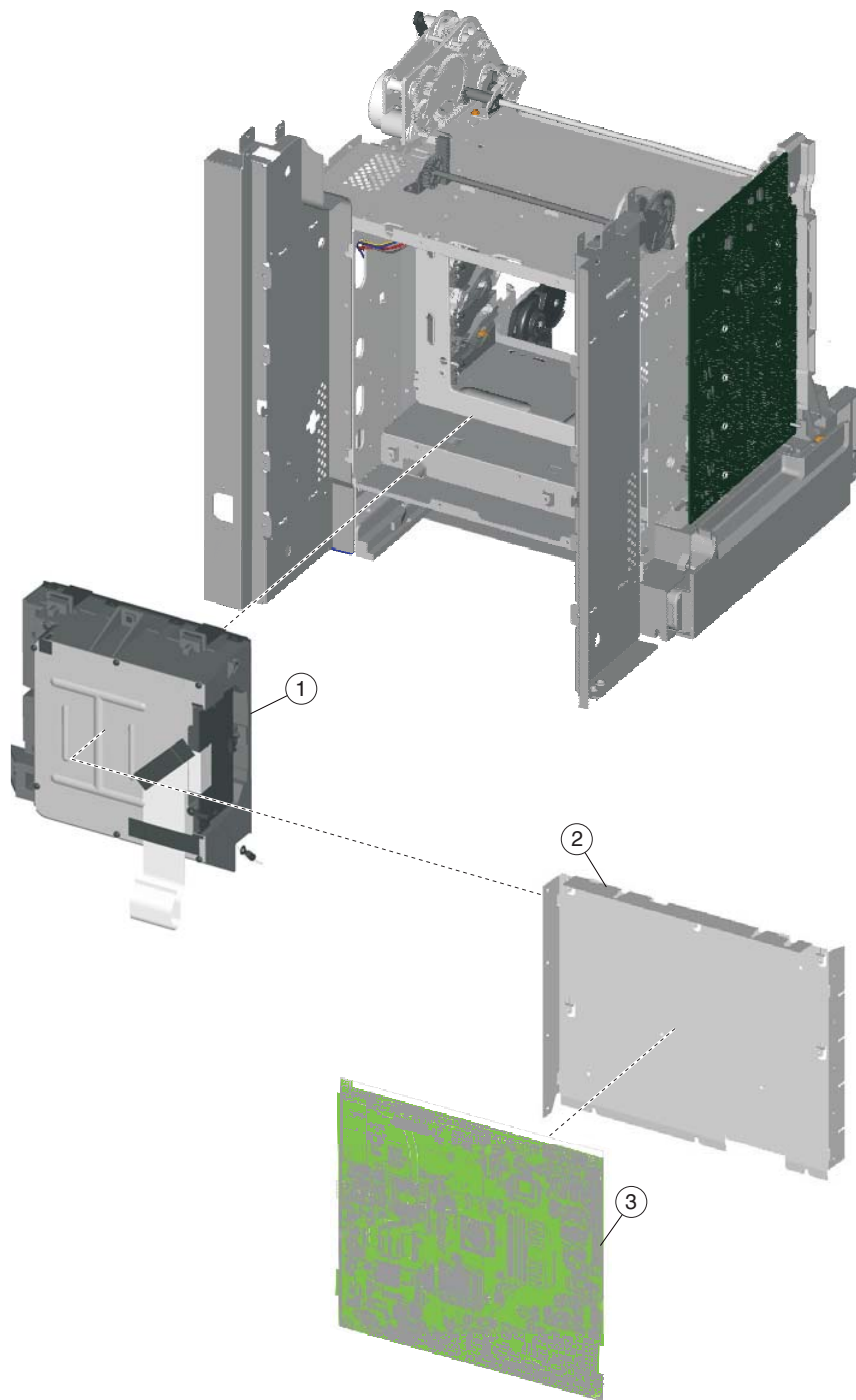

Assembly 4: Rear

Index	P/N	Units/ mach	Units/ FRU	Description
4—1	40X5123	1	1	Printhead assembly
2	40X5107	1	1	System board support shield
3	40X5200	1	1	System board (network), 235, 275, 295
3	40X5271	1	1	System board (network), 436, 476, 496, 636, 676
NS	40X0269	1	1	Power cord—USA, Canada, Bolivia, Peru
NS	40X0288	1	1	Power cord (8 ft.)—Argentina
NS	40X0301	1	1	Power cord (8 ft.)—Australia, New Zealand
NS	40X3141	1	1	Power cord (8 ft.)—Austria, Belgium, Catalan, Czechoslovakia, Finland, France, Germany, Greece, Hungary, Ireland, Italy, Netherlands, Norway, Paraguay, Poland, Portugal, Russia, Spain, Sweden, Turkey, United Kingdom
NS	40X0271	1	1	Power cord (8 ft.)—Hong Kong, Ireland, United Kingdom
NS	40X4596	1	1	Power cord (8 ft.)—Brazil
NS	40X0273	1	1	Power cord (8 ft.)—Chile, Uruguay
NS	40X0303	1	1	Power cord (8 ft.)—China
NS	40X1774	1	1	Power cord (8 ft.)—Denmark, Finland, Norway, Sweden
NS	40X0275	1	1	Power cord (8 ft.)—Israel
NS	40X3609	1	1	Power cord (8 ft.)—Japan
NS	40X1792	1	1	Power cord (8 ft.)—Korea
NS	40X1773	1	1	Power cord (8 ft.)—South Africa
NS	40X1772	1	1	Power cord (8 ft.)—Switzerland
NS	40X1791	1	1	Power cord (8 ft.)—Taiwan

Assembly 5: Left

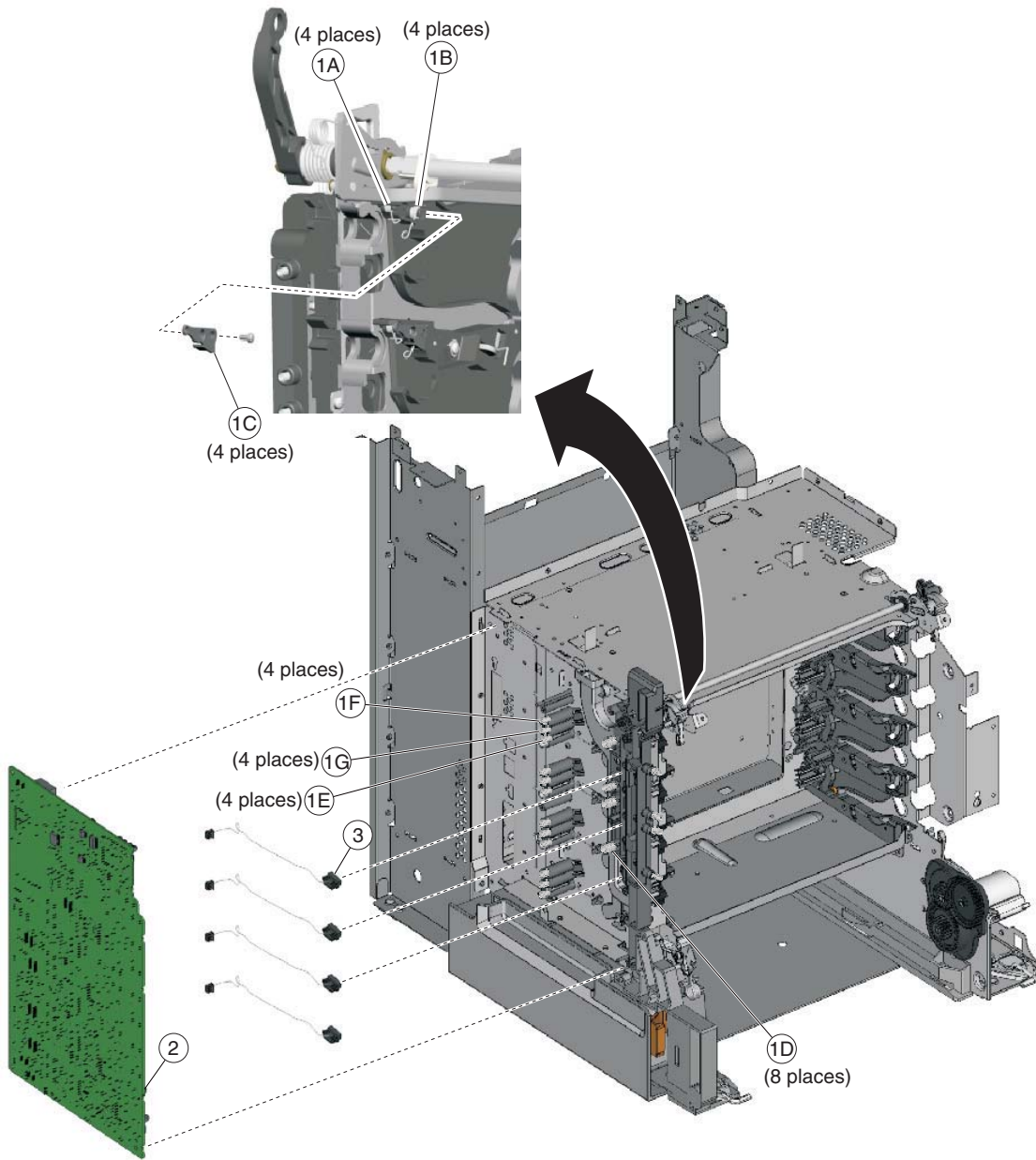

Assembly 5: Left

Index	P/N	Units/ mach	Units/ FRU	Description
5—1	40X5137	1	1	Contact springs kit, including: <ul style="list-style-type: none"> • A—Torsion PCD contact spring • B—Torsion CR contact spring • C—Contact spring cap • D—Charge roll contact spring • E—HVPS TAR contact spring • F—HVPS doctor/developer contact spring • G—HVPS Db contact spring • Screw
2	40X5129	1	1	High-voltage power supply
3	40X1416	4	1	Toner level sensor

Assembly 6: Top

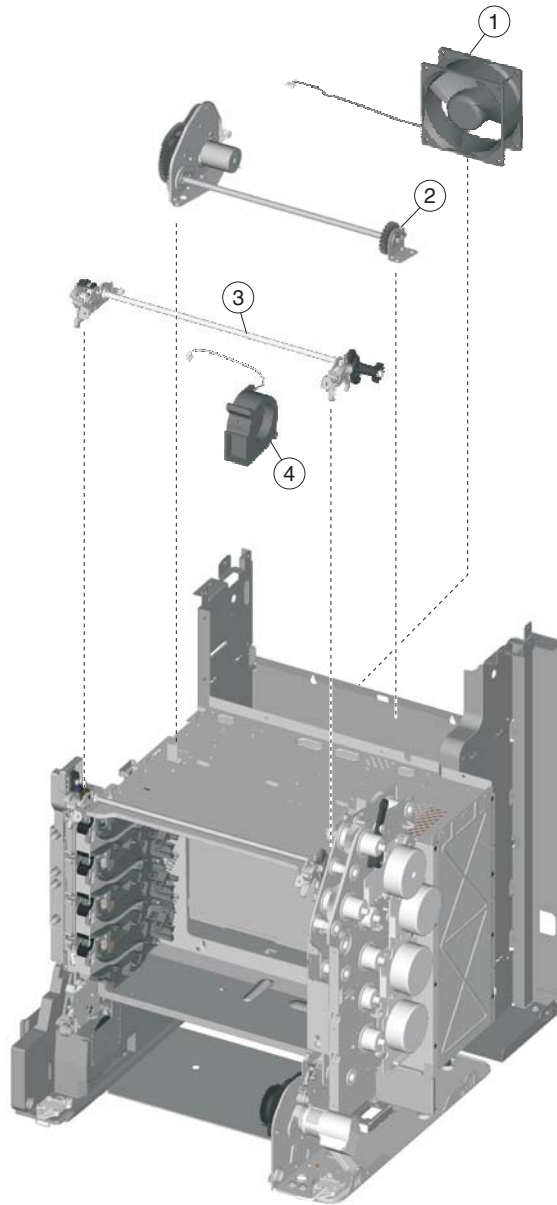

Index	P/N	Units/ mach	Units/ FRU	Description
6—1	40X5109	1	1	Cooling fan
2	40X5122	1	1	Color on demand assembly
3	40X5130	1	1	Top cover camshaft assembly
4	40X5108	1	1	Cartridge cooling fan

Assembly 7: Cable parts packet

Index	P/N	Units/ mach	Units/ FRU	Description
7—NS	40X5183	1	1	Cables, including <ul style="list-style-type: none"> • MPF/duplex motor cable (1) • High-voltage power supply • Cartridge motor 1/fuser cable (1) • Cartridge motor 2 /3 • Motor driver cable • Option cable (1) • Transport motor cable (1) • Operator panel cable • Fuser AC cable (1) • Fuser DC cable (1) • Duplex cable (1) • USB-A cable • Operator panel ground cable

Assembly 8: Covers—scanner

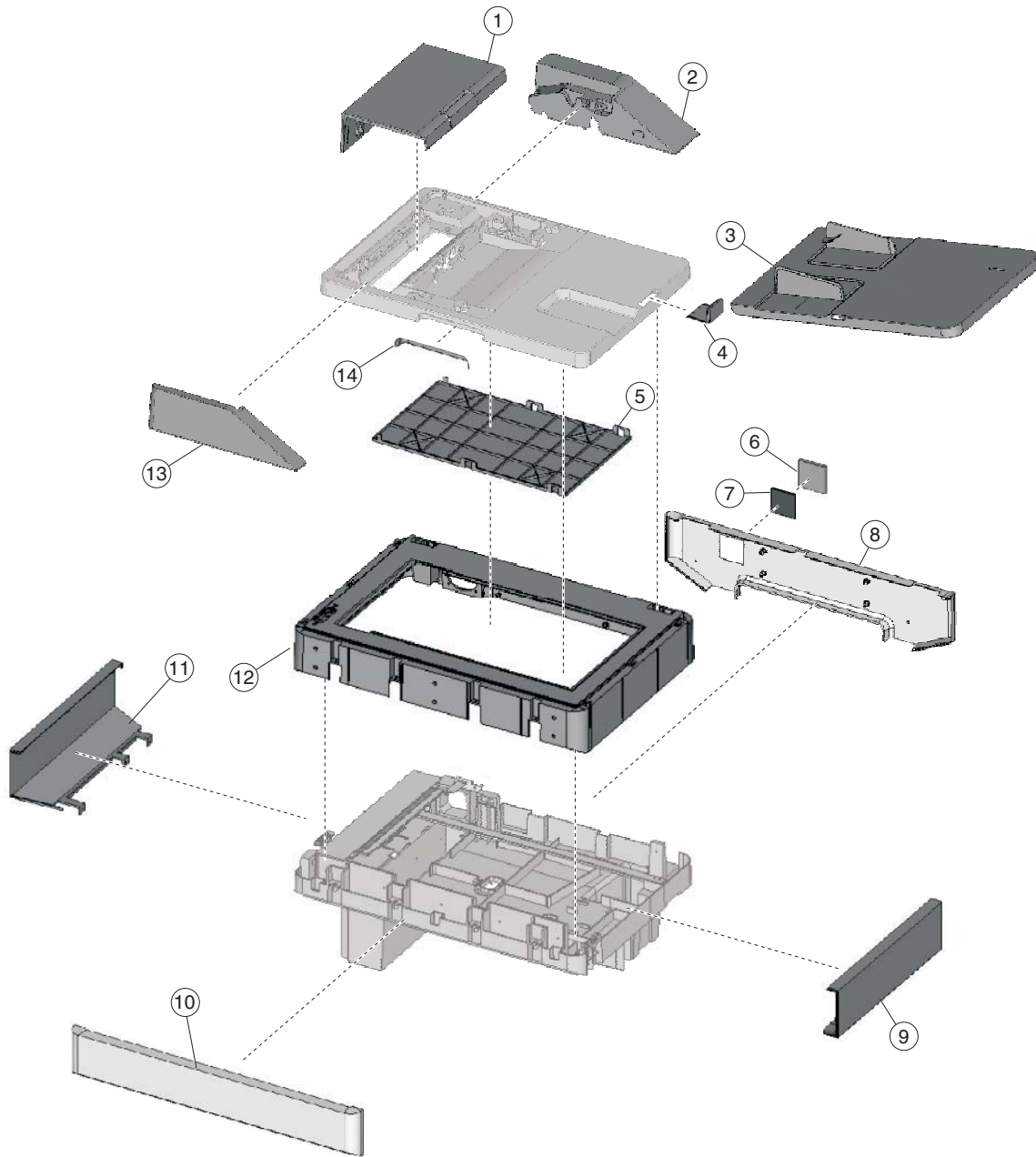

Assembly 8: Covers—Scanner

Index	P/N	Units/ mach	Units/ FRU	Description
8—1	40X5196	1	1	ADF front case cover
2	40X5202	1	1	ADF upper motor side cover
3	40X5192	1	1	ADF document input tray
4	40X5193	1	1	ADF paper stop
5	40X5194	1	1	Pressure plate cover
6	40X5198	1	1	Flatbed filter door cover
7	40X5218	1	1	Flatbed air filter
8	40X5207	1	1	Scanner rear cover
9	40X5205	1	1	Scanner right cover
10	40X5206	1	1	Scanner front cover
11	40X5204	1	1	Scanner left cover
12	40X5211	1	1	Flatbed with glass cover
13	40X5203	1	1	ADF upper front side cover
14	40X5201	1	1	ADF lid handle cover

Assembly 9: Automatic document feeder (ADF)

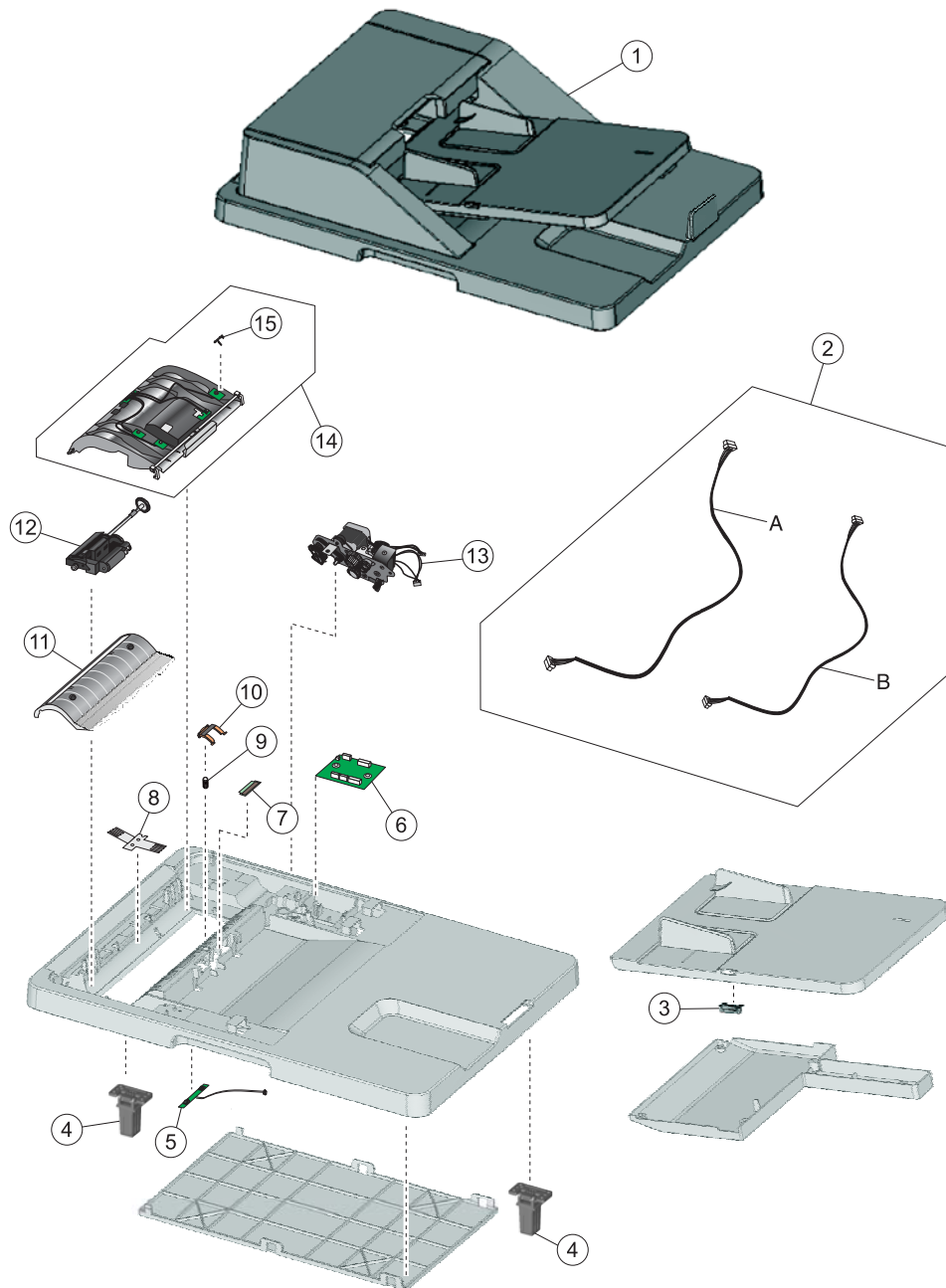

Assembly 9: Automatic document feeder (ADF)

Index	P/N	Units/ mach	Units/ FRU	Description
9—1	40X5190			ADF, complete
2		1	1	Parts packet—cables (40X5217) A—ADF input tray cable B—ADF case cable Note: Additional cables listed in assembly 10 (5 total).
3	40X5210	1	1	Paper present LED card
4	40X5209	1	1	ADF hinge (left or right)
5	40X5166	1	1	ADF exit sensor with cable
6	40X5220	1	1	Scanner ICC card
7	40X5189	1	1	ADF pick pad
8	40X5165	1	1	ADF static ground brush
9	40X5163	1	1	Separator pad spring
10	40X5187	1	1	ADF separator pad
11	40X5197	1	1	ADF upper case cover
12	40X5188	1	1	ADF pick roll assembly
13	40X5208	1	1	ADF motor gear train assembly
14	40X5195	1	1	ADF front case assembly
15	40X5191	1	1	ADF cover open flag

Assembly 10: Flatbed scanner

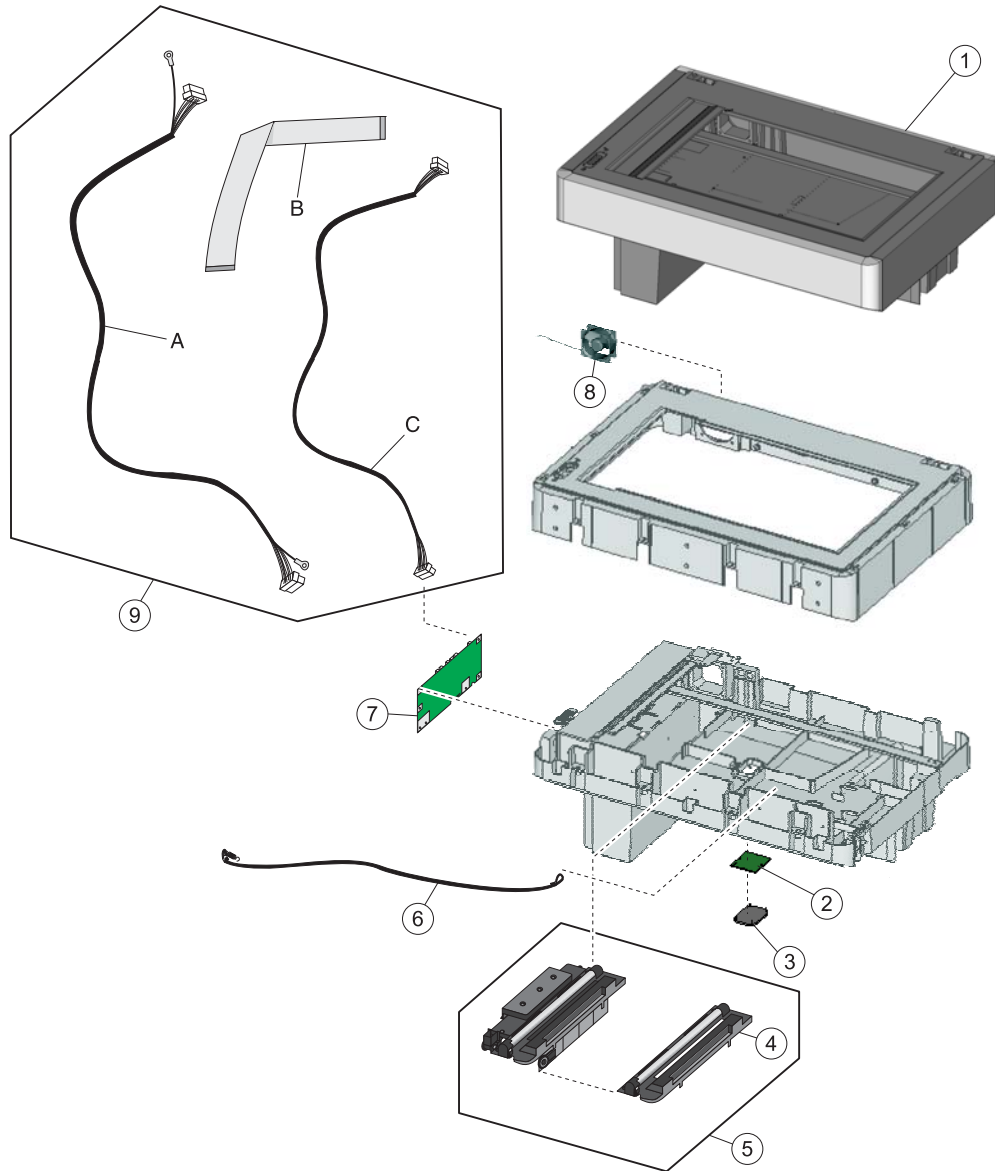

Assembly 10: Flatbed scanner

Index	P/N	Units/ mach	Units/ FRU	Description
10—1	40X5167	1	1	Flatbed scanner, complete
2	40X5215	1	1	Cave LED card
3	40X5216	1	1	Flatbed cave LED cover (clear)
4	40X5213	1	1	Flatbed CCD lamp assembly
5	40X5212	1	1	Flatbed CCD carrier module, including lamp assembly
6	40X5214	1	1	Carriage transport belt with clip
7	40X5219	1	1	Scanner MDC card
8	40X5199	1	1	Flatbed cooling fan
9		1	1	Parts packet, cables (40X5217) A—ADF cable B—Scanner to system board flat cable C—Scanner to system board cable Note: Additional cables listed in assembly 9 (5 total).

Assembly 11: Optional 550-sheet media drawer and tray

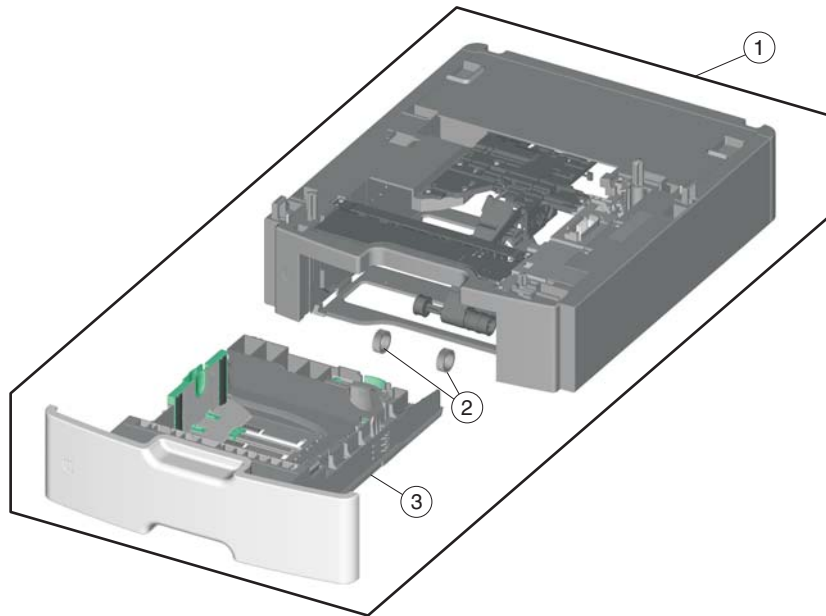

Index	P/N	Units/ opt	Units/ FRU	Description
11—1	40X5140	1	1	550-sheet tray option (drawer and tray assembly)
2	40X5168	2	2	Pick tire (550-sheet tray)
3	40X5141	1	1	550-sheet tray assembly

Assembly 12: Optional special media tray assembly

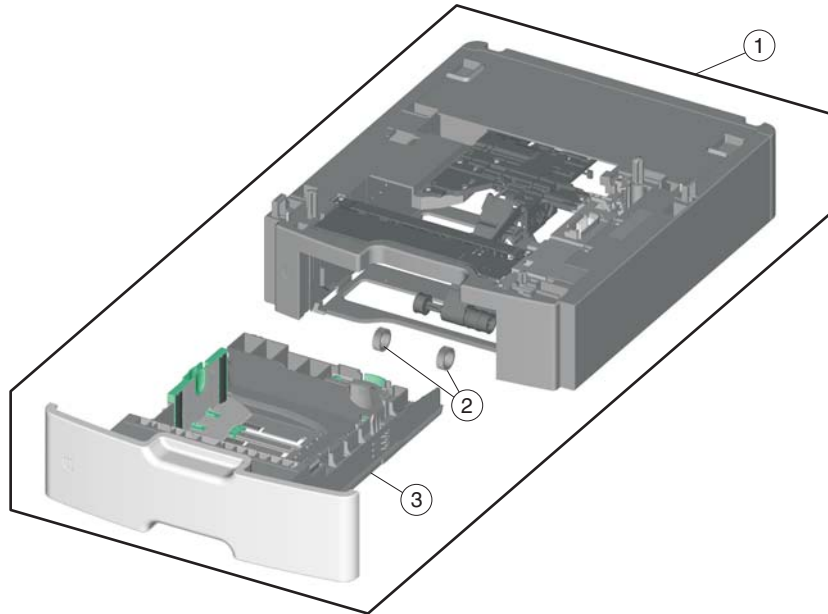

Index	P/N	Units/ opt.	Units/ FRU	Description
12—1	40X5142	1	1	Special media assembly, including tray
2	40X5152	2	2	Pick tire (550-sheet drawer)
3	40X5143	1	1	Special media tray assembly

Assembly 13: Optional high-capacity input option (HCIT)

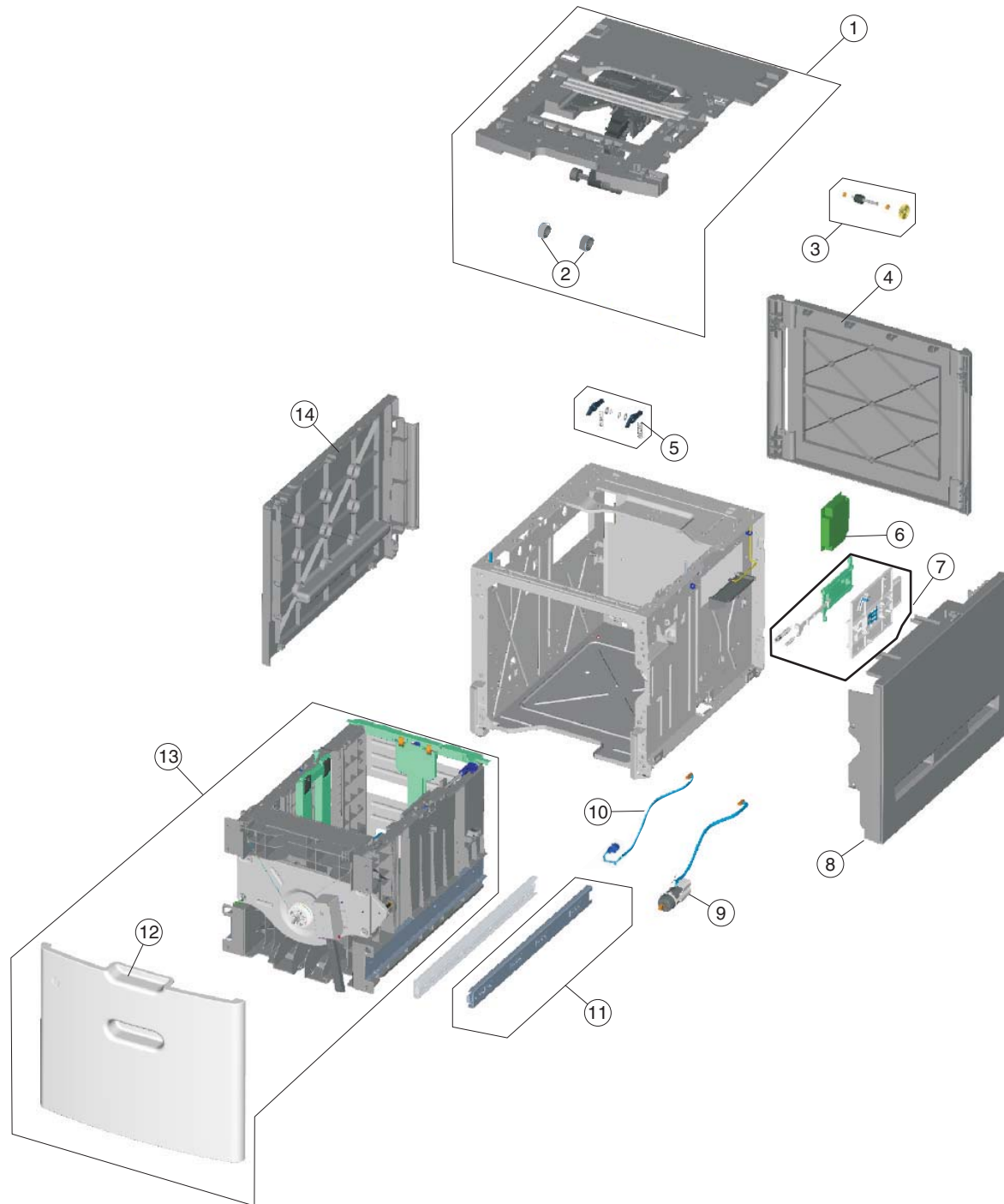

Assembly 13: Optional high-capacity input option (HCIT)

Index	P/N	Units/ option	Units/ FRU	Description
13—1	40X5157	1	1	Top plate assembly
2	40X5168	2	2	HCIT pick tire
3	40X5156	1	1	Feed with bushing
4	40X5149	1	1	HCIT rear cover
5	40X4585	2	1	Tray latch with spring
6	40X5159	1	1	HCIT controller card assembly
7	40X4587	1	1	Slide assembly with springs
8	40X5147	1	1	HCIT right cover
9	40X5155	1	1	Elevator motor with sensor
10	40X5158	1	1	Photointerrupter sensor with cable assembly
11	40X4593	2	1	HCIT drawer slide assembly
12	40X5146	1	1	HCIT front tray cover
13	40X5144	1	1	HCIT paper drawer tray assembly
14	40X5148	1	1	HCIT left cover

Assembly 14: Options and features

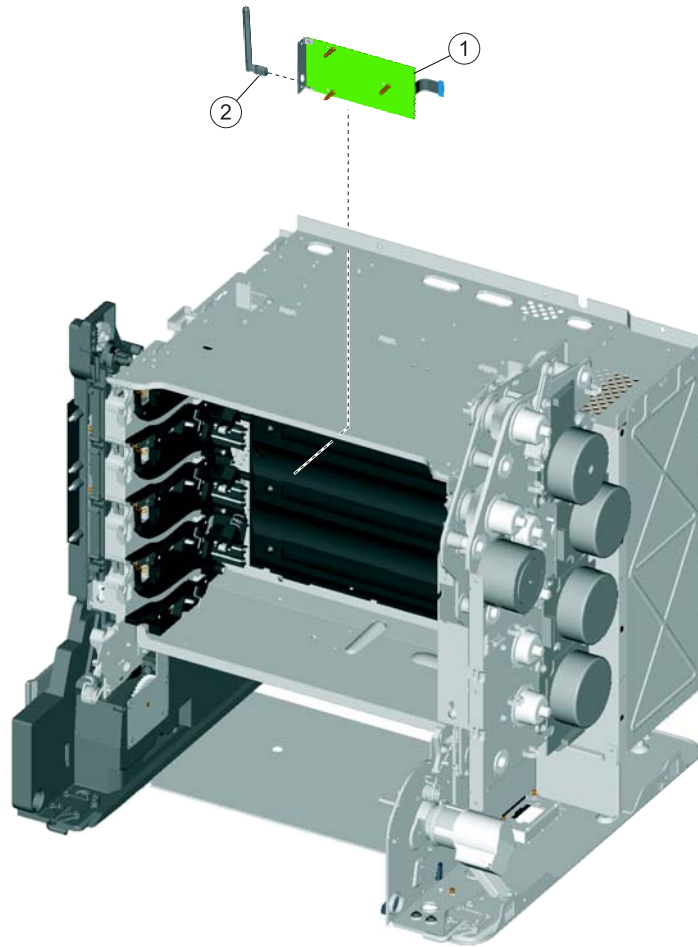

Assembly 14: Options and features

Index	P/N	Units/ mach	Units/ FRU	Description
14—1	40X5038	1	1	Wireless network card (802.11g), US/Americas
1	40X5039	1	1	Wireless network card (802.11g), rest of world
2	40X5319	1	1	Wireless antenna (802.11)
NS	40X4821	1	1	Fax modem card
NS	40X5317	1	1	Parts packet, ISP thumbscrew and standoff
NS	40X5315	1	1	ISP thumbscrew
NS	40X5318	1	1	Wireless ISP thumbscrew
NS	40X5185	1	1	Parts packet, scanner screws (contains screws used in the scanner, with the exception of parts specifically called out). See “Screw and retainer identification table” on page 4-3.
NS	40X5136	1	1	Parts packet, screws (contains screws used in the printer, with the exception of the parts specifically called out.). See “Screw and retainer identification table” on page 4-3.
NS	40X5301	1	1	256 MB SDRAM, 100-pin
NS	40X5302	1	1	512 MB SDRAM, 100-pin
NS	40X5303	1	1	1024 MB SDRAM, 100-pin
NS	40X5704	1	1	256 MB flash card
NS	40X5969	1	1	Korean font card
NS	40X5971	1	1	Traditional Chinese font card
NS	40X5970	1	1	Simplified Chinese font card
NS	40X5972	1	1	Japanese font card
NS	40X0047	1	1	Bar code and Forms card
NS	40X5952	1	1	Lexmark PrintCryption™ card
NS	40X4826	1	1	MarkNet™ N8120 10/1000
NS	40X4827	1	1	MarkNet N8130 10/100 fiber
NS	40X4823	1	1	Parallel 1284-B interface card adapter
NS	40X4819	1	1	Serial interface card adapter
NS	40X4822	1	1	80.0 GB hard drive assembly
NS	40X5285	1	1	Printer relocation kit
NS	7377200	1	1	Option drawer relocation kit
NS	40X5281	1	1	High-capacity input tray (HCIT) relocation kit
NS	40X5316	1	1	14-pin JST cable assembly for ISP interface cable
NS	40X5606	1	1	14-pin JST cable assembly for fax modem card
NS	40X0088	1	1	Card for IPDS and SCS/TNe
NS	40X4597	1	1	Card reader cable
NS	40X4598	1	1	Smart card cover
NS	40X4602	1	1	3121 Card reader card
NS	40X4603	1	1	5121 Card reader card
NS	40X4604	1	1	5125 card reader card

Index

Numerics

- 1xx service error codes **2-17–2-19**
- 24 V interlock switch
 - removal **4-50**
- 2xx paper jam codes **2-19–2-30**
- 3x–8x attendance messages **2-9–2-16**
- 5 V interlock switch
 - cable removal **4-48**
 - parts catalog **7-6**
- 8xx scanner errors **2-32–2-33**
- 9xx service error codes **2-33–2-39**
- 24 V interlock switch
 - parts catalog **7-6**

A

- acronyms **1-15**
- ADF
 - ADF exit sensor **4-216**
 - ADF front side cover, removal **4-192**
 - ADF handle cover **4-193**
 - ADF motor side cover **4-194**
 - ADF removal **4-210**
 - ADF upper case cover **4-197**
 - case assembly **4-213**
 - cleaning **6-3**
 - closed cover flag **4-215**
 - ESD brush **4-230**
 - front cover, removal **4-190**
 - hinge removal **4-218**
 - motor gear train **4-219**
 - paper stop **4-223**
 - parts catalog **7-16**
 - pick pad **4-223**
 - pick pad spring **4-224**
 - pick roller assembly **4-224**
 - pressure plate cover **4-226**
 - separator pad **4-228**
 - spare supplies **6-5**
 - specifications **1-3**
- adjustments **4-9**
- Align Motor Test **3-12**
- alignment
 - diagnostics menu **3-11**
 - printhead **4-9**
- Auto Align Adj **3-40**
- Auto Color Adj **3-40**
- autocompensator
 - See paper pick mechanism

B

- bellcrank
 - left bellcrank **4-103**
 - parts catalog **7-5**
 - right bellcrank **4-147**

- bezel
 - parts catalog **7-2**
 - removal **4-31**
- bin full sensor assembly, removal **4-52**
- Black Only Mode **3-32**
- black only retract (BOR), see color on demand assembly
- blower fan, see cartridge cooling fan
- Button Test **3-15**
- buttons
 - description **2-2**
 - removals **4-32**
- buttons, operator panel **4-32**

C

- cables
 - cartridge motor 1/fuser **4-55**
 - cartridge motor 2/3 cable **4-57**
 - fuser AC **4-95**
 - fuser DC **4-97**
 - HVPS cable **4-102**
 - motor driver cable **4-106**
 - MP feeder/duplex motor **4-114**
 - option cable **4-115**
 - transport cable **4-170**
 - transport motor cable **4-173**
 - USB connector **4-182**
- cables, parts catalog **7-13**
- cam
 - service check **2-56**
- camshaft, top cover **4-162**
- cartridge cooling fan **4-53**
 - parts catalog **7-12**
 - service check **2-127**
- cartridge motor 1/fuser cable **4-55**
- cartridge motor 2/3 cable, removal **4-57**
- cleaning
 - ADF **6-3**
 - printhead lenses **6-5**
 - scanner glass **6-2**
- Color Alignment **3-41**
- Color Lock Out **3-32**
- color on demand
 - parts catalog **7-12**
- Color On Demand (COD)
 - service check **2-58**
- color on demand assembly
 - removal **4-59**
- Color Trapping **3-33**
- configuration ID **3-25**
- configuration menu
 - accessing **3-1**
 - Auto Align Adj **3-40**
 - Auto Color Adj **3-40**
 - available tests **3-30**
 - Color Alignment **3-41**

- Color Lock Out **3-32**
- Color Trapping **3-33**
- Disk Encryption **3-44**
- Download Emuls **3-34**
- Duplex Gloss **3-43**
- Energy Conserve **3-35**
- Enforce Color Order **3-41**
- Env Prompts **3-42**
- Event Log **3-33**
- exit Config Menu **3-47**
- Factory Defaults **3-35**
- Fax Storage Location **3-37**
- Font Sharpening **3-46**
- Format Fax Storage **3-36**
- Jobs on Disk **3-43**
- Min Copy Memory **3-36**
- Motor Calibration **3-42**
- Numpad Job Assist **3-36**
- Panel Menus **3-34**
- Paper Prompts **3-42**
- PPDS Emulation **3-34**
- Prt Quality Pages **3-32**
- Reset Fuser Cnt **3-31**
- Size Sensing **3-33**
- USB Scan to Local **3-31**
- contact springs
 - parts catalog **7-10**
 - removal **4-63**
- control panel, see operator panel
- cooling fan
 - parts catalog **7-2, 7-12**
 - removal **4-65**
- cooling fan filter
 - parts catalog **7-2**
- covers
 - multifunction printer **4-20**
 - parts catalog **7-2**
 - scanner **7-14**
 - scanner flatbed and ADF **4-190**

D

- dead printer service check **2-140**
- defaults **3-23**
 - EP Defaults **3-26**
 - factory defaults **3-35**
- diagnostics menu
 - accessing **3-1**
 - ALIGNMENT **3-11**
 - available tests **3-3**
 - Device Tests
 - Disk Test/Clean **3-23**
 - Flash Test **3-23**
 - Quick Disk Test **3-22**
 - Duplex Tests
 - Print Test (duplex) **3-19**
 - Quick Test **3-18**
 - Top Margin **3-20**

- Event Log
 - Clear Log **3-29**
 - Display Log **3-28**
 - Print Log **3-28**
- exit diagnostics **3-29**
- Hardware Tests
 - Button Test **3-15**
 - DRAM Test **3-16**
 - Panel Test **3-15**
- Motor Tests
 - Align Motor Test **3-12**
 - Fuser **3-12**
 - Mirror Motor Test **3-22**
 - Motor Calibration **3-26**
 - Servo Laser Test **3-22**
 - Transfer **3-12**
 - Tray 1 **3-12**
- Print Tests
 - input source tests **3-13**
 - Prt Quality Pgs **3-14**
- Printer Setup
 - Configuration ID **3-25**
 - DC Charge Adjust **3-27**
 - Defaults **3-23**
 - Dev Bias Adj **3-27**
 - Engine Setting 1–4 **3-24**
 - EP Defaults **3-26**
 - Fuser Temp **3-27**
 - Model Name **3-24**
 - Page Counts **3-24**
 - Reset Calibration **3-26**
 - Serial Number **3-24**
 - Transfer Adjust **3-27**
- Registration **3-6**
 - Bottom Margin **3-7**
 - Left Margin **3-7**
 - Quick Test **3-8**
 - Right Margin **3-7**
 - Skew **3-6**
 - Top Margin **3-7**
- Scanner Tests
 - ASIC Test **3-9**
 - Feed Test **3-9**
 - Sensor Test **3-10**
- Sensor Tests **3-21**
- Disk Encryption **3-44**
- DRAM Test **3-16**
- duplex
 - duplex reference edge guide assembly **4-67**
 - gear and housing removal **4-108**
 - motor assembly removal **4-110**
 - motor cable removal **4-114**
 - multipurpose feeder/duplex motor assembly **4-110**
 - Print Test **3-19**
 - Quick Test **3-18**
 - service check **2-53**
 - Top Margin **3-20**
- Duplex Gloss **3-43**

duplex motor cable, removal **4-114**
 duplex reference edge guide **4-67, 7-4**

E

E-clip identification **4-3**
 electrophotographic (EP) drive assembly
 fuser retract link **4-75**
 parts catalog **7-6**
 removal **4-70**
 service check **2-48, 2-50**
 Energy Conserve **3-35**
 Enforce Color Order **3-41**
 engine setting **3-24**
 Env Prompts **3-42**
 error codes and messages
 1xx service error codes **2-17–2-19**
 2xx paper jams **2-19–2-30**
 3x–8x attendance messages **2-9–2-16**
 9xx service error codes **2-33–2-39**
 ESD-sensitive parts **4-2**
 event log
 configuration menu **3-33**
 diagnostics mode **3-28**
 exit sensor
 service check **2-141**

F

Factory Defaults **3-35**
 fans
 cartridge cooling **4-53**
 cooling fan **4-65**
 service check **2-126**
 fasteners **4-3**
 fax modem
 parts catalog **7-25**
 removal **4-82**
 filter
 cooling fan filter **4-66**
 flatbed air filter **4-231**
 spare air filter **6-5**
 Flash Test **3-23**
 flatbed
 carriage transport belt **4-229**
 cleaning **6-2**
 flatbed (entire) **4-240**
 flatbed cave LED card and cover **4-199**
 flatbed CCD carrier module **4-235**
 flatbed CCD lamp assembly **4-232**
 flatbed cooling fan **4-239**
 flatbed with glass cover **4-201**
 lock **2-32, 4-120**
 parts catalog **7-18**
 scanner front cover **4-205**
 scanner left cover **4-206**
 scanner MDC card **4-247**
 scanner rear cover **4-207**
 scanner right cover **4-208**
 specifications **1-3**
 Font Sharpening **3-46**

front access cover assembly
 removals **4-20**
 front cover locks **3-49**
 front door assembly
 left front cable removal **4-86**
 parts catalog **7-4**
 removal **4-83**
 right front cable removal **4-90**
 fuser AC cable
 removal **4-95**
 fuser assembly
 motor test **3-12**
 parts catalog **7-4**
 removal **4-94**
 Reset Fuser Cnt **3-31**
 service check **2-42, 2-47**
 fuser DC cable
 removal **4-97**
 Fuser Motor Test **3-12**
 fuser retract link **4-75**

H

hard drive assembly
 parts catalog **7-25**
 removal **4-98**
 high-capacity input tray (HCIT)
 controller board assembly **4-256**
 drawer slide assembly **4-257**
 elevator motor with sensor **4-257**
 feed with bushing roller **4-255**
 front tray cover **4-251**
 left cover **4-254**
 media tray assembly **4-250**
 photointerrupter sensor with cable assembly **4-262**
 pick tires **4-259**
 rear cover **4-252**
 right cover **4-253**
 slide assembly with spring **4-260**
 top plate assembly **4-264**
 high-voltage power supply (HVPS)
 cable removal **4-102**
 parts catalog **7-10**
 removal **4-100**

I

input tray
 parts catalog **7-14**
 removal **4-204**

J

jams
 common messages (diagram) **3-57**
 paper jam messages **2-19**
 Jobs on Disk **3-43**

L

- lamp, flatbed CCD lamp assembly
 - removal **4-232**
- links, top access cover **4-159**
- lithium battery **xvii, 4-148**
- lock
 - flatbed lock **2-32, 4-120**
 - front cover locked **3-49**
 - front cover locks **3-49**
- low-voltage power supply (LVPS)
 - parts catalog **7-6**
 - removal **4-104**
- lubrication specifications **6-1**

M

- maintenance, scheduled **6-2**
- media
 - error jam locations **3-57**
 - input and output capacities **1-10**
 - input and output sizes and types **1-11**
 - paper path **5-1**
 - specifications **1-8**
- media guidelines **1-13**
- menus
 - configuration menu **3-30**
 - diagnostics menu **3-3**
 - user menus **2-4**
- Mirror Motor Test **3-22**
- Model Name **3-24**
- models **1-1**
- Motor Calibration **3-42**
- Motor Calibration Test **3-26**
- motor driver
 - cable removal **4-106**
 - card removal **4-107**
- multipurpose feeder (MPF)
 - gear and housing removal **4-108**
 - motor assembly removal **4-110**
 - motor cable removal **4-114**
 - motor parts catalog **7-6**

O

- operator panel
 - bezel **4-31**
 - buttons **4-32**
 - description **2-2**
 - identification **2-2**
 - indicator light **2-2**
 - parts catalog **7-2**
 - removal **4-26**
 - service check **2-145**
 - display all diamonds, 5 beeps **2-147**
 - display all diamonds, no beeps **2-146**
 - display blank, 5 beeps, LED off **2-146**
 - display blank, 5 beeps, LED on **2-146**
 - one or more buttons fail **2-145**
- option cable, removal **4-115**
- options and features
 - description **1-1**
 - parts catalog **7-24**

P

- Panel Menus **3-34**
- Panel Test **3-15**
- paper
 - See media
- paper jams, error locations **3-57**
- paper path
 - diagram **5-1**
- paper pick mechanism
 - parts catalog **7-4**
 - removal **4-117**
 - service check **2-46, 2-55**
- Paper Prompts **3-42**
- paper support (output bin extension cover) **4-36**
- paper tray
 - parts catalog **7-4**
- parts catalog
 - automatic document feeder (ADF) **7-16**
 - cable parts packet **7-13**
 - covers—printer **7-2**
 - covers—scanner **7-14**
 - flatbed scanner **7-18**
 - front **7-4**
 - left **7-10**
 - optional 550-sheet media drawer and tray **7-20**
 - optional high-capacity input option (HCIT) **7-22**
 - optional special media tray assembly **7-21**
 - rear **7-8**
 - right **7-6**
 - top **7-12**
- Perm Page Count **3-24**
- photoconductor unit **4-2**
 - handling **4-2**
 - installation **4-124**
 - parts not to be touched **4-2**
 - removal **4-124**
 - transportation/storage **4-2**
- Pick tires, replacement **4-125**
- power cords **7-9**
- power-on self test (POST)
 - service check **2-107, 2-108, 2-109, 2-110, 2-111, 2-112, 2-113, 2-115, 2-116, 2-117, 2-118, 2-119, 2-120, 2-122, 2-124**
- power-on self test (POST) sequence **2-5**
- PPDS Emulation **3-34**
- print quality
 - background **2-148**
 - blank page **2-149**
 - blurred or fuzzy print **2-150**
 - half-color page **2-150**
 - horizontal banding **2-150**
 - horizontal line **2-151**
 - insufficient fusing **2-151**
 - missing image at edge **2-151**
 - mottle (2–5mm speckles) **2-151**
 - narrow vertical line **2-151**
 - random marks **2-151**
 - residual image **2-152**

- solid color page [2-152](#)
 - vertical banding [2-153](#)
 - printer pads
 - parts catalog [7-4](#)
 - removal [4-126](#)
 - printhead
 - clean lenses [6-5](#)
 - parts catalog [7-8](#)
 - removal [4-128](#)
 - service check [2-40](#), [2-41](#)
 - verification [3-52](#)
 - printhead alignment [4-9](#)
 - printhead verification [3-52](#)
 - Prt Color Pg Count [3-24](#)
 - Prt Mono Pg Count [3-24](#)
 - Prt Quality Pgs
 - configuration menu [3-32](#)
 - diagnostic menu [3-14](#)
- Q**
- Quick Disk Test [3-22](#)
 - Quick Test (duplex) [3-18](#)
- R**
- removal and cleaning precautions [4-1](#)
 - removals
 - 24 V interlock switch [4-50](#)
 - 5 V interlock switch cable [4-48](#)
 - ADF (entire) [4-210](#)
 - ADF case assembly [4-213](#)
 - ADF closed cover flag [4-215](#)
 - ADF exit sensor [4-216](#)
 - ADF front cover [4-190](#)
 - ADF front side cover [4-192](#)
 - ADF handle cover [4-193](#)
 - ADF hinge [4-218](#)
 - ADF motor gear train [4-219](#)
 - ADF motor side cover [4-194](#)
 - ADF paper stop [4-223](#)
 - ADF pick pad [4-223](#)
 - ADF pick pad spring [4-224](#)
 - ADF pick roller assembly [4-224](#)
 - ADF pressure plate cover [4-226](#)
 - ADF separator pad [4-228](#)
 - ADF upper case cover [4-197](#)
 - bin full sensor assembly [4-52](#)
 - carriage transport belt with clip [4-229](#)
 - cartridge cooling fan [4-53](#)
 - cartridge motor 1/fuser cable [4-55](#)
 - cartridge motor 2/3 cable [4-57](#)
 - color on demand assembly [4-59](#)
 - contact springs [4-63](#)
 - cooling fan [4-65](#)
 - cooling fan filter [4-66](#)
 - covers, printer
 - front access cover assembly [4-20](#)
 - left cover [4-23](#)
 - left door cover [4-25](#)
 - operator panel assembly [4-26](#)
 - operator panel bezel [4-31](#)
 - operator panel buttons [4-32](#)
 - output bin extension cover [4-36](#)
 - rear cover [4-37](#)
 - rear frame cover [4-38](#)
 - right cover [4-39](#)
 - top access cover assembly [4-41](#)
 - top cover assembly [4-45](#)
 - covers, scanner and ADF
 - ADF front cover [4-190](#)
 - ADF front side cover [4-192](#)
 - ADF handle cover [4-193](#)
 - ADF motor side cover [4-194](#)
 - ADF upper case cover [4-197](#)
 - flatbed cave LED card cover [4-199](#)
 - flatbed with glass cover [4-201](#)
 - input tray [4-204](#)
 - scanner front cover [4-205](#)
 - scanner left cover [4-206](#)
 - scanner rear cover [4-207](#)
 - scanner right cover [4-208](#)
 - duplex reference edge guide [4-67](#)
 - electrophotographic (EP) process drive assembly [4-70](#)
 - ESD brush [4-230](#)
 - fax modem [4-82](#)
 - flatbed air filter [4-231](#)
 - flatbed cave LED card [4-199](#)
 - flatbed cave LED cover [4-199](#)
 - flatbed CCD carrier module [4-235](#)
 - flatbed cooling fan [4-239](#)
 - flatbed scanner [4-240](#)
 - flatbed with glass cover [4-201](#)
 - front door assembly [4-83](#)
 - front door assembly cable (left) [4-86](#)
 - front door assembly cable (right) [4-90](#)
 - fuser AC cable [4-95](#)
 - fuser assembly [4-94](#)
 - fuser DC cable [4-97](#)
 - hard drive assembly [4-98](#)
 - high-voltage power supply (HVPS) [4-100](#)
 - high-voltage power supply cable [4-102](#)
 - input tray [4-204](#)
 - left bellcrank [4-103](#)
 - low voltage power supply (LVPS) [4-104](#)
 - motor driver cable [4-106](#)
 - motor driver card [4-107](#)
 - multipurpose feeder (MPF)
 - motor cable [4-114](#)
 - multipurpose feeder/duplex gear and housing [4-108](#)
 - multipurpose feeder/duplex motor assembly [4-110](#)
 - operator panel bezel [4-31](#)
 - operator panel buttons [4-32](#)
 - option cable [4-115](#)
 - options
 - HCIT controller board assembly [4-256](#)
 - HCIT drawer slide assembly [4-257](#)
 - HCIT elevator motor with sensor [4-257](#)
 - HCIT feed with bushing roller [4-255](#)
 - HCIT front tray cover [4-251](#)
 - HCIT left cover [4-254](#)

- HCIT media tray assembly **4-250**
- HCIT photointerrupter sensor with cable assembly **4-262**
- HCIT pick tires **4-259**
- HCIT rear cover **4-252**
- HCIT right cover **4-253**
- HCIT slide assembly with spring **4-260**
- HCIT top plate assembly **4-264**
- paper pick mechanism assembly **4-117**
- paper present LED card **4-243**
- photoconductor unit **4-124**
- pick roll rubber tires **4-125**
- precautions **4-19**
- printer pad **4-126**
- printhead **4-128**
- right bellcrank **4-147**
- scanner front cover **4-205**
- scanner ICC cable **4-245**
- scanner ICC card **4-244**
- scanner left cover **4-206**
- scanner MDC card **4-247**
- scanner rear cover **4-207**
- scanner right cover **4-208**
- system board **4-148**
- system board support shield **4-154**
- toner level sensor **4-157**
- top access cover links **4-159**
- top access cover sensor **4-160**
- top cover camshaft assembly **4-162**
- transfer belt **4-168**
- transport cable **4-170**
- transport motor cable **4-173**
- UICC cable **4-178**
- UICC card **4-174**
- USB connector cable **4-182**
- waste toner assembly **4-186**
- wireless network antenna **4-187**
- wireless network card **4-188**
- Reset Calibration **3-26**
- Reset Fuser Cnt **3-31**
- S**
- safety information **xvii**
- safety inspection guide **6-1**
- scanner
 - cleaning **6-2**
 - diagnostics tests **3-9**
 - lock **2-32, 4-120**
- scanner specifications **1-3**
- screw and retainer identification table **4-3**
- sensors
 - ADF exit sensor **4-216**
 - bin full **4-52**
 - diagnostic tests **3-21**
 - exit sensor service check **2-141**
 - input sensor service check **2-143**
 - paper present LED card **4-243**
 - toner level **4-157, 7-10**
 - top access cover **4-160**
- separator pad
 - spare **6-5**
- serial number
 - viewing **3-24**
- service checks
 - 110.xx—Mirror motor **2-40**
 - 111.xx–114.xx—printhead error **2-41**
 - 120.xx—fuser error **2-42**
 - 140.xx—Autocomp motor error **2-46**
 - 142.xx,—motor error **2-47**
 - 142.xx—fuser motor error **2-47**
 - 143.xx—motor error **2-48**
 - 144.xx—motor error **2-50**
 - 145.xx, 906.05–906.08—motor error **2-55**
 - 146.xx—motor error **2-53**
 - 155.xx—motor error **2-56**
 - 156.xx—motor error **2-58, 2-60**
 - 906.01–906.04—motor error **2-47**
 - 920.03—POST error **2-106**
 - 920.04—POST error **2-107**
 - 920.05—POST error **2-108**
 - 920.07—POST error **2-109**
 - 920.09–920.12—POST error **2-110, 2-111, 2-112, 2-113**
 - 920.13—POST error **2-113**
 - 920.14—POST error **2-115**
 - 920.15—POST error **2-116**
 - 920.16—POST error **2-117**
 - 920.17—POST error **2-118**
 - 920.18—POST error **2-119**
 - 920.19—POST error **2-120**
 - 920.21—POST error **2-122**
 - 920.23—POST error **2-124**
 - 925.01, 925.03, 925.05—fan error **2-126**
 - 925.02, 925.04, 925.06—blower error **2-127**
 - 945.xx, 947.xx—Transfer roll error **2-128**
- dead printer **2-140**
- exit sensor **2-141**
- input sensor **2-143**
- networking **2-144**
- operator panel **2-145**
- print quality **2-147**
- service error codes **2-17**
- Servo Laser Test **3-22**
- Size Sensing **3-33**
- skew **3-6, 4-9**
- specifications
 - acoustic **1-7**
 - clearances **1-3**
 - data streams **1-4**
 - dimensions **1-2**
 - dimentions **1-2**
 - electrical and power **1-6**
 - environment **1-5**
 - mechanical specifications **1-3**
 - meda **1-8**
 - memory **1-4**
 - resolution **1-4**
- start **2-1**

- supplies, ADF supply space **6-5**
- symptoms
 - print quality **2-6**
 - printer **2-6**
- system board
 - parts catalog **7-8**
 - removal **4-148**
- system board support shield
 - parts catalog **7-8**
 - removal **4-154**

T

- test pages
 - print quality test pages **3-14, 3-32**
 - Quick Test **3-8**
 - quick test (duplex) **3-18**
- toner level sensor
 - parts catalog **7-10**
 - removal **4-157**
- Toner Patch Sensing (TPS) **3-40**
- tools required **1-15**
- top access cover
 - parts catalog **7-2**
 - removal **4-41**
 - sensor **4-160**
- top access cover links, removal **4-159**
- top cover
 - parts catalog **7-2**
 - removal **4-45**
- top cover camshaft assembly
 - parts catalog **7-12**
 - removal **4-162**
- transfer contact assembly, parts catalog **7-10**
- transfer module
 - parts catalog **7-4**
 - removal **4-168**
 - service check **2-128**
- Transfer Motor Test **3-12**
- transport cable, removal **4-170**
- transport motor cable, removal **4-173**

U

- UICC card
 - parts catalog **7-2**
 - removal **4-174**
- USB connector cable
 - removal **4-182**

V

- voltage switch, LVPS **4-105**

W

- waste toner assembly, removal **4-186**
- wireless network antenna
 - parts catalog **7-24**
 - removal **4-187**
- wireless network card
 - parts catalog **7-24**
 - removal **4-188**

Part number index

P/N	Description	Page
40X0047	Bar code and Forms card	7-25
40X0088	Card for IPDS and SCS/TNe	7-25
40X0269	Power cord—USA, Canada, Bolivia, Peru	7-9
40X0271	Power cord (8 ft.)—Hong Kong, Ireland, United Kingdom	7-9
40X0273	Power cord (8 ft.)—Chile, Uruguay	7-9
40X0275	Power cord (8 ft.)—Israel	7-9
40X0288	Power cord (8 ft.)—Argentina	7-9
40X0301	Power cord (8 ft.)—Australia, New Zealand	7-9
40X0303	Power cord (8 ft.)—China	7-9
40X1416	Toner level sensor	7-11
40X1446	Right bellcrank assembly, with spring	7-5
40X1447	Left bellcrank assembly, with spring	7-5
40X1772	Power cord (8 ft.)—Switzerland	7-9
40X1773	Power cord (8 ft.)—South Africa	7-9
40X1774	Power cord (8 ft.)—Denmark, Finland, Norway, Sweden	7-9
40X1791	Power cord (8 ft.)—Taiwan	7-9
40X1792	Power cord (8 ft.)—Korea	7-9
40X3141	Power cord (8 ft.)—Austria, Belgium, Catalan, Czechoslovakia, Finland, France, Germany, Greece, Hungary, Ireland, Italy, Netherlands, Norway, Paraguay, Poland, Portugal, Russia, Spain, Sweden, Turkey, United Kingdom	7-9
40X3609	Power cord (8 ft.)—Japan	7-9
40X4585	Tray latch with spring	7-23
40X4587	Slide assembly with springs	7-23
40X4593	HCIT drawer slide assembly	7-23
40X4596	Power cord (8 ft.)—Brazil	7-9
40X4597	Card reader cable	7-25
40X4598	Smart card cover	7-25
40X4602	3121 Card reader card	7-25
40X4603	5121 Card reader card	7-25
40X4604	5125 card reader card	7-25
40X4819	Serial interface card adapter	7-25
40X4821	Fax modem card	7-25
40X4822	80.0 GB hard disk assembly	7-25
40X4823	Parallel 1284-B interface card adapter	7-25
40X4826	MarkNet N8120 10/1000	7-25
40X4827	MarkNet N8130 10/100 fiber	7-25
40X5038	Wireless network card (802.11g), US/Americas	7-25
40X5039	Wireless network card (802.11g), rest of the world	7-25
40X5093	Fuser assembly, 115 V	7-5
40X5094	Fuser assembly, 230 V	7-5
40X5095	Fuser assembly, 100 V	7-5
40X5096	Transfer belt assembly	7-5
40X5107	System board support shield	7-9
40X5108	Cartridge cooling fan	7-12
40X5109	Cooling fan	7-12
40X5111	Parts packet, front door	7-5
40X5112	Front access door cover assembly	7-3
40X5113	Duplex reference edge assembly	7-5
40X5121	Top access cover sensor	7-3
40X5122	Color on demand assembly	7-12
40X5123	Printhead assembly	7-9
40X5125	EP drive assembly	7-7
40X5126	Motor driver card	7-7
40X5127	5 V interlock switch	7-7

40X5128	24 V interlock switch	7-7
40X5129	High-voltage power supply	7-11
40X5130	Top cover camshaft assembly	7-12
40X5131	MP feeder/duplex motor	7-7
40X5132	Parts packet, MP feeder/duplex drive	7-5
40X5136	Parts packet, screws	7-5, 7-25
40X5137	Contact springs kit	7-11
40X5140	550-sheet tray option (drawer and tray assembly)	7-20
40X5141	550-sheet tray assembly	7-20
40X5142	Special media assembly, including tray	7-21
40X5143	Special media tray assembly	7-21
40X5144	HCIT tray assembly	7-23
40X5146	HCIT front tray cover	7-23
40X5147	HCIT right cover	7-23
40X5148	HCIT left cover	7-23
40X5149	HCIT rear cover	7-23
40X5152	Pick tire (550-sheet drawer)	7-21
40X5155	Elevator motor with sensor	7-23
40X5156	Feed with bushing	7-23
40X5157	Top plate assembly	7-23
40X5158	Photointerrupter sensor with cable assembly	7-23
40X5159	HCIT controller card assembly	7-23
40X5163	Separator pad spring	7-17
40X5164	Output bin extension cover	7-3
40X5165	ADF static ground brush	7-17
40X5166	ADF exit sensor with cable	7-17
40X5167	Flatbed scanner, complete	7-19
40X5168	Pick tire	7-5, 7-20, 7-23
40X5169	Rear frame cover	7-3
40X5172	Right cover	7-3
40X5173	Left cover	7-3
40X5174	Rear cover	7-3
40X5175	Top cover assembly	7-3
40X5176	Top access cover assembly	7-3
40X5177	Operator panel bezel, 235, 275	7-3
40X5178	Operator panel bezel, 436, 476	7-3
40X5179	Operator panel assembly, with card	7-3
40X5180	Top access cover parts package	7-3
40X5181	Parts packet (operator panel buttons)	7-3
40X5182	Low-voltage power supply	7-7
40X5183	Parts packet (cables)	7-13
40X5184	Front accessdoor assembly	7-5
40X5185	Parts packet, scanner screws	7-25
40X5186	UICC card	7-3
40X5187	ADF separator pad	7-17
40X5188	ADF pick roll assembly	7-17
40X5189	ADF pick pad	7-17
40X5190	ADF, complete	7-17
40X5191	ADF cover open flag	7-17
40X5192	ADF document input tray	7-15
40X5193	ADF paper stop	7-15
40X5194	Pressure plate cover	7-15
40X5195	ADF front case assembly	7-17
40X5196	ADF front case cover	7-15
40X5197	ADF upper case cover	7-17
40X5198	Filter door cover	7-15
40X5199	Flatbed cooling fan	7-19
40X5200	System board (network), 235, 275, 295	7-9
40X5201	ADF lid handle cover	7-15

40X5202	ADF upper motor side cover	7-15
40X5203	ADF upper front side cover	7-15
40X5204	Scanner left cover	7-15
40X5205	Scanner right cover	7-15
40X5206	Scanner front cover	7-15
40X5207	Scanner rear cover	7-15
40X5208	ADF motor gear train assembly	7-17
40X5209	ADF hinge (left or right)	7-17
40X5210	Paper present LED card	7-17
40X5211	Flatbed with glass cover	7-15
40X5212	Flatbed CCD carrier module	7-19
40X5213	Flatbed CCD lamp assembly	7-19
40X5214	Carriage transport belt with clip	7-19
40X5215	Cave LED card	7-19
40X5216	Flatbed cave LED cover (clear)	7-19
40X5217	Parts packet, Scanner cable parts	7-19
40X5218	Flatbed air filter	7-15
40X5219	Scanner MDC card	7-19
40X5220	Scanner ICC card	7-17
40X5221	Left door cover	7-3
40X5222	Operator panel bezel, 636, 676	7-3
40X5271	System board (network), 436, 476, 496, 636, 676	7-9
40X5273	Paper tray assembly, 550-sheet	7-5
40X5275	Paper pick assembly	7-5
40X5281	High-capacity input tray (HCIT) relocation kit	7-25
40X5285	Printer relocation kit	7-25
40X5287	Cooling fan filter	7-3
40X5288	Operator panel bezel, 496	7-3
40X5289	Operator panel bezel, 295	7-3
40X5301	256 MB SDRAM, 100-pin	7-25
40X5302	512 MB SDRAM, 100-pin	7-25
40X5303	1024 MB SDRAM, 100-pin	7-25
40X5315	ISP thumbscrew	7-25
40X5316	14-pin JST cable assembly for ISP interface cable	7-25
40X5317	Parts packet, ISP thumbscrew and standoff	7-25
40X5318	Wireless ISP thumbscrew	7-25
40X5319	Wireless antenna (802.11)	7-25
40X5606	14-pin JST cable assembly for fax modem card	7-25
40X5704	256 MB flash card	7-25
40X5952	Lexmark PrintCryption card	7-25
40X5969	Korean font card	7-25
40X5970	Simplified Chinese font card	7-25
40X5971	Traditional Chinese font card	7-25
40X5972	Japanese font card	7-25
7377200	Option drawer relocation kit	7-25

