



# Color Laser Printer

## CLP-775ND series

# **SERVICE** MANUAL

Color Laser Printer

Contents



1. Precautions
2. Product spec and feature
3. Disassembly and Reassembly
4. Alignment and Troubleshooting
5. System Diagram
6. Reference Information

Refer to the service manual in the GSPN (see the rear cover) for more information.

# Contents

---

- 1. Precautions ..... 1 – 1
  - 1.1. Safety warning ..... 1 – 1
  - 1.2. Caution for safety ..... 1 – 2
    - 1.2.1. Toxic material ..... 1 – 2
    - 1.2.2. Electric shock and fire safety precautions ..... 1 – 2
    - 1.2.3. Handling precautions ..... 1 – 3
    - 1.2.4. Assembly and Disassembly precautions ..... 1 – 3
    - 1.2.5. Disregarding this warning may cause bodily injury ..... 1 – 4
  - 1.3. ESD precautions ..... 1 – 5
- 2. Product spec and feature ..... 2 – 1
  - 2.1. Product Specifications ..... 2 – 1
    - 2.1.1. Product Overview ..... 2 – 1
    - 2.1.2. Specifications ..... 2 – 2
      - 2.1.2.1. General Print Engine ..... 2 – 2
      - 2.1.2.2. Controller and Software ..... 2 – 2
      - 2.1.2.3. Paper Handling ..... 2 – 3
      - 2.1.2.4. Reliability & Service ..... 2 – 4
      - 2.1.2.5. Consumables ..... 2 – 4
      - 2.1.2.6. Maintenance part ..... 2 – 5
      - 2.1.2.7. Environment ..... 2 – 6
      - 2.1.2.8. Packing & Accessory ..... 2 – 6
      - 2.1.2.9. Options ..... 2 – 6
    - 2.1.3. Model Comparison Table ..... 2 – 7
  - 2.2. System Overview ..... 2 – 8
    - 2.2.1. Front View ..... 2 – 8
    - 2.2.2. Rear View ..... 2 – 9
    - 2.2.3. Paper Path ..... 2 – 10
    - 2.2.4. System Layout ..... 2 – 11
      - 2.2.4.1. Feeding Section ..... 2 – 12
      - 2.2.4.2. Fuser Unit ..... 2 – 13
      - 2.2.4.3. Drive Unit ..... 2 – 14
      - 2.2.4.4. LSU (Laser Scanner Unit) ..... 2 – 15
      - 2.2.4.5. PTB (Paper Transfer Belt) Unit ..... 2 – 16
      - 2.2.4.6. Toner Cartridge ..... 2 – 17
    - 2.2.5. Hardware Configuration ..... 2 – 18
      - 2.2.5.1. Main PBA ..... 2 – 19
      - 2.2.5.2. SMPS board ..... 2 – 21
      - 2.2.5.3. HVPS Board ..... 2 – 23

2.2.5.4.	HVPS sub board .....	2 – 25
2.2.5.5.	Fuser Drive Board .....	2 – 26
2.2.5.6.	OPE Board.....	2 – 27
2.2.5.7.	Sensor.....	2 – 28
2.2.6.	Software Descriptions .....	2 – 30
2.2.6.1.	Overview.....	2 – 30
2.2.6.2.	Architecture .....	2 – 30
2.2.6.3.	Data and Control Flow .....	2 – 31
3.	Disassembly and Reassembly .....	3 – 1
3.1.	Precautions when replacing parts .....	3 – 1
3.1.1.	Precautions when assembling and disassembling .....	3 – 1
3.1.2.	Precautions when handling PBA .....	3 – 1
3.1.3.	Releasing Plastic Latches .....	3 – 2
3.2.	Screws used in the printer.....	3 – 3
3.3.	Replacing a maintenance parts.....	3 – 6
3.3.1.	Fuser Unit.....	3 – 6
3.3.2.	Pick-Up roller .....	3 – 7
3.3.3.	Retard Roller .....	3 – 8
3.3.4.	Dust Cleaning Kit.....	3 – 9
3.4.	Disassembly Procedure .....	3 – 10
3.4.1.	Cover.....	3 – 10
3.4.2.	Front Cover.....	3 – 13
3.4.3.	OPE Unit .....	3 – 14
3.4.4.	Main PBA.....	3 – 14
3.4.5.	HVPS board .....	3 – 15
3.4.6.	SMPS Board.....	3 – 15
3.4.7.	HVPS Sub Board (AC Board).....	3 – 16
3.4.8.	Fuser Control Board.....	3 – 17
3.4.9.	LSU.....	3 – 18
3.4.10.	Clutch Pick-Up and Clutch-Feed .....	3 – 19
4.	Alignment and Troubleshooting .....	4 – 1
4.1.	Alignment and Adjustments.....	4 – 1
4.1.1.	Control Panel.....	4 – 1
4.1.2.	Understanding The Status LED .....	4 – 2
4.1.3.	JAM Removal.....	4 – 3
4.1.3.1.	Clearing Paper Jams .....	4 – 3
4.1.4.	Useful menu item for service .....	4 – 7
4.1.5.	Periodic Defective Image .....	4 – 8
4.1.6.	Useful management tools.....	4 – 9
4.1.6.1.	Using Samsung Easy Printer Manager (Windows only) .....	4 – 9

- 4.1.6.2. Using Samsung Printer Status (Windows only) ..... 4 – 10
- 4.1.6.3. Using Smart Panel (Macintosh and Linux only) ..... 4 – 12
- 4.1.7. Updating Firmware ..... 4 – 14
  - 4.1.7.1. Update the firmware by using the USB port ..... 4 – 14
  - 4.1.7.2. Update the firmware by using the network ..... 4 – 15
- 4.1.8. Tech Mode ..... 4 – 17
  - 4.1.8.1. To enter the Tech Mode ..... 4 – 17
  - 4.1.8.2. Tech Mode Menu Map ..... 4 – 18
  - 4.1.8.3. Tech Mode Menu description ..... 4 – 19
- 4.2. Troubleshooting ..... 4 – 24
  - 4.2.1. Procedure of Checking the Symptoms ..... 4 – 24
    - 4.2.1.1. Basic Check List ..... 4 – 25
  - 4.2.2. Error code and troubleshooting ..... 4 – 26
  - 4.2.3. Image quality problems ..... 4 – 60
  - 4.2.4. Other errors ..... 4 – 64
- 5. System Diagram ..... 5 – 1
  - 5.1. Block Diagram ..... 5 – 1
  - 5.2. Connection Diagram ..... 5 – 2
- 6. Reference Information ..... 6 – 1
  - 6.1. Tool for Troubleshooting ..... 6 – 1
  - 6.2. Acronyms and Abbreviations ..... 6 – 2
    - 6.2.1. Acronyms ..... 6 – 2
    - 6.2.2. Service Parts ..... 6 – 4
  - 6.3. The Sample Pattern for the Test ..... 6 – 7
    - 6.3.1. A4 ISO 19798 Standard Pattern ..... 6 – 7
  - 6.4. Selecting a location ..... 6 – 8

# 1. Precautions

In order to prevent accidents and damages to the equipment please read the precautions listed below carefully before servicing the product and follow them closely.

## 1.1. Safety warning

- 1) Only to be serviced by a factory trained service technician.

High voltages and lasers inside this product are dangerous. This product should only be serviced by a factory trained service technician.

- 2) Use only Samsung replacement parts.

There are no user serviceable parts inside the product. Do not make any unauthorized changes or additions to the product as these could cause the product to malfunction and create an electric shocks or fire hazards.

- 3) Laser Safety Statement

The printer is certified in the U.S. to conform to the requirements of DHHS 21 CFR, chapter 1 Subchapter J for Class I(1) laser products, and elsewhere is certified as a Class I laser product conforming to the requirements of IEC/EN 60825-1:2014. Class I laser products are not considered to be hazardous. The laser system and printer are designed so there is never any human access to laser radiation above a Class I level during normal operation, user maintenance or prescribed service condition.

- Wavelength: 800 nm
- Beam divergence
  - Parallel: 11 degrees
  - Perpendicular: 35 degrees
- Maximum power of energy output: 12 mW



### WARNING

**Never operate or service the product with the protective cover removed from Laser/Scanner assembly. The reflected beam, although invisible, can damage your eyes.**

**When using this product, these basic safety precautions should always be followed to reduce risk of fire, electric shock, and personal injury.**



- 4) Lithium battery not replaceable by user

## 1.2. Caution for safety

---

### 1.2.1. Toxic material

---

This product contains toxic materials that could cause illness if ingested.

- 1) Please keep imaging unit and toner cartridge away from children. The toner powder contained in the imaging unit and toner cartridge may be harmful, and if swallowed, you should contact a doctor.

### 1.2.2. Electric shock and fire safety precautions

---

Failure to follow the following instructions could cause electric shock or potentially cause a fire.

- 1) Use only the correct voltage, failure to do so could damage the product and potentially cause a fire or electric shock.
- 2) Use only the power cable supplied with the product. Use of an incorrectly specified cable could cause the cable to overheat and potentially cause a fire.
- 3) Do not overload the power socket, this could lead to overheating of the cables inside the wall and could lead to a fire.
- 4) Do not allow water or other liquids to spill into the product, this can cause electric shock. Do not allow paper clips, pins or other foreign objects to fall into the product, these could cause a short circuit leading to an electric shock or fire hazard.
- 5) Never touch the plugs on either end of the power cable with wet hands, this can cause electric shock. When servicing the product, remove the power plug from the wall socket.
- 6) Use caution when inserting or removing the power connector. When removing the power connector, grip it firmly and pull. The power connector must be inserted completely, otherwise a poor contact could cause overheating possibly leading to a fire.
- 7) Take care of the power cable. Do not allow it to become twisted, bent sharply around corners or wise damaged. Do not place objects on top of the power cable. If the power cable is damaged it could overheat and cause a fire. Exposed cables could cause an electric shock. Replace the damaged power cable immediately, do not reuse or repair the damaged cable. Some chemicals can attack the coating on the power cable, weakening the cover or exposing cables causing fire and shock risks.
- 8) Ensure that the power sockets and plugs are not cracked or broken in any way. Any such defects should be repaired immediately. Take care not to cut or damage the power cable or plugs when moving the machine.
- 9) Use caution during thunder or lightning storms. Samsung recommends that this machine be disconnected from the power source when such weather conditions are expected. Do not touch the machine or the power cord if it is still connected to the wall socket in these weather conditions.
- 10) Avoid damp or dusty areas, install the product in a clean well ventilated location. Do not position the machine near a humidifier or in front of an air conditioner. Moisture and dust built up inside the machine can lead to overheating and cause a fire or cause parts to rust.
- 11) Do not position the product in direct sunlight. This will cause the temperature inside the product to rise possibly leading to the product failing to work properly and in extreme conditions could lead to a fire.
- 12) Do not insert any metal objects into the machine through the ventilator fan or other part of the casing, it could make contact with a high voltage conductor inside the machine and cause an electric shock.

---

### 1.2.3. Handling precautions

---

The following instructions are for your own personal safety to avoid injury and so as not to damage the product.

- 1) Ensure the product is installed on a level surface, capable of supporting its weight. Failure to do so could cause the product to tip or fall.
- 2) The product contains many rollers, gears and fans. Take great care to ensure that you do not catch your fingers, hair or clothing in any of these rotating devices.
- 3) Do not place any small metal objects, containers of water, chemicals or other liquids close to the product which if spilled could get into the machine and cause damage or a shock or fire hazard.
- 4) Do not install the machine in areas with high dust or moisture levels, beside an open window or close to a humidifier or heater. Damage could be caused to the product in such areas.
- 5) Do not place candles, burning cigarettes, etc on the product, These could cause a fire.
- 6) Ensure that the machine is installed and used in proper area to meet the temperature and humidity specifications.
  - If the machine is stored at below zero Celsius for a long time, do not use the machine instantly after movement. It can malfunction. Take care of the machine storage. If the machine is stored at below zero Celsius for a long time, keep the machine at room temperature and install it.

---

### 1.2.4. Assembly and Disassembly precautions

---

Replace parts carefully and always use Samsung parts. Take care to note the exact location of parts and also cable routing before dismantling any part of the machine. Ensure all parts and cables are replaced correctly. Please carry out the following procedures before dismantling the product or replacing any parts.

- 1) Check the contents of the machine memory and make a note of any user settings. These will be erased if the main board or network card is replaced.
- 2) Ensure that power is disconnected before servicing or replacing any electrical parts.
- 3) Disconnect interface cables and power cables.
- 4) Only use approved spare parts. Ensure that part number, product name, any voltage, current or temperature rating are correct.
- 5) When removing or re-fitting any parts do not use excessive force, especially when fitting screws into plastic.
- 6) Take care not to drop any small parts into the machine.
- 7) Handling of the OPC Drum
  - The OPC Drum can be irreparably damaged if it is exposed to light. Take care not to expose the OPC Drum either to direct sunlight or to fluorescent or incandescent room lighting. Exposure for as little as 5 minutes can damage the surface of the photoconductive properties and will result in print quality degradation. Take extra care when servicing the product. Remove the OPC Drum and store it in a black bag or other lightproof container. Take care when working with the Covers (especially the top cover) open as light is admitted to the OPC area and can damage the OPC Drum.
  - Take care not to scratch the green surface of the OPC Drum Unit. If the green surface of the Drum Cartridge is scratched or touched the print quality will be compromised.

### **1.2.5. Disregarding this warning may cause bodily injury**

---

- 1) Be careful with the high temperature part.

The fuser unit works at a high temperature. Use caution when working on the printer. Wait for the fuser to cool down before disassembly.

- 2) Do not put finger or hair into the rotating parts.

When operating a printer, do not put hand or hair into the rotating parts (Paper feeding entrance, motor, fan, etc.). If do, you can get harm.

- 3) When you move the printer.

This printer weighs 6kg including toner cartridge and cassette. Use safe lifting and handling techniques. Use the lifting handles located on each side of the machine. Back injury could be caused if you do not lift carefully.

- 4) Ensure the printer is installed safely.

The printer weighs 6kg, ensure the printer is installed on a level surface, capable of supporting its weight. Failure to do so could cause the printer to tip or fall possibly causing personal injury or damaging the printer.

- 5) Do not install the printer on a sloping or unstable surface. After installation, double check that the printer is stable.



## 1.3. ESD precautions

Certain semiconductor devices can be easily damaged by static electricity. Such components are commonly called “Electrostatically Sensitive (ES) Devices” or ESDs. Examples of typical ESDs are: integrated circuits, some field effect transistors, and semiconductor “chip” components. The techniques outlined below should be followed to help reduce the incidence of component damage caused by static electricity.



### CAUTION

**Be sure no power is applied to the chassis or circuit, and observe all other safety precautions.**

- 1) Immediately before handling a semiconductor component or semiconductor-equipped assembly, drain off any electrostatic charge on your body by touching a known earth ground. Alternatively, employ a commercially available wrist strap device, which should be removed for your personal safety reasons prior to applying power to the unit under test.
- 2) After removing an electrical assembly equipped with ESDs, place the assembly on a conductive surface, such as aluminum or copper foil, or conductive foam, to prevent electrostatic charge buildup in the vicinity of the assembly.
- 3) Use only a grounded tip soldering iron to solder or desolder ESDs.
- 4) Use only an “anti-static” solder removal device. Some solder removal devices not classified as “anti-static” can generate electrical charges sufficient to damage ESDs.
- 5) Do not use Freon-propelled chemicals. When sprayed, these can generate electrical charges sufficient to damage ESDs.
- 6) Do not remove a replacement ESD from its protective packaging until immediately before installing it. Most replacement ESDs are packaged with all leads shorted together by conductive foam, aluminum foil, or a comparable conductive material.
- 7) Immediately before removing the protective shorting material from the leads of a replacement ESD, touch the protective material to the chassis or circuit assembly into which the device will be installed.
- 8) Maintain continuous electrical contact between the ESD and the assembly into which it will be installed, until completely plugged or soldered into the circuit.
- 9) Minimize bodily motions when handling unpackaged replacement ESDs. Normal motions, such as the brushing together of clothing fabric and lifting one’s foot from a carpeted floor, can generate static electricity sufficient to damage an ESD.

## 2. Product spec and feature

---

### 2.1. Product Specifications

---

#### 2.1.1. Product Overview

---



- 1) Speed
  - 33 (Color) / 33 (Black) ppm in A4 (35 / 35 ppm in Letter)
- 2) Processor
  - 600 MHz
- 3) Printer Language
  - PS3, PCL5c, PCL6, PDF 1.4
- 4) Memory
  - 384 MB (Standard) / 896 MB (Max)
- 5) Interface
  - High Speed USB 2.0
  - 10/100/1000 BaseTX network connector
  - 802.11b/g/n wireless LAN (Optional)
  - IEEE 1284 Parallel (Optional)
  - HDD 250 GB (Optional)
- 6) Toner cartridge
  - Initial : 3.5K (K)/ 3.5K (CMY)
  - Sales: 7K (K)/ 7K (CMY)
- 7) Paper Handling
  - Maximum 1,600 Sheets Paper Capacity (500sh cassette, 500sh SCF x 2 EA, 100 MP)

## 2.1.2. Specifications

- Product Specifications are subject to change without notice. See below for product specifications.

### 2.1.2.1. General Print Engine

Items		Specification
Engine Speed	Simplex	<ul style="list-style-type: none"> <li>B&amp;W : Up to 33 ppm in A4 (35 ppm in Letter)</li> <li>Color : Up to 33 ppm in A4 (35 ppm in Letter)</li> </ul>
	Duplex	<ul style="list-style-type: none"> <li>B&amp;W : Up to 14 ppm in A4 (14 ppm in Letter)</li> <li>Color : Up to 14 ppm in A4 (14 ppm in Letter)</li> </ul>
Warm-up time	From Sleep	≤ 25 sec
FPOT (B&W)	From Ready	≤ 10 sec
	From Sleep	≤ 28 sec
FPOT (Color)	From Ready	≤ 11 sec
	From Sleep	≤ 30 sec
Resolution	Optical	600 x 600 dpi
	Support	<ul style="list-style-type: none"> <li>PCL <ul style="list-style-type: none"> <li>Best : 9,600 x 600 effective output</li> <li>Normal : 2,400 x 600 dpi</li> <li>Draft : 600 x 600 dpi</li> </ul> </li> <li>PostScript 3 <ul style="list-style-type: none"> <li>Best : 9,600 x 600 effective output</li> <li>Normal : 1,200 x 600 dpi</li> <li>Draft : 600x600 dpi</li> </ul> </li> </ul>

### 2.1.2.2. Controller and Software

Items		Specification
Processor		600 MHz
Memory	Std.	384 MB
	Max	896 MB
Printer Languages		PS3, PCL5 ,PLC6
Fonts		93 scalable ,1 bitmap PCL ,136 PS

## 2. Product spec and feature

Items		Specification
Driver	Default Driver	PCL6
	Supporting OS	Windows 2000/XP(32/64bits)/Vista(32/64bits)/2003 Server(32/64bits)/2008 Server(32/64bits) / Win7 /2008 R2
		<ul style="list-style-type: none"> <li>• Various Linux OS               <ul style="list-style-type: none"> <li>• Red Hat 8~9,</li> <li>• Fedora Core 1~4</li> <li>• Mandrake 9.2~10.1</li> <li>• SuSE 8.2~9.2</li> </ul> </li> <li>• Mac OS 10.3~10.6</li> </ul>
WHQL	Windows 2000/XP(32/64bits)/Vista(32/64bits)/2003 Server(32/64bits)/2008 Server(32/64bits) / Win7 /2008 R2	
Application	Management Tool	Easy Print Management
	Network Management	Set IP, SyncThru Web Admin Service 4.0
Interface	IEEE 1284 Parallel	Optional
	USB	Hi-Speed USB 2.0
	Wired Network	Ethernet 10/100/1000 Base TX
	Wireless Network	Optional
User Interface	LCD	4-Line LCD
	LED	1 Status LED

### 2.1.2.3. Paper Handling

Items		Specification
Standard Capacity		500-sheet Tray @ 80g/m <sup>2</sup> , 100-sheet MP Tray
Max. Capacity		1600 sheets @ 80g/m <sup>2</sup> (500-sheet basic Tray, 500-sheet SCF Tray x 2, 100-sheet MP)
Printing	Max. Size	216 x 356 mm (8.5" x 14")
	Min. Size	76 x 127 mm (3.0" x 5")
Standard Cassette Tray	Capacity	500 sheets @ 80g/m <sup>2</sup>
	Media sizes	76 x 127 mm (3" x 5") ~ 216 x 356mm (8.5" x 14")
	Media types	Plain paper
	Media weight	16~43lb (60 ~163 g/m <sup>2</sup> )
	Sensing	Paper Empty
MP Tray	Capacity	100-sheet @ 80g/m <sup>2</sup>
	Media sizes	A4 148.5 x 210 ~ Legal 216 x 356 (8.5"x14")
	Media types	Printer Default, Plain Paper, Thick, Thin, Cotton, Archive Paper, Bond, Card Stock, Labels, Preprinted, Color Paper, Envelope, Recycled
	Media weight	16~58lb (60 to 220g/m <sup>2</sup> )
	Sensing	Paper Empty

Items		Specification
Optional Cassette Tray	Capacity	500 sheets @ 80g/m <sup>2</sup>
	Media sizes	A5 148.5 x210mm ~ Legal 216 x 356mm (8.5" x 14")
	Media types	Plain paper
	Media weight	16~43lb (60 ~ 163 g/m <sup>2</sup> )
	Sensing	Paper Empty
Output Stacking	Face-Down	250 sheets @ 80g/m <sup>2</sup> (Base Line Paper : Samsung Premium/ Xerox4200) NN Condition
Duplex	Supporting	Standard
	Media sizes	A4, Letter, Legal, Oficio, Folio
	Media types	Plain paper only
	Media weight	16~32lb (60 ~120g/m <sup>2</sup> )

#### 2.1.2.4. Reliability & Service

Items	Specification
Printing Volume (SET AMPV)	1800 Pages , 1080/720 pages (Color and mono prints)
Max Monthly Duty	120,000 pages
MPBF	65,000 pages
MTTR	< 30 min.

#### 2.1.2.5. Consumables

Items		Specification
Toner Cartridge	Model	CLT-C609S (Cyan) CLT-M609S (Magenta) CLT-Y609S (Yellow) CLT-K609S (Black)
	Yield	<ul style="list-style-type: none"> <li>Initial (CMYK): Average Cartridge Yield 3.5K standard pages.</li> <li>Sales (CMYK): Average cartridge Yield 7K standard pages</li> </ul> Declared cartridge yield in accordance with ISO/IEC 19798.
Paper Transfer Belt (PTB)	Model	CLT-T508
	Yield	50K pages

## 2.1.2.6. Maintenance part

	Items	Part Code (Part Name)	Life	UI Warning Message F: First, A: After "OK" Button
Main Set	Fuser Unit	JC96-05454B (Fuser,110V) JC96-05455B (Fuser,220V)	100K Pages	[Low Status] F: Prepare Fuser unit A: Prepare new fuser unit [Empty Status] F: Replace Fuser unit A: Replace with new fuser unit
	Pickup-Roller (Tray1)	JC73-00340A (RUBBER-PICK UP)	100K Pages	N/A
	Retard Roller (Tray1)	JC90-01063A (CASSETTE-RETARD)	100K Pages	F: Replace Retard roller A: Replace with new Tray1 Retard roller
	Pickup-Roller (MPT)	JC66-03043A (ROLLER-RUBBER P/UP MP)	100K Pages	N/A
	Friction Pad (MPT)	JC73-00132A (RPR-FRICTION PAD MP)	100K Pages	N/A
	Dust cleaning Kit	JC93-00399A (FRAME-REGI- CLEANING)	100K Pages	F: Replace Dust Cleaning A: Replace with new Dust Cleaning kit
SCF1	Pickup-Roller (Tray2)	JC97-02259A	200K Pages	N/A
	Forward Roller (Tray2)	(MEA UNIT-ROLLER PU)		N/A
	Retard Roller (Tray2)	JC97-02259A (MEA UNIT-ROLLER PU)	100K Pages	F: Replace Retard roller A: Replace with new Tray2 Retard roller
SCF2	Pickup-Roller (Tray3)	JC97-02259A	200K Pages	N/A
	Forward Roller (Tray3)	(MEA UNIT-ROLLER PU)		N/A
	Retard Roller (Tray3)	JC97-02259A (MEA UNIT-ROLLER PU)	100K Pages	F: Replace Retard roller A: Replace with new Tray3 Retard roller

**2.1.2.7. Environment**

Items		Specification
Operating Environment	Temperature	15 °C ~ 32.5 °C
	Humidity	10% ~ 80%
Acoustic Noise Level (Sound Power/ Pressure)	Printing	Less than 54 dBA
	Standby	Less than 35 dBA
	Sleep	Back Ground Level
Input Voltage		110-127 VAC, 50/60Hz or 220-240 VAC, 50/60Hz
Power Consumption	Ready	Less than 60 Wh
	AVG.	Less than 750 Wh
	Max/Peak	Less than 1000 Wh
	Sleep	Less than 8 Wh
Dimension (W x D x H)	SET	446 x 481 x 464 mm (17.6 x 18.9 x 18.3 inches) without optional tray
Weight	SET with consumables	30.4 kg (67 lbs)



**2.1.2.8. Packing & Accessory**

Item	Accessory
In-Box	Driver Install CD-ROM Power Cable USB Cable (CIS/China/Korea/India) Quick Install Guide Warranty Registration Card User's Manual (HTML) Initial Toner Cartridge (CMYK)

**2.1.2.9. Options**

Items	Model Name	Remark
Memory	ML-MEM170	512MB
Second Cassette Feeder	CLP-S775	500-sheet Cassette
Wireless Network	ML-NWA65L	
Hard Disk	ML-HDK 425	250 GB
IEEE 1284B Parallel	ML-PAR100	

### 2.1.3. Model Comparison Table

	Samsung CLP-775ND	Samsung CLP-770ND	HP P1505n
Image			
Mono/Color Speed (A4)	33 ppm / 33 ppm	32 ppm / 32 ppm	30 ppm / 30 ppm
Processor	600 MHz Dual Core	800 MHz	516 MHz
Memory (Std/ Max)	384 MB / 896 MB	256 MB / 768 MB	256~512 MB / 1024 MB
Print Language	PCL5/6, PS3, PDF 1.4	PCL5/6, PS3, PDF 1.4	PCL5/6, PS3, PDF 1.4
Paper Input	500 Cassette, 100 MP 500 x 2 SCF	500 Cassette, 100 MP 500 x 2 SCF	250 Cassette, 100 MP 500 SCF
Duplex	Std	Std	Std
Interface	High Speed USB 2.0 Gigabit Ethernet USB Host	High Speed USB 2.0 Gigabit Ethernet USB Host	High Speed USB 2.0 Gigabit Ethernet USB Host
Size (mm)	446 x 481 x 464 mm	446 x 481 x 464 mm	513 x 490 x 358 mm
Toner Cartridge (Mono/Color)	7K / 7K	7K / 7K	10.5K / 7K



## 2.2. System Overview

This chapter describes the functions and operating principals of the printer.

### 2.2.1. Front View

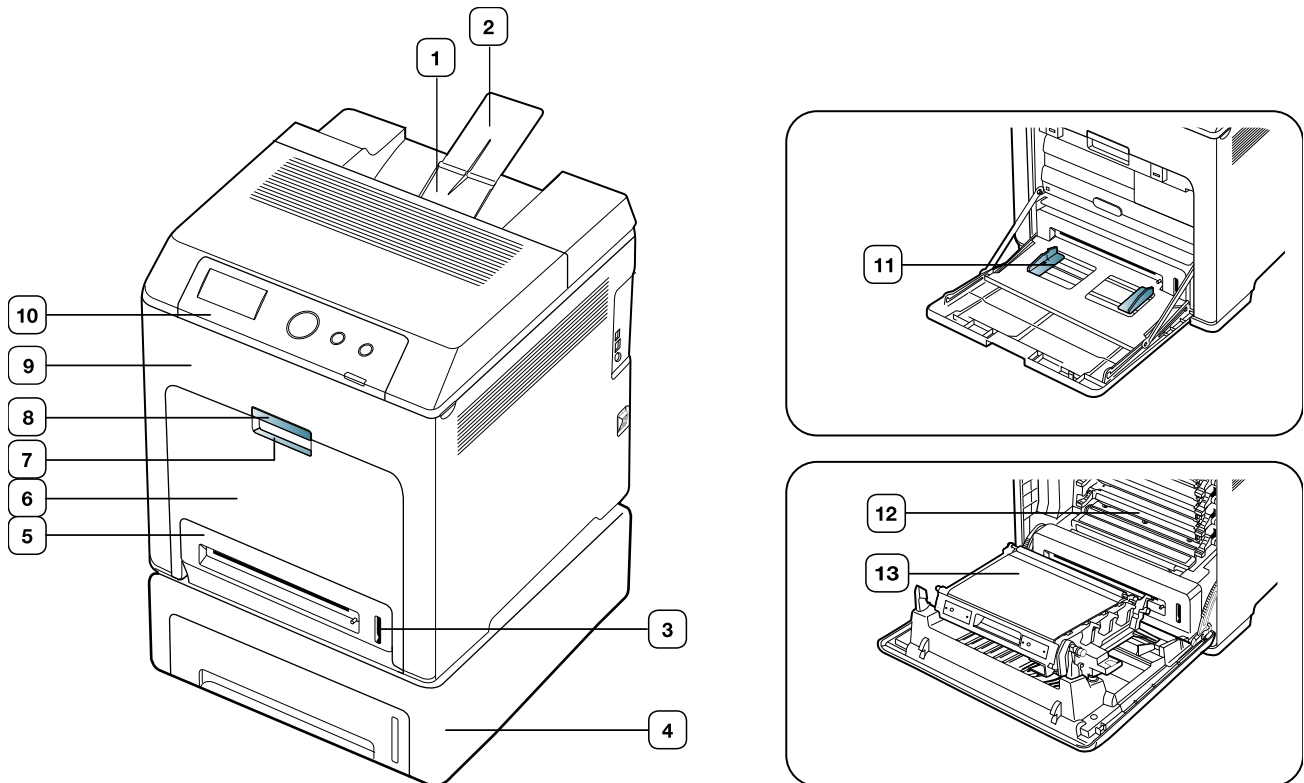

This illustration may differ from your machine depending on its model.

1	Output Tray	8	Front Cover Handle
2	Output Support	9	Front Cover
3	Paper Level Indicator	10	Control Panel
4	Optional Tray *	11	Multi-Purpose Tray Paper Width Guide
5	Tray 1	12	Toner Cartridge
6	Multi-Purpose Tray	13	Paper Transfer Belt (PTB)
7	Multi-Purpose Tray Handle		

\* : This is an option feature.

### 2.2.2. Rear View

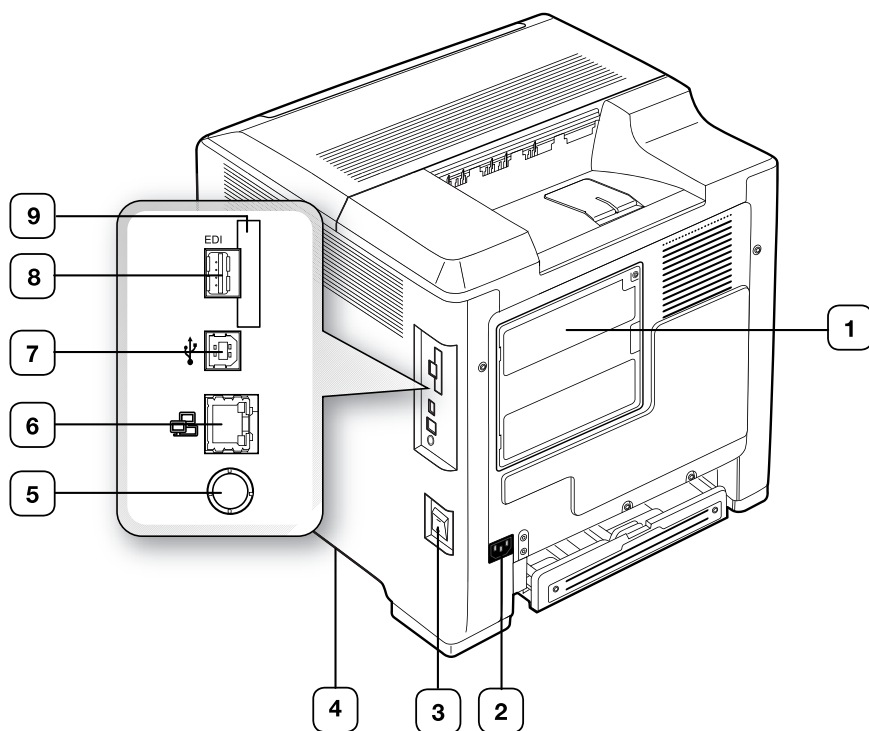

This illustration may differ from your machine depending on its model.

1	Control Board cover	6	Network Port
2	Power receptacle	7	USB Port
3	Power-Switch	8	External device interface (EDI)*
4	Handle	9	IEEE 802.11 b/g/n Wireless LAN**
5	IEEE1284 Parallel Connector		

\* : External device interface for Samsung and third party solutions.

\*\* : This is an optional feature.

### 2.2.3. Paper Path

The following diagram displays the path the paper follows during the printing process.

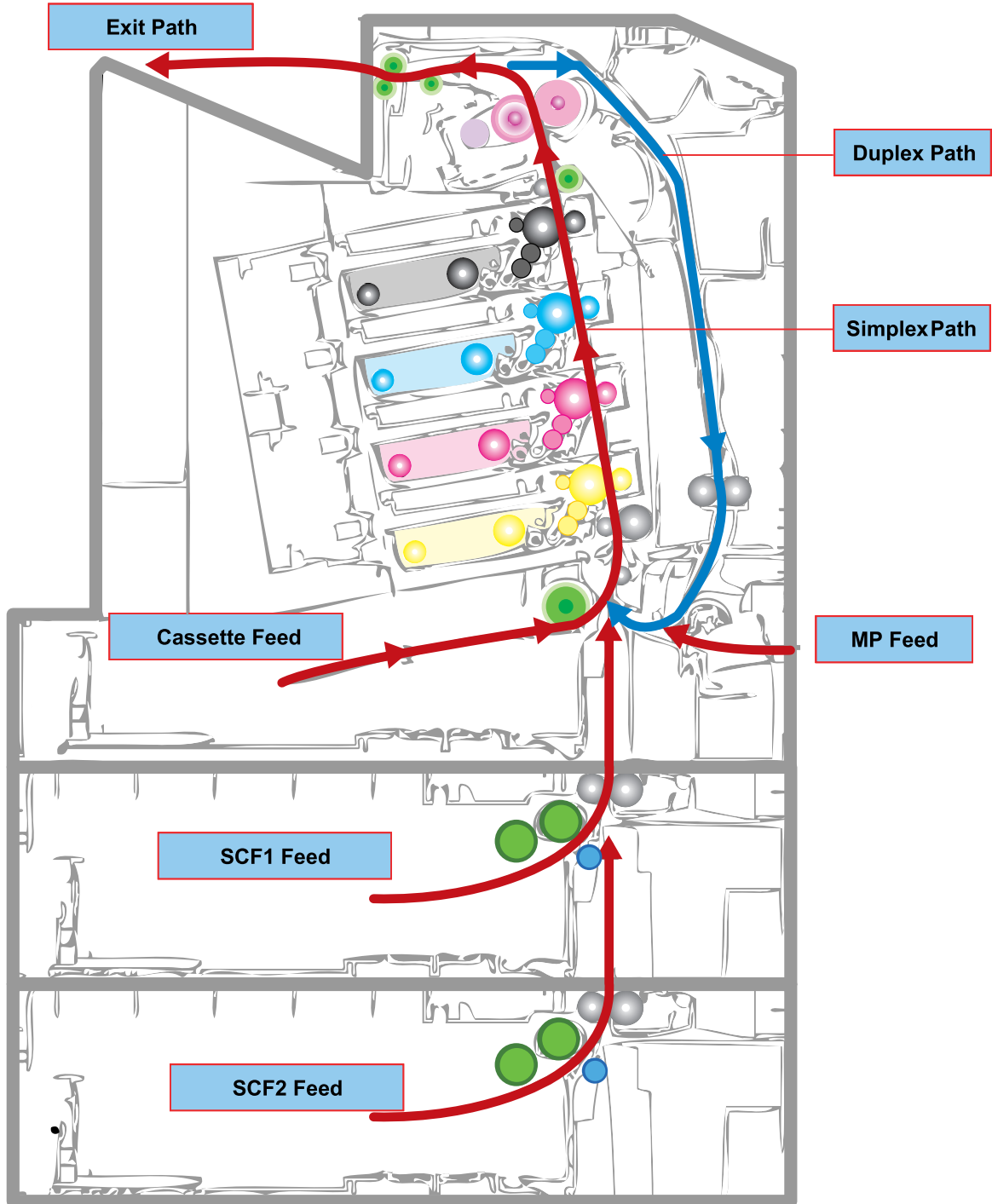

### 2.2.4. System Layout

This model consists of the mechanical parts and hardware parts. Mechanical parts consists of Frame, Feeding, Developing, Driving, Transferring, Fusing. Hardware parts consists of the main control board, SMPS board, HVPS board, Fuser control board, operation panel, PC Interface.

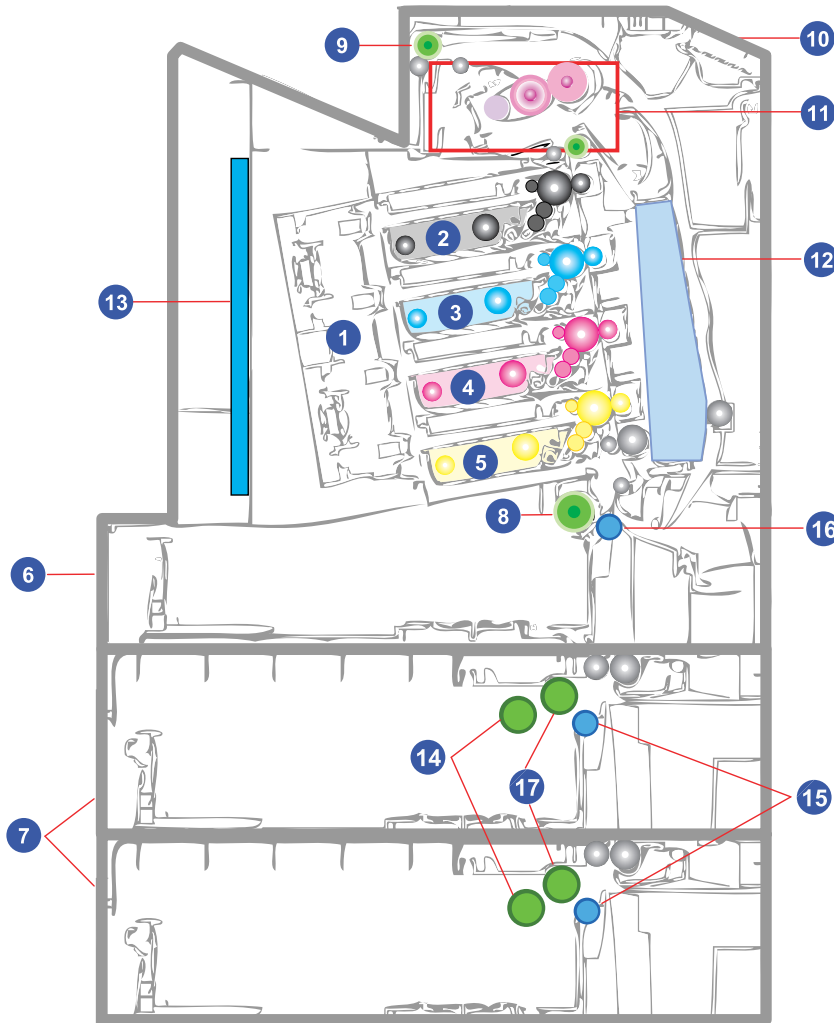

No	Name	No	Name
1	LSU	10	OPE Unit
2	Toner Cartridge (K)	11	Fuser Unit
3	Toner Cartridge (C)	12	Paper Transfer Unit (PTB)
4	Toner Cartridge (M)	13	Main board / SMPS board / Fuser Drive Board (FDB)
5	Toner Cartridge (Y)	14	Pick-Up Roller
6	Tray1 (Basic Tray)	15	Retard Roller
7	SCF Unit (Optional)	16	Retard Roller
8	Pick-Up Roller	17	Pick-Up Roller
9	Exit Roller		

### 2.2.4.1. Feeding Section

It consists of a basic cassette, an MP tray for supplying different types of media (envelope, label, special paper) and parts related to paper transferring.

#### 1) Tray 1 (Basic Tray)

This model has a cassette type tray.

It takes a center loading method and applies 'semi retard separating method.'

It has a paper existence sensing function, paper arranging function.

In the front side, there is a paper level indicator.

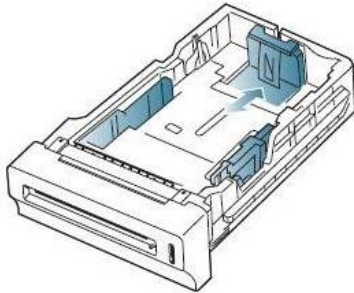

#### 2) Pick- up roller

It is to start the initialization of paper feed out of the Cassette Tray, and subsequent transport to the Registration Rollers. The Pick-up roller is driven by a solenoid.

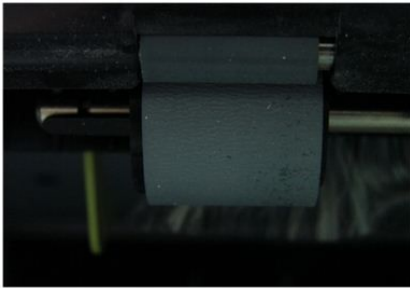

#### 3) Registration Roller

It is used as the primary Registration Roller, which is used to time the paper with the visibly toner image on the Transfer Belt ; it is used as an anti skew device as well.

#### 4) MP Tray

The multi-purpose tray can hold special sizes and types of print material, such as postcards, note cards, and envelopes. It is useful for single page printing on letterhead or colored paper.

#### 5) SCF (Second Cassette Feeder, 2nd / 3rd tray)

SCF is the option unit of CLP-775ND. This additionally stores and automatically feeds printing paper. Its function is the same as the Cassette (1st tray). This SCF can be installed until Max. 2 ea.



### 2.2.4.2. Fuser Unit

---

This unit consists of Heat Roller, a Thermostat, and Thermistors, etc. It fuses the toner that was transferred by the transfer roller onto the paper, by applying pressure and high temperature to complete fusing process.

- Fusing Type : [Dual Lamp Heating, 800W/500W]
- Heat Roller : Pipe Type (Lamp Inside)

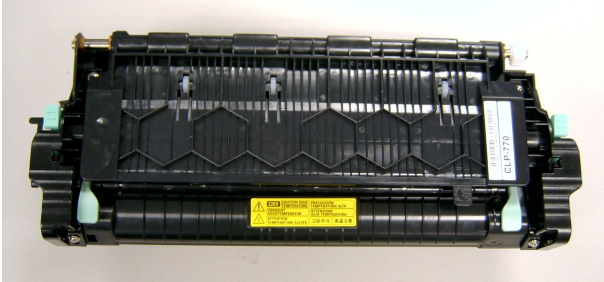

#### 1) Thermostat

When a heat lamp is overheated, a Thermostat cuts off the main power to prevent over-heating.

- Thermostat Type : Non- Contact type

#### 2) Thermistor

It is a temperature detecting sensor.

#### 3) Fuser Belt

The fuser belt transfers the heat from the lamp to apply a heat on the paper. The surface of the fuser belt is coated with Teflon, so toner does not stick to the surface.

#### 4) Pressure roller

A pressure roller mounted under a heat roller is made of a silicon resin, and the surface also is coated with Teflon. When a paper passes between a heat roller and a pressure roller, toner adheres to the surface of a paper and is permanently fused.

### 2.2.4.3. Drive Unit

This product have many motors. These motors drive the PTB unit, fuser unit, feeder unit, exit unit, etc.

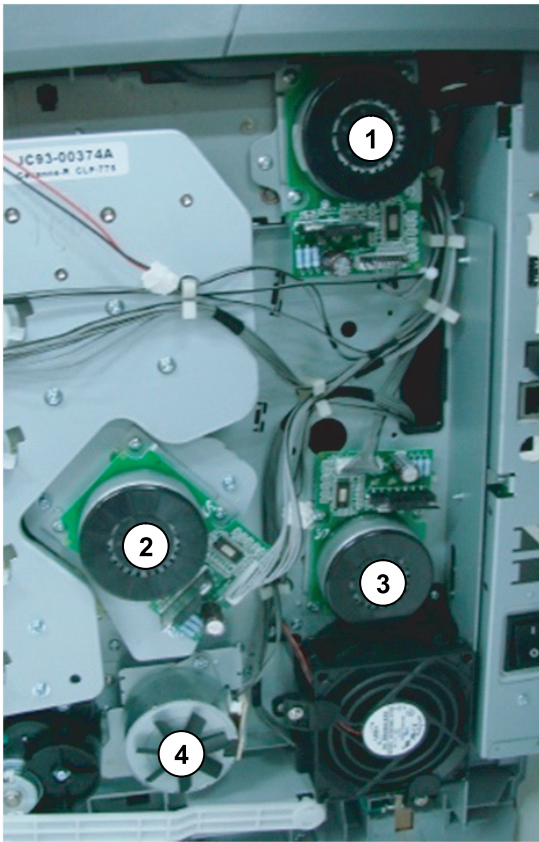

No	Motor	Function
1	BLDC Motor	For Fuser Unit
2	BLDC Motor	For OPC Drive Unit
3	BLDC Motor	For DEVE Drive Unit
4	Step Motor	For Feed Drive Unit

**2.2.4.4. LSU (Laser Scanner Unit)**

It is the core part of the LBP which switches from the video data received to the controller to the electrostatic latent image on the OPC drum by controlling laser beam, exposing OPC drum, and turning principle of polygon mirror. The OPC drum is turned with the paper feeding speed. The /HSYNC signal is created when the laser beam from LSU reaches the end of the polygon mirror, and the signal is sent to the controller. The controller detects the /HSYNC signal to adjust the vertical line of the image on paper. In other words, after the /HSYNC signal is detected, the image data is sent to the LSU to adjust the left margin on paper. The one side of the polygon mirror is one line for scanning.

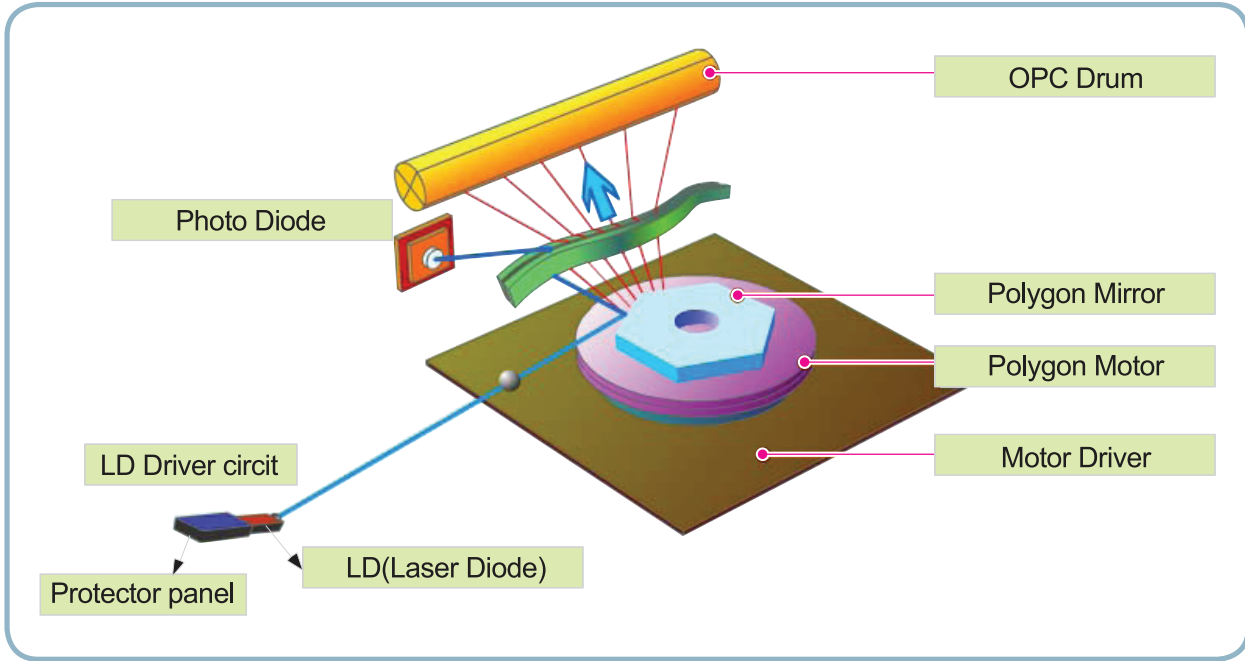

Trouble	Failure Analysis
Polygon Motor Error	The Rotation of Polygon Motor can not reach stable.
Hsync Error	Though the rotation of Polygon Motor reach stable, the signal of Hsync is not occurred.



### 2.2.4.5. PTB (Paper Transfer Belt) Unit

This unit consists of a transfer belt, transfer roller, duplex unit, waste toner tank, etc. The transfer belt carries the printing paper through OPC drums of each color. As the paper and transfer belt pass between the transfer roller and the OPC drum, the negatively charged toner images formed on OPC drum are transferred to the printing medium paper by positive bias applied to the transfer roller. The toner images transferred to the paper are melted down and fixed on the paper by the fusing system.

- Belt Cleaning : Collect the toner by using Rubber Blade
- Management of wasted toner : The Waste Toner Tank is equipped.
- Life Span : 50,000 images (Declared yield value in accordance with ISO/IEC 24712)
- Transfer Voltage Control : ADC Control on Conductive Sponge Roller



### 2.2.4.6. Toner Cartridge

---

By using the electronic photo process, it creates a visual image. Each toner cartridge consists of the OPC unit and the developing unit. The OPC unit has OPC drum and charging roller, and the toner cartridge unit has toner, supply roller, developing roller, and blade (Doctor blade)

- Developing method: Non-magnetic one-component non-contacting method
- Toner: Non magnetic one-component pulverized toner
- The expected life of toner cartridge : 7,000(YMCK) pages (N/N, Simplex, ISO/IEC 24712 standard pages)
- OPC Cleaning: Collect the toner by using Cleaning Blade
- Method of Toner supply : Toner is carried to the developing roller by supply belt.

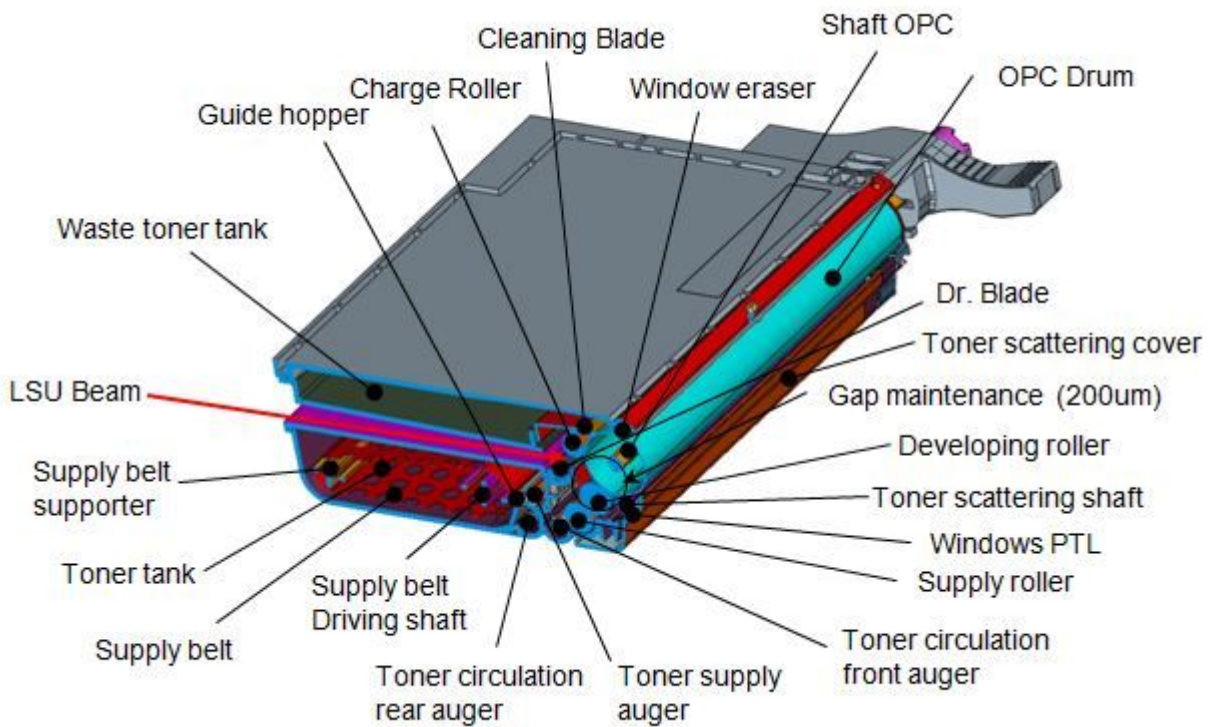

## 2.2.5. Hardware Configuration

The CLP-775ND Electrical Circuit System consists of the following:

- Main board
- SMPS board
- HVPS board and HVPS sub board
- Fuser Drive board
- OPE board

CLP-775ND Block Diagram

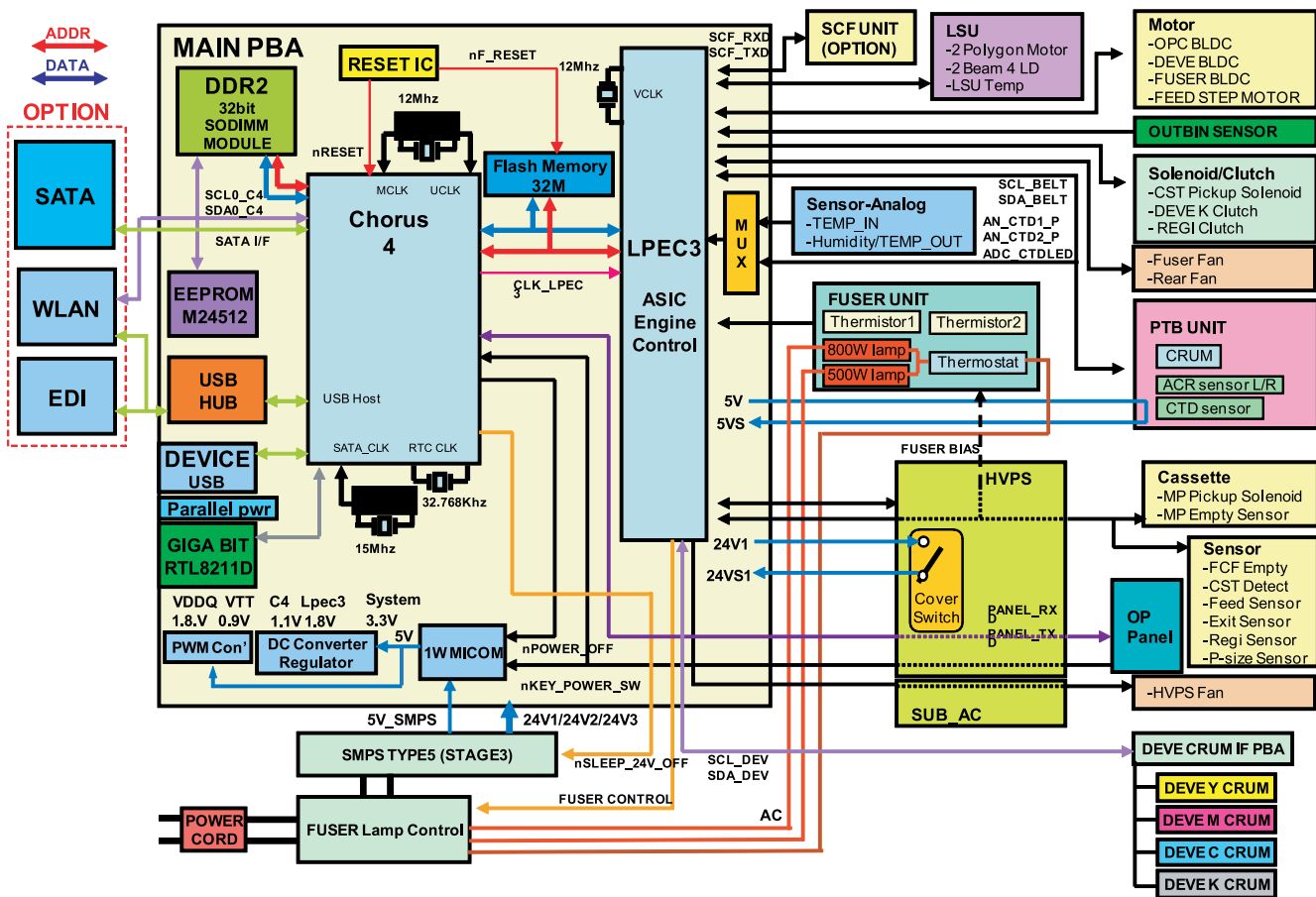

**2.2.5.1. Main PBA**

The CLP-775ND system controller consists of a main controller and an engine controller in one-board. The main controller uses a ARMS core chip as main processors, which are dedicated for printing several internal operating blocks through system programs stored in Flash Memory. The engine controller has an engine control SoC, which includes motor drivers, PWM drivers, LSU drivers, sensors, high-voltage drivers, and other driving units for mechanical parts.

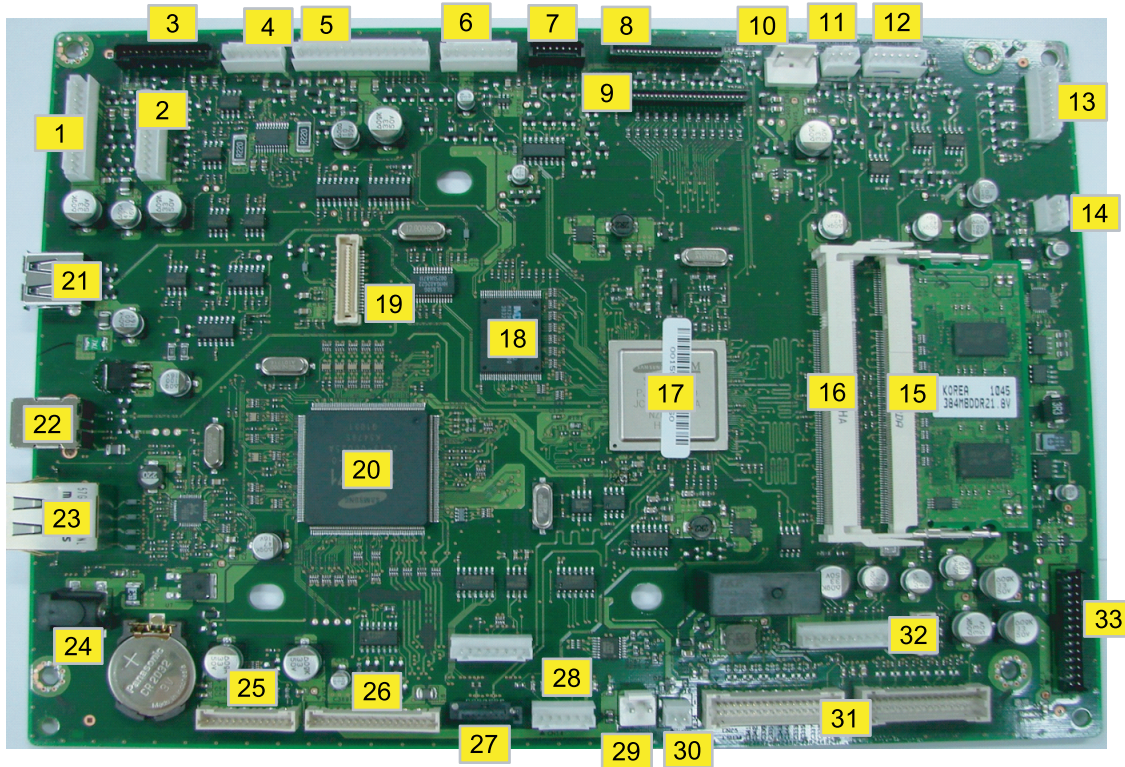

NO	Connector	NO	Connector	NO	Connector
1	DEVE BLDC 12pin	12	FUSER THERMISTOR 6pin	23	NETWORK JACK
2	OPC BLDC 10pin	13	PTL 8pin	24	DC JACK
3	PTB 14pin	14	FAN Rear 3pin	25	MHV 12pin
4	FEED Motor 6pin	15	BASE DIMM	26	SCF I/F 18pin
5	FUSER BLDC 15pin	16	OPTION DIMM	27	HDD SATA 7pin
6	HUMIDITY sensor 8pin	17	Chorus4 asic	28	FUER HEAT CTL 6pin
7	DEVE CRUM 7pin	18	32MB Flash memory	29	HDD PWR 2pin
8	HVPS Interface 23pin	19	WLAN	30	LSU Temp 2pin
9	HVPS Interface 30pin	20	LPEC3 ASIC	31	LSU 32pin/34pin
10	Cover open 2pin	21	HOST JACK	32	LSU PWR 10pin
11	OUTBIN Sensor 3pin	22	USB JACK	33	SMPS 28pin

## CPU

- 1) ARM v5TE compliant core 800MHz (I-Cache : 32KB, D-Cache : 32KB)

## Memory

- 1) ROM
  - Nor Flash used (32MB)
  - Interface With Chorus4 ROM Controller
- 2) SDRAM
  - Size : CLP-775ND(DDR2) : Default 384 MB (Option 512MB)
- 3) EEPROM
  - Size : 512KB
  - Interface With SPGPV4 I2C Controller
- 4) SDRAM
  - Size : 256 Byte

## I/O Interface

- 1) USB
  - DEVICE : High Speed USB 2.0 (High speed 480Mbps)
  - Host : J-SCRIBE Enabler Kit (Full speed 12Mbps)
- 2) N/W Embedded
  - Chorus4 With MII Interface
  - Active LED(Yellow) / Link LED(Green)
- 3) PWM
  - High Voltage Control With Duty
  - Main Motor Clock
- 4) I2C Interface
  - NVRAM (system information + network information)
  - CRUM

**2.2.5.2. SMPS board**

SMPS( Switching Mode Power Supply ) Board supplies electric power to a Main Board and other boards through a Main Controller by +5V,+24V from 110V/220V power input. It has safety protection modes for over current and load.

- Specification
  - AC 110V (90V ~ 135V) / AC 220V (180V ~ 270V)
  - Output Power: 192W / Max. 270W
  - DC 5V: 24W ~ 30W / DC 24V: 168W ~ 240W

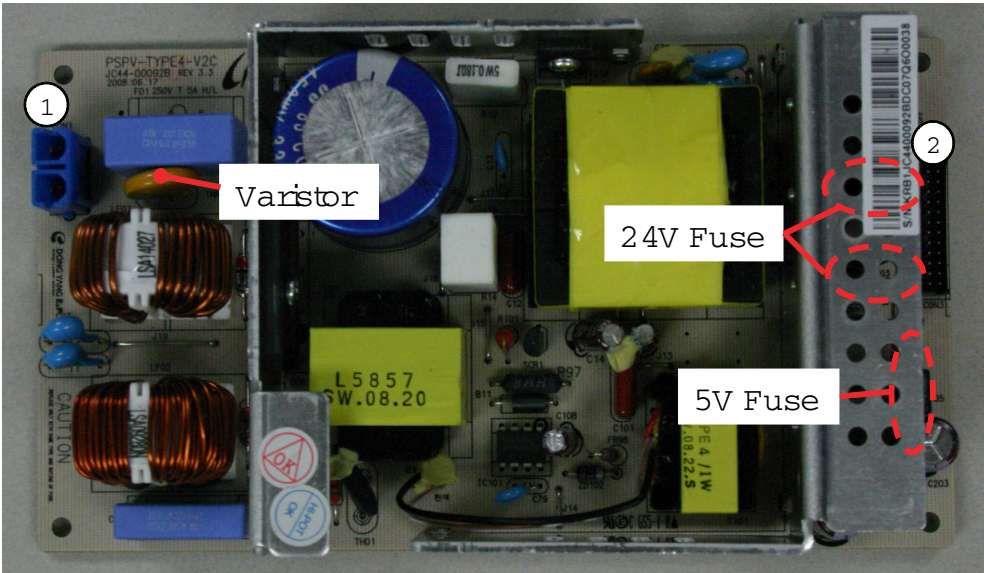

■ Connection

1	INPUT_AC (Fuser Drive Board )
2	OUTPUT_5V , 24V (Main PBA) INPUT_24V_Control (Main PBA )

**Input / Output connector**

AC Input Connector( CN1 )		
PIN ASSIGN	PIN NO	Description
1	AC_L	AC Input
2	AC_N	

AC Input Connector (CN1)					
Description	PIN NO	PIN ASSIGN		PIN NO	Description
Power	+24V1	1	2	GND	24V Ground
Power	+24V1	3	4	+24V1	Power
24V Ground	GND	5	6	GND	24V Ground
Power	+24V2	7	8	GND	24V Ground
Power	+24V2	9	10	+24V2	Power
24V Ground	GND	11	12	GND	24V Ground
Power	+24V3	13	14	GND	24V Ground
Power	+24V3	15	16	GND	24V Ground
5V Ground	GND	17	18	GND	5V Ground
Power	+5V1	19	20	GND	5V Ground
Power	+5V1	21	22	+5V1	Power
5V Ground	GND	23	24	GND	5V Ground
Power	+5V2	25	26	+5V2	Power
Signal	Standby	27	28	reserved	Signal(reserved)

**2.2.5.3. HVPS Board**

HVPS (High Voltage Power Supply) Unit generates 16 high-voltage channels which includes T1(4), Charger(1), Deve AC(4), Supply DC(4), Fuser Bias(1), ATTR(2) HVPS has Cover Open switch and some connectors ( from Ope PBA, feed, exit, regi, cst empty, paper size, cst detect, MP empty sensor, MP clutch) and Erase Lamp 4EA.

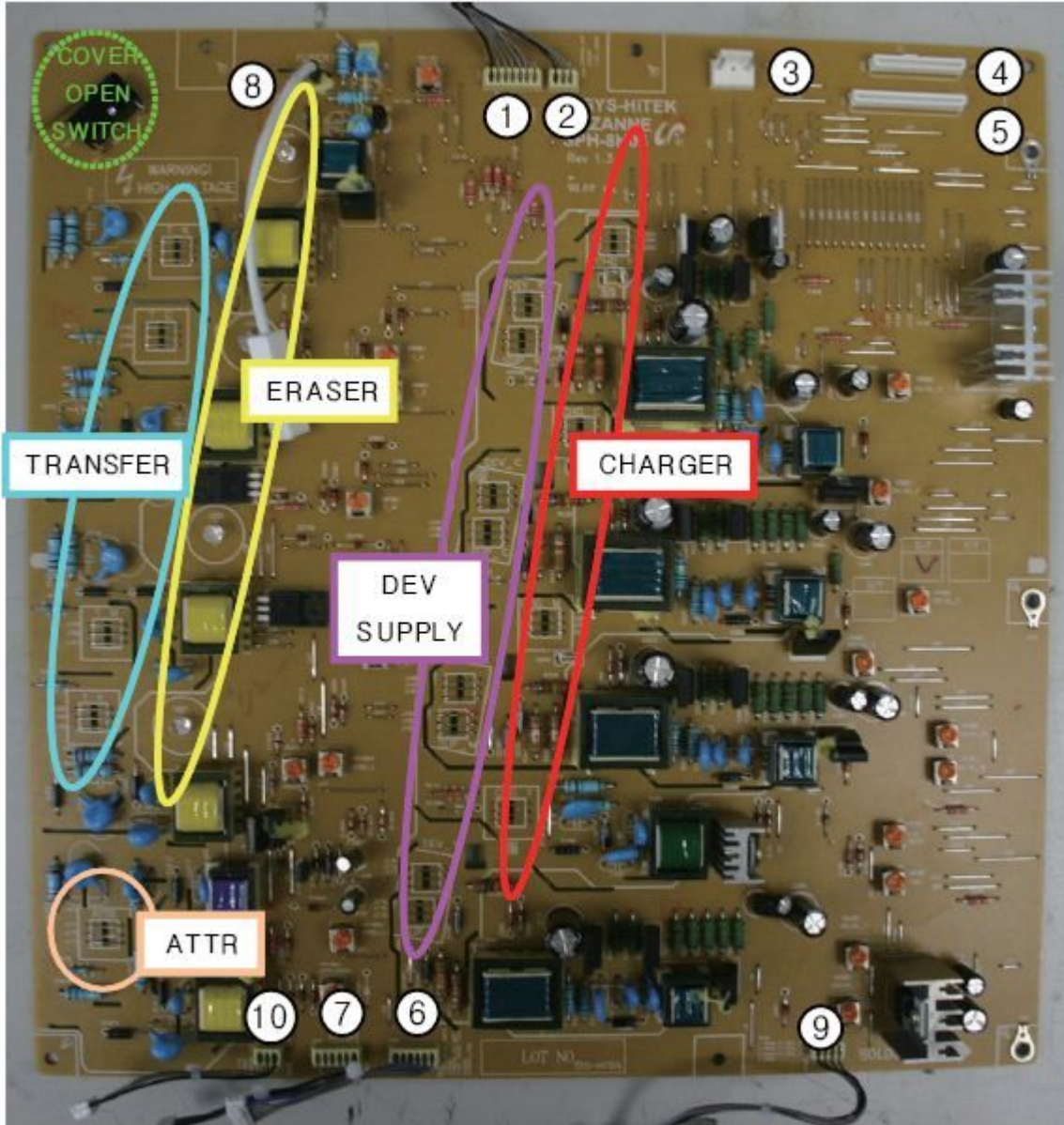

**Connection**

1	PANEL	6	Feed, CST empty sensor
2	EXIT SENSOR	7	MP solenoid, MP empty, CST detect
3	24V SWITCH	8	Fuser bias
4	HVPS1(from mainboard)	9	Paper size
5	HVPS2(from mainboard)	10	Regi sensor



**Specification**

Output	Input Duty (EDC mode display)	Output Voltage/Current	Load	Read voltage (ADC)	Tolerance
CHARGER Y,M,C,K	0~255	-1170V	200M	0.7V(54)	3%
SUP DC Y,M,C,K		-295V	68pF	-	3%
DEVE AC Y,M,C,K		174.0V (about 1740V) [AC JIG]	68pF	-	1.50%
Transfer_Y,M,C,K		14uA	90M	1.84V (142)	3%
ATTR		1418V	100M	0.85V (66)	3%
ATTR[-]		-800V	25M	-	15%
Fuser Bias		418V	100M	-	3%
Eraser Y,M,C,K		on/off (18mA±3mA)	-	-	-

- Constant current outputs in T1 channels.
- Individual T1 channels for each color.
- AC + DC deve high voltage.
- 1 Chanel charger output to each 4 color's port.
- All output channels can be adjusted by using volume control components.

### 2.2.5.4. HVPS sub board

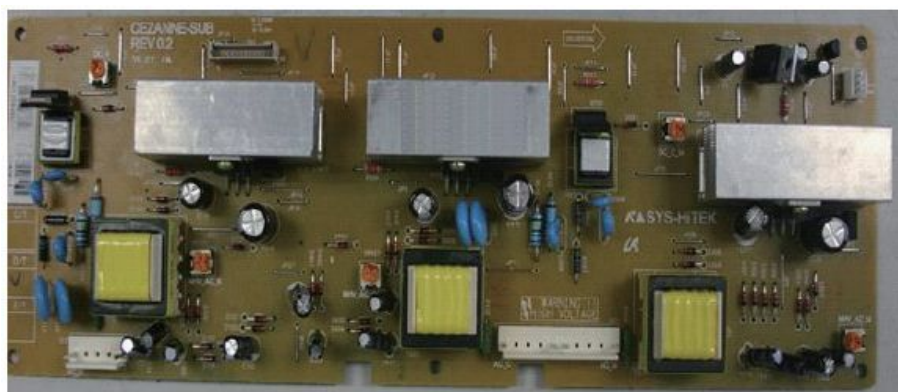

#### Connection

1	AC Control
2	Charger-K
3	Charger-M,C
4	Fan

#### Specification

##### 1) MHV AC\_M,C,K

Item	Specification	Condition	
Rated output voltage	Temp. Humid.	DC 134.6V±3%	Rated input , 250pF load Read AC value by using a AC_DC converting Jig.
	Environment	DC 134.6V±3%	
Output voltage Setting	134.6V	Rated input, 250pF load	

##### 2) MHV DC\_M,C,K

Item	Specification	Condition
Rated output voltage	-1300V±3%	Rated input , 30 Input
Output RIPPLE & Noise	Less than 50Vp-p	Rated input , 30 Input
Output voltage SETTING	-1300V	Rated input , 30 Input

### 2.2.5.5. Fuser Drive Board

The FDB (Fuser Drive Board) controls 2 halogen lamps in the fuser unit using control signals which are provided from the main board and supplies AC power to the SMPS. Both V1/V2 FDBs provide max. 1500W output power.

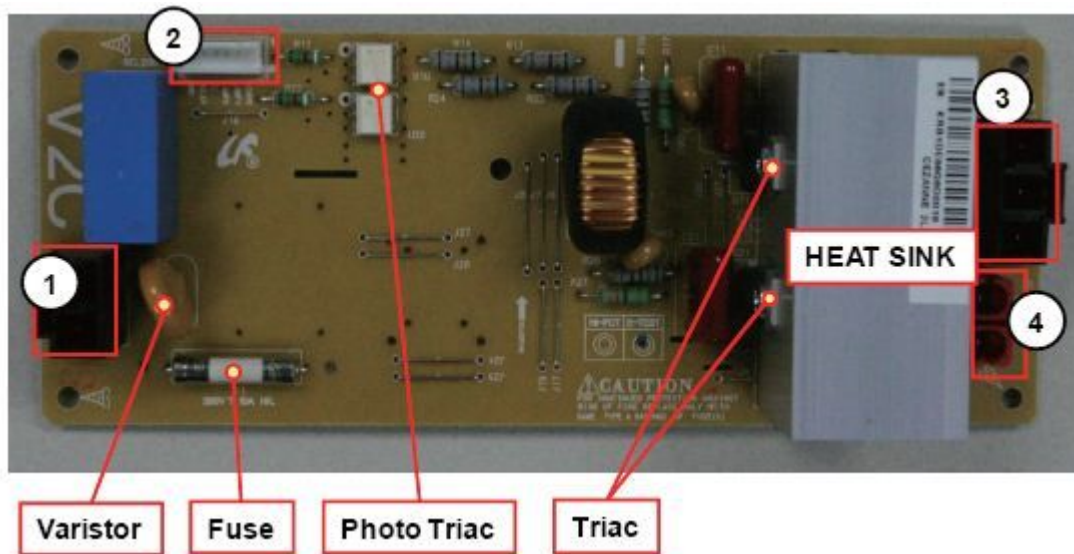

#### ■ Connection

1	INLET AC
2	FUSER CONTROL (from Main board)
3	FUSER AC (to Fuser lamp)
4	SMPS AC ( to SMPS)

#### ■ Specification

	V1	V2
Input Voltage(Range)	AC 110V (90 ~ 135V)	AC 220V (180 ~ 270V)
Input Current	20A	10A
Output Power	Max. 1500W	Max. 1500W
Phase Detect	Not support	
Protection	Relay Control Signal	

### 2.2.5.6. OPE Board

The OP PBA controls the 4 Line Graphic LCD(128 x 64 Dots) unit, and communicates with Main PBA through UART. The OP PBA includes an 8-Bit CMOS Micom(S3F828B) and a Power Key. With the OPE Power Key, user can turn on & off the set(CLP-775ND).

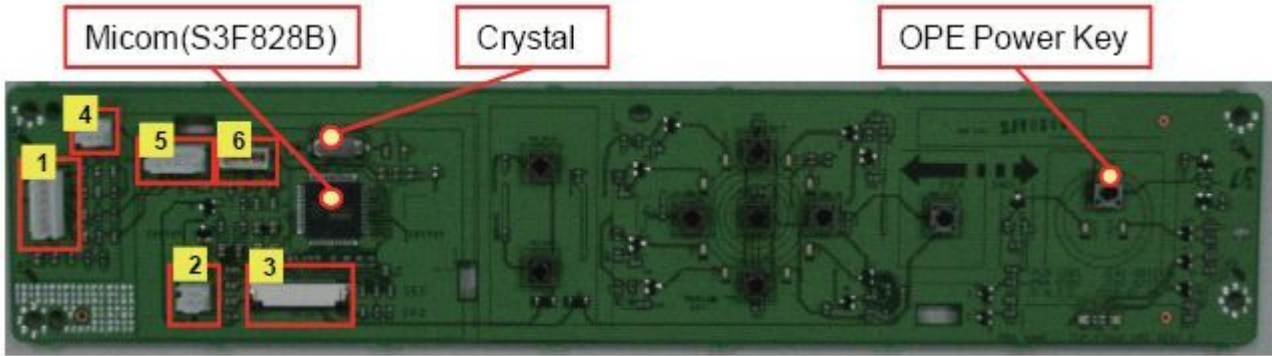

#### ■ Connection

1	Main IF
2	LCD Back Light IF
3	LCD IF
4	For Download
5	For Download
6	For Debug

**2.2.5.7. Sensor**

The picture below shows the location of sensors in the machine.

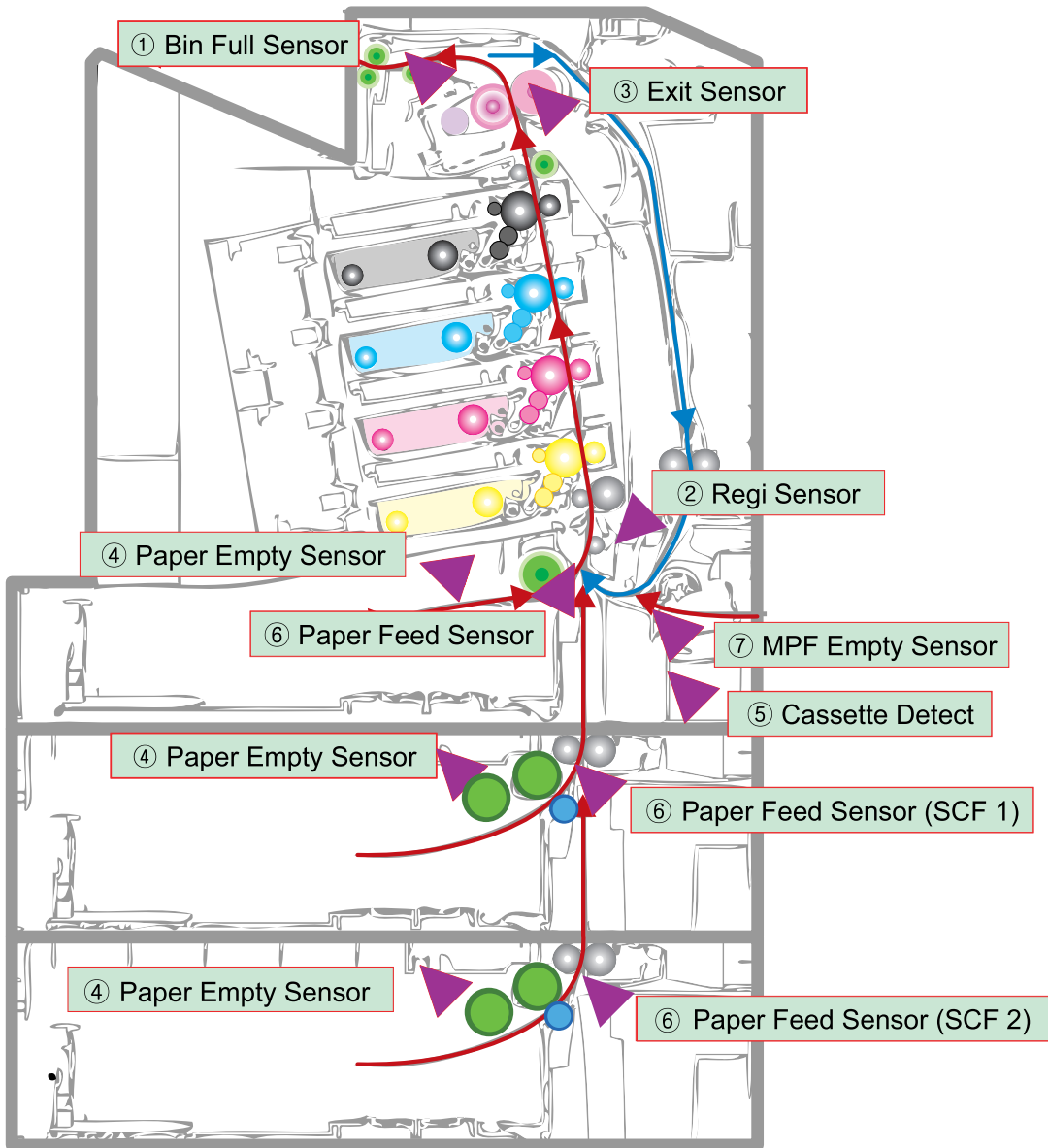

No.	Name	Description
1	Bin Full Sensor	Check overflowing of Paper on Stacker
2	Regi Sensor	Two Regi Sensor for checking precise paper position
3	Exit Sensor	Check paper position on Fuser
4	Paper Empty Sensor	Check Paper empty on a cassette
5	Cassette Detect	Check cassette insertion
6	Paper Feed Sensor	Check paper position
7	MPF Empty Sensor	Check paper empty on MPF

**Sensor (Expansion)**

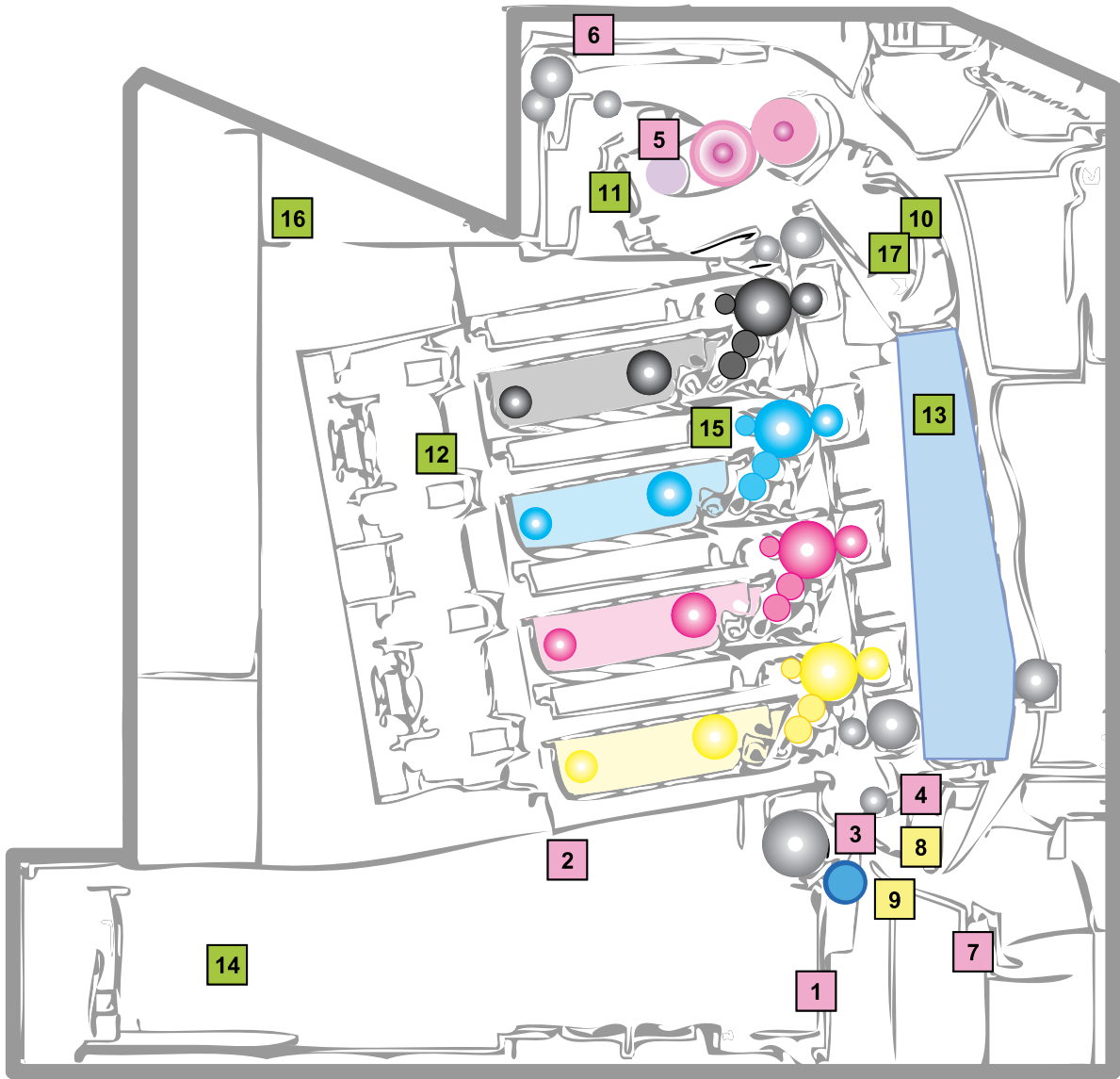

1	CASSETTE_DETECT	10	SENS_ACR
2	PAPER_EMPTY	11	THERMOSTAT
3	SENS_FEED	12	CRUM_DEVE_Y(M/C/K)
4	SENS_REGI	13	CRUM_PT
5	SENS_PAPER_EXIT	14	PAPER_SIZE1(2/3)
6	OUTBIN_FULL	15	INNER_TEMP
7	MP_EMPTY	16	SENS_HUMIDITY OUT_TEMP
8	CLUTCH_FEED	17	SENS_CTD
9	CLUTCH_PICKUP		

## 2.2.6. Software Descriptions

### 2.2.6.1. Overview

The software of CLP-775ND system is constructed with

- 1) Host Software part that the application software operated in Window and Web Environment, and
- 2) Firmware parts that is a Embedded software controls printing job.

### 2.2.6.2. Architecture

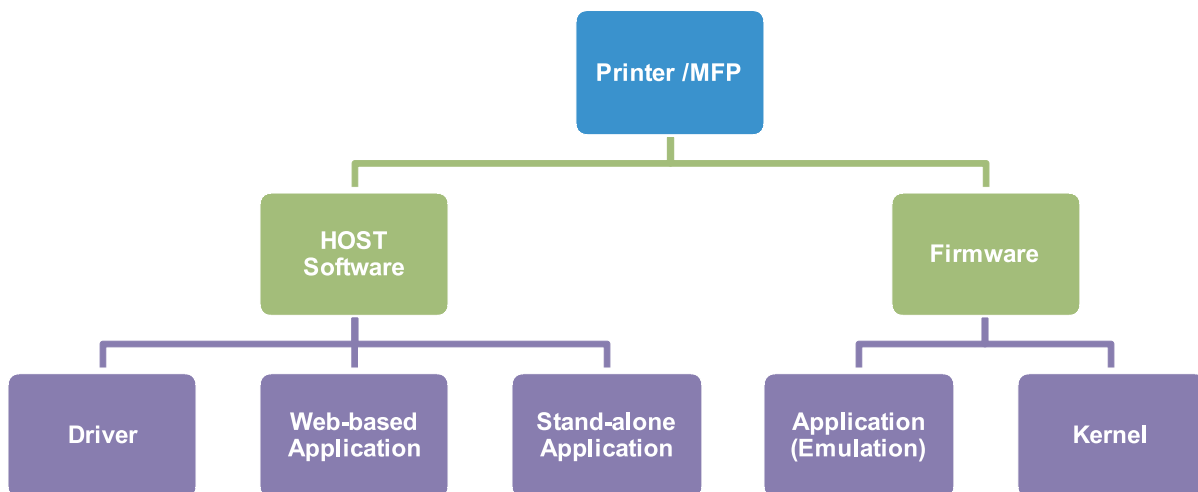

- **Host Software is made up of**

- 1) Graphic User Interface that offers the various editing functions to user in Host.
- 2) Driver that translates the received document to a Printing Command language which printer can understand and transfers data to spooler.
- 3) Stand-alone Application that offers the various printing application, PSU(Printer Settings Utility), Printer Status Monitor in Window system.

- **Firmware is made up of**

- 1) Application (Emulation) that is a interpreter translate data received from Host to a printing language (PCL, PS, etc.) to be able to make the user to take same output as originally one what composed in Host.
- 2) Kernel that control and management the whole procedure include of Control flow and Printing Job before transfer to Engine system.

2.2.6.3. Data and Control Flow

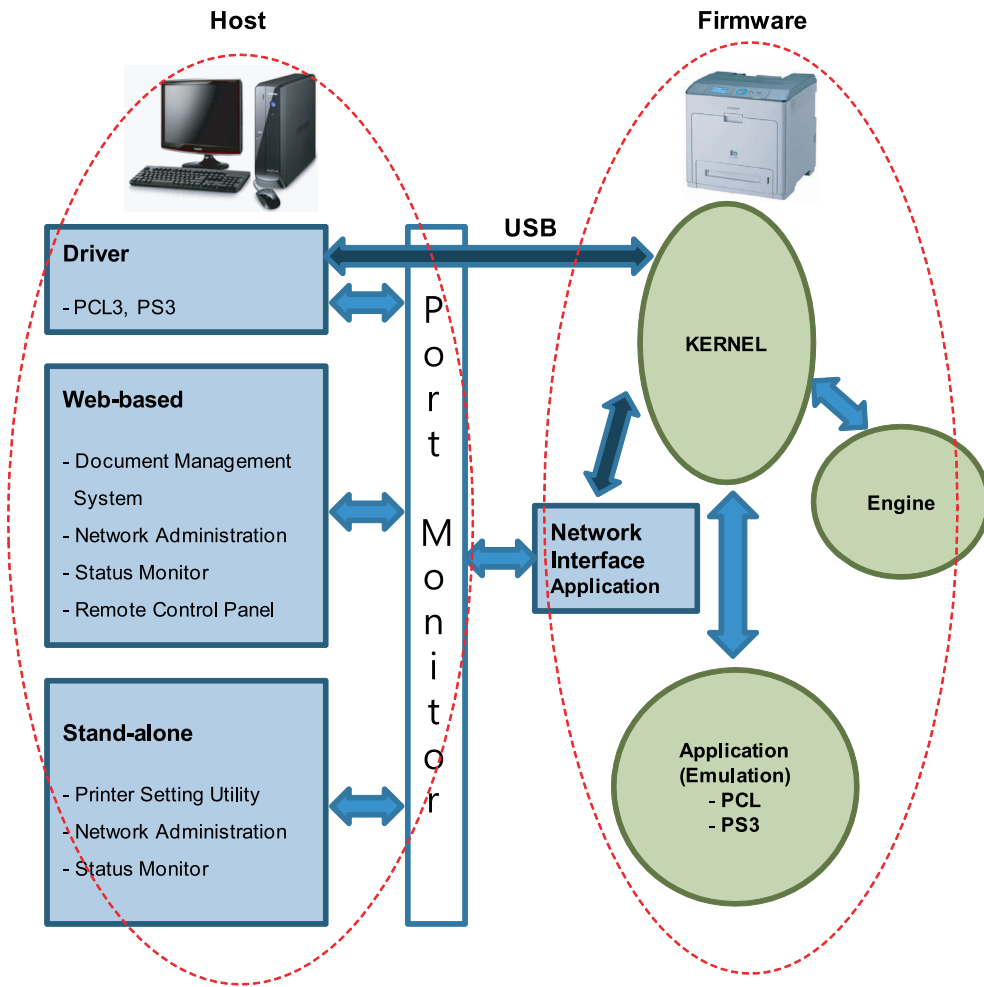

• Host Side is made up of :

- 1) Driver that is Windows application software translates printed data to one of printer language and create the spooler file.
- 2) Web-based Application that offer a various printer additional functions, management of printing job, printer administration, Status monitor to monitoring the printer status by real time in Web, independent environment on OS.
- 3) Stand-alone Application that is a similar Window software, as number 2 above.
- 4) Port Monitor that manages the network communication between spooler and Network Interface Card, or various additional application and Network Interface Card.(this is, at first, make communication logical port, manages the data, transfers them from spooler to network port, and the manages the printing as well.)

• Firmware Side is made up of :

- 1) Network Interface Application relays the communication between Host and kernel using various network protocol.
- 2) Kernel manages the flow control of the emulation procedure, the receiving of data from Host or Network application and rendering and printing in the with engine.
- 3) Emulation is that interprets the various output data from selected emulation.
- 4) Engine prints rendered bit-map data to paper with required size and type by Kernel. And then, for Job Spooling function for Multi-User, Multi-Printing that is occurred in Network printing and various additional printing functions, this Kernel uses max. 10 Queuing systems in memory.



---

## 3. Disassembly and Reassembly

---

### 3.1. Precautions when replacing parts

---

#### 3.1.1. Precautions when assembling and disassembling

---

- Use only approved Samsung spare parts. Ensure that part number, product name, any voltage, current or temperature rating are correct. Failure to do so could result in damage to the machine, circuit overload, fire or electric shock.
- Do not make any unauthorized changes or additions to the printer, these could cause the printer to malfunction and create electric shock or fire hazards.
- Take care when dismantling the unit to note where each screw goes. There are 19 different screws. Use of the wrong screw could lead to system failure, short circuit or electric shock.
- Do not disassemble the LSU unit. Once it is disassembled dust is admitted to the mirror chamber and will seriously degrade print quality. There are no serviceable parts inside.
- Regularly check the condition of the power cord, plug and socket. Bad contacts could lead to overheating and fire. Damaged cables could lead to electric shock or unit malfunction.

#### 3.1.2. Precautions when handling PBA

---

Static electricity can damage a PBA, always use approved anti-static precautions when handling or storing a PBA.

- **Precautions when moving and storing PBA**
  - 1) Please keep PBA in a conductive case, anti-static bag, or wrapped in aluminum foil.
  - 2) Do not store a PBA where it is exposed to direct sunlight.
- **Precautions when replacing PBA**
  - 1) Disconnect power connectors first, before disconnecting other cables.
  - 2) Do not touch any soldered connections, connector terminals or other electronic parts when handling insulated parts.
- **Precautions when checking PBA**
  - 1) Before touching a PBA, please touch other grounded areas of the chassis to discharge any static electrical charge on the body.
  - 2) Take care not to touch the PBA with your bare hands or metal objects as you could create a short circuit or get an electric shock. Take extra care when handling PBAs with moving parts fitted such as sensors, motors or lamps as they may get hot.
  - 3) Take care when fitting, or removing, screws. Look out for hidden screws. Always ensure that the correct screw is used and always ensure that when toothed washers are removed they are refitted in their original positions.

### 3.1.3. Releasing Plastic Latches

---

Many of the parts are held in place with plastic latches. The latches break easily; release them carefully.

To remove such parts, press the hook end of the latch away from the part to which it is latched.



## 3.2. Screws used in the printer

The screws listed in the table below are used in this printer. Please ensure that, when you disassemble the printer, you keep a note of which screw is used for which part and that, when reassembling the printer, the correct screws are used in the appropriate places.

Part Code	Location	Description	Qty
6003-000196	FRAME-RIGHT	SCREW-TAPTYPE;PWH,+,B,M3,L10,NI PLT,SWRCH18A	2
6003-000196	SENSOR-HUM	SCREW-TAPTYPE;PWH,+,B,M3,L10,NI PLT,SWRCH18A	1
6003-000196	SUPPORT-L	SCREW-TAPTYPE;PWH,+,B,M3,L10,NI PLT,SWRCH18A	2
6003-000196	SUPPORT-R	SCREW-TAPTYPE;PWH,+,B,M3,L10,NI PLT,SWRCH18A	2
6003-000269	BRKT-OPE_L	SCREW-TAPTYPE;BH,+,-,S,M3,L6,ZPC(WHT),SWRCH18A,-	2
6003-000269	DUCT-FUSER	SCREW-TAPTYPE;BH,+,-,S,M3,L6,ZPC(WHT),SWRCH18A,-	2
6003-000269	FEED-DRIVE	SCREW-TAPTYPE;BH,+,-,S,M3,L6,ZPC(WHT),SWRCH18A,-	3
6003-000269	FRAME-BOTTOM	SCREW-TAPTYPE;BH,+,-,S,M3,L6,ZPC(WHT),SWRCH18A,-	2
6003-000269	FRAME-BOTTOM,LSU	SCREW-TAPTYPE;BH,+,-,S,M3,L6,ZPC(WHT),SWRCH18A,-	4
6003-000269	FRAME-L	SCREW-TAPTYPE;BH,+,-,S,M3,L6,ZPC(WHT),SWRCH18A,-	7
6003-000269	FRAME-R	SCREW-TAPTYPE;BH,+,-,S,M3,L6,ZPC(WHT),SWRCH18A,-	10
6003-000269	FRAME-TOP	SCREW-TAPTYPE;BH,+,-,S,M3,L6,ZPC(WHT),SWRCH18A,-	16
6003-000269	FRAME-TOP, FRAME-LSU	SCREW-TAPTYPE;BH,+,-,S,M3,L6,ZPC(WHT),SWRCH18A,-	5
6003-000269	FRAME-TOP,FRAME-R	SCREW-TAPTYPE;BH,+,-,S,M3,L6,ZPC(WHT),SWRCH18A,-	4
6003-000269	SUPPORT-L	SCREW-TAPTYPE;BH,+,-,S,M3,L6,ZPC(WHT),SWRCH18A,-	2
6003-000269	SUPPORT-R	SCREW-TAPTYPE;BH,+,-,S,M3,L6,ZPC(WHT),SWRCH18A,-	3
6006-001193	FEED DRIVE	SCREW-MACHINE;PH,+,WSP,M3,L10,ZPC(WHT),SWRCH18A	2
6003-000196	FRAME MAIN-BOTTOM	SCREW-TAPTYPE;PWH,+,B,M3,L10,NI PLT,SWRCH18A	4
6003-000269	FRAME MAIN-BOTTOM	SCREW-TAPTYPE;BH,+,-,S,M3,L6,ZPC(WHT),SWRCH18A,-	5
6003-000196	FRAME-PICK UP	SCREW-TAPTYPE;PWH,+,B,M3,L10,NI PLT,SWRCH18A	5
6003-000282	FRAME-PICK UP	SCREW-TAPTYPE;BH,+,-,B,M3,L8,ZPC(BLK),SWRCH18A,-	1
6003-000301	DRIVE-PICK UP	SCREW-TAPTYPE;BH,+,S,M4,L6,ZPC(WHT),SWRCH18A	2
6003-000269	DRIVE FUSER	SCREW-TAPTYPE;BH,+,-,S,M3,L6,ZPC(WHT),SWRCH18A,-	14
6003-000196	FRAME MAIN-LEFT	SCREW-TAPTYPE;PWH,+,B,M3,L10,NI PLT,SWRCH18A	14
6003-000196	FRAME BASE-LEFT	SCREW-TAPTYPE;PWH,+,B,M3,L10,NI PLT,SWRCH18A	3
6003-000266	ELA UNIT-CST SENSOR	SCREW-TAPTYPE;PWH,+,S,M3,L6,ZPC(WHT),SWRCH18A,-	2
6003-000196	ELA UNIT-PTB_TERMINAL	SCREW-TAPTYPE;PWH,+,B,M3,L10,NI PLT,SWRCH18A	1
6003-000196	FRAME -RIGHT	SCREW-TAPTYPE;PWH,+,B,M3,L10,NI PLT,SWRCH18A	10
6003-000196	STOPPER-FAN	SCREW-TAPTYPE;PWH,+,B,M3,L10,NI PLT,SWRCH18A	2
6003-000269	BRACKET-DEVE_DR	SCREW-TAPTYPE;BH,+,-,S,M3,L6,ZPC(WHT),SWRCH18A,-	4
6003-000269	DUCT-FAN	SCREW-TAPTYPE;BH,+,-,S,M3,L6,ZPC(WHT),SWRCH18A,-	3
6003-000269	FRAME-RIGHT	SCREW-TAPTYPE;BH,+,-,S,M3,L6,ZPC(WHT),SWRCH18A,-	19
6003-000301	FRAME MAIN-RIGHT	SCREW-TAPTYPE;BH,+,S,M4,L6,ZPC(WHT),SWRCH18A	4
6006-001193	FRAME MAIN-RIGHT	SCREW-MACHINE;PH,+,WSP,M3,L10,ZPC(WHT),SWRCH18A	14

3. Disassembly and Reassembly

Part Code	Location	Description	Qty
6009-001396	FRAME MAIN-RIGHT	SCREW-SPECIAL;PH,+,M3,L10.3,ZPC(BLK),SWRCH18A,B TITE	2
6009-001492	FRAME MAIN-RIGHT	SCREW-HEX;HWH,+,M3,L8,NI PLT,SWRCH18A,S,RF	4
6003-000196	FRAME BASE-RIGHT	SCREW-TAPTYPE;PWH,+,B,M3,L10,NI PLT,SWRCH18A	5
6003-000196	MEA UNIT-COUPLING OPC	SCREW-TAPTYPE;PWH,+,B,M3,L10,NI PLT,SWRCH18A	1
6003-000196	ELA UNIT-DUCT_FUSER	SCREW-TAPTYPE;PWH,+,B,M3,L10,NI PLT,SWRCH18A	2
6003-000269	ELA UNIT-FRAME_TOP	SCREW-TAPTYPE;BH,+,-,S,M3,L6,ZPC(WHT),SWRCH18A,-	2
6009-001396	ELA UNIT-FRAME_TOP	SCREW-SPECIAL;PH,+,M3,L10.3,ZPC(BLK),SWRCH18A,B TITE	2
6003-000269	OPE-DUMMY	SCREW-TAPTYPE;BH,+,-,S,M3,L6,ZPC(WHT),SWRCH18A,-	2
6003-000196	OPE	SCREW-TAPTYPE;PWH,+,B,M3,L10,NI PLT,SWRCH18A	2
6003-000196	COVER,FUSER-EXIT	SCREW-TAPTYPE;PWH,+,B,M3,L10,NI PLT,SWRCH18A	2
6003-000282	GND	SCREW-TAPTYPE;BH,+,-,B,M3,L8,ZPC(BLK),SWRCH18A,-	1
6003-000196	OPE	SCREW-TAPTYPE;PWH,+,B,M3,L10,NI PLT,SWRCH18A	4
6003-000269	MEA BRACKET-REAR	SCREW-TAPTYPE;BH,+,-,S,M3,L6,ZPC(WHT),SWRCH18A,-	2
6003-000196	COVER-FRONT	SCREW-TAPTYPE;PWH,+,B,M3,L10,NI PLT,SWRCH18A	24
6003-000264	COVER-MP	SCREW-TAPTYPE;PWH,+,-,B,M3,L6,ZPC(WHT),SWRCH18A,-	1
6003-000282	ELA UNIT-LSU	SCREW-TAPTYPE;BH,+,-,B,M3,L8,ZPC(BLK),SWRCH18A,-	20
6003-000282	ELA UNIT-LD	SCREW-TAPTYPE;BH,+,-,B,M3,L8,ZPC(BLK),SWRCH18A,-	2
6003-000282	MEA UNIT-FRAME	SCREW-TAPTYPE;BH,+,-,B,M3,L8,ZPC(BLK),SWRCH18A,-	4
6002-000440	CASSETTE	SCREW-TAPPING;PWH,+,2,M3,L8,ZPC(BLK),SWRCH18A	2
6003-000196	CASSETTE	SCREW-TAPTYPE;PWH,+,B,M3,L10,NI PLT,SWRCH18A	14
6002-000440	CASSETTE-PAPER PATH	SCREW-TAPPING;PWH,+,2,M3,L8,ZPC(BLK),SWRCH18A	5
6003-000196	MEA-GUIDE PAPER DUP	SCREW-TAPTYPE;PWH,+,B,M3,L10,NI PLT,SWRCH18A	2
6003-000196	CASSETTE-COVER	SCREW-TAPTYPE;PWH,+,B,M3,L10,NI PLT,SWRCH18A	2
6002-000440	MEA-EXTENTION	SCREW-TAPPING;PWH,+,2,M3,L8,ZPC(BLK),SWRCH18A	2
6003-000196	ELA UNIT-FUSER	SCREW-TAPTYPE;PWH,+,B,M3,L10,NI PLT,SWRCH18A	24
6003-000269	ELA UNIT-FUSER	SCREW-TAPTYPE;BH,+,-,S,M3,L6,ZPC(WHT),SWRCH18A,-	10
6003-000282	ELA UNIT-FUSER	SCREW-TAPTYPE;BH,+,-,B,M3,L8,ZPC(BLK),SWRCH18A,-	2
6006-001193	ELA UNIT-FUSER	SCREW-MACHINE;PH,+,WSP,M3,L10,ZPC(WHT),SWRCH18A	2
6003-000196	CARTRIDGE-TRANSFER	SCREW-TAPTYPE;PWH,+,B,M3,L10,NI PLT,SWRCH18A	13
6003-000282	CARTRIDGE-TRANSFER	SCREW-TAPTYPE;BH,+,-,B,M3,L8,ZPC(BLK),SWRCH18A,-	19
6003-000196	BRKT-HINGE L	SCREW-TAPTYPE;PWH,+,B,M3,L10,NI PLT,SWRCH18A	1
6003-000196	BRKT-HINGE R	SCREW-TAPTYPE;PWH,+,B,M3,L10,NI PLT,SWRCH18A	1
6003-000196	COVER-L/R	SCREW-TAPTYPE;PWH,+,B,M3,L10,NI PLT,SWRCH18A	2
6003-000196	COVER-TOP,L/R	SCREW-TAPTYPE;PWH,+,B,M3,L10,NI PLT,SWRCH18A	2
6003-000196	FRAME-DAMPER L	SCREW-TAPTYPE;PWH,+,B,M3,L10,NI PLT,SWRCH18A	2
6003-000196	FRAME-DAMPER R	SCREW-TAPTYPE;PWH,+,B,M3,L10,NI PLT,SWRCH18A	2

Part Code	Location	Description	Qty
6003-000196	FRAME-DUCT	SCREW-TAPTYPE;PWH,+ ,B,M3,L10,NI PLT,SWRCH18A	2
6003-000196	FUSER	SCREW-TAPTYPE;PWH,+ ,B,M3,L10,NI PLT,SWRCH18A	4
6003-000196	HVPS	SCREW-TAPTYPE;PWH,+ ,B,M3,L10,NI PLT,SWRCH18A	6
6003-000269	AC-BOARD	SCREW-TAPTYPE;BH,+ ,-,S,M3,L6,ZPC(WHT),SWRCH18A,-	6
6003-000269	BRKT-MAIN	SCREW-TAPTYPE;BH,+ ,-,S,M3,L6,ZPC(WHT),SWRCH18A,-	8
6003-000269	BRKT-REAR	SCREW-TAPTYPE;BH,+ ,-,S,M3,L6,ZPC(WHT),SWRCH18A,-	7
6003-000269	COVER-TOP	SCREW-TAPTYPE;BH,+ ,-,S,M3,L6,ZPC(WHT),SWRCH18A,-	6
6003-000269	COVER-TOP,BRKT-REAR	SCREW-TAPTYPE;BH,+ ,-,S,M3,L6,ZPC(WHT),SWRCH18A,-	4
6003-000269	FDB	SCREW-TAPTYPE;BH,+ ,-,S,M3,L6,ZPC(WHT),SWRCH18A,-	4
6003-000269	LSU	SCREW-TAPTYPE;BH,+ ,-,S,M3,L6,ZPC(WHT),SWRCH18A,-	4
6003-000269	MAIN PBA	SCREW-TAPTYPE;BH,+ ,-,S,M3,L6,ZPC(WHT),SWRCH18A,-	4
6003-000269	SMPS	SCREW-TAPTYPE;BH,+ ,-,S,M3,L6,ZPC(WHT),SWRCH18A,-	4
6003-000269	BRKT-DUMMY POWER	SCREW-TAPTYPE;BH,+ ,-,S,M3,L6,ZPC(WHT),SWRCH18A,-	2
6003-000269	GUIDE-HARNESS	SCREW-TAPTYPE;BH,+ ,-,S,M3,L6,ZPC(WHT),SWRCH18A,-	4
6003-000301	ELA UNIT-BRACKET_MAIN	SCREW-TAPTYPE;BH,+ ,S,M4,L6,ZPC(WHT),SWRCH18A	1

### 3.3. Replacing a maintenance parts

---

To avoid print quality and paper feed problems resulting from worn parts and to maintain your machine in top working condition, the following parts will need to be replaced after printing the specified number of pages or when the life span of each item has expired.

 **NOTE**

Turn power off and unplug power cord from the wall outlet before any servicing.

#### 3.3.1. Fuser Unit

---

1. Open the Top cover. Remove 4 screws.



 **CAUTION**

The fuser unit is very hot. So turn the printer off and wait until the fuser unit to cool before replacing it.

2. Lift up and release the fuser unit while pushing both levers.

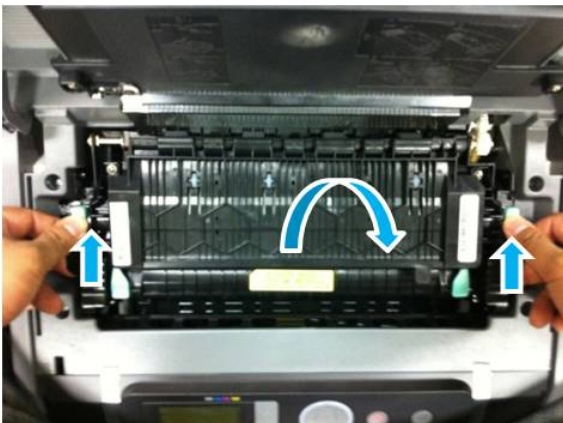

### 3.3.2. Pick-Up roller

1. Remove the Cassette Unit.



2. Pull the pick up roller in the direction of the arrow.

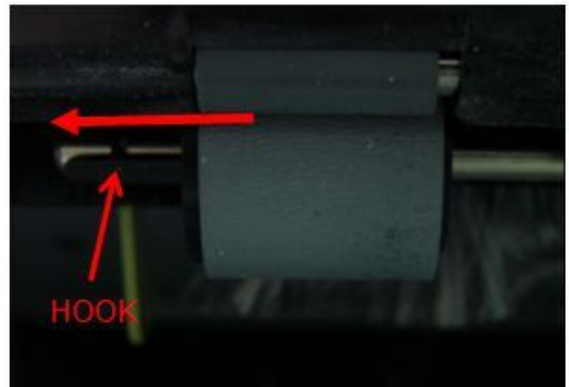

### 3.3.3. Retard Roller

1. Remove the cassette.



2. Remove the Cassette-Paper-Path after removing 2 screws.

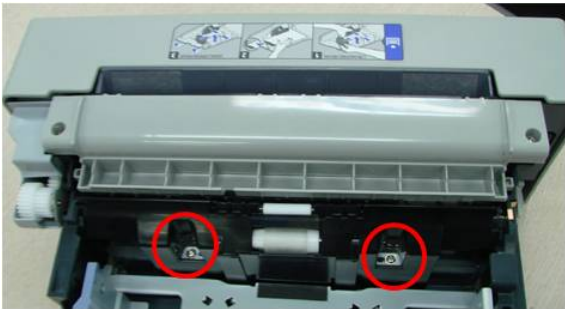

3. Remove the Plate-Path after removing 5 screws.



4. Remove the Guide-Paper Path after releasing both hooks.



5. Release the Retard roller holder.

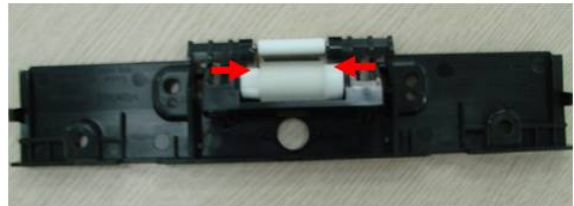

6. Release the Retard roller from its holder.





### 3.3.4. Dust Cleaning Kit

1. Remove the cassette.



2. Open the front cover. Remove the PTB (Paper Transfer Belt) unit.



3. Pull the toner cartridge unit out of the machine.

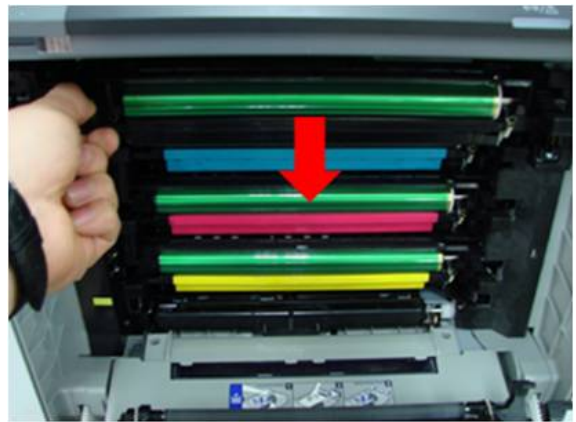

4. Separate the guide-pick up.



5. Separate the dust cleaning kit.



### 3.4. Disassembly Procedure

#### 3.4.1. Cover

Before disassembling the cover unit, remove all toner cartridges.

1. Remove 2 screws and the MEA COVER-NOISE.



2. Open the front cover. And remove 2 screws.



3. Remove the left/right cover by pushing the hooks with any sharp tool.



4. Unlatch the 5 hooks from the bottom before remove the side cover. And remove the right/left cover.

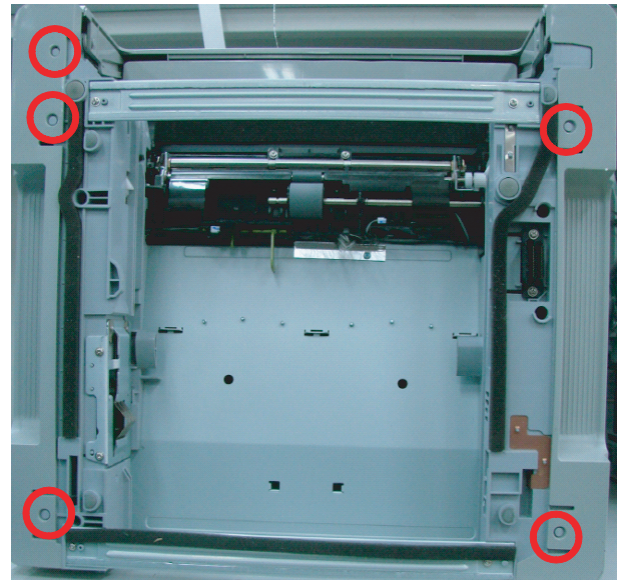

5. Release the rear cover after remove 7 screws.



6. Remove 4 screws from both side.

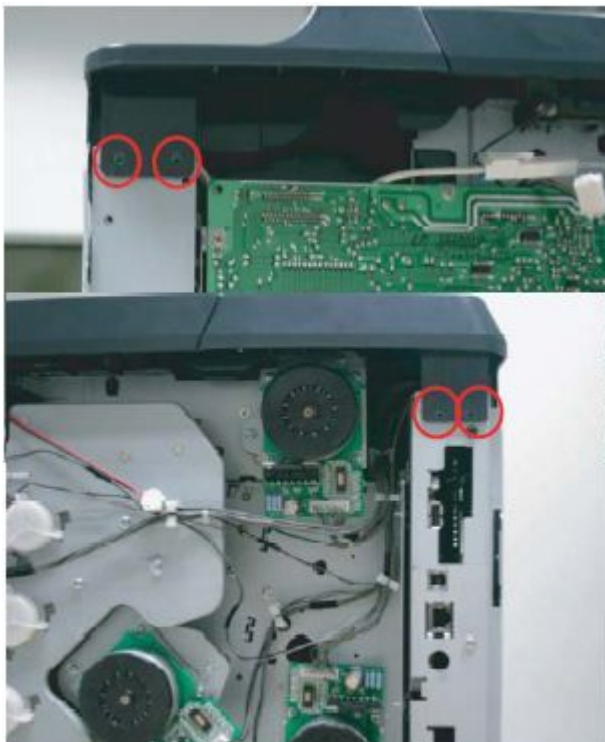

7. Remove 6 screws.

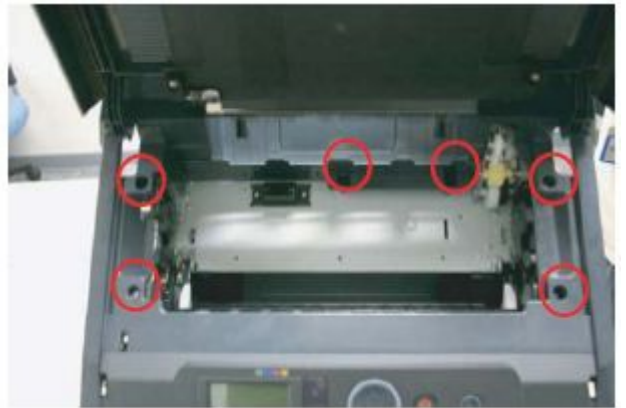

8. Lift the top cover up. Unplug 2 connectors.

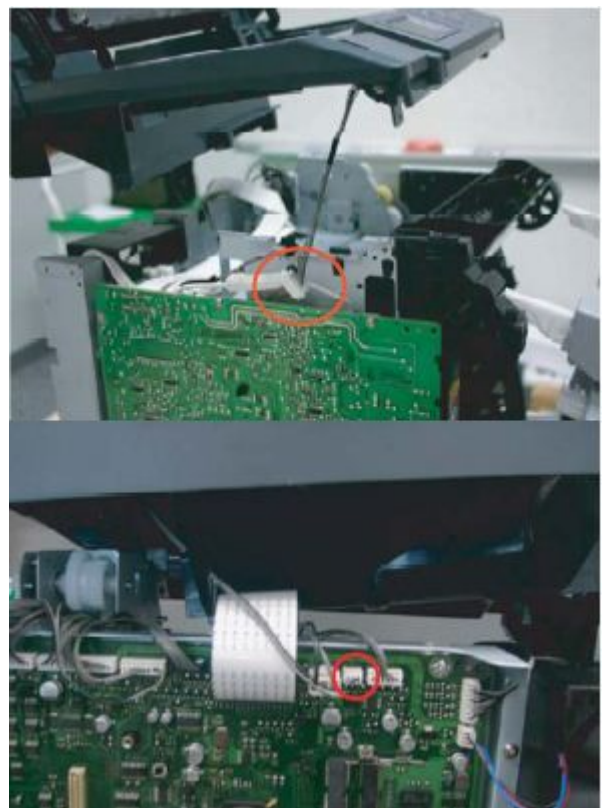

9. Remove the left/right link.

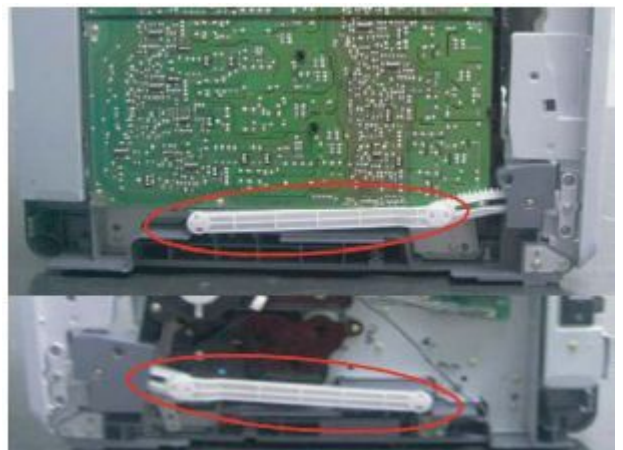

10. Remove 4 screws from both side.

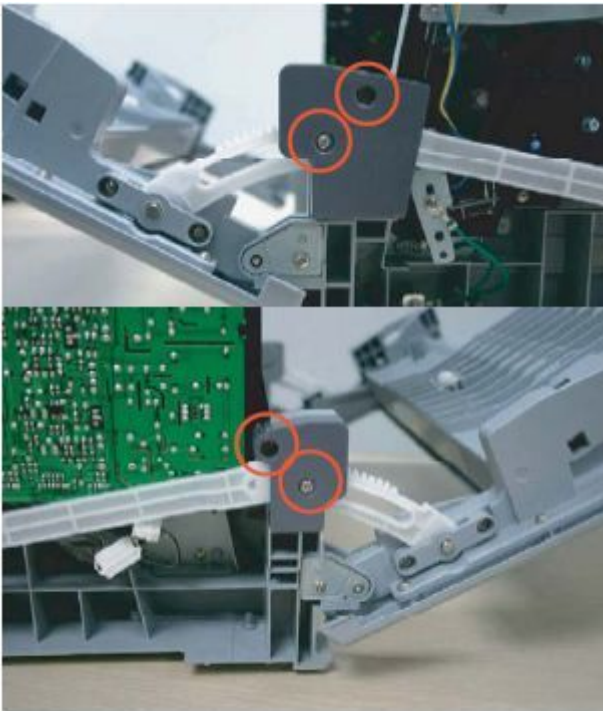

12. Remove the Damper hinge. (2 EA) And release the front cover.

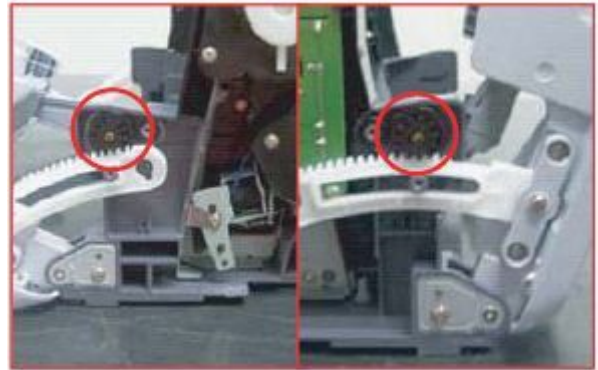

11. Remove the Bracket hinge with any tool after remove one screw.

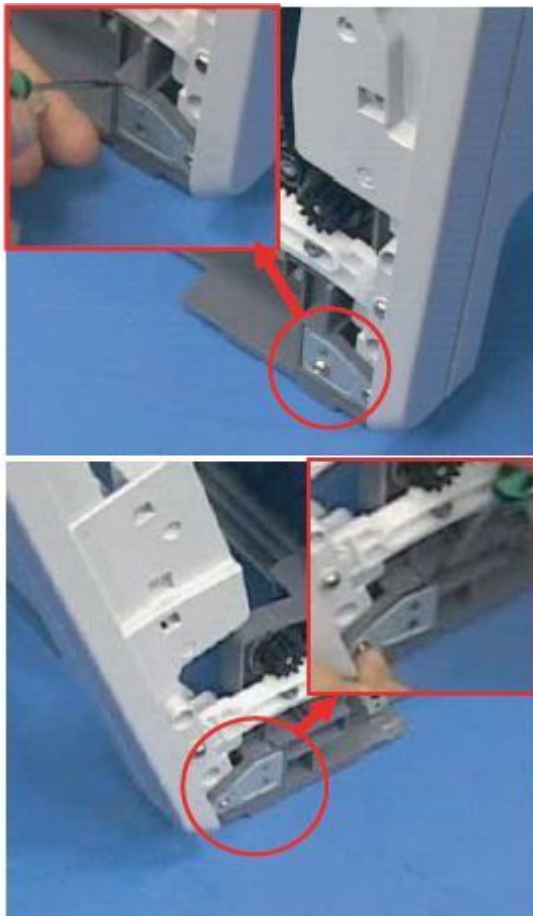

### 3.4.2. Front Cover

The following method describes how to disassemble the front cover without removing both side cover.

1. Open the Front Cover. Remove 2 screws. And remove the shaft.



#### NOTE

When reassembling, be careful the shaft head direction.

2. For the opposite side, remove 2 screws and the shaft.



#### NOTE

When reassembling, be careful the shaft head direction.

3. Remove 6 screws from both side.

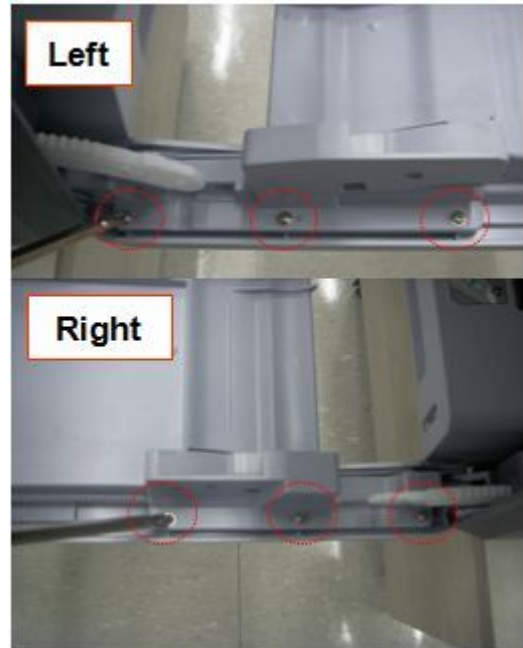

4. Release the Front cover unit.



### 3.4.3. OPE Unit

---

Before disassembling the OPE unit, remove the Top cover.

1. Remove 2 screws from both side.



2. Release the OPE PBA after removing 4 screws.

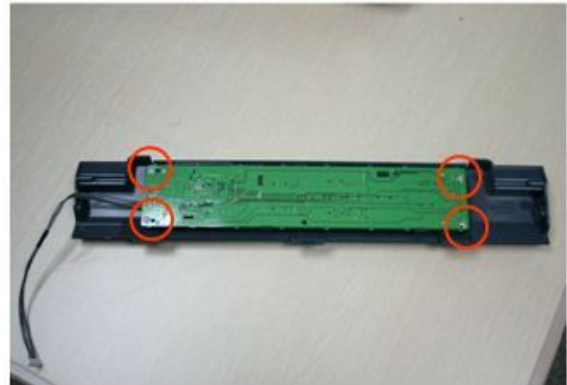

### 3.4.4. Main PBA

---

Before disassembling the Main PBA, remove the cover unit.

1. Unplug all harness from Main PBA.

2. Remove 4 screws and release the Main PBA.



**CAUTION**

Observe precautions For handling Electrostatic Sensitive Devices

### 3.4.5. HVPS board

Before disassembling the HVPS board, remove the cover unit.

1. Unplug the harness from the top/bottom of the HVPS Board.

2. Remove 8 screws and unlatch 4 hooks.

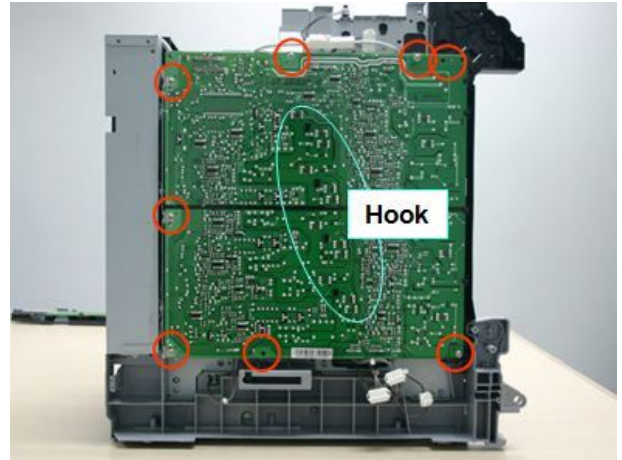

### 3.4.6. SMPS Board

Before disassembling the SMPS board, remove the cover unit.

1. Unplug the harness from the SMPS board.

2. Release the SMPS board after removing 4 screws.

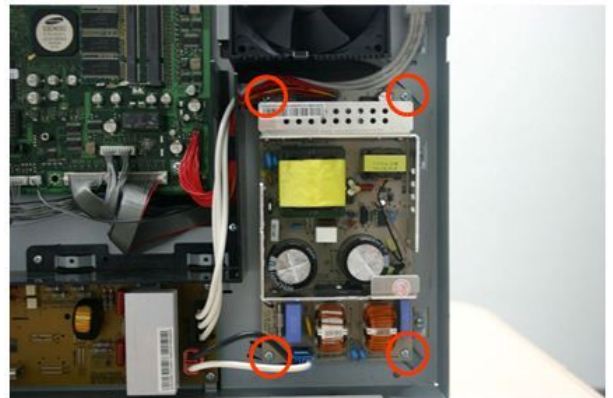

### 3.4.7. HVPS Sub Board (AC Board)

Before disassembling the AC board, remove the Main PBA.

1. Remove the 4 screws.



2. Remove the SMPS board after removing 4 screws.



3. Remove the 3 screws. And then remove the SMPS bracket.

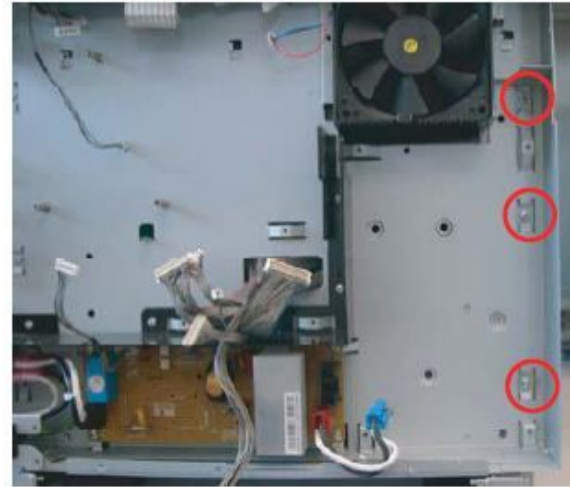

4. Remove 6 screws and release the AC Board and Insulation sheet.

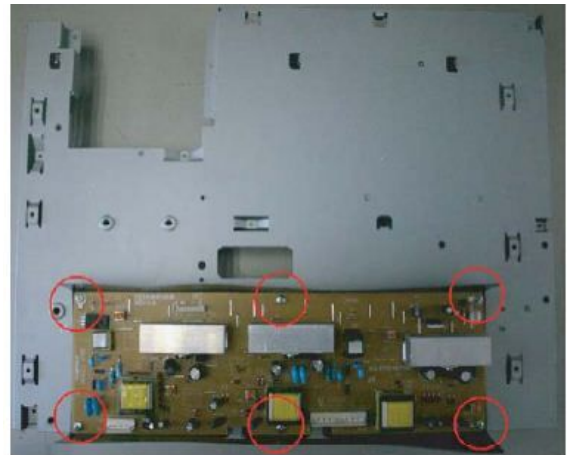



### 3.4.8. Fuser Control Board

Before disassembling the Fuser control board, remove the cover unit.

1. Unplug the harness from the Fuser control board.

2. Release the Fuser control board after removing 4 screws.

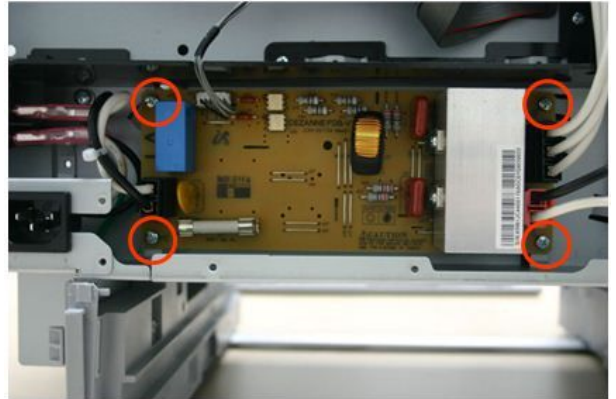

### 3.4.9. LSU

---

Before disassembling the LSU, remove the BRACKET-REAR.

1. Remove the BRACKET-REAR after removing 7 screws.



2. Remove the rear-fan. Remove 4 screws. And remove the LSU.

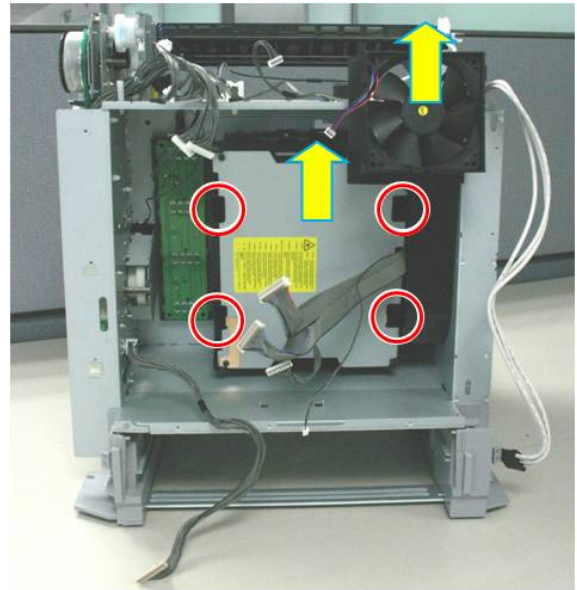

### 3.4.10. Clutch Pick-Up and Clutch-Feed

1. Remove 2 E-rings.

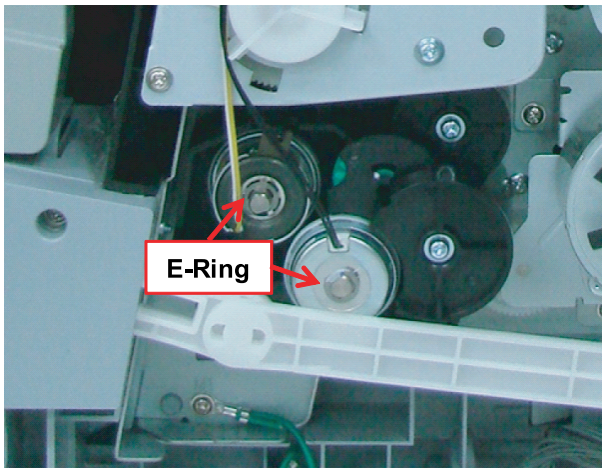

2. Release the Clutch-Feed and Clutch Pick-Up.

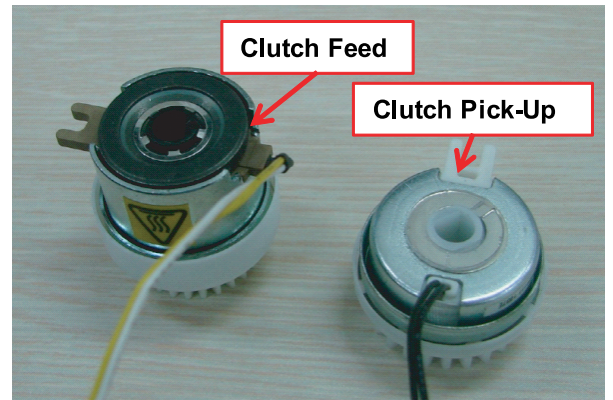

# 4. Alignment and Troubleshooting

## 4.1. Alignment and Adjustments

This chapter describes the main functions for service, such as the product maintenance method, the test output related to maintenance and repair, Jam removing method, and so on.

It includes the contents of manual.

### 4.1.1. Control Panel

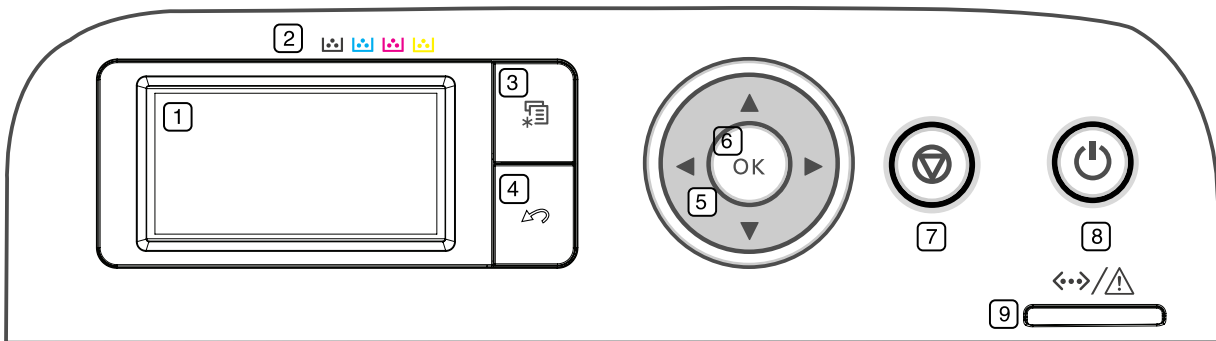

1	<b>Display</b>	Shows the current status and prompts during an operation.
2	<b>Toner Colors</b>	Show the status of each toner cartridge.
3	<b>Menu</b>	Enters menu mode and scrolls through the available menus.
4	<b>Back</b>	Sends you back to the upper menu level.
5	<b>Arrow</b>	Scroll through the options available in the selected menu, and increase or decrease values.
6	<b>OK</b>	Confirms the selection on the screen.
7	<b>Stop</b>	Stops an operation at any time. The pop-up window appears on the screen showing the current job that the user can stop or resume.
8	<b>Power</b>	Sends the machine into power saver mode. You can also turn the power on and off with this button.
9	<b>Status LED</b>	Shows the status of your machine.

## 4.1.2. Understanding The Status LED

The color of the Status LED indicates the machine's current status.

STATUS		DESCRIPTION
Off		<ul style="list-style-type: none"> <li>The machine is off-line.</li> <li>The machine is in power saver mode. When data is received, or any button is pressed, it switches to on-line automatically.</li> </ul>
Green	On	<ul style="list-style-type: none"> <li>The machine is powered on and can be used.</li> </ul>
	Blinking	<ul style="list-style-type: none"> <li>When the LED blinks slowly, the machine is receiving data from the computer.</li> <li>When the LED blinks rapidly, the machine is printing data.</li> </ul>
Red	On	<ul style="list-style-type: none"> <li>The toner cartridge is totally empty. Remove the old toner cartridge and install a new one.</li> <li>A paper jam has occurred.</li> <li>The cover is opened. Close the cover.</li> <li>There is no paper in the tray. Load paper in the tray.</li> <li>The machine has stopped due to a major error. Check the display message.</li> </ul>
	Blinking	<ul style="list-style-type: none"> <li>A minor error has occurred and the machine is waiting for the error to be cleared. Check the display message. When the problem is cleared, the machine resumes.</li> <li>The toner cartridge is near the end of its life. Order a new toner cartridge. You can temporarily improve print quality by redistributing the toner.</li> </ul>

- Estimated cartridge life means the expected or estimated toner cartridge life, which indicates the average capacity of print-outs and is designed pursuant to ISO/IEC 19798. The number of pages may be affected by operating environment, percentage of image area, printing interval, media type, and media size. Some amount of toner may remain in the cartridge even when red LED is on and the printer stops printing.

### 4.1.3. JAM Removal

---

If a paper jam occurs an error message appears in the LCD display. Find and remove the jammed paper. If you don't see the paper, open the covers. Do not use a tweezers, pincers or other metal tools when clearing a paper jam. This could damage the internal mechanism causing print quality problems or possibly electrical shock.

#### 4.1.3.1. Clearing Paper Jams

---

##### In tray

If paper is jammed in the paper feed area, follow the next steps to release the jammed paper.

1) Using the handle, completely open the front cover.

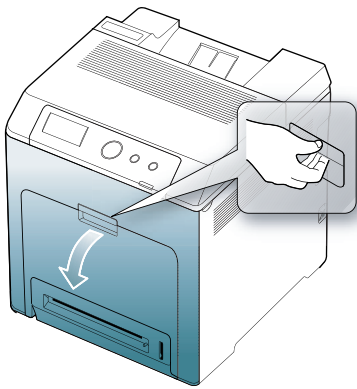

4) Pull out tray 1.

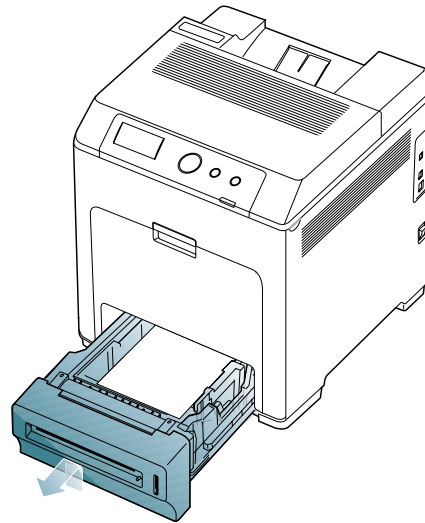

2) Carefully remove the paper by pulling in the direction as shown below.

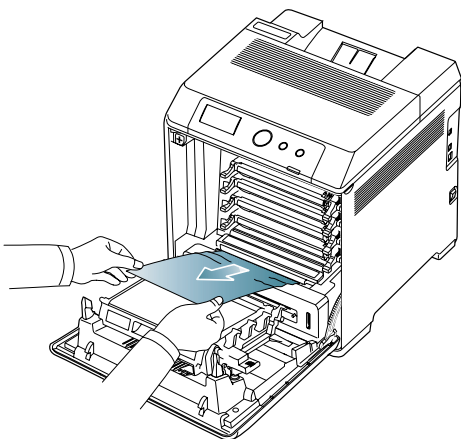

5) Remove the jammed paper by gently pulling it straight out as shown below.

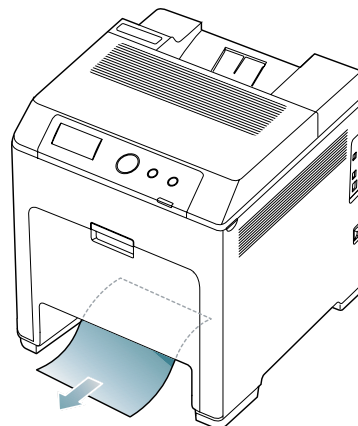

3) Close the front cover.

6) Insert tray 1 back into the machine until it snaps into place. Printing automatically resumes.

### In optional trays

- 1) Pull out optional tray 2 open.
- 2) Remove the jammed paper from the machine.
- 3) Open the front cover.
- 4) Pull the jammed paper out in the direction shown. To avoid tearing the paper, pull it out gently and slowly.

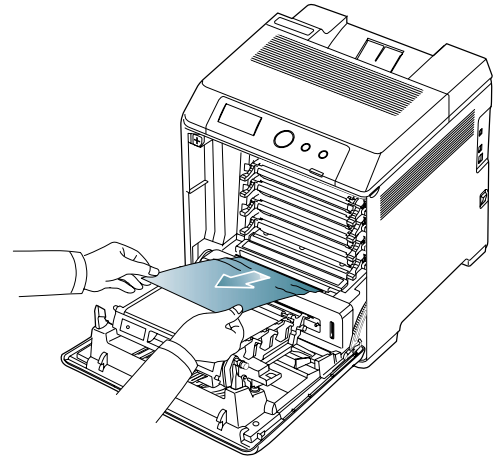
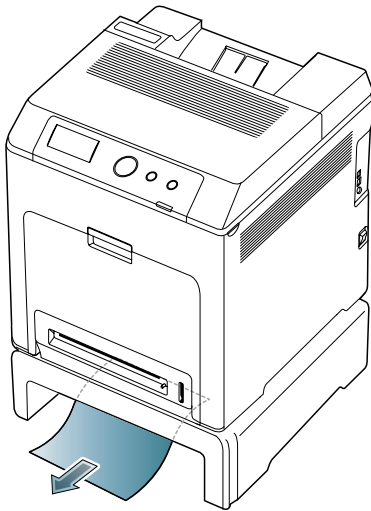

If the paper does not move when you pull or if you do not see the paper in this area, stop and go to the next step.

### In the multi-purpose tray

- 1) If the paper is not feeding properly, pull the paper out of the machine.
- 4) Remove the jammed paper by pulling in the direction shown. To avoid tearing the paper, pull it out gently and slowly.

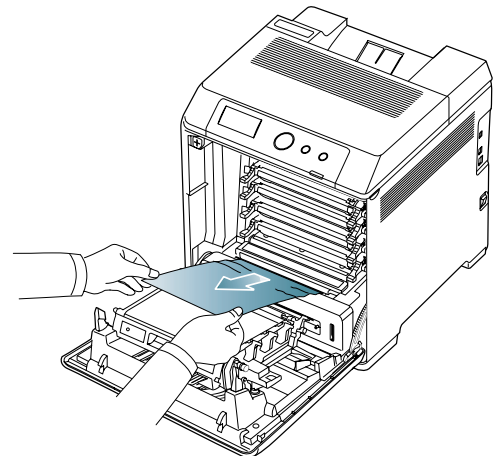
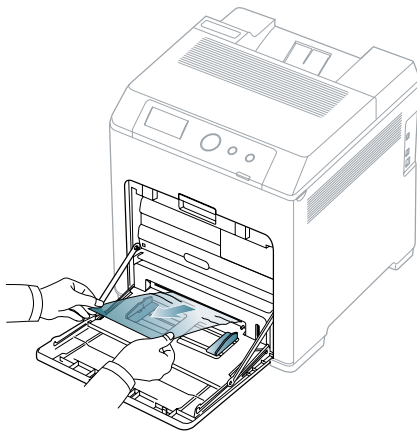

If you do not see the jammed paper or if there is any resistance when you pull, stop and go to step 3.

- 2) Open and close the front cover to resume printing.
- 3) Using the handle, completely open the front cover.
- 5) Close the front cover to resume printing.

### In the fuser unit area

- 1) Open the top cover.

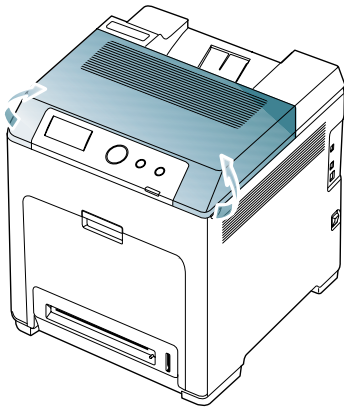

- 3) Pull up the paper jam lever to remove pressure from the Fuser Rollers and carefully take the jammed paper out of the machine.

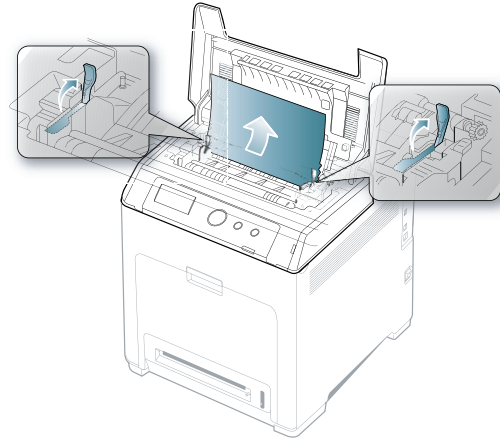

- 2) Open the inner cover using the handle.

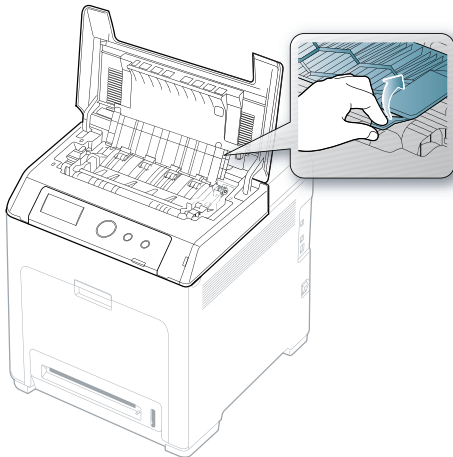

- 4) Press down the paper jam lever to reapply pressure to the Fuser Rollers.
- 5) Close the inner cover.
- 6) After removing the jammed paper, check for paper which may be jammed in other parts of the machine.
- 7) Close the top cover. Ensure that the cover is securely closed.

### In exit area

- 1) Open and close the front cover. The jammed paper is automatically ejected from the machine.

- 2) Gently pull the paper out of the output tray.

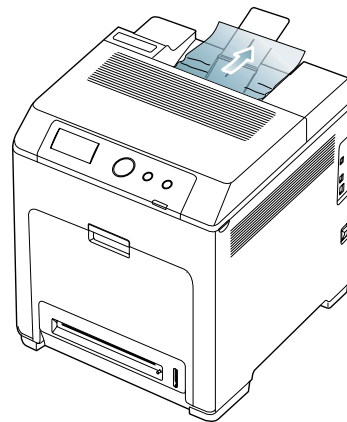

If you do not see the jammed paper or if there is any resistance when you pull, stop and see “In the fuser unit area” section

- 3) Open and close the front cover to resume printing.



**In the duplex unit area**

- 1) Using the handle, completely open the front cover.

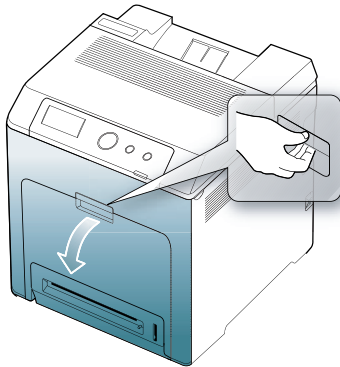

- 2) Press the green release handle to release the paper transfer belt. Holding the handle on the paper transfer belt, lift it out of the machine.

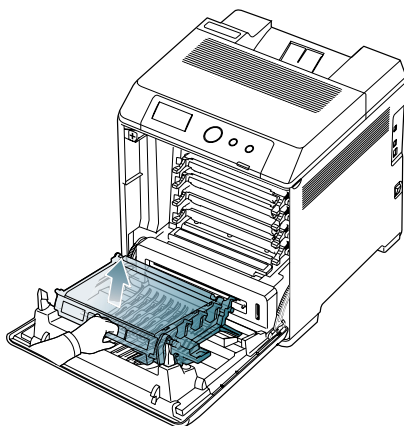

- 3) Remove the jammed paper by pulling in the direction shown. To avoid tearing the paper, pull it out gently and slowly.

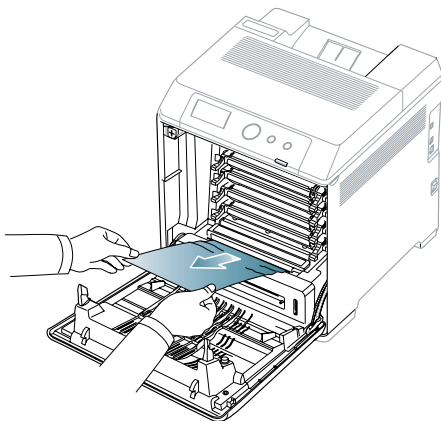

- 4) Holding the handle on the paper transfer belt, align it with the slots on the inside of the front cover.

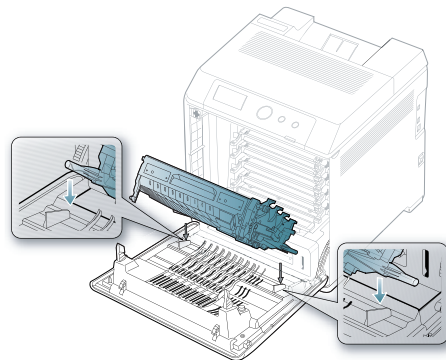

- 5) Lower the paper transfer belt until it is parallel with the front cover and firmly seated.

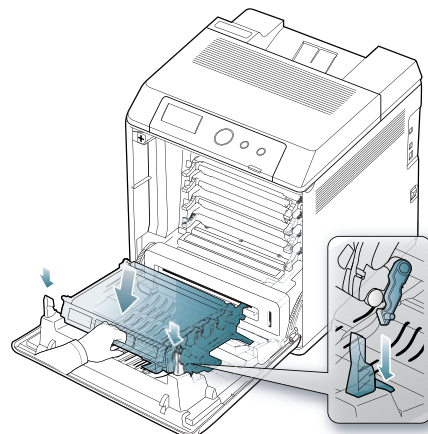

- 6) Close the front cover to resume printing.

#### 4.1.4. Useful menu item for service

---

##### Printing a machine report

You can print the machine's information.

- Configuration : You can print a report on the machine's overall configuration.
- Demo Page : You can print the demo page whether your machine is printing properly or not.

- 1) Press "Menu" Button on the control panel.
- 2) Press up/down arrow to highlight Information and press OK.
- 3) Press up/down arrow to highlight Configuration and press OK.
- 4) The display shows Print?, then press OK to print the configuration report.

##### Monitoring the supplies life

To view the supply life indicators, follow the steps below:

- 1) Press "Menu" Button on the control panel.
- 2) Press up/down arrow to highlight System Setup and press OK.
- 3) Press up/down arrow to highlight Maintenance and press OK.
- 4) Press up/down arrow to highlight Supplies Info. and press OK.
- 5) The display shows two options as you press up/down arrow.
  - Printed Pages: Displays the total number of pages printed.
  - Remains Info.: Displays how much toner remains in the cartridge.

##### Cleaning a fuser belt

If you are experiencing blurred, faded, or smeared printouts, you can clear the problem by printing a cleaning sheet, provided by your printer.

- 1) Press "Menu" Button on the control panel.
- 2) Press up/down arrow to highlight System Setup and press OK.
- 3) Press up/down arrow to highlight Maintenance and press OK.
- 4) Press up/down arrow to highlight Clean Fuser and press OK. Your machine automatically picks up a sheet of paper from the tray and prints out a cleaning sheet with dust or toner particles on it.

##### Conducting the Auto Color Registration

You can adjust the position of color texts or graphics to match the position of the printed colors to those on your screen. When you have moved the machine or replaced some parts, it is strongly recommended to operate this menu manually.

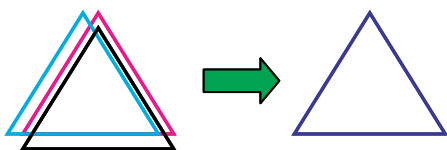

- 1) Press "Menu" Button on the control panel.
- 2) Press up/down arrow to highlight Color and press OK.

- 3) Press up/down arrow to highlight Auto Color Reg. and press OK.
- 4) The display shows Run Now? ◀Yes▶/ ▶No▶ , then select yes or no. And press the OK to conduct the Auto Color Registration.

#### 4.1.5. Periodic Defective Image

If a mark or other printing defects occur at regular intervals down on the page, they may be caused by damaged or contaminated rollers. Use the table below to find which roller causes the defect from the periods of the rollers. If the roller is dirty, try to clean it. If the problem still remains after cleaning, replace the part including the defective roller.

Roller	Period (mm)	Phenomenon	Defective part
Fuser Belt	125.7 mm	Waving, Offset, Spot, Line Burst	Fuser Unit
Pressure Roller	91 mm	Offset, Spot, Line Burst	Fuser Unit
OPC Drum	75.39 mm	White and Black Spot, Periodic Banding, Ghost, Color Registration	Corresponding toner cartridge
Deve Roller (CMY)	36.1 mm	White Spot, Horizontal Band	Corresponding toner cartridge
Deve Roller (K)	35.5 mm	White Spot, Horizontal Band	Corresponding toner cartridge
Supply Roller (CMY)	48.2 mm	Offset, Spot, Line Burst	Corresponding toner cartridge
Supply roller (K)	47.4 mm	Offset, Spot, Line Burst	Corresponding toner cartridge
Transfer Roller	44 mm	Periodic Band (by little difference of density)	Paper Transfer Belt unit
PTB charge roller	31.4 mm	White and Black Spot, Periodic Banding	Paper Transfer Belt unit

### 4.1.6. Useful management tools

#### 4.1.6.1. Using Samsung Easy Printer Manager (Windows only)

Samsung Easy Printer Manager is a Windows-based application that combines Samsung machine settings into one location. Samsung Easy Printer Manager combines device settings as well as printing environments, settings/actions and launching. All of these features provide a gateway to conveniently use your Samsung machine. Samsung Easy Printer Manager provides two different user interfaces for the user to choose from: the basic user interface and the advanced user interface. Switching between the two interfaces is easy: just click a button.



**NOTE**

Internet Explorer 6.0 or higher is the minimum requirement for Samsung Easy Printer Manager.

#### Understanding Samsung Easy Printer Manager

To open the program:

Select Start>Programs or All Programs>Samsung Printers>Samsung Easy Printer Manager>Samsung Easy Printer Manager.

The Samsung Easy Printer Manager interface is comprised of various basic sections as described in the table that follows:

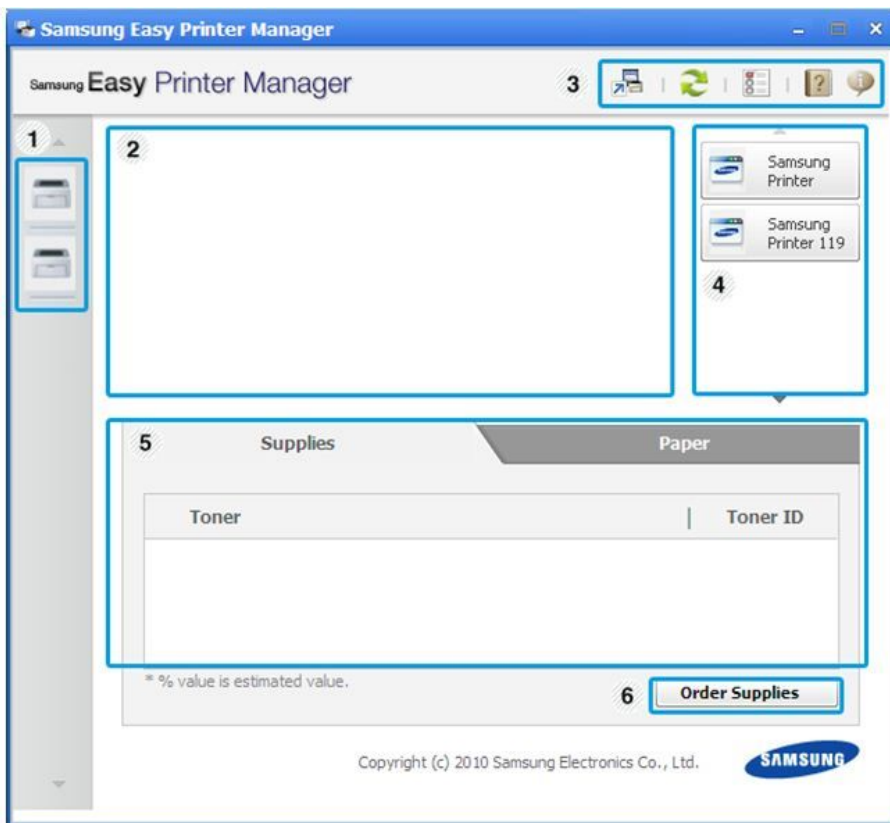

No	Area	Description
1	Printer List	The printer list displays the installed printer icons on your computer.
2	Printer Information	<p>This area gives you general information about your machine. You can check information, such as the machine's model name, IP address (or Port name), and machine status.</p> <div style="background-color: #e0e0e0; padding: 5px;">  <b>NOTE</b>            User's Guide button : This button opens Troubleshooting Guide when an error occurs. You can directly open the necessary section in the user's guide.         </div>
3	Application Information	Includes links for changing to the advanced settings, preference, help, and about.
4	Quick links	Displays Quick links to machine specific functions. This section also includes links to applications in the advanced settings.
5	Contents Area	Displays information about the selected machine, remaining toner level, and paper. The information will vary based on the machine selected. Some machines do not have this feature.
6	Order Supplies	Click on the Order button from the supply ordering window. You can order replacement toner cartridge(s) from online.

### Advanced settings user interface overview

The advanced user interface is intended to be used by the person responsible for managing the network and machines.

- **Device Settings**

You can configure various machine settings such as machine setup, paper, layout, emulation, network, and print information.

- **Alert Settings**

This is menu includes settings related to error alerting.

- **Printer Alert** : Provides settings related to when alerts will be received.
- **Email Alert** : Provides options relating to receiving alerts via email.
- **History Alert** : Provides a history of device and toner related alerts.

- **Job Accounting**

Provides querying of quota information of the specified job accounting user. This quota information can be created and applied to devices by job accounting software such as SyncThru™ or CounThru™ admin software.

#### 4.1.6.2. Using Samsung Printer Status (Windows only)

[The Samsung Printer Status is a program that monitors and informs you of the machine status.]

**NOTE**

- The Samsung Printer Status window and its contents shown in this user’s guide may differ depending on the machine or operating system in use.
- Check the operating system(s) that are compatible with your machine (see Basic guide).

**Samsung Printer Status overview**

If an error occurs while operating, you can check the error from the Samsung Printer Status. Samsung Printer Status is installed automatically when you install the machine software.

You can also launch Samsung Printer Status manually. Go to the Printing Preferences , click the Basic tab > Printer Status button.

These icons appear on the Windows task bar:

Icon	Mean	Description
	Normal	The machine is in ready mode and experiencing no errors or warnings.
	Warning	The machine is in a state where a soft error has occurred. For example, a toner low status, which may lead to toner empty status.
	Error	The machine has at least one hard error, such as out of paper, fuser error, etc. Machine does not have ability to come to ready without customer intervention.

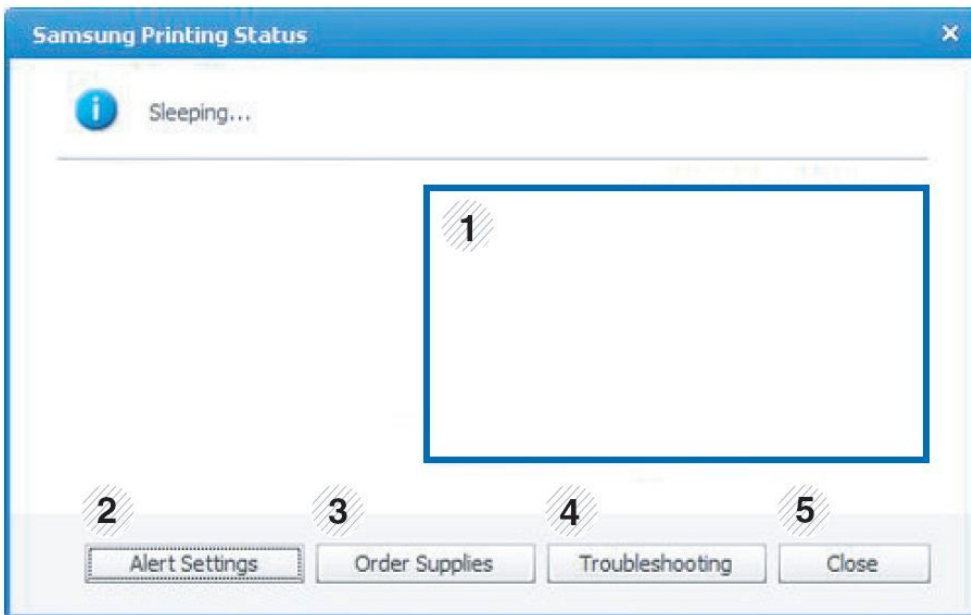

1	Toner Level	You can view the level of toner remaining in each toner cartridge. The machine and the number of toner cartridge(s) shown in the above window may differ depending on the machine in use. Some machines do not have this feature.
2	Alert Settings	Select the settings you want from the options window.
3	Order Supplies	You can order replacement toner cartridge(s) from online.
4	Troubleshooting	You can directly open the troubleshooting section in the user’s guide.
5	Close	Close the window.

### 4.1.6.3. Using Smart Panel (Macintosh and Linux only)



Smart Panel is a program that monitors and informs you of the machine's status, and allows you to customize the machine's settings. For Macintosh, Smart Panel is installed automatically when you install the machine software. For Linux, you can download Smart Panel from the Samsung website [www.samsung.com](http://www.samsung.com).

#### NOTE



- The Smart Panel window and its contents shown in this user's guide may differ depending on the machine or operating system in use.
- Check the operating system(s) that are compatible with this model.

### Smart Panel overview

If an error occurs while operating, you can check the error from the Smart Panel. You can also launch Smart Panel manually.

Macintosh		Click this icon the Smart Panel icon on the menu bar.
Linux		Double-click the Smart Panel icon in the Notification Area.



1	Toner Level	You can view the level of toner remaining in each toner cartridge. The machine and the number of toner cartridge(s) shown in the above window may differ depending on the machine in use. Some machines do not have this feature.
2	Buy Now	You can order replacement toner cartridge(s) from online.
3	User's Guide	You can view the online User's Guide.   <b>NOTE</b> This button opens the Troubleshooting Guide when an error occurs. You can directly open the troubleshooting section in the user's guide.
4	Printer Setting	You can configure various machine settings in the Printer Settings Utility window. Some machines do not have this feature.   <b>NOTE</b> If you connect your machine to a network, the SyncThru™ Web Service window appears instead of the Printer Settings Utility.

### **Changing Smart Panel's settings**

Right-click in Linux or in Mac OS X click on the Smart Panel icon and select Options. Select the settings you want from the Options window.



## 4.1.7. Updating Firmware

---

This chapter includes instructions for updating the printer firmware. You can update the printer firmware by using one of the following methods :

- Update the firmware by using the USB port.
- Update the firmware by using the Network.

### 4.1.7.1. Update the firmware by using the USB port

---

#### Upgrading preparations

- usblast2.exe : Tool which sends firmware data to printer.
- Firmware file to update.

#### Upgrade Procedure

- 1) Turn the machine off.
- 2) Connect USB cable to printer.
- 3) Turn the machine on. Check if the printer is the ready status.
- 4) Drag the firmware file and Drop down on the usblast2.exe.

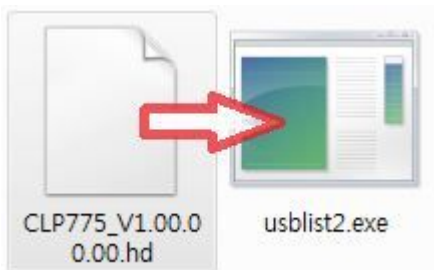

And then firmware update will be started automatically.

- 5) When upgrading is completed, machine is automatically re-booting.

### 4.1.7.2. Update the firmware by using the network

#### Upgrading preparations

- Wired or Wireless Network connection is established.
- Firmware file to update

#### Upgrade Procedure

1) Open the Web-browser and input IP address of machine. Click “Login”.

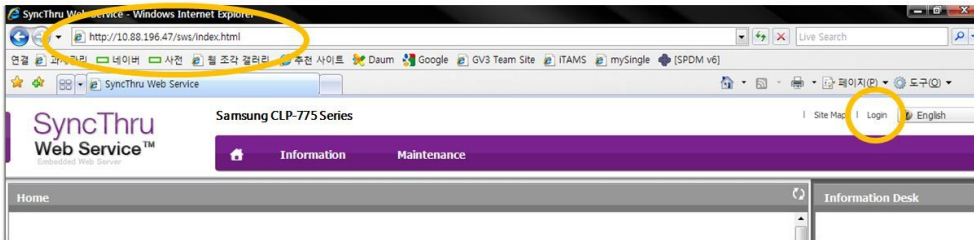

2) Log-in Admin Mode. (ID: admin, PW: sec00000)

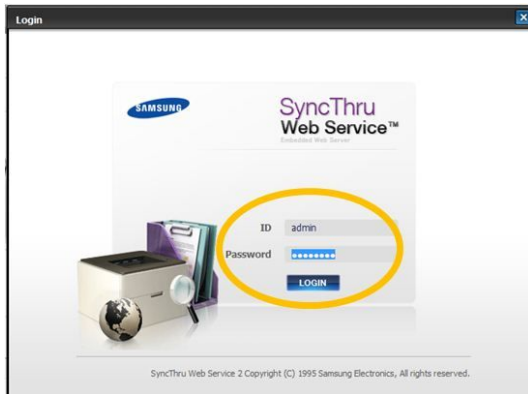

**CAUTION**  
Please, change SWS Default ID and Password for system security in case of your first connection

**NOTE**  
If the machine supports ‘Direct Print’, you can enable this function using the SWS menu. The default configuration is ‘Disabled’ for your security

3) Select Maintenance menu and click “upgrade wizard”

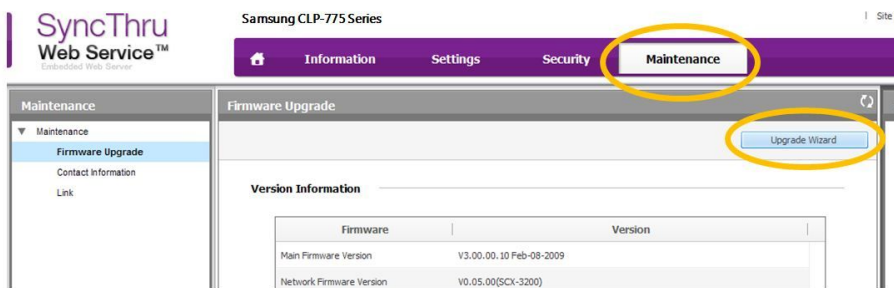

4) Select firmware file using “browser” button and press next button.

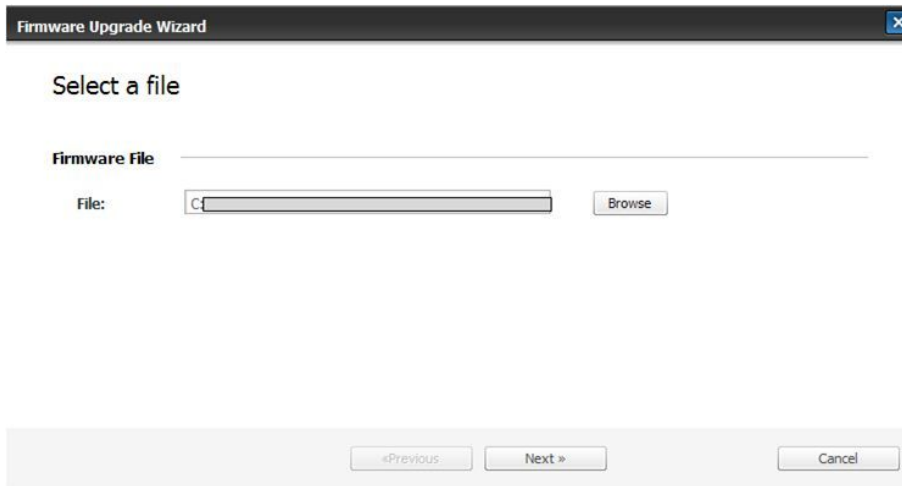

- 5) SyncThru will check verify firmware file and compare version and press next button.

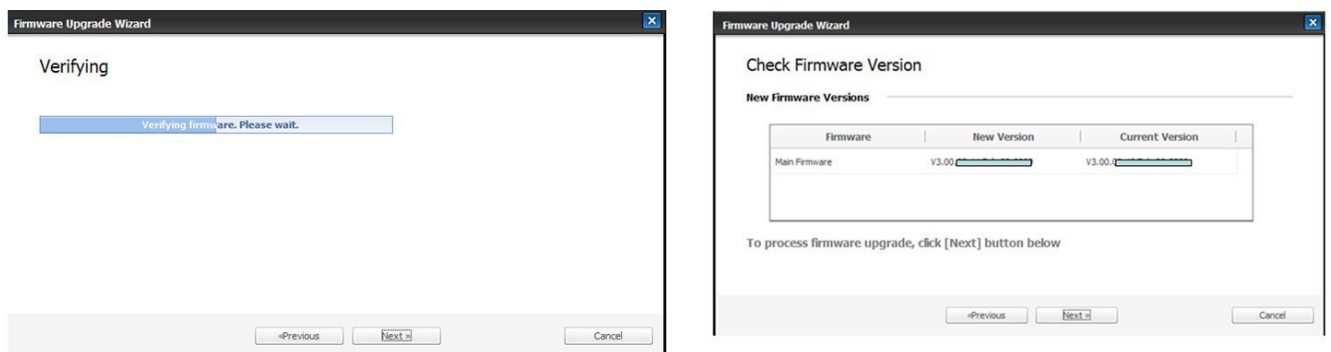

- 6) Machine starts upgrading. SyncThru will return home page after upgrading is completed.

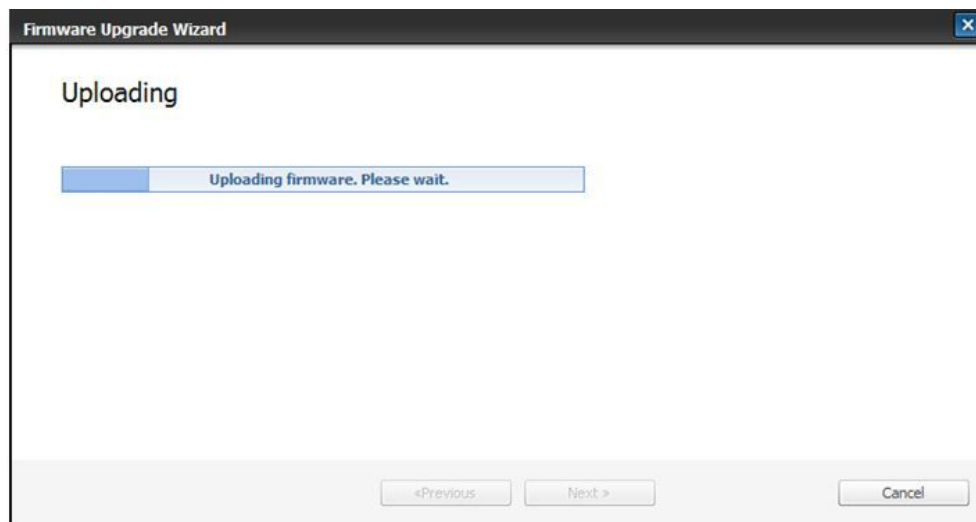

### 4.1.8. Tech Mode

In service (tech) mode, the technician can check the machine and perform various test to isolate the cause of a malfunction. While in Tech mode, the machine still performs all normal operations.

#### 4.1.8.1. To enter the Tech Mode

To enter the Tech Mode, press “ **Menu + Up + Left + OK + Right + Stop + Menu**” in sequence, and the LCD briefly displays ‘Tech Mode’, the machine has entered service tech mode.

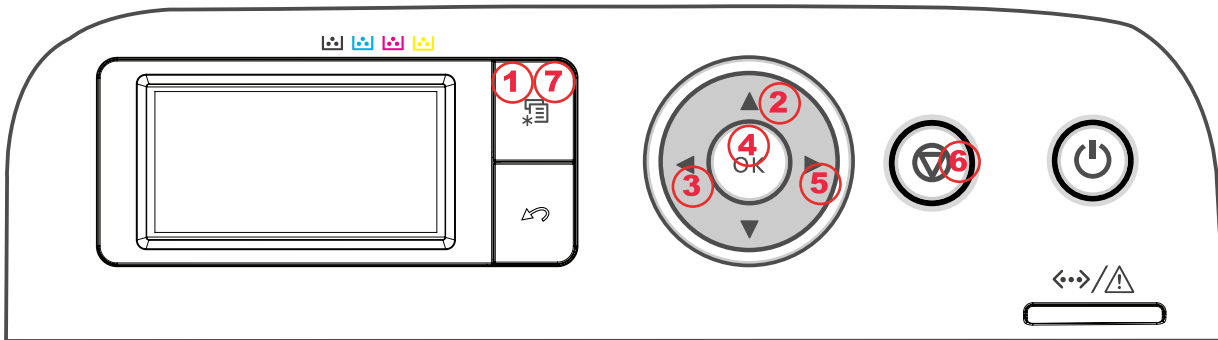

After entering the tech mode, select the item you want by using a button on control panel. Below picture shows to select the motor color opc item in Test Routine.

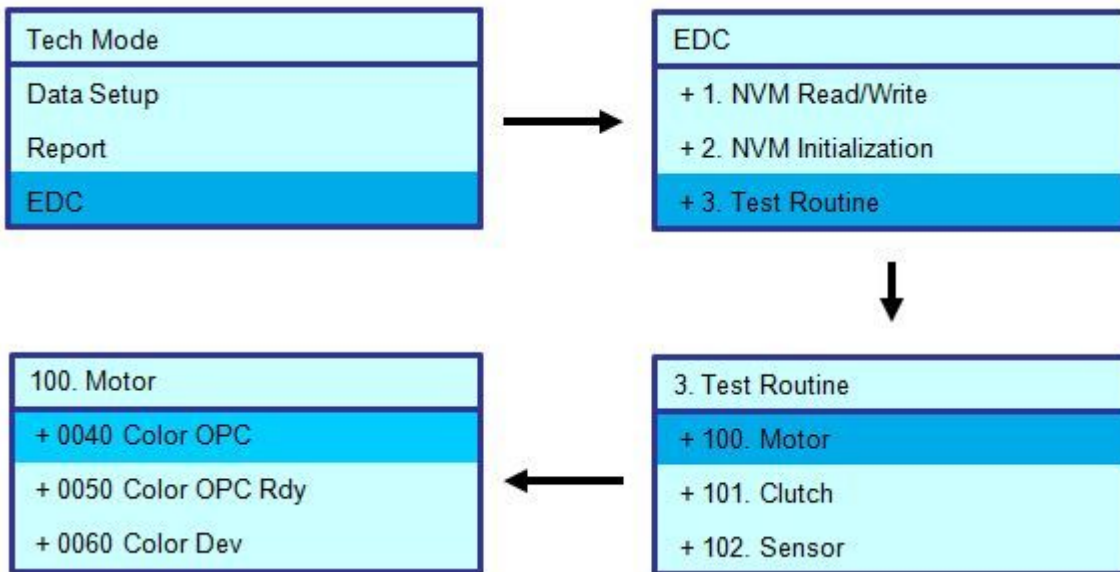

## 4.1.8.2. Tech Mode Menu Map

Depth 1	Depth 2	Depth 3	Depth 4
Data Setup	HDD Setup	Disk Format	Formatting...
		Max File No	64*
			128
			196
	Counter Reset	Fuser	
		Pickup Roller	Tray 1
			Tray 2
			Tray 3
	MP Tray		
	Adjust Margin	Top Margin	[-10~10]:
		Left Margin	[-10~10]:
	B2B Mode	[0-99] 0*	
	Toner Low Level	[1~30]: 10 %*	
	Paper Substitution	Off *	
On			
Report	Menu Map	Printing...	
	Supplies info	Printing...	
	Event Log	Printing...	
	ACR Reprint	Printing...	
	Job Duty Report	Printing...	
	ID Control History	Printing...	
EDC Mode	NVM Read/Write		
	NVM Initialization	Initialize Now?	
	Test Routine		
	Manual settings	X Offset Left Y	[-5~5] 0*
		X Offset Left M	[-5~5] 0*
		X Offset Left C	[-5~5] 0*
		X Offset Center Y	[-5~5] 0*
		X Offset Center M	[-5~5] 0*
		X Offset Center C	[-5~5] 0*
		X Offset Right Y	[-5~5] 0*
		X Offset Right M	[-5~5] 0*
X Offset Right C	[-5~5] 0*		
Regi Pattern	Printing...		

### 4.1.8.3. Tech Mode Menu description

---

#### 1) Data Setup

- **HDD Setup**

This menu can format the hard disk or set up the maximum number of files that you can store. You can see this menu when the HDD is installed in the machine.

- **Counter Reset**

This menu can reset the counts for the Fuser or Pick up roller or Transfer roller.  
When replacing these parts, you must do this menu.

- **Adjust Margin**

This menu can adjust the paper margin.

- **B2B Mode**

This menu can set B2B mode.

- **Toner Low Level**

When the toner remains less than setting up level, the machine notify user of toner low.

- **Paper Substitution**

Between A4 and Letter size paper, print job can be executed without paper mismatch message, when the setting value is "On".

#### 2) Report

- **Supplies Info**

It shows consumable unit life status and toner using status.

- **Event Log**

It shows various kinds of errors which can be occurred in machine. It also store history error count how many errors are issued.

- **ACR Report**

It shows ACR(Auto Color Registration) performance history.

- **Job Duty Report**

It shows printing usage by print job duty.

- **ID Control History**

It shows image density control history.

#### 3) EDC Mode

- **NVRAM Read/Write**

This menu can change a configuration value for engine firmware.

Depth 1	Depth 2	Min/Max, Default	Meaning
105-Duty	0030-MHV DC K	[-15~15] 0*	Set up the Charger(MHV)'s DC control duty
106-Deve	0000-Deve DC Y	[-25~25] 0*	Set up the Yellow Dev DC control duty
	0010-Deve DC M	[-25~25] 0*	Set up the Magenta Dev DC control duty
	0020-Deve DC C	[-25~25] 0*	Set up the Cyan Dev DC control duty
	0030-Deve DC K	[-25~25] 0*	Set up the Black Dev DC control duty
	0040-Deve VPP Y	[-25~25] 0*	Set up the Yellow Dev PP control duty
	0050-Deve VPP M	[-25~25] 0*	Set up the Magenta Dev PP control duty
	0060-Deve VPP C	[-25~25] 0*	Set up the Cyan Dev PP control duty
	0070-Deve VPP K	[-25~25] 0*	Set up the Black Dev PP control duty
	0080-Dev AC Y	[-25~25] 0*	Set up the Yellow Dev AC control duty
	0090-Dev AC M	[-25~25] 0*	Set up the Magenta Dev AC control duty
	0100-Dev AC C	[-25~25] 0*	Set up the Cyan Dev AC control duty
	0110-Dev AC K	[-25~25] 0*	Set up the Black Dev AC control duty
	0120-Deve AC Freq	[-500~500] 0*	Set up the Dev AC frequency
107-Transfer	0000-THV Y	[-25~25] 0*	Set up the yellow transfer DC normal voltage control duty
	0010-THV M	[-25~25] 0*	Set up the magenta transfer DC normal voltage control duty
	0020-THV C	[-25~25] 0*	Set up the cyan transfer DC normal voltage control duty
	0030-THV K	[-25~25] 0*	Set up the black transfer DC normal voltage control duty
	0040-THV Low Y	[-10~10] 0*	Set up the yellow transfer DC low voltage control duty
	0050-THV Low M	[-10~10] 0*	Set up the magenta transfer DC low voltage control duty
	0060-THV Low C	[-10~10] 0*	Set up the cyan transfer DC low voltage control duty
	0070-THV Low K	[-10~10] 0*	Set up the black transfer DC low voltage control duty
0130-ATTR+ Bias	[-10~10] 0*	Set up the ATTR plus bias voltage on at normal drive level	
109-Temp Offset	0000-Ready Temp	[-10~10] 0*	Target Temperature value setting during standby state.
	0010-Print Temp	[-10~10] 0*	Target Temperature value setting during print state.
	0020-Low Power Temp	[-10~10] 0*	Target Temperature value setting during power save state.
	0070-Bond Temp	[-10~10] 0*	Bond type paper fixing temperature offset
	0080-Trans Temp	[-10~10] 0*	Transparency(OHP) type paper temperature offset
	0100-Envelopes Temp	[-10~10] 0*	Envelopes type paper temperature offset
	0110-Labels Temp	[-10~10] 0*	Labels type paper temperature offset
	0120-Fuser Bias Duty	[-10~10] 0*	Set up the fuser roll voltage control duty
	0130-Thick Temp	[-10~10] 0*	Thick type paper temperature offset
110-LD Power	0040-LD Power Y	[-10~10] 0*	Yellow LD Power at Normal Speed
	0050-LD Power M	[-10~10] 0*	Magenta LD Power at Normal Speed
	0060-LD Power C	[-10~10] 0*	Cyan LD Power at Normal Speed
	0070-LD Power K	[-10~10] 0*	Black LD Power at Normal Speed
111-Toner			Not Available

Depth 1	Depth 2	Min/Max, Default	Meaning
112-ACR Offset	0000-ACR Condition	[0~1] 1*	All Condition of ACR On/Off (On 1, Off 0)
	0010-ACR Inner Temp	[0~1] 1*	The Condition for Inner Temperature of ACR On/Off (On 1, Off 0)
	0020-ACR LSU Temp	[0~1] 1*	The Condition for LSU Temperature of ACR On/Off (On 1, Off 0)
	0030-ACR New CRU	[0~1] 1*	The Condition for New Crum of ACR On/Off (On 1, Off 0)
	0040-ACR Page Cnt	[0~1] 1*	The Condition for Page Count of ACR On/Off (On 1, Off 0)
	0050-Fuser Motor Speed	[-10~10] 0*	The Fuser Motor Speed Offset for Regi.

• **Test Routines**

This menu can perform the operation test for the main components.

Depth1	Depth2	Meaning
100-Motor	0040-Color OPC	Color OPC BLDC Motor is On/Off
	0050-Color OPC Rdy	Detect if Color DEV BLDC Motor runs at normal speed
	0060-Color Dev	Color DEV BLDC Motor is On/Off
	0070-Color Dev Rdy	Detect if Color DEV BLDC Motor runs at normal speed
	0191-System Fan Run	Start/Stop System Fan run
	0192-System Fan Rdy	Detects if System Fan runs at normal speed.
	0193-HVPS Fan	Start/Stop HVPS Fan run
	0194-HVPS Fan Rdy	Detects if HVPS Fan runs at normal speed.
101-Clutch	0000-MP Feed Clutch	Engages drive to pick up a paper from bypass Tray(MP Tray).
	0010-Tray1 Pickup	Engages drive to pick up a paper from tray1.
	0020-Tray2 Pickup	Engages drive to pick up a paper from tray2. (Optional)
	0030-Tray3 Pickup	Engages drive to pick up a paper from tray3. (Optional)
	0050-Registration	Engages drive to registartion rolls.
	0120-Tray1 Feed Mot	T1 Feed Motor On/Off
	0130-Tray2 Feed Mot	T2 Feed Motor On/Off
	0140-Tray3 Feed Mot	T3 Feed Motor On/Off
	0190-OutBin Full	Detect a paper full in Outbin
102-Sensor	0000-Tray1 Home Pos	Detect when tray1 is closed.
	0010-Tray1 Empty	Detect when paper is in Tray1.
	0020-Tray1 Size1	Detects whether auto size1 sensor of tray1 is high or low.
	0030-Tray1 Size2	Detects whether auto size2 sensor of tray1 is high or low.
	0040-Tray1 Size3	Detects whether auto size3 sensor of tray1 is high or low.
	0070-Tray2 Home Pos	Detect when tray2 is closed.
	0080-Tray2 Empty	Detect when paper is in tray2.
	0090-Tray2 Size1	Detects whether auto size1 sensor of tray2 is high or low.
	0100-Tray2 Size2	Detects whether auto size2 sensor of tray2 is high or low.
	0110-Tray2 Size3	Detects whether auto size3 sensor of tray2 is high or low.
	0140-Tray3 Home Pos	Detect when tray3 is closed.



Depth1	Depth2	Meaning
	0150-Tray3 Empty	Detect when paper is in tray3.
	0160-Tray3 Size1	Detects whether auto size1 sensor of tray3 is high or low.
	0170-Tray3 Size2	Detects whether auto size2 sensor of tray3 is high or low.
	0180-Tray3 Size3	Detects whether auto size3 sensor of tray3 is high or low.
	0280-MP Empty	Detects when paper is in Bypass Tray(MP Tray).
	0290-Feed Sensor	Detect when a paper is at Feed sensor.
	0360-Regi Sens	Detect when a paper is at Regi. sensor.
	0370-Exit Sens	Detect when a paper is at Exit. sensor.
105-MHV Bias	0000-Y MHV Bias	Yellow MHV bias voltage on at normal drive level
	0010-M MHV Bias	Magenta, Cyan MHV bias voltage on at normal drive level
	0030-K MHV Bias	Black MHV bias voltage on at normal drive level
	0100-M MHV AC	Magenta, Cyan MHV AC bias voltage on at normal drive level
	0120-K MHV AC	Black MHV AC bias voltage on at normal drive level
106-Dev Bias	0000-Y Dev Bias	Yellow Dev bias voltage on at normal drive level
	0010-M Dev Bias	Magenta Dev bias voltage on at normal drive level
	0020-C Dev Bias	Cyan Dev bias voltage on at normal drive level
	0030-K Dev Bias	Black Dev bias voltage on at normal drive level
	0031-K Dev AC	Black Dev bias AC voltage on at normal drive level
	0032-C Dev AC	Cyan Dev bias AC voltage on at normal drive level
	0033-M Dev AC	Magenta Dev bias AC voltage on at normal drive level
	0034-Y Dev AC	Yellow Dev bias AC voltage on at normal drive level
107-Transfer Bias	0000-Y THV Bias	Yellow THV bias voltage on at normal drive level
	0010-M THV Bias	Magenta THV bias voltage on at normal drive level
	0020-C THV Bias	Cyan THV bias voltage on at normal drive level
	0030-K THV Bias	Black THV bias voltage on at normal drive level
	0040-Y THV Bias R	Detect what the THV value is on the THV Roller
	0120-ATTR+ Bias	ATTR plus bias voltage on at normal drive level
	0140-ATTR- Bias	ATTR Minus bias voltage on at normal drive level
	0160-Erase Lamp	Make a OPC surface voltage equal
109-Fuser Heater	0000-Temp A	Detects what the temperature center is on fuser.
	0010-Temp B	Detects what the temperature side is on fuser.
	0030-Fuser Mot Fwd	Fuser Motor Forward On/Off
	0031-Fuser Mot Bwd	Fuser Motor Backward On/Off
	0040-Fuser Fan Run	Fuser Fan Motor On/Off
	0050-Fuser Bias	Fuser bias voltage on at normal drive level
	0090-Fuser Power On	It controls temperature of fuser as 180 degrees.
	0110-Fuser Fuse 1 R	Detect if the life of fuser1 is exhausted.

Depth1	Depth2	Meaning
110-LSU	0000-LSU Motor 1 Rdy	Detects if LSU motor1 runs at normal speed.
	0010-LSU Motor 2 Rdy	Detects if LSU motor2 runs at normal speed.
	0060-LSU Motor 1 Run	LSU Motor1 On/Off
	0070-LSU Motor 2 Run	LSU Motor2 On/Off
	0080-LD Power 1	LSU LD1 enable On/Off (yellow)
	0090-LD Power 2	LSU LD2 enable On/Off (magenta)
	0100-LD Power 3	LSU LD3 enable On/Off (cyan)
	0110-LD Power 4	LSU LD4 enable On/Off (black)
112-ACR	0010-Manu Regi Clear	Clear Manual Offset Value of Color Regi.

- **Manual Settings**

This menu can set up the offset manually.

- **Regi Pattern**

This menu can print the regi pattern.

## 4.2. Troubleshooting

### 4.2.1. Procedure of Checking the Symptoms

Before attempting to repair the printer first obtain a detailed description of the problem from the customer.

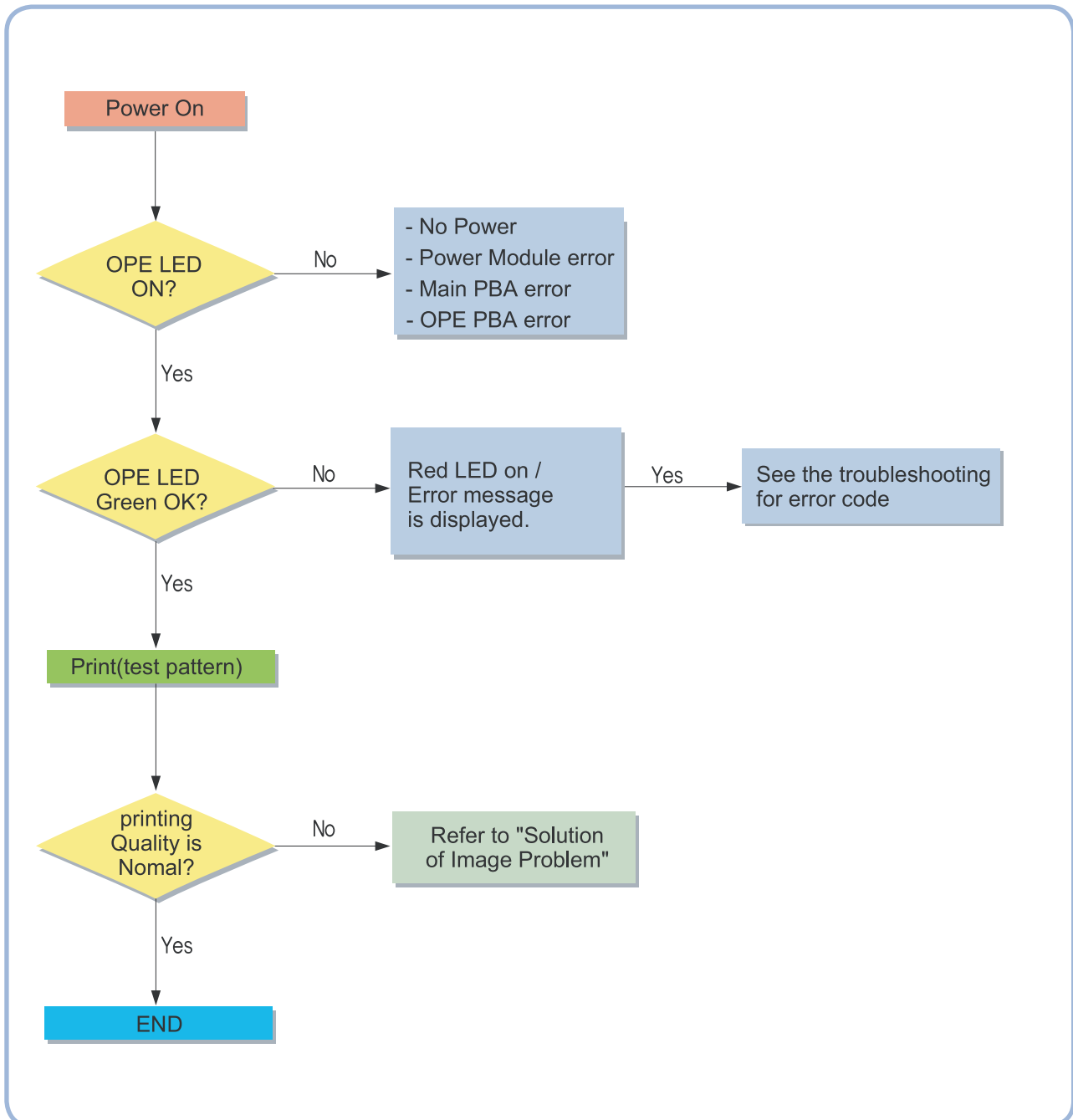

#### 4.2.1.1. Basic Check List

---

1) **Check the Power.**

- Check that the power switch is turned on.
- Check that the power cable is plugged into the outlet and the printer.
- Check the voltage of the power outlet.

2) **Check the LED of Panel.**

- Is there OPE LED ON?
  - › If not check power cable, switch SMPS or Main board.
- Is the abnormal Lamp?
  - › Check the Main board and cable harness.

3) **Check the Paper Path**

- Is there a Paper Jam?
  - › Remove any paper fragments caught in the paper path.
- Paper Jam occurs repeatedly at a specific point in the Paper Path
  - › Open the fuser cover, Jam clear.
  - › Dismantle the machine and carefully inspect the region where the jam occurs.  
(Especially, check if paper fragments are caught in the Fuser)

4) **Print the Information Page (Configuration).**

- Try printing a test page from a computer.
  - › If there is an error check cables and driver installation.

5) **Check the Print Quality.**

- Is there are a Print Quality Problem?
  - › Refer to image quality problem section.

6) **Check consumables (toner etc.).**

- Using the keys print the Test Pattern.
  - › Expected life of various consumable parts, compare this with the figures printed and replace as required

## 4.2.2. Error code and troubleshooting

Error code and messages appear on LCD Panel display to indicate the machine's status or errors. Also, error in machine can be checked through "Event Log Information" report.

Error Code	Error Message	Troubleshooting Page
A1-1110	Error: #A1-1110 / Actuator Motor Failure: #A1-1110.Turn off then on.	P.4-28
A1-1210	Error: #A1-1210 / Actuator Motor Failure: #A1-1210.Call for service.	P.4-29
A1-3622	Error: #A1-3622 / Actuator Motor Failure: #A1-3622. Call for service.	P.4-30
A2-1110	Error: #A2-1110 / Actuator Fan Failure: #A2-1110. Call for service.	P.4-31
A3-3111	Error: #A3-3111 / Actuator Sensor Failure: #A3-3111. Call for service.	P.4-32
A3-3112	Error: #A3-3112 / Actuator Sensor Failure: #A3-3112. Call for service.	P.4-32
A3-3320	Not Proper room temp / Not proper room temperature. Change room temperature.	P.4-35
C2-2110	Prepare new Y toner / Prepare new yellow toner cartridge.	P.4-35
C2-2120	Replace new Y toner / Replace with new yellow toner cartridge.	P.4-36
C2-2140	Replace new Y toner / End of life, Replace with new yellow toner cartridge.	P.4-36
C2-2150	Replace new Y toner / Replace with new yellow toner cartridge.	P.4-36
C2-2410	Y toner not installed / Yellow toner cartridge is not installed. Install toner.	P.4-37
C2-2512	Y toner not compatible / Yellow toner cartridge is not compatible. Check guide.	P.4-38
C2-3110	Prepare new M toner / Prepare new magenta toner cartridge.	P.4-35
C2-3120	Replace new M toner / Replace with new magenta toner cartridge.	P.4-36
C2-3140	Replace new M toner / End of life, Replace with new magenta toner cartridge.	P.4-36
C2-3150	Replace new M toner / Replace with new magenta toner cartridge.	P.4-36
C2-3410	M toner Not Installed / Magenta Toner cartridge is not installed. Install Toner.	P.4-37
C2-3512	M toner Not Compatible / Magenta toner cartridge is not compatible. Check guide.	P.4-38
C2-4110	Prepare new C toner / Prepare new cyan toner cartridge.	P.4-35
C2-4120	Replace new C toner / Replace with new cyan toner cartridge.	P.4-36
C2-4140	Replace new C toner / End of life, Replace with new cyan toner cartridge.	P.4-36
C2-4150	Replace new C toner / Replace with new cyan toner cartridge.	P.4-36
C2-4410	C toner not installed / Cyan toner cartridge is not installed. Install toner.	P.4-37
C2-4512	C toner Not Compatible / Cyan toner cartridge is not compatible. Check guide.	P.4-38
C2-5110	Prepare new K toner / Prepare new black toner cartridge.	P.4-35
C2-5120	Replace new K toner / Replace with new black toner cartridge.	P.4-36
C2-5140	Replace new K toner / End of life, Replace with new black toner cartridge.	P.4-36
C2-5150	Replace new K toner / Replace with new black toner cartridge.	P.4-36
C2-5410	K toner not installed / Black toner cartridge is not installed. Install it.	P.4-37
C2-5512	K toner not compatible / Black toner cartridge is not compatible. Check guide.	P.4-38
C4-1110	Prepare Transfer belt / Prepare new Transfer belt unit	P.4-39
C4-1120	Replace TR. belt / Replace with new Transfer belt unit	P.4-39

#### 4. Alignment and Troubleshooting

Error Code	Error Message	Troubleshooting Page
C4-1130	Replace TR. belt / End of life. Replace with new Transfer belt unit	P.4-39
C4-1210	Error:#C4-1210 / PTB Unit Failure #C4-1210: Install paper transfer belt unit.	P.4-39
C4-1412	TR belt not compatible / Paper transfer belt unit is not compatible. Check guide	P.4-39
C6-1110	Prepare Fuser unit / Prepare new fuser unit.	P.4-40
C6-1120	Replace Fuser unit / Replace with new fuser unit.	P.4-40
C9-1115	Replace retard roller / Replace with new Tray1 retard roller	P.4-41
C9-1125	Replace retard roller / Replace with new Tray2 retard roller	P.4-41
C9-1135	Replace retard roller / Replace with new Tray3 retard roller	P.4-41
C9-3112	Replace dust cleaning / Replace with new dust cleaning kit	P.4-42
H1-1210	Paper Jam in Tray 2.	P.4-43
H1-1222	Tray 2 cassette Out / Tray 2 cassette is pulled out. Insert it properly.	P.4-45
H1-1252	Paper Empty in Tray 2 / Paper is empty in Tray 2. Load paper.	P.4-46
H1-1310	Paper Jam in Tray 3.	P.4-43
H1-1322	Tray 3 cassette Out / Tray 3 cassette is pulled out. Insert it properly.	P.4-45
H1-1352	Paper Empty in Tray 3 / Paper is empty in Tray 3. Load paper.	P.4-46
M1-1110	Paper Jam in Tray 1.	P.4-47
M1-1610	Paper Jam in MP tray.	P.4-49
M1-3122	Tray1 cassette Out / Tray1 cassette is pulled out. Insert it properly.	P.4-50
M1-5112	Paper Empty in tray1 / Paper is emptyin tray1. Load paper.	P.4-51
M1-5612	Paper Empty in MP / Paper is emptyin MP tray. Load paper.	P.4-52
M2-1110	Jam inside machine.	P.4-53
M2-2310	Jam bottom of duplex.	P.4-54
M3-1110	Jam in exit area.	P.4-55
M3-2130	Output bin full / Output bin full. Remove printed paper.	P.4-56
S2-1523	Error: #S2-1523 / Engine System Failure: #S2-1523. Turn off then on.	P.4-57
S2-4121	Door is open or Check Transfer belt.	P.4-57
S6-3123	IP Conflict / This IP address conflicts with that of other system.	P.4-58
S6-3128	802.1x Network Error / 802.1x Network Error Contact the Admin.	P.4-58
U1-2320	Error: #U1-2320/ Fuser Unit Failure: #U1-2320.Turn off then on.	P.4-32
U1-2330	Error: #U1-2330 / Fuser Unit Failure: #U1-2330.Turn off then on.	P.4-32
U1-2340	Error: #U1-2340 / Fuser Unit Failure: #U1-2340.Turn off then on.	P.4-32
U2-6133	Error: #U2-6133 / LSU Unit Failure: #U2-6133. Turn off then on.	P.4-58
U2-6134	Error: #U2-6134 / LSU Unit Failure: #U2-6134. Turn off then on.	P.4-58
U2-6142	Error: #U2-6142 / LSU Unit Failure: #U2-6142. Turn off then on.	P.4-59
U2-6143	Error: #U2-6143 / LSU Unit Failure: #U2-6143. Turn off then on	P.4-59

**▶ Error Code**

A1-1110

**▶ Error message**

Error: #A1-1110 / Actuator Motor Failure: #A1-1110

**▶ Symptom**

Main BLDC motor doesn't work normally.

**▶ Troubleshooting method**

※ First, turn the machine off then on. If the error persists, refer to the following.

- 1) Turn the machine off. Check if there are any papers or foreign matter inside the machine.
- 2) Check if the Main BLDC motor connector is connected properly. Reconnect it.



- 3) If the toner cartridge is overloaded, replace it.
- 4) If the Main BLDC motor is defective, replace it.
- 5) If the problem persists after replacing the Main BLDC motor, replace the main board.

▶ **Error Code**

A1-1210

▶ **Error message**

Error: #A1-1210 / Actuator Motor Failure: #A1-1210.

▶ **Symptom**

Fuser BLDC motor doesn't work normally.

▶ **Troubleshooting method**

※ First, turn the machine off then on. If the error persists, refer to the following.

- 1) Turn the machine off. Check if there are any papers or foreign matter inside the machine.
- 2) Check if the Fuser BLDC motor connector is connected properly. Reconnect it.

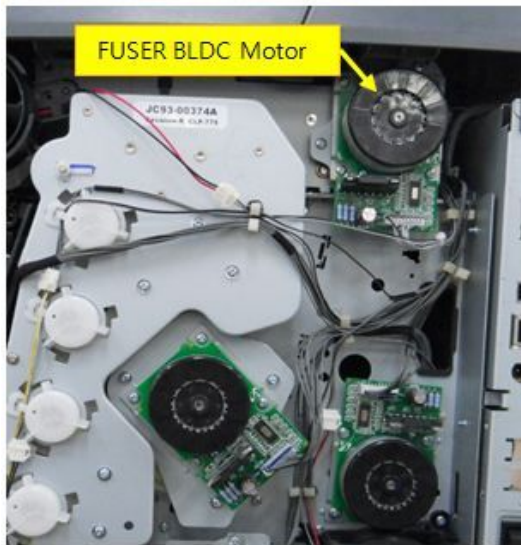

- 3) If the toner cartridge is overloaded, replace it.
- 4) If the Fuser BLDC motor is defective, replace it.
- 5) If the problem persists after replacing the Fuser BLDC motor, replace the main board.



**▶ Error Code**

A1-3622

**▶ Error message**

Error: #A1-3622 / Actuator Motor Failure: #A1-3622.

**▶ Symptom**

DEVE BLDC motor doesn't work normally.

**▶ Troubleshooting method**

※ First, turn the machine off then on. If the error persists, refer to the following.

- 1) Turn the machine off. Check if there are any papers or foreign matter inside the machine.
- 2) Check if the DEVE BLDC motor connector is connected properly. Reconnect it.

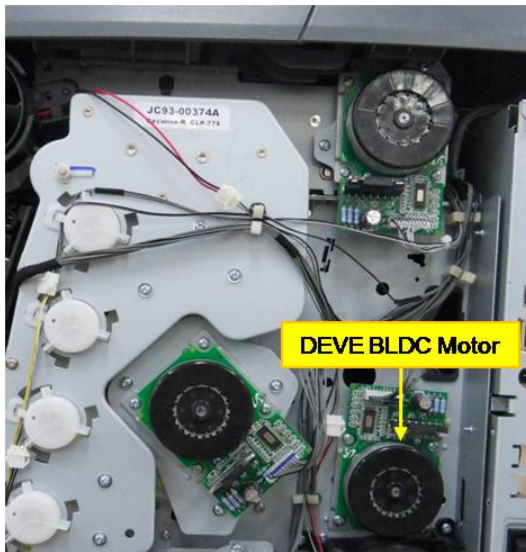

- 3) If the toner cartridge is overloaded, replace it.
- 4) If the DEVE BLDC motor is defective, replace it.
- 5) If the problem persists after replacing the DEVE BLDC motor, replace the main board.

▶ **Error Code**

A2-1110

▶ **Error message**

Error: #A2-1110 / Actuator Motor Failure: #A2-1110.

▶ **Symptom**

System Fan doesn't work.

▶ **Troubleshooting method**

※ First, turn the machine off then on. If the error persists, refer to the following.

- 1) Check if the fan connector on Main board is connected properly.

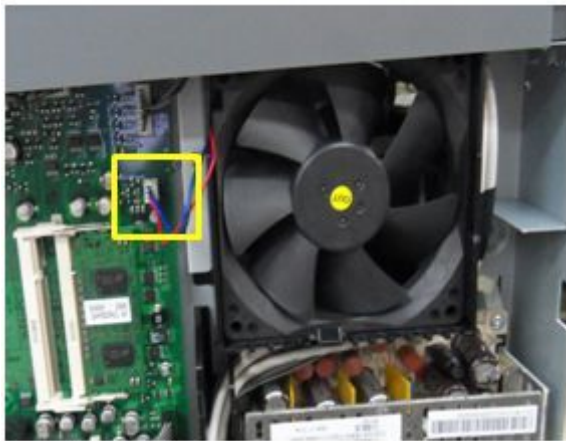

- 2) If the fan is defective, replace it.
- 3) If the problem persists after replacing the fan, replace the main board.

► **Error Code**

A3-3111

A3-3112

U1-2320

U1-2330

U1-2340

► **Error message**

Error: #A3-3111 / Actuator Sensor Failure: #A3-3111.

Error: #A3-3112 / Actuator Sensor Failure: #A3-3112.

Error: #U1-2320/ Fuser Unit Failure: #U1-2320. Turn off then on.

Error: #U1-2330/ Fuser Unit Failure: #U1-2330. Turn off then on.

Error: #U1-2340/ Fuser Unit Failure: #U1-2340. Turn off then on.

► **Symptom**

Thermistor error (A3-3111/3112) or Fuser error (U1-2320/2330/2340) has occurred.

► **Troubleshooting method**



**NOTE**

For repairing the fuser unit, refer to the newest service bulletin.

Symptom	Check point	Result	Action
The fuser unit is melted.	SMPS Triac	Normal (Open)	Case1) Replace the fuser unit and main board.
		Abnormal (Short)	Case2) Replace the fuser unit and SMPS.
	Thermistor	Normal (Contact)	Case3) Replace the fuser unit and main board. Check the SMPS Triac.
		Abnormal (Non-Contact)	Case4) Replace the fuser unit. Check the SMPS Triac.
	Thermostat	Normal (Short)	Case5) SET Swap.
		Abnormal (Open)	Case6) Replace the fuser unit. Check the SMPS Triac.
The fuser unit is not melted but the thermostat is open.	SMPS Triac	Normal (Open)	Case7) Replace the fuser unit and main board.
		Abnormal (Short)	Case8) Replace the fuser unit and SMPS.
	Thermistor	Normal (Contact)	Case9) Replace the fuser unit and main board. Check the SMPS Triac.
		Abnormal (Non-Contact)	Case10) Replace the fuser unit. Check the SMPS Triac.

1) Replace the fuser unit.

- a) Open the top cover. Remove 4 screws.



- b) Lift the fuser unit up while pushing the lever.

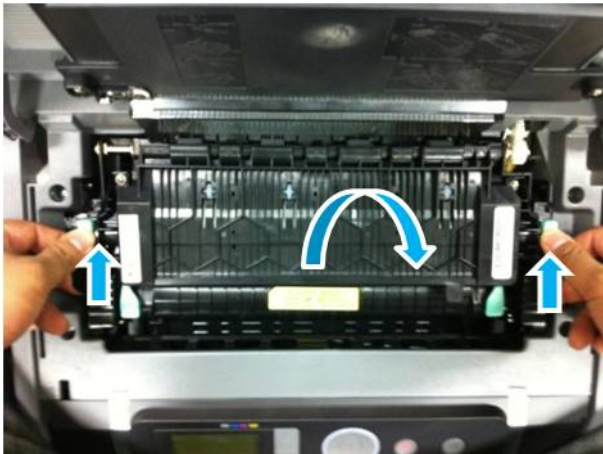

- c) Check if the thermistor contacts the heat roller surface.

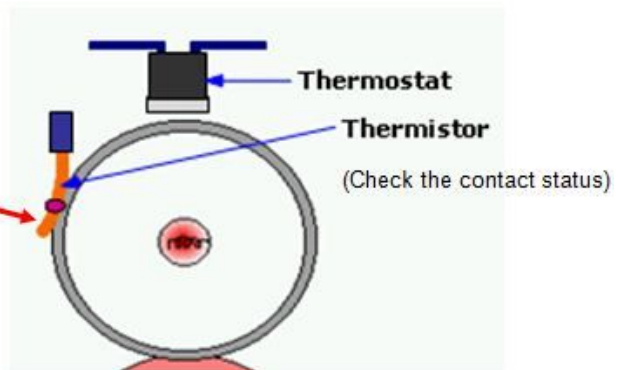

- 2) Check the SMPS Triac.

Measure the resistance value on each checking points with DVM.



[ SMPS Triac ]

Checking points	Normal value
A ↔ B	Open
A ↔ C	More than 10Ω
B ↔ C	Open

▶ **Error Code**

A3-3320

▶ **Error message**

Not Proper room temp / Not proper room temperature. Change room temperature.

▶ **Symptom**

The external temperature sensor has detected the abnormal value.

▶ **Troubleshooting method**

- 1) Check if the machine is installed in proper area. (Temperature : 15 °C ~ 32.5 °C). If not, move the machine.

▶ **Error Code**

C2-2110

C2-3110

C2-4110

C2-5110

▶ **Error message**

Prepare new Y toner / Prepare new yellow toner cartridge.

Prepare new M toner / Prepare new magenta toner cartridge.

Prepare new C toner / Prepare new cyan toner cartridge.

Prepare new K toner / Prepare new black toner cartridge.

▶ **Symptom**

The remaining toner in cartridge is low.

▶ **Troubleshooting method**

- 1) Print the Supply Information report. Check the toner cartridge life.
- 2) If its life is at the end, turn the machine off and replace the corresponding toner cartridge with new one.

**► Error Code**

C2-2120

C2-2140

C2-2150

C2-3120

C2-3140

C2-3150

C2-4120

C2-4140

C2-4150

C2-5120

C2-5140

C2-5150

**► Error message**

Replace new Y toner / Replace with new yellow toner cartridge.

Replace new Y toner / End of life, Replace with new yellow toner cartridge.

Replace new Y toner / Replace with new yellow toner cartridge.

Replace new M toner / Replace with new magenta toner cartridge.

Replace new M toner / End of life, Replace with new magenta toner cartridge.

Replace new M toner / Replace with new magenta toner cartridge.

Replace new C toner / Replace with new cyan toner cartridge.

Replace new C toner / End of life, Replace with new cyan toner cartridge.

Replace new C toner / Replace with new cyan toner cartridge.

Replace new K toner / Replace with new black toner cartridge.

Replace new K toner / End of life, Replace with new black toner cartridge.

Replace new K toner / Replace with new black toner cartridge.

**► Symptom**

The remaining toner in cartridge is empty.

**► Troubleshooting method**

- 1) Print the Supply Information report. Check the toner cartridge life.
- 2) If its life is at the end, turn the machine off and replace the corresponding toner cartridge with new one.

▶ **Error Code**

C2-2410

C2-3410

C2-4410

C2-5410

▶ **Error message**

Y toner not installed / Yellow toner cartridge is not installed. Install toner.

M toner Not Installed / Magenta Toner cartridge is not installed. Install Toner.

C toner not installed / Cyan toner cartridge is not installed. Install toner.

K toner not installed / Black toner cartridge is not installed. Install it.

▶ **Symptom**

The toner cartridge is not installed properly.

▶ **Troubleshooting method**

- 1) Open the front cover. Remove the corresponding toner cartridge. And reinstall it.
- 2) If the problem persists, check the Deve CRUM CN5 connector on main board.

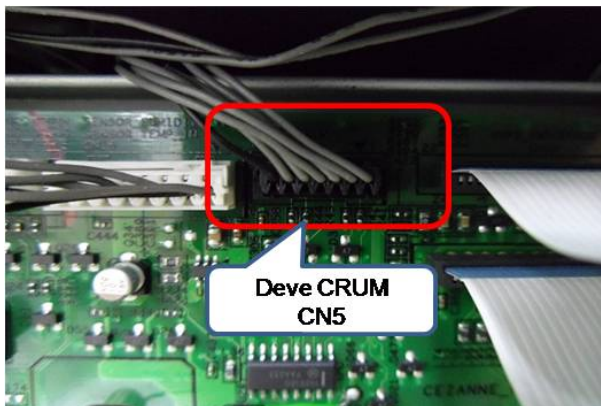

- 3) Check if the DEVE CRUM I/F Pin and Deve CRUM terminal are contaminated.

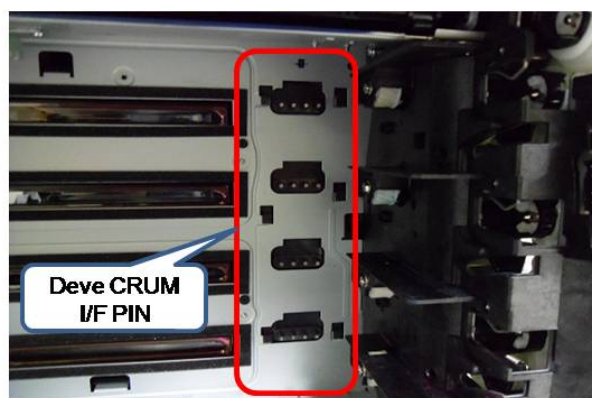
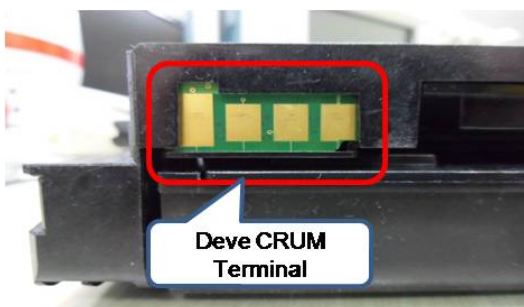



**► Error Code**

C2-2512

C2-3512

C2-4512

C2-5512

**► Error message**

Y toner not compatible / Yellow toner cartridge is not compatible. Check guide.

M toner Not compatible / Magenta toner cartridge is not compatible. Check guide.

C toner Not compatible / Cyan toner cartridge is not compatible. Check guide.

K toner not compatible / Black toner cartridge is not compatible. Check guide.

**► Symptom**

The toner cartridge is not installed properly.

**► Troubleshooting method**

- 1) Open the front cover. Check if each color cartridge is inserted in proper position.



- 2) Replace the samsung genuine toner cartridge.

▶ **Error Code**

C4-1110

C4-1120

C4-1130

▶ **Error message**

Prepare Transfer belt / Prepare new Transfer belt unit

Replace TR. belt / Replace with new Transfer belt unit

Replace TR. belt / End of life. Replace with new Transfer belt unit

▶ **Symptom**

The PTB unit is at the end of its life.

▶ **Troubleshooting method**

- 1) Print the Supply Information report. Check the PTB (Paper Transfer Belt) unit life.
- 2) If its life is at the end, replace the PTB unit with new one.



▶ **Error Code**

C4-1210

C4-1412

▶ **Error message**

Error:#C4-1210 / PTB Unit Failure #C4-1210: Install paper transfer belt unit.

TR belt not compatible / Paper transfer belt unit is not compatible. Check guide.

▶ **Symptom**

The PTB unit is not installed properly. / The PTB unit is not compatible.

▶ **Troubleshooting method**

- 1) Open the front cover. Remove the PTB unit.
- 2) Check the model name. If it is not samsung genuine PTB unit, replace it.

▶ **Error Code**

C6-1110

C6-1120

▶ **Error message**

Prepare Fuser unit / Prepare new fuser unit.

Replace Fuser unit / Replace with new fuser unit.

▶ **Symptom**

The fuser unit is at the end of its life.

▶ **Troubleshooting method**

- 1) Open the top cover. Remove 4 screws.



- 2) Lift the fuser unit up while pushing the lever.

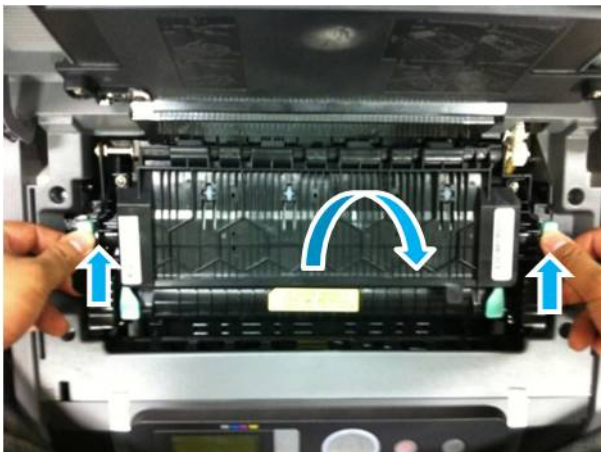

▶ **Error Code**

C9-1115

▶ **Error message**

Replace retard roller / Replace with new Tray1 retard roller.

▶ **Symptom**

Tray1 retard roller is at the end of its life.

▶ **Troubleshooting method**

- 1) Print the Supply Information report. Check the retard roller life.
- 2) Remove the tray1.
- 3) Replace the retard roller with new one. (Refer to 3.3.3 Retard roller)



▶ **Error Code**

C9-1125

C9-1135

▶ **Error message**

Replace retard roller / Replace with new Tray2 retard roller.

Replace retard roller / Replace with new Tray3 retard roller.

▶ **Symptom**

Tray2,3 retard roller is at the end of its life.

▶ **Troubleshooting method**

- 1) Print the Supply Information report. Check the retard roller life.
- 2) Remove the corresponding tray.
- 3) Replace the retard roller with new one.

▶ **Error Code**

C9-3112

▶ **Error message**

Replace dust cleaning / Replace with new dust cleaning kit.

▶ **Symptom**

Dust cleaning kit is at the end of its life.

▶ **Troubleshooting method**

- 1) Open the front cover.
- 2) Remove the PTB unit.
- 3) Replace the dust cleaning kit with new one.(Refer to 3.3.4. Dust Cleaning Kit)



► **Error Code**

H1-1210

H1-1310

► **Error message**

Paper Jam in Tray 2.

Paper Jam in Tray 3.

► **Symptom**

A jammed paper has occurred in the optional tray. (SCF unit)

► **Troubleshooting method**

- 1) Remove the jammed paper from the corresponding tray. If the problem persists, check the followings.
- 2) Check if the paper is loaded in the optional tray properly.



- 3) Check if the forward and pickup rollers are defective or worn out.

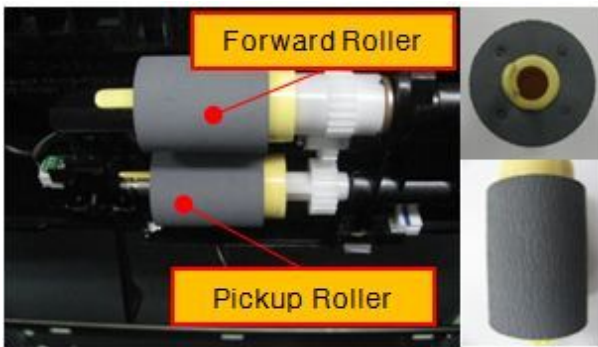

- 4) Check if the Empty/Pickup/Regi-Act sensors are working properly.

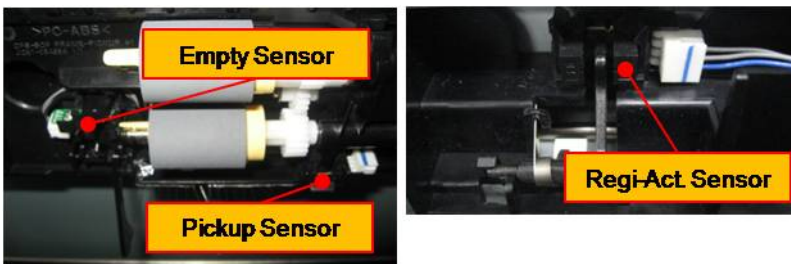

- 5) Check if the SCF main board, motor, clutches connectors are connected properly.

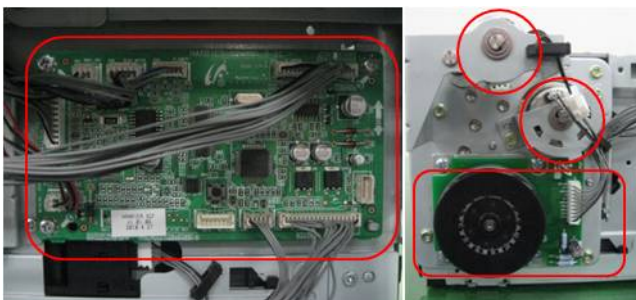

- 6) Check if the AS-SPRING\_ES is deformed or assembled properly.

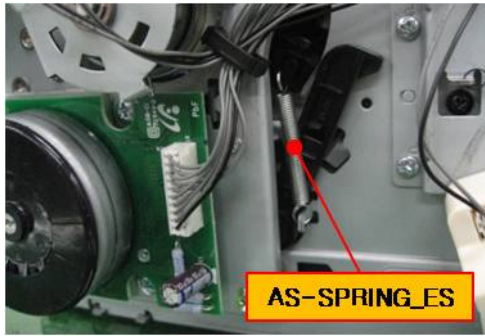

- 7) Check if the Press D-cut of the Gear-Lifting is broken.

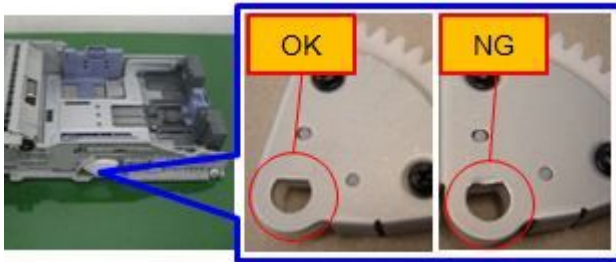

- 8) If the problem persists after checking No. 1~7, replace the SCF main board.
- 9) If the problem persists after replace the SCF main board, replace the Draw connector.

▶ **Error Code**

H1-1222

H1-1322

▶ **Error message**

Tray 2 cassette Out

Tray 3 cassette Out

▶ **Symptom**

A optional tray cassette is pulled out.

▶ **Troubleshooting method**

- 1) Check if the optional cassette is inserted properly. Remove the cassette then re-install it.
- 2) Check if the Signal-Switch is deformed or broken. If it is defective, replace it.

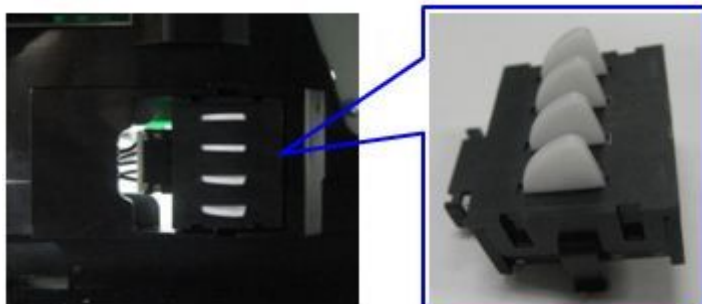



**▶ Error Code**

H1-1252

H1-1352

**▶ Error message**

Paper Empty in Tray 2

Paper Empty in Tray 3

**▶ Symptom**

Paper in the optional cassette is empty.

**▶ Troubleshooting method**

- 1) Check if the paper in optional cassette is loaded. Load the paper.
- 2) Check if the Empty actuator and Empty sensor work properly.

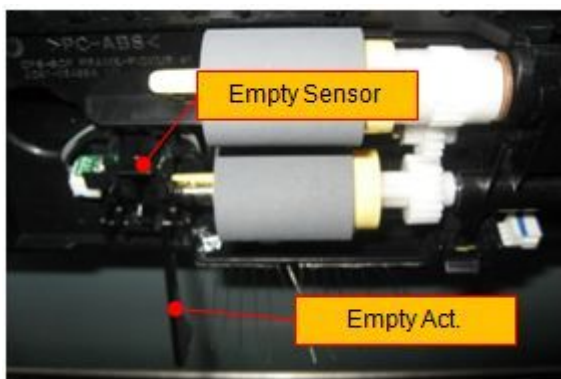

- 3) If the Empty actuator is defective, replace it.
- 4) If the Empty sensor is defective, replace it.

▶ **Error Code**

M1-1110

▶ **Error message**

Paper Jam in Tray 1.

▶ **Symptom**

A jammed paper has occurred in the Tray 1.

▶ **Troubleshooting method**

- 1) Remove the tray 1. If there is the jammed paper inside the machine, remove it.  
If the problem persists, check the following.
- 2) Check if the paper guide is adjusted properly.
- 3) Check if the Pickup, Feed, Retard rollers are contaminated or worn out. Clean or replace it if necessary.

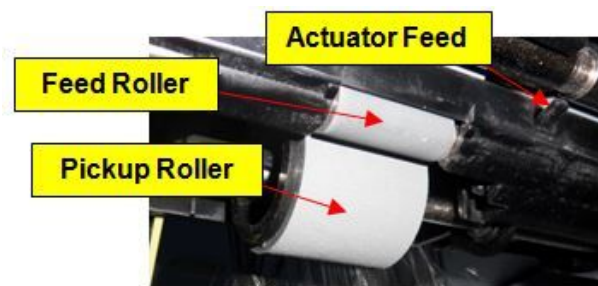

- 4) Check if there are any obstacles or contamination on the paper path.
- 5) If the Pick up roller doesn't operate, check the gear and clutch from the end of shaft.

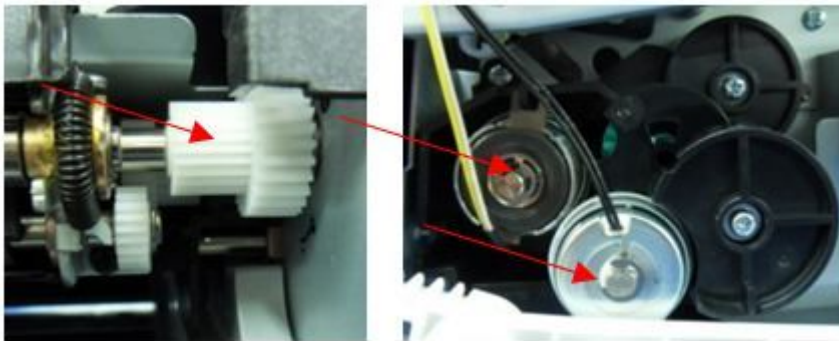

- 6) If the Pick up roller rotates but paper is not fed, check for dirty or worn out roller.

- 7) Check if the CN 1,2,4,5,9 and flat cable on HVPS board is connected properly.

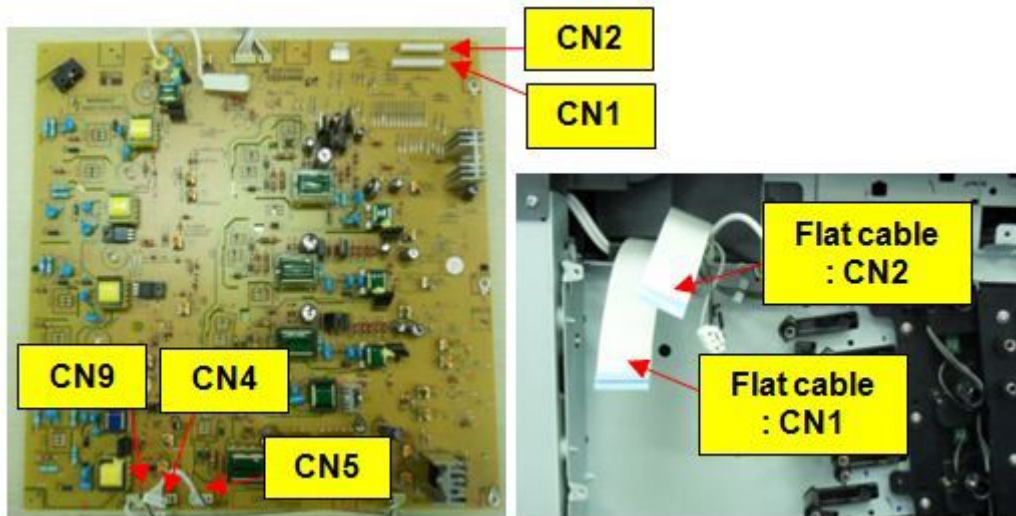

- 8) Check if the Actuator-Feed works normally. If the actuator is defective, replace it. If the feed sensor is defective, replace it.

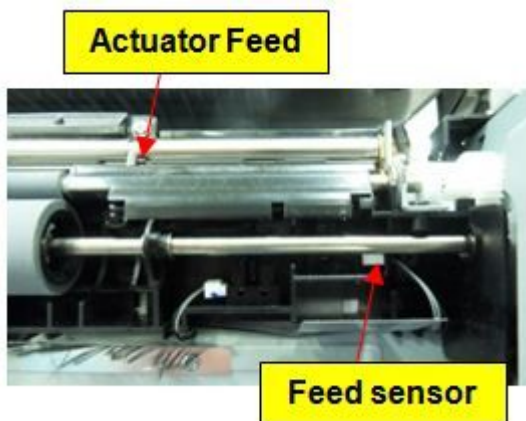

- 9) Check if the Knock up plate in the tray is assembled normally.

▶ **Error Code**

M1-1610

▶ **Error message**

Paper Jam in MP tray.

▶ **Symptom**

A jammed paper has occurred in the MP tray.

▶ **Troubleshooting method**

- 1) If there is the jammed paper in the MP tray, remove it.  
If the problem persists, check the following.
- 2) Check if the MP empty sensor connector is connected properly. Reconnect it.

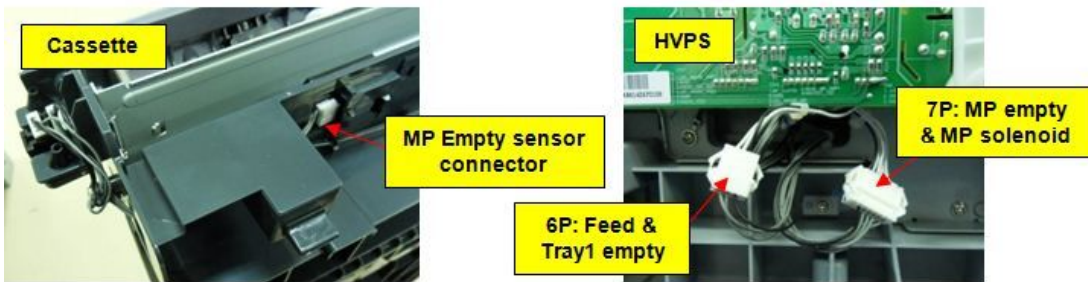

- 3) If the pick up roller doesn't rotate, replace the pick up clutch.

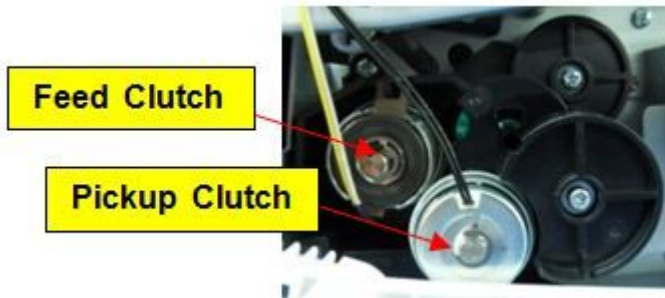

- 4) Check if the Feed sensor and Feed actuator work normally. If these parts are defective, replace it.

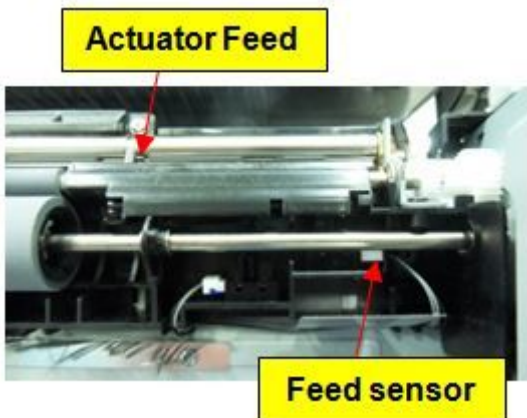

**▶ Error Code**

M1-3122

**▶ Error message**

Tray 1 cassette Out

**▶ Symptom**

Tray 1 cassette is not installed. / Tray 1 cassette is installed but error message is displayed.

**▶ Troubleshooting method**

- 1) Take out the tray 1. Then reinstall it.
- 2) Check if the Feed sensor connector is connected properly. Reconnect it.

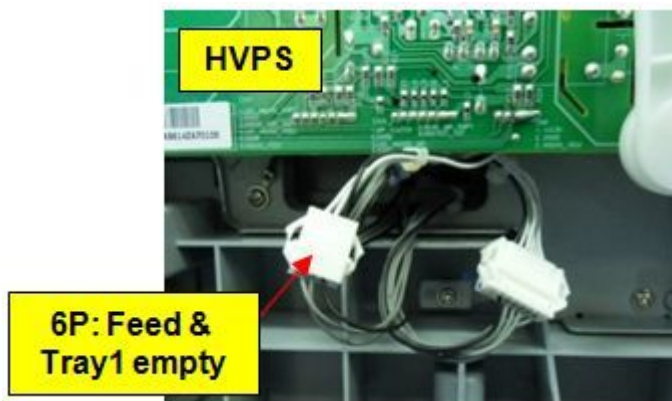

- 3) Check if the Draw connector is connected properly. Reconnect it.

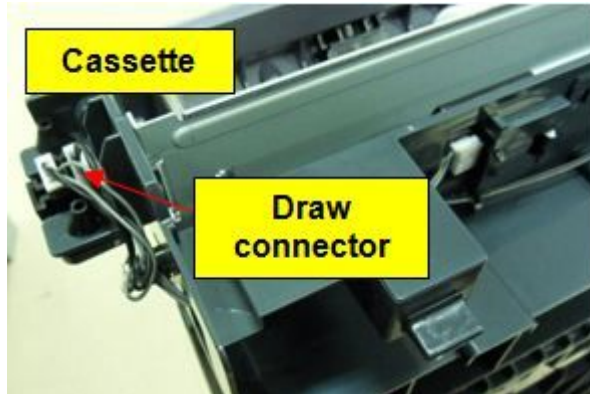

▶ **Error Code**

M1-5112

▶ **Error message**

Paper Empty in tray1.

▶ **Symptom**

Paper is empty in Tray 1 / There is the paper in Tray 1 but error message is displayed.

▶ **Troubleshooting method**

- 1) If there is no paper in tray1, load paper.
- 2) Check if the Paper empty sensor connector is connected properly.
- 3) If the Paper empty sensor is defective, replace it.
- 4) Check if the Paper empty actuator is assembled correctly and work normally. If it is defective, replace it.

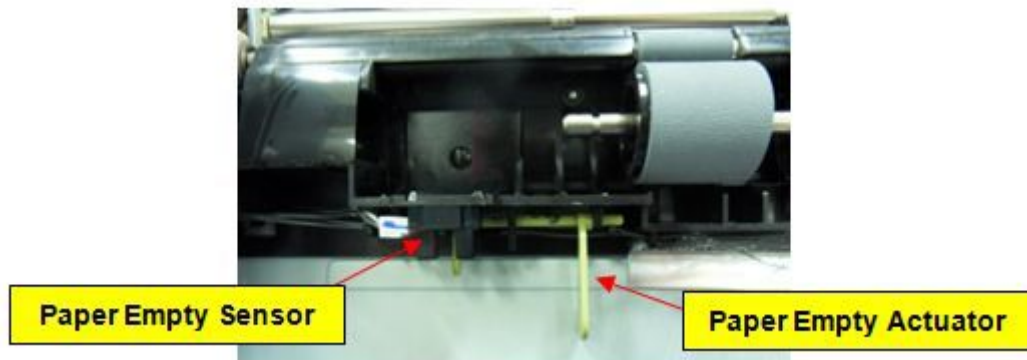

► **Error Code**

M1-5612

► **Error message**

Paper Empty in MP

► **Symptom**

Paper is empty in MP Tray / There is the paper in MP Tray but error message is displayed.

► **Troubleshooting method**

- 1) Check if the MP paper empty sensor connector is connected properly.

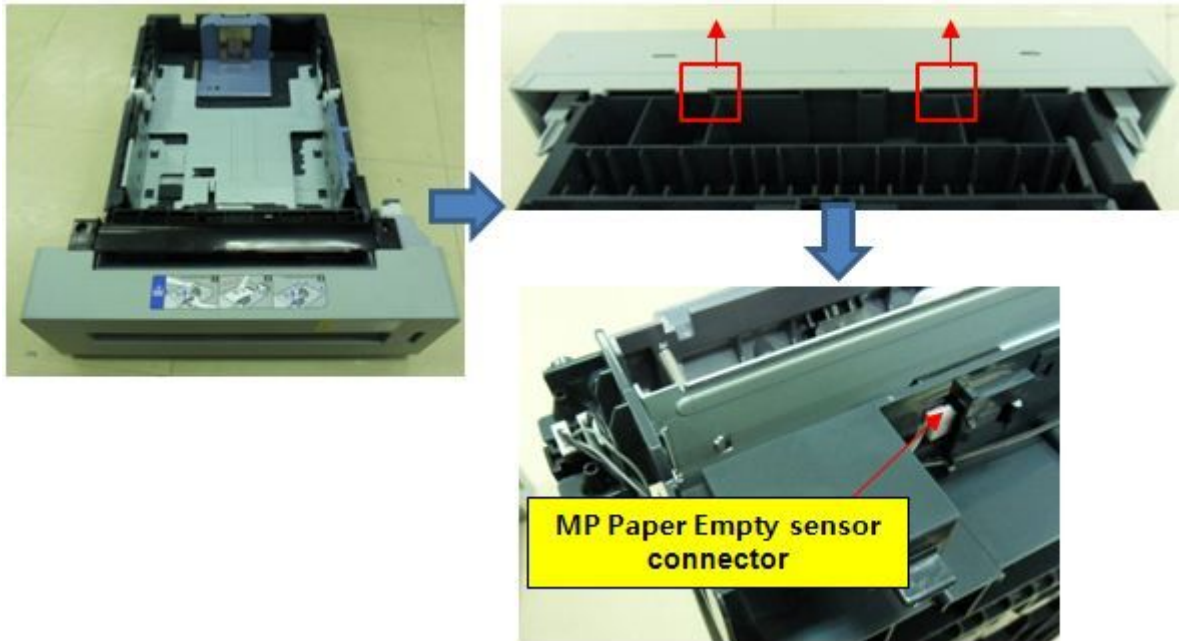

- 2) If the MP paper empty sensor is defective, replace it.

- 3) Check if the MP empty actuator is assembled correctly and work normally. If it is defective, replace it.

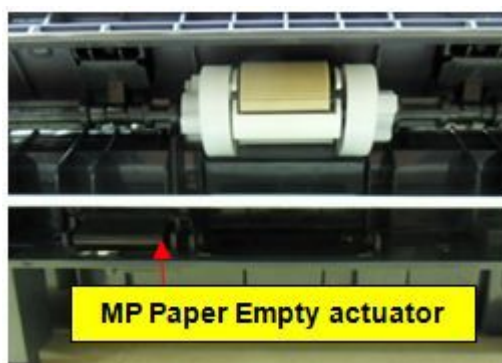

▶ **Error Code**

M2-1110

▶ **Error message**

Jam inside machine.

▶ **Symptom**

Paper jammed in the feeding area of the tray.

▶ **Troubleshooting method**

First, remove the jammed paper. If the problem persists after removing jammed paper, check the followings.

- 1) Check the Spring tension of the Regi. roller and Regi shaft. If the spring is defective, replace it.
- 2) Reconnect the flat cable / exit sensor harness / Feed sensor harness.

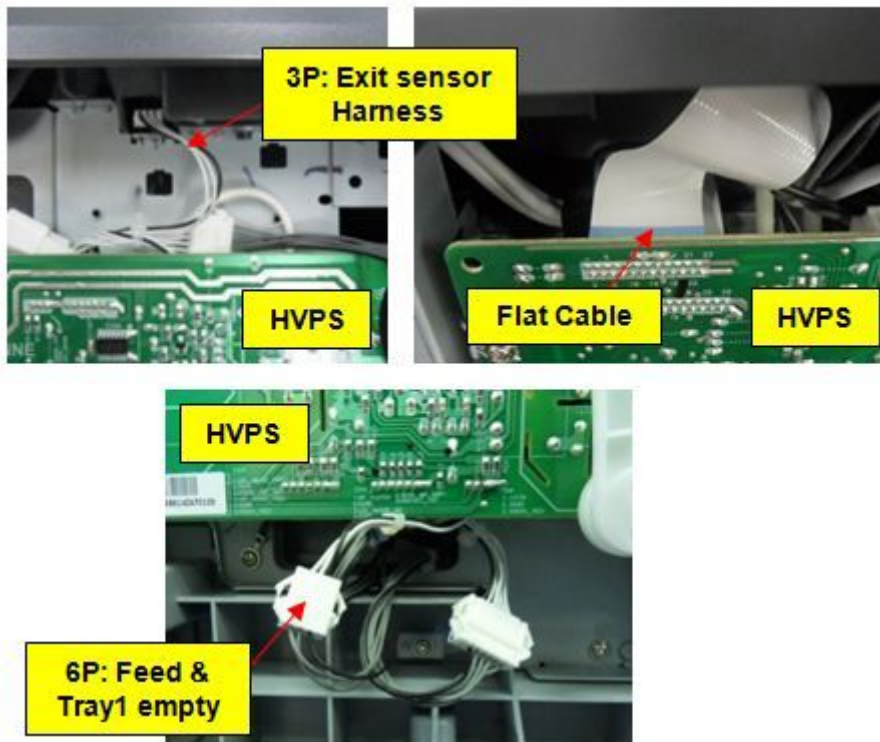

- 3) If the connection is OK, check the actuator fuser and exit sensor. If there is a defect, replace the defective part.
- 4) Check if the OPC motor is working normally. If the OPC motor is defective, replace it.
- 5) Check if the belt of the PTB is torn. Replace the PTB unit.



**▶ Error Code**

M2-2310

**▶ Error message**

Jam bottom of duplex.

**▶ Symptom**

Paper jammed in the duplex area.

**▶ Troubleshooting method**

- 1) Open the front cover and separate the PTB unit. Remove the jammed paper.
- 2) If the paper is not reached to the duplex path after the exit sensor sensing, check the Clutch-BK deve. If it is defective, replace it.



- 3) Check if the Exit actuator work normally. Check if the actuator spring is assembled correctly.

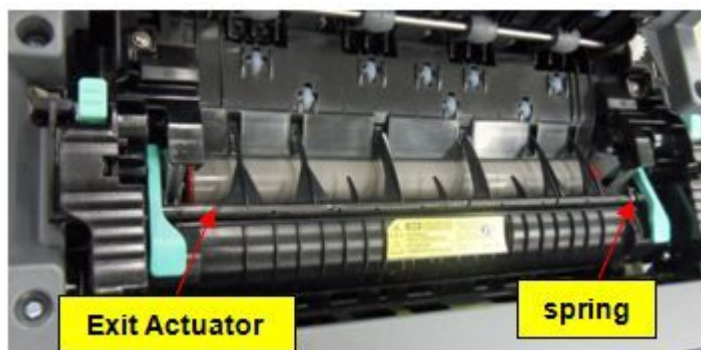

- 4) Check if the fuser motor rotate in reverse when the paper is entering to the machine for duplex printing.

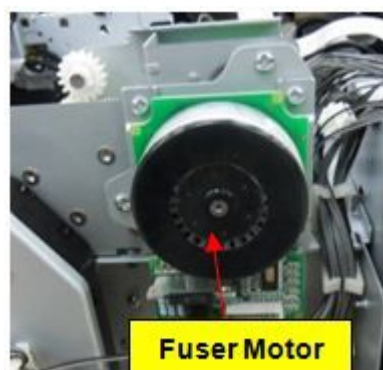

▶ **Error Code**

M3-1110

▶ **Error message**

Jam in exit area

▶ **Symptom**

Paper jammed in the exit area.

▶ **Troubleshooting method**

- 1) Remove the jammed paper from the exit area.
- 2) Check if the flat cable and exit sensor connectors are connected correctly. Reconnect it.

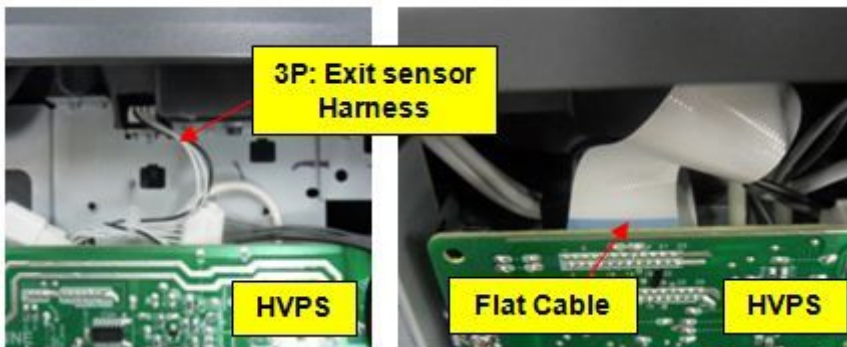

- 3) Check if the fuser actuator and exit sensor work normally. If there are any defective parts, replace it.

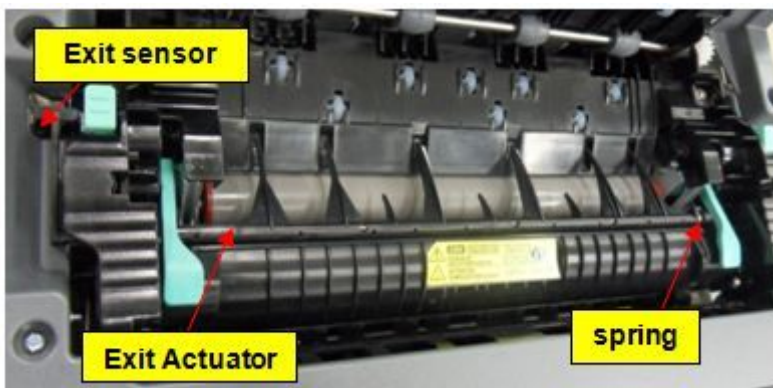

**▶ Error Code**

M3-2130

**▶ Error message**

Output bin full / Output bin full. Remove printed paper.

**▶ Symptom**

The paper is full on the output bin. / The outbin full sensor is defective.

**▶ Troubleshooting method**

- 1) Remove the paper on the output bin.
- 2) Check if the CN3 connector on Main board is connected correctly.

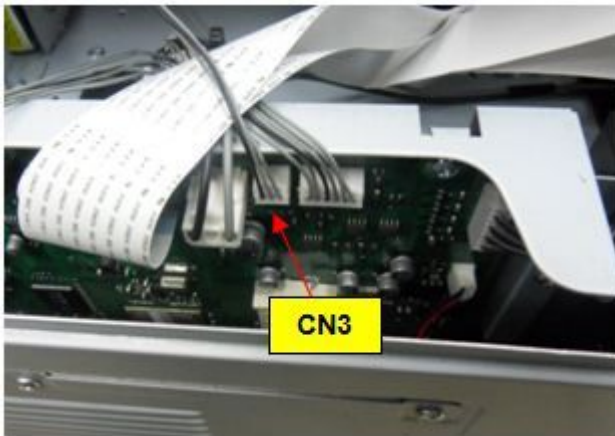

- 3) Check if the Actuator-Stacker, Actuator-OutFull, and Bin-full sensor work normally. Check if the Bin-full sensor connector is connected correctly. If there are any defective parts, replace it.

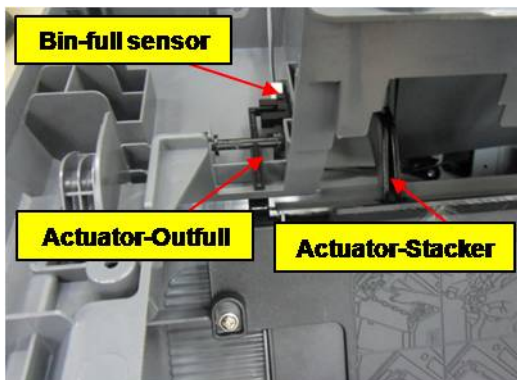

▶ **Error Code**

S2-1523

▶ **Error message**

Error: #S2-1523 / Engine System Failure: #S2-1523. Turn off then on.

▶ **Symptom**

The LPEC chip on main board does not work normally.

▶ **Troubleshooting method**

- 1) First, turn the machine off then on.
- 2) If the problem persists, replace the main board.

▶ **Error Code**

S2-4121

▶ **Error message**

Door is open or Check Transfer belt.

▶ **Symptom**

Front cover or Top cover is open.

▶ **Troubleshooting method**

- 1) Close the front cover and top cover perfectly.
- 2) If the PTB unit is not installed, install it.
- 3) Check the cover switch harness between the main board and HVPS board.

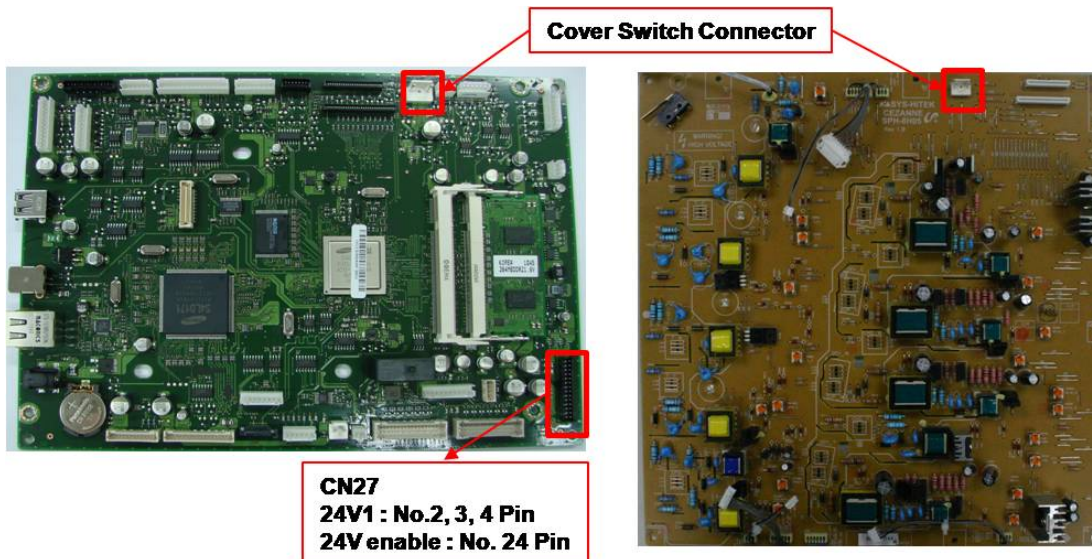

- 4) Check the 24V enable signal on the main board. If the voltage is high (5V), replace the main board.
- 5) If the problem persists, replace the SMPS board.

**▶ Error Code**

S6-3123

**▶ Error message**

IP Conflict / This IP address conflicts with that of other system.

**▶ Symptom**

IP address conflicts with that of other system.

**▶ Troubleshooting method**

Change the machine's IP address.

**▶ Error Code**

S6-3128

**▶ Error message**

IP Conflict / This IP address conflicts with that of other system.

**▶ Symptom**

Can not get the authentication from server after setting up to 802.1x on SWS. Can not access to network.

**▶ Troubleshooting method**

Check if the Authentication method is selected properly.  
Check if the User Name/Password is entered properly.

**▶ Error Code**

U2-6133

U2-6134

**▶ Error message**

Error: #U2-6133 / LSU Unit Failure: #U2-6133. Turn off then on.

Error: #U2-6134 / LSU Unit Failure: #U2-6134. Turn off then on.

**▶ Symptom**

LSU motor does not work normally.

**▶ Troubleshooting method**

※ First, turn the machine off then on. If the error persists, refer to the following.

- 1) Check LSU motor operation sound.
- 2) If there is no sound, check that LSU connector is connected correctly.
- 3) If the connection is OK, replace the LSU.
- 4) If the problem persists, replace the main board.

▶ **Error Code**

U2-6142

U2-6143

▶ **Error message**

Error: #U2-6142 / LSU Unit Failure: #U2-6142. Turn off then on.

Error: #U2-6143 / LSU Unit Failure: #U2-6143. Turn off then on.

▶ **Symptom**

LSU H sync signal is abnormal.

▶ **Troubleshooting method**

※ First, turn the machine off then on. If the error persists, refer to the following.

- 1) Check if the LSU connector on the main board is connected correctly.
- 2) If the connection is OK, replace the LSU.
- 3) If the problem persists, replace the main board.

### 4.2.3. Image quality problems

#### 1) Vertical Black Line and Band

- Description
  - a) Straight thin black vertical line occurs in the printed image.
  - b) Dark black vertical bands occurs in the printed image.

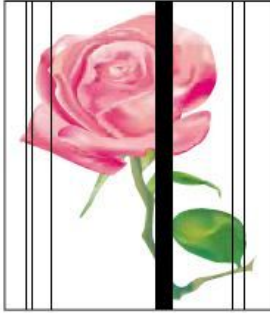

Cause and Check Point	Solution
Check if the surface of the charge roller is scratched or contaminated.	Replace the toner cartridge and test again.
Check if there are grooves on the circumference of the OPC drum.	Replace the toner cartridge and test again.
Check if the cleaning blade is damaged	Replace the toner cartridge and test again.
Is the charge roller of PTB unit damaged?	Clean the charge roller of PTB unit, or replace the PTB unit.
Check if paper transfer belt is damaged or contaminated.	Replace the PTB unit and test again.

#### 2) Vertical White Line

- Description : White vertical voids in the image.



Cause and Check Point	Solution
Check if the LSU window or internal lenses of LSU is contaminated.	Clean the LSU window with recommended cleaner(IPA). Clean the window with a clean cotton swab. If dirt is inside the LSU, replace the LSU.
Check if there are scratches on the circumference of the OPC drum.	Replace the toner cartridge.
Check if there are scratches on the circumference of the developing roller.	Replace the toner cartridge.
Foreign objects inside the toner cartridge.	Replace the toner cartridge.
Check if there are vertical scratches on the transfer unit.	Replace the PTB unit.

3) **Contamination on back of page**

- Description : The back of the page is contaminated.

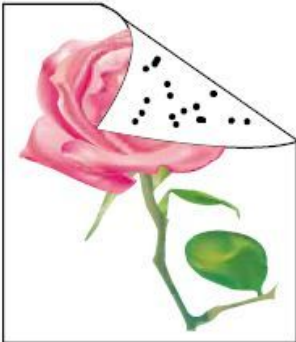

Cause and Check Point	Solution
Dirty registration roller, pressure roller, feed roller, etc. Any dirty rollers through the path of the paper.	Identify the roller which may cause the problem by comparing the period of the contamination on images with the size of rollers. Clean any dirt from the roller or replace the dirty roller.
Dirty PTB belt or damaged PTB belt.	Clean PTB or replace the PTB unit.
Dirty feed guide, or any paper delivery guide.	Clean the part which cause the contamination.

4) **Dark or Black image**

- Description : The black page is printed out.



Cause and Check Point	Solution
No charging voltage in the HVPS.	Check the connecting state between the Main PBA and HVPS. Reconnect the harness.
Poor contact between toner cartridge and set contacts.	Clean the contacts as necessary. Replace any deformed or damaged contacts.
HVPS is defective.	Replace the HVPS.



5) **Blank Page**

- Description : Blank page is printed.

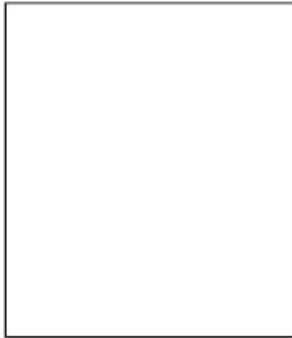

Cause and Check Point	Solution
Bad contacts from OPC drum and/or toner cartridge to ground.	Check the terminal of Ground-OPC.
Not working the LSU.	Check the connector of LSU.
Not working the developing bias voltage on HVPS.	Check the HVPS B'd and replace it.

6) **Uneven Density**

- Description : Print Density is uneven between left and right.



Cause and Check Point	Solution
The pressure force in the left and right springs of the transfer roller is not even, the springs are damaged, the transfer roller is improperly installed.	Replace the PTB Unit
The toner layer is not even in the developing roller due to the damaged blade or low toner level.	Replace the toner cartridge.
Poor the pressure spring force of the toner cartridge.	Replace the toner cartridge.
The life of the Toner Cartridge has expired.	Replace the toner cartridge.

7) **Horizontal Bands**

- Description : Dark or white horizontal stripes appear in the page. (These may occur at regular intervals down the page.)



Cause and Check Point	Solution
The developing roller, OPC drum or other rollers in the toner cartridge may be contaminated or deformed.	Replace the toner cartridge.
Contamination of the Gap-Ring - regular intervals 38.9mm	Clean the gap ring, or replace it. Or replace the toner cartridge
Bad contacts of HV terminals of the toner cartridge with high voltage terminals from printer set.	Clean all HV terminals in the cartridge and on the set frame. Ensure all toner or paper dust, particles are removed.

8) **Poor Fusing**

- Description : Toner is not properly fixed on paper.

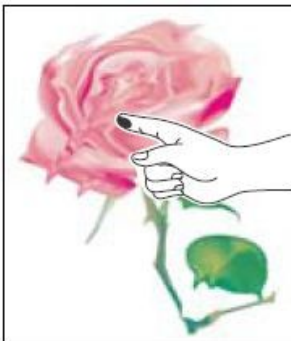

Cause and Check Point	Solution
The media doesn't meet specification	Use the proper media in specifications.
Fuser is defective	Replace the fuser unit.
FDB (Fuser drive board) is defective.	Replace the FDB.

#### 4.2.4. Other errors

##### 1) Multi-Feeding

- Description : Multiple sheets of paper are fed at once.

Cause and Check Point	Solution
Pick up solenoid or feed clutch is defective.	Replace the solenoid or clutch.
Pick up roller and friction pad are contaminated.	Clean the contaminated roller with soft cloth with Isopropyl Alcohol.

##### 2) No power

- Description : When system power is turned on, the printer does not warm up or LCD panel is blank.

Cause and Check Point	Solution
Check that the power code is plugged into electrical outlet.	Plug the power code.
The power input and SMPS output are abnormal.	Replace the SMPS.
LCD panel is defective.	1) Replace the LCD panel 2) If the problem persists, replace the OPE board.

# 5. System Diagram

## 5.1. Block Diagram

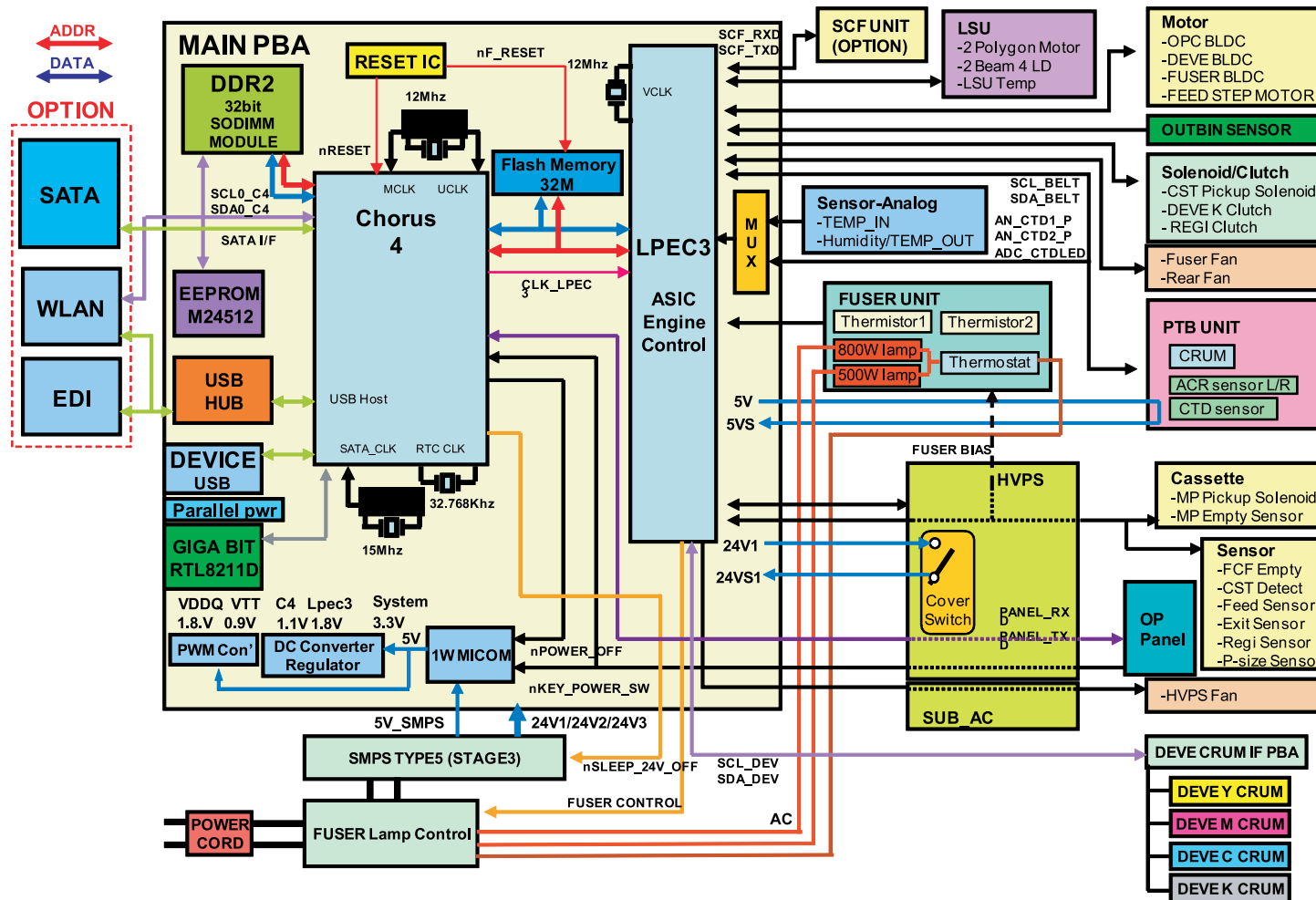

## 5.2. Connection Diagram

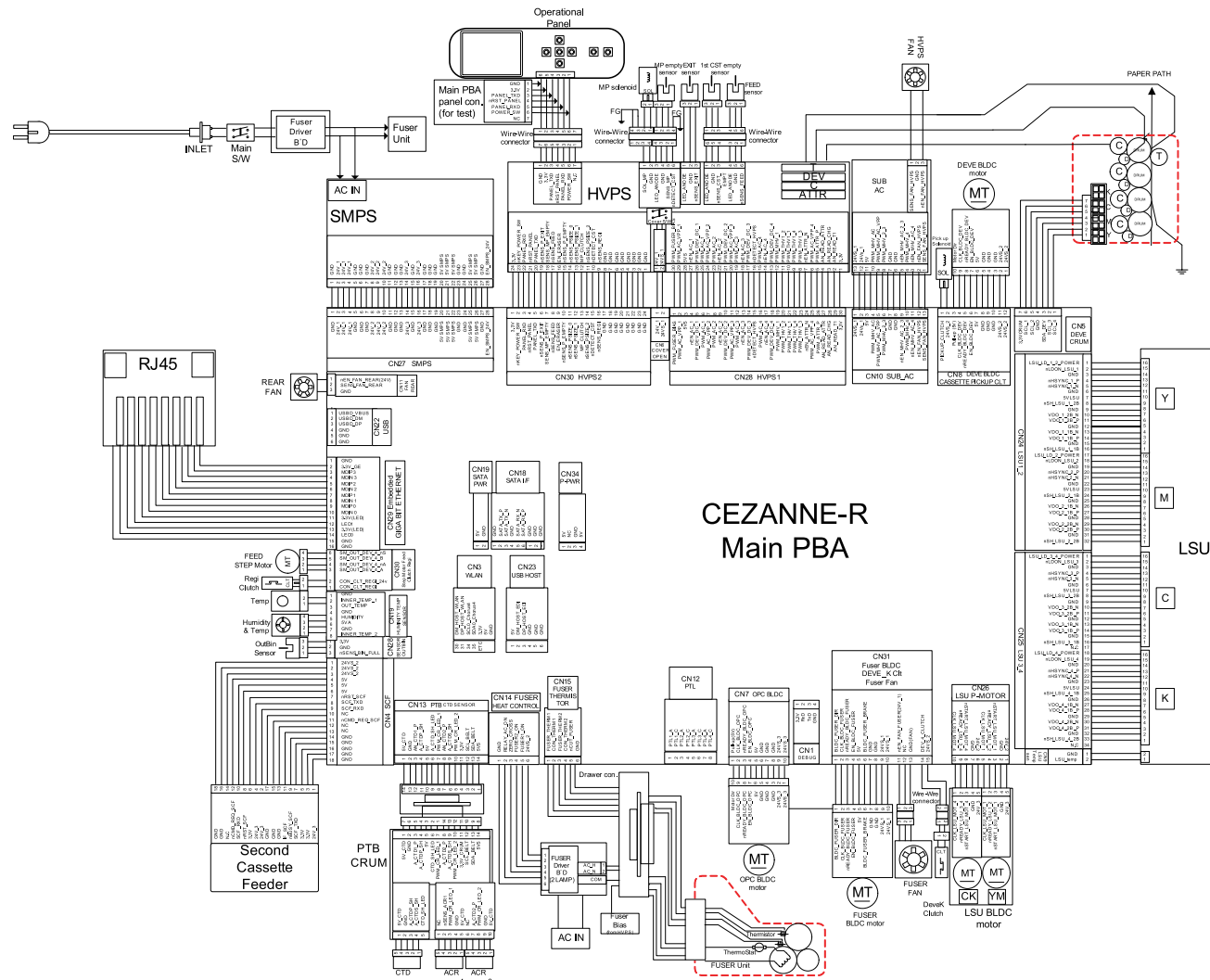





## 6. Reference Information

This chapter contains the tools list, list of abbreviations used in this manual, and a guide to the location space required when installing the printer. A definition of test pages and Wireless Network information definition is also included.

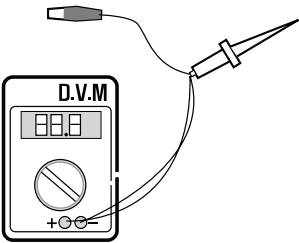
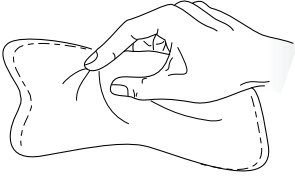
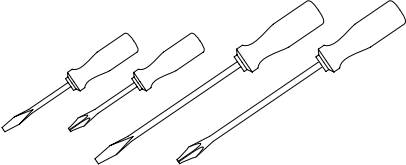
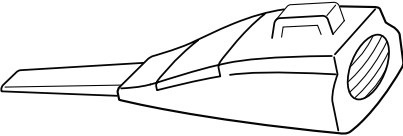
### 6.1. Tool for Troubleshooting

The following tools are recommended safe and easy troubleshooting as described in this service manual.

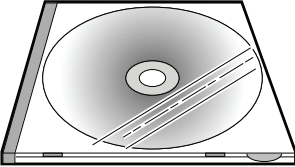
<p><b>DVM (Digital Volt Meter)</b> Standard : Indicates more than 3 digits.</p> 	<p><b>Cleaning Equipments</b> Standard : An IPA (Isopropyl Alcohol) dry wipe tissue or a gentle neutral detergent and lint-free cloth.</p> 
<p><b>Driver</b> Standard : “-” type, “+” type (M3 long, M3 short, M2 long, M2 short).</p> 	<p><b>Vacuum Cleaner</b></p> 
<p><b>Tweezers</b> Standard : For general home use, small type.</p> 	<p><b>Spring Hook</b> Standard : For general use</p> 
<p><b>Cotton Swab</b> Standard : For general home use, for medical service.</p> 	<p><b>Software (Driver) installation CD ROM</b></p> 

## 6.2. Acronyms and Abbreviations

The table below explains abbreviations used in this service manual.

The contents of this service manual are declared with abbreviations in many parts. Please refer to the table.

### 6.2.1. Acronyms

ABS	Automatic Background Suppression(a kind of copy feature)	FDI	Foreign Device Interface
		FIA	Foreign Interface Attachment
APF	Automatic Paper Feeder(Tray)	FRU	Field Replaceable Unit
BOOTP	BOOTSTRAP PROTOCOL	FPOT	First Print Out Time
CCD	Charged Coupled Device	GW	GateWay
CIS	Contact Image Sensor	HH	High Temperature, High Humidity(Testing Chamber conditions)
CPM	Copies Per Minute		
CP	Control Panel(= OPE)	HPVC	Halftone Printing Video Controller in the SPGPm (Graphic Processor for Copy)
CQ	Copy Quality		
CRU	Customer Replaceable Unit	IDC	International Data Corp.
CRUM	CRU Memory	IMAP	Internet Message Access Protocol
CW	Center Ware	IPP	Internet Printing Protocols
CWDP	Center Ware Device Discovery Software(Samsung equivalent of Samsung's SyncThru)	IPM	Images Per Minutes
		IPX	Internetwork Packet Exchange
		IQ	Image Quality
CWIS	Center Ware Internet Services	ITU	International Telecommunication Union
DADF	Duplex Auto Document Feeder (= DADH)	JBIG	Joint Binary Image Group (a kind of image data coding method)
DC	Direct Connect	JPEG	Joint Photographic Expert Group (a kind of image data coding method)
DDNS	Dynamic Domain Name System		
DHCP	Dynamic Host Configuration Protocol	LCD	Liquid Crystal Display
DLC	Data Link Control	LEF	Long Edge Feeding
DNS	Domain Name System	LL	Low Temperature, Low Humidity (Testing Chamber conditions)
ECM	Error Correction Mode		
ECP	Enhanced Capability Port	LPR/LPD	Line Printer Daemon Protocols (LPR is a TCP-based protocol)
e-Coil	Extended Coil technology for Rapid(Fast) Fusing.		
EH&S	Samsung Environment, Health, & Safty	LUI	Local User Interface
		MCBF	Mean Copy Between Failure
ESMTP	Extended Simple Mail Transfer Protocol	MDSP	Multiple Document Single Printout
EP	Electro Photography	MFP	Multi-Functional Product
EPC	Electric Pre-Collation	MH	Modified Huffman (a kind of image data coding method)
FCOT	First Copy Out Time		

6. Reference Information

MIB	Management Information Base	RT-OS	Real Time Operating System
MIME	Multipurpose Internet Mail Extensions	RX	Receive
MR	Modified Read (a kind of image data coding method)	S2E	Scan-To-Email
		SAD	Solid Area Density
MMR	Modified and Modified Read (a kind of image data coding method)	SC	Service Call
		SCF	Second Cassette Feeder
MN std	Multi-National Standard	SDSP	Single Document Single Printout
MSOK	Master SOK(System Operation Key)	SDMP	Single Document Multiple Printout
MSO	Mixed Size Original	SDR	Shut Down Rate
MP	Multi Purpose	SEF	Short Edge Feeding
MPBF	Mean Print Between Failure	SIR	Sacrificed(or Standard) Image Reference
MSI	Multi Sheet Input	SOK	System Operation Key
MTBF	Mean Time Between Failure	sRGB	Standard RGB (Color Coordinate System)
MTTR	Mean Time To Repair		
NCP	Network Control Protocol	SNMP	Simple Network Management Protocol
NIC	Network Interface Card	TCP/IP	Transmission Control Protocol/Internet Protocol
NOS	Network Operating System		
NN	Normal Temperature, Normal Humidity (Testing Chamber conditions)	TBC(or tbc)	To Be Confirmed
		TBD(or tbd)	To Be Determined
NSDR	Non-Shut Down Rate(=USDR)	TIFF	(Adobe & Aldus) Tagged Image File Format
NW	Network		
OD	Optical Density	TRIM	Technical Retrofit Interim Maintenance
OHD	On Hook Dial	TTM	Time to Market
OSOK	Optional SOK(System Operation Key)	TX	Transmit
OP	Operational Procedure	UI	User Interface
PCL	Printer Control Language	UMC	Unit Manufacturing Cost
PDF	(Adobe) Portable Document Format	UMR	Unscheduled Maintenance Ratio
PPM	Pages Per Minutes	UPnP	Universal Plug and Play
PQ	Print Quality	USB	Universal Serial Bus
PS/3	PostScript Level-3	USDR	Un-Shut Down Rate(=NSDR)
PVC	Printing Video Controller in the SPGPm(Graphic Processor for Printer)	XCMI	Samsung's Management Information Base
QCD	Quality, Cost, and Delivery	WA	Warranty Action
RCP	Remote Control Panel	W x D x H	Width x Depth x Height



## 6.2.2. Service Parts

ACRONYM	EXPLANATION
ELA HOU-SCANNER ASS'Y	ELA=Electrical Assembly, HOU =Housing
MEA UNIT-COVER PA EXIT ASS'Y	MEA= Mechanical Assembly, PA=Paper
PMO-TRAY EXTENTION MP NE	PMO= Processing Mold MP=Multi-Purpose(Bypass) tray NE=for NEC (common as Samsung Halk printer)
MEC-CASSETTE ASS'Y(LETTER)	MEC = Mechanic Combined unit
COVER-M-FRONT	M=Mold
MPR-NAME/PLATE	MPR= Machinery Press,
UNIT-LSU	LSU =Laser Scanning Unit
SMPS-SMPS(V1)+HVPS	SMPS =Switching Mode Power Supply HVPS =High Voltage Power Supply
ELA-OPC UNIT SET	OPC=Organic Photo-Conductive
ELA HOU-MP ASS'Y	MP =Multi-Purpose (Bypass) tray
PBA MAIN-MAIN	PBA =Printed circuit Board Assembly
PMO-CONNECT PAPER MFP	MFP =Multi-Functional Peripheral
FAN-DC	DC =Direct Current
CBF POWER STITCH GRAY	CBF= Cable Form
MEA UNIT GUIDE CST PA ASS'Y	CST=Cassette(Paper tray), PA=Paper
PBA LIU	PBA =Printed circuit Board Assembly LIU =Line Interface Unit for FAX
SHIELD-P_MAIN LOWER	P=Press
CBF HARNESS-LIU GND	LIU =Line Interface Unit for FAX GND= Ground
PMO-COVER FEED AY	AY=Assembly
PMO-COVER BRKT MOTER	BRKT=Bracket
CBF HARNESS-LSU	LSU =Laser Scanning Unit
IPR-SHIELD SMPS UPPERI	IPR=Iron Press
PMO-BUSHING P/U.MP	P/U=Pickup MP=Multi-Purpose (Bypass) Tray
PMO-HOLDER GEAR TRr	TR= Transfer Roller
SPRING ETC-TR_L	TR_L=Transfer Roller - Left
PMO-CAM JAM REMOVE	PMO-CAM= Processing Mold-CAM
PMO-LOCKER DEVE	DEVE=Developer
SPECIAL SCREW(PANNEL MFP)	MFP =Multi-Functional Peripheral
A/S MATERAL-DUMMY UPPER ASS'Y	A/S=After-Service
MCT-GLASS ADF	MCT= Machinery Cutting ADF=Automatic Document Feeder
PPR-REGISTRATION EDGE(F)	PPR= Processing Press
IPR-HOLDER GLASSI	PR=Iron Press

6. Reference Information

ACRONYM	EXPLANATION
MCT-GLASS SCANNER(LEGAL)	MCT= Machinery Cutting
CBF HARNESS-OPE	OPE=Operation Panel(Control Panel)
PBA SUB-D_SUB	PBA SUB-D_SUB =>Sub Printed circuit Board Assembly for the D-SUB type electrical connector (D-Sub) a kind of the connector type(shape 'D')
COVER-M-CCD CABLE	M=Mold CCD=Charge Coupled Device
COVER-SCAN LOWER(UMAX)	UMAX=> Supplier's name for CCD module
ICT-INSERT SHAFTI	ICT= Iron Cutting
IPR-BRK SCAN BD	IPR=Iron Press BRK=Bracket BD= Board
CBF SIGNAL-CCD FFC	CCD = Charge Coupled Device FFC =Flexible Flat Cable
COVER-M-OPE	M=Mold OPE=Operation Panel(Control Panel)
KEY-M-COPY	M=Mold
PLATE-M-ALPHA KEY	M=Molde ALPHA=Alphabet
PMO-GUIDE DP SIDE	DP=Duplex
RING-CS	CS= Compress
GEAR-MP/DUP DRV	MP =Multi-Purpose (Bypass) tray DUP DRV = Duplex Driver
IPR-BRKT G DUPI	PR=Iron Press BRKT=BRACKET G= Ground UP=Duplex
PMO-BUSHING TX(B4)	TX=Transmit
PMO-TRAY CASE, MP	MP=Multi-Purpose tray(Bypass tray)
SPRING CS RE	CS=Compress RE=Rear
SPRING CS FR	CS=Compress FR=Front
PMO-BUSHING FINGER, F	F=Front
ICT-SHAFT-EXIT LOWER ID	ID=Idler
SPRING-EXIT ROLL FD	FD=Face Down
PMO-BUSHING_P/U,MP	P/U=Pickup MP =Multi-Purpose (Bypass) tray
PMO-HOLDER CAM MPF	MPF=Multi-Purpose Feeder(=MP)
PMO-GEAR P/U MPF	P/U=Pickup
MFP =Multi-Functional Peripheral	
RPR-RUBBER PICK UP,MP	RPR=Rubber Press

ACRONYM	EXPLANATION
PBA SUB-MP SEN	PBA SUB-MP-SEN =>Sub Printed circuit Board Assembly for the MP-SEN(= Multi-Purpose (Bypass) tray-Sensor)
A/S MATERIAL-PICKUP,MP	
FOOT-ML80	
HOLDER CATCH CST MC2	MC2=>McKinley2 (Samsung Project code name)
ELA M/M-AUD SPEAKER	ELA M/M => Electrical Assembly M/M AUD=Audio
CBF HARNESS-OPC GND	OPC GNG=Organic Photo-Conductive-Ground
IPR-GROUND PLATE SCF	SCF=Second Cassette Feeder(Tray2)
PBA SUB-PTL	PBA SUB-FEED=>Sub Printed circuit Board Assembly for the feeder EMP SEN=Empty Sensor
MOTOR STEP-MCK2(MAIN)	
GEAR-EXIT/U	EXIT/U=EXIT/Upper
GEAR-RDCN FEED INNER	RDCN=Reduction
CBF-HARNESS-MAIN-THV WIRE	THV =Transfer High Voltage
CBF-HARNESS-MAIN-MHV WIRE	MHV= High Voltage(Charge Voltage)
GEAR-EXIT/U,ID	U=Upper ID=Idler
IPR-TERMINAL FU	FU=Fuser
PMO-BEARING H/R-F	H/R-F=Heat Roller - Front
BEARING-H/R L	H/R-L=Heat Roller -Left
PEX-ROLLER EXIT F_UP	PEX= Processing Extrude F_UP=Face Up
SPRING ETC-P/R	P/R=Pressure Roller
SPRING(R)-CAU-HOT-FU	CAU-HOT-FU = Caution Hot -Fuser
PMO-ARM ACTUATOR	PMO-ARM= Processing Mold Arm
LABEL(R)-HV FUSER	HV=High Voltage (220V)
LABEL(R)-LV FUSER	LV=Low Voltage (110V)
PPR-SPONG SHEET	PPR=Plastic Press
IPR-P_PINCH(SCAN)I	PR-P = Iron Press
ROLLER-REGI	REGI=Registration
PBA SUB-REGI	PBA SUB-REGI => Sub Printed circuit Board Assembly for the Registration
GROUND-P_SCAN ROLLER	GROUND-P =Ground-Press
IPR-GUARD C/O S/W	C/O = Cover Open S/W= Switch
MEA UNIT-TX STACKER	TX =Transmit
IPR-WASHER SPRING CU	CU=Curve

# 6.3. The Sample Pattern for the Test

The life of the toner cartridge and the printing speed are measured using the pattern shown below.

## 6.3.1. A4 ISO 19798 Standard Pattern

Stephen J. Siegel  
Falsus Siqua Aharum  
Totus, ESE  
URANGLE

30 November 2005

Johannes Q. Maeria  
Iuper Marpen Aharum  
243 Sauria Ducer Laak  
Brahic, SIE

M. Maeria

Nam liber tempus cum voluta nobis eleifend picon eoque nihil consequat, vel illum. Dolor et zill fongit nulla voluta et non eros accumsan et nisi nisi digno cum qui blandi gravida lacus et i dicitur et ut aliquip et ea comodo consequat. Duis atque vel cum sine dicit in hendrerit dicitur: veli euse mullerit faucibus et laoreet dicit magna aliquam erat volutpat. Ut wisi enim at diam, illam, quis auctor viverra tateo ullam corporis quois in ead

**Bar Chart:**

Category	Value
Q	10
S	20
D	30
E	40

Stephen J. Siegel  
Despecta Amicissimum  
Falsus Siqua Aharum  
SIE.dog

### Ve Emerirre Et Tum Ober

14 December 2004 MCLLVIII

**>Lorem**  
Nullam ut lorem. Sed volutpat leo ut amet elit. Maecenas mi, dignibus nec, pharetra in, eleifend vel, suscipit. Donec urna. Morbi sit amet tortor. In nulla, ut, sociis volutpat amet. Maec etiam vehit quis est.

**Prasent pellentesque**  
amet. Sed interdum metus non ante. Donec nec risu nec elit lacus et i dicitur.

**Donec ipsum.**  
Vestibulum nec urna. Nullam non enim at nulla faucibus fringilla. Aenean tortor velit, fermentum quis, venenatis a, congue in, purus. Proin ornare, libero eu nulla lacus, nulla massa blandit amet. Sed pulvinar risu metus nec tortor, nulla.

**Nulla mor nare**  
Morbi at sem, Pellentesque risu. Morbi nec nague. Sed fringilla. Donec et leo. Phasellus lacina blandit mi. Etiam eget leo at enim pretium malesuada. Vivamus in losem. Nullam semper tempus losem. Pellentesque et magna. Nunc porta vulut leo. Inque elementum, mi eget tempus vestibulum.

**Consectetur**  
Fusce feugiat metus sed augue. Nunc ligula. Aenean lectus elit, pellentesque ut amet, gravida eget, fringilla non, massa. Vestibulum metus neque, feugiat a, imperdiet id, elementum ac, nunc. Suspendisse tempus. Aliquam vitae eros. Nunc mauris nunc, congue at, volutpat eget, pellentesque et, massa. Nulla vulputate, wisi et consequat gravida, wisi felis socios ante, aliquam consequat lacus eros et alibi. Donec porttitor. libero et lacus sodales, dui fallus id enim elit, eu pulvinar neque losem conubstantum dui. Nam vel quam quis lacus agestis lobortis. Pellentesque posu magna, utrum sed trisda mandt, accumsan ac, ord. In fringilla. Pellentesque rhoncus egestas nunc. Nunc nec nill. Eiam rhoncus, leo, ac vulputate latis perus id ipsum. Proin vestibulum diam quis massa. Nullam enim metus in odio. Duis nill. Curabitur ultram corpor. Cras elit velit, dicitur eget, pharetra ac, curius id, wisi. Mauris maugit justo, vol utpat non, varius. Aliquam vitae ante: Nunc mauris nunc, congue at, scili obitudi dicitur eget.

**Pellentesque rhoncus.**  
est in rutrum faucibus, veli leo volutpat posu, a blandit wisi velit quis est. Donec faucibus eleme ritum mi. In pulvinor elit et amet nill. Donec dolor augue, suscipit nec, nonumy eget, societerique in, est, Integer nill. Aliquam et lacus eget magna societerique blandit. Nullam sapien neque, volutata non, porttitor nec, faucibus et, est. Ut fringilla turpis ut magna porttitor tempus. Praesent amet. Donec sed est consequat ligula pulvinar dignibus. Etiam sapien. Donec a risu ut augue tristique ornare. Fusce bonnet, risu nec egestas nunc, porttitor nec, faucibus et, est. Ut fringilla turpis ut magna porttitor tempus. Praesent amet. Donec sed est consequat ligula pulvinar dignibus. Etiam sapien. Donec a risu ut augue tristique ornare. Fusce bonnet, risu nec egestas nunc, porttitor nec, faucibus et, est. Ut fringilla turpis ut magna porttitor tempus.

**Aliquam et lacus eget**  
magna societerique blandit. Nullam sapien neque, vulputate non, porttitor nec, faucibus et, est. Ut fringilla turpis ut magna porttitor tempus. Praesent amet. Donec sed est consequat ligula pulvinar dignibus. Etiam sapien. Donec a risu ut augue tristique ornare. Fusce bonnet, risu nec egestas nunc, porttitor nec, faucibus et, est. Ut fringilla turpis ut magna porttitor tempus.

**Color Chart:**

Color	Label
Black	Black
White	White
Yellow	Yellow
Cyan	Cyan
Magenta	Magenta
Blue	Blue
Red	Red
Green	Green
Black	Black

**Color Chart:**

Color	Label
Black	Black
White	White
Yellow	Yellow
Cyan	Cyan
Magenta	Magenta
Blue	Blue
Red	Red
Green	Green
Black	Black

**Grayscale Ramp:**

Value	Label
100	100
90	90
80	80
70	70
60	60
50	50
40	40
30	30
20	20
10	10
0	0

### Sempter Fdut Aprioriuis

YF05 YF06 YF07 YF08 YF09

Nuc Facilis:					
Tembo Facilis:	\$ 14,609	\$ 11,592	\$ 9,462	\$ 7,569	\$ 6,484
Interboon Facilis:	17,821	13,650	11,210	9,192	8,192
Tuper Facilis:	32,510	25,350	20,772	16,761	14,494
Bel Repariades:					
Elaber:	27,125	27,380	17,122	13,256	11,880
Sempter:	4,394	3,011	3,105	3,154	2,614
<b>Tuper Yet Repariades:</b>	<b>31,515</b>	<b>24,991</b>	<b>20,317</b>	<b>16,410</b>	<b>14,484</b>

**Repariades et Facilis:**

Facilis zu Portione Eber:	17,669	13,021	10,021	8,518	7,834
Facilis zu Reitor:	2,846	2,478	2,162	1,910	1,780
Reitor et Dicitment:	2,362	2,027	1,761	1,436	1,289
Solg, Gaster et Almad:	5,365	4,925	4,554	3,642	2,491

**Tuper Repariades et Facilis:**

Eberer zorka Orietur:					
Impress Elaber et Obem, Num:	270	29	25	23	20
Impress Repariades:	258	155	121	93	87
Repariades Balome Tarner:	3,632	2,423	1,783	1,334	1,143
Repariades far Taver:	1,139	924	626	523	426
<b>Net Epantiae:</b>	<b>2,433</b>	<b>1,899</b>	<b>1,177</b>	<b>471</b>	<b>647</b>

**Net Epantiae doctores:**

Plan Epantiae:	4,63	9,07	2,53	0,94	1,30
Galgae Dividendum:	0,70	0,55	0,45	0,36	0,32

**Et Hare Sill:**

Tuper Grandem:	\$ 24,627	\$ 19,567	\$ 16,736	\$ 13,700	\$ 11,973
Delpariades:	102,200	96,400	89,200	82,600	89,000
Repariades pen Delpariades:	\$ 508,104	\$ 253,974	\$ 211,195	\$ 177,214	\$ 162,854

**Bar Chart:**

Category	Value
Wisi	10
Ad*	20
Uti	30

### Suscept Lobortis

Adipiscing Enim

**Pie Chart:**

Category	Value
Wisi	10
Ad*	20
Uti	30

**Bar Chart:**

Category	Value
Wisi	10
Ad*	20
Uti	30

**Color Chart:**

Color	Label
Black	Black
White	White
Yellow	Yellow
Cyan	Cyan
Magenta	Magenta
Blue	Blue
Red	Red
Green	Green
Black	Black

### Sempter Balreppens

**Bar Chart:**

Category	Value
Wisi	10
Ad*	20
Uti	30

- Donec citae diam pellenteque sem vitus et ala en luctus semper
- Prasent nulla lacus ultrices quis um toper bine
- Maecenas felis leo posuere quis sagittis pradem
- Pellentesque in dui et sollicitudin dictum etoper

## 6.4. Selecting a location

Select a level, stable place with adequate space for air circulation. Allow extra space for opening covers and trays.

The area should be well-ventilated and away from direct sunlight or sources of heat, cold, and humidity. Do not set the machine close to the edge of your desk or table.

### Clearance space

- Front: 326 mm (enough space so that the paper tray can be removed)
- Back: 100 mm (enough space for ventilation)
- Right: 100 mm (enough space for ventilation)
- Left: 100 mm (enough space for ventilation)

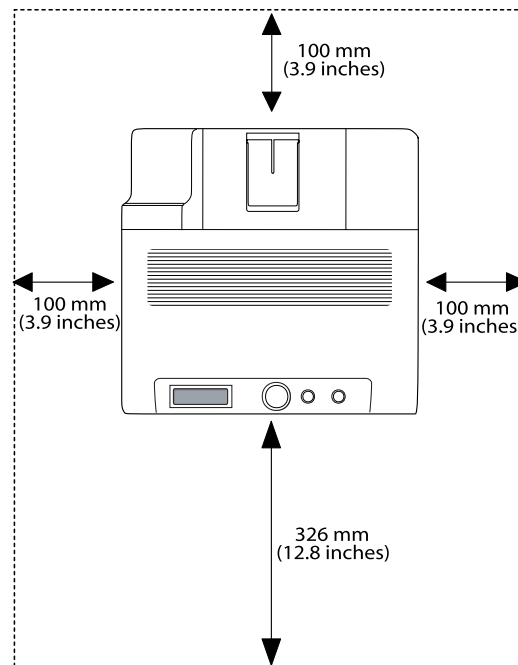



### **GSPN (GLOBAL SERVICE PARTNER NETWORK)**

<b>Area</b>	<b>Web Site</b>
Europe, MENA, CIS, Africa	<a href="https://gspn1.samsungcsportal.com">https://gspn1.samsungcsportal.com</a>
E.Asia, W.Asia, China, Japan	<a href="https://gspn2.samsungcsportal.com">https://gspn2.samsungcsportal.com</a>
N.America, S.America	<a href="https://gspn3.samsungcsportal.com">https://gspn3.samsungcsportal.com</a>

This Service Manual is a property of Samsung Electronics Co.,Ltd.  
Any unauthorized use of Manual can be punished under applicable International and/or domestic law.

© 2016 Samsung Electronics Co.,Ltd.  
All rights reserved.  
Printed in Korea