

1. Main

Exploded View

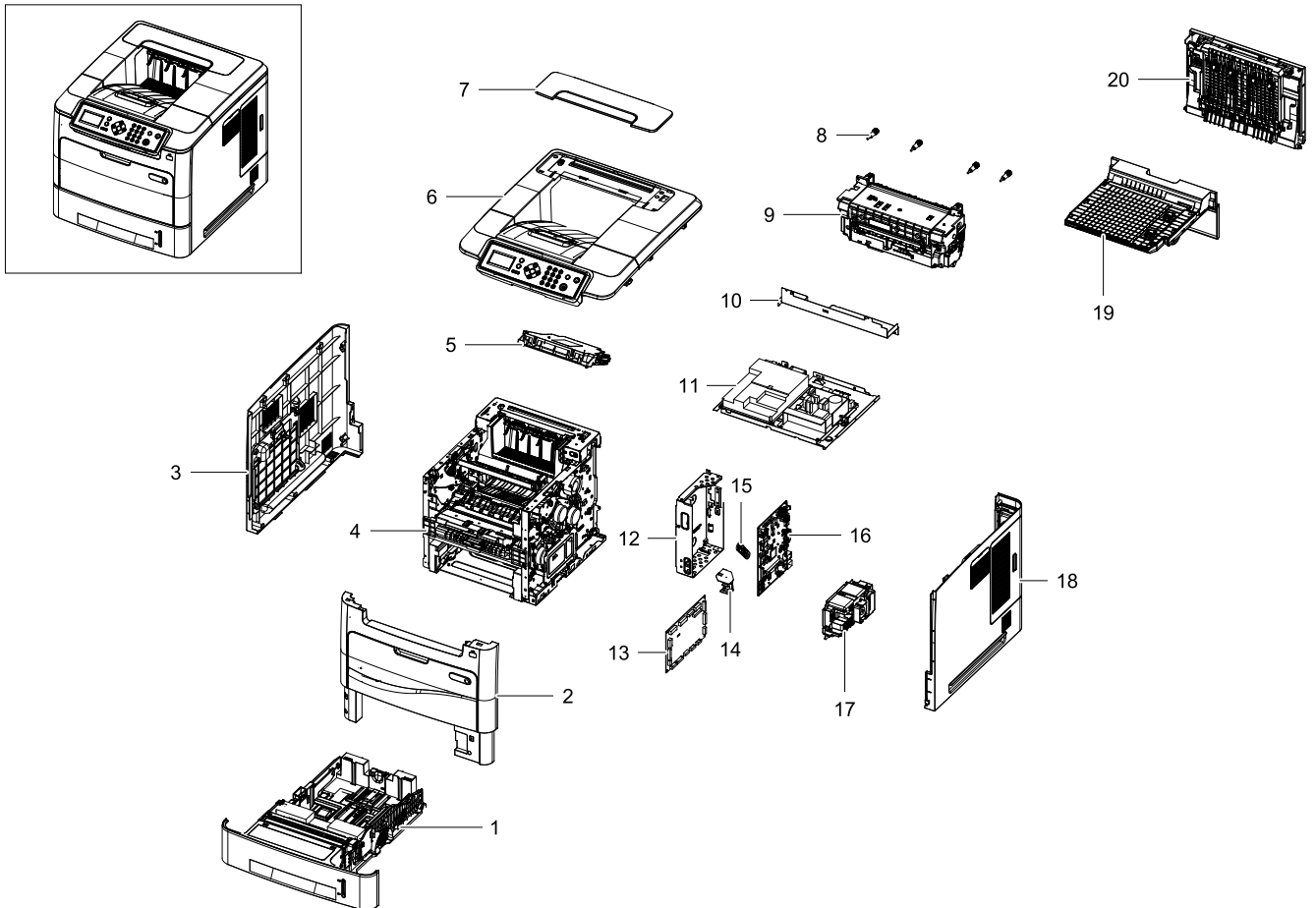

Parts List

No.	Lvl.	Material Code	Description & Specification	SNA	Qty.	Remark
1	1	JC90-01057A	CASSETTE; ML-6510ND,SEC (Wave Type)	SA	1	
2	2	JC95-01296A	COVER-FRONT; ML-6510ND,XAA	SA	1	
3	2	JC95-01299A	COVER-LEFT; ML-6510ND,XAA	SA	1	
4	1	JC93-00241B	FRAME; ML-6510ND,XAA	SNA	1	
5	1	JC97-03777A	LSU; ML-6510ND,SEC,Single,A4(Ltr),600,L2,	SA	1	For ML-6510ND
		JC97-03787A	LSU; ML-5510ND,SEC,Single,A4(Ltr),600,L2	SA	1	For ML-5510ND & 5510N
6	1	JC95-01297*	COVER-TOP	SNA	1	Refer to COVER-TOP section.
7	2	JC95-01322A	COVER-OPTION; ML-6510ND,XAA	SA	1	
8	2	JC64-00186C	HANDLE-M_FIX FUSER; ML-6510ND,PC,14.6,46.	SNA	4	
9	1	JC91-01105A	FUSER; ML-6510ND,SEC,220V	SA	1	For 220V model
		JC91-01104A	FUSER; ML-6510ND,SEC,110V	SA	1	For 110V model

Exploded Views and Parts List

No.	Lvl.	Material Code	Description & Specification	SNA	Qty.	Remark
10	2	JC61-03811A	BRACKET-BOTTOM_FUSER; ML-6510ND,SECC,T1.0	SNA	1	
11	1	JC93-00270B	FRAME-POWER_SUPPLY; ML-6510ND,XRH	SNA	1	
12	2	JC63-02643A	SHIELD-MAIN_CTRL; ML-6510ND,EGI-SECC,0.8,	SNA	1	
13	1	JC92-02281A	PBA-ENGINE; ML-5510ND,SEC,LPEC3,5V/24V	SA	1	
14	2	JC61-03845A	HOLDER-HARNESS_DRIVE; ML-6510ND,PC,W34.8,	SNA	1	
15	2	JC66-02628A	LEVER-COUPLER; ML-6510ND,POM,W21,L89.8,BL	SNA	1	
16	1	JC92-02280B	PBA-MAIN	SA	1	For ML-6510ND
		JC92-02280A	PBA-MAIN	SA	1	For ML-5510ND & 5510N
17	1	JC93-00277B	FRAME-BOARD FUSER DRIVE; ML-6510ND,XRH	SA	1	For 220V model
		JC93-00277A	FRAME-BOARD FUSER DRIVE; ML-6510ND,XRX	SA	1	For 110V model
18	2	JC95-01298A	COVER-RIGHT; ML-6510ND,XAA	SA	1	
19	1	JC90-01018B	DUPLEX; ML-6510ND,SEE	SA	1	
20	2	JC95-01295A	COVER-REAR; ML-6510ND,SEC	SA	1	

2. Cover

Exploded View

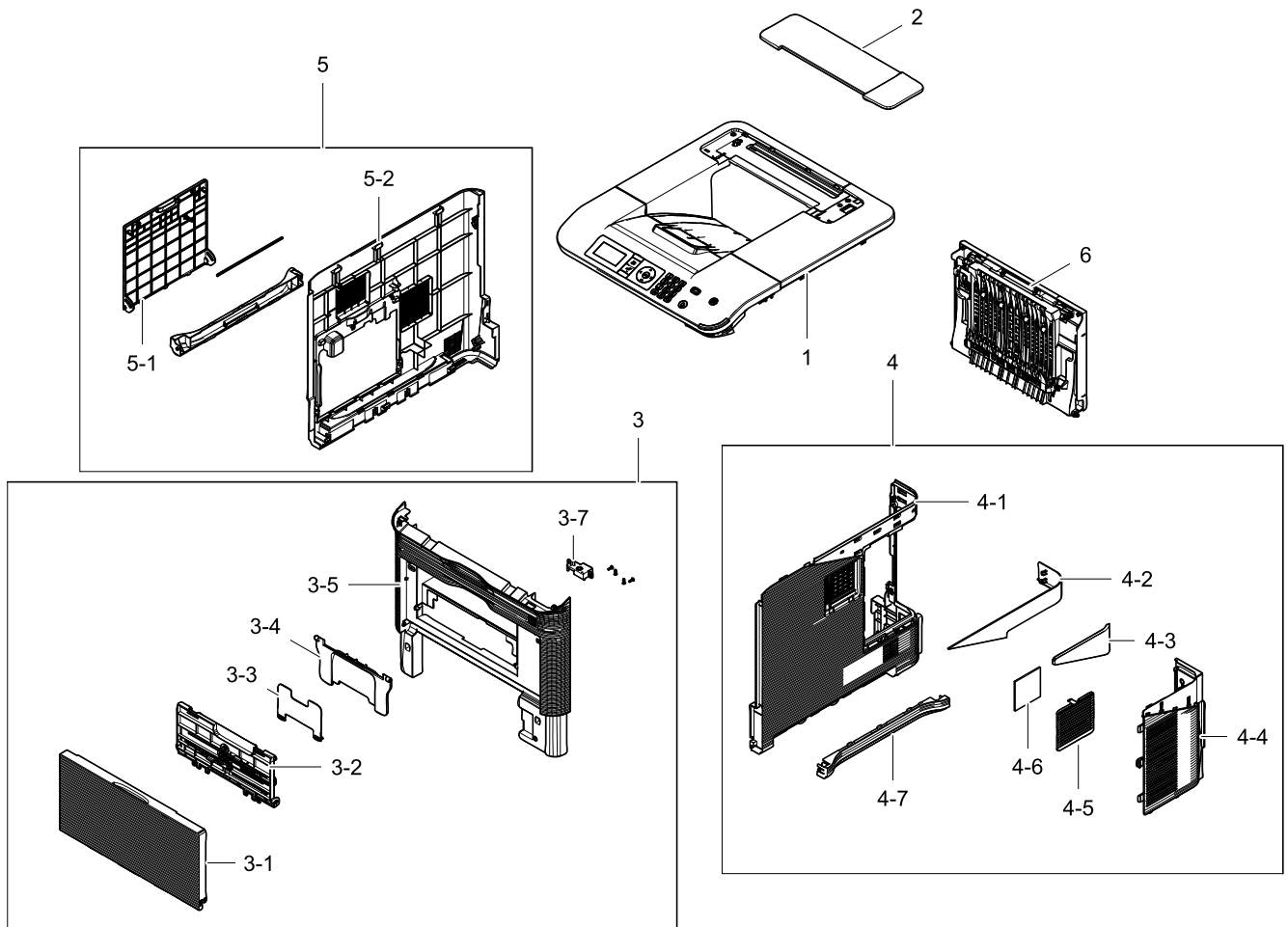

Parts List

No.	Lvl.	Loc.	Material Code	Description & Specification	SNA	Qty.
1	1		JC95-01297A	COVER-TOP; ML-6510ND,XAA	SNA	1
2	2		JC95-01322A	COVER-OPTION; ML-6510ND,XAA	SA	1
3	2		JC95-01296A	COVER-FRONT; ML-6510ND,XAA	SA	1
3-1	3		JC63-02859A	COVER-MP; ML-6510ND,HIPS,2.5,186.3,390.3,	SNA	1
3-2	3		JC90-01016B	MP-TRAY; ML-6510ND,SEC	SA	1
3-3	3		JC61-02804C	STACKER-MP; ML-6510ND,HIPS,120.6,81.4,WAV	SNA	1
3-4	3		JC63-02096C	TRAY-EXTENSION_MP; ML-6510ND,HIPS,2.0,212	SA	1
3-5	3		JC63-02853A	COVER-FRONT; ML-6510ND,HIPS,2.5,227.7,444	SNA	1
3-7	3		JC61-03912A	HOLDER-USB_HOST; ML-6510ND,ABS,2,28.0,47.	SNA	1
4	2		JC95-01298A	COVER-RIGHT; ML-6510ND,XAA	SA	1

Exploded Views and Parts List

No.	Lvl.	Loc.	Material Code	Description & Specification	SNA	Qty.
4-1	3		JC63-02862A	COVER-RIGHT; ML-6510ND,HIPS,2.5,397.2,457	SNA	1
4-2	3		JC63-02863A	COVER-RIGHT_DUMMY; ML-6510ND,HIPS,2.5,40.	SNA	1
4-3	3		JC63-02852A	COVER-CONTROL_BOX DUMMY; ML-6510ND,HIPS,2	SNA	1
4-4	3		JC63-02851A	COVER-CONTROL_BOX; ML-6510ND,HIPS,2.5,174	SNA	1
4-5	3		JC63-02857A	COVER-RIGHT_FAN; ML-6510ND,HIPS,2.5,95.0,	SNA	1
4-6	3		JC62-00759A	SEAL-FILTER RIGHT; ML-6510ND,Polyurethane	SA	1
4-7	3		JC63-02864A	COVER-HANDLE; ML-6510ND,HIPS,2.5,30.9,342	SNA	1
5	2		JC95-01299A	COVER-LEFT; ML-6510ND,XAA	SA	1
5-1	3		JC63-02858A	COVER-WTB; ML-6510ND,ABS,T2.5,W230,L202mm	SNA	1
5-2	3		JC63-02865A	COVER-LEFT; ML-6510ND,HIPS,2.5,397.2,457.	SNA	1
6	2		JC95-01295A	COVER-REAR; ML-6510ND,SEC	SA	1

2.1. Cover Rear

Exploded View

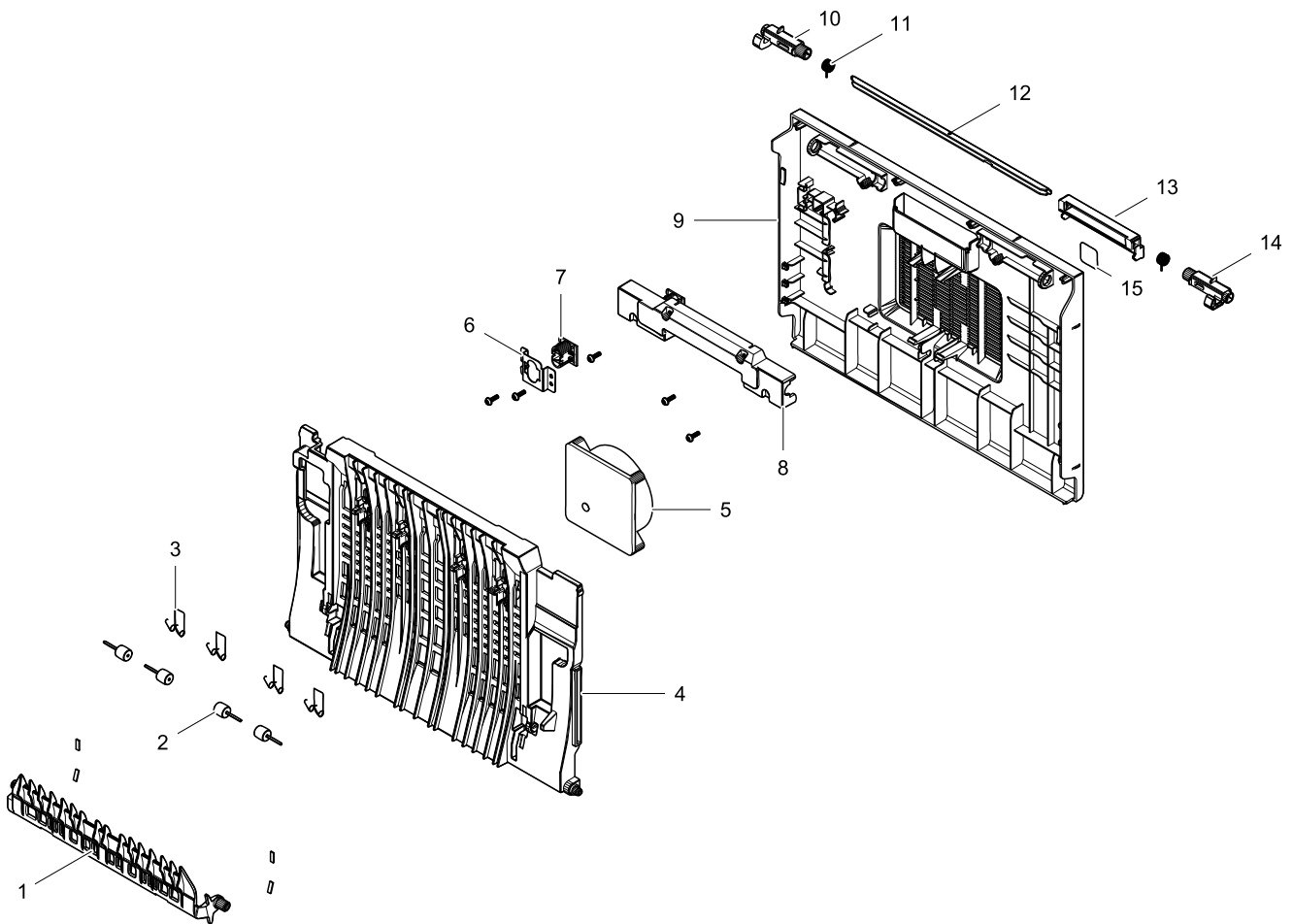

Parts List

No.	Lvl.	Loc.	Material Code	Description & Specification	SNA	Qty.
1	3		JC61-03911A	GUIDE-EXIT; ML-6510ND,PPE+PS,BLACK,PATH	SNA	1
2	3	K6709	JC72-20902A	ROLLER; ML-5000A,PTFE	SA	4
3	3	L7539	6107-001160	SPRING-TS; SUS304,PI0.45,D5.45,L19.8,W14.	SA	4
4	3		JC61-03910A	GUIDE-REAR; ML-6510ND,ABS,BLACK,PATH	SA	1
5	3		JC31-00141A	FAN; D08K-24PU 21B(AX),65g	SA	1
6	3		JC61-02622A	BRACKET-FEMALE; ML-5050ND,SECC,T0.8,W40.7	SNA	1
7	3		JC39-00993A	HARNES-REAR_JOINT_FN; ML-5050ND,UL/CSA,3	SNA	1
8	3		JC61-03909A	HOLDER-LOCKER; ML-6510ND,HIPS,T2.5,W200.1	SA	1
9	3		JC63-02676B	COVER-REAR; ML-6510ND,HIPS,XAA,HB,WAVE GR	SNA	1

Exploded Views and Parts List

No.	Lvl.	Loc.	Material Code	Description & Specification	SNA	Qty.
10	3		JC64-00547A	LOCKER-REAR L; ML-6510ND,POM,BLACK,D-Type	SA	1
11	3	L7529	6107-001268	SPRING-TS; SUS304 WPB,PI0.9,D8.9,L7,ID8.0	SA	1
12	3		JC61-01404A	BRACKET-P-HANDLE SCF; SCX-6345N/XRX,SECC,	SNA	1
13	3		JC64-00420C	HANDLE-REAR COVER; ML-6510ND,ABS,HB	SA	1
14	3		JC64-00548A	LOCKER-REAR R; ML-6510ND,POM,BLACK,D-Type	SA	1
15	3		JC68-02563A	LABEL-FUNCTION; ML-6510ND,XEROX,20,20	SNA	1

3. Cover Top

Exploded View

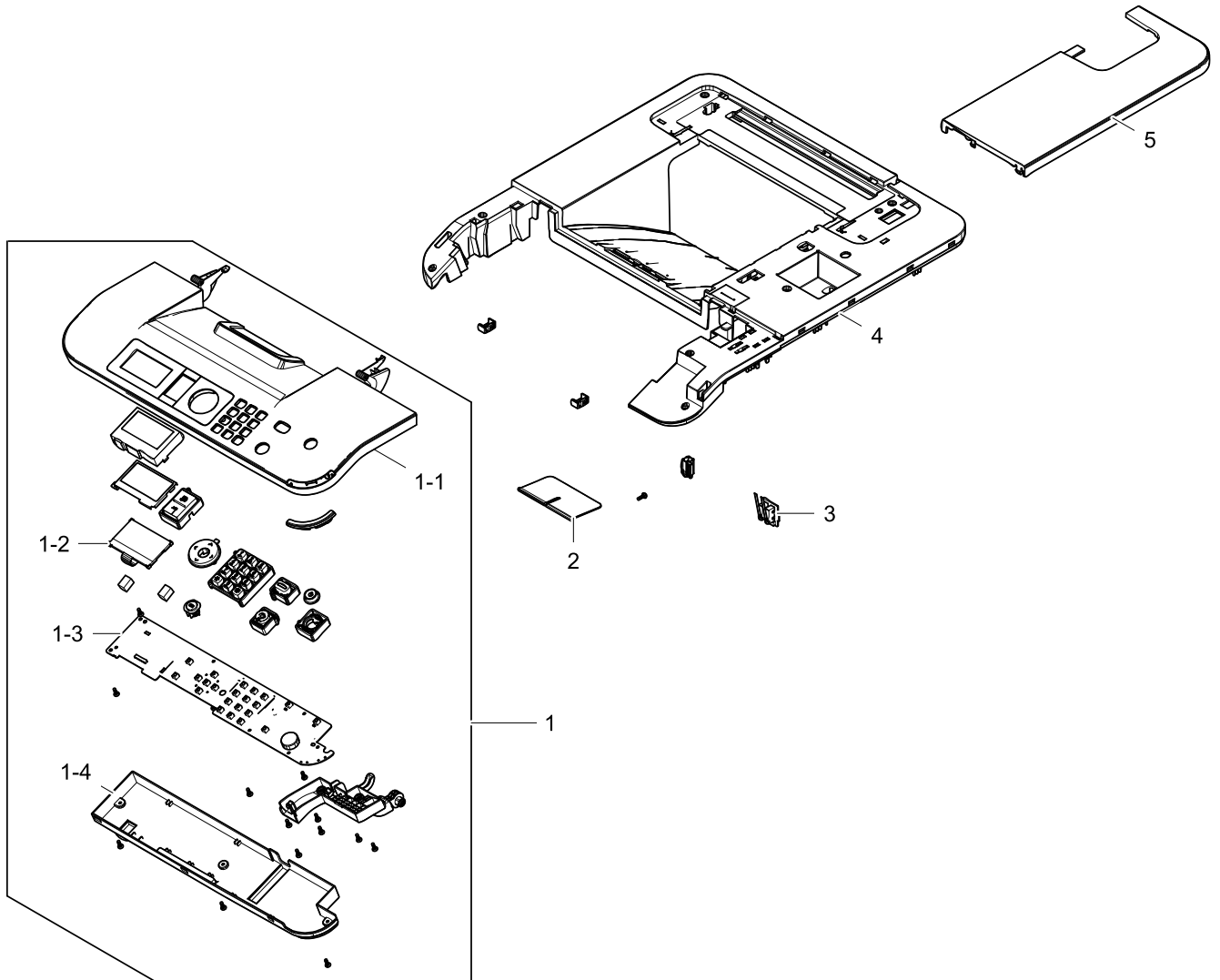

Parts List

No.	Lvl.	Material Code	Description & Specification	SNA	Qty.	Remark
1	2	JC97-03868A	OPE	SA	1	For ML-6510ND
		JC97-03868B	OPE	SA	1	For ML-5510ND
		JC97-03868C	OPE	SA	1	For ML-5510N
		JC97-03868D	OPE	SA	1	For ML-6512ND
		JC97-03868E	OPE	SA	1	For ML-5512ND
		JC97-03868F	OPE	SA	1	For ML-5515ND
		JC97-03868G	OPE	SA	1	For ML-6515ND
1-1	3	JC63-02866A	COVER-OPE; ML-6510ND,ABS,SEC	SNA	1	
1-2	3	JC07-00012A	LCD; VHF12642FL3W,ML-5050ND,128x64 Dots,7	SA	1	

Exploded Views and Parts List

No.	Lvl.	Material Code	Description & Specification	SNA	Qty.	Remark
1-3	3	JC92-02285A	PBA-OPE; ML-5510ND,SEC,S3C828BXZZ-TW8B,5V	SA	1	
1-4	3	JC63-02867A	COVER-OPE_LOWER; ML-6510ND,HIPS,2.5,42.8,	SA	1	
2	2	JC72-01367E	ADJUST; ML-6510ND,ABS,HB,Wave Gray,ADJUST	SA	1	
3	2	JC92-02057A	PBA-COVER_OPEN SENSOR; ML-4050/XRX,XEROX,	SA	1	
4	2	JC63-02860A	COVER-TOP; ML-6510ND,HIPS,2.5,461.0,515.0	SA	1	
5	2	JC63-02861A	COVER-TOP_DUMMY; ML-6510ND,HIPS,2.5,141.6	SA	1	

4. Duplex

Exploded View

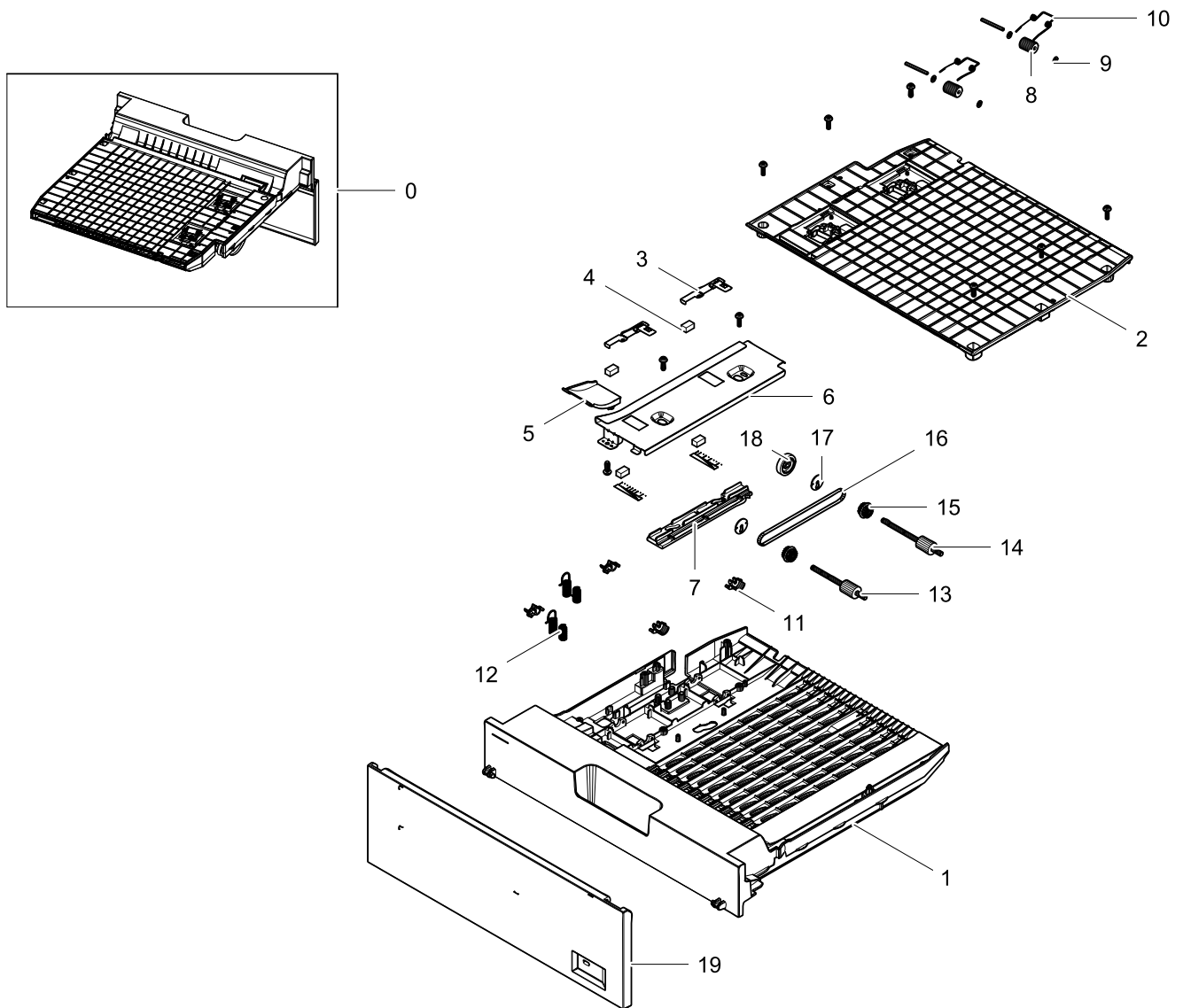

Parts List

No.	Lvl.	Loc.	Material Code	Description & Specification	SNA	Qty.
0	1		JC90-01018B	DUPLEX; ML-6510ND,SEE	SA	1
1	2		JC61-03842B	FRAME-DUPLEX_LOWER; ML-6510ND,ABS+PC,WAVE	SNA	1
2	2		JC61-03844A	FRAME-DUPLEX_UPPER; ML-6510ND,ABS+PC,BLAC	SNA	1
3	2		JC63-02656A	GROUND-DUPLEX_GASKET; ML-6510ND,SUS,0.2,N	SNA	1
4	2		JC63-02189A	GASKET; ML-5050ND,Polyurethane Foam,5mm,1	SNA	2
5	2		JC61-04153A	GUIDE-PAPER_DUPLEX; ML-6510ND,PC,BLACK,PA	SNA	1

Exploded Views and Parts List

No.	Lvl.	Loc.	Material Code	Description & Specification	SNA	Qty.
6	2		JC61-04154A	GUIDE-DUPLEX_ALIGN; ML-6510ND,SECC,0.6t,P	SNA	1
7	2		JC66-02837A	LEVER-ALIGN_DUPLEX; ML-6510ND,POM,GREEN	SA	1
8	2		JC66-02816A	ROLLER-IDLE_DUPLEX; ML-6510ND,POM,10,WHIT	SA	2
9	2	L8299	JK72-00058A	PCT-SILP WASHER; SRP-350,T0.5,P.A+GRAPHIT	SNA	4
10	2		6107-001667	SPRING-TS; SWP,SILVER COATING,PI0.75,ID3.	SA	2
11	2	H1231	JC61-00665A	BUSH-M-FEED, DUP; ML-2150,POM, SW01,4,0,7	SA	4
12	2	L7818	JC65-00017A	TERMINAL-P-GND DUP; SCX-5530FN,C5210W,PI0	SNA	1
13	2		JC90-01051A	DUPLEX FEEDER-LOWER; ML-6510ND,XEROX	SA	1
14	2		JC90-01052A	DUPLEX FEEDER-LOWER; ML-6510ND,XEROX	SA	1
15	2	F7328	JC66-00899A	PULLEY-18_DUP; ML-3560,POM,HB,WHITE, 4.1	SNA	2
16	2	G9085	6602-001084	BELT-TIMING GEAR; 30S2M224,RUB(CR),T1.36,	SA	1
17	2	F7340	JC66-00900A	PULLEY-M-18-DUMMY_DUP; ML-3560,POM,HB,WHI	SNA	2
18	2	C3331	JC66-00038A	GEAR-EXIT F/DOWN; ML-4500,POM,0.8,GREEN	SNA	1
19	2		JC63-01942C	COVER-CASSETTE; ML-6510ND,ABS,2.5,317.3,1	SA	1

5. Fuser

Exploded View

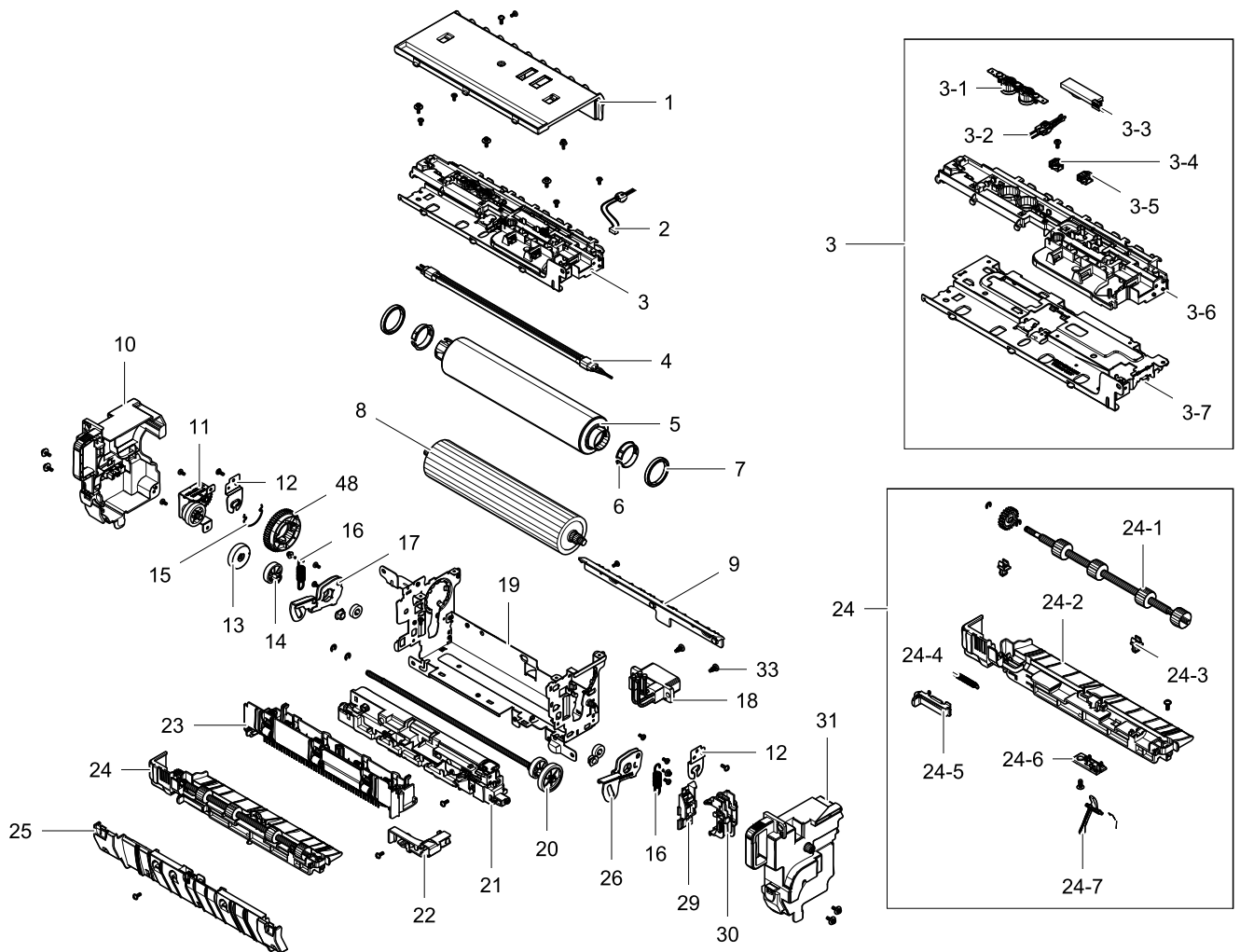

Parts List

No.	Lvl.	Loc.	Material Code	Description & Specification	SNA	Qty.
1	2		JC63-02651A	COVER-UPPER; ML-6510ND,PET+GF,112.31,245,	SNA	1
2	2		1404-001567	THERMISTOR-NTC ASSY; 7Kohm,3370K,0.3mW/C,	SA	1
3	2		JC91-01107A	FUSER-BRACKET UPPER; ML-6510ND,SEC, WORLD,	SNA	1
3-1	3		4712-001085	THERMOSTAT; AC125/250V,195+-5100	SNA	1
3-2	3		1404-001565	THERMISTOR-NTC ASSY; 7Kohm,3370K,0.3mW/C,	SA	1
3-3	3	L7827	1404-001453	THERMISTOR-NTC ASSY; 7Kohm,3370K	SA	1
3-4	3		3711-007520	CONNECTOR-HEADER; BOX,2P,1R,2.0mm,STRAIGH	SA	1

Exploded Views and Parts List

No.	Lvl.	Material Code	Description & Specification	SNA	Qty.	Remark
3-5	3	3711-007521	CONNECTOR-HEADER; BOX,3P,1R,2.0mm,STRAIGH	SNA	1	
3-6	3	JC61-03860A	HOLDER-THERMOSTAT; ML-6510ND,PET+GF30,46.	SNA	1	
3-7	3	JC61-03820A	BRACKET-FUSER_UPPER; ML-6510,EGI-SECC,1.2	SNA	1	
4	2	4713-001522	LAMP-HALOGEN; 230V,1300W,13x9.8x276	SA	1	For 220V model
		4713-001521	LAMP-HALOGEN; 115V,1300W,13x9.8x276	SA	1	For 110V model
5	2	JC66-02727A	ROLLER-HEAT; ML-6510ND,49.45,AL3304-H14 o	SA	1	
6	2	JC61-03883A	BUSH-HR; ML-6510ND,PPS,27,30	SA	2	
7	2	6601-001726	BEARING-BALL; SB6706ZZ,ID30,OD37,T4.0	SA	2	
8	2	JC66-02718A	ROLLER-PRESSURE; ML-6510ND,34,SUM22, STKM	SA	1	
9	2	JC61-03920A	GUIDE-INPUT; ML-6510ND,PET+GF,233,GF30%,P	SNA	1	
10	2	JC91-01108A	FUSER-COVER RIGHT; ML-6510ND,SEC,WORLD,11	SNA	1	
11	2	JC91-01099A	FUSER-BRACKET GEAR; ML-6510ND,SEC,WORLD,1	SNA	1	
12	2	JC61-03836A	BRACKET-LAMP_R; ML-6510ND,STAINLESS-ST30	SNA	2	
13	2	JC61-03859A	HOLDER-SHAFT_ENCORD; ML-6510ND,POM,PI30.8	SNA	1	
14	2	JC66-02619A	CAM-RELEASE-L; ML-6510ND,POM,H14.8,WHT	SNA	1	
15	2	6107-002620	SPRING-ETC; SUS304,1	SNA	1	
16	2	6107-002624	SPRING-ES; SWP B,PI1.5,L41.6,OD9.5,12,RIG	SA	2	
17	2	JC61-03826A	BRACKET-PR-R; ML-6510,EGI-SECC,1.6T,71.55	SNA	1	
18	2	JC39-01394A	HARNESS; ML-6510ND,HARNESS,UL10059,9,300,	SA	1	
19	2	JC91-01111A	FUSER-BRACKET LOWER; ML-6510ND,SEC,WORLD,	SNA	1	
20	2	JC91-01110A	FUSER-CAM SHAFT; ML-6510ND,SEC,WORLD,110V	SNA	1	
21	2	JC91-01098A	FUSER-ROLLER CLEAN; ML-6510ND,SEC,WORLD,1	SNA	1	
22	2	JC61-03856A	HOLDER-HARNESS_AC_SUB; ML-6510ND,PET+GF30	SNA	1	
23	2	JC91-01113A	FUSER-GUIDE EXIT UPPER; ML-6510ND,SEC,WOR	SA	1	

No.	Lvl.	Material Code	Description & Specification	SNA	Qty.	Remark
24	2	JC91-01106A	FUSER-GUIDE EXIT LOWER; ML-6510ND,SEC,WOR	SNA	1	
24-1	3	JC91-01022A	FUSER-ROLLER EXIT; ML-6510ND	SNA	1	
24-2	3	JC61-03921A	GUIDE-EXIT_LOWER; ML-6510ND,PET+GF,25.65,	SNA	1	
24-3	3	JC72-00382A	BUSH; ML-6060A,POM M9044,BLK	SNA	2	
24-4	3	6107-001237	SPRING-ES; SUS304-WPB,P0.5,D4.5,L42,ID4,O	SA	1	
24-5	3	JC61-01625A	HOLDER-M_REAR_LEVER; SCX-5530FN,PC,NH-102	SA	1	
24-6	3	JC61-03851A	HOLDER-ACTUATOR; ML-6510ND,PET+GF30,14.24	SNA	1	
24-7	3	JC66-02625A	ACTIONATOR; ML-6510ND,NYLON+GF25,W14.75,Bla	SA	1	
25	2	JC91-01109A	FUSER-COVER DUPLEX; ML-6510ND,SEC,WORLD,1	SNA	1	
26	2	JC61-03829A	BRACKET-PR_L; ML-6510,EGI-SECC,1.6T,71.55	SNA	1	
29	2	JC61-03857A	HOLDER-HARNES DC; ML-6510ND,PET+GF30,27.	SNA	1	
30	2	JC61-03855A	HOLDER-HARNES AC; ML-6510ND,PET+GF30,22.	SNA	1	
31	2	JC91-01112A	FUSER-COVER LEFT; ML-6510ND,SEC,WORLD,110	SNA	1	
33	2	6009-001711	SCREW-SPECIAL; PH,+,M3,L3.8,Ni PLT,SWRCH1	SNA	2	
48	2	JC66-02615A	GEAR-FUSER; ML-6510ND,PPS,1,51,53	SA	1	

6. Frame

Exploded View

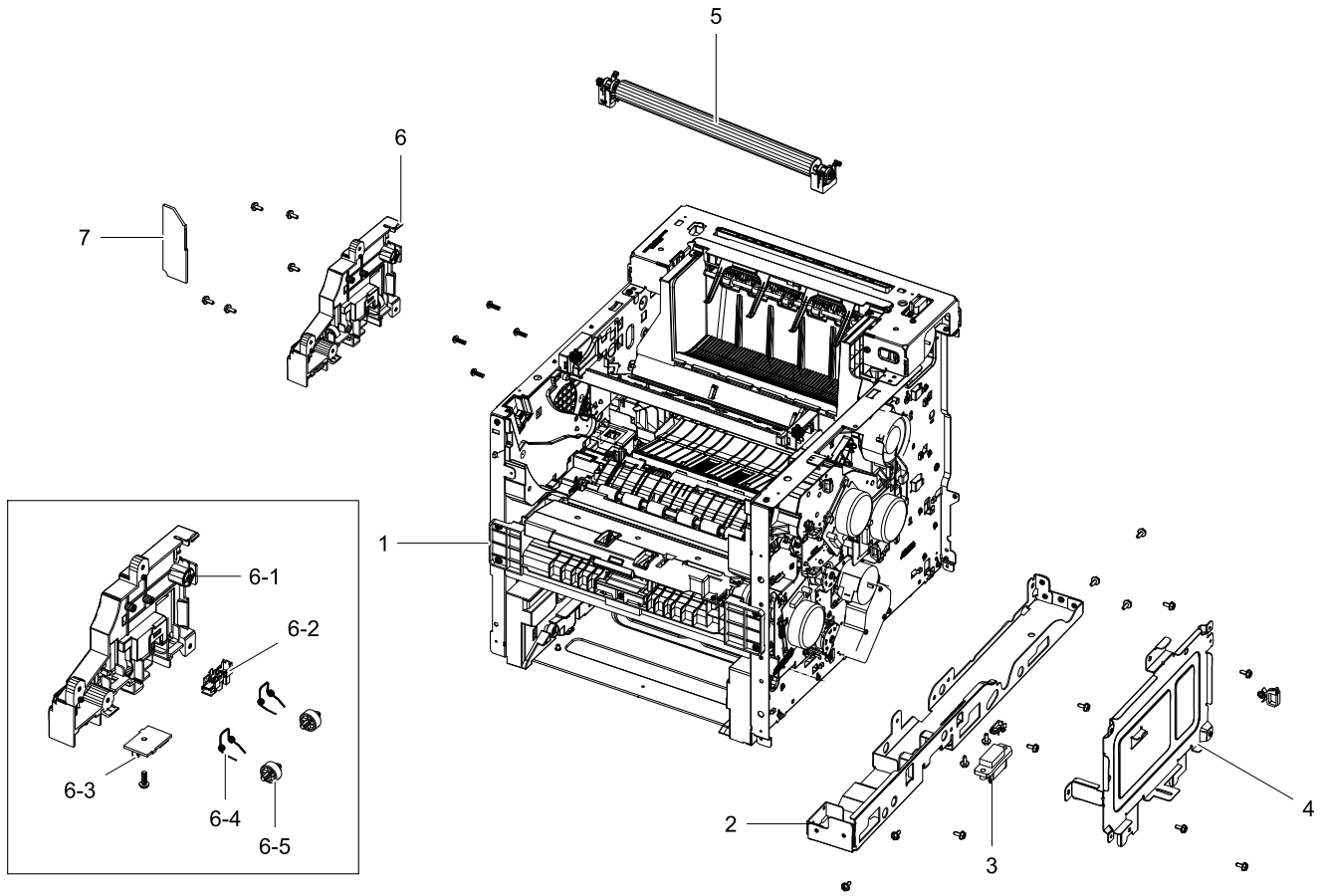

Parts List

No.	Lvl.	Loc.	Material Code	Description & Specification	SNA	Qty.
1	2		JC93-00273B	FRAME MAIN; ML-6510ND,XAA	SNA	1
2	3		JC61-03817A	BRACKET-RIGHT_LOWER; ML-6510ND,SECC,T1.0,	SNA	1
3	3		JC39-01375A	HARNESS-SCF; ML-6510ND,HARNESS,UL10272,18	SA	1
4	2		JC61-03818A	BRACKET-ENGINE_CONTROLLER; ML-6510ND,SECC	SNA	1
5	2		JC93-00271B	FRAME-ROLLER_TRANSFER; ML-6510ND,XAA	SA	1
6	2		JC93-00247A	FRAME-TERMINAL; ML-6510ND,XXR	SNA	1
6-1	3		JC61-03907A	HOUSING-TERMINAL; ML-6510ND,ABS+PC,W152,L	SNA	1
6-2	3		0604-001325	PHOTO-INTERRUPTER; TR,BK	SA	1
6-3	3		JC92-02340B	PBA-WASTE_SENSOR_RX; ML-5510ND,SEC,5V/3.3	SNA	1
6-4	3		6107-002693	SPRING-TS; SWP B,0.6,3.5,2.9,4.1,3.2,10.7	SNA	1

No.	Lvl.	Loc.	Material Code	Description & Specification	SNA	Qty.
6-5	3	L4550	JC66-01143A	ROLLER-SLIDE B; CLP-300,POM	SNA	2
7	2		JC72-01587A	SPONGE-SMPS; ML-6510ND,PORON,BLACK	SNA	1

6.1. Frame Main

Exploded View

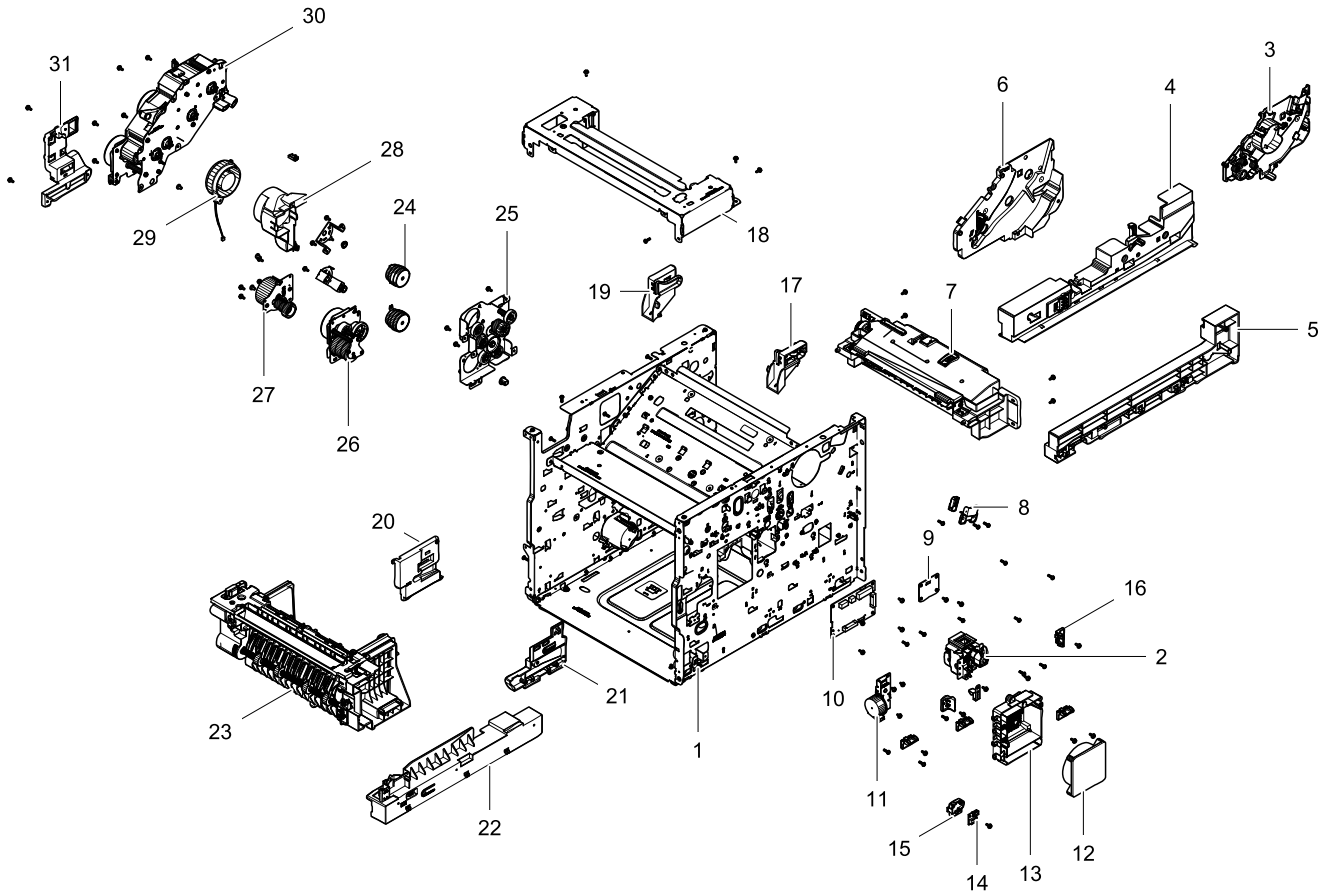

Parts List

No.	Lvl.	Loc.	Material Code	Description & Specification	SNA	Qty.
1	3		JC93-00272A	FRAME BASE; ML-6510ND,XRX	SNA	1
2	3		JC93-00269A	FRAME-DUCT WASTE TONER; ML-6510ND,SEC,WOR	SA	1
3	3		JC93-00246A	FRAME-GUIDE OPC LEFT; ML-6510ND,XRX	SNA	1
4	3		JC93-00250A	FRAME-GUIDE CASSETTE RIGHT; ML-6510ND,XRX	SNA	1
5	3		JC93-00243A	FRAME-GUIDE CASSETTE LEFT; ML-6510ND,XRX	SNA	1
6	3		JC93-00252A	FRAME-GUIDE OPC RIGHT; ML-6510ND,XRX	SNA	1
7	3		JC90-01020A	MP; ML-6510ND,XEROX	SA	1
8	3		JC61-03905A	HOLDER-CONNECTOR_TONER; ML-6510ND,ABS,W31	SA	1
9	3		JC92-02376A	PBA-ZENER; ML-5510ND,XEROX	SA	1
10	3		JC92-02282A	PBA-JOINT; ML-5510ND,SEC,A3983SLP,24V/3.3	SA	1

No.	Lvl.	Loc.	Material Code	Description & Specification	SNA	Qty.
11	3		JC93-00232A	DRIVE FUSER-RELEASE; ML-6510ND,Xerox,USA,	SA	1
12	3		JC31-00141A	FAN; D08K-24PU 21B(AX),65g	SA	1
13	3		JC61-03835A	HOLDER-FAN_SMPS; ML-6510ND,ABS+PC,W105.5,	SA	1
14	3	L5841	JC32-00005A	SENSOR-HUMIDITY; CHS-CSC-20,CLP-660,0~50C	SA	1
15	3		JC61-03217A	HOLDER-SENSOR HUMIDITY; CLX-9350,PC+ABS,1	SNA	1
16	3		JC61-03941A	GUIDE-WTB; ML-6510ND,POM,W21,L24,black,GU	SNA	5
17	3		JC61-03877A	GUIDE-COVER_OPEN_L; ML-6510ND,ABS+PC,W55,	SNA	1
18	3		JC61-03815A	BRACKET-SUPPORT_REAR; ML-6510ND,SECC,T1.2	SNA	1
19	3		JC61-03876A	GUIDE-COVER_OPEN_R; ML-6510ND,PC ABS,W64.	SNA	1
20	3		JC61-03873A	GUIDE-FUSER_SIDE_R; ML-6510ND,ABS,W104.9,	SNA	1
21	3		JC61-03869A	GUIDE-FUSER_SIDE_L; ML-6510ND,ABS,W136.1,	SNA	1
22	3		JC93-00244A	FRAME-GUIDE DUPLEX LEFT; ML-6510ND,XRX	SNA	1
23	3		JC90-01013B	EXIT; ML-6510ND,XAA	SA	1
24	3		JC66-00994C	CLUTCH-SPUR; CLX-9350,5.0Kgf,Z32,M1.0,OD3	SA	2
25	3		JC93-00229A	DRIVE-FEED; ML-6510ND,Xerox,USA,110V/220V	SA	1
26	3		JC93-00226A	DRIVE FUSER; ML-6510ND,Xerox,USA,110V/220	SA	1
27	3		JC93-00228A	DRIVE-DUPLEX; ML-6510ND,Xerox,USA,110V/22	SA	1
28	3		JC61-03840A	HOLDER-FAN_LSU; ML-6510ND,ABS,W97.5,L57.4	SA	1
29	3	I4723	JC31-00086A	FAN-DC; CLX-8380ND/XAA,PBT+GF,UL10272 AWG	SA	1
30	3		JC93-00230A	DRIVE MAIN; ML-6510ND,Xerox,USA,110V/220V	SA	1
31	3		JC61-03879A	GUIDE-HARNESS_FRAME; ML-6510ND,PC,W147.6,	SNA	1

6.1.1. Exit

Exploded View

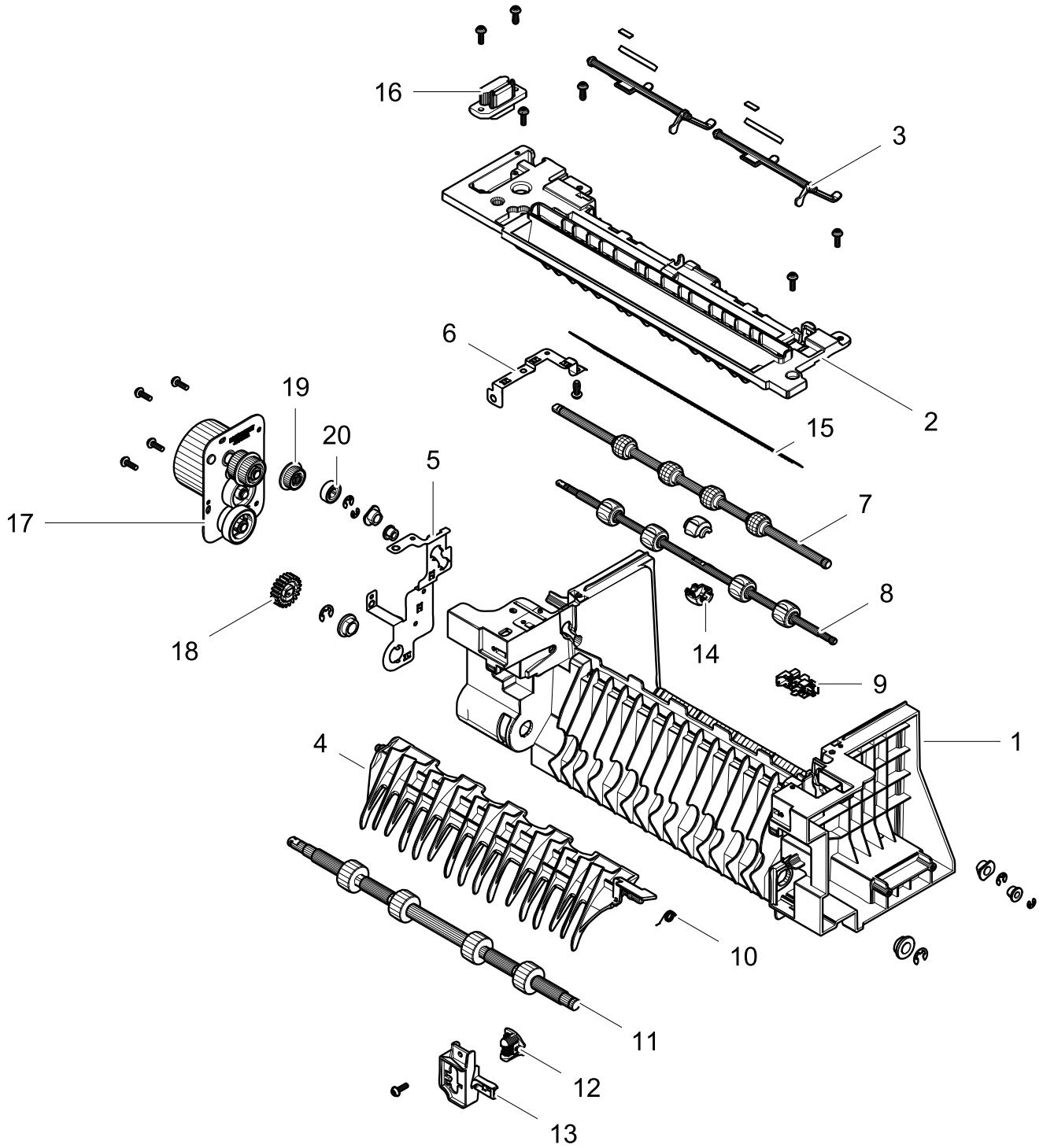

Parts List

No.	Lvl.	Loc.	Material Code	Description & Specification	SNA	Qty.
1	4		JC61-03862B	FRAME-EXIT; ML-6510ND,ABS,HB,Wave Gray	SNA	1
2	4		JC61-03878A	FRAME-CAP_EXIT; ML-6510ND,ABS+PC,BLACK	SNA	1
3	4		JC66-02621A	LEVER-STACKING; ML-6510ND,PC,BLACK,LINK/U	SA	2
4	4		JC61-03891A	GUIDE-DEFLECTOR; ML-6510ND,PPE+PS,BLACK,P	SNA	1
5	4		JC63-02657A	GROUND-EXIT_ROLLER; ML-6510ND,SUS,0.2,NTR	SNA	1
6	4		JC63-02658A	GROUND-EXIT; ML-6510ND,SUS,0.2,NTR,GROUND	SNA	1
7	4		JC66-02663A	ROLLER-EXIT_UPPER; ML-6510ND,EPDM	SNA	1
8	4		JC66-02664A	ROLLER-EXIT_LOWER; ML-6510ND,EPDM	SNA	1
9	4		0604-001325	PHOTO-INTERRUPTER; TR,BK	SA	1
10	4		6107-001500	SPRING-TS; SWP,PI0.55,ID6.1,OD7.2	SA	1
11	4		JC66-02665A	ROLLER-EXIT_DUPLEX; ML-6510ND,EPDM	SNA	1
12	4		JC39-00992A	HARNESS-REAR_JOINT_FR; ML-5050ND,UL/CSA,6	SA	1
13	4		JC61-02634A	BRACKET-MALE_REAR; ML-5050ND,PC,T2.0,W40.	SNA	1
14	4		JC67-00477A	CAP-ROLLER_EXIT; ML-6510ND,PC,Black	SNA	2
15	4	E0304	JC75-00095A	MEC-BRUSH ANTISTATIC; ML-6060A,SEC,NTR	SA	1
16	4	C4761	JC39-00710A	HARNESS-SENS T1 ENGA; CLX-8380ND,UL10272,	SNA	1
17	4		JC93-00227A	DRIVE_EXIT; ML-6510ND,Xerox,USA,110V/220V	SA	1
18	4	I5712	JC66-00854A	GEAR-M-EXIT DUP Z21; ML-3560,POM,1,21,WHT	SA	1
19	4	I5638	JC66-01018A	GEAR-M_EXIT LOWER; SCX-6345N/XRX,POM,0.8,	SA	1
20	4	I5639	JC66-01017A	GEAR-M_EXIT UPPER; SCX-6345N/XRX,POM,0.8,	SA	1

6.1.2. MP

Exploded View

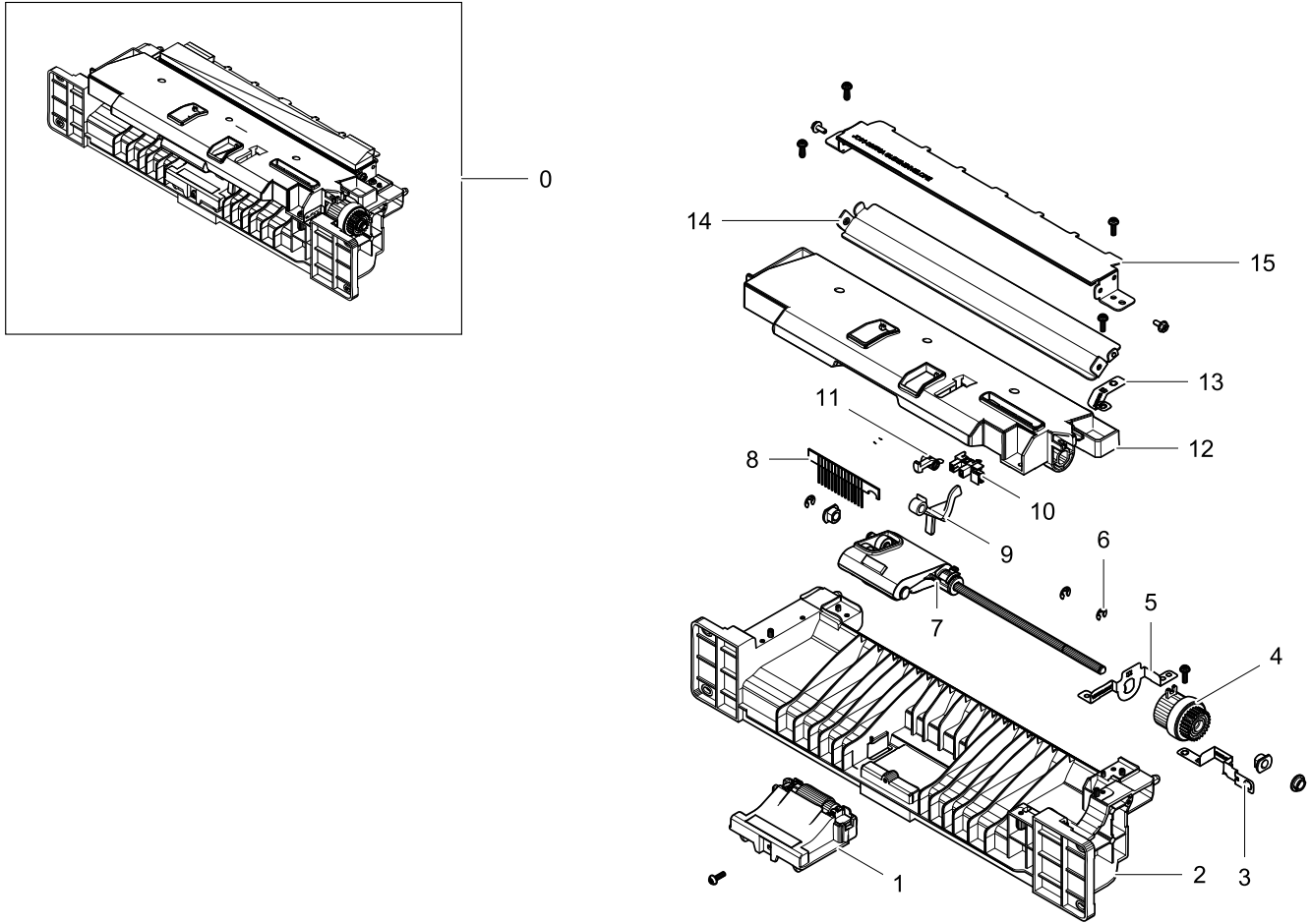

Parts List

No.	Lvl.	Loc.	Material Code	Description & Specification	SNA	Qty.
0	3		JC90-01020A	MP; ML-6510ND,XEROX	SA	1
1	4		JC90-01014A	MP-LOWER RETARD; ML-6510ND,XEROX	SA	1
2	4		JC61-03893A	FRAME-MP_BOTTOM; ML-6510ND,PC,NH-1035,BLA	SNA	1
3	4		JC63-02663A	GROUND-MP; ML-6510ND,SUS,0.2,14,48,GROUND	SNA	1
4	4	B0440	JC47-00023A	CLUTCH-FEED; ML-5050,DC24V,167mA	SA	1
5	4		JC63-02665A	GROUND-MP_TOP; ML-6510ND,SUS,0.2,15.5,44,	SNA	1
6	4	F8266	6044-000125	RING-E; ID4,OD9,T0.6,STSC	SA	3
7	4		JC90-01012A	MP-PICK UP; ML-6510ND,XEROX	SA	1
8	4		JC67-00507B	BRUSH-PICK MP; ML-6510ND,SUS FIBER,23,68.	SNA	1
9	4		JC61-03892A	STOPPER-PAPER_MP; ML-6510ND,POM,2.5,12.5,	SA	1

No.	Lvl.	Loc.	Material Code	Description & Specification	SNA	Qty.
10	4		0604-001325	PHOTO-INTERRUPTER; TR,BK	SA	1
11	4	J3397	JC66-00958B	LATCH-M_ARM REAR; SCX-6345N/XRX,POM,T1.5,	SNA	1
12	4		JC61-03894A	FRAME-MP_TOP; ML-6510ND,PC,V0,BLACK,3.0,8	SNA	1
13	4		JC63-02664A	GROUND-MP_RELEASE; ML-6510ND,SUS,0.2,25.5	SNA	1
14	4		JC61-03871A	GUIDE-MP_RELEASE; ML-6510ND,SECC,1.2,247,	SNA	1
15	4		JC61-03864A	GUIDE-ENVELOPE; ML-6510ND,SECC,1.2,18,274	SNA	1

6.1.3. Drive Fuser

Exploded View

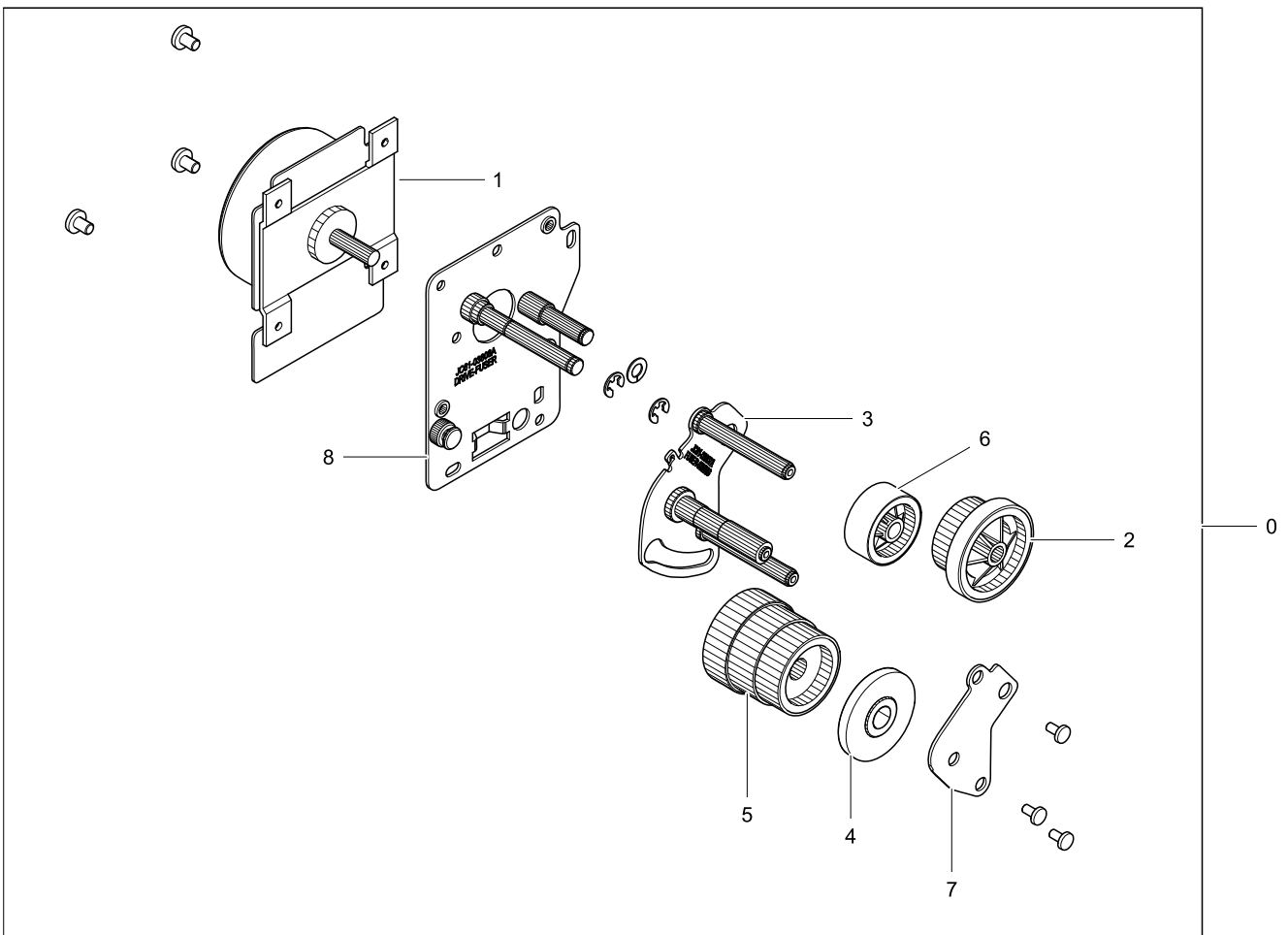

Parts List

No.	Lvl.	Loc.	Material Code	Description & Specification	SNA	Qty.
0	3		JC93-00226A	DRIVE FUSER; ML-6510ND,Xerox,USA,110V/220	SA	1
1	4	K1287	JC31-00090A	MOTOR BLDC; 2220 RPM,1400gf.cm,DC24V,2.1A	SA	2
2	4		JC66-02652A	GEAR-RDCN_3X5; ML-6510ND,POM,A0.5/B1.0,A4	SA	1
3	4		JC61-03807A	BRACKET-FUSER_SWING; ML-6510ND,EGI-SECC,1	SNA	1
4	4		JC61-03914A	SUPPORT-GAP_RING; ML-6510ND,PPS+GF,33.12,	SNA	1
5	4		JC66-02634A	GEAR-RDCN_FUSER; ML-6510ND,PA,A0.5/B1.0,A	SA	1
6	4		JC66-02633A	GEAR-DRV_OPC; ML-6510ND,POM,0.5,47,25.008	SA	1
7	4		JC61-03961A	BRACKET-SWING_INNER; ML-6510ND,EGI-SECC,1	SNA	1
8	4		JC61-03808A	BRACKET-DRIVE FUSER; ML-6510ND,EGI-SECC,1	SNA	1

6.1.4. Drive Feed

Exploded View

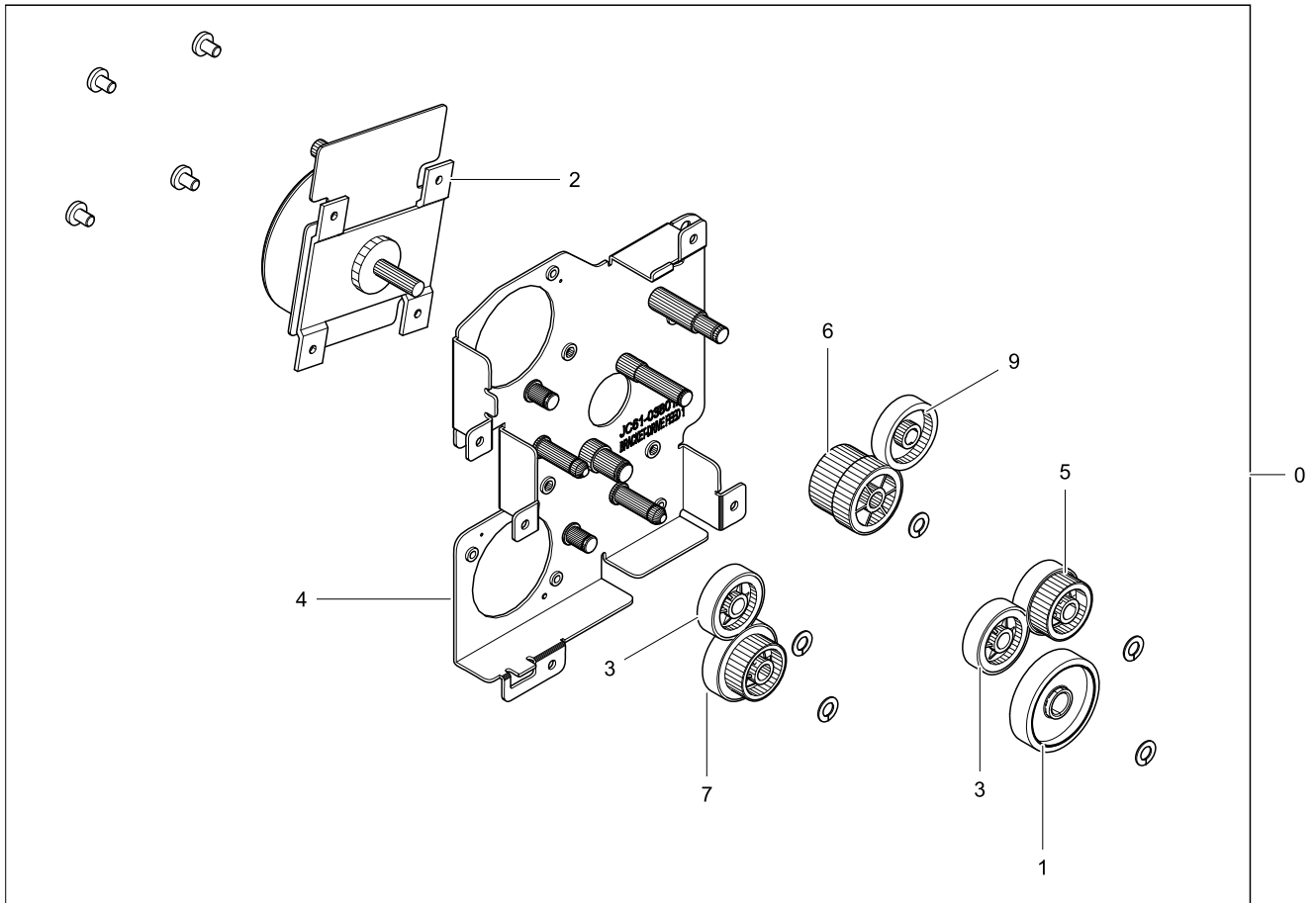

Parts List

No.	Lvl.	Loc.	Material Code	Description & Specification	SNA	Qty.
0	3		JC93-00229A	DRIVE-FEED; ML-6510ND,Xerox,USA,110V/220V	SA	1
1	4	I5533	JC66-01376A	GEAR-IDLE OPC; CLP-660,POM(M90-44),M0.5,Z	SA	1
2	4	K1287	JC31-00090A	MOTOR BLDC; 2220 RPM,1400gf.cm,DC24V,2.1A	SA	2
3	4		JC66-02643A	GEAR-FEED_IDLE; ML-6510ND,POM,1,23,23,WHI	SNA	2
4	4		JC61-03801A	BRACKET-DRIVE FEED 1; ML-6510ND,SECC,1,2,	SNA	1
5	4		JC66-02645A	GEAR-RDCN_FORWARD; ML-6510ND,POM,A0.5/B1.	SA	1
6	4		JC66-02649A	GEAR-RDCN_FEED; ML-6510ND,POM,A0.5/B0.8,A	SA	1

No.	Lvl.	Loc.	Material Code	Description & Specification	SNA	Qty.
7	4		JC66-02644A	GEAR-RDCN_REGI; ML-6510ND,POM,A0.5/B1.0,A	SA	1
9	4	I5729	JC66-00861A	GEAR-M-MP DRV; ML-3560,POM,0.8,31,WHT,26.	SA	1

6.1.5. Drive Main

Exploded View

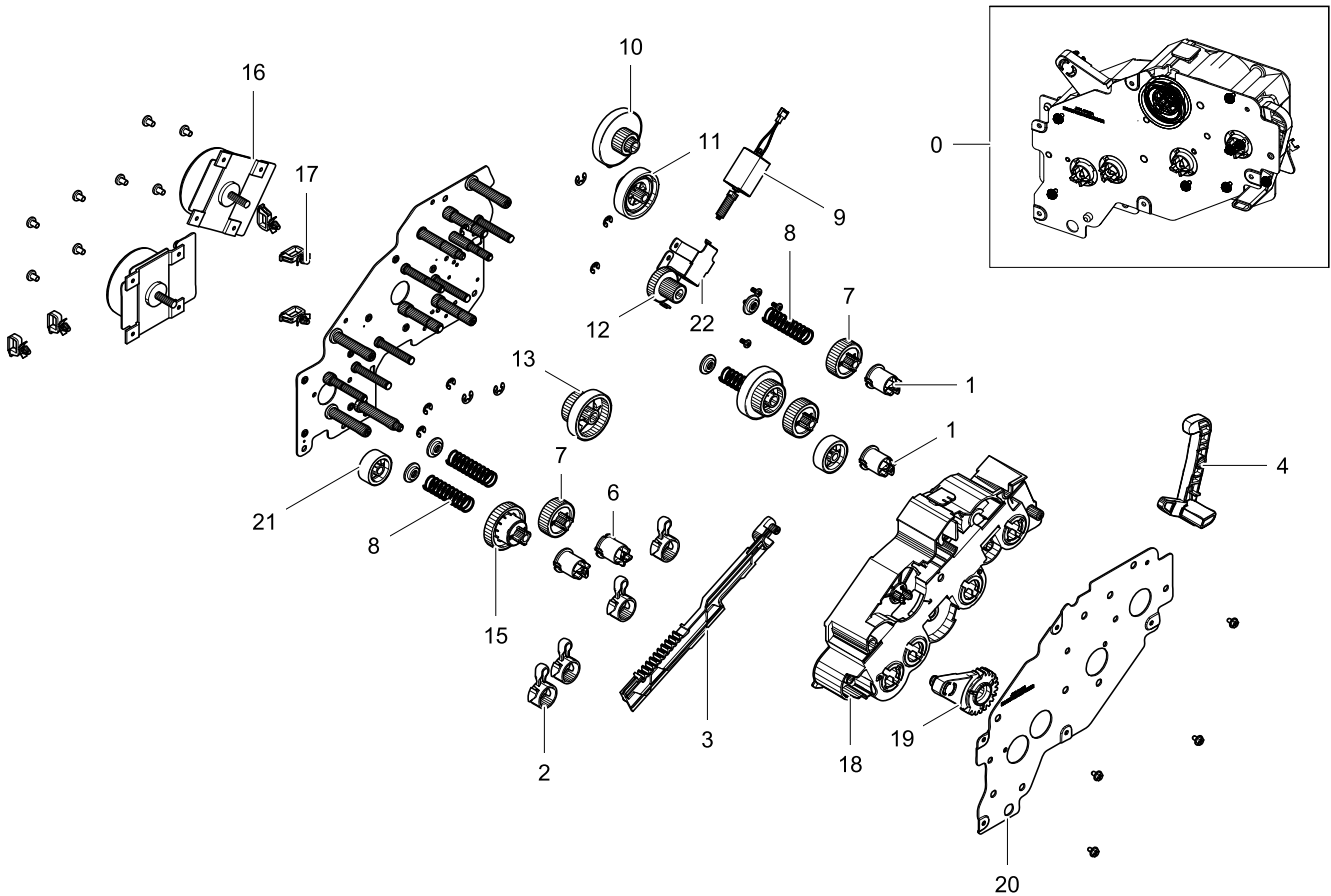

Parts List

No.	Lvl.	Loc.	Material Code	Description & Specification	SNA	Qty.
0	3		JC93-00230A	DRIVE MAIN; ML-6510ND,Xerox,USA,110V/220V	SA	1
1	4		JC67-00461A	COUPLER-CARTRIDGE_OPC; ML-6510ND,POM,Dia.	SNA	3
2	4		JC61-03865A	HOLDER-CAM_COUPLING; ML-6510ND,POM,1.5,20	SNA	4
3	4		JC66-02629A	LINK-COUPLING_RACK; ML-6510ND,POM,188.8,1	SNA	1
4	4		JC66-02631A	LINK-TONER_SHUTTER; ML-6510ND,POM,85.303,	SA	1

No.	Lvl.	Loc.	Material Code	Description & Specification	SNA	Qty.
6	4		JC67-00460A	COUPLER-CARTRIDGE_MAG; ML-6510ND,POM,Dia.	SNA	1
7	4		JC66-02641A	GEAR-COUPLING; ML-6510ND,POM,0.8,33,28.09	SA	3
8	4		6107-002662	SPRING-CS; SUS304,1.0,11.8,42.28,10.8,12.	SNA	4
9	4	K1299	JC31-00078A	MOTOR DC; NF213G-1020515,DC24V,CLX-8380ND	SA	1
10	4		JC66-02638A	GEAR-DRV_TONER_1; ML-6510ND,POM,A0.8/B0.8	SA	1
11	4	I5869	JC66-01051A	GEAR-RDCN DEVE; CLP-300,POM,A:0.5,B:0.8,Z	SNA	1
12	4		JC66-02650A	GEAR-DRV_SUPPLY; ML-6510ND,POM,A0.6/B0.8,	SA	1
13	4		JC66-02646A	GEAR-RDCN_MAG; ML-6510ND,POM,A0.8/B0.5,A4	SA	1
15	4		JC66-02642A	GEAR-COUPLING-OPC; ML-6510ND,POM,0.5,69,3	SA	1
16	4	K1287	JC31-00090A	MOTOR BLDC; 2220 RPM,1400gf.cm,DC24V,2.1A	SA	2
17	4	L9648	6502-001132	SADDLE; 11.6X8.8,Nylon66,BLACK	SA	5
18	4		JC63-02653A	COVER-COUPLING; ML-6510ND,ABS,1.5,107.5,1	SNA	1
19	4		JC66-02630A	LINK-COUPLING_PINION; ML-6510ND,POM,41,1.	SNA	1
20	4		JC61-03802A	BRACKET-DRIVE CARTRIDGE INNER; ML-6510ND,	SNA	1
21	4		JC66-02633A	GEAR-DRV_OPC; ML-6510ND,POM,0.5,47,25.008	SA	1
22	4	H1121	JC61-01370A	BRACKET-P-TONER MOTOR; SCX-6345N/XRX,SECC	SNA	1

6.1.6. Frame Base

Exploded View

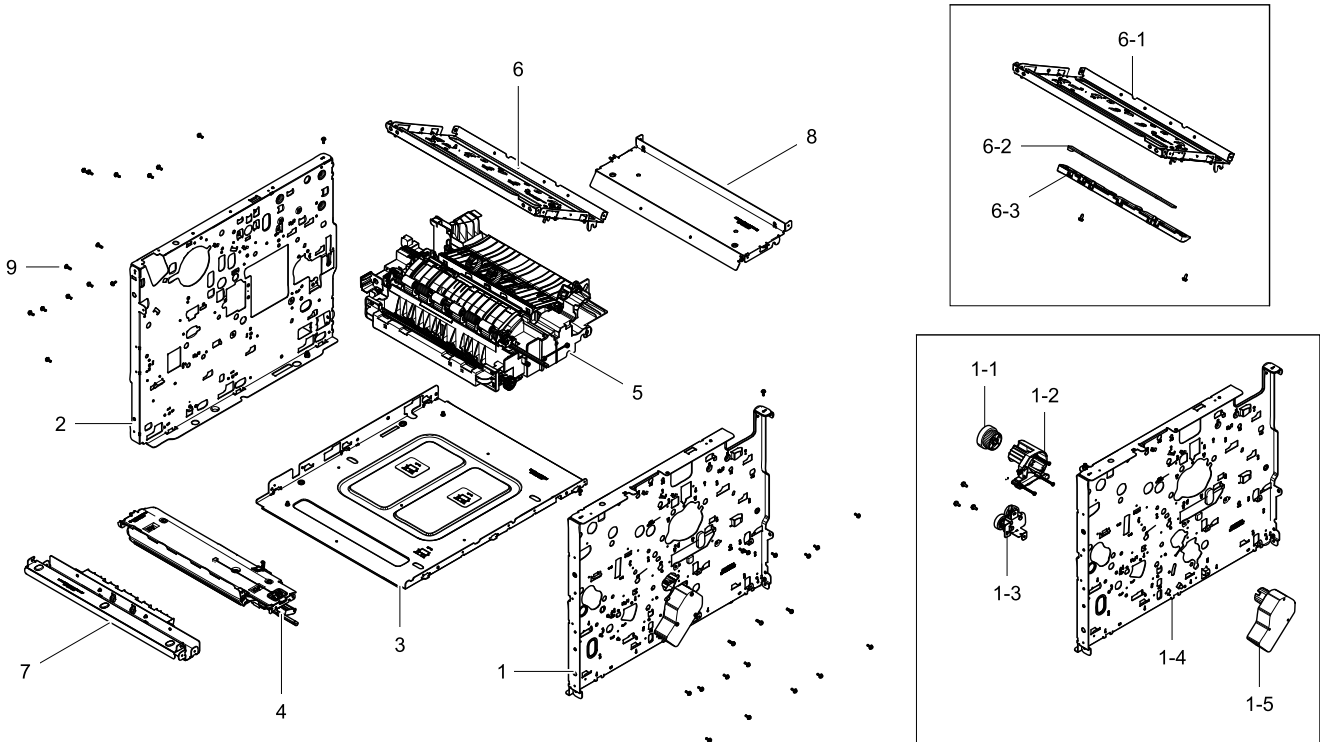

Parts List

No.	Lvl.	Loc.	Material Code	Description & Specification	SNA	Qty.
1	4		JC93-00248A	FRAME-RIGHT; ML-6510ND,XRX	SNA	1
1-1	5		JC66-02710A	GEAR-IDLE_LIFT; ML-6510ND,POM,1.5,23,34.5	SA	1
1-2	5		JC61-03962A	HOLDER-CASSETTE_LIFT; ML-6510ND,ABS,2.5,6	SA	1
1-3	5		JC93-00225A	DRIVE-PICK UP; ML-6510ND,Xerox,USA,110V/2	SA	1
1-4	5		JC61-03810A	FRAME-RIGHT; ML-6510ND,EGI-SECC,NTR,1.2,W	SNA	1
1-5	5	K1332	JC31-00045A	MOTOR GEARED-P LIFT; 2.1rpm,1.5N.m,1/1513	SA	1
2	4		JC93-00242A	FRAME-LEFT; ML-6510ND,XRX	SNA	1
3	4		JC93-00253A	FRAME-BOTTOM; ML-6510ND,XRX	SNA	1
4	4		JC93-00240A	FRAME-PICKUP; ML-6510ND,XEROX	SA	1
5	4		JC93-00256A	FRAME-MIDDLE; ML-6510ND,XRX	SNA	1
6	4		JC93-00255A	FRAME-UPPER; ML-6510ND,XRX	SNA	1
6-1	5		JC61-03824A	FRAME-LSU_LOWER; ML-6510ND,EGI-SECC,NTR,1	SNA	1
6-2	5		JC92-02287A	PBA-ERASER; ML-5510ND,XEROX,24V	SNA	1
6-3	5		JC61-03843A	HOLDER-PBA_LED; ML-6510ND,PC,W21.4,L285,C	SNA	1
7	4		JC93-00261A	FRAME-FRONT; ML-6510ND,XRX	SNA	1

No.	Lvl.	Loc.	Material Code	Description & Specification	SNA	Qty.
8	4		JC61-03825A	FRAME-FUSER_UPPER; ML-6510ND,EGI-SECC,NTR	SNA	1
9	2	F9909	6003-000196	SCREW-TAPTTYPE; PWH,+,B,M3,L10,NI PLT,SWRC	SNA	4

6.1.6.1. Frame Pick-Up

Exploded View

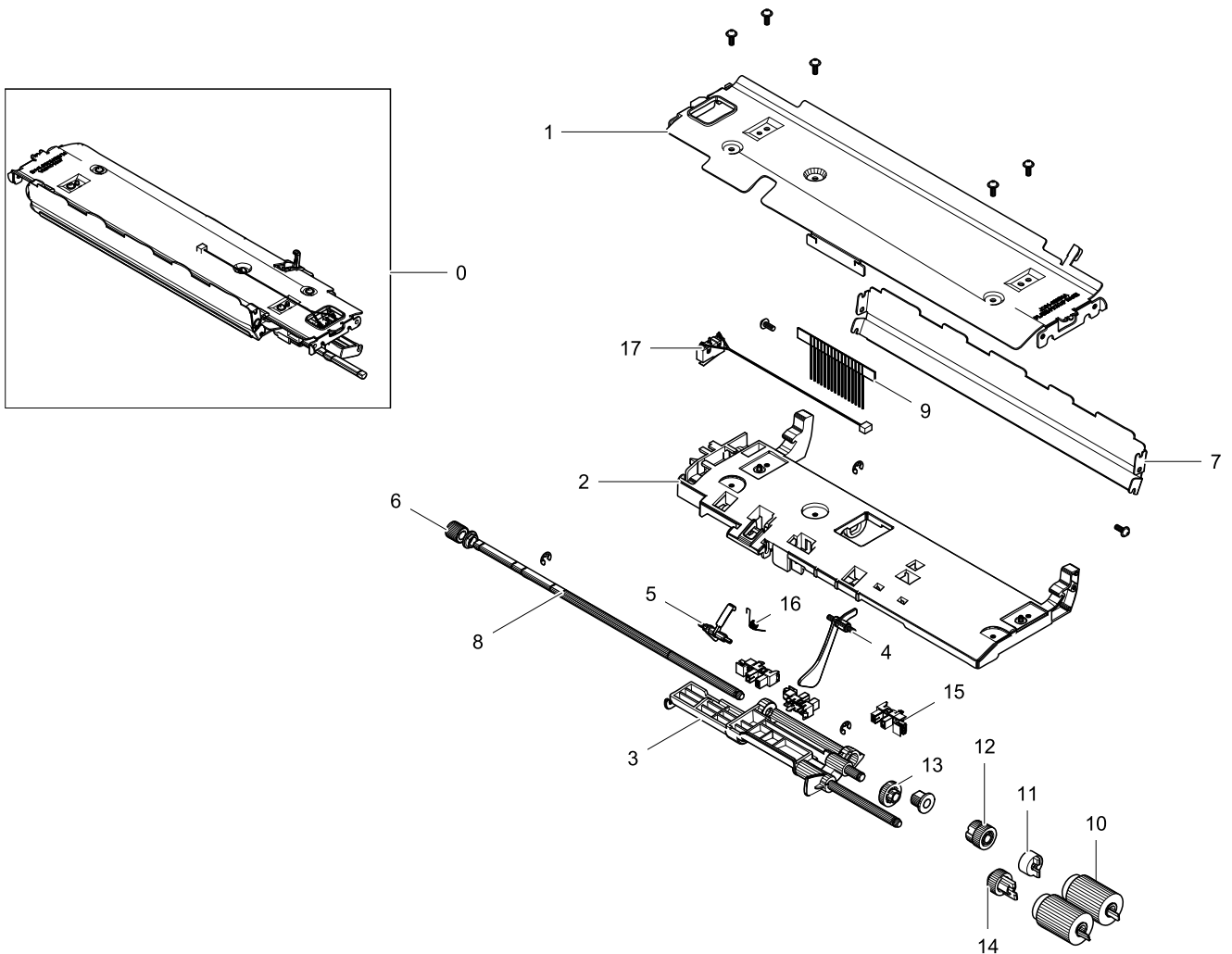

Parts List

No.	Lvl.	Loc.	Material Code	Description & Specification	SNA	Qty.
0	4		JC93-00240A	FRAME-PICKUP; ML-6510ND,XEROX	SA	1
1	5		JC61-03850A	PLATE-PICKUP_BASE; ML-6510ND,EGI-SECC,1.2	SNA	1
2	5		JC61-03823A	HOLDER-PICK_UP; ML-6510ND,ABS,2.5,44.4,28	SNA	1

Exploded Views and Parts List

No.	Lvl.	Loc.	Material Code	Description & Specification	SNA	Qty.
3	5		JC61-03846A	HOUSING-PICK_UP; ML-6510ND,PC+GF,2.5,202.	SNA	1
4	5		JC66-02613A	ACTUATOR-PAPER_EMPTY; ML-6510ND,PC,2,24.1	SA	1
5	5		JC66-02614A	ACTUATOR; ML-6510ND,PC+GF,2.5,29,12.5,BLA	SA	1
6	5		JC66-02632A	GEAR-DRV_PICKUP; ML-6510ND,POM,0.6,17,10.	SNA	1
7	5		JC61-03849A	PLATE-GUIDE_PAPER; ML-6510ND,EGI-SECC,0.8	SNA	1
8	5		JC66-02653A	SHAFT-PICK_UP; ML-6510ND,SUM 22,248,6.0,S	SNA	1
9	5		JC67-00468B	BRUSH-PICK; ML-6510ND,35,71.7,NTR	SNA	1
10	5	J9057	JC97-02259A	MEA UNIT-ROLLER PU; SCX-6345N/XRX,XEROX,-	SA	2
11	5	J8666	JC97-02292A	MEA UNIT-IDLE FORWARD; SCX-6345N/XRX,XERO	SNA	1
12	5	J8520	JC97-02291A	MEA UNIT-GEAR ONE WAY; SCX-6345N/XRX,XERO	SNA	1
13	5	I5652	JC66-00940A	GEAR-M_IDLE PU; SCX-6345N/XRX,POM,0.7,22,	SA	1
14	5	I5681	JC66-00943A	GEAR-M_PU JOINT; SCX-6345N/XRX,POM,0.7,21	SA	1
15	5		0604-001325	PHOTO-INTERRUPTER; TR,BK	SA	3
16	5	L7541	6107-001261	SPRING-TS; SUS304-WPB,PI0.35,D5.15,L12/12	SA	1
17	5		JC39-01382A	HARNESS-PICKUP; ML-6510ND,HARNESS,UL10272	SNA	1

6.1.6.2. Frame-Middle

Exploded View

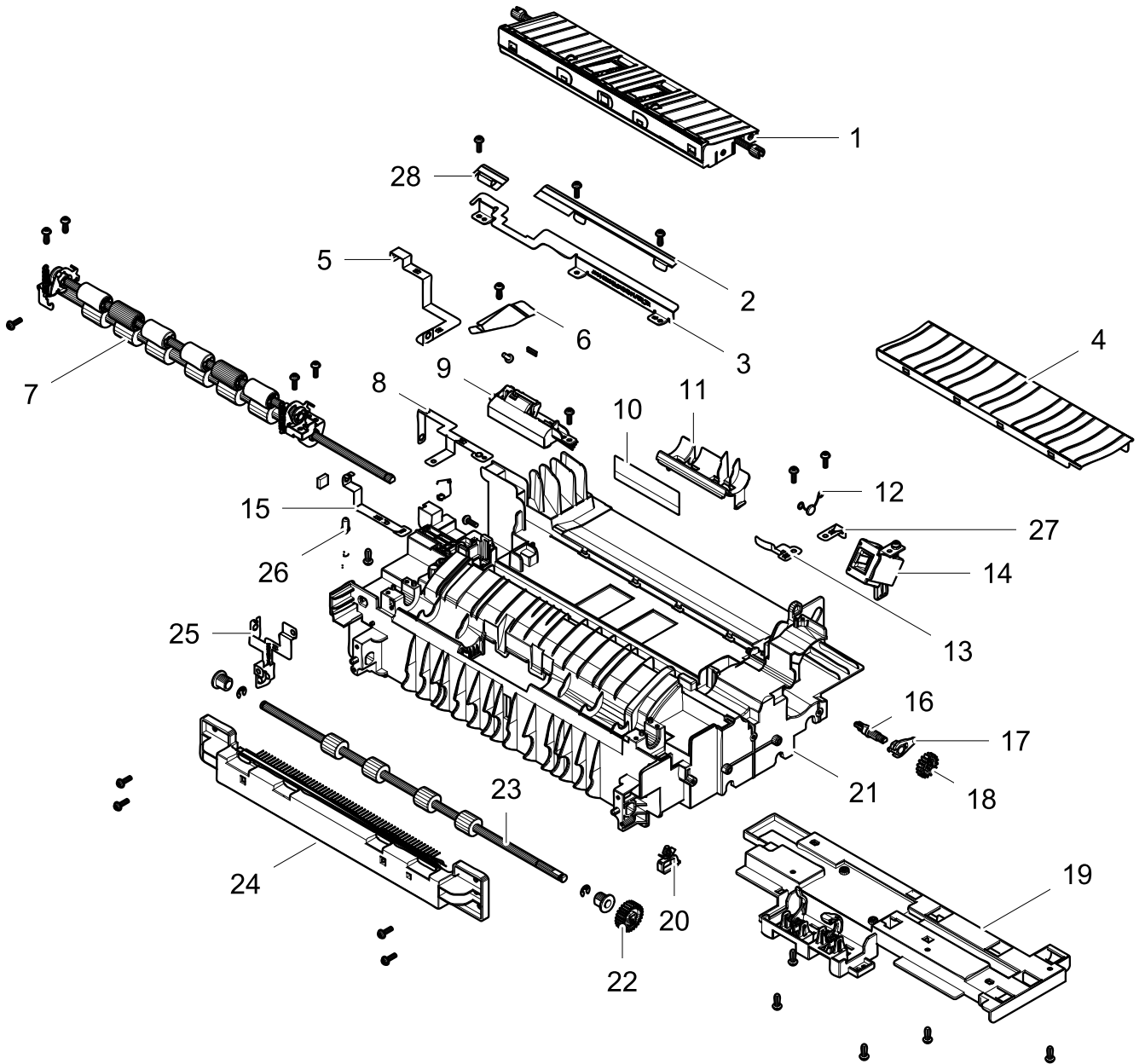

Parts List

No.	Lvl.	Loc.	Material Code	Description & Specification	SNA	Qty.
1	5		JC93-00258A	FRAME-SHAFT; ML-6510ND,XRX	SA	1
2	5		JC63-02963A	SHEET-GUIDE_PLATE_TR; ML-6510ND,PET,0.188	SNA	1
3	5		JC61-03904A	GUIDE-PLATE_TR; ML-6510ND,SECC,T1.0,W211.	SNA	1
4	5		JC61-04321A	GUIDE-TRANSFER_REAR; ML-6510ND,SECC,T0.6,	SNA	1

Exploded Views and Parts List

No.	Lvl.	Loc.	Material Code	Description & Specification	SNA	Qty.
5	5		JC63-02671A	EARTH; ML_6510ND,SUS,0.2,W34.5,L42.9,NTR,	SNA	1
6	5		JC63-02872A	SHEET-FAN-SMPS; ML-6510ND,PC,0.254,W35.6,	SNA	1
7	5		JC93-00239A	FRAME-REGI; ML-6510ND,XEROX	SA	1
8	5		JC63-03083A	GROUND-EARTH_TR; ML-6510ND,SUS,0.2,W82.3,	SNA	1
9	5		JC93-00279A	FRAME-SENSOR CTD; ML-6510ND,XRX	SA	1
10	5		JC63-02825A	SHEET-FEED CTD; ML-6510ND,PET,0.188,W21,L	SNA	1
11	5		JC67-00456A	CAP-ACTUATOR; ML-6510ND,ABS,W28,L71.82,bl	SNA	1
12	5	I0812	JC96-01772A	ELA HOU-VARISTOR; ML-6060,NEC/SEC,110/220	SA	1
13	5		JC63-03086A	GROUND-VARISTOR; ML-6510ND,SUS,0.2,W37.31	SNA	1
14	5		JC93-00260A	FRAME-HOLDER CONNECTOR; ML-6510ND,XRX	SNA	1
15	5		JC63-02685A	GROUND-TR; ML-6510ND,SUS,0.2,W24,L63.4,NT	SNA	1
16	5	L5931	JC66-00888A	SHAFT-M BELT_GEAR; ML-3560,PC,32.2,8,BLAC	SA	1
17	5	K8195	JC72-41191B	SHAFT; ML-2150,POM,BLK,DE8903	SNA	1
18	5	I5713	JC66-00674A	GEAR-M-EXIT Z17; ML-2550,M90-44,1,17,5,	SA	1
19	5		JC93-00257A	FRAME-ACTUATOR; ML-6510ND,XRX	SNA	1
20	5	L9648	6502-001132	SADDLE; CS4N,11.6X8.8,Nylon66,BLACK	SA	1
21	5		JC61-03832A	FRAME-BASE_FEED; ML-6510ND,PC,5V,BLACK,W3	SNA	1
22	5	C3379	JC66-01262A	GEAR-FEED; ML-4550,POM M90-44,0.8,26,PURP	SA	1
23	5		JC66-02656A	ROLLER-FEED2; ML-6510ND,EPDM,SUM22+NI,6,E	SA	1
24	5		JC93-00259A	FRAME-FEED IDLE; ML-6510ND,XRX	SNA	1
25	5		JC63-02666A	GROUND-REGI; ML-6510ND,SUS,0.2,W41.3,L44.	SNA	1
26	5	C6756	JC70-40912A	SHAFT; ML-5000A,STAINLESS-ST303,6,NI,T4.	SNA	1
27	5		JC63-03079A	GROUND-TRANSFER_REAR; ML-6510ND,SUS,0.2,W	SNA	1
28	5		JC63-02964A	SHEET-GUIDE_PLATE_TR_SMALL; ML-6510ND,PET	SNA	1

7. Power Supply and FDB

Exploded View

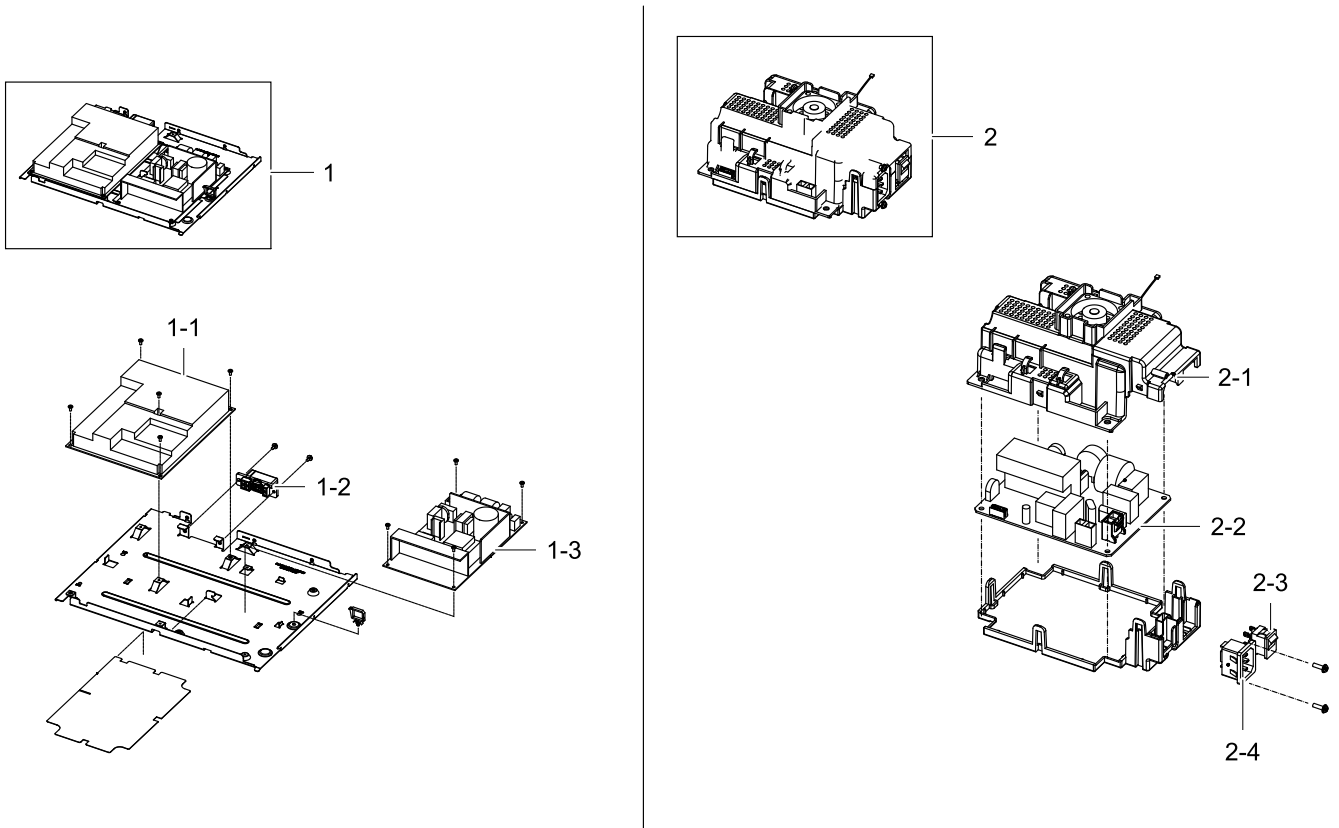

Parts List

No.	Lvl.	Material Code	Description & Specification	SNA	Qty.	Remark
1	1	JC93-00270B	FRAME-POWER SUPPLY; ML-6510ND,XRH	SNA	1	For 220V model
		JC93-00270A	FRAME-POWER SUPPLY; ML-6510ND,XRX	SNA	1	For 110V model
1-1	2	JC44-00196A	HVPS; 24V,21.6V~27.6V,MAX 5KV, MAX-2KV	SA	1	
1-2	2	JC39-01393A	HARNESS-FUSER_FR; ML-6510ND,HARNESS,UL161	SA	1	
1-3	2	JC44-00100B	SMPS-V2C; ML-6510ND,PSPN2-TYPE5-V2 R	SA	1	For 220V model
		JC44-00093B	SMPS-V1; CLP-775ND,PSPN2-TYPE5-V1 R	SA	1	For 110V model
2	1	JC93-00277B	FRAME-BOARD FUSER DRIVE; ML-6510ND,XRH	SA	1	For 220V model
		JC93-00277A	FRAME-BOARD FUSER DRIVE; ML-6510ND,XRX	SA	1	For 110V model
2-1	2	JC95-01292A	COVER-FUSER DRIVE BOARD; ML-6510ND,XRX	SNA	1	

Exploded Views and Parts List

No.	Lvl.	Material Code	Description & Specification	SNA	Qty.	Remark
2-2	2	JC44-00192A	FDB-MULTI TRIAC V2; ML-6510ND,MULTI TRIAC	SA	1	For 220V model
		JC44-00191A	FDB-MULTI TRIAC V1; ML-6510ND,MULTI TRIAC	SA	1	For 110V model
2-3	2	JC39-01389A	HARNESS-INLET; ML-6510ND,HARNESS,UL1617,2	SA	1	
2-4	2	JC39-01390A	HARNESS-FUSER_AC; ML-6510ND,HARNESS,UL161	SA	1	

8. Cassette

Exploded View

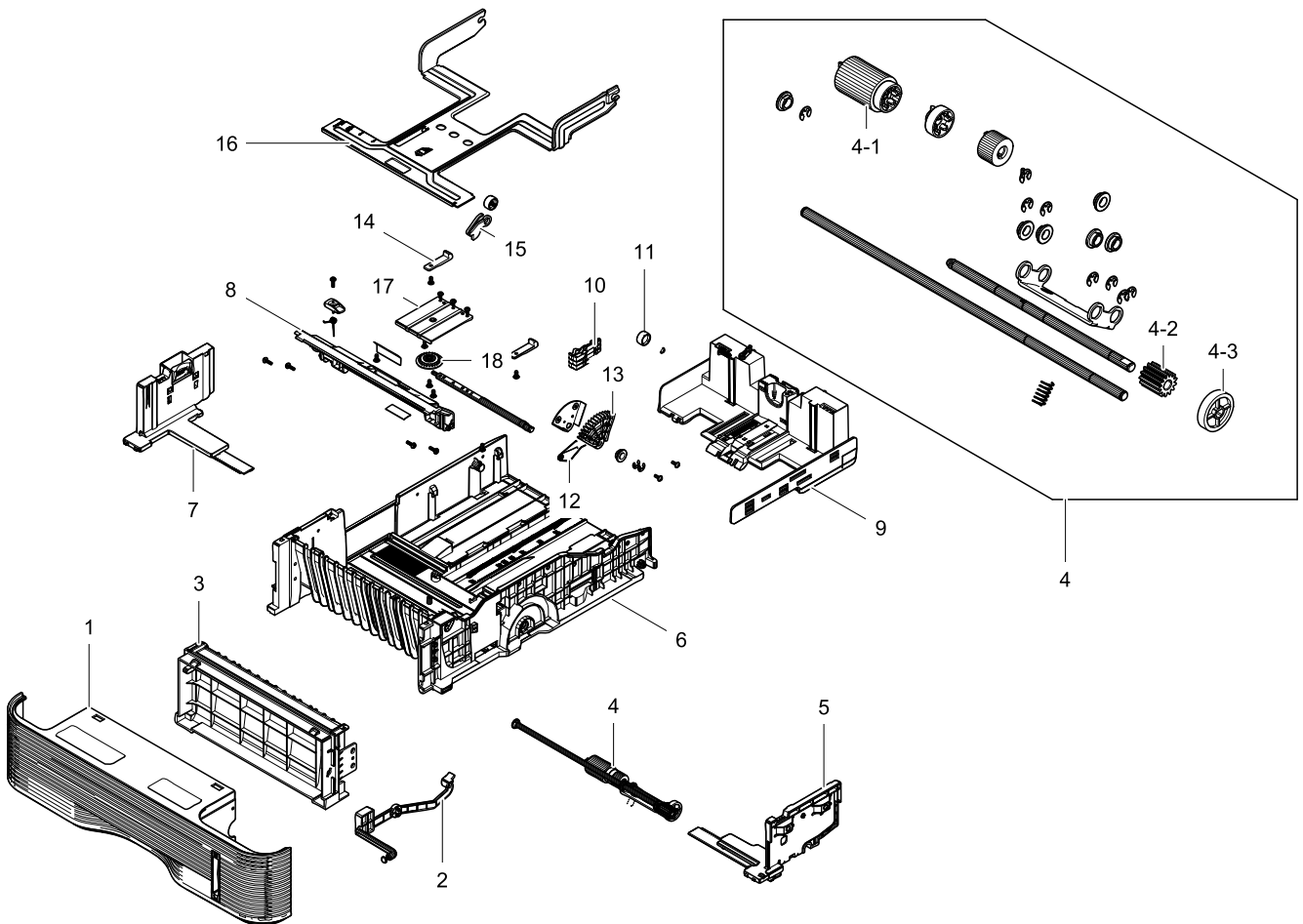

Parts List

No.	Lvl.	Loc.	Material Code	Description & Specification	SNA	Qty.
1	2		JC81-08495A	CSP-CST HANDLE CASSETTE; ML-6510ND,WAVE G	SNA	1
2	2		JC81-08891A	CSP-CST PAPER INDICATOR; ML-6510ND,SEC,SC	SNA	1
3	2		JC81-08591B	CSP-FRAME GUIDE PAPER DUMMY; ML-6510ND,AB	SNA	1
4	2		JC90-01049A	CASSETTE-RETARD; ML-6510ND,XRX	SNA	1
4-1	3	J9057	JC97-02259A	MEA UNIT-ROLLER PU; SCX-6345N/XRX,XEROX,-	SA	1
4-2	2		JC81-08477A	CSP-GEAR IDLE RETARD; ML-6510ND,POM,M90-4	SNA	1
4-3	2	I5831	JC66-01676A	GEAR-PICKUP DRIVE; SCX-6555N,POM,1,25,BLK	SA	1
5	2		JC90-01047B	CASSETTE-SIDE RIGHT; ML-6510ND,SEC	SNA	1

Exploded Views and Parts List

No.	Lvl.	Loc.	Material Code	Description & Specification	SNA	Qty.
6	2		JC81-08488B	CSP-FRAME CASSETTE; ML-6510ND,ABS / HB,HF	SNA	1
7	2		JC90-01048A	CASSETTE-SIDE LEFT; ML-6510ND,XRX	SNA	1
8	2		JC81-08479B	CSP-CAP RETARD; ML-6510ND,PC,NH-1035,Wave	SNA	1
9	2		JC90-01050B	CASSETTE-GUIDE REAR PAPER; ML-6510ND,SEC	SNA	1
10	2		JC81-08485A	CSP-DETECTOR PAPER SIZE; ML-6510ND,POM,M9	SNA	3
11	2		JC61-03882A	ROLLER-SUPPORT_CST; ML-6510ND,POM,W16,L8,	SNA	2
12	2		JC81-08486A	CSP-SPRING GROUND CASSETTE; ML-6510ND,SUS	SNA	1
13	2		JC81-08478A	CSP-GEAR LIFTING; ML-6510ND,POM,M90-44	SA	1
14	2		JC81-08602A	CSP-LOCKER GUIDE REAR; ML-6510ND,POM,M90-	SNA	2
15	2		JC81-08494A	CSP-LOCKER CASSETTE; ML-6510ND,POM,M90-44	SNA	1
16	2		JC81-08519A	CSP-PLATE KNOCK UP; ML-6510ND,SECC1.6T	SNA	1
17	2		JC61-03206A	PLATE-LEVER; CLX-9350,EGI-SECC,1.6T,73,60	SNA	1
18	2	I5678	JC66-01020A	GEAR-M_PINION 24; SCX-6345N/XRX,POM,1,24,	SA	1