

# Xerox® B205/B215 Multifunction Printer Service Manual

**xerox**™



702P07550  
July 2019  
Initial Release

Xerox® B205/B215 Multifunction Printer Service Manual

Service Documentation

Xerox® B205/B215 Multifunction Printer Service Manual

P/N 702P07550

Initial Release

July 2019

Prepared by:

Technical Communications Solutions

Xerox Ltd

Bessemer Road, Welwyn Garden City

Hertfordshire

AL7 1BU

United Kingdom

© 2017 Xerox Corporation. All Rights Reserved. Xerox®, Xerox, Design® and VersaLink® are trademarks of Xerox Corporation in the United States and/or other countries.

Other company trademarks are also acknowledged.

## NOTICE

While every care has been taken in the preparation of this manual, no liability will be accepted by Xerox Europe arising out of any inaccuracies or omissions.

All service documentation is supplied to Xerox external customers for informational purposes only. Xerox service documentation is intended for use by certified, product trained service personnel only. Xerox does not warrant or represent that it will notify or provide to such customer any future change to this documentation. Customer performed service of equipment, or modules, components or parts of such equipment may affect whether Xerox is responsible to fix machine defects under the warranty offered by Xerox with respect to such equipment. You should consult the applicable warranty for its terms regarding customer or third-party provided service.

## WARNING

**This equipment generates, uses and can radiate radio frequency energy, and if not installed and used in accordance with the instructions documentation, may cause interference to radio communications. It has been tested and found to comply with the limits for a Class A computing device pursuant to subpart J of part 15 of FCC rules, which are designed to provide reasonable protection against such interference when operated in a commercial environment. Operation of this equipment in a residential area is likely to cause interference in which case the user, at his own expense, will be required to correct the interference.**

**DANGER: Cet équipement génère, utilise et peut émettre des fréquences radio, et, s'il n'est pas installé et utilisé selon les recommandations du manuel d'instructions, peut causer des interférences aux communications radio. Il a été testé et jugé conforme aux limites des systèmes de catégorie A, conformément à la partie 15 de l'alinéa J des règlements FCC, établis pour protéger contre de telles interférences pendant le fonctionnement en milieu commercial. Dans une zone résidentielle, il peut causer des interférences; dans ce cas, l'utilisateur devra corriger le problème à ses propres frais.**



About This Manual .....	iii
How to Use this Manual .....	iv
Service Safety Summary.....	v
Reference Symbolology.....	vi
Voltage Specifications.....	vii
Health and Safety Incident Reporting .....	viii
Regulatory Specifications.....	ix
Translation of Warnings .....	x
Tag Usage.....	xi
Xerox® B215/B205 Overview .....	xii





# About This Manual

## Introduction

The Xerox® B215/B205 Service Manual is part of the multinational documentation for the Xerox® B215/B205 Multifunction Printer. It is structured in standard Xerox service documentation format. This manual is the primary document used for diagnosing, repairing, maintaining, and troubleshooting these systems. The Service Manual is the controlling publication for a service call. Information about using this document is found in the Introduction section. To ensure understanding of this product, complete the Xerox Service Training Program for this particular device.

## Organization

The Xerox® B215/B205 Multifunction Printer Service Manual is organized and defined within the following sections:

### Section 1 Service Call Procedures

This section contains procedures that determine what actions are to be taken during a service call on the machine and in what sequence they are to be completed. This is the entry level for all service calls.

### Section 2 Status Indicator RAPs

This section contains the diagnostic aids for troubleshooting the Fault Code and non-Fault Code related faults (with the exception of image quality problems).

### Section 3 Image Quality Repair Analysis Procedures

This section contains the diagnostic aids for troubleshooting image quality problems, as well as image quality specifications and image defect samples.

### Section 4 Repairs and Adjustments

This section contains the Adjustment and Repair procedures.

Repairs include procedures for removal and replacement of parts which have the following special conditions:

- When there is a personnel or machine safety issue.
- When removal or replacement cannot be determined from the exploded view of the Parts List.
- When there is a cleaning or a lubricating activity associated with the procedure.
- When the part requires an adjustment after replacement.
- When a special tool is required for removal or replacement.

Use the Repair Procedures for the correct order of removal and replacement, for warnings, cautions, and notes.

Adjustments include procedures for adjusting the parts that must be within specification for the correct operation of the system.

Use the Adjustment Procedures for the correct sequence of operation for specifications, warnings, cautions and notes.

### Section 5 Parts List

This section consists of a series of illustrations and an associated parts listing. Any part that is spared or any part that must be removed to access a spared part is illustrated. Common hardware is shown as a letter callout.

### Section 6 General Procedures and Information

This section contains general information, change tag information, and general procedures.

### Section 7 Wiring Data

This section contains Block Schematic Diagrams (BSDs), Plug/Jack locations, Voltage Specifications, and I/O Module locations and information.

## Component Names

Names of parts that appear in the procedures may not be exactly the same as the names that appear on the part or listed in the Parts List. For example: a part called the Registration Assembly may appear on the Parts List as Assembly, REGI.

## How to Use this Manual

Always start with Service Call Procedures, Section 1. Perform Initial Actions and verify the problem, then follow the directions given.

### How to Differentiate Between Machine Variants

The machine configuration will be identified in this manual by the configuration identifiers B205 and B215.

The B215 is Blue Angel certified with software configuration for up to 31 ppm capability. Refer to the User Guide, Parts List and Procedures for information specific to printer configuration.

When a procedure, parts list description or other reference is unique amongst different configurations of the machine, the appropriate configuration designator is indicated. Any artwork is also specific.

**NOTE:** *This manual services all configurations of the machine. Ignore references to options not installed on the machine.*

### Warnings, Cautions and Notes

#### **WARNING**

**A warning is used whenever an operating or maintenance procedure, practice, condition or statement, if not strictly observed, could result in personal injury.**

A translated version of all warnings is in [Translation of Warnings](#).

#### **CAUTION**

*A caution is used whenever an operation or maintenance procedure, practice, condition or statement, if not strictly observed, could result in damage to the equipment.*

**NOTE:** *A note is used where it is essential to highlight a procedure, practice, condition or statement.*

## Service Safety Summary

### General Guidelines

For qualified service personnel only: Refer also to Electrical Safety.

Avoid servicing alone: Do not perform internal service or adjustment of this product unless another person capable of rendering first aid or resuscitation is present.

Use care when servicing with power applied: Dangerous voltages may exist at several points in this product. To avoid personal injury, do not touch exposed connections and components while power is on. Disconnect power before removing the power supply shield or replacing components.

Do not wear jewelry: Remove jewelry prior to servicing. Rings, necklaces and other metallic objects could come into contact with dangerous voltages and currents.

### Electrical Safety

- Use the Power Cord supplied with the printer.
- Plug the Power Cord directly into a properly grounded electrical outlet.
- Do not use a ground adapter plug to connect the printer to an electrical outlet that does not have a ground connection terminal.
- Do not use an extension cord or power strip.
- Do not place the system in an area where people might step on the power cord.
- Do not place objects on the power cord.
- Do not block the ventilation openings. These openings are provided to prevent overheating of the printer.
- Do not drop paper clips or staples into the printer.

### Operational Safety

The printer and supplies were designed and tested to meet strict safety requirements. These include safety agency examination, approval, and compliance with established environmental standards.

Pay attention to these safety guidelines to ensure the continued, safe operation of the printer.

- Use the supplies specifically designed for your system. The use of unsuitable materials may cause poor performance and a possible safety hazard.
- Follow all warnings and instructions marked on, or supplied with, the system, options and supplies.

**NOTE:** *The Total Satisfaction Guarantee is available in the United States and Canada. Coverage may vary outside these areas; please contact your local representative for details.*

### Maintenance Safety

- Do not attempt any maintenance procedure that is not specifically described in the documentation supplied with the printer.
- Do not use aerosol cleaners. The use of supplies that are not approved may cause poor performance and could create a hazardous condition.
- Do not burn any consumables or routine maintenance items. For information on Xerox supplies recycling programs, go to [www.xerox.com](http://www.xerox.com).

### Warning Labels

Read and obey all posted warning labels. Throughout the printer, warning labels are displayed on potentially dangerous components. As you service the printer, check to make certain that all warning labels remain in place.

### Safety Interlocks

Make sure all covers are in place and all interlock switches are functioning correctly after you have completed a printer service call. If you bypass an interlock switch during a service call, use extreme caution when working on or around the printer.

### Electrostatic Discharge (ESD) Field Service Kit

The purpose of the ESD Protection Program is to preserve the inherent reliability and quality of electronic components that are handled by the Field Service Personnel. This program has been implemented as a direct result of advances in microcircuitry technology, as well as a new acknowledgment of the magnitude of the ESD problem in the electronics industry today.

This program will reduce Field Service costs that are charged to PWB failures. Ninety percent of all PWB failures that are ESD related do not occur immediately. Using the ESD Field Service Kit will eliminate these delayed failures and intermittent problems caused by ESD. This will improve product reliability and reduce callbacks.

The ESD Field Service Kit should be used whenever Printed Wiring Boards or ESD sensitive components are being handled. This includes activities like replacing or re-seating of circuit boards or connectors. The kit should also be used in order to prevent additional damage when circuit boards are returned for repair.

The instructions for using the ESD Field Service Kit can be found in GP 8 in the General Procedures section of the Service Documentation.

### Product Safety Certification

This product is certified by various NRTLs/NCBs to the safety standards listed below:

UL60950-1/CSA22.2, No. 60950-1 (USA/Canada)

IEC60950-1 (CB Scheme)

## Reference Symbology

### Safety Symbols and Terminology

The following are examples of the terminology and symbols that are used in this documentation for an Electrostatic Device Caution, Laser Warning, and general Warnings, Cautions, or Notes.

#### WARNING

**Improper operation may result in injury to a person.**



#### CAUTION

*Improper operation may result in machine damage.*



#### Laser

Indicates that Laser safety precautions must be used.



#### Hot Surface

Indicates that a surface can be hot. Use caution when reaching in the machine to avoid touching the hot surface.



#### Electrical Current

Danger label indicates where electrical currents travel when the machine is closed and operating. Use caution when reaching in the machine.



#### ESD

Certain components in this product are susceptible to damage from Electrostatic Discharge. Observe all ESD procedures to avoid component damage.



The following reference symbols are used throughout the Xerox® B215/B205 Service Documentation.

#### 1. Flag

- This symbol indicates a reference point into a circuit diagram from a RAP.

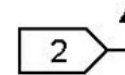

#### 2. Note

- This symbol is used to refer to notes that are found on the same page of a circuit diagram. A note is used whenever it is necessary to highlight an operating or maintenance procedure, a practice, condition, or statement.
- Hints or other information that may assist the user.



#### 3. Parts List

- This symbol, example (PL2.1), refers to the Parts List exploded view page where the part can be found.

#### 4. Adjustment

- This symbol refers to an adjustment procedure in the Repair/Adjustments section.



5. Test Point, Test Hole, Test Stake

- This symbol is used to indicate that a test point, test hole, or test stake is available for accessing the signal line. The prefix indicates whether the access is a test point (TP), test hole (TH), or test stake (TS).



6. Commoning Point

- This symbol is used to refer to a location in the machine wiring where more than two wires are connected together at a single point.



7. Arrow

- This symbol points to the location to install, gain access to, or to release a component.



## Voltage Specifications

### AC and DC Voltages

Measurements of DC voltage must be made with reference to the specified DC Common, unless some other point is referenced in a diagnostic procedure. All measurements of AC voltage should be made with respect to the adjacent return or ACN wire [Table 1](#).

**Table 1 Voltage Measurement and Specifications**

VOLTAGE	SPECIFICATION
110 to 120 VAC 60Hz	100 to 132 VAC
Neutral to Ground VAC	0 VAC (+/- 5VAC)
+5 VDC	+5.05 VDC TO +5.25 VDC
+12 VDC	+11.4 VDC TO +12.6 VDC
-12 VDC	-11.4 VDC TO -12.6 VDC
+24 VDC	+22.8VDC TO +25.2 VDC
+36 VDC	+34.2 VDC TO +37.8 VDC

### Logic Voltage Levels

Measurements of logic levels must be made with reference to the specified DC Common, unless some other point is referenced in a diagnostic procedure [Table 2](#).

**Table 2 Logic Levels**

VOLTAGE	H/L SPECIFICATIONS
+5 VDC	H= +3.00 TO +5.25 VDC, L= 0.0 TO 0.8 VDC
+24 VDC	H= +23.37 TO +27.06 VDC, L= 0.0 TO 0.8 VDC

### DC Voltage Measurements in RAPs

The RAPs have been designed so that when it is required to use the DMM to measure a DC voltage, the first test point listed is the location for the red (+) meter lead and the second test point is the location for the black meter lead. For example, the following statement may be found in a RAP:

**There is +5 VDC from TP7 to TP68.**

In this example, the red meter lead would be placed on TP7 and the black meter lead on TP68.

Another example of a statement found in a RAP might be:

**There is -15 VDC from TP21 to TP33.**

In this example, the red meter lead would be placed on TP21 and the black meter lead would be placed on TP33.

If a second test point is not given, it is assumed that the black meter lead may be attached to the copier frame.

# Health and Safety Incident Reporting

## I. Summary

This section defines requirements for notification of health and safety incidents involving Xerox products (equipment and materials) at customer locations.

## II. Scope

Xerox Corporation and subsidiaries worldwide.

## III. Objective

To enable prompt resolution of health and safety incidents involving Xerox products and to ensure Xerox regulatory compliance.

## IV. Definitions

Incident:

An event or condition occurring in a customer account that has resulted in injury, illness or property damage. Examples of incidents include machine fires, smoke generation, physical injury to an operator or service representative. Alleged events and product conditions are included in this definition.

## V. Requirements

Initial Report:

1. Xerox organizations shall establish a process for individuals to report product incidents to Xerox Environment Health & Safety within 24 hours of becoming aware of the event.
2. The information to be provided at the time of reporting is contained in Appendix A (Health and Safety Incident Report involving a Xerox product).
3. The initial notification may be made by any of the following methods:
  - For incidents in North America and Developing Markets West (Brazil, Mexico, Latin American North and Latin American South):
    - Phone\* Xerox EH&S at: 1-800-828-6571.
    - Electronic mail Xerox EH&S at: USA.XEROX.EHS@xerox.com.
    - Fax Xerox EH&S at: 1-585-216-8817 [intelnet 8\*219-68817].
  - For incidents in Europe and Developing Markets East (Middle East, Africa, India, China and Hong Kong):
    - Phone\* Xerox EH&S at: +44 (0) 1707 353434 [intelnet 8\*668 3434]
    - Electronic mail Xerox EH&S at: EH&S-Europe@xerox.com
    - Fax Xerox EH&S at: +44 (0) 1707 353914 [intelnet 8\*668 3914]

\*Initial notification made by phone must be followed within 24 hours by a completed incident report and sent to the indicated electronic mail address or fax number.

**NOTE:** If sending a fax, please also send the original via internal mail.

Responsibilities for resolution:

1. Business Groups/Product Design Teams responsible for the product involved in the incident shall:
  - a. Manage field bulletins, customer correspondence, product recalls, safety retrofits.
  - b. Fund all field retrofits.
2. Field Service Operations shall:
  - a. Preserve the Xerox product involved and the scene of the incident inclusive of any associated equipment located in the vicinity of the incident.
  - b. Return any affected equipment/part(s) to the location designated by Xerox EH&S and/or the Business Division.
  - c. Implement all safety retrofits.
3. Xerox EH&S shall:
  - a. Manage and report all incident investigation activities.
  - b. Review and approve proposed product corrective actions and retrofits, if necessary.
  - c. Manage all communications and correspondence with government agencies.
  - d. Define actions to correct confirmed incidents.

## Regulatory Specifications

Xerox has tested this product to electromagnetic emission and immunity standards. These standards are designed to mitigate interference caused or received by this product in a typical office environment.

### United States (FCC Regulations)

The Xerox® B215/B205 has been tested and found to comply with the limits for a Class A digital device pursuant to Part 15 of the FCC Rules. These limits are designed to provide reasonable protection against harmful interference in a commercial installation. This equipment generates, uses, and can radiate radio frequency energy. If it is not installed and used in accordance with these instructions, it may cause harmful interference to radio communications. Operation of Class A equipment in a residential area is likely to cause harmful interference in which case the user will be required to correct the interference at his/her own expense. There is no guarantee that interference will not occur in a particular installation.

If this equipment does cause harmful interference to radio or television reception, which can be determined by turning the equipment Off and On, the user is encouraged to try to correct the interference by one or more of the following measures:

- Reorient or relocate the receiver.
- Increase the separation between the equipment and receiver.
- Connect the equipment into an outlet on a circuit different from that to which the receiver is connected.
- Consult the dealer or an experienced radio/television technician for help.

Any changes or modifications not expressly approved by Xerox could void the user's authority to operate the equipment. To ensure compliance with Part 15 of the FCC rules, use shielded interface cables.

### Canada (Regulations)

This Class A digital apparatus complies with Canadian ICES-003.

Cet appareil numérique de la classe A est conforme à la norme NMB-003 du Canada.

## European Union

CE Mark



The CE mark applied to this product symbolizes Xerox's declaration of conformity with the following applicable Directives of the European Union as of the dates indicated:

**Figure 1 CE Symbol**

February 26, 2014: Low Voltage Directive 2014/35/EU

February 26, 2014: Electromagnetic Compatibility Directive 2014/30/EU

April 16, 2014: Radio Equipment Directive 2014/53/EU

This product, if used properly in accordance with the user's instructions, is neither dangerous for the consumer nor for the environment.

To ensure compliance with European Union regulations, use shielded interface cables.

A signed copy of the Declaration of Conformity for this product can be obtained from Xerox.



## Translation of Warnings

### WARNING

Switch off the electricity to the machine. Disconnect the power cord from the customer supply while performing tasks that do not need electricity. Electricity can cause death or injury. Moving parts can cause injury.

**DANGER:** Mettez la machine hors tension. Déconnectez le cordon d'alimentation de l'alimentation du client lorsque vous réalisez des tâches qui ne nécessitent pas d'électricité. L'électricité peut être à l'origine de blessures, voire d'un accident mortel. Les pièces amovibles peuvent être à l'origine de blessures.

**AVVERTENZA:** Spegner la macchina. Scollegare il cavo di alimentazione dall'alimentatore quando si eseguono attività che non richiedono elettricità. L'elettricità può causare morte o lesioni personali. Le parti in movimento possono causare lesioni personali.

**VORSICHT:** Schalten Sie die Stromversorgung der Maschine ab. Ziehen Sie das Stromkabel ab, wenn Sie Aufgaben ausführen, für die keine Stromversorgung benötigt wird. Stromschläge können Todesfällen oder Verletzungen verursachen. Bewegliche Teile können zu Verletzungen führen.

**AVISO:** Apague la electricidad de la máquina. Desconecte el cable de alimentación eléctrica de la toma de pared mientras esté realizando tareas que no necesiten corriente. La electricidad puede causar daños o la muerte. Las partes móviles pueden causar daños.

### WARNING

Do not work in a confined space. 1 m (39 inches) space is needed for safe working.

**DANGER:** Ne pas travailler dans un espace restreint. 1 mètre d'espace est nécessaire pour un dépannage en toute sécurité.

**AVVERTENZA:** Non lavorare in uno spazio limitato; è necessario uno spazio di almeno un metro attorno alla macchina per la sicurezza dell'operatore.

**VORSICHT:** Nur mit ausreichendem Bewegungsspielraum (1 m) arbeiten.

**AVISO:** No trabaje en un espacio reducido. Se necesita 1 metro de espacio para trabajar con seguridad.

### WARNING

Use safe handling procedures when removing the module. Refer to GP 16. The module is heavy.

**DANGER:** Conformez-vous aux procédures de manipulation de sécurité pour le retrait du module. Reportez-vous à GP 16. Le module est lourd.

**AVVERTENZA:** Utilizzare procedure di gestione sicure durante la rimozione del modulo. Vedere GP 16. Il modulo è pesante.

**VORSICHT:** Verwenden Sie sichere Vorgehensweisen zum Entfernen des Moduls. Siehe auch GP 16. Das Modul ist sehr schwer.

**AVISO:** Utilice los procedimientos de seguridad cuando elimine el módulo. Consulte el GP 16. El módulo es pesado.

### WARNING

Follow the service procedure exactly as written. Use of controls or adjustments other than those specified in this manual, may result in an exposure to invisible laser radiation. During servicing, the invisible laser radiation can cause eye damage if looked at directly.

**DANGER:** Les procédures de dépannage doivent être suivies à la lettre. Si les réglages ou vérifications ne sont pas effectués suivant les instructions de ce manuel, il peut y avoir un risque d'exposition dangereuse au faisceau laser. Celui-ci peut provoquer des lésions oculaires s'il est observé directement.

**AVVERTENZA:** Eseguire la procedura di servizio esattamente come descritto. L'utilizzo di dispositivi di controllo o di registrazione diversi da quelli riportati in questo manuale potrebbe comportare un'esposizione a radiazioni laser invisibili. Tali radiazioni possono danneggiare gli occhi se si guarda direttamente il fascio laser durante gli interventi di servizio.

**VORSICHT:** Die Wartungsarbeiten genau den Anweisungen entsprechend durchführen. Der Umgang mit Steuer- oder Bedienelementen, deren Verwendung nicht ausdrücklich in diesem Handbuch angewiesen wurde, kann dazu führen, dass unsichtbare Laserstrahlung frei gesetzt wird. Direkter Blickkontakt mit dem Laserstrahl kann bleibende Augenschäden verursachen.

**AVISO:** Siga los procedimientos de mantenimiento tal como están descritos. El uso de controles o ajustes no especificados en este manual puede tener como resultado la exposición a radiación láser invisible. Durante las operaciones de mantenimiento, la radiación de láser invisible puede causar daños en los ojos si se mira directamente a ella.

### WARNING

USA and Canada. Do not install this machine in a hallway or exit route that does not have 1.12 m (44 inches) of space additional to the normal space requirements in front of the machine. To conform with fire regulations this additional 1.12 m (44 inches) of space is needed in front of the machine in hallway and exit routes.

**DANGER:** États-Unis et Canada. Si cette machine est installée dans un couloir ou une voie de sortie, 1,12 m (44 pouces) d'espace supplémentaire à l'espace normal doit être disponible devant la machine conformément aux normes de sécurité d'incendie.

**AVVERTENZA:** N/A

**VORSICHT:** N/A

**AVISO:** Estados Unidos y Canadá. No instale esta máquina en un corredor o ruta de salida que no tenga 1.12 m (44 pulgadas) de ancho delante de la máquina, sin incluir el espacio que ocupe la máquina. Este espacio adicional de 1.12 m (44 pulgadas) delante de la máquina en corredores y rutas de salida es necesario para cumplir los requisitos de las normas sobre incendios.

## WARNING

Use only Xerox materials and components. This product is safety certified using Xerox materials and components. The use of non Xerox materials and components may invalidate the safety certificate.

**DANGER:** N'utilisez que des matières premières et des composants Xerox. La sécurité du produit est assurée dans le cadre de son utilisation avec des matières premières et des composants Xerox. L'utilisation de matières premières et de composants autres que ceux de Xerox risque d'invalider le certificat de sécurité.

**AVVERTENZA:** Utilizzare solo materiali e componenti Xerox per avvalersi della certificazione di protezione. L'utilizzo di materiali e componenti non Xerox può rendere nulla la certificazione di protezione.

**VORSICHT:** Verwenden Sie nur Materialien und Komponenten von Xerox. Dieses Produkt besitzt die Sicherheitszertifizierung bei Verwendung von Xerox-Materialien und -Komponenten. Die Verwendung von Materialien und Komponenten anderer Hersteller setzt möglicherweise das Sicherheitszertifikat außer Kraft.

**AVISO:** Utilice solo los materiales y componentes Xerox. Este producto dispone de un certificado de seguridad si se utilizan los materiales y componentes Xerox. Este certificado de seguridad no será válido si se utilizan materiales y componentes que no sean de Xerox.

## WARNING

Do not touch the fuser while it is hot.

**DANGER:** Ne pas toucher au four pendant qu'il est encore chaud.

**AVVERTENZA:** Non toccare il fonditore quando è caldo.

**VORSICHT:** Fixierbereich erst berühren, wenn dieser abgekühlt ist.

**AVISO:** No toque el fusor mientras está caliente.

## Tag Usage

### Tags

If different parts or actions exist because of a modification, the Tag number will identify the appropriate part or action.

- Example 1). Tag xx: PWB...
- Example 2) PWB (Tag xx)...

### Tag Symbols

This symbol is used to show a particular part or area of a figure that has been modified by the Tag number within the circle.

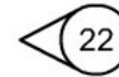

This symbol is used to show a particular part or area of a figure that has not been modified by the Tag number within the circle.



This symbol is used to show a Tag change has modified an area of the terminal.



This symbol is used to show a Tag change has not modified an area of the terminal.



# Xerox® B215/B205 Overview

Refer to the Xerox® B215/B205 User Guide, Product Configuration Section 1 for detailed descriptions and illustrations of Control Panel functions, machine features and options, [Table 1](#).

**Table 1 Product Configurations**

Component	B205	B215
Automatic Document Feeder - 40 Sheets	Standard	Standard
Paper Tray - 250 Sheets	Standard	Standard
Manual Feed Slot - 1 sheet	Standard	Standard
Output Tray - 120 Sheets	Standard	Standard
AirPrint	Standard	Standard
Google Cloud Print	Standard	Standard
Network Printing	Standard	Standard
Copy	Standard	Standard
Scan	Standard	Standard
Fax	N/A	Standard
E-mail	Standard	Standard
USB Device	Standard	Standard
Wi-Fi	Standard	Standard
Wi-Fi Direct™	Standard	Standard

---

# 1 Service Call Procedures

**Call Flow**

Service Call Overview ..... 1-3  
Safety Precautions ..... 1-3  
SCP 01 Introduction to Service Call Procedures ..... 1-4  
SCP 02 Initial Actions..... 1-4  
SCP 03 Corrective Actions..... 1-5  
SCP 04 Final Actions ..... 1-5

**System/Subsystem Maintenance**

HFSI's ..... 1-6



## Service Call Overview

This section provides an overview of actions a service technician should take when servicing a machine. Refer to the checklist below as a guide for steps to take when troubleshooting problems with the printer. Follow all precautions listed in the Safety Precautions section.

1. Identify the problem
  - Verify that the problem exists.
  - Record any error codes.
  - Print both customer and test prints.
  - Make note of any image quality problems in the test prints.
  - Observe if any unusual odors or noises coming from the printer.
  - Ensure that the AC input power is within specifications.
  - From the Diagnostics Mode, print an Error Information Report.
2. Inspect and clean the printer
  - Disconnect and inspect the power cord.
  - Inspect the interior of the printer. Remove any debris or contamination.
  - Inspect the printer for damaged wires, loose connections toner leakage or any other worn or damaged parts.
3. Find the cause of the problem.
  - Use troubleshooting procedures to find the root cause of the problem
  - Use diagnostics to check the printer and components
  - Use the BSDs to locate test points.
  - Take voltage readings as instructed in the troubleshooting procedure.
4. Correct the problem
  - Use the Parts List to locate part numbers.
  - Use the Repair Procedures to replace parts.
5. Final Actions
  - Test the printer to verify that the problem has been corrected and that there are no additional problems.

## Diagnostic Mode

The Xerox® B215/B205 has built-in diagnostics to test components, display status and some NVM access. The diagnostic tests are accessed through the Control Panel. Refer to the User Guide for detailed instructions on using the Control Panel buttons and menus. Refer to Section 6 for diagnostic test menus.

## Safety Precautions

Ensure that all Cautions and Warnings detailed in the service procedures are followed when servicing the machine.

Failure to follow the following instructions could cause an electrical shock or fire hazard.

- Only use the Power Cord supplied with this product.  
Do not allow the Power Cord to become twisted, bent, or damaged.
- Do not allow liquids to spill on or into the machine.
- Do not allow paper clips, pins or other objects to fall into the machine.
- When replacing the SMPS PWB wait 5 minutes after unplugging the Power Cord before removing the PWB. This allows the PWB to discharge, preventing electrical shock.

### Laser Safety

- The Laser system is designed so there is never human access to the Laser radiation during normal operation, user maintenance, or service maintenance.
- Do not bypass or disable any laser safety devices or attempt to service the Laser.

## SCP 01 Introduction to Service Call Procedures

### Purpose

Service Call Procedures (SCP) are the guide to performing a service call on the Xerox® B215/B205 Multifunction Printer.

The Operator has been trained in the use of the Xerox® B215/B205 User Guide, Troubleshooting in Section 12, to help analyze the fault. The Troubleshooting section directs the Operator in the following:

- Faults indicated by a Status Code or UI message
- Web Registration Module problem solving
- Image quality defect initial actions
- Image quality defect diagnosis
- Image quality fault code problem solving

If the Operator is unable to resolve the problem, they initiate a service call by contacting The Xerox Support Center at: [www.xerox.com/support](http://www.xerox.com/support).

### SCP 02 Initial Actions

The purpose of Initial Actions is to gather information and organize the service call. The customer is questioned, and the complaint is verified.

All anticipated service actions are classified as primary or secondary. Primary service actions are those actions that directly relate to the reason for the call.

### SCP 03 Corrective Actions

Corrective Actions are the diagnostic and repair activities required to correct the problem that initiated the service call (primary actions), as well as any other problems or secondary actions identified in Initial Actions.

When performing maintenance actions, either scheduled or unscheduled, always consider the customer's print schedule and whether they are in a highly time-sensitive print run, or in a less time-sensitive print run. The customer's current mode of operation will determine the service actions on Unscheduled Maintenance (UM) calls. The objective of all service actions is to integrate the Xerox service process with the customer's printing process in a manner that maximizes customer equipment up-time and productivity during periods of time-sensitive print runs.

This is one of the tenets of Overall Equipment Effectiveness (OEE).

## SCP 02 Initial Actions

### Purpose

The purpose of the Initial Actions is to help organize the service call. Customer input, machine observations and print samples are all used to gather information about the condition of the system. Gather a list of symptoms, error codes, or other information concerning the problem that the customer may provide. This information may help identify and correct intermittent or unusual problems.

During each service call, perform all Primary Maintenance Activities, then decide if Secondary Maintenance Activities are needed.

- Primary Maintenance Activities are actions performed which relate to the customer's complaint.
- Secondary Maintenance Activities are any activities identified during the service call which are not related to the primary activity, but may lead to a future service call or otherwise negatively affect the customer's satisfaction.

Before deciding to perform any secondary maintenance, first determine if the customer is in a time-sensitive print run. If so, perform only those actions required to ensure completion of the run, and defer all other actions-- including HFSI's that are not required to complete the print run. The objective of any service call during a time-sensitive print run is to return the system to production as soon as possible.

Before performing any secondary maintenance actions, first inform the customer of what secondary actions are indicated and the system down time required. You may want to return on another, mutually agreeable time to perform the secondary maintenance activity/actions.

Likewise, for any secondary maintenance actions deferred during a time-sensitive print run, inform the customer of what remaining secondary actions are indicated and the down time required. Coordinate with the customer's print schedule to determine a mutually-agreeable time frame to complete these activities.

### Procedure

1. Discuss the problem with the customer.
2. If the problem is IQ related, run prints to verify that the problem is present.
3. Determine if there are any bulletins, or Eureka tips relating to the Customer's primary problem. Bulletins are on Eureka and are searchable with SearchLite.
4. When all information has been gathered, and all anticipated service actions have been classified as primary or secondary, proceed to Corrective Actions.

## SCP 03 Corrective Actions

### Purpose

The Corrective Actions procedure will direct you to the appropriate section of the service manual to diagnose and repair the primary problem, and provides you with the information required to identify any due HFSI items.

### Procedure

1. Using the Supplies Information Report, review the HFSI's in to identify any due HFSI's. Clean/replace **only** components that are due and may be contributing to the problem.

### System Fault Analysis

1. If the problem is a machine fault, determine if the type of fault code.
  - a. If the problem is a Printer fault code:
    - Enter Diagnostic Mode and print an Error Information Report.
    - Check for associated fault codes that have the same or nearly the same time stamp as the primary fault code.
    - Troubleshoot fault codes with the lowest chain number first.
2. If the problem is IQ related, refer to Section 3, Image Quality.
3. When the primary problem is resolved, proceed to Final Actions.

## SCP 04 Final Actions

### Purpose

Final Actions verify total operation of the machine, ensures that the HFSI's are completed, and provides a Machine Site Checklist to complete the call.

### Procedure

1. Print a Sample Job and verify with the operator the total operation of the machine. If any problems are identified, return to SCP 03 Corrective Actions.
2. To complete the service call.
  - Check the customer consumables.
  - Service tools are properly stored and secured.
  - Verify the access to the circuit breakers is clear.
  - Check that all of the covers are in place and closed.
  - Verify that all mandatory retrofits have been installed. If required, set a time with the customer to install any mandatory retrofits.



## HFSI's

### Customer and Service HFSI's

As with other CSE actions, these actions should be performed according to customer run requirements. Some actions may be deferred to a Xerox Initiated activity, taking into consideration any risks with deferring those actions.

- Customer Maintenance Log Book (operator) - tracking sheet **Service Maintenance Intervals**.

If necessary, and if the customer agrees, clean/replace any secondary HFSI's that are due or may cause a return service call.

**Table 1 Customer/Service HFSI's**

HSFI Item	Action	Customer	Service	Reference	Interval	Notes
Toner Cartridge	Replace	X		N/A	1,500 standard / 3,000 high yield (approx. impressions)	
Drum Cartridge (OPC)	Replace	X		N/A	10,000	
Fuser	Replace		X	REP 5.1	100,000	
Transfer Roller	Replace		X	REP 4.4	100,000	
Forward Roller	Replace		X	REP 4.14	50,000	
Retard Roller	Replace		X	REP 6.1	50,000	
Pick-up Roller	Replace		X	REP 4.14	50,000	
ADF Feed Roller	Replace		X	REP 1.5	20,000	
ADF Retard Pad	Replace		X	REP 1.7	20,000	

## 2 Status Indicator RAPs

01-150 Front Door Open RAP .....	2-3	20-100 Fax Communication Error RAP .....	2-31
02-100, 200 USB Error RAP .....	2-3	20-120 Scanning Error RAP .....	2-32
03-410 Paper Mismatch at Tray 1 RAP .....	2-4	20-300 Incompatible (FAX) RAP .....	2-32
03-450 Paper Mismatch at Manual Feed Slot RAP .....	2-4	20-400 / 410 Line RAP .....	2-33
03-900 Main PWB Motor Control Chip RAP .....	2-5	20-500 Memory Full RAP .....	2-33
04-500 Drive Motor Start RAP .....	2-5	20-600 No Answer RAP .....	2-34
05-100 / 900 Paper Jam in Automatic Document Feeder (ADF) RAP .....	2-6		
05-500 DADF Jam RAP .....	2-7		
05-920 DADF Top Cover Open RAP .....	2-8		
06-100 / 200 LSU Motor RAP .....	2-8		
07-110 Paper Tray 1 Empty RAP .....	2-9		
07-130 Paper Jam in Tray 1 RAP .....	2-10		
07-500 Manual Feed Slot Paper Empty RAP .....	2-11		
07-530 Paper Feed - Manual Feed Slot RAP .....	2-12		
07-600 Paper Tray Empty RAP .....	2-13		
08-100 Paper Feed - Tray 1 RAP .....	2-13		
08-500 Paper Jam in Exit Area RAP .....	2-14		
08-600 Paper Jam in Duplex Area RAP .....	2-15		
08-700 Output Bin Full Fault .....	2-15		
09-100 Toner Cartridge Near End of Life RAP .....	2-16		
09-200 Toner Cartridge Empty RAP .....	2-16		
09-300 Imaging Unit Near End of Life RAP .....	2-17		
09-400 Imaging Unit End of Life RAP .....	2-17		
09-500 Toner Cartridge Not Installed RAP .....	2-18		
09-600, 09-900 Imaging Unit Not Installed or Invalid RAP .....	2-18		
09-800 Incompatible Toner Cartridge RAP .....	2-19		
10-100 Fuser Temperature (Open) RAP .....	2-19		
10-200, 10-300 Fuser Temperature Error RAP .....	2-20		
15-100, 15-110 Scan to E-mail RAP .....	2-21		
15-130, 15-340 Mail Too Large RAP .....	2-21		
15-140 / 150 Invalid Email / Group Address RAP .....	2-22		
15-300 Network Connection Failure RAP .....	2-22		
15-310 / 600 Authentication Failure RAP .....	2-23		
15-320 / 330 Mail Server Connection Failure RAP .....	2-23		
15-400 LDAP Communication Failure RAP .....	2-24		
15-410, 15-420 LDAP Search Failure RAP .....	2-24		
15-510 Scan Error RAP .....	2-25		
15-700 DNS Error RAP .....	2-25		
17-100 IP Conflict Error RAP .....	2-26		
17-110, 17-130, 17-140, 17-150, 17-200, 17-510, 17-600, 17-610 Network Controller RAP .....	2-26		
17-310 Communication Error (Main PWB to Wireless PWB) RAP .....	2-27		
17-562 Auto-Registration Process Fails to Communicate Error RAP .....	2-28		
17-563 Machine Fails to Communicate with Xerox Edge Server Error RAP .....	2-28		
17-700 / 710 BOOTP Error RAP .....	2-29		
17-800 / 810 DHCP Error RAP .....	2-29		
17-900 802.1X Network Authentication Error RAP .....	2-30		
17-910 Firmware Upgrade RAP .....	2-30		



## 01-150 Front Door Open RAP

BSD-ON:BSD 1

### Control Panel Fault Displayed

B205: Door Open

B215: Device Front Door is Open

The front door is open or the Front Cover Latched Sensor is defective.

### WARNING

**Do not perform repair activities with the power on or electrical power supplied to the machine. The machine could activate and cause serious personal injury when the power is on or electrical power is supplied.**

**DANGER: Ne pas effectuer de dépannage avec le contact principal activé ou avec l'alimentation électrique appliquée à la machine: celle-ci pourrait démarrer et causer de graves blessures.**

**AVVERTENZA: Non effettuare alcuna riparazione con la macchina accesa o con l'alimentazione elettrica inserita. La macchina potrebbe avviarsi all'improvviso e causare gravi ferite.**

**VORSICHT: Es dürfen keine Reparaturarbeiten durchgeführt werden, solange das Gerät eingeschaltet oder mit der Stromquelle verbunden ist. Das Gerät kann u.U in den Aktiv-Zustand übergehen und somit erhebliche körperliche Schäden verursachen.**

**AVISO: No realice reparaciones con la máquina encendida o conectada a la corriente. La máquina podría activarse y ocasionar daños personales graves.**

### Procedure

Check the Front Door Open Switch operation on the HVPS PWB. **The switch is good.**

Y N

- Check CN100, FFC, is fully seated in the connector on the HVPS PWB and Main Controller, CN12.
- Install a new HVPS PWB, PL 4.1 Item 2.

Check the FFC connection between the Main PWB, CN12 and the HVPS, CN100. **The connection is secure.**

Y N

- Check that there is no contamination present.
- Check for broken or defective wires or cables.
- Install a new Main PWB, PL 1.1 Item 4.

Install a new Main PWB, PL 1.1 Item 4.

## 02-100, 200 USB Error RAP

BSD-ON:BSD 1

### Control Panel Fault Displayed

**02-100** Invalid/Unknown USB device.

B205: Invalid USB device

B215: Incompatible USB Device has been Detected

**02-200** Check USB memory.

B205: NA

B215: USB Memory is Full

### WARNING

**Do not perform repair activities with the power on or electrical power supplied to the machine. The machine could activate and cause serious personal injury when the power is on or electrical power is supplied.**

**DANGER: Ne pas effectuer de dépannage avec le contact principal activé ou avec l'alimentation électrique appliquée à la machine: celle-ci pourrait démarrer et causer de graves blessures.**

**AVVERTENZA: Non effettuare alcuna riparazione con la macchina accesa o con l'alimentazione elettrica inserita. La macchina potrebbe avviarsi all'improvviso e causare gravi ferite.**

**VORSICHT: Es dürfen keine Reparaturarbeiten durchgeführt werden, solange das Gerät eingeschaltet oder mit der Stromquelle verbunden ist. Das Gerät kann u.U in den Aktiv-Zustand übergehen und somit erhebliche körperliche Schäden verursachen.**

**AVISO: No realice reparaciones con la máquina encendida o conectada a la corriente. La máquina podría activarse y ocasionar daños personales graves.**

### Procedure

Perform the steps that follow:

1. Switch off, then switch on the machine.
2. Ensure that the customer is using a valid USB device with sufficient free file space.
3. Check the wiring between the USB host and the Main PWB, CN1.
4. If the fault persists, install a new Main PWB, PL 1.1 Item 4.

**NOTE:** Be aware, the part number for the Main PWB-B215 and Main PWB-B205 are different.

## 03-410 Paper Mismatch at Tray 1 RAP

BSD-ON:[BSD 1](#)

### Control Panel Fault Displayed

B205: Tray 1 Paper Mismatch

B215: Check the Paper in Tray 1

The size setting for the Paper Tray does not match the paper size loaded in the tray.

### Initial Actions

- Check the media size settings for the tray from the Control Panel.
- Adjust the Paper Tray Guides to match the size of the paper that is loaded into the tray.
- Place the correct size paper into the tray for the tray size setting.

### Procedure

1. Switch off, then switch on the machine
2. If the fault persists, install a new Main PWB, [PL 1.1 Item 4](#).

## 03-450 Paper Mismatch at Manual Feed Slot RAP

BSD-ON:[BSD 1](#)

### Control Panel Fault Displayed

B205: Manual Paper Mismatch

B215: Check the Paper in the Bypass Tray

The size setting for the Manual Feed Slot does not match the paper size loaded.

### Initial Actions

- Check the media size settings for the tray from the Control Panel.
- Adjust the Paper Tray Guides to match the size of the paper that is loaded into the tray.
- Place the correct size paper into the tray for the tray size setting.

### Procedure

1. Switch off, then switch on the machine
2. The fault persists, install a new Main PWB, [PL 1.1 Item 4](#).

## 03-900 Main PWB Motor Control Chip RAP

BSD-ON: [BSD 1](#)

### Control Panel Fault Displayed

B205: UI Error

B215: Communication Error

The Motor Control Chip on the Main PWB is not functioning normally.

### Procedure

1. Switch off, then switch on the machine
2. The fault persists, install a new Main PWB, [PL 1.1 Item 4](#).

## 04-500 Drive Motor Start RAP

BSD-ON: [BSD 1](#)

### Control Panel Fault Displayed

B205: Motor error turn off then on

B215: Device Error

The front door is open or the Front Cover Latched Sensor is defective.

The Main Drive (BLDC) Motor did not start within the specified time after the ready signal was sent.

### Initial Actions

- Switch off, then switch on the machine.

### WARNING

**Do not perform repair activities with the power on or electrical power supplied to the machine. The machine could activate and cause serious personal injury when the power is on or electrical power is supplied.**

**DANGER: Ne pas effectuer de dépannage avec le contact principal activé ou avec l'alimentation électrique appliquée à la machine: celle-ci pourrait démarrer et causer de graves blessures.**

**AVVERTENZA: Non effettuare alcuna riparazione con la macchina accesa o con l'alimentazione elettrica inserita. La macchina potrebbe avviarsi all'improvviso e causare gravi ferite.**

**VORSICHT: Es dürfen keine Reparaturarbeiten durchgeführt werden, solange das Gerät eingeschaltet oder mit der Stromquelle verbunden ist. Das Gerät kann u.U in den Aktiv-Zustand übergehen und somit erhebliche körperliche Schäden verursachen.**

**AVISO: No realice reparaciones con la máquina encendida o conectada a la corriente. La máquina podría activarse y ocasionar daños personales graves.**

### Procedure

Enter Diagnostic Mode, [GP 1](#), [[DC330](#), [\[100\] Main BLDC Motor](#)] to start the motor. **The motor rotates.**

Y N

Remove the Right Cover [REP 2.2](#), then check the motor connector on the Main PWB. **The connector on the Main PWB is connected correctly.**

Y N

- Check that there is no contamination present
- Check for broken and defective wires or cables.
- Securely reconnect the motor connector.

Manually rotate the Main Drive Unit, [PL 4.6 Item 18](#). **The Main Drive Motor rotates freely.**

Y N

Install a new Main Drive Unit, [PL 4.6 Item 18](#).

The Main PWB is defective.

- Install a new Main PWB, [PL 1.1 Item 4](#).

## 05-100 / 900 Paper Jam in Automatic Document Feeder (ADF) RAP

BSD-ON:[BSD 2](#)

### Control Panel Fault Displayed

**05-100** DADF Jam1

B205: Jam at document feeder

B215: Jam in the Document Feeder

**05-900** DADF Jam0

B205: Jam at document feeder

B215: Jam in the Document Feeder

The machine has detected a paper jam in the Automatic Document Feeder (ADF).

### WARNING

**Do not perform repair activities with the power on or electrical power supplied to the machine. The machine could activate and cause serious personal injury when the power is on or electrical power is supplied.**

**DANGER: Ne pas effectuer de dépannage avec le contact principal activé ou avec l'alimentation électrique appliquée à la machine: celle-ci pourrait démarrer et causer de graves blessures.**

**AVVERTENZA: Non effettuare alcuna riparazione con la macchina accesa o con l'alimentazione elettrica inserita. La macchina potrebbe avviarsi all'improvviso e causare gravi ferite.**

**VORSICHT: Es dürfen keine Reparaturarbeiten durchgeführt werden, solange das Gerät eingeschaltet oder mit der Stromquelle verbunden ist. Das Gerät kann u.U in den Aktiv-Zustand übergehen und somit erhebliche körperliche Schäden verursachen.**

**AVISO: No realice reparaciones con la máquina encendida o conectada a la corriente. La máquina podría activarse y ocasionar daños personales graves.**

### Initial Actions

- Remove jammed sheets from the document feeder and paper path. Refer to the Xerox® B215/B205 User Guide, Section 11 for jam clearance instructions.
- If necessary, power the machine Off then On to clear the fault message.
- Open the top cover of the Document Feeder and check the Feed Roll for contamination or wear.

## WARNING

Do not perform repair activities with the power on or electrical power supplied to the machine. The machine could activate and cause serious personal injury when the power is on or electrical power is supplied.

**DANGER:** Ne pas effectuer de dépannage avec le contact principal activé ou avec l'alimentation électrique appliquée à la machine: celle-ci pourrait démarrer et causer de graves blessures.

**AVVERTENZA:** Non effettuare alcuna riparazione con la macchina accesa o con l'alimentazione elettrica inserita. La macchina potrebbe avviarsi all'improvviso e causare gravi ferite.

**VORSICHT:** Es dürfen keine Reparaturarbeiten durchgeführt werden, solange das Gerät eingeschaltet oder mit der Stromquelle verbunden ist. Das Gerät kann u.U in den Aktiv-Zustand übergehen und somit erhebliche körperliche Schäden verursachen.

**AVISO:** No realice reparaciones con la máquina encendida o conectada a la corriente. La máquina podría activarse y ocasionar daños personales graves.

### Procedure

Inspect the Paper Feed Sensor PWB, [PL 4.4 Item 20](#), for damage or contamination. Remove any debris from the sensor.

Enter Diagnostic Mode, [GP 1](#), [[DC330](#), [[102](#)] [Feed Sens](#)] to test the Paper Feed Sensor. **The sensor is OK.**

Y N

- Check for an open or short circuit and clear any contamination that is present.
- Install a new paper Feed Sensor PWB, [PL 4.1 Item 15](#).

Check [CN15](#) (FFC) between the ADF Drive Motor and the Main PWB. **The circuit is good.**

Y N

- Check for an open or short circuit and clear any contamination that is present.
- Install a new ADF Module, [PL 1.1 Item 13](#).

Clear all jammed sheets from the paper path. If the fault persists, install a new Main PWB, [PL 1.1 Item 4](#).

## 05-500 DADF Jam RAP

BSD-ON:BSD 1

### Control Panel Fault Displayed

B205: Document Feeder Cover Open

B215: Jam in the Document Feeder

There is a jam in the document feeder or the document feeder top cover is not fully closed.

### Initial Actions

- Clear the jam in the Document Feeder.
- Close the Document Feeder top cover.

### Procedure

Check the circuit between the Top Cover Sensor, [PL 1.2 Item 4](#), and the Main PWB, [PL 1.1 Item 4](#). **The circuit is good.**

Y N

- Check check for and remove any contamination present.
- Check for broken or defective wires or cables, repair as necessary.

Install a new Main PWB, [PL 1.1](#).



## 05-920 DADF Top Cover Open RAP

BSD-ON: [BSD 2](#)

### Control Panel Fault Displayed

B205: NA

B215: Document Feeder Top Cover is Open

The Document Feeder or Document Feeder Top Cover is not securely latched.

### Initial Actions

- Close the Document Feeder unit.
- Close the Document Feeder top cover.

### Procedure

Check [CN15](#) (FFC) between the ADF Cover Sensor and the Main PWB. **The circuit is good.**

- |   |   |
|---|---|
| Y | N   |
|   | • The FFC is fully seated in the connector on the Main PWB and the ADF PWB. |
|   | • The FFC is not broken, worn, or damaged.                                  |
|   | • Install a new ADF Module, <a href="#">PL 1.1 Item 13</a> .                |

Install a new Main PWB, [PL 1.1 Item 4](#).

## 06-100 / 200 LSU Motor RAP

BSD-ON: [BSD 1](#)

### Control Panel Fault Displayed

**06-100** LSU Error: The machine has detected that the Laser Scanner Unit (LSU) Drive Motor is not working correctly.

B205: LSU Motor error

B215: Device Error

**06-200** LSU HSync Error: The machine has detected that the Laser Scanner Unit (LSU) Drive Motor is not working correctly.

B205: LSU Hsync Error

B215: Device Error

### WARNING

**Use eye protection when performing the following procedure. Failure to wear eye protection could result in serious personal injury.**

**DANGER: Porter des lunettes de sécurité pendant la procédure suivante. À défaut, de graves blessures peuvent se produire.**

**AVVERTENZA: Indossare occhiali di protezione durante la seguente procedura. In caso contrario, si possono provocare gravi ferite.**

**VORSICHT: Folgende Verfahren dürfen nicht ohne Schutzbrille angewandt werden. Die Nichteinhaltung dieser Regel kann zu ernsthaften körperlichen Verletzungen führen.**

**AVISO: Use gafas de protección para realizar el procedimiento siguiente. No proteger los ojos puede ocasionar daños personales graves.**

### WARNING

**Do not perform repair activities with the power on or electrical power supplied to the machine. The machine could activate and cause serious personal injury when the power is on or electrical power is supplied.**

**DANGER: Ne pas effectuer de dépannage avec le contact principal activé ou avec l'alimentation électrique appliquée à la machine: celle-ci pourrait démarrer et causer de graves blessures.**

**AVVERTENZA: Non effettuare alcuna riparazione con la macchina accesa o con l'alimentazione elettrica inserita. La macchina potrebbe avviarsi all'improvviso e causare gravi ferite.**

**VORSICHT: Es dürfen keine Reparaturarbeiten durchgeführt werden, solange das Gerät eingeschaltet oder mit der Stromquelle verbunden ist. Das Gerät kann u.U in den Aktiv-Zustand übergehen und somit erhebliche körperliche Schäden verursachen.**

**AVISO: No realice reparaciones con la máquina encendida o conectada a la corriente. La máquina podría activarse y ocasionar daños personales graves.**

### Procedure

Enter Diagnostic Mode, [GP 1](#), [[DC330](#), [[110](#)] **LSU Motor1 Ready**] to test the LSU motor. **The motor runs.**

- |   |  |
|---|--|
| Y | N  |
|   | Check the Flat Cable, <a href="#">PL 4.1 Item 1</a> , and connectors on the Laser Scanner Unit (LSU). <b>The connections are secure.</b> |

A

Y N

- Check the Flat Cable for excessive wear, breaks in the insulation cover, and no contamination present.
- Disconnect and securely reconnect the Flat Cable.

Check the Flat Cable for an open or short circuit. **The Flat Cable is good.**

Y N

Install a new Flat Cable, [PL 4.1 Item 1](#).

Install a new Laser Scanner Unit (LSU), [PL 4.1 Item 22](#).

Go to SCP 04 Final Actions.

## 07-110 Paper Tray 1 Empty RAP

BSD-ON:[BSD 1](#)

### Control Panel Fault Displayed

B205: Tray 1 Empty

B215: Tray 1 is Out of Paper

The Exit Sensor failed to detect paper in the tray.

### Initial Actions

Ensure that paper is loaded in the tray. Clear any jammed sheets. Refer to Section 11 in the WorkCentre B215/B205 User Guide for detailed instructions on clearing paper jams.

### WARNING

**Do not perform repair activities with the power on or electrical power supplied to the machine. The machine could activate and cause serious personal injury when the power is on or electrical power is supplied.**

**DANGER: Ne pas effectuer de dépannage avec le contact principal activé ou avec l'alimentation électrique appliquée à la machine: celle-ci pourrait démarrer et causer de graves blessures.**

**AVVERTENZA: Non effettuare alcuna riparazione con la macchina accesa o con l'alimentazione elettrica inserita. La macchina potrebbe avviarsi all'improvviso e causare gravi ferite.**

**VORSICHT: Es dürfen keine Reparaturarbeiten durchgeführt werden, solange das Gerät eingeschaltet oder mit der Stromquelle verbunden ist. Das Gerät kann u.U in den Aktiv-Zustand übergehen und somit erhebliche körperliche Schäden verursachen.**

**AVISO: No realice reparaciones con la máquina encendida o conectada a la corriente. La máquina podría activarse y ocasionar daños personales graves.**

### Procedure

Check the Exit Sensor Actuator, [PL 4.5 Item 5](#). **The actuator moves freely and is undamaged.**

Y N

Install a new Exit Sensor Actuator, [PL 4.5 Item 5](#).

Enter Diagnostic Mode, [GP 1](#), [[DC330](#), [\[102\]](#), [Tray 1 Empty](#)] to block and clear the Tray 1 Empty Sensor. **The sensor signal changes.**

Y N

Check for 3.3VDC on the Main PWB. **The voltage is present on the Main PWB.**

Y N

Check that all voltages are present between the HVPS PWB and the Main PWB. **The voltages between the HVPS PWB and the Main PWB are present**

Y N

- Install a new HVPS PWB, [PL 4.1 Item 2](#).
- Install a new Main PWB, [PL 1.1 Item 4](#).

Install a new Exit Sensor, [PL 4.5 Item 3](#).

A B

A B  
Install a new Exit Sensor, PL 4.5 Item 3.

If the problem is intermittent, check the circuit of the Exit Sensor.

## 07-130 Paper Jam in Tray 1 RAP

BSD-ON:BSD 1

### Control Panel Fault Displayed

B205: Paper Jam in Tray1

B215: Jam in Tray 1

A paper jam has occurred in Tray 1.

### Initial Actions

- Remove jammed paper from Tray 1 area. (Refer to Section 11 in the Xerox® B215/B205 User Guide for detailed instructions on jam clearance.)
- Clear the paper path of any debris or obstructions.
- Ensure the loaded paper is within machine specifications. Refer to Section 6 General Procedures for product specifications.

### WARNING

**Do not perform repair activities with the power on or electrical power supplied to the machine. The machine could activate and cause serious personal injury when the power is on or electrical power is supplied.**

**DANGER: Ne pas effectuer de dépannage avec le contact principal activé ou avec l'alimentation électrique appliquée à la machine: celle-ci pourrait démarrer et causer de graves blessures.**

**AVVERTENZA: Non effettuare alcuna riparazione con la macchina accesa o con l'alimentazione elettrica inserita. La macchina potrebbe avviarsi all'improvviso e causare gravi ferite.**

**VORSICHT: Es dürfen keine Reparaturarbeiten durchgeführt werden, solange das Gerät eingeschaltet oder mit der Stromquelle verbunden ist. Das Gerät kann u.U in den Aktiv-Zustand übergehen und somit erhebliche körperliche Schäden verursachen.**

**AVISO: No realice reparaciones con la máquina encendida o conectada a la corriente. La máquina podría activarse y ocasionar daños personales graves.**

### Procedure

Remove Tray 1 and ensure that guides are set correctly. **The paper is loaded correctly in the tray.**

Y N  
Align the paper in Tray 1 then reinsert the tray.

Check the position of the jammed sheet. **The lead edge reached the Retard Roll.**

Y N  
Enter Diagnostic Mode, GP 1, [Machine Test, Diagnostics Mode, DC330, [102] Feed Sens] to block and clear the Feed Sensor. **The sensor signal changes.**

Y N  
Check for 3.3VDC on the Feed Sensor PWB. **The voltage is present at the connector on the Feed Sensor PWB.**

Y N  
Check for 3.3VDC on the Main PWB. **The voltage is present on the Main PWB.**

A B C

Y N

Check that all voltages are present between the HVPS PWB and the Main PWB. **The voltages between the HVPS PWB and the Main PWB are present.**

Y N

- Install a new HVPS PWB, [PL 4.1 Item 2.](#)
- Install a new Main PWB, [PL 1.1 Item 4.](#)

Install a new Paper Feed Sensor PWB, [PL 4.4 Item 20.](#)

Install a new Paper Feed Sensor PWB, [PL 4.4 Item 20.](#)

Install a new Paper Feed Sensor PWB, [PL 4.4 Item 20.](#)

In Diagnostics Mode, go to **[101-Clutch, Tray 1 Pick up]** to energize the clutch. **The clutch engages.**

Y N

Check for 24VDC on the Paper Feed PWB. **The voltage is present at the connector on the Paper Feed PWB.**

Y N

Check that all voltages are present between the HVPS PWB and the Main PWB. **The voltages between the HVPS PWB and the Main PWB are present.**

Y N

- Install a new HVPS PWB, [PL 4.1 Item 2.](#)
- Install a new Main PWB, [PL 1.1 Item 4.](#)

Install a new Paper Feed PWB, [PL 4.1 Item 15.](#)

Install a new Feed Clutch, [PL 4.1 Item 5.](#)

Perform SCP Final Actions.

Remove any jammed paper. Check the following for wear or damage and replace as required:

- Retard Roll, [PL 4.5 Item 15.](#)
- Paper Feed Roll Assembly, [PL 4.5 Item 11.](#)
- Earth Transfer Plate, [PL 4.4 Item 1.](#)
- Earth Transfer Plate Springs, [PL 4.4 Item 3](#) and [PL 4.4 Item 7.](#)

## 07-500 Manual Feed Slot Paper Empty RAP

BSD-ON:[BSD 1](#)

### Control Panel Fault Displayed

B205: Bypass Empty

B215: Bypass Tray is Out of Paper

The Manual Feed Slot Empty Sensor failed to detect paper in the Manual Feed Slot.

### Initial Actions

Ensure that paper is loaded in the tray. Clear any jammed sheets. (Refer to Section 11 in the Xerox® B215/B205 User Guide for detailed instructions on jam clearance.)

### WARNING

**Do not perform repair activities with the power on or electrical power supplied to the machine. The machine could activate and cause serious personal injury when the power is on or electrical power is supplied.**

**DANGER: Ne pas effectuer de dépannage avec le contact principal activé ou avec l'alimentation électrique appliquée à la machine: celle-ci pourrait démarrer et causer de graves blessures.**

**AVVERTENZA: Non effettuare alcuna riparazione con la macchina accesa o con l'alimentazione elettrica inserita. La macchina potrebbe avviarsi all'improvviso e causare gravi ferite.**

**VORSICHT: Es dürfen keine Reparaturarbeiten durchgeführt werden, solange das Gerät eingeschalten oder mit der Stromquelle verbunden ist. Das Gerät kann u.U in den Aktiv-Zustand übergehen und somit erhebliche körperliche Schäden verursachen.**

**AVISO: No realice reparaciones con la máquina encendida o conectada a la corriente. La máquina podría activarse y ocasionar daños personales graves.**

### Procedure

Check the Registration Sensor actuator. **The actuator moves freely and is undamaged.**

Y N

Install a new Registration Sensor Actuator, [PL 4.4 Item 19.](#)

Enter Diagnostics Mode, Select **[Machine Test, Diagnostics Mode, DC330 Component Control, 102-Sensor, Registration Sensor]** to block and clear the Registration Sensor. **The sensor signal changes.**

Y N

Check for 3.3VDC on the Main PWB. **The voltage is present on the Main PWB.**

Y N

- Install a new HVPS PWB, [PL 4.1 Item 2.](#)
- Install a new Main PWB, [PL 1.1 Item 4.](#)

Install a new Paper Feed Sensor PWB, [PL PL 4.4 Item 20.](#)

Perform SCP Final Actions.

## 07-530 Paper Feed - Manual Feed Slot RAP

BSD-ON:BSD 1

### Control Panel Fault Displayed

B205: Jam in the Bypass

B215: Jam in the Bypass Tray

The lead edge was not detected by the Paper Feed Sensor.

### Initial Actions

Clear any jammed sheets. Refer to Section 11 in the Xerox® B215/B205 User Guide for detailed instructions on clearing paper jams.

### WARNING

**Do not perform repair activities with the power on or electrical power supplied to the machine. The machine could activate and cause serious personal injury when the power is on or electrical power is supplied.**

**DANGER: Ne pas effectuer de dépannage avec le contact principal activé ou avec l'alimentation électrique appliquée à la machine: celle-ci pourrait démarrer et causer de graves blessures.**

**AVVERTENZA: Non effettuare alcuna riparazione con la macchina accesa o con l'alimentazione elettrica inserita. La macchina potrebbe avviarsi all'improvviso e causare gravi ferite.**

**VORSICHT: Es dürfen keine Reparaturarbeiten durchgeführt werden, solange das Gerät eingeschaltet oder mit der Stromquelle verbunden ist. Das Gerät kann u.U in den Aktiv-Zustand übergehen und somit erhebliche körperliche Schäden verursachen.**

**AVISO: No realice reparaciones con la máquina encendida o conectada a la corriente. La máquina podría activarse y ocasionar daños personales graves.**

### Procedure

Check the position of the jammed sheet. **The lead edge reached the Retard Roll.**

**Y N**  
Enter Diagnostic Mode, GP 1, [**Machine Test, Diagnostics Mode, DC330 Component Control, 102-Sensor, Feed Sens**] to block and clear the Feed Sensor. **The sensor signal changes.**

- Y N**
1. Check for an open or short circuit.
  2. Install a new Paper Feed Sensor PWB, [PL 4.4 Item 20](#).

In Diagnostics Mode, select: [**101-Clutch, Tray 1 Pick up (Feed)**] to engage the drive to pick up paper from tray 1. **The clutch engages.**

- Y N**
1. Check for an open or short circuit.
  2. Install a new Feed Clutch, [PL 4.1 Item 5](#).

Perform SCP Final Actions.

Check the Paper Feed Sensor Actuator. **The actuator moves freely is and undamaged.**

**Y N**  
Install a new Paper Feed Actuator, [PL 4.4 Item 18](#).

Inspect the Paper Feed Sensor for damage. **The sensor is OK.**

- Y N**
1. Check for an open or short circuit.
  2. Install a new Paper Feed Sensor PWB, [PL 4.4 Item 20](#).

Check the circuit of the Paper Feed Sensor.

## 07-600 Paper Tray Empty RAP

BSD-ON:BSD 1

### Control Panel Fault Displayed

B205: All trays empty

B215: The Device is Out of Paper

The Tray 1 Empty sensor and the Registration sensor failed to detect paper in the paper trays.

### Initial Actions

Ensure that paper is loaded in the trays. Clear any jammed sheets. (Refer to Section 11 in the Xerox® B215/B205 User Guide for detailed instructions on jam clearance.)

### WARNING

**Do not perform repair activities with the power on or electrical power supplied to the machine. The machine could activate and cause serious personal injury when the power is on or electrical power is supplied.**

**DANGER: Ne pas effectuer de dépannage avec le contact principal activé ou avec l'alimentation électrique appliquée à la machine: celle-ci pourrait démarrer et causer de graves blessures.**

**AVVERTENZA: Non effettuare alcuna riparazione con la macchina accesa o con l'alimentazione elettrica inserita. La macchina potrebbe avviarsi all'improvviso e causare gravi ferite.**

**VORSICHT: Es dürfen keine Reparaturarbeiten durchgeführt werden, solange das Gerät eingeschaltet oder mit der Stromquelle verbunden ist. Das Gerät kann u.U in den Aktiv-Zustand übergehen und somit erhebliche körperliche Schäden verursachen.**

**AVISO: No realice reparaciones con la máquina encendida o conectada a la corriente. La máquina podría activarse y ocasionar daños personales graves.**

### Procedure

Check the Exit Sensor, [PL 4.5 Item 3](#), and the Paper Feed Sensor PWB, [PL 4.4 Item 20](#), for contamination. **The sensors are free of contamination.**

**Y N**  
| Clean the sensors.

Refer to the following RAPs:

- [07-500 Manual Feed Slot Paper Empty Fault RAP](#)
- [07-110 Paper Tray 1 Empty Fault RAP](#)

## 08-100 Paper Feed - Tray 1 RAP

BSD-ON:BSD 1

### Control Panel Fault Displayed

B205: Jam inside machine

B215: Jam in the Device

The lead edge was not detected by the Paper Feed Sensor.

### Initial Actions

Clear any jammed sheets. (Refer to Section 11 in the Xerox® B215/B205 User Guide for detailed instructions on jam clearance.)

### WARNING

**Do not perform repair activities with the power on or electrical power supplied to the machine. The machine could activate and cause serious personal injury when the power is on or electrical power is supplied.**

**DANGER: Ne pas effectuer de dépannage avec le contact principal activé ou avec l'alimentation électrique appliquée à la machine: celle-ci pourrait démarrer et causer de graves blessures.**

**AVVERTENZA: Non effettuare alcuna riparazione con la macchina accesa o con l'alimentazione elettrica inserita. La macchina potrebbe avviarsi all'improvviso e causare gravi ferite.**

**VORSICHT: Es dürfen keine Reparaturarbeiten durchgeführt werden, solange das Gerät eingeschaltet oder mit der Stromquelle verbunden ist. Das Gerät kann u.U in den Aktiv-Zustand übergehen und somit erhebliche körperliche Schäden verursachen.**

**AVISO: No realice reparaciones con la máquina encendida o conectada a la corriente. La máquina podría activarse y ocasionar daños personales graves.**

### Procedure

Check the Tray 1 Paper Feed Sensor Actuator. **The Actuator moves freely.**

**Y N**  
| Install a new Feed Sensor Actuator, [PL 4.4 Item 18](#).

Check the position of the jammed sheet. **The lead edge reached the Retard Roll.**

**Y N**  
| Enter Diagnostic Mode, GP 1, [**Machine Test, Diagnostics Mode, DC330 Component Control, 101-Clutch, Tray 1 Pick up**] to engage the drive to pick up paper from tray 1 **The clutch engages.**

- Y N**
1. Check the circuit between the Feed Clutch and the HVPS PWB for an open or short circuit.
  2. Install a new Feed Clutch, [PL 4.1 Item 4](#).

Check the Feed Sensor Actuator, [PL 4.4 Item 18](#). **The actuator moves freely.**

**Y N**  
| Install a new Feed Sensor Actuator, [PL 4.4 Item 18](#).

A B

In Diagnostics Mode. Select: **[102-Sensor, Feed Sens]** to block and clear the Paper Feed Sensor. **The signal changes.**

Y N

1. Verify no contamination present in the Paper Feed Sensor PWB, [PL 4.4 Item 20](#).
2. Check the Paper Feed Sensor harness for damage or excessive wear, open, or short circuit.
3. Install a new Paper Feed Sensor PWB, [PL 4.4 Item 20](#).

Perform SCP Final Actions.

Check the Paper Feed Sensor harness for damage or excessive wear, open, or short circuit.

## 08-500 Paper Jam in Exit Area RAP

BSD-ON:[BSD 1](#)

### Control Panel Fault Displayed

B205: Wrap Jam Call for Service

B215: Jam in the Device

The machine has detected a paper jam in the Exit Area.

### Initial Actions

Open the Rear Cover and remove jammed sheets from exit area. Refer to Section 11 in the Xerox® B215/B205 User Guide for detailed instructions on clearing paper jams.

Check the Paper Guides for proper positioning.

Check the Duplex Gate, [PL 2.1 Item 7](#), and Spring, [PL 2.1 Item 8](#), for damage. Ensure that the Duplex Gate is seated correctly and moves freely without binding.

### Procedure

Enter Diagnostic Mode, [GP 1](#), **[DC330, [102] Feed Sens]** to block and clear the Exit Sensor. **The Exit Sensor is OK.**

Y N

1. Check that there is no contamination present.
2. Check for an open or short circuit.
3. Install a new Exit Sensor, [PL 4.1 Item 24](#).

In Diagnostics Mode. Select **[102-Sensor, Registration]** to block and clear the Registration Sensor. **The signal changes.**

Y N

1. Check that there is no contamination present.
2. Check for an open or short circuit.
3. Install a new Paper Feed Sensor PWB, [PL 4.4 Item 20](#).

Inspect the Exit Roller and Drives for wear or damage, [PL 4.3](#). Install new components as required.

## 08-600 Paper Jam in Duplex Area RAP

BSD-ON: [BSD 1](#)

### Control Panel Fault Displayed

B205: Jam at duplex path

B215: Jam in the Device

The machine has detected a paper jam in the Duplex Area.

### Initial Actions

Remove jammed sheets from duplex area. Refer to Section 11 in the Xerox® B215/B205 User Guide for detailed instructions on clearing paper jams.

Ensure that the paper guide and machine settings are correct for the paper that is loaded in the tray.

### Procedure

Check the Exit Sensor Actuator. **The actuator moves freely.**

**Y N**  
| Install a new Exit Sensor Actuator.

Enter Diagnostic Mode, [GP 1](#), [[DC330](#), [[102](#)] [Out-Bin Full Sensor](#)] to block and clear the Exit Sensor. **The sensor is OK.**

**Y N**  
|  
| 1. Check that there is no contamination present.  
| 2. Check for an open or short circuit.  
| 3. Install a new Exit Sensor, [PL 4.1 Item 24](#).

Check the following parts for wear or damage and replace if needed:

- Duplex Paper Guide, [PL 4.2 Item 6](#).
- Duplex Gate, [PL 2.1 Item 7](#).
- Duplex Gate Spring, [PL 2.1 Item 8](#).
- Exit Paper Guide, [PL 2.1 Item 6](#).

Verify the Duplex Gate is seated correctly and moves freely without binding.

## 08-700 Output Bin Full Fault

BSD-ON: [BSD 1](#)

### Control Panel Fault Displayed

B205: Output Bin Full. Remove Paper

B215: Output Bin Full. Remove Paper

The Output Tray Full Sensor has detected that the Output Tray is full.

### Initial Actions

Remove sheets from the Output Tray. (Maximum capacity is 150 sheets/ standard paper 8.5 x 11 in./ 80g/m2.)

### Procedure

Enter Diagnostics Mode. Select: [[Machine Test](#), [EDC Mode](#), [DC330 Component Control](#), [102-Sensor](#), [Out Bin Full](#)] to test the Out Bin Full Sensor. **The signal changes.**

**Y N**  
|  
| • Check the sensor connector is fully seated.  
| • Check for and remove any contamination present.  
| • Check for an open or short circuit.  
| • Install a new Output Tray Full Sensor, [PL 4.3 Item 1](#).

Check the Bin Full Sensor Actuator, [PL 2.2 Item 7](#), for binding or any debris causing the actuator to respond intermittently or fail to actuate the Output Tray Full Sensor. Clean the Bin Full Sensor Actuator and surrounding area to full operation.



## 09-100 Toner Cartridge Near End of Life RAP

### Control Panel Fault Displayed

B205: Toner is low. Order Print Cart.

B215: Toner is Low

The toner cartridge life is less than 10%.

### Procedure

1. Press the Information button on the Control Panel, then select the menu items listed below to print the **Supplies Information Report**. Refer to the Xerox® B215/B205 User Guide for detailed instructions on Menu Options using the Control Panel.
  - WorkCentre B205: **[Info Pages, Supplies Info]**.
  - WorkCentre B215: **[Machine Status, Info Pages, Supplies Info]**.
2. Check the remaining life of the Print Cartridge.
3. If the Toner Cartridge has reached end of life, switch Off the power and Install a new Print Cartridge.

## 09-200 Toner Cartridge Empty RAP

### Control Panel Fault Displayed

B205: Please check the printer and add toner.

B215: Out of Toner

The Toner Cartridge has reached end of life.

### WARNING

**Do not perform repair activities with the power on or electrical power supplied to the machine. The machine could activate and cause serious personal injury when the power is on or electrical power is supplied.**

**DANGER: Ne pas effectuer de dépannage avec le contact principal activé ou avec l'alimentation électrique appliquée à la machine: celle-ci pourrait démarrer et causer de graves blessures.**

**AVVERTENZA: Non effettuare alcuna riparazione con la macchina accesa o con l'alimentazione elettrica inserita. La macchina potrebbe avviarsi all'improvviso e causare gravi ferite.**

**VORSICHT: Es dürfen keine Reparaturarbeiten durchgeführt werden, solange das Gerät eingeschaltet oder mit der Stromquelle verbunden ist. Das Gerät kann u.U in den Aktiv-Zustand übergehen und somit erhebliche körperliche Schäden verursachen.**

**AVISO: No realice reparaciones con la máquina encendida o conectada a la corriente. La máquina podría activarse y ocasionar daños personales graves.**

### Procedure

1. Press the Information button on the Control Panel, then select the menu items listed below to print the **Supplies Information Report**. Refer to the Xerox® B215/B205 User Guide for detailed instructions on Menu Options using the Control Panel.
  - WorkCentre B205: **[Info Pages, Supplies Info]**.
  - WorkCentre B215: **[Machine Status, Info Pages, Supplies Info]**.
2. Check the remaining life of the Toner Cartridge.
3. If the Toner Cartridge is at end of life, switch Off the power and Install a new Print Cartridge.

## 09-300 Imaging Unit Near End of Life RAP

### Control Panel Fault Displayed

B205: Drum is low. Order Drum Cart.

B215: Drum Cartridge is Near End of Life

The Imaging Cartridge life is less than 10%.

### Procedure

1. Press the Information button on the Control Panel, then select the menu items listed below to print the **Supplies Information Report**. Refer to the Xerox® B215/B205 User Guide for detailed instructions on Menu Options using the Control Panel.
  - WorkCentre B205: **[Info Pages, Supplies Info]**.
  - WorkCentre B215: **[Machine Status, Info Pages, Supplies Info]**.
2. Check the remaining life of the Imaging Unit.
3. If the Imaging Unit has reached end of life, switch off the power, then install a new Imaging Unit.

## 09-400 Imaging Unit End of Life RAP

### Control Panel Fault Displayed

B205: Replace Drum Cart.

B215: Replace the Drum Cartridge

The Imaging Unit has reached end of life.

### Procedure

1. Press the Information button on the Control Panel, then select the menu items listed below to print the **Supplies Information Report**. Refer to the Xerox® B215/B205 User Guide for detailed instructions on Menu Options using the Control Panel.
  - WorkCentre B205: **[Info Pages, Supplies Info]**.
  - WorkCentre B215: **[Machine Status, Info Pages, Supplies Info]**.
2. Check the remaining life of the Imaging Unit.
3. If the Imaging Unit is at end of life, switch off the machine, then install a new Imaging Unit.

## 09-500 Toner Cartridge Not Installed RAP

### Control Panel Fault Displayed

B205: Install Toner

B215: Check Toner Cartridge Position

The Print cartridge has not been installed or machine software is unable to detect the Print Cartridge.

### Initial Actions

Ensure that the Print Cartridge has been installed and the cover is fully closed and latched.

### Procedure

1. Switch off, then switch on the machine
2. Remove the Print cartridge. Rotate the cartridge five to six completions to distribute the toner evenly.
3. Check the CRUM contact area for contamination and clean if necessary.
4. Reinstall the Print Cartridge.
5. If the problem continues, install a new Print Cartridge.

## 09-600, 09-900 Imaging Unit Not Installed or Invalid RAP

BSD-ON: [BSD 1](#)

### Control Panel Fault Displayed

**09-600** The imaging unit has not been installed.

B205: Install Drum Cartridge

B215: Drum Cartridge is not installed. Install the unit.

**09-900** The machine firmware has determined the imaging unit is invalid.

B205: Invalid Drum Cart.

B215: Incompatible Toner Cartridge has been Detected

### WARNING

**Do not perform repair activities with the power on or electrical power supplied to the machine. The machine could activate and cause serious personal injury when the power is on or electrical power is supplied.**

**DANGER: Ne pas effectuer de dépannage avec le contact principal activé ou avec l'alimentation électrique appliquée à la machine: celle-ci pourrait démarrer et causer de graves blessures.**

**AVVERTENZA: Non effettuare alcuna riparazione con la macchina accesa o con l'alimentazione elettrica inserita. La macchina potrebbe avviarsi all'improvviso e causare gravi ferite.**

**VORSICHT: Es dürfen keine Reparaturarbeiten durchgeführt werden, solange das Gerät eingeschalten oder mit der Stromquelle verbunden ist. Das Gerät kann u.U in den Aktiv-Zustand übergehen und somit erhebliche körperliche Schäden verursachen.**

**AVISO: No realice reparaciones con la máquina encendida o conectada a la corriente. La máquina podría activarse y ocasionar daños personales graves.**

### Procedure

Verify the Drum Cartridge is a Genuine Xerox® drum cartridge.

1. Press the Information button on the Control Panel, then select the menu items listed below to print the **Supplies Information Report**.
  - WorkCentre B205: [**Info Pages, Supplies Info**].
  - WorkCentre B215: [**Machine Status, Info Pages, Supplies Info**].
2. Check the Imaging Unit information.

**The Imaging Unit is compatible with the printer.**

**Y N**

Install a new Drum Cartridge if it is not a genuine Xerox® cartridge.

Verify the Drum Cartridge CRUM is fully seated. **The Imaging Unit connection is OK.**

**Y N**

- Check that there is no contamination present.
- Check for an open or short circuit.
- Firmly seat the Drum Cartridge.

Check the circuit of the Drum Cartridge.

## 09-800 Incompatible Toner Cartridge RAP

### Control Panel Fault Displayed

B205: Invalid Print Cart.

B215: Incompatible Toner Cartridge has been Detected

The Toner Cartridge is not compatible with the printer.

### Procedure

1. Press the Information button on the Control Panel, then select the menu items listed below to print the **Supplies Information Report**.
  - WorkCentre B205: [Info Pages, Supplies Info].
  - WorkCentre B215: [Machine Status, Info Pages, Supplies Info].
2. Check the toner cartridge information. Install a new Toner Cartridge if is not a genuine Xerox® cartridge.

## 10-100 Fuser Temperature (Open) RAP

BSD-ON: [BSD 1](#)

### Control Panel Fault Displayed

B205: Open Fuser error

B215: Fuser Error

During operation, the temperature of the Fuser temperature does not increase.

### WARNING

**Do not handle the fuser components until they have cooled. Some fuser components operate at hot temperatures and can produce serious personal injury if touched.**

**DANGER: Ne pas manipuler les éléments du four avant de les laisser refroidir. Certains éléments du four fonctionnent à des températures très élevées et peuvent causer de graves blessures s'ils sont touchés.**

**AVVERTENZA: Non maneggiare i componenti del fusore finché non sono raffreddati. Alcuni di questi componenti funzionano ad alte temperature e possono provocare gravi ferite se vengono toccati.**

**VORSICHT: Die Fixieranlage sollte erst gehandhabt werden, wenn diese genügend abgekühlt ist. Einige Teile der Fixieranlage erzeugen übermäßige Hitze und führen bei der Berührung zu schweren Verbrennungen.**

**AVISO: No manipule los componentes del fusor antes de que se enfríen. Algunos de los componentes del fusor funcionan a altas temperaturas y pueden ocasionar daños personales graves si se los toca.**

### WARNING

**Do not perform repair activities with the power on or electrical power supplied to the machine. The machine could activate and cause serious personal injury when the power is on or electrical power is supplied.**

**DANGER: Ne pas effectuer de dépannage avec le contact principal activé ou avec l'alimentation électrique appliquée à la machine: celle-ci pourrait démarrer et causer de graves blessures.**

**AVVERTENZA: Non effettuare alcuna riparazione con la macchina accesa o con l'alimentazione elettrica inserita. La macchina potrebbe avviarsi all'improvviso e causare gravi ferite.**

**VORSICHT: Es dürfen keine Reparaturarbeiten durchgeführt werden, solange das Gerät eingeschaltet oder mit der Stromquelle verbunden ist. Das Gerät kann u.U in den Aktiv-Zustand übergehen und somit erhebliche körperliche Schäden verursachen.**

**AVISO: No realice reparaciones con la máquina encendida o conectada a la corriente. La máquina podría activarse y ocasionar daños personales graves.**

### Procedure

Switch off the machine, then verify the Fuser connection is fully seated. **The Fuser connections are OK.**

**Y N**  
Firmly reconnect the Fuser assembly, then switch on the machine.

Check for +3.3 VDC to the Thermistor on the Main PWB. **The voltage is present.**

Y N

- Check the wire harness for open or short circuits.
- Install a new Main PWB, [PL 1.1 Item 4](#).

Check the voltage to the Over Heat Thermostat. **The voltage is present.**

Y N

- Verify the input AC line voltage to the LVPS PWB is correct, refer to, [BSD 1](#).
- Check the Over Heat Thermostat for contamination.
- Check the wire harness for open or short circuits.
- Install a new:
  1. LVPS, [PL 4.1 Item 3](#).
  2. HVPS, [PL 4.1 Item 2](#).

If the fault persists, install a new Fuser Module, [PL 5.1 Item 26](#).

## 10-200, 10-300 Fuser Temperature Error RAP

BSD-ON:[BSD 1](#)

### Control Panel Fault Displayed

**10-200** The temperature of the Fuser did not reach normal operating range of 383°F ± 5°F (195°C ± 5°C).

B205: Low Heat error

B215: Fuser Error

**10-300** The temperature of the Fuser exceeds normal operating range of 383°F ± 5°F (195°C ± 5°C).

B205: Over Heat error

B215: Fuser Error

### WARNING

**Do not perform repair activities with the power on or electrical power supplied to the machine. The machine could activate and cause serious personal injury when the power is on or electrical power is supplied.**

**DANGER: Ne pas effectuer de dépannage avec le contact principal activé ou avec l'alimentation électrique appliquée à la machine: celle-ci pourrait démarrer et causer de graves blessures.**

**AVVERTENZA: Non effettuare alcuna riparazione con la macchina accesa o con l'alimentazione elettrica inserita. La macchina potrebbe avviarsi all'improvviso e causare gravi ferite.**

**VORSICHT: Es dürfen keine Reparaturarbeiten durchgeführt werden, solange das Gerät eingeschalten oder mit der Stromquelle verbunden ist. Das Gerät kann u.U in den Aktiv-Zustand übergehen und somit erhebliche körperliche Schäden verursachen.**

**AVISO: No realice reparaciones con la máquina encendida o conectada a la corriente. La máquina podría activarse y ocasionar daños personales graves.**

### Procedure

Enter Diagnostic Mode, [GP 1](#), [[DC330](#), [\[109\] Fuser Temperature A](#)] to obtain a temperature reading from the Fuser. **The Fuser temperature is within normal operating range.**

Y N

- Install a new Fuser Module, [PL 5.1 Item 26](#).

If problem is intermittent, check the Fuser Module connector is not cracked, broken, or other damage. Repair or replace as required.

## 15-100, 15-110 Scan to E-mail RAP

### Control Panel Fault Displayed

**15-100** No Email address assigned to group name.

B205: Group Not Available

B215: No Email Address for Group Name

**15-110** Email SMTP server returned an error during transmission.

B205: Email Send Error

B215: Email Send Error

Faults displayed when the device encounters scan to e-mail problems. The faults are listed in code order, together with any recommended action. Please note that service actions are limited.

### Procedure

#### 15-100 Group Name has no Assigned Email Address

No email address is assigned to the group name.

- Remove the group name from the 'To:' field or enter a valid email address.

#### 15-110 Email Send Failed

The email SMTP server returned an error during transmission. The SMTP server authentication may be supported but not enabled on the device.

- Verify SMTP authentication is enabled on the machine.
- Resend the email.

## 15-130, 15-340 Mail Too Large RAP

### Control Panel Fault Displayed

**15-130** This error is raised when the MFP is unable to split the mail and send it.

B205: NA

B215: Mail Size Limit has been Exceeded

**15-340** Maximum mail size configured exceeds the server limit.

B205: Mail Exceeds Server Support

B215: Maximum Mail Size has been Exceeded

The mail size has exceeded the server support.

### Initial Actions

- Reduce max mail size option.
- Increase mail size on this device via CentreWare Internet Services

### Procedure

If problem persists, increase mail size allotment on mail server.

## 15-140 / 150 Invalid Email / Group Address RAP

### Control Panel Fault Displayed

**15-140** This message will be displayed when we enter an email id.

B205: NA

B215: Invalid Email Address

**15-150** This message will be displayed when we try to enter an invalid GROUP number.

B205: Group Not Available

B215: Group Name is not Available

An invalid email address or group has been entered.

### Procedure

Enter valid email address. If problem persists, contact email administrator.

## 15-300 Network Connection Failure RAP

### Control Panel Fault Displayed

B205: Connection Error

B215: Network Connection Error

Any kind of communication or network failure during SMTP or LDAP operations.

### Procedure

- Switch off, then switch on the machine.
- Check the physical connections to the customer's network. If connected through Ethernet; check the cable is connected to the correct customer network jack, is fully seated and locked in the machine Ethernet port and the customer Ethernet port.
- Visually check the Ethernet port on the machine for network activity.
- If the fault persists, request the customer to verify the network settings for connection to the customer network are correct, then verify the customer network settings are correct in the machine settings.

## 15-310 / 600 Authentication Failure RAP

### Control Panel Fault Displayed

**15-310** Whenever NIC return authentication failure for Invalid Account or Password entered by the user.

B205: Send Error (AUTH)

B215: Authentication Error

**15-600** In case Authentication is disable in MFP and the mail server requires it.

B205: Send Error (AUTH)

B215: Authentication is Required

The user has entered an invalid account or password causing an authentication failure.

### Procedure

1. Verify account and network configuration.
2. Enter valid user credentials.

## 15-320 / 330 Mail Server Connection Failure RAP

### Control Panel Fault Displayed

**15-320** Can not contact SMTP server

B205: Connection Error

B215: Mail Server Connection Error

**15-330** Can not contact DNS server to resolve SMTP host name

B205: Send Error (DNS)

B215: DSN Connection Error

### Initial Actions

1. Check the SMTP IP address or host name.
2. Check the network configuration.

### Procedure

Check that the DNS server is online.



## 15-400 LDAP Communication Failure RAP

BSD-ON: [BSD 1](#)

### Control Panel Fault Displayed

B205: NA

B215: LDAP Communication Error

The machine is unable to contact the LDAP server.

### WARNING

**Do not perform repair activities with the power on or electrical power supplied to the machine. The machine could activate and cause serious personal injury when the power is on or electrical power is supplied.**

**DANGER: Ne pas effectuer de dépannage avec le contact principal activé ou avec l'alimentation électrique appliquée à la machine: celle-ci pourrait démarrer et causer de graves blessures.**

**AVVERTENZA: Non effettuare alcuna riparazione con la macchina accesa o con l'alimentazione elettrica inserita. La macchina potrebbe avviarsi all'improvviso e causare gravi ferite.**

**VORSICHT: Es dürfen keine Reparaturarbeiten durchgeführt werden, solange das Gerät eingeschaltet oder mit der Stromquelle verbunden ist. Das Gerät kann u.U in den Aktiv-Zustand übergehen und somit erhebliche körperliche Schäden verursachen.**

**AVISO: No realice reparaciones con la máquina encendida o conectada a la corriente. La máquina podría activarse y ocasionar daños personales graves.**

### Procedure

Printers using ethernet connection: **The ethernet connection is good.**

**Y N**

Connect the printer to the ethernet port connection.

Verify the ethernet connection is active and network services; Internet and other network services or devices are working.

Printers using WiFi: check the CN1 connector between the WiFi PWB, [PL 1.1 Item 10](#), and the Main PWB, [PL 1.1 Item 4](#). **The connector is fully seated.**

**Y N**

- Check for contamination or obstruction in the connector.
- Disconnect, then reconnect the connector.
- If the fault persist, install a new WiFi PWB, [PL 1.1 Item 10](#).

Perform the following checks:

- Check the LDAP IP address or Host Name.
- Check the LDAP port is open and connected.

## 15-410, 15-420 LDAP Search Failure RAP

### Control Panel Fault Displayed

**15-410** LDAP server returned an error during transmission.

B205: NA

B215: LDAP Search Error

**15-420** Displays when LDAP search timeout has exceeded parameter.

B205: NA

B215: LDAP Time Limit has been Exceeded

The LDAP server returned an error during transmission.

### Initial Actions

- Ensure that the LDAP server is enabled on the device and that maximum search results have not been exceeded.
- Check if the LDAP search has exceeded time limit parameters.

### Procedure

Resubmit the job. If problem persists, contact Email administrator.

## 15-510 Scan Error RAP

BSD-ON: [BSD 2](#)

### Control Panel Fault Displayed

B205: NA

B215: Scanner Error

Error at the Scanner Unit (Document jam etc).

### WARNING

**Do not perform repair activities with the power on or electrical power supplied to the machine. The machine could activate and cause serious personal injury when the power is on or electrical power is supplied.**

**DANGER: Ne pas effectuer de dépannage avec le contact principal activé ou avec l'alimentation électrique appliquée à la machine: celle-ci pourrait démarrer et causer de graves blessures.**

**AVVERTENZA: Non effettuare alcuna riparazione con la macchina accesa o con l'alimentazione elettrica inserita. La macchina potrebbe avviarsi all'improvviso e causare gravi ferite.**

**VORSICHT: Es dürfen keine Reparaturarbeiten durchgeführt werden, solange das Gerät eingeschaltet oder mit der Stromquelle verbunden ist. Das Gerät kann u.U in den Aktiv-Zustand übergehen und somit erhebliche körperliche Schäden verursachen.**

**AVISO: No realice reparaciones con la máquina encendida o conectada a la corriente. La máquina podría activarse y ocasionar daños personales graves.**

### Procedure

- Switch off, then switch on the machine.
- Check the scanner for any physical anomalies or interferences.
- Check the connection between the Main PWB and [CN11](#) (B205) or [CN18](#) (B215).

## 15-700 DNS Error RAP

### Control Panel Fault Displayed

B205: Send Error (DNS)

B215: DNS Error

A DNS resolution failure or the DNS server is not reachable.

### Initial Actions

- Check DNS server configuration.
- Check network configuration.

### Procedure

Ensure that the DNS server is online.

## 17-100 IP Conflict Error RAP

### Control Panel Fault Displayed

B205: Network Problem: IP Conflict

B215: IP Address Conflict Error

The IP address conflicts with that of another system causing a machine communication error.

### Procedure

Use Xerox Easy Print Manger to obtain a new IP address.

From the menu, select: [**Machine Settings, Network Settings, Assign IP address**].

## 17-110, 17-130, 17-140, 17-150, 17-200, 17-510, 17-600, 17-610 Network Controller RAP

### Control Panel Fault Displayed

**17-110** Connection error

B205: Connection error

B215: Server Connection has Failed

**17-130** Login error

B205: Login error

B215: Incorrect Login Information

**17-140** Access denied

B205: Access denied

B215: File Access is Denied

**17-150** Lock is exist

B205: Lock is exist

B215: LCK Folder Already Exists

**17-200** Network cable is disconnected

B205: Network Problem: Disconnect

B215: Network Connection Error

**17-510** Operation error

B205: Operation error

B215: Server Connection has Failed

**17-600** Filename is too long

B205: Filename is too long

B215: File Access has been Denied

**17-610** Scan file is exist

B205: Scan file is exist

B215: Duplicate Filename Exists

These faults display when the device encounters network controller problems. The faults are listed in code order together with recommended actions. Please note that the service actions are limited.

### Procedure

Go to the relevant fault code, then perform any service actions.

#### 17-110 Connection Error

The machine encountered an error when establishing a connection to the designated server.

- Request the customer verify connectivity and network setup settings are correct for the customer network.

### 17-130 Login Error

The machine can not login to the designated server.

- Request the customer verify connectivity and network setup settings are correct for the customer network.

### 17-140 Access Denied

A permissions error occurred.

- Request the customer verify the user has correct permissions to perform the task requested of the machine.

### 17-150 Lock Exists

- The \*.lck directory already exists.

### 17-200 Network Cable is Disconnected

- Ensure the network cable is connected.

### 17-510 Operation Error

An error occurred when sending the image file.

- Request the customer verify the image file is of the correct file type for the requested task.
- If the image file is on a USB drive, remove then reinsert the USB drive into the machine, then run the send job again.
- If the fault persists, request the customer change USB drives to a known good USB drive, then run the send job again.

### 17-600 Filename is Too Long

The name of the file to be sent is longer than the destination systems limits.

- Shorten the file name.

### 17-610 Scan File Exists

The file name already exists on the destination server.

- Change the file name.

## 17-310 Communication Error (Main PWB to Wireless PWB) RAP

**BSD-ON:** [BSD 1](#)

### Control Panel Fault Displayed

B205: Network Problem: Wi-Fi Connection

B215: Network Communication Error

The machine software has detected a communication error between the Main PWB and the Wireless PWB.

### Initial Actions

- Switch off, then switch on the machine
- Check machine network and data configuration settings.

### WARNING

**Do not perform repair activities with the power on or electrical power supplied to the machine. The machine could activate and cause serious personal injury when the power is on or electrical power is supplied.**

**DANGER: Ne pas effectuer de dépannage avec le contact principal activé ou avec l'alimentation électrique appliquée à la machine: celle-ci pourrait démarrer et causer de graves blessures.**

**AVVERTENZA: Non effettuare alcuna riparazione con la macchina accesa o con l'alimentazione elettrica inserita. La macchina potrebbe avviarsi all'improvviso e causare gravi ferite.**

**VORSICHT: Es dürfen keine Reparaturarbeiten durchgeführt werden, solange das Gerät eingeschaltet oder mit der Stromquelle verbunden ist. Das Gerät kann u.U in den Aktiv-Zustand übergehen und somit erhebliche körperliche Schäden verursachen.**

**AVISO: No realice reparaciones con la máquina encendida o conectada a la corriente. La máquina podría activarse y ocasionar daños personales graves.**

### Procedure

1. Ensure that the connectors are fully seated between the Main PWB and the Wireless PWB, [CN1](#).
2. If the fault persists, install new components in the following order:
  - Flat Cable, [PL 4.1 Item 1](#).
  - WiFi PWB, [PL 1.1 Item 10](#).
  - Main PWB, [PL 1.1 Item 4](#).

## 17-562 Auto-Registration Process Fails to Communicate Error RAP

### Control Panel Fault Displayed

B205: Smart eSolution: Reg error

B215: Auto-Registration Error

The auto-registration process failed to communicate.

### Procedure

Perform the steps that follow:

1. Ensure that the Xerox SMart eSolutions settings are correct.
2. Check the network cable and connection.
3. Check that the machine IP address is correct.

## 17-563 Machine Fails to Communicate with Xerox Edge Server Error RAP

### Control Panel Fault Displayed

B205: Smart eSolution: Comm error

B215: Edge Server Communication Error

The machine failed to communicate with the Xerox Edge Server.

### Procedure

Perform the steps that follow:

1. Ensure that the Xerox SMart eSolutions settings are correct.
2. Check the network cable and connection.
3. Check that the machine IP address is correct.
4. Check the SMart eSolutions edge host is connected and operational.

## 17-700 / 710 BOOTP Error RAP

### Control Panel Fault Displayed

#### 17-700 BOOTP Server Error

B205: BOOTP problem Auto IP Run

B215: BOOTP Server Error

#### 17-710 BOOTP Server Error

B205: BOOTP problem

B215: BOOTP Server Error

The machine displays the error message “DHCP, or BOOTP, causing a machine communication error.

### Procedure

1. Switch off, then switch on the machine
2. Check BOOTP and network configuration.

## 17-800 / 810 DHCP Error RAP

### Control Panel Fault Displayed

#### 17-800 DHCP Server Error

B205: DHCP problem: Auto IP Run

B215: DHCP Server Error

#### 17-810 DHCP Server Error

B205: DHCP problem

B215: DHCP Server Error

The machine displays the error message “DHCP, or BOOTP, causing a machine communication error.

### Procedure

1. Switch off, then switch on the machine
2. Check DHCP and network configuration.

## 17-900 802.1X Network Authentication Error RAP

### Control Panel Fault Displayed

B205: 802.1x Network Error

B215: 802.1X Authentication Error

The the 802.1X network authentication failed.

### Procedure

Ensure that the 802.1X EAP Type, User name, and Password, for the Machine, Authentication Switch and Authentication Server match.

## 17-910 Firmware Upgrade RAP

### Control Panel Fault Displayed

B205: Upgrade Error Reset Printer

B215: Firmware Upgrade Error

The firmware upgrade aborted due to an invalid file.

### Initial Actions

- Verify the firmware file is correct and the latest version, refer to [GP 3](#), Machine Firmware Version.

### Procedure

1. Switch off, then switch on the machine.
2. Perform Firmware Upgrade, [GP 7](#).
3. If the fault persists, perform the **[Machine Data, Clear All Memory]** procedure in Diagnostics Mode, [GP 1](#), then perform Firmware Upgrade, [GP 7](#).

## 20-100 Fax Communication Error RAP

BSD-ON: [BSD 2](#)

### Control Panel Fault Displayed

B205: COMM. Error

B215: Communication Error

A communication error occurred during a fax transmission.

### Initial Actions

1. Call the target fax number to confirm a fax response.
2. Check condition of the fax line and connection.
3. Verify that the fax line is an analog phone line.
4. Switch off, then switch on the machine
5. Verify that the country setting is correct.
6. Resend the fax job.
7. Check fax communications to a different machine.

### WARNING

**Do not perform repair activities with the power on or electrical power supplied to the machine. The machine could activate and cause serious personal injury when the power is on or electrical power is supplied.**

**DANGER: Ne pas effectuer de dépannage avec le contact principal activé ou avec l'alimentation électrique appliquée à la machine: celle-ci pourrait démarrer et causer de graves blessures.**

**AVVERTENZA: Non effettuare alcuna riparazione con la macchina accesa o con l'alimentazione elettrica inserita. La macchina potrebbe avviarsi all'improvviso e causare gravi ferite.**

**VORSICHT: Es dürfen keine Reparaturarbeiten durchgeführt werden, solange das Gerät eingeschalten oder mit der Stromquelle verbunden ist. Das Gerät kann u.U in den Aktiv-Zustand übergehen und somit erhebliche körperliche Schäden verursachen.**

**AVISO: No realice reparaciones con la máquina encendida o conectada a la corriente. La máquina podría activarse y ocasionar daños personales graves.**

### Procedure

Enter Diagnostic Mode. From the Control panel, select: **[Report, Error Info, Print]** to print the Error Information Report. **The target fax is causing the error.**

**Y N**

In Diagnostics, select: **[Report, Fax Options]** to verify Fax Send settings are at default.

Check that the Target Fax configuration is OK. **The Target Fax is OK.**

**Y N**

Reconfigure Target Fax.

Reseat the Fax PWB. **The fault clears.**

**Y N**

Install a new Fax PWB, [PL 2.2 Item 3](#).

**A**

Check the connection between the Fax board and the Main PWB. **The connection is secure.**

**Y N**

Firmly reconnect the connector.

Install a new Main PWB, [PL 1.1 Item 4](#).



## 20-120 Scanning Error RAP

BSD-ON:[BSD 2](#)

### Control Panel Fault Displayed

B205: NA

B215: Scanner Error

A error such as a paper jam or scanner fault has occurred during a manual-dial fax operation.

### Procedure

Clear any jammed sheets. Refer to the Xerox® B205/B215 User Guide for detailed jam clearance instructions.

## 20-300 Incompatible (FAX) RAP

### Control Panel Fault Displayed

B205: Junk Fax

B215: Fax was not Received

Remote party did not have the requested feature, such as poling.

### Procedure

- Adjust the machine settings to be more compatible to the receiving end, then resend the fax.

## 20-400 / 410 Line RAP

### Control Panel Fault Displayed

20-400 Line Busy

B205: Line Busy

B215: Fax Line is Busy

20-410 Line Error

B205: Line Error

B215: Fax Connection Error

Unable to connect with the remote machine. The fax line is busy or an error has occurred with fax transmission due to a phone line problem.

### Procedure

Resubmit fax job. If fault persists, resubmit after an hour.

## 20-500 Memory Full RAP

### Control Panel Fault Displayed

B205: Memory Full Remove Job

B215: Fax Memory is Full

The memory is full.

### Procedure

Delete necessary documents. Send the job again when memory becomes available or split the transmission into multiple operations.

## **20-600 No Answer RAP**

### **Control Panel Fault Displayed**

B205: No Answer

B215: No Answer after Redial

The printer unable to connect to remote machine after maximum redial attempts.

### **Procedure**

Ensure that remote machine is powered on and reattempt submission.

---

## 3 Image Quality

Image Quality Overview .....	3-3
IQ1 Vertical Black Line and Band RAP .....	3-4
IQ2 Vertical White Line and Band RAP .....	3-5
IQ3 Horizontal Black Bands RAP .....	3-5
IQ4 Spots RAP .....	3-6
IQ5 Low Image Density RAP .....	3-6
IQ6 Black or Dark Image RAP .....	3-7
IQ7 Uneven Density RAP .....	3-8
IQ8 Background RAP .....	3-9
IQ9 Residual Image (Ghosting) RAP .....	3-9
IQ10 Side 2 Staining .....	3-10
IQ11 Blank Page RAP .....	3-10
IQ12 Partial Image Deletions RAP .....	3-11



## Image Quality Overview

Image quality defects can be attributed to printer components, consumables, media, internal software, external software applications, and environmental conditions. To successfully troubleshoot print-quality problems, eliminate as many variables as possible.

If the print-quality defect is still present after printing on approved media from an unopened ream of paper, investigate software applications and environmental conditions. Check the temperature and humidity under which the printer is operating. Compare this to the Environmental Specifications listed in Section 6.

When analyzing a imaging defect, determine if the defect is repeating or random. Check the Supplies Information Report for end of life conditions. Inspect the visible surfaces of all rollers for obvious defects. If a cursory inspection does not reveal any obvious defects, continue troubleshooting the defect.

### WARNING

**Do not perform repair activities with the power on or electrical power supplied to the machine. Some machine components contain dangerous electrical voltages that can result in electrical shock and possible serious injury.**

**DANGER: Ne pas effectuer de dépannage avec le contact principal activé ou avec l'alimentation électrique appliquée à la machine. Certains éléments de la machine comportent des tensions électriques dangereuses qui peuvent causer un choc électrique et de graves blessures.**

**AVVERTENZA: Non effettuare alcuna riparazione con l'alimentazione elettrica inserita. Alcuni componenti contengono corrente ad alta tensione che può provocare forti scosse e gravi ferite.**

**VORSICHT: Es dürfen erst Reparaturarbeiten durchgeführt werden, wenn das Gerät ausgeschaltet ist oder der Netzstecker nicht mehr mit der Stromquelle verbunden ist. Einige Komponenten des Gerätes sind stromführend und können daher zu ernsthaften Verletzungen oder Stromschlägen führen.**

**AVISO: No realice reparaciones con la máquina encendida o conectada a la corriente. Algunos componentes de la máquina contienen voltajes eléctricos peligrosos que pueden producir una descarga eléctrica y causar daños graves.**

### Defects Associated with Specific Components

To aid with diagnosis, the list below outlines image defects associated with specific components.

#### Laser Scanner Unit:

- Black Print
- Vertical white lines
- Curved lines

#### Transfer Roller:

- Uneven Density
- Background contamination
- Ghosting
- Vertical white lines
- Vertical black line or band

- Stains on the page back

#### Fuser:

- Ghosting
- Stains on the page back or front
- Poor image adhesion

#### Drum Cartridge:

- Uneven density
- Background contamination
- Spots, smudges, or smears
- Ghosting
- Vertical white lines
- Vertical black line or band
- Stains on the page front
- Blank prints
- Black prints
- Horizontal Black lines or bands

After determining the defect type and possible source, match the defect with those listed in Table 1. Go to the RAP listed to correct the defect.

## Image Defect Definitions

Table 1, lists image defect definitions and the RAP used to correct the problem.

Table 1 Image Defect Definitions

Defect	Definition	Go To
Vertical Black Line and Band	Vertical black lines or bands occur in the printed image.	IQ1
Vertical White Line and Band	Vertical white lines or bands occur in the printed image.	IQ2
Horizontal Black Band	Periodic dark or blurry horizontal bands in the printed image.	IQ3
Spots	Random or periodic dark areas in the low density areas of a print, or voids in the dark areas of a print.	IQ4
Low Image Density	Printed image is light with no ghosting.	IQ5
Black or Dark Image	Printed image is totally dark or black.	IQ6
Uneven Density	Print density is uneven between the left and right portion of the printed image.	IQ7
Background	Uniform toner contamination in most or all non-image areas.	IQ8
Residual Image (Ghosting)	The image from a previous print appears on the current print.	IQ9
Side 2 Staining	Side two of a simplex or duplex print is stained.	IQ10
Blank Page	The entire image area is blank.	IQ11
Partial Image Deletions	Areas of the printed image are light or missing entirely on limited areas of the paper.	IQ12

## Test Prints

Test Pattern pages are available for troubleshooting image quality defects and to confirm proper printer operation. Printing the Test Pattern is useful for stimulating asynchronous (dynamic) events related to the print process, or as a test for media path and media-related problems.

The test print provides a variety of different line styles in both process and cross-process directions. The pattern is used to check registration, dot size and image density.

Test Pattern 1 and Test Pattern 2 are essentially the same but for different media sizes. [Table 2](#), describes the test patterns and the purpose for which they are used to identify image quality defects.

**Table 2 Internal Test Patterns**

Test Pattern Number	Description	Purpose
Test Pattern 1	8.5 x 11 inches (Letter)	Light density uniformity, deletions, lines, bands, streaks, smears, solid area reproduction, motion quality (LSU).
Test Pattern 2	A4	Light density uniformity, deletions, lines, bands, streaks, smears, solid area reproduction, motion quality (LSU).

To create a test print from the Control Panel:

1. Enter Diagnostic Mode. Press the <Menu> button, the <#> button, then using the keypad select <1934>, then press the <OK> button.
2. Select: [**Diagnostics, Machine Test, Test Pattern, Print, Yes**]. Press the <OK> button after menu selections.
  - Test Pattern 1 for 8.5 x 11 prints.
  - Test Pattern 2 for A4 prints.

## IQ1 Vertical Black Line and Band RAP

Thin black vertical lines or black vertical bands occur in the printed image, [Figure 1](#).

### Procedure

Switch Off the power.

Check the Transfer Roller, [PL 4.1 Item 10](#), for wear or damage; and remaining life, refer to [GP 6](#) Machine Reports. **The Transfer Roller is OK.**

Y N

Install a new Transfer Roller, [PL 4.1 Item 10](#).

Switch On the power and make a test print.

If the fault persists, Install a new Drum Cartridge, refer to the Xerox® B215/B205 User Guide for detailed instructions on how to Install a new Drum Cartridge.



0300101bat

**Figure 1 Black Lines and Bands**

## IQ2 Vertical White Line and Band RAP

Thin white vertical lines or white vertical bands occur in the printed image, [Figure 1](#).

### Initial Actions

Clean the surface of the LSU window with a clean cotton swab and recommended cleaner.

### Procedure

Check the life of the Drum Cartridge, refer to [GP 6](#), Machine Reports. **The Drum Cartridge has reached end of life.**

Y N

Switch Off the power. Install a new Drum Cartridge. Refer to the Xerox® B215/B205 User Guide for detailed instructions on how to Install a new Drum Cartridge.

Check the space between the LSU and the Drum Cartridge, remove any debris or blockage.

**The defect is gone.**

Y N

Install a new Fuser Module, [PL 5.1 Item 26](#).

Switch on the power. Perform Final Actions.



Figure 1 White Lines and Bands

0300102bat

## IQ3 Horizontal Black Bands RAP

Periodic dark or blurry horizontal stripes in the printed image, [Figure 1](#).

### Procedure

- Switch Off the power.
- Check high voltage contacts between the Drum Cartridge and the HVPS PWB for contamination or damage.
- Switch On the power and make a test print.

**The defect is still present.**

Y N

Go to Call Closeout.

Refer to Xerox® B215/B205 User Guide for detailed instructions on how to Install a new Drum Cartridge or Toner Cartridge.

- Install a new Drum Cartridge.
- Install a new Toner Cartridge.



Figure 1 Horizontal Black Bands

0300103bat



## IQ4 Spots RAP

Random or periodic dark areas in the low density areas of a print, or voids in the dark areas of a print, [Figure 1](#).

### Initial Actions

Ensure that the Drum Cartridge is firmly seated.

### Procedure

Check the Transfer Roller for wear, damage; and remaining life, refer to [GP 6](#) Machine Reports. **The Transfer Roller is OK.**

**Y N**  
Install a new Transfer Roller, [PL 4.1 Item 10](#).

Switch off the power.

Clean the contacts on the following components:

- Toner Cartridge
- Drum Cartridge
- HVPS PWB

Switch on the power and make a test print. **The test print looks OK.**

**Y N**  
Install a new Toner Cartridge. Refer to the Xerox® B215/B205 User Guide for detailed instructions on how to Install a new Toner Cartridge.

If the fault persists, Install a new Fuser Module, [PL 5.1 Item 26](#).



0300104bat

Figure 1 Black Spots

## IQ5 Low Image Density RAP

The printed image is light, with no ghosting, [Figure 1](#).

### Initial Actions

Remove Toner Cartridge. Rotate the cartridge 5-6 full rotations to redistribute the toner. Make a test print.

Check the life of the Toner Cartridge, refer to [GP 6](#) Machine Reports. Install a new Toner Cartridge if it has reached end of life, refer to the Xerox® B215/B205 User Guide for detailed instructions on how to Install a new Toner Cartridge.

If the problems continue, follow the procedure.

### Procedure

- Switch off the power.
- Clean the terminals on the HVPS PWB and the Toner Cartridge.
- Switch on the power and make a test print.

**The problem continues.**

**Y N**  
Go to Call Closeout.

Install a new HVPS PWB, [PL 4.1 Item 2](#).



0300105bat

Figure 1 Light Image

## IQ6 Black or Dark Image RAP

The printed image is totally dark or black, [Figure 1](#).

### Procedure

#### WARNING

Do not perform repair activities with the power on or electrical power supplied to the machine. Some machine components contain dangerous electrical voltages that can result in electrical shock and possible serious injury.

**DANGER:** Ne pas effectuer de dépannage avec le contact principal activé ou avec l'alimentation électrique appliquée à la machine. Certains éléments de la machine comportent des tensions électriques dangereuses qui peuvent causer un choc électrique et de graves blessures.

**AVVERTENZA:** Non effettuare alcuna riparazione con l'alimentazione elettrica inserita. Alcuni componenti contengono corrente ad alta tensione che può provocare forti scosse e gravi ferite.

**VORSICHT:** Es dürfen erst Reparaturarbeiten durchgeführt werden, wenn das Gerät ausgeschaltet ist oder der Netzstecker nicht mehr mit der Stromquelle verbunden ist. Einige Komponenten des Gerätes sind stromführend und können daher zu ernsthaften Verletzungen oder Stromschlägen führen.

**AVISO:** No realice reparaciones con la máquina encendida o conectada a la corriente. Algunos componentes de la máquina contienen voltajes eléctricos peligrosos que pueden producir una descarga eléctrica y causar daños graves.

- Switch off the power.
- Clean the contacts on the Toner Cartridge, Drum Cartridge, and HVPS PWB.
- Switch on the power and make a test print.

#### The problem continues.

Y N

- Go to Call Closeout.
- The Charge Roller is likely defective. Install a new Toner Cartridge, refer to the Xerox® B215/B205 User Guide for detailed instructions on how to Install a new Toner Cartridge.
- If the image is Black, Install a new HVPS PWB, [PL 4.1 Item 2](#).



0300106bat

Figure 1 Dark or Black Image

## IQ7 Uneven Density RAP

Print density is uneven between the left and right portion of the printed image, [Figure 1](#).

### Initial Actions

- Ensure that the printer is level.
- Check the life of the Toner Cartridge, refer to [GP 6 Machine Reports](#).  
Install a new Toner Cartridge if it has reached end of life, refer to the Xerox® B215/B205 User Guide for detailed instructions on how to Install a new Toner Cartridge.
- Remove the Toner Cartridge. Rotate the Toner Cartridge 5-6 full rotations to redistribute the toner.

### Procedure

#### WARNING

**Do not perform repair activities with the power on or electrical power supplied to the machine. Some machine components contain dangerous electrical voltages that can result in electrical shock and possible serious injury.**

**DANGER: Ne pas effectuer de dépannage avec le contact principal activé ou avec l'alimentation électrique appliquée à la machine. Certains éléments de la machine comportent des tensions électriques dangereuses qui peuvent causer un choc électrique et de graves blessures.**

**AVVERTENZA: Non effettuare alcuna riparazione con l'alimentazione elettrica inserita. Alcuni componenti contengono corrente ad alta tensione che può provocare forti scosse e gravi ferite.**

**VORSICHT: Es dürfen erst Reparaturarbeiten durchgeführt werden, wenn das Gerät ausgeschaltet ist oder der Netzstecker nicht mehr mit der Stromquelle verbunden ist. Einige Komponenten des Gerätes sind stromführend und können daher zu ernsthaften Verletzungen oder Stromschlägen führen.**

**AVISO: No realice reparaciones con la máquina encendida o conectada a la corriente. Algunos componentes de la máquina contienen voltajes eléctricos peligrosos que pueden producir una descarga eléctrica y causar daños graves.**

Switch Off the Power. Check the contacts on the Toner Cartridge and HVPS PWB for contamination. **The contacts are OK.**

**Y N**  
Clean the contacts or Install a new Toner Cartridge.

Check the Transfer Roller for wear or damage. **The Transfer Roller is OK.**

**Y N**  
Install a new Transfer Roller, [PL 4.1 Item 10](#).

If the fault persists, Install a new HVPS PWB, [PL 4.1 Item 26](#).



0300107bat

Figure 1 Uneven Density

## IQ8 Background RAP

Uniform toner contamination appears in most or all non-image areas of the printed sheet, [Figure 1](#).

### Initial Actions

- Check that media type settings are correct.
- Check that the paper meets specifications. Refer to Section 6 for product specifications.
- Check the life of the Toner Cartridge, refer to [GP 6 Machine Reports](#).  
Install a new Toner Cartridge if it has reached end of life, refer to the Xerox® B215/B205 User Guide for detailed instructions on how to Install a new Toner Cartridge.

### Procedure

- Switch off the power.
- Clean the contacts on the Print Cartridge, Toner Cartridge, and HVPS PWB.
- Switch on the power and make a test print.

The test print looks OK.

Y N  
| Install a new HVPS PWB, [PL 4.1 Item 2](#).

Go to Call Closeout.



0300108bat

Figure 1 Background

## IQ9 Residual Image (Ghosting) RAP

The image from a previous print appears on the current print, [Figure 1](#).

### Procedure

- Switch Off the Power.  
Check the Transfer Roller, [PL 4.1 Item 10](#) for the following:
- Wear or damage.
  - The left and right tension springs for damage.
  - Be sure all parts are installed correctly.

The Transfer Roller is OK.

Y N  
| Install a new Transfer Roller, [PL 4.1 Item 10](#).

If the fault persists, replace components in the following order:  
Refer to the Xerox® B215/B205 User Guide for detailed instructions on how to Install a new Drum Cartridge or Toner Cartridge.

- Drum Cartridge
- Toner Cartridge
- Fuser Module, [PL 5.1 Item 26](#).
- HVPS PWB, [PL 4.1 Item 2](#).



0300109bat

Figure 1 Ghost Image

## IQ10 Side 2 Staining

Side 2 of a simplex or duplex print is stained, [Figure 1](#).

### Procedure

Switch Off the Power.

Check the Transfer Roller, [PL 4.1 Item 10](#), for:

- Wear or damage.
- The left and right tension springs for damage.
- Be sure all parts are installed correctly.

**The Transfer Roller is OK.**

Y N

Install a new Transfer Roller, [PL 4.1 Item 10](#).

If the fault persists, Install a new Fuser Module, [PL 5.1 Item 26](#).

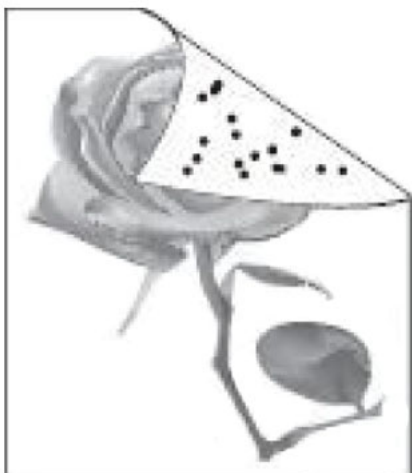

Figure 1 Side 2 Staining

0300110bat

## IQ11 Blank Page RAP

The entire image area is blank, [Figure 1](#).

### Initial Actions

Replace any components at end of life, refer to [GP 6 Machine Reports](#).

### Procedure

- Switch Off the power.
- Check the space between the LSU and the Drum Cartridge, remove any debris or blockage.
- Clean the terminals on the Toner Cartridge, Drum Cartridge, and the HVPS PWB.
- Switch on the power and make a test print.

**The problem continues.**

Y N

Go to Call Closeout.

Install a new Drum Cartridge, refer to the Xerox® B215/B205 User Guide, Section 6 Maintenance, General Care, for detailed instructions on how to Install a new Drum Cartridge. **The problem continues.**

Y N

Go to Call Closeout.

Check the circuit between the Main PWB and the HVPS PWB, refer to [BSD 1. Main/Electrical/Power/Drive/LSU/Fuser/Network](#), **The circuit is OK.**

Y N

Replace any defective components:

- Main PWB to LVPS / HVPS PWB Wire Harness.
- Main PWB, [PL 1.1 Item 4](#).
- HVPS PWB, [PL 4.1 Item 10](#).

Go to Call Closeout.

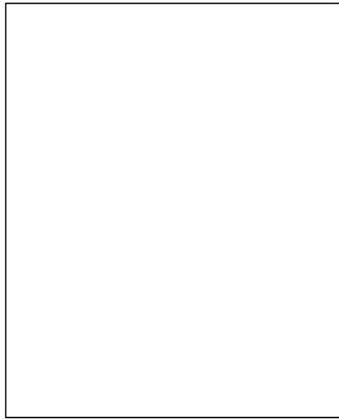

0300111bat

**Figure 1 Blank Image**

## IQ12 Partial Image Deletions RAP

Areas of the printed image are light or missing entirely on limited areas of the paper, [Figure 1](#).

### Initial Actions

Be sure the printer is installed on a level surface.

### Procedure

Procedure

- Switch Off the Power.
- Remove the Toner Cartridge.
- Rotate the Toner Cartridge side to side for 5 to 6 full rotations to redistribute the toner.
- Reinstall and print 10 test copies.

**The problem continues.**

**Y N**

Go to Call Closeout.

Switch Off the Power.

Check the Transfer Roller, [PL 4.1 Item 10](#), for:

- Wear or damage.
- The left and right tension springs for damage.
- Be sure all parts are installed correctly.



0300112bat

**Figure 1 Image Deletions**



## 4 Repairs / Adjustments

REP 1.1 Main PWB.....	4-3
REP 1.2 ADF / Scanner Assembly.....	4-4
REP 1.3 ADF Hinges .....	4-6
REP 1.4 Automatic Document Feeder (ADF) .....	4-6
REP 1.5 ADF Feed Roll Assembly.....	4-7
REP 1.6 ADF Drive Motor .....	4-8
REP 1.7 ADF Retard Pad .....	4-9
REP 2.1 Front Cover.....	4-11
REP 2.2 Left and Right Side Covers.....	4-12
REP 2.3 Rear Cover .....	4-13
REP 2.4 Manual Feed Cover .....	4-14
REP 2.5 Middle Covers.....	4-15
REP 2.6 FAX PWB (B215 only) .....	4-17
REP 2.7 WiFi PWB .....	4-18
REP 4.1 HVPS (High Voltage Power Supply).....	4-19
REP 4.2 LVPS (Low Voltage Power Supply) .....	4-20
REP 4.3 Feed and Registration Clutches / Paper Feed PWB .....	4-21
REP 4.4 Transfer Roll .....	4-21
REP 4.5 LSU and Cables.....	4-22
REP 4.6 Duplex.....	4-23
REP 4.7 Output Tray Full Sensor.....	4-24
REP 4.8 Exit Roll and Bushings.....	4-25
REP 4.9 Registration Roll .....	4-26
REP 4.10 Paper Feed Sensors PWB and Actuators .....	4-35
REP 4.11 Manual Paper Tray .....	4-38
REP 4.12 Exit Sensor .....	4-39
REP 4.13 Paper Drive Roll.....	4-40
REP 4.14 Paper Feed Roll Assembly .....	4-44
REP 4.15 Main Drive Motor .....	4-46
REP 4.16 Paper Feed Idler Gear.....	4-51
REP 4.17 Main Drive Unit .....	4-52
REP 4.18 Pick Up Assembly.....	4-53
REP 5.1 Fuser Module.....	4-55
REP 6.1 Retard Roll.....	4-57
REP 7.1 Bracket - Connector.....	4-58
REP 7.2 Scanner Module.....	4-61
REP 8.1 Control Panel (B205) .....	4-63
REP 8.2 Control Panel PWB (B205) .....	4-64
REP 8.3 Control Panel (B215) .....	4-64
REP 8.4 Control Panel PWB (B215) .....	4-66
REP 8.5 Home Key / Power Key / LCD Screen (B215) .....	4-68





## REP 1.1 Main PWB

### Parts List on PL 1.1

#### Removal

#### WARNING

Do not perform repair activities with the power on or electrical power supplied to the machine. Some machine components contain dangerous electrical voltages that can result in electrical shock and possible serious injury.

**DANGER:** Ne pas effectuer de dépannage avec le contact principal activé ou avec l'alimentation électrique appliquée à la machine. Certains éléments de la machine comportent des tensions électriques dangereuses qui peuvent causer un choc électrique et de graves blessures.

**AVVERTENZA:** Non effettuare alcuna riparazione con l'alimentazione elettrica inserita. Alcuni componenti contengono corrente ad alta tensione che può provocare forti scosse e gravi ferite.

**VORSICHT:** Es dürfen erst Reparaturarbeiten durchgeführt werden, wenn das Gerät ausgeschaltet ist oder der Netzstecker nicht mehr mit der Stromquelle verbunden ist. Einige Komponenten des Gerätes sind stromführend und können daher zu ernsthaften Verletzungen oder Stromschlägen führen.

**AVISO:** No realice reparaciones con la máquina encendida o conectada a la corriente. Algunos componentes de la máquina contienen voltajes eléctricos peligrosos que pueden producir una descarga eléctrica y causar daños graves.

1. Record the machine serial number from the Data Plate (located on the rear cover beneath the bar code) or from a Configuration Report printed prior to installing the new PWB. Refer to, [GP 2](#), Machine Reports.
2. Switch off the machine, then disconnect the power cord.
3. Remove the Right Side Cover, [REP 2.2](#).
4. Remove the Wifi PWB, [REP 2.7](#).
5. Remove the Main PWB, [Figure 1](#).
  - a. Disconnect all the connectors on the Main PWB.
  - b. Remove the screws (5) and the Main PWB.

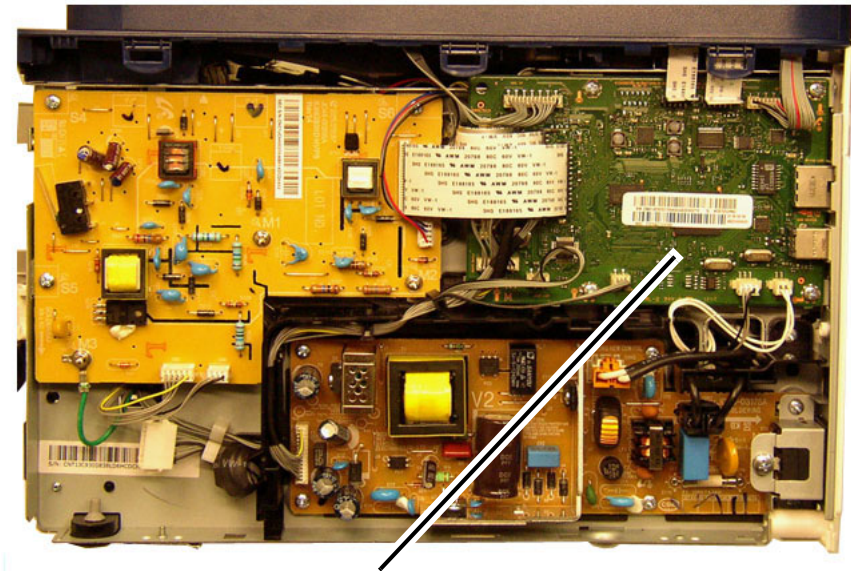

Main PWB

040411RBAT

Figure 1 Main PWB removal

#### Replacement

**NOTE:** Tapered plastic screws and round machine screws are used to hold the PWB to the frame. Make sure that the plastic screws go into plastic components and machine screws go into the metal frame.

The replacement is the reverse of the removal procedure.

After installing a new Main PWB, the following steps **MUST** be performed to write the machine serial number to the new Main PWB:

1. Reconnect the power cord, the switch on the machine.
2. Set the serial number to the original machine number recorded in Step 1 of the Removal procedure.
  - **B215**
    - a. Enter Diagnostics, [GP 1](#). Open [**Data Setup, Machine Data, Set Serial Number**], then enter the original serial number from Step 1. Touch **[OK]**.
  - **B205**
    - a. Enter Diagnostics [GP 1](#). Using the up and down arrows, enter: [**Data Setup, Machine Data, Set Serial Number**], then enter the original serial number from Step 1. Press the **[OK]** button.
3. Perform **<Clear All Memory>** in Diagnostics: [**Data Setup, Machine Data, Clear All Memory**].

4. After the machine restarts, print a Configuration Report, refer to [GP 2 Machine Reports](#), then verify the original machine serial number is displayed under the [Device Profile] heading.

**NOTE:** Performing a **[Clear All Memory]** sets the SA Password back to the default value (device serial number). Inform the customer to reset SA Password as desired.

**NOTE:** After performing a Memory Clear, inform the customer that they will need to re-establish their Wireless or Ethernet connection.

## REP 1.2 ADF / Scanner Assembly

Parts List on [PL 1.1](#)

### Removal

1. Switch off the printer, then disconnect the power cord.
2. Remove the Control Panel, [REP 8.2 \(B205\)](#), [REP 8.2 \(B215\)](#).
3. Remove the Right Side Cover, [REP 2.2](#).
4. Remove the ADF / Scanner Assembly:
  - a. Remove two screws at the rear of the middle cover, [Figure 1](#).



N-1-0001-A

Figure 1 ADF / Scanner screws removal

- b. Disconnect the harnesses from the Main PWB to the ADF / Scanner Assembly and the ground screw, [Figure 2](#).

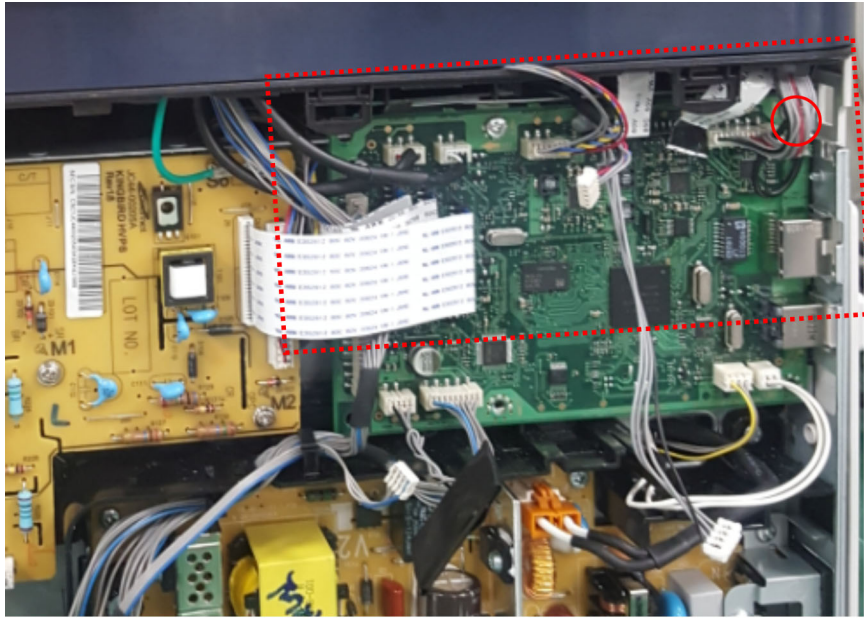

N-1-0004-A

Figure 2 Disconnect harnesses and ground wire

- c. Slide the ADF /Scanner Assembly to the front, then lift and remove the ADF / Scanner Assembly from the IOT, [Figure 3](#).

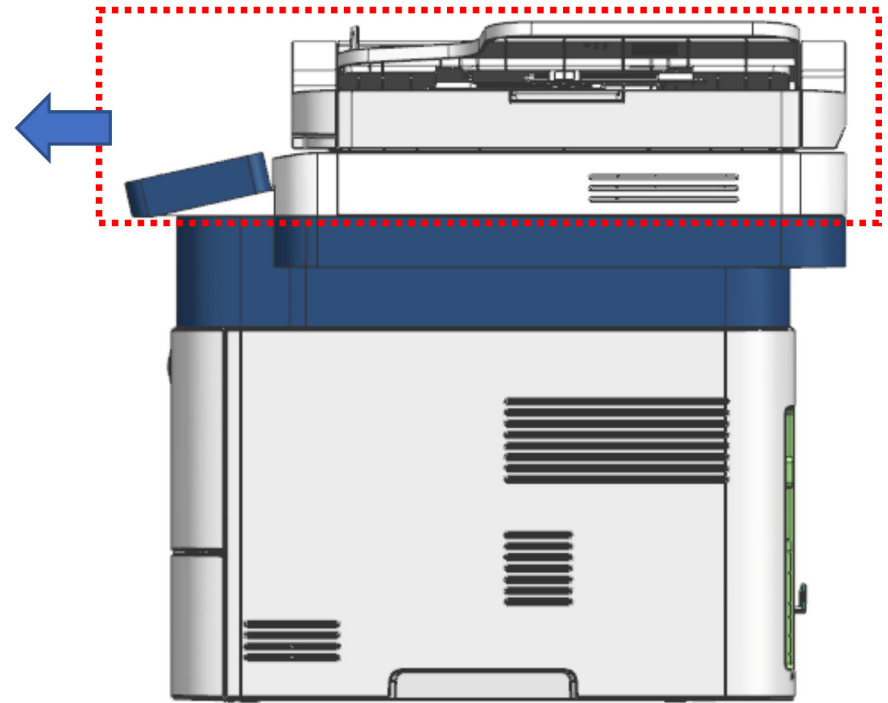

N-1-0005-A

Figure 3 ADF / Scanner Assembly Removal

### Replacement

The replacement is the reverse of the removal procedure.

## REP 1.3 ADF Hinges

Parts List on [PL 1.1](#)

### Removal

1. Switch off the printer, then disconnect the power cord.
2. Remove the ADF, [REP 1.3](#).
3. Remove four screws, then remove the hinges, [Figure 1](#).

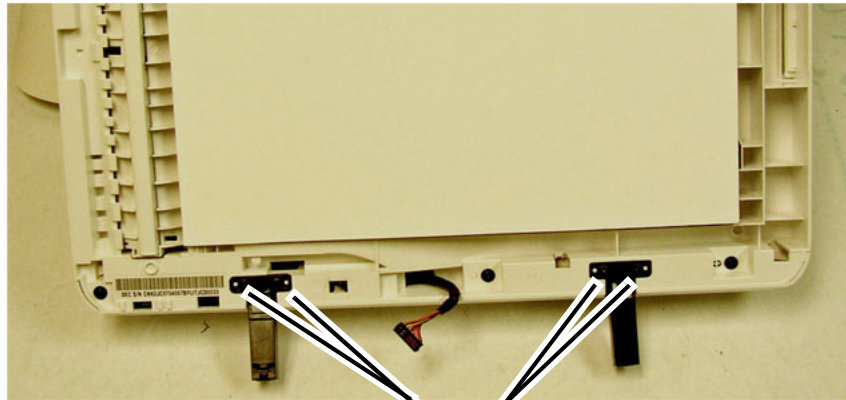

Figure 1 ADF Hinges removal

040418RBAT

### Replacement

The replacement is the reverse of the removal procedure.

## REP 1.4 Automatic Document Feeder (ADF)

Parts List on [PL 1.2](#)

### Removal

1. Switch off the printer, then disconnect the power cord.
2. Open and lift the ADF up.
3. Unlatch, then remove the Connector Cover, [Figure 1](#).

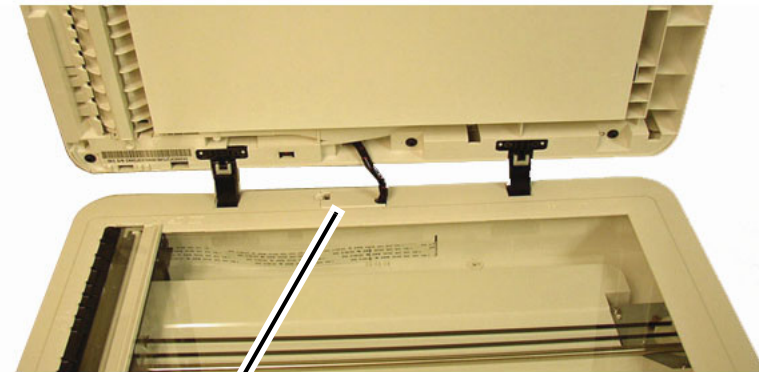
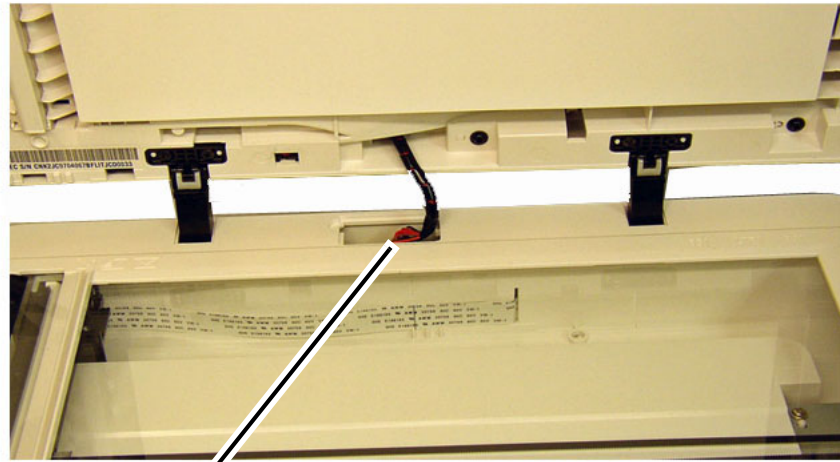

Figure 1 ADF Connector Cover removal

040404RBAT



4. Disconnect the connector, then lift the ADF off of the Printer, [Figure 2](#).



ADF Connector

040405RBAT

Figure 2 ADF connector disconnection

### Replacement

The replacement is the reverse of the removal procedure.

## REP 1.5 ADF Feed Roll Assembly

Parts List on [PL 1.2](#)

### Removal

1. Lift the ADF Cover, release two Rear Pivots, then remove the ADF cover, [Figure 1](#).

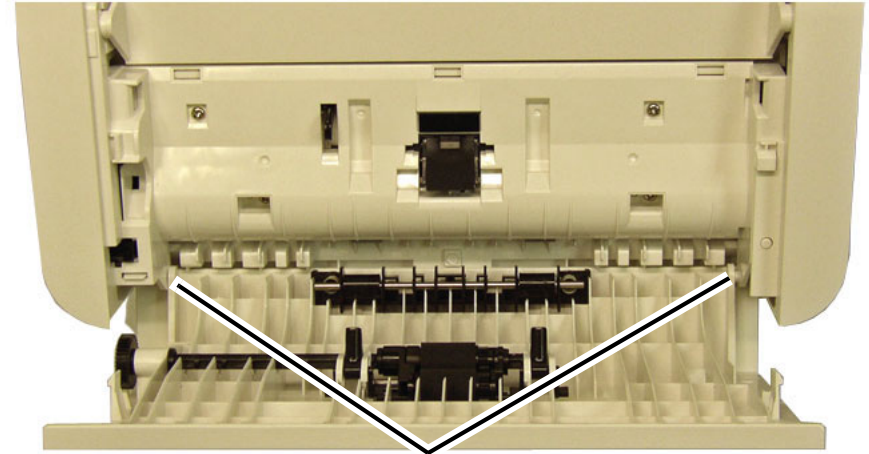

Rear Pivots

040409RBAT

Figure 1 ADF Cover Pivots (Top View)

2. Remove the Document Feed Roll Assembly, [Figure 2](#):
  - a. Remove three E-Rings.
  - b. Slide the drive shaft out of the Feed Roll Assembly.

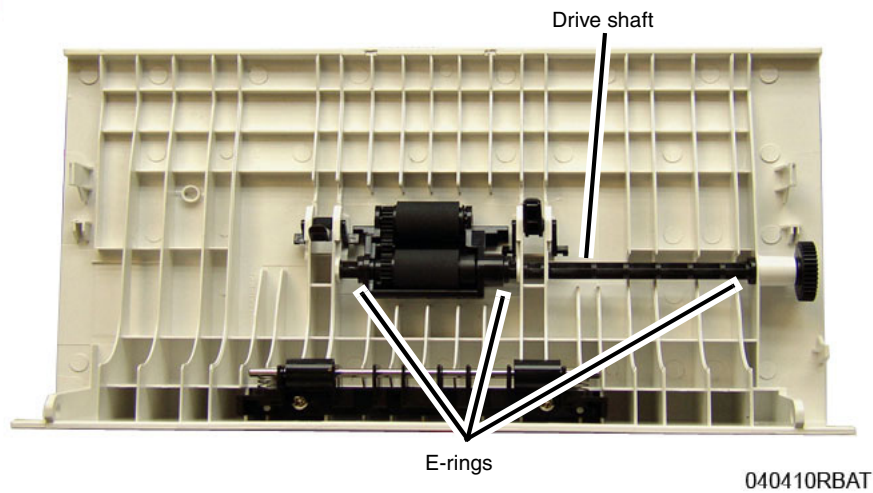

**Figure 2 Feed Roll E-rings**

### Replacement

The replacement is the reverse of the removal procedure.

**NOTE:** Install the E-rings in the following order:

1. The E-ring next to the gear.
2. The E-ring (center) next to the spring.
3. The E-ring at the end of the shaft.

## REP 1.6 ADF Drive Motor

Parts List on [PL 1.2](#)

### Removal

1. Switch off the printer, then disconnect the power cord.
2. Remove the ADF, [REP 1.3](#).
3. Remove the ADF Rear Cover, [Figure 1](#):
  - a. On the underside of the ADF, remove three Rear Cover screws.
  - b. Lift the top of the cover away from the ADF, then pull the bottom away to release the latches.

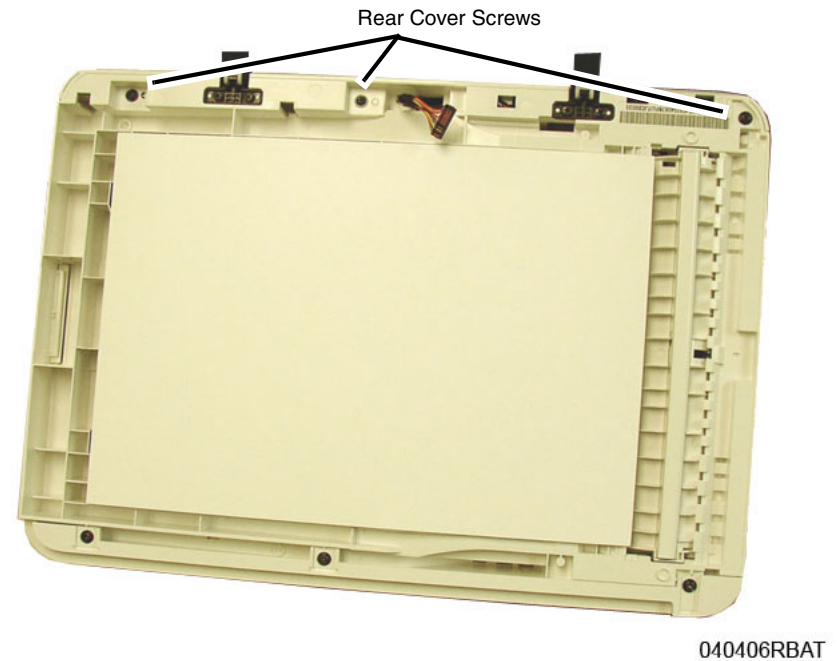

**Figure 1 Rear Cover Screws (Bottom View)**

4. Remove the ADF Drive Motor, [Figure 2](#):
  - a. Disconnect the connector.
  - b. Remove two screws, then remove the motor.

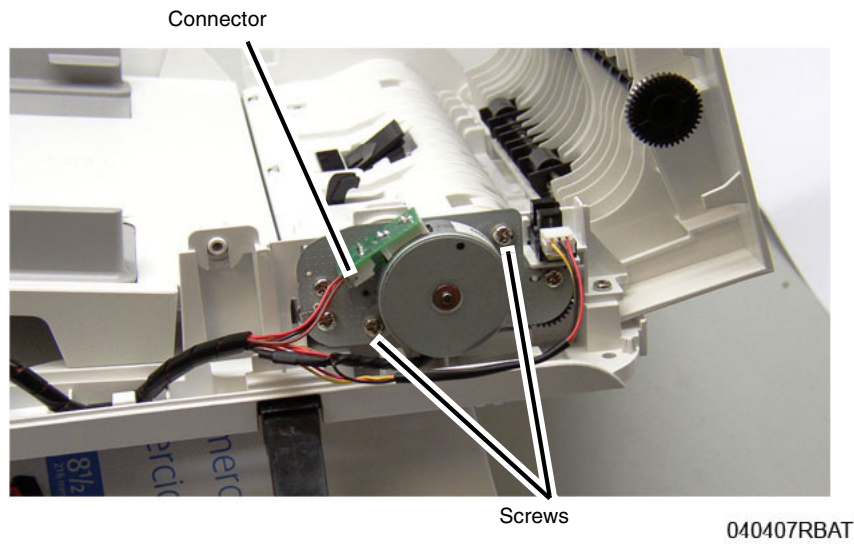

**Figure 2 ADF Drive Motor removal**

### Replacement

The replacement is the reverse of the removal procedure.

## REP 1.7 ADF Retard Pad

Parts List on [PL 1.2](#)

### Removal

1. Lift the ADF Cover, release two Rear Pivots, then remove the ADF Cover, [Figure 1](#).

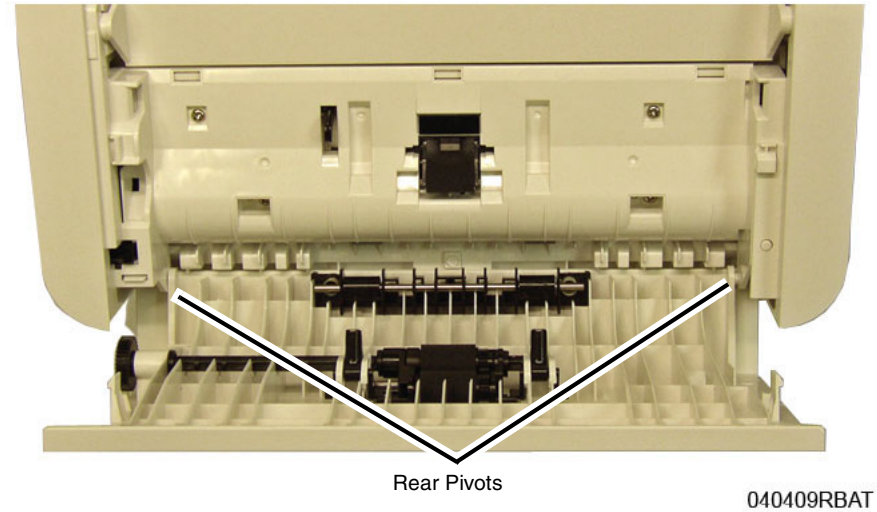
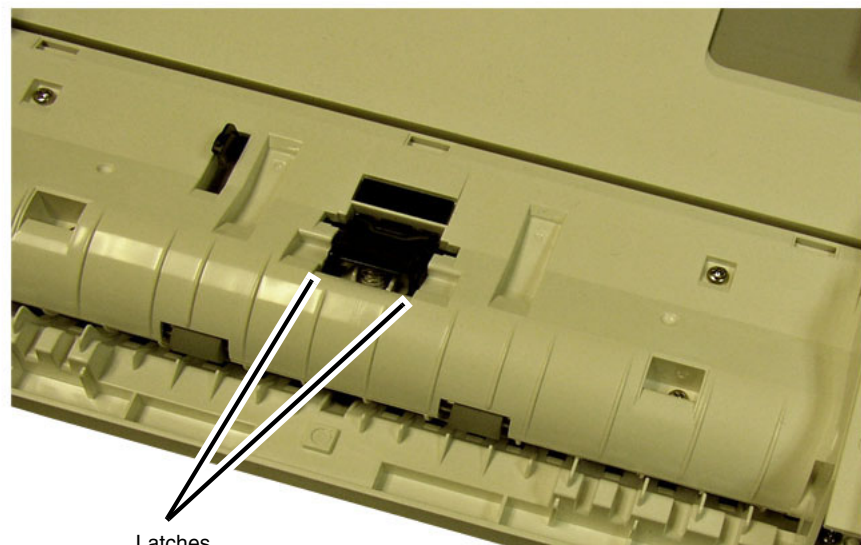

**Figure 1 ADF Cover Pivots (Top View)**



**NOTE:** The ADF Retard Pad has spring tension pushing up on it, be careful not to lose the spring.

2. Release two latches, then remove the ADF Retard Pad, [Figure 2](#).



Latches

040453RBAT

**Figure 2 ADF Retard Pad Latches (Top View)**

## Replacement

**NOTE:** Make sure the post on the ADF Retard Pad is positioned inside the spring, [Figure 3](#).

The replacement is the reverse of the removal procedure.

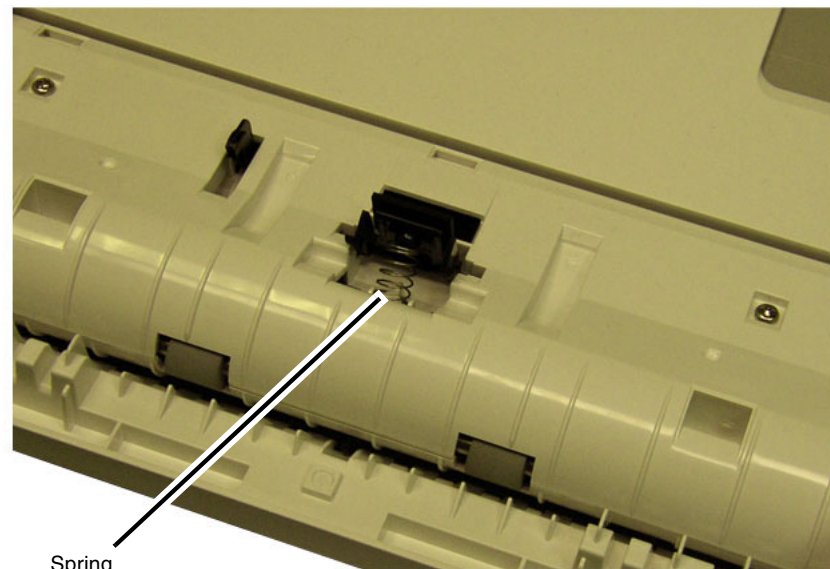

Spring

040454RBAT

**Figure 3 Separation Pad Spring and Post (Top View)**

## REP 2.1 Front Cover

### Parts List on PL 2.1

#### Removal

1. Switch off the machine, then disconnect the power cord.
2. Remove the Left and Right Side Covers, [REP 2.2](#).
3. Disconnect the connector from the wire harness to the Front Cover, [Figure 1](#).

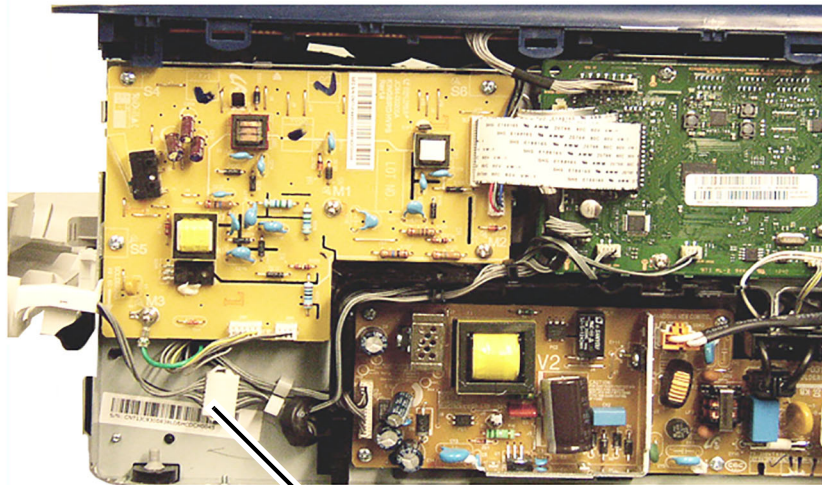

Connector

Figure 1 Front Cover P/J Connector

F-1-0001-A

4. Release the Front Cover Support Arm, [Figure 2](#).

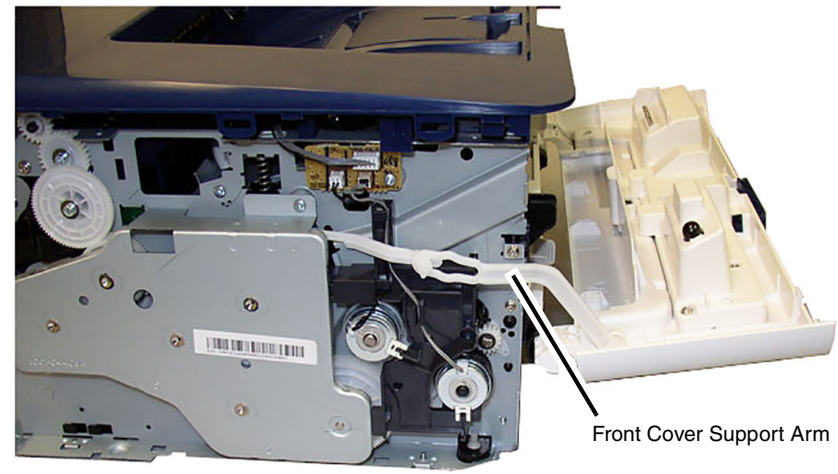

Front Cover Support Arm

Figure 2 Front Cover Support Arm

F-1-0002-A

**NOTE:** A wide blade flat screwdriver can be used to help release the Front Cover Pivot.

5. Release two Front Cover Pivots, then remove the cover, [Figure 3](#).

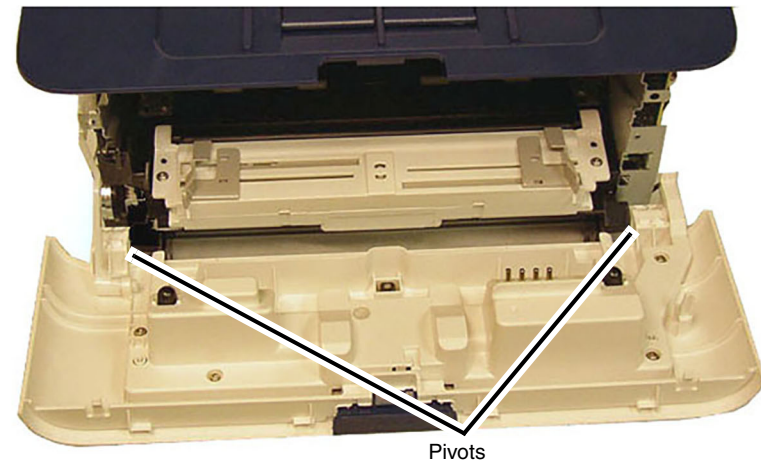

Pivots

Figure 3 Front Cover removal

F-1-0003-A

## Replacement

The replacement is the reverse of the removal procedure.

## REP 2.2 Left and Right Side Covers

Parts List on [PL 2.1](#)

### Removal

1. Remove the Paper Tray from the printer.

**NOTE:** Cover the Drum Cartridge with several sheets of paper to prevent it from being light shocked.

2. Open the Front Cover, then remove the Toner Cartridge and the Drum Cartridge, [Figure 1](#).

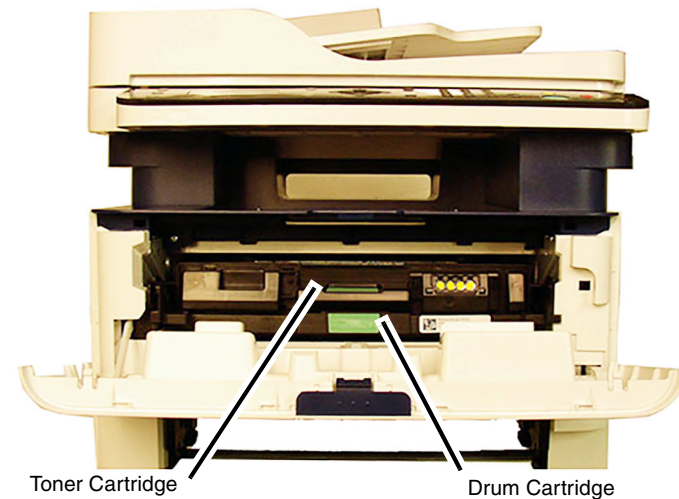

F-1-0005-A

**Figure 1 Toner Cartridge and Photoreceptor Handles**

**NOTE:** The side covers are held in place with plastic latches, release them carefully to avoid breakage. To release a latch press the hook end of the latch away from the part, [Figure 2](#).



F-1-0006-A

**Figure 2 Plastic latch release**

3. Remove the Right Side Cover, [PL 2.1](#).
  - a. Release (gently pull) the upper front cover to release the latch hook.
  - b. Release (gently pull) the lower front cover to release the latch hook.
  - c. Release the top latch hooks, then the bottom latch hooks on the bottom of the frame.
  - d. Remove the Right Side Cover.
4. Remove the Left Side Cover, [PL 2.1](#).
  - a. Release (gently pull) the upper front cover to release the latch hook.
  - b. Release (gently pull) the lower front cover to release the latch hook.
  - c. Release the top latch hooks, then the bottom latch hooks on the bottom of the frame.
  - d. Remove the Left Side Cover.

### Replacement

The replacement is the reverse of the removal procedure.

## REP 2.3 Rear Cover

Parts List on [PL 2.1](#)

### Removal

1. Remove the Left and Right Side Covers, [REP 2.2](#).
2. Remove four screws from the Rear Cover, [Figure 1](#).

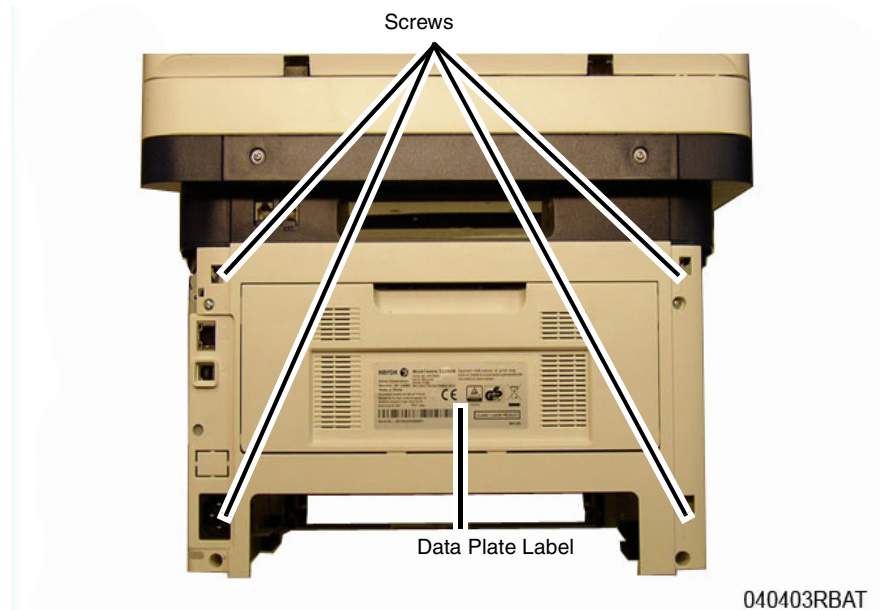
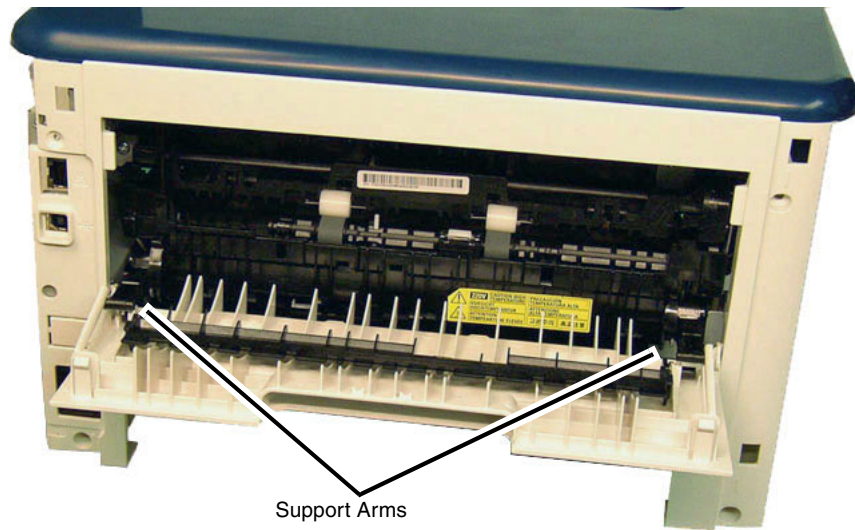

Figure 1 Rear Cover screws removal



3. Open the Rear Cover, then release the support arm on each side of the cover, [Figure 2](#).



040419RKB

Figure 2 Support Arms

4. Push down on the top of the Rear Cover to release the latch hooks, then remove the Rear Cover.

### Replacement

The replacement is the reverse of the removal procedure.

**Important:** When installing a new Rear Cover, remove the Data Plate Label from the old Rear Cover and install it onto the new Rear Cover, [Figure 1](#).

## REP 2.4 Manual Feed Cover

Parts List on [PL 2.1](#)

### Removal

1. Release two pivots, then remove the Manual Feed Cover, [Figure 1](#).



TagMatrix-BAT-KB

Figure 1 Manual Feed Cover (Top View)

### Replacement

1. The replacement is the reverse of the removal procedure.

**NOTE:** Remove the Tag Matrix from the old cover and install it on to the new Manual Feed Cover, [Figure 1](#).

## REP 2.5 Middle Covers

### Parts List on PL 2.2

#### Removal

1. Remove the Left and Right Side Covers, [REP 2.2](#).
2. Remove the ADF / Scanner Assembly, [REP 1.2](#).
3. Remove the Rear Cover, [REP 2.3](#).
4. Disconnect the WiFi PWB connector from the Main PWB, [Figure 1](#).

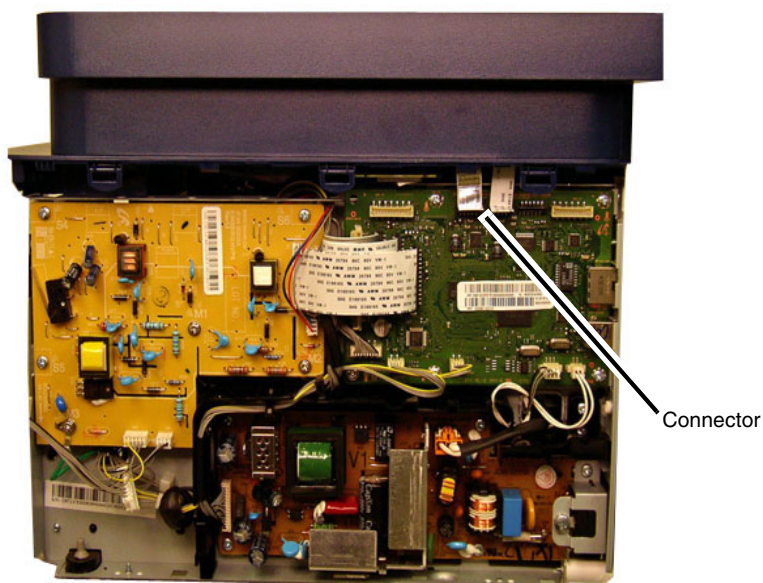

040442bRBAT

Figure 1 Wireless (WiFi) Connector (B215)

5. Disconnect the FAX PWB connector (B215), [Figure 2](#).

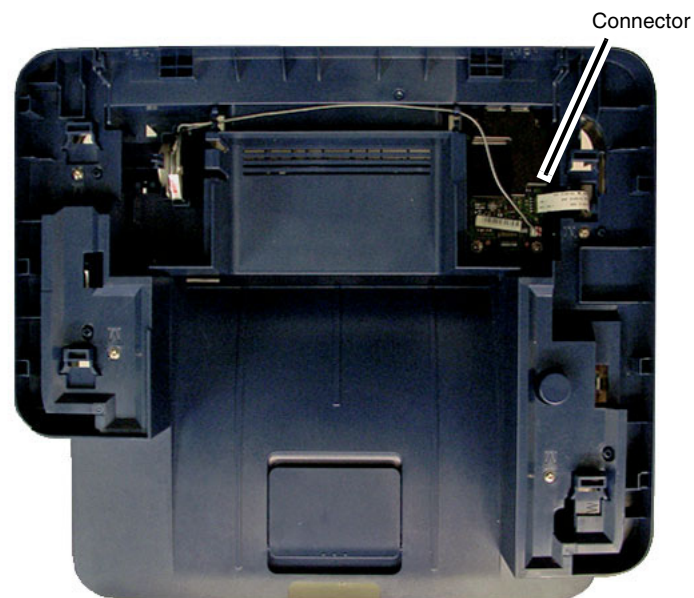

040420RBAT

Figure 2 FAX PWB connector (B215)

**NOTE:** When installing a new Middle Cover in the B215 machine; remove the FAX PWB, [REP 2.6](#), and the Speaker, [PL 2.2](#), from the old Middle Cover, then install to the new Middle Cover.

6. Remove three screws from top of the Middle Cover, [Figure 3](#).

**NOTE:** The screws are located at the bottom of the side cover openings.

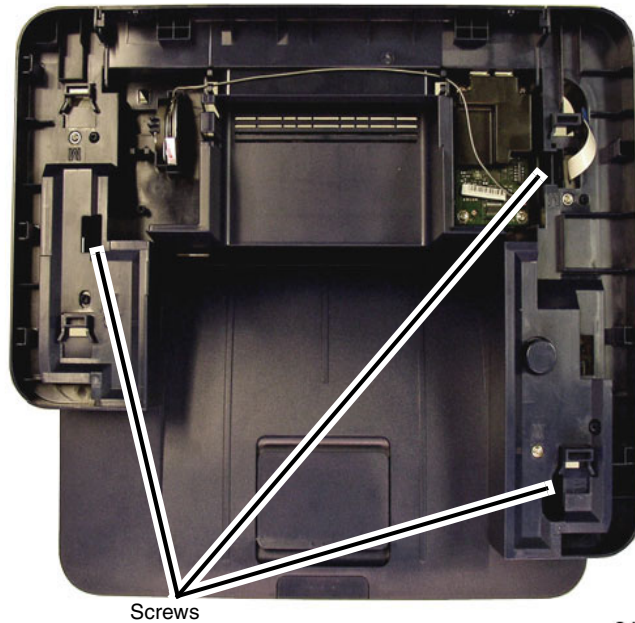

Figure 3 Middle Cover screws (Top View)

040420aRBAT

7. Remove two screws securing the rear of the Middle Cover, [Figure 4](#).

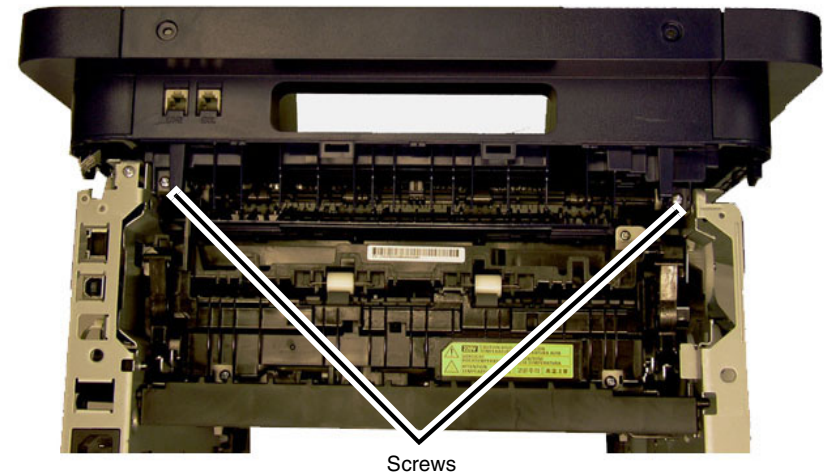

Figure 4 Middle Cover rear screws removal

040423RBAT

8. Release the latch next the front screw, then remove the Middle Cover.
9. Remove the screw securing the front, then remove the Middle Cover, [Figure 5](#).

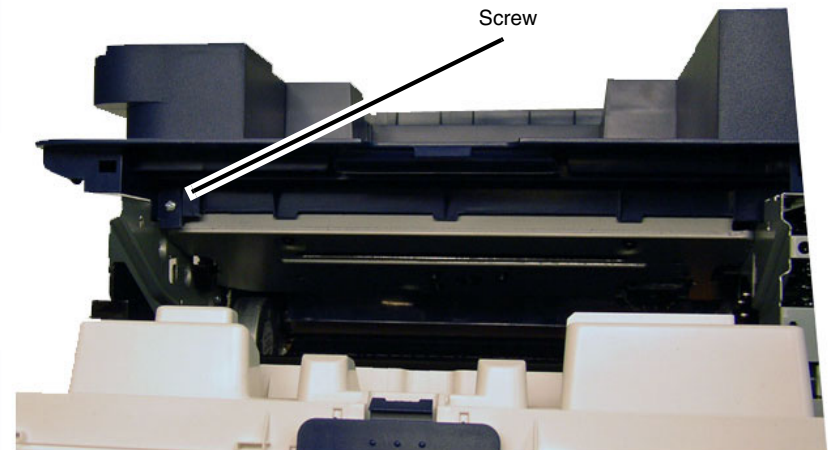

Figure 5 Middle Cover front screw removal

040422RBAT

## Replacement

The replacement is the reverse of the removal procedure.

**NOTE:** Tapered plastic screws and round machine screws are used to hold the cover to the frame. The plastic screws go into plastic components, the machine screws go into the metal frame.

## REP 2.6 FAX PWB (B215 only)

Parts List on [PL 2.2](#)

### Removal

1. Switch off the printer, then disconnect the power cord.
2. Remove the ADF / Scanner Assembly, [REP 1.2](#).
3. Remove the Fax PWB, [Figure 1](#):
  - a. Disconnect two connectors.
  - b. Remove four screws, then remove the FAX PWB.
  - c. Remove the cover from the FAX PWB.

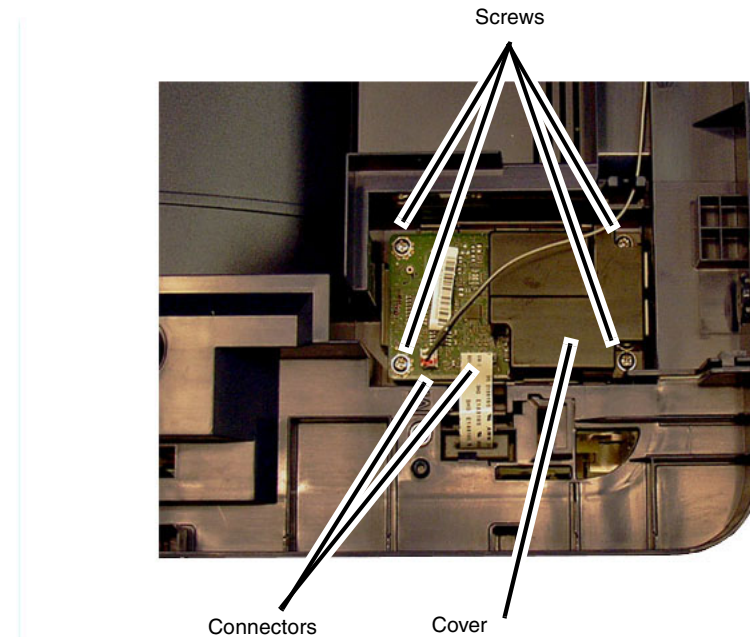

040419RBAT

Figure 1 FAX PWB removal

### Replacement

The replacement is the reverse of the removal procedure.



## REP 2.7 WiFi PWB

### Parts List on PL 2.2

#### Removal

1. Switch off the printer, then disconnect the power cord.
2. Remove the ADF / Scanner Assembly, REP 1.2.
3. Remove the screw, then disconnect the FFC from the FAX PWB, Figure 1.

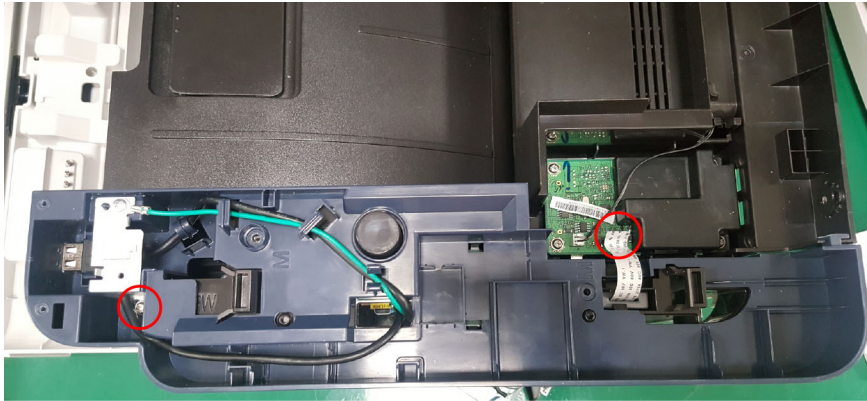

N-1-0006-A

Figure 1 FAX FFC removal

4. Remove the Cover-Middle Upper from the Middle Cover, Figure 2.

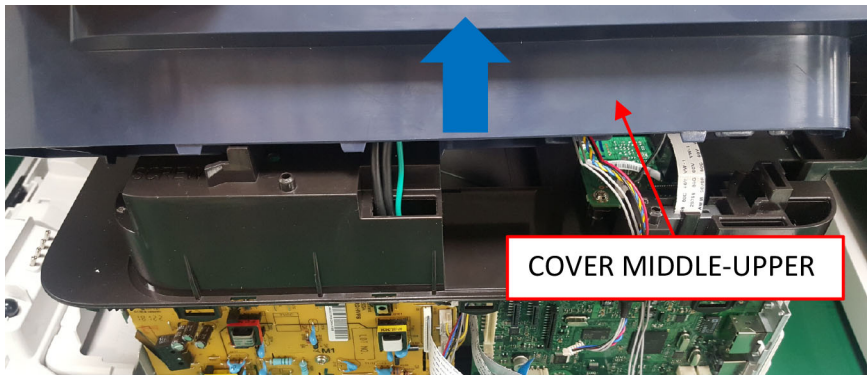

N-1-0007-A

Figure 2 Cover-Middle Upper removal

5. Disconnect the connect, release the WiFi PWB from the latches, then remove the WiFi PWB, Figure 3.

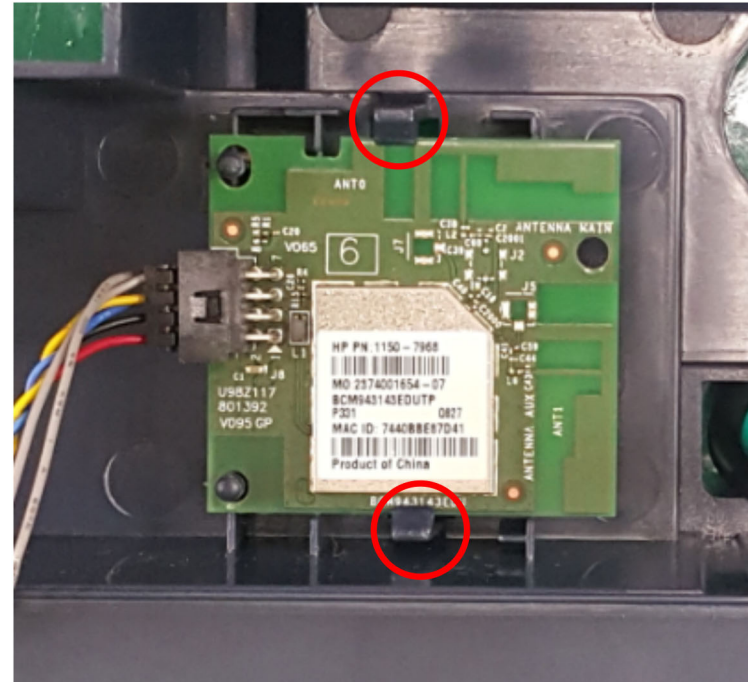

N-1-0008-A

Figure 3 WPNC (WiFi) PWB removal

#### Replacement

The replacement is the reverse of the removal procedure.

## REP 4.1 HVPS (High Voltage Power Supply)

### Parts List on PL 4.1

#### Removal

#### WARNING

Do not perform repair activities with the power on or electrical power supplied to the machine. Some machine components contain dangerous electrical voltages that can result in electrical shock and possible serious injury.

**DANGER:** Ne pas effectuer de dépannage avec le contact principal activé ou avec l'alimentation électrique appliquée à la machine. Certains éléments de la machine comportent des tensions électriques dangereuses qui peuvent causer un choc électrique et de graves blessures.

**AVVERTENZA:** Non effettuare alcuna riparazione con l'alimentazione elettrica inserita. Alcuni componenti contengono corrente ad alta tensione che può provocare forti scosse e gravi ferite.

**VORSICHT:** Es dürfen erst Reparaturarbeiten durchgeführt werden, wenn das Gerät ausgeschaltet ist oder der Netzstecker nicht mehr mit der Stromquelle verbunden ist. Einige Komponenten des Gerätes sind stromführend und können daher zu ernsthaften Verletzungen oder Stromschlägen führen.

**AVISO:** No realice reparaciones con la máquina encendida o conectada a la corriente. Algunos componentes de la máquina contienen voltajes eléctricos peligrosos que pueden producir una descarga eléctrica y causar daños graves.

1. Switch off the printer, then disconnect the power cord.
2. Remove the Right Side Cover, REP 2.2.

**NOTE:** When removing the HVPS PWB be careful not to lose the spring loaded contacts between the Print Cartridge and the HVPS PWB.

3. Remove the HVPS PWB, Figure 1:
  - a. Disconnect all the connectors on the HVPS PWB.
  - b. Remove six screws, then remove the HVPS PWB.

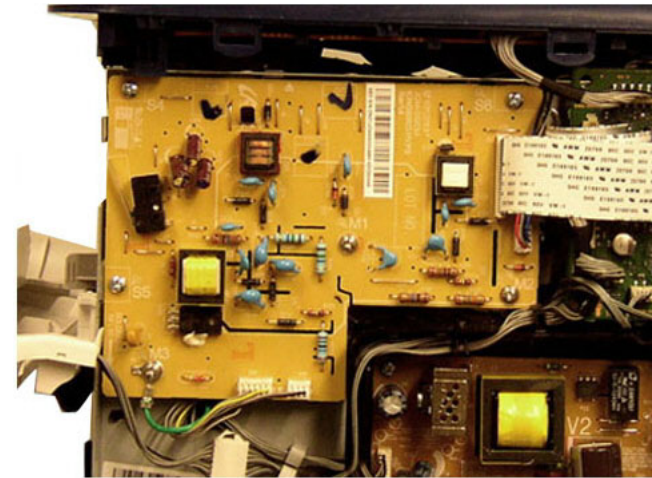

040411RKB

Figure 1 HVPS PWB removal

#### Replacement

**NOTE:** Tapered Plastic Screws and Round Machine Screws are used to hold the PWB to the frame. Make sure that the Plastic Screws go into plastic components and Machine Screws go into the metal frame.

The replacement is the reverse of the removal procedure.

## REP 4.2 LVPS (Low Voltage Power Supply)

Parts List on [PL 4.1](#)

### Removal

#### WARNING

Do not perform repair activities with the power on or electrical power supplied to the machine. Some machine components contain dangerous electrical voltages that can result in electrical shock and possible serious injury.

**DANGER:** Ne pas effectuer de dépannage avec le contact principal activé ou avec l'alimentation électrique appliquée à la machine. Certains éléments de la machine comportent des tensions électriques dangereuses qui peuvent causer un choc électrique et de graves blessures.

**AVVERTENZA:** Non effettuare alcuna riparazione con l'alimentazione elettrica inserita. Alcuni componenti contengono corrente ad alta tensione che può provocare forti scosse e gravi ferite.

**VORSICHT:** Es dürfen erst Reparaturarbeiten durchgeführt werden, wenn das Gerät ausgeschaltet ist oder der Netzstecker nicht mehr mit der Stromquelle verbunden ist. Einige Komponenten des Gerätes sind stromführend und können daher zu ernsthaften Verletzungen oder Stromschlägen führen.

**AVISO:** No realice reparaciones con la máquina encendida o conectada a la corriente. Algunos componentes de la máquina contienen voltajes eléctricos peligrosos que pueden producir una descarga eléctrica y causar daños graves.

1. Switch off the printer, then disconnect the power cord.
2. Remove the Right Side Cover, [REP 2.2](#).

3. Remove the LVPS PWB, [Figure 1](#):
  - a. Disconnect two connectors.
  - b. Remove six screws, then remove the LVPS PWB.

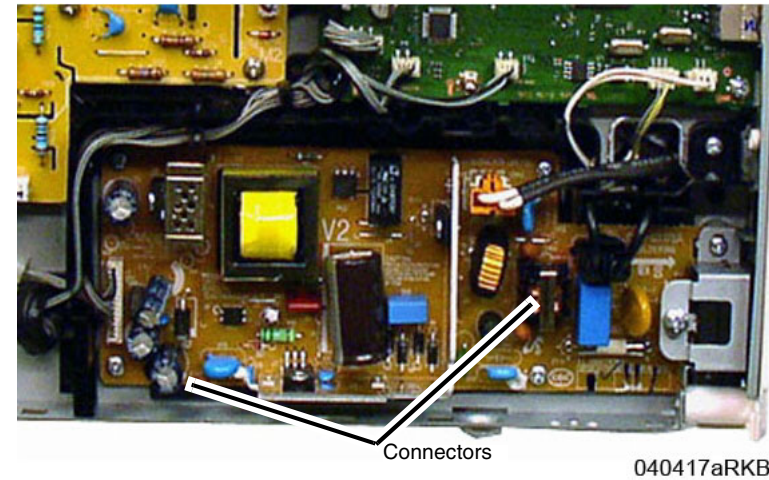

Figure 1 SMPS PWB removal

### Replacement

The replacement is the reverse of the removal procedure.



## REP 4.3 Feed and Registration Clutches / Paper Feed PWB

### Parts List on PL 4.1

#### Removal

1. Switch off the machine, then disconnect the power cord.
2. Remove the Left Side Cover, REP 2.2.
3. Removing the Joint PWB, Figure 1:
  - a. Disconnect the Connectors (3) on the Joint PWB.
  - b. Remove the Screw (1) and the PWB.
4. Removing the Feed Clutch, Figure 1:
  - a. Disconnect the Feeder Clutch Connector (CN2) on the Joint PWB and release the wires from the wire clamps.
  - b. Remove the E-ring and Washer from the Feeder Clutch.
  - c. Remove the Feeder Clutch.
5. Removing the Registration Clutch, Figure 1:
  - a. Disconnect the Registration Clutch Connector (CN1) on the Joint PWB and release the wires from the wire clamps.
  - b. Remove the E-ring and Washer from the Registration Clutch.
  - c. Remove the Registration Clutch.

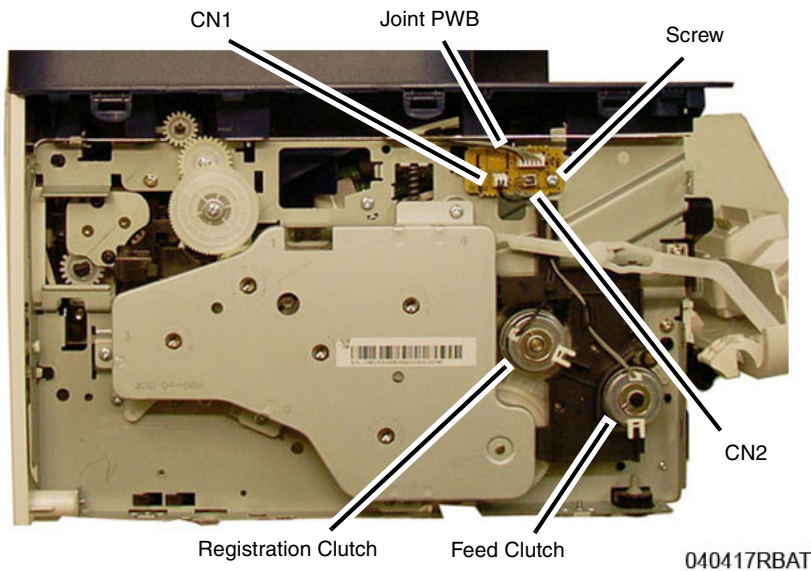

Figure 1 Feed and Registration Clutches / Joint PWB

#### Replacement

The replacement is the reverse of the removal procedure.

## REP 4.4 Transfer Roll

### Parts List on PL 4.1

#### Removal

1. Switch off the printer, then disconnect the power cord.
2. Open the Front Cover.

**NOTE:** Cover the Drum Cartridge with several sheets of paper to prevent it from being light shocked.

3. Remove the Toner Cartridge and the Drum Cartridge.
4. Remove (squeeze and lift) the Transfer Roll Retainer Clip, Figure 1.

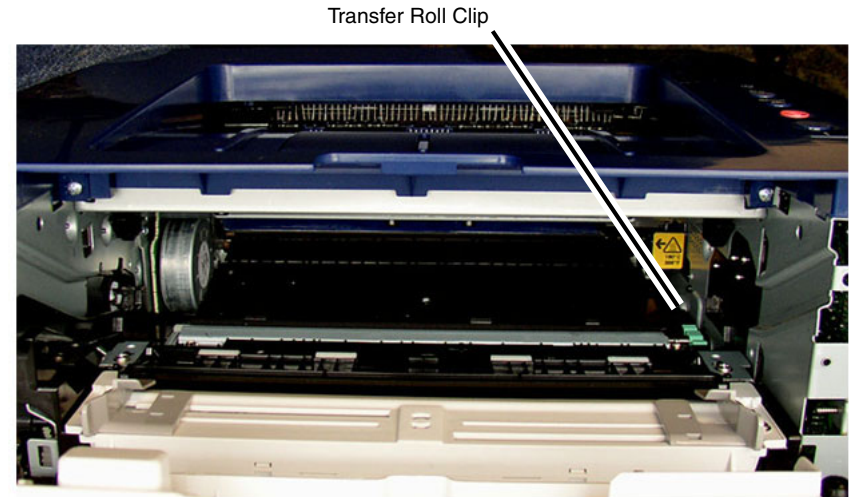
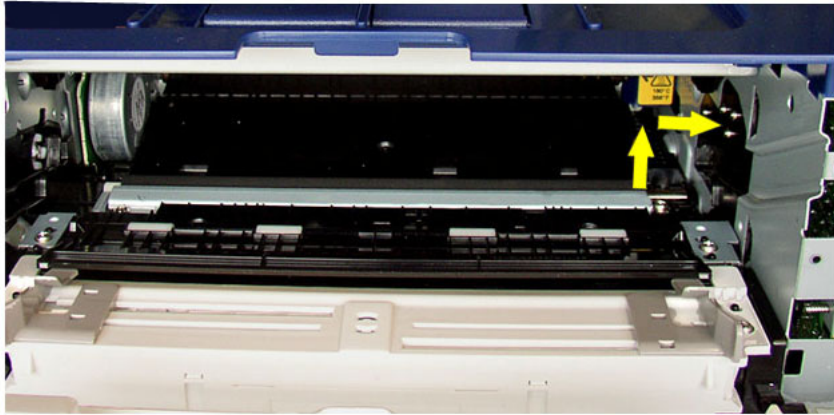

Figure 1 Transfer Roll Retainer Clip (Front View)

5. Remove the Transfer Roll, [Figure 2](#):
  - a. Lift the right end of the Transfer Roll and slide the left end out of the bushing.



040422RKB

Figure 2 Removing the Transfer Roll

### Replacement

The replacement is the reverse of the removal procedure.

## REP 4.5 LSU and Cables

### Parts List on [PL 4.1](#)

#### Removal

1. Switch off the printer, then disconnect the power cord.
2. Remove the Middle Cover, [REP 2.5](#).
3. To replace the LSU Cables, [Figure 1](#):
  - Disconnect two connectors at the LSU.
  - Disconnect the connector at the Main PWB.

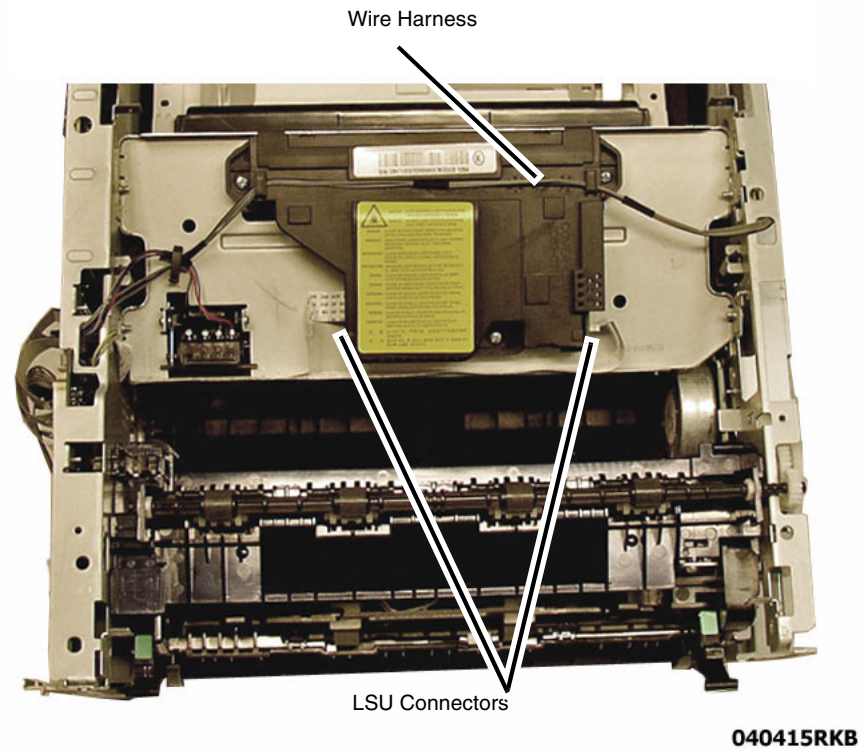

040415RKB

Figure 1 LSU Cable Connectors and Wire Harness (Top View)

**NOTE:** The Flat Cable may be adhered to the LSU. Detach it from the LSU and reinstall it on the new LUS in the same location.

4. Removing the LSU, [Figure 2](#):
  - a. Release the wire harness from the top of the LSU, then disconnect two connectors at the LSU.
  - b. Remove three screws, then remove the LSU.

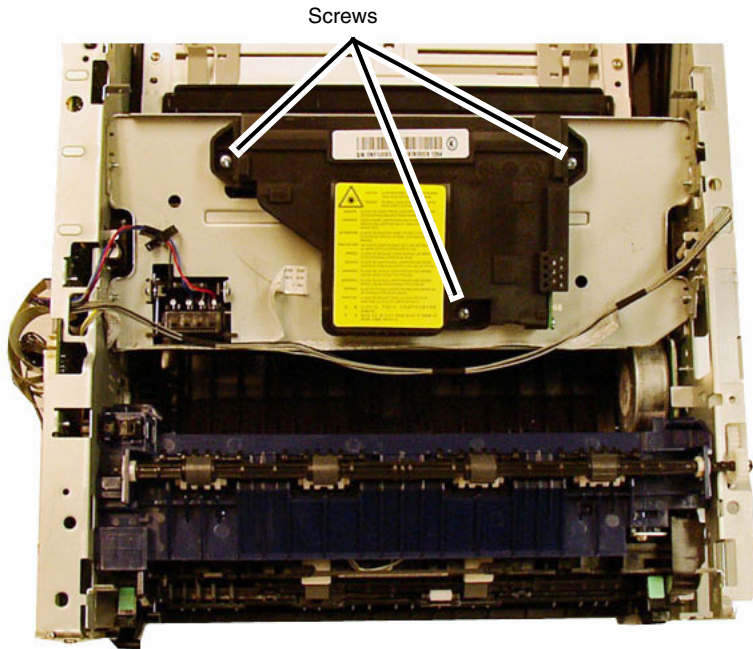

040416RKB

Figure 2 LSU Removal

### Replacement

The replacement is the reverse of the removal procedure.

## REP 4.6 Duplex

### Parts List on [PL 4.2](#)

#### Removal

1. Switch off the printer, then disconnect the power cord.
2. Remove the Paper Tray, [PL 6.1 Item 18](#).
3. Remove the Left and Right Side Covers, [REP 2.2](#).
4. Remove the Rear Cover, [REP 2.3](#).

**NOTE:** The Rear Cover retains the pivot in the rear left frame notch when the front latches are released.

5. Press two green buttons to release two tabs locking the Duplex, [Figure 1](#).

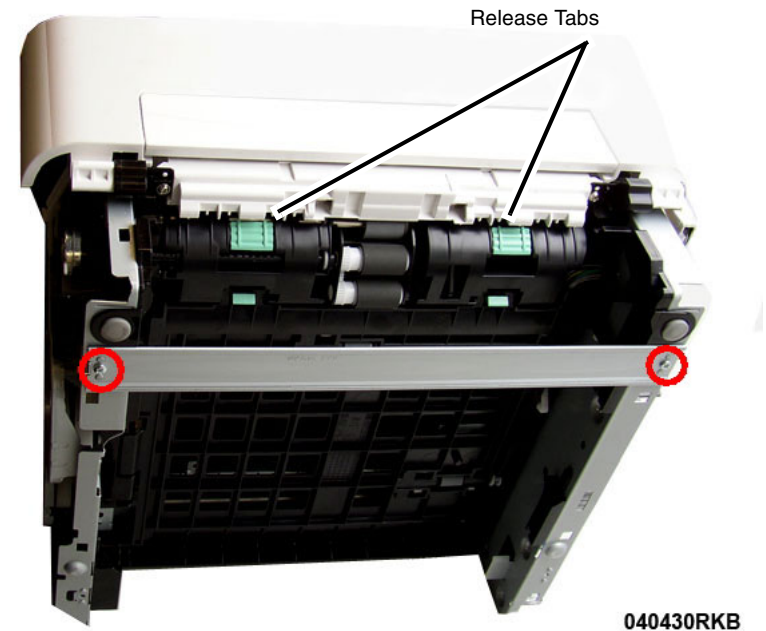

040430RKB

Figure 1 Duplex Paper Guide Release Tabs (Bottom View)

6. From the rear of the printer, slide the pivot out of the pivot cutout in the frame, slide the pivot out of the hole in the opposite frame, then remove the Duplex, [Figure 2](#).



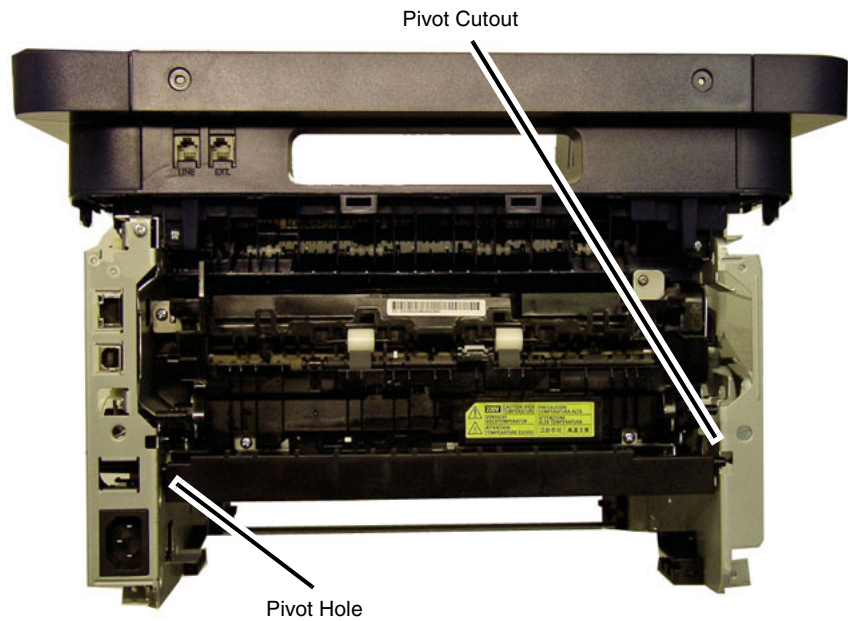

040426RBAT

Figure 2 Duplex Paper Guide Pivots (Rear View)

### Replacement

The replacement is the reverse of the removal procedure.

## REP 4.7 Output Tray Full Sensor

Parts List on [PL 4.3](#)

### Removal

1. Switch off the machine, then disconnect the power cord.
2. Remove the Middle Cover, [REP 2.5](#).

**NOTE:** Do not disconnect the connectors to the Main PWB. The PWB only needs to be moved away from the frame to access the Output Tray Full Sensor.

**NOTE:** Mark the location of the Ground Screw, with larger head, so it can be re-installed in the correct location.

3. Remove five screws, then move the Main PWB away from the printer frame, [Figure 1](#).

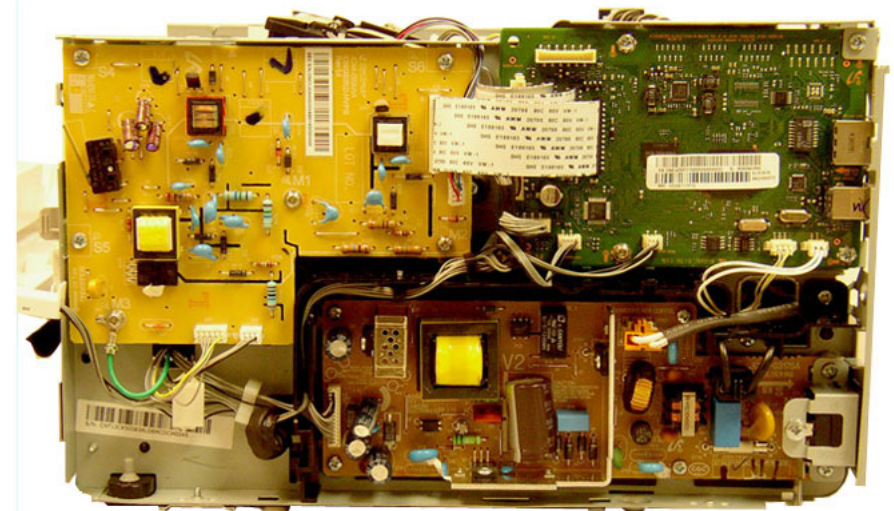

040407RKB

Figure 1 Main PWB

4. Remove the Output Tray Full Sensor, [Figure 2](#):
  - a. Disconnect the Sensor connector.
  - b. Unlatch and remove the Output Tray Sensor.

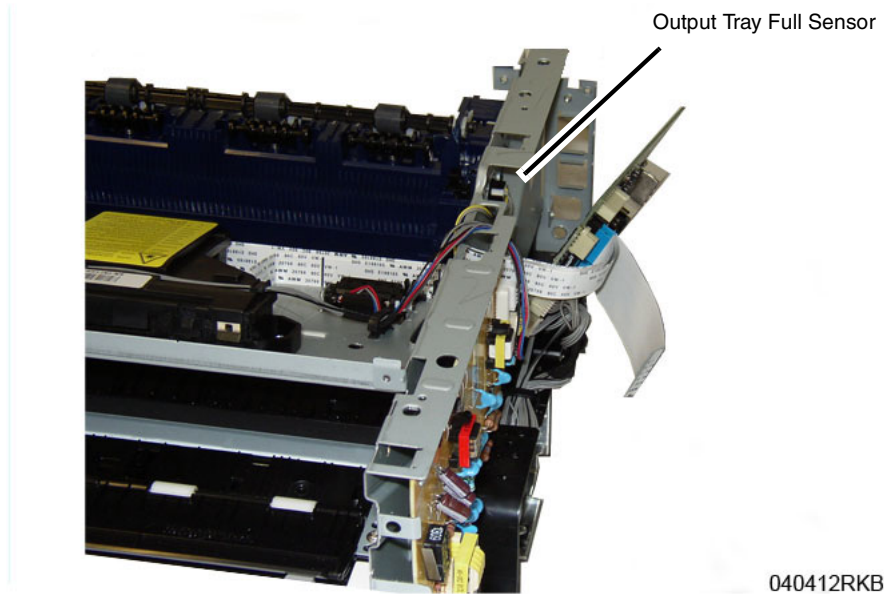

Figure 2 Output Tray Full Sensor (Top Right View)

### Replacement

**NOTE:** Tapered Plastic Screws and Round Machine Screws are used to hold the Fuser to the frame. Make sure that the Plastic Screws go into plastic components and Machine Screws go into the metal frame.

The replacement is the reverse of the removal procedure.

## REP 4.8 Exit Roll and Bushings

### Parts List on [PL 4.3](#)

#### Removal

1. Switch off the printer, then disconnect the power cord.
2. Remove the Middle Cover, [REP 2.5](#).
3. Remove the Exit Roll and Bushings, [Figure 1](#).
  - a. Remove the Drive Gear, then release the latch.
  - b. Remove two Bushings, then release the latch and rotate the bushing.
  - c. Remove the Exit Roll.

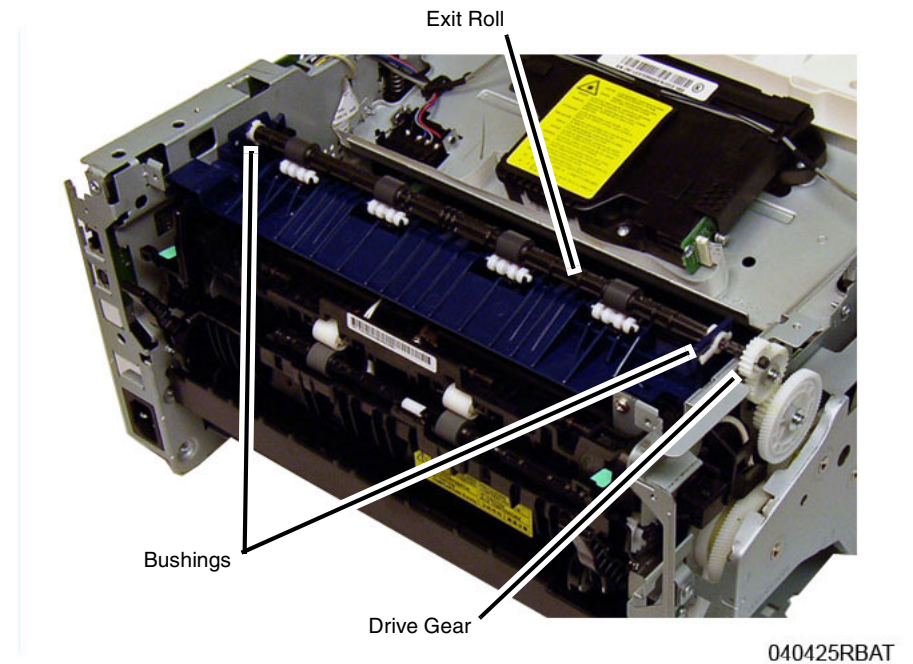

Figure 1 Exit Roll and Bushing (Top View)

### Replacement

The replacement is the reverse of the removal procedure.



## REP 4.9 Registration Roll

Parts List on [PL 4.4](#)

### Removal

1. Switch off the printer, then disconnect the power cord.
2. Remove the Left and Right Side Covers, [REP 2.2](#).
3. Remove the Front Cover, [REP 2.1](#).
4. Remove the Rear Cover, [REP 2.3](#).
5. Remove the Middle Cover, [REP 2.5](#).
6. Remove two screws, then remove the bottom bar, [Figure 1](#).

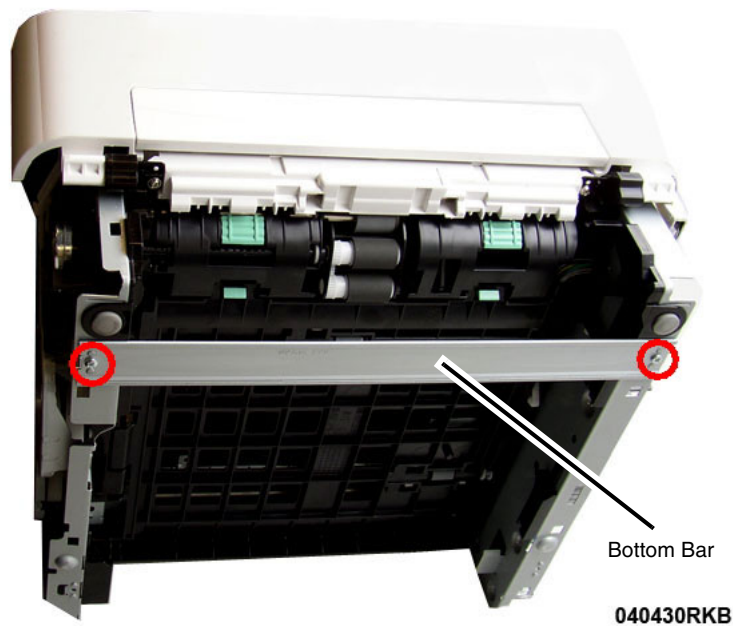

Figure 1 Bottom Bar and Duplex Paper Guide (Bottom View)

7. Remove the Duplex, [REP 4.6](#).
8. Remove the Fuser, [PL 5.1 Item 26](#).

9. Remove five screws attaching the Main Drive Unit, then move the Fuser Drive Locking Lever to the unlock position (clockwise), [Figure 2](#).

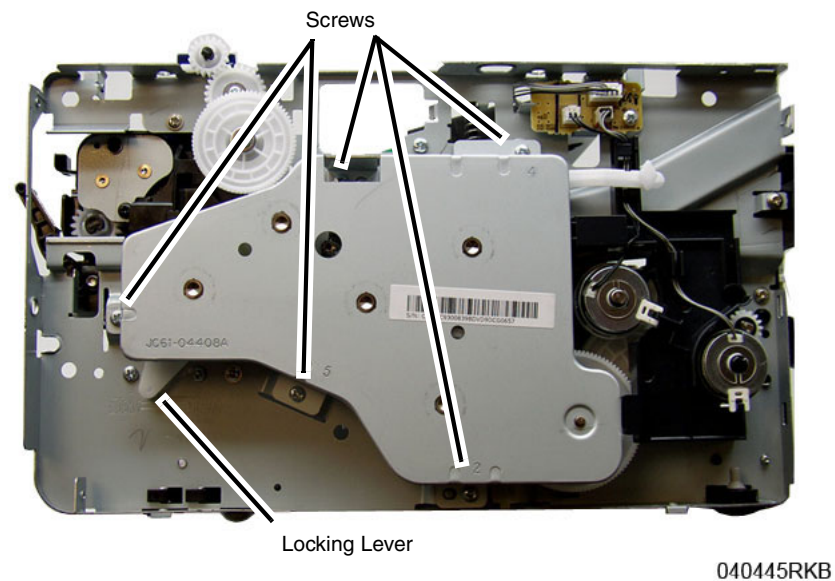
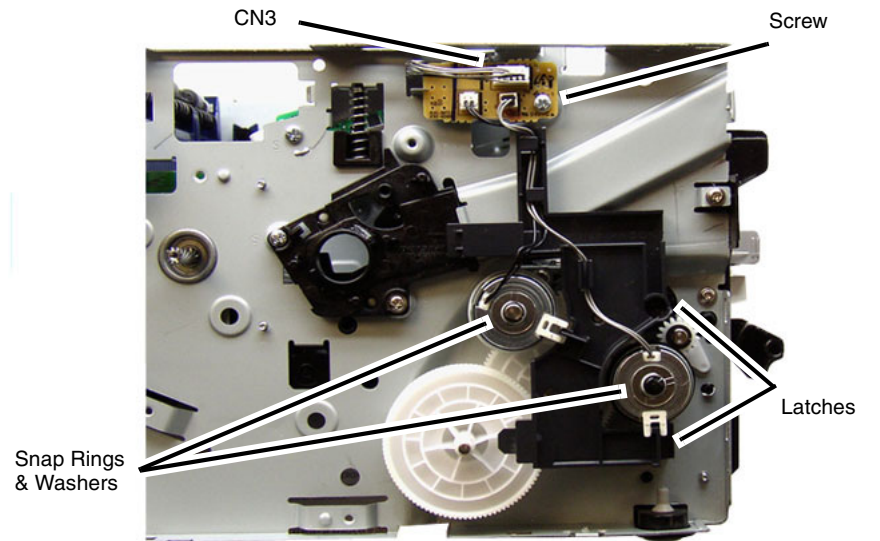

Figure 2 Main Drive Unit

10. Remove the following in order, **Figure 3**:
- Disconnect CN3, remove the screw, then remove the Feeder PWB.
  - Remove the snap rings and washers from the Clutches, then remove the Feed and Registration Clutches.
  - Release two latches, then remove the Feed and Registration Clutch Assembly.



040446RKB

**Figure 3 Feed and Registration Clutch / Feeder PWB**

11. Remove the Feed and Registration Clutch Drive Gears, **Figure 4**.

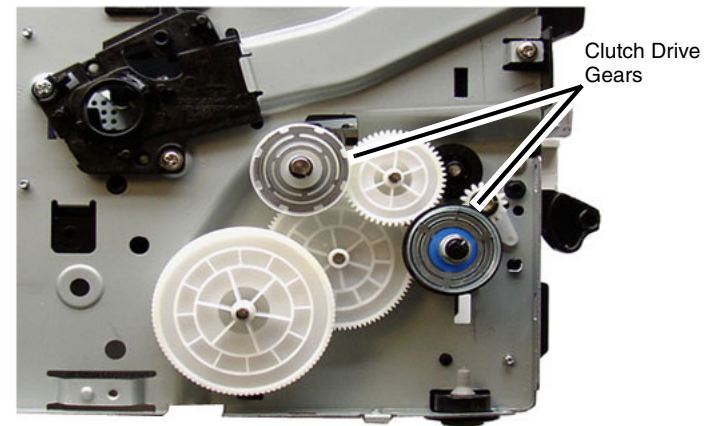

040447RKB

**Figure 4 Feed and Registration Clutch Drive Gears**

12. Remove the Drive Gears and Bushings, [Figure 5](#):

**CAUTION**

*Note the order of the Feed and Registration Drive Gears as removed for correct installation.*

- a. Remove the snap ring, then remove the Feed and Registration Drive Gears.
- b. Remove two snap rings, then remove the Feed and Registration Clutch Bushings.
- c. Release two latches, then remove the Shaft Bushings.

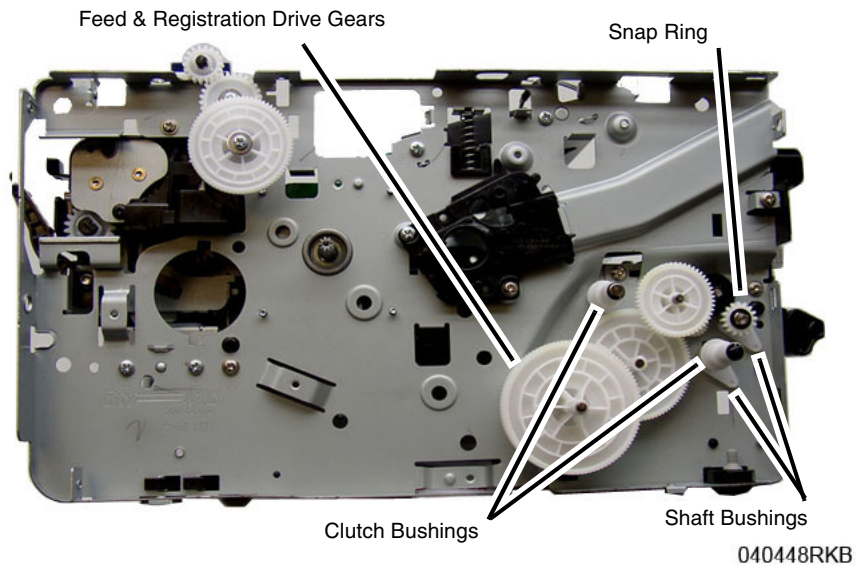

**Figure 5 Drive Gears and Bushings**

13. Remove the Feed and Registration Sensor PWB Cover, [Figure 6](#):

- a. Remove the screw.
- b. Release the latch, then remove the cover.

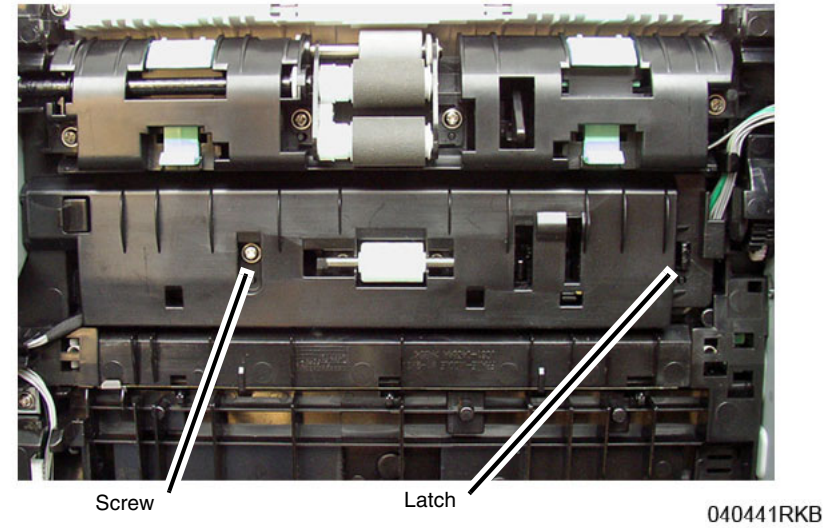

**Figure 6 Feed and Reg Sensors PWB Cover (Bottom View)**

14. Unlatch the Feed Sensor Actuator, then remove the Feed Sensor Actuator, **Figure 7**.

**NOTE:** Note the location of the spring in the frame cutout for reinstallation.

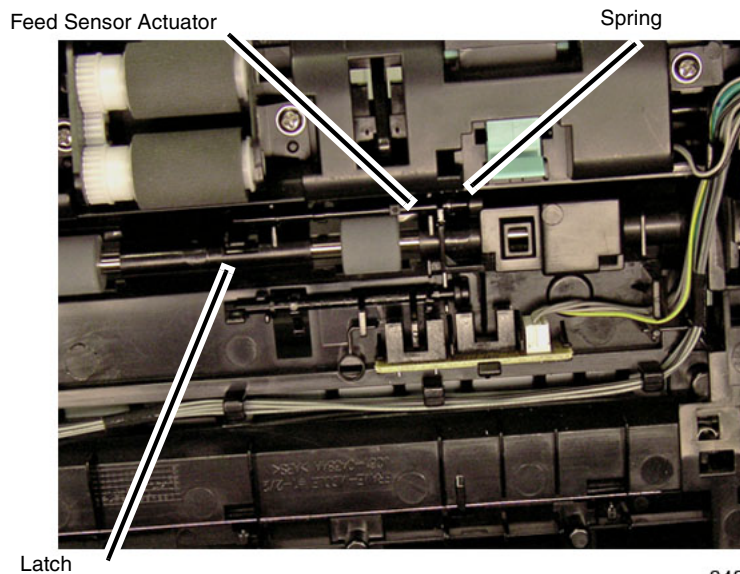

**Figure 7 Feed Sensor Actuator (Bottom View)**

040442RKB

15. Remove the ground screw, then disconnect the Drive Motor, **Figure 8**.

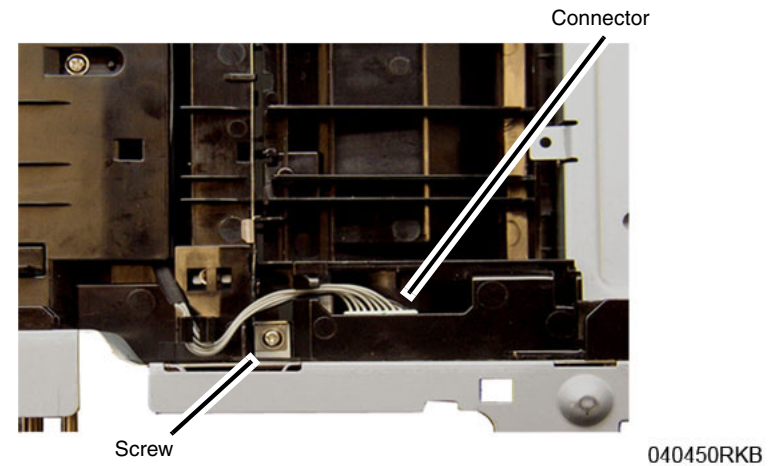
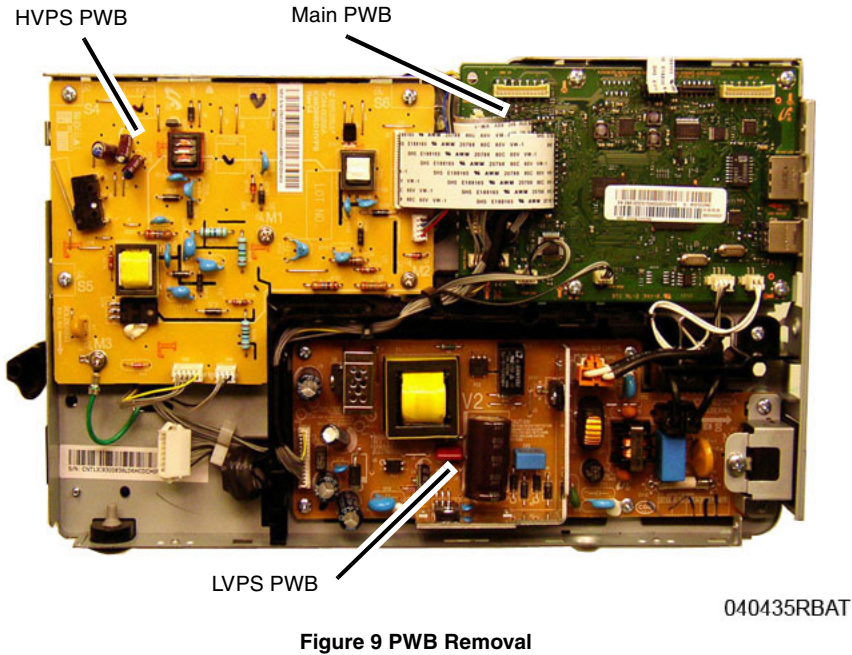

**Figure 8 Drive Motor Connector & Screw (Bottom View)**

040450RKB



16. Remove the PWBs, **Figure 9**:
  - a. Disconnect the connectors, the ground wire, and the FFC cable on the HVPS PWB.
  - b. Remove six screws attaching the HVPS PWB.
  - c. Remove the four spring contacts from the high voltage contact guide.
  - d. Disconnect the connectors, remove six screws attaching the LVPS PWB, Remove the LVPS PWB, then remove the insulation pad behind the LVPS PWB.
  - e. Remove six screws attaching the LVPS PWB, then remove the insulation pad behind the LVPS PWB.
  - f. Disconnect the connectors, remove five screws attaching the Main PWB, then remove the Main PWB.



17. Remove two screws on the left-side, **Figure 10**, two screws on the right-side, **Figure 11**, then remove the LSU Assembly.

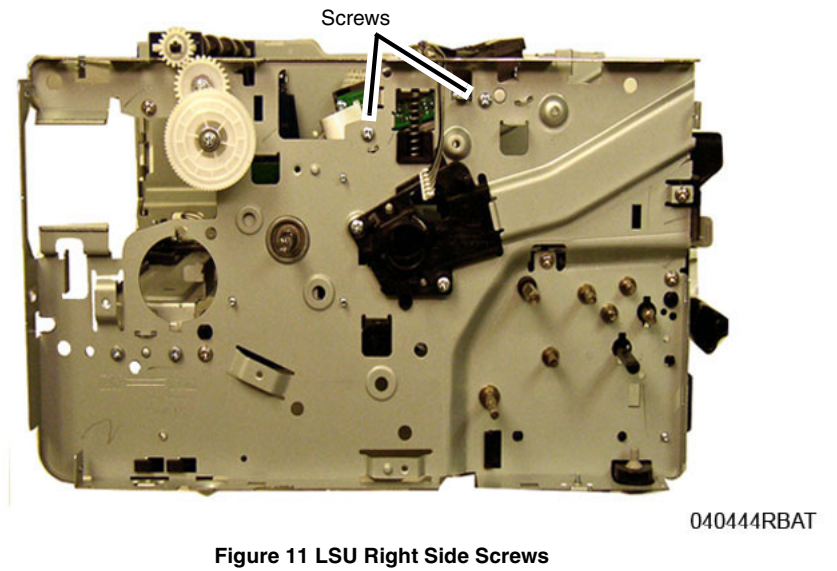
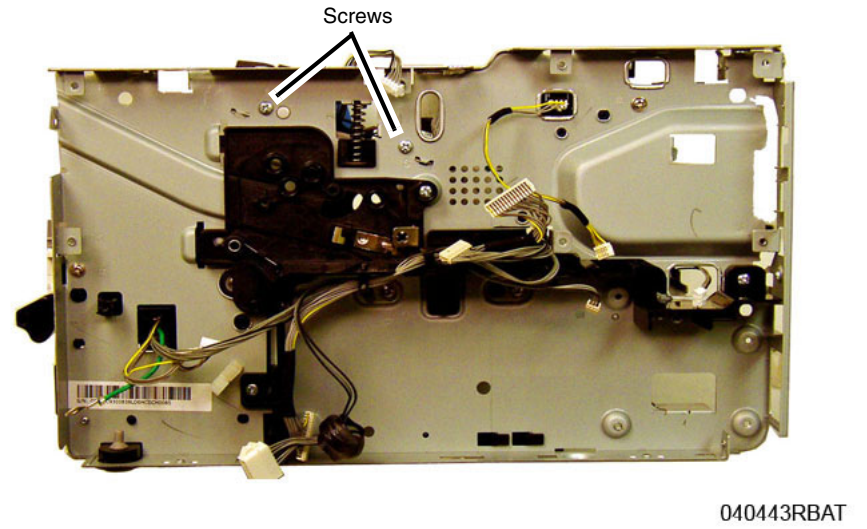

18. Remove two screws attaching the wire harness guide, two screws attaching the high voltage contact guide, then remove the guides, [Figure 12](#).

19. Remove two screws attaching the Exit Sensor Plate, [Figure 13](#).

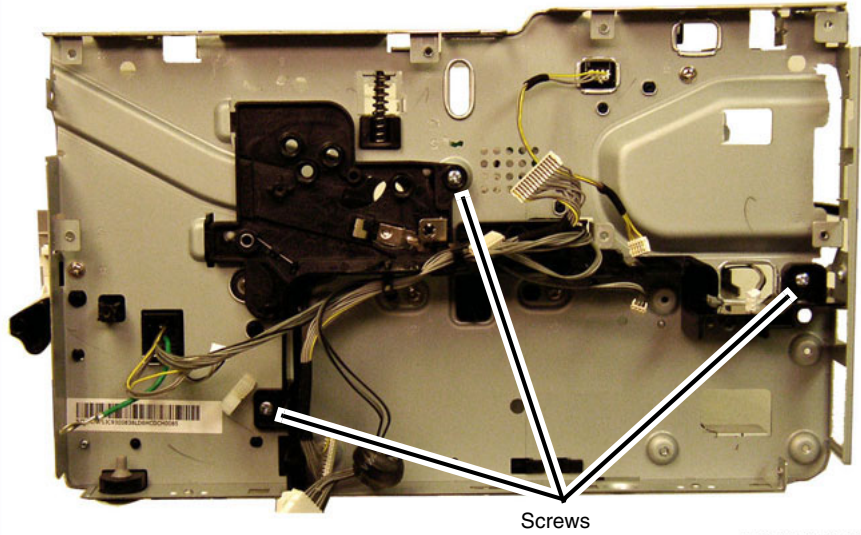

040445RBAT

Figure 12 Wire Guides and HV Contact Guide

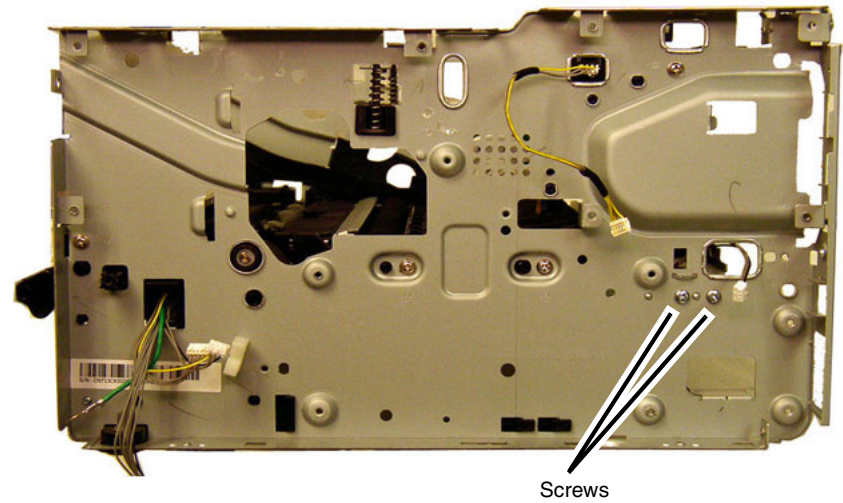

040446RBAT

Figure 13 Exit Sensor Plate Screws



20. Remove three screws attaching the Middle Frame, the two screws attaching the Exit Frame to the Right Main Frame, [Figure 14](#).

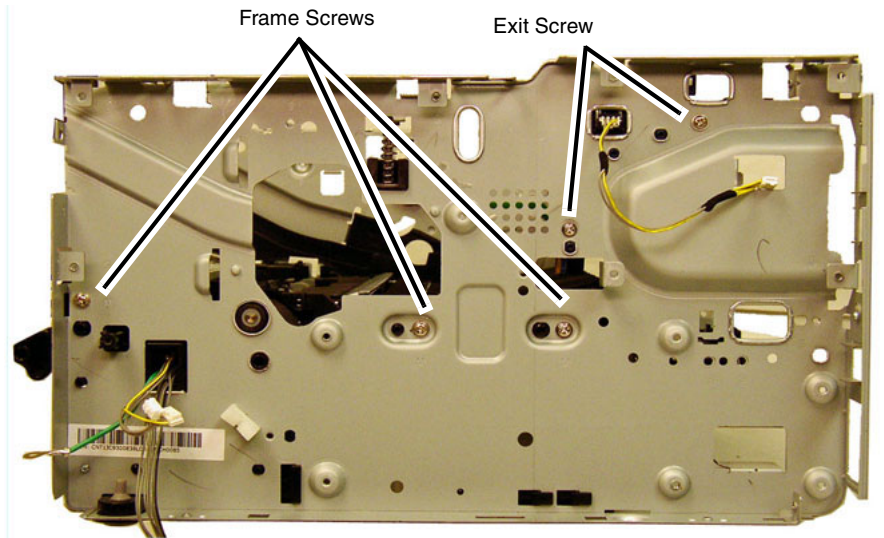

040447RBAT

Figure 14 Right Frame screws removal

21. Remove three screws attaching the Middle Frame, [Figure 15](#).

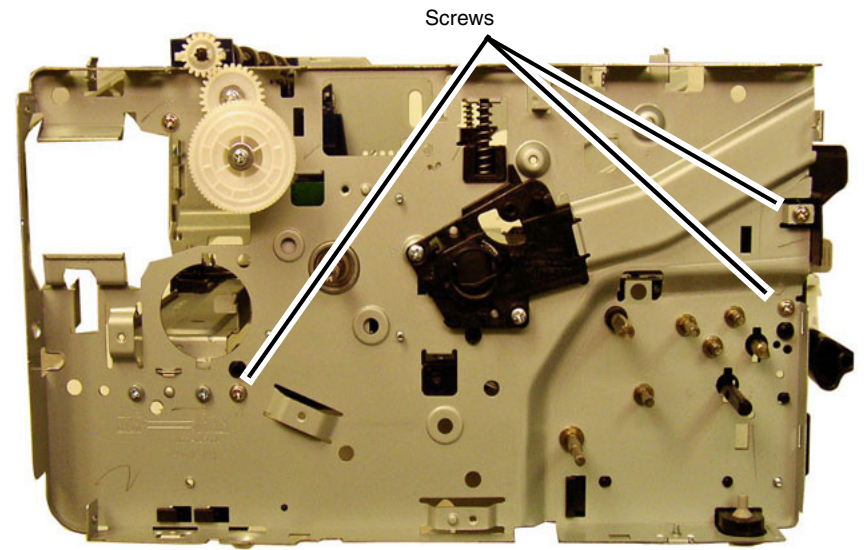

040448RBAT

Figure 15 Left Frame Screw Removal

22. Remove the Left and Right Frames from the Middle Frame routing the wires through the frames as needed.
23. Remove the following items, [Figure 16](#):
- Registration Roll Pivot Gear, [PL 4.1 Item 25](#).
  - Registration Roll Drive Gear, [PL 4.1 Item 26](#).
  - Pivot Plate, [PL 4.1 Item 27](#).
  - Collar, [PL 4.1 Item 28](#).

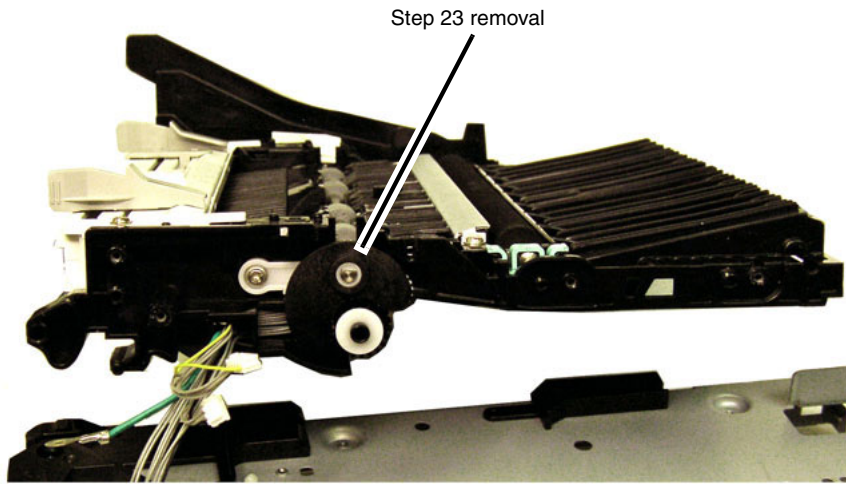

040449RBAT

Figure 16 Registration pivot items removal

24. Remove the screw attaching the Registration Holder, [PL 4.4 Item 16](#), then remove the Registration Holder, [Figure 17](#).

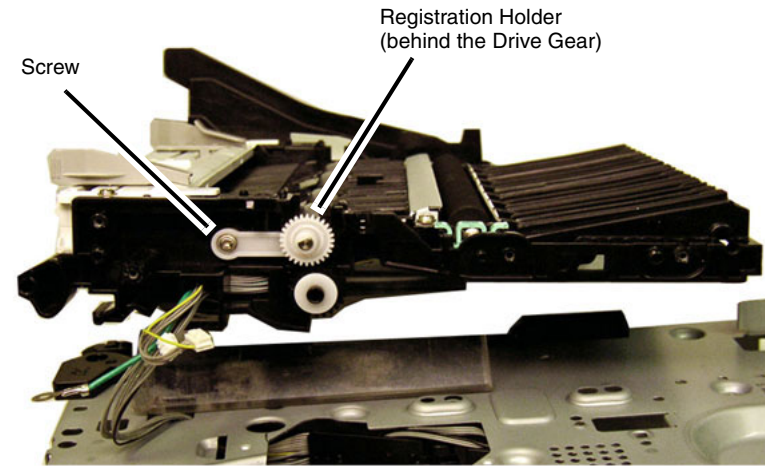

040450RBAT

Figure 17 Registration holder removal



25. Remove the Registration Roll from the Paper Path Frame, [Figure 18](#).

**NOTE:** Note the location of the bushing in the frame for reinstallation.

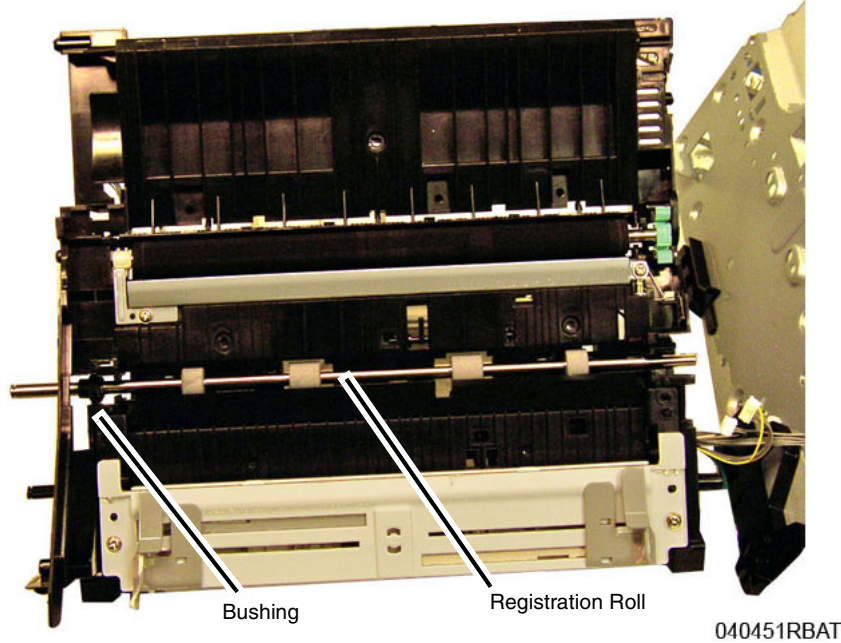

Figure 18 Registration Roll Removal

26. Remove the bushing and e-ring from the Registration Roll, [Figure 19](#).

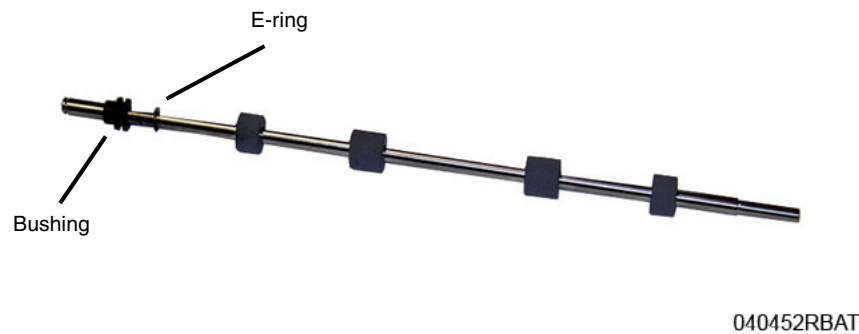

Figure 19 Registration Roll

## Replacement

**NOTE:** Tapered plastic screws and round machine screws are used to hold the parts to the frame. Make sure that the plastic screws go into plastic components and machine screws go into the metal frame.

The replacement is the reverse of the removal procedure.

**NOTE:** The frame is flexible and can be bowed out if the screws are not tightened in the correct order. Reinstall the frame as follows so it seats flush against the printer's internal modules.

1. After aligning the left and right frames together with the inside modules; install, but do not tighten, the three Paper Path Frame screws on the Right, [Figure 14](#), and three Left, [Figure 15](#).
2. On the bottom of the printer, refer to, [Figure 8](#):
  - a. Install the ground screw.
  - b. Connect the Printer Drive Motor Connector.
3. Tighten the Paper Path Frame screws installed in Step 1.
4. Continue with the parts replacement:
  - a. When installing the Paper Feed Sensor Actuator make sure the spring is seated in the frame cutout, refer to, [Figure 7](#).
  - b. Refer to, [Figure 20](#), for installation of the Feed and Registration Drive Gears and Snap Ring.

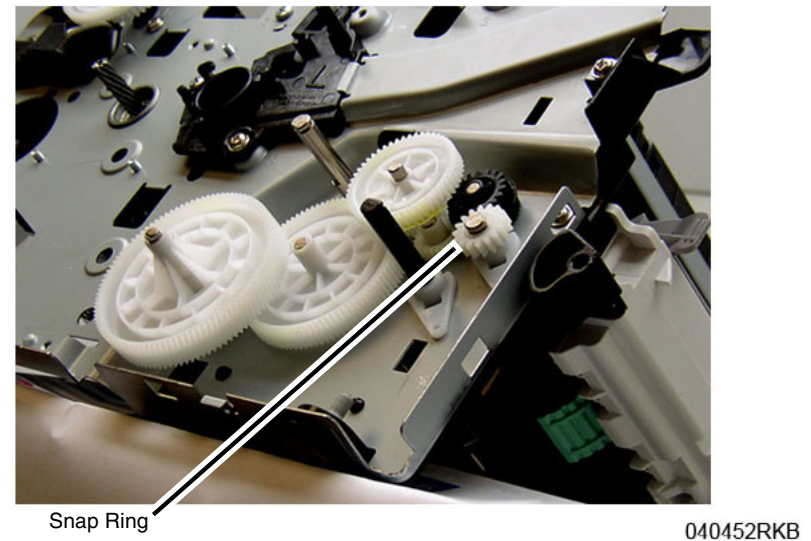
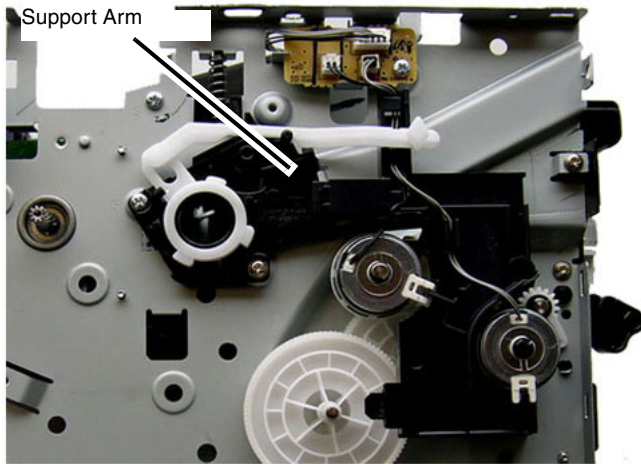

Figure 20 Feed and Registration Drive Gears

- c. Front Cover Support Arm placed correctly on the Stop Bracket, [Figure 21](#).



040443RKB  
**Figure 21 Front Cover Support Arm Placement**

## REP 4.10 Paper Feed Sensors PWB and Actuators

### Parts List on [PL 4.4](#)

#### Removal

1. Switch off the printer, then disconnect the power cord.
2. Remove the Duplex, [REP 4.3](#).
3. Set the printer on the Rear Cover (Front of printer facing up).
4. Remove two screws, then remove the Bottom Bar, [Figure 1](#).

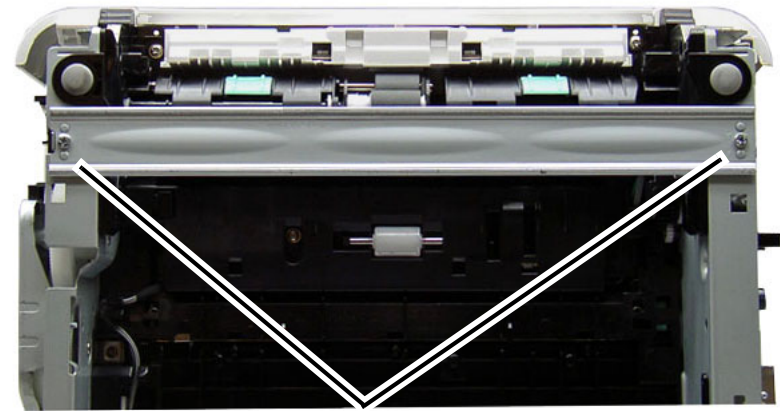

Screws

040436RKB

**Figure 1 Bottom Bar (Bottom View)**

5. Remove the Paper Feed Sensor PWB Cover, [Figure 2](#).

- a. Remove the screw.
- b. Release the latch and remove the cover.

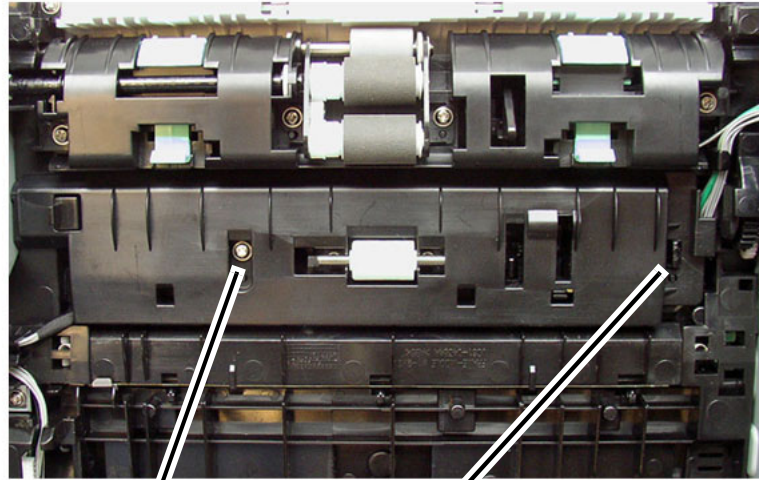

Screw

Latch

040441RKB

**Figure 2 Feed Sensors PWB Cover (Bottom View)**

6. Release the latch and remove the Feed Sensor PWB, [Figure 3](#).

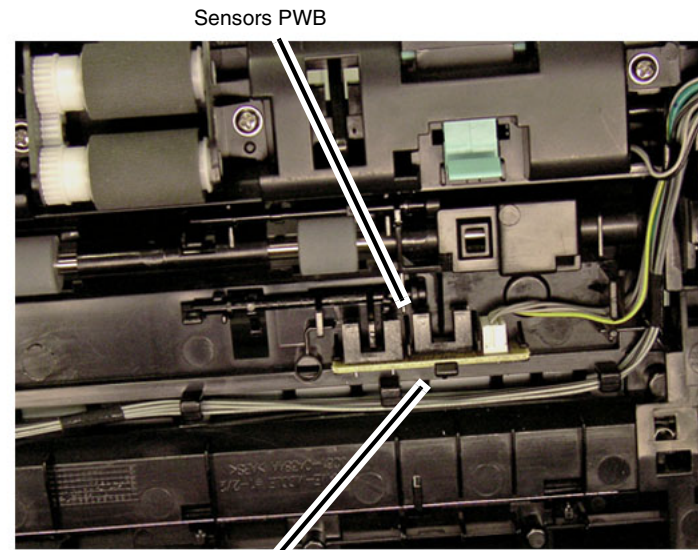

Sensors PWB

Latch

040442RKB

**Figure 3 Feed Sensor PWB (Bottom View)**



7. Remove the Feed and Registration Sensor Actuators, [Figure 4](#):  
Note the location of the Spring in the frame cutout for reinstallation.
  - a. Release the Actuator from the latch.
  - b. Remove the Actuator.

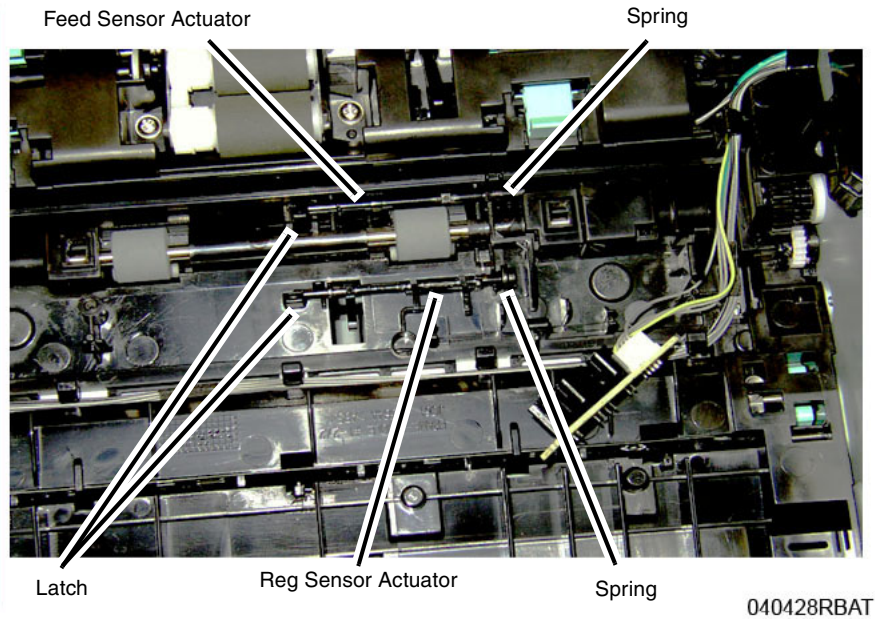

Figure 4 Feed and Registration Sensors Actuators (Bottom View)

040428RBAT

## Replacement

**NOTE:** Tapered plastic screws and round machine screws are used to hold the cover to the frame. Make sure that the plastic screws go into plastic components and machine screws go into the metal frame.

The replacement is the reverse of the removal procedure.

**NOTE:** When replacing the Actuators make sure the Spring is correctly seated in the cutout in the frame, [Figure 5](#).

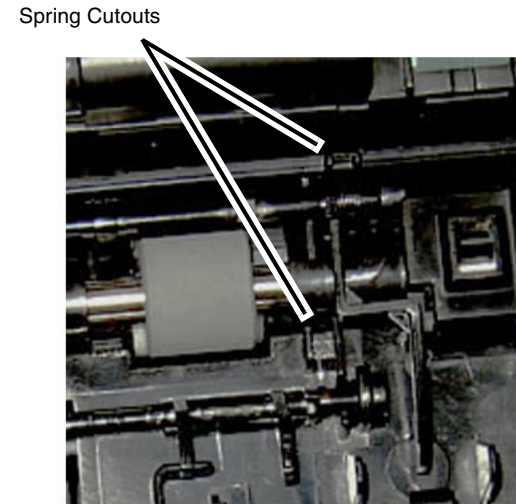

Figure 5 Actuator Spring Cutouts (Bottom View)

040428aRBAT

## REP 4.11 Manual Paper Tray

Parts List on [PL 4.4](#)

### Removal

1. Switch off the printer, then disconnect the power cord.
2. Remove the Middle Cover, [REP 2.5](#).
3. Remove two screws at the bottom of the Manual Paper Tray, [Figure 1](#).

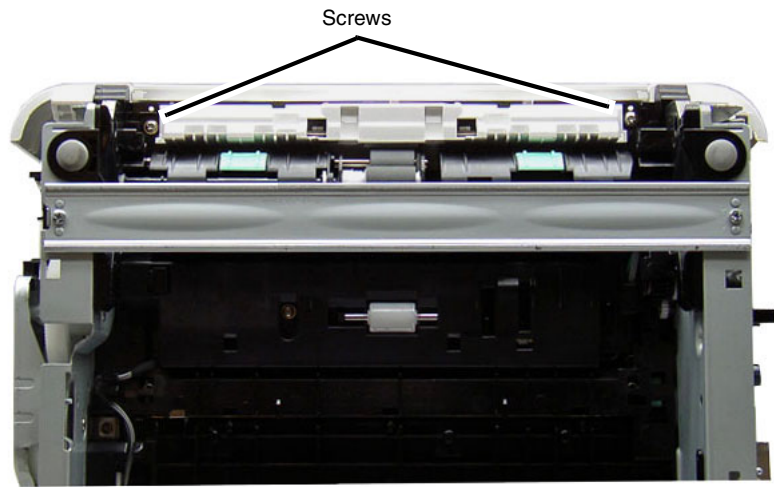

040436RKB

Figure 1 Manual Paper Tray Bottom Screws (Bottom View)

4. Remove two screws from the top of the Manual Paper Tray, then remove the Manual Paper Tray, [Figure 2](#).

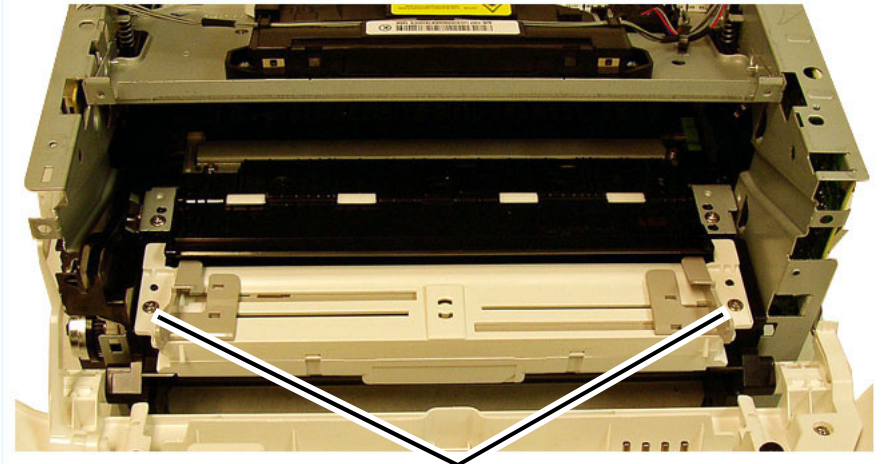

040437RBAT

Figure 2 Manual Paper Tray Top Screws (Top View)

### Replacement

The replacement is the reverse of the removal procedure.

## REP 4.12 Exit Sensor

### Parts List on PL 4.5

#### Removal

1. Remove the following covers:
  - a. Remove the Left and Right Side Covers, REP 2.2.
  - b. Remove the Rear Cover, REP 2.3.
2. Remove the Fuser Module.
3. Press the latch on the underside of the frame to release the Exit Sensor Mounting Plate from the frame, Figure 1.

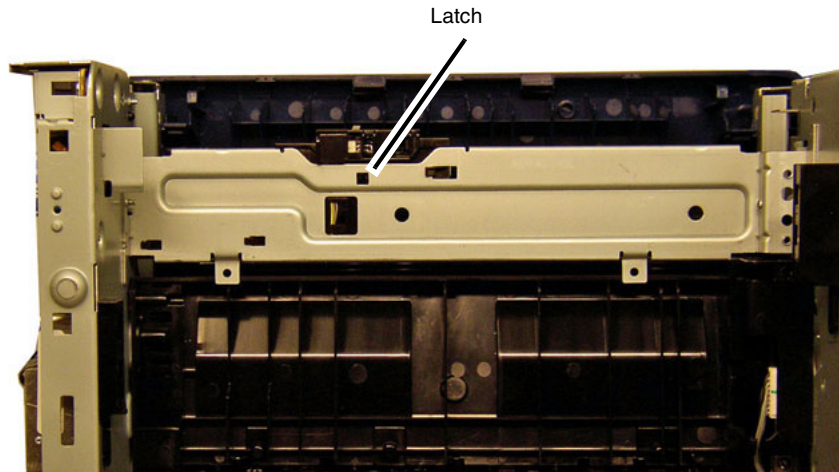

040426RKB

Figure 1 Exit Sensor Plate Latch Release (Bottom View)

4. Remove the Exit Sensor, Figure 2:
  - a. Release the wires from the cable clamps.
  - b. Unlatch the Exit Sensor, remove the Exit Sensor, then disconnect the connector.

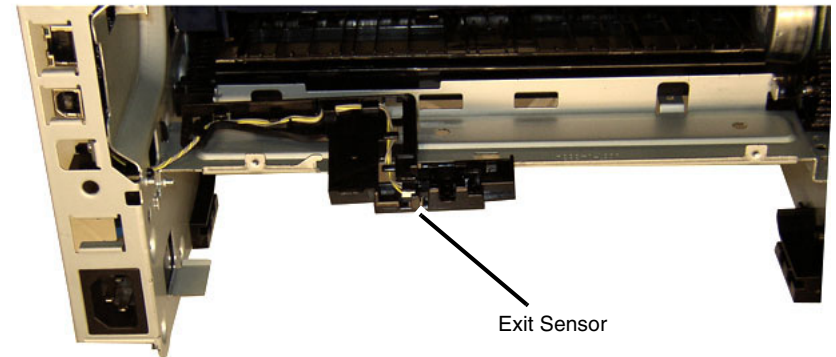

040427RKB

Figure 2 Exit Sensor Removal (Rear View)

#### Replacement

The replacement is the reverse of the removal procedure.

## REP 4.13 Paper Drive Roll

### Parts List on PL 4.5

#### Removal

1. Switch off the printer, then disconnect the power cord.
2. Remove the following covers:
  - a. The Front Cover, REP 2.1.
  - b. The Middle Cover, REP 2.5.
3. Disconnect connector CN6 from the HVPS PWB, and route the wires through the frame, Figure 1.

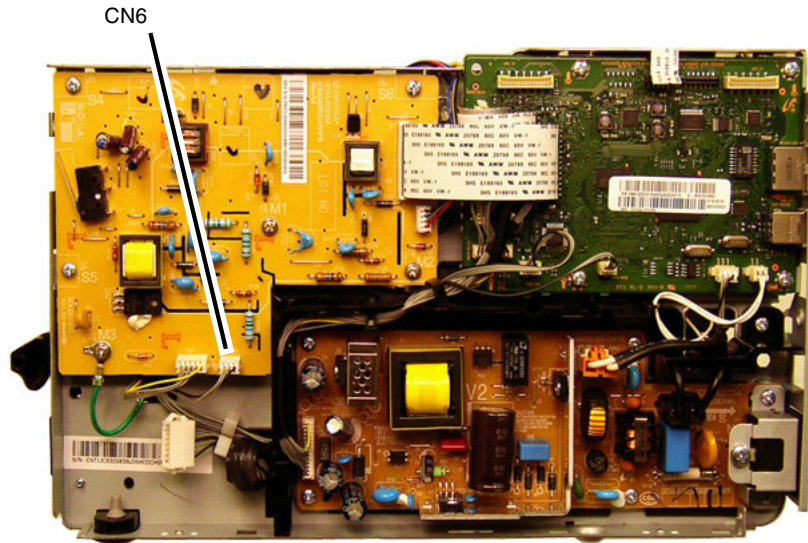
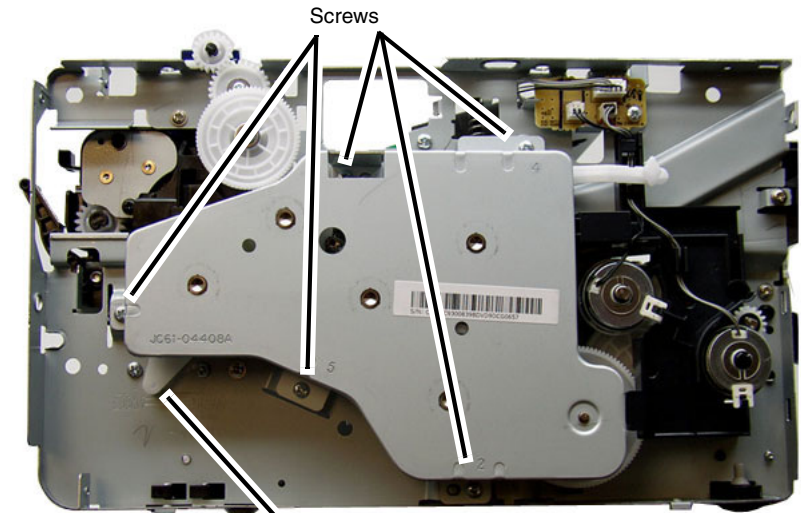

Figure 1 HVPS CN6

040435RBAT

4. Remove five screws attaching the Main Drive Unit, move the Fuser Drive Locking Lever (right) to the unlock position, then remove the Main Drive Unit, Figure 2.



Locking Lever

Figure 2 Main Drive Unit

040445RKB



5. Remove the Feed and Registration Clutch Assembly and the PWB, **Figure 3**:
  - a. Disconnect CN3 from the Joint PWB, then remove the screw.
  - b. Remove the snap rings and washers from the Clutches, then remove the Feed and Registration Clutches.
  - c. Release two latches, then remove the Feed and Registration Clutch Assembly and the PWB.

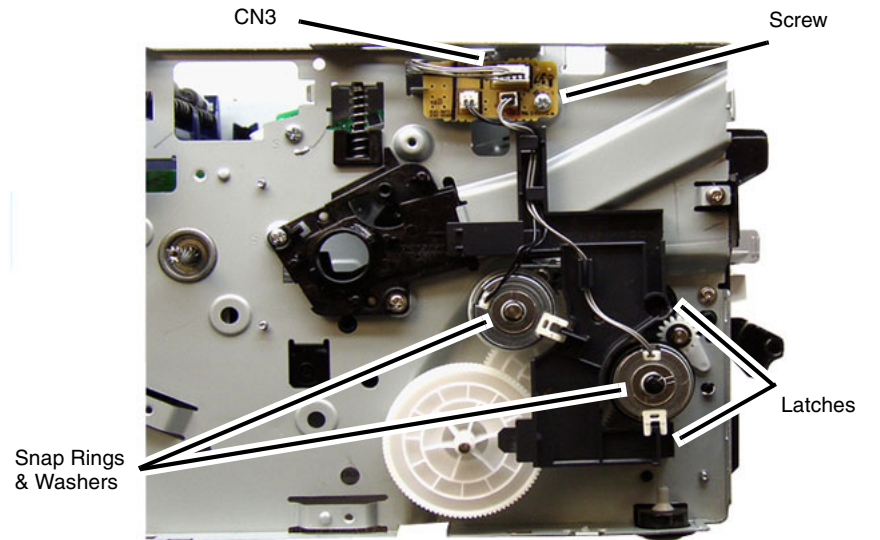

040446RKB

**Figure 3 Feed and Registration Clutch / Feeder PWB**

6. Remove the Feed and Registration Clutch Drive Gears, **Figure 4**.

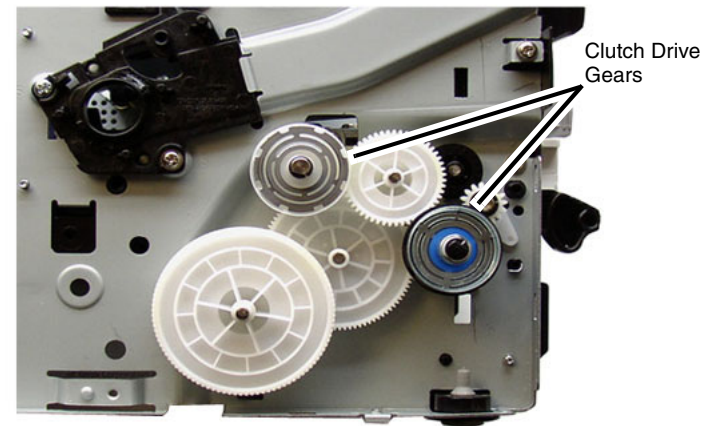

040447RKB

**Figure 4 Feed and Registration Clutch Drive Gears**



7. Remove the following parts, [Figure 5](#):
  - a. Remove the Drive Gears.
  - b. Remove the snap ring, then remove the Feed Clutch Bushing.
  - c. Release the latch and rotate the bushing, then remove the Feed Shaft Bushings.
  - d. Remove the screw of the Feed Assembly.

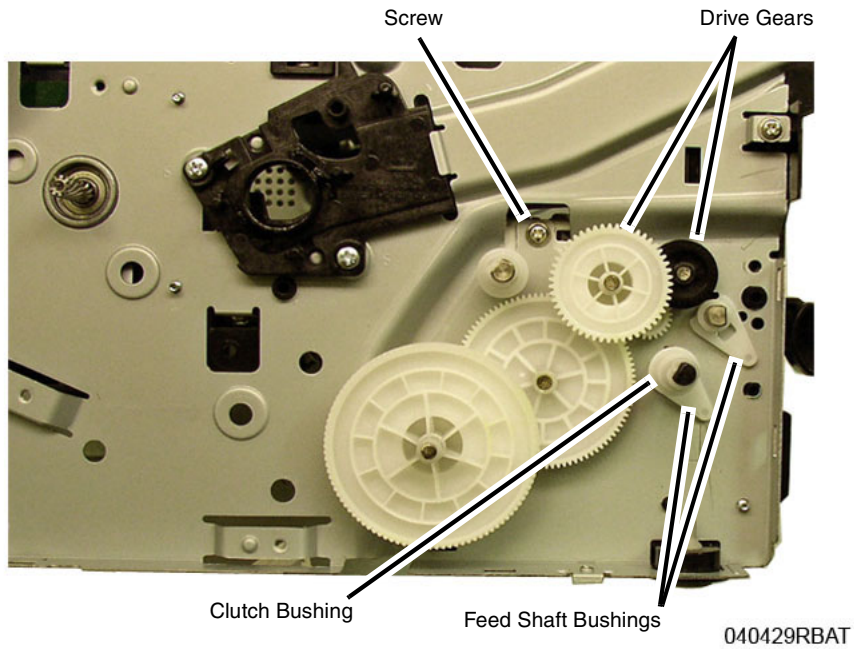

**Figure 5 Feeder Drives**

040429RBAT

8. Remove two screws from the bottom of the Feed Assembly, [Figure 6](#).

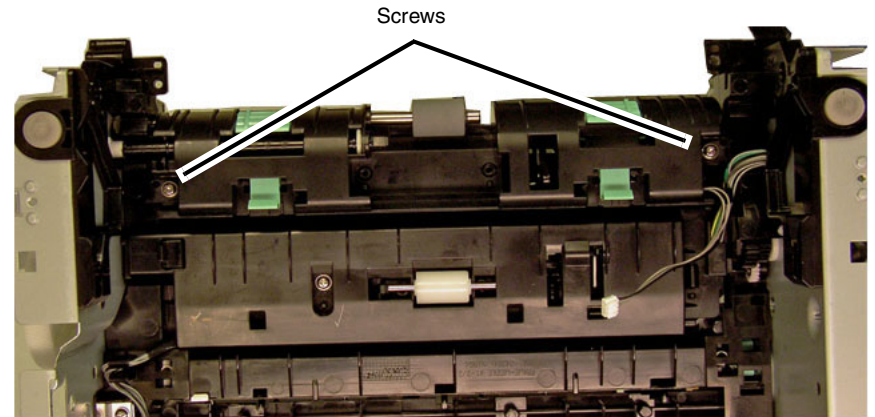

040430RBAT

**Figure 6 Feeder Assembly Bottom Screws (Bottom View)**

**CAUTION**

*The brackets holding the registration pinch rolls and guide are spring loaded. Maintain light pressure on the brackets when removing them to avoid damaging parts or personal injury.*

9. Remove two screws, then remove the Registration Pinch Rolls and Paper Guide Brackets, [Figure 7](#).

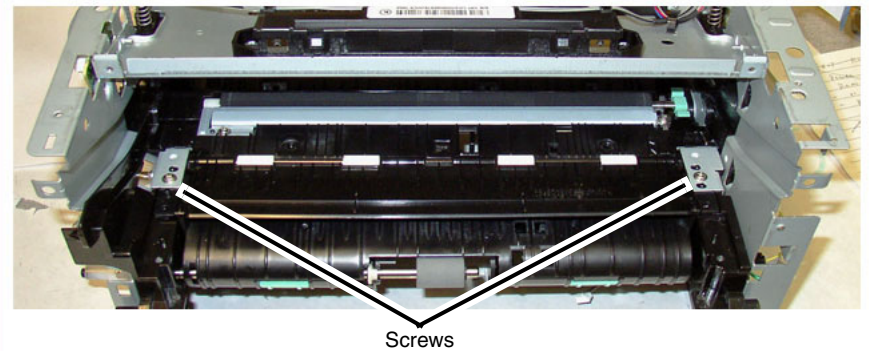

040431RBAT

**Figure 7 Registration Pinch Rolls and Paper Guide Brackets**

10. Lift the Pinch Rolls and Paper Guide out of the printer, then remove the Feed Assembly upper half, [Figure 8](#).

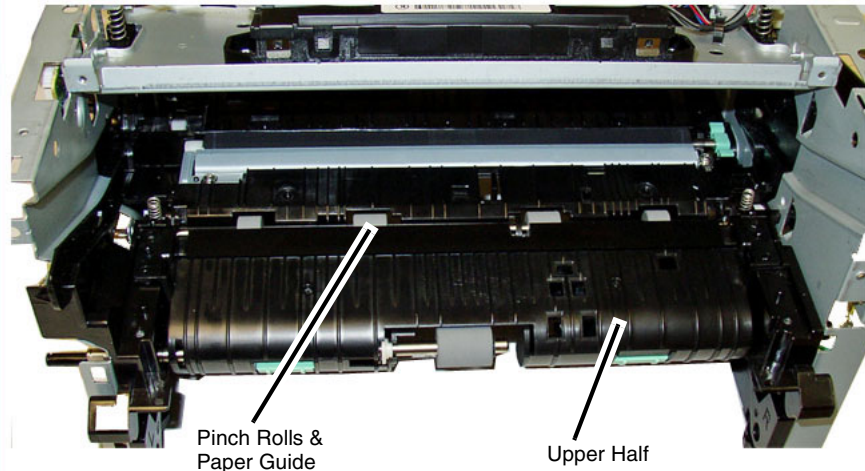

040432RBAT

**Figure 8 Registration Pinch Rolls and Paper Guide**

11. Remove the Feed Assembly lower half, then remove the Drive Roll from the Feed Assembly lower half, [Figure 9](#).

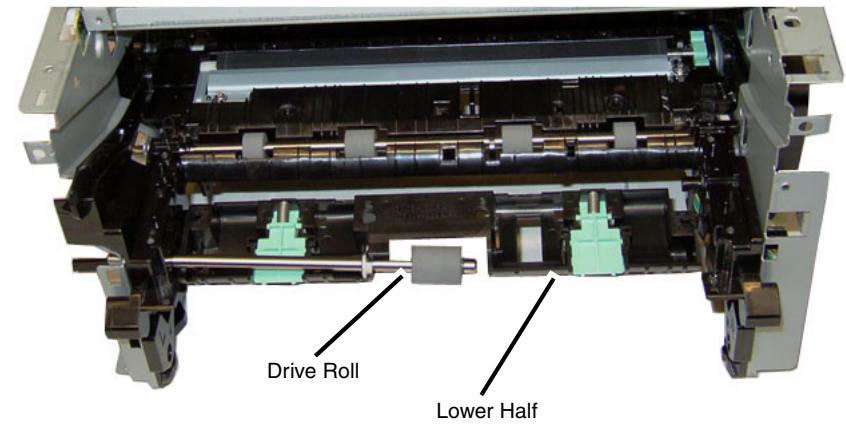

040433RBAT

**Figure 9 Feed Assembly Lower Half**

12. Remove the snap rings and bushing from the Drive Roll Shaft, [Figure 10](#).

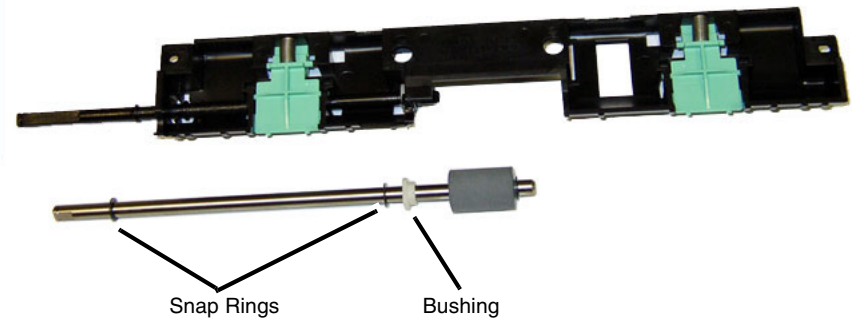

040434RBAT

**Figure 10 Drive Roll**

## Replacement

**NOTE:** Tapered plastic screws and round machine screws are used to hold the cover to the frame. Make sure that the plastic screws go into plastic components and machine screws go into the metal frame.

The replacement is the reverse of the removal procedure.

1. When replacing the Drive Roll in the Feed Assembly lower half make sure the flat on the bushing aligns with the flat on the assembly
2. After installing the Feed Assembly upper half, install the two Feed Assembly bottom screws, then route the wires through the frame, [Figure 6](#).

## REP 4.14 Paper Feed Roll Assembly

Parts List on [PL 4.5](#)

### Removal

1. Switch off the printer, then disconnect the power cord.
2. Remove the Paper Cassette.
3. Remove the Automatic Document Feeder (ADF), [REP 1.3](#).
4. Remove the Left and Right Side Covers, [REP 2.2](#).
5. Set the printer so the Front of the printer facing up.
6. Remove two screws, then remove the bottom bar, [Figure 1](#).

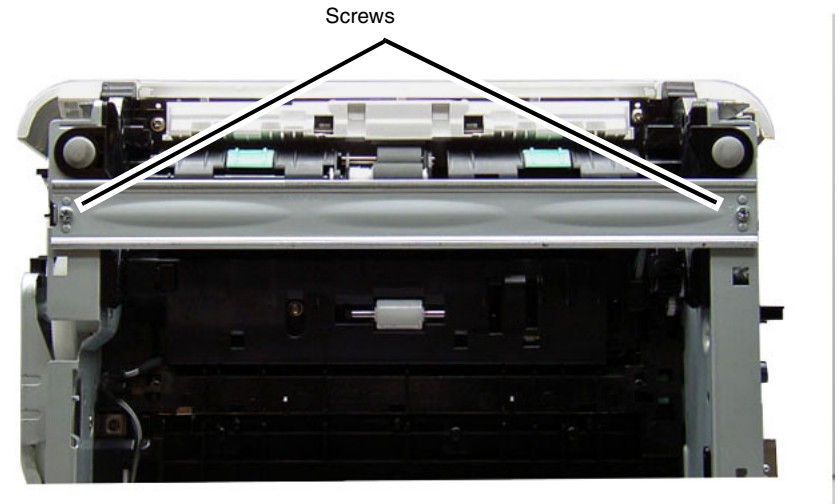

040436RKB

Figure 1 Bottom Bar (Bottom View)

- Remove two screws, pull the right side of the assembly out of the printer, then slide the assembly out to the right removing Feed and Forward Roll Assembly, [Figure 2](#).

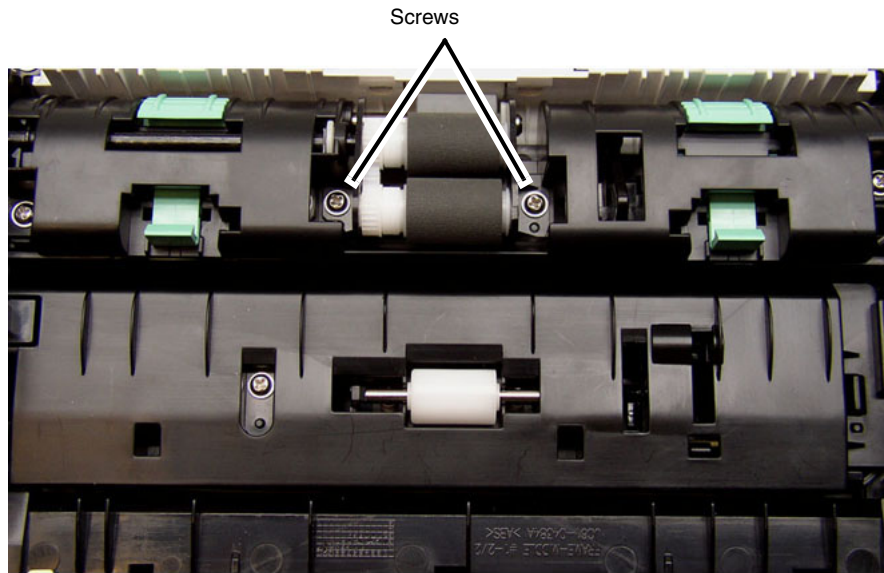

040437RKB

**Figure 2 Removing the Feed and Forward Roll Assembly (Bottom View)**

- Remove the Feed and Forward Rolls from the assembly, [Figure 3](#).



040438RKB

**Figure 3 Feed and Forward Roll Assembly**

## Replacement

**NOTE:** Tapered plastic screws and round machine screws are used to hold the cover to the frame. Make sure that the plastic screws go into plastic components and machine screws go into the metal frame.

The replacement is the reverse of the removal procedure.

**NOTE:** When replacing the Feed and Forward Roll Assembly made sure the flat on the bushing is lined up with the flat on the assembly, [Figure 4](#).

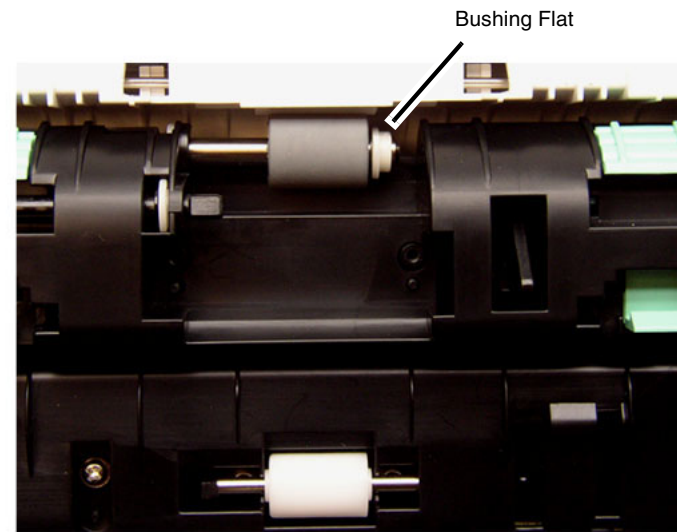

040439RKB

**Figure 4 Bushing Flat (Bottom View)**



## REP 4.15 Main Drive Motor

### Parts List on PL 4.6

#### Removal

1. Switch off the printer, then disconnect the power cord.
2. The Left and Right Side Covers, [REP 2.2](#).
3. The Front Cover, [REP 2.1](#).
4. The Rear Cover, [REP 2.3](#).
5. The Middle Covers, [REP 2.5](#).
6. Remove the Duplex, [REP 4.2](#).
7. Remove the Main Drive Unit, [REP 4.17](#).

8. Remove the Feed and Registration Clutch Assembly and the PWB, [Figure 1](#):
  - a. Disconnect CN3 from the Joint PWB, then remove the screw.
  - b. Remove the snap rings and washers from the Clutches, then remove the Feed and Registration Clutches.
  - c. Release two latches, then remove the Feed and Registration Clutch Assembly and the PWB.

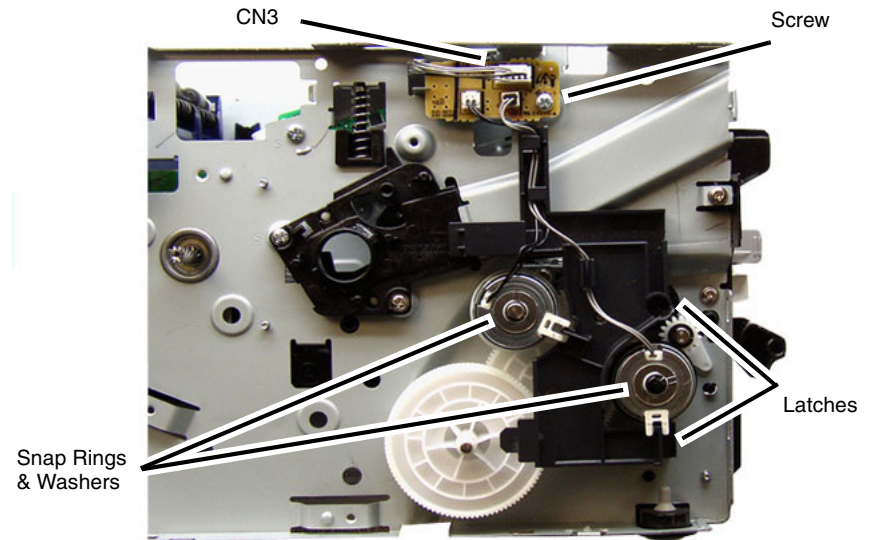

040446RKB

Figure 1 Feed and Registration Clutch / Feeder PWB

9. Remove the Feed and Registration Clutch Drive Gears, [Figure 2](#).

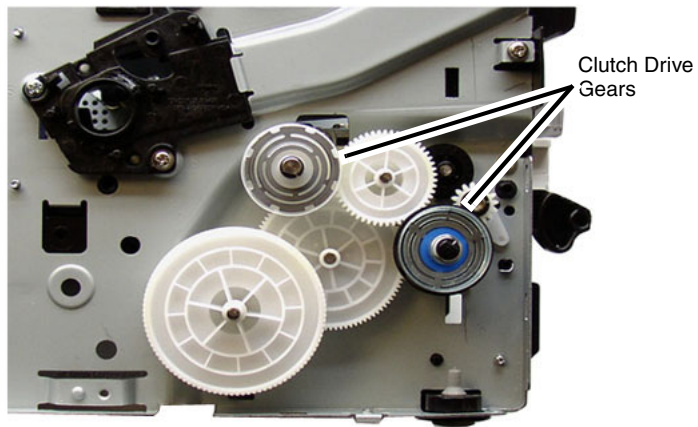

040447RKB

**Figure 2 Feed and Registration Clutch Drive Gears**

10. Remove the following parts, [Figure 3](#):

Make note of the order that the Feed and Registration Drive Gears were removed so that they may be re-installed correctly.

- Feed and Registration Drive Gears, there is a Snap Ring on one gear.
- Feed and Registration Clutch Bushings (2 Snap Rings).
- Exit Drive Gears, (2 screws and a Latch).

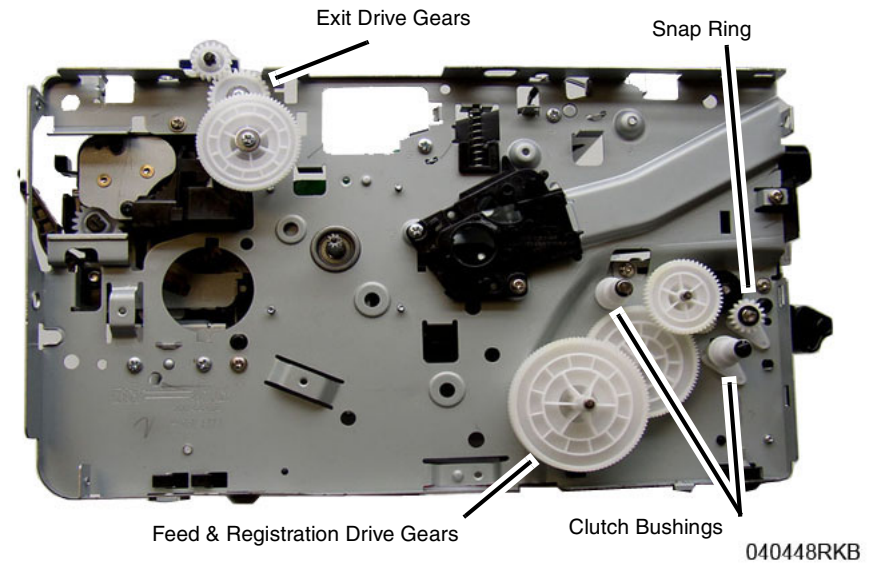

040448RKB

**Figure 3 Drive Gears and Bushings**

11. Remove the following from the Left Frame, [Figure 4](#):
  - a. Shaft Bushings (2), release the latches.
  - b. LSU Assembly Support (2 screws).
  - c. Paper Path Module screws (5).

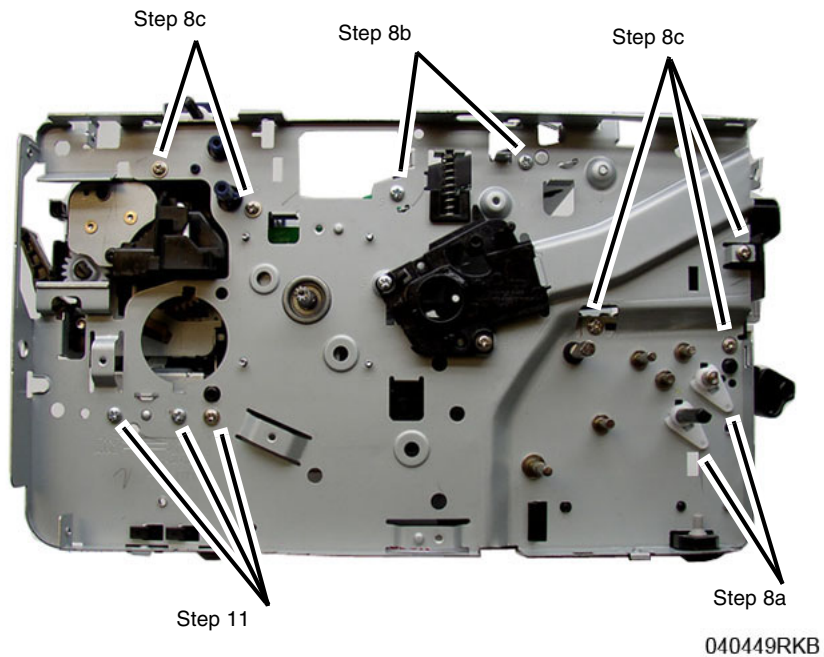

**Figure 4 Left Frame parts removal**

040449RKB

12. On the bottom of the Printer, [Figure 5](#):
  - a. Disconnect the Drive Motor Connector.
  - b. Remove the screw (1) and the Ground Clip.

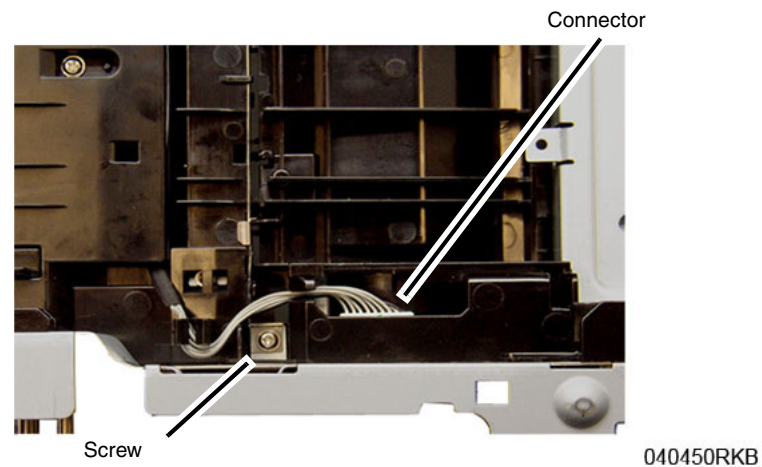

**Figure 5 Drive Motor Connector & Ground Clip (Bottom View)**

040450RKB

13. Remove three screws attaching the Left Frame.
14. Remove four screws, then remove the Drive Motor, [Figure 6](#).

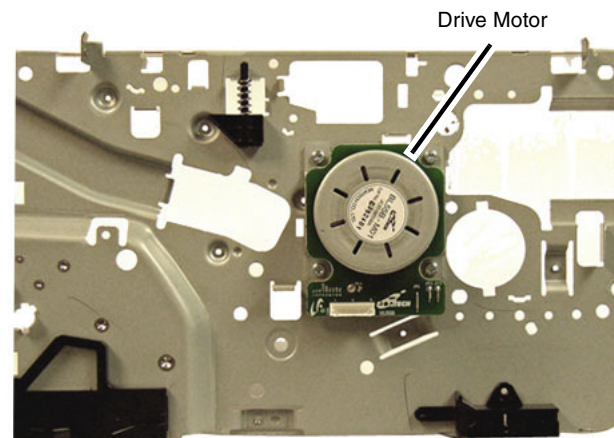

**Figure 6 Drive Motor**

040451RKB

## Replacement

**NOTE:** Tapered plastic screws and round machine screws are used to hold the cover to the frame. Make sure that the plastic screws go into plastic components and machine screws go into the metal frame.

1. Install the new Drive Motor.

**NOTE:** The Frame is flexible and can be bowed out if the screws are not tightened in the correct order.

Reinstall the Frame as follows so it seats flush against the printer's internal modules.

2. Align the Frame on to the internal modules and shafts.

**NOTE:** Do Not fully tighten the screws in Step 3 until instructed.

3. Install, but do not tighten, the following module screws, [Figure 7](#):

- a. The Exit Sensor Plate screws (2).
- b. The Front Paper Path Module screws (3).

4. On the bottom of the Printer, install the ground clip with the screw, then connect the Drive Motor connector, [Figure 7](#).

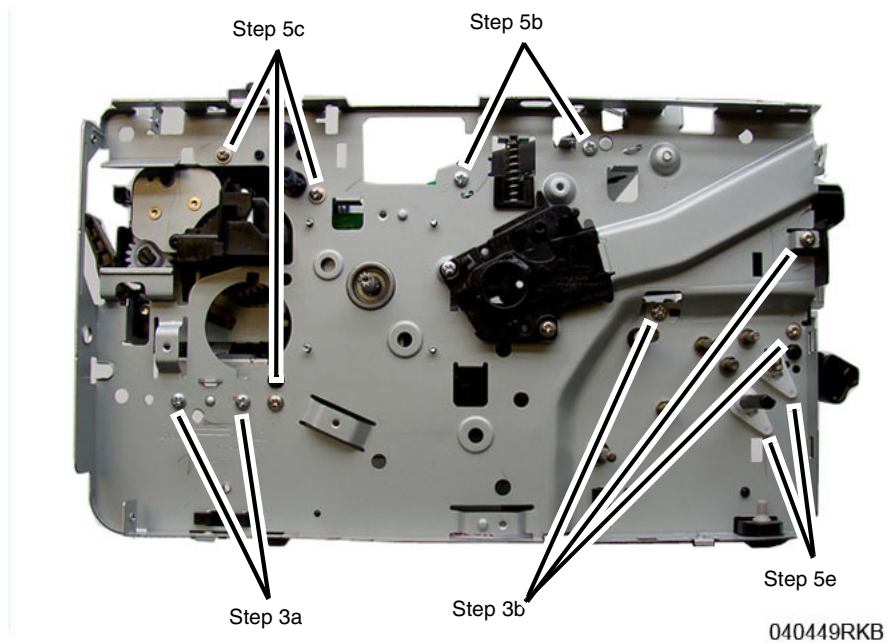
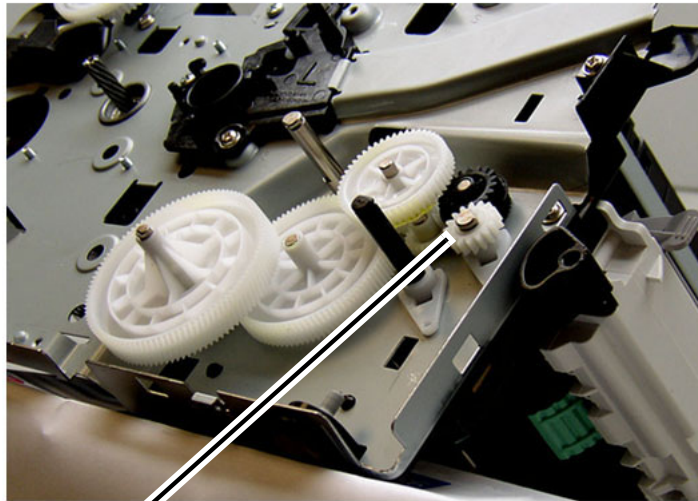

Figure 7 Frame Screw Installation



5. Install and tighten the Frame screws from the center of the Frame; to the front of the printer, then to the rear of the Printer. Install the shaft bushings (2), [Figure 8](#).
  - a. Tighten the Front Paper Path Module screws (3) installed in Step 3b.
  - b. The ROS Support screws (2)
  - c. The Rear Paper Path Module screws (3)
  - d. Tighten all the Exit Sensor Plate screws (2) installed in Step 3a.
  - e. Shaft Bushings (2).
  - f. Install the Drive Gears and Snap Ring.
6. Install the remaining components in the reverse of removal.  
When installing the Front Cover Support Arm make sure it is correctly placed on the Stop Bracket, [Figure 9](#).



Snap Ring

040452RKB

**Figure 8 Feed and Registration Drive Gears**

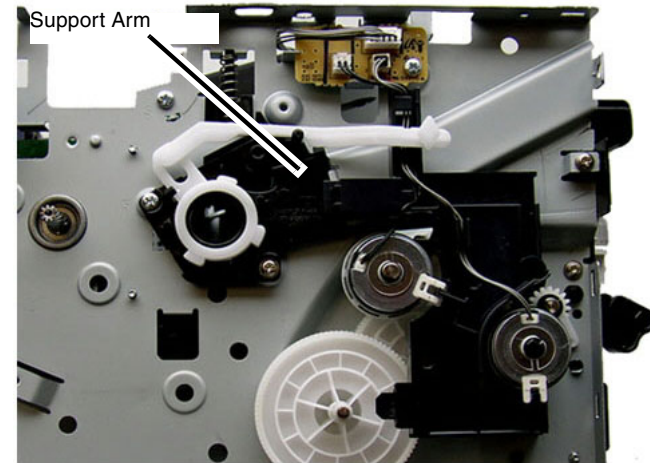

040443RKB

**Figure 9 Front Cover Support Arm Placement**

## REP 4.16 Paper Feed Idler Gear

Parts List on [PL 4.6](#)

### Removal

1. Switch off the machine, then disconnect the power cord.
2. Remove the Left Side Cover, [REP 2.2](#).
3. Remove the Feed Clutch and Drive Gear, [Figure 1](#):
  - a. Remove the E-ring and Washer from the Feeder Clutch.
  - b. Remove the Feeder Clutch and Drive Gear.

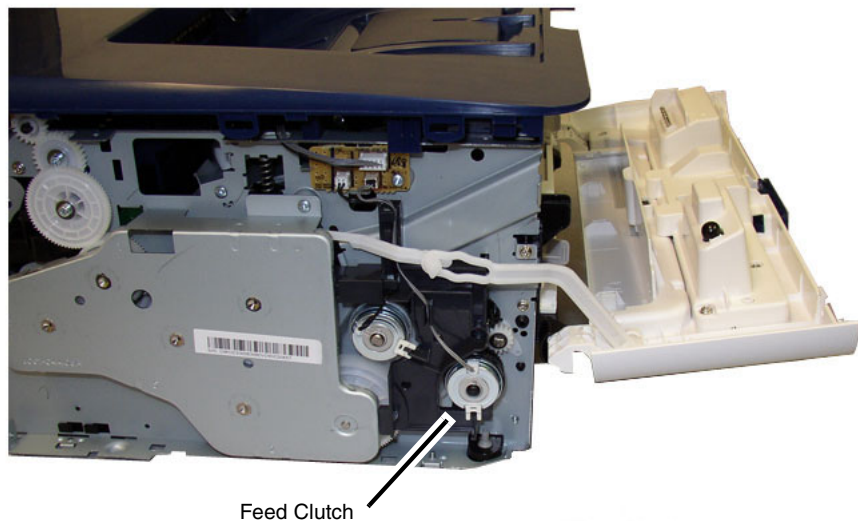

Feed Clutch

Figure 1 Feed Clutch Removal

040401RKB

4. Remove the Snap Ring and Idler Gear, [Figure 2](#).

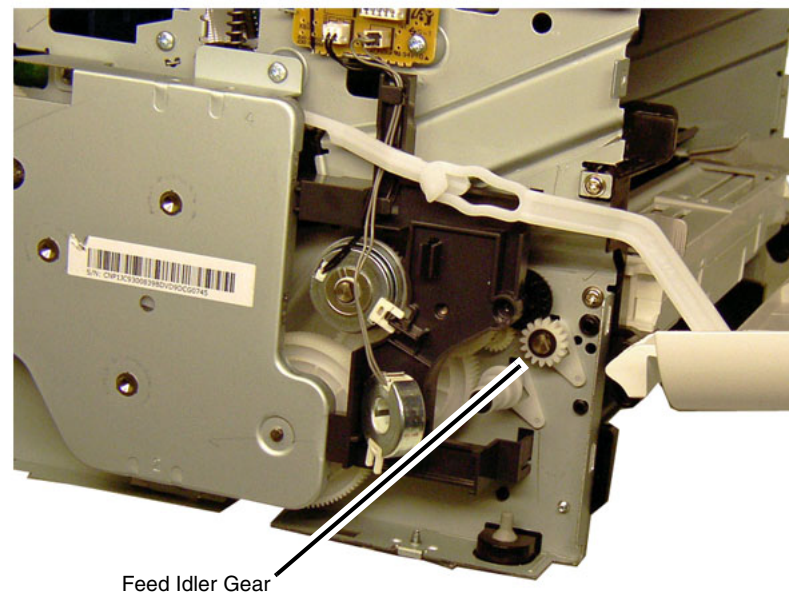

Feed Idler Gear

Figure 2 Feed Idler Gear

040427RBAT

### Replacement

The replacement is the reverse of the removal procedure.

## REP 4.17 Main Drive Unit

Parts List on [PL 4.6](#)

### Removal

1. Switch off the printer, then disconnect the power cord.
2. Remove the Left Side Cover, [REP 2.2](#).
3. Remove the Main Drive Unit, [Figure 1](#).
  - a. Remove five screws securing the Main Drive Unit.
  - b. Move the fuser drive locking lever to the unlock position (Right).
  - c. Remove the Main Drive Unit and the front door support arm.

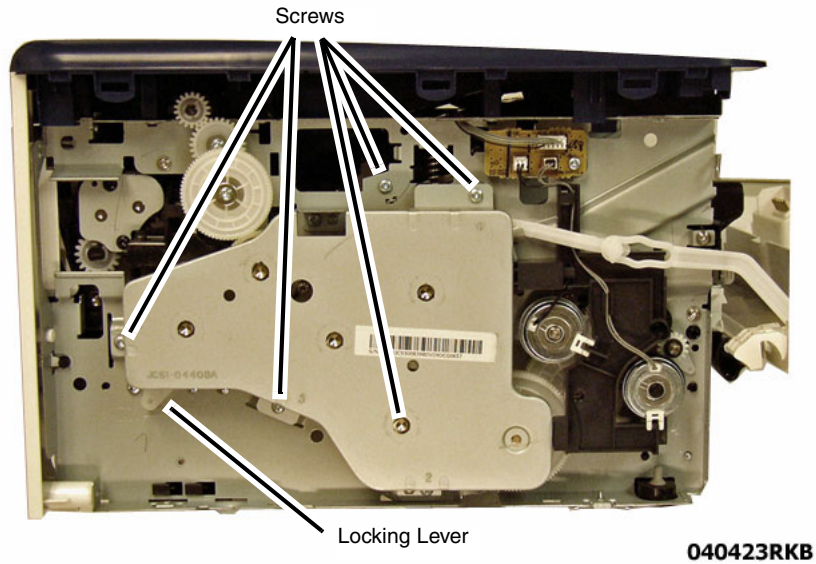

Figure 1 Main Drive Unit Removal

### Replacement

1. Place the front cover support arm on the stop bracket, [Figure 1](#).

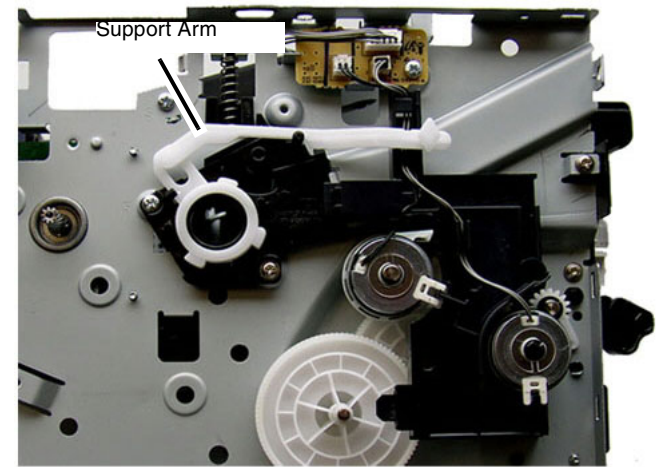

Figure 2 Front Cover Support Arm Placement

2. Replacement is the reverse of the removal procedure.



**NOTE:** Make sure the Tabs (2) on the Locking Lever are inside the Frame cutouts before moving the Fuser Drive Locking Lever to the Lock position.

3. Align the Locking Lever Tabs (2) to the cutouts in the frame, [Figure 3](#).

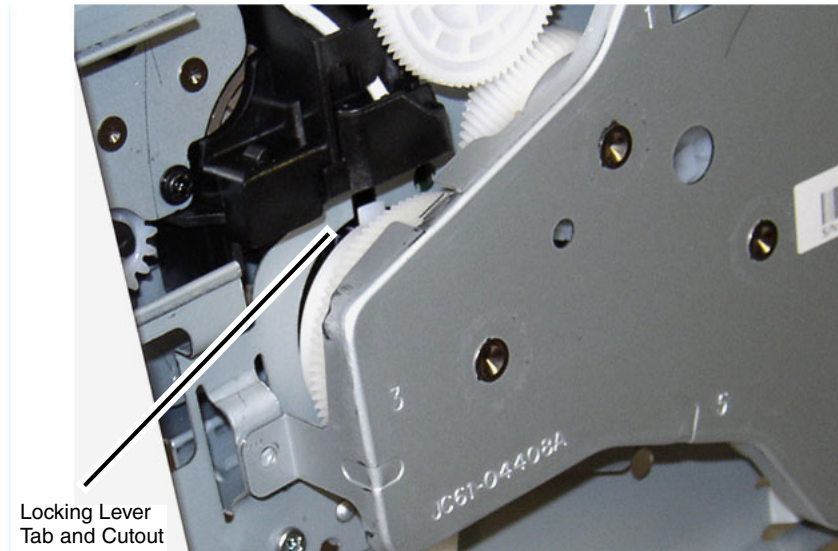

Locking Lever Tab and Cutout

040424RKB

**Figure 3 Locking Lever Tab and Frame Cutout**

4. Press in on the Locking Lever to move the Tabs into the cutouts. Move the Locking Lever to the Lock position (Left).
5. Install the remaining components in the reverse of removal.

## REP 4.18 Pick Up Assembly

Parts List on [PL 4.5](#)

### Removal

1. Remove two screws, remove the one-way pickup frame from the upper pickup guide, then remove the bushing from the one-way pickup frame, [Figure 1](#).

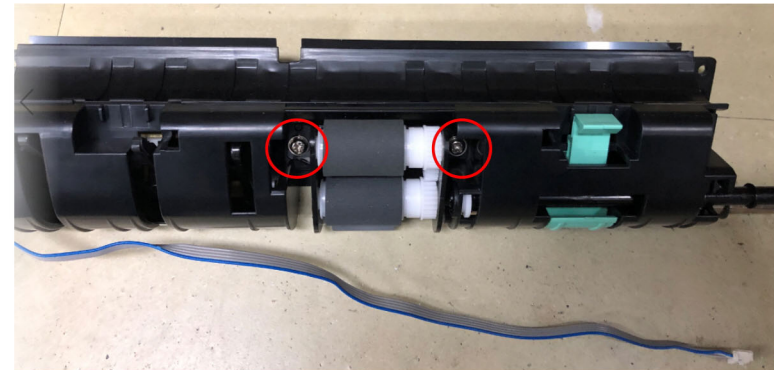
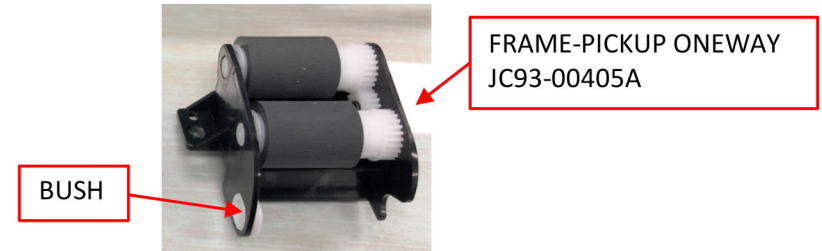

N-1-0042-A

**Figure 1 One-way pickup frame and bushing removal**

2. Remove the pickup guide from the upper pickup guide, [Figure 2](#).

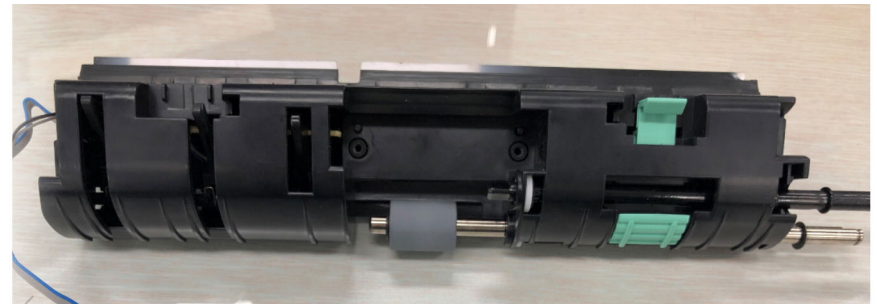

N-1-0041-A

**Figure 2 Pickup guide removal**

- Remove the feed roll and pickup shaft from the pickup guide, [Figure 3](#).

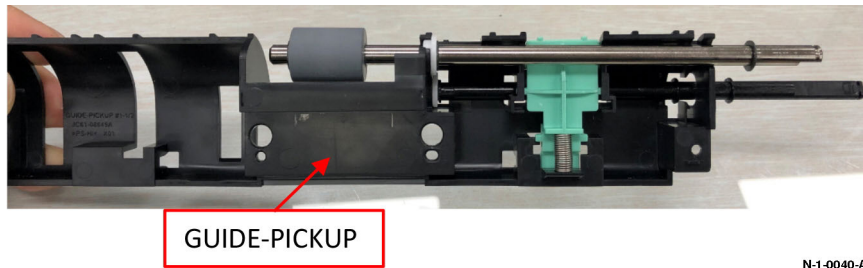

GUIDE-PICKUP

N-1-0040-A

**Figure 3 Feed roll and pickup shaft removal**

- Remove the washer from the feed roller and the bushing from the pickup shaft, [Figure 4](#).

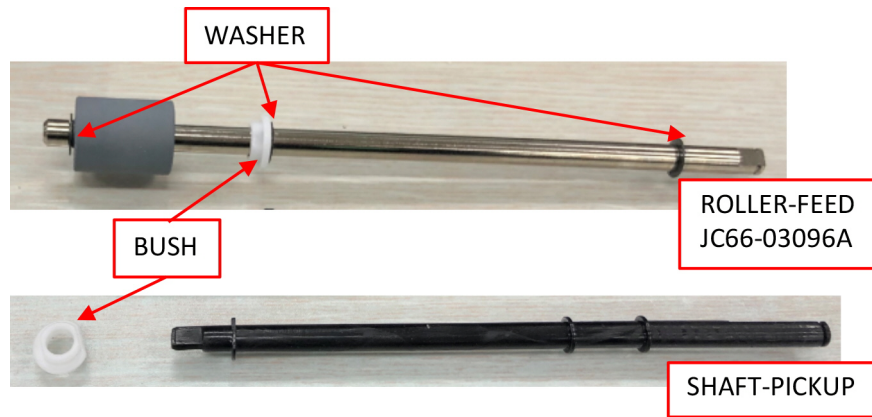

WASHER

BUSH

ROLLER-FEED  
JC66-03096A

SHAFT-PICKUP

N-1-0039-A

**Figure 4 Washer and bushing removal**

- Remove the width actuator and paper actuator from the upper pickup guide, [Figure 5](#).

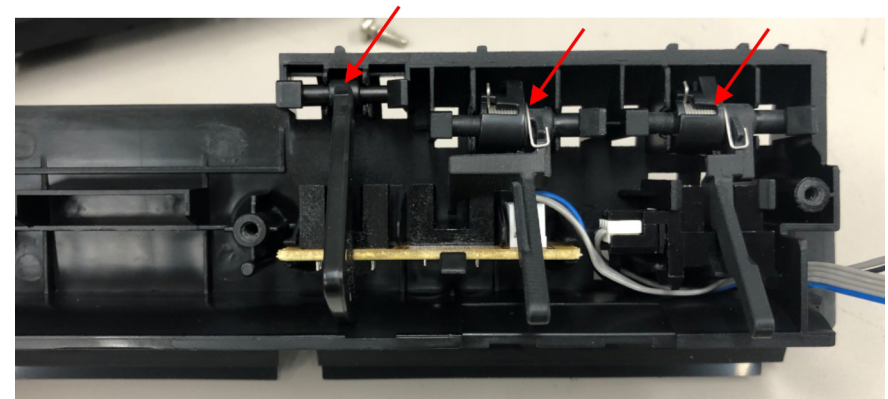

N-1-0038-A

**Figure 5 Actuator removal**

- Remove the actuator holder and TS-spring from the width and paper actuators, [Figure 6](#).

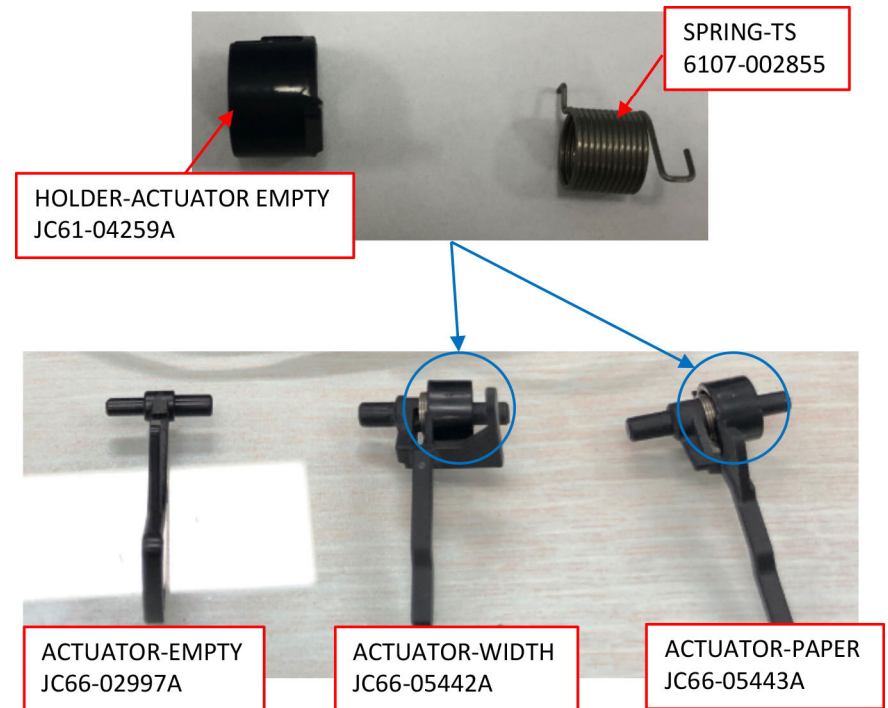

SPRING-TS  
6107-002855

HOLDER-ACTUATOR EMPTY  
JC61-04259A

ACTUATOR-EMPTY  
JC66-02997A

ACTUATOR-WIDTH  
JC66-05442A

ACTUATOR-PAPER  
JC66-05443A

N-1-0037-A

**Figure 6 Actuator holder and TS-spring removal**

7. Remove the feed sensor and feed sensor PWB, [Figure 7](#).

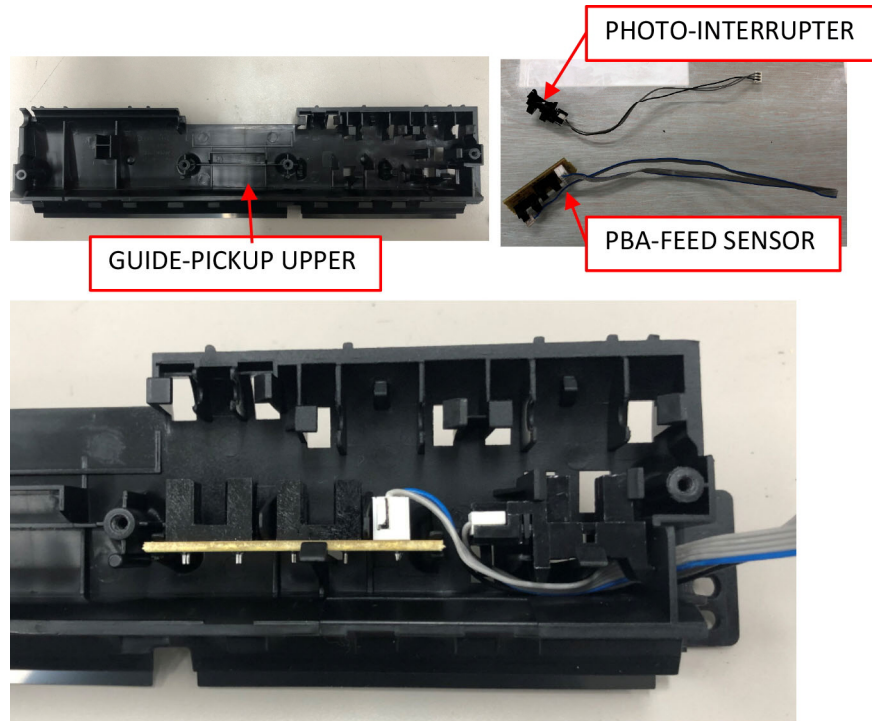

Figure 7 Feed sensor and PWB removal

N-1-0036-A

## Replacement

Replacement is the reverse of the removal procedure.

## REP 5.1 Fuser Module

Parts List on [PL 5.1](#)

### Removal

#### WARNING

Do not perform repair activities with the power on or electrical power supplied to the machine. Some machine components contain dangerous electrical voltages that can result in electrical shock and possible serious injury.

**DANGER:** Ne pas effectuer de dépannage avec le contact principal activé ou avec l'alimentation électrique appliquée à la machine. Certains éléments de la machine comportent des tensions électriques dangereuses qui peuvent causer un choc électrique et de graves blessures.

**AVVERTENZA:** Non effettuare alcuna riparazione con l'alimentazione elettrica inserita. Alcuni componenti contengono corrente ad alta tensione che può provocare forti scosse e gravi ferite.

**VORSICHT:** Es dürfen erst Reparaturarbeiten durchgeführt werden, wenn das Gerät ausgeschaltet ist oder der Netzstecker nicht mehr mit der Stromquelle verbunden ist. Einige Komponenten des Gerätes sind stromführend und können daher zu ernsthaften Verletzungen oder Stromschlägen führen.

**AVISO:** No realice reparaciones con la máquina encendida o conectada a la corriente. Algunos componentes de la máquina contienen voltajes eléctricos peligrosos que pueden producir una descarga eléctrica y causar daños graves.

#### WARNING

Do not handle the fuser components until they have cooled. Some fuser components operate at hot temperatures and can produce serious personal injury if touched.

**DANGER:** Ne pas manipuler les éléments du four avant de les laisser refroidir. Certains éléments du four fonctionnent à des températures très élevées et peuvent causer de graves blessures s'ils sont touchés.

**AVVERTENZA:** Non maneggiare i componenti del fusore finché non sono raffreddati. Alcuni di questi componenti funzionano ad alte temperature e possono provocare gravi ferite se vengono toccati.

**VORSICHT:** Die Fixieranlage sollte erst gehandhabt werden, wenn diese genügend abgekühlt ist. Einige Teile der Fixieranlage erzeugen übermäßige Hitze und führen bei der Berührung zu schweren Verbrennungen.

**AVISO:** No manipule los componentes del fusor antes de que se enfríen. Algunos de los componentes del fusor funcionan a altas temperaturas y pueden ocasionar daños personales graves si se los toca.

1. Switch Off the Printer and disconnect the Power Cord.
2. Remove the following covers:
  - a. Remove the Left and Right Side Covers, [REP 2.2](#).
  - b. Remove the Rear Cover [REP 2.3](#).



3. Disconnect the Fuser Connectors (2), **Figure 1**.
  - a. Connector CON 2 from the LVPS PWB.
  - b. Connector FUSER from the Main PWB.

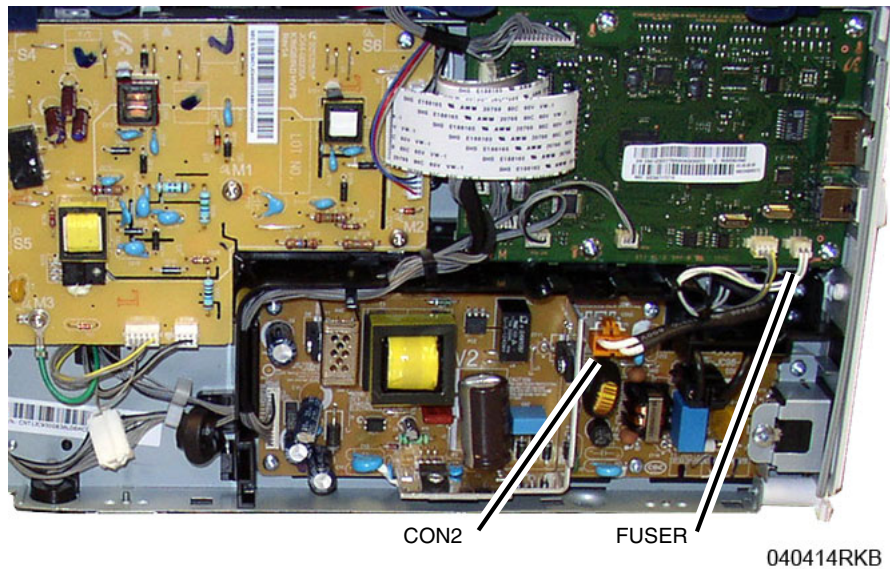

**Figure 1 Fuser Connectors**

**NOTE:** Remember the location of the Screw with the larger head for Fuser replacement.

4. Remove the Fuser Module screws (4), **Figure 2**.  
Remove the Fuser, routing the wires through the frame opening.

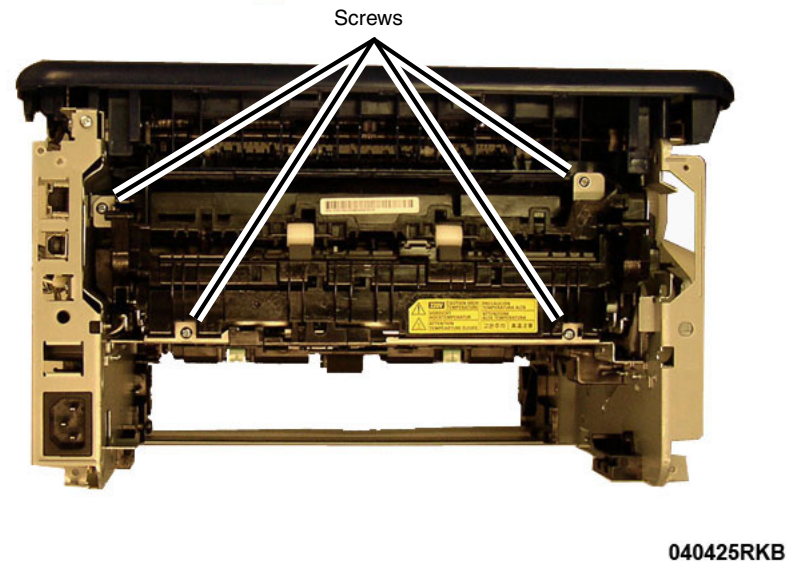

**Figure 2 Fuser Screws (Rear View)**

### Replacement

**NOTE:** Tapered Plastic Screws and Round Machine Screws are used to hold the Fuser to the frame. Make sure that the Plastic Screws go into plastic components and Machine Screws go into the metal frame.

Install the components in the reverse of removal.

## REP 6.1 Retard Roll

### Parts List on PL 6.1

#### Removal

1. Remove the Paper Cassette and any paper from the tray.
2. In the Cassette, pull down on the latches (2) to open the Retard Roll Cover, [Figure 1](#).

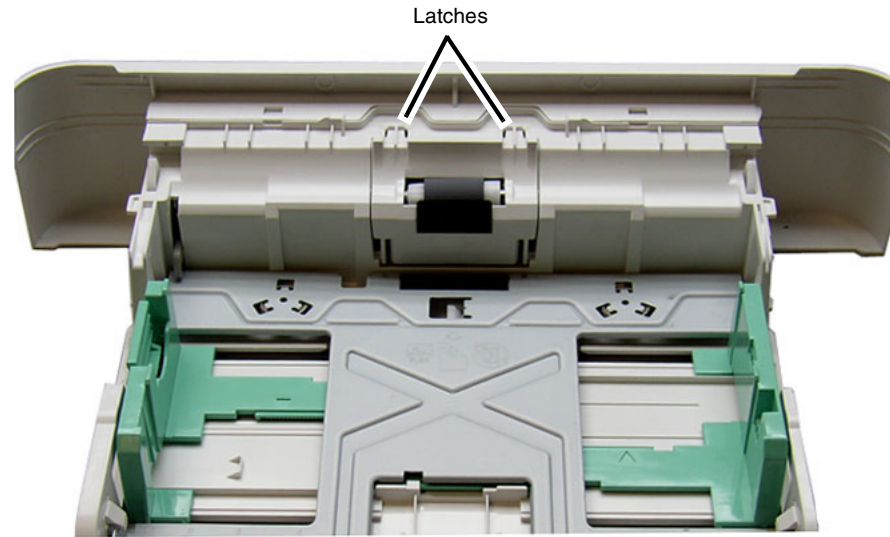

040432RKB

Figure 1 Retard Roll Cover Latches

3. Rotate the Retard Roll Holder up and remove it from the Cassette, [Figure 2](#).

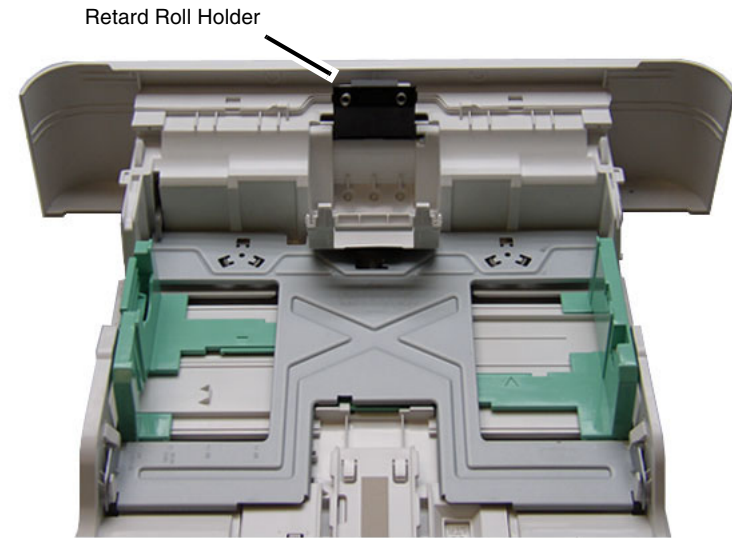

0040433RKB

Figure 2 Retard Roll Holder Removal

4. Slide the left side of the Retard Roll out of the holder and remove it, [Figure 3](#).

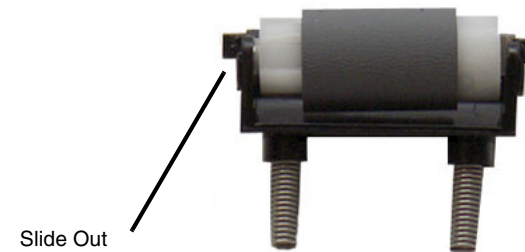

040434RKB

Figure 3 Retard Roll Removal



## Replacement

1. The replacement is the reverse of the removal procedure.

**NOTE:** Make sure the Springs (2) on the Retard Roll Holder are correctly positioned in the holes, [Figure 4](#).

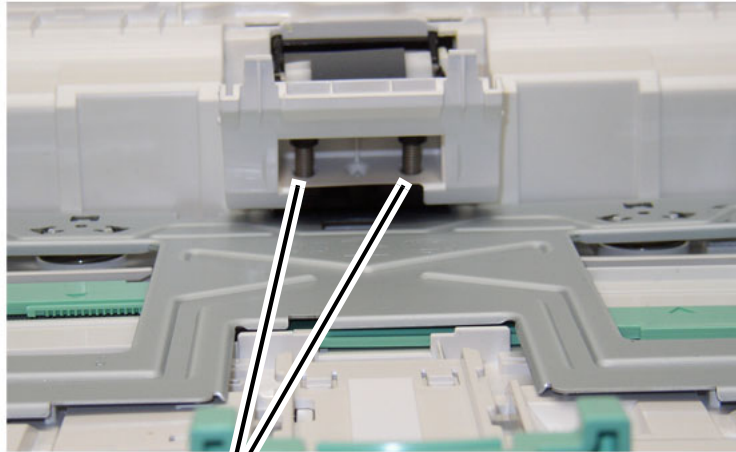

Springs

040435RKB

Figure 4 Springs in Holder

## REP 7.1 Bracket - Connector

Parts List on [PL 7.1 \(B205\)](#)

Parts List on [PL 7.2 \(B215\)](#)

### Removal

1. Remove the ADF, [REP 1.2 \(B215\)](#)
2. Remove the Control Panel, [REP 8.2 \(B205\)](#), [REP 8.2 \(B215\)](#).
3. Push down on the top of the scanner Front Cover to release five latches on the top of the scanner Front Cover, then remove the front cover, [Figure 1](#).



N-1-0010-A

Figure 1 Scanner top cover

4. Remove five screws, then remove the Upper Scanner Frame, [Figure 2](#).

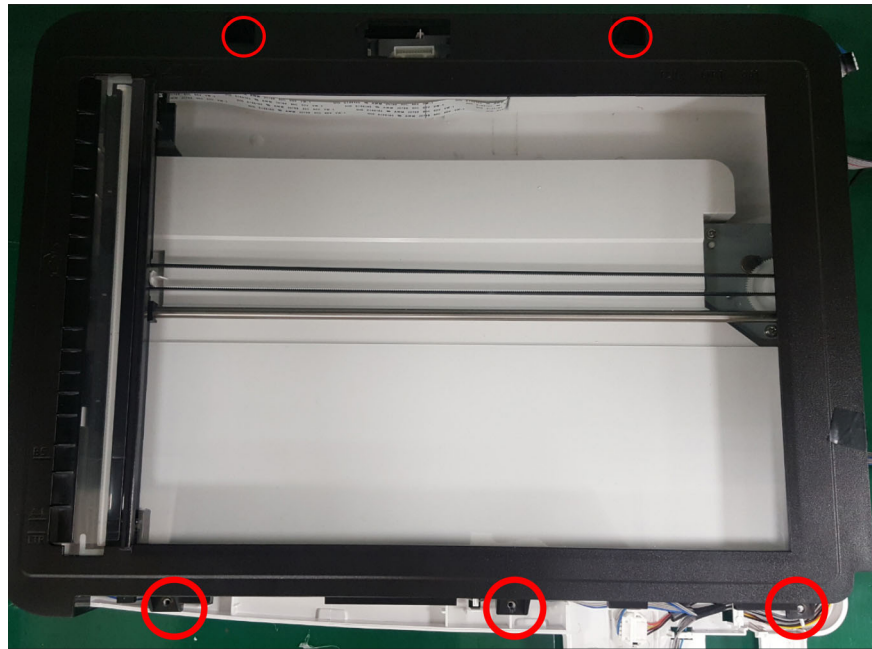

N-1-0011-A

Figure 2 Upper scanner frame removal

5. Remove two screws, then remove the Bracket-Connector and harness, [Figure 3](#).

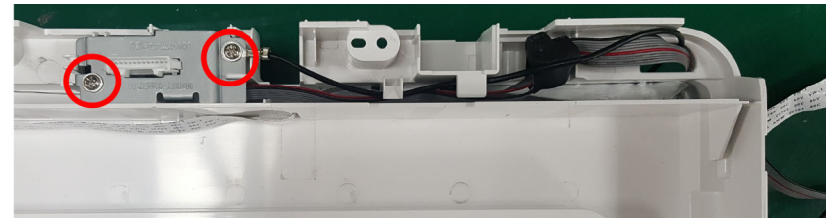

HARNESS-ADF JOINT  
JC39-02455A

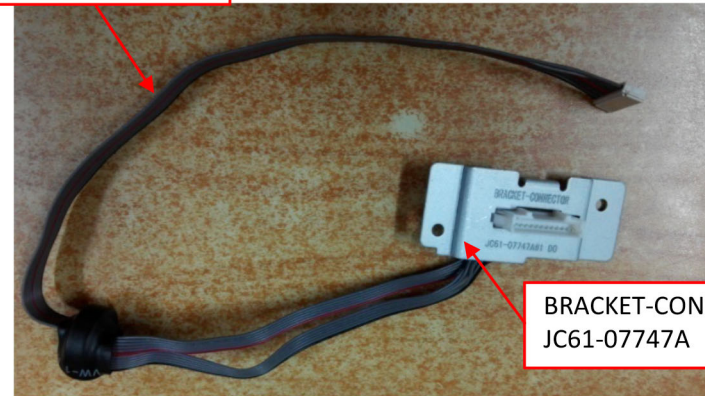

BRACKET-CONNECTOR  
JC61-07747A

N-1-0012-A

Figure 3 Bracket-Connector removal

## Replacement

1. Begin by aligning the bracket to the mounting screw holes in the lower scanner frame, then dress the harness back into the lower scanner frame harness guides, [Figure 4](#).

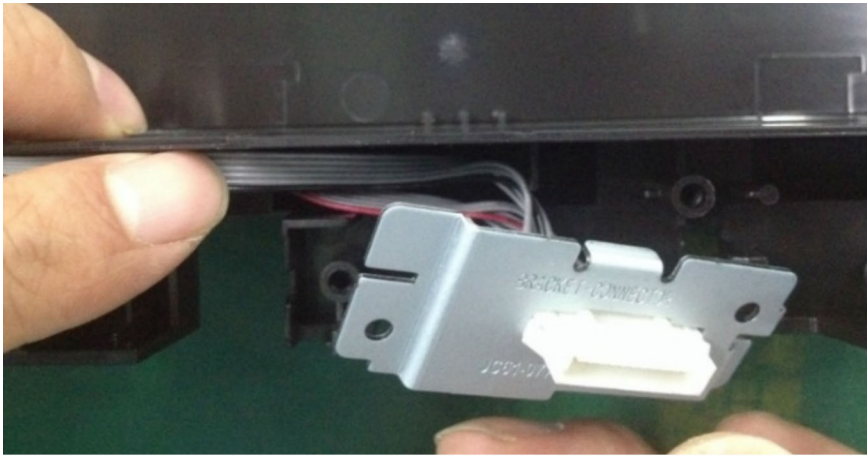

N-1-0014-A

Figure 4 Bracket and harness alignment

2. Replace the screw on the right, first, then properly route and attach the ground wire to the bracket with the left screw, [Figure 5](#).

**NOTE:** Ensure the bracket is correctly in-place within the lower scanner frame as shown in [Figure 6](#). The slot in the bracket near the ground screw and the tab near the opposing screw must be aligned and inserted correctly before tightening the screws to avoid damage.

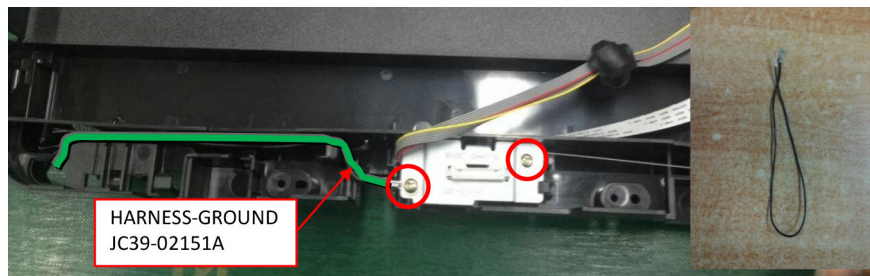

N-1-0015-A

Figure 5 Bracket replacement

3. Ensure the harnesses and bracket are routed as shown in, [Figure 6](#).

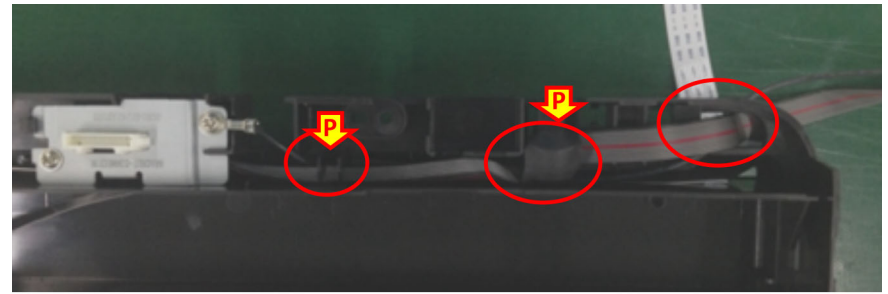

N-1-0016-A

Figure 6 Harness routing

Continue the replacement in the reverse of the removal procedure.

## REP 7.2 Scanner Module

Parts List on [PL 7.1 \(B205\)](#)

Parts List on [PL 7.2 \(B215\)](#)

### Removal

1. Switch off the printer, then disconnect the power cord.
2. Remove the ADF, [REP 1.2](#).
3. Remove the Control Panel, [REP 8.2 \(B205\)](#), [REP 8.2 \(B215\)](#).
4. Remove the Right Side Cover, [REP 2.2](#).
5. Remove two screws at the rear of the middle cover, [Figure 1](#).



N-1-0001-A

Figure 1 Scanner screw removal

6. Disconnect the harnesses from the Main PWB to the ADF / Scanner Assembly and the ground screw, [Figure 2](#).

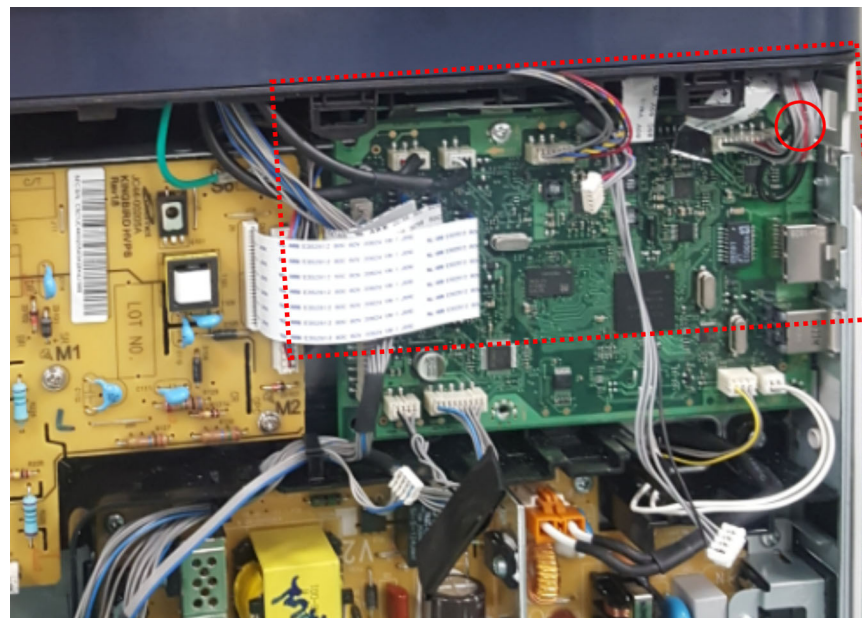

N-1-0004-A

Figure 2 Disconnect harnesses and ground wire



7. Disconnect three connectors on the Main PWB.

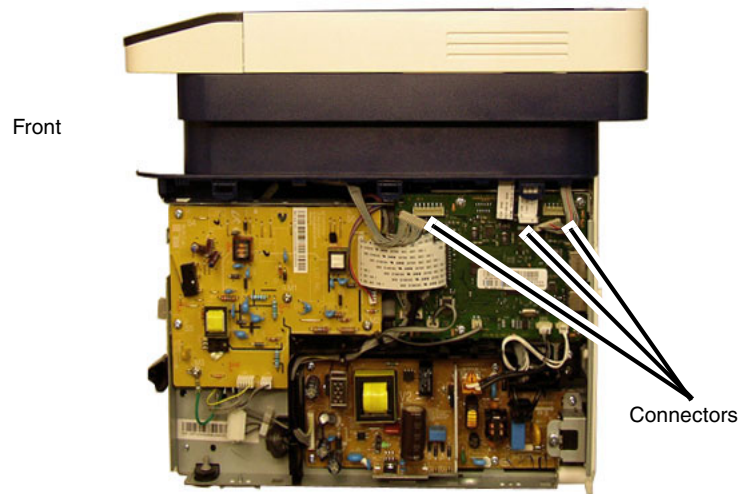

Figure 3 Connector removal

040412aRBAT

8. Slide the Scanner to the front, then lift and remove the Scanner from the IOT routing the wire harnesses through the Middle Cover and out, Figure 4.

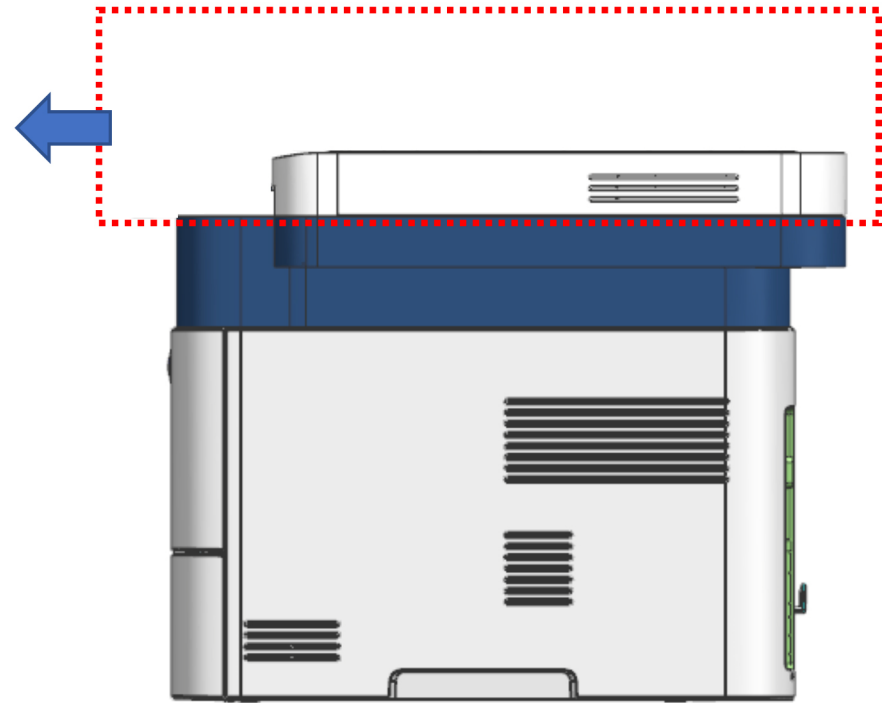

Figure 4 Scanner removal

### Replacement

The replacement is the reverse of the removal procedure.

## REP 8.1 Control Panel (B205)

### Parts List on PL 8.1

#### Removal

1. Switch off the printer, then disconnect the power cord.
2. Remove the Right Side Cover, [REP 2.2](#).
3. Remove the Automatic Document Feeder (ADF), [REP 1.5](#).
4. Remove the Scanner Module, [REP 7.2](#).
5. Remove four screws under the Control Panel, [Figure 1](#).

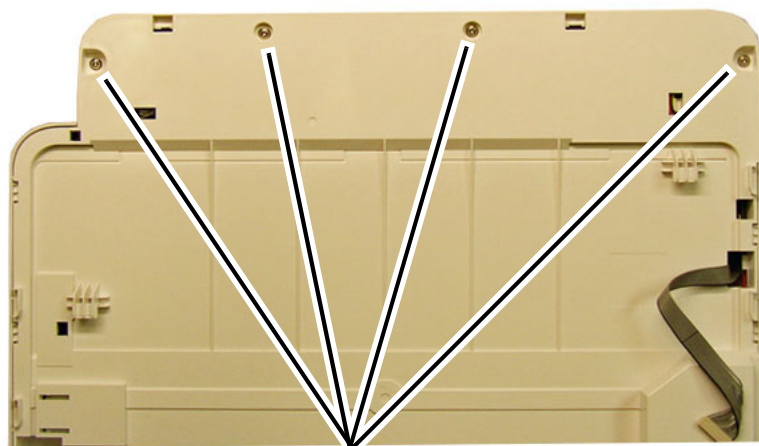

Screws

040413RBAT

Figure 1 Control Panel screw removal

6. Release the Control Panel Assembly by lifting up the front of the panel while pulling it forward, [Figure 2](#).



040414RBAT

Figure 2 Control Panel release

7. Disconnect three Control Panel PWB connectors, then remove the Control Panel, [Figure 3](#).

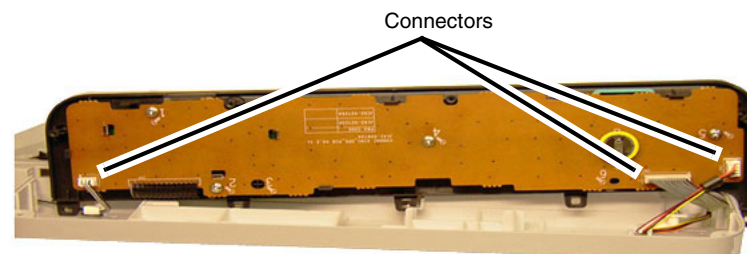

Connectors

040415RBAT

Figure 3 Control Panel removal

#### Replacement

The replacement is the reverse of the removal procedure.

## REP 8.2 Control Panel PWB (B205)

Parts List on [PL 8.1](#)

### Removal

1. Switch off the printer, then disconnect the power cord.
2. Remove the Control Panel, [REP 8.1](#).
3. Remove the Control Panel PWB, [Figure 1](#):
  - a. Remove four screws.
  - b. Release the latches and remove the PWB.

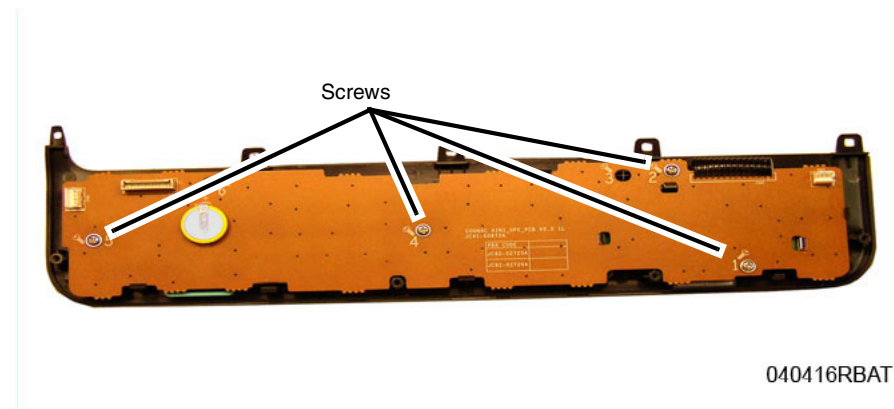

Figure 1 Control Panel PWB removal

### Replacement

The replacement is the reverse of the removal procedure.

## REP 8.3 Control Panel (B215)

Parts List on [PL 8.2](#)

### Removal

1. Switch off the printer, then disconnect the power cord.
2. Remove the Cover-Stopper, [Figure 1](#).



Figure 1 Cover-Stopper removal

N-1-0017-A

3. Fully lift the operator panel to access the two screw covers, then remove the two screw covers to access two screws, [Figure 2](#).

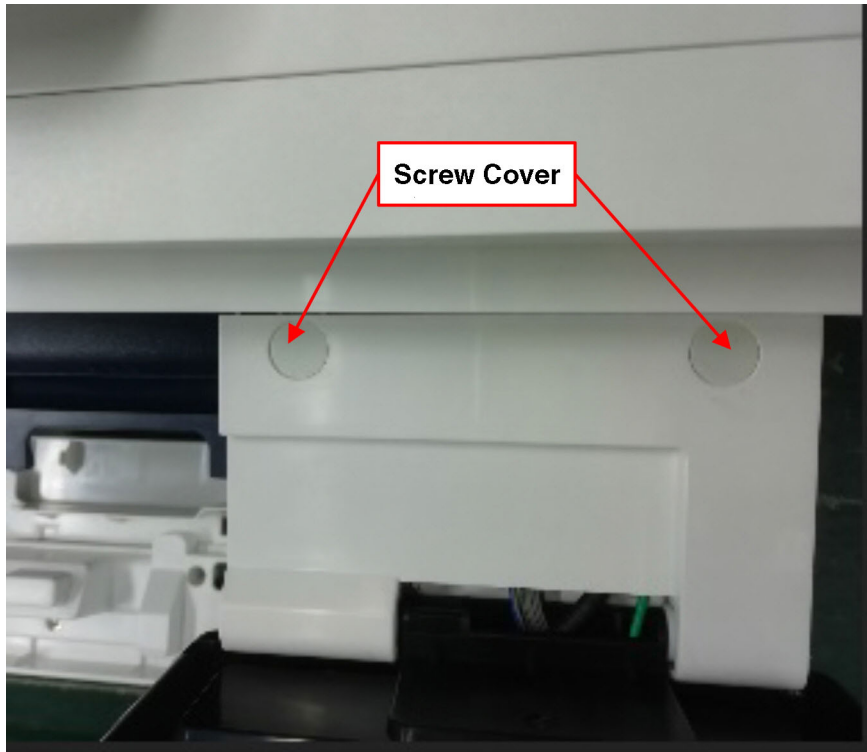
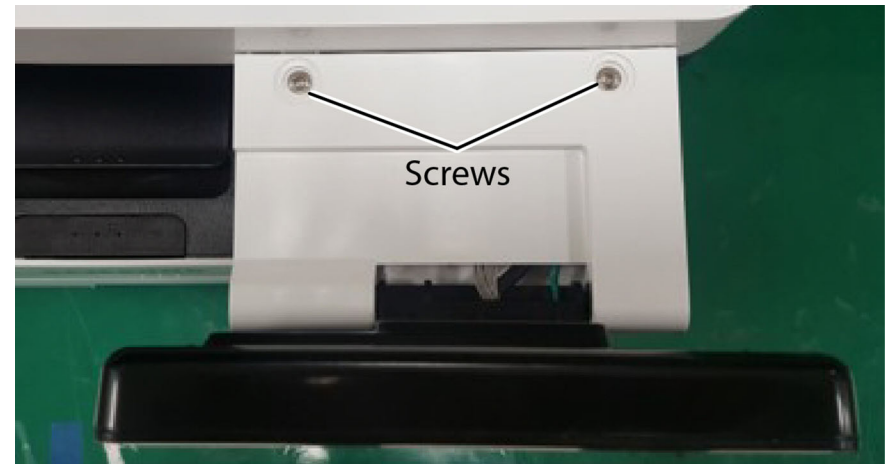

Figure 2 Screw cover removal

N-1-0018-A

4. Remove two screws from the control panel Rear Cover, [Figure 3](#).



N-1-0019-A

Figure 3 Screw removal

5. Release four tabs, then remove the control panel Rear Cover, [Figure 4](#).



N-1-0034-A

Figure 4 Control panel rear cover removal



- Remove three screws, disconnect two connectors and the ground wire, then remove the Control Panel, [Figure 5](#).

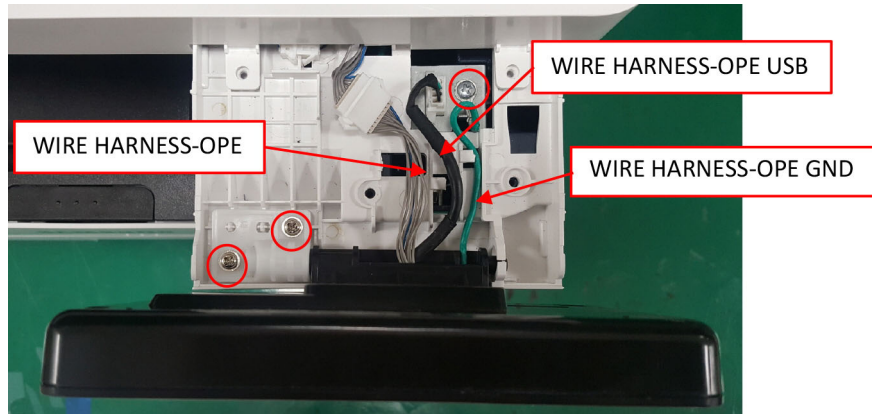

Figure 5 Operator panel removal

N-1-0020-A

### Replacement

The replacement is the reverse of the removal procedure.

## REP 8.4 Control Panel PWB (B215)

Parts List on [PL 8.2](#)

### Removal

- Switch off the printer, then disconnect the power cord.
- Remove the Control Panel, [REP 8.3](#).
- Remove three screws attaching the Lower Cover, then remove the Lower Cover, [Figure 1](#).

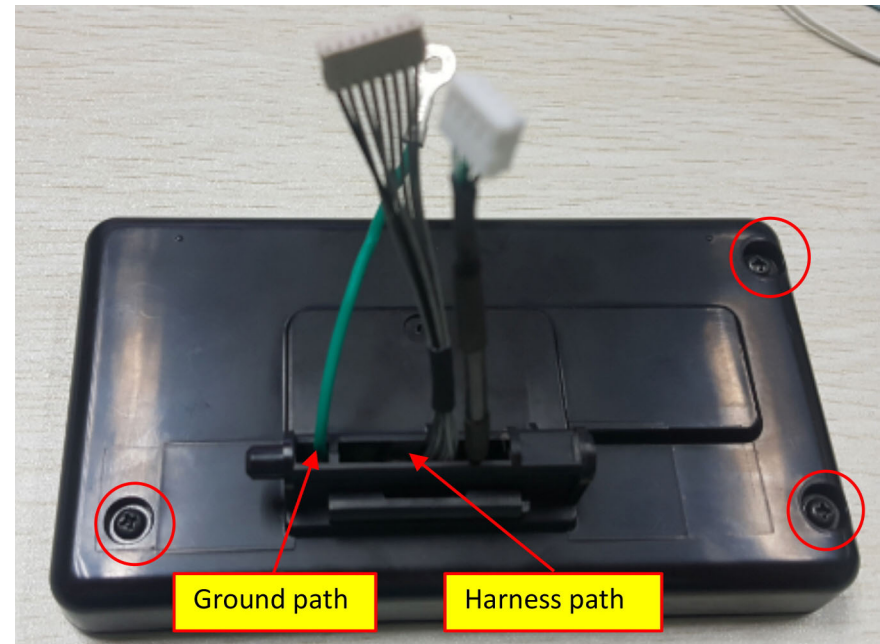

Figure 1 Cover-Stopper removal

N-1-0021-A

4. Remove three screws, disconnect the USB and Control Panel harnesses, then release the hooks and guide boss holding the Control Panel PWB to remove from the Front Cover, [Figure 2](#).

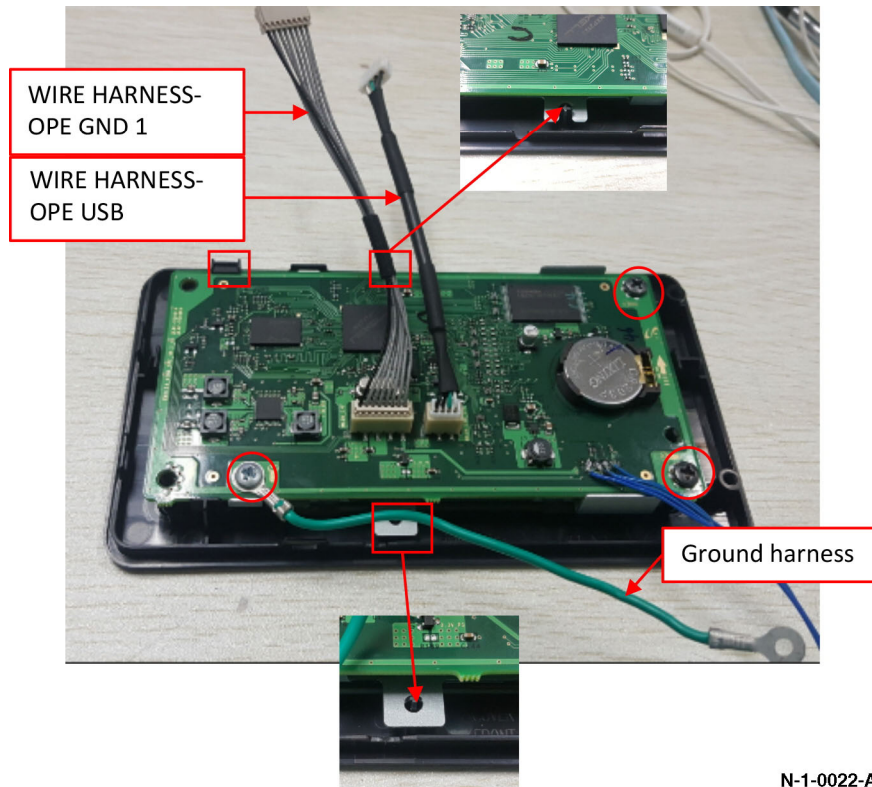

Figure 2 Release the Control Panel PWB

5. Release the Control Panel FFC cable, then remove the Control Panel PWB, [Figure 3](#).

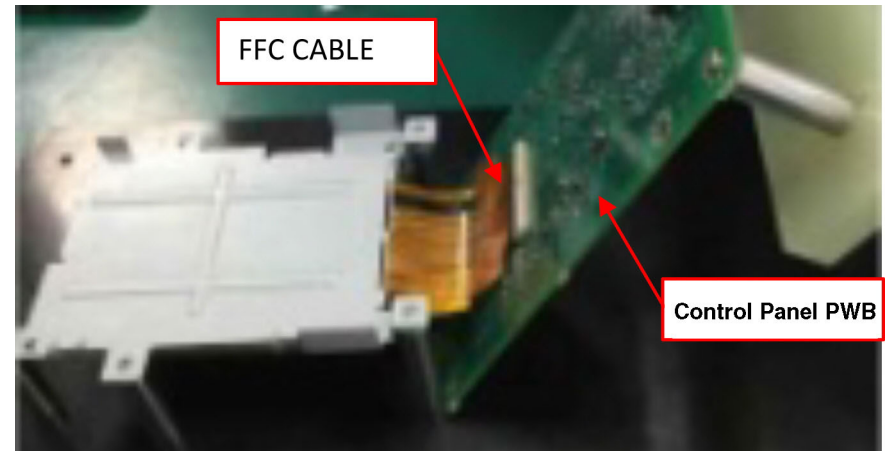

Figure 3 Control Panel PWB removal

### Replacement

The replacement is the reverse of the removal procedure.

## REP 8.5 Home Key / Power Key / LCD Screen (B215)

Parts List on [PL 8.2](#)

### Removal

1. Switch off the printer, then disconnect the power cord.
2. Remove the Control Panel PWB, [REP 8.4](#).
3. Remove the Power Key and Home Key from the control panel Front Cover, [Figure 1](#).

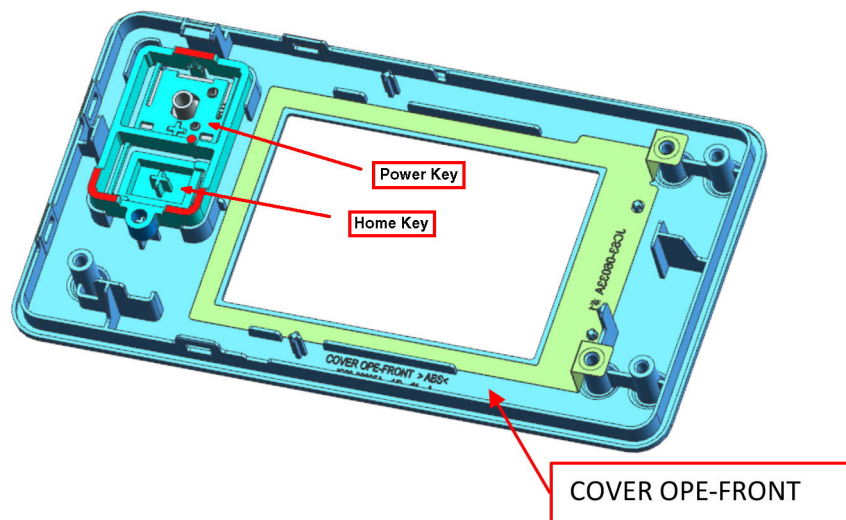

Figure 1 Cover-Stopper removal

N-1-0024-A

4. Carefully separate the LCD Screen from the LCD Plate to remove, [Figure 2](#).

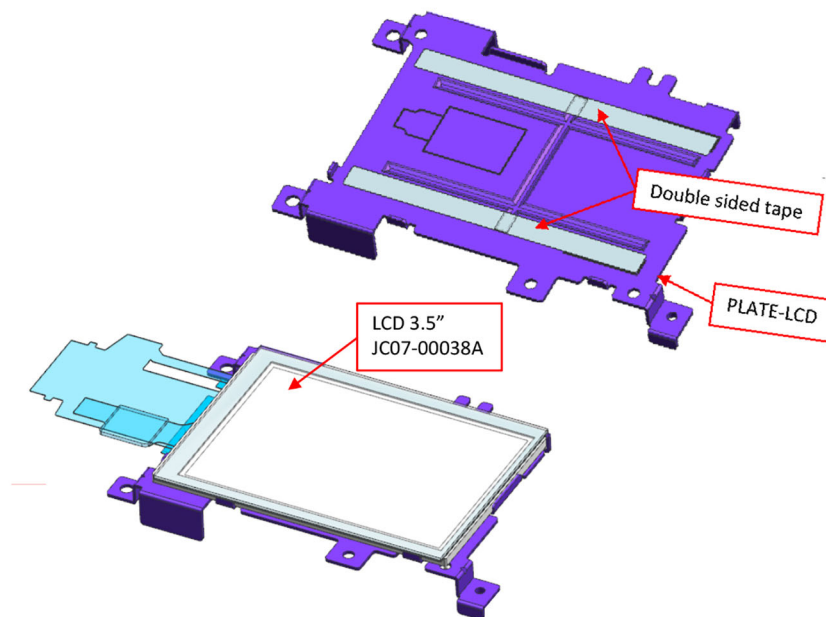
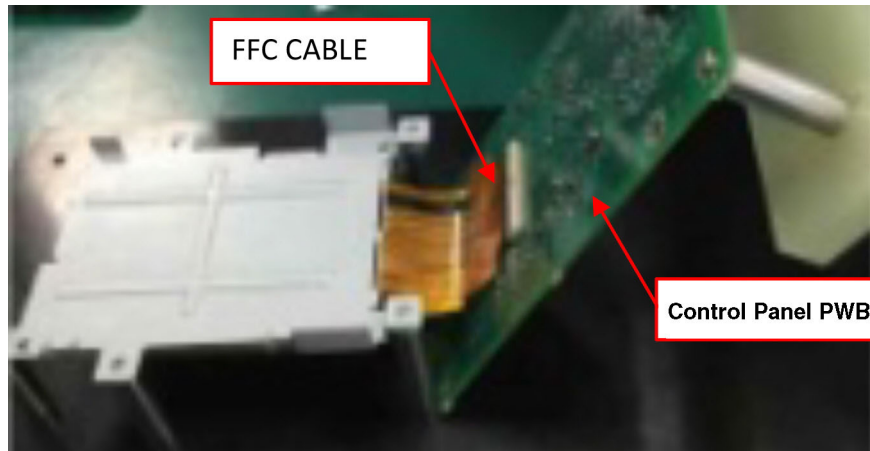

Figure 2 LCD Screen removal

N-1-0035-A

5. Release the Control Panel FFC cable, then remove the Control Panel PWB, [Figure 3](#).



**Figure 3 Control Panel PWB removal**

N-1-0023-A

### **Replacement**

The replacement is the reverse of the removal procedure.



<b>Main</b>	
PL 1.1 Main Overview .....	5-3
<b>ADF</b>	
PL 1.2 ADF .....	5-4
<b>Covers</b>	
PL 2.1 Covers .....	5-5
<b>Middle Cover</b>	
PL 2.2 Middle Cover .....	5-6
<b>Frame</b>	
PL 4.1 Frame .....	5-7
<b>Duplex</b>	
PL 4.2 Duplex Assembly .....	5-8
<b>Exit Frame</b>	
PL 4.3 Exit Frame .....	5-9
<b>Paper Path</b>	
PL 4.4 Paper Path .....	5-10
<b>Base Pick Up</b>	
PL 4.5 Base Pick Up .....	5-11
<b>Left Main Frame</b>	
PL 4.6 Left Main Frame .....	5-12
<b>Right Main Frame</b>	
PL 4.7 Right Main Frame .....	5-13
<b>Fuser</b>	
PL 5.1 Fuser .....	5-14
<b>Lower Fuser</b>	
PL 5.2 Lower Fuser .....	5-15
<b>Cassette</b>	
PL 6.1 Paper Tray .....	5-16
<b>Platen</b>	
PL 7.1 Scanner Module (B205) .....	5-17
PL 7.2 Scanner Module (B215) .....	5-18
<b>Control Panel</b>	
PL 8.1 Control Panel (B205) .....	5-19
PL 8.2 Control Panel (B215) .....	5-20
<b>Part Number Index</b> .....	5-21





## PL 1.1 Main Overview

Item	Part	Description
1	–	Cover
2	–	Paper Tray (PL 6.1)
3	–	Coupling B Lever
4	140N63858	Main PWB (B215) (REP 1.1)*
–	140N63857	Main PWB (B205) (REP 1.1)*
5	–	Fuser (PL 5.1)
6	–	Middle Cover (PL 2.2)
7	–	Control Panel (B205) (PL 8.1) / Control Panel (B215) (PL 8.2)
8	–	Scanner/ADF Assembly (REP 1.2)
9	–	Frame
10	–	Not used
11	–	Scanner Module (B205) (PL 7.1) / Scanner Module (B215) (PL 7.2)
12	050N00680	Document Pad
13	022N02799	ADF Module (PL 1.2) (REP 1.4)
14	003N01117	ADF Hinge (REP 1.3)
15	–	Connector Cover

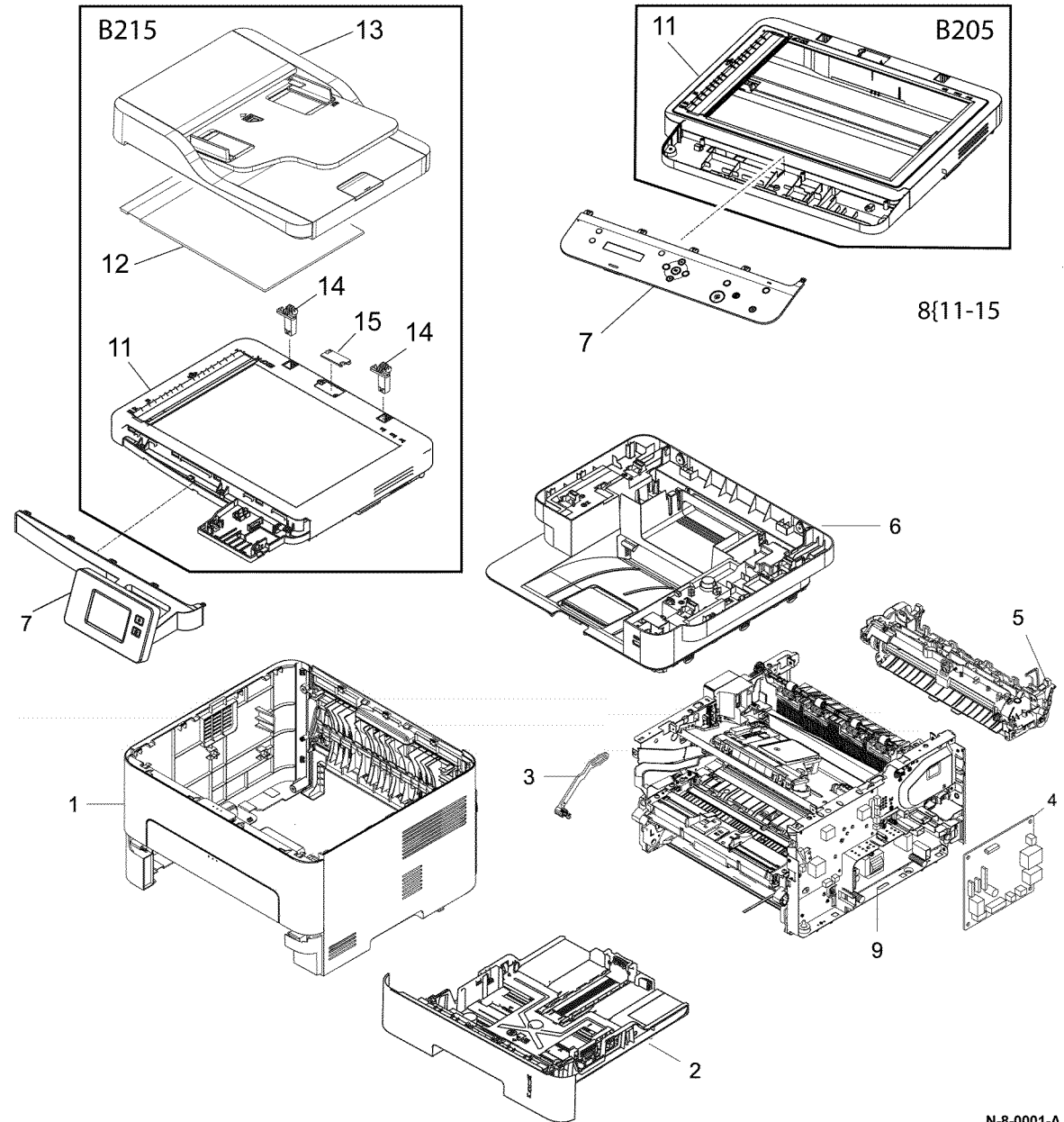

N-8-0001-A

## PL 1.2 ADF

Item	Part	Description
1	022N02801	ADF Feed Roll Assembly (REP 1.5)
2	—	ADF Drive Motor (REP 1.6)
3	022N02800	ADF Retard Pad (REP 1.7)
4	—	Top Cover Sensor
5	—	Paper Present Sensor
6	—	Paper Position Sensor
7	—	ADF PWB (P/O Item 2)

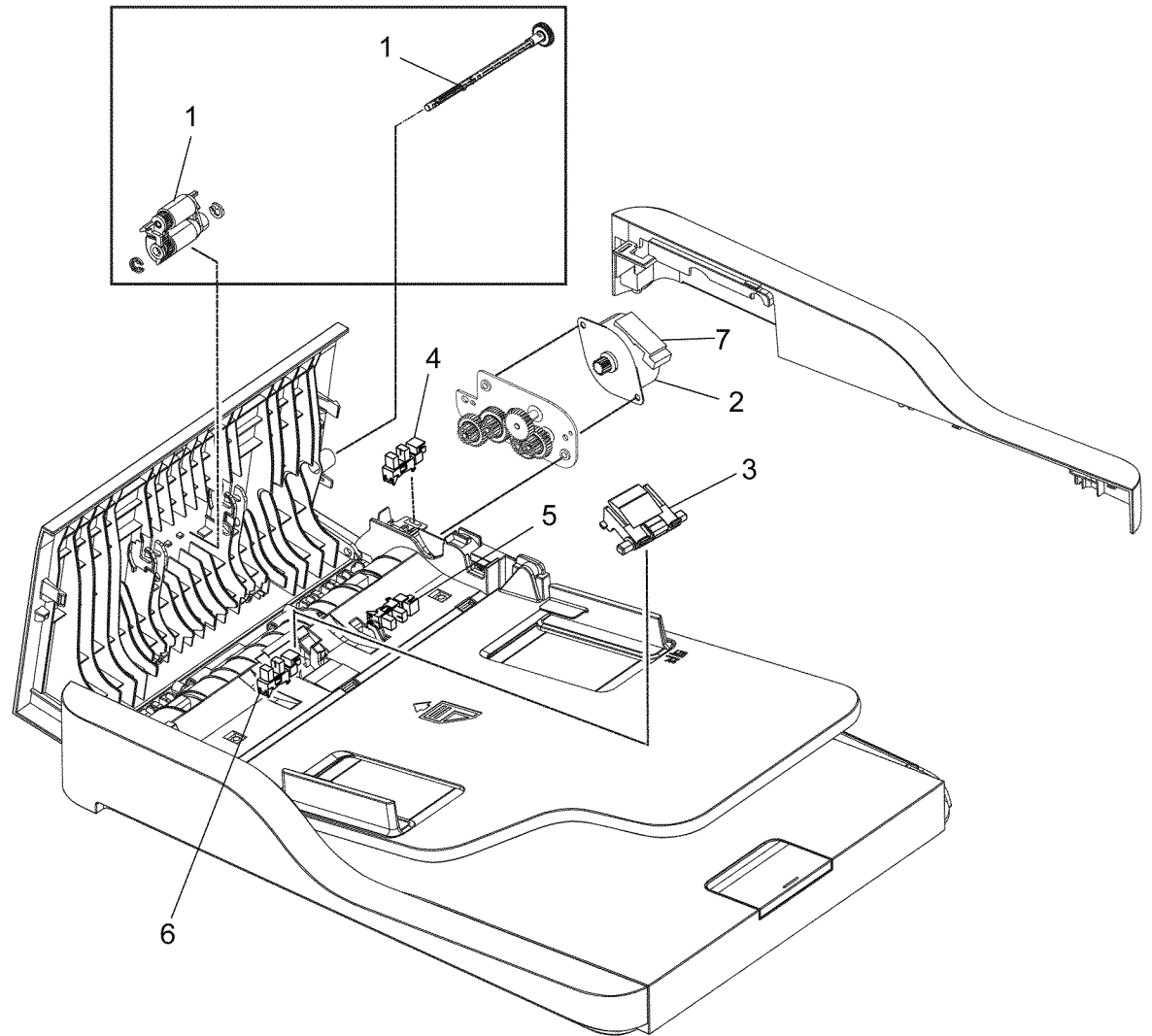

N-8-0002-A

## PL 2.1 Covers

Item	Part	Description	
1	-	Left Cover (REP 2.2)	3 { 5-8
2	-	Right Cover (REP 2.2)	4 { 9-14
3	002N03172	Rear Cover Assembly (REP 2.3)	
4	002N03350	Front Cover Assembly (REP 2.1)	
5	-	Rear Cover (REP 2.3)	
6	-	Exit Paper Guide	
7	-	Duplex Gate	
8	-	Spring	
9	-	Front Cover Latch Sensor	
10	-	CRUM PWB	
11	-	CRUM Contacts	
12	-	Front Cover	
13	-	Manual Feed Cover (REP 2.4)	
14	-	Front Harness Cover	
15	-	CRUM Harness	

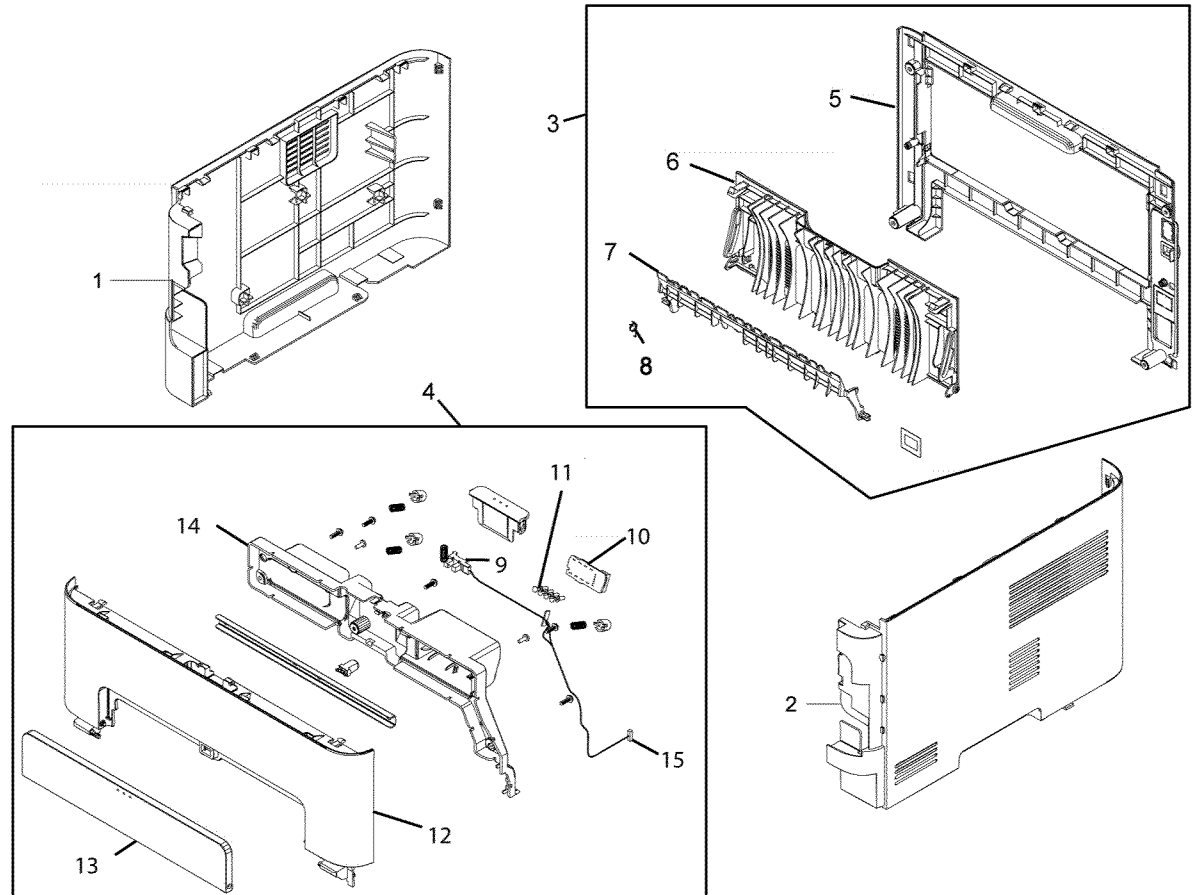

N-8-0003-A

## PL 2.2 Middle Cover

Item	Part	Description
1	–	Left Middle Cover (REP 2.5)
2	–	Right Middle Cover (REP 2.5)
3	140N63863	FAX PWB (B215) (REP 2.6)
4	–	Speaker
5	–	FAX Ground
6	–	Paper Stacker
7	–	Bin Full Sensor Actuator
8	–	Spring
9	–	Output Support
10	–	Antistatic Brush
11	–	Exit Cover
12	–	WNPC (WIFI) PWB (REP 2.7)
13	–	Bracket Holder
14	–	USB Connector
15	–	Middle Cover Assembly

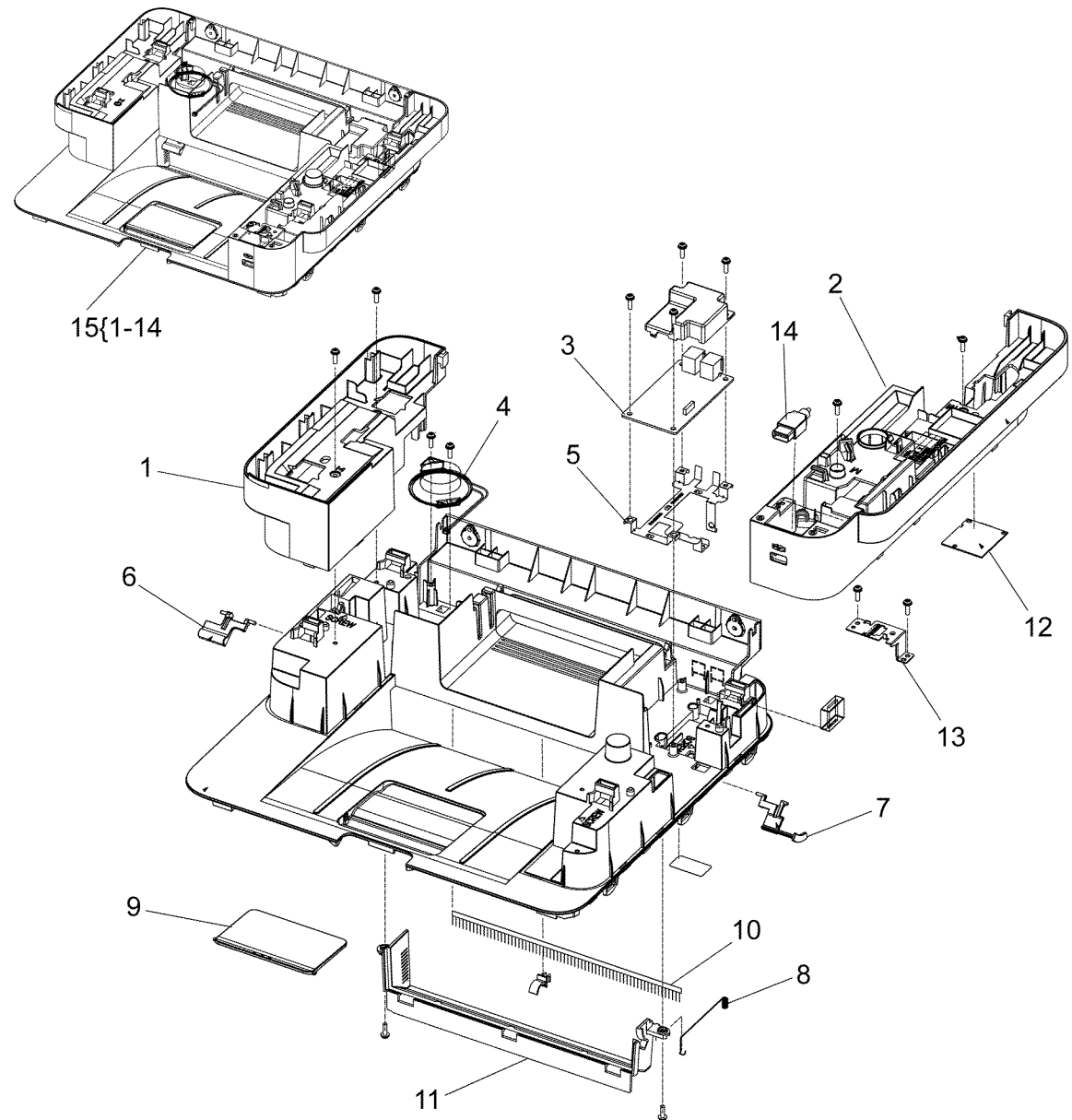

N-8-0004-A

## PL 4.1 Frame

Item	Part	Description
1	117N01969	Flat Cable
2	105N02301	HVPS (REP 4.1)
3	105N02351	LVPS 220V (REP 4.2)
-	105N02350	LVPS 110V (REP 4.2)
4	121N01269	Registration Clutch (REP 4.3)
5	121N01248	Feed Clutch (REP 4.3)
6	-	Transfer Roll Holder
7	-	Bottom Bar
8	-	Feed Frame
9	-	Ground Clip
10	022N02309	Transfer Roller (REP 4.4)
11	-	Exit Gear
12	-	Feed Gear
13	-	Exit Idle Gear
14	-	Exit Gear
15	011N00581	Paper Feed PWB
16	-	Main Exit Frame
17	-	Paper Path Frame
18	-	Exit Sensor Frame
19	-	LSU Bracket Frame
20	-	Left Main Frame
21	-	Right Main Frame
22	062N00292	LSU (REP 4.5)
23	-	Duplex (PL 4.2) (REP 4.6)
24	130N01574	Exit Sensor
25	-	Registration Roll Pivot Gear
26	-	Registration Roll Drive Gear
27	-	Pivot Plate
28	-	Collar

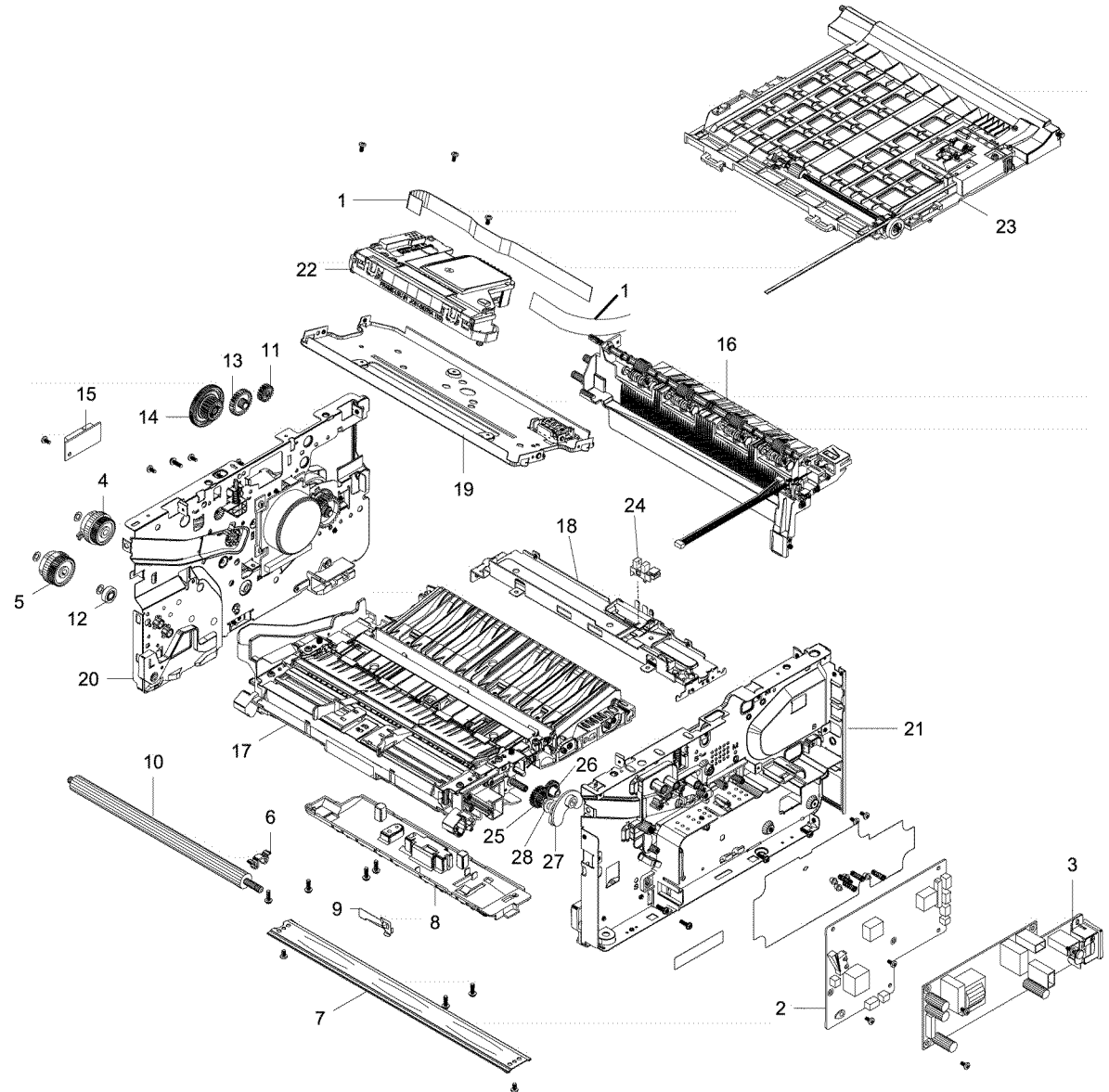

N-8-0005-A





## PL 4.3 Exit Frame

Item	Part	Description
1	130N01574	Output Tray Full Sensor (REP 4.7)
2	-	Harness
3	-	Bushing
4	-	Exit Frame
5	001N00546	Exit Roller (REP 4.8)
6	-	Decurler Roller
7	-	Exit Shaft
8	-	Rubber Exit Dup
9	-	Inner Exit Roller
10	-	Outer Exit Roller
11	-	Exit Roll Holder
12	-	Spring
13	-	Exit Frame Assembly

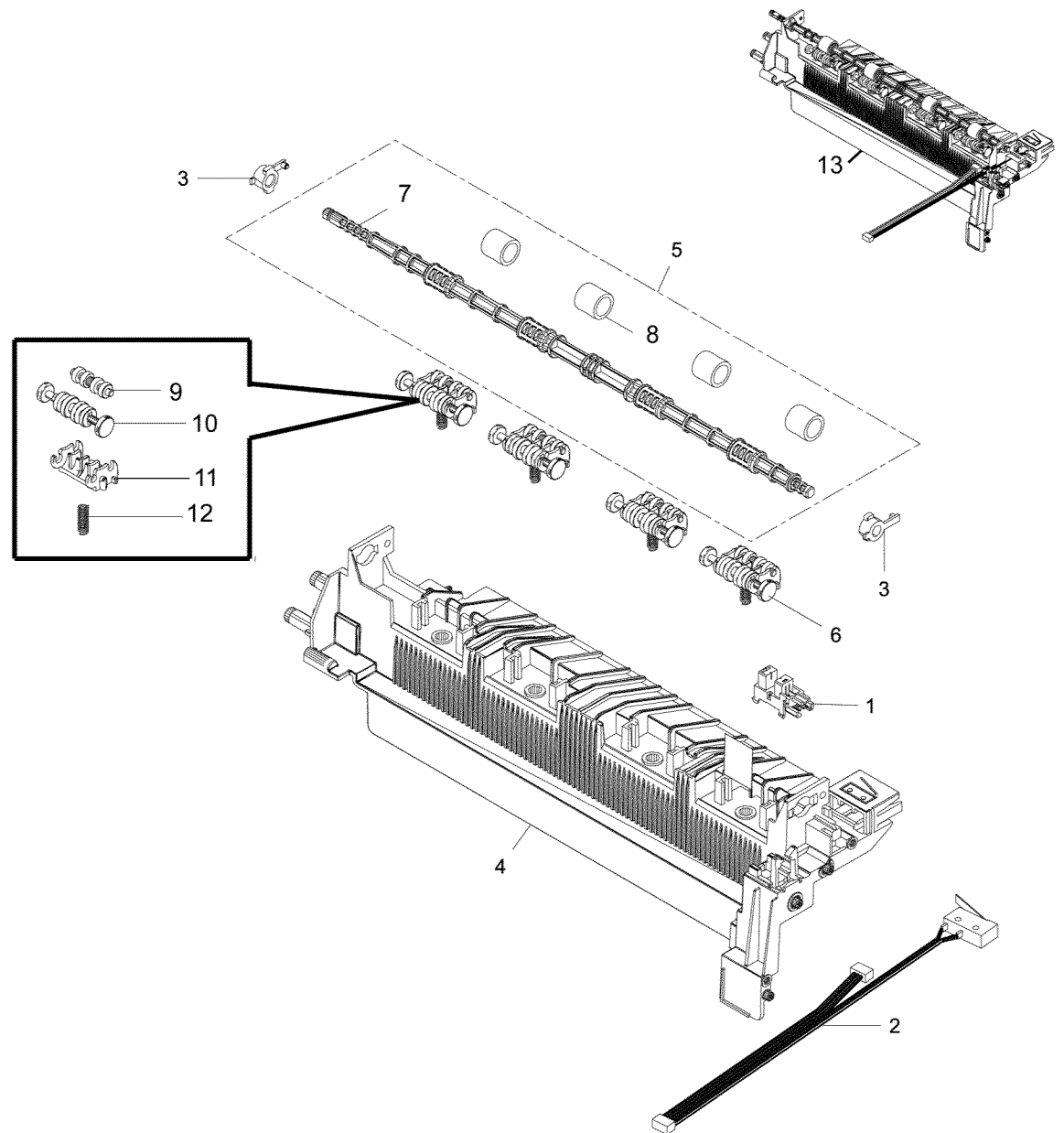

N-8-0007-A

## PL 4.4 Paper Path

Item	Part	Description
1	–	Earth Transfer Plate
2	–	Bushing
3	–	Spring
4	–	Right Push Brush Plate
5	–	Bushing
6	–	Left Push Brush Plate
7	–	Spring
8	–	Spring
9	–	Feed Bushing
10	–	Screw
11	–	Exit Shaft Bushing
12	–	E-Ring
13	022N02797	Registration Roller (REP 4.9)
14	–	Pickup Frame Base
15	–	Middle Frame
16	–	Registration Holder
17	–	P SAW Plate
18	120N00545	Feed Sensor Actuator (REP 4.10)
19	120N00548	Registration Sensor Actuator
20	130N01759	Paper Feed Sensor PWB (REP 4.10)
21	–	Spring
22	–	Registration Base Assembly
23	050N00681	Manual Paper Tray (REP 4.11)
24	–	Paper Guide Cover
25	–	Registration Idle Shaft
26	–	Registration Idle Roller
27	–	Manual Left Adjust
28	–	Manual Right Adjust
29	–	Lower Paper Guide
30	–	Pinion Gear
31	–	Roller Cover
32	–	Pin
33	–	Idle Roller
34	–	Spring
35	–	Sub-Holder Idle

22 { 24 - 26  
23 { 27 - 30  
35 { 31-34

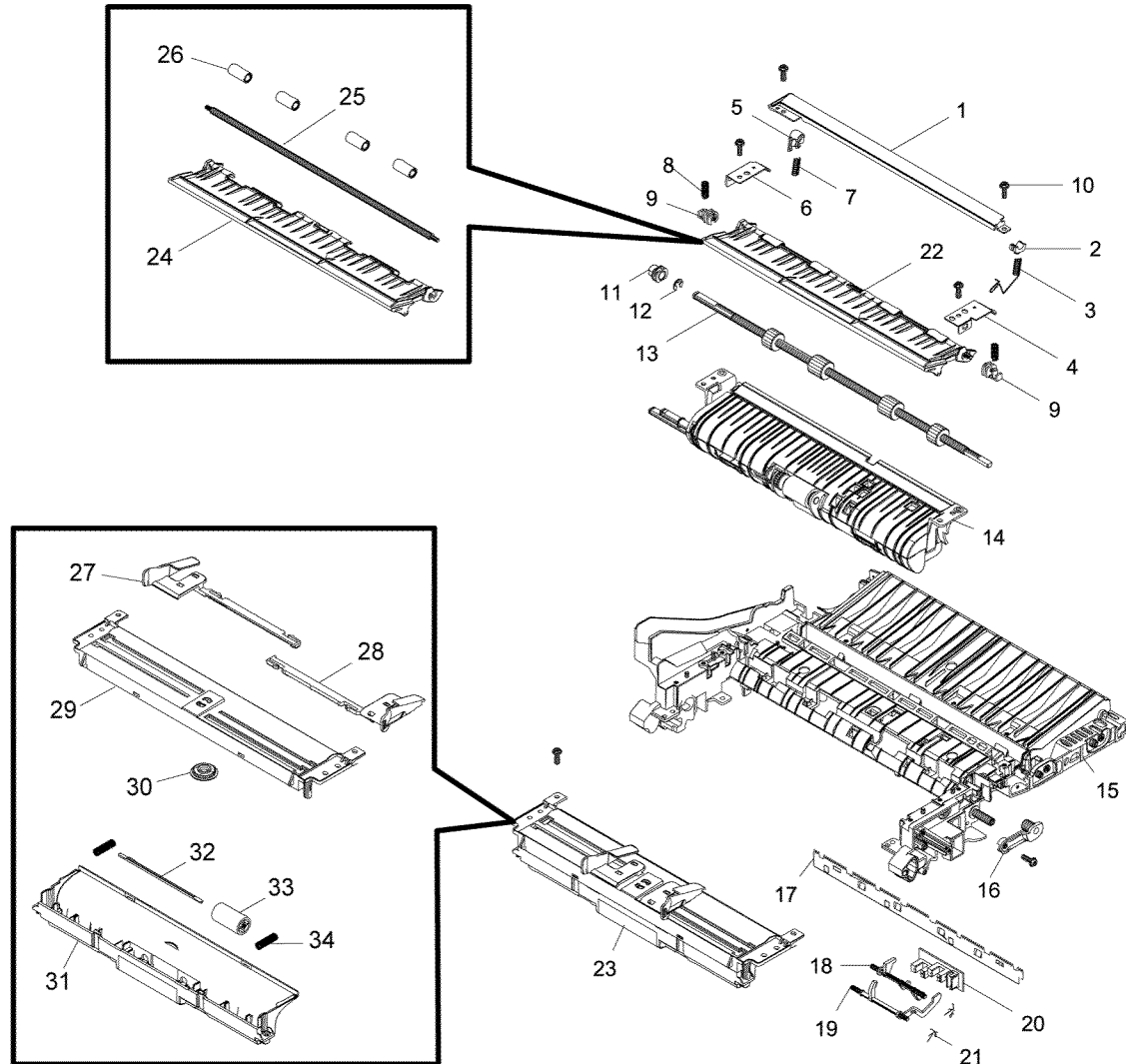

N-8-0008-A

## PL 4.5 Base Pick Up

Item	Part	Description
1	–	Duplex Path Sheet
2	–	Duplex Guide
3	130N01574	Exit Sensor (REP 4.12)
4	–	Spring
5	–	Exit Sensor Actuator
6	–	Duplex Guide Lever
7	–	Pick Up Shaft
8	–	Pick Up Guide
9	022N02802	Paper Drive Roll (REP 4.13)
10	–	Bushing
11	130N01760	Paper Feed Roll Assembly (REP 4.14)
12	–	Feed Roll Holder
13	–	Idle Pick Up Gear
14	–	One Way Clutch
15	–	Retard Roller
16	–	Actuator Empty Holder (REP 4.18)
17	–	Spring TS (REP 4.18)
18	–	Actuator - Width (REP 4.18)
19	–	Actuator - Paper (REP 4.18)
20	–	Feed Sensor PWB (REP 4.18)
21	–	Washer

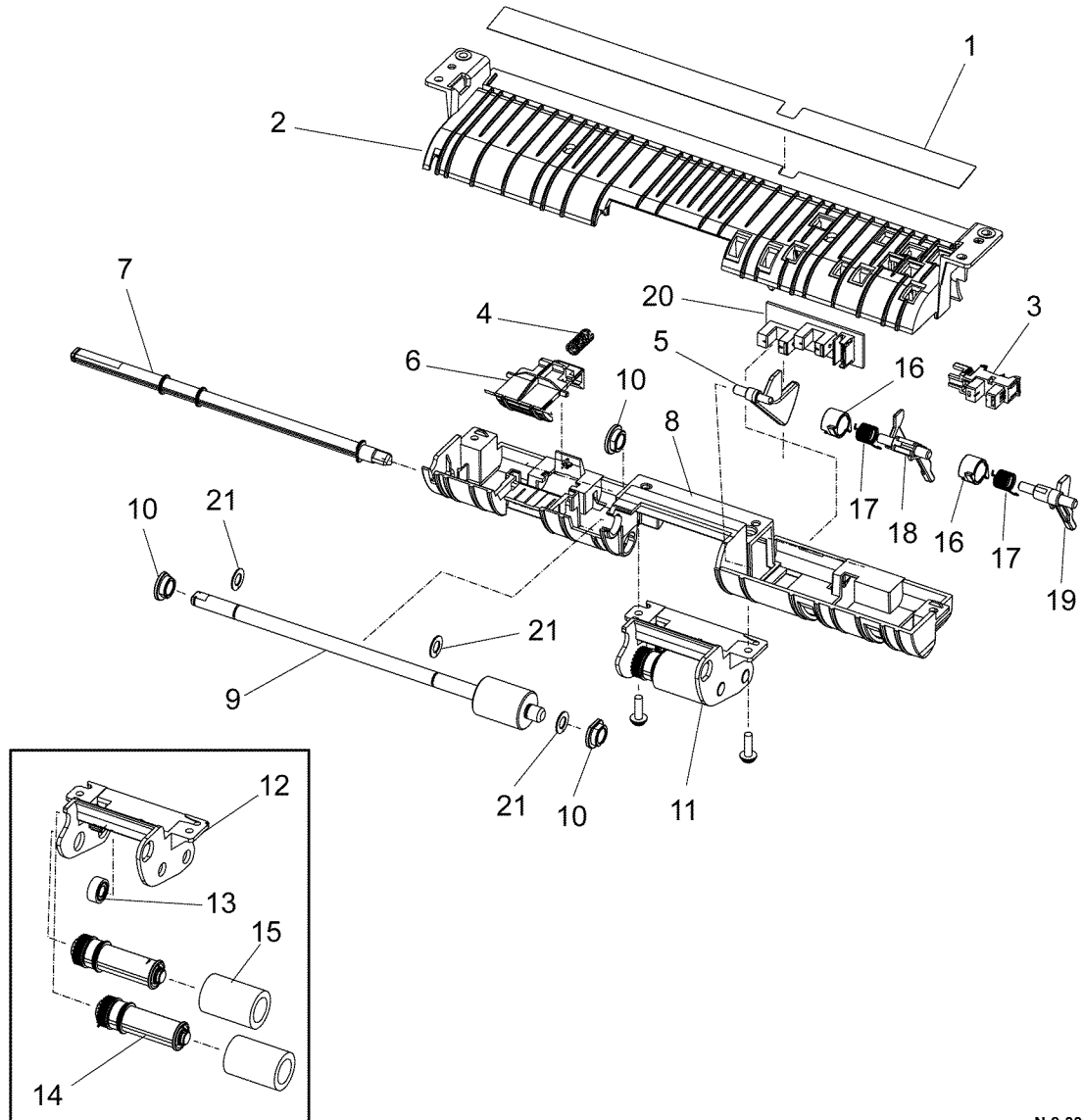

N-8-0009-A

## PL 4.6 Left Main Frame

Item	Part	Description
1	—	Left Rear Guide
2	127N07919	Main Drive Motor (REP 4.15)
3	—	Fuser Drive Out Gear
4	—	Knock Up Left Guide
5	—	Left Developer Guide Plate
6	—	Left Frame
7	—	Shaft Bushing
8	007N01802	Paper Feed Idler Gear (REP 4.16)
9	—	Idler Gear
10	—	Pivot Frame
11	—	Idler Gear
12	—	Fuser Locking Lever
13	—	Hub Clutch Gear
14	—	Feed Gear
15	—	Feed Gear 2
16	—	Cam Coupler
17	—	Coupling Lever
18	007N01842	Main Drive Unit (REP 4.17)
19	—	Harness Cover

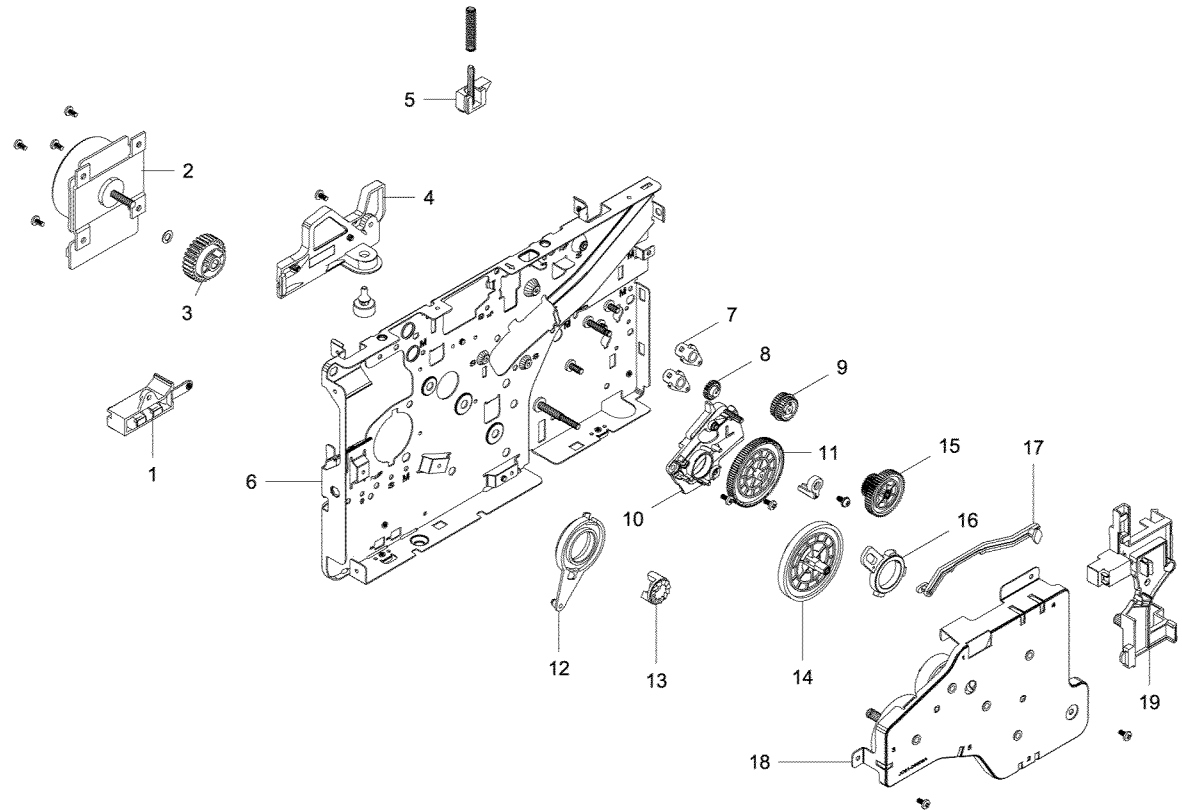

N-8-0010-A

## PL 4.7 Right Main Frame

Item	Part	Description
1	—	Right Developer Guide Plate
2	—	Rear Guide
3	—	Lower Guide
4	—	Foot
5	—	Right Frame
6	—	Cable Clamp
7	—	LVPS Cover
8	—	Developer Right Guide
9	—	Spring
10	—	Ground Clip

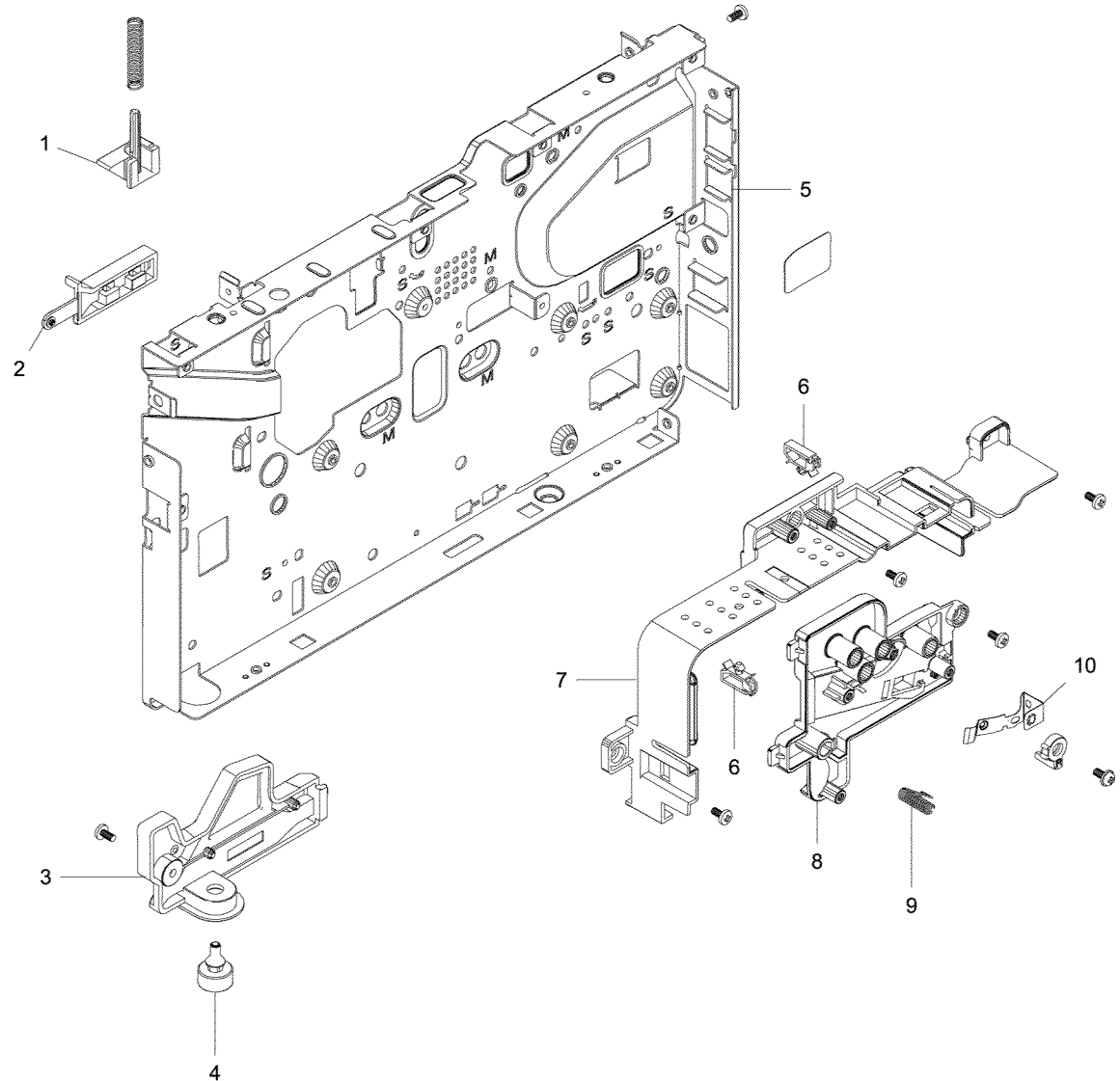

N-8-0011-A



## PL 5.1 Fuser

Item	Part	Description
1	—	Upper Fuser
2	—	Fuser Lamp
3	—	Lower Fuser
4	—	Right Lamp Cap
5	—	Fuser Exit Drive
6	—	Left Lamp Cap
7	—	Fuser Gear Stopper
8	—	Fuser Rear
9	—	Fuser Joint Harness
10	—	Thermostat
11	—	Thermistor
12	—	Fuser Cover
13	—	Exit Roller
14	—	Spring
15	—	Guide
16	—	Spring
17	—	Exit Roller
18	—	Exit Shaft
19	—	Exit Gear
20	—	Bushing
21	—	Rear Guide
22	—	Exit Idle Roller
23	—	Spring
24	—	Actuator Holder
25	—	Exit Sensor Actuator
26	126N00430	Fuser Module 110V (REP 5.1)
—	126N00431	Fuser Module 220V (REP 5.1)

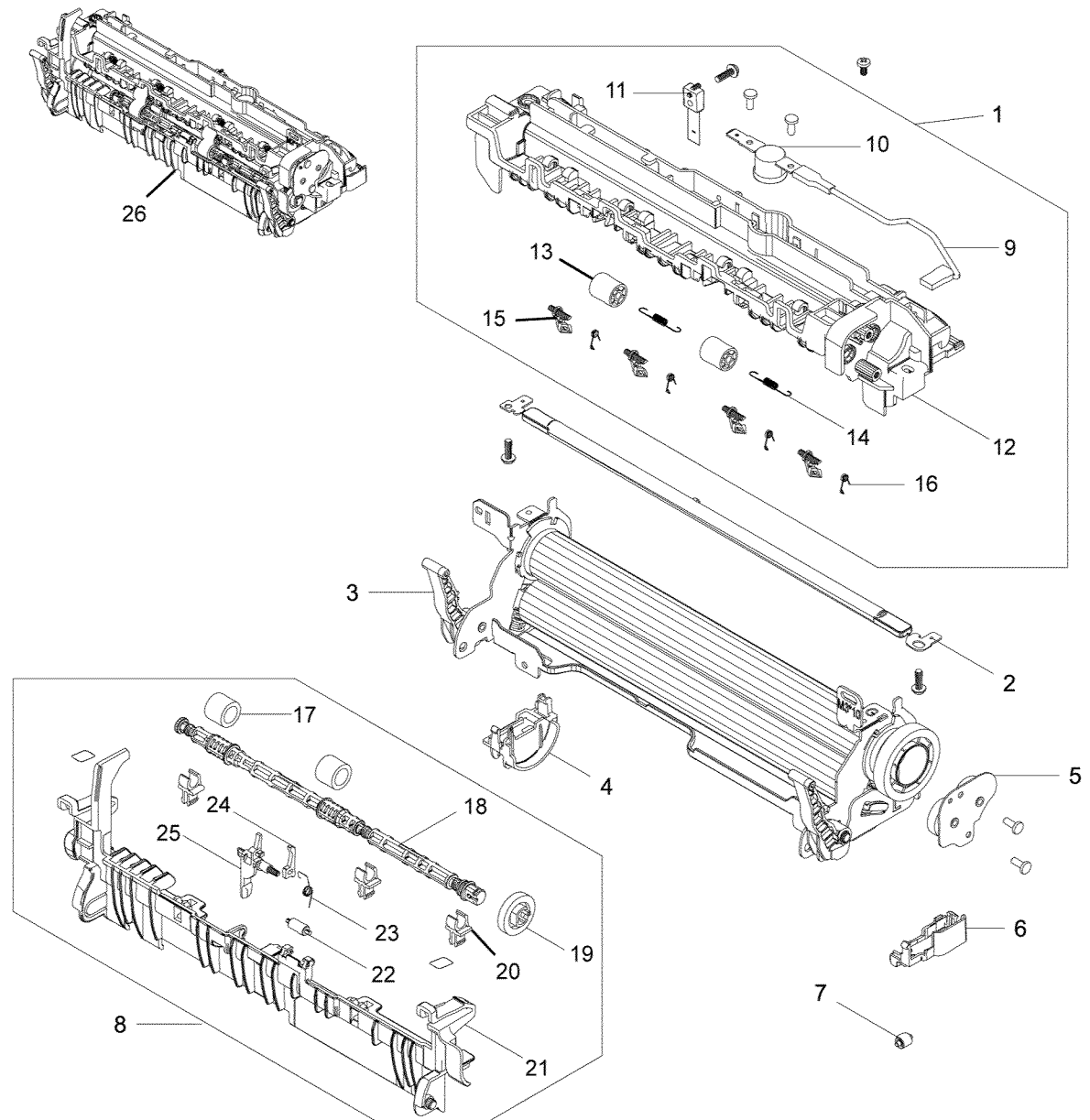

N-8-0012-A

## PL 5.2 Lower Fuser

Item	Part	Description
1	—	Fuser Frame
2	—	Heat Roller
3	—	Left Bushing
4	—	Right Bushing
5	—	Gear
6	—	Roller
7	—	Spring
8	—	Bushing
9	—	Left Jam Lever Link
10	—	Antistatic Brush
11	—	Jam Lever
12	—	Paper Guide Holder
13	—	Lower Fuser Assembly

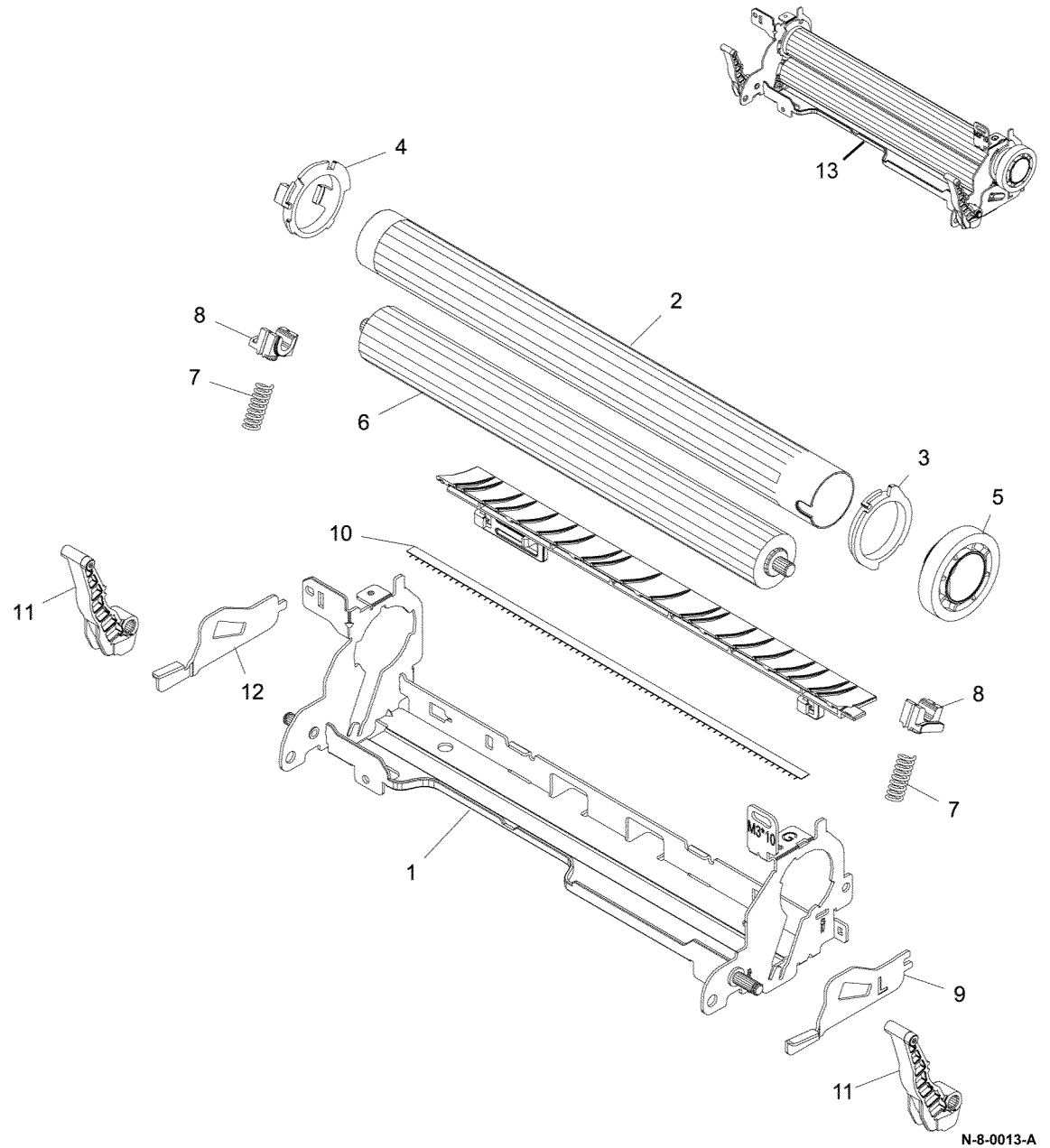

## PL 6.1 Paper Tray

Item	Part	Description
1	—	Lift Plate
2	—	Pad
3	—	Spring
4	—	Pinion Gear
5	—	Retard Roll Cover
6	050N00683	Retard Roll Assembly (REP 6.1)
7	—	Left Paper Guide
8	—	Latch Plate
9	—	Spring
10	—	Paper Tray Latch
11	—	Spring
12	—	Right Paper Guide
13	—	Paper Tray Handle
14	—	Paper Tray Rear Guide
15	—	Paper Tray Frame
16	—	Paper Tray Handle
17	—	Paper Indicator
18	050N00700	Paper Tray

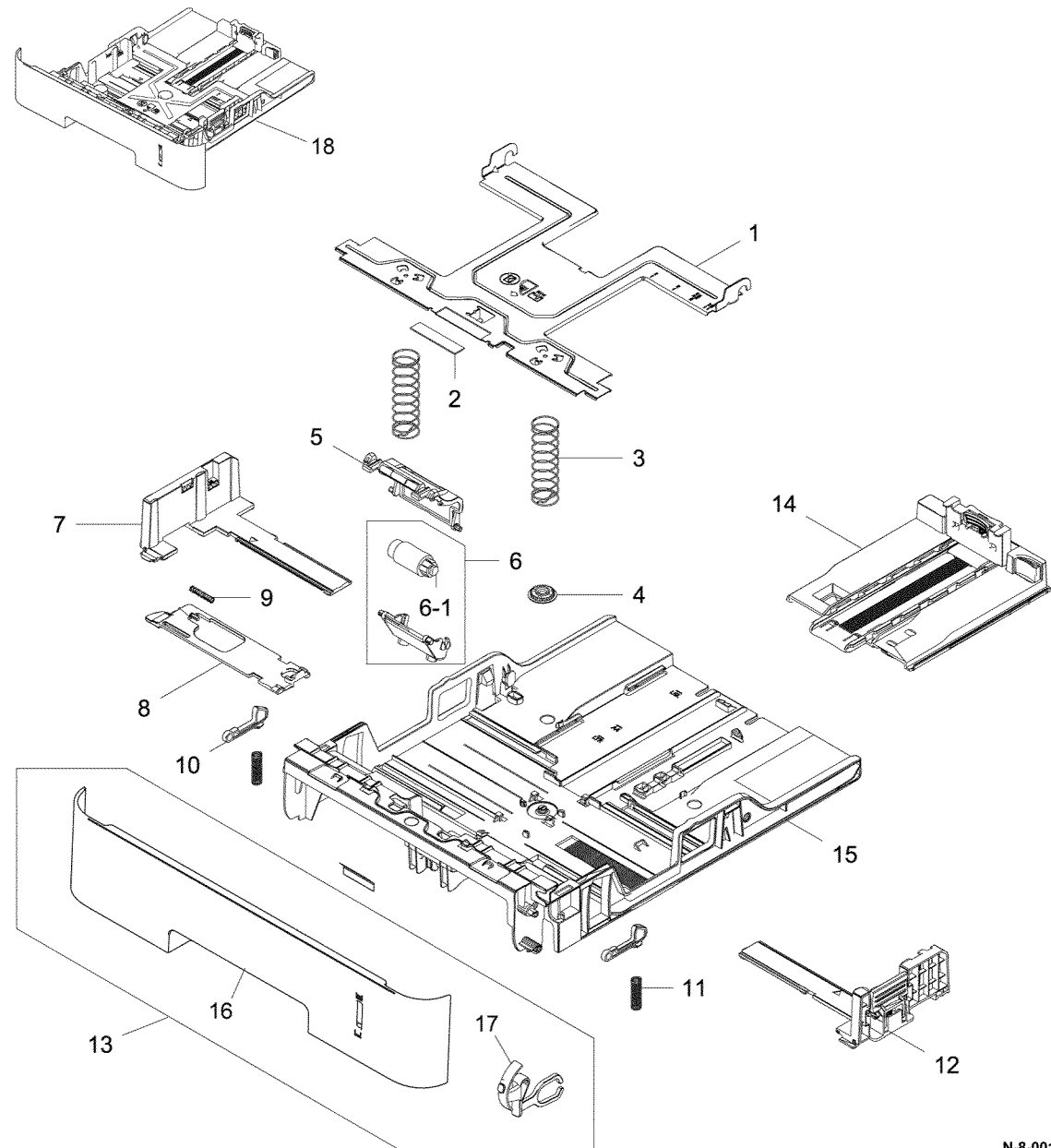

N-8-0014-A

## PL 7.1 Scanner Module (B205)

Item	Part	Description
1	—	Paper Guide
2	—	Upper Scanner Frame
3	—	Lower Scanner Frame
4	—	Contact Image Sensor (CIS)
5	—	Drive Belt
6	—	Scanner Drive Motor
7	—	Connector Bracket (REP 7.1)
8	—	Flat Cable
9	—	Scanner Home Sensor
10	—	CIS Holder
11	—	CIS Guide Shaft
12	090N00182	Scanner Module (REP 7.2)

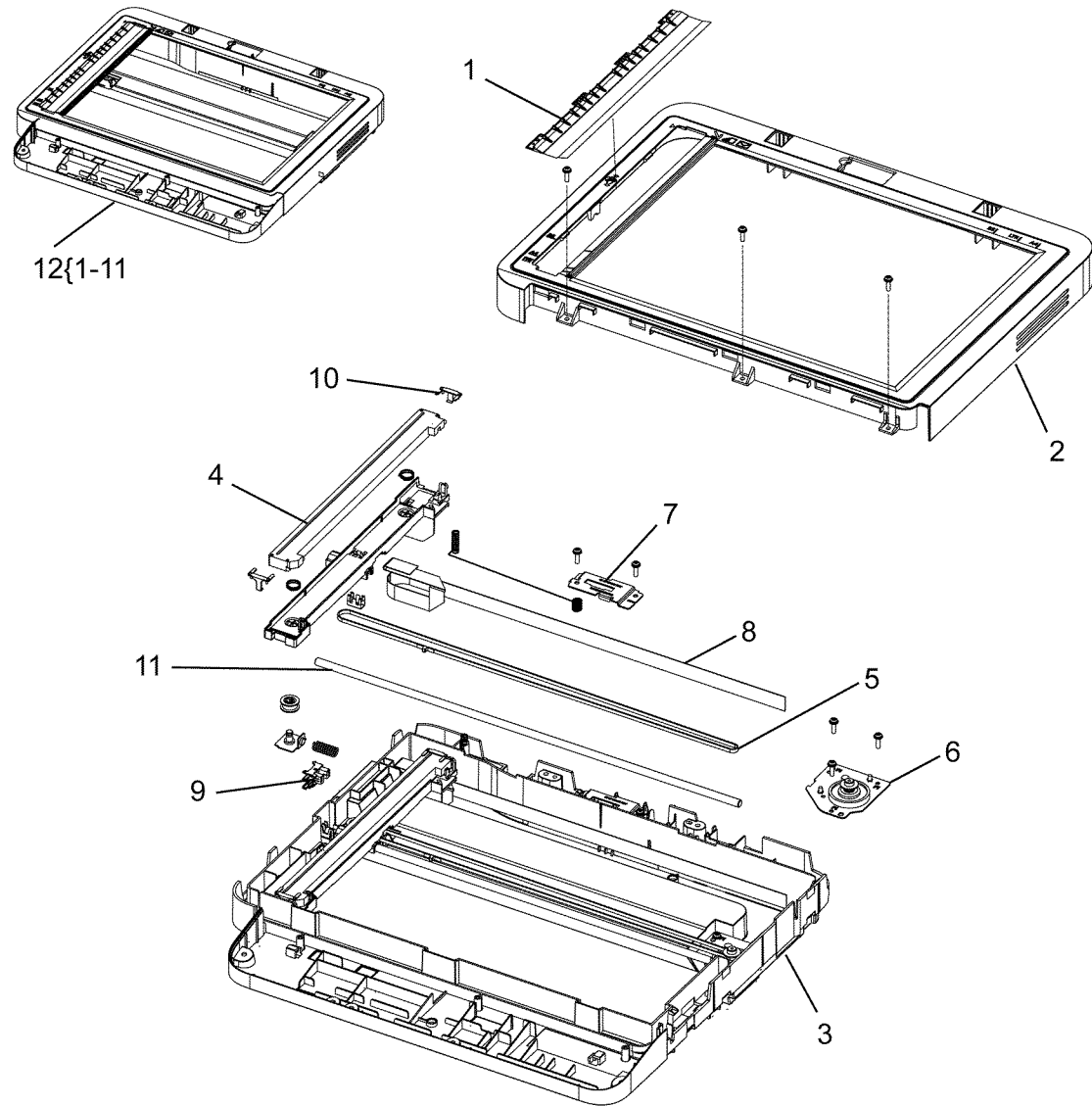

N-8-0015-A

## PL 7.2 Scanner Module (B215)

Item	Part	Description
1	—	Paper Guide
2	—	Upper Scanner Frame
3	—	Lower Scanner Frame
4	—	Contact Image Sensor (CIS)
5	—	Drive Belt
6	—	Scanner Drive Motor
7	—	Connector Bracket (REP 7.1)
8	—	Flat Cable
9	—	Scanner Home Sensor
10	—	CIS Holder
11	—	CIS Guide Shaft
12	—	Front Cover
13	090N00191	Scanner Module (REP 7.2)

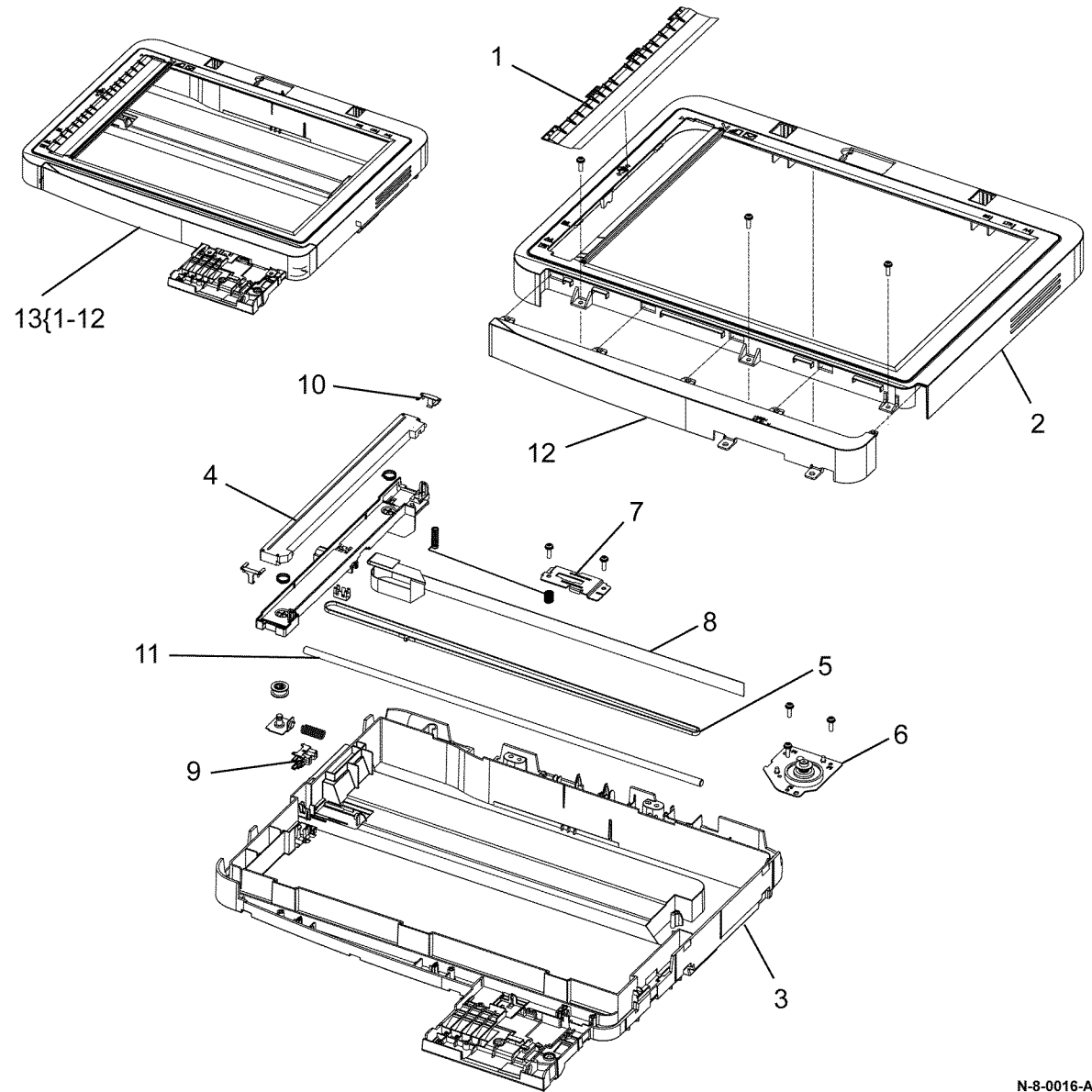

N-8-0016-A

## PL 8.1 Control Panel (B205)

Item	Part	Description
1	–	Top Cover
2	–	Function Keys A
3	–	Function Keys B
4	–	LCU Cover
5	–	Menu Key
6	–	FAX Key
7	140N63724	Control Panel PWB (REP 8.2)
8	–	Power Key (REP 8.5)
9	–	Start Key
10	–	Navigation Keys
11	–	Status Lens
12	–	Clear All Key
13	–	Power Save Key
14	140N63860	Control Panel Assembly (Dup / NW / WiFi) (REP 8.1)

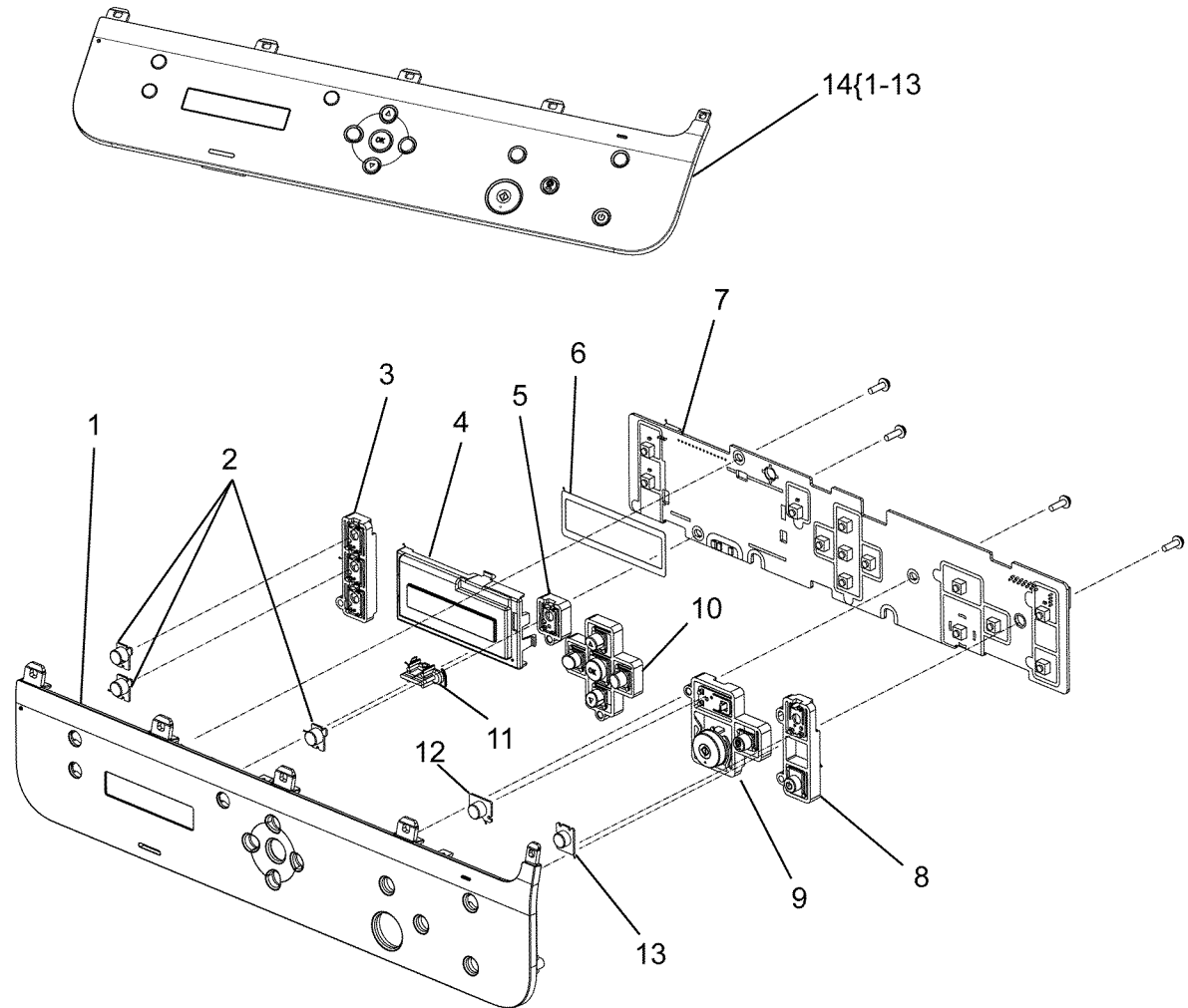

N-8-0017-A



## PL 8.2 Control Panel (B215)

Item	Part	Description
1	—	Front Cover
2	—	Ground Plate
3	—	Seal
4	—	LCD Screen (3.5") (REP 8.5)
5	—	LCD Plate
6	140N63861	Control Panel PWB (REP 8.4)
7	—	Lower Cover
8	—	Hinge Holder
9	—	Damper Link
10	—	Stopper Cover
11	—	Ground Harness
12	—	Home Key (REP 8.5)
13	—	Power Key (REP 8.5)
14	140N63859	Control Panel Assembly (REP 8.3)

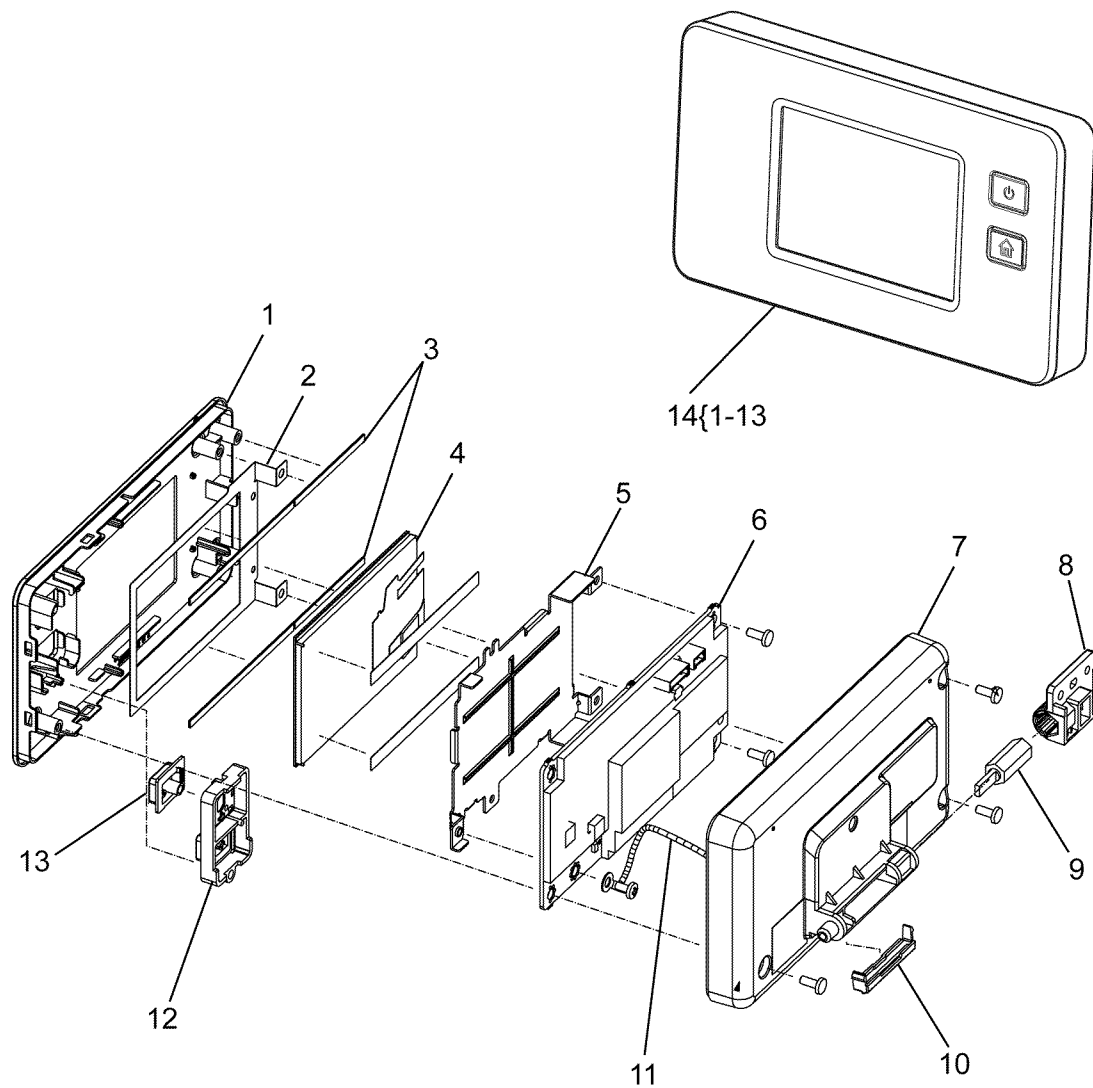

N-8-0018-A

## Part Number Index

Table 1 Part Number Index

Part Number	Part List
001N00546	PL 4.3
002N03172	PL 2.1
002N03350	PL 2.1
003N01117	PL 1.1
007N01802	PL 4.6
007N01842	PL 4.6
011N00581	PL 4.1
022N02309	PL 4.1
022N02797	PL 4.4
022N02799	PL 1.1
022N02800	PL 1.2
022N02801	PL 1.2
022N02802	PL 4.5
022N02815	PL 4.2
050N00680	PL 1.1
050N00681	PL 4.4
050N00683	PL 6.1
050N00700	PL 6.1
062N00292	PL 4.1
090N00182	PL 7.1
090N00191	PL 7.2
105N02301	PL 4.1
105N02350	PL 4.1
105N02351	PL 4.1
117N01969	PL 4.1
120N00545	PL 4.4
120N00548	PL 4.4
121N01248	PL 4.1
121N01269	PL 4.1
126N00430	PL 5.1
126N00431	PL 5.1
127N07919	PL 4.6
130N01574	PL 4.3
130N01574	PL 4.5
130N01574	PL 4.1
130N01759	PL 4.4
130N01760	PL 4.5
140N63724	PL 8.1
140N63857	PL 1.1

Table 1 Part Number Index

Part Number	Part List
140N63858	PL 1.1
140N63859	PL 8.2
140N63860	PL 8.1
140N63861	PL 8.2
140N63862	PL 1.1
140N63863	PL 2.2



---

# 6 General Procedures / Information / Diagnostics

## Information

General Information .....	6-3
System Overview .....	6-3
Product Specifications.....	6-8

## General Procedures

GP 1 Diagnostics Entry and Exit (B215 and B205).....	6-15
GP 2 Machine Counters .....	6-17
GP 3 Machine Firmware Version .....	6-18
GP 4 Machine Settings .....	6-19
GP 5 Altitude Adjustment .....	6-21
GP 6 Machine Reports.....	6-22
GP 7 Firmware Upgrade .....	6-24
GP 8 Usage of the Electrostatic Discharge (ESD) Field Service Kit .....	6-25
GP 9 DC 305 UI Button Test Sequence (B205).....	6-25
GP 10 SA Password Reset.....	6-26

## Diagnostics

Diagnostic Information .....	6-27
EDC MODE - (Diagnostics Mode).....	6-33
Data Setup .....	6-35

## Glossary of Terms

Glossary of Terms.....	6-37
------------------------	------

## Change Tags

Tags/MODs.....	6-39
----------------	------



## General Information

The Xerox® B215/B205 Multifunction Printer uses a single-pass laser design offering simplex speeds of up to 31 ppm and output resolution of up to 1200 x 1200 dpi.

The Xerox® B215 printer features; copy, scan, fax, email and USB device functions. In addition to all of the functions of the B215, the Xerox® B205 and B215 printers include Wi-Fi and Wi-Fi Direct™ as standard components.

## System Overview

This section provides illustrations of the following systems:

- ADF Paper Path - [ADF Paper Path](#)
- Engine Paper Path - [Engine Paper Path](#)
- System Layout - [System Layout](#)
- Print Process - [Print Process](#)
- Laser Scanner Unit (LSU) - [Laser Scanner Unit \(LSU\)](#)
- Drives - [Drives](#)
- Toner System - [Toner System](#)

Some features and options may not be available depending on machine configuration. Refer to the Xerox® B205/B215 User Guide for detailed feature and configuration information.



## ADF Paper Path

The following diagram display the path that the paper follows during the ADF printing process.

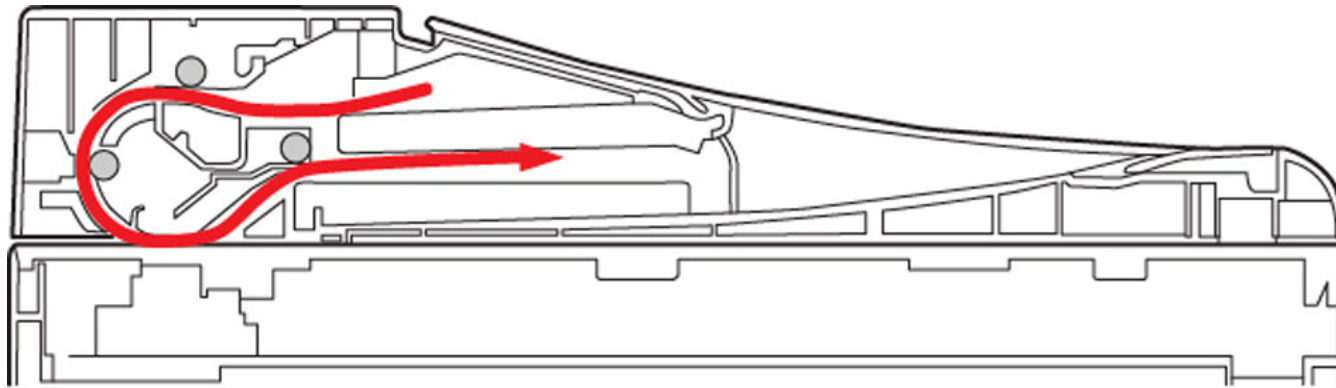

s3215\_3225-001

Figure 1 ADF Paper Path

## Engine Paper Path

The following diagram display the path the paper follows during the engine printing process.

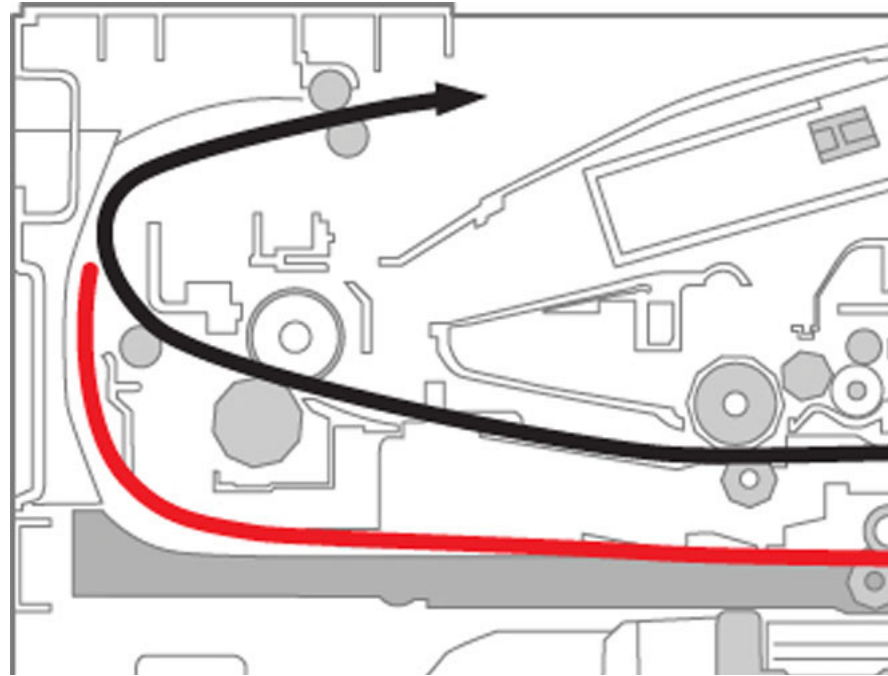

Figure 2 Engine Paper Path

## System Layout

The figures below illustrates the mechanical parts of the scanner and print engine.

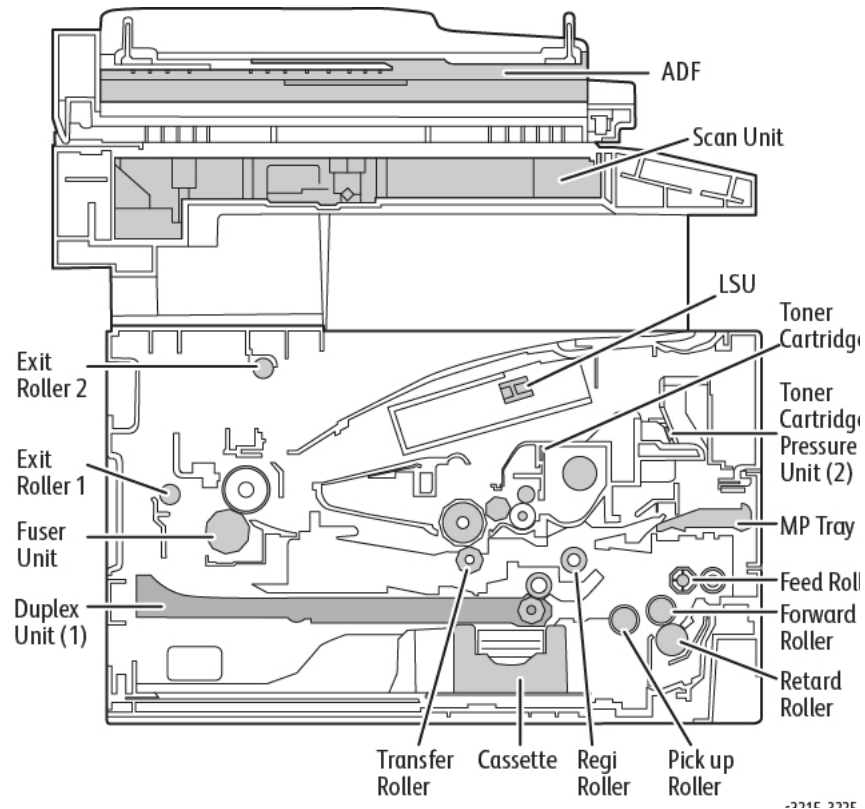

Figure 3 System Layout

## Print Process

Figure 4 presents a general layout of the fusing and printing components used in the print process.

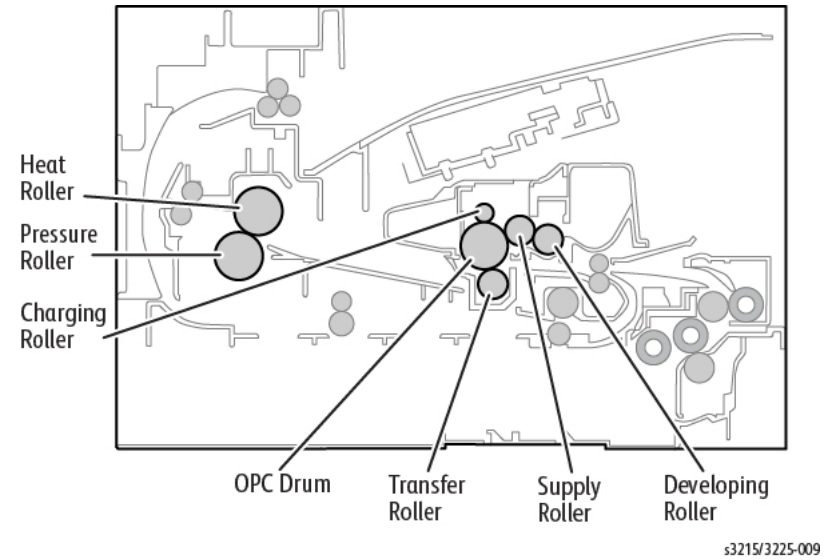
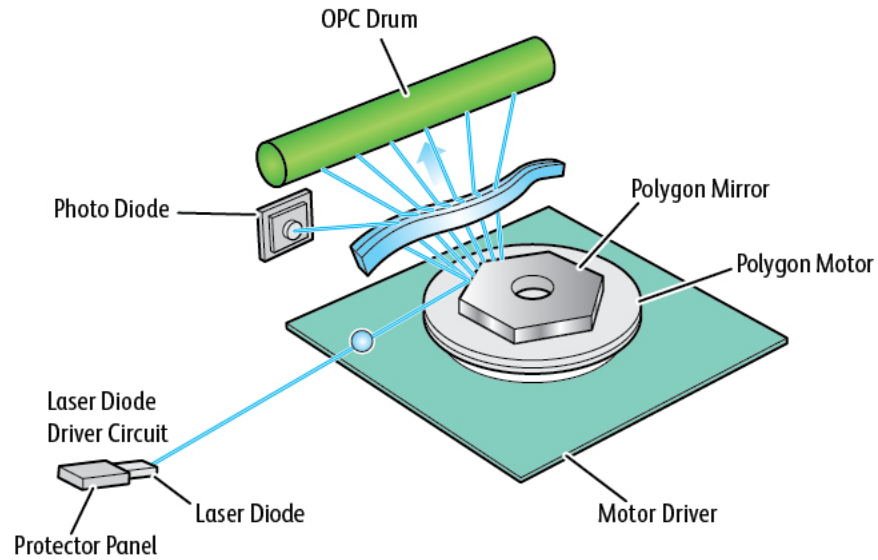

Figure 4 Paper Feed System

## Laser Scanner Unit (LSU)

The Scanner Unit receives image data from the HVPS PWB and scans the surface of the photoreceptor drum (OPC) with a laser to create a latent image.



s3215\_3225-005

Figure 5 Laser Scanner Unit

## Drives

The Drive System consists of the Main (BLDC) Motor, Registration and Pick-up Clutches along with various gears for the Drum Cartridge (OPC), Fuser, Pick-up, Registration, Feed and Exit Rollers.

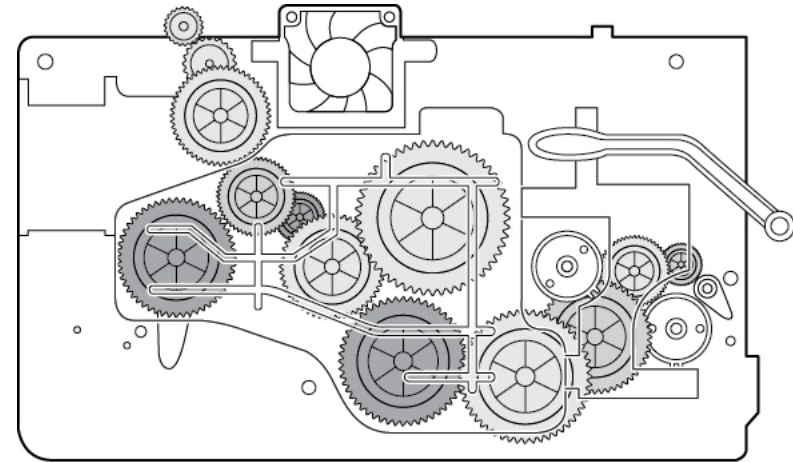

s 3215/3225-004

Figure 6 Drive Gears and Clutches

## Toner System

The printer uses a separated toner system comprised of a Toner Cartridge and Imaging Unit.

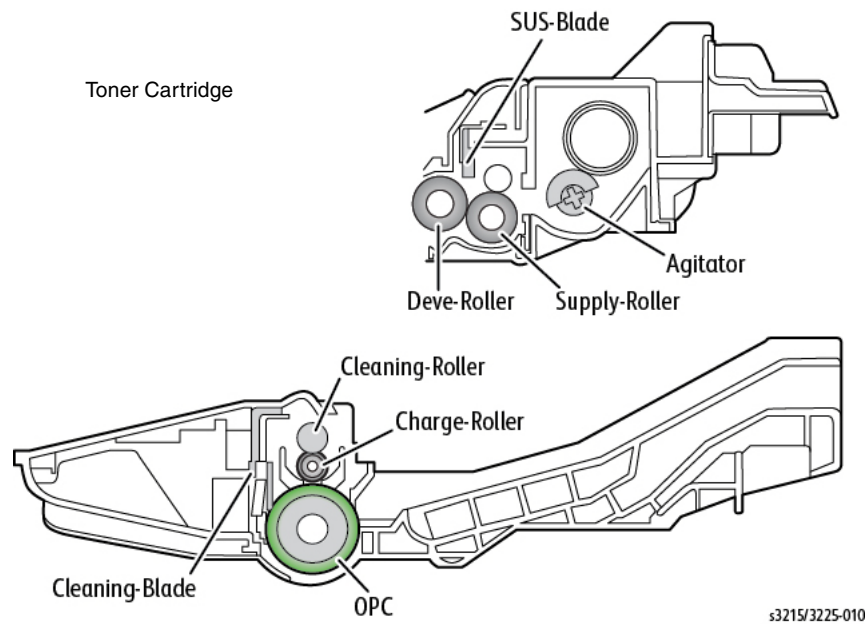

Figure 7 Separated Toner System

## Product Specifications

Table 1 Product Overview

Feature	B205/B215
Speed	31 ppm 8.5 x 11 in. 30 ppm A4 15 ipm Duplex (B215)
Print Resolution - effective output	1200 x 1200 dpi
Processor	600MHz
Printer Language Emulation	SPL, PCL6/5e, PS3
Memory	DDR3 256 MB
Interface	High speed USB 2.0 10/100 BaseTX network connector
Toner and DRUM Cartridge	Refer to <a href="#">Table 8</a> .

Table 2 General Print Engine Specifications

Item	Mode	B205/B215
Warm-up Time	From Sleep Mode	Less than 32 seconds
FPOT	From Sleep Mode	Less than 8.5 seconds
	From Standby	Less than 15 seconds
Resolution		1200 x 1200 dpi

Table 3 Copy Function Specifications

Item		Specification B205 / B215
Copy Speed	SDMC (Text, Text/Photo Mode)	30 cpm (A4) 31 cpm (8.5 x 11 in.)
	MDSC (Text, Text/Mixed Mode)	20 cpm (A4) 21 cpm (8.5 x 11 in.)
FCOT	From Standby	ADF - Less than 15 seconds
		Platen - Less than 14 seconds

**Table 3 Copy Function Specifications**

Item		Specification B205 / B215
Copy Resolution	Text	<ul style="list-style-type: none"> <li>• ADF Scan 600 x 600 dpi (Optical 600 x 300 dpi), Printing: 600 x 600 dpi</li> <li>• Platen Scan: 600 x 600 dpi (Optical 600 x 600 dpi), Printing: 600 x 600 dpi</li> </ul>
	Text/Photo	<ul style="list-style-type: none"> <li>• ADF Scan 600 x 600 dpi (Optical 600 x 300 dpi), Printing: 600 x 600 dpi</li> <li>• Platen Scan: 600 x 600 dpi (Optical 600 x 600 dpi), Printing: 600 x 600 dpi</li> </ul>
	Photo	<ul style="list-style-type: none"> <li>• ADF Scan 600 x 600 dpi (Optical 300 x 300 dpi), Printing: 600 x 600 dpi</li> <li>• Platen Scan: 1200 x 1200 dpi (Optical 300 x 300 dpi), Printing: 1200 x 1200 dpi</li> </ul>
Original Type	Factory Default	Text/Photo
Max Original Size	Document Glass	A4
	Document Feeder (ADF)	Legal (8.5 x 14 in.)
Basic Copy	Multi Copy	1 to 99
	Automatic Paper Selection	No
	Manual Paper Selection	Yes
	Duplex Copy	Yes
	Darkness Control	11 levels
	Magnification	Document ADF: 25% - 400% Document Platen: 25% - 100%

**Table 4 Scan Function Specifications**

Item		Specification B205 / B215
Scan Method		Color CIS cpm
Compatibility		TWAIN, WIA
Color Mode		B/W / Greyscale / Color
Scan Speed	Line art, Halftone (mono)	17 ipm @ 300 dpi
	Gray (mono)	17 ipm @ 300 dpi
	Color	6 ipm @ 300 dpi

**Table 4 Scan Function Specifications**

Item		Specification B205 / B215
Resolution	Optical	1200 x 1200 dpi
	Enhanced	4800 x 4800 dpi
Halftone		256 levels
Scan Size	Max. Document Width	216 mm (8.5 in.)
	Effective Scan Width	208 mm (8.2 in.)
	Max. Document Length	ADF: 356 mm (14 in.) Document Glass: 297 mm (11.7 in.)
	Effective Scan Length	ADF: 328 mm (13.7 in.) Document Glass: 289 mm (11.4 in.)
Scan Depth	Color	24 bits
	Mono	1 bit for Line art and Halftone 8 Bits for Gray scale
ADF	Capacity	40 sheets @ 80 gsm
	Document size	Width: 142 to 216 mm Length: 148 to 356 mm

**Table 5 Fax Function Specifications**

Item		Specification B205 / B215
Compatibility		ITU-T G3, ECM
Communication System		PSTN/PABX
Modem Speed		33.6 Kbps
TX Speed		Approx. 3 sec (Mono/Standard/ECM-MMR, @ ITU-T G3 No.1)
Compression		MH/MR/MMR/JBIG/JPEG
Color Fax		Yes (Tx only)
ECM		Yes
Resolution (mono)	Standard	203 x 98 dpi
	Fine	203 x 196 dpi
	S Fine	300 x 300 dpi

**Table 5 Fax Function Specifications**

Item		Specification B205 / B215
Telephone Features	Handset	Yes (China Only)
	On hook Dial	Yes
	Search	Yes (Phone Book)
	Speed Dial	200 locations
	Group Dial	Group Dial
	TAD I/F	Yes
	Tone/Pulse	Yes (Selectable in Tech Mode)
	Pause	Yes
	Auto Redial	Yes
	Last Number Redial	Yes
	Caller ID	No
	External Phone Interface	Yes

**Table 6 Controller and Software**

Item		Specification B205 / B215
Processor		600 MHz
Memory	Standard	256 MB
	Maximum	256 MB
Printer Languages		PCL6/5e, IBM ProPrinter, EPSON, SPL
Fonts		Windows

**Table 6 Controller and Software**

Item		Specification B205 / B215
Print Driver	Default Driver	B205: SPL
		B215: PCL6
	Install	B205: SPL
		B215: PCL6
	Supporting OS	Windows® 7 ~ 10 (32/64bits) Windows® Server 2008, 2008 R2, 2012, 2012 R2, 2016, 2019
		MAC 10.9 ~ 10.14
	Linux RedHat Enterprise Linux: 5, 6, 7 Fedora 15 ~ 26 OpenSuSE: 11.2, 11.4, 12.1, 12.2, 12.3, 13.1, 13.2, 14.1, 15.2 Ubuntu: 11.10, 12.04, 12.10, 13.04, 13.10, 14.04, 14.10, 15.04, 15.10, 16.04, 16.10, 17.04, 17.10, 18.04, 18.10 SuSE Linux Enterprise Desktop: 10, 11, 12 Debian: 6, 7, 8, 9 Linux Mint: 15, 16, 17, 1	
WHQL	Windows® 7 ~ 10 (32/64bits) Windows® Server 2008, 2008 R2, 2012, 2012 R2, 2016, 2019	
Compatibility	Windows® 7 ~ 10 (32/64bits) Windows® Server 2008, 2008 R2, 2012, 2012 R2, 2016, 2019	



**Table 6 Controller and Software**

Item		Specification B205 / B215
Scan Driver	TWAIN	Yes
	WIA	Yes
	ICDM	Yes
	Supporting OS	Windows® 2000/ XP (32/64bits) Windows® Vista(32/64bits) Windows® 2003 Server (32/64bits) Windows® 2008 Server (32/64bits) Windows® 7 (32/64bits) Windows® 2008 Server R2 (64bits)  Linux RedHat Enterprise Linux WS 4, 5 (32/64 bit) Fedora 4, 5, 6, 7, 8, 9, 10, 11, 12 (32/64 bit) SuSE Linux 10.0, 10.1 (32 bit) OpenSuSE 10.2, 10.3, 11.0, 11.1, 11.2 (32/64 bit) Mandriva 2005, 2006, 2007, 2008, 2009, 2009.1 (32/64 bit) Ubuntu 5.04, 5.10, 6.06, 6.10, 7.04,7.10, 8.04, 8.10,9.04, 9.10(32/64 bit) SuSE Linux Enterprise Desktop 10, 11 (32/64 bit) Debian 4.0, 5.0 (32/64 bit)  Mac OS X 10.4 through 10.6

**Table 6 Controller and Software**

Item		Specification B205 / B215
Wired Network	Protocol	TCP/IP TCP/IPv4/IPv6, HTTP, SNMPv1/v2c/v3, SMTP, IPsec, DNS/WINS, DDNS, DHCP, SSL/TLS, BOOTP, AutoIP, Standard TCP/IP printing, LPR, IPP,UPnP(SSDP),Bonjour,Telnet,WSD,SLP,SetIP  Others HTTPs, IPPs, 802.1x (EAP-MD5,EAP-MSCHAPv2, PEAP,TLS), IPsec
	Supporting OS	Windows® 2000/ XP (32/64bits) Windows® Vista(32/64bits) Windows® 2003 Server (32/64bits) Windows® 2008 Server (32/64bits) Windows® 7 (32/64bits) Windows® 2008 Server R2 (64bits)  Linux RedHat Enterprise Linux WS 4, 5 (32/64 bit) Fedora 4, 5, 6, 7, 8, 9, 10, 11, 12 (32/64 bit) SuSE Linux 10.0, 10.1 (32 bit) OpenSuSE 10.2, 10.3, 11.0, 11.1, 11.2 (32/64 bit) Mandriva 2005, 2006, 2007, 2008, 2009, 2009.1 (32/64 bit) Ubuntu 5.04, 5.10, 6.06, 6.10, 7.04,7.10, 8.04, 8.10,9.04, 9.10(32/64 bit) SuSE Linux Enterprise Desktop 10, 11 (32/64 bit) Debian 4.0, 5.0 (32/64 bit)  Mac OS X 10.4 through 10.6
Wireless Network (B215 only)	Protocol	2.11 b/g/n
	Supporting OS	Same as wired network
Application	Easy Printer Manager	Windows and Macintosh
	Smart Panel	Linux
	Network Management	CentreWare® Internet Services
Interface	Parallel	N/A
	USB	High speed USB 2.0

**Table 7 Paper Handling**

Item		Specification B205 / B215
Standard Capacity		Paper Tray (Cassette) 250 sheets 80gsm Multi Purpose Tray 1 sheet
Maximum Capacity		250 sheets 80gsm
Printing	Minimum media size	8.5 x 14 in. (216 x 356 mm)
	Maximum media size	3.0 x 5.0 in. (76 x 127 mm)
Main Paper Tray	Capacity	250 sheets 80gsm
	Media sizes	8.5 x 14 in. (legal) 8.5 x 11 in. (A4), 5.5 x 8.5 in. (A5), ISO B5, JIS B5, Executive, Oficio, Folio
	Media type	Plain, Lightweight, Recycled, Heavy-weight, Archive
	Media weight	16 to 58 lb (60 to 216 gsm)
	Sensing	No
Manual Feed Slot	Capacity	Plain paper and envelope 1 sheet (80 gsm)
	Media sizes	8.5 x 14 in. (legal) 8.5 x 11 in. (A4), 5.5 x 8.5 in. (A5), A6, EXEC, ISO B5, JIS B5, Oficio, Folio, Envelope (No 10, Monarch, DL, C5, C6) Postcard 4x6, Custom
	Media type	Plain, Heavy-weight, Light-weight, Cotton, Colored, Pre-printed, Recycled, Envelope, Transparency, Label, Cardstock, Bond, Archive
	Media weight	16 to 58 lb (60 to 216 gsm)
	Sensing	No
Output Tray Full sensing		Yes
Optional Cassette Tray		N/A
Output Tray stacking capacity		Face-down: 120 sheets (80 gsm) Face-up: 1 sheet
Duplex (B215 only)	Supporting	Yes (Built-in)
	Media sizes	8.5 x 14 in. (legal) 8.5 x 11 in. (A4), 5.5 x 8.5 in. (A5), A6, ISO B5, JIS B5, Executive, Oficio, Folio, Custom
	Media types	Plain, Light-weight, Recycled, Heavy-weight, Archive
	Media weight	16 to 28 lb (60 to 105 gsm)
Non-printable Area	Envelope	0.4 in (10 mm) from edge
	Other media	0.16 in (4 mm) from edge

**Table 8 Toner Cartridge/Print Cartridge**

Machine Model	Item	
B215/B205	Toner Cartridge - Starter	1k images (110VAC) 1.5k images (220VAC)
	Toner Cartridge - Standard 106R04346 (NA/XE) CRU	1.5k images
	Toner Cartridge - High Yield 106R04347 (NA/XE) CRU	3k images
	Toner Cartridge DMO - 106R04348 CRU 2 pk. - 106R04349 CRU	3k images 3k images ea. 6k images total
	Drum Cartridge (Imaging Unit) 101R00664 CRU	10k images

**NOTE:**

Declared yield value in accordance with ISO/IEC 19752.

Depending on the options and job mode used, the toner cartridge's life span may differ.

When replacing a Toner/Print Cartridge, check model number and consumables code. Refer to the Xerox® B215/B205 User Guide for information regarding ordering consumables.

**Table 9 Reliability and Service**

Item	Specification B205 / B215
Printing Volume (SET AMPV)	250 - 400 pages
Maximum Monthly Duty	12,000 pages
MPBF	30,000 pages
MTTR	30 minutes
SET Life Cycle	100,000 pages or 5 years (whichever comes first)

**Table 10 Environment**

Item		Specification B205 / B215
Operating Environment	Temperature	50 - 90 F (10C to 32C)
	Humidity	20% - 80%
Acoustic Noise Level (Sound Power/Pressure)	Print	Less than 50 dB
	Standby	Less than 30 dB
	Sleep Mode	Back Ground Level
Power Consumption	Print	500 W
	Standby	55 W
	Sleep Mode	1.4 W
	Power Off	0.2 W When Wi-fi Direct Mode off, 1.6 W
Dimension (W x D x H)	SET	15.8 x 14.25 x 14.4 in. (401 x 362 x 365.1 mm)

**Table 10 Environment**

<b>Item</b>		<b>Specification B205 / B215</b>
Weight (SET with Toner Cartridge)	Net Weight	24.54 lbs (11.13 Kg)
	Gross Weight	28.48 lbs.(12.92 Kg)



## GP 1 Diagnostics Entry and Exit (B215 and B205)

### Purpose

This procedure describes the following items:

- How to enter Diagnostics Mode.
- How to exit Diagnostics.

For detailed information on Diagnostics Mode menu items, refer to Diagnostic Information in the Diagnostics section of this service manual.

### Procedure - B215 Diagnostics Mode Entry

Diagnostics entry for the B215 Multifunctional Printer:

1. Press and hold the **Home Button** on the control panel for at least 5 seconds until the Password screen appears, [Figure 1](#).

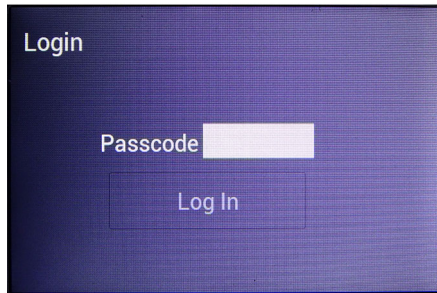

N-1-6051-A

Figure 1 Password screen

2. Touch the box next to Passcode to open the keypad, [Figure 2](#).

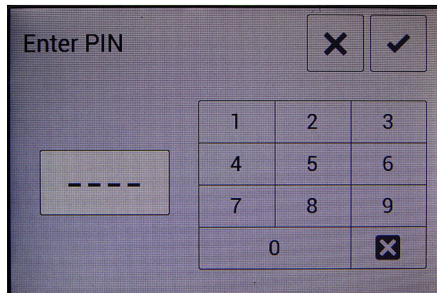

N-1-6052-A

Figure 2 Keypad screen

3. Enter the numbers [1934] as the password, then touch [Log In], [Figure 3](#).

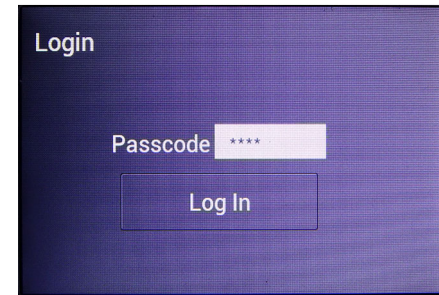

N-1-6053-A

Figure 3 Password displayed screen

4. The Diagnostic Entry screen appears, [Figure 4](#).

The following options are available:

- Data Setup
- Machine Test
- Report
- Exit Diagnostics

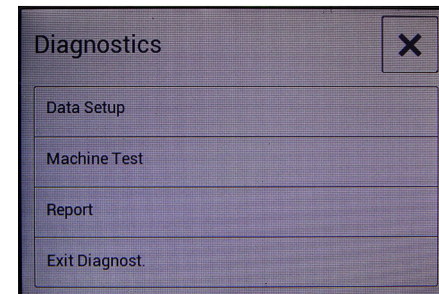

N-1-6054-A

Figure 4 Diagnostics entry screen

**NOTE:** For detailed information on Diagnostics Mode menu items, refer to [Diagnostic Information](#).

#### Exit Diagnostic Mode:

1. Press the **<Back/Exit>** button on the top right of the screen, the Exit screen appears, [Figure 5](#).

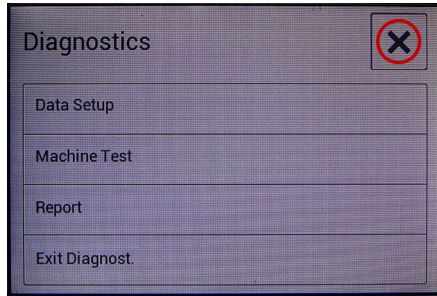

N-1-6105-A

Figure 5 Back to Exit screen

2. Select **<Yes>** to exit diagnostics and reboot the machine or **<No>** to exit Diagnostics only, [Figure 6](#).

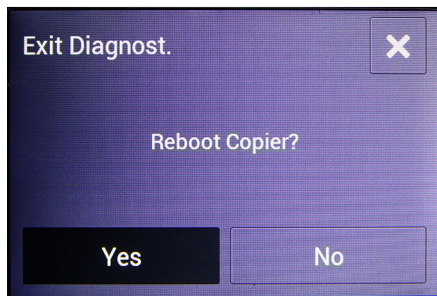

N-1-6082-A

Figure 6 Exit Diagnostics

#### Procedure - B205 Diagnostics Mode (Tech Mode) Entry

Diagnostics entry for the B205:

1. On the B205 at the **<Ready>** screen, press in quick succession the keys: **Menu, Back, Up, Down, OK, Stop, Menu** to enter Diagnostics Mode.
2. At the **[Tech Mode]** screen, select **[OK]**.
3. Press the **<Up>** or **<Down>** keys to scroll through the Diagnostics menu.
4. Press the **<Ok>** key, the following options are available:
  - Data Setup
  - Machine Test
  - Report
  - Exit Diagnostics

#### Exit Diagnostic Mode:

1. With **[Tech Mode]** on the top line of the display, press **<Down>** until **[Exit Diag.]** appears. Select **[OK]**.
2. At **[Exit Diag. ?]** screen, select **[OK]**.
3. At **[Reboot Now?]** screen, using **<Up>** or **<Down>** to choose whether to reboot the device; select **[OK]**.

Refer to Section 6, [Diagnostic Information](#) for a listing of available functions within Diagnostics Mode.

#### NOTE: Be Advised:

- After 30 seconds of inactivity, the selected diagnostics menu will time out and revert back to the level to select Tech Mode or User Mode again.
- After 2 minutes of inactivity, the device will completely exit out of diagnostics



## GP 2 Machine Counters

### Purpose

Use this procedure to access the Machine Counters.

**NOTE:** If frequent paper jams or printing problems are occurring, check the number of pages the machine has printed or scanned. Replace worn parts if necessary.

### Procedure (B215)

1. At the Home screen touch **[Device]**, [Figure 1](#).

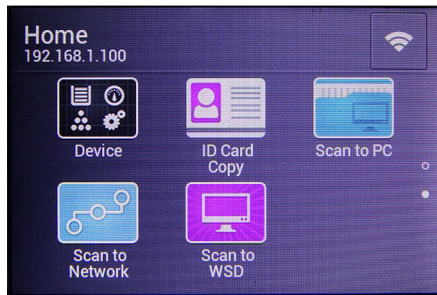

N-1-6050-A

Figure 1 Supplies entry screen

2. Touch **[Supplies]**, [Figure 2](#).

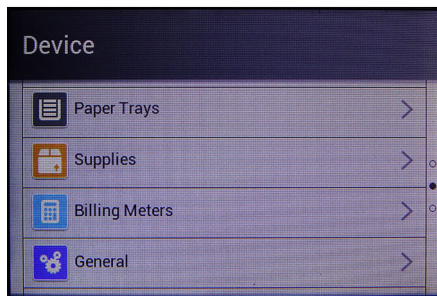

N-1-6084-A

Figure 2 Supplies usage screen

3. The supplies usage and HFSI counters are displayed on the screen, [Figure 3](#).

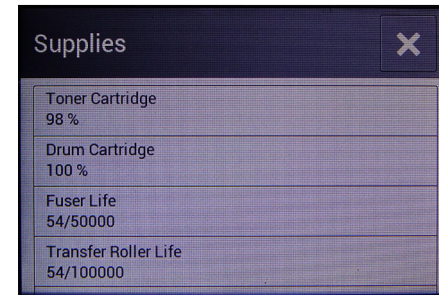

N-1-6095-A

Figure 3 Supplies usage screen 1

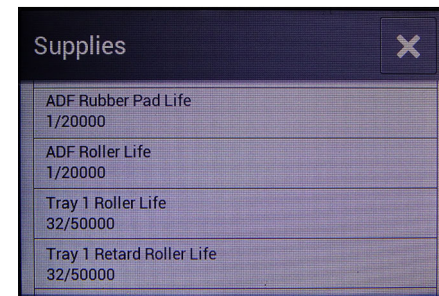

N-1-6096-A

Figure 4 Supplies usage screen 2

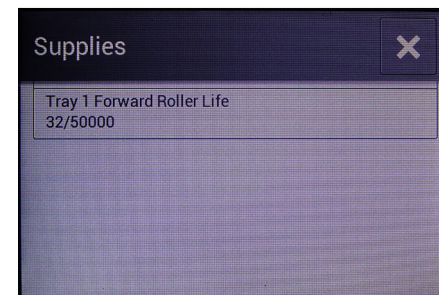

N-1-6097-A

Figure 5 Supplies usage screen 3

**NOTE:** For more options to report printing, refer to [GP 6](#), Machine Reports.



## Procedure (B205)

From the Control Panel:

1. Press the <Information> button
  2. Use the up/down arrows to scroll to <Info Pages>, then press the <OK> button.
  3. Scroll to <Usage Counter> then press the <OK> button to print a Usage Counter report.
- or
1. Enter Diagnostics Mode, select <Diagnostics> then press the <OK> button
  2. Use the up/down arrows to select <Report>, then press <OK>.
  3. Use the up/down arrows to select <Usage Counter>, then press <OK>, then <OK> again to print a Usage Counter report.

## GP 3 Machine Firmware Version

### Purpose

Use this procedure to check the firmware version of the machine.

### Procedure (B215)

1. At the Home screen touch [Device > About > General], Figure 1.  
The Firmware Version is listed as [Software Version] on the screen.

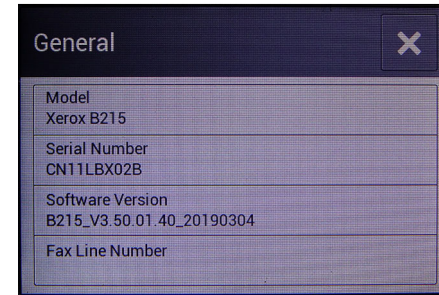

N-1-6086-A

Figure 1 General information screen entry

**NOTE:** The Firmware version is also printed in the Configuration Report under Device Setup labeled, System Software Version. Refer to GP 6, Machine Reports.

### Procedure (B205)

From the Control Panel:

1. Press the <Information> button.
  2. Use the up/down arrows to scroll to **Info Pages**, then press the <OK> button.
  3. Use the up/down arrows to scroll to **Configuration** then press the <OK> button to print a configuration report.
  4. See [**System Software Version**] under <Device Setup> heading.
- or:
1. Enter Diagnostics Mode, GP 1:
  2. Use the up/down arrows to select <Report> then press <OK>.
  3. Use the up/down arrows to select the desired report to print, press <OK>, then <OK> again to print the report.

The firmware version is listed under Device Setup > System.

## GP 4 Machine Settings

### Purpose

Use this procedure is used to provide information on how to select and change machine settings from the B215 UI, B205 Control Panel, CWIS, and the Easy Print Manager.

### Procedure (B215 UI)

1. At the Home screen touch **[Device > General]**, [Figure 1](#).

The following configuration settings are available:

- Date & Time
- Display Brightness
- Power Save Timer
- Timers
- Measurements
- Altitude Adjustment, refer to [GP 5](#).
- Humidity Adjustment

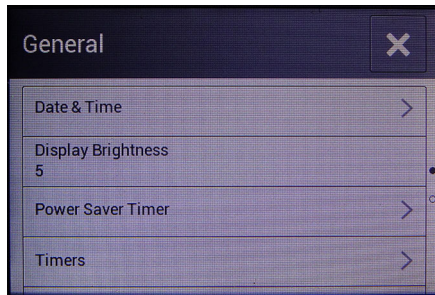

N-1-6099-A

Figure 1 General screen

2. At the Home screen touch **[Device > Paper Trays]**, [Figure 2](#).

The following configuration settings are available:

- Tray 1
- Manual Feed Slot

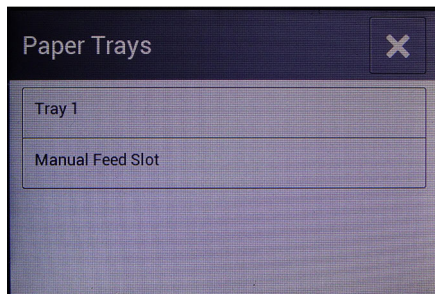

N-1-6091-A

Figure 2 Paper tray screen

3. At the Home screen touch **[Device > Network]**, [Figure 3](#).

The following configuration settings are available:

- Network Connectivity
- TCP IP Settings
- Advanced Settings
- Display Network Settings
- Clear Settings

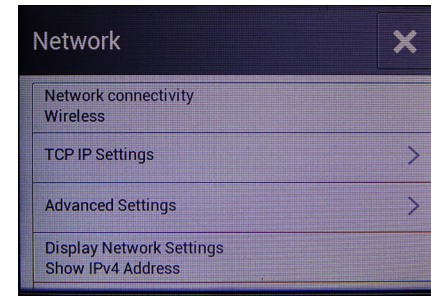

D-1-6108-A

Figure 3 Network settings screen

4. At the Home screen touch **[Device > App Defaults]**, [Figure 4](#).

The following configuration settings are available:

- Copy Default
- ID Card Copy Default
- Fax Default
- Fax Setup

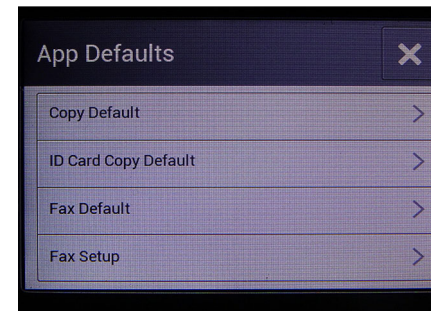

N-1-6106-A

Figure 4 App defaults screen

## Procedure (B205)

### From the Control Panel:

1. Press the <Information> button.
2. Use the up/down arrows to scroll to the following menu items:
  - Feature Default
  - Print Setup
  - System Setup
  - Network
3. Use the up/down arrows to scroll to the associated sub-menus to select machine settings.
  - For a detailed menu map, press the Information Button then select: <Info Pages>.

## CWIS and Easy Print Manager Settings

### From CWIS

1. Connect to the Xerox® B215/B205 Printer via Ethernet or WiFi.
2. Open Easy Print Manager and select [**Advanced Settings > Device Settings > Link to Program**].

### OR

Type the machine IP address in a browser address line to open CWIS.

3. Login in to CWIS. <default> Username: [admin] Password: [machine full serial number].

**NOTE:** The <default administrator password> is the [machine full serial number] by default. If the customer has changed the default password and a [Memory Clear] has been performed on the machine, the administrator password is reset to the default password. Change the administrator password back to the customer password as required.

4. Select the [**Properties**] tab, then select from the following menu items to change the machine settings.

### [General Setup]

- Configuration
- SMart eSolutions
- Alert Notification
- Date and Time
- Power Management
- Duplex Mode
- Tray Settings

### [Billing and Counters]

- Billing Information
- Usage Counters

### [Connectivity]

- [**Physical Connections**]
  - Ethernet
- [**Protocols**]
  - TCP/IP
  - SLP
  - SNMP

- SNMPv3
- WINS
- LPR/LPD
- Raw TCP/IP Printing
- IPP
- LDAP
- HTTP
- Google Cloud Print
- Proxy Server
- Wireless Setup
- Wi-Fi Direct™
- WSD
- AirPrint
- SNTIP
- Mopria

### [Login / Permissions]

- Login Methods
- Print Permissions
- Device User Database

### [Services]

- Display
- Printing
- Copy
- Email
- Fax (B215 only)
- USB
- ID Card Copy

### [Security]

- IP Filtering
- IP Sec
- Machine Digital Certificate
- Conceal Job Names
- 802.1x
- Trusted Certificate Authorities
- Display Network Settings
- System Timeout
- USB Port Security
- Security Settings
- Software Verification Test

### [Maintenance]

- Administrator Password
- Firmware Upgrade
- Upgrade Management

## GP 5 Altitude Adjustment

### Purpose

Print quality is affected by atmospheric pressure, which is determined by the height of the machine above sea level.

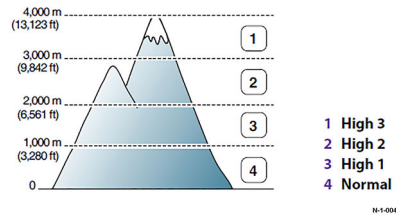

Figure 1 Altitude values

### Procedure (B215)

1. Touch [Device > General > Altitude Adjustment], Figure 2.

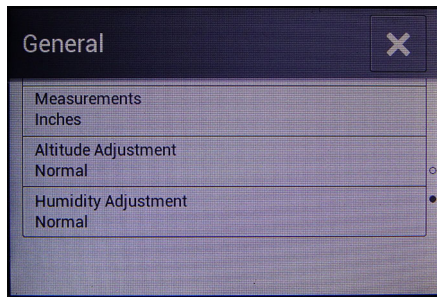

Figure 2 Altitude adjustment select screen

2. Touch the appropriate Altitude setting for the region, Figure 1 and Table 1.

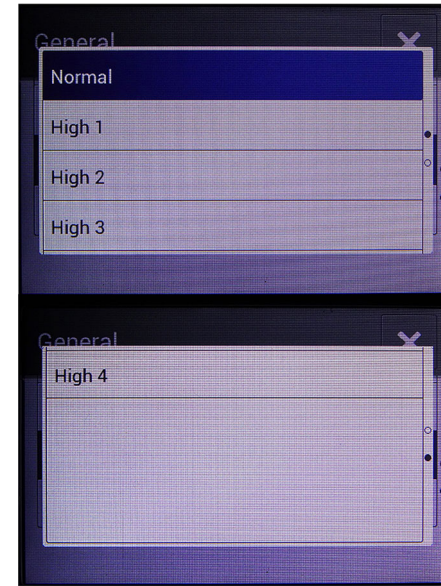

Figure 3 Altitude setting selection

Table 1 Altitude Values

Altitude	Value
0 - 1000 M 0 - 3,280 ft.	Normal
1000 - 2000 M 3,280 - 6,561 ft.	High 1
2000 - 3000M 6,561 - 9,842 ft.	High 2
3000 - 4000 M 9,842 - 13,123 ft.	High 3
4000 - 5000 M 13,123 - 16,404 ft.	High 4

## Procedure (B205)

1. Determine altitude of machine placement.
2. Press the **[Information]** button on the Control Panel, then use the Up/Down arrow to select **[Machine Status > System Setup > Machine Setup > Altitude Adjust.]**.
3. Using the up/down arrows to select the correct Altitude setting, [Table 2](#).

Table 2 Altitude Values

Altitude	Value
0 - 1000 M 0 - 3,280 ft.	Normal
1000 - 2000 M 3,280 - 6,561 ft.	High 1
2000 - 3000M 6,561 - 9,842 ft.	High 2
3000 - 4000 M 9,842 - 13,123 ft.	High 3
4000 - 5000 M 13,123 - 16,404 ft.	High 4

## GP 6 Machine Reports

### Purpose

Use this procedure to access and print machine reports. The information in the machine reports may be useful for troubleshooting problems.

### Diagnostics (B215)

1. Enter Diagnostics Mode, [GP 1](#).
2. Touch **[Report]** to access the Machine Reports, [Figure 1](#).

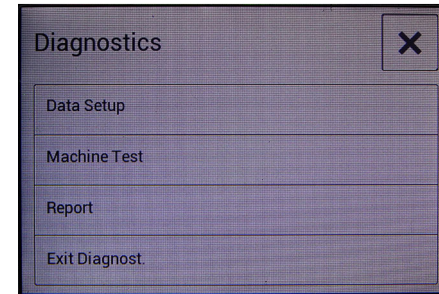

N-1-6054-A

Figure 1 Diagnostics Home screen

3. Scroll the UI screen for a full list of reports, touch the report to be printed, [Figure 2](#).
  - **Protocol Dump:** Prints Fax Protocol data.
  - **Supplies Information:** Prints general supplies and HFSI (under **<Other Consumables Life>** heading) information.
  - **Error Information:** Displays fault codes, error types, error counts and date/time.
  - **Usage Counter:** Total impressions, impression type and sheet counts.
  - **Fax Options:** Fax Setup.
  - **Service Support:** Prints as **<Customer Assistance>**, Lists machine support information to assist support calls including the Xerox support website and phone number.

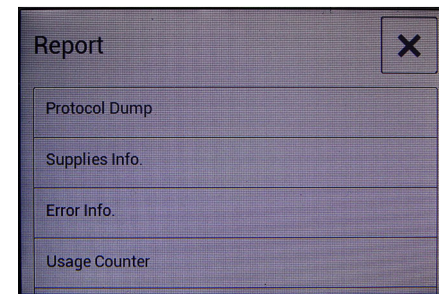

N-1-6080-A

Figure 2 Reports select screen



4. Touch **[Print]** to print the report or **[Close]** to return to the report list, [Figure 3](#).

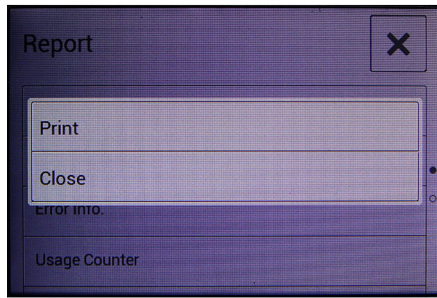

N-1-6081-A

Figure 3 Print select screen

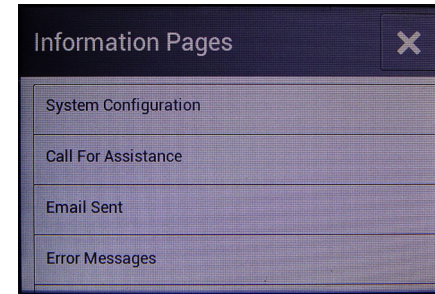

N-1-6088-A

Figure 4 Information pages select screen

## User Mode

1. From the **[Home]** screen, touch **[Device > Information Pages]** to access the Information Pages to print, [Figure 4](#).

Scroll the UI screen for the complete list of Information Pages for printing:

- **System Configuration**
- **Call for Assistance**
- **Email Sent**
- **Error Messages**
- **Fax Broadcast**
- **Fax Options**
- **Fax Phonebook**
- **Fax Protocol**
- **Fax Receive**
- **Fax Transmission**
- **Group Address Book Members**
- **Junk Fax List**
- **Last 40 Error Messages**
- **Local Address Book Members**
- **Pending Jobs**
- **User Authentication**
- **Supplies Usage**
- **All Information Pages**

## Diagnostics (B205)

Follow the steps below to access machine reports.

1. Enter Diagnostics Mode, [GP 1](#).
2. At the **<Tech Menu>** line, press **<OK>**.
3. Using the up/down arrows, scroll to **<Report>** then press **<OK>**.
4. Use the up/down arrows to choose from the following reports:
  - **Supplies Information:** Prints general supplies and consumables information
  - **Error Information:** Displays fault codes, error types, error counts and date/time.
  - **Usage Counter:** Total impressions, impression type and sheet counts.
  - **Customer Assistance:** Provides Xerox support services information.

## User Mode (B205)

1. From the Control Panel, press the **<Information>** button. Using the up/down arrows, navigate to **<Info Pages>** then select from the following reports:
  - **Configuration**
  - **Error Message**
  - **Adj info**
  - **Supplies Information**
  - **Usage Counters**
  - **PCL Font**
  - **Supplies Usage**
2. Select **<OK>** to confirm menu selections.

## Additional Resources

- For detailed information on Machine reports, refer to Section 1: Getting Started, Information Pages, in the Xerox® B215/B205 User Guide.
- For accessing and printing machine reports from a networked PC using CentreWare Internet Services (CWIS), refer to Section 12: Troubleshooting; Further Assistance, in the Xerox® B215/B205 User Guide.

## GP 7 Firmware Upgrade

### Purpose

To upgrade the firmware using one of two methods. Refer to the product technical overview, Software Upgrade Methods:

- via Xerox CentreWare Internet Services (CWIS) upgrade, remote upgrade.
- via USB upgrade.

### Xerox CentreWare Internet Services (CWIS) upgrade (B215 and B205)

Download the latest software update. From the Xerox Support website at [www.xerox.com/office/B215\\_B205support](http://www.xerox.com/office/B215_B205support), select the .hd file.

**NOTE:** The following procedure is created using the Chrome® Internet browser. The verbiage may vary depending on the Internet browser used.

1. Open an Internet web browser, then type the IP address of the machine to be upgraded in the web browser address line.
2. After the CentreWare Internet Services (CWIS) window opens, select the **[Properties]** tab, then select **[Maintenance]**.
3. Select **[Upgrade Management]**.
4. Login as Administrator <default>:
  - Username: **[admin]**
  - Password: **[machine full serial number]**

**NOTE:** If the machine full serial number is incorrect, check with the customer for a custom password set by the customer.

**NOTE:** The <default administrator password> is the **[machine full serial number]** by default. If the customer has changed the default password and a **[Memory Clear]** has been performed on the machine, the administrator password is reset to the default password. Change the administrator password back to the customer password as required.

5. Select **[OK]**, verify the **[Software Upgrade Enabled]** check box is selected.
6. Select **[Firmware Upgrade]**.
7. Click the **[Choose File]** button, browse to the location of the firmware .hd upgrade file, then select the file.
8. Click on the **[Install Software]** button: The printer automatically initializes after the upgrade is complete.
  - A dialog box opens with a progress bar showing the percentage of file transfer completion.
  - The machine will restart completing the Firmware Upgrade.
9. Check the firmware version to confirm the upgrade was successful (print a Configuration Report).

**NOTE:** Disable Firmware Upgrades to secure the printer following the upgrade procedure.

### USB upgrade

Download the latest software update. From the Xerox Support website at [www.xerox.com/office/B215\\_B205support](http://www.xerox.com/office/B215_B205support), select the .hd file.

### USB FW upgrade processes for B215

1. Download the FW file onto a USB Flash drive.
2. Insert the USB flash drive into the USB host port of the device (just below the UI control panel).
3. Select **[Print from USB]** on the control panel.
4. Select **[Add File]**.
5. Select the firmware file for the <B215> from the list displayed on the control panel, then touch the check mark.
6. Select **[Print]**.

**NOTE:** **[Print]** will be grayed out on the UI while the device reads the file. It may take 30-45 seconds for the device to read the file.

The UI screen will return to the Home screen before showing the **[SW Update in Progress]** gas gauge.

7. After the device restarts, remove the USB flash drive.
8. A Configuration page will print, check the Configuration page to make sure the firmware upgrade was successful.

**NOTE:** Look under the section **Device Setup>System Software Version** in the Configuration Report. The version listed should reflect that latest firmware update.

### USB FW upgrade processes for B205 (2-line LCD)

1. Download the FW file onto a USB Flash drive.
2. Install the USB Flash drive into the Flash drive port of the device (just below the control panel).
3. Select **[USB Print]**.
4. Use **[Up]** and **[Down]** arrows to scroll to find the correct file, hit **[OK]**.
5. Select **[Yes]** for Firmware Upgrade.

**NOTE:** It may take 30-45 seconds for the device to read the file.

6. If screen shows Copies 1 - 9999, Hit **[OK]**.  
The followed steps will occur:
  - Flash Upgrade
  - Rebooting
  - System Initialize
7. A Configuration page will print, check the Configuration page to make sure the FW upgrade was successful.

**NOTE:** Look under the **Device Setup** section, **System Software Version** should reflect that latest FW update.



## GP 8 Usage of the Electrostatic Discharge (ESD) Field Service Kit

### Purpose

The purpose of the Electrostatic Discharge (ESD) Field Service Kit is to preserve the inherent reliability and quality of sensitive electronic components handled by the service representative. The kit should be used whenever handling the circuit boards or any other ESD sensitive components.

### Procedure

1. Switch off the machine power and disconnect the machine power cords.
2. Assemble the kit:
  - a. Place the static dissipative work surface mat on a flat surface in close proximity to the machine or the component
  - b. Connect the snap end of the green grounding cord to the snap on the static dissipative work surface mat. Connect the male end (plug) to the frame.
  - c. Connect the small snap end of the blue cord to the top snap on the green grounding cord.
  - d. Connect the small snap end of the blue cord to the snap on the adjustable cloth wrist strap or the ESD wristwatch.
  - e. Install the adjustable wrist strap or ESD wristwatch securely on the wrist.
3. The circuit boards (PWBs) and ESD sensitive components can now be handled without causing any ESD related damage. Place all of the components removed from the machine onto the static dissipative work surface mat.
4. New replacement components, as well as defective components, should be handled during unpacking and repacking using the ESD Field Service Kit. During transfer from or to the packing material or container, the PWB should be placed on the static dissipative work surface mat.

## GP 9 DC 305 UI Button Test Sequence (B205)

### Purpose

Use this procedure to access and run the DC 305 UI Button Test.

### Procedure

1. Enter the Diagnostic Mode, **GP 1**, at the **[Tech Mode]** line, press **[OK]**.
2. Use the navigation buttons to scroll to the **[Machine Test]** sub-menu.
3. The screen should display **<DC305 UI test>**, press any button to start the LCD test.
4. Press the **[OK]** button 2 times. A series of black boxes will be shown on the Control Panel display.
5. Press the **[OK]** button until **<PRESS BELOW Copy Mode 00>** is displayed on the Control Panel. Press the **[Copy Mode]** button to continue. The screen will display **<DC 305 UI test>**.
6. Test the display buttons by pressing them sequentially, as indicated on the Control Panel display.

**NOTE:** The **[OK]** button does not have an indicator light. It is depicted by a series of black boxes displayed when the Menu button is pressed. Press the **[OK]** button to test the button and return to the test sequence.

7. Press the **[Stop]** button to end the test. All control panel lights are illuminated.
8. Continue pressing the **[Stop]** button until all control panel indicator lights are turned off and the machine is returned to Copy mode.

# GP 10 SA Password Reset

## Purpose

The SA Password Reset process steps through resetting the SA Password back to the default value (device serial number) via a Memory Clear. The Memory Clear function forces the value in a particular location on the Main PWB to become the SA Password. The value that resides in this location is the device serial number.

### CAUTION

*Performing a Memory Clear sets the SA Password back to the default value (device serial number). Inform the customer to reset the SA Password back to the customer created password.*

## Procedure

### B215 [Clear All Memory]

1. Switch on the machine.
2. Enter Diagnostics, **GP 1**, then perform the <Clear All Memory> operation: **[Data Setup > Machine Data > Clear All Memory]**.
3. Print a Configuration Report, refer to **GP 2**, Machine Reports, then verify the original machine serial number is displayed under the <Device Profile> heading.

### CAUTION

*Each time a Memory Clear operation is performed the NVM is cleared and must be initialized. Perform dC132 NVM INIT.*

**NOTE:** After performing a Memory Clear, inform the customer that they will need to re-establish their Wireless or Ethernet connection.

### B205 [Clear All Memory]

1. Switch on the machine.
2. Enter Diagnostics, **GP 1**, then perform the <Clear All Memory> operation: **[Data Setup > Machine Data > Clear All Memory]**.
3. Print a Configuration Report, refer to **GP 2**, Machine Reports, then verify the original machine serial number is displayed under the <Device Profile> heading

### CAUTION

*Each time a Memory Clear operation is performed the NVM is cleared and must be initialized. Perform dC132 NVM INIT.*

**NOTE:** After performing a Memory Clear, inform the customer that they will need to re-establish their Wireless or Ethernet connection.

## Diagnostic Information

### Diagnostic Mode Menu - Data Setup

#### Purpose

This section of the Service Documentation contains information about Diagnostic Procedures. This section also contains various other product-specific information that may be useful and/or needed for servicing the machine.

To enter Diagnostics Mode, refer to [GP 1](#), Entering and Exiting Diagnostics.

**Table 1 Diagnostic Mode Menu - Data Setup**

Level 1	Level 2	Level 3	Level 4	Level 5	Level 6	B205	B215	
Data Setup	Send Level	India, Nepal and China - [0-15], Other Countries - [9-15]	12			NA	YES	
	DTMF Level	(High) 0-15	(Low) 0-15			NA	YES	
	Pause Time	1-9				NA	YES	
	Dial Mode	Tone					NA	YES
		Pulse					NA	YES
	Modem Speed	33.6					NA	YES
		28.8					NA	YES
		14.4					NA	YES
		12.0					NA	YES
		9.6					NA	YES
		4.8					NA	YES
	Error Rate	10%					NA	YES
		5%					NA	YES
	*Clear All Memory					YES	YES	
	Toner Low Level	1-50%					YES	YES
	ImgU. Low Level	1-50%					YES	YES
	Clear Counts	Enter <1934>	Fuser				YES	YES
			Transfer Roller				YES	YES
			Pickup Roller				YES	YES
			Retard Roller				YES	YES
			Forward Roller				YES	YES
			ADF Roller				YES	YES
			ADF Rubber Pad				YES	YES
Engine Footer	Off					YES	YES	
	On					YES	YES	
Dial Tone	On					NA	YES	
	Off					NA	YES	

Table 1 Diagnostic Mode Menu - Data Setup

Level 1	Level 2	Level 3	Level 4	Level 5	Level 6	B205	B215
Data Setup	Caller ID	On Off				NA	YES
	Busy Tone	On Off				NA	YES
	Wrap Jam Clear	On/Off				YES	YES
	F/W Upgrade	On Off				YES	YES
	**Set Serial No.	XXX-xxxxxx				YES	YES
	CRU Reg. Reset	Yes No				NA	YES
	Format Flash	Yes No	Formatting...	Completed	Reboot Machine Please Wait...	YES	YES
	Capture Log					YES	YES
	Debug Log	Enable Disable				YES	YES
	UI Log Level	Normal Detail 1 Detail 2				NA NA NA	YES YES YES

**NOTE:** \*The <default administrator password> is the [machine full serial number] by default. If the customer has changed the default password and a [Memory Clear] has been performed on the machine, the administrator password is reset to the default password. Change the administrator password back to the customer password as required.

**NOTE:** \*\* Indicates there is a function in Diagnostics that allows for entry of the serial number using the UI in Diagnostic Mode, (Ref. GP 1). On the B205 select: [Data Set Up>Set Serial Number], then using the keypad, enter the serial number. Press the <OK> button to confirm selections. **This function allows numeric entries only.** For serial numbers containing alpha characters (letters) use the serial number writing tool; USB\_Serial.V1.02.exe.

## Diagnostic Mode Menu - Machine Test

Table 2 Diagnostic Mode Menu - Machine Test

Level 1	Level 2	Level 3	Level 4	Level 5	Level 6	B205	B215	
Machine Test	DC305 UI Test (Ref. GP 9)	Press any key to start				YES	NA	
	Modem Test	Single Tone 1100Hz Line 1					NA	YES
		Single Tone 1650Hz Line 1						
		Single Tone 1850Hz Line 1						
		Single Tone 2100Hz Line 1						
		V.21 300 bps Line 1						
		V.27ter 2400 bps Line 1						
		V.27ter 4800 bps Line 1						
		V.29 7200 bps Line 1						
		V.29 9600 bps Line 1						
		V.17 7200 bps Line 1						
		V.17 9600 bps Line 1						
		V.17 12000 bps Line 1						
		V.17 14400 bps Line 1						
		V.34 2400 bps Line 1						
		V.34 4800 bps Line 1						
		V.34 7200 bps Line 1						
		V.34 9600 bps Line 1						
		V.34 12000 bps Line 1						
		V.34 14400 bps Line 1						
		V.34 16800 bps Line 1						
	V.34 19200 bps Line 1							
	V.34 21600 bps Line 1							
	V.34 24000 bps Line 1							
	V.34 26400 bps Line 1							
	V.34 28800 bps Line 1							
	V.34 31200 bps Line 1							
V.34 33600 bps Line 1								
On Line Quiet State								
DRAM Test						YES	YES	
ROM Test						YES	YES	
Continuous DTMF	DTMF # Line 1					NA	YES	
	DTMF *Line 1					NA	YES	
	DTMF 0 Line1					NA	YES	

Table 2 Diagnostic Mode Menu - Machine Test

Level 1	Level 2	Level 3	Level 4	Level 5	Level 6	B205	B215
		DTMF 1 Line1				NA	YES
		DTMF 2 Line1				NA	YES
		DTMF 3 Line1				NA	YES
		DTMF 4 Line1				NA	YES
		DTMF 5 Line1				NA	YES
		DTMF 6 Line1				NA	YES
		DTMF 7 Line1				NA	YES
		DTMF 8 Line1				NA	YES
		DTMF 9 Line1				NA	YES
	Test Pattern	Test Pattern 1				YES	YES
		Test Pattern 2				YES	YES
	Shading Test	Shading & Print				YES	YES
		Print				YES	YES
	Scan Aging	Status Display(ON/OFF)				YES	YES
	<b>Diagnostics Mode</b>	<b>DC131 NVM Read/ Write</b>	09-110 MHVBias	MHV DC K	Range: 0-20, Default: 10 Offset -30 ~ +30 (21 Steps / 3 interval)	YES	YES
			09-130 DevBias	Deve DC K	Range: 0-20, Default: 10 Offset -30 ~ +30 (21 Steps / 3 interval)	YES	YES
			09-120ATTRBias	THV K	Range: 0-20, Default: 10 Offset -30 ~ +30 (21 Steps / 3 interval)	YES	YES
			09-121 ATTRDup	THV K_Dup	Range: 0-20, Default: 10 Offset -30 ~ +30 (21 Steps / 3 interval)	YES	YES
			10-100 RdyTemp	Ready Temp K	Range: 0-20, Default: 10 Offset -20 ~ +20 (21 Steps / 2 interval)	YES	YES
			10-105 PrtTemp	Print Temp K	Range: 0-20, Default: 10 Offset -20 ~ +20 (21 Steps / 2 interval)	YES	YES
			09-100 LSU	LD Power K	Range: 0-20, Default: 10 Offset -20 ~ +20 (21 Steps / 2 interval)	YES	YES
		<b>DC132 NVM Initialize</b>	Print NVM Initialization	MHV DC K Deve DC K THV K THV K_Dup Ready Temp Print Temp LD Power K		YES	YES
			Fax NVM Initialization	All Fax settings initialized		NA	YES

Table 2 Diagnostic Mode Menu - Machine Test

Level 1	Level 2	Level 3	Level 4	Level 5	Level 6	B205	B215
		<b>DC330 Component Control</b>	(2L)04-100 Motor, (GUI)04-100 Main BLDC Motor	MainBLDCMotor	ON/OFF	YES	YES
			(2L)04-100 Motor, (GUI)04-100 Main BLDC Motor	Main BLDC Rdy	High/Low	YES	YES
			(2L)08-810-Clutch, (GUI)08-810 Tray1 Pickup Clutch	Tray 1 Pickup	ON/OFF	YES	YES
			(2L)08-850-Clutch, (GUI)08-850 Registration Clutch	Registration	ON/OFF	YES	YES
			(2L)08-720-Clutch, (GUI)08-720 OutBin Full Clutch	Out Bin Full	High/Low	YES	YES
			(2L)07-110 Sensor, (GUI)07-110 Tray1 Empty Sensor	Tray1 Empty	LOW/OFF	YES	YES
			(2L)08-100 Sensor, (GUI)08-100 Feed Sensor	Feed Sens	LOW/OFF	YES	YES
			(2L)08-500 Sensor, (GUI)08-500 Regi. Sensor	Regi Sens	LOW/OFF	YES	YES
			(2L)08-600 Sensor, (GUI)08-600 Exit Sensor	Exit Sens	LOW/OFF	YES	YES
			(2L)09-100 Charger, (GUI)09-100 Black MVH Bias	K MHV Bias	ON/OFF	YES	YES
			(2L)09-200 Dev, (GUI)09-200 Black Dev Bias	K Dev Bias	ON/OFF	YES	YES
			(2L)09-300Transfer, (GUI)09-300 Black THV Bias	K THV Bias	ON/OFF	YES	YES
			(2L)09-400Transfer, (GUI)09-400 Black THV(-) Bias	K THV(-) Bias	ON/OFF	YES	YES
			(2L)09-310Transfer, (GUI)09-310 Black THV Bias Read	K THV Bias R	OFF/Value	YES	YES
			(2L)10-200 Fuser, (GUI)10-200 Fuser Temperature A	Temp A	OFF/Value	YES	YES
			(2L)06-110 LSU, (GUI)06-110 LSU Motor1 Ready	LSU Mot1 Rdy	High/Low	YES	YES
			(2L)06-100 LSU, (GUI)06-100 LSU Motor1 Run	LSU Mot1 Run	ON/OFF	YES	YES
			(2L)06-200 LSU, (GUI)06-200 LSU LD Power4	LD Power4	ON/OFF	YES	YES
		(2L)06-400 LSU, (GUI)06-400 LSU HSync4	LSU HSync4	High/Low	YES	YES	



## Diagnostic Mode Menu - Report

Table 3 Diagnostic Mode Menu - Report

Level 1	Level 2	B205	B215
Report	Protocol Dump	NA	YES
	Supplies Info	YES	YES
	Error Info	YES	YES
	Usage Counter	YES	YES
	Fax Options	NA	YES
	Service Support	YES	YES

Table 4 Diagnostic Mode Menu - Exit Diagnostics.

Level 1	Level 2	B205	B215
Exit Diagnostics.	Yes	YES	YES
	No	YES	YES

## EDC MODE - (Diagnostics Mode)

### DC131 NVM Read/Write

#### Purpose

Table 1, provides NVM Read/Write values to review and modify machine control parameters stored in Non-Volatile Memory (NVM).

Table 1 NVM Codes and values

NVM Code	B215 UI	B205 LCD	Definition	Default	Max/Min	Description	B205	B215
09-110	MHV DC Black (MHV Bias Control)	MHV DC K	Charger HV Black DC Duty	10	20 / 0 (21Steps)	Offset -30 ~ +30 (21 Steps / 3 interval)	YES	YES
09-130	Deve DC Black (Deve Bias Control)	Deve DC K	Deve DC Black	10	20 / 0 (21Steps)	Offset -30 ~ +30 (21 Steps / 3 interval)	YES	YES
09-120	Transfer1 High Voltage(THV) Black (THV Bias Control)	THV K	Transfer1 HV Black Duty	10	20 / 0 (21Steps)	Offset -30 ~ +30 (21 Steps / 3 interval)	YES	YES
09-121	Transfer1 High Voltage(THV) Duplex Black (THV Bias Control)	THV K_Dup	Transfer1 HV Black Duplex Duty	10	20 / 0 (21Steps)	Offset -30 ~ +30 (21 Steps / 3 interval)	YES	YES
10-100	StandBy Temperature offset	Ready Temp	Target Temperature during standby mode.	10	20 / 0 (21Steps)	Offset -20 ~ +20 (21 Steps / 2 interval)	YES	YES
10-105	Run Temperature offset	Print Temp	Target Temperature during run mode.	10	20 / 0 (21Steps)	Offset -20 ~ +20 (21 Steps / 2 interval)	YES	YES
09-100	LD Power Black (LD Light Level Black)	LD Power K	Black LD Power at Normal Speed	10	20 / 0 (21Steps)	Offset -20 ~ +20 (21 Steps / 2 interval)	YES	YES

### DC132 NVM Initialization

#### Purpose

Table 2, provides NVM Initialization operations and parameters.

#### CAUTION

*Each time a Memory Clear, GP 10, is performed the NVM must be initialized.*

Table 2 NVM Initialization

NVM INIT Operation	Parameters Initialized	B215	B205
Print NVM Initialization	MHV DC K Deve DC K THV K THV K_Dup Ready Temp Print Temp LD Power K	YES	YES
Fax NVM Initialization	All Fax settings initialized	YES	NA

## DC330 Component Control Codes

### Purpose

Table 3, provides component control codes for the purpose of troubleshooting components within the machine.

**Table 3 Component Control**

Diagnostic Code	Chain Code	Displayed on B215 UI	Display on B205 LCD	Definition	BIT	Input/ Output	State Displayed	Related Component
04-100	100	Main BLDC Motor	Main BLDC	Main Feed (BLDC) Motor is On/Off	BIT_0	Output	On[Off]	Engine
04-110	100	Main BLDC Motor Ready	Main BLDC Rdy	Detect if Main Feed (BLDC) Motor runs at normal speed	BIT_0	Input	High[Low]	Engine
06-100	110	LSU Motor1 Run	LSU Motor1 Run	LSU Motor1 On/Off	BIT_10	Output	On[Off]	Engine
06-110	110	LSU Motor1 Rdy	LSU Motor1 Rdy	Detects if LSU motor1 runs at normal speed	BIT_12	Input	High[Low]	Engine
06-200	110	LSU LD Power4	LSU LD Power4	LSU LD4 Power On/Off (black)	BIT_11	Output	On[Off]	Engine
06-400	110	LSU HSync4	LSU HSync4	Horizontal Sync		Input	High[Low]	Engine
07-110	102	T1 Paper Empty Sensor	Tray 1 Empty	Detects when a sheet is in Tray1	BIT_16	Input	High[Low]	Engine
08-100	102	Feed Sens	Feed Sens	Detects when a sheet is at Feed sensor	BIT_7	Input	High[Low]	Engine
08-500	102	Regi Sens	Regi Sens	Detects when a sheet is at registration sensor	BIT_6	Input	High[Low]	Engine
08-600	102	Exit Sens	Exit Sens	Detects when a sheet is at Exit sensor	BIT_11	Input	High[Low]	Engine
08-720	101	Out-Bin Full Sensor	Out Bin Full	Detects when the output tray is full	BIT_14	Output	High[Low]	Engine
08-810	101	T1 Pick up Clutch	Tray1 Pickup	Engages drive to pick up a paper from tray1.	BIT_13	Output	On[Off]	Engine
08-850	101	Registration Clutch	Registration	Engages drive to registration rolls	BIT_15	Output	On[Off]	Engine
09-100	105	Black MHV Bias	K MHV Bias	Black MHV bias voltage on at normal drive level	BIT_24	Output	On[Off]	Engine
09-200	106	Black Dev Bias	K Dev Bias	Black Dev bias voltage on at normal drive level	BIT_25	Output	On[Off]	Engine
09-300	107	Black THV Bias	K THV Bias	Black THV bias voltage on at normal drive level		Input	On[Off]	Engine
09-310	107	Black THV Bias Read	K THV(-) BiasR	Black THV bias voltage			Numeric 3 digits	Engine
09-400	107	Black THV(-) Bias	K THV(-) Bias	Black THV bias voltage on at normal drive level		Input	On[Off]	Engine
10-200	109	Fuser Temperature A	Temp A	Detects what the temperature A is on fuser.		Input	Numeric 3 digits	Engine

## Data Setup (Fax Data)

### Purpose

Fax data is provided below for setting up and troubleshooting Fax performance in the **B215 only**.

- **Send Level**  
The level of the transmission signal (Tx). The Tx signal can be set to a value between 9dBm and 15 dBm. Normally, the Tx level should be less than 12 dBm.
- **DTMF Level High**  
The value of the High level tone in DTMF mode. (Not dial mode). High can be set to a value between 0 and 15.
- **DTMF Level Low**  
The value of the Low level tone in DTMF mode. (Not dial mode). Low can be set to a value between 0 and 15.
- **Pause Time**  
The delay time when receiving the pause input at auto dial. The pause time can be set to a value between 1 and 9 seconds.
- **Dial Mode**  
The type of dial method, either Dial or Pulse. The default setting is Dial.
- **Modem Speed**  
The modem speed is automatically set to a slower speed when communicating with a slower speed modem, as communication is done on the standard of the side where modem speed is low for transmission/reception. Available settings are 33.6 Kbps, 28.8 Kbps, 14.4 Kbps, 12.0 Kbps, 9.6 Kbps, and 4.8 Kbps. It is recommended to maintain the default setting of 33.6 Kbps.
- **Error Rate**  
When the error rate is about exceed the set value, the Baud rate automatically adjusts to 2400 bps. This ensures that the error rate remains below the set value. The error rate can be set to 5% or 10%.
- **Dial Tone**  
The dial tone feature can be set to on or off.
- **Caller ID**  
The caller ID feature can be set to on or off.
- **Busy Tone**  
The busy tone feature can be set to on or off

## Machine Data

### Purpose

Machine data is provided to assist device setup and troubleshooting machine failure.

- **Toner Low Level**  
This is used to set up when the customer is notified to replace the Toner Cartridge. The time can be set to 1-30%.
- **ImgU Low Level**  
This is used to set up when the customer is notified to replace the Imaging Unit. The time can be set to 1-50%.
- **Clear Counts**  
Use this to reset the copy counters for the following operations or components:
  - Fuser
  - Transfer Roller
  - Pickup Roller
  - Retard Roller
  - Forward Roller
  - ADF Roller
  - ADF Rubber Pad

**NOTE:** A password is required to reset these counters.
- **Engine Footer**  
This function is used to display the print engine status on the bottom of a printed page. It is set to either On or Off. The default setting is Engine footer Off.
- **Clear All Memory**  
To reset the system to factory default settings when the product is functioning abnormally. All system settings are returned to the default values, including all customer settings.

**NOTE:** **Clear All Memory** must be performed after replacing the Main PWB. Failure to do so could negatively effect machine performance.

**NOTE:** The **<default administrator password>** is the **[machine full serial number]** by default. If the customer has changed the default password and **[Clear All Memory]** has been performed on the machine, the administrator password is reset to the default password. Change the administrator password back to the customer password as required.
- **Firmware Upgrade**  
The F/W Upgrade feature can be set to on or off.
- **Set Serial Number**  
The Set Serial Number feature is used to manually input the machine serial number after replacing the Main PWB.
- **Format Flash**  
The Format Flash feature clears the flash memory which is allocated to store fonts.
- **Capture Log**
- **Debug Log**
- **UI Log Level**

## Machine Test

### Purpose

Machine tests are provided for troubleshooting assistance of machine related issues.

- **DC305 UI Test**  
The DC 305 UI Test is used to test the Control Panel buttons.
- **DC330 Component Control**  
Test routines available to verify component functionality by monitoring input signals and controlling output states.
- **DC131 NVM Read/Write**  
This routine provide the capability to view and modify machine control parameters stored in non-volatile memory.
- **DC132 NVM Initialize**  
This routine provides the ability to set the machine control parameters stored in non-volatile memory to default.
- **DRAM Test**  
Use this feature to test the system DRAM.
- **ROM Test**  
Use this feature to test the system ROM.
- **Test Pattern**  
Use this feature to generate a test pattern for troubleshooting image quality defects.
- **Shading Test**  
The Shading Test is performed to asses and optimize image quality by checking the Contact Image Sensor.
- **Scan Aging**  
An internal Engineering tool that tests the reliability of the Scanner Motor. (Not a field diagnostic function.)
- **Modem Test (B215 only)**  
The Modem Test transmits signals from the MODEM to a telephone. If no transmission sound is heard, the modem segment of the Main PWB has malfunctioned.
- **Continuous DTMF Test (B215 only)**  
Dual Tone Multi-Frequency Signal (DTMF) tests the line for the volume of the dialing and dial tone for machines equipped with a fax option.
- **EDC Mode**  
Execution of DC131 NVM INIT, DC132 NVM R/W, and DC330 CompControl.

## Printing Reports

### Purpose

The following reports are available from the B215 UI and B205 LCD panel.

- **Protocol Dump**  
Protocol report shows the sequence of the CCITT group 3 T.30 protocol during the most recent sending or receiving operation. Use this report to check for send and receive errors.
- **Supplies Info.**  
The Supplies Information report shows Toner Cartridge information such as toner remaining, toner capacity, and toner product date.
- **Error Info.**  
The Error Info report shows a list of all machine errors since the last service call.
- **Usage Counter**  
The Usage Page report shows the number of Duplex Print and Simplex prints since the last service call.
- **Fax Options**  
Show the current Fax settings, (i.e., Resolution, send confirmation, etc.)
- **Service Support / Cust. Assist**  
Lists machine support information required: machine serial number, model, software level, HFSI status, and additional machine configuration and status. The Xerox support website and phone number for machine support are provided also.

## Glossary of Terms

**NOTE:** For a comprehensive list of Xerox acronyms, refer to the Xerox Acronym database at: <https://open.xerox.com/Services/acronym>

**Table 1 Glossary**

Term/Acronym	Definition
802.11	802.11 is a set of standards for wireless local area network (WLAN) communications, developed by the IEEE LAN/MAN Standards Committee (IEEE 802).
802.11b/g/n	802.11b/g/n refers to specifications within the 802.11 family. 802.11b is also referred to as High-Rate or Wi-Fi, 802.11g is used for transmission over short distances and 802.11n adds multiple-input multiple-output.
ADF	Automatic Document Feeder. Scanning device that automatically feeds a document or stack of documents.
Bit Depth	A computer graphics term describing the number of bits used to represent the color of a single pixel in a bit mapped image. Bit depth determines the maximum number of colors that can be used at one time. 1-bit color is commonly called monochrome or black and white.
BOOTP	Bootstrap Protocol. Used by a network client to obtain an IP address from a configuration server. During computer startup, a BOOTP configuration server assigns an IP address to each client from a pool of addresses.
Control Panel	Area where control or monitoring instruments are displayed, typically located in the front area of the machine.
Default	The value or setting that is in effect when the printer/copier is first installed, reset, or initialized.
DHCP	The Dynamic Host Configuration Protocol. A standardized networking protocol used by servers on an IP computer network to allocate assigned IP addresses to a computer requesting an IP address.
DNS	Domain Name Server. The Domain Name Server translates alphabetic domain names into a corresponding IP address.
DPI	Dots Per Inch. The measure of the resolution of an image displayed on a screen or on a printed page, in dots or pixels.
Duplex	In printing, the capability to automatically turn over a sheet of paper so that the machine can print both sides of the sheet during one print cycle.
Duty Cycle	The proportion of time during which a device is active. (E.g., if the duty cycle for a printing device is 48,000 pages per month for 20 working days, the output that device can reliably produce is 2,400 pages a day.)
ECM	Error Correction Mode. A transmission mode built into fax machines or fax modems to automatically detect and correct errors in the transmission process.
Emulation	Hardware and/or software that emulates the functions of one computer system (the guest) in another computer system (the host).

**Table 1 Glossary**

Term/Acronym	Definition
Fuser	The Fuser subsystem permanently affixes toner onto print media by applying heat and pressure.
Gateway	A node (a router) on a TCP/IP network that serves as an access point to another network.
Grayscale	Varying shades of gray pixels ranging from black to white that represent different tones of an image.
Halftone	The reprographic technique that simulates continuous tone imagery through the use of dots, varying in either size, shape or spacing.
IP address	Internet Protocol Address. A unique number that devices use to identify and communicate with each other over a network utilizing the IP standard.
IPM	Images Per Minute. A measurement of printer speed that indicates the number of single-sided sheets a printer can complete within one minute.
IPP	The Internet Printing Protocol. A standard protocol that can be used locally or over the internet to create and manage print jobs, and to support access control, authentication, and encryption.
IPX/SPX	Internet Packet Exchange/Sequenced Packet Exchange. A networking protocol to provide connection services similar to TCP/IP, with the IPX protocol having similarities to IP, and SPX having similarities to TCP.
ISO	International Standardization Organization. An international standard-setting body that develops and promotes world-wide industrial and commercial standards.
ITU-T	International Telecommunication Union (Telecommunications sector). Established to standardize and regulate international radio and telecommunications.
ITU-T standard Chart number 1	Standardized test chart published by ITU-T for document facsimile transmissions.
JBIG	Joint Bi-level Image Experts Group (JBIG), is lossless (no loss of accuracy or quality) bi-level image compression standard. It's widely implemented in fax machines, but can also be used for other images.
JPEG	Joint Photographic Experts Group. A commonly used standard method of lossy (compressing data by losing some of it) compression for photographic images.
LED	A Light-Emitting Diode. A semiconductor device used to display machine status.
MFP	Multi Function Printer. A machine that includes multiple functions in one device such as; printing, copying, faxing, and scanning functions.
MH	Modified Huffman. A compression method for decreasing the amount of data that needs to be transmitted between fax machines to transfer the image.
MMR	Modified Modified READ. A compression method recommended by ITU-T T.6.

**Table 1 Glossary**

Term/Acronym	Definition
Modem	Modulator-Demodulator. A device that modulates an analog carrier signal to encode digital information, and demodulates a carrier signal to decode the transmitted information.
MR	Modified Read. A compression method that encodes the first scanned line (using MH), then compares the next line to the first, determines the differences, then encodes and transmits those differences.
OPC	Organic Photo Conductor. A mechanism that creates a virtual image for print using a laser beam emitted from a laser printer. Also referred to as Photoreceptor Drum.
Originals	The original is the first example of a document, photograph, chart, or any combination of these, used to produce others.
PABX	Private Automatic Branch Exchange. An automatic telephone switching system within a private enterprise.
PCL	Printer Command Language. A page description language developed to provide an efficient way to control printer features across various printing devices.
Printer Driver	A program used to send commands and transfer data from the computer to the printer.
Print Media	Material such as paper, envelopes, labels, and transparencies which can be used in printers, scanners, fax machines, or copiers.
PPM	Prints Per Minute. Used to measure printer speed. The number of copies or prints produced in one minute.
PRN file	An interface for a device driver that allows software to interact with the device driver by using standard input/output system calls.
Protocol	A convention or standard that controls or enables the connection, communication, and data transfer between two computing endpoints.
PSTN	Public Switched Telephone Network. The aggregate of the world's circuit-switched telephone networks providing infrastructure and services for public telecommunication.
Resolution	The sharpness of an image, measured in Dots Per Inch (DPI).
SMTP	Simple Mail Transfer Protocol. A text-based protocol generally used for sending messages from a mail client to a mail server.
TCP/IP	Transmission Control Protocol (TCP) / Internet Protocol (IP). The suite of protocols for communication between computers, used as a standard for transmitting data over networks.
Toner Cartridge	A bottle or container used in a xerographic copier/printer that contains the powder used to form the text and images on the printed paper.
TWAIN	An applications programming interface and communications protocol that regulates communications between software and digital imaging devices.
USB	Universal Serial Bus. A hardware interface that connects computers and peripherals. The USB is designed to concurrently connect a single computer USB port to multiple peripherals.

**Table 1 Glossary**

Term/Acronym	Definition
WEP	Wired Equivalent Privacy. A protocol for wireless local area networks that provides security by encrypting data over radio waves so that it is protected as it is transmitted from one end point to another.
WPS	The Wi-Fi Protected Setup. A standard for establishing a wireless home network, allowing easy wireless network connection without a computer.



## Tags/MODs

### Purpose

To provide a list of all the tag numbers used, together with a description of each of the machine modifications.

### Description

Each modification to the system is assigned a unique tag number. This section of the service documentation contains a listing and brief description of all change tags.

Change tags listed in this section are listed by machine module. The module to which the tag relates is identified by the tag prefix letter.

### Tag/MOD Information

Information that may be included with each tag item is as follows:

- Tag - identifies the control number for the tag.
- Class - identifies the classification code as listed in [Classification Codes](#).
- Use - indicates the block build or model designation of the machine.
- Manufacturing Serial Number - indicates the serial number of the factory-built machines with the modification installed.
- Name - indicates the name of the retrofit.
- Purpose - provides a brief description of the modification.
- Kit Number - identifies the part number of the kit or part required to install the modification.
- Parts List On - identifies the Part List location of the modification part.
- Reference - Indicates all other Tag/MOD numbers that are related to this product configuration. These may supercede or be superceded by another Tag/MOD.

### Mod/Tag Plate Location

Tags are identified by a tag number which is recorded on a tag matrix inside the front door.

### Classification Codes

The class or classification codes are described in [Table 1](#).

**Table 1 Classification codes**

NASG Code	XE Code	Description
-	1	Safety: install this tag immediately.
M	2	Mandatory: install this tag at the next opportunity.
R	3	Repair: install this tag as a repair, at the failure of a component.
O	4	Optional: install as a customer option or a field engineering decision.
S	4	Situational: install as the situation demands.
N	5	Manufacturing: cannot be installed in the field.
-	6	Refurbishing only.



BSD Block Schematic Diagrams..... 7-3  
BSD 1..... 7-4  
BSD 2..... 7-5



## **BSD Block Schematic Diagrams**

# **Xerox® B205/B215 Multifunction Printer**

This document contains wiring and mechanical power data for the Xerox® B205/B215 Printers.

These block schematic diagrams are supplemental to the diagnostic and troubleshooting information found in the Xerox® B205/B215 Service Manual.

Every effort has been made to achieve accuracy on these schematics. However, if a difference is noted between these schematics and the Xerox service documentation, the service documentation takes precedence.

EMILIA Series  
A1500S CONNECTION Diagram (Rev 0.0)

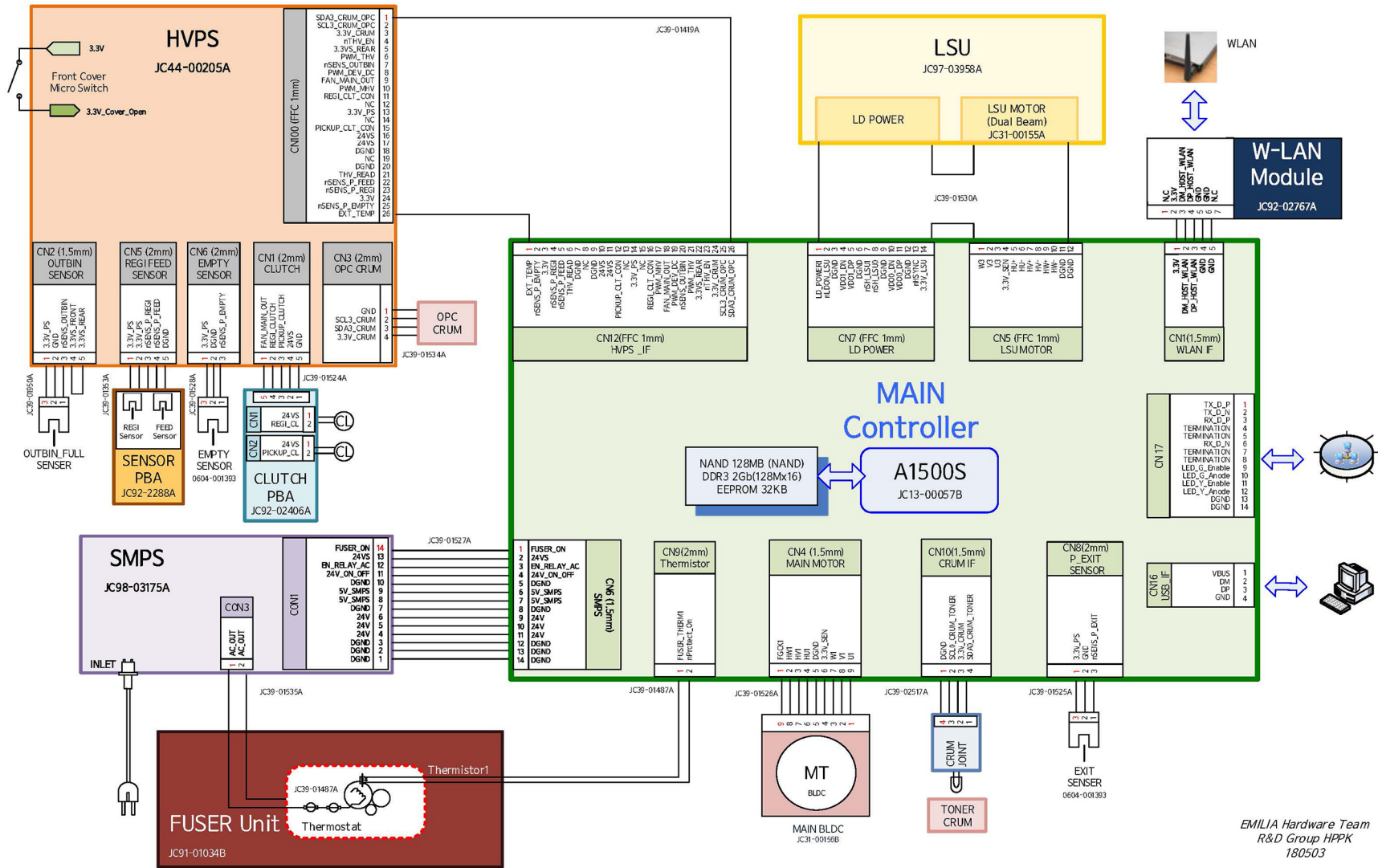

EMILIA Hardware Team  
R&D Group HPPK  
180503

Figure 1 1.1 - Main/Electrical/Power/Drive/LSU/Fuser/Network

# BSD 2

## 2. Scanner/ADF/UI/USB/Fax

### EMILIA Series A1500S CONNECTION Diagram (Rev 0.0)

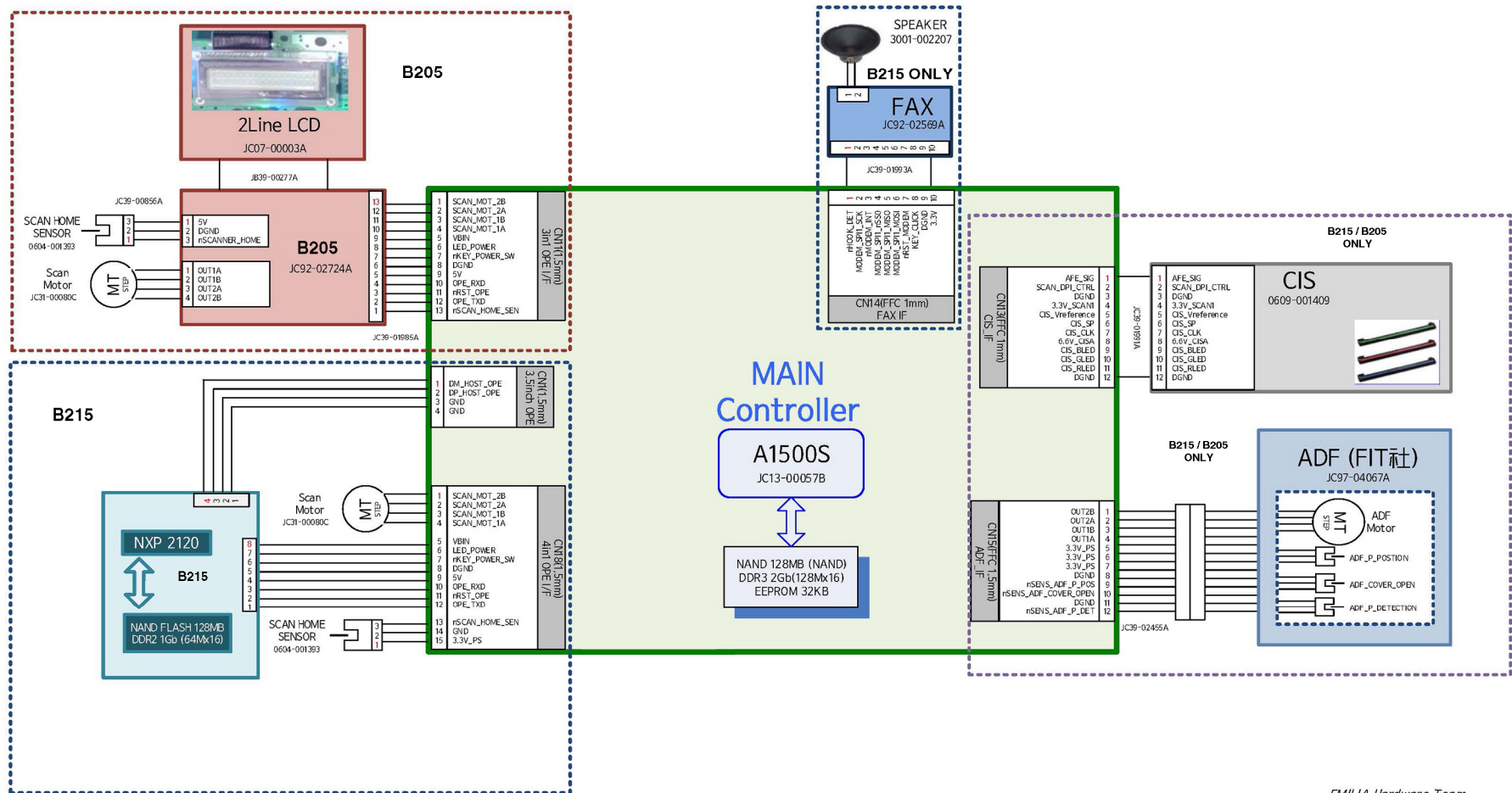

EMILIA Hardware Team  
R&D Group HPPK  
180503

Figure 1 2.1 Scanner/ADF/UI/USB/Fax





