

# Xerox® Phaser® 3052/3260 Service Manual

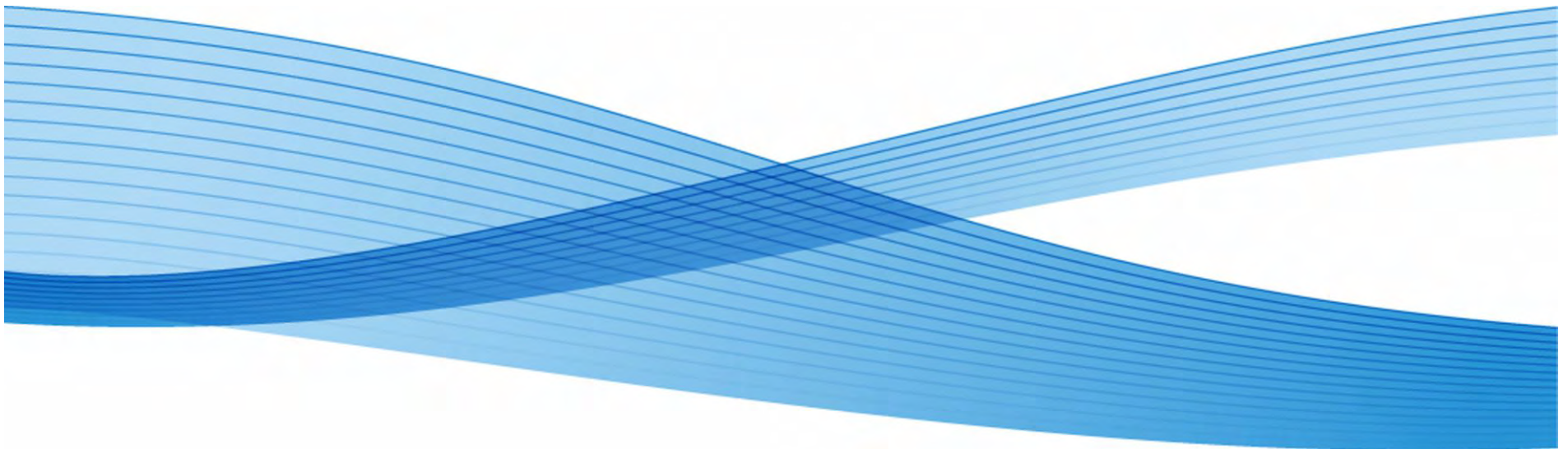

702P02830  
June 2014  
Initial Issue



Xerox® Phaser® 3052/3260 Service Manual

Service Documentation

Xerox® Phaser® 3052/3260 Service Manual

702P02830

June 2014

Prepared by:

Content Development and Language Services - North America

800 Phillips Road - Building 218-01A

Webster, New York 14580-9791

**ISO9001 and ISO27001 Certified**

©2014 Xerox Corporation. All rights reserved. Xerox®, Xerox and Design®, and Xerox® are trademarks of Xerox Corporation in the US and/or other countries.

Printed in the United States of America.

**\*\*\*Xerox Private Data\*\*\***

All service documentation is supplied to Xerox external customers for informational purposes only. Xerox service documentation is intended for use by certified, product-trained service personnel only. Xerox does not warrant or represent that it will notify or provide to such customer any future change to this documentation. Customer performed service of equipment, or modules, components, or parts of such equipment may affect whether Xerox is responsible to fix machine defects under the warranty offered by Xerox with respect to such equipment. You should consult the applicable warranty for its terms regarding customer or third-party provided service.

While Xerox has tried to make the documentation accurate, Xerox will have no liability arising out of any inaccuracies or omissions.

## WARNING

This equipment generates, uses and can radiate radio frequency energy, and if not installed and used in accordance with the instructions documentation, may cause interference to radio communications. It has been tested and found to comply with the limits for a Class A computing device pursuant to subpart J of part 15 of FCC rules, which are designed to provide reasonable protection against such interference when operated in a commercial environment. Operation of this equipment in a residential area is likely to cause interference in which case the user, at his own expense, will be required to correct the interference.

**DANGER:** Cet équipement génère, utilise et peut émettre des fréquences radio, et, s'il n'est pas installé et utilisé selon les recommandations du manuel d'instructions, peut causer des interférences aux communications radio. Il a été testé et jugé conforme aux limites des systèmes de catégorie A, conformément à la partie 15 de l'alinéa J des règlements FCC, établis pour protéger contre de telles interférences pendant le fonctionnement en milieu commercial. Dans une zone résidentielle, il peut causer des interférences; dans ce cas, l'utilisateur devra corriger le problème à ses propres frais.



About This Documentation.....	iii
How to Use this Manual .....	iv
Service Safety Summary.....	v
Reference Symbolology.....	vi
Voltage Specifications.....	vii
Health and Safety Incident Reporting .....	viii
Regulatory Specifications.....	ix
Translation of Warnings .....	x
Tag Usage.....	xi
Phaser® 3052/3260 Overview .....	xii



# About This Documentation

## Introduction

The Xerox® Phaser® 3052/3260 Service Manual is part of the multinational documentation for the Xerox® Phaser® 3052/3260 Printer. It is structured in standard Xerox service documentation format. This manual is the primary document used for diagnosing, repairing, maintaining, and troubleshooting these systems. The Service Manual is the controlling publication for a service call. Information about using this document is found in the Introduction section. To ensure understanding of this product, complete the Xerox Service Training Program for this particular printer.

## Organization

The Xerox® Phaser® 3052/3260 Printer Service Manual is organized and defined within the following sections:

### Section 1 Service Call Procedures

This section contains procedures that determine what actions are to be taken during a service call on the machine and in what sequence they are to be completed. This is the entry level for all service calls.

### Section 2 Status Indicator RAPs

This section contains the diagnostic aids for troubleshooting the Fault Code and non-Fault Code related faults (with the exception of image quality problems).

### Section 3 Image Quality Repair Analysis Procedures

This section contains the diagnostic aids for troubleshooting any image quality problems, as well as image quality specifications and image defect samples.

### Section 4 Repairs and Adjustments

This section contains the Adjustment and Repair procedures.

Repairs include procedures for removal and replacement of parts which have the following special conditions:

- When there is a personnel or machine safety issue.
- When removal or replacement cannot be determined from the exploded view of the Parts List.
- When there is a cleaning or a lubricating activity associated with the procedure.
- When the part requires an adjustment after replacement.
- When a special tool is required for removal or replacement.

Use the repair procedures for the correct order of removal and replacement, for warnings, cautions, and notes.

Adjustments include procedures for adjusting the parts that must be within specification for the correct operation of the system.

Use the adjustment procedures for the correct sequence of operation for specifications, warnings, cautions and notes.

### Section 5 Parts List

This section consists of a series of illustrations and an associated parts listing. Any part that is spared or any part that must be removed to access a spared part is illustrated. Common hardware is shown as a letter callout.

### Section 6 General Procedures and Information

This section contains general information, change tag information, and general procedures.

### Section 7 Wiring Data

This section contains Block Schematic Diagrams (BSDs), Plug/Jack locations, Voltage Specifications, and I/O Module locations and information.

## Component Names

Names of parts that appear in the procedures may not be exactly the same as the names that appear on the part or listed in the Parts List. For example: a part called the Registration Assembly may appear on the Parts List as Assembly, REGI.

## How to Use this Manual

Always start with Service Call Procedures, Section 1. Perform Initial Actions and verify the problem, then follow the directions given.

### How to Differentiate Between Machine Variants

The machine configuration will be identified in this manual by the configuration identifiers 3052NI, 3260DI, 3260DNI and 3260DN.

The Phaser® 3052/3260 is Blue Angel certified with software configuration for up to 29 ppm capability. Refer to the User Guide, Parts List and Procedures for information specific to printer configuration.

When a procedure, parts list description or other reference is unique amongst different configurations of the machine, the appropriate configuration designator is indicated. Any artwork is also specific.

**NOTE:** *This manual services all configurations of the machine. Ignore references to options not installed on the machine.*

### Warnings, Cautions and Notes

#### WARNING

**A warning is used whenever an operating or maintenance procedure, practice, condition or statement, if not strictly observed, could result in personal injury.**

A translated version of all warnings is in [Translation of Warnings](#).

#### CAUTION

**A caution is used whenever an operation or maintenance procedure, practice, condition or statement, if not strictly observed, could result in damage to the equipment.**

**NOTE:** *A note is used where it is essential to highlight a procedure, practice, condition or statement.*



# Service Safety Summary

## General Guidelines

For qualified service personnel only: Refer also to Electrical Safety.

Avoid servicing alone: Do not perform internal service or adjustment of this product unless another person capable of rendering first aid or resuscitation is present.

Use care when servicing with power applied: Dangerous voltages may exist at several points in this product. To avoid personal injury, do not touch exposed connections and components while power is on. Disconnect power before removing the power supply shield or replacing components.

Do not wear jewelry: Remove jewelry prior to servicing. Rings, necklaces and other metallic objects could come into contact with dangerous voltages and currents.

## Electrical Safety

- Use the Power Cord supplied with the printer.
- Plug the Power Cord directly into a properly grounded electrical outlet.
- Do not use a ground adapter plug to connect the printer to an electrical outlet that does not have a ground connection terminal.
- Do not use an extension cord or power strip.
- Do not place the system in an area where people might step on the power cord.
- Do not place objects on the power cord.
- Do not block the ventilation openings. These openings are provided to prevent overheating of the printer.
- Do not drop paper clips or staples into the printer.

## Operational Safety

The printer and supplies were designed and tested to meet strict safety requirements. These include safety agency examination, approval, and compliance with established environmental standards.

Pay attention to these safety guidelines to ensure the continued, safe operation of the printer.

- Use the supplies specifically designed for your system. The use of unsuitable materials may cause poor performance and a possible safety hazard.
- Follow all warnings and instructions marked on, or supplied with, the system, options and supplies.

**NOTE:** *The Total Satisfaction Guarantee is available in the United States and Canada. Coverage may vary outside these areas; please contact your local representative for details.*

## Maintenance Safety

- Do not attempt any maintenance procedure that is not specifically described in the documentation supplied with the printer.
- Do not use aerosol cleaners. The use of supplies that are not approved may cause poor performance and could create a hazardous condition.
- Do not burn any consumables or routine maintenance items. For information on Xerox supplies recycling programs, go to [www.xerox.com/gwa](http://www.xerox.com/gwa).

## Warning Labels

Read and obey all posted warning labels. Throughout the printer, warning labels are displayed on potentially dangerous components. As you service the printer, check to make certain that all warning labels remain in place.

## Safety Interlocks

Make sure all covers are in place and all interlock switches are functioning correctly after you have completed a printer service call. If you bypass an interlock switch during a service call, use extreme caution when working on or around the printer.

## Electrostatic Discharge (ESD) Field Service Kit

The purpose of the ESD Protection Program is to preserve the inherent reliability and quality of electronic components that are handled by the Field Service Personnel. This program has been implemented as a direct result of advances in microcircuitry technology, as well as a new acknowledgment of the magnitude of the ESD problem in the electronics industry today.

This program will reduce Field Service costs that are charged to PWB failures. Ninety percent of all PWB failures that are ESD related do not occur immediately. Using the ESD Field Service Kit will eliminate these delayed failures and intermittent problems caused by ESD. This will improve product reliability and reduce callbacks.

The ESD Field Service Kit should be used whenever Printed Wiring Boards or ESD sensitive components are being handled. This includes activities like replacing or re-seating of circuit boards or connectors. The kit should also be used in order to prevent additional damage when circuit boards are returned for repair.

The instructions for using the ESD Field Service Kit can be found in [GP 7](#) in the General Procedures section of the Service Documentation.

## Product Safety Certification

This product is certified by various NRTLs/NCBs to the safety standards listed below:

UL60950-1/CSA22.2, No. 60950-1 (USA/Canada)

IEC60950-1 (CB Scheme)

## Reference Symbology

### Safety Symbols and Terminology

The following are examples of the terminology and symbols that are used in this documentation for an Electrostatic Device Caution, Laser Warning, and general Warnings, Cautions, or Notes.

#### WARNING

**Improper operation may result in injury to a person.**



#### CAUTION

*Improper operation may result in machine damage.*



#### Laser

Indicates that Laser safety precautions must be used.



#### Hot Surface

Indicates that a surface can be hot. Use caution when reaching in the machine to avoid touching the hot surface.



#### Electrical Current

Danger label indicates where electrical currents travel when the machine is closed and operating. Use caution when reaching in the machine.



#### ESD

Certain components in this product are susceptible to damage from Electrostatic Discharge. Observe all ESD procedures to avoid component damage.



The following reference symbols are used throughout the Xerox® Phaser® 3052/3260 Service Manual.

#### 1. Flag

- This symbol indicates a reference point into a circuit diagram from a RAP.

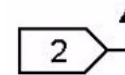

#### 2. Note

- This symbol is used to refer to notes that are found on the same page of a circuit diagram. A note is used whenever it is necessary to highlight an operating or maintenance procedure, a practice, condition, or statement.
- Hints or other information that may assist the user.



#### 3. Parts List

- This symbol, refers to the Parts List exploded view page where the part can be found.

#### 4. Adjustment

- This symbol refers to an adjustment procedure in the Repair/Adjustments section.



5. Test Point, Test Hole, Test Stake

- This symbol is used to indicate that a test point, test hole, or test stake is available for accessing the signal line. The prefix indicates whether the access is a test point (TP), test hole (TH), or test stake (TS).

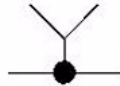

6. Commoning Point

- This symbol is used to refer to a location in the machine wiring where more than two wires are connected together at a single point.



7. Arrow

- This symbol points to the location to install, gain access to, or to release a component.



## Voltage Specifications

### AC and DC Voltages

Measurements of DC voltage must be made with reference to the specified DC Common, unless some other point is referenced in a diagnostic procedure. All measurements of AC voltage should be made with respect to the adjacent return or ACN wire (Table 1).

Table 1 Voltage Measurement and Specifications

VOLTAGE	SPECIFICATION
110 to 120 VAC 60Hz	100 to 132 VAC
Neutral to Ground VAC	0 VAC (+/- 5VAC)
+5 VDC	+5.05 VDC TO +5.25 VDC
+12 VDC	+11.4 VDC TO +12.6 VDC
-12 VDC	-11.4 VDC TO -12.6 VDC
+24 VDC	+22.8VDC TO +25.2 VDC
+36 VDC	+34.2 VDC TO +37.8 VDC

### Logic Voltage Levels

Measurements of logic levels must be made with reference to the specified DC Common, unless some other point is referenced in a diagnostic procedure (Table 2)

Table 2 Logic Levels

VOLTAGE	H/L SPECIFICATIONS
+5 VDC	H= +3.00 TO +5.25 VDC, L= 0.0 TO 0.8 VDC
+24 VDC	H= +23.37 TO +27.06 VDC, L= 0.0 TO 0.8 VDC

### DC Voltage Measurements in RAPs

The RAPs have been designed so that when it is required to use the DMM to measure a DC voltage, the first test point listed is the location for the red (+) meter lead and the second test point is the location for the black meter lead. For example, the following statement may be found in a RAP:

**There is +5 VDC from TP7 to TP68.**

In this example, the red meter lead would be placed on TP7 and the black meter lead on TP68.

Another example of a statement found in a RAP might be:

**There is -15 VDC from TP21 to TP33.**

In this example, the red meter lead would be placed on TP21 and the black meter lead would be placed on TP33.

If a second test point is not given, it is assumed that the black meter lead may be attached to the copier frame.

# Health and Safety Incident Reporting

## I. Summary

This section defines requirements for notification of health and safety incidents involving Xerox products (equipment and materials) at customer locations.

## II. Scope

Xerox Corporation and subsidiaries worldwide.

## III. Objective

To enable prompt resolution of health and safety incidents involving Xerox products and to ensure Xerox regulatory compliance.

## IV. Definitions

Incident:

An event or condition occurring in a customer account that has resulted in injury, illness or property damage. Examples of incidents include machine fires, smoke generation, physical injury to an operator or service representative. Alleged events and product conditions are included in this definition.

## V. Requirements

Initial Report:

1. Xerox organizations shall establish a process for individuals to report product incidents to Xerox Environment Health & Safety within 24 hours of becoming aware of the event.
2. The information to be provided at the time of reporting is contained in Appendix A (Health and Safety Incident Report involving a Xerox product).
3. The initial notification may be made by any of the following methods:
  - For incidents in North America and Developing Markets West (Brazil, Mexico, Latin American North and Latin American South):
    - Phone\* Xerox EH&S at: 1-800-828-6571.
    - Electronic mail Xerox EH&S at: USA.XEROX.EHS@xerox.com.
    - Fax Xerox EH&S at: 1-585-216-8817 [internet 8\*219-68817].
  - For incidents in Europe and Developing Markets East (Middle East, Africa, India, China and Hong Kong):
    - Phone\* Xerox EH&S at: +44 (0) 1707 353434 [internet 8\*668 3434]
    - Electronic mail Xerox EH&S at: EH&S-Europe@xerox.com
    - Fax Xerox EH&S at: +44 (0) 1707 353914 [internet 8\*668 3914]

\*Initial notification made by phone must be followed within 24 hours by a completed incident report and sent to the indicated electronic mail address or fax number.

**NOTE:** If sending a fax, please also send the original via internal mail.

Responsibilities for resolution:

1. Business Groups/Product Design Teams responsible for the product involved in the incident shall:
  - a. Manage field bulletins, customer correspondence, product recalls, safety retrofits.
  - b. Fund all field retrofits.
2. Field Service Operations shall:
  - a. Preserve the Xerox product involved and the scene of the incident inclusive of any associated equipment located in the vicinity of the incident.
  - b. Return any affected equipment/part(s) to the location designated by Xerox EH&S and/or the Business Division.
  - c. Implement all safety retrofits.
3. Xerox EH&S shall:
  - a. Manage and report all incident investigation activities.
  - b. Review and approve proposed product corrective actions and retrofits, if necessary.
  - c. Manage all communications and correspondence with government agencies.
  - d. Define actions to correct confirmed incidents.

## Regulatory Specifications

Xerox has tested this product to electromagnetic emission and immunity standards. These standards are designed to mitigate interference caused or received by this product in a typical office environment.

### United States (FCC Regulations)

The Xerox® Phaser® 3052/3260 has been tested and found to comply with the limits for a Class A digital device pursuant to Part 15 of the FCC Rules. These limits are designed to provide reasonable protection against harmful interference in a commercial installation. This equipment generates, uses, and can radiate radio frequency energy. If it is not installed and used in accordance with these instructions, it may cause harmful interference to radio communications. Operation of Class A equipment in a residential area is likely to cause harmful interference in which case the user will be required to correct the interference at his/her own expense. There is no guarantee that interference will not occur in a particular installation.

If this equipment does cause harmful interference to radio or television reception, which can be determined by turning the equipment Off and On, the user is encouraged to try to correct the interference by one or more of the following measures:

- Reorient or relocate the receiver.
- Increase the separation between the equipment and receiver.
- Connect the equipment into an outlet on a circuit different from that to which the receiver is connected.
- Consult the dealer or an experienced radio/television technician for help.

Any changes or modifications not expressly approved by Xerox could void the user's authority to operate the equipment. To ensure compliance with Part 15 of the FCC rules, use shielded interface cables.

### Canada (Regulations)

This Class A digital apparatus complies with Canadian ICES-003.

Cet appareil numérique de la classe A est conforme à la norme NMB-003 du Canada.

### European Union

CE Mark



The CE mark applied to this product symbolizes Xerox's declaration of conformity with the following applicable Directives of the European Union as of the dates indicated:

**Figure 1 CE Symbol**

December 12, 2006: Low Voltage Directive 2006/95/EC

December 15, 2004: Electromagnetic Compatibility Directive 2004/108/EC

This product, if used properly in accordance with the user's instructions, is neither dangerous for the consumer nor for the environment.

To ensure compliance with European Union regulations, use shielded interface cables.

A signed copy of the Declaration of Conformity for this product can be obtained from Xerox.

## Translation of Warnings

### WARNING

Switch off the electricity to the machine. Disconnect the power cord from the customer supply while performing tasks that do not need electricity. Electricity can cause death or injury. Moving parts can cause injury.

**DANGER :** Mettez la machine hors tension. Déconnectez le cordon d'alimentation de l'alimentation du client lorsque vous réalisez des tâches qui ne nécessitent pas d'électricité. L'électricité peut être à l'origine de blessures, voire d'un accident mortel. Les pièces amovibles peuvent être à l'origine de blessures.

**AVVERTENZA:** Spegner la macchina. Scollegare il cavo di alimentazione dall'alimentatore quando si eseguono attività che non richiedono elettricità. L'elettricità può causare morte o lesioni personali. Le parti in movimento possono causare lesioni personali.

**VORSICHT:** Schalten Sie die Stromversorgung der Maschine ab. Ziehen Sie das Stromkabel ab, wenn Sie Aufgaben ausführen, für die keine Stromversorgung benötigt wird. Stromschläge können Todesfällen oder Verletzungen verursachen. Bewegliche Teile können zu Verletzungen führen.

**AVISO:** Apague la electricidad de la máquina. Desconecte el cable de alimentación eléctrica de la toma de pared mientras esté realizando tareas que no necesiten corriente. La electricidad puede causar daños o la muerte. Las partes móviles pueden causar daños.

### WARNING

Do not work in a confined space. 1 m (39 inches) space is needed for safe working.

**DANGER :** Ne pas travailler dans un espace restreint. 1 mètre d'espace est nécessaire pour un dépannage en toute sécurité.

**AVVERTENZA:** Non lavorare in uno spazio limitato; è necessario uno spazio di almeno un metro attorno alla macchina per la sicurezza dell'operatore.

**VORSICHT:** Nur mit ausreichendem Bewegungsspielraum (1 m) arbeiten.

**AVISO:** No trabaje en un espacio reducido. Se necesita 1 metro de espacio para trabajar con seguridad.

### WARNING

Use safe handling procedures when removing the module. Refer to GP 16. The module is heavy.

**DANGER:** Conformez-vous aux procédures de manipulation de sécurité pour le retrait du module. Reportez-vous à GP 16. Le module est lourd.

**AVVERTENZA:** Utilizzare procedure di gestione sicure durante la rimozione del modulo. Vedere GP 16. Il modulo è pesante.

**VORSICHT:** Verwenden Sie sichere Vorgehensweisen zum Entfernen des Moduls. Siehe auch GP 16. Das Modul ist sehr schwer.

**AVISO:** Utilice los procedimientos de seguridad cuando elimine el módulo. Consulte el GP 16. El módulo es pesado.

### WARNING

Follow the service procedure exactly as written. Use of controls or adjustments other than those specified in this manual, may result in an exposure to invisible laser radiation. During servicing, the invisible laser radiation can cause eye damage if looked at directly.

**DANGER :** Les procédures de dépannage doivent être suivies à la lettre. Si les réglages ou vérifications ne sont pas effectués suivant les instructions de ce manuel, il peut y avoir un risque d'exposition dangereuse au faisceau laser. Celui-ci peut provoquer des lésions oculaires s'il est observé directement.

**AVVERTENZA:** Eseguire le procedure di servizio esattamente come descritto. L'utilizzo di dispositivi di controllo o di registrazione diversi da quelli riportati in questo manuale potrebbe comportare un'esposizione a radiazioni laser invisibili. Tali radiazioni possono danneggiare gli occhi se si guarda direttamente il fascio laser durante gli interventi di servizio.

**VORSICHT:** Die Wartungsarbeiten genau den Anweisungen entsprechend durchführen. Der Umgang mit Steuer- oder Bedienelementen, deren Verwendung nicht ausdrücklich in diesem Handbuch angewiesen wurde, kann dazu führen, dass unsichtbare Laserstrahlung frei gesetzt wird. Direkter Blickkontakt mit dem Laserstrahl kann bleibende Augenschäden verursachen.

**AVISO:** Siga los procedimientos de mantenimiento tal como están descritos. El uso de controles o ajustes no especificados en este manual puede tener como resultado la exposición a radiación láser invisible. Durante las operaciones de mantenimiento, la radiación de láser invisible puede causar daños en los ojos si se mira directamente a ella.

### WARNING

USA and Canada. Do not install this machine in a hallway or exit route that does not have 1.12 m (44 inches) of space additional to the normal space requirements in front of the machine. To conform with fire regulations this additional 1.12 m (44 inches) of space is needed in front of the machine in hallway and exit routes.

**DANGER :** États-Unis et Canada. Si cette machine est installée dans un couloir ou une voie de sortie, 1,12 m (44 pouces) d'espace supplémentaire à l'espace normal doit être disponible devant la machine conformément aux normes de sécurité d'incendie.

**AVVERTENZA:** N/A

**VORSICHT:** N/A

**AVISO:** Estados Unidos y Canadá. No instale esta máquina en un corredor o ruta de salida que no tenga 1.12 m (44 pulgadas) de ancho delante de la máquina, sin incluir el espacio que ocupe la máquina. Este espacio adicional de 1.12 m (44 pulgadas) delante de la máquina en corredores y rutas de salida es necesario para cumplir los requisitos de las normas sobre incendios.

## WARNING

Use only Xerox materials and components. This product is safety certified using Xerox materials and components. The use of non Xerox materials and components may invalidate the safety certificate.

**DANGER :** N'utilisez que des matières premières et des composants Xerox. La sécurité du produit est assurée dans le cadre de son utilisation avec des matières premières et des composants Xerox. L'utilisation de matières premières et de composants autres que ceux de Xerox risque d'invalider le certificat de sécurité.

**AVVERTENZA:** Utilizzare solo materiali e componenti Xerox per avvalersi della certificazione di protezione. L'utilizzo di materiali e componenti non Xerox può rendere nulla la certificazione di protezione.

**VORSICHT:** Verwenden Sie nur Materialien und Komponenten von Xerox. Dieses Produkt besitzt die Sicherheitszertifizierung bei Verwendung von Xerox-Materialien und -Komponenten. Die Verwendung von Materialien und Komponenten anderer Hersteller setzt möglicherweise das Sicherheitszertifikat außer Kraft.

**AVISO:** Utilice solo los materiales y componentes Xerox. Este producto dispone de un certificado de seguridad si se utilizan los materiales y componentes Xerox. Este certificado de seguridad no será válido si se utilizan materiales y componentes que no sean de Xerox.

## WARNING

Do not touch the fuser while it is hot.

**DANGER :** Ne pas toucher au four pendant qu'il est encore chaud.

**AVVERTENZA:** Non toccare il fonditore quando è caldo.

**VORSICHT:** Fixierbereich erst berühren, wenn dieser abgekühlt ist.

**AVISO:** No toque el fusor mientras está caliente.

## Tag Usage

### Tags

If different parts or actions exist because of a modification, the Tag number will identify the appropriate part or action.

- Example 1). Tag xx: PWB. . .
- Example 2) PWB (Tag xx) . . .

### Tag Symbols

This symbol is used to show a particular part or area of a figure that has been modified by the Tag number within the circle.

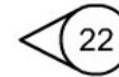

This symbol is used to show a particular part or area of a figure that has not been modified by the Tag number within the circle.



This symbol is used to show a Tag change has modified an area of the terminal.



This symbol is used to show a Tag change has not modified an area of the terminal.



## Phaser® 3052/3260 Overview

Refer to the Phaser® 3250/3260 User Guide, Product Configuration Section 1 for detailed descriptions and illustrations of Control Panel functions, machine features and options.

**Table 1 Product Configurations**

<b>Component</b>	<b>Phaser 3052NI</b>	<b>Phaser 3260DI</b>	<b>Phaser 3260DNI</b>	<b>Phaser 3260DN</b>
Paper Tray - 250 Sheets	Standard	Standard	Standard	Standard
Manual Feed Slot - 1 sheet	Standard	Standard	Standard	Standard
Output Tray - 150 Sheets	Standard	Standard	Standard	Standard
AirPrint	Standard	Standard	Standard	Standard
Google Cloud Print	Standard	Standard	Standard	Standard
Network Printing	Standard	Not Applicable	Standard	Standard
USB Device	Standard	Standard	Standard	Standard
USB Host	Not Applicable	Not Applicable	Not Applicable	Not Applicable
Wi-Fi	Standard	Standard	Standard	Not Applicable
Wi-Fi Direct™	Standard	Standard	Standard	Not Applicable



---

# 1 Service Call Procedures

## Call Flow

Service Call Overview .....	1-3
Safety Precautions .....	1-3
SCP 01 Introduction to Service Call Procedures .....	1-4
SCP 02 Initial Actions.....	1-4
SCP 03 Corrective Actions.....	1-5
SCP 04 Final Actions .....	1-5
HFSI's .....	1-6



## Service Call Overview

This section provides an overview of actions a service technician should take when servicing a machine. Refer to the checklist below as a guide for steps to take when troubleshooting problems with the printer. Follow all precautions listed in the Safety Precautions section.

1. Identify the problem
  - Verify that the problem exists.
  - Record any error codes.
  - Print both customer and test prints.
  - Make note of any image quality problems in the test prints.
  - Observe if any unusual odors or noises coming from the printer.
  - Ensure that the AC input power is within specifications.
  - From the Diagnostics Mode, print an Error Information Report.
2. Inspect and clean the printer
  - Disconnect and inspect the power cord.
  - Inspect the interior of the printer. Remove any debris or contamination.
  - Inspect the printer for damaged wires, loose connections toner leakage or any other worn or damaged parts.
3. Find the cause of the problem.
  - Use troubleshooting procedures to find the root cause of the problem
  - Use diagnostics to check the printer and components
  - Use the BSDs and wiring diagrams to locate test points.
  - Take voltage readings as instructed in the troubleshooting procedure.
4. Correct the problem
  - Use the Parts List to locate part numbers.
  - Use the Repair Procedures to replace parts.
5. Final Actions
  - Test the printer to verify that the problem has been corrected and that there are no additional problems.

## Diagnostic Mode

The Xerox® Phaser® 3020 printer has built-in diagnostics to test components, display status and some NVM access. The diagnostic tests are accessed through the Embedded Diagnostic Control (EDC) tool. Refer to the Xerox® Phaser® 3020 User Guide for detailed instructions on using the Control Panel buttons and menus. Refer to Section 6 for diagnostic test menus.

## Safety Precautions

**Ensure that all Cautions and Warnings in the service procedures are followed.**

Failure to follow the following instructions could cause an electrical shock or fire hazard.

- Only use the Power Cord supplied with this product.  
Do not allow the Power Cord to become twisted, bent, or damaged.
- Do not allow liquids to spill on or into the machine.
- Do not allow paper clips, pins or other objects to fall into the machine.
- When replacing the SMPS PWB wait 5 minutes after unplugging the Power Cord before removing the PWB. This allows the PWB to discharge, preventing electrical shock.

### Laser Safety

- The Laser system is designed so there is never human access to the Laser radiation during normal operation, user maintenance, or service maintenance.
- Do not bypass or disable any laser safety devices or attempt to service the Laser.

## SCP 01 Introduction to Service Call Procedures

### Purpose

Service Call Procedures (SCP) are the guide to performing a service call on the Xerox® Phaser® 3020.

The Operator has been trained in the use of the Customer Help Information located in the Xerox® Phaser® 3020 User Guide to help analyze the fault. The Problem Solving section directs the Operator in the following:

- Faults indicated by a Status Code or UI message
- Web Registration Module problem solving
- Image quality defect initial actions
- Image quality defect diagnosis
- Image quality fault code problem solving

If the Operator is unable to resolve the problem, they initiate a service call by contacting The Xerox Support Center at: [www.xerox.com/support](http://www.xerox.com/support).

For NASG, the Xerox® Phaser® 3020 Printer customer will initiate a service call by contacting The Xerox Support Center at [www.xerox.com/support](http://www.xerox.com/support).

For XE, the customer will initiate a service call by contacting the Welcome Centre.

### SCP 02 Initial Actions

The purpose of Initial Actions is to gather information and organize the service call. The customer is questioned, and the complaint is verified.

All anticipated service actions are classified as primary or secondary. Primary service actions are those actions that directly relate to the reason for the call.

### SCP 03 Corrective Actions

Corrective Actions are the diagnostic and repair activities required to correct the problem that initiated the service call (primary actions), as well as any other problems or secondary actions identified in Initial Actions.

When performing maintenance actions, either scheduled or unscheduled, always consider the customer's print schedule and whether they are in a highly time-sensitive print run, or in a less time-sensitive print run. The customer's current mode of operation will determine the service actions on Unscheduled Maintenance (UM) calls. The objective of all service actions is to integrate the Xerox service process with the customer's printing process in a manner that maximizes customer equipment up-time and productivity during periods of time-sensitive print runs.

This is one of the tenets of Overall Equipment Effectiveness (OEE).

## SCP 02 Initial Actions

### Purpose

The purpose of the Initial Actions is to help organize the service call. Customer input, machine observations and print samples are all used to gather information about the condition of the system. Gather a list of symptoms, error codes, or other information concerning the problem that the customer may provide. This information may help identify and correct intermittent or unusual problems.

During each service call, perform all Primary Maintenance Activities, then decide if Secondary Maintenance Activities are needed.

- Primary Maintenance Activities are actions performed which relate to the customer's complaint.
- Secondary Maintenance Activities are any activities identified during the service call which are not related to the primary activity, but may lead to a future service call or otherwise negatively affect the customer's satisfaction.

Before deciding to perform any secondary maintenance, first determine if the customer is in a time-sensitive print run. If so, perform only those actions required to ensure completion of the run, and defer all other actions-- including HFSI's that are not required to complete the print run. The objective of any service call during a time-sensitive print run is to return the system to production as soon as possible.

Before performing any secondary maintenance actions, first inform the customer of what secondary actions are indicated and the system down time required. You may want to return on another, mutually agreeable time to perform the secondary maintenance activity/actions.

Likewise, for any secondary maintenance actions deferred during a time-sensitive print run, inform the customer of what remaining secondary actions are indicated and the down time required. Coordinate with the customer's print schedule to determine a mutually-agreeable time frame to complete these activities.

### Procedure

1. Discuss the problem with the customer.
2. If the problem is IQ related, run prints to verify that the problem is present.
3. Determine if there are any bulletins, or Eureka tips relating to the Customer's primary problem. Bulletins are on Eureka and are searchable with SearchLite.
4. When all information has been gathered, and all anticipated service actions have been classified as primary or secondary, proceed to SCP 03 Corrective Actions.

## SCP 03 Corrective Actions

### Purpose

The Corrective Actions procedure will direct you to the appropriate section of the service manual to diagnose and repair the primary problem, and provides you with the information required to identify any due HFSI items.

### Procedure

1. Review the Customer Log Book, as well as the Service Log Book, to determine if any previously performed activities could be causing the problem.
2. Using the Customer Log Book and the Service Log Book, review the HFSI's to identify any due HFSI's. Clean/replace **only** components that are due and you think may be contributing to the problem.

### System Fault Analysis

1. If the problem is a fault code, determine if the fault code is a Printer fault code or a DFE fault code.
  - a. If the problem is a Printer fault code:
    - Check for associated fault codes that have the same or nearly the same timestamp as the primary fault code
    - Troubleshoot fault codes with the lowest chain number first
2. If the problem is IQ related, refer to Section 3 Image Quality Entry RAP.
3. When the primary problem is resolved, proceed to Final Actions.

## SCP 04 Final Actions

### Purpose

Final Actions verify total operation of the machine, ensures that the HFSI's are completed, and provides a Machine Site Checklist to complete the call.

### Procedure

1. Print a Sample Job and verify with the operator the total operation of the machine. If any problems are identified, return to SCP 03 Corrective Actions.
2. Perform SCP Call Closeout in Diagnostics.
3. Complete the Machine Site Checklist:
  - Check the customer consumables.
  - Service tools are properly stored and secured.
  - Verify the access to the circuit breakers is clear.
  - Check that all the doors and panels are in place and interlock cheaters are removed and secured.
  - Verify that all mandatory retrofits have been installed. If required, set a time with the customer to install any mandatory retrofits.

## HFSI's

### Customer and Service HFSI's

As with other CSE actions, these actions should be performed according to customer run requirements. Some actions may be deferred to a Xerox Initiated activity, taking into consideration any risks with deferring those actions.

To track HFSI items, a tracking sheet is provided. The tracking sheets are located in a pocket inside the front cover of the:

- Printer Service Log Book (CSE) - tracking sheet **Service Maintenance Intervals**.

- Customer Maintenance Log Book (operator) - tracking sheet **Service Maintenance Intervals**.

If necessary, and if the customer agrees, clean/replace any secondary HFSI's that are due or may cause a return service call.

Be sure to continually update and review the Printer Service Log and Customer Maintenance Log for all maintenance actions, to avoid any unnecessary actions that increase customer equipment down times, service time, and costs.

**Table 1 Customer/Service HFSI's**

HSFI Item	Action	Customer	Service	Reference	Interval	Notes
Toner Cartridge	Replace	X		N/A	1,000 standard / 3,000 high yield (approx. impressions)	Initial toner cartridge yield is approximately 1,500
Drum Cartridge (OPC)	Replace	X		N/A	10,000	
Transfer Roller	Replace		X	REP 1.16	100,000	
Forward Roller	Replace		X	REP 1.15	50,000	
Retard Roller	Replace		X	REP 1.12	50,000	
Pick-up Roller	Replace		X	REP 1.15	50,000	
Fuser	Replace		X	REP 1.24	100,000	

## 2 Status Indicator RAPs

01-100 Front Cover Open Fault .....	2-3
03-410 Paper Mismatch at Tray 1 .....	2-3
03-450 Paper Mismatch at Manual Feed Slot.....	2-4
03-900 Main PWB Motor Control Chip Fault.....	2-4
04-500 Main Drive (BLDC) Motor Start Fault.....	2-5
06-100 / 200 Laser Module (LSU) Motor Fault.....	2-5
07-110 Paper Tray 1 Empty Fault.....	2-6
07-130 Paper Jam in Tray 1 Fault.....	2-7
07-500 Manual Feed Slot Paper Empty Fault.....	2-8
07-530 Paper Feed Fault - Manual Feed Slot.....	2-8
08-100 Paper Feed Fault - Tray 1 .....	2-9
08-500 Paper Jam in Exit Area Fault .....	2-9
08-700 Output Tray Full Fault .....	2-10
08-600 Paper Jam in Duplex Area Fault.....	2-10
09-100 Toner Cartridge Near End of Life Fault.....	2-11
09-300 Imaging Unit Near End of Life Fault.....	2-11
09-350 Toner Cartridge End of Life Fault.....	2-12
09-400 Imaging Unit End of Life Fault.....	2-12
09-550 Toner Cartridge Undetected Fault .....	2-13
09-800 Incompatible Toner Cartridge Fault .....	2-13
09-900 Imaging Unit Undetected Fault .....	2-14
10-100 Fuser Temperature (Open) Fault.....	2-14
10-200/ 300 Fuser Under/ Over Temperature Fault.....	2-15
17-100 IP Conflict Error Fault.....	2-15
17-310 Communication Error (Main PWB to Wireless PWB) Fault.....	2-16
17-700 / 710 BOOTP Error Fault .....	2-16
17-800 / 810 DHCP Error Fault.....	2-17
17-900 802.1X Network Authentication Error Fault.....	2-17
17-910 Firmware Upgrade Fault .....	2-18





## 01-100 Front Cover Open Fault

The front cover is open or the cover open switch is defective.

**BSD-Reference:** 1.1 AC/Low Voltage and High Voltage Power/Interlocks

### Initial Actions

Ensure that the front cover is completely closed.

### Procedure

#### **WARNING**

**Do not perform repair activities with the power on or electrical power supplied to the machine. The machine could activate and cause serious personal injury when the power is on or electrical power is supplied.**

**DANGER: Ne pas effectuer de dépannage avec le contact principal activé ou avec l'alimentation électrique appliquée à la machine: celle-ci pourrait démarrer et causer de graves blessures.**

**AVVERTENZA: Non effettuare alcuna riparazione con la macchina accesa o con l'alimentazione elettrica inserita. La macchina potrebbe avviarsi all'improvviso e causare gravi ferite.**

**VORSICHT: Es dürfen keine Reparaturarbeiten durchgeführt werden, solange das Gerät eingeschaltet oder mit der Stromquelle verbunden ist. Das Gerät kann u.U in den Aktiv-Zustand übergehen und somit erhebliche körperliche Schäden verursachen.**

**AVISO: No realice reparaciones con la máquina encendida o conectada a la corriente. La máquina podría activarse y ocasionar daños personales graves.**

Check the Front Cover Open Switch connection to the Main PWB. **The connection is good.**

- |          |   |
|----------|---|
| <b>Y</b> | <b>N</b>  |
|          | • Check that there is no contamination present. |
|          | • Check for an open or short circuit            |
|          | • Replace the LVPS/HVPS (REP 1.2), PL 4.1.      |

Check the connection between the Main PWB and the HVPS. **The connection is secure.**

- |          |  |
|----------|--|
| <b>Y</b> | <b>N</b>   |
|          | • Check that there is no contamination present.            |
|          | • Check for broken or defective wires or cables.           |
|          | • Secure the connection between the Main PWB and the HVPS. |

Replace the HVPS PWB (REP 1.7), PL 4.1.

## 03-410 Paper Mismatch at Tray 1

The size setting for the Paper Tray does not match the paper size loaded in the tray.

**BSD-Reference:** 3.1A Communications

### Initial Actions

- Check the media size settings for the tray from the Control Panel.
- Adjust the Paper Tray Guides to match the size of the paper that is loaded into the tray.
- Place the correct size paper into the tray for the tray size setting.

### Procedure

1. Switch Off the power, then switch On the power.
2. If the problem continues, replace the Main PWB (REP 1.8), PL 1.1.

## 03-450 Paper Mismatch at Manual Feed Slot

The size setting for the Manual Feed Slot does not match the paper size loaded.

**BSD-Reference:** 3.1A Communications

### Initial Actions

- Using Easy Printer Manager, Device Settings, check the media size settings for the tray.
- Adjust the Paper Tray Guides to match the size of the paper that is loaded into the tray.
- Place the correct size paper into the tray for the tray size setting.

### Procedure

1. Switch Off the power, then switch On the power.
2. If problem continue, replace the Main PWB ([REP 1.8](#)), [PL 1.1](#).

## 03-900 Main PWB Motor Control Chip Fault

The Motor Control Chip on the Main PWB is not functioning normally.

**BSD-Reference:** 3.1A, 3.1B Communications

### Procedure

1. Switch Off the power then switch On the power.
2. If problem continues, replace the Main PWB ([REP 1.8](#)), [PL 1.1](#).

## 04-500 Main Drive (BLDC) Motor Start Fault

The Main Drive (BLDC) Motor did not start within the specified time after the ready signal was sent.

**BSD-Reference:** 4.1 Main Drive

### Initial Actions

- Switch Off the power, then switch On the power.

### Procedure

Enter Diagnostic (EDC) Mode. Using the arrows, scroll to [DC330 Test Routines, 100 Moto] to start the motor. **The motor rotates.**

**Y N**  
Remove the Right Cover [REP 1.2](#) and check the motor connector on the Main PWB. **The connector on the Main PWB is securely connected.**

- Y N**
- Check that there is no contamination present.
  - Check for broken and defective wires or cables.
  - Securely reconnect the motor connector.

Manually rotate the Main Drive Unit. **The Main Drive Motor rotates freely.**

**Y N**  
Replace the Main Drive Unit ([REP 1.10](#)), [PL 4.6](#).

The Main PWB is defective.

- Replace the Main PWB ([REP 1.8](#)), [PL 1.1](#).

If the problem persists, replace the Main PWB, ([REP 1.8](#)), [PL 1.1](#).

## 06-100 / 200 Laser Module (LSU) Motor Fault

The machine has detected that the Laser Module Drive Motor is not working correctly.

**BSD-Reference:** 6.1 LSU (ROS)

### Procedure

#### WARNING

**Do not perform repair activities with the power on or electrical power supplied to the machine. The machine could activate and cause serious personal injury when the power is on or electrical power is supplied.**

**DANGER: Ne pas effectuer de dépannage avec le contact principal activé ou avec l'alimentation électrique appliquée à la machine: celle-ci pourrait démarrer et causer de graves blessures.**

**AVVERTENZA: Non effettuare alcuna riparazione con la macchina accesa o con l'alimentazione elettrica inserita. La macchina potrebbe avviarsi all'improvviso e causare gravi ferite.**

**VORSICHT: Es dürfen keine Reparaturarbeiten durchgeführt werden, solange das Gerät eingeschalten oder mit der Stromquelle verbunden ist. Das Gerät kann u.U in den Aktiv-Zustand übergehen und somit erhebliche körperliche Schäden verursachen.**

**AVISO: No realice reparaciones con la máquina encendida o conectada a la corriente. La máquina podría activarse y ocasionar daños personales graves.**

#### WARNING

**Use eye protection when performing the following procedure. Failure to wear eye protection could result in serious personal injury.**

**DANGER: Porter des lunettes de sécurité pendant la procédure suivante. À défaut, de graves blessures peuvent se produire.**

**AVVERTENZA: Indossare occhiali di protezione durante la seguente procedura. In caso contrario, si possono provocare gravi ferite.**

**VORSICHT: Folgende Verfahren dürfen nicht ohne Schutzbrille angewandt werden. Die Nichteinhaltung dieser Regel kann zu ernsthaften körperlichen Verletzungen führen.**

**AVISO: Use gafas de protección para realizar el procedimiento siguiente. No proteger los ojos puede ocasionar daños personales graves.**

Enter Diagnostic (EDC) Mode. Select: **[DC330 Component Control, 110 LSU, LSU Mot1 Run]** to test the LSU motor. **The motor runs.**

Y N

Check the Main Wire Harness and connectors on the Laser Module. **The connections are secure.**

Y N

- Check that there are no broken or defective wires and that no contamination is present
- Disconnect and securely reconnect the harness.

Check the harness for a short circuit or open circuit. **The harness is OK.**

Y N

- Check that there are no broken or defective wires and that no contamination is present
- Replace the Harness (REP 1.11), PL 4.1.

Replace the LSU Laser Module (REP 1.11), PL 4.1.

Go to SCP 04 Final Actions.

## 07-110 Paper Tray 1 Empty Fault

The Tray Empty Sensor failed to detect paper in the tray

**BSD-Reference:** 7.1 Paper Feed and Registration

### Initial Actions

Ensure that paper is loaded in the tray. Clear any jammed sheets. Refer to Section 7: Troubleshooting in the Xerox® Phaser® 3052/3260 User Guide for detailed instructions on clearing paper jams.

### Procedure

Check the Paper Tray Empty Sensor Actuator. **The actuator moves freely and is undamaged.**

Y N

Replace the Paper Tray Empty Sensor Actuator (REP 1.14), PL 4.5.

Enter Diagnostic (EDC) Mode. Select **[DC330 Test Routines, 102 Sensor, Tray 1 Empty]** to block and clear the Tray 1 Empty Sensor. **The Sensor Signal changes.**

Y N

Check for 3.3 VDC at the Paper Tray Empty Sensor. **Voltage is present at the Paper Tray Empty Sensor.**

Y N

Check for 3.3 VDC at the Main PWB. **Voltage is present at the Main PWB.**

Y N

Check that all voltages are present between the HVPS PWB and the Main PWB. **The voltages between the HVPS PWB and the Main PWB are present.**

Y N

- Replace the HVPS PWB (REP 1.7), PL 4.1.
- Replace the Main PWB (REP 1.8), PL 1.1.

Replace the Paper Tray Empty Sensor PL 4.5.

Replace the Paper Tray Empty Sensor PL 4.5.

Replace the Paper Tray Empty Sensor PL 4.5.

If the problem is intermittent, check the circuit of the Tray Empty Sensor.

## 07-130 Paper Jam in Tray 1 Fault

A paper jam has occurred in Tray 1.

**BSD-Reference:** 7.1 Paper Feed and Registration

### Initial Actions

- Remove jammed paper from Tray 1 area. Refer to Section 7: Troubleshooting, in the Xerox® Phaser® 3052/3260 User Guide for detailed instructions on clearing paper jams.
- Clear the paper path of any debris or obstructions.
- Ensure the loaded paper is within machine specifications. Refer to Section 6 General Procedures for product specifications.

### Procedure

Remove Tray 1 and ensure that guides are set correctly. **The paper is loaded correctly in the tray.**

**Y N**  
Align the paper in Tray 1 then reinsert the tray.

Check the position of the jammed sheet. **The lead edge reached the Retard Roll.**

**Y N**  
Enter Diagnostic (EDC) Mode. Select: **[DC330 Test Routines, 102-Sensor, Feed Sens]** to block and clear the Paper Feed Sensor. **The sensor is signal changes.**

**Y N**  
Check for 3.3 VDC on the Feed Sensor PWB. **The voltage is present at the connector on the Feed Sensor PWB.**

**Y N**  
Check for 3.3 VDC on the Main PWB. **The voltage is present on the Main PWB.**

**Y N**  
Check that all voltages are present between the HVPS PWS and the Main PWB. **The voltages between the HVPS PWB and the Main PWB are present.**

- Y N**
- Replace the HVPS PWB (REP 1.7), PL 4.1.
  - Replace the Main PWB (REP 1.8) , PL 1.1.

Replace the Feed Sensor PWB (REP 1.14), PL 4.4.

Replace the Feed Sensor PWB (REP 1.14), PL 4.4.

Replace the Feed Sensor PWB (REP 1.14), PL 4.4.

In Diagnostics, go to **[101-Clutch, Tray 1 Pick up]** to energize the clutch. **The clutch engages.**

**Y N**  
Check for 24 VDC on the Paper Feed PWB. **The voltage is present at the connector on the Paper Feed PWB.**

**A B**

**Y N**  
Check all voltages are present between the HVPS PWB and the Main PWB. **The voltages between the HVPS PWB and the Main PWB are present**

**Y N**

- Replace the HVPS PWB (REP 1.7), PL 4.1.
- Replace the Main PWB (REP 1.8), PL 1.1.

Replace the Feed Sensor PWB (REP 1.14), PL 4.4.

Replace the Feed Clutch (REP 1.13), PL 4.1.

Perform SCP Final Actions.

Remove any jammed paper. Check the following for wear or damage and replace as required:

- Retard Roller, [REP 1.12], PL 4.5.
- Pick up (Feed) and Forward Roll Assembly, (REP 1.15) , PL 4.5.

**A B**

## 07-500 Manual Feed Slot Paper Empty Fault

The Registration Sensor failed to detect paper in the Manual Feed Slot.

**BSD-Reference:** 7.1 Paper Feed and Registration

### Initial Actions

Ensure that paper is loaded in the tray. Clear any jammed sheets. Refer to Section 7: Troubleshooting, in the Xerox® Phaser® 3052/3260 User Guide for detailed instructions on clearing paper jams.

### Procedure

Check the Registration Sensor actuator. **The actuator moves freely and is undamaged.**

- |   |  |
|---|--|
| Y | N  |
|   |  |
|   | • Check that no contamination is present.                      |
|   | • Replace the Registration Sensor Actuator (REP 1.14), PL 4.4. |

Enter Diagnostics (EDC) Mode [DC330 Test Routines, 102-Sensor, Registration Sensor]. to block and clear the Registration Sensor. **The sensor signal changes.**

Y	N
	Check for 3.3 VDC on the Main PWB. <b>The voltage is present on the Main PWB.</b>

- |   |   |
|---|---|
| Y | N   |
|   |   |
|   | • Replace the HVPS PWB (REP 1.7), PL 4.1. |
|   | • Replace the Main PWB (REP 1.8), PL 1.1. |

Replace the Feed Sensor PWB (REP 1.14), PL 4.4.

Perform SCP Final Actions.

## 07-530 Paper Feed Fault - Manual Feed Slot

The lead edge was not detected by the Paper Feed Sensor.

**BSD-Reference:** 7.1 Paper Feed and Registration

### Initial Actions

Clear any jammed sheets. Refer to Section 7: Troubleshooting, in the Xerox® Phaser® 3052/3260 User Guide for detailed instructions on clearing paper jams.

### Procedure

Check the position of the jammed sheet. **The lead edge reached the Retard Roll.**

Y	N
	Enter Diagnostic (EDC) Mode. Select: [DC330 Test Routines, 102-Sensor, Feed Sens] to block and clear the Paper Feed Sensor. <b>The sensor is OK.</b>

- |   |   |
|---|---|
| Y | N   |
|   |   |
|   | • Check for an open or short circuit.         |
|   | • Replace the Feed Sensor (REP 1.14), PL 4.4. |

In Diagnostic Mode, select: [101-Clutch, Registration] to engage the drive to pick up paper from tray 1. **The clutch engages.**

- |   |  |
|---|--|
| Y | N  |
|   |  |
|   | • Check for an open or short circuit.                          |
|   | • Replace the Tray 1 Pick up (Feed) Clutch (REP 1.13), PL 4.1. |

Perform SCP Final Actions.

Check the Paper Feed actuator. **The actuator moves freely and is undamaged.**

Y	N
	Replace the Paper Feed actuator, (REP 1.14), PL 4.4.

Inspect the Paper Feed Sensor for damage. **The sensor is OK.**

- |   |   |
|---|---|
| Y | N   |
|   |   |
|   | • Check for an open or short circuit.                   |
|   | • Replace the Paper Feed Sensor PWB (REP 1.14), PL 4.4. |

Check the circuit of the Paper Feed PWB.

## 08-100 Paper Feed Fault - Tray 1

The lead edge was not detected by the Paper Feed Sensor.

**BSD-Reference:** 7.1 Paper Feed and Registration

### Initial Actions

Clear any jammed sheets. Refer to Section 7: Troubleshooting, in the Xerox® Phaser® 3052/3260 User Guide for detailed instructions on clearing paper jams.

### Procedure

Check the Paper Feed Sensor Actuator for damage or binding. **The Actuator moves freely.**

**Y N**  
Replace the Paper Feed Sensor Actuator (REP 1.14), PL 4.4.

Check the position of the jammed sheet. **The lead edge reached the Retard Roll.**

**Y N**  
Enter Diagnostic (EDC) Mode. Select: **[DC330 Test Routines, 101-Clutch, Tray 1 Pick up]** to engage the drive to pick up paper from tray 1 **The clutch engages.**

- Y N**
- Check the circuit between the Feed clutch and the Main PWB for an open or short circuit.
  - Replace the Tray 1 Pick up (Feed) Clutch (REP 1.13), PL 4.1.

Check the Paper Feed Sensor Actuator. **The actuator moves freely.**

**Y N**  
Replace the Paper Feed Sensor Actuator (REP 1.14), PL 4.4.

In Diagnostics Mode. Select: **[102-Sensor, Feed Sens]** to block and clear the Paper Feed Sensor. **The signal changes.**

- Y N**
- Check that there is no contamination or damage on any connectors from the Feed Sensor PWB to the HVPS PWB. Repair as necessary.
  - Replace the Paper Feed Sensor PWB (REP 1.14), PL 4.4.

Perform SCP Final Actions.

If the problem is intermittent check the cables for binding.

## 08-500 Paper Jam in Exit Area Fault

The machine has detected a paper jam in the Exit Area.

**BSD-Reference:** 7.1 paper Feed and Registration, 10.2 Print Exit

### Initial Actions

Open the Rear Cover and remove jammed sheets from exit area. Refer to Section 7: Troubleshooting, in the Xerox® Phaser® 3052/3260 User Guide for detailed instructions on clearing paper jams.

Check the Paper Guides for proper position.

Check the Duplex Gate and Spring for damage. Ensure that the gate is seated correctly and moves freely without binding.

### Procedure

Enter Diagnostic (EDC) Mode. Select: **[DC330 Test Routines, 102-Sensor, Exit Sens]** to block and clear the Exit Sensor. **The Exit Sensor is OK.**

- Y N**
- Check that there is no contamination present.
  - Check for an open or short circuit.
  - Replace the Exit Sensor (REP 1.19), PL 4.1.

In Diagnostics, go to **[102-Sensor, Registration]** to block and clear the Registration Sensor. **The signal changes.**

- Y N**
- Check that there is no contamination present.
  - Check for an open or short circuit.
  - Replace the Feed Sensor PWB (REP 1.14), PL 4.4.

Inspect the Exit Roller and Drives for wear or damage. Replace if needed. PL 4.4.

## 08-700 Output Tray Full Fault

The Output Tray Full Sensor has detected that the Output Tray is full.

**BSD-Reference:** 10.2 Print Exit

### Initial Actions

Remove sheets from the Output Tray. (Maximum capacity is 250 sheets/ standard paper 8.5 x 11 in./ 80g/m2.)

### Procedure

Enter Diagnostic (EDC) Mode. Select: **[DC330 Test Routines, 101-Clutch, Out Bin Full]** to block and clear the Out Bin Full Sensor. **The signal changes.**

- |   |  |
|---|--|
| Y | N  |
|   |  |
|   | • Check that the sensor connector is firmly seated.        |
|   | • Check that there is no contamination present.            |
|   | • Check for an open or short circuit.                      |
|   | • Replace the Output Tray Full Sensor, (REP 1.20), PL 4.3. |

Check actuator for binding. If the problem is intermittent, replace the Out Bin Full Sensor Actuator, (REP 1.20), PL 4.3.

## 08-600 Paper Jam in Duplex Area Fault

The machine has detected a paper jam in the Duplex Area.

**BSD-Reference:** 10.2 Print Exit

### Initial Actions

Remove jammed sheets from duplex area. Refer to Section 7: Troubleshooting, in the Xerox® Phaser® 3052/3260 User Guide for detailed instructions on clearing paper jams.

Ensure that the paper guide and machine settings are correct for the paper that is loaded in the tray.

### Procedure

Check the Exit Sensor Actuator. **The actuator moves freely.**

- |   |   |
|---|---|
| Y | N   |
|   |   |
|   | Replace the Exit Sensor Actuator, (REP 1.19), PL 4.1. |

Enter Diagnostics (EDC) Mode. Select: **[DC330 Test Routines, 102-Sensor, Exit Sens]** to block and clear the Exit Sensor. **The sensor is OK.**

- |   |  |
|---|--|
| Y | N  |
|   |  |
|   | • Check that the sensor connector is firmly seated |
|   | • Check that there is no contamination present.    |
|   | • Check for an open or short circuit.              |
|   | • Replace the Exit Sensor (REP 1.19), PL 4.1.      |

Check the following parts for wear or damage and replace if needed:

- Duplex Paper Guide (REP 1.18), PL 4.2
- Duplex Gate PL 4.2
- Duplex Gate Spring PL 4.2
- Duplex Gate Mounting PL 4.2
- Paper Guide on Rear Cover [PL 1.2]

Make certain that the Duplex Gate is seated correctly and moves freely without binding.PL



## 09-100 Toner Cartridge Near End of Life Fault

The Toner Cartridge life is less than 10%.

**BSD-Reference:** None

### Procedure

1. Check the remaining life of the Toner Cartridge by using one of the methods listed below:
  - Print a Supplies Information Report. [\[GP 2\]](#)
  - Open Easy Printer Manager, check Toner Life.
  - Open the CWIS application. Select; **[Status, Supplies, Print Cartridge]**.

**NOTE:** *The workstation and printer machine must be networked to use the CWIS application.*

2. Check the remaining life of the Toner Cartridge.
3. If the Toner Cartridge has reached end of life, switch Off the power and replace the Toner Cartridge.

## 09-300 Imaging Unit Near End of Life Fault

The Imaging Unit life is less than 10%.

**BSD-Reference:** None

### Procedure

1. Check the remaining life of the Imaging Unit by using one of the methods listed below:
  - Print a Supplies Information Report. [\[GP 2\]](#)
  - Open Easy Printer Manager, select **[Machine Settings, ]**
  - Open the CWIS application. Select; **[Status, Supplies, Black Imaging Unit]**.

**NOTE:** *The workstation and printer machine must be networked to use the CWIS application.*

2. Check the remaining life of the Imaging Unit.
3. If the Imaging Unit has reached end of life, switch Off the power and replace the Imaging Unit.

## 09-350 Toner Cartridge End of Life Fault

The Toner Cartridge has reached end of life.

**BSD-Reference:** None

### Procedure

1. Check the remaining life of the Toner Cartridge by using one of the methods listed below:
  - Print a Supplies Information Report. [\[GP 2\]](#)
  - Open Easy Printer Manager, check Toner Life.
  - Open the CWIS application. Select; **[Status, Supplies, Print Cartridge]**.

**NOTE:** The workstation and printer machine must be networked to use the CWIS application.

2. Check the remaining life of the Toner Cartridge.
3. If the Toner Cartridge has reached end of life, switch Off the power and replace the Toner Cartridge.

## 09-400 Imaging Unit End of Life Fault

The Imaging Unit has reached end of life.

**BSD-Reference:** None

### Procedure

1. Check the remaining life of the Imaging Unit by using one of the methods listed below:
  - Print a Supplies Information Report. [\[GP 2\]](#)
  - Open Easy Printer Manager, select **[Machine Status]**.
  - Open the CWIS application. Select; **[Status, Supplies, Black Imaging Unit]**.

**NOTE:** The workstation and printer machine must be networked to use the CWIS application.

2. Check the remaining life of the Imaging Unit.
3. If the Imaging Unit has reached end of life, switch Off the power and replace the Imaging Unit.

## 09-550 Toner Cartridge Undetected Fault

The Toner Cartridge has not been installed or machine software is unable to detect the Toner Cartridge.

**BSD-Reference:** 9.1 Xerographics

### Initial Actions

Ensure that the Toner Cartridge has been installed and the cover is fully closed and latched.

### Procedure

1. Switch Off the power.
2. Remove the Toner cartridge. Rotate the cartridge five to six completions to distribute the toner evenly.
3. Check the CRUM contact area for contamination and clean if necessary.
4. Reinstall the Toner Cartridge.
5. Check the connections on the HVPS for contamination. Clean as necessary.
6. If the problem continues, install a new Toner Cartridge.

## 09-800 Incompatible Toner Cartridge Fault

The Toner Cartridge is not compatible with the printer.

**BSD-Reference:** None

### Procedure

1. Print a Supplies Information Report, [\[GP 2\]](#).
2. Check the Toner Cartridge information. Replace the Toner Cartridge if is not a genuine Xerox® cartridge.

## 09-900 Imaging Unit Undetected Fault

The Imaging Unit has not been installed or machine software is unable to detect the Imaging Unit.

**BSD-Reference:** 9.1 Xerographics

### Initial Actions

- Ensure that a genuine Xerox Imaging Unit has been installed.
- Switch Off the power then switch On the power.

### Procedure

#### WARNING

Do not perform repair activities with the power on or electrical power supplied to the machine. The machine could activate and cause serious personal injury when the power is on or electrical power is supplied.

**DANGER:** Ne pas effectuer de dépannage avec le contact principal activé ou avec l'alimentation électrique appliquée à la machine: celle-ci pourrait démarrer et causer de graves blessures.

**AVVERTENZA:** Non effettuare alcuna riparazione con la macchina accesa o con l'alimentazione elettrica inserita. La macchina potrebbe avviarsi all'improvviso e causare gravi ferite.

**VORSICHT:** Es dürfen keine Reparaturarbeiten durchgeführt werden, solange das Gerät eingeschalten oder mit der Stromquelle verbunden ist. Das Gerät kann u.U in den Aktiv-Zustand übergehen und somit erhebliche körperliche Schäden verursachen.

**AVISO:** No realice reparaciones con la máquina encendida o conectada a la corriente. La máquina podría activarse y ocasionar daños personales graves.

1. Switch Off the power.
2. Remove the Imaging Unit.
3. Check the CRUM contact area for contamination and clean if necessary.
4. Reinstall the Imaging Unit
5. Check the contacts on the HVPS.
6. If the problem continues, install a new Imaging Unit.

## 10-100 Fuser Temperature (Open) Fault

The temperature of the Fuser is outside of the normal operating range of 383°F ± 5°F (195°C ± 5°C.)

**BSD-Reference:** 10.1 Fuser

### Initial Actions

Switch Off the power then switch On the power.

### Procedure

#### WARNING

Do not handle the fuser components until they have cooled. Some fuser components operate at hot temperatures and can produce serious personal injury if touched.

**DANGER:** Ne pas manipuler les éléments du four avant de les laisser refroidir. Certains éléments du four fonctionnent à des températures très élevées et peuvent causer de graves blessures s'ils sont touchés.

**AVVERTENZA:** Non maneggiare i componenti del fusore finché non sono raffreddati. Alcuni di questi componenti funzionano ad alte temperature e possono provocare gravi ferite se vengono toccati.

**VORSICHT:** Die Fixieranlage sollte erst gehandhabt werden, wenn diese genügend abgekühlt ist. Einige Teile der Fixieranlage erzeugen übermäßige Hitze und führen bei der Berührung zu schweren Verbrennungen.

**AVISO:** No manipule los componentes del fusor antes de que se enfríen. Algunos de los componentes del fusor funcionan a altas temperaturas y pueden ocasionar daños personales graves si se los toca.

Power Off the machine and check that the Fuser connection is fully seated, [REP 1.17](#). **The Fuser connections are OK.**

Y N

- Check the Fuser connections for contamination and clean as required.
- Firmly reconnect the Fuser Assembly. Switch the power ON,

Check for +3.3 VDC to the Thermistor on Main PWB. **The voltage is present.**

Y N

- Check the wire harness for open or short circuits.
- Replace the Main PWB ([REP 1.8](#)), [PL 1.1](#).

Check the voltage to the Over Heat Thermostat. **The voltage is present.**

Y N

- Check for AC line voltage to the LVPS PWB [PL 4.1](#).
- Check the Over Heat thermostat for contamination.
- Check the wire harness from the LVPS PWB for open or short circuits.
- Replace the LVPS PWB ([REP 1.6](#)), [PL 4.1](#).

- Check the circuits and connectors for the Fuser Module.
- Check the Heat Lamp for an open circuit.
- Repair or replace the Fuser Assembly as required ([REP 1.17](#)), [PL 5.1](#).

## 10-200/ 300 Fuser Under/ Over Temperature Fault

The temperature of the Fuser is outside of the normal operating range of 383°F ± 5°F (195°C ± 5°C.)

**BSD-Reference:** 10.1 Fuser

### Initial Actions

Switch Off the power. Remove and reinstall the Fuser Assembly. Switch On the power.

### Procedure

#### WARNING

**Do not handle the fuser components until they have cooled. Some fuser components operate at hot temperatures and can produce serious personal injury if touched.**

**DANGER: Ne pas manipuler les éléments du four avant de les laisser refroidir. Certains éléments du four fonctionnent à des températures très élevées et peuvent causer de graves blessures s'ils sont touchés.**

**AVVERTENZA: Non maneggiare i componenti del fusore finché non sono raffreddati. Alcuni di questi componenti funzionano ad alte temperature e possono provocare gravi ferite se vengono toccati.**

**VORSICHT: Die Fixieranlage sollte erst gehandhabt werden, wenn diese genügend abgekühlt ist. Einige Teile der Fixieranlage erzeugen übermäßige Hitze und führen bei der Berührung zu schweren Verbrennungen.**

**AVISO: No manipule los componentes del fusor antes de que se enfrien. Algunos de los componentes del fusor funcionan a altas temperaturas y pueden ocasionar daños personales graves si se los toca.**

Enter Diagnostic (EDC) Mode. Select: **[DC330 Test Routines, 109 Fuser Heat, Temp A]** to obtain a temperature reading from the Fuser. **The Fuser temperature is within normal operating range.**

**Y N**  
| Replace the Fuser Assembly (REP 1.17), PL 5.1.

If problem is intermittent, check the circuit of the Fuser Assembly for one of the following:

- All connectors are securely connected and no contamination is present.
- Short circuit or damaged wire. Repair as necessary.

## 17-100 IP Conflict Error Fault

The IP address conflicts with that of another system causing a machine communication error.

**BSD-Reference:** None

### Procedure

Use Xerox Easy Print Manger to obtain a new IP address.

From the menu, select: **[Advanced Settings, Machine Settings, Network Settings, Assign IP address]**.

## 17-310 Communication Error (Main PWB to Wireless PWB) Fault

The machine software has detected a communication error between the Main PWB and the Wireless PWB.

**BSD-Reference:** 3.1A Communications

### Initial Actions

- Switch Off the power then switch On the power.
- Check machine network and data configuration settings.

### Procedure

1. Ensure that the connectors are fully seated between the Main PWB and the Wireless PWB, [REP 1.21](#).
2. If the problem persists, replace parts in the following order:
  - Flat Cable [PL 4.1](#)
  - Wireless PWB [[REP 1.12](#)] , [PL 3.1](#)
  - Main PWB [[REP 1.8](#)] , [PL 1.1](#)

## 17-700 / 710 BOOTP Error Fault

The machine displays the error message "DHCP, or BOOTP, causing a machine communication error.

**BSD-Reference:** 3.1A, 3.1B Communications

### Procedure

1. Switch Off the power then switch On the power.
2. Check BOOTP and network configuration.

## 17-800 / 810 DHCP Error Fault

The machine displays the error message "DHCP, or BOOTP, causing a machine communication error.

**BSD-Reference:** 3.1A, 3.1B Communication

### Procedure

1. Switch Off the power then switch On the power.
2. Check DHCP and network configuration.

## 17-900 802.1X Network Authentication Error Fault

The the 802.1X network authentication failed.

**BSD-Reference:** None

### Procedure

Ensure that the 802.1X EAP Type, User name, and Password, for the Machine, Authentication Switch and Authentication Server match.

## 17-910 Firmware Upgrade Fault

The firmware upgrade aborted due to an invalid file.

**BSD-Reference:** None

### Initial Actions

1. Check the USB connection.
2. Verify that the correct firmware file is being used.

### Procedure

Cycle the machine power and repeat upgrade procedure [GP 6](#).



---

## 3 Image Quality

Image Quality Overview .....	3-3
IQ1 Vertical Black Line and Band RAP .....	3-4
IQ2 Vertical White Line and Band RAP .....	3-4
IQ3 Horizontal Black Bands RAP .....	3-5
IQ4 Spots RAP .....	3-5
IQ5 Low Image Density RAP .....	3-6
IQ6 Black or Dark Image RAP .....	3-7
IQ7 Uneven Density RAP .....	3-8
IQ8 Background RAP .....	3-9
IQ9 Residual Image (Ghosting) RAP .....	3-9
IQ10 Side 2 Staining .....	3-10
IQ11 Blank Page RAP .....	3-11
IQ12 Partial Image Deletions RAP .....	3-12



## Image Quality Overview

Image quality defects can be attributed to printer components, consumables, media, internal software, external software applications, and environmental conditions. To successfully troubleshoot print-quality problems, eliminate as many variables as possible.

If the print-quality defect is still present after printing on approved media from an unopened ream of paper, investigate software applications and environmental conditions. Check the temperature and humidity under which the printer is operating. Compare this to the Environmental Specifications listed in Section 6.

When analyzing a imaging defect, determine if the defect is repeating or random. Check the Supplies Information Report for end of life conditions. Inspect the visible surfaces of all rollers for obvious defects. If a cursory inspection does not reveal any obvious defects, continue troubleshooting the defect.

### WARNING

**Do not perform repair activities with the power on or electrical power supplied to the machine. Some machine components contain dangerous electrical voltages that can result in electrical shock and possible serious injury.**

**DANGER: Ne pas effectuer de dépannage avec le contact principal activé ou avec l'alimentation électrique appliquée à la machine. Certains éléments de la machine comportent des tensions électriques dangereuses qui peuvent causer un choc électrique et de graves blessures.**

**AVVERTENZA: Non effettuare alcuna riparazione con l'alimentazione elettrica inserita. Alcuni componenti contengono corrente ad alta tensione che può provocare forti scosse e gravi ferite.**

**VORSICHT: Es dürfen erst Reparaturarbeiten durchgeführt werden, wenn das Gerät ausgeschaltet ist oder der Netzstecker nicht mehr mit der Stromquelle verbunden ist. Einige Komponenten des Gerätes sind stromführend und können daher zu ernsthaften Verletzungen oder Stromschlägen führen.**

**AVISO: No realice reparaciones con la máquina encendida o conectada a la corriente. Algunos componentes de la máquina contienen voltajes eléctricos peligrosos que pueden producir una descarga eléctrica y causar daños graves.**

### Defects Associated with Specific Components

To aid with diagnosis, the list below outlines image defects associated with specific components.

#### Laser Scanner Unit (LSU)

- Black Print
- Vertical White Lines

#### Transfer Roller:

- Uneven Density
- Background contamination
- Ghosting
- Vertical white lines
- Vertical black line or band
- Stains on the page back

#### Fuser:

- Ghosting
- Stains on the page back or front
- Poor image adhesion

#### Print Cartridge:

- Uneven density
- Background contamination
- Spots, smudges, or smears
- Ghosting
- Vertical white lines
- Vertical black line or band
- Stains on the page front
- Blank prints
- Black prints
- Horizontal Black lines or bands

After determining the defect type and possible source, match the defect with those listed in [Table 1](#). Go to the RAP listed to correct the defect.

## Image Defect Definitions

[Table 1](#) lists image defect definitions and the RAP used to correct the problem.

Table 1 Image Defect Definitions

Defect	Definition	Go To
Vertical Black Line and Band	Vertical black lines or bands occur in the printed image.	IQ1
Vertical White Line and Band	Vertical white lines or bands occur in the printed image.	IQ2
Horizontal Black Band	Periodic dark or blurry horizontal bands in the printed image.	IQ3
Spots	Random or periodic dark areas in the low density areas of a print, or voids in the dark areas of a print.	IQ4
Low Image Density	Printed image is light with no ghosting.	IQ5
Black or Dark Image	Printed image is totally dark or black.	IQ6
Uneven Density	Print density is uneven between the left and right portion of the printed image.	IQ7
Background	Uniform toner contamination in most or all non-image areas.	IQ8
Residual Image (Ghosting)	The image from a previous print appears on the current print.	IQ9
Blank Page	The entire image area is blank.	IQ10
Partial Image Deletions	Areas of the printed image are light or missing entirely on limited areas of the paper.	IQ11

## IQ1 Vertical Black Line and Band RAP

Thin black vertical lines or black vertical bands occur in the printed image.

### Procedure

Switch Off the power.

Check the Transfer Roller, [PL 3.1](#) for wear or damage. **The Transfer Roller is OK.**

Y N

Replace the Transfer Roller;([REP 1.13](#)), [PL 3.1](#).

Switch On the power and make a test print. If problem persists, replace the Drum Cartridge. (PL-XX). Refer to the Xerox® Phaser® 3020 User Guide, Section 6 Maintenance, General Care, for detailed instructions on how to replace the Drum Cartridge.



0300101bat

Figure 1 Black lines and bands

## IQ2 Vertical White Line and Band RAP

Thin white vertical lines or white vertical bands occur in the printed image.

### Initial Actions

Clean the surface of the LSU window with a clean cotton swab and recommended cleaner (IPA).

### Procedure

From the Control Panel, check the life of the Print Cartridge. **The Print Cartridge has reached end of life.**

Y N

Switch Off the power. Replace the Print Cartridge. Refer to the Xerox® Phaser® 3020 User Guide, Section 6 Maintenance, General Care, for detailed instructions on how to replace the Print Cartridge.

Check the space between the LSU and Imaging Unit and remove any debris or blockage. **The defect is gone.**

Y N

Replace the Fuser Module; ([REP 1.14](#)), [PL 3.2](#).

Switch on the power. Perform SCP 04, Final Actions.



0300102bat

Figure 1 White lines and bands

### IQ3 Horizontal Black Bands RAP

Periodic dark or blurry horizontal stripes in the printed image (Figure 1).

#### Procedure

- Switch Off the power.
- Check high voltage contacts for contamination or damage.
- Switch On the power and make a test print.

The defect is still present.

Y N

Go to Call Closeout.

- Replace the Print Cartridge.
- Refer to the Xerox® Phaser® 3020 User Guide, Section 6 Maintenance, General Care, for detailed instructions on how to replace the Print Cartridges.



0300103bat

Figure 1 Horizontal black bands

### IQ4 Spots RAP

Random or periodic dark areas in the low density areas of a print, or voids in the dark areas of a print (Figure 1).

#### Initial Actions

Ensure that the Imaging Unit is firmly seated.

#### Procedure

Check the Transfer Roller for wear, damage and remaining life. **The Transfer Roller is OK.**

Y N

Replace the Transfer Roller; (REP 1.13), PL 3.1.

Clean the voltage terminals for the Print Cartridges:

Switch on the power and make a test print. **The test print looks OK.**

Y N

Replace the Print Cartridge.

Refer to the Xerox® Phaser® 3020 User Guide, Section 6 Maintenance, General Care, for detailed instructions on how to replace the Print Cartridges.

If problem persists, replace the Fuser Module; (REP 1.14), PL 3.2.



0300104bat

Figure 1 Black spots

## IQ5 Low Image Density RAP

The printed image is light, with no ghosting (Figure 1).

### Initial Actions

Remove Print Cartridge. Rotate the cartridge 5-6 full rotations to redistribute the toner. Make a test print.

Check the life of the Print Cartridge, refer to **GP 2** Machine Status and Reports. Replace the Print Cartridge if it has reached end of life.

If the problems continue, follow the procedure.

### Procedure

- Switch off the power.
- Clean the contacts on the Print Cartridge and the LVPS / HVPS PWB.
- Switch on the power and make a test print.

#### The problem continues.

**Y N**  
| Go to SCP 04 Final Actions.

Replace the LVPS / HVPS PWB; **PL 3.2, (REP 1.6)**.



Figure 1 Light Image

0300105bat

## IQ6 Black or Dark Image RAP

The printed image is totally dark or black (Figure 1).

### Procedure

#### WARNING

**Do not perform repair activities with the power on or electrical power supplied to the machine. Some machine components contain dangerous electrical voltages that can result in electrical shock and possible serious injury.**

**DANGER: Ne pas effectuer de dépannage avec le contact principal activé ou avec l'alimentation électrique appliquée à la machine. Certains éléments de la machine comportent des tensions électriques dangereuses qui peuvent causer un choc électrique et de graves blessures.**

**AVVERTENZA: Non effettuare alcuna riparazione con l'alimentazione elettrica inserita. Alcuni componenti contengono corrente ad alta tensione che può provocare forti scosse e gravi ferite.**

**VORSICHT: Es dürfen erst Reparaturarbeiten durchgeführt werden, wenn das Gerät ausgeschaltet ist oder der Netzstecker nicht mehr mit der Stromquelle verbunden ist. Einige Komponenten des Gerätes sind stromführend und können daher zu ernsthaften Verletzungen oder Stromschlägen führen.**

**AVISO: No realice reparaciones con la máquina encendida o conectada a la corriente. Algunos componentes de la máquina contienen voltajes eléctricos peligrosos que pueden producir una descarga eléctrica y causar daños graves.**

- Switch Off the power.
- Clean the contacts on the Print Cartridge and the LVPS / HVPS PWB.
- Switch on the power and make a test print.

#### The problem continues.

**Y N**  
| Go to Call Closeout.

- If the image is Black, replace the LVPS / HVPS PWB; **PL 3.1 (REP 1.5)**.
- The Charge Roller is likely defective, replace the Print Cartridge.  
Refer to the Xerox® Phaser® 3020 User Guide, Section 6 Maintenance, General Care, for detailed instructions on how to replace the Print Cartridges.



Figure 1 Dark or Black Image

0300106bat

## IQ7 Uneven Density RAP

Print density is uneven between the left and right portion of the printed image (Figure 1).

### Initial Actions

- Ensure that the printer is level.
- Remove the Print Cartridge. Rotate the Print Cartridge 5-6 full rotations to redistribute the toner.
- Check Supplies Life. Refer to [GP 2 Machine Status and Reports](#).
  - Replace any components that have reached end of life.

### Procedure

#### WARNING

**Do not perform repair activities with the power on or electrical power supplied to the machine. Some machine components contain dangerous electrical voltages that can result in electrical shock and possible serious injury.**

**DANGER: Ne pas effectuer de dépannage avec le contact principal activé ou avec l'alimentation électrique appliquée à la machine. Certains éléments de la machine comportent des tensions électriques dangereuses qui peuvent causer un choc électrique et de graves blessures.**

**AVVERTENZA: Non effettuare alcuna riparazione con l'alimentazione elettrica inserita. Alcuni componenti contengono corrente ad alta tensione che può provocare forti scosse e gravi ferite.**

**VORSICHT: Es dürfen erst Reparaturarbeiten durchgeführt werden, wenn das Gerät ausgeschaltet ist oder der Netzstecker nicht mehr mit der Stromquelle verbunden ist. Einige Komponenten des Gerätes sind stromführend und können daher zu ernsthaften Verletzungen oder Stromschlägen führen.**

**AVISO: No realice reparaciones con la máquina encendida o conectada a la corriente. Algunos componentes de la máquina contienen voltajes eléctricos peligrosos que pueden producir una descarga eléctrica y causar daños graves.**

Switch Off the Power. Check the contacts on the Print Cartridge. **The contacts are OK.**

**Y N**

Replace the Print Cartridge.

Refer to the Xerox® Phaser® 3020 User Guide, Section 6 Maintenance, General Care, for detailed instructions on how to replace the Print Cartridges.

Check the Transfer Roller for wear or damage. **The Transfer Roller is OK.**

**Y N**

Replace the Transfer Roller; ([REP 1.13](#)), [PL 3.1](#).

If problem persists, replace the LVPS / HVPS PWB; ([REP 1.5](#)), [PL 3.1](#).



Figure 1 Uneven Density

0300107bat

## IQ8 Background RAP

Uniform toner contamination appears in most or all non-image areas of the printed sheet (Figure 1).

### Initial Actions

- Check that media type settings are correct.
- Check that the paper meets specifications. Refer to Section 6 for product specifications.
- Check the supplies life of the Print Cartridge, refer to GP 2 Machine Status and Reports. Replace the Print Cartridge if it has reached end of life.

### Procedure

- Switch off the power.
- Clean the contacts on the Print Cartridge and the LVPS / HVPS PWB.
- Switch on the power and make a test print.

The test print looks OK.

Y N

Replace the LVPS / HVPS PWB; (REP 1.5), PL 3.1.

Go to SCP 04 Final Actions.



0300108bat

Figure 1 Background



## IQ9 Residual Image (Ghosting) RAP

The image from a previous print appears on the current print (Figure 1).

### Procedure

Switch Off the Power.

Check the Transfer Roller for the following:

- Wear or damage.
- The left and right tension springs for damage.
- Be sure all parts are installed correctly.

**The Transfer Roller is OK.**

**Y N**

Replace the Transfer Roller or parts as needed; (REP 1.13), PL 3.1.

If problem persists, Replace components in the following order:

- Print Cartridge, refer to the Xerox® Phaser® 3020 User Guide, Section 6 Maintenance, General Care, for detailed instructions on how to replace the Print Cartridges.
- Fuser; (REP 1.14), PL 3.2.
- LVPS / HVPS PWB; (REP 1.5), PL 3.1.



Figure 1 Ghost Image

0300109bat

## IQ10 Blank Page RAP

The entire image area is blank (Figure 1).

### Initial Actions

Replace any components at end of life.

### Procedure

- Switch Off the power.
- Check the space between the LSU and the Print Cartridge for a blockage, remove any debris or blockage.
- Clean the contacts on the Print Cartridge and the LVPS / HVPS PWB.
- Switch on the power and make a test print.

**The problem continues.**

**Y N**

Go to Call Closeout.

Replace the Print Cartridge, refer to the Xerox® Phaser® 3020 User Guide, Section 6 Maintenance, General Care, for detailed instructions on how to replace the Print Cartridges. **The problem continues.**

**Y N**

Go to Call Closeout.

Check circuit between the Main PWB and the LVPS / HVPS PWB, BSD 1.1. **The circuit is OK.**

**Y N**

Replace any defective components:

- Main PWB to LVPS / HVPS PWB Wire Harness.
- Main PWB; (REP 1.6), PL 1.1.
- LVPS / HVPS PWB; (REP 1.5), PL 3.1.

Replace the LSU; (REP 1.10), PL 3.6.

## IQ11 Partial Image Deletions RAP

Areas of the printed image are light or missing entirely on limited areas of the paper (Figure 1).

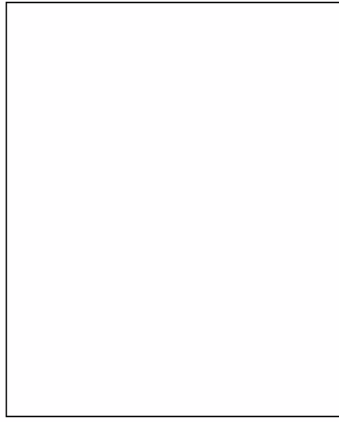

Figure 1 Blank Image

0300111bat

### Initial Actions

Be sure the printer is installed on a level surface.

### Procedure

Procedure

- Switch Off the Power.
- Remove the Print Cartridge.
- Rotate the Print Cartridge side to side for 5 to 6 full rotations to redistribute the toner.
- Reinstall the Print Cartridge and print 10 test copies.

#### The problem continues.

**Y N**

Go to SCP 04 Final Actions.

Switch Off the Power.

Check the Transfer Roller for the following:

- Wear or damage.
- The left and right tension springs for damage.
- Be sure all parts are installed correctly.

#### The Transfer Roller is OK.

**Y N**

Replace the Transfer Roller or parts as needed; (REP 1.13), PL 3.1.

Check the supplies life of the Print Cartridge, refer to GP 2 Machine Status and Reports. Replace the Print Cartridge if it has reached end of life.



0300112bat

**Figure 1 Image Deletions**



REP 1.1 Front Cover .....	4-3
REP 1.2 Left and Right Side Covers .....	4-5
REP 1.3 Top Cover .....	4-6
REP 1.4 Rear Cover .....	4-7
REP 1.5 Control Panel PWB .....	4-8
REP 1.6 LVPS (Low Voltage Power Supply) .....	4-9
REP 1.7 HVPS (High Voltage Power Supply) .....	4-10
REP 1.8 Main PWB .....	4-11
REP 1.9 Drive Motor .....	4-12
REP 1.10 Main Drive Unit .....	4-18
REP 1.11 LSU and Cables .....	4-19
REP 1.12 Retard Roll .....	4-20
REP 1.13 Feed and Registration Clutches / Paper Feed PWB .....	4-22
REP 1.14 Feed and Registration Sensors PWB and Actuators .....	4-22
REP 1.15 Feed and Forward Roll Assembly .....	4-24
REP 1.16 Transfer Roll .....	4-26
REP 1.17 Fuser Module .....	4-27
REP 1.18 Duplex Assembly .....	4-28
REP 1.19 Exit Sensor .....	4-29
REP 1.20 Output Tray Full Sensor .....	4-30
REP 1.21 WNPC (WiFi) PWB .....	4-31
REP 1.22 Exit Roll and Bushings .....	4-32
REP 1.23 Manual Paper Tray .....	4-33
REP 1.24 Feed Idler Gear .....	4-34
REP 1.25 Paper Drive Roll .....	4-35
REP 1.26 Registration Roll .....	4-39
REP 1.27 Manual Feed Cover .....	4-47



## REP 1.1 Front Cover

### Parts List on PL 2.1

#### Removal

1. Switch Off the Printer and disconnect the Power Cord.
2. Remove the Left and Right Side Covers (REP 1.2).
3. Disconnect the wire harness to the Front Cover (Figure 1).



Connector

040402RKB

Figure 1 Front Cover P/J Connector

4. Disconnect the Front Cover Support Arm (Figure 2).

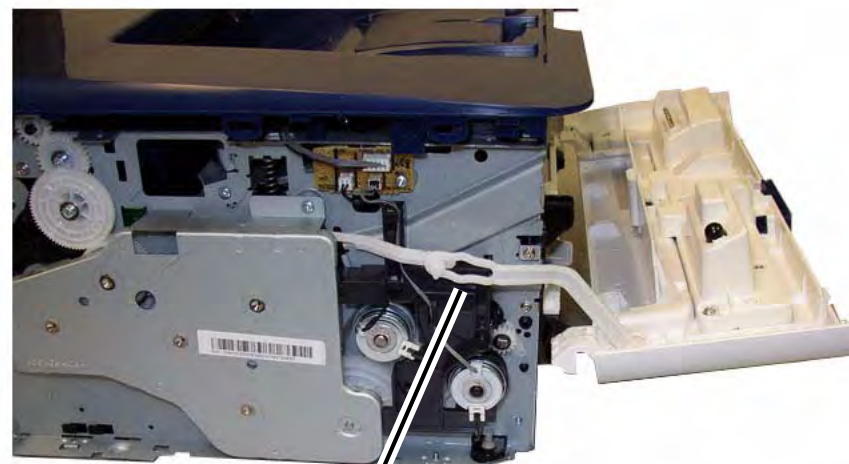

Front Cover Support Arm

040401RKB

Figure 2 Front Cover Support Arm

**NOTE:** A wide blade flat screwdriver can be used to help release the Front Cover Pivot.

5. Release the Front Cover Pivots (2) and remove the cover (Figure 3).

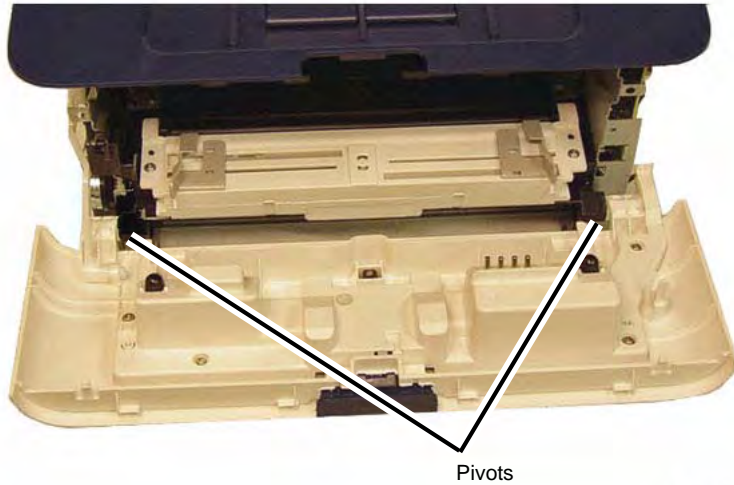

Figure 3 Front Cover Removal

040420RKB



TagMatrix-BAT-KB

Figure 4 Tag Matrix on new Front Cover Assembly

### Replacement

Install the components in the reverse of removal.

6. **IMPORTANT**  
Remove the Tag Matrix from the inside of the manual feed slot.
7. Place the Tag Matrix on the new Front Cover Assembly. Figure 4



## REP 1.2 Left and Right Side Covers

### Parts List on PL 2.1

#### Removal

1. Remove the Paper Cassette from the printer.

**NOTE:** Cover the Drum Cartridge with several sheets of paper to prevent it from being light shocked.

2. Open the Front Cover, remove the Toner Cartridge and the Drum Cartridge (Figure 1).

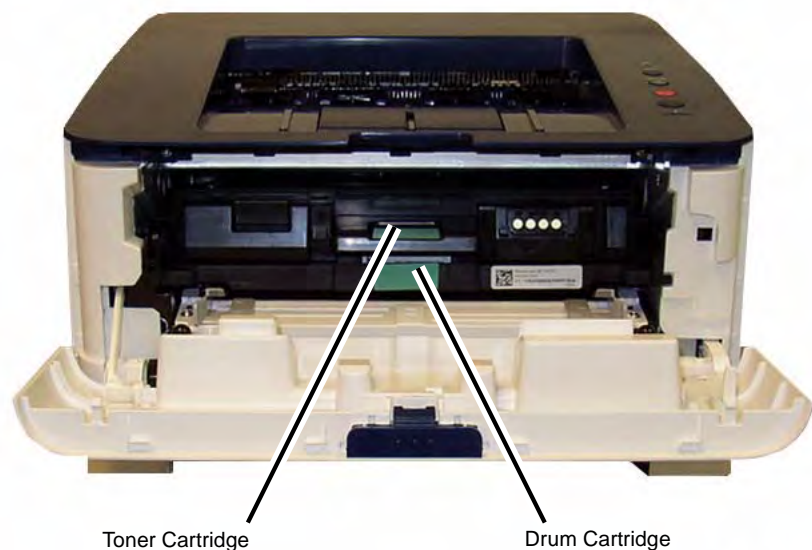

Toner Cartridge

Drum Cartridge

040403RKB

Figure 1 Toner Cartridge and Photoreceptor Handles

3. The side covers are held in place with Plastic Latches, release them carefully to avoid breakage. To release the Latches press the hook end of the latch away from the part (Figure 2).



040401aRBAT

Figure 2 Plastic Latches

4. Remove the Right Side Cover, being careful not to damage the latching hooks.
  - a. Release (pull) the upper front latch hook.
  - b. Release the top latch hooks then the bottom latch hooks.
  - c. Release the front lower latch hook, and remove the cover.
5. Remove the Left Side Cover, being careful not to damage the latching hooks.
  - a. Release (pull) the center front latch hook.
  - b. Release the top latch hooks then the bottom latch hooks.
  - c. Release the rear latch hook, and remove the cover.

#### Replacement

Install the components in the reverse of removal.

## REP 1.3 Top Cover

### Parts List on PL 3.1

#### Removal

1. Switch Off the Printer and disconnect the Power Cord.
2. Remove the following covers:
  - a. Remove the Left and Right Side Covers (REP 1.2).
  - b. Remove the Front Cover (REP 1.1).
  - c. Remove the Rear Cover (REP 1.4).
3. Disconnect the Control Panel connector from the Main PWB (Figure 1).  
For a Phaser 3052 also disconnect the WNPC (WiFi) connector.

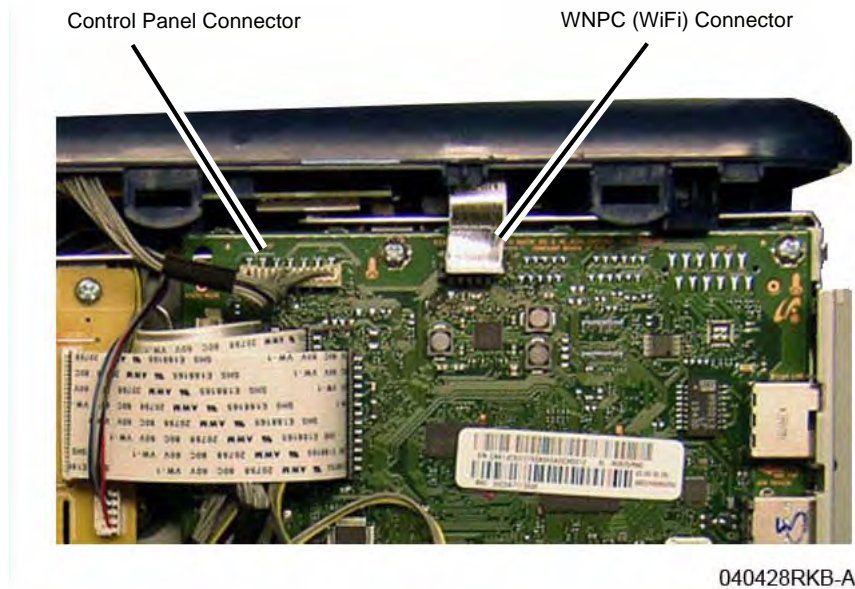
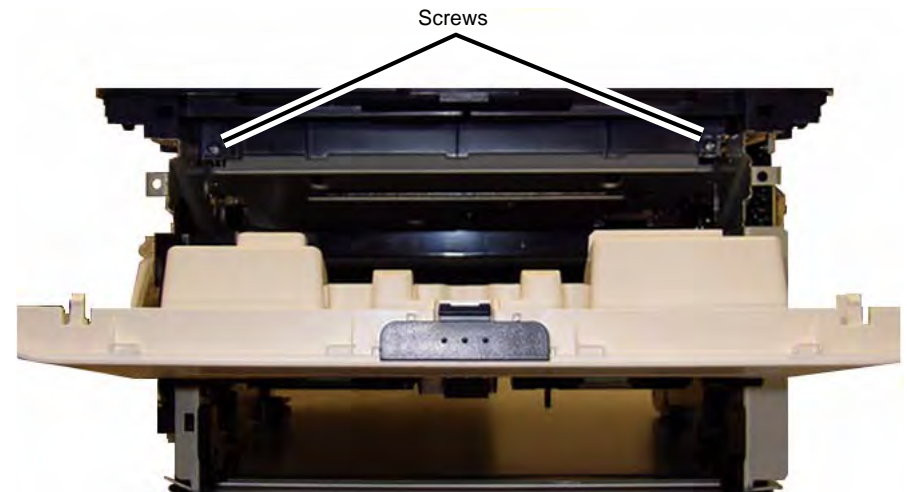

Figure 1 Main PWB Connectors to Disconnect

4. Remove the Top Cover screws (2) at the front of the printer (Figure 2).



040409RKB

Figure 2 Top Cover Screws (Front View)

5. Release the Latch Hooks (2) at the rear of the printer, and remove the Top Cover (Figure 3).

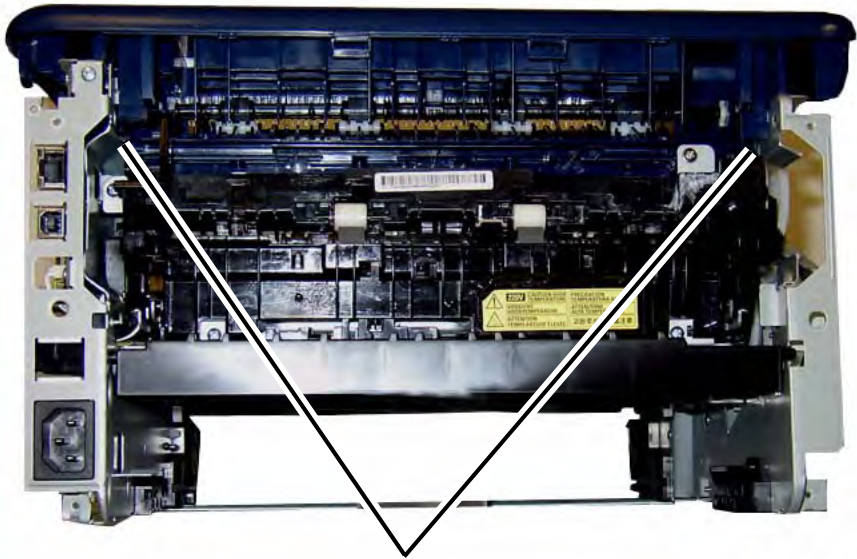

Latch Hooks

040408RKB

Figure 3 Top Cover Latch Hooks

**Replacement**

Install the components in the reverse of removal.

**REP 1.4 Rear Cover**

**Parts List on PL 2.1**

**Removal**

1. Remove the Left and Right Side Covers (REP 1.2).
2. Remove the Rear Cover Screws (4) (Figure 1).

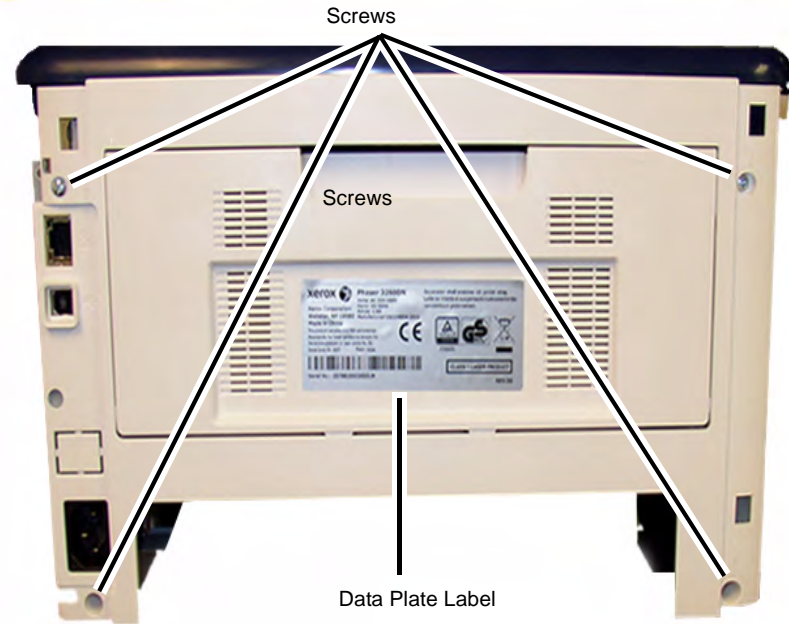

Screws

Screws

Data Plate Label

040406RKB

Figure 1 Rear Cover Screws and Data Plate Label

3. Open the Rear Cover and release the Support Arms on each side of the Rear Cover (Figure 2).

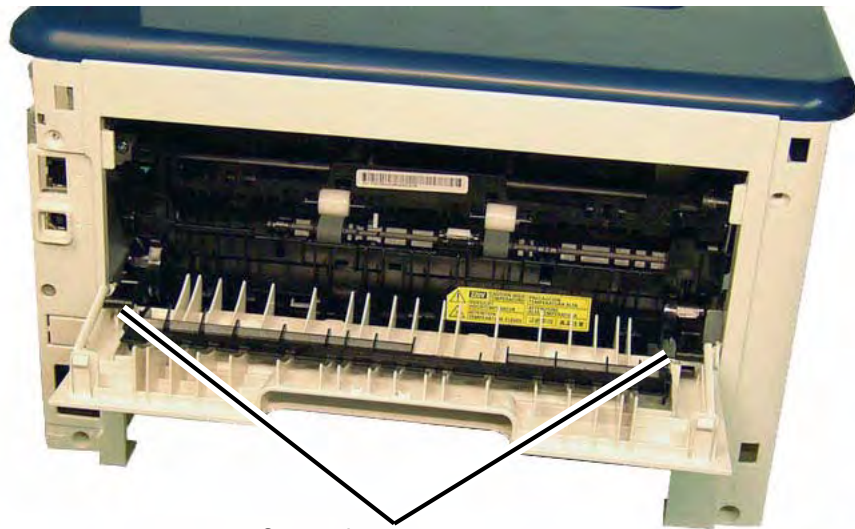

Support Arms

040419RKB

Figure 2 Releasing the Support Arms

4. Push down on the top of the Rear Cover to release the Latch Hooks (3) and remove the cover.

### Replacement

**Important:** If the Rear Cover is being replaced, remove the Data Plate Label from the old Rear Cover and install it onto the new Rear Cover (Figure 1).

Install the components in the reverse of removal.

## REP 1.5 Control Panel PWB

### Parts List on PL 3.1

### Removal

1. Switch Off the Printer and disconnect the Power Cord.
2. Remove the following covers:
  - a. Remove the Left and Right Side Covers (REP 1.2).
  - b. Remove the Front Cover (REP 1.1).
  - c. Remove the Rear Cover (REP 1.4).
  - d. Remove the Top Cover (REP 1.3).
3. Remove the screws (2) and release the latches (4) to remove the Control Panel PWB (Figure 1).

The Figure shows the Phaser 3062 Without the Wireless (WLAN) PWB.

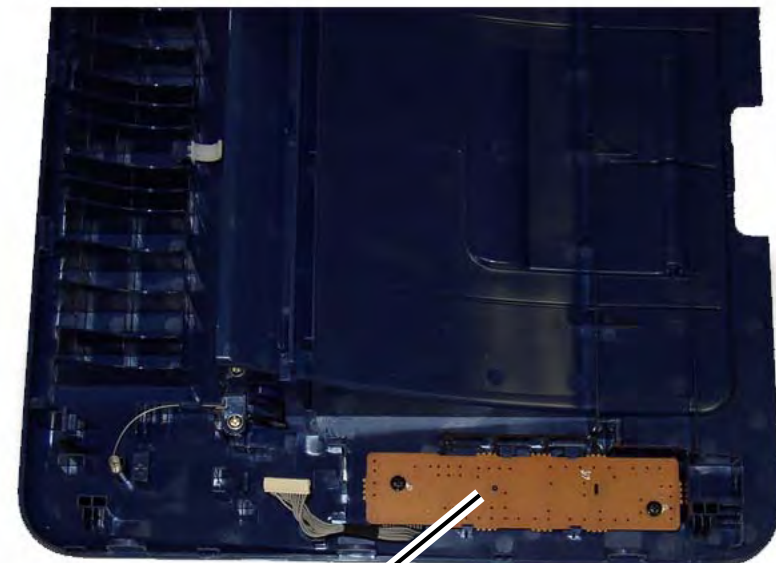

Control Panel PWB

040410RKB

Figure 1 Control Panel PWB (Underside of Top Covers)

### Replacement

Install the components in the reverse of removal.

## REP 1.6 LVPS (Low Voltage Power Supply)

### Parts List on PL 4.1

#### Removal

#### WARNING

Do not perform repair activities with the power on or electrical power supplied to the machine. Some machine components contain dangerous electrical voltages that can result in electrical shock and possible serious injury.

**DANGER:** Ne pas effectuer de dépannage avec le contact principal activé ou avec l'alimentation électrique appliquée à la machine. Certains éléments de la machine comportent des tensions électriques dangereuses qui peuvent causer un choc électrique et de graves blessures.

**AVVERTENZA:** Non effettuare alcuna riparazione con l'alimentazione elettrica inserita. Alcuni componenti contengono corrente ad alta tensione che può provocare forti scosse e gravi ferite.

**VORSICHT:** Es dürfen erst Reparaturarbeiten durchgeführt werden, wenn das Gerät ausgeschaltet ist oder der Netzstecker nicht mehr mit der Stromquelle verbunden ist. Einige Komponenten des Gerätes sind stromführend und können daher zu ernsthaften Verletzungen oder Stromschlägen führen.

**AVISO:** No realice reparaciones con la máquina encendida o conectada a la corriente. Algunos componentes de la máquina contienen voltajes eléctricos peligrosos que pueden producir una descarga eléctrica y causar daños graves.

1. Switch Off the Printer and disconnect the Power Cord.
2. Remove the Right Side Covers (REP 1.2).

3. Remove the LVPS PWB (Figure 1):
  - a. Disconnect the connectors (2)
  - b. Remove the screws (6) and the LVPS PWB.

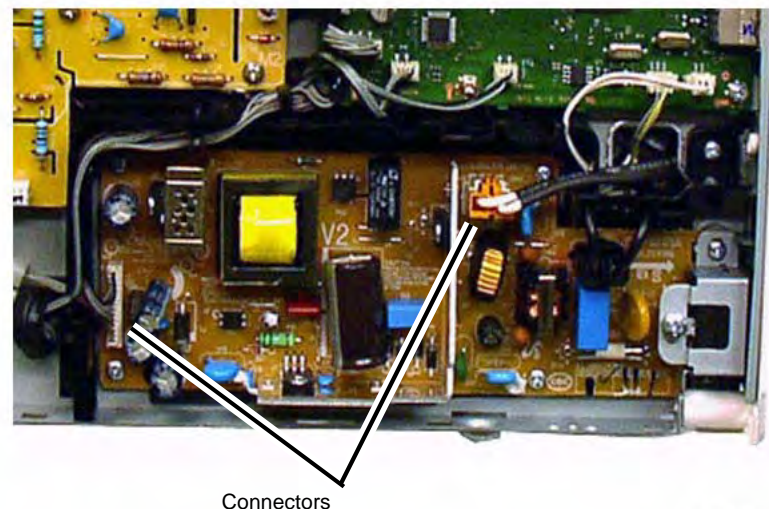

040417aRKB

Figure 1 LVPS PWB

#### Replacement

**NOTE:** Tapered Plastic Screws and Round Machine Screws are used to hold the PWB to the frame. Make sure that the Plastic Screws go into plastic components and Machine Screws go into the metal frame.

Install the components in the reverse of removal.

## REP 1.7 HVPS (High Voltage Power Supply)

### Parts List on PL 4.1

#### Removal

#### WARNING

Do not perform repair activities with the power on or electrical power supplied to the machine. Some machine components contain dangerous electrical voltages that can result in electrical shock and possible serious injury.

**DANGER:** Ne pas effectuer de dépannage avec le contact principal activé ou avec l'alimentation électrique appliquée à la machine. Certains éléments de la machine comportent des tensions électriques dangereuses qui peuvent causer un choc électrique et de graves blessures.

**AVVERTENZA:** Non effettuare alcuna riparazione con l'alimentazione elettrica inserita. Alcuni componenti contengono corrente ad alta tensione che può provocare forti scosse e gravi ferite.

**VORSICHT:** Es dürfen erst Reparaturarbeiten durchgeführt werden, wenn das Gerät ausgeschaltet ist oder der Netzstecker nicht mehr mit der Stromquelle verbunden ist. Einige Komponenten des Gerätes sind stromführend und können daher zu ernsthaften Verletzungen oder Stromschlägen führen.

**AVISO:** No realice reparaciones con la máquina encendida o conectada a la corriente. Algunos componentes de la máquina contienen voltajes eléctricos peligrosos que pueden producir una descarga eléctrica y causar daños graves.

1. Switch Off the Printer and disconnect the Power Cord.
2. Remove the Right Side Cover (REP 1.2).

**NOTE:** When removing the HVPS PWB be careful not to lose the spring loaded contacts between the Print Cartridge and the HVPS PWB.

3. Remove the HVPS PWB. (Figure 1).
  - a. Disconnect all the connectors on the HVPS PWB.
  - b. Remove the screws (6) and the HVPS PWB.

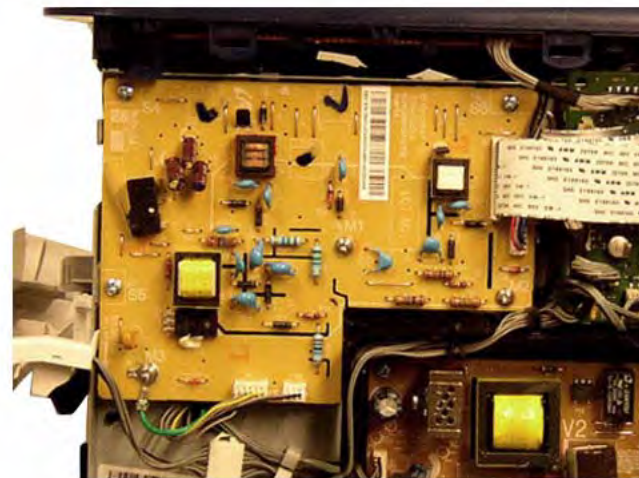

040411RKB

Figure 1 HVPS PWB

#### Replacement

Install the components in the reverse of removal.

## REP 1.8 Main PWB

### Parts List on PL 1.1

#### Removal

#### WARNING

Do not perform repair activities with the power on or electrical power supplied to the machine. Some machine components contain dangerous electrical voltages that can result in electrical shock and possible serious injury.

**DANGER:** Ne pas effectuer de dépannage avec le contact principal activé ou avec l'alimentation électrique appliquée à la machine. Certains éléments de la machine comportent des tensions électriques dangereuses qui peuvent causer un choc électrique et de graves blessures.

**AVVERTENZA:** Non effettuare alcuna riparazione con l'alimentazione elettrica inserita. Alcuni componenti contengono corrente ad alta tensione che può provocare forti scosse e gravi ferite.

**VORSICHT:** Es dürfen erst Reparaturarbeiten durchgeführt werden, wenn das Gerät ausgeschaltet ist oder der Netzstecker nicht mehr mit der Stromquelle verbunden ist. Einige Komponenten des Gerätes sind stromführend und können daher zu ernsthaften Verletzungen oder Stromschlägen führen.

**AVISO:** No realice reparaciones con la máquina encendida o conectada a la corriente. Algunos componentes de la máquina contienen voltajes eléctricos peligrosos que pueden producir una descarga eléctrica y causar daños graves.

1. Record the machine serial number from the Data Plate (located on the rear cover beneath the bar code) or from a Configuration Report printed prior to installing the new PWB. To print a Configuration Report, select from the PWS; [**Easy Print Manager, Machine Setting, Print Information, Configuration**].
2. Switch Off the Printer and disconnect the Power Cord.
3. Remove the Right Side Cover (REP 1.2).
4. Remove the WNPC (WiFi) PWB if installed ([REP 1.21]).

**NOTE:** Mark the location of the Ground Screw, with larger head, so it can be re-installed in the correct location.

5. Remove the Main PWB. (Figure 1).
  - a. Disconnect all connectors on the Main PWB.
  - b. Remove the screws (5) and the Main PWB.

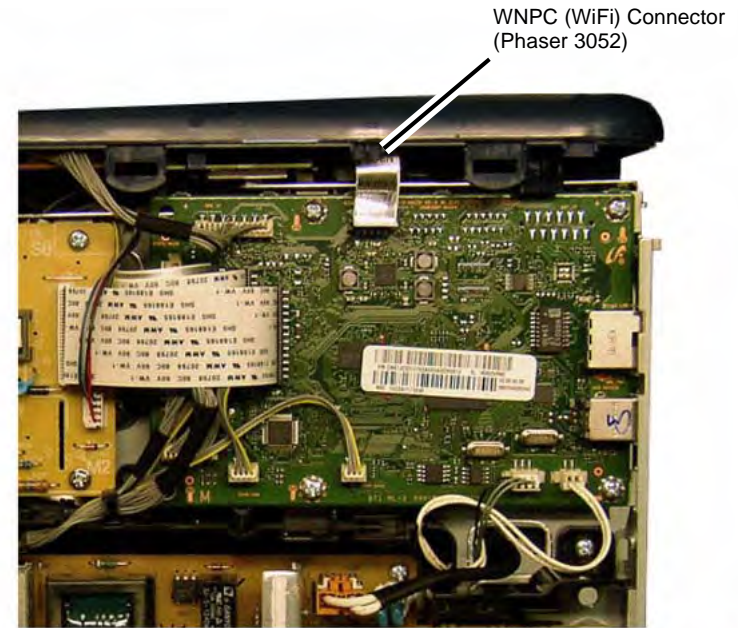

040428RKB-B

Figure 1 Main PWB

#### Replacement

**NOTE:** Tapered Plastic Screws and Round Machine Screws are used to hold the PWB to the frame. Make sure that the Plastic Screws go into plastic components and Machine Screws go into the metal frame.

Install the components in the reverse of removal.

After installing a new Main PWB, the following steps MUST be performed to write the machine serial number to the new Main PWB:

1. Reconnect the Power Cord. Power On the machine.
2. Connect the PWS to the printer via USB connection.
3. Run the USB Serial Number Writing Tool application. (Download the USB Serial Number writing application to the PWS from the GSN website). Ref. GP 8.
  - a. Double-click the executable file and follow the steps listed in the USB Serial application window to write the machine serial number to the new Main PWB. (Figure 2).

**NOTE:** Select the [**Check USB**] button to ensure that there is a good USB connection BEFORE entering the serial number. If the connection is good, "USB Success," will display in the area above the button. If there is an problem with the USB connection, "USB Fail" will display.

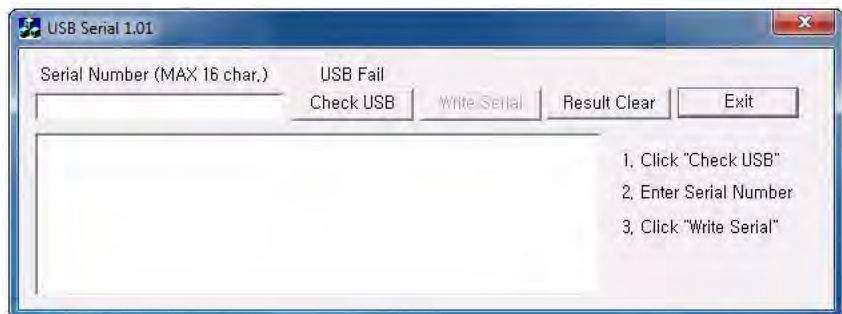

040440RKB

**Figure 2 PWB Serial Number Screen**

- b. After successfully entering the serial number, exit the PWB Serial Number writing application.
4. Print a Configuration Report and check that the original machine serial number is displayed under the "Device Profile" heading.

## REP 1.9 Drive Motor

### Parts List on PL 4.6

#### Removal

1. Switch Off the Printer and disconnect the Power Cord.
2. Remove the following covers:
  - a. Remove the Left and Right Side Covers (REP 1.2).
  - b. Remove the Front Cover (REP 1.1).
  - c. Remove the Rear Cover (REP 1.4).
  - d. Remove the Top Cover (REP 1.3).



3. Remove the Bottom Bar and Assembly (Figure 1).
  - a. Remove the screws (2) and Bottom Bar.
  - b. Press the Green Tabs (2) to unlatch the Duplex Assembly.

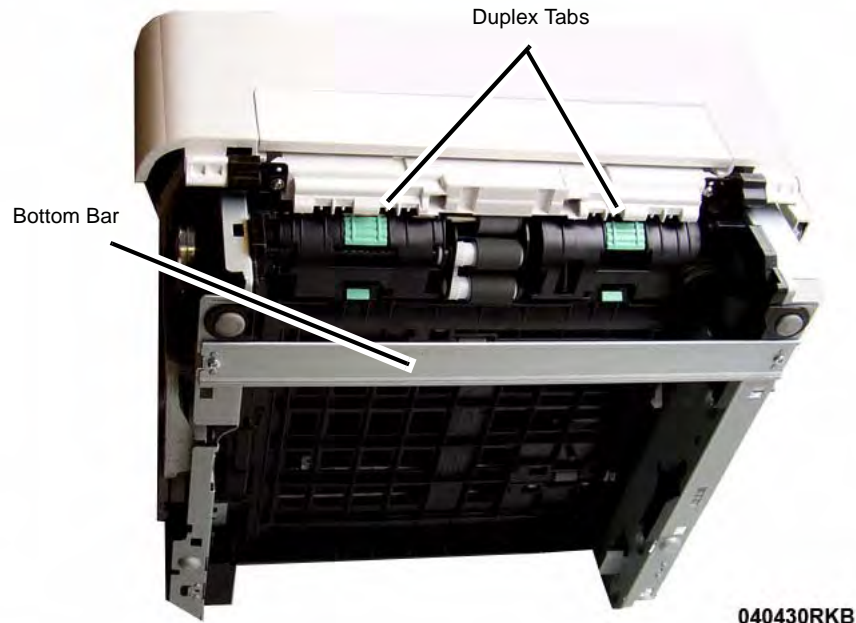

**Figure 1 Bottom Bar and Duplex Assembly (Bottom View)**

040430RKB

4. Remove the Main Drive Unit (5 screws) and move the Fuser Drive Locking Lever to the Unlock position (Right) (Figure 2).

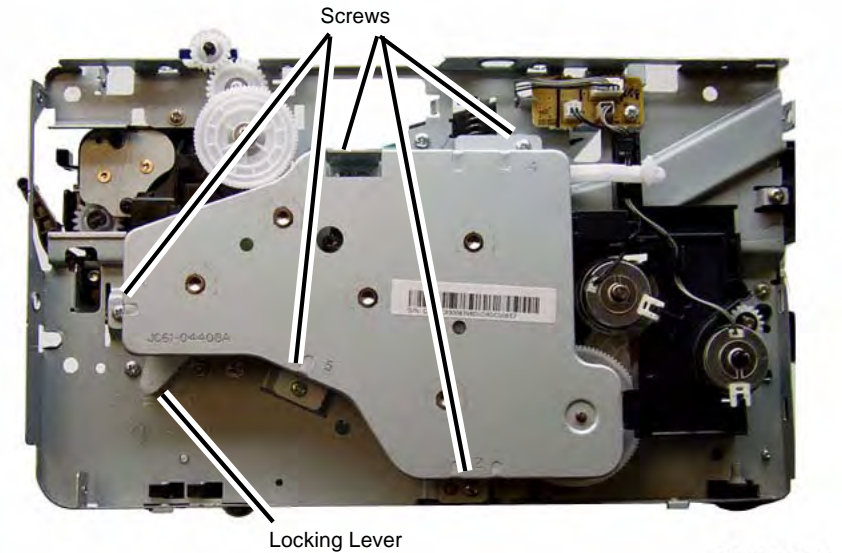

040445RKB

**Figure 2 Main Drive Unit**

5. Perform the Following (Figure 3):
  - a. Disconnect the Feeder PWB Connector (CN3), and remove the PWB (1 screw).
  - b. Remove the Feed and Registration Clutches, remove the Snap Rings and Washer from the Clutches.
  - c. Remove the Feed and Registration Clutch Assembly and the PWB, release the latches (2).

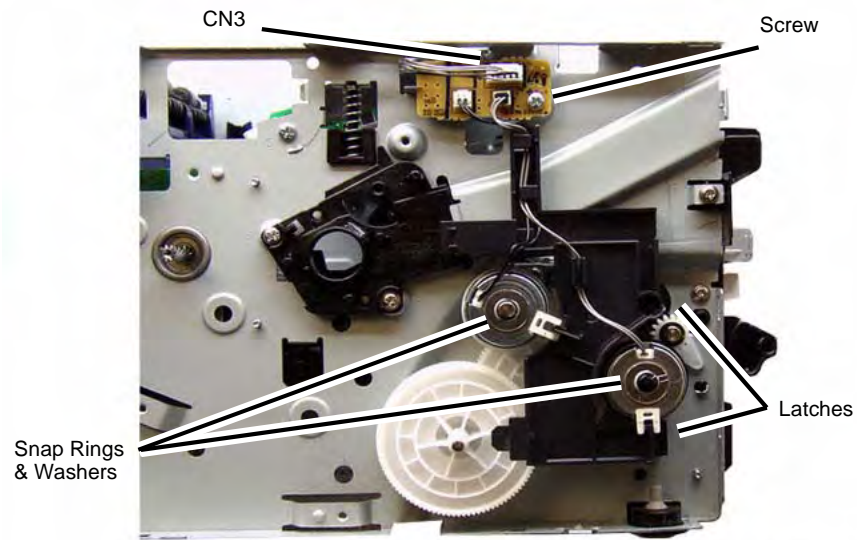

040446RKB

**Figure 3 Feed and Registration Clutch / Feeder PWB**

6. Remove the Feed and Registration Clutch Drive Gears (Figure 4).

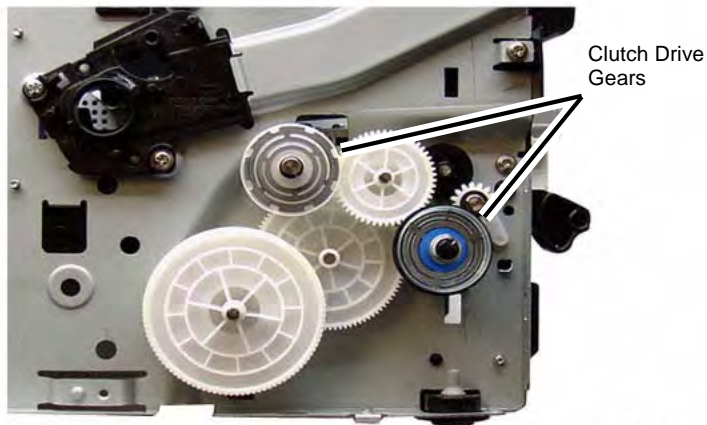

040447RKB

**Figure 4 Feed and Registration Clutch Drive Gears**

7. Remove the following (Figure 5):  
 Make note of the order that the Feed and Registration Drive Gears are removed in so they can be re-installed correctly.
  - a. Feed and Registration Drive Gears, there is a Snap Ring on one gear.
  - b. Feed and Registration Clutch Bushings (2 Snap Rings).
  - c. Exit Drive Gears, (2 screws and a Latch).

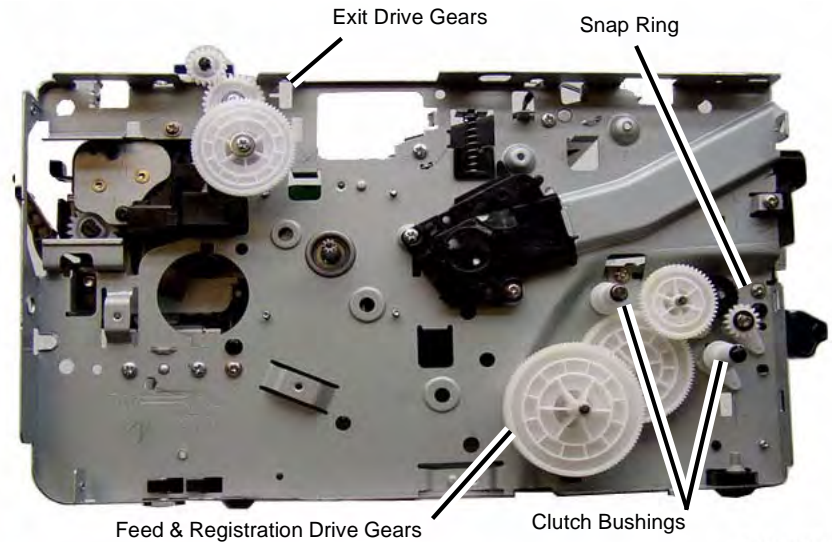

040448RKB

**Figure 5 Drive Gears and Bushings**

8. Remove the following from the Left Frame (Figure 6):
  - a. Shaft Bushings (2), release the latches.
  - b. LSU Support (2 screws).
  - c. Paper Path Module (5 screws).

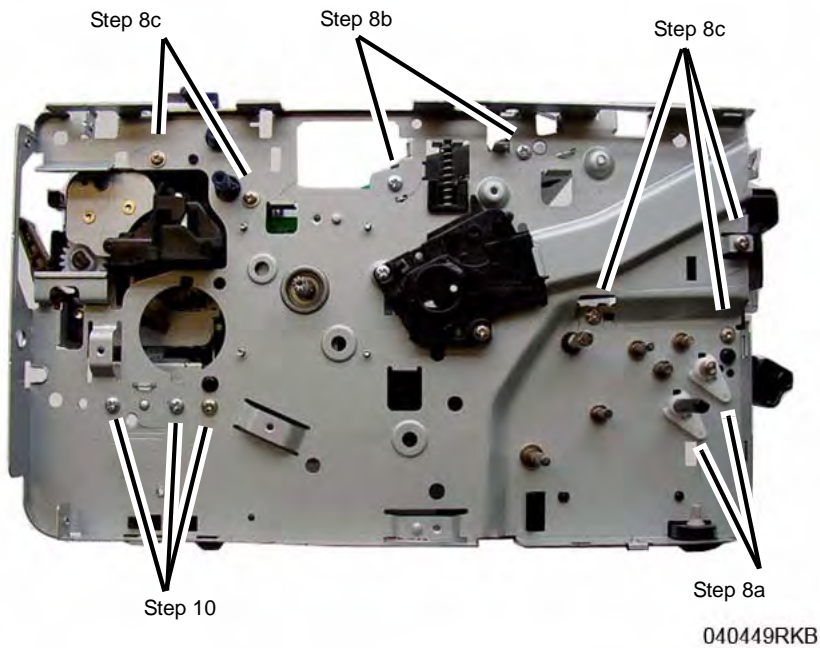
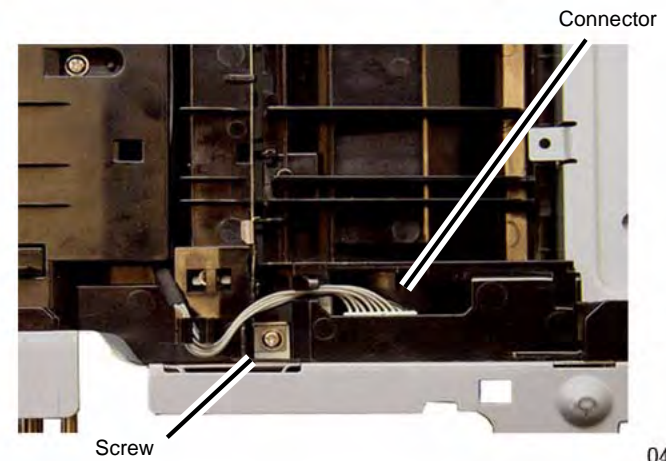

Figure 6 Frame Screw Removal

040449RKB

9. On the bottom of the Printer (Figure 7):
  - a. Disconnect the Printer Drive Motor Connector.
  - b. Remove the screw (1) and the Ground Clip.



040450RKB

Figure 7 Drive Motor Connector & Ground Clip (Bottom View)

10. Remove the Left Frame (3 screws) (Figure 6).
11. Remove the Drive Motor (4 screws) (Figure 8).

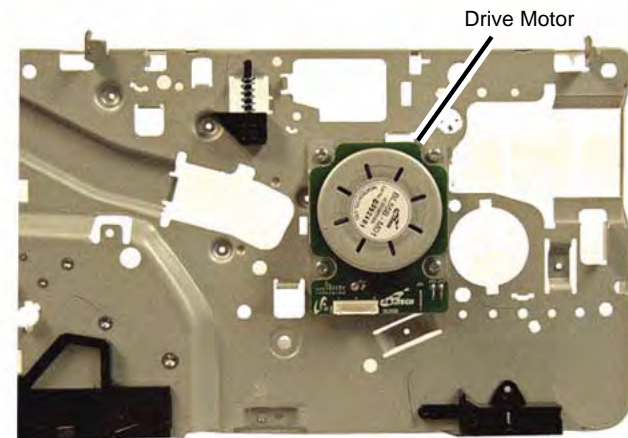

040451RKB

Figure 8 Drive Motor

## Replacement

**NOTE:** Tapered Plastic Screws and Round Machine Screws are used to hold the PWB to the frame. Make sure that the Plastic Screws go into plastic components and Machine Screws go into the metal frame.

Install the components in the reverse of removal.

1. Install the new Drive Motor (4 screws).

**NOTE:** The Frame is flexible and can be bowed out if the screws are not tightened in the correct order.

Reinstall the Frame as follows so it seats flush against the printer internal modules.

2. Align the Frame on to the internal modules and shafts.

**NOTE:** Do Not fully tighten the screws in Step 3 until instructed.

3. Install, but do not tighten, the following module screws (Figure 9):
  - a. The Fuser Module screws (2)
  - b. The Front Paper Path Module screws (3)

- b. Connect the Drive Motor Connector.

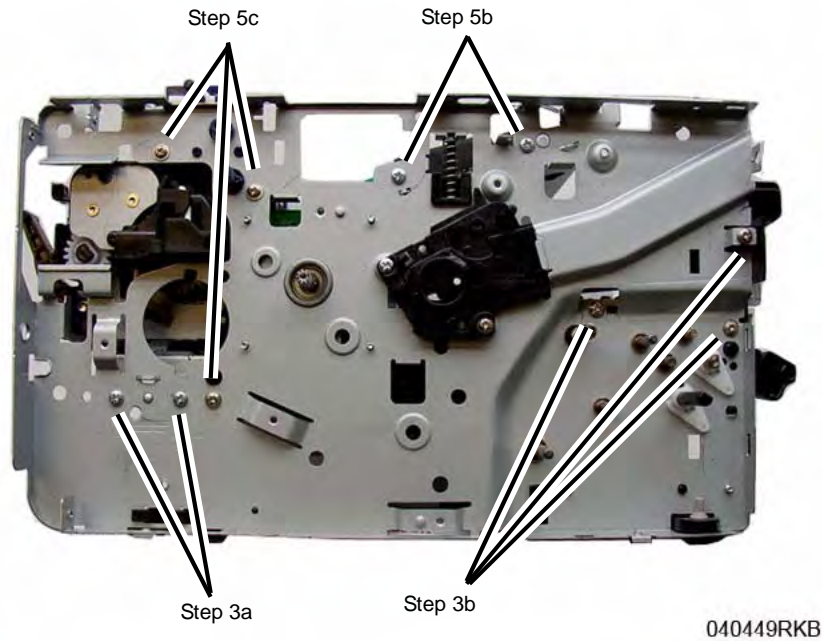
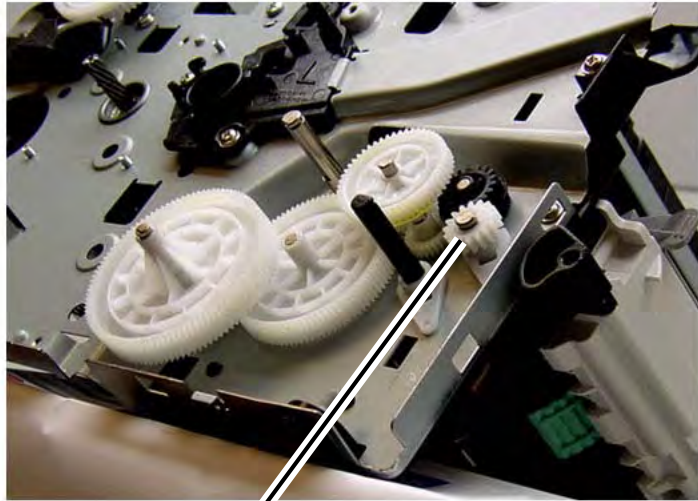

Figure 9 Frame Screw Installation

4. On the bottom of the Printer (Figure 7):
  - a. Install the Ground Clip and screw (1).  
Tighten the screw.

5. Install and tighten the Frame screws from the center of the Frame:  
To the Front of the printer, then to the Rear of the Printer (Figure 9).
  - a. Tighten the Front Paper Path Module screws (3) installed in Step 3b.
  - b. The ROS Support screws (2)
  - c. The Rear Paper Path Module screws (3)
  - d. Tighten all the Fuser Module Screws (2) installed in Step 3a.
6. Reinstall the Drive Gears, and Snap Ring.  
Refer to (Figure 10) for correct installation the Feed and Registration Drive Gears.



Snap Ring

040452RKB

**Figure 10 Feed and Registration Drive Gears**

7. Install the remaining components in the reverse of removal.  
When installing the Front Cover Support Arm make sure it is correctly placed on the Stop Bracket (Figure 11).

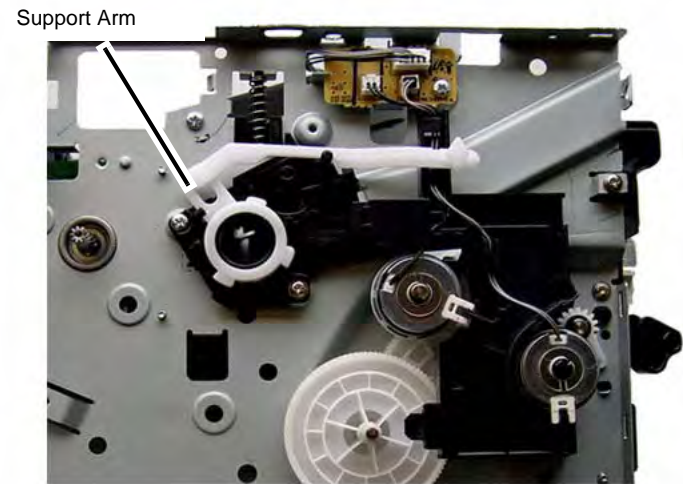

040443RKB

**Figure 11 Front Cover Support Arm Placement**

## REP 1.10 Main Drive Unit

### Parts List on PL 4.6

#### Removal

1. Switch Off the Printer and disconnect the Power Cord.
2. Remove the Left Side Cover (REP 1.2).
3. Remove the screws (5) from the Main Drive Unit (Figure 1).
4. Move the Fuser Drive Locking Lever to the Unlock position (Right) (Figure 1).  
Remove the Main Drive Unit and the Front Door Support Arm.

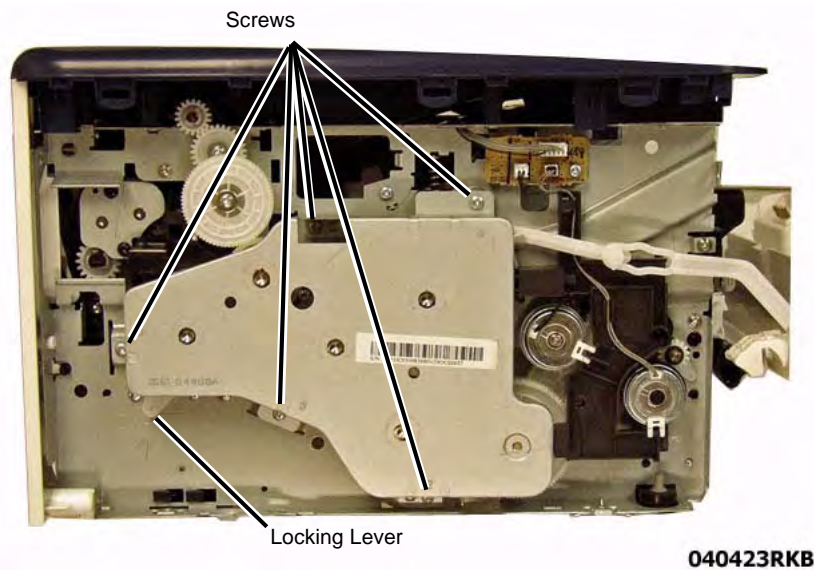

Figure 1 Main Drive Unit Removal

#### Replacement

1. Place the Front Cover Support Arm on the Stop Bracket (Figure 2).

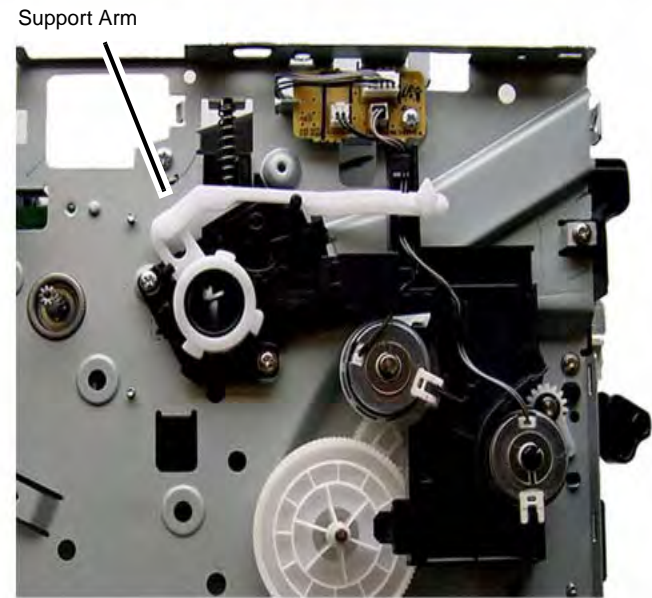
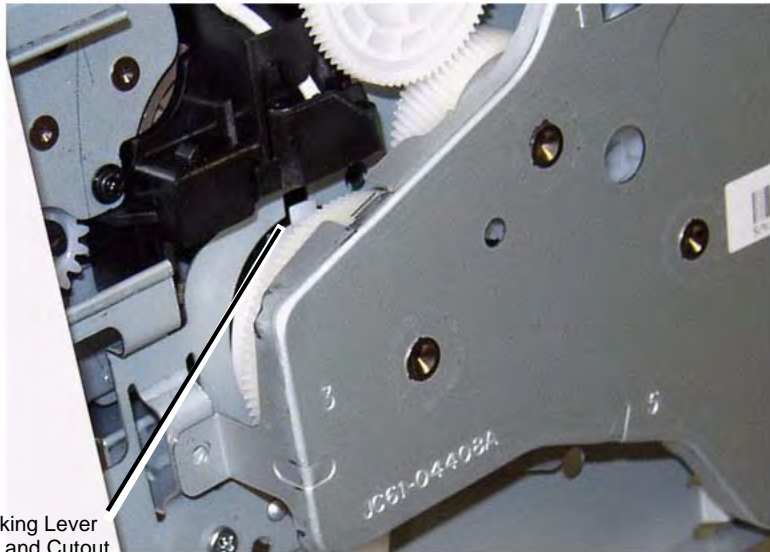

Figure 2 Front Cover Support Arm Placement

2. Reinstall the Main Drive Unit (5 screws).

**NOTE:** Make sure the Tabs (2) on the Locking Lever are inside the Frame cutouts before moving the Fuser Drive Locking Lever to the Lock position.

3. Align the Locking Lever Tabs (2) to the cutouts in the frame (Figure 3).
4. Press in on the Locking Lever to move the Tabs into the cutouts.  
Move the Locking Lever to the Lock position (Left).
5. Install the remaining components in the reverse of removal.



Locking Lever  
Tab and Cutout

040424RKB

Figure 3 Locking Lever Tab and Frame Cutout

## REP 1.11 LSU and Cables

### Parts List on PL 4.1

#### Removal

1. Switch Off the Printer and disconnect the Power Cord.
2. Remove the following covers:
  - a. Remove the Left and Right Side Covers (REP 1.2).
  - b. Remove the Front Cover (REP 1.1).
  - c. Remove the Rear Cover (REP 1.4).
  - d. Remove the Top Cover (REP 1.3).
3. To replace the LSU Cables: (Figure 1).
  - a. Disconnect the cable connector at the LSU.
  - b. Disconnect the cable connector at the Main PWB.

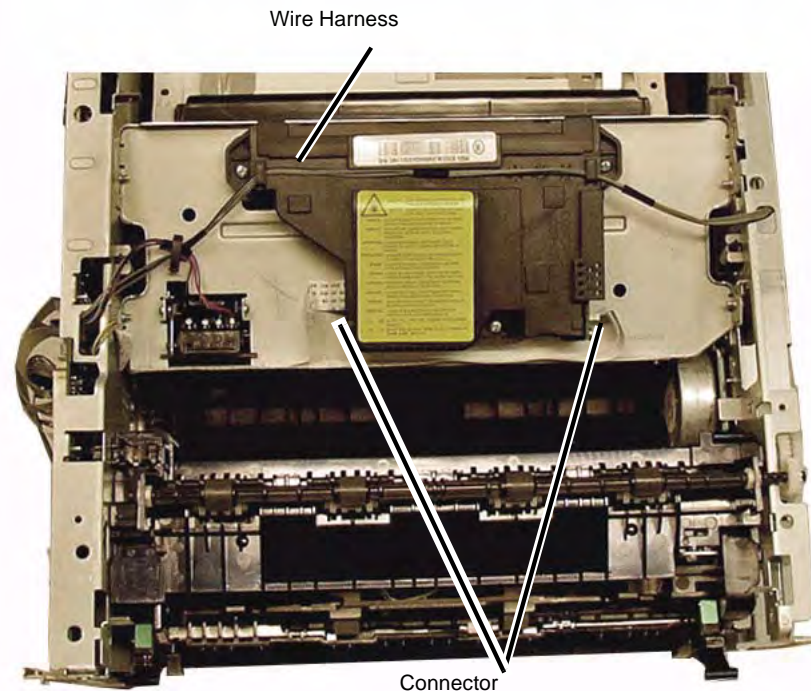

Wire Harness

Connector

040415RKB

Figure 1 LSU Cable Connectors and Wire Harness (Top View)

**NOTE:** The Flat Cable may be adhered to the LSU. Detach it from the LSU and reinstall it on the new LSU in the same location.

4. To replace the LSU:

- a. Release the wire harness from the top of the LSU and disconnect the connectors (2) at the LSU (Figure 1).
- b. Remove the screws (3) (Figure 2).

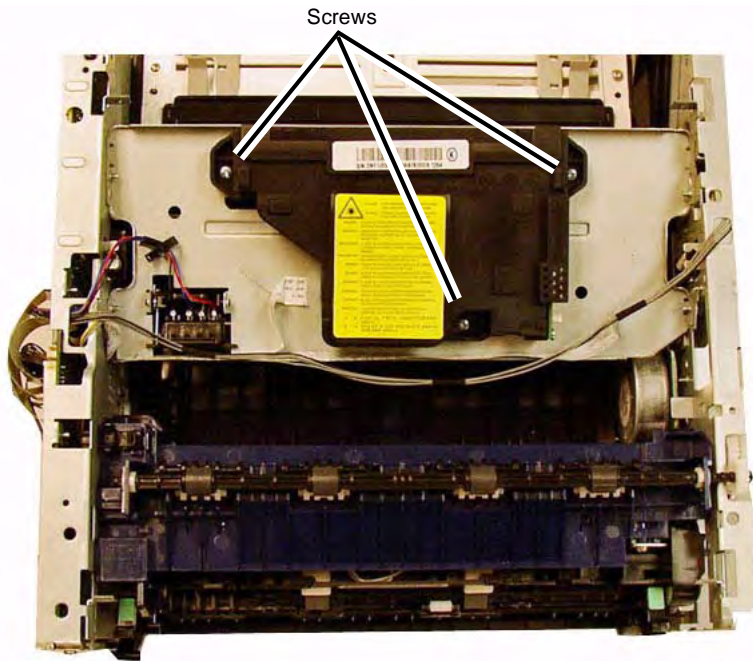

040416RKB

Figure 2 LSU Removal (Top View)

### Replacement

Install the components in the reverse of removal.

## REP 1.12 Retard Roll

### Parts List on PL 6.1

#### Removal

1. Remove the Paper Tray and any paper from the tray.
2. In the Paper Tray, pull down on the latches (2) to open the Retard Roll Cover (Figure 1).

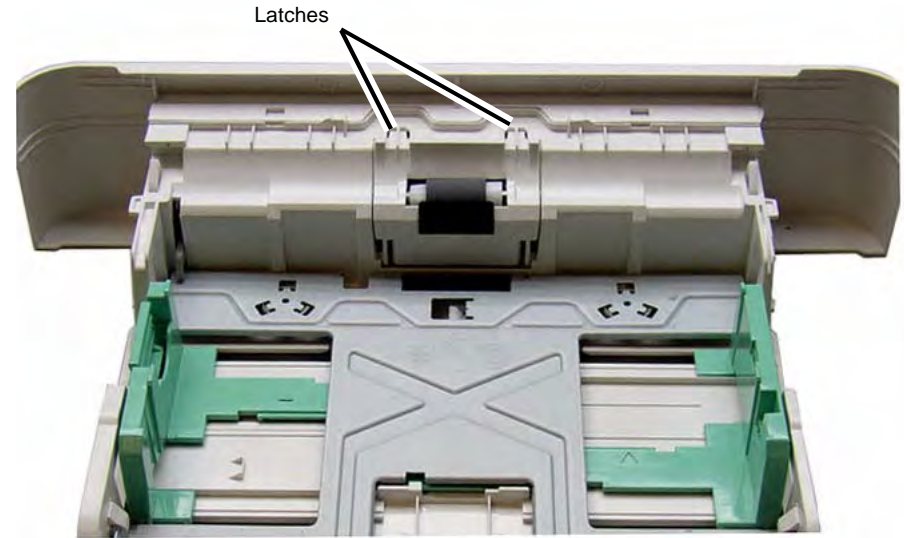

040432RKB

Figure 1 Retard Roll Cover Latches

3. Rotate the Retard Roll Holder up and remove it from the Paper Tray (Figure 2).



Retard Roll Holder

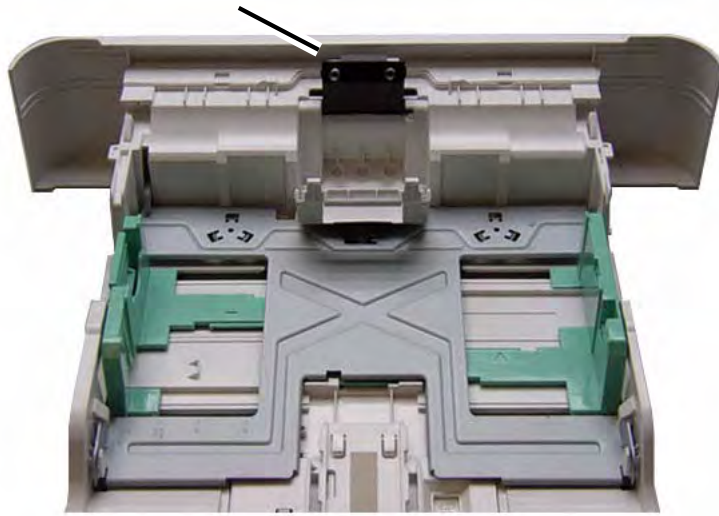

0040433RKB

Figure 2 Retard Roll Holder Removal

4. Sliding the left side of the Retard Roll out of the holder and remove it (Figure 3).

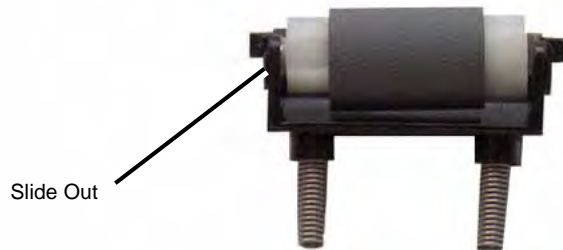

040434RKB

Figure 3 Retard Roll Removal

## Replacement

1. Install the components in the reverse of removal.

**NOTE:** Make sure the Springs (2) on the Retard Roll Holder are correctly positioned on the holes (Figure 4).

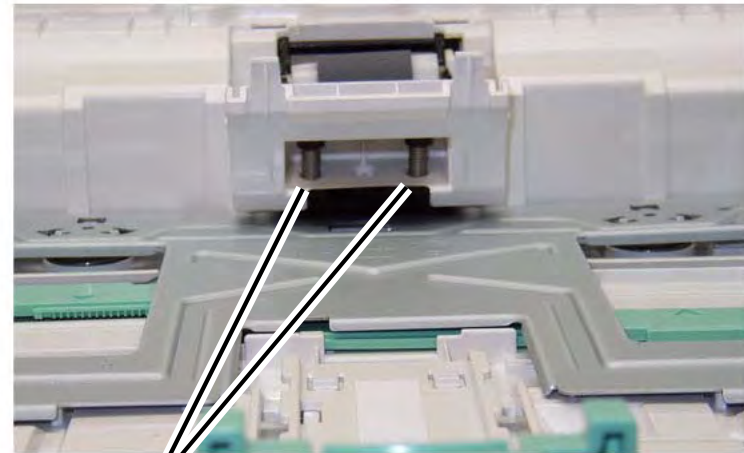

Springs

040435RKB

Figure 4 Springs Located in Holes

## REP 1.13 Feed and Registration Clutches / Paper Feed PWB

### Parts List on PL 4.1

#### Removal

1. Switch Off the Printer and disconnect the Power Cord.
2. Remove the Left Side Cover (REP 1.2).
3. Removing the Paper Feed PWB (Figure 1):
  - a. Disconnect the Connectors (3) on the Paper Feed PWB.
  - b. Remove the Screw (1) and the PWB.
4. Removing the Feeder Clutch (Figure 1)
  - a. Disconnect the Feeder Clutch Connector (CN2) on the Paper Feed PWB and release the wires from the wire clamps.
  - b. Remove the E-ring and Washer from the Feeder Clutch.
  - c. Remove the Feeder Clutch.
5. Removing the Registration Clutch (Figure 1)
  - a. Disconnect the Registration Clutch Connector (CN1) on the Paper Feed PWB and release the wires from the wire clamps.
  - b. Remove the E-ring and Washer from the Registration Clutch.
  - c. Remove the Registration Clutch.

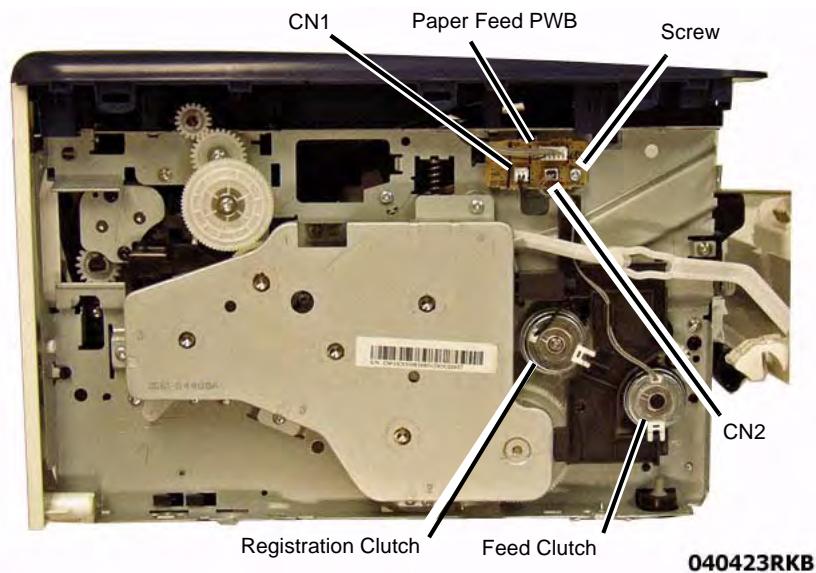

Figure 1 Feed and Registration Clutches / Paper Feed PWB

#### Replacement

Install the components in the reverse of removal.

## REP 1.14 Feed and Registration Sensors PWB and Actuators

### Parts List on PL 4.4

#### Removal

1. Switch Off the Printer and disconnect the Power Cord.
2. Remove the Duplex Assembly (REP 1.18).
3. Set the printer on the Rear Cover (Front of printer facing up).
4. Remove the Bottom Bar (2 screws) (Figure 1).

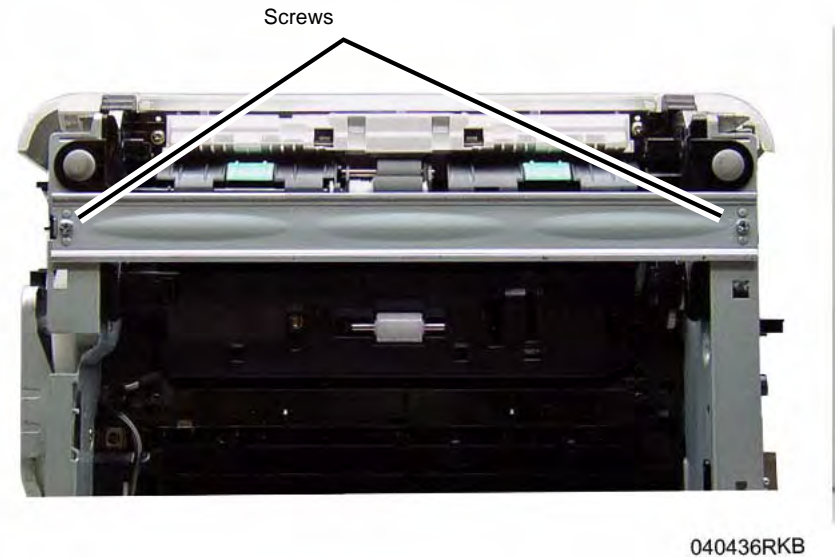
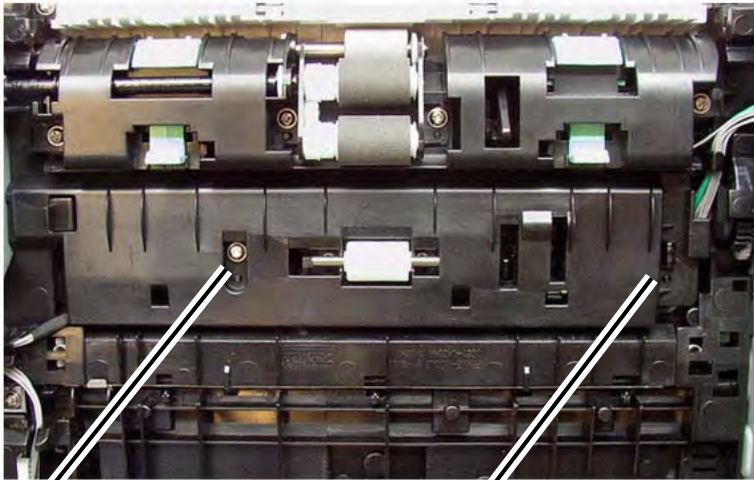

Figure 1 Bottom Bar (Bottom View)

5. Remove the Feed and Registration Sensors PWB Cover (Figure 2).
  - a. Remove the screw (1).
  - b. Release the Latch and remove the cover.



Screw

Latch

040441RKB

Figure 2 Feed and Reg Sensors PWB Cover (Bottom View)

6. Release the Latch and remove the Feed and Registration Sensor PWB (Figure 3).

Sensors PWB

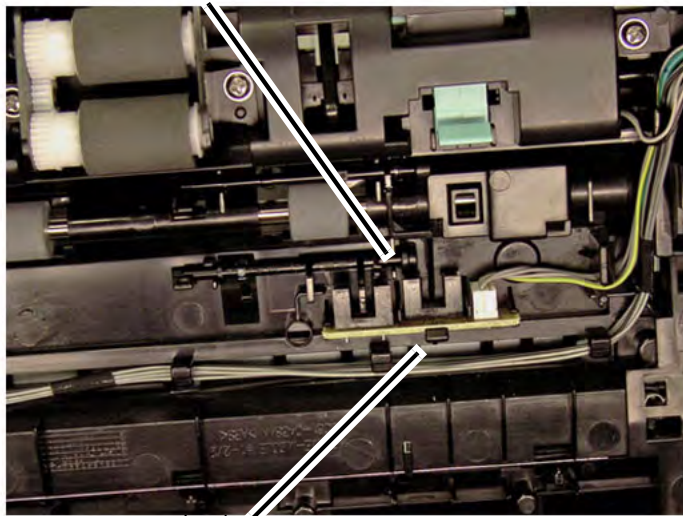

Latch

040442RKB

Figure 3 Feed and Registration Sensors PWB (Bottom View)

7. Removing the Feed and Registration Sensor Actuators (Figure 4):  
Note the location of the Spring in the frame cutout for reinstallation (Figure 5).
  - a. Release the Actuator from the latch.
  - b. Remove the Actuator.

Feed Sensor Actuator

Spring

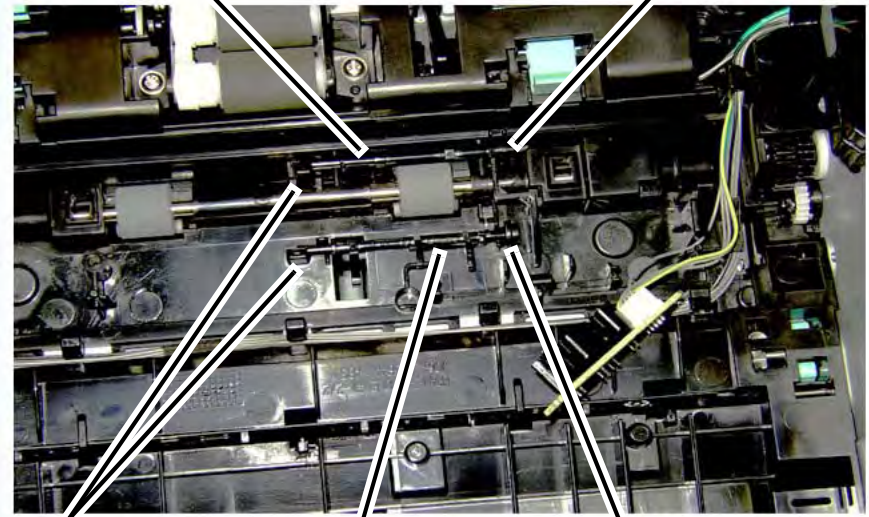

Latch

Reg Sensor Actuator

Spring

040428RBAT

Figure 4 Feed and Registration Sensors Actuators (Bottom View)

### Replacement

**NOTE:** Tapered Plastic Screws and Round Machine Screws are used to hold the cover to the frame. Make sure that the Plastic Screws go into plastic components and Machine Screws go into the metal frame.

Install the components in the reverse of removal.

**NOTE:** When replacing the Actuators make sure the Spring is correctly seated in the cutout in the frame (Figure 5).

Spring Cutouts

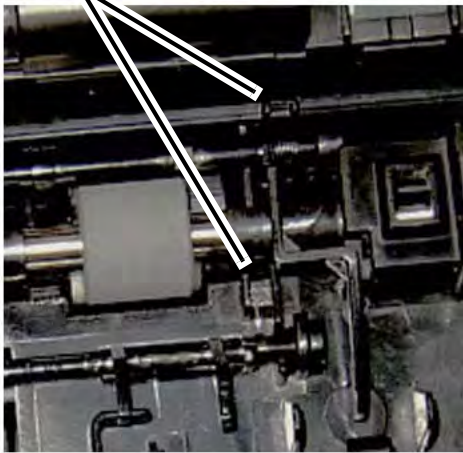

040428aRBAT

Figure 5 Actuator Spring Cutouts (Bottom View)

## REP 1.15 Feed and Forward Roll Assembly

### Parts List on PL 4.4

#### Removal

1. Switch Off the Printer and disconnect the Power Cord.
2. Remove the Paper Cassette.
3. Remove the Left and Right Side Covers (REP 1.2).
4. Set the printer so the Front of the printer facing up.

**NOTE:** The Feed and Forward Roll Assembly screws are different from the Bottom Bar screws. Observe the screw locations for correct replacement.

5. Remove the Bottom Bar (2 screws) (Figure 1).

Screws

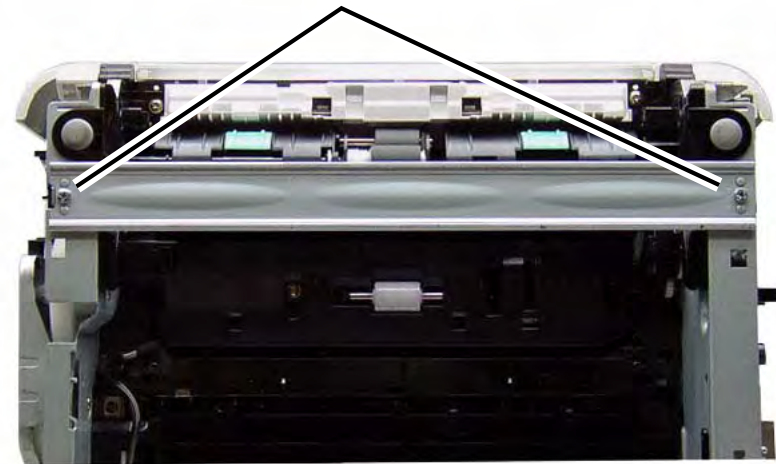

040436RKB

Figure 1 Removing the Bottom Bar (Bottom View)

6. Remove the Feed and Forward Roll Assembly (Figure 2):
  - a. Remove the screws (2)
  - b. Pull the right side of the assembly out, then slide the assembly out to the right.

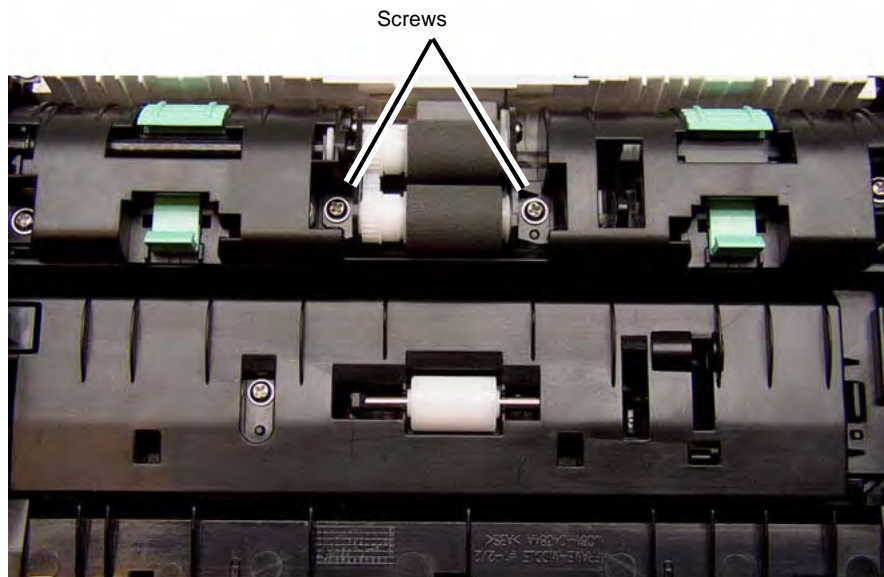

040437RKB

Figure 2 Removing the Feed and Forward Roll Assembly (Bottom View)

7. Remove the Feed and Forward Rolls from the assembly (Figure 3).



040438RKB

Figure 3 Removing the Feed and Forward Roll

## Replacement

Install the components in the reverse of removal.

**NOTE:** Tapered Plastic Screws and Round Machine Screws are used to hold the cover to the frame. Make sure that the Plastic Screws go into plastic components and Machine Screws go into the metal frame.

**NOTE:** When replacing the Feed and Forward Roll Assembly make sure the Flat on the Bushing is lined up with the Flat on the Assembly (Figure 4).

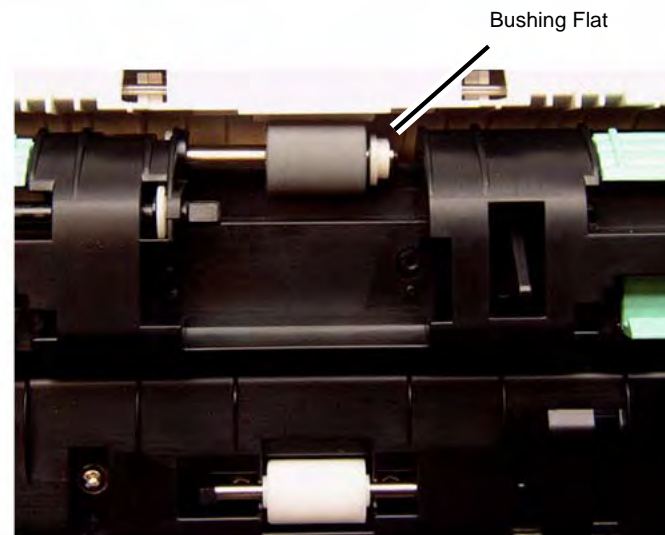

040439RKB

Figure 4 Bushing Flat (Bottom View)

## REP 1.16 Transfer Roll

### Parts List on PL 4.1

#### Removal

1. Open the Front Cover.

**NOTE:** Cover the Drum Cartridge with several sheets of paper to prevent it from being light shocked.

2. Remove the Toner Cartridge and the Drum Cartridge.
3. Remove (squeeze and lift) the Transfer Roll Retainer Clip (Figure 1).

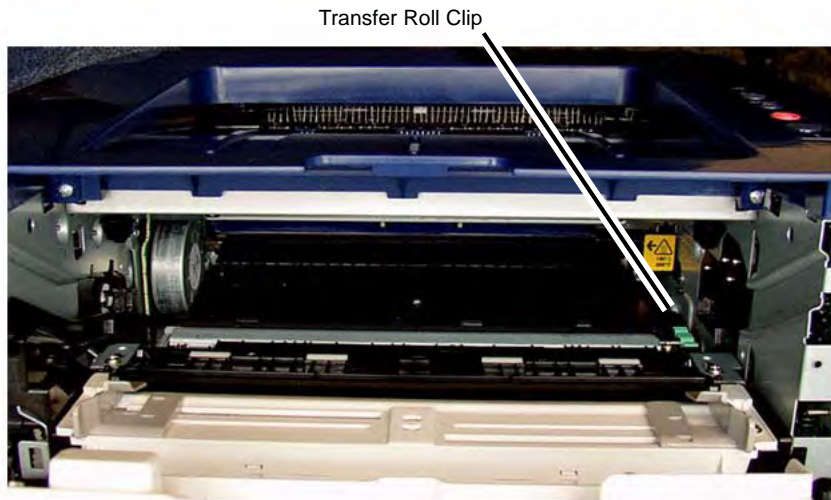

0404021RKB

Figure 1 Transfer Roll Retainer Clip

4. Remove the Transfer Roll (Figure):
  - a. Lift the right end of the Transfer Roll and slide the left end out of the bushing (Figure 2).



040422RKB

Figure 2 Removing the Transfer Roll

#### Replacement

Install the components in the reverse of removal.

## REP 1.17 Fuser Module

### Parts List on PL 5.1

#### Removal

#### WARNING

Do not perform repair activities with the power on or electrical power supplied to the machine. Some machine components contain dangerous electrical voltages that can result in electrical shock and possible serious injury.

**DANGER:** Ne pas effectuer de dépannage avec le contact principal activé ou avec l'alimentation électrique appliquée à la machine. Certains éléments de la machine comportent des tensions électriques dangereuses qui peuvent causer un choc électrique et de graves blessures.

**AVVERTENZA:** Non effettuare alcuna riparazione con l'alimentazione elettrica inserita. Alcuni componenti contengono corrente ad alta tensione che può provocare forti scosse e gravi ferite.

**VORSICHT:** Es dürfen erst Reparaturarbeiten durchgeführt werden, wenn das Gerät ausgeschaltet ist oder der Netzstecker nicht mehr mit der Stromquelle verbunden ist. Einige Komponenten des Gerätes sind stromführend und können daher zu ernsthaften Verletzungen oder Stromschlägen führen.

**AVISO:** No realice reparaciones con la máquina encendida o conectada a la corriente. Algunos componentes de la máquina contienen voltajes eléctricos peligrosos que pueden producir una descarga eléctrica y causar daños graves.

#### WARNING

Do not handle the fuser components until they have cooled. Some fuser components operate at hot temperatures and can produce serious personal injury if touched.

**DANGER:** Ne pas manipuler les éléments du four avant de les laisser refroidir. Certains éléments du four fonctionnent à des températures très élevées et peuvent causer de graves blessures s'ils sont touchés.

**AVVERTENZA:** Non maneggiare i componenti del fusore finché non sono raffreddati. Alcuni di questi componenti funzionano ad alte temperature e possono provocare gravi ferite se vengono toccati.

**VORSICHT:** Die Fixieranlage sollte erst gehandhabt werden, wenn diese genügend abgekühlt ist. Einige Teile der Fixieranlage erzeugen übermäßige Hitze und führen bei der Berührung zu schweren Verbrennungen.

**AVISO:** No manipule los componentes del fusor antes de que se enfríen. Algunos de los componentes del fusor funcionan a altas temperaturas y pueden ocasionar daños personales graves si se los toca.

1. Switch Off the Printer and disconnect the Power Cord.
2. Remove the following covers:
  - a. Remove the Left and Right Side Covers (REP 1.2).
  - b. Remove the Rear Cover (REP 1.4).

3. Disconnect the Fuser Connectors (2) (Figure 1).
  - a. Connector CON 2 from the LVPS PWB.
  - b. Connector FUSER from the Main PWB.

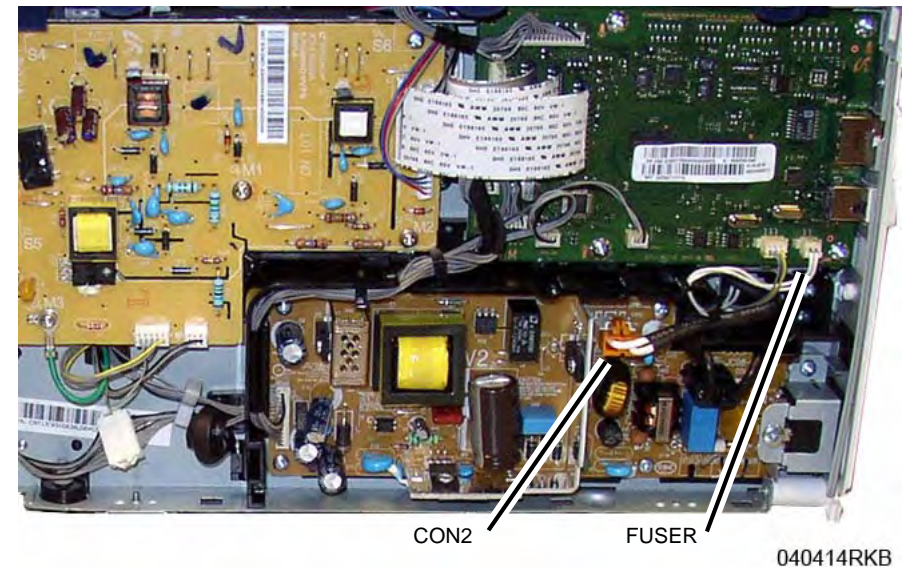
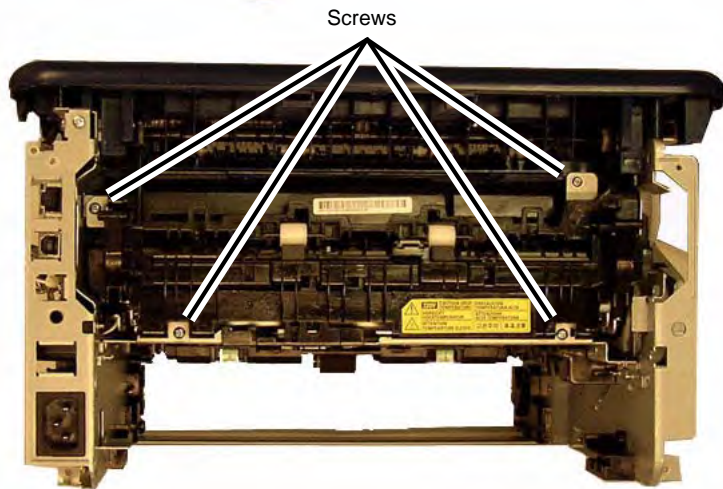

Figure 1 Fuser Connectors

**NOTE:** Remember the location of the Screw with the larger head for Fuser replacement.

4. Remove the Fuser Module screws (4) (Figure 2).  
Remove the Fuser, routing the wires through the frame opening.



040425RKB

Figure 2 Fuser Screws (Rear View)

### Replacement

**NOTE:** Tapered Plastic Screws and Round Machine Screws are used to hold the Fuser to the frame. Make sure that the Plastic Screws go into plastic components and Machine Screws go into the metal frame.

Install the components in the reverse of removal.

## REP 1.18 Duplex Assembly

### Parts List on PL 4.2

#### Removal

1. Switch Off the Printer and disconnect the Power Cord.
2. Remove the Paper Cassette.
3. Remove the following covers:
  - a. Remove the Left and Right Side Covers (REP 1.2).
  - b. Remove the Rear Cover (REP 1.4).

**NOTE:** The Rear Cover holds the Duplex Assembly Pivot in the frame cutout. With the Rear Cover removed, the assembly will come out of the pivot when the front latches are released.

4. Remove the Duplex Assembly:
  - a. From the front of the printer press the Duplex Assembly release tabs (2) (Figure 1).
  - b. From the rear of the printer slide the Duplex Assembly off the pivots to remove it (Figure 2).

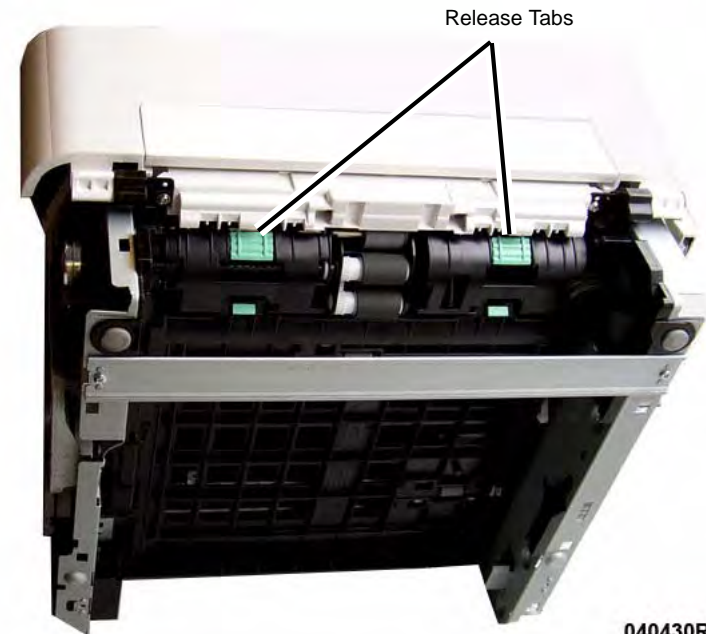

040430RKB

Figure 1 Duplex Assembly Release Tabs (Bottom View)



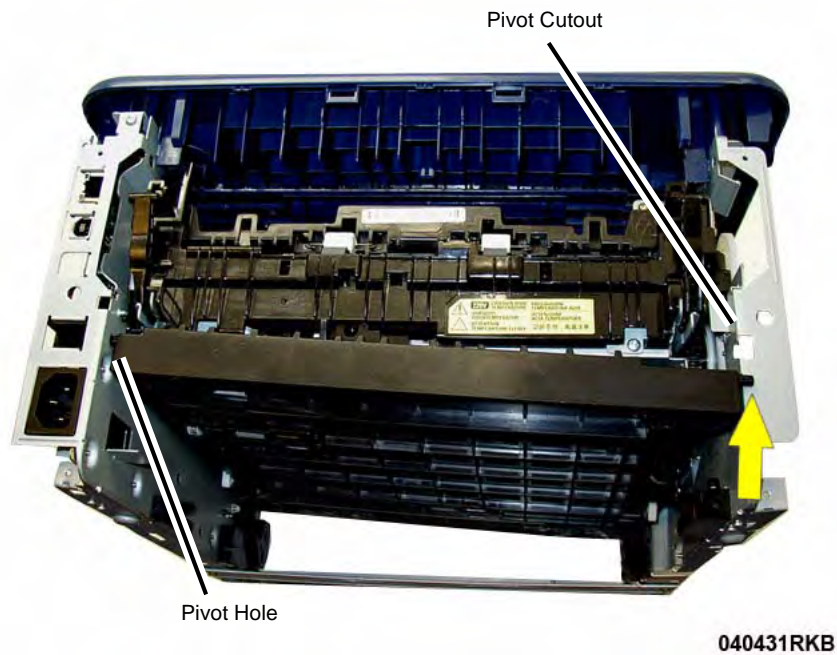

Figure 2 Duplex Assembly Pivots (Rear View)

040431RKB

### Replacement

Install the components in the reverse of removal.

1. Insert the pivot on the left side into the hole.
2. Insert the right pivot into the frame cutout.
3. Lift and latch the front of the Duplex Assembly into position (Figure 2).

## REP 1.19 Exit Sensor

### Parts List on PL 4.1

#### Removal

1. Switch Off the Printer and disconnect the Power Cord.
2. Remove the following covers:
  - a. Remove the Left and Right Side Covers (REP 1.2).
  - b. Remove the Rear Cover (REP 1.4).
3. Remove the Fuser Module (REP 1.17)
4. Press the Latch on the underside of the frame to release the Exit Sensor Mounting Plate from the frame (Figure 1).

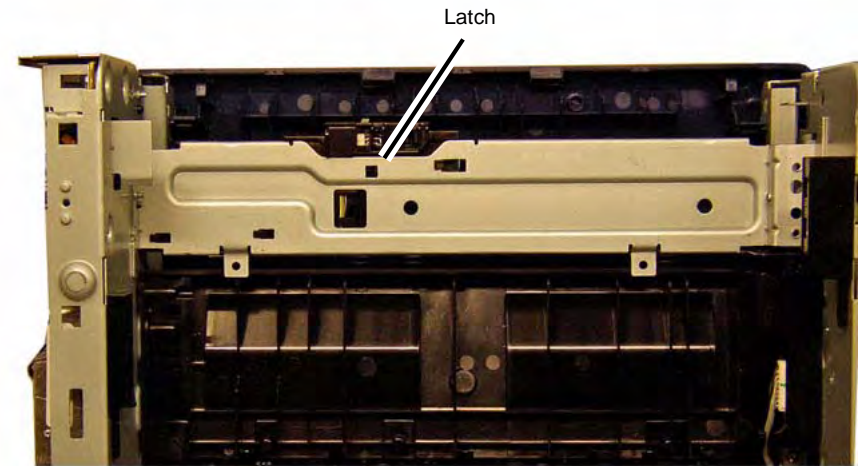
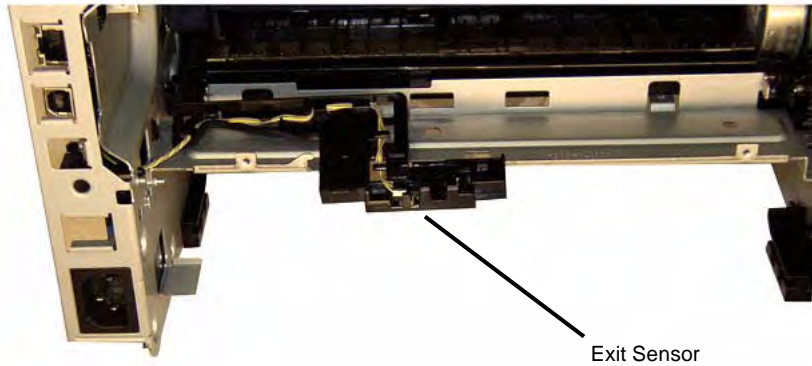

Figure 1 Exit Sensor Plate Latch Release (Bottom View)

040426RKB

5. Remove the Exit Sensor (Figure 2):
  - a. Release the wires from the cable clamps.
  - b. Unlatch and remove the Exit Sensor, disconnect the connector.



040427RKB

Figure 2 Exit Sensor Removal (Rear View)

### Replacement

Install the components in the reverse of removal.

## REP 1.20 Output Tray Full Sensor

Parts List on PL 4.3

### Removal

1. Switch Off the Printer and disconnect the Power Cord.
2. Remove the following covers:
  - a. Remove the Left and Right Side Covers (REP 1.2).
  - b. Remove the Rear Cover (REP 1.4).
  - c. Remove the Top Cover (REP 1.3).

**NOTE:** Do not disconnect the connectors to the Main PWB. The PWB only needs to be moved away from the frame to access the Output Tray Full Sensor.

**NOTE:** Mark the location of the Ground Screw, with larger head, so it can be re-installed in the correct location.

3. Remove the screws (5) to move the Main PWB away from the printer frame (Figure 1).

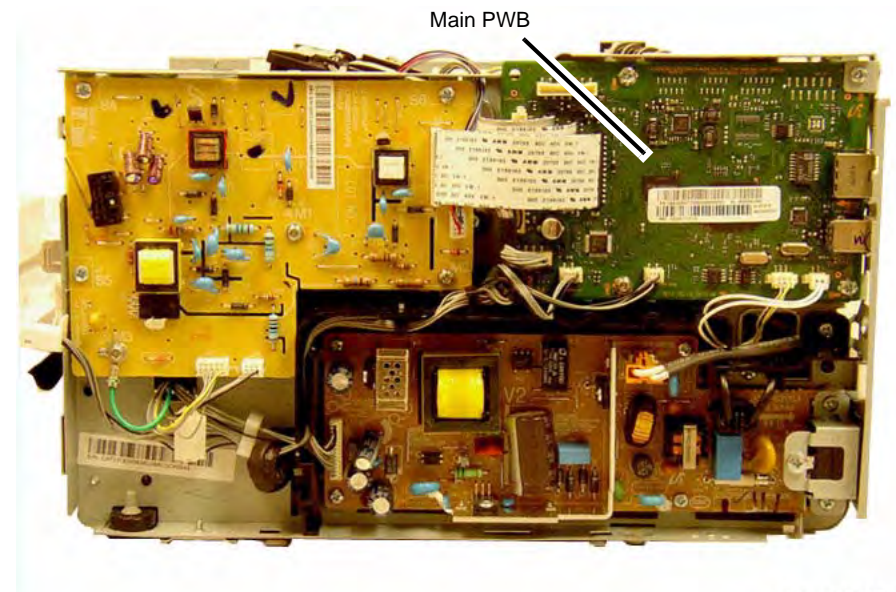

040407RKB

Figure 1 Main PWB

4. Remove the Output Tray Full Sensor (Figure 2):
  - a. Disconnect the Sensor connector.
  - b. Unlatch and remove the Output Tray Sensor.

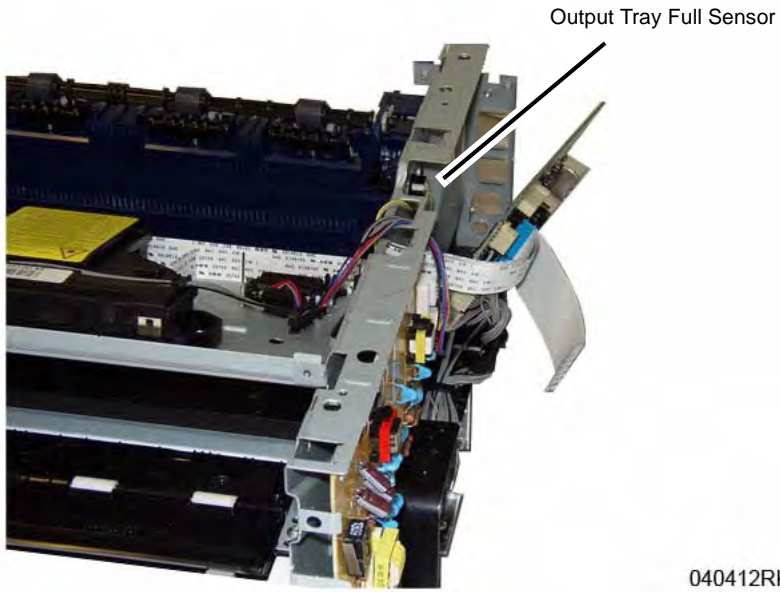

Figure 2 Output Tray Full Sensor (Top Right View)

### Replacement

**NOTE:** When re-installing the Main PWB make sure the ground screw, with large head, is re-installed in the correct location.

Install the components in the reverse of removal.

## REP 1.21 WNPC (WiFi) PWB

### Parts List on PL 1.1

#### Removal

1. Switch Off the Printer and disconnect the Power Cord.
2. Remove the following covers:
  - a. Remove the Left and Right Side Covers (REP 1.2).
  - b. Remove the Rear Cover (REP 1.4).
  - c. Remove the Top Cover (REP 1.3).
3. Disconnect the following connectors from the Main PWB (Figure 1):
  - a. Control Panel Connector.
  - b. WNPC PWB Connector.

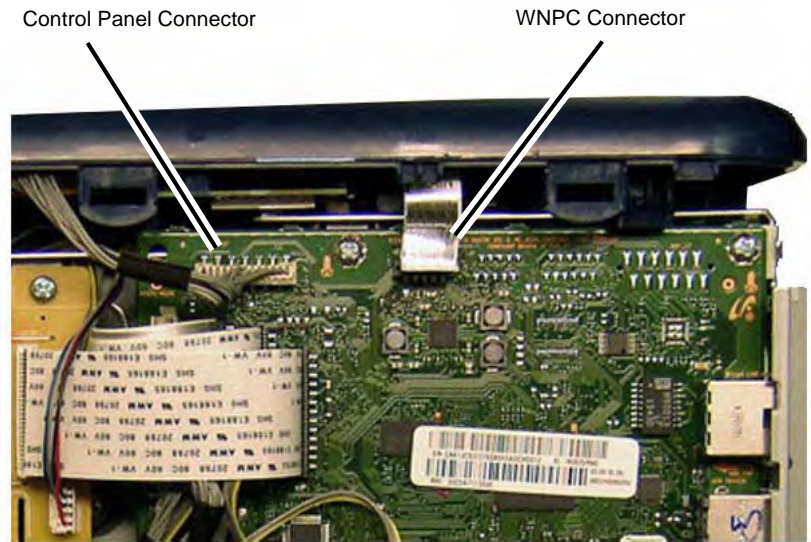
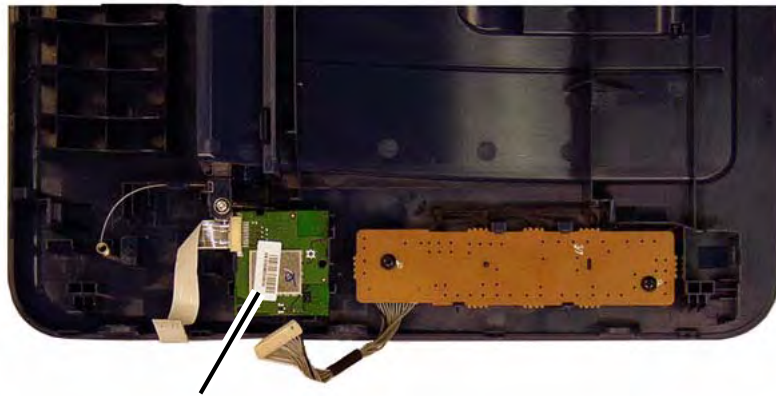

Figure 1 Main PWB Connectors to Disconnect

4. Release the WNPC PWB from the latches and remove it (Figure 2).



WNPC PWB

Figure 2 WNPC PWB (Underside of Top Cover)

040429RKB

### Replacement

Install the components in the reverse of removal.

## REP 1.22 Exit Roll and Bushings

### Parts List on PL 4.3

#### Removal

1. Switch Off the Printer and unplug the Power Cord.
2. Remove the following covers:
  - a. Remove the Left and Right Side Covers (REP 1.2).
  - b. Remove the Rear Cover (REP 1.4).
  - c. Remove the Top Cover (REP 1.3).
3. Remove the Exit Roll and Bushings (Figure 1).
  - a. Remove the Drive Gear, release the latch.
  - b. Remove the Bushings (2), release the latch and rotate the bushing.
  - c. Remove the Exit Roll.

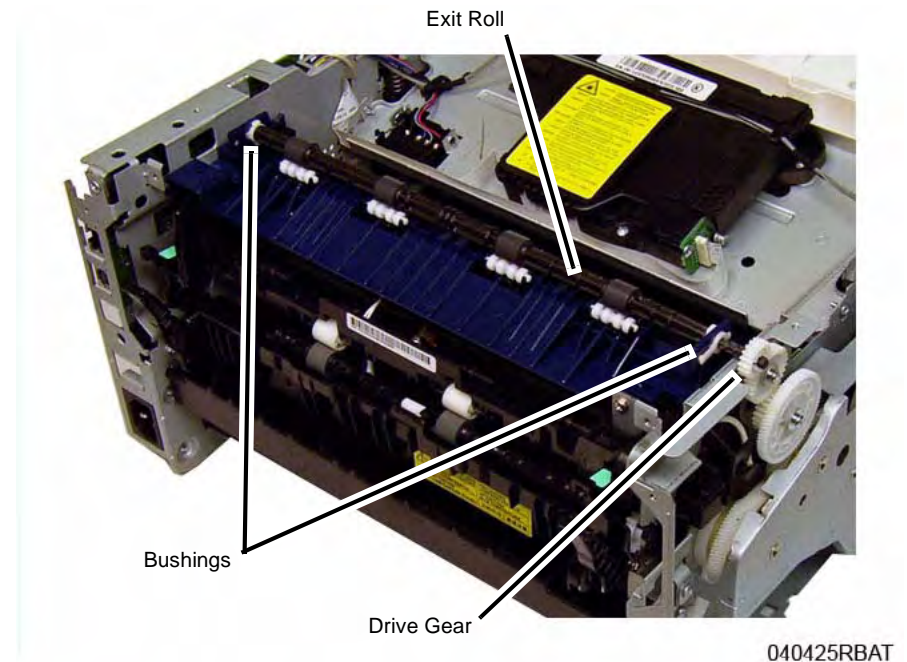

Figure 1 Exit Roll and Bushing (Top View)

### Replacement

Install the components in the reverse of removal.

## REP 1.23 Manual Paper Tray

### Parts List on PL 4.4

#### Removal

1. Switch Off the Printer and unplug the Power Cord.
2. Remove the following covers:
  - a. Remove the Left and Right Side Covers (REP 1.2).
  - b. Remove the Rear Cover (REP 1.4).
  - c. Remove the Top Cover (REP 1.3).
3. Remove the Manual Paper Tray bottom screws (2) (Figure 1).

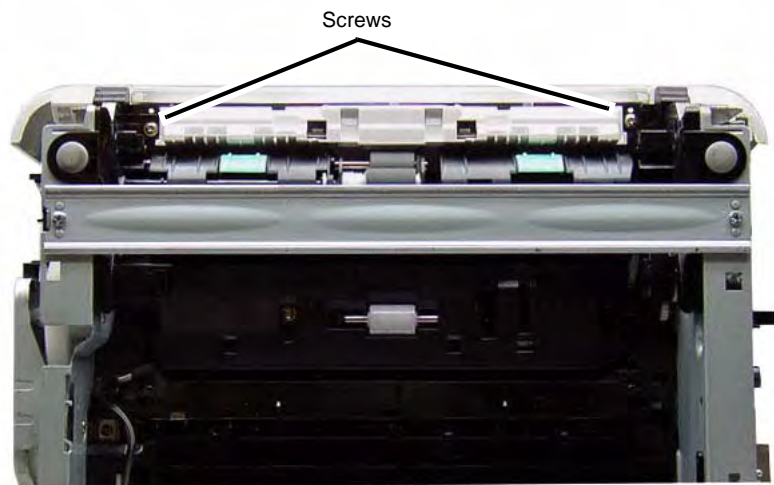

040436RKB

Figure 1 Manual Paper Tray Bottom Screws (Bottom View)

4. Remove the Manual Paper Tray top screws (2) and the paper tray (Figure 2).

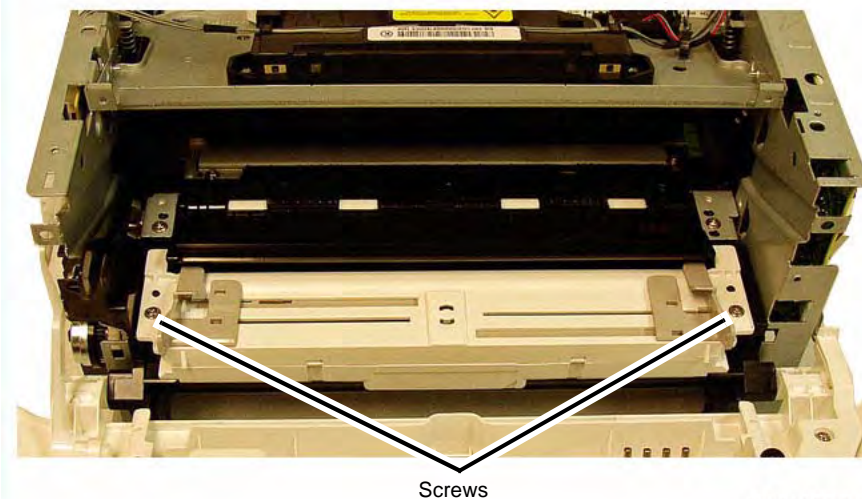

040437RBAT

Figure 2 Manual Paper Tray Top Screws (Top View)

#### Replacement

Install the components in the reverse of removal.

## REP 1.24 Feed Idler Gear

### Parts List on PL 4.6

#### Removal

1. Switch Off the Printer and disconnect the Power Cord.
2. Remove the Left Side Cover (REP 1.2).
3. Remove the Feed Clutch and Drive Gear (Figure 1):
  - a. Remove the E-ring and Washer from the Feeder Clutch.
  - b. Remove the Feeder Clutch and Drive Gear.

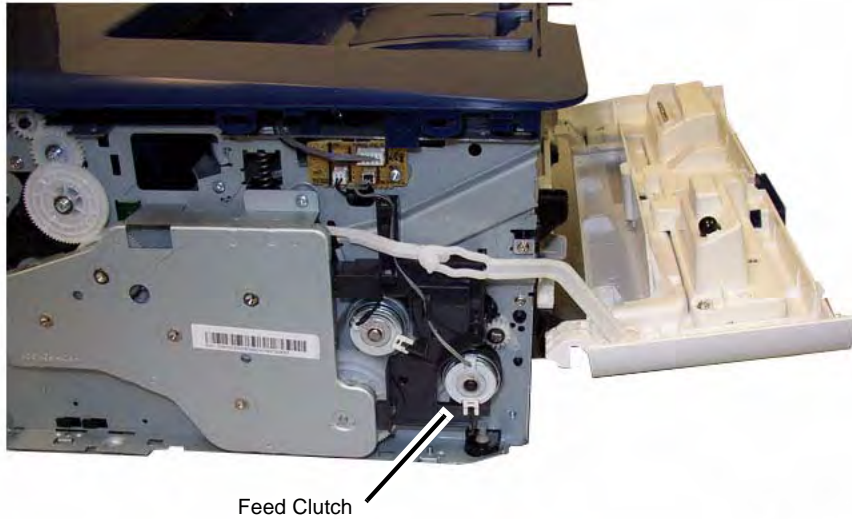

Feed Clutch

Figure 1 Feed Clutch Removal

040401RKB

4. Remove the Snap Ring and Idler Gear (Figure 2).

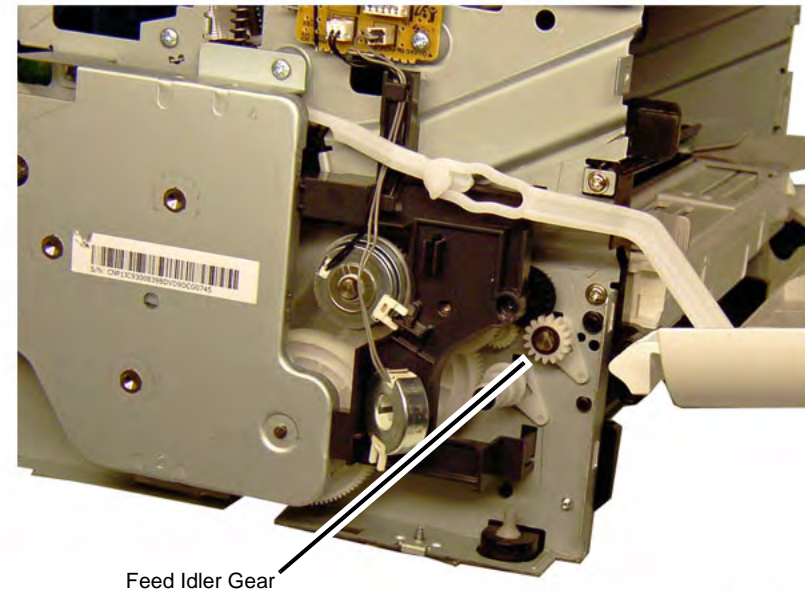

Feed Idler Gear

Figure 2 Feed Idler Gear

040427RBAT

#### Replacement

Install the components in the reverse of removal.

## REP 1.25 Paper Drive Roll

### Parts List on PL 4.5

#### Removal

1. Switch Off the Printer and unplug the Power Cord.
2. Remove the Top Cover (REP 1.3).
3. Disconnect connector CN6 from the HVPS PWB, and route the wires through the frame (Figure 1).

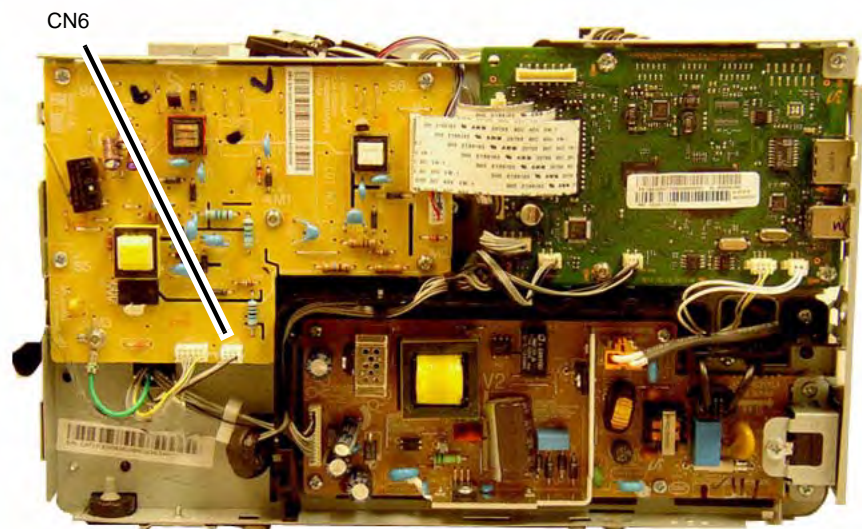

04047aRKB

Figure 1 HVPS CN6

4. Remove the Main Drive Unit (5 screws) and move the Fuser Drive Locking Lever to the Unlock position (Right) (Figure 2).

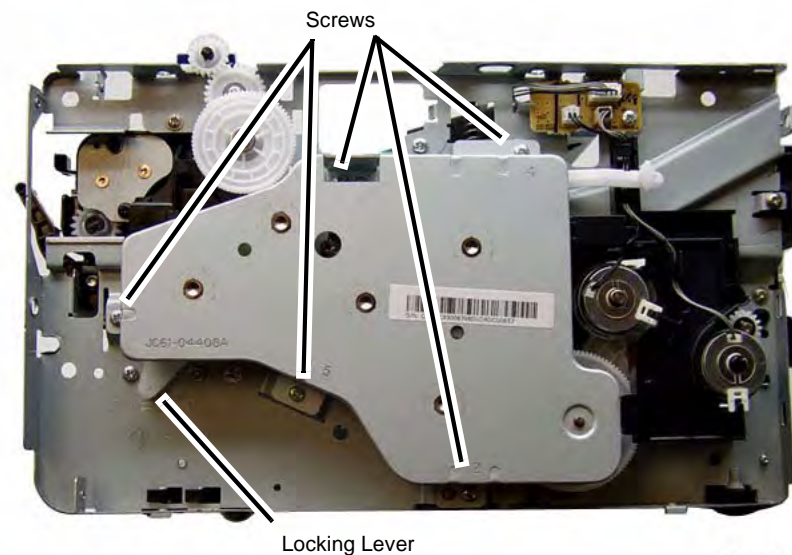

040445RKB

Figure 2 Main Drive Unit

5. Perform the Following (Figure 3):
  - a. Disconnect CN3 from the paper Feed PWB, and remove the screw (1).
  - b. Remove the Feed and Registration Clutches, remove the Snap Rings and Washer from the Clutches.
  - c. Remove the Feed and Registration Clutch Assembly and the PWB, release the latches (2).

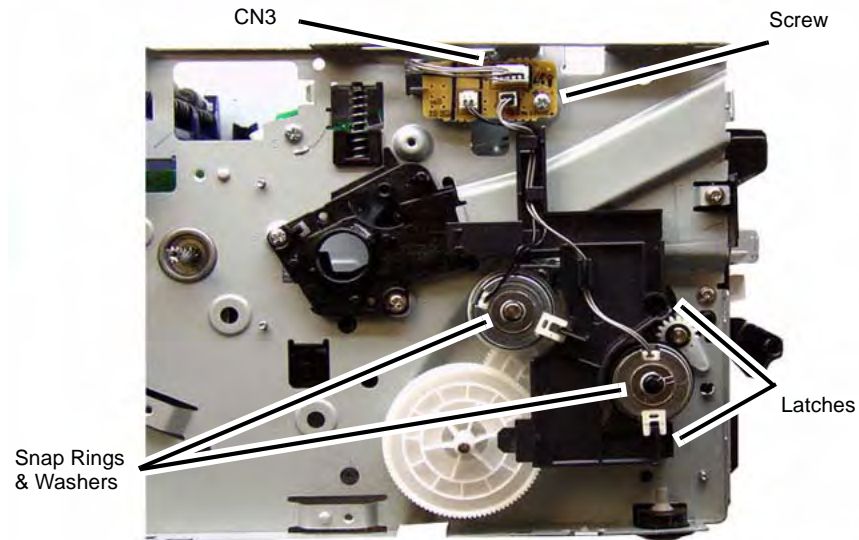

040446RKB

**Figure 3 Feed and Registration Clutch / Paper Feed PWB**

6. Remove the Feed and Registration Clutch Drive Gears (Figure 4).

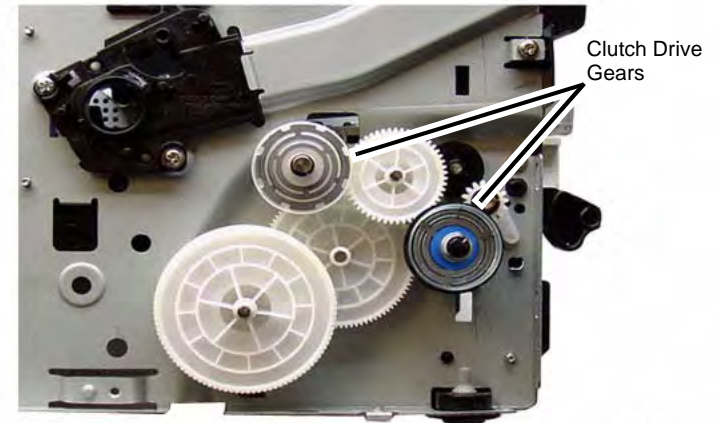

040447RKB

**Figure 4 Feed and Registration Clutch Drive Gears**



7. Remove the following (Figure 5):
  - a. Drive Gears (2).
  - b. Feed Clutch Bushing, remove the Snap Ring.
  - c. Feed Shaft Bushings (2), release the latch and rotate the bushing.
  - d. Feed Assembly screw (1).

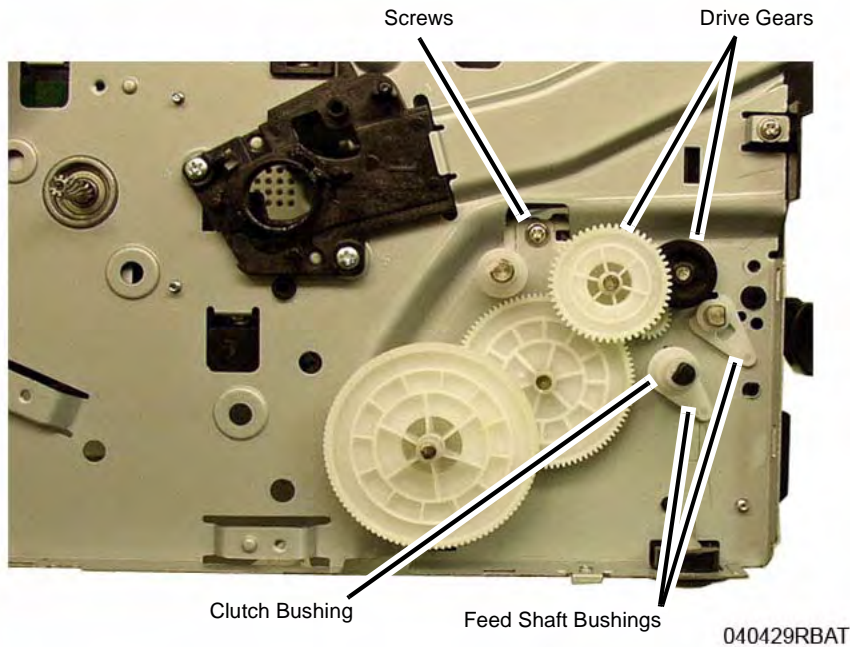

Figure 5 Feeder Drives

040429RBAT

8. Remove the Feed Assembly bottom screws (2) (Figure 6).

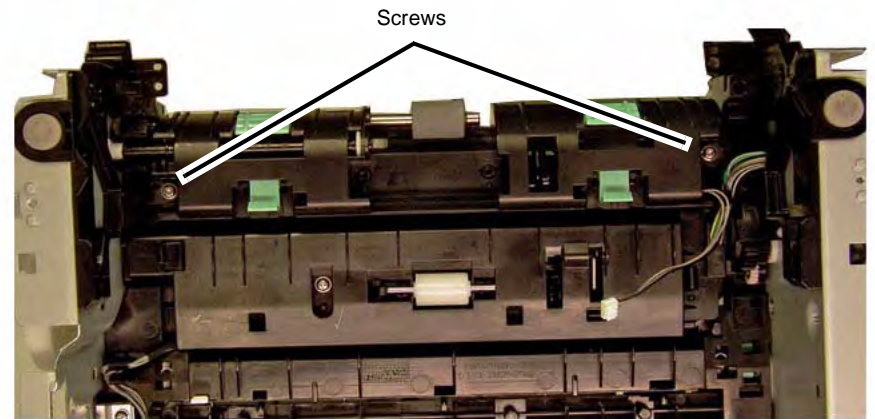

Figure 6 Feeder Assembly Bottom Screws (Bottom View)

040430RBAT

**CAUTION**

*The Brackets holding the Registration Pinch Rolls and Guide are Spring Loaded. Maintain light pressure on the Brackets when removing them to avoid damaging parts or personal injury.*

9. Remove the Registration Pinch Rolls and Paper Guide Brackets (2 screws) (Figure 7):

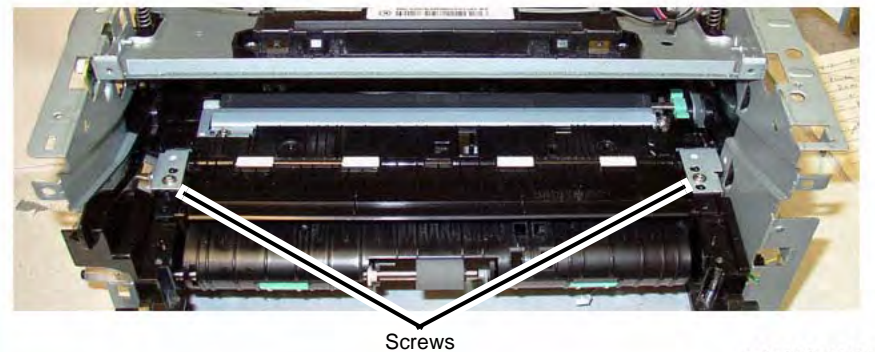
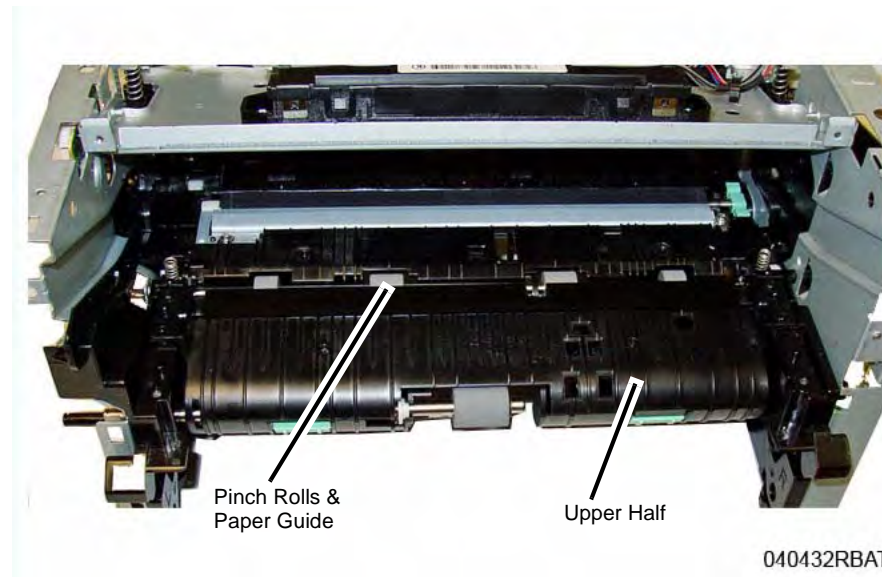

Figure 7 Registration Pinch Rolls and Paper Guide Brackets

040431RBAT

10. Remove the following (Figure 8):
  - a. Lift the Pinch Rolls and Paper Guide out of the printer.
  - b. Remove the Feed Assembly upper half.



**Figure 8 Registration Pinch Rolls and Paper Guide**

11. Remove the following (Figure 9):
  - a. The Feed Assembly lower half.
  - b. The Drive Roll from the lower half.

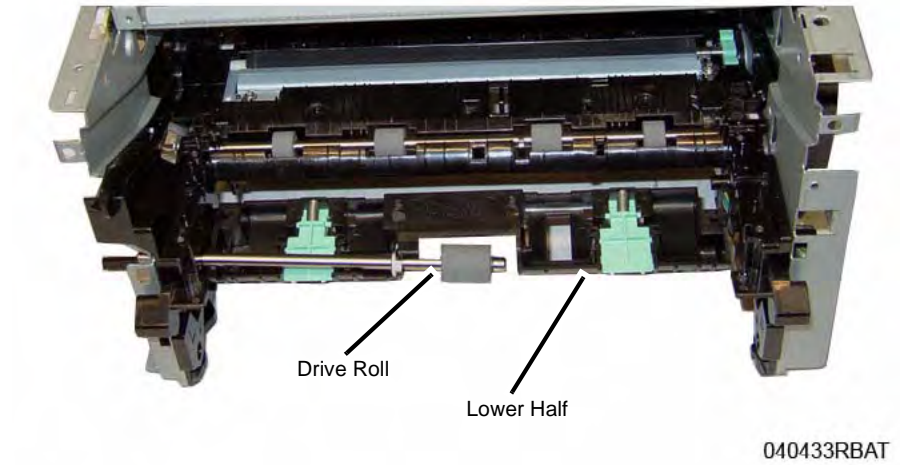

**Figure 9 Feed Assembly Lower Half**

12. Remove the Snap Rings and Bushing from the Drive Roll Shaft (Figure 10).

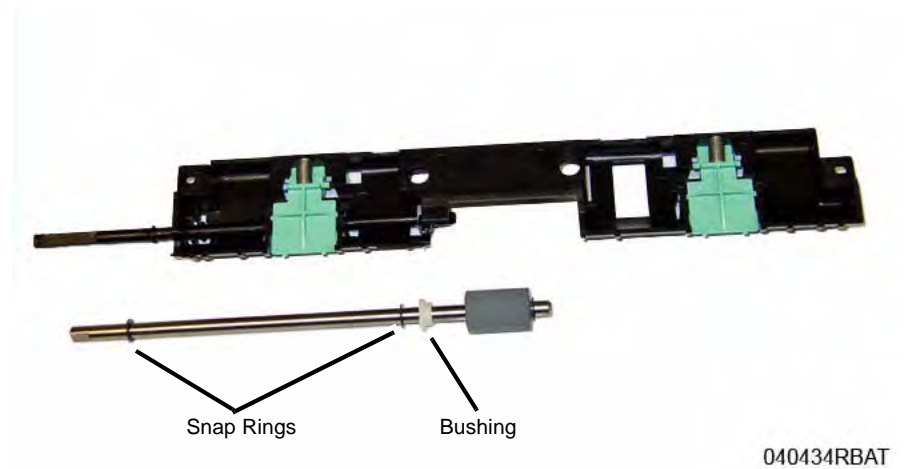

**Figure 10 Drive Roll**

## Replacement

**NOTE:** Tapered Plastic Screws and Round Machine Screws are used to hold the cover to the frame. Make sure that the Plastic Screws go into plastic components and Machine Screws go into the metal frame.

Install the components in the reverse of removal.

1. When replacing the Drive Roll in the Feed Assembly lower half make sure the flat on the bushing aligns with the flat on the assembly
2. After installing the Feed Assembly upper half; install the Feed Assembly bottom screws (2) first, and route the wires through the frame (Figure 6).

## REP 1.26 Registration Roll

### Parts List on PL 4.4

### Removal

1. Switch Off the Printer and unplug the Power Cord.
2. Remove the following covers:
  - a. The Front Cover (REP 1.1).
  - b. The Top Cover (REP 1.3).
3. Remove the Bottom Bar and Duplex Assembly (Figure 1).
  - a. Remove the screws (2) and the Bottom Bar.
  - b. Press the Green Tabs (2) to unlatch the Duplex Assembly. Remove the Duplex Assembly through the rear of the printer.

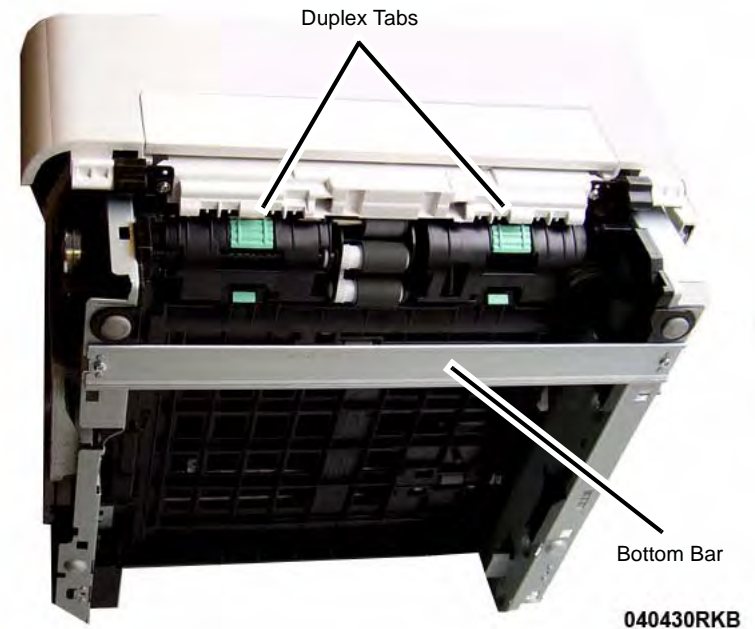
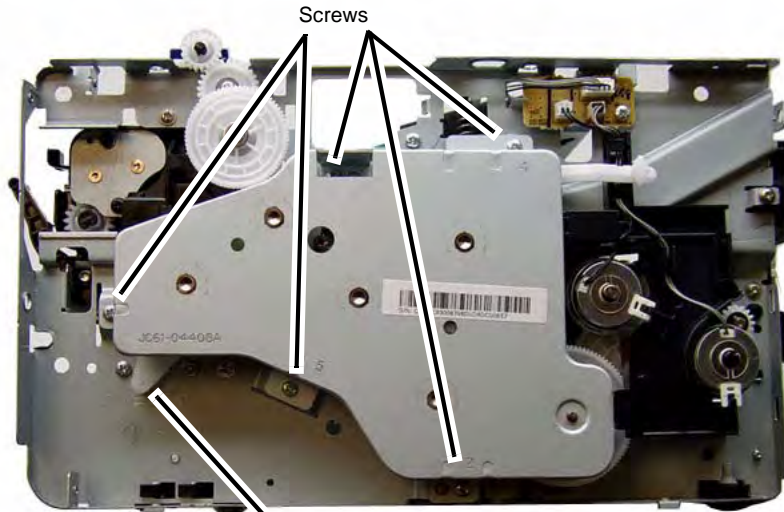

Figure 1 Bottom Bar and Duplex Assembly (Bottom View)

4. Remove the Fuser Module (REP 1.17).

5. Remove the Main Drive Unit (5 screws) and move the Fuser Drive Locking Lever to the Unlock position (Right) (Figure 2).



Locking Lever

**Figure 2 Main Drive Unit**

040445RKB

6. Perform the Following (Figure 3):
  - a. Disconnect the paper Feed PWB Connector (CN3), and remove the PWB (1 screw).
  - b. Remove the Feed and Registration Clutches, remove the Snap Rings and Washer from the Clutches.
  - c. Remove the Feed and Registration Clutch Assembly and the PWB, release the latches (2).

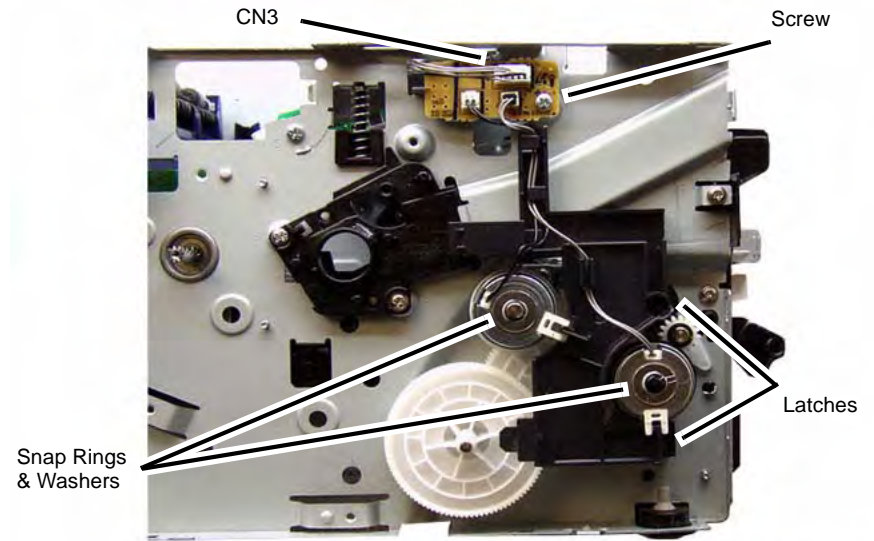

Snap Rings & Washers

040446RKB

**Figure 3 Feed and Registration Clutch / Paper Feed PWB**

7. Remove the Feed and Registration Clutch Drive Gears (Figure 4).

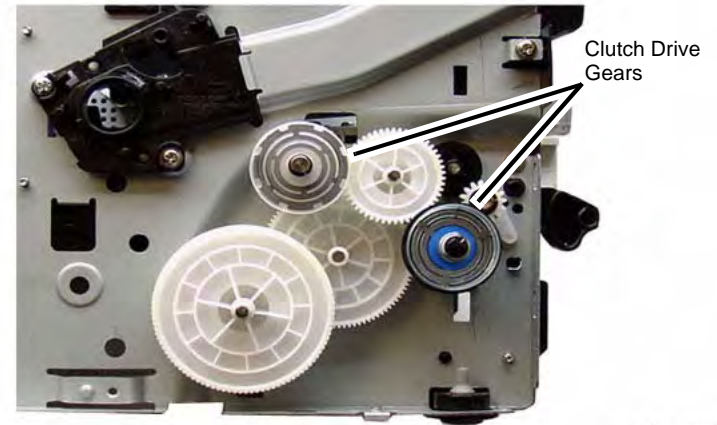

Clutch Drive Gears

040447RKB

**Figure 4 Feed and Registration Clutch Drive Gears**

8. Remove the following (Figure 5):  
 Make note of the order that the Feed and Registration Drive Gears are removed in so they can be re-installed correctly.
  - a. Feed and Registration Drive Gears, there is a Snap Ring on one gear.
  - b. Feed and Registration Clutch Bushings (2 Snap Rings).
  - c. Shaft Bushings (2), release the latches.

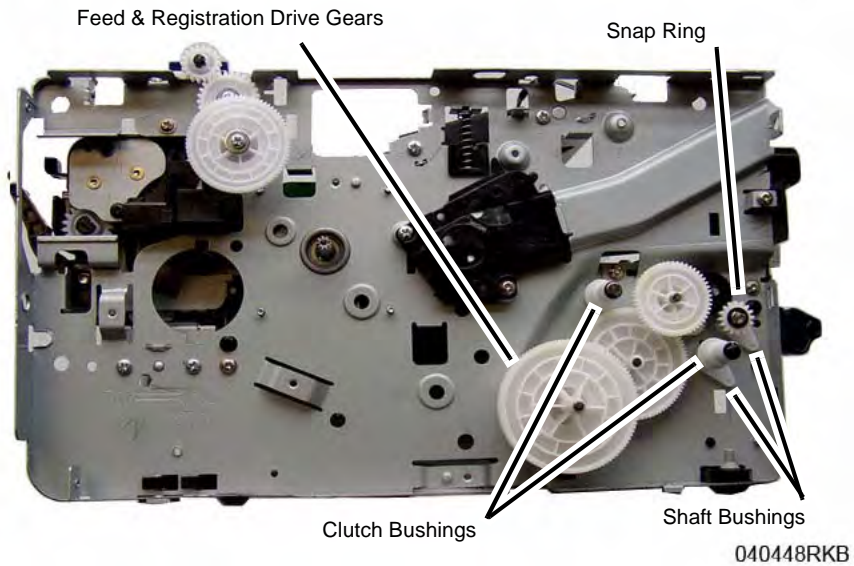

**Figure 5 Drive Gears and Bushings**

9. On the Bottom of the printer, remove the Feed and Registration Sensor PWB Cover (Figure 6).
  - a. Remove the screw (1).
  - b. Release the Latch and remove the cover.

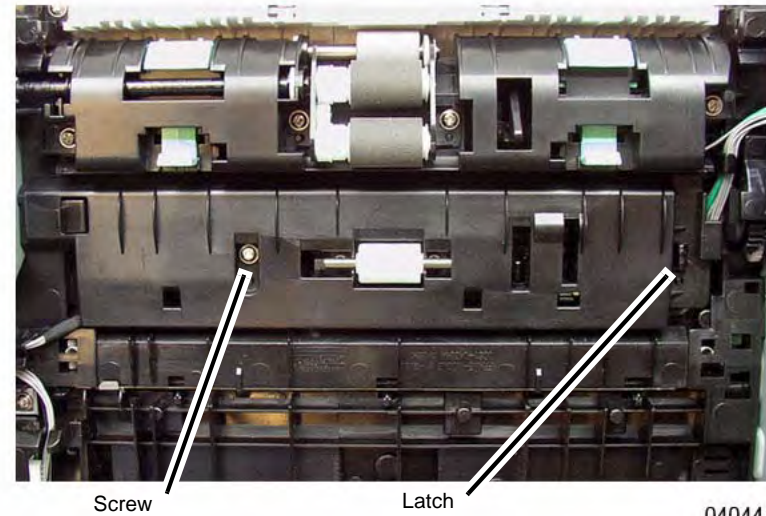

**Figure 6 Feed and Reg Sensors PWB Cover (Bottom View)**

10. Removing the Feed Sensor Actuator, release the actuator from the latch (Figure 7):  
 Note the location of the Spring in the frame cutout for reinstallation.

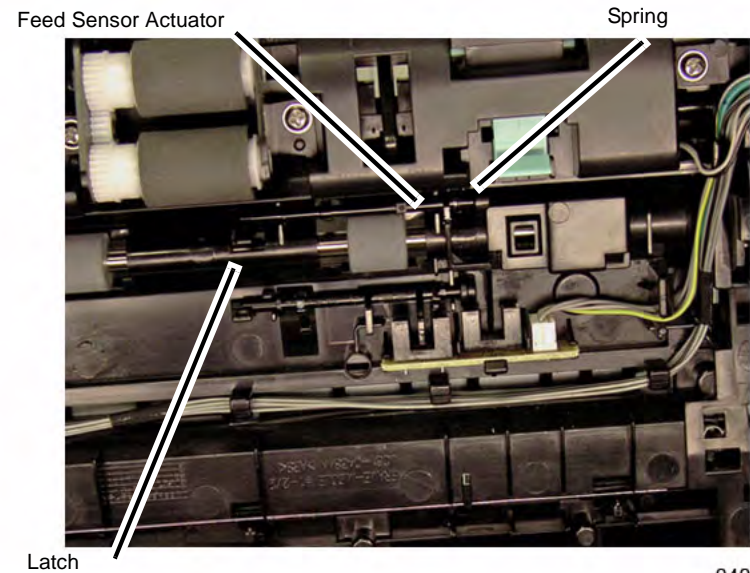

**Figure 7 Feed Sensor Actuator (Bottom View)**

11. On the bottom of the Printer (Figure 8):
- Disconnect the Drive Motor Connector.
  - Remove the ground screw (1).

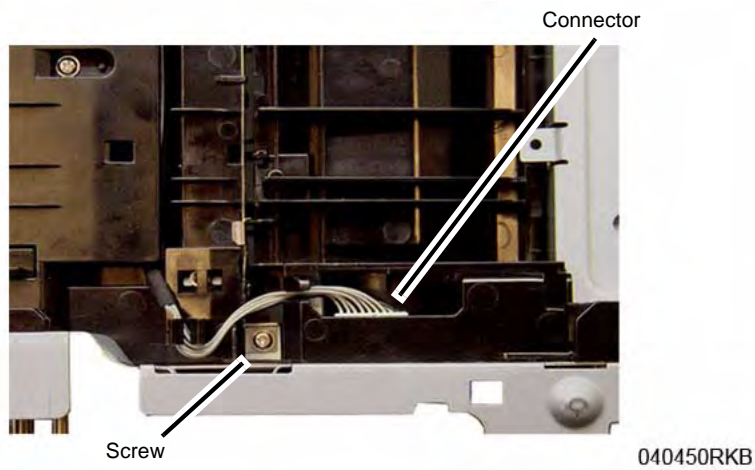

Figure 8 Drive Motor Connector & Screw (Bottom View)

12. Remove the PWB's (3), disconnect the connectors (Figure 9):
- The HVPS PWB (6 screws), and remove the Spring Contacts (4) from the high voltage contact guide.
  - Remove the LVPS PWB (6 screws), and the insulation (black) pad behind the PWB.
  - Remove the Main PWB (5 screws)

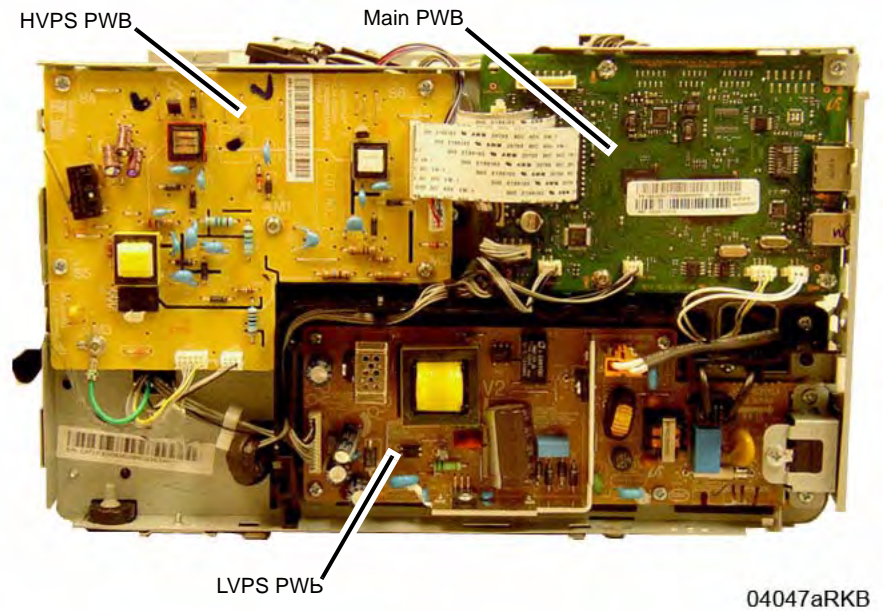
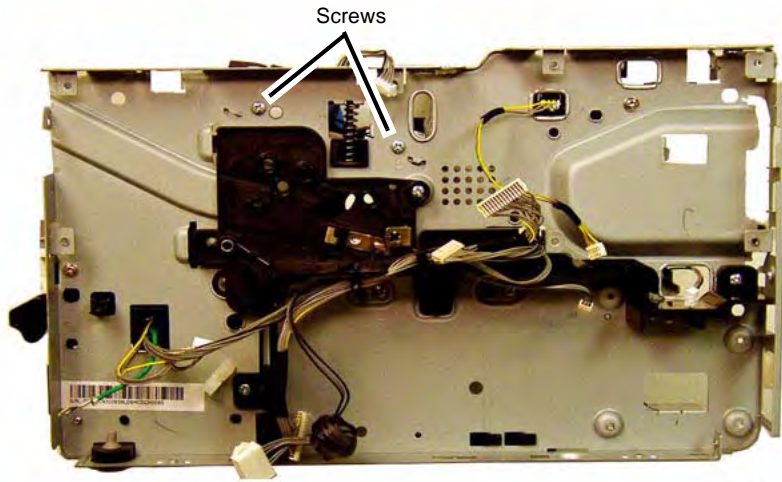

Figure 9 PWB Removal

13. Remove the LSU Assembly (4 screws), 2 on each side of the printer (Figure 10, Figure 11).



040443RBAT

Figure 10 LSU Left Side Screws

14. Remove the following (Figure 12):  
Wire harness guide (2 screws).  
High voltage contact guide (2 screws).

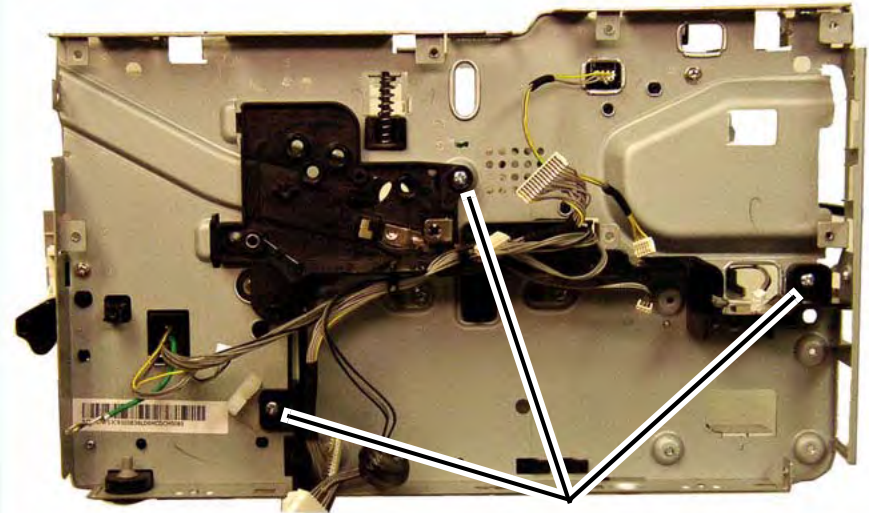

040445RBAT

Figure 12 Wire Guides and HV Contact Guide

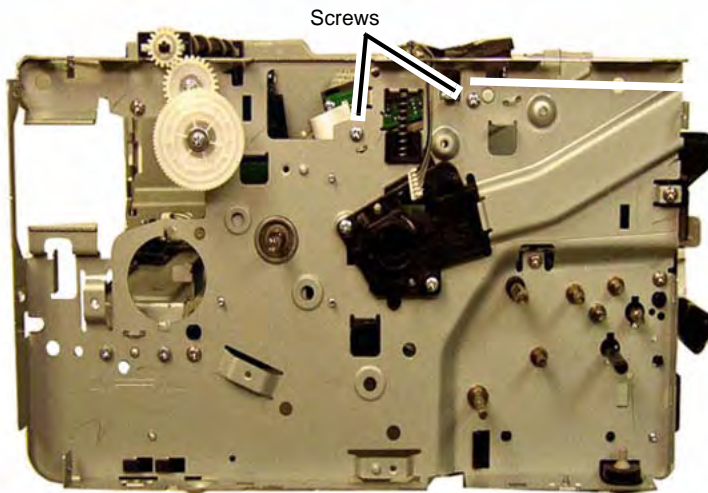

040444RBAT

Figure 11 LSU Right Side Screws

15. Remove the Exit Sensor Plate screws (2) from the Right Frame (Figure 13).

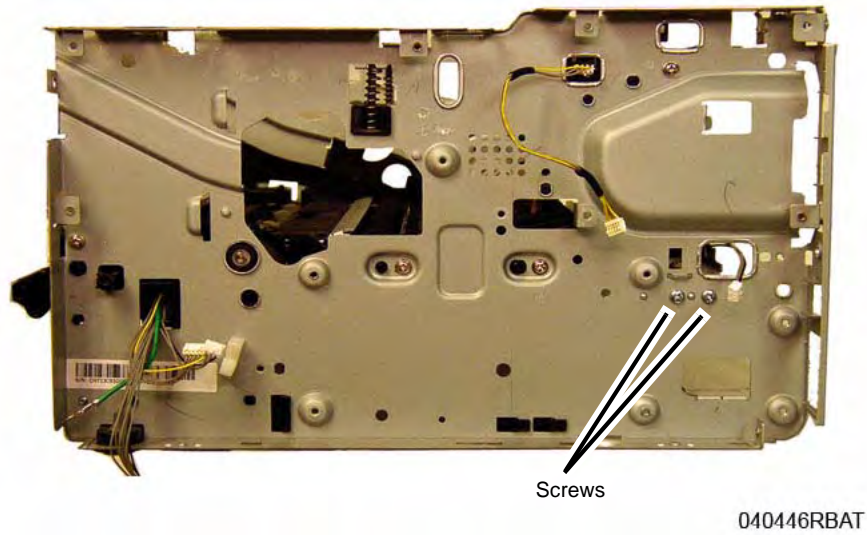

Figure 13 Exit Sensor Plate Screws

16. Remove the Right Frame Paper Path screws (3) and the Exit Assembly screw (2) (Figure 14).

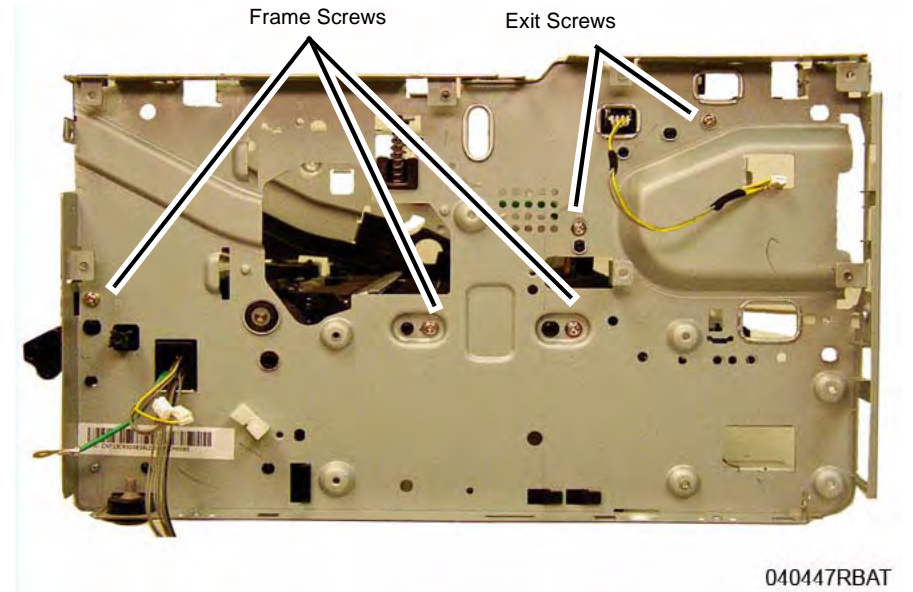

Figure 14 Right Frame Screws Removal



17. Remove the Left Frame Paper Path screws (3) (Figure 15).

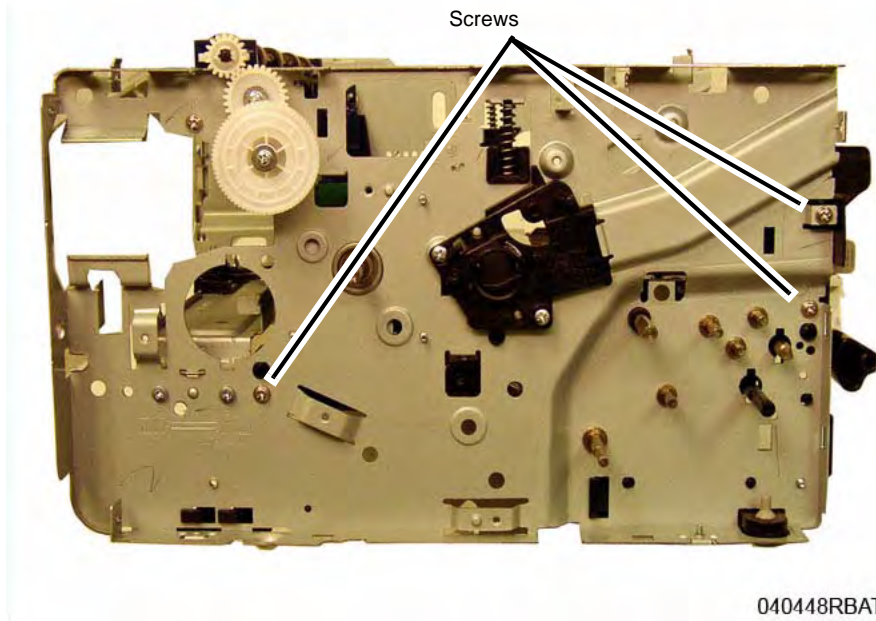

Figure 15 Left Frame Screw Removal

18. Separate the Left and Right Frames from the Paper Path Frame, route the wires through the frames as needed.

19. Remove the Reg Roll Drive Pivot Gears from the Paper Path Frame (Figure 16).

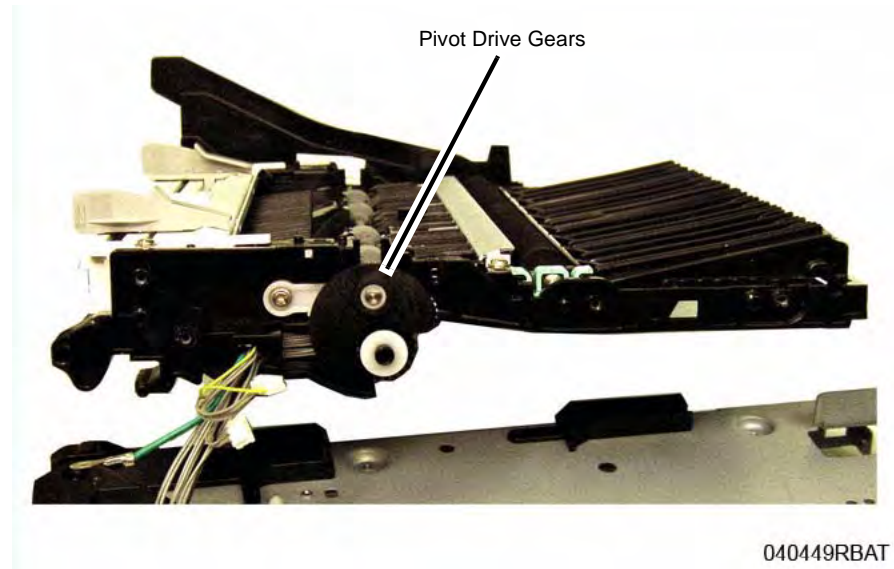

Figure 16 Registration Roll Drive Pivot Gears

20. Remove the Reg Roll Drive Gear and Bushing (1 screw) (Figure 17).

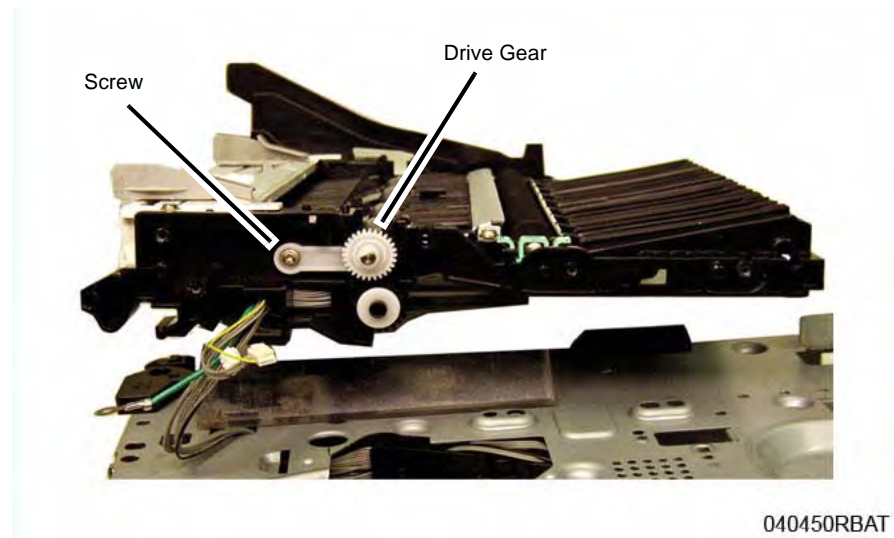

Figure 17 Registration Roll Drive Gear and Bushing

21. Remove the Reg Roll from the Paper Path Frame (Figure 18).  
Note the location of the Bushing in the frame for reinstallation.

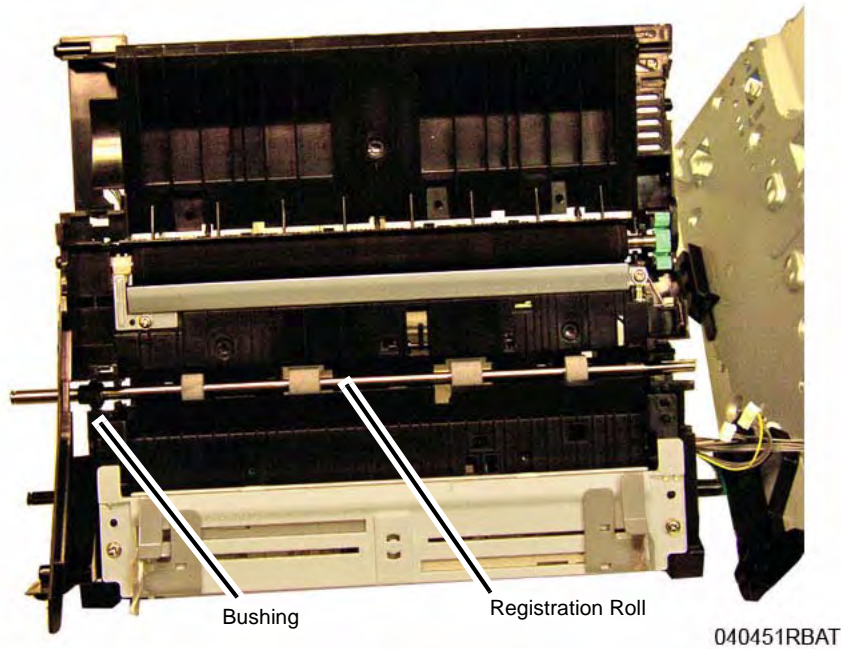

Figure 18 Registration Roll Removal

22. Remove the Bushing and E-ring from the Reg Roll (Figure 19).

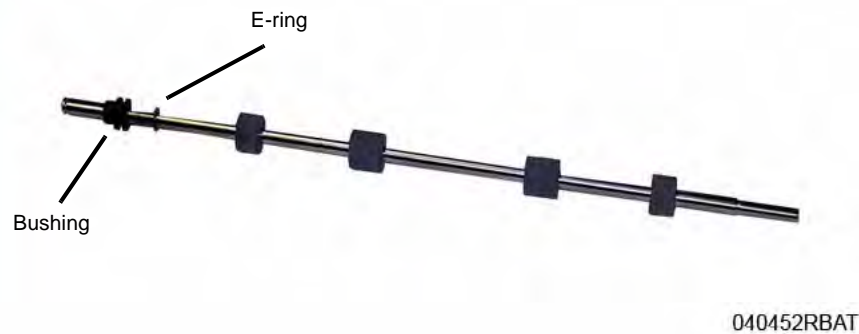

Figure 19 Registration Roll

## Replacement

**NOTE:** Tapered Plastic Screws and Round Machine Screws are used to hold the parts to the frame. Make sure that the Plastic Screws go into plastic components and Machine Screws go into the metal frame.

Install the components in the reverse of removal.

**NOTE:** The Frame is flexible and can be bowed out if the screws are not tightened in the correct order.

Reinstall the Frame as follows so it seats flush against the printer internal modules.

1. After aligning the left and right frames together with the inside modules; install, but do not tighten, the Paper Path Frame screws, (3) on the Left and Right Side Frame to hold the printer together.  
Refer to (Figure 14) and (Figure 15).
2. On the bottom of the printer, refer to (Figure 8):
  - a. Install the ground screw (1).
  - b. Connect the Printer Drive Motor Connector.
3. Tighten the Paper Path Frame screws installed in Step 1.
4. Continue with the parts replacement.
  - a. When installing the Paper Feed Sensor Actuator made sure the spring is seated in the frame cutout, refer to (Figure 7).
  - b. When installing the Feed and Registration Drive Gears, and Snap Ring, refer to (Figure 20) for correct installation the Feed and Registration Drive Gears.

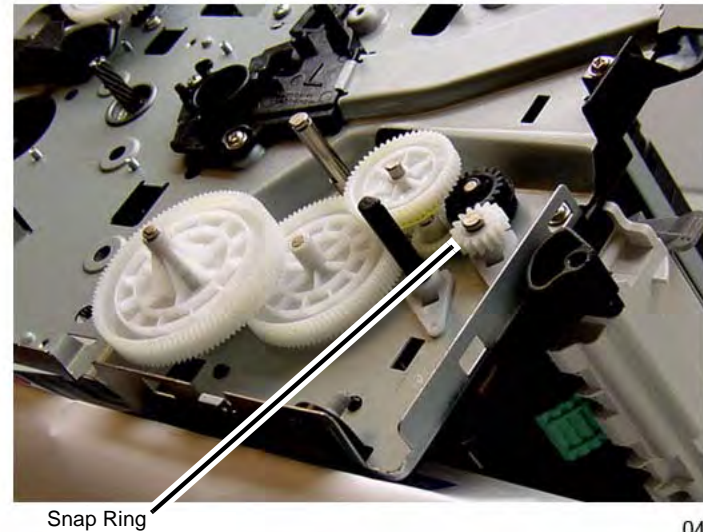
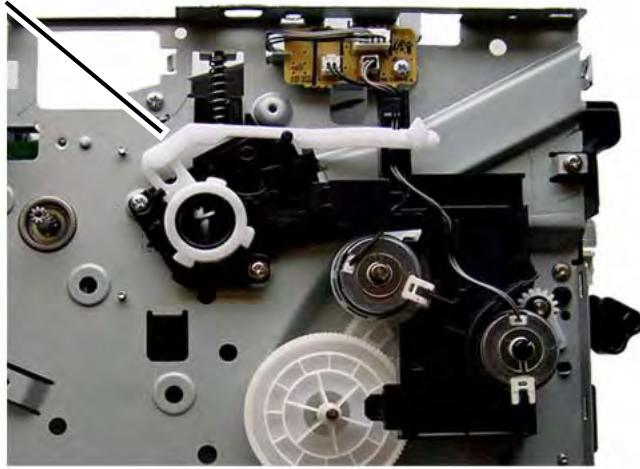

Figure 20 Feed and Registration Drive Gears

- c. When installing the Front Cover Support Arm make sure it is correctly placed on the Stop Bracket (Figure 21).

Support Arm



040443RKB

Figure 21 Front Cover Support Arm Placement

## REP 1.27 Manual Feed Cover

### Parts List on PL 2.1

#### Removal

1. Remove the Manual Feed Cover, release it from the pivots (2) (Figure 1).



Pivots

Tag Matrix

TagMatrix-BAT-KB

Figure 1 Manual Feed Cover (Top View)

#### Replacement

1. **IMPORTANT:**

If the Manual Feed Cover is being replaced, remove the Tag Matrix from the old cover and install it on to the new Manual Feed Cover (Figure 1).

Install the components in the reverse of removal.



**Main**  
PL 1.1 Main ..... 5-3

**Covers**  
PL 2.1 Covers ..... 5-4

**Top Cover**  
PL 3.1 Top Cover ..... 5-5

**Frame**  
PL 4.1 Frame ..... 5-6

**Duplex**  
PL 4.2 Duplex Assembly ..... 5-7

**Exit Frame**  
PL 4.3 Exit Frame ..... 5-8

**Paper Path**  
PL 4.4 Paper Path ..... 5-9

**Frame Base Pick - Up**  
PL 4.5 Frame Base Pick - Up ..... 5-10

**Left Main Frame**  
PL 4.6 Left Main Frame ..... 5-11

**Right Main Frame**  
PL 4.7 Right Main Frame ..... 5-12

**Fuser**  
PL 5.1 Fuser ..... 5-13

**Lower Fuser**  
PL 5.2 Lower Fuser ..... 5-14

**Paper Tray**  
PL 6.1 Paper Tray ..... 5-15  
Part Number Index ..... 5-16



## PL 1.1 Main

Item	Part	Description
1	–	Fuser (PL 5.1)
2	–	Paper Tray (PL 6.1)
3	–	Top Cover (PL 3.1)
4	–	Rear Cover (PL 2.1)
5	–	Coupling B Lever
6	–	Frame
7	140N63706	MAIN PWB -3052 NI (NW / Wifi) (DMO W / NA)
–	140N63707	MAIN PWB -3052 NI (NW / Wifi) (DMO E / Russia/Middle East/ South Africa)
–	140N63712	MAIN PWB 3260 DNI (Chile)
–	140N63708	MAIN PWB 3260 DI (Dup / Wifi) (DMO W / NA)
–	140N63709	MAIN PWB 3260 DI (Dup / Wifi) (DMO E / Russia/Middle East)
–	140N63710	MAIN PWB 3260 DNI (Dup / NW / Wifi) (DMO W / NA)
–	140N63711	MAIN PWB 3260 DNI (Dup / NW / Wifi) (DMO E / Russia/Middle East/ South Africa/Argentina/Peru)
–	140N63713	MAIN PWB 3260 DN (Russia)
8	140N63727	WNPC (WIFI) PWB

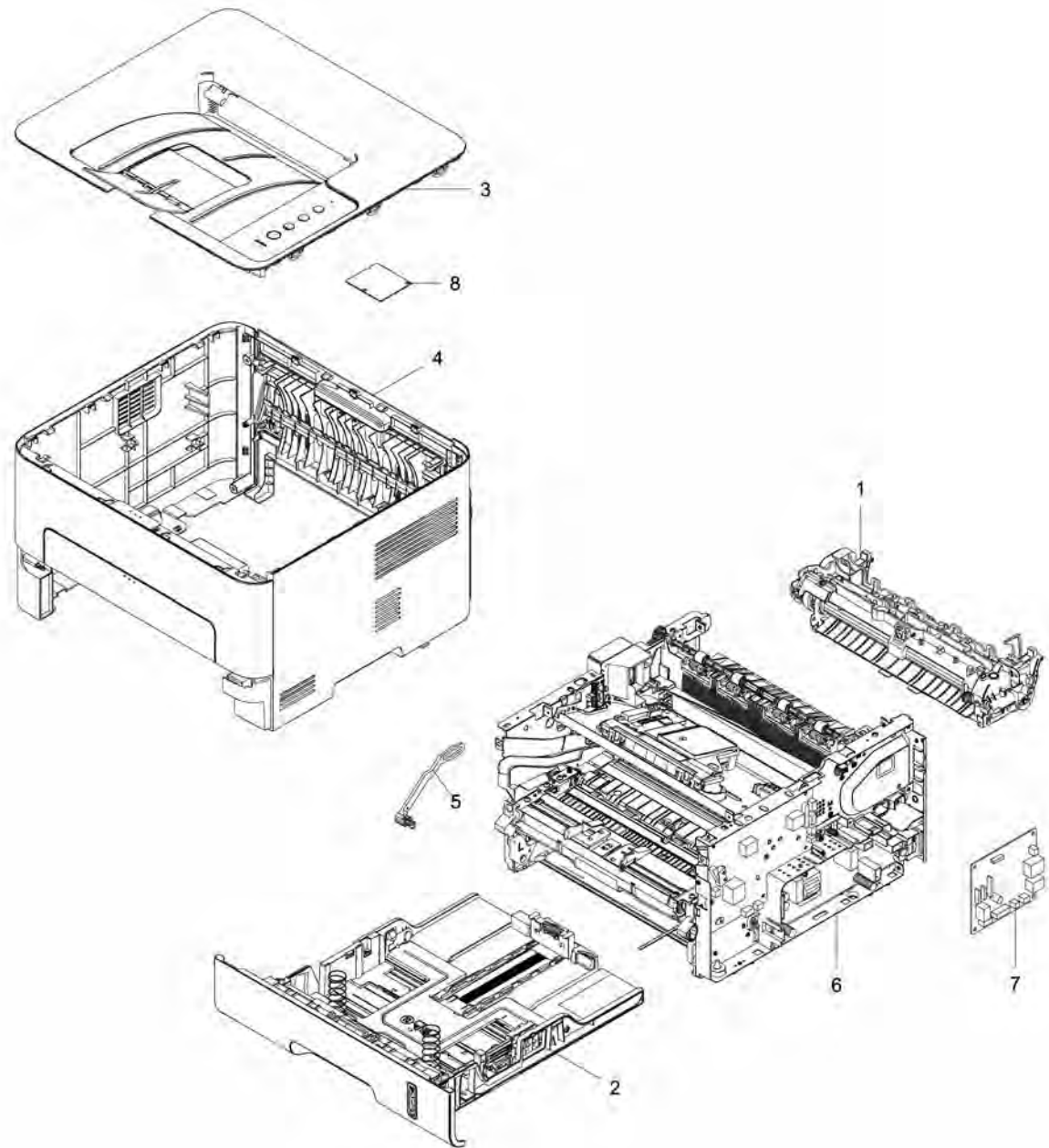

## PL 2.1 Covers

Item	Part	Description
1	002N03167	Left Cover
2	002N03182	Right Cover
3	002N03172	Rear Cover Assembly
4	002N03175	Front Cover Assembly
5	-	Rear Cover
6	-	Exit Paper Guide
7	-	Duplex Gate
8	-	Spring
9	-	Front Cover Latched Sensor
10	-	CRUM PWB
11	-	CRUM Contacts
12	-	Front Cover
13	-	Manual Cover
14	-	Front Harness Cover
15	-	CRUM Harness

3 { 5-8  
4 { 9-14

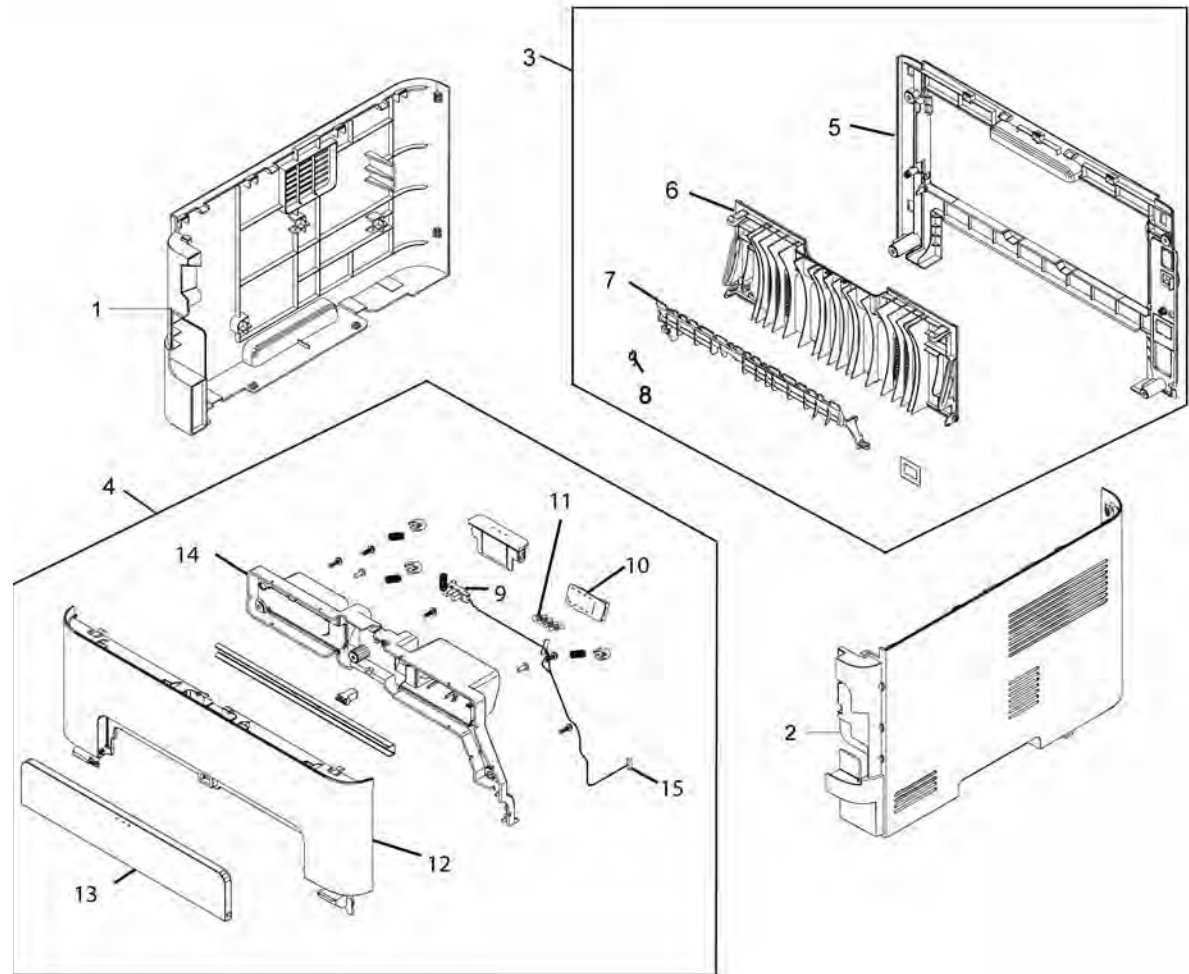



## PL 3.1 Top Cover

Item	Part	Description
1	–	Output Support
2	–	Top Cover
3	–	Antistatic Brush
4	–	Paper Stacker
5	–	Bin Full Sensor Actuator
6	–	Spring
7	–	Exit Cover
8	140N63723	Control Panel PWB
9	–	Key Holder
10	–	Holder
11	002N03187	Top Cover Assembly

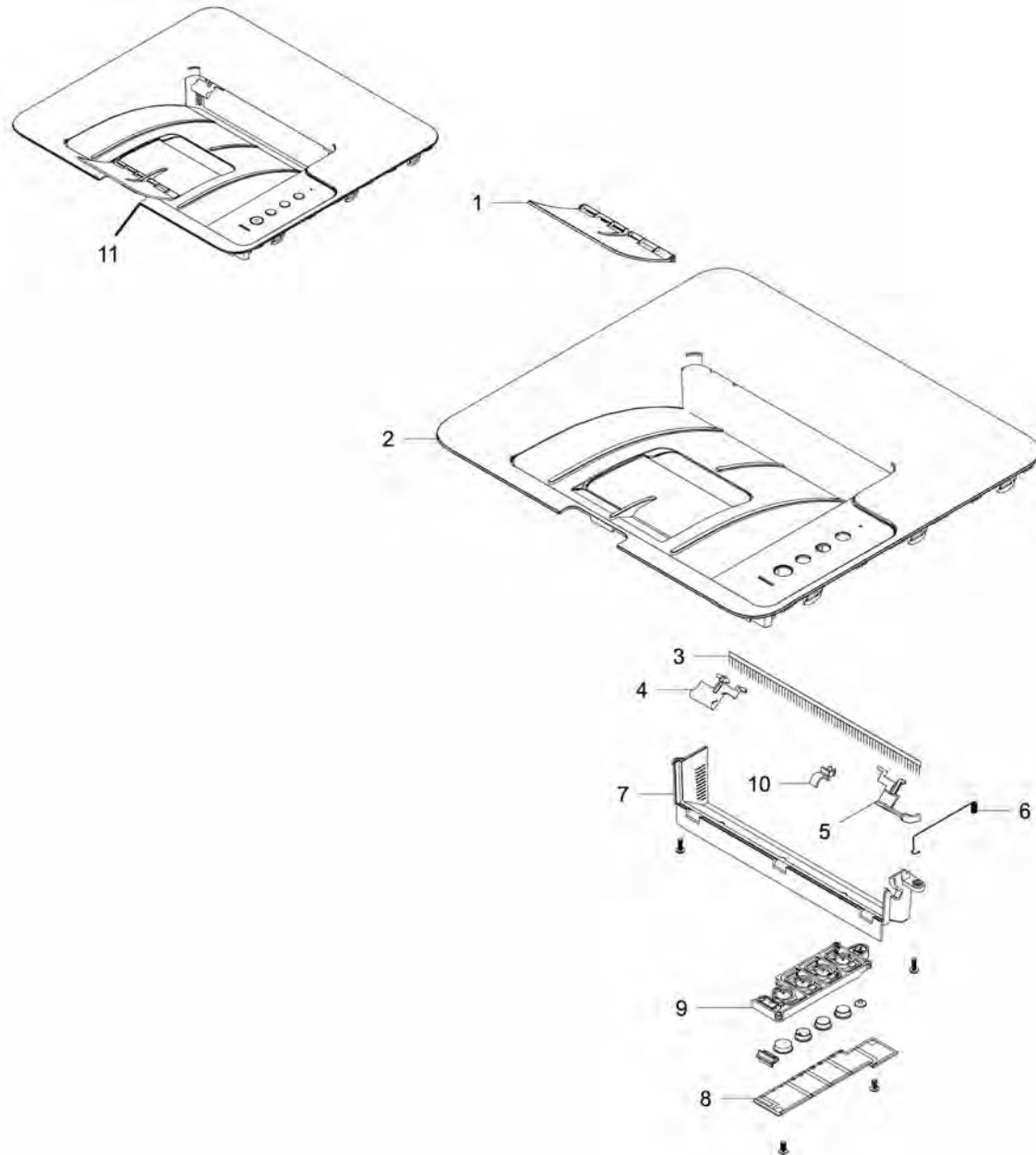

## PL 4.1 Frame

Item	Part	Description
1	117N01969	Flat Cable
2	105N02301	HVPS
3	105N02300	LVPS 220V
–	105N02299	LVPS 110V
4	121N01247	Registration Clutch
5	121N01248	Feed Clutch
6	–	TR Holder
7	–	Bottom Bar
8	–	Ground Clip
9	022N02803	Transfer Roller
10	–	Exit Gear
11	–	Feed Gear
12	–	Exit Idle Gear
13	–	RDCN Exit Gear
14	011N00581	Paper Feed PWB
15	–	Main Exit Frame
16	–	Paper Path Frame
17	–	Fuser Plate Frame
18	–	LSU Bracket Frame
19	–	Left Main Frame
20	–	Right Main Frame
21	062N00292	LSU
22	130N01758	Exit Sensor

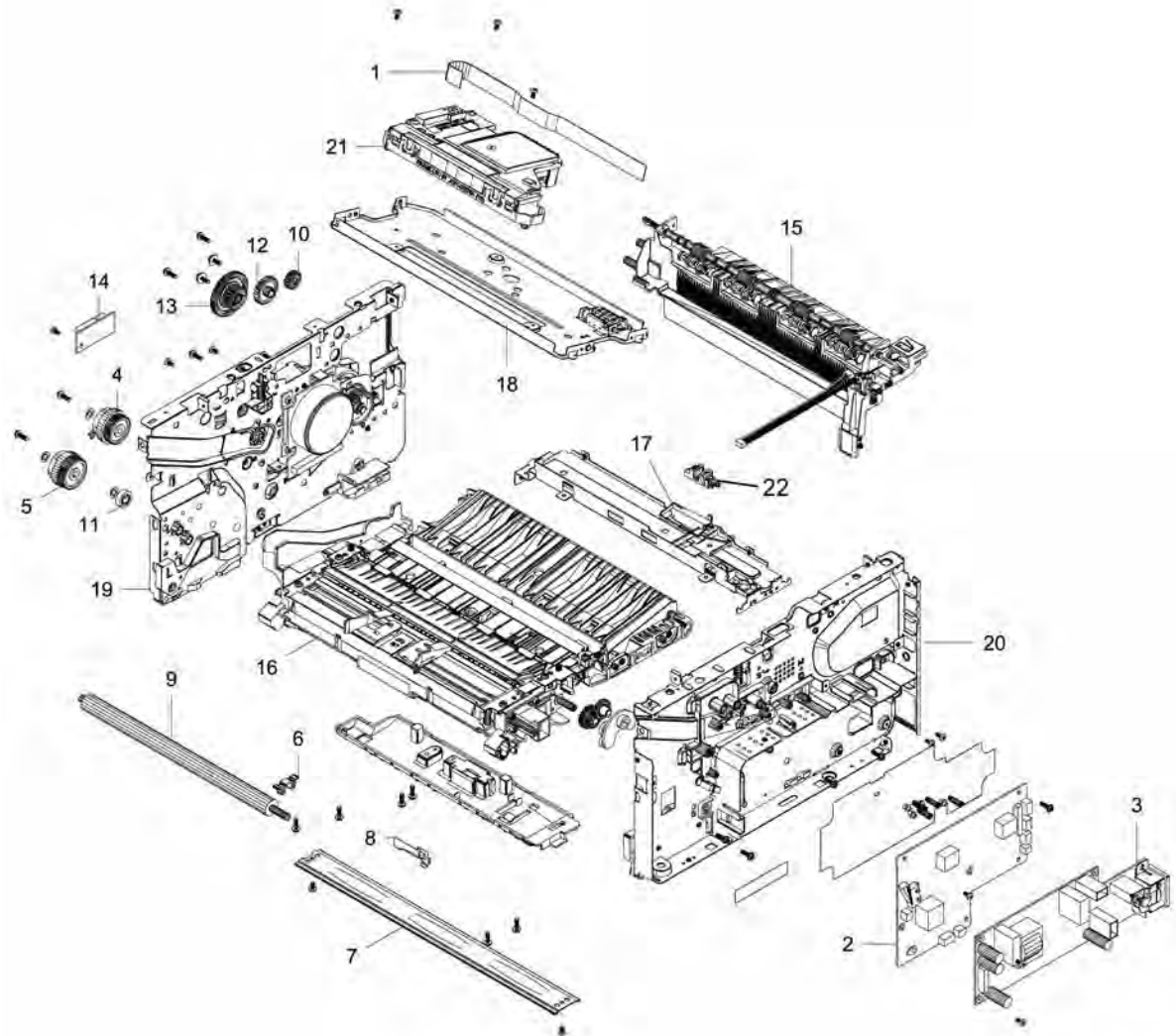

## PL 4.2 Duplex Assembly

Item	Part	Description
1	-	M Idle Roller
2	-	Washer
3	-	Idle Roll Shaft
4	-	Spring
5	-	Duplex Upper Guide
6	-	Duplex Paper Guide
7	-	Duplex Align Bracket
8	-	Ground Terminal
9	-	Roller Bushing
10	-	Rubber Feed Roller
11	-	Feed Shaft
12	-	Pulley
13	-	Exit Gear
14	-	Flat Rubber Belt
15	-	Feed Roller
16	-	Duplex Base Frame
17	-	Duplex Latch
18	022N02795	Duplex Assembly - (A4) (DMO-E / Russia/Middle East/South Africa/ Argentina/Peru)
-	022N02796	Duplex Assembly - (Letter) (DMO-W / NA / Chile)

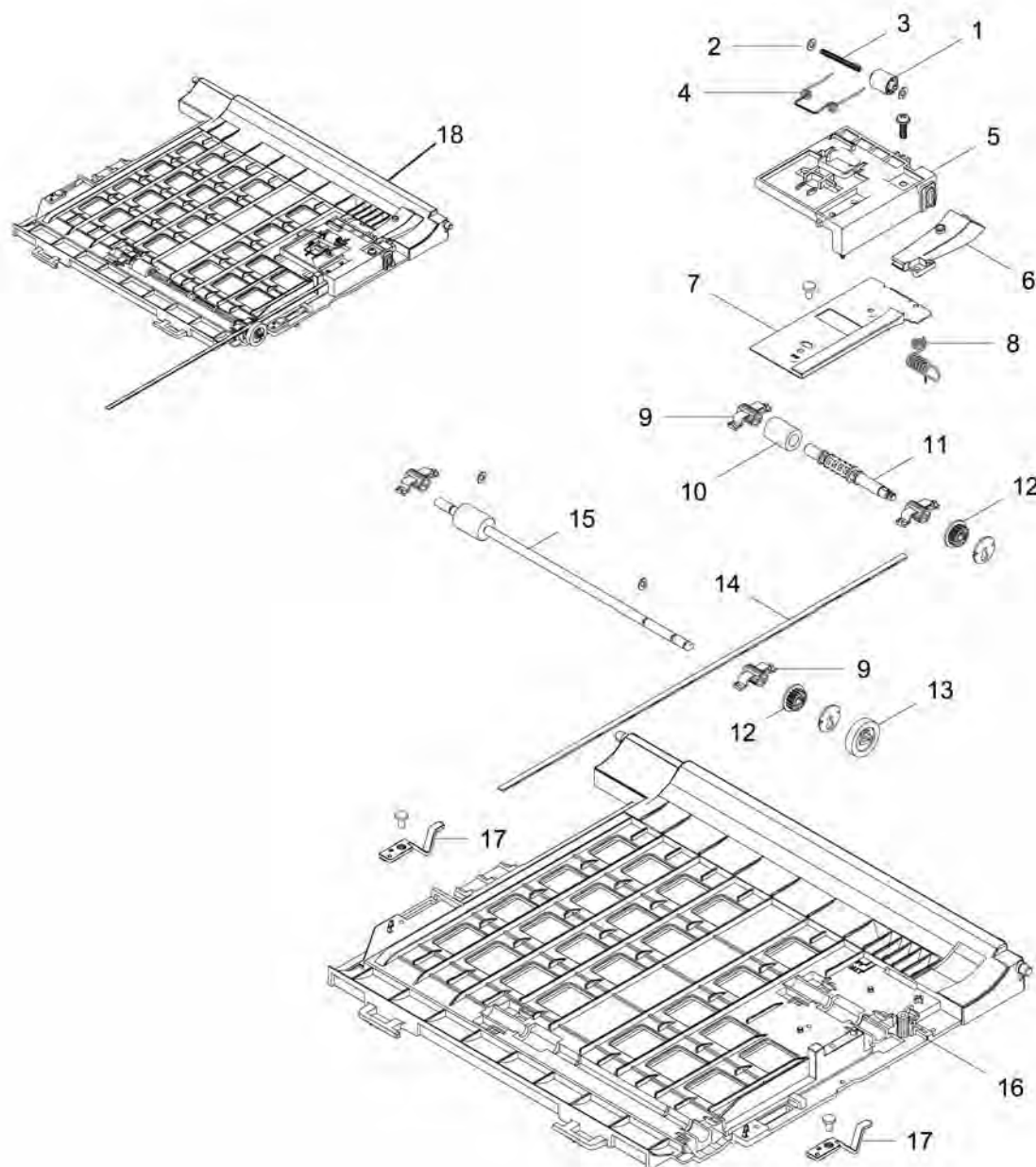

## PL 4.3 Exit Frame

Item	Part	Description
1	130N01758	Output Tray Full Sensor
2	-	Harness
3	006N01361	Bushing
4	-	Exit Frame
5	001N00546	Exit Roller
6	-	Decurler Roller
7	-	Exit Shaft
8	-	Rubber Exit Dup
9	-	Inner Exit Roller
10	-	Outer Exit Roller
11	-	Exit Roll Holder
12	-	Spring
13	-	Exit Frame Assembly

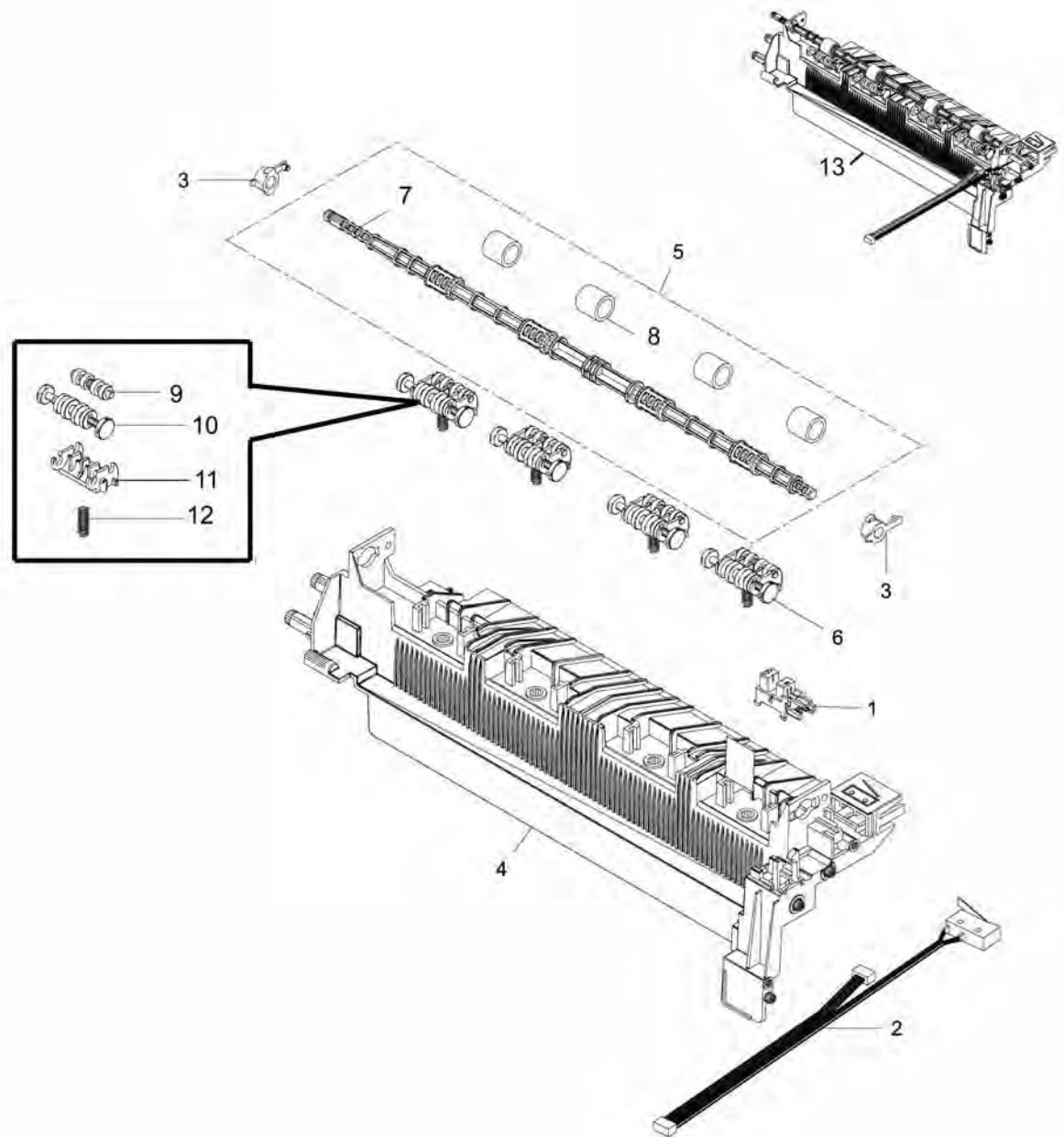



## PL 4.5 Frame Base Pick - Up

Item	Part	Description
1	-	Duplex Path Sheet
2	-	Duplex Guide
3	130N01758	Paper Tray Empty Sensor
4	-	Spring
5	-	Empty Actuator
6	-	Duplex Guide Lever
7	-	Pick Up Shaft
8	-	Pick Up Guide
9	022N02802	Paper Drive Roller
10	-	Bushing
11	130N01760	Paper Feed Roll Assembly
12	-	Feed Roll Holder
13	-	Idle Pick Up Gear
14	-	One Way Clutch
15	-	Retard Roller

11 { 12 - 15

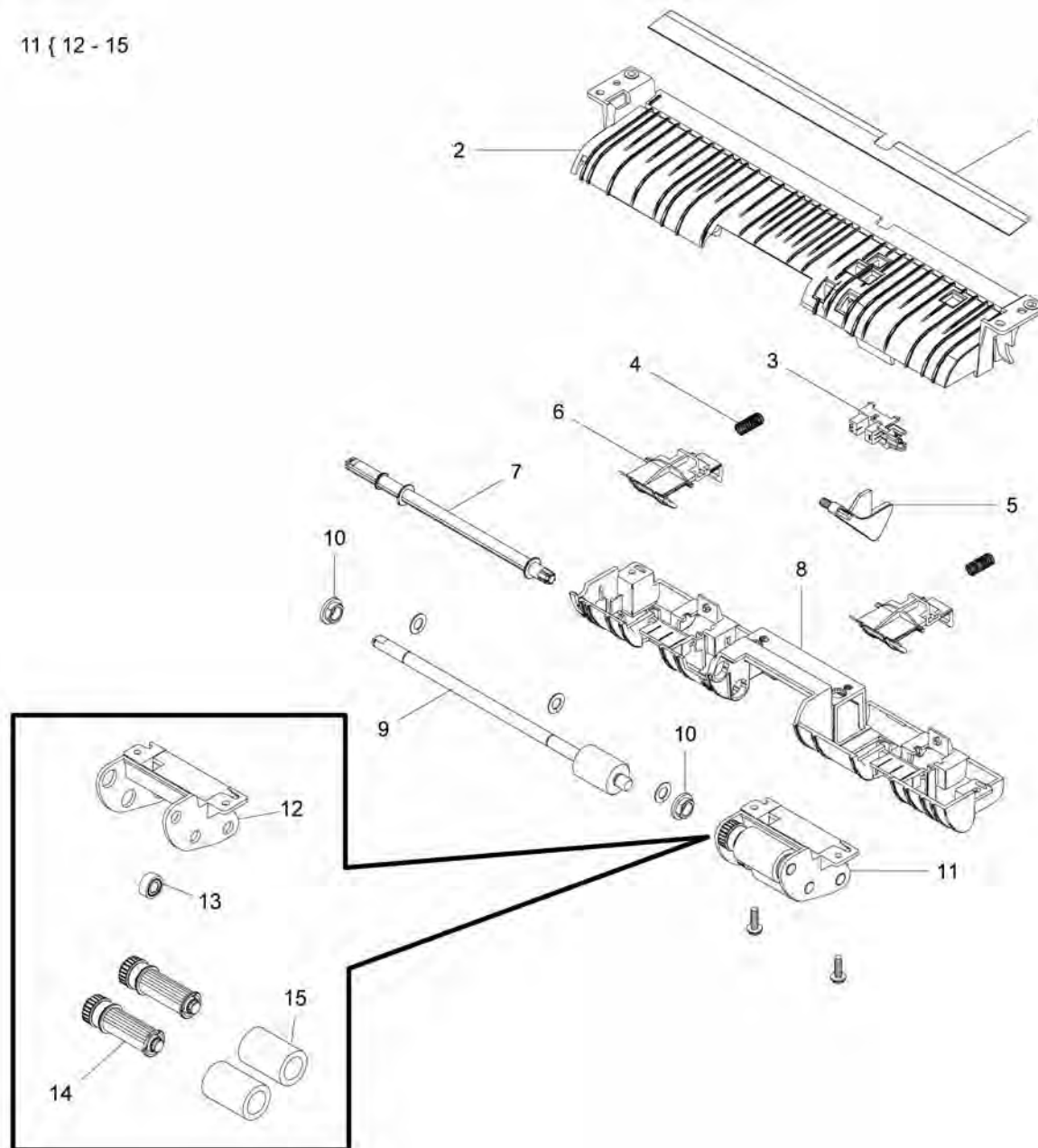

## PL 4.6 Left Main Frame

Item	Part	Description
1	—	Left Rear Guide
2	127N07865	Main Drive Motor
3	—	Fuser Drive Out Gear
4	—	Knock Up Left Guide
5	—	Left Developer Guide Plate
6	—	Left Frame
7	—	Shaft Bushing
8	007N01802	Paper Feed Idler Gear
9	—	Idler Gear
10	—	Band
11	—	Idler Gear
12	—	Fuser Locking Lever
13	—	Hub Clutch Gear
14	—	Feed Gear
15	—	Feed Gear 2
16	—	Cam Coupler
17	—	Coupling Lever
18	007N01803	Main Drive Unit
19	—	Harness Cover

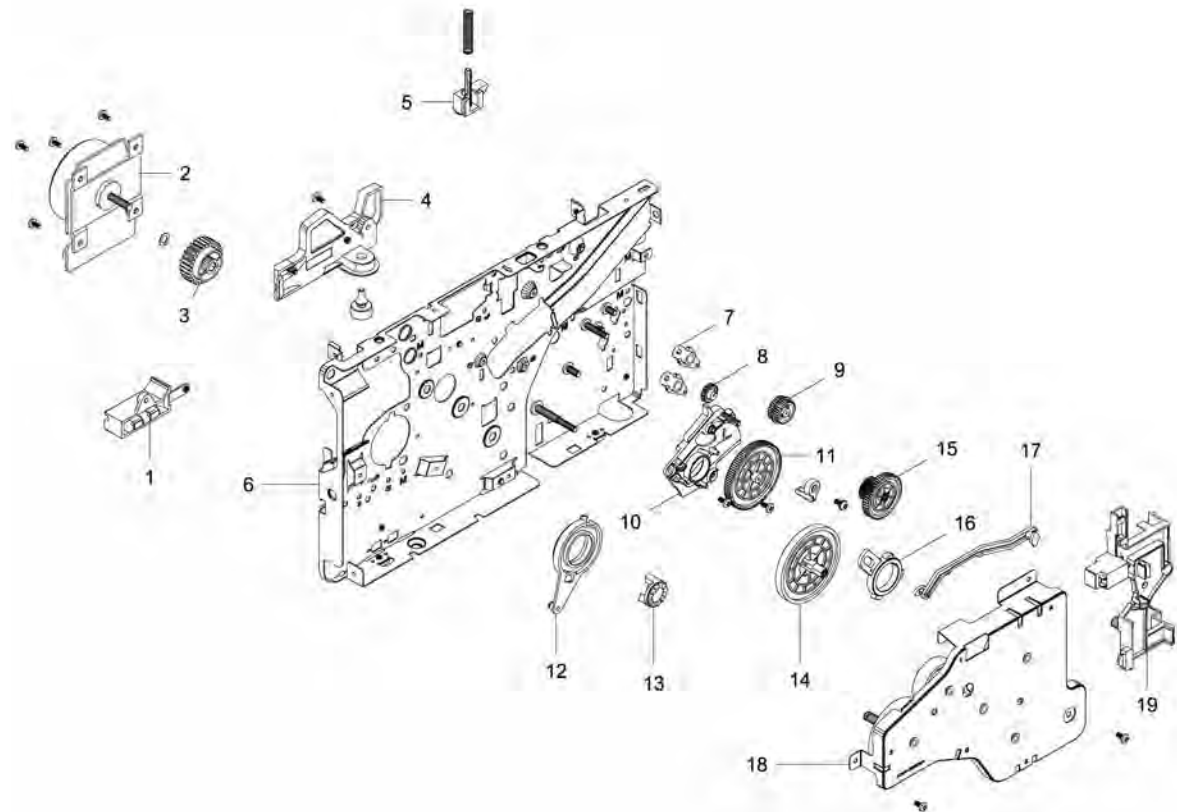

## PL 4.7 Right Main Frame

Item	Part	Description
1	–	Right Developer Guide Plate
2	–	CST Rear Guide
3	–	Lower Guide
4	–	Foot
5	–	Right Frame
6	–	Cable Clamp
7	–	LVPS Cover
8	–	Developer Right Guide
9	–	Spring
10	–	Ground Clip

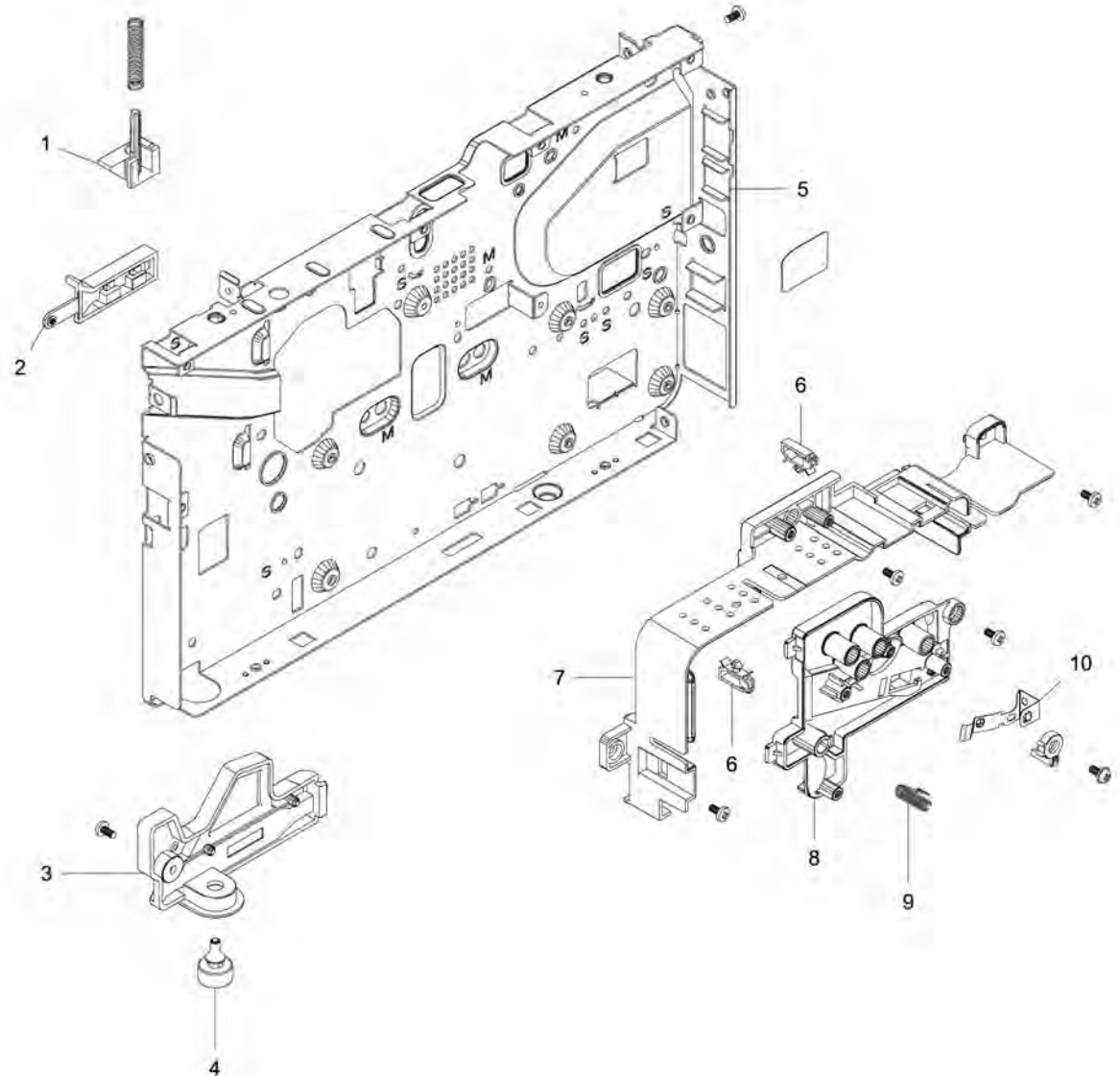



## PL 5.1 Fuser

Item	Part	Description
1	-	Upper Fuser
2	-	Fuser Lamp
3	-	Lower Fuser
4	-	Right Lamp Cap
5	-	Fuser Exit Drive
6	-	Left Lamp Cap
7	-	Fuser Gear Stopper
8	-	Fuser Rear
9	-	Fuser Joint Harness
10	-	Thermostat
11	-	Thermistor
12	-	Fuser Cover
13	-	Exit Roller
14	-	Spring
15	-	Guide
16	-	Spring
17	-	Exit Roller
18	-	Exit Shaft
19	-	Exit Gear
20	-	Bushing
21	-	Rear Guide
22	-	Exit Idle Roller
23	-	Spring
24	-	Actuator Holder
25	-	Exit Sensor Actuator
26	126N00430	Fuser Module (110V)
-	126N00431	Fuser Module (220V)

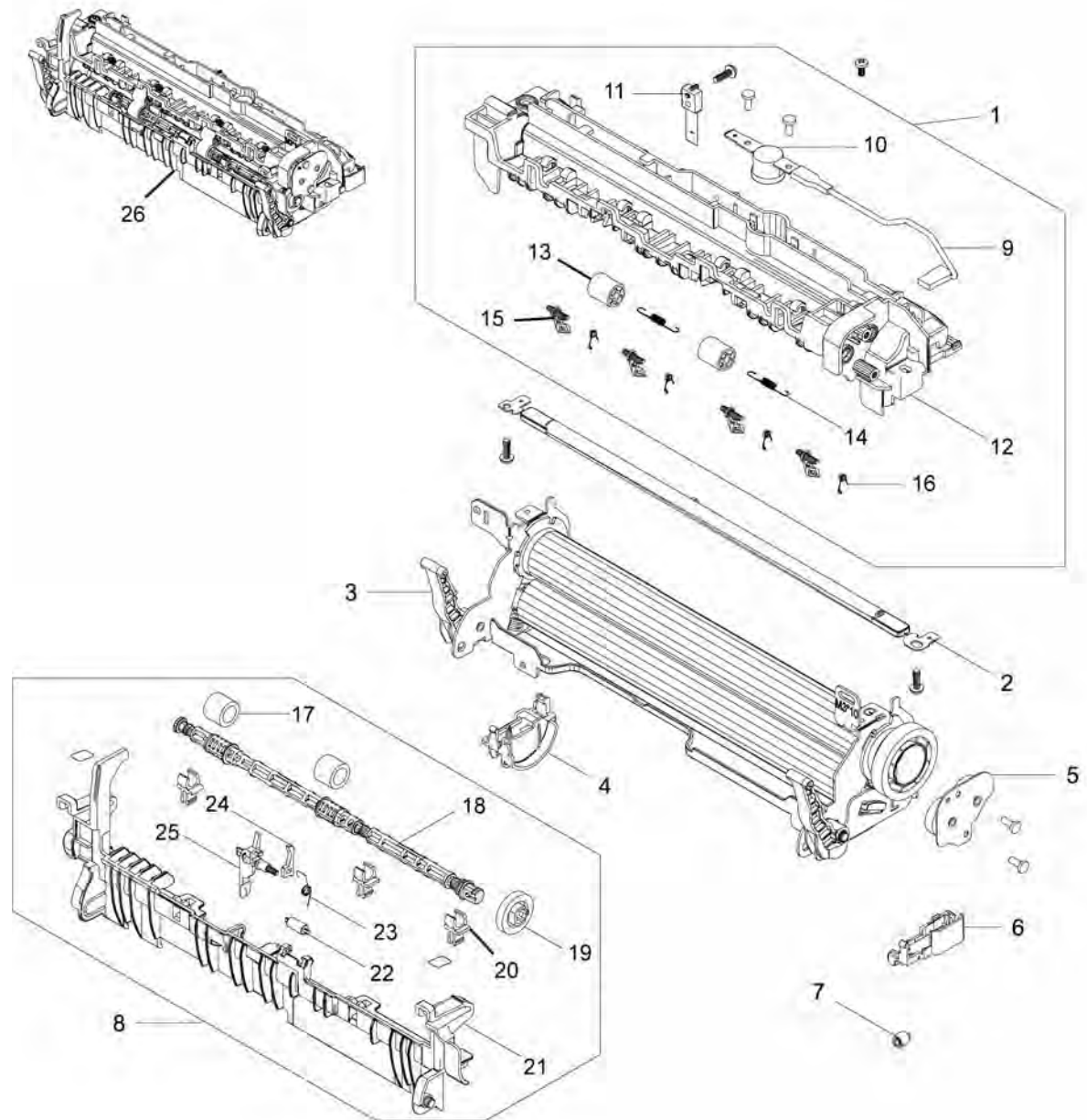

## PL 5.2 Lower Fuser

Item	Part	Description
1	—	Fuser Frame
2	—	Heat Roller
3	—	Left Bushing
4	—	Right Bushing
5	—	Gear
6	—	Roller
7	—	Spring
8	—	Bushing
9	—	Left Jam Lever Link
10	—	Antistatic Brush
11	—	Jam Lever
12	—	Right Jam Lever Link
13	—	Lower Fuser Assembly

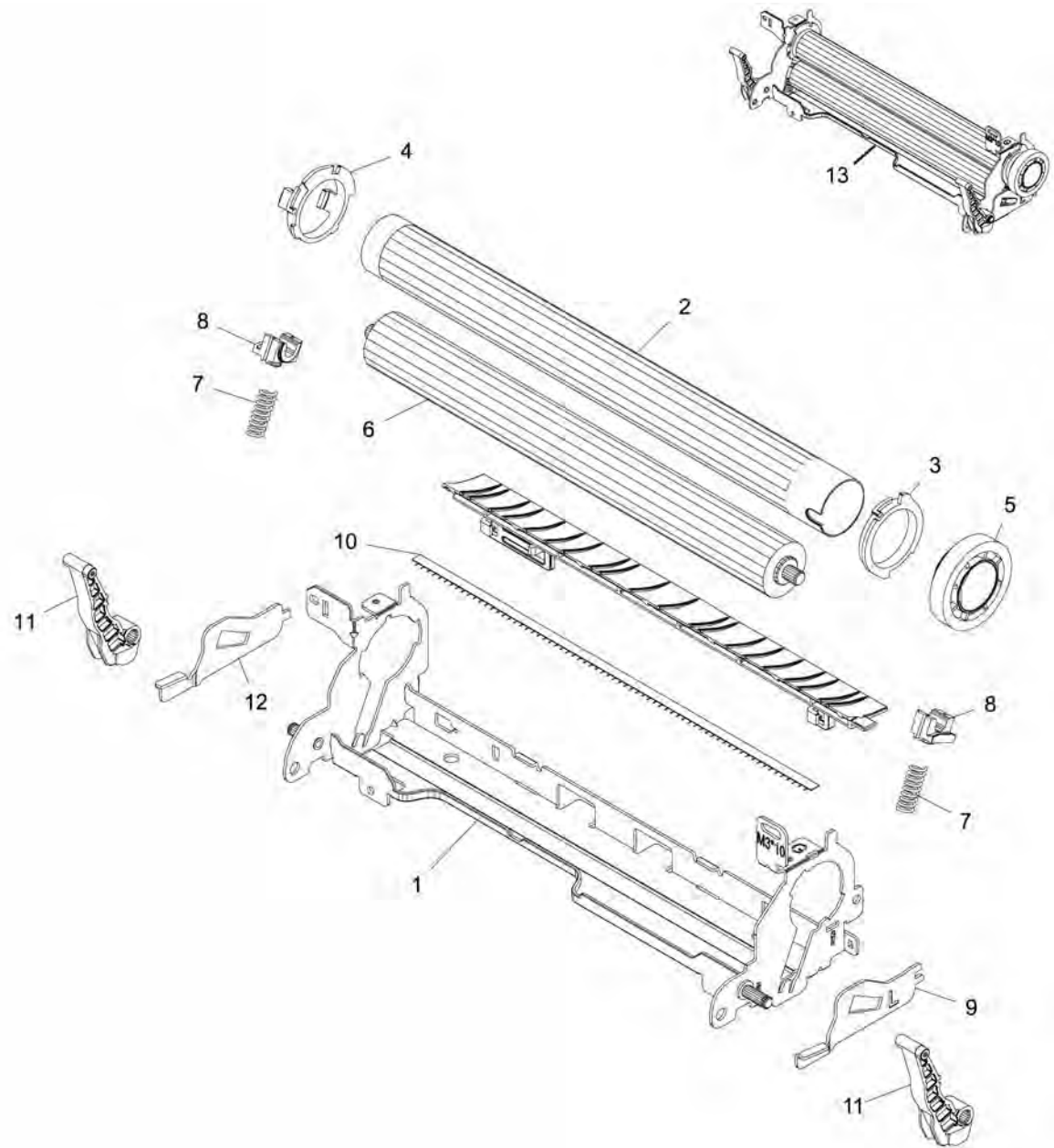

## PL 6.1 Paper Tray

Item	Part	Description
1	—	Lift Plate
2	—	Pad
3	—	Spring
4	—	Pinion Gear
5	—	Retard Roll Cover
6	050N00683	Retard Roll Assembly
7	—	Left Paper Guide
8	—	Left Plate
9	—	Spring
10	—	Paper Tray Latch
11	—	Spring
12	—	Right Paper Guide
13	—	Paper Tray Handle
14	—	Paper Tray Rear Guide
15	—	Paper Tray Frame
16	—	Paper Tray Handle
17	—	Paper Indicator
18	050N00682	Paper Tray

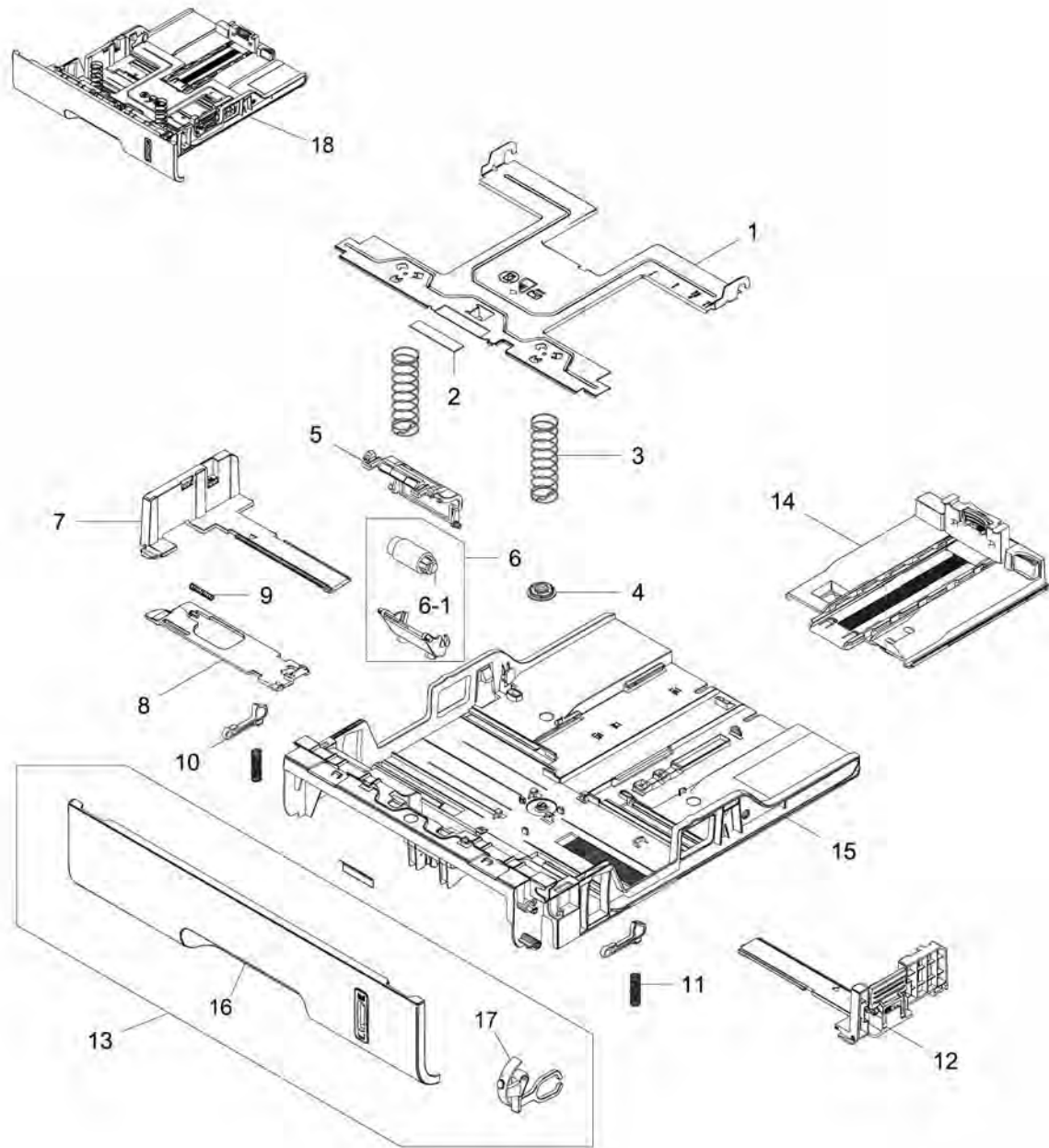

# Part Number Index

Table 1 Part Number Index

Part Number	Part List
001N00546	PL 4.3
002N03167	PL 2.1
002N03172	PL 2.1
002N03175	PL 2.1
002N03182	PL 2.1
002N03187	PL 3.1
006N01361	PL 4.3
007N01802	PL 4.6
007N01803	PL 4.6
011N00581	PL 4.1
022N02795	PL 4.2
022N02796	PL 4.2
022N02797	PL 4.4
022N02802	PL 4.5
022N02803	PL 4.1
050N00681	PL 4.4
050N00682	PL 6.1
050N00683	PL 6.1
062N00292	PL 4.1
105N02299	PL 4.1
105N02300	PL 4.1
105N02301	PL 4.1
117N01969	PL 4.1
120N00545	PL 4.4
120N00548	PL 4.4
121N01247	PL 4.1
121N01248	PL 4.1
126N00430	PL 5.1
126N00431	PL 5.1
127N07865	PL 4.6
130N01758	PL 4.1
130N01758	PL 4.5
130N01758	PL 4.3
130N01759	PL 4.4
130N01760	PL 4.5
140N63706	PL 1.1
140N63707	PL 1.1
140N63708	PL 1.1
140N63709	PL 1.1

Table 1 Part Number Index

Part Number	Part List
140N63710	PL 1.1
140N63711	PL 1.1
140N63712	PL 1.1
140N63713	PL 1.1
140N63723	PL 3.1
140N63727	PL 1.1

---

## 6 General Procedures and Information

### General Information

General Information .....	6-3
System Overview .....	6-3
Product Specifications.....	6-7

### General Procedures

GP 1 Diagnostics Entry and Exit .....	6-9
GP 2 Machine Reports.....	6-9
GP 3 Machine Firmware Version .....	6-10
GP 4 Machine Settings .....	6-11
GP 5 Altitude Adjustment .....	6-11
GP 6 Firmware Upgrade .....	6-12
GP 7 Usage of the Electrostatic Discharge (ESD) Field Service Kit.....	6-13
GP 8 Software ServiceTools .....	6-13

### Diagnostics

Diagnostic (EDC) Mode .....	6-15
Machine Reports .....	6-16P



## General Information

The Xerox® Phaser® 3052/3260 printer produces high quality prints from electronic documents with speeds of up to 29 ppm and output resolution of up to 1200 x 1200 dpi.

## System Overview

This section provides illustrations of the following systems:

- Paper Path - [Figure 1](#)
- System Layout - [Figure 2](#)
- Print Process - [Figure 3](#)
- Laser Scanner Unit (LSU) - [Figure 4](#)
- Drives - [Figure 5](#)
- Toner System - [Figure 6](#)

Some features and options may not be available depending on machine configuration. Refer to the Xerox® Phaser® 3052NI/ 3260DI/ 3260DNI/ 3260DN User Guide for detailed feature and configuration information.

## Paper Path

The following diagrams display the path that the paper follows during the printing process.

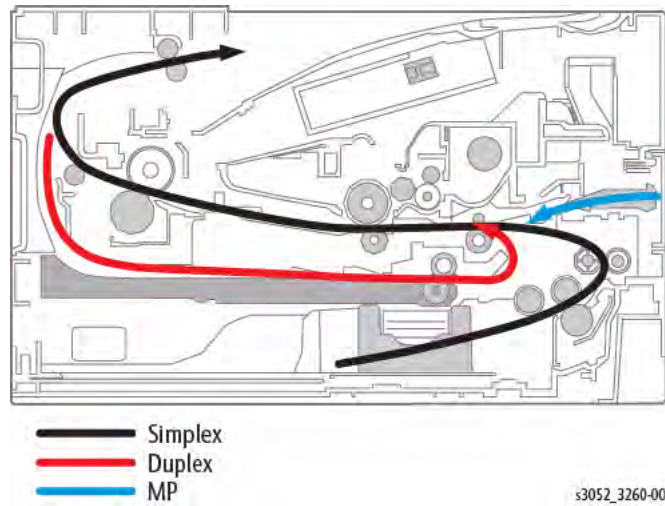

Figure 1 Paper Path

## System Layout

The figures below illustrates the mechanical parts of the printer.

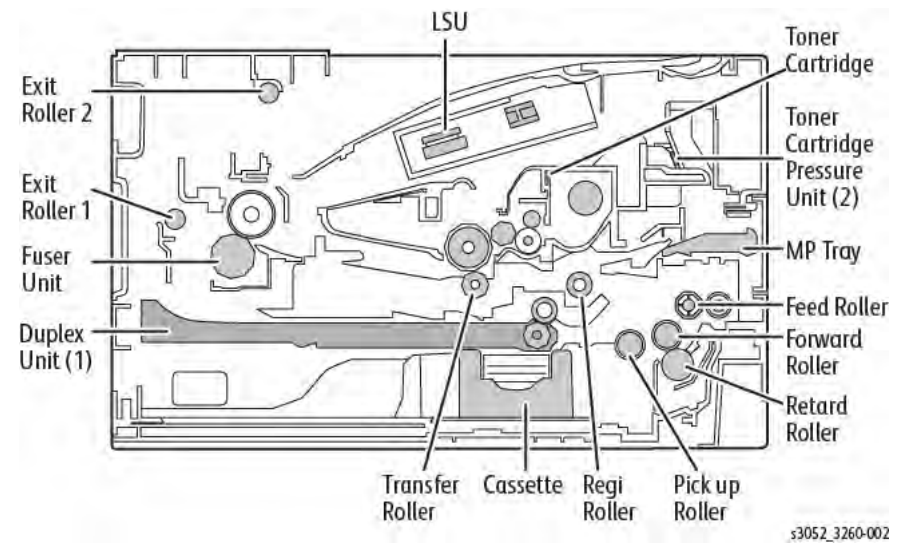

Figure 2 System Layout



## Print Process

Figure 3 presents a general layout of the fusing and printing components used in the print process.

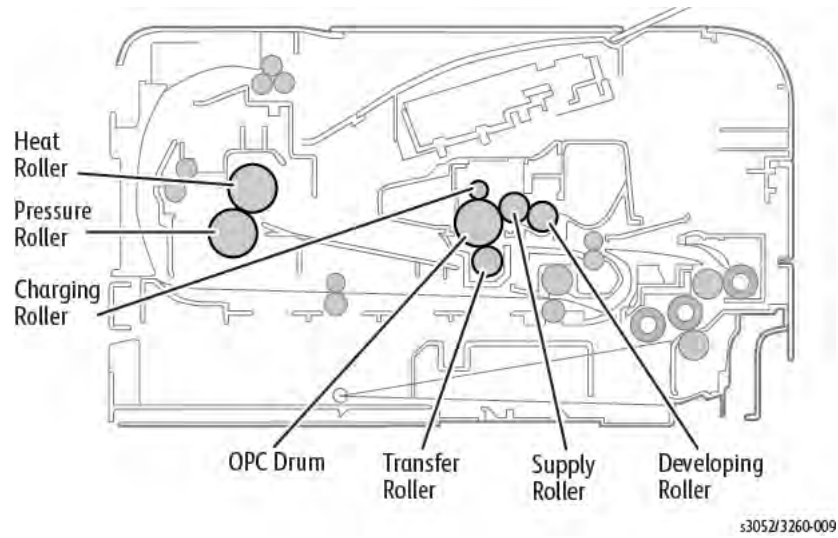

Figure 3 Print Process

## Laser Scanner Unit (LSU)

The Scanner Unit receives image data from the HVPS PWB and scans the surface of the photoreceptor drum (OPC) with a laser to create a latent image.

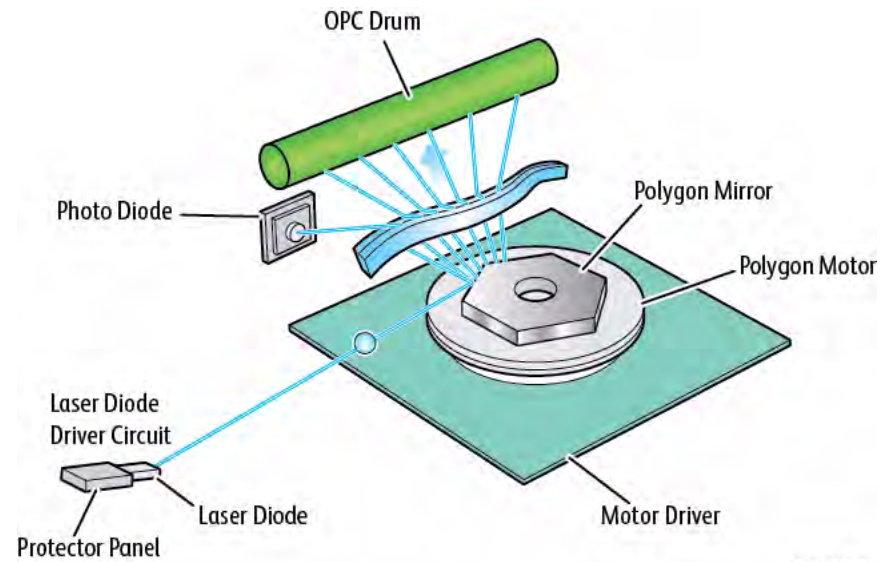
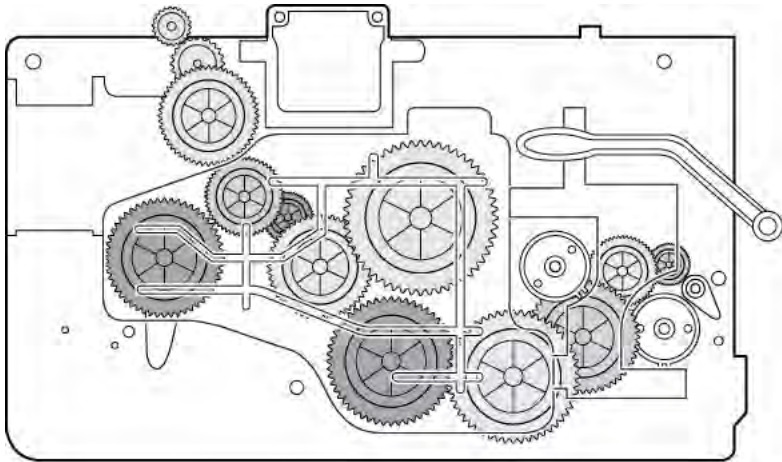

Figure 4 Laser Scanner Unit

## Drives

The Drive System consists of the Main (BLDC) Motor, Registration and Pick-up Clutches along with various gears for the Drum Cartridge (OPC), Fuser, Pick-up, Registration, Feed and Exit Rollers.



s 3052/3260-003

Figure 5 Drive Gears and Clutches

## Toner System

The printer uses a separated toner system comprised of a Toner Cartridge and Imaging Unit.

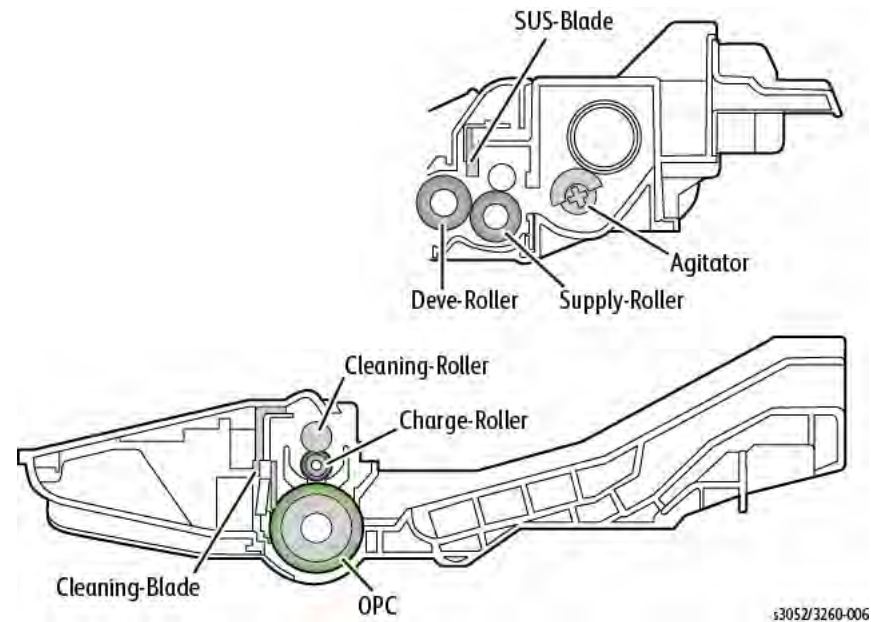

s 3052/3260-006

Figure 6 Separated Toner System

# Product Specifications

**Table 1 Product Overview**

Feature	Phaser 3052NI	Phaser 3260DI, DNI
Speed	26 ppm (A4), 27 ppm (8.5 x 11 in.)	28 ppm (A4), 29 ppm (8.5 x 11 in.)
Print Resolution	1200 x 1200 dpi	1200 x 1200 dpi
Processor	600MHz	600MHz
Printer Language Emulation	SPL, PCL5e, PCL6	SPL, PCL5e, PCL6
Memory	DDR3 128MB	DDR3 128MB
Interface	USB	High-speed USB 2.0
	USB Host Direct	Not supported
	Wired LAN	Ethernet 10/100 BaseTX
	Wireless LAN	802.11b/g/n wireless LAN
Control Panel	No LCD, 4 keys and 2 LEDs	No LCD, 4 keys and 2 LEDs
Toner Cartridge - Initial	1,500 images	1,500 images
Toner Cartridge - Standard/ High Yield	1500/3,000 images	1,500/ 3,000 images

**Table 2 General Print Engine Specifications**

Item	Mode	Phaser 3052NI	Phaser 3260DI, DNI
Engine Speed	Simplex	26 ppm (A4), 27 ppm (8.5 x 11 in.)	28 ppm (A4), 29 ppm (8.5 x 11 in.)
	Duplex*	13 ppm (A4), 14 ppm (8.5 x 11 in.)	14 ppm (A4), 15 ppm (8.5 x 11 in.)
Warmup time	From Sleep Mode	Less than 14 seconds	Less than 14 seconds
FPOT	From Sleep Mode	Less than 8.5 seconds	Less than 8.5 seconds
	From Standby	Less than 14 seconds	Less than 14 seconds
Resolution		1200 x 1200 dpi	1200 x 1200 dpi

**NOTE:** \*Applies to the 3260DI, 3260DNI, 3260DN models only.

**Table 3 Controller and Software**

Item	Specification	
Processor	CPU	600 MHz (Cortex A5)
	Image Processor	ReCP (Rendering Engine for Clean Page)
Memory		DDR3 256 MB
Printer Language	Phaser 3052NI	PCL5e/ PCL6, SPL
	Phaser 30260NI/ DNI	PCL5e/ PCL6, SPL, Postscript 3

**Table 3 Controller and Software**

Item	Specification	
Client OS Support	Windows®	XP, 2003 Server, Vista, 2008 Server, 7, 2008 Server R2, 8
	Linux	RedHat® Enterprise Linux WS 5, 6 (32/64 bit)
		Fedora 11-19 (32/64 bit)
		OpenSuSE® 11.0, 11.1, 11.2, 11.3, 11.4, 21.1, 12.2, 12.3 (32/64 bit)
Mandriva 2007, 2008, 2009, 2009.1, 2010 (32/64 bit)		
Ubuntu 10.04, 10.10, 11.04, 11.10, 12.04, 12.10, 13.04 (32/64 bit)		
SuSE Linux Enterprise Desktop 10, 11 (32/64 bit)		
Mint 13, 14, 15		
Debian 5.0, 6.0, 7.0, 7.1 (32/64 bit)		
Mac OS		Mac OS 10.5 thru 10.9
UNIX*		Sun Solaris 9,10, 11 (x86, SPARC)
		HP-UX 11.0, 11i v1, 11i v2, 11i v3 (PA-RISC, Itanium)
		IBM AIX 5.1, 5.2, 5.3, 5.4, 6.1, 7.1 (Power PC)
Fonts		PCL: 95 Scalable Fonts (Include OCR-A/OCR-B) / 1 Bitmap
Interface	USB	High Speed USB 2.0
	3052NI	Ethernet 10/100/1000 Base TX, 802.11b/g/n Wireless LAN
	3260DI	802.11b/g/n Wireless LAN
	3260DNI	Ethernet 10/100/1000 Base TX, 802.11b/g/n Wireless LAN
Network Protocol (2)		TCP/IP, TCP/IPv6
		DHCP, BOOTP, Bonjour, SLP, UPnP, Telnet, Standard TCP/IP Printing, LPR, IPP, SNMP v 1/2/3, HTTP, IPsec

**Table 4 Paper Handling Specifications**

Item	Specification	
Input Capacity	Standard	250 Sheet Cassette Tray / 1-sheet Manual Feeder
Output Capacity	Face Down	150 Sheets
	Face Up	1 Sheet
Printing Size	Max.	216 x 356 mm (8.5 x 14 in.)
	Min.	76 x 127 mm (3 in. x 5 in.)
Halftone		256 levels

**Table 4 Paper Handling Specifications**

Item		Specification
Standard Cassette Tray	Capacity	250 Sheets
	Media Size	8.5 x 11 in. (letter), 8.5 x 14 in. (legal), A4, A5, A6, Executive, Oficio, Folio, ISO B5, JIS B5
	Media Types	Plain, Light-weight, Heavy-weight, Cardstock, Recycled, Archive, Bond
	Media Weight	16 to 58 lb (60 to 220 gsm)
	Sensing	H/W Install Detect: No paper Empty: Yes Paper Type Detect: No Paper Size Detect: No
Manual Feeder	Capacity	1 Sheet
	Media Size	8.5 x 11 in. (letter), 8.5 x 14 in. (legal), A4, A5, A6, Executive, Oficio, Folio, ISO B5, JIS B5, Envelope: (No 10, Monarch, DL, C5, C6), Custom: 3 x 5 in. thru 8.5 x 14 in. (76mm x 127mm to 216 x 356 mm)
	Media Type	Plain, Light-weight, Heavy-weight, Cardstock, Transparency, Pre-printed, Recycled, Archive, Bond, Label, Envelope, Heavy-weight Envelope, Cotton, Colored
	Media Weight	16 to 58 lb (60 to 220 gsm)
	Sensing	Yes

**Table 5 Toner Cartridge/ Print Cartridge**

Machine Model	Item		Approx yield See note**
Separated Toner System			
	Toner Cartridge	Initial Cartridge	1500 images
		Standard Cartridge	1500 images
		High Yield Cartridge	3000 images
	Imaging Unit		10000 images

**NOTE:** \*\* Declared yield value in accordance with ISO/IEC 19752.

Depending on the options and job mode used, the toner cartridge's lifespan may differ.

When replacing a Toner/Print Cartridge, check model number and consumables code. Refer to the Phaser® 3052/3260 User Guide for information regarding ordering consumables.

**Table 6 Reliability and Service**

Item	Specification
Maximum Monthly Duty	12,000 pages
MPBF	30,000 pages
MTTR	30 minutes

**Table 7 Environment**

Item		Specification	
Acoustic Noise Level	Printing (Simplex)	Less than 50 dB	
	Standby	Less than 26 dB	
	Sleep Mode	Less than 26 dB	
Power Consumption	Ready	Less than 45 W	
	Normal Operation	Less than 400 W	
	Max/Peak	Less than 450 W	
	Sleep	Less than 0.9 W	
	Power Off	Less than 0.2 W	
	TEC	Less than 1.1 kWh per week	
Certification	Telecommunication	TBR-21, KC, Part68, ICES03, CE(EN), KCC	
	Safety	cUL, CB, KC, TUV-GS, PSB	
	EMC/EMI	FCC Part 15 Class B, ICES003, CE(EN), KCC	
	Document	No	
	Security	No	
	Others	No	
Dimension (W x D x H)	SET	14.5 x 13.2 x 8.0 in. (368 x 334.5 x 202 mm)	
	SET Packing	(452 x 418 x 330 mm) 17.8 x 16.5 x 13.0 in.	
Weight	Net (SET without consumables)	3.8 lbs (6.3 kg)	
	Net (SET with consumables)	7.2 lbs (6.3 kg)	
	Gross (SET with packaging)	9.1 lbs (20.1 kg)	
	Consumable (without packaging)	Toner Cartridge	1.2K: 1.10 lbs (0.50 kg) 3.0K: 1.19 lbs. (0.54 kg)
		Imaging Unit	0.84 lbs. (0.38 kg)

## GP 1 Diagnostics Entry and Exit

### Purpose

This procedure describes the following items:

- How to enter the Diagnostic (EDC) Mode
- The EDC menu
- How to exit Diagnostics

### Procedure

Use these steps to enter Diagnostics:

1. Obtain the EDC tool and download it onto the PWS.
  - The EDC tool is available from the GSN website.
2. Connect to the printer with a USB cable.
3. Switch On the power to the printer.
4. When the printer is in Ready mode, open the EDC ReadData application and select **[Run]** in the Compressed (zipped) Folders dialog box.
5. First, select **[Update LCD]** in the EDC dialog box to enable download of all diagnostic menu strings before running the EDC application.
6. Press the **<Menu>** button.
7. Use the arrows to select the desired diagnostic function.
8. Select **<Enter>** to confirm menu choices and to run diagnostic tests.
9. Use the **<Upper Level>** button to stop diagnostic tests and to return to the previous menu level.

To exit Diagnostic Mode:

1. Press the **<Exit>** button.

Refer to Section 6, Diagnostics for a listing of available functions within EDC mode.

## GP 2 Machine Reports

### Purpose

This procedure is used to access and print machine reports. The information in the machine reports may be useful for troubleshooting problems.

### Procedure

To print a Configuration Report:

- From the Control Panel, press and hold the red **<Cancel>** button for about 4 seconds until the Status LED blinks fast, and release.

To print a Supplies and Usage Status Report:

- From the Control Panel, press and hold the red **<Cancel>** button for about 10 seconds and release

To print a Demo/Sample page:

- From the Control Panel, press and hold the red **<Cancel>** button until the machine status button starts blinking (2 seconds) and release.

### From Easy Printer Manager:

1. Connect to the printer via USB cable or wireless connection.
2. Open Easy Printer Manager.
3. Select the **[Settings]** tab then select the **[CentreWare Internet Services]** button.
4. Login to CWIS: User name (**admin**) Password (**1111**).

***NOTE:** It may be necessary to obtain the user name and password from the customer if they have been changed.*

5. Select the **[Status]** tab then, **[Current Settings, Print Information]** to access:
  - Machine Information
  - Security Information
  - Print Information and Reports:
    - Configuration
    - Network Configuration
    - Supplies Info
    - Usage Counters
    - Demo Page

Refer to the Phaser® 3052/3260 User Guide for the following:

- Section 1 Getting Started, Information Pages, for information on machine reporting and configuration using the Control Panel and CentreWare Internet Services (CWIS) including:
  - Configuration Report
  - Network Configuration
  - Information Pages
  - Supplies Information
  - Usage Counter

- Demo Page
- Section 6 Maintenance: Checking the Status of Consumables.
- Section 7 Troubleshooting, Machine Status Indicators, for:
  - LED color and status descriptions
  - Detailed information on printing machine reports.

## GP 3 Machine Firmware Version

### Purpose

Use this procedure to check the firmware version of the machine.

### Procedure

From the Control Panel:

1. Press the **<Cancel>** button for more than 4 seconds. The machine will print a Configuration Report listing the firmware version.

From CWIS:

1. Open the Xerox Easy Printer Manager to launch the CentreWare Internet Services (CWIS) application.
2. Log into CWIS: enter User name: **admin** and Password: **1111**.

***NOTE:** It may be necessary to obtain the user name and password from the customer if they have been changed.*

3. Select the **[Support]** Tab. The Firmware version is listed next to the Main Controller Board.

## GP 4 Machine Settings

### Purpose

This procedure is used to provide information on how to configure machine settings.

### Procedure

To change settings Using Easy Print Manager (EPM):

1. Connect to the Phaser® 3052/3260 Printer with a USB cable.
2. Open Easy Print Manager at your workstation.
3. Select **<Advanced Mode>** then select **<Machine Settings>**.
4. Select from the following menu items to change the machine settings.
  - System
  - Earth Smart
  - Input Tray
  - Layout
  - Printer
  - Emulation
  - Copy
  - Fax
  - Scan
  - Network Settings

From CWIS

1. Connect to the Phaser® 3052/3260 Printer wirelessly, or via a USB cable.
2. Open Easy Print Manager and select the **[CWIS]** icon.
3. Login in to CWIS. User name: (Admin) Password: (1111)

**NOTE:** It may be necessary to obtain the user name and password from the customer if they have been changed.

4. Select **[Properties]** and select from the following menu items to change the machine settings.
  - Firmware
  - System
  - Printer
  - Copy
  - Fax
  - Scan
  - E-mail Notification
  - Network Settings
  - Security

## GP 5 Altitude Adjustment

### Purpose

Print quality is affected by atmospheric pressure, which is determined by the height of the machine above sea level.

### Requirements

- WiFi or Network connection

### Procedure

1. Determine altitude of machine placement:

Table 1 Altitude Values

Altitude	Value
0 - 1000 M 0 - 3,280 ft.	Normal
1000 - 2000 M 3,280 - 6,561 ft.	High 1
2000 - 3000M 6,561 - 9,842 ft.	High 2
3000 - 4000 M 9,842 - 13,123 ft.	High 3
4000 - 5000 M 13,123 - 16,404 ft.	High 4

2. Connect to the printer via USB cable from the PWS.
3. Open Easy Printer Manager. Select: **[Machine Settings, System, Altitude Adjustment]**.
4. Select correct value from the drop down menu.

To adjust altitude settings using a wireless connection, refer to the Phaser® 3052/3260 User Guide, Section 2. Installation and Setup

## GP 6 Firmware Upgrade

### Purpose

This procedure is used to update the machine firmware. The firmware can be updated over the network or via the USB port.

### Requirements

- Wired or wireless connection to upgrade using the network.
- The usblast2.exe tool, located in the GSN website, installed on the PWS device.
- Correct firmware file for update.
- Firmware Upgrade must be enabled in the machine settings on the printer.
- Complete or delete all jobs in the printer queue before initiating a firmware upgrade.

### Procedure

#### Upgrading the Firmware using a USB Port:

1. Connect a USB cable from the PWS to the USB port on the printer.
2. Confirm that the printer is the Ready status.
3. Drag the SWUPGRADE\_ON.prn file and drop it onto usblast2.exe. (This file enables firmware upgrades on the device). From Diagnostics Mode, select **[F/W Upgrade/On]** in Data Setup.
4. Drag and drop the firmware file onto usblast2.exe. The firmware update will start automatically.
5. Printer will reboot when the upgrade is complete.

#### Upgrading the Firmware using the Network:

1. Open a web browser and enter the machine's IP address.
2. Press <Enter>. The CentreWare Internet Services window will open.
3. Select the **Login** link at the top of the screen.
4. Enter the Administrator User name (**admin**) and Password (**1111**). The Firmware Upgrade window will open.

**NOTE:** It may be necessary to obtain the user name and password from the customer if they have been changed.

5. Click on the **Properties** tab.
6. In the **Security link**, select **System Security**.
7. Select the **Feature Management** link in the directory tree.
8. Select the **Firmware Upgrade Enable** box.
9. Click **Apply** to save the changes.
10. Select the **Support** tab.
11. In the **Firmware Upgrade** link, select the **Upgrade Wizard** button.
  - a. In the Firmware File area, select **Browse**.
  - b. Locate and select the correct firmware upgrade .hd file.
  - c. Select **Open**.

12. Select **Next**. The firmware will now be verified and display information about the upgrade.
13. Select **Next** to continue. The upgrade should take approximately 10 minutes.
14. The machine will reboot automatically when the upgrade has completed.
15. Print a Configuration Report and verify that the firmware has been successfully upgraded.



## GP 7 Usage of the Electrostatic Discharge (ESD) Field Service Kit

### Purpose

The purpose of the Electrostatic Discharge (ESD) Field Service Kit is to preserve the inherent reliability and quality of sensitive electronic components handled by the service representative. The kit should be used whenever handling the circuit boards or any other ESD sensitive components.

### Procedure

1. Switch off the machine power and disconnect the machine power cords.
2. Assemble the kit:
  - a. Place the static dissipative work surface mat on a flat surface in close proximity to the machine or the component
  - b. Connect the snap end of the green grounding cord to the snap on the static dissipative work surface mat. Connect the male end (plug) to the frame.
  - c. Connect the small snap end of the blue cord to the top snap on the green grounding cord.
  - d. Connect the small snap end of the blue cord to the snap on the adjustable cloth wrist strap or the ESD wristwatch.
  - e. Install the adjustable wrist strap or ESD wristwatch securely on the wrist.
3. The circuit boards (PWB's) and ESD sensitive components can now be handled without causing any ESD related damage. Place all of the components removed from the machine onto the static dissipative work surface mat.
4. New replacement components, as well as defective components, should be handled during unpacking and repacking using the ESD Field Service Kit. During transfer from or to the packing material or container, the PWB should be placed on the static dissipative work surface mat.

## GP 8 Software ServiceTools

### Purpose

Use this procedure access and download the software service tools.

### Procedure

1. To access the software tools file go to:
  - GSN Library #7387
  - <https://www.xrxgsn.com/secure/main.pl?catid=13991>
  - Software\_tools.zip
2. Download the Software\_tools.zip file onto the PWS.
3. Open the zip folder and extract the tool files.
4. The WorkCentre® 3052/3060 uses the following tools:
  - SWUPGRADE\_ON.prn - to enable the machine to accept software downloads
  - usblist2.exe - to download software via USB connection.
  - USB Serial Number Writing Tool - to write the machine serial number to the Main PWB.
  - EDC tool - to enter Diagnostic Mode



## Diagnostic (EDC) Mode

Enter Diagnostic (EDC) Mode, using the steps outlined below. Refer to Section 6 General Procedures GP1, Diagnostics Entry and Exit, for detailed instructions.

1. Connect to the printer with a USB cable.
2. When the printer is in Ready mode, open the EDC ReadData application and select **[Run]** in the Compressed Folders dialog box.
3. Select [Update LCD] in the EDC dialog box.
4. From the EDC window, select the **<Menu>** button.

**NOTE:** Allow 1 second for the printer to process the command before making the next menu selection.

5. Once in EDC Mode, use the arrows to select the following sub-menus:
  - NVM Read/Write
  - NVM Initialize
  - Test Routines

Select the **<Enter>** button to confirm menu selections and run diagnostics tests.

Select the **<Upper Level>** button to stop tests.

Select the **<Exit>** button to exit EDC mode.

**Table 1 EDC Mode Menu**

Level 1	Level 2	Level 3	Level 4
NVM Read/ Write	105 Charger	MHV DC K	[50-900]
	106 Development	Deve DC K	[50-900]
	107 Transfer	[THV] K	[50-900]
		[THV] K_Dup	[50-900]
	109 Fuser	Ready Temp	[-10 - 10]
Print Temp		[-10 - 10]	
	110 LSU	LD Power K	[50-900]
NVM Initialize	[Yes/No]		

**Table 1 EDC Mode Menu**

Level 1	Level 2	Level 3	Level 4
Test Routines	100 Motor	Main BLDC	Status [Off]
		Main BLDC Rdy	Status: [Low]
	101 Clutch	Tray 1 Pickup	Status: [Off]
		Registration	Status: [Off]
		Out Bin Full	Status: [Low]
	102 Sensor	Tray 1 Empty	Status: [Low]
		Feed Sens	Status: [Low]
		Regi Sens	Status: [Low]
		Exit Sens	Status: [Low]
	105 Charger	K MHV Bias	Status: [Off]
	106 Development	K Dev Bias	Status: [Off]
	107 Transfer	K THV Bias	Status: [Off]
		K THV - Bias	Status: [Off]
		K [THV] Bias R	Status: [0]
	109 Fuser	Temp A	Status: [0]
110 LSU	LSU Mot1 Rdy	Status: [Low]	
	LSU Mot1 Run	Status: [Off]	
	LD Power4	Status: [Off]	
	LSU HSync4	[Low]	

## Machine Reports

Refer to the Phaser® 3052/3260 User Guide for the following:

- Section 1 Getting Started, Information Pages, for information on machine reporting and configuration using the Control Panel and CentreWare Internet Services (CWIS) including:
  - Configuration Report
  - Network Configuration
  - Information Pages
  - Supplies Information
  - Usage Counter
  - Demo Page
- Section 6 Maintenance: Checking the Status of Consumables.
- Section 7 Troubleshooting, Machine Status Indicators, for:
  - LED color and status descriptions
  - Detailed information on printing machine reports.

Xerox® Phaser® 3052/3260 Printer  
BLOCK SCHEMATIC DIAGRAMS  
June, 2014

This document contains wiring and mechanical power data for the Xerox® Phaser® 3052/3260 Printers. These block schematic diagrams are supplemental to the diagnostic and troubleshooting information found in the Xerox Phaser 3025/3260 Family Service Manual.

Every effort has been made to achieve accuracy on these schematics. However, if a difference is noted between these schematics and the Xerox Service Documentation, the Service Documentation takes precedence.

## TABLE OF CONTENTS

<b>CHAIN 1</b>	<b>POWER</b>
1.1	AC / LOW VOLTAGE And HIGH VOLTAGE POWER / INTERLOCKS
<b>CHAIN 3</b>	<b>COMMUNICATIONS</b>
3.1A	PRINTER COMMUNICATION
3.1B	PRINTER COMMUNICATION
<b>CHAIN 4</b>	<b>MAIN DRIVE</b>
4.1	MAIN DRIVE
<b>CHAIN 6</b>	<b>LSU</b>
6.1	LSU
<b>CHAIN 7</b>	<b>PAPER FEED AND REGISTRATION</b>
7.1	PAPER FEED AND REGISTRATION
<b>CHAIN 9</b>	<b>XEROGRAPHICS</b>
9.1	PRINT MODULE
<b>CHAIN 10</b>	<b>FUSING AND PRINT EXIT</b>
10.1	FUSING
10.2	PRINT EXIT

Prepared by:

Content Development and Language Services - North America

Xerox Corporation

800 Phillips Road; Building 0218-01A

Webster, New York 14580 USA

THIS PAGE INTENTIONALLY BLANK

1.1 AC / LOW VOLTAGE and HIGH VOLTAGE POWER / INTERLOCKS

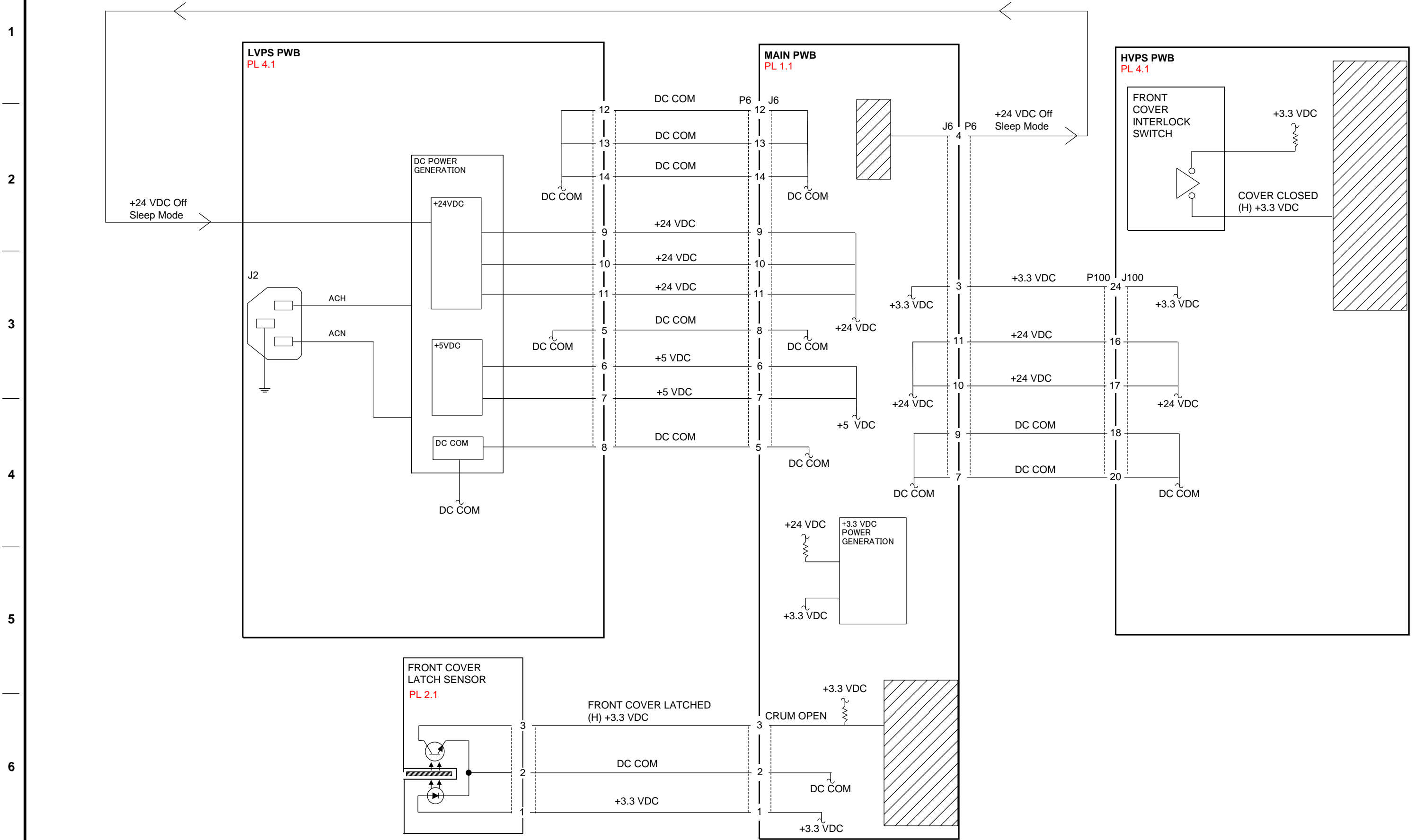





3.1B COMMUNICATIONS (2 of 2)

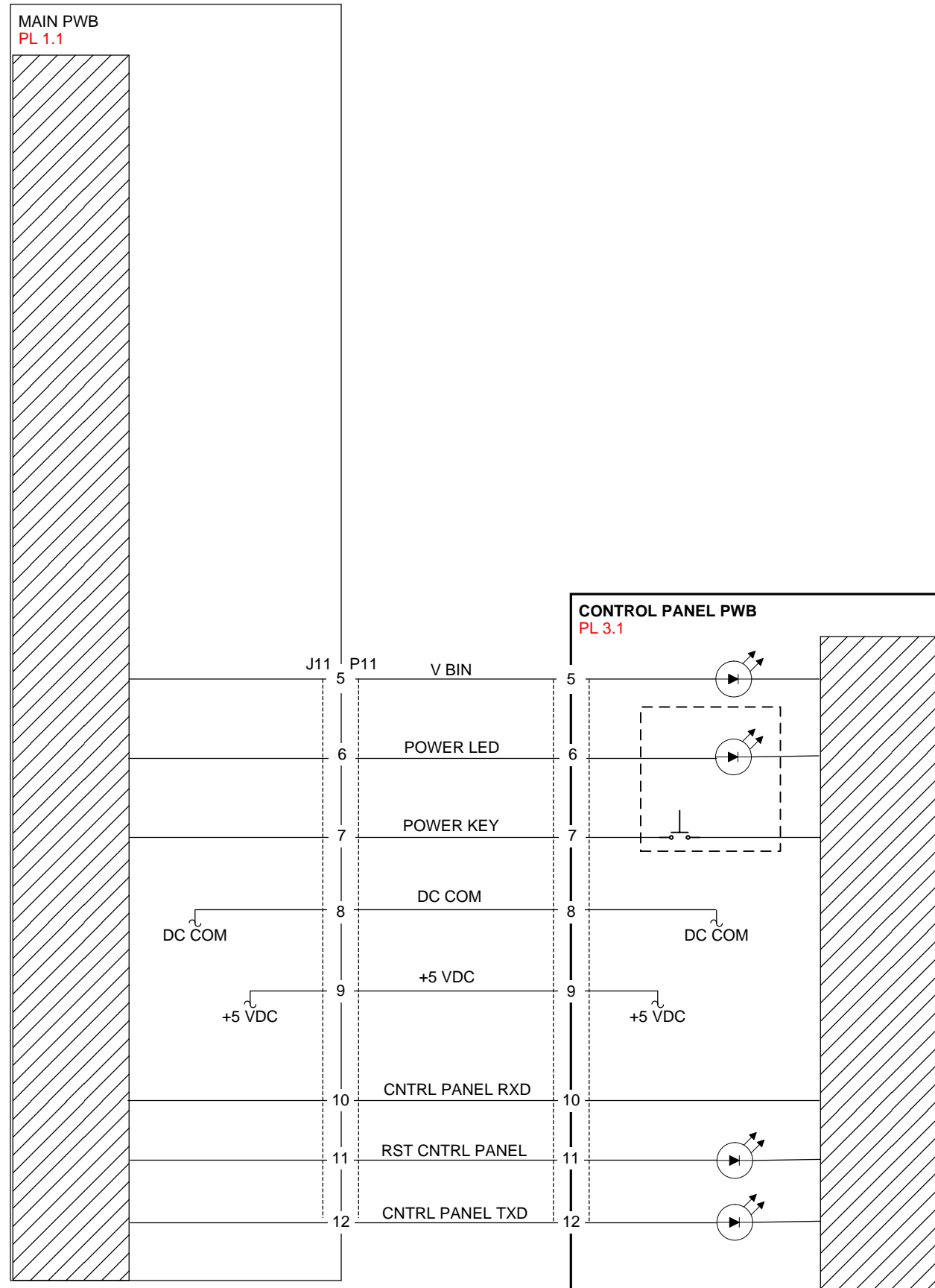

1

2

3

4

5

6

4.1 MAIN DRIVE

1

2

3

4

5

6

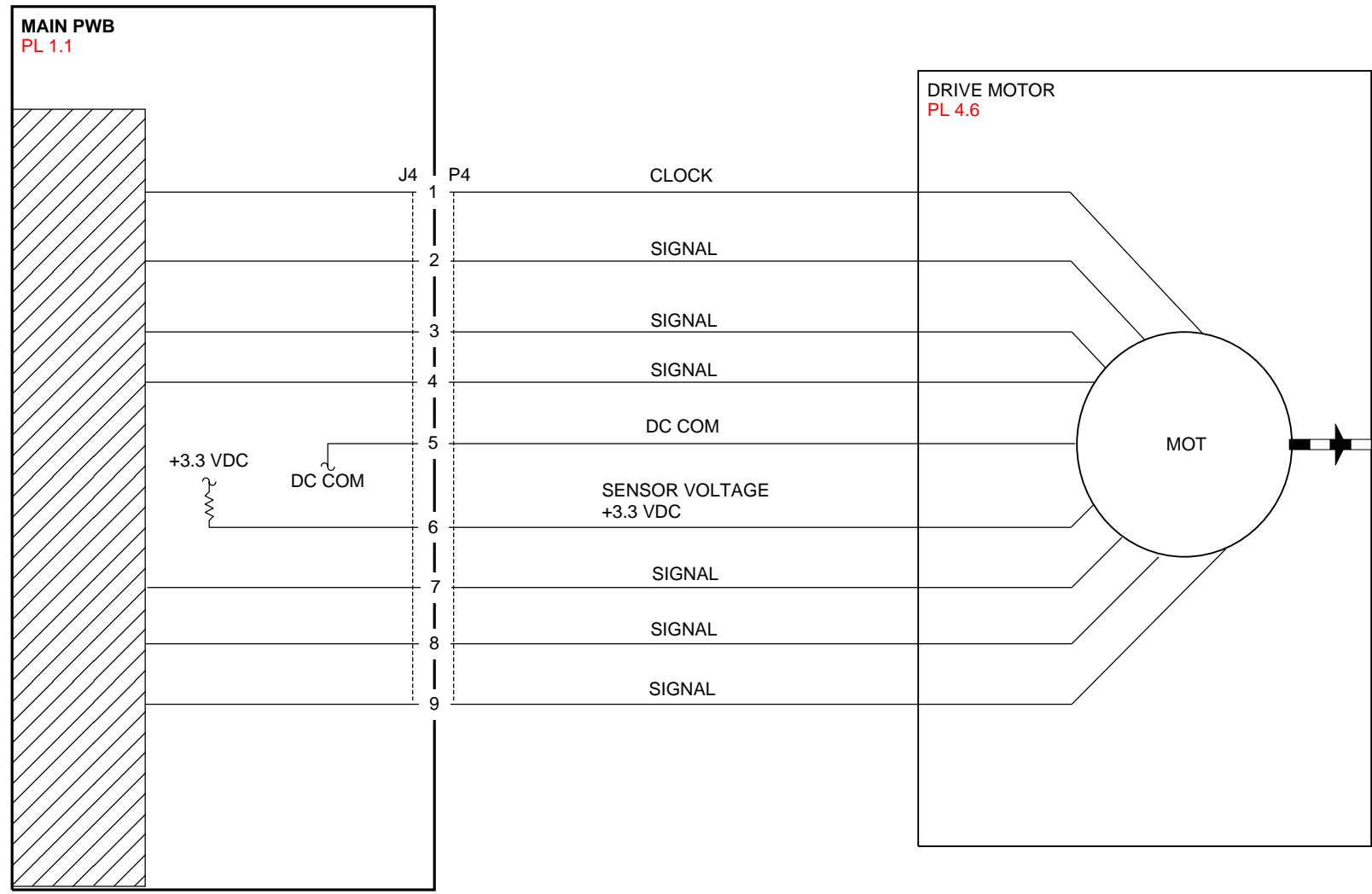

6.1 LSU

MAIN PWB  
PL 1.1

LSU  
PL 4.1

1

2

3

4

5

6



7.1 PAPER FEED AND REGISTRATION

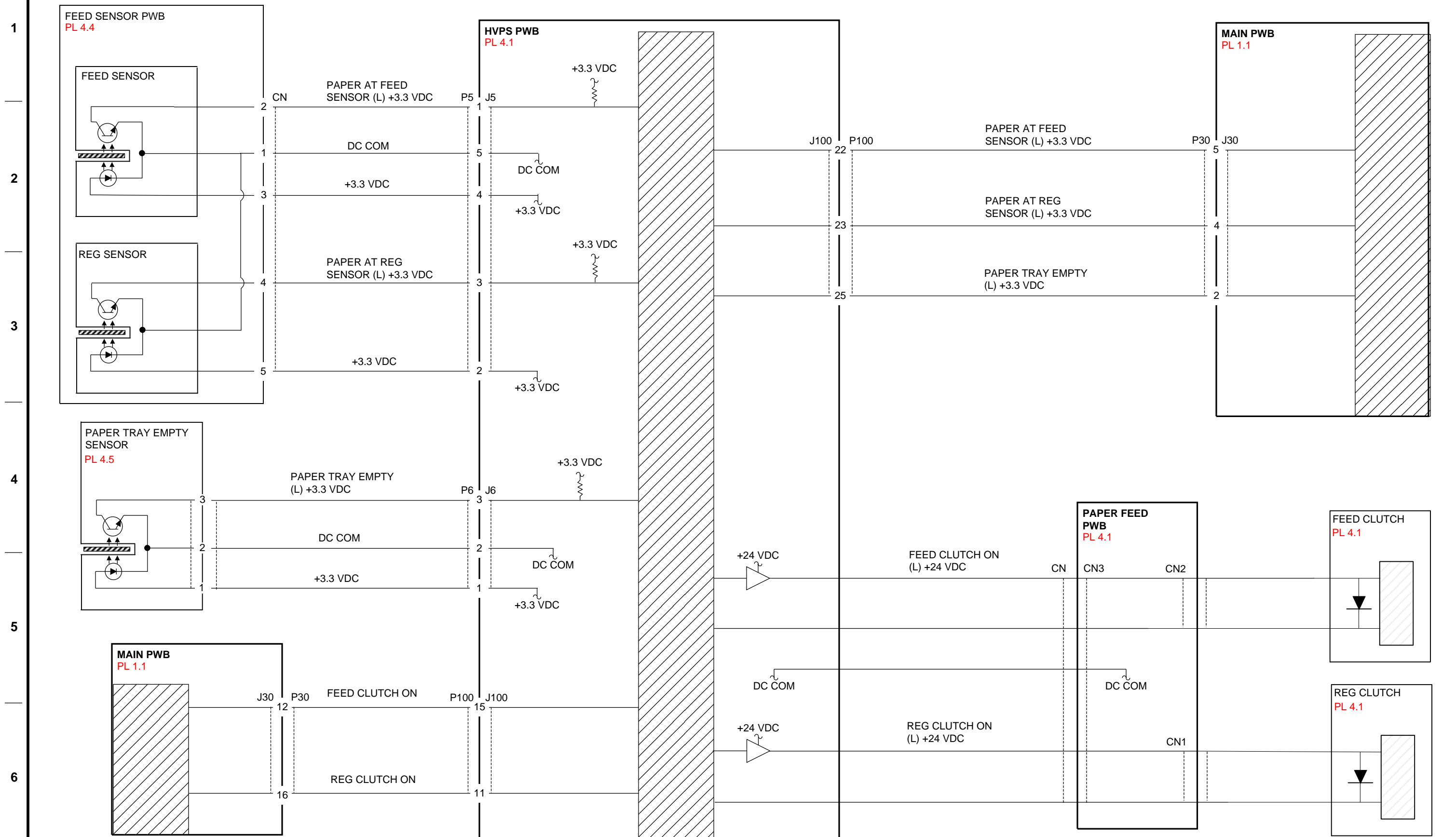

9.1 XEROGRAPHICS

1

2

3

4

5

6

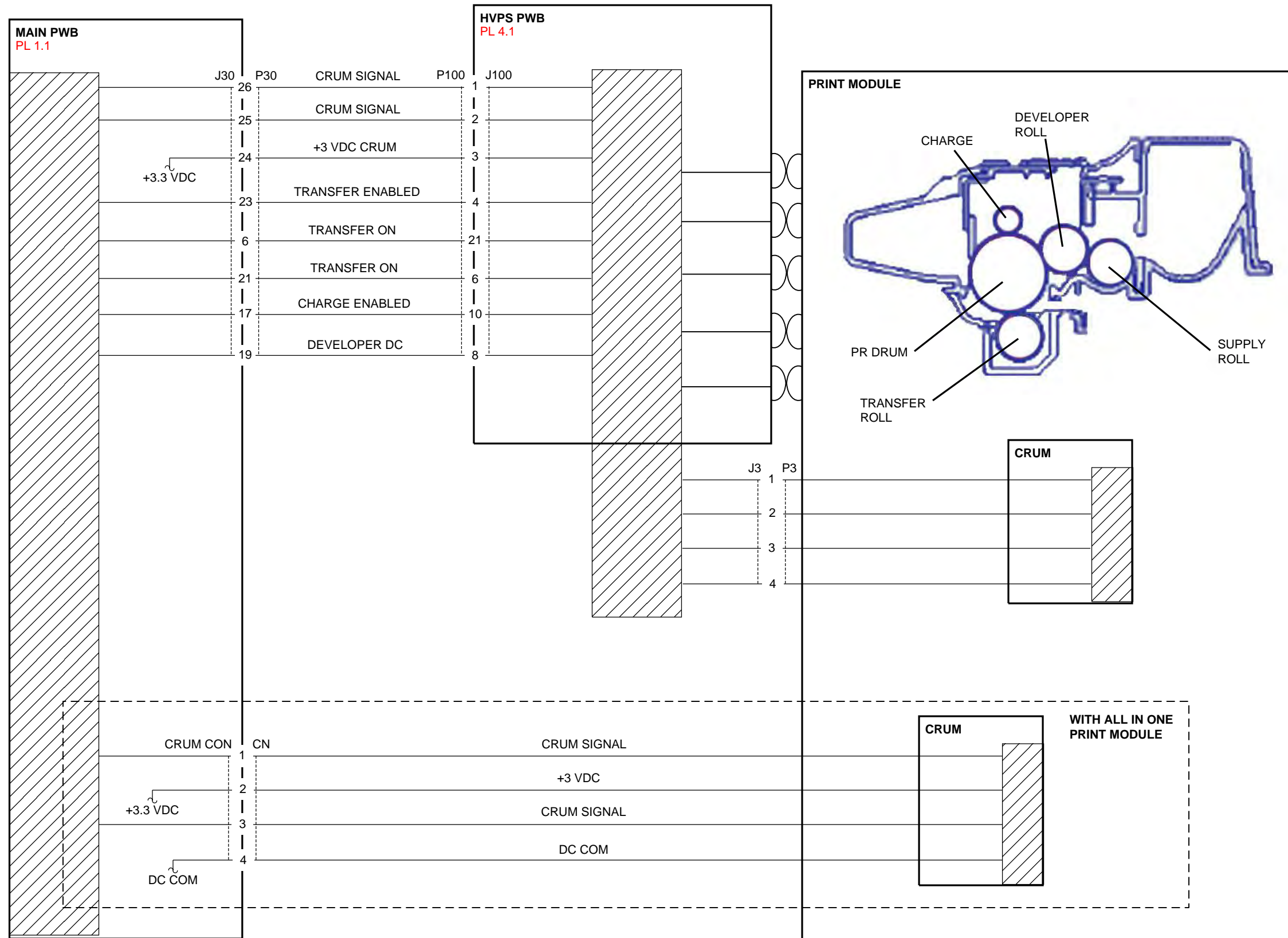

10.1 FUSER

1  
2  
3  
4  
5  
6

A B C D E F G H J

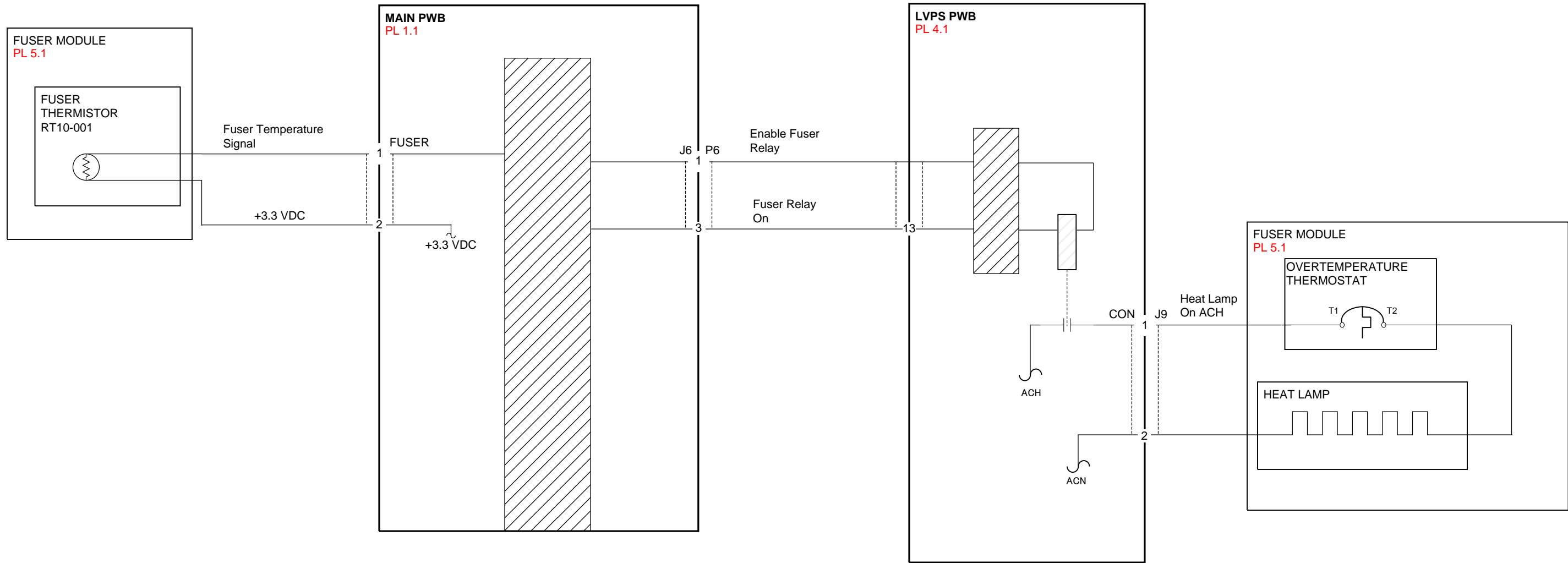

10.2 PRINT EXIT

1  
2  
3  
4  
5  
6

A B C D E F G H J

