

# Phaser 3100MFP

## SERVICE MANUAL



# XEROX®

708P89057

Phaser 3100MFP

Service Documentation

708P89057

04/08

Prepared by:

Xerox Europe,

Global Knowledge & Language Services,

Enterprise Centre,

P.O. Box 17,

Bessemer Road,

Welwyn Garden City,

Hertfordshire,

AL7 1BU, England.

© Copyright 2008 by Xerox Ltd.

Xerox, and all identifying numbers used in connection with the Xerox products mentioned in this publication are registered trademarks of Xerox. Other company trademarks are also acknowledged.

## NOTICE

While every care has been taken in the preparation of this manual, no liability will be accepted by Xerox Europe arising out of any inaccuracies or omissions.

All service documentation is supplied to Xerox external customers for informational purposes only. Xerox service documentation is intended for use by certified, product trained service personnel only. Xerox does not warrant or represent that it will notify or provide to such customer any future change to this documentation. Customer performed service of equipment, or modules, components or parts of such equipment may affect whether Xerox is responsible to fix machine defects under the warranty offered by Xerox with respect to such equipment. You should consult the applicable warranty for its terms regarding customer or third-party provided service.

---

## Introduction

Safety Precautions .....	<a href="#">iii</a>
Health and Safety Incident Reporting .....	<a href="#">viii</a>

## 1 Service Call Procedures

Section Contents .....	<a href="#">1-1</a>
------------------------	---------------------

## 2 Repair Analysis Procedures

Section Contents .....	<a href="#">2-1</a>
------------------------	---------------------

## 3 Image Quality

Section Contents .....	<a href="#">3-1</a>
------------------------	---------------------

## 4 Repairs and Adjustments

Section Contents .....	<a href="#">4-1</a>
------------------------	---------------------

## 5 Parts List

Section Contents .....	<a href="#">5-1</a>
------------------------	---------------------

## 6 General Procedures and Information

Section Contents .....	<a href="#">6-1</a>
------------------------	---------------------

## 7 Wiring Data

Section Contents .....	<a href="#">7-1</a>
------------------------	---------------------

This page is intentionally blank

## Safety Precautions

In order to prevent accidents and to prevent damage to the equipment, please read the precautions listed below carefully before servicing the machine and follow them closely.

Warnings, Cautions and Notes

### WARNING

A warning is used whenever an operating or maintenance procedure, practice, condition or statement, if not strictly observed, could result in personal injury.

### CAUTION

A caution is used whenever an operation or maintenance procedure, practice, condition or statement, if not strictly observed, could result in damage to the equipment.

**Note:** A note is used where it is essential to highlight a procedure, practice, condition or statement.

## Safety Warning

1. Only to be serviced by appropriately qualified service engineers.  
High voltages and lasers inside this product are dangerous. This machine should only be serviced by a suitably trained and qualified service engineer.
2. Use only Xerox replacement parts  
There are no user serviceable parts inside the machine. Do not make any unauthorized changes or additions to the machine, these could cause the machine to malfunction and create electric shock or fire hazards.
3. Laser Safety Statement  
The machine is certified in the U.S. to conform to the requirements of DHHS 21 CFR, chapter 1 Subchapter J for Class 1(1) laser products, and elsewhere, it is certified as a Class I laser product conforming to the requirements of IEC 825. Class I laser products are not considered to be hazardous. The laser system and machine are designed so there is never any human access to laser radiation above a Class I level during normal operation, user maintenance, or prescribed service condition.



### WARNING

Follow the service procedure exactly as written. Use of controls or adjustments other than those specified in this manual, may result in an exposure to invisible laser radiation. During servicing, the invisible laser radiation can cause eye damage if looked at directly.

### Materials

1. If the LCD control panel is damaged, it is possible for the liquid inside the display to leak. Contact with skin should be avoided, wash any splashes from eyes or skin immediately and contact your doctor. If the liquid gets into the mouth or is swallowed see a doctor immediately.
2. Please keep print cartridges away from children.

### Electric Shock and Fire Safety Precautions

Failure to follow the following instructions could cause electric shock or potentially cause a fire.

1. Use only the correct voltage, failure to do so could damage the machine and potentially cause a fire or electric shock.
2. Use only the power cable supplied with the machine. Use of an incorrectly specified cable could cause the cable to overheat and potentially cause a fire.
3. Do not overload the power socket, this could lead to overheating of the cables inside the wall and could lead to a fire.
4. Do not allow water or other liquids to spill into the machine, this can cause electric shock. Do not allow paper clips, pins or other foreign objects to fall into the machine these could cause a short circuit leading to an electric shock or fire hazard.
5. Never touch the plugs on either end of the power cable with wet hands, this can cause electric shock. When servicing the machine, remove the power plug from the wall socket.
6. Use caution when inserting or removing the power connector. The power connector must be inserted completely otherwise a poor contact could cause overheating and possibly leading to a fire. When removing the power connector grip it firmly and pull.
7. Take care of the power cable. Do not allow it to become twisted, bent sharply round corners or otherwise damaged. Do not place objects on top of the power cable. If the power cable is damaged, it could overheat and cause a fire or exposed wires could cause an electric shock. Replace a damaged power cable immediately, do not reuse or repair the damaged cable. Some chemicals can corrode the coating on the power cable, weaken the cover or exposing wires causing fire and shock risks.
8. Ensure that the power sockets and plugs are not cracked or broken in any way. Any such defects should be repaired immediately. Take care not to cut or damage the power cable or plugs when moving the machine.
9. Avoid damp or dusty areas, install the machine in a clean well ventilated location. Do not position the machine near a humidifier. Moisture and dust build up inside the machine can lead to overheating and cause a fire.
10. Do not position the machine in direct sunlight.
11. Do not insert any metal objects into the machine through the ventilator fan or other part of the casing, it could make contact with a high voltage conductor inside the machine and cause an electric shock.

### Handling Precautions

The following instructions are for your own personal safety, to avoid injury and so as not to damage the machine

1. Ensure the machine is installed on a level surface, capable of supporting its weight. Failure to do so could cause the machine to tip or fall.

2. The machine contains many rollers, gears and fans. Take great care to ensure that you do not catch your fingers, hair or clothing in any of these rotating devices.
3. Do not place any small metal objects, containers of water, chemicals or other liquids close to the machine which if spilled could get into the machine and cause damage or a shock or fire hazard.
4. Do not install the machine in areas with high dust or moisture levels, beside an open window or close to a humidifier or heater. Damage could be caused to the machine in such areas.
5. Do not place candles, burning cigarettes, etc. on the machine, these could cause a fire.
6. The fuser unit works at a high temperature. Use caution when working on the machine. Wait for the fuser to cool down before disassembly.

### **Assembly / Disassembly Precautions**

Replace parts carefully, always use Xerox parts. Take care to note the exact location of parts and also cable routing before dismantling any part of the machine. Ensure all parts and cables are replaced correctly.

Please carry out the following procedures before dismantling the machine or replacing any parts.

1. Check the contents of the machine memory and make a note of any user settings. These will be erased if the mainboard is replaced.
2. Ensure that power is disconnected before servicing or replacing any electrical parts.
3. Disconnect printer interface cables and power cables.
4. Be sure to remove the print cartridge before you disassemble any parts.
5. Only use approved spare parts. Ensure that part number, product name, any voltage, current or temperature rating are correct.
6. When removing or re-fitting any parts do not use excessive force, especially when fitting screws into plastic.
7. Take care not to drop any small parts into the machine.
8. Handling of the OPC Drum

- The OPC Drum can be irreparably damaged if it exposed to light.

Take care not to expose the OPC Drum either to direct sunlight or to fluorescent or incandescent room lighting. Exposure for as little as 5 minutes can damage the surface's photoconductive properties and will result in print quality degradation. Take extra care when servicing the machine. Remove the OPC Drum and store it in a black bag or other lightproof container. Take care when working with the covers (especially the top cover) open as light is admitted to the OPC area and can damage the OPC Drum.

- Take care not to scratch the green surface of OPC Drum Unit.

If the green surface of the Drum Cartridge is scratched or touched the print quality will be compromised.

### **ESD Precautions**

Certain semiconductor devices can be easily damaged by static electricity. Such components are commonly called "Electrostatically Sensitive (ES) Devices", or ESDs. Examples of typical ESDs are: integrated circuits, some field effect transistors, and semiconductor "chip" components.

The techniques outlined below should be followed to help reduce the incidence of component damage caused by static electricity.

### **CAUTION**

*Be sure no power is applied to the chassis or circuit, and observe all other safety precautions.*

1. Immediately before handling a semiconductor component or semiconductor-equipped assembly, drain off any electrostatic charge on your body by touching a known earth ground. Alternatively, employ a commercially available wrist strap device, which should be removed for your personal safety reasons prior to applying power to the unit under test.
2. After removing an electrical assembly equipped with ESDs, place the assembly on a conductive surface, such as aluminium or copper foil, or conductive foam, to prevent electrostatic charge buildup in the vicinity of the assembly.
3. Use only a grounded tip soldering iron to solder or desolder ESDs.
4. Use only an “anti-static” solder removal device. Some solder removal devices not classified as “anti-static” can generate electrical charges sufficient to damage ESDs.
5. Do not use Freon-propelled chemicals. When sprayed, these can generate electrical charges sufficient to damage ESDs.
6. Do not remove a replacement ESD from its protective packaging until immediately before installing it. Most replacement ESDs are packaged with all leads shorted together by conductive foam, aluminium foil, or a comparable conductive material.
7. Immediately before removing the protective shorting material from the leads of a replacement ESD, touch the protective material to the chassis or circuit assembly into which the device will be installed.
8. Maintain continuous electrical contact between the ESD and the assembly into which it will be installed, until completely plugged or soldered into the circuit.
9. Minimize bodily motions when handling unpackaged replacement ESDs. Normal motions, such as the brushing together of clothing fabric and lifting one’s foot from a carpeted floor, can generate static electricity sufficient to damage an ESD.



# Health and Safety Incident Reporting

## I. Summary

This section defines requirements for notification of health and safety incidents involving Xerox products (equipment and materials) at customer locations.

## II. Scope

Xerox Corporation and subsidiaries worldwide.

## III. Objective

To enable prompt resolution of health and safety incidents involving Xerox products and to ensure Xerox regulatory compliance.

## IV. Definitions

### Incident:

An event or condition occurring in a customer account that has resulted in injury, illness or property damage. Examples of incidents include machine fires, smoke generation, physical injury to an operator or service representative. Alleged events and product conditions are included in this definition.

## V. Requirements

### Initial Report:

1. Xerox organisations shall establish a process for individuals to report product incidents to Xerox Environment Health & Safety within 24 hours of becoming aware of the event.
2. The information to be provided at the time of reporting is contained in Appendix A (Health and Safety Incident Report involving a Xerox product).
3. The initial notification may be made by any of the following methods:
  - For incidents in North America and Developing Markets West (Brazil, Mexico, Latin American North and Latin American South):
    - Phone\* Xerox EH&S at: 1-800-828-6571.
    - Electronic mail Xerox EH&S at: Doris.Bush@usa.xerox.com.
    - Fax Xerox EH&S at: 1-585-422-6449 [intelnet 8\*222 6449].
  - For incidents in Europe and Developing Markets East (Middle East, Africa, India, China and Hong Kong):
    - Phone\* Xerox EH&S at: +44 (0) 1707 353434.
    - Electronic mail Xerox EH&S at: Elaine.Grange@GBR.xerox.com.
    - Fax Xerox EH&S at: +44 (0) 1707 353914 [intelnet 8\*668 3914].

\*Initial notification made by phone must be followed within 24 hours by a completed incident report and sent to the indicated electronic mail address or fax number.

**Note:** *If sending a fax, please also send the original via internal mail.*

## **Responsibilities for Resolution:**

1. Business Groups/Product Design Teams responsible for the product involved in the incident shall:
  - a. Manage field bulletins, customer correspondence, product recalls, safety retrofits.
  - b. Fund all field retrofits.
2. Field Service Operations shall:
  - a. Preserve the Xerox product involved and the scene of the incident inclusive of any associated equipment located in the vicinity of the incident.
  - b. Return any affected equipment/part(s) to the location designated by Xerox EH&S and/or the Business Division.
  - c. Implement all safety retrofits.
3. Xerox EH&S shall:
  - a. Manage and report all incident investigation activities.
  - b. Review and approve proposed product corrective actions and retrofits, if necessary.
  - c. Manage all communications and correspondence with government agencies.
  - d. Define actions to correct confirmed incidents.

## **VI. Appendices**

The Health and Safety Incident Report involving a Xerox Product (Form # EH&S-700) is available at the end of the manual.

# 1 Service Call Procedures

SCP 1 Service Call Actions .....	<a href="#">1-3</a>
SCP 2 Cleaning.....	<a href="#">1-4</a>
SCP 3 Final Actions .....	<a href="#">1-7</a>

This page is intentionally blank

## SCP 1 Service Call Actions

### Procedure

#### **WARNING**

Switch off the electricity to the machine. Disconnect the power cord from the customer supply while performing tasks that do not need electricity. Electricity can cause death or injury. Moving parts can cause injury.

1. Take note of symptoms or error messages.
2. Ask the operator to describe or demonstrate the problem.
3. Make sure that:
  - The power cord is connected to the wall outlet and to the machine.
  - All cables are connected correctly.
  - If necessary perform [SCP 2 Cleaning](#).
4. If available, check the machine service log book for any previous actions that may be relevant to the call.
5. Review any defective print or copy samples.
6. Refer to [RAP 1 Error Codes](#) for a list of error codes and possible solutions.

## SCP 2 Cleaning

To keep the machine in good working condition, the following operations should be carried out regularly:

- Cleaning the paper transport rollers of the ADF (3100 MFP/X only).
- Cleaning the paper separator (3100 MFP/X only).
- Cleaning the CIS window of the scanner.
- Cleaning the control panel keys and the printer covers.
- Cleaning the printer with a soft cloth, **never use abrasives or detergents**.

### Paper Transport Rollers (3100 MFP/X only)

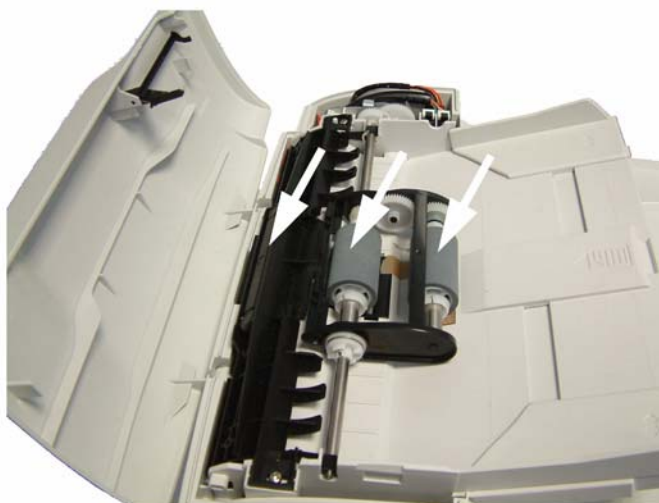
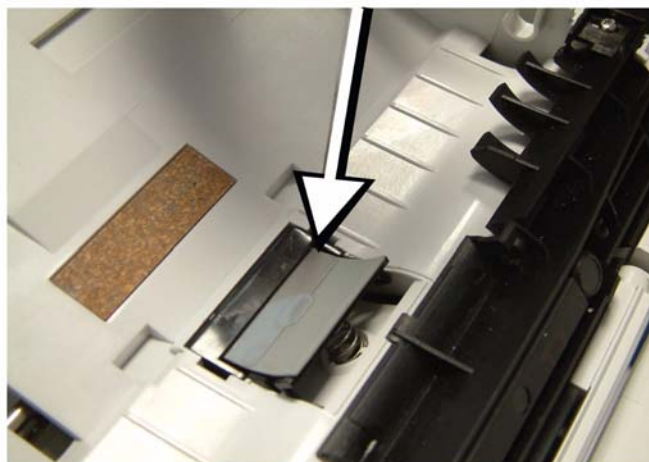

**Figure 1**

1. Set the On/Off switch to Off (position 0).
2. Open the ADF cover.
3. Clean the rollers of the document feeder and feed shafts, and also the two idler rollers located on the mobile part of the scanner, with a lint-free cloth moistened in isopropyl alcohol. To clean them, rotate them in the same direction as during paper transport.

**Recommended interval:** from 2 to 6 months, depending on utilization.

## Paper Separator Module (3100 MFP/X only)



**Figure 2**

1. Set the On/Off switch to Off (position 0).
2. Open the ADF scanner cover.
3. Disassemble the ADF feeder ([REP 4](#)).
4. Wipe the elements of the paper separator module with a lint-free cloth soaked with isopropyl alcohol. **Recommended interval:** from 2 to 6 months, depending on utilization.

### CIS and Document Glass

1. Set the On/Off switch to Off (position 0).
2. Open the scanner cover.
3. Clean the CIS window with a lint-free cloth moistened with isopropyl alcohol or use antistatic paper used for cleaning optic glass.

**Recommended interval:** depending on utilization; it is advisable to make a local copy to check if the window is clean.

### Control Panel Keys and Covers

#### Cleaning the Control Panel Keys

1. Set the On/off switch to Off (position 0).
2. Clean the top of the control panel and the keys with a lint-free cloth moistened with isopropyl alcohol or a spray-on cleaning product.
3. Leave the product on for a few seconds before wiping it off.

**Recommended interval:** to be defined depending on utilization.

### **Cleaning the Covers**

It is advisable to clean all the covers during a maintenance visit.

1. Set the On/Off switch to Off (position 0).
2. Clean the external areas of the covers with a lint-free cloth moistened with isopropyl alcohol or a spray-on cleaning product.
3. Leave the product on for a few seconds before wiping it off.



## SCP 3 Final Actions

After the machine has been re-assembled, perform the steps that follow:

1. Exercise the machine in all modes.
2. Make a proof copy or print of a customer document.
3. If any of the customers selections were changed, return them to the customers preferred settings.
4. Mark off any hardware/software options and modifications installed and/or enabled in the Service Log, [GP 19](#).
5. At the first service and at any subsequent service where changes are made or options are added, print the configuration report and store it with the machine log book. Discard any previous versions of the configuration report.
6. Remove and destroy any copies of test patterns.
7. Complete the machine service log, refer to [GP 19](#) Service Log.
8. Ensure the machine and service area are clean before leaving the customer premises.
9. Provide customer training if required.

This page is intentionally blank

## 2 Status Indicator RAPs

RAP 1 Error Codes .....	<u>2-3</u>
RAP 2 Jam Detection .....	<u>2-6</u>

This page is intentionally blank

## RAP 1 Error Codes

### Scanning and Communication Error Codes

The communication error codes appear in the logs (printed using key sequence **5 4**) and in the transmission reports.

### General Codes

The following table presents and details for each error code displayed by the machine its cause and when required the corrective action to perform.

**Table 1:**

<b>Code</b>	<b>Error</b>	<b>Cause</b>	<b>Action</b>
01	Engaged or no fax tone	This code appears after 6 failed attempts.	Restart the transmission at a later time.
03	Stopped by operator	Communication stopped by the operator by pressing the STOP key.	
04	Programmed number invalid	Invalid programmed single-key or quick-dial number (Example: a delayed transmission has been programmed with a single key and this key has been deleted).	Check the validity of the programmed number and/or the single-key associated to the programmed number.
05	Scanning fault	An error has occurred at the location of the document to be transmitted (Example: the sheet is jammed).	Check the ADF module.
06	Printer not available	An error has occurred on the printer (Example: out of paper, paper jam or cover open). In the case of a reception, this incident code only appears if the <b>RECEPTION WITHOUT PAPER</b> parameter is set to <b>WITHOUT PAPER</b> .	Check the printer.
07	Disconnect	The communication has been cut (bad connection).	Check the called number.
08	Quality	The document that you have transmitted has not been received correctly.	Contact your correspondent to check whether it is necessary to retransmit the document: the interference may have occurred in an unimportant area of the document.

**Table 1:**

0A	No document to recover	You have attempted to recover a document from a correspondent, but the latter has not stored the document or the password that was entered is wrong.	Contact your correspondent to check whether the document to recover has been stored or to check the validity of the password.
0B	Wrong number of pages	There is a difference between the number of pages indicated when the document was stored for transmission and the number of pages actually transmitted.	Check the number of pages of the document.
0C	Received document faulty.	The document is too long to be received in its entirety.	Ask the correspondent to check/reduce the length of his document.
0D	Document transmission fault	Document reception error.	Ask the correspondent to retransmit his document.
13	Memory full	The machine memory is full (there are too many documents that have been received but not yet printed, or waiting to be transmitted).	Print the received documents. Delete or transmit in immediate mode the documents waiting to be transmitted.
14	Memory full	Received document memory saturated.	Print the received documents.
16	List number x not retransmitted	Failure to retransmit a document via a remote fax (the requested list of recipients is not programmed on the remote fax).	Check that the list of recipients is programmed on the remote fax.
19	Stopped by correspondent	Communication stopped by your correspondent (Example: a machine attempts to recover a document from your machine, and there is no document waiting for this correspondent).	
1A	Disconnect	Transmission has not started (the phone line is too noisy).	Check the quality of the phone line or restart the transmission at a later time.

**Table 1:**

1B	Document transmission fault	Document transmission error.	Transmission: restart the transmission. Reception: ask your correspondent to retransmit the document.
----	-----------------------------	------------------------------	---

## RAP 2 Jam Detection

### Jam 1. Paper jam at the paper cassette

When the registration sensor does not turn on within 2.52 seconds after the paper pick-up clutch for the paper cassette turns on.

### Jam 2. Paper did not pass the registration sensor

When the registration sensor does not turn off within the specified time for passing each paper size (see below) + 3 seconds after the registration sensor turns on.

**Table 2:**

Paper Size	A4SEF	A5SEF	A5LEF	A6SEF	B5SEF	B6SEF	Letter SEF	Legal SEF	Envelope (91x191mm)
Specified Time (msec)	2555	1807	1273	1273	2211	1566	2400	3059	1643

### Jam 3. Paper did not reach the fusing unit

When the paper exit sensor does not turn on within 1.94 seconds after the registration sensor turns on.

### Jam 4. Paper jam in the fusing exit area

When the paper exit sensor does not turn off within 2.99 seconds after the registration sensor turns off.

### Jam 5. Paper no feed jam in the bypass tray

When the registration sensor does not turn on within 1.72 seconds after the main motor starts.



### 3 Image Quality

IQ 1 Checking the quality of Prints and Tuning the Scanner ..... [3-3](#)

This page is intentionally blank

## **IQ 1 Checking the Quality of Prints and Calibrating the Scanner**

To check or improve the quality of prints, you should first calibrate the scanner. Follow this procedure:

1. Press **▼** enter **\*** then **A** on the keyboard and confirm with **OK**. The machine reboots.
2. Start making copies of documents on the document glass and check the quality of the copies.

If the problem persists and if it is related to the scanner:

- Repeat the calibration procedure (step **1**). If the problem persists and if it is related to the printer (the scanner still provides unsatisfactory results):
  1. Press **▼** then enter **56** on the keyboard. The machine prints the list of printer parameters.
  2. Check the printer's printing and copying parameters.
  3. Check the print cartridge.

This page is intentionally blank

## 4 Repairs and Adjustments

REP 1 Control Panel .....	<a href="#">4-3</a>
REP 2 ADF Cover and Document Pad .....	<a href="#">4-5</a>
REP 3 Front Door and Side Cover .....	<a href="#">4-10</a>
REP 4 Feeder Assembly .....	<a href="#">4-13</a>
REP 5 Retard Pad and Cork Pad .....	<a href="#">4-15</a>
REP 6 ADF Document Feed Assembly .....	<a href="#">4-17</a>
REP 7 Upper Paper Guide Assembly .....	<a href="#">4-20</a>
REP 8 Motor Frame .....	<a href="#">4-22</a>
REP 9 ADF Feed Guide / Registration Roll / Paper Deflector .....	<a href="#">4-25</a>
REP 10 ADF Sliders and Antistatic Brush .....	<a href="#">4-28</a>
REP 11 CPU Module .....	<a href="#">4-30</a>
REP 12 Speaker .....	<a href="#">4-33</a>
REP 13 Back Cover .....	<a href="#">4-35</a>
REP 14 Output Tray Assembly .....	<a href="#">4-37</a>
REP 15 Machine Disassembly .....	<a href="#">4-39</a>
REP 16 Scanner Assembly .....	<a href="#">4-40</a>
REP 17 Power Supply Unit .....	<a href="#">4-43</a>
REP 18 Scanner Frame .....	<a href="#">4-44</a>
REP 19 CIS .....	<a href="#">4-46</a>
REP 20 CIS Ribbon Cable .....	<a href="#">4-48</a>
REP 21 CIS Support .....	<a href="#">4-50</a>
REP 22 Scanner Motor .....	<a href="#">4-52</a>
REP 23 Paper Tray Components .....	<a href="#">4-54</a>
REP 24 Laser Unit .....	<a href="#">4-58</a>
REP 25 Fusing Unit .....	<a href="#">4-61</a>
REP 26 Paper Exit Assembly .....	<a href="#">4-63</a>
REP 27 Fusing Lamp and Heat Roller .....	<a href="#">4-65</a>
REP 28 Pressure Roller .....	<a href="#">4-70</a>
REP 29 Thermistor .....	<a href="#">4-73</a>
REP 30 Thermostat .....	<a href="#">4-74</a>
REP 31 Heat Roller Stripper Fingers .....	<a href="#">4-76</a>
REP 32 Paper Feed Roller .....	<a href="#">4-78</a>
REP 33 Registration Roller .....	<a href="#">4-81</a>
REP 34 Transfer Roller .....	<a href="#">4-84</a>
REP 35 Fan Assembly .....	<a href="#">4-86</a>
REP 36 Main Motor .....	<a href="#">4-87</a>
REP 37 Discharge Lamp Assembly .....	<a href="#">4-89</a>
REP 38 Scanner Cover and Document Pad .....	<a href="#">4-91</a>

This page is intentionally blank

## REP 1 Control Panel

Parts List on: [PL 1](#)

### WARNING

Switch off the electricity to the machine. Disconnect the power cord from the customer supply while performing tasks that do not need electricity. Electricity can cause death or injury. Moving parts can cause injury.

### Preparation

- None.

### Removal

1. Unlock the three clips of the front panel (**A**, **B** and **C**), Figure 1.

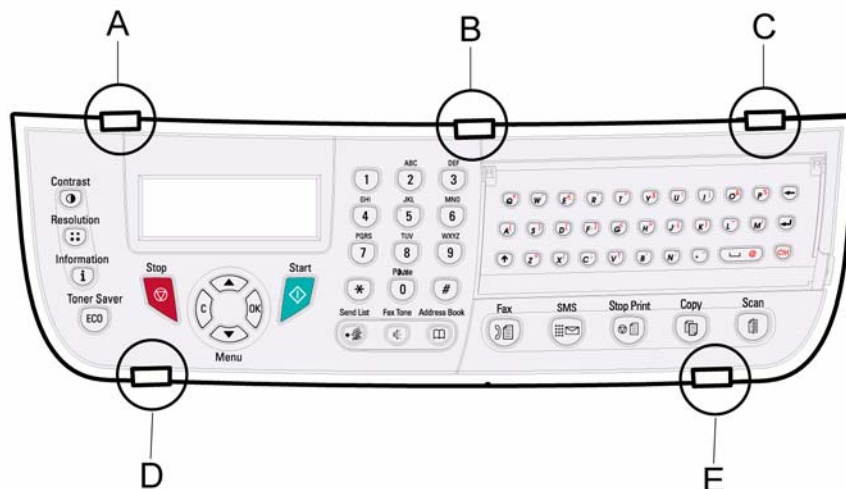

**Figure 1 (3100 MFP/X shown, 3100 MFP/S similar)**

2. Pull the panel forward to release it from the two bottom slots (**D** and **E**).

3. Disconnect the ribbon cable from the control panel board, Figure 2.



**Figure 2**

4. Remove the control panel.

### **Replacement**

1. Replacement is the reverse of the removal procedure.



## REP 2 ADF Cover and Document Pad

Parts List on: [PL 7](#)

### WARNING

Switch off the electricity to the machine. Disconnect the power cord from the customer supply while performing tasks that do not need electricity. Electricity can cause death or injury. Moving parts can cause injury.

### Preparation

- None.

### Removal

#### Document Pad:

1. Raise the ADF.
2. Remove the document pad located on the underside of the ADF, Figure 1.



Figure 1

**ADF Cover:**

1. Close the ADF and open the ADF cover assembly, Figure 2.



**Figure 2**

2. Remove the ADF motor cover from its two slots using a flat screwdriver then remove the ADF motor cover, Figure 3.

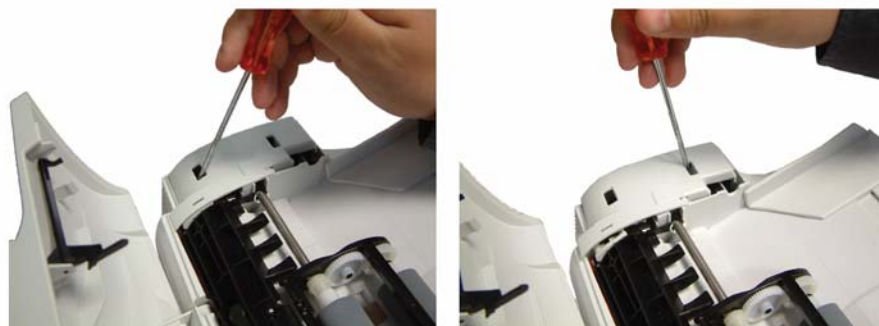

**Figure 3**

3. Unscrew the mounting screw of the ground cable, Figure 4.

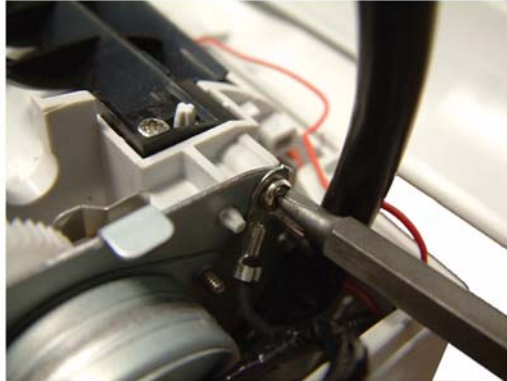

**Figure 4**

4. Disconnect the ADF cover sensor connector (A) and the paper sensor connector (B), Figure 5.

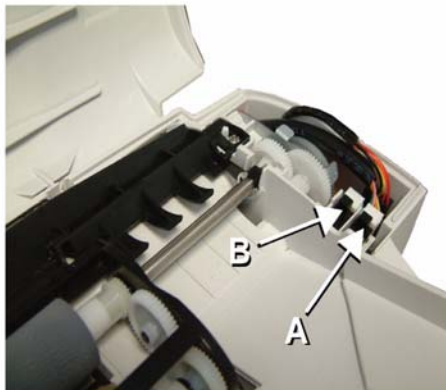

**Figure 5**

5. Open the ADF cover, unscrew the two mounting screws of the cable cover and remove the cable cover, Figure 6.

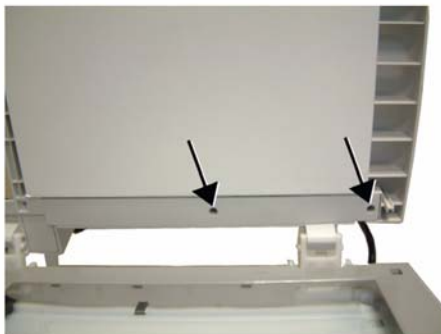

**Figure 6**

6. Remove the ground cable, the ADF cover sensor connector and the paper sensor connector from their cable guide then slide them out of the ADF cover, Figure 7.

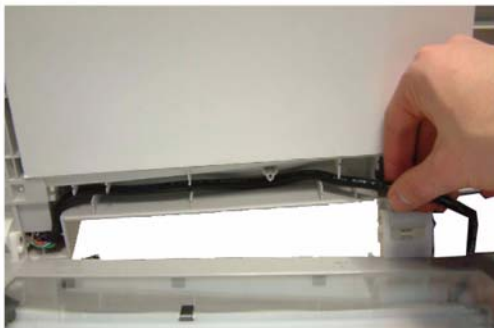

**Figure 7**

7. Insert a flat screwdriver in each slot of the two ADF cover hinges, Figure 8.



**Figure 8**

8. Lift and remove the ADF cover, do not forget the mounting screws of the hinges, Figure 9.

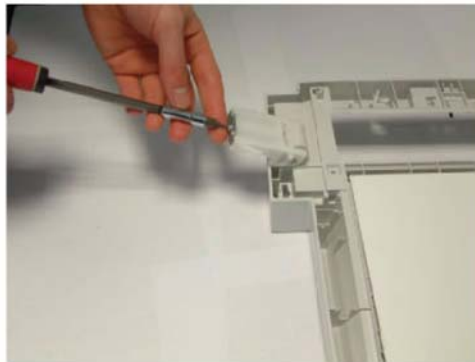

**Figure 9**

## Replacement

1. Replacement is the reverse of the removal procedure.

## REP 3 Front Door and Side Cover

Parts List on: [PL 2](#)

### WARNING

Switch off the electricity to the machine. Disconnect the power cord from the customer supply while performing tasks that do not need electricity. Electricity can cause death or injury. Moving parts can cause injury.

### Preparation

- None.

### Removal

#### Front Door:

1. Push the left and right side of the printer front door and simultaneously pull it forward.
2. Move the arms away from each other and remove the printer front door, Figure 1.

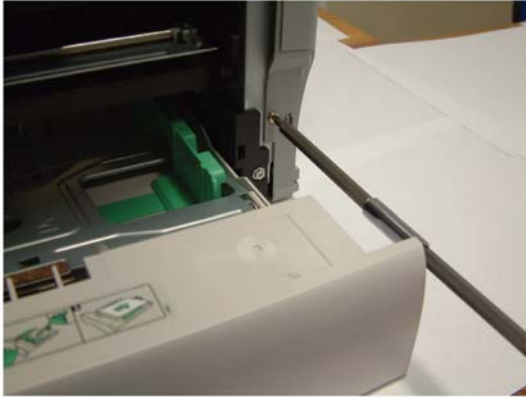

Figure 1

#### Side Covers:

1. Open the printer's paper tray.

2. Unscrew the two mounting screws on the front and back of the side covers, front mounting screw of the right hand side cover, back mounting screw of the right-hand side cover, Figure 2.



**Figure 2**

3. Using a flat screwdriver, release the tabs under the covers from their slots, Figure 3.



**Figure 3**

4. Unclip the side covers from the top slots located at the back of the machine and pivot them towards yourself to remove them, Figure 4.



**Figure 4**

5. Remove the side covers.

### **Replacement**

1. Replacement is the reverse of the removal procedure.



## REP 4 Feeder Assembly

Parts List on: [PL 8](#)

### WARNING

Switch off the electricity to the machine. Disconnect the power cord from the customer supply while performing tasks that do not need electricity. Electricity can cause death or injury. Moving parts can cause injury.

### Preparation

- None.

### Removal

1. Open the ADF cover, Figure 1.

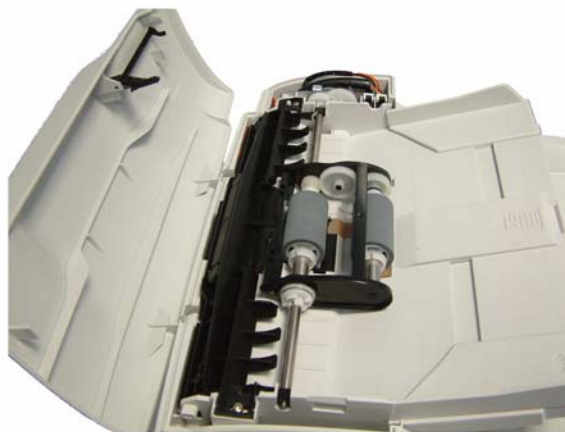

**Figure 1**

2. Remove the ADF motor cover, refer to [REP 2](#).

3. Lift the roller bearing, Figure 2.



**Figure 2**

4. Lift the roller bearing from the other end of the feeder, Figure 3.

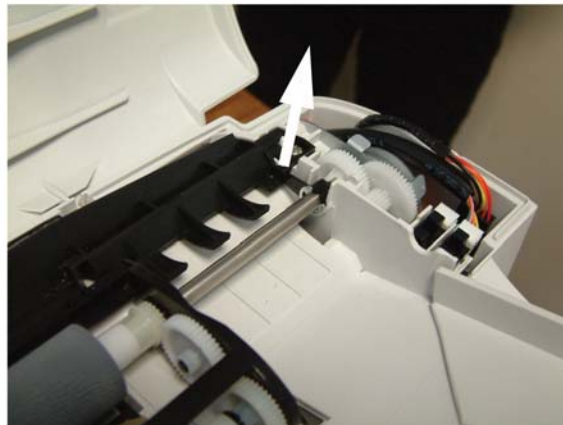

**Figure 3**

5. Lift the feeder and remove the feeder.

## Replacement

1. Replacement is the reverse of the removal procedure.

## REP 5 Retard Pad and Cork Pad

Parts List on: [PL 8](#)

### WARNING

Switch off the electricity to the machine. Disconnect the power cord from the customer supply while performing tasks that do not need electricity. Electricity can cause death or injury. Moving parts can cause injury.

### Preparation

- Remove the feeder assembly, [REP 4](#).

### Removal

#### Rocking Plate:

1. Insert a screwdriver in the right slot as shown below and make a pivoting movement downwards without strain to remove the retard pad.
2. Repeat the previous step for the left slot of the retard pad, Figure 1.

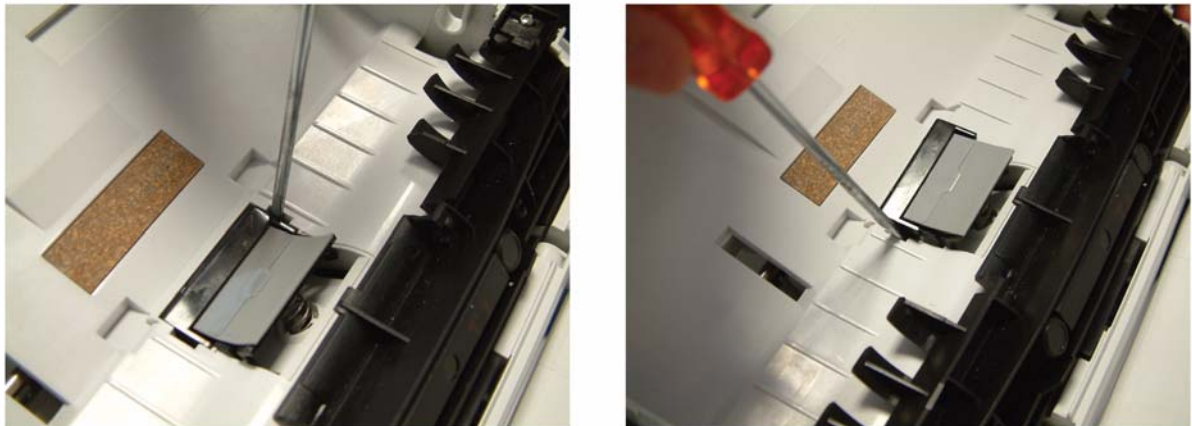
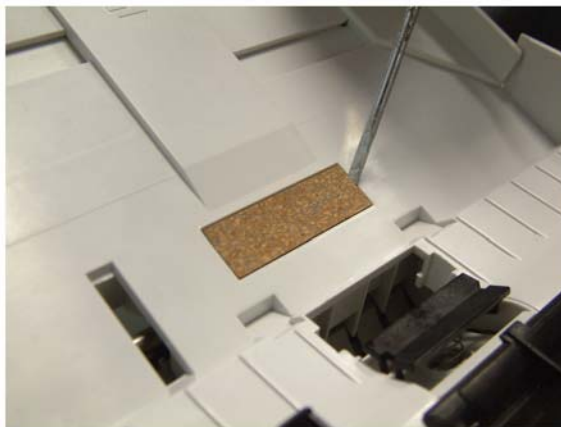

Figure 1

3. Remove the feed roll assembly.

### Cork Dad:

4. Insert a screwdriver in the right slot as shown below and make a pivoting movement downwards without strain to remove the cork pad, Figure 2.



**Figure 2**

## Replacement

### Cork Pad

1. Make sure that the slot of the cork on the paper input guide is clean.
2. Replacement is the reverse of the removal procedure.

### Retard Pad Assembly:

1. Replacement is the reverse of the removal procedure.

## REP 6 ADF Document Feed Assembly

Parts List on: [PL 7](#)

### WARNING

Switch off the electricity to the machine. Disconnect the power cord from the customer supply while performing tasks that do not need electricity. Electricity can cause death or injury. Moving parts can cause injury.

### Preparation

None.

### Removal

1. Lift the ADF cover and unscrew the two mounting screws of the document feed assembly, Figure 3.



Figure 3

2. Lift the document feed assembly and remove it from its slot without disassembling it, Figure 4.

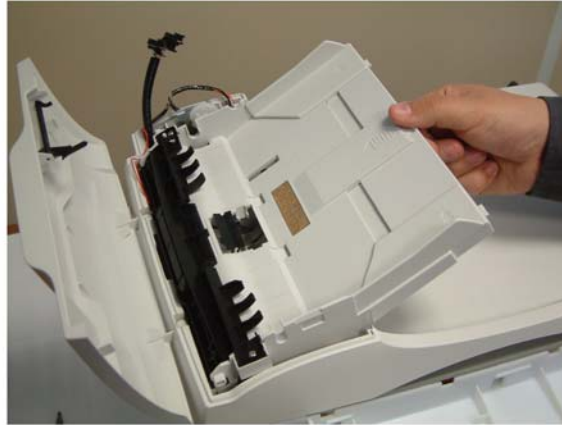

**Figure 4**

3. Remove the motor frame cable from its cable guide, Figure 5.



**Figure 5**

4. Disconnect the connector to the ADF cover and remove the assembly, Figure 6.

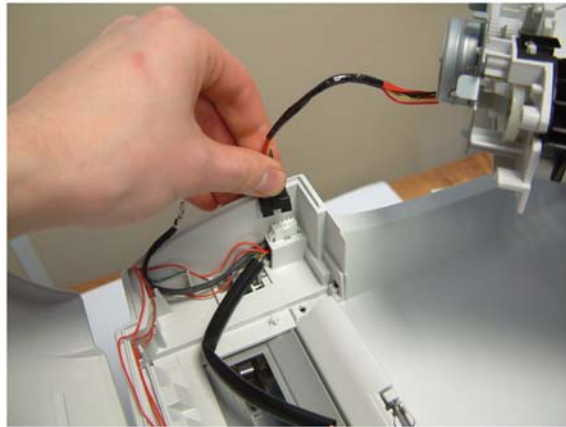

**Figure 6**

## **Replacement**

1. Replacement is the reverse of the removal procedure.

## REP 7 Upper Paper Guide Assembly

Parts List on: [PL 8](#)

### WARNING

Switch off the electricity to the machine. Disconnect the power cord from the customer supply while performing tasks that do not need electricity. Electricity can cause death or injury. Moving parts can cause injury.

### Preparation

- Remove the feeder assembly, [REP 4](#).

### Removal

1. Open the ADF cover.
2. Unscrew the two mounting screws of the paper guide assembly, Figure 1.



Figure 1



3. Pull out the paper guide assembly, Figure 2.

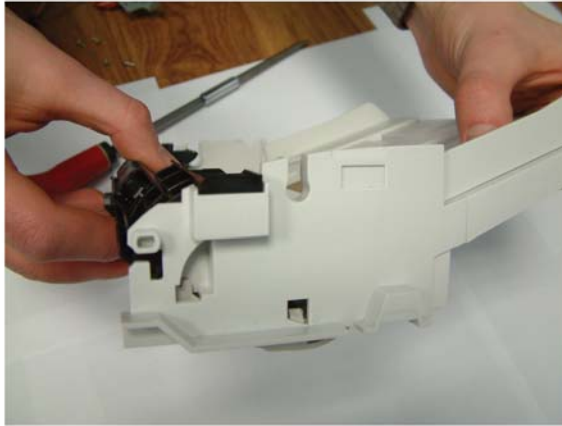

**Figure 2**

## **Replacement**

1. Replacement is the reverse of the removal procedure.

## REP 8 Motor Frame

Parts List on: [PL 8](#)

### WARNING

Switch off the electricity to the machine. Disconnect the power cord from the customer supply while performing tasks that do not need electricity. Electricity can cause death or injury. Moving parts can cause injury.

### Preparation

- Remove the feeder assembly, [REP 4](#).
- Remove the document feed assembly, [REP 6](#).

### Removal

1. Unscrew the mounting screw of the motor frame, Figure 1.

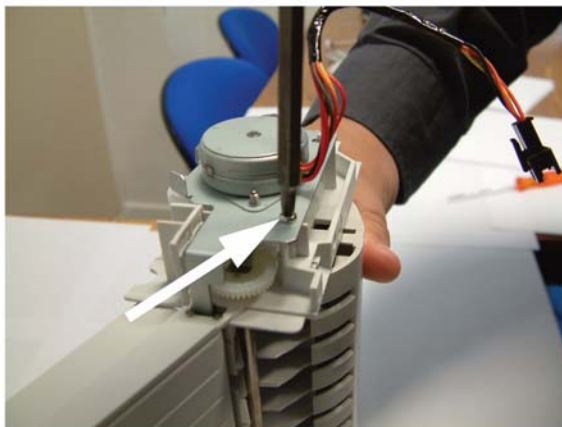
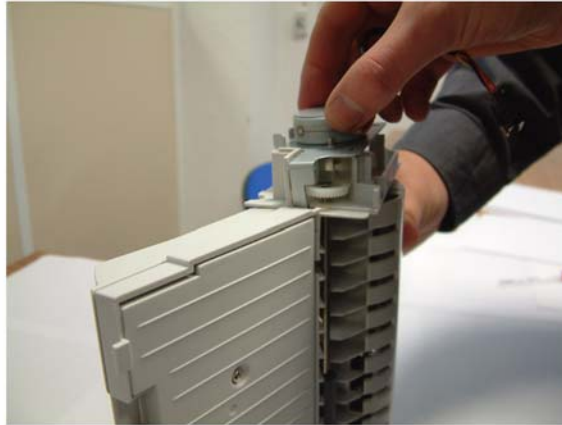

Figure 1

2. Lift and remove the motor frame. Take note of the location of the teeth gears, then remove them, Figure 2.



**Figure 2**

3. If required unscrew the two mounting screws of the motor and remove the motor, Figure 3.

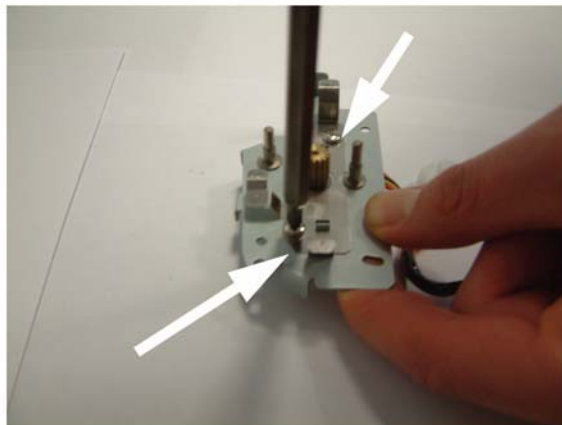

**Figure 3**

## Replacement

1. Replacement is the reverse of the removal procedure.
2. Position the teeth gears respecting their location identified during disassembly, Figure 4.

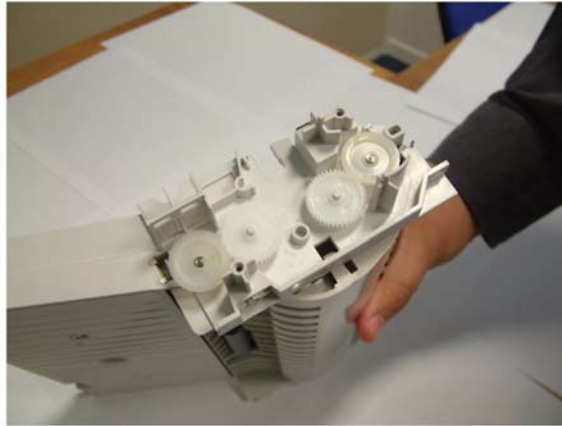

**Figure 4**

## REP 9 ADF Feed Guide / Registration Roll / Paper Deflector

Parts List on: [PL 9](#)

### WARNING

Switch off the electricity to the machine. Disconnect the power cord from the customer supply while performing tasks that do not need electricity. Electricity can cause death or injury. Moving parts can cause injury.

### Preparation

- Remove the feeder assembly, [REP 4](#).
- Remove the ADF document feed assembly, [REP 6](#)
- Remove the motor frame [REP 8](#).

### Removal

#### ADF Feed Guide

1. Turn the assembly upside down.
2. Lift the ADF feed guide to remove it from the ADF document feed assembly, Figure 1.

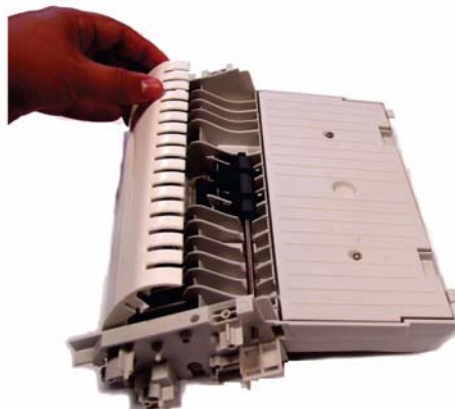

Figure 1

### Paper Deflector

3. Turn the ADF assembly upside down.
4. Unclip the paper deflector and remove it.

### Registration Roller

5. Turn the assembly upside down.
6. Turn each roller bearing of the registration roller, Figure 2.

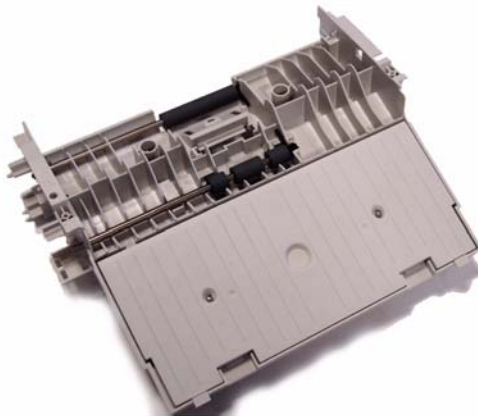

**Figure 2**

7. Remove the E-clip, bearing, gear then the registration roller.

## Replacement

### ADF Feed Guide

1. Replacement is the reverse of the removal procedure.

### Paper Deflector

2. Position the paper deflector on the registration roller and press to clip it in place, Figure 3.

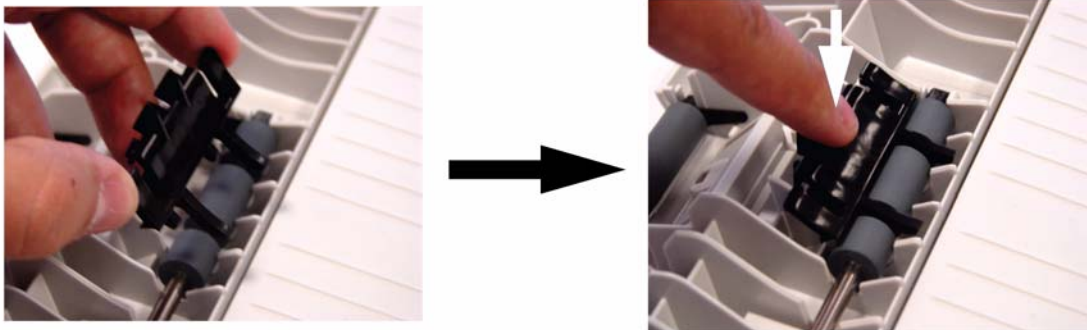

Figure 3

### Registration Roller

3. Replacement is the reverse of the removal procedure.

## REP 10 ADF Sliders and Antistatic Brush

Parts List on: [PL 8](#), [PL 9](#)

### WARNING

Switch off the electricity to the machine. Disconnect the power cord from the customer supply while performing tasks that do not need electricity. Electricity can cause death or injury. Moving parts can cause injury.

### Preparation

- Remove the feeder assembly, [REP 4](#).
- Remove the ADF document feed assembly, [REP 6](#)
- Remove the motor frame [REP 8](#).

### Removal

1. Turn the assembly upside down.
2. Remove the 2 mounting screws of the lower cover and remove it, Figure 1.

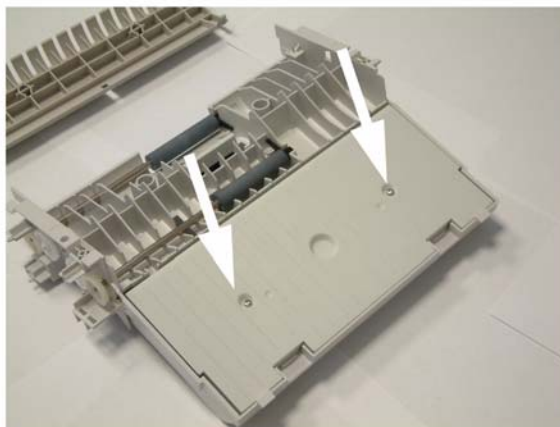
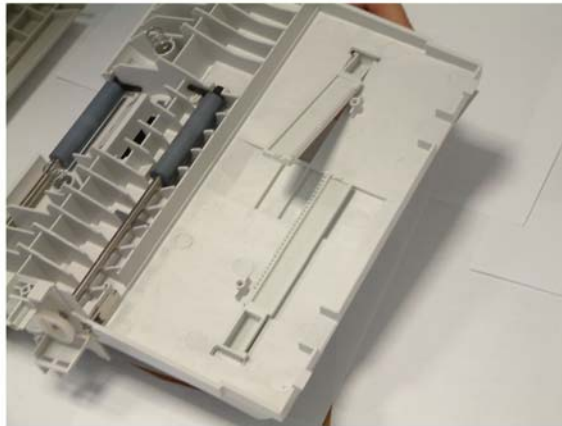

Figure 1



3. Lift the rack gears and remove them from the input tray assembly, Figure 2.



**Figure 2**

4. Carefully remove the antistatic brush, Figure 3.

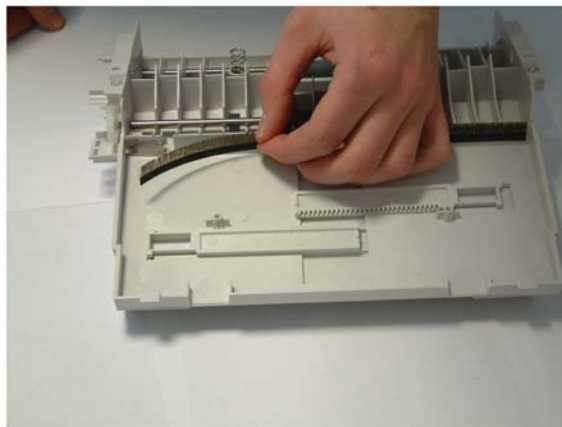

**Figure 3**

## Replacement

1. Replacement is the reverse of the removal procedure.
2. Check that the slot of the antistatic brush is clean. Position the antistatic brush in its slot and press on the lower part to make sure the adhesives are strongly fixed.

## REP 11 CPU Module

Parts List on: [PL 2](#)

### WARNING

Switch off the electricity to the machine. Disconnect the power cord from the customer supply while performing tasks that do not need electricity. Electricity can cause death or injury. Moving parts can cause injury.

### Preparation

- Print the machine's parameters (user, administrator and technical) and the activity counter values in order to keep a record (▼ **5 6**). You can also store user parameters and directory entries on a smart card (▼ \* **6**) and restore them (▼ \* **9**) after the machine is serviced.
- Remove the printer front door assembly and the right side cover, [REP 3](#).

### Removal

1. Unscrew the three mounting screws of the CPU board shield plate, Figure 1.



**Figure 1**

2. Pull the CPU board shield plate forwards and remove it.

3. Unscrew the mounting screw of the CPU card ground connector and disconnect it, Figure 2.



**Figure 2**

4. Disconnect all connectors from the CPU board.

**CAUTION**

*Note all connections for reassembly.*

5. Unscrew the eight mounting screws and remove the CPU board, Figure 3.



**Figure 3**

## Replacement

1. Replacement is the reverse of the removal procedure.
2. Connect all connectors to the CPU board, Figure 4.

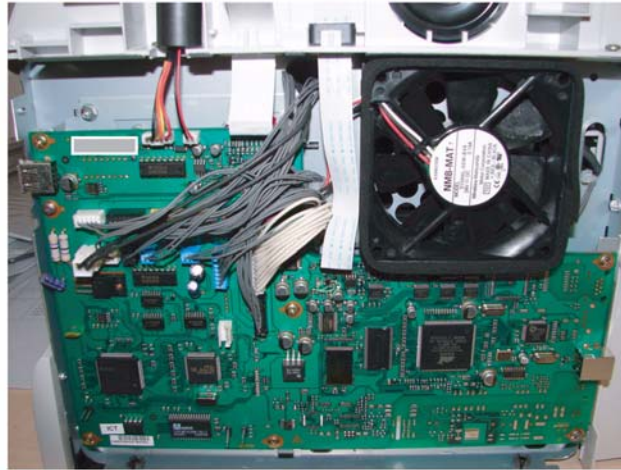

**Figure 4**

3. Perform the scanner calibration (▼ 8 0).

## REP 12 Speaker

Parts List on: [PL 2](#)

### WARNING

Switch off the electricity to the machine. Disconnect the power cord from the customer supply while performing tasks that do not need electricity. Electricity can cause death or injury. Moving parts can cause injury.

### Preparation

- Remove the printer front door assembly and the right side cover, [REP 3](#).
- Remove the CPU shield plate, [REP 11](#).

### Removal

1. Disconnect the speaker connector from the CPU board.

### CAUTION

*Before removing the speaker harness from the ferrite tube make a note of the routing.*

2. Remove the speaker connector from its ferrite tube and cable guide, Figure 1.

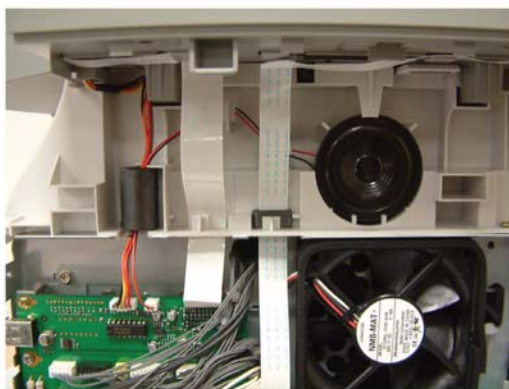
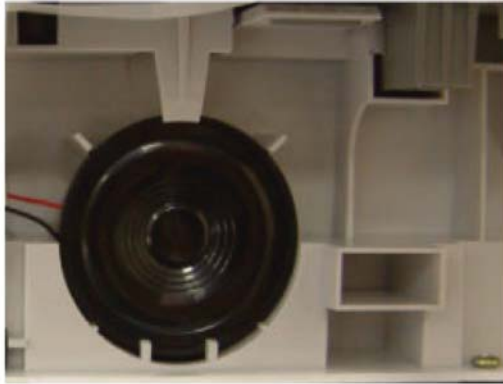

Figure 1

3. Press the top clip inwards until it unclips and pull out the speaker, Figure 2.



**Figure 2**

### **Replacement**

1. Replacement is the reverse of the removal procedure.

## REP 13 Back Cover

Parts List on: [PL 3](#)

### WARNING

Switch off the electricity to the machine. Disconnect the power cord from the customer supply while performing tasks that do not need electricity. Electricity can cause death or injury. Moving parts can cause injury.

### Preparation

- Remove the ADF cover, [REP 2](#).
- Remove the printer front door and the side covers, [REP 3](#).
- Remove the CPU shield plate, refer to [REP 11](#).
- Remove the platen assembly, [REP 16](#).

### Removal

1. Unscrew the two back mounting screws on the back cover (A and B), Figure 1.

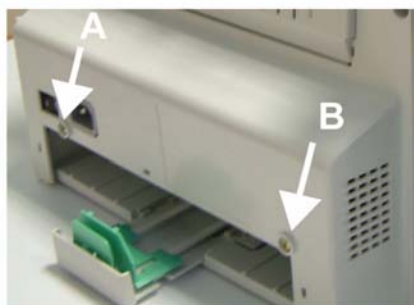

Figure 1

2. Unscrew the two top mounting screws on the back cover (C and D), Figure 2.



**Figure 2**

3. Pull the back cover and remove it.

### **Replacement**

1. Replacement is the reverse of the removal procedure.



## REP 14 Output Tray Assembly

Parts List on: [PL 3](#)

### WARNING

Switch off the electricity to the machine. Disconnect the power cord from the customer supply while performing tasks that do not need electricity. Electricity can cause death or injury. Moving parts can cause injury.

### Preparation

- Remove the ADF cover, [REP 2](#).
- Remove the front door and the side covers, [REP 3](#).
- Remove the CPU shield plate, [REP 11](#).
- Remove the speaker, [REP 12](#).
- Remove the platen assembly, [REP 16](#).
- Remove the back cover, [REP 13](#).

### Removal

1. Unscrew the two mounting screws on the left and right side on the output tray assembly, Figure 1.



Figure 1

2. Lift and remove the output tray assembly, Figure 2.

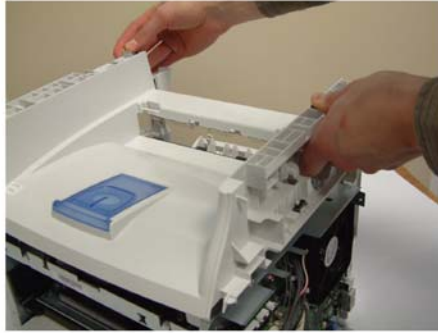

**Figure 2**

### **Replacement**

1. Replacement is the reverse of the removal procedure.

## REP 15 Machine Disassembly

Parts List on: [PL 2](#)

### WARNING

Switch off the electricity to the machine. Disconnect the power cord from the customer supply while performing tasks that do not need electricity. Electricity can cause death or injury. Moving parts can cause injury.

### Preparation

- None.

### Removal

1. Stand in front of the machine.
2. Remove the control panel [REP 1](#).
3. Remove the ADF cover ([REP 2](#)) or the platen cover ([REP 38](#)).
4. Remove the front door and the side covers ([REP 3](#)).
5. Remove the CPU module ([REP 11](#)) and the speaker ([REP 12](#)).
6. Remove the platen assembly ([REP 16](#)).
7. Remove the back cover ([REP 13](#)) and the output tray assembly ([REP 14](#)).

### Replacement

1. Replacement is the reverse of the removal procedure.

## REP 16 Scanner Assembly

Parts List on: [PL 2](#)

### WARNING

Switch off the electricity to the machine. Disconnect the power cord from the customer supply while performing tasks that do not need electricity. Electricity can cause death or injury. Moving parts can cause injury.

### Preparation

- Print the machine's parameters (user, administrator and technical) and the activity counter values in order to keep a record (▼ **5 6**). You can also store user parameters and directory entries on a smart card (▼ \* **6**) and restore them (▼ \* **9**) after the machine is serviced.
- Remove the printer front door and the side covers, [REP 3](#).
- Remove the CPU shield plate, [REP 11](#).

### Removal

1. Disconnect the scanner connector from the CPU board and remove it from its ferrite tube and cable guide.

### CAUTION

*Before removing the ribbon connections make a note of the correct connection positions.*

2. Disconnect the front panel ribbon cable and the CIS ribbon cable from the CPU board, Figure 1.



Panel ribbon connection

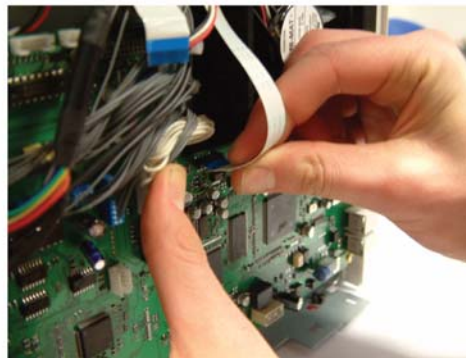

CIS ribbon connection

**Figure 1**

3. Remove the front panel and CIS ribbon cables from their cable guide, Figure 2.

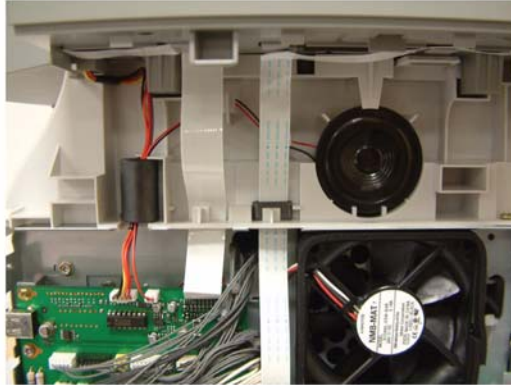

**Figure 2**

4. Use a flat head screwdriver to unhook, then remove the scanner assembly, Figure 3.

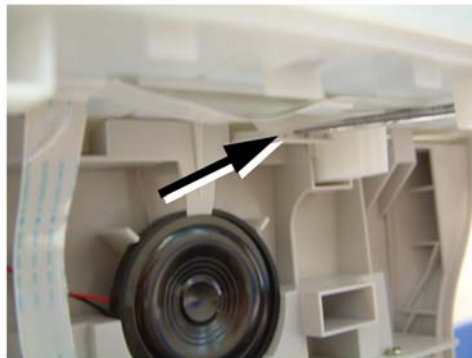

**Figure 3**

5. Lift, then remove the platen assembly, Figure 4.



**Figure 4**

### **Replacement**

1. Replacement is the reverse of the removal procedure.
2. Perform the scanner calibration (▼ **8 0**).

## REP 17 Power Supply Unit

Parts List on: [PL 13](#)

### WARNING

Switch off the electricity to the machine. Disconnect the power cord from the customer supply while performing tasks that do not need electricity. Electricity can cause death or injury. Moving parts can cause injury.

### Preparation

- Remove the print cartridge.
- Remove the paper tray.
- Remove the output tray assembly, [REP 14](#)
- Remove the right and left shield, refer to [REP 36](#)

### Removal

1. Remove the power supply unit, Figure 1.

1  
Remove 4 connectors,  
circled in blue

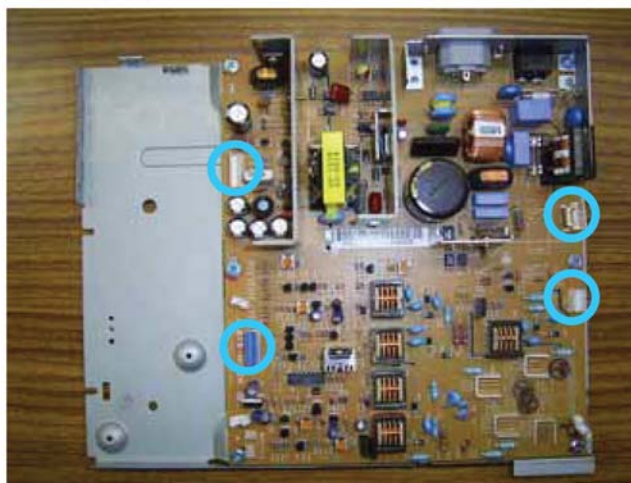

2  
Remove 9 screws to  
remove the power  
supply unit

Figure 1

### Replacement

1. Replacement is the reverse of the removal procedure.

## REP 18 Scanner Frame

Parts List on: [PL 5](#)

### WARNING

Switch off the electricity to the machine. Disconnect the power cord from the customer supply while performing tasks that do not need electricity. Electricity can cause death or injury. Moving parts can cause injury.

### Preparation

- Remove the ADF cover, [REP 2](#), or the platen cover, [REP 38](#).
- Remove the front door and the side covers, [REP 3](#).
- Remove the CPU shield plate, [REP 11](#).
- Remove the platen assembly, [REP 16](#).

### Removal

1. Remove the two mounting screws on the frame (**A** and **B**) and turn the cover upside down, Figure 1.

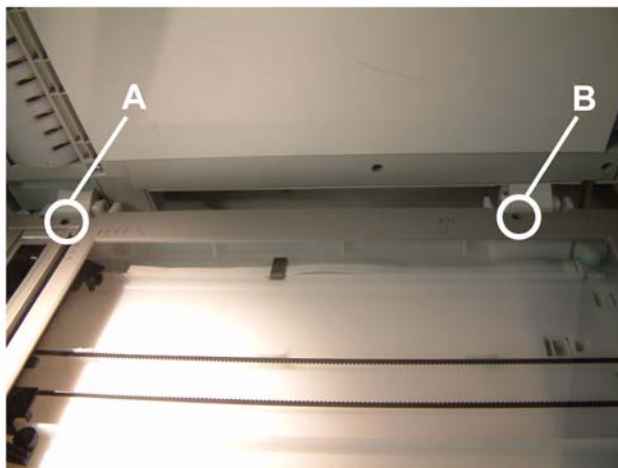
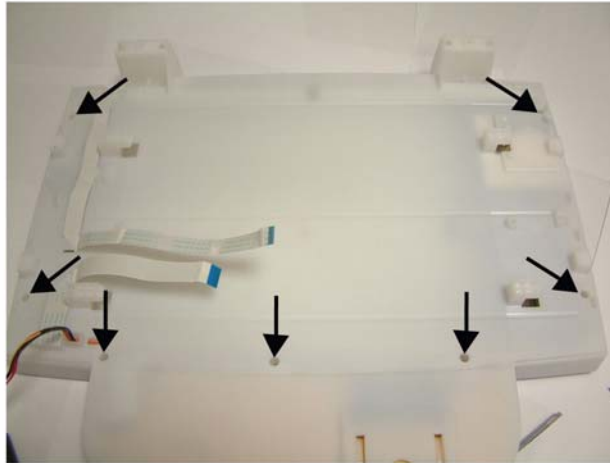

Figure 1



2. Unscrew the seven mounting screws at the back of the frame and turn it upside down, Figure 2.



**Figure 2**

3. Lift the front part of the scanner frame and remove it, Figure 3.



**Figure 3**

## Replacement

1. Replacement is the reverse of the removal procedure.

## REP 19 CIS

Parts List on: [PL 5](#)

### WARNING

Switch off the electricity to the machine. Disconnect the power cord from the customer supply while performing tasks that do not need electricity. Electricity can cause death or injury. Moving parts can cause injury.

### Preparation

- Remove the ADF cover, [REP 2](#).
- Remove the printer front door and the side covers, [REP 3](#).
- Remove the CPU armour plate, [REP 11](#).
- Remove the platen assembly, [REP 16](#).

### Removal

1. Lift the CIS backwards, Figure 1.

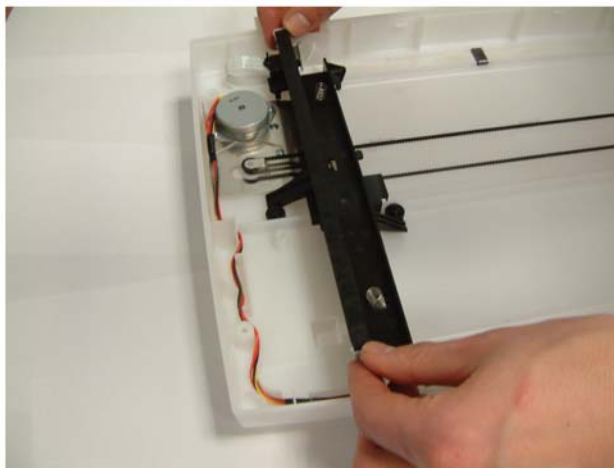
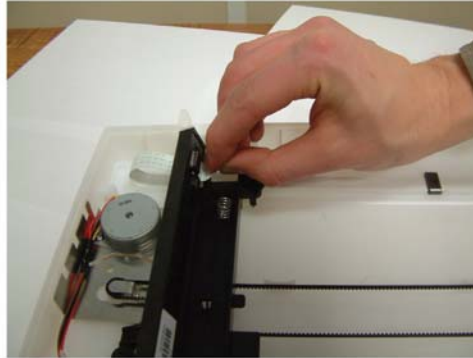

Figure 1

2. Disconnect the CIS ribbon cable and remove it from its two side slots, Figure 2.

**CAUTION**

*Keep the CIS support springs and slides.*



**Figure 2**

3. Remove the CIS.

## Replacement

1. Replacement is the reverse of the removal procedure.

## REP 20 CIS Ribbon Cable

Parts List on: [PL 6](#)

### WARNING

Switch off the electricity to the machine. Disconnect the power cord from the customer supply while performing tasks that do not need electricity. Electricity can cause death or injury. Moving parts can cause injury.

### Preparation

- Remove the ADF cover, [REP 2](#).
- Remove the front door and the side covers, [REP 3](#).
- Remove the CPU shield plate, [REP 11](#).
- Remove the platen assembly, [REP 16](#).

### Removal

1. Unfold the end of the CIS ribbon cable and remove it from its slot, Figure 1.

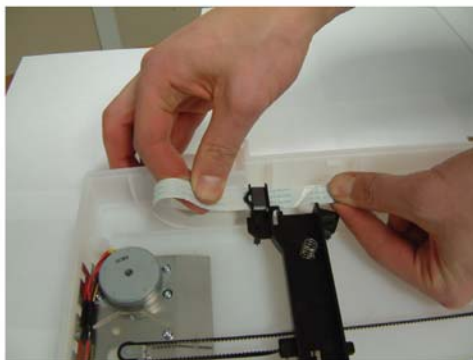

**Figure 1**

2. Slide the CIS ribbon cable out of its ferrite tube which is fixed to the CIS panel and remove it from the scanner.
3. Remove the CIS ribbon cable from its cable guides located above and below the scanner bottom then slide it to remove it from the scanner bottom.

### CAUTION

*Note the cable guide position for reassembly.*

4. Remove the CIS ribbon cable.

## Replacement

1. Replacement is the reverse of the removal procedure.

## REP 21 CIS Support

Parts List on: [PL 6](#)

### WARNING

Switch off the electricity to the machine. Disconnect the power cord from the customer supply while performing tasks that do not need electricity. Electricity can cause death or injury. Moving parts can cause injury.

### Preparation

- Remove the ADF cover, [REP 2](#).
- Remove the front door and the side covers, [REP 3](#).
- Remove the CPU shield plate, [REP 11](#).
- Remove the platen assembly, [REP 16](#).

### Removal

1. Lift the CIS drive pulley and the drive to remove the CIS drive pulley from its slot, Figure 1.



Figure 1

2. Remove the belt from the drive pulley, Figure 2.

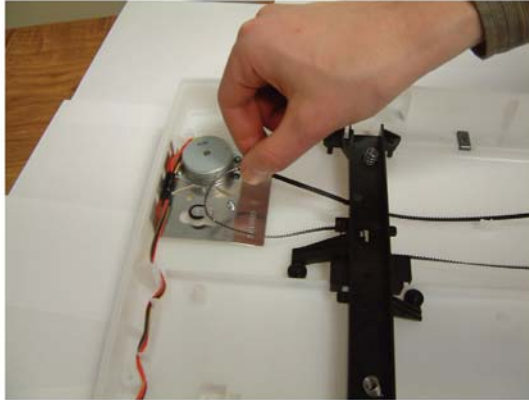

**Figure 2**

3. Lift then remove the CIS panel.

## **Replacement**

1. Replacement is the reverse of the removal procedure.

## REP 22 Scanner Motor

Parts List on: [PL 5](#)

### WARNING

Switch off the electricity to the machine. Disconnect the power cord from the customer supply while performing tasks that do not need electricity. Electricity can cause death or injury. Moving parts can cause injury.

### Preparation

- Remove the ADF cover, [REP 2](#).
- Remove the front door and the side covers, [REP 3](#).
- Remove the CPU shield plate, [REP 11](#).
- Remove the platen assembly, [REP 16](#).

### Removal

1. Unscrew the two mounting screws of the scanner motor (**A** and **B**), Figure 1.

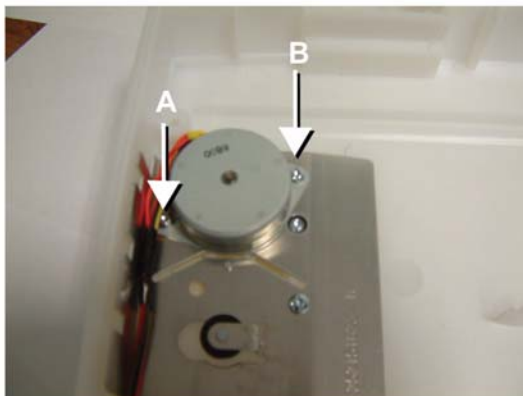
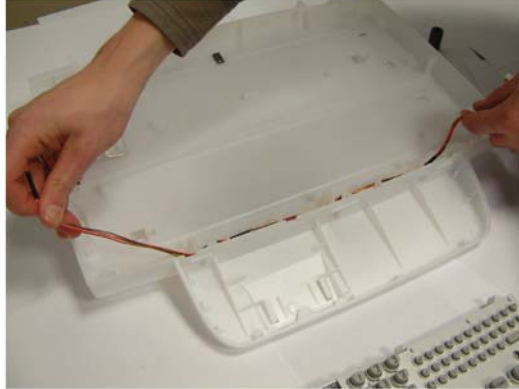

**Figure 1**

2. Remove the end of the scanner motor connector from its ferrite tube.



3. Remove the CIS motor connector from its cable guide, Figure 2.



**Figure 2**

4. Remove the scanner motor.

## **Replacement**

1. Replacement is the reverse of the removal procedure.

## REP 23 Paper Tray Components

Parts List on: [PL 10](#)

### **WARNING**

Switch off the electricity to the machine. Disconnect the power cord from the customer supply while performing tasks that do not need electricity. Electricity can cause death or injury. Moving parts can cause injury.

### **Preparation**

None.

### **Removal**

1. Remove the paper tray, Figure 1.



**Figure 1**

## Pinion Gear

2. Remove the pinion gear, Figure 2.



Figure 2

3. Unhook and lift the bottom plate, Figure 3.



**Figure 3**

4. Unhook the left pinion gear. Repeat with the right pinion gear.

**Bottom Plate**

5. Unhook the bottom plate from the pivots pins at both sides of the cassette, Figure 3.

## Friction Pad

6. Release 2 hooks from below, Figure 4.

### **CAUTION**

*When releasing the hooks take care not to lose the spring.*

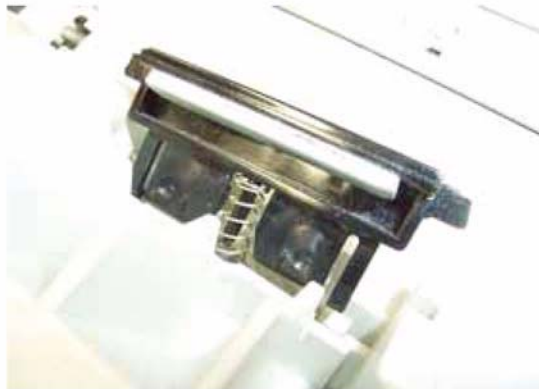

**Figure 4**

## Replacement

1. Replacement is the reverse of the removal procedure.

## REP 24 Laser Unit

Parts List on: [PL 13](#)

### WARNING

Switch off the electricity to the machine. Disconnect the power cord from the customer supply while performing tasks that do not need electricity. Electricity can cause death or injury. Moving parts can cause injury.



### WARNING

Avoid exposure to laser beam. Invisible laser radiation.

## Preparation

1. Remove the output tray assembly, [REP 14](#)

## Removal

2. Remove the laser unit, Figure 1.

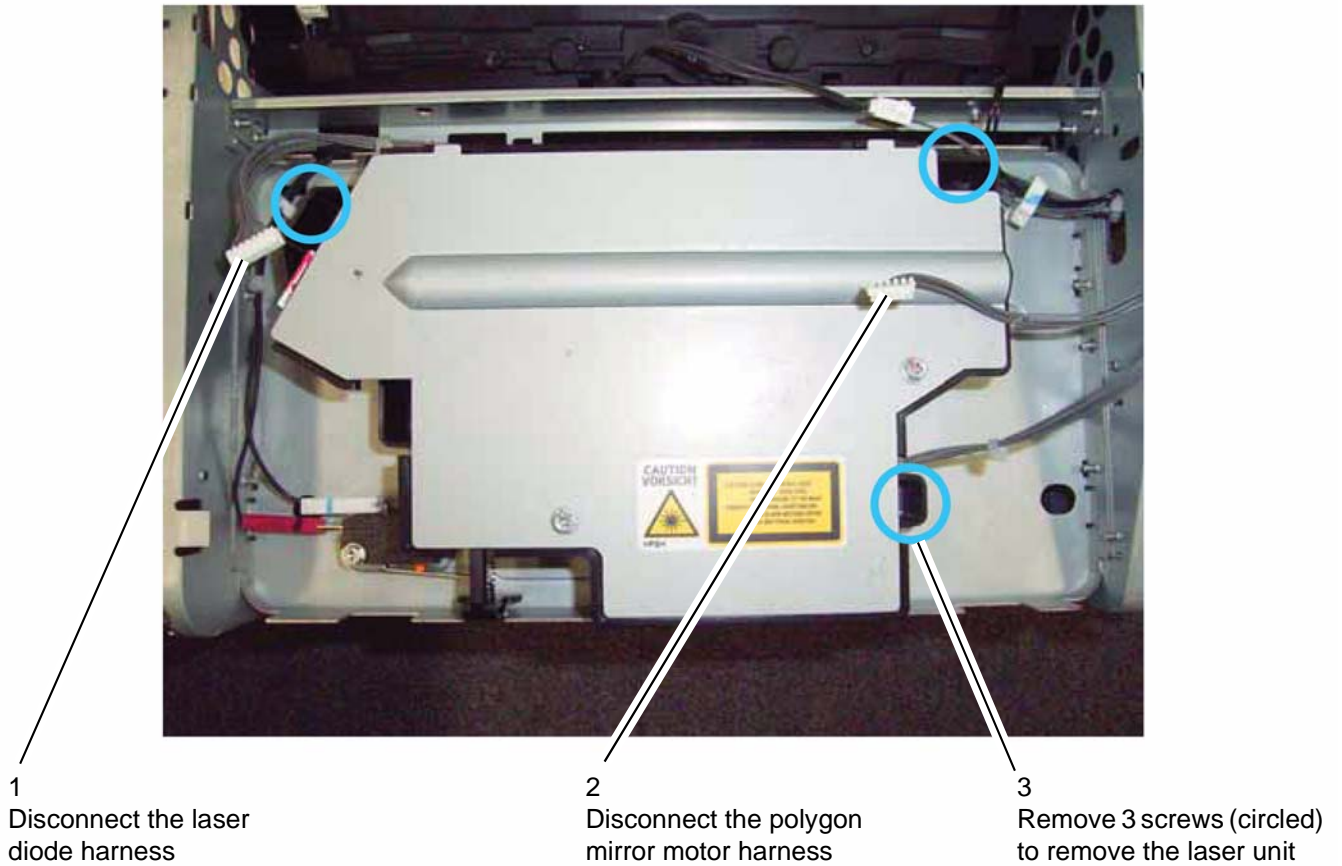

Figure 1

## Replacement

1. Replacement is the reverse of the removal procedure.
2. When reassembling, ensure to set the positioning pin in the hole, Figure 2.



**Figure 2**



## REP 25 Fusing Unit

Parts List on: [PL 12](#)

### WARNING

Switch off the electricity to the machine. Disconnect the power cord from the customer supply while performing tasks that do not need electricity. Electricity can cause death or injury. Moving parts can cause injury.

### WARNING

Do not touch the fuser while it is hot.

### Preparation

- Remove the output tray assembly, [REP 14](#)

### Removal

- Remove the fusing unit, Figure 1.

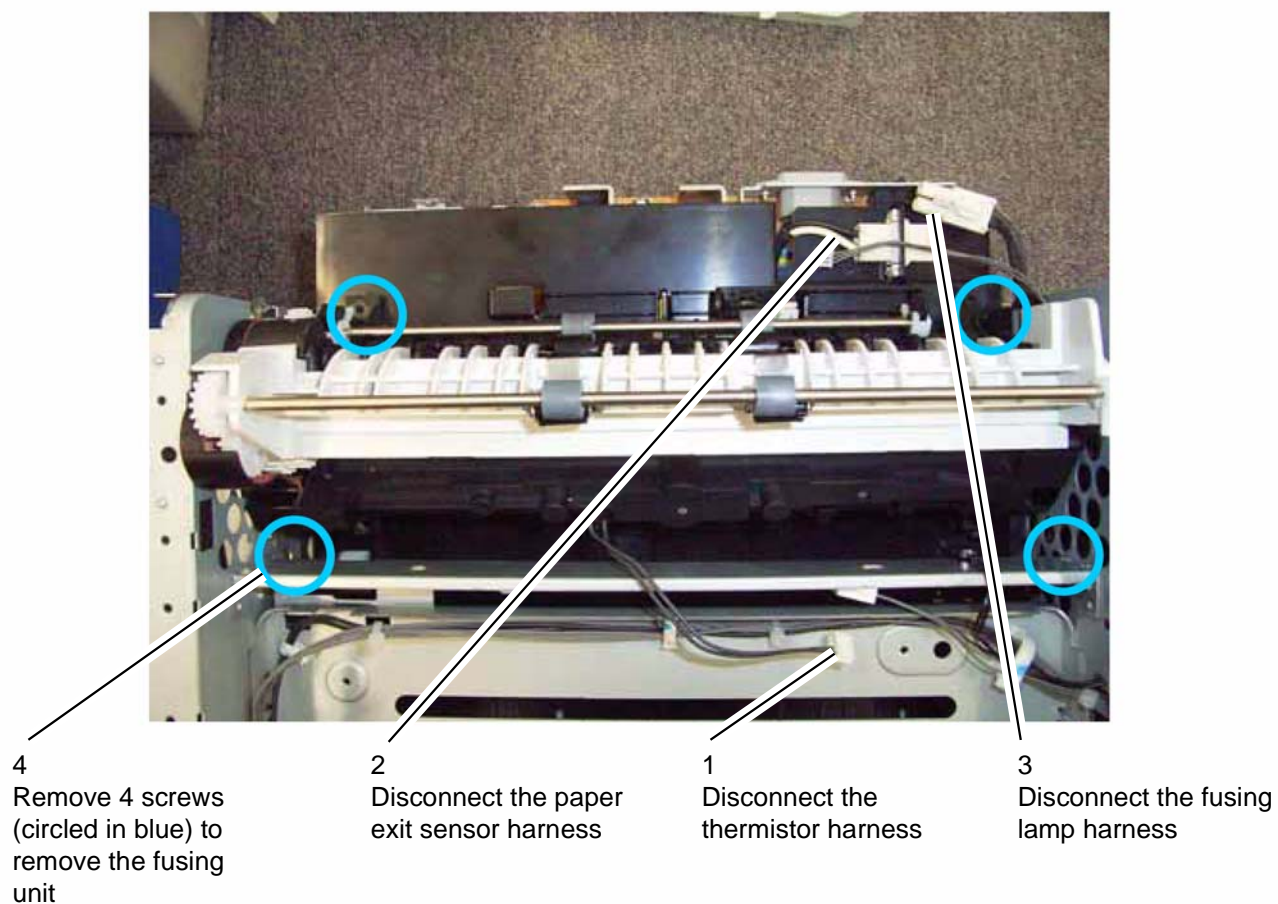

Figure 1

## Replacement

1. Replacement is the reverse of the removal procedure.

## REP 26 Paper Exit Assembly

Parts List on: [PL 12](#)

### WARNING

Switch off the electricity to the machine. Disconnect the power cord from the customer supply while performing tasks that do not need electricity. Electricity can cause death or injury. Moving parts can cause injury.

### Preparation

- Remove the fuser, [REP 25](#)

### Removal

1. Remove the end plate, Figure 1.

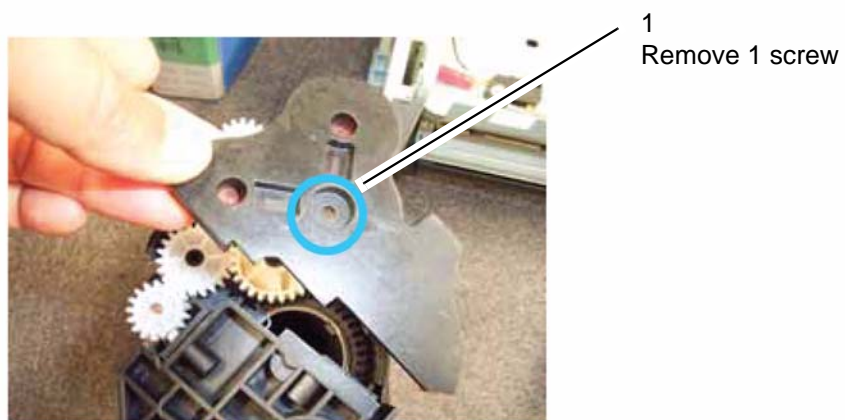
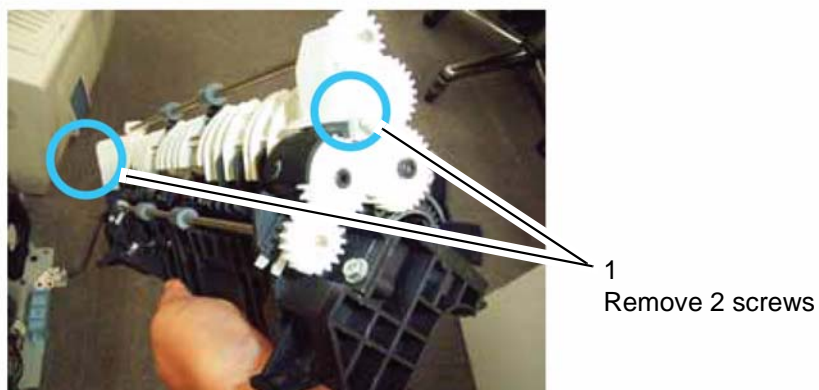

Figure 1

2. Remove 2 screws to remove the paper exit assembly, Figure 2 and Figure 3.



**Figure 2**



**Figure 3**

## Replacement

1. Replacement is the reverse of the removal procedure.

## REP 27 Fusing Lamp and Heat Roller

Parts List on: [PL 12](#)

### WARNING

Switch off the electricity to the machine. Disconnect the power cord from the customer supply while performing tasks that do not need electricity. Electricity can cause death or injury. Moving parts can cause injury.

### WARNING

Do not touch the fuser while it is hot.

### Preparation

- Remove the paper exit assembly, [REP 26](#).
- Remove the fuser, [REP 25](#)

## Removal

### Fusing Lamp

1. Release the fusing lamp, Figure 1.

#### **CAUTION**

*Do not touch the surface of the fusing lamp with bare hands. Take care when removing the lamp, it can break if not handled with care.*

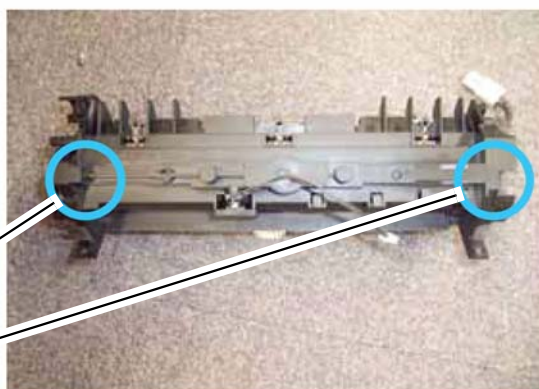

- 1  
Remove 2 screws,  
1 at each end of the fusing lamp

**Figure 1**

2. Remove the fusing lamp from the fuser, Figure 2.

1  
Carefully remove the fusing lamp by withdrawing it from the fuser



Figure 2

### Hot Roller

3. Disconnect the electrode, Figure 3.

1  
Disconnect the electrode

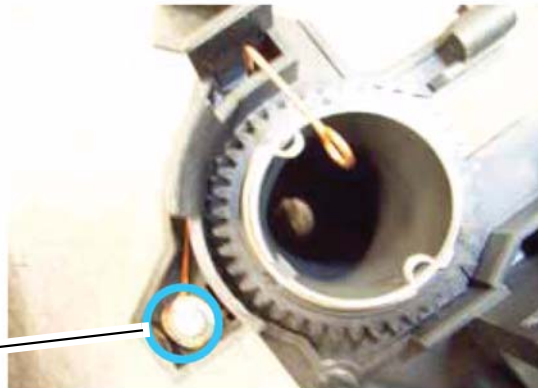

Figure 3

4. Pull the heat roller out of the fuser unit, Figure 4.

**CAUTION**

*Do not touch the surface of the heat roller with bare hands.*



**Figure 4**



## Replacement

1. Replacement is the reverse of the removal procedure.

### **CAUTION**

*When re-assembling, be careful not to damage the stripper fingers.*

2. When reassembling, be careful to set the fusing lamp on the frame first, then set the terminals, Figure 5.

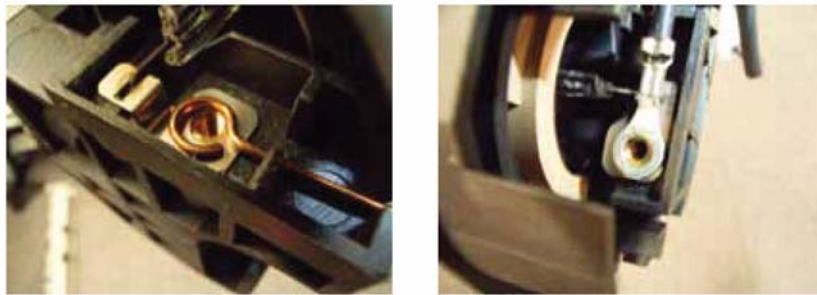

**Figure 5**

## REP 28 Pressure Roller

Parts List on: [PL 12](#)

### WARNING

Switch off the electricity to the machine. Disconnect the power cord from the customer supply while performing tasks that do not need electricity. Electricity can cause death or injury. Moving parts can cause injury.

### WARNING

Do not touch the fuser while it is hot.

### Preparation

- Remove the paper exit assembly, [REP 26](#).
- Remove the fusing lamp and hot roller, [REP 27](#).

## Removal

1. Remove the pressure roller, Figure 1.

### CAUTION

*Note the position of the bushing and spring at each end of the roller.*

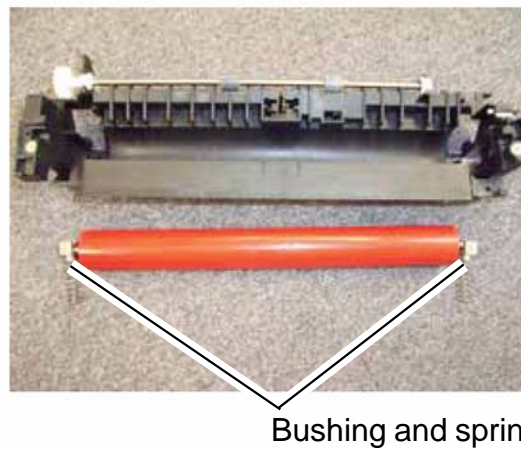
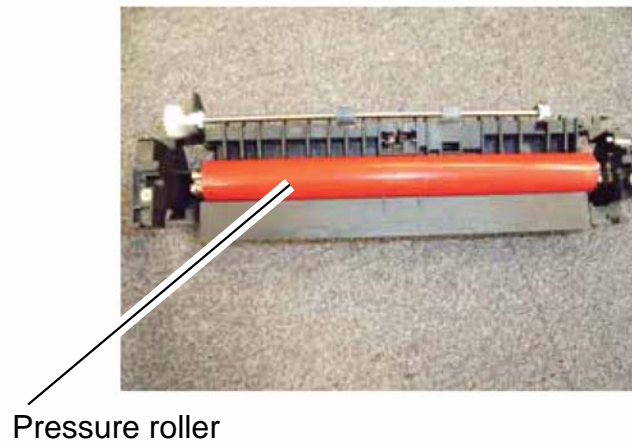

**Figure 1**

## Replacement

1. Replacement is the reverse of the removal procedure.
2. When re-assembling, be careful to set the bushing and spring in the correct position, Figure 2.

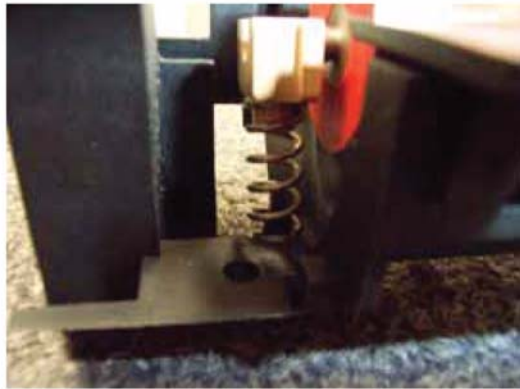

**Figure 2**

## REP 29 Thermistor

Parts List on: [PL 12](#)

### WARNING

Switch off the electricity to the machine. Disconnect the power cord from the customer supply while performing tasks that do not need electricity. Electricity can cause death or injury. Moving parts can cause injury.

### WARNING

Do not touch the fuser while it is hot.

## Preparation

- Remove the paper exit assembly, [REP 26](#).

## Removal

- Remove the thermistor, Figure 1.

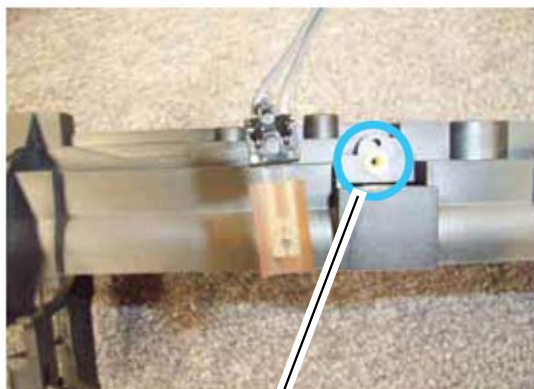

1

Remove 1 screw to remove the thermistor

## Replacement

- Replacement is the reverse of the removal procedure.

### CAUTION

*When reassembling, do not damage the thermistor, and check that the element touches the hot roller.*

## REP 30 Thermostat

Parts List on: [PL 12](#)

### WARNING

Switch off the electricity to the machine. Disconnect the power cord from the customer supply while performing tasks that do not need electricity. Electricity can cause death or injury. Moving parts can cause injury.

### WARNING

Do not touch the fuser while it is hot.

### Preparation:

- Remove the paper exit assembly, [REP 26](#).
- Remove the fusing lamp and hot roller, [REP 27](#).

### Removal

1. Remove the thermostat, Figure 1 and Figure 2.



Location of the thermostat on the fuser

Figure 1

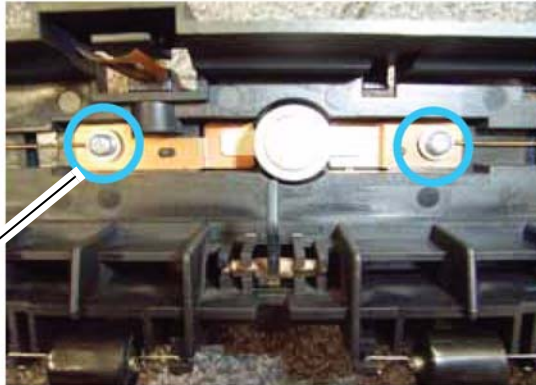

1. Remove 2 screws (circled) to remove the thermostat

**Figure 2**

## **Replacement**

1. Replacement is the reverse of the removal procedure.

## REP 31 Heat Roller Stripper Fingers

Parts List on: [PL 12](#)

### WARNING

Switch off the electricity to the machine. Disconnect the power cord from the customer supply while performing tasks that do not need electricity. Electricity can cause death or injury. Moving parts can cause injury.

### WARNING

Do not touch the fuser while it is hot.

### Preparation

- Remove the paper exit assembly, [REP 26](#).
- Remove the fusing lamp and hot roller, [REP 27](#).

### Removal

1. Identify the location of the heat roller stripper fingers, Figure 1.

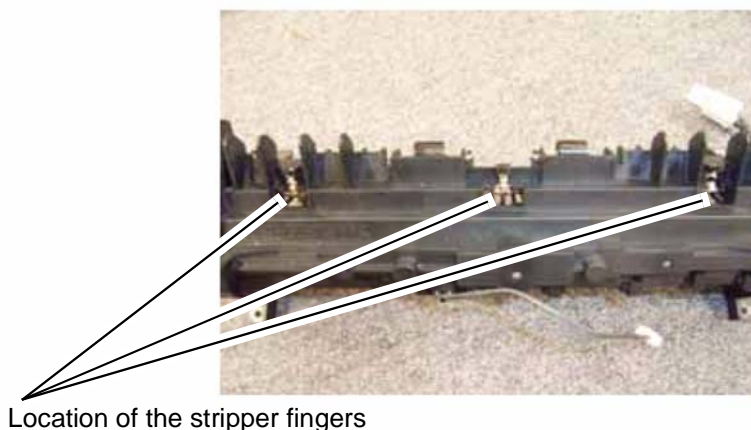

Figure 1



2. Remove the heat roller stripper fingers, Figure 2,



**Figure 2**

## **Replacement**

1. Replacement is the reverse of the removal procedure.

### **CAUTION**

*When reassembling, be careful not to lose the spring.*

## REP 32 Paper Feed Roller

Parts List on: [PL 11](#)

### WARNING

Switch off the electricity to the machine. Disconnect the power cord from the customer supply while performing tasks that do not need electricity. Electricity can cause death or injury. Moving parts can cause injury.

### Preparation

- Remove the output tray assembly, [REP 14](#)

### Removal

1. Remove the drive assembly, Figure 1.

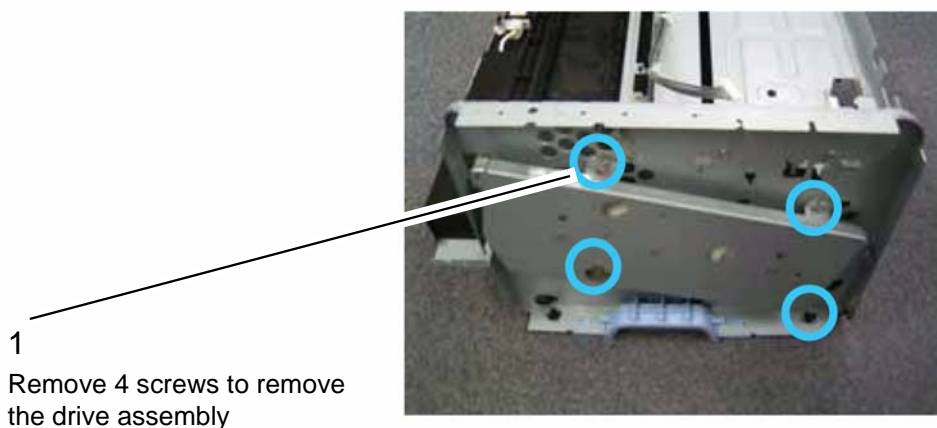
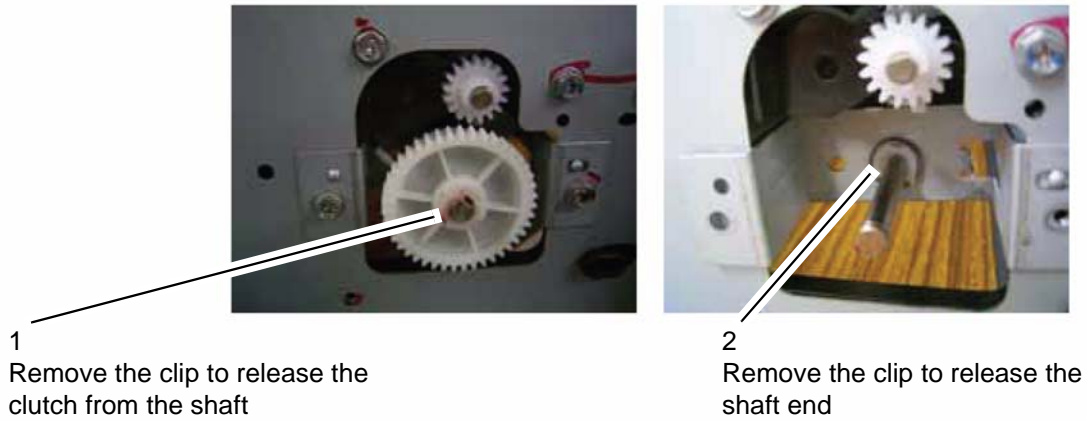

Figure 1

2. Remove the electromagnetic clutch assembly, Figure 2.



**Figure 2**

3. Release the second clip to remove the shaft, Figure 3.

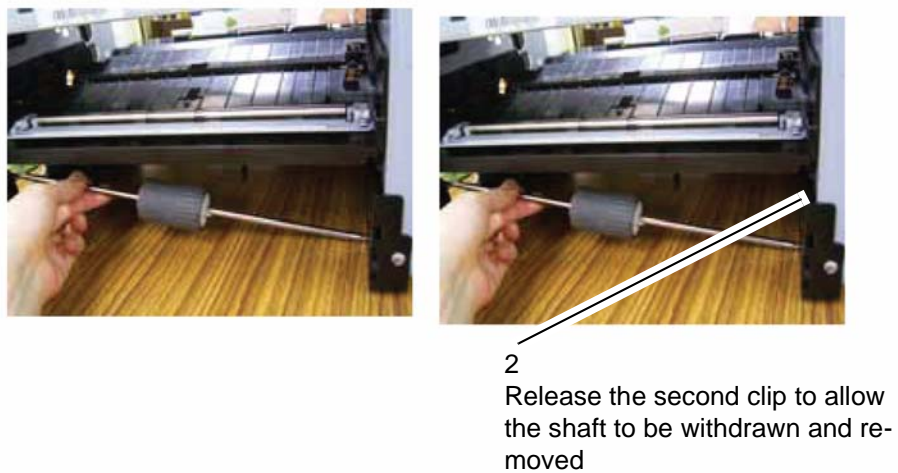

**Figure 3**

4. Remove the paper feed roller from the shaft, Figure 4.

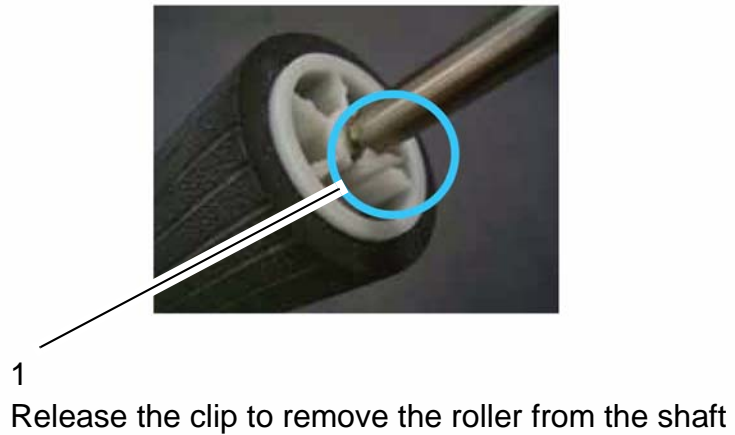

**Figure 4**

## Replacement

1. Replacement is the reverse of the removal procedure.

## REP 33 Registration Roller

Parts List on: [PL 11](#)

### **WARNING**

Switch off the electricity to the machine. Disconnect the power cord from the customer supply while performing tasks that do not need electricity. Electricity can cause death or injury. Moving parts can cause injury.

### **Preparation**

- Remove the paper tray.
- Remove the print cartridge.
- Remove the output tray assembly, [REP 14](#)

## Removal

1. Remove the surrounding components, Figure 1.

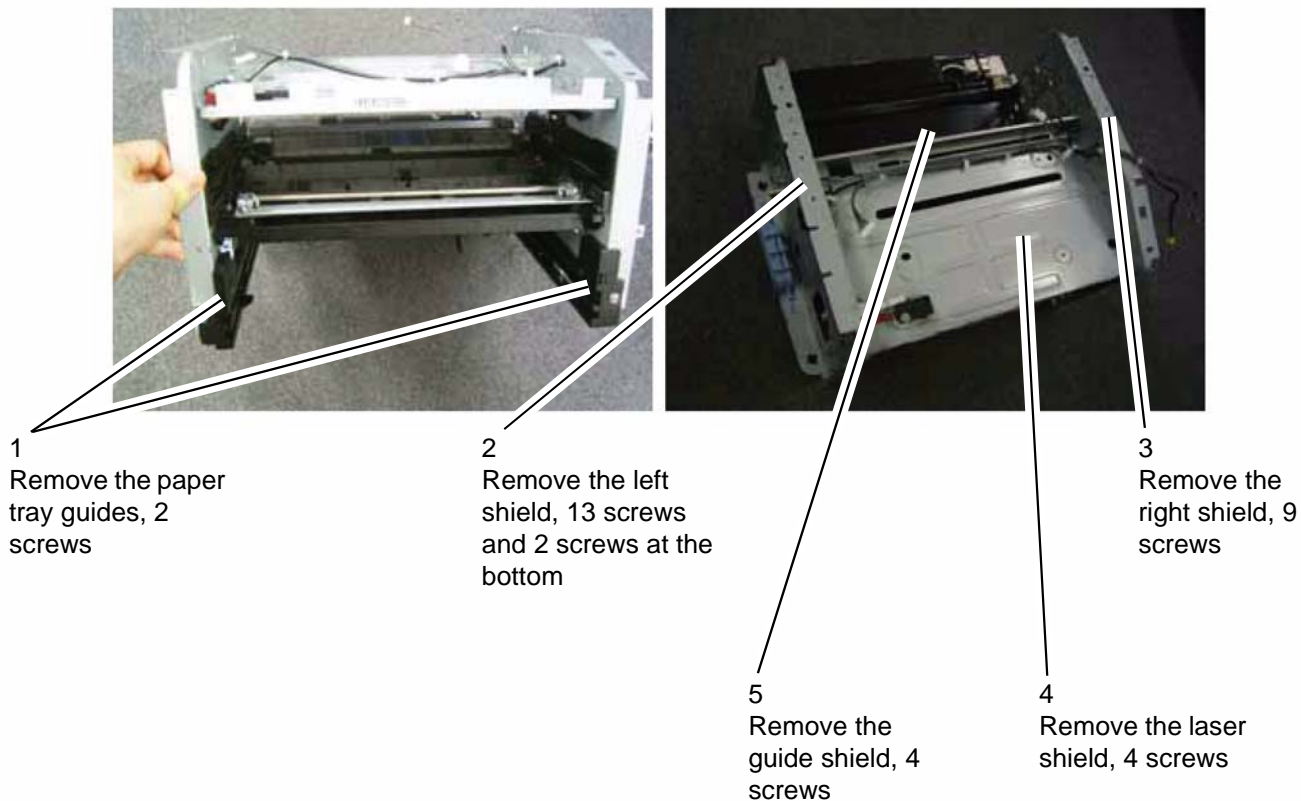

**Figure 1**

2. Remove the registration roller, Figure 2.



- 3  
Lift out the registration roller
- 2  
Remove 2 white bushings
- 1  
Remove 2 screws (circled)

**Figure 2**

## **Replacement**

1. Replacement is the reverse of the removal procedure.

## REP 34 Transfer Roller

Parts List on: [PL 11](#)

### WARNING

Switch off the electricity to the machine. Disconnect the power cord from the customer supply while performing tasks that do not need electricity. Electricity can cause death or injury. Moving parts can cause injury.

### Preparation

- Remove the print cartridge.
- Remove the output tray assembly, [REP 14](#).

### Removal

1. Remove the bushing at each end of the transfer roller, Figure 1.

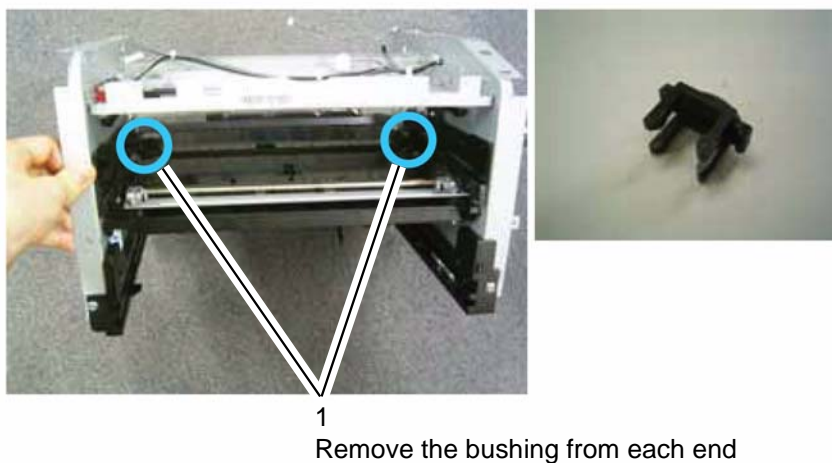

Figure 1



2. Use a screwdriver to lift the transfer roller out of the recess, Figure 2.



**Figure 2**

## **Replacement**

1. Replacement is the reverse of the removal procedure.

## REP 35 Fan Assembly

Parts List on: [PL 13](#)

### WARNING

Switch off the electricity to the machine. Disconnect the power cord from the customer supply while performing tasks that do not need electricity. Electricity can cause death or injury. Moving parts can cause injury.

### Preparation

- Remove the output tray assembly, [REP 14](#)

### Removal

1. Remove the fan assembly

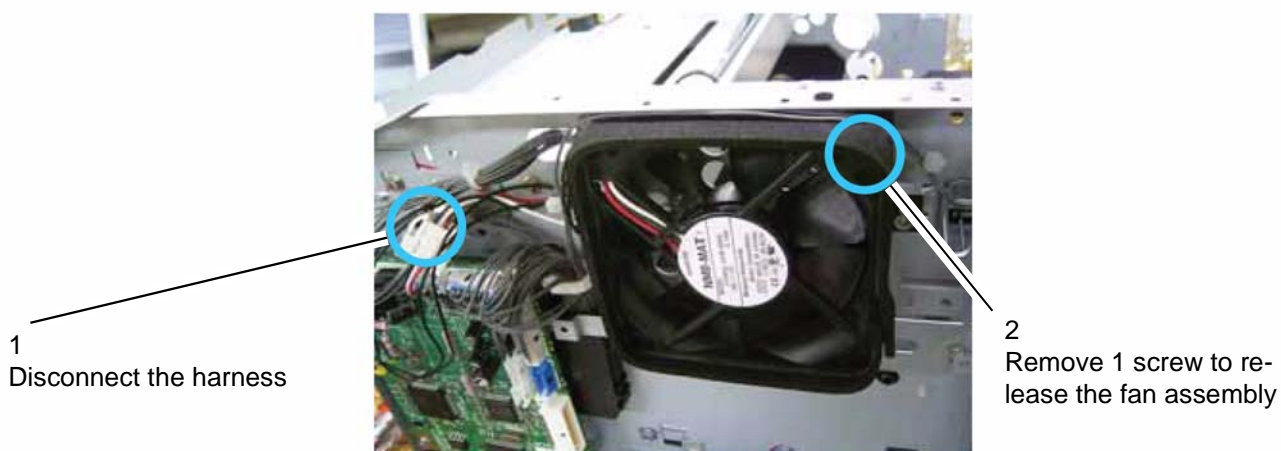

Figure 1

### Replacement

1. Replacement is the reverse of the removal procedure.

## REP 36 Main Motor

Parts List on: [PL 11](#)

### WARNING

Switch off the electricity to the machine. Disconnect the power cord from the customer supply while performing tasks that do not need electricity. Electricity can cause death or injury. Moving parts can cause injury.

### Preparation

- Remove the paper tray.
- Remove the print cartridge.
- Remove the output tray assembly, [REP 14](#).
- Remove the laser unit, [REP 24](#).

### Removal

1. Remove the surrounding components, Figure 1 (detail Figure 2).

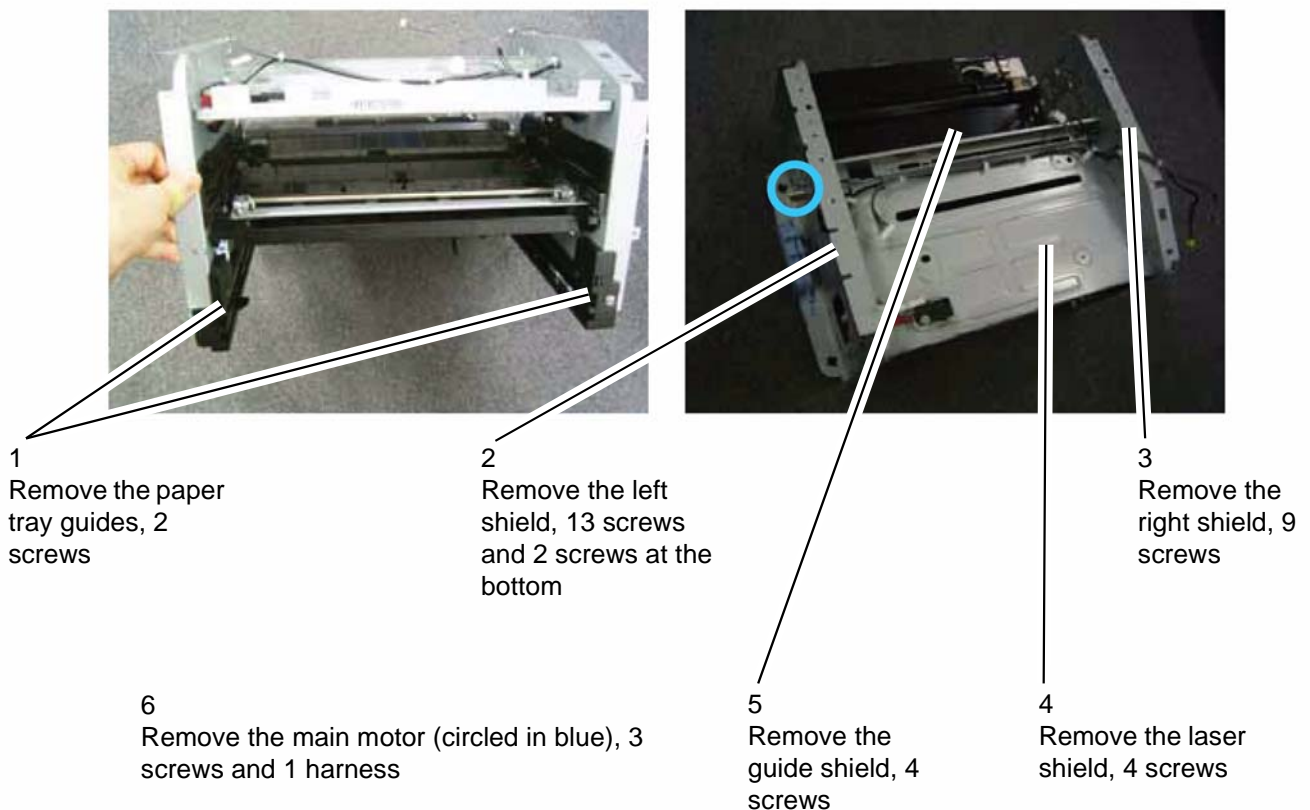

Figure 1



**Figure 2 Main motor**

## **Replacement**

1. Replacement is the reverse of the removal procedure.

## REP 37 Discharge Lamp Assembly

Parts List on: [PL 11](#)

### WARNING

Switch off the electricity to the machine. Disconnect the power cord from the customer supply while performing tasks that do not need electricity. Electricity can cause death or injury. Moving parts can cause injury.

### Preparation

- Remove the fusing unit, [REP 25](#).

### Removal

- Remove the discharge lamp assembly, Figure 1.

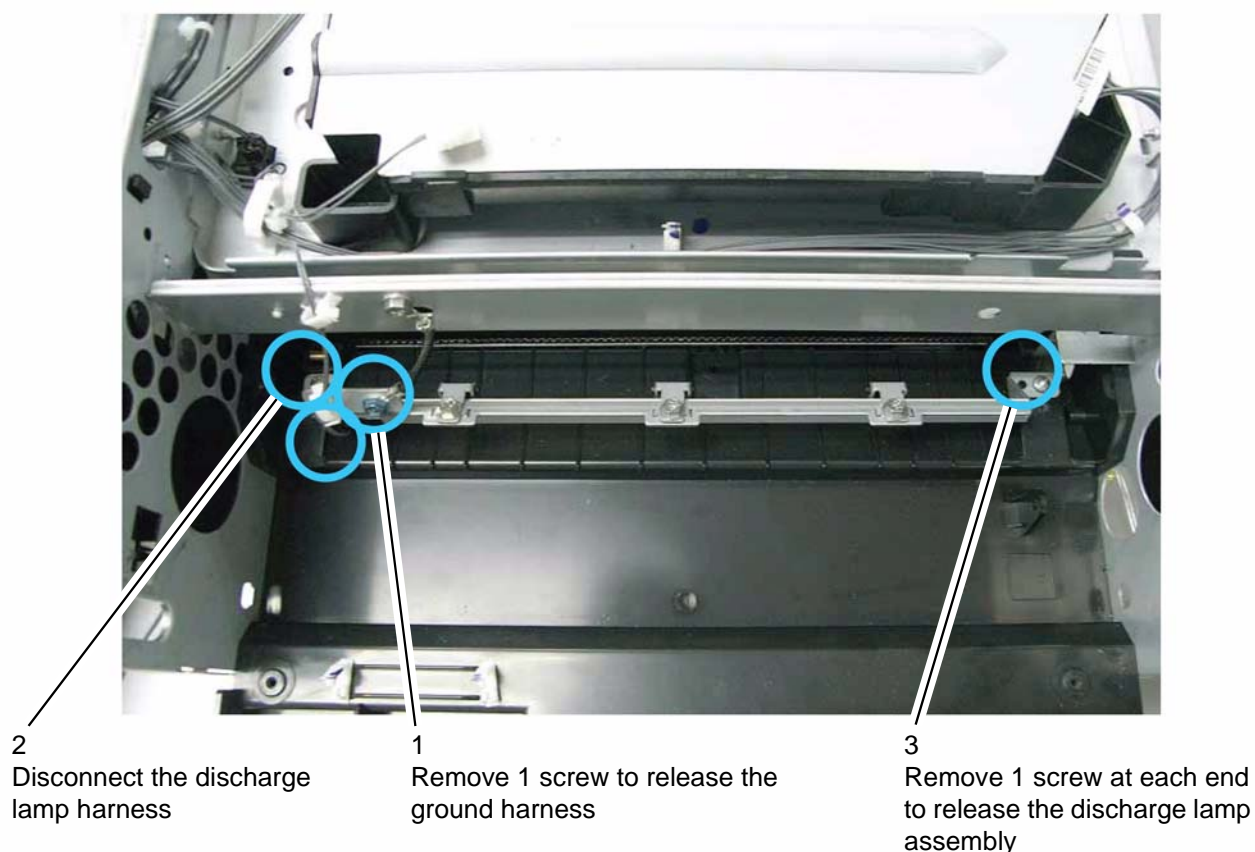

Figure 1

## Replacement

1. Replacement is the reverse of the removal procedure.

## REP 38 Scanner Cover and Document Pad

Parts List on: [PL 2](#)

### WARNING

Switch off the electricity to the machine. Disconnect the power cord from the customer supply while performing tasks that do not need electricity. Electricity can cause death or injury. Moving parts can cause injury.

### Preparation

None.

### Removal

#### Document Pad

1. Open the platen cover.
2. Remove the document pad located under the platen cover, Figure 1.



Figure 1

#### Platen Cover

3. Lift the platen cover to extract the two hinges from their slots and remove the platen cover.

### Replacement

1. Replacement is the reverse of the removal procedure.

This page is intentionally blank



---

## 5 Parts List

PL 1 Controls and Cables .....	<a href="#">5-2</a>
PL 2 Covers .....	<a href="#">5-4</a>
PL 3 Paper Exit and Rear Cover .....	<a href="#">5-6</a>
PL 4 Output Tray Assembly .....	<a href="#">5-8</a>
PL 5 Scanner .....	<a href="#">5-10</a>
PL 6 CIS Support .....	<a href="#">5-12</a>
PL 7 Automatic Document Feeder (3100MFP/X only) (1 of 3) .....	<a href="#">5-14</a>
PL 8 Automatic Document Feeder (3100MFP/X only) (2 of 3) .....	<a href="#">5-16</a>
PL 9 Automatic Document Feeder (3100MFP/X only) (3 of 3) .....	<a href="#">5-18</a>
PL 10 Paper Tray .....	<a href="#">5-20</a>
PL 11 Rollers and Drives .....	<a href="#">5-22</a>
PL 12 Fuser .....	<a href="#">5-24</a>
PL 13 Power Supply and Laser Unit .....	<a href="#">5-26</a>

# PL 1 Controls and Cables

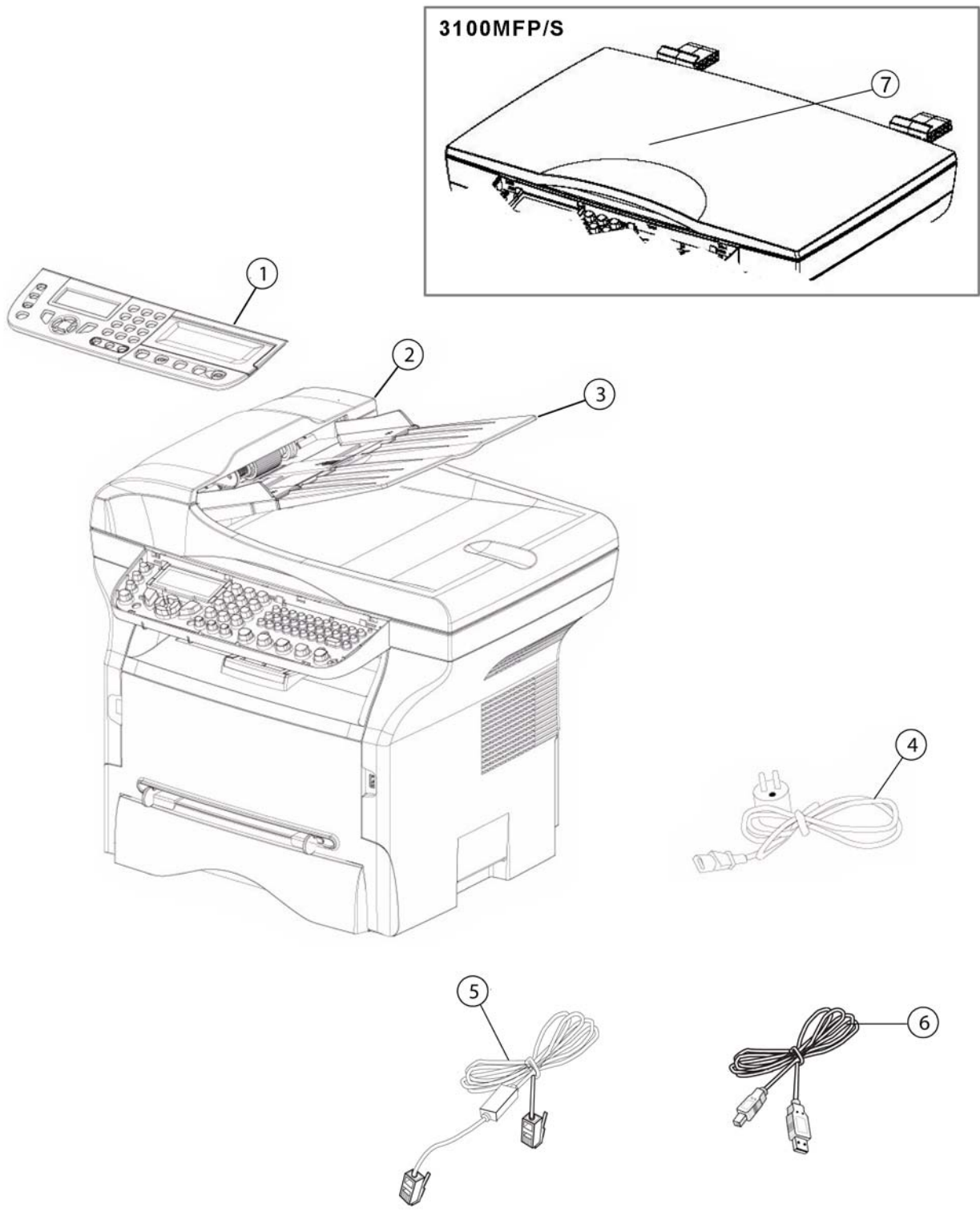

## PL 1 Controls and Cables

ITEM No.	REFERENCE	DESCRIPTION	QTY	R
1	002N02742	Pupitre PHASER Assemble Control panel assembly (3100 MFP/X)	1	<a href="#">REP 1</a>
1	002N02751	Pupitre PHASER Assemble Control panel assembly (3100MFP/S)	1	<a href="#">REP 1</a>
2	Refer to <a href="#">PL 2</a>	Flap équipé V2 ADF cover (3100MFP/X)	1	
3	Refer to <a href="#">PL 2</a>	ADF doc tray D7N coloré ADF doc tray D7N coloured	1	
4	117N01799	Cordon d'alimentation secteur AC Power cord (220V)	1	
4	177N01773	Cordon d'alimentation secteur AC Power cord (110V)	1	
5	117N01774	Cordon ligne téléphonique Phone line cord (3100MFP/X USSG/XCL)	1	
6	117N01800	Cordon USB types A+B L=1,50m + étiquette A+B types USB cable L=1,50m with label	1	
7	Refer to <a href="#">PL 2</a>	Platen cover (3100 MFP/S)	1	

# PL 2 Covers

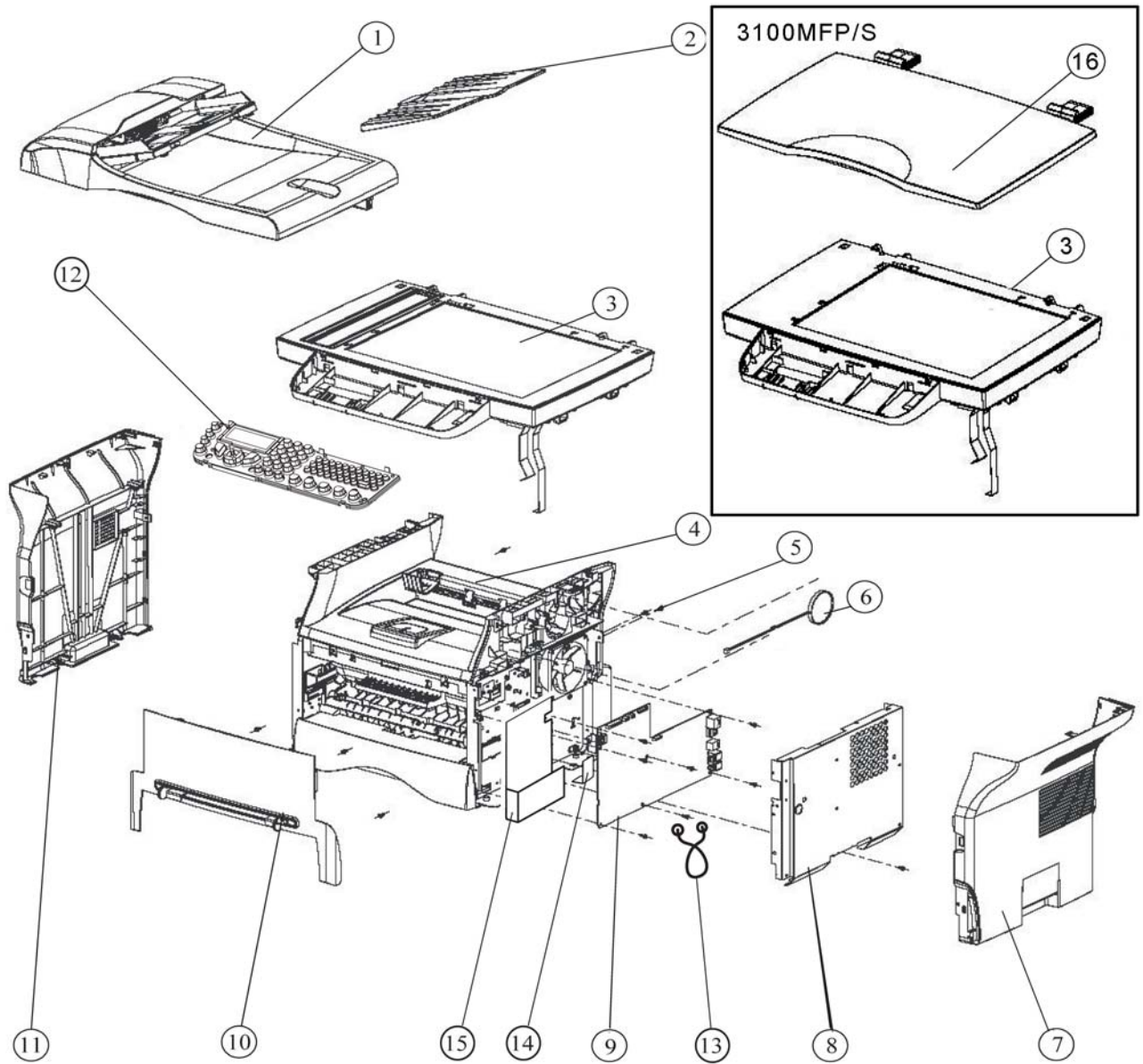

## PL 2 Covers

ITEM No.	REFERENCE	DESCRIPTION	QTY	R
1	022N02364	Flap équipé V2 ADF assembly (3100MFP/X)	1	<a href="#">REP 2</a>
2	050N00523	ADF doc tray D7N coloré (3100MFP/X only) ADF doc tray D7N coloured (3100MFP/X only)	1	
3	109N00690	Scanner à plat LFF3 assemblé V2 Scanner assembly V2 (3100MFP/X)	1	<a href="#">REP 16</a>
3	002N00691	Scanner à plat LFF1 assemblé V2 Scanner assembly V2 (3100MFP/S)		<a href="#">REP 16</a>
4	Not spared	Equipement Imprimante V2 Grey White Output tray assembly	1	
5	Not spared	Vis AUTAR.M3X6 steel swch16A Screw M3X6 steel	15	
6	Not spared	Haut-parleur Speaker	1	
7	002N02743	Capot droit imprimante LFF V2 Coloré Right cover	1	<a href="#">REP 3</a>
8	015N00619	Tôle de blindage carte UC Shield plate of UC Board	1	<a href="#">REP 11</a>
9	140N63328	Carte UC Main PCB board (3100MFP/S) (220V)	1	<a href="#">REP 11</a>
9	140N63327	Carte UC Main PCB board (3100MFP/S) (110V)	1	<a href="#">REP 11</a>
9	140N63326	Carte UC Main PCB board (3100MFP/X) (110V)	1	<a href="#">REP 11</a>
9	140N63325	Carte UC Main PCB board (3100MFP/X) (220V)	1	<a href="#">REP 11</a>
10	002N02748	Porte façade avant imprimante assemblé Front door assembly	1	<a href="#">REP 3</a>
11	002N02744	Capot gauche imprimante LFF V2 Coloré Left cover	1	<a href="#">REP 3</a>
12	002N02749	Support Pupitre ASS.LFF3/4V2 XEROX Control Panel (3100MFP/X)	1	<a href="#">REP 1</a>
12	002N02753	Support Pupitre ASS.LFF1V2 XEROX Control Panel (3100MFP/S)	1	<a href="#">REP 1</a>
13	120N00526	Serre câble Twist-lok nylon Serre câble Twist-lok nylon	1	
14	102N13562	Mylar condensateur (3100MFP/X only) Capacitor mylar (3100MFP/X only)	1	
15	063N00112	Mylar de sécurité Security mylar	1	
16	252N02752	Capot scanner a plat assemble grisclair Platen cover (3100MFP/S)	1	<a href="#">REP 38</a>

# PL 3 Paper Exit and Rear Cover

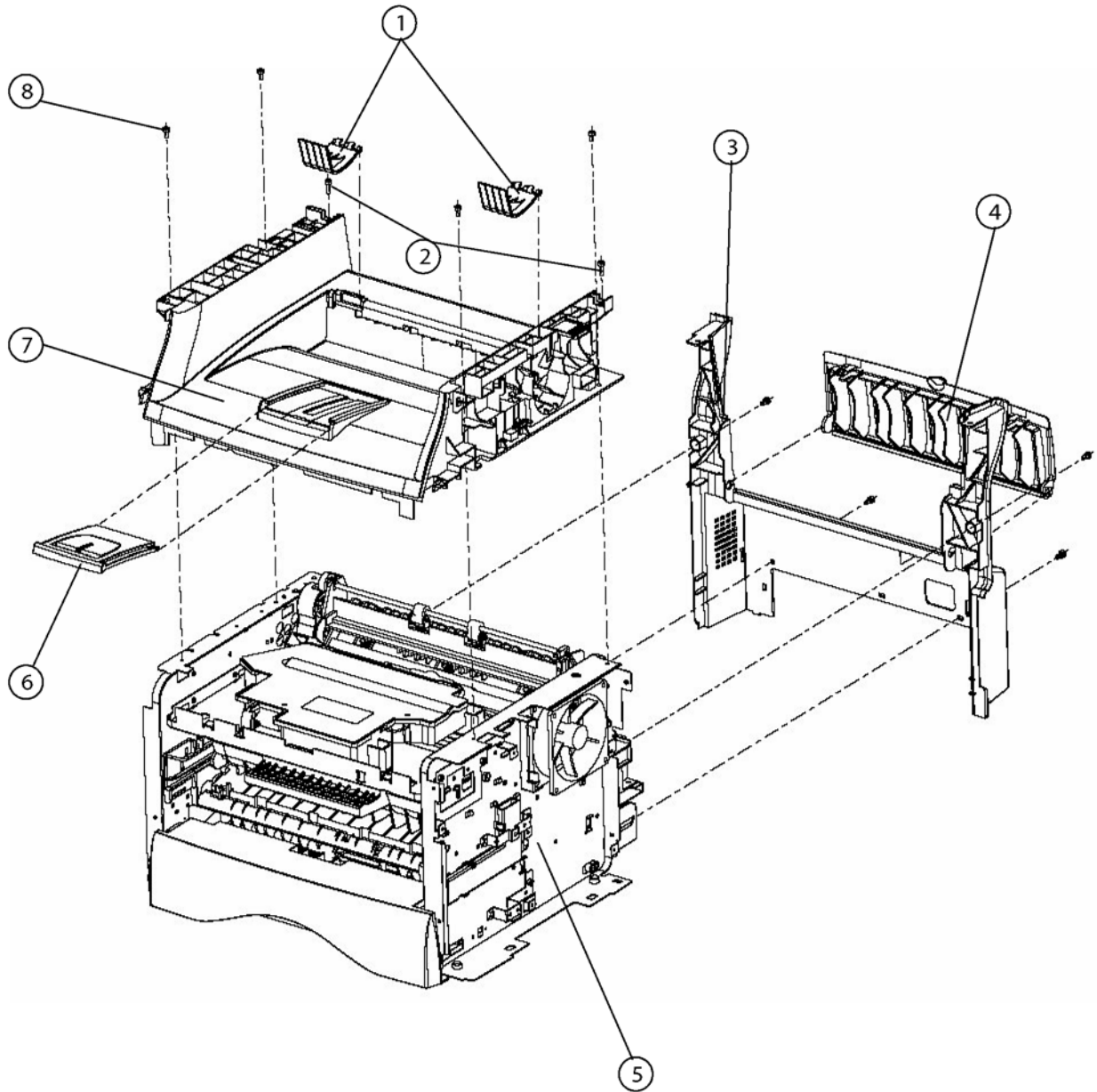

## PL 3 Paper Exit and Rear Cover

ITEM No.	REFERENCE	DESCRIPTION	QTY	R
1	038N00521	Guide papier sortie imprimante Exit paper guide	2	
2	Not spared	VIS 3x10 self tapping screw for plastic Screw 3x10 Self tapping screw for plastic	2	
3	002N02745	Capot arrière imprimante LFX V2 coloré Lower rear cover	1	<a href="#">REP 13</a>
4	002N02746	Trappe arrière Upper rear cover	1	<a href="#">REP 13</a>
5	Not spared	Imprimante Machine	1	
6	050N00522	Tirette imprimante + extension Tray exit+ extend	1	
7	050N00525	Interface équipée Gray White V2 (voir planche 4) Output tray assembly (refer to <a href="#">PL 4</a> )	1	<a href="#">REP 14</a>
8	Not spared	Vis autar. M3x6 steel swch16A Screw M3x6 steel	6	

## PL 4 Output Tray Assembly

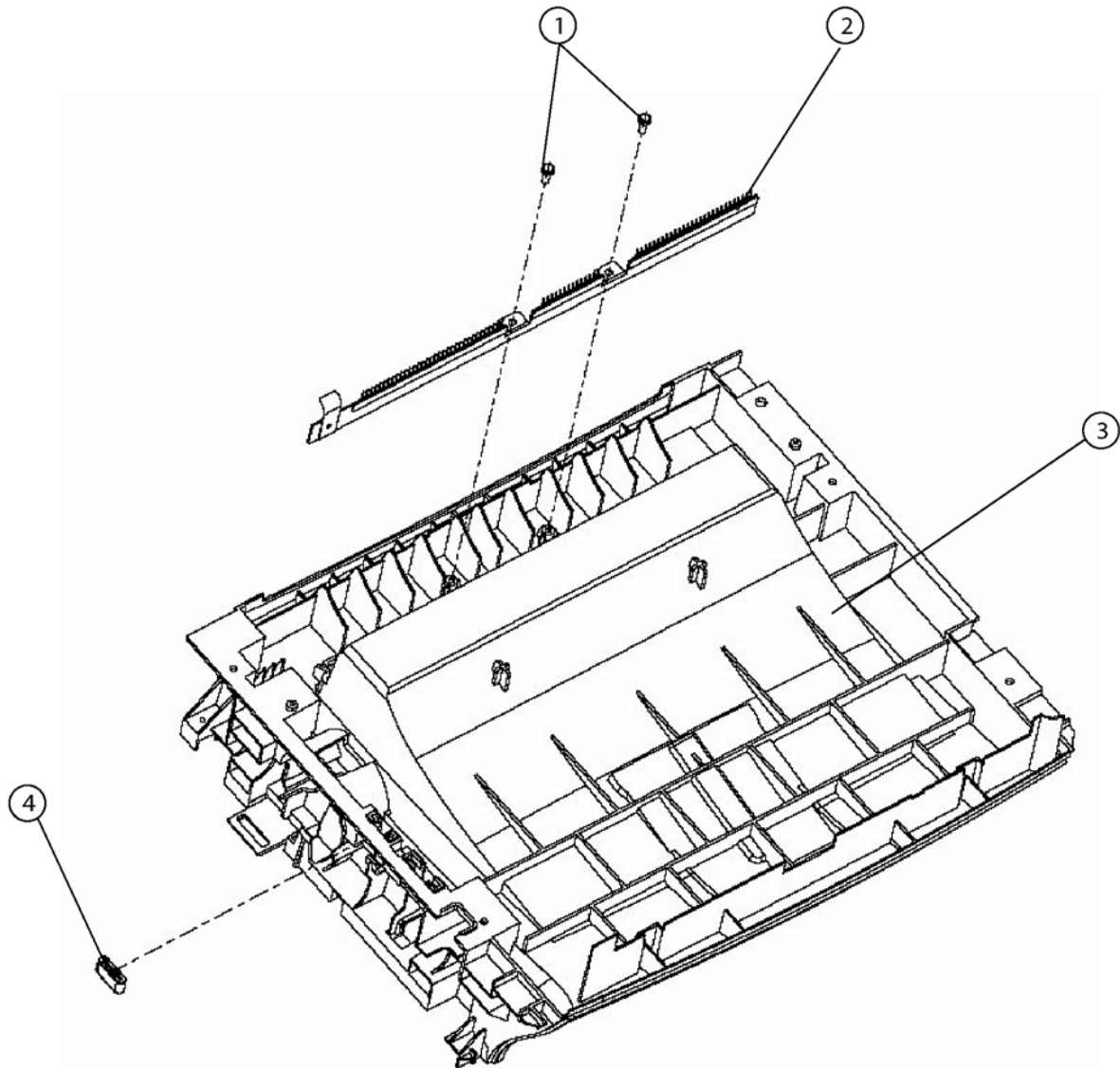



## PL 4 Output Tray Assembly

ITEM No.	REFERENCE	DESCRIPTION	QTY	R
1	Not spared	VIS 3x10 self tapping screw for plastic Screw 3x10 self tapping screw for plastic	2	
2	115N00872	Brosse antistatique Discharge brush	1	
3	050N00526	Interface LFX V2 Colorée Grey White Output tray	1	<a href="#">REP 14</a>
4	117N01797	Ferrite p.cable plat 3W800 10 cond. SP Ferrite p.cable plat 3W800 10 cond. SP		

# PL 5 Scanner

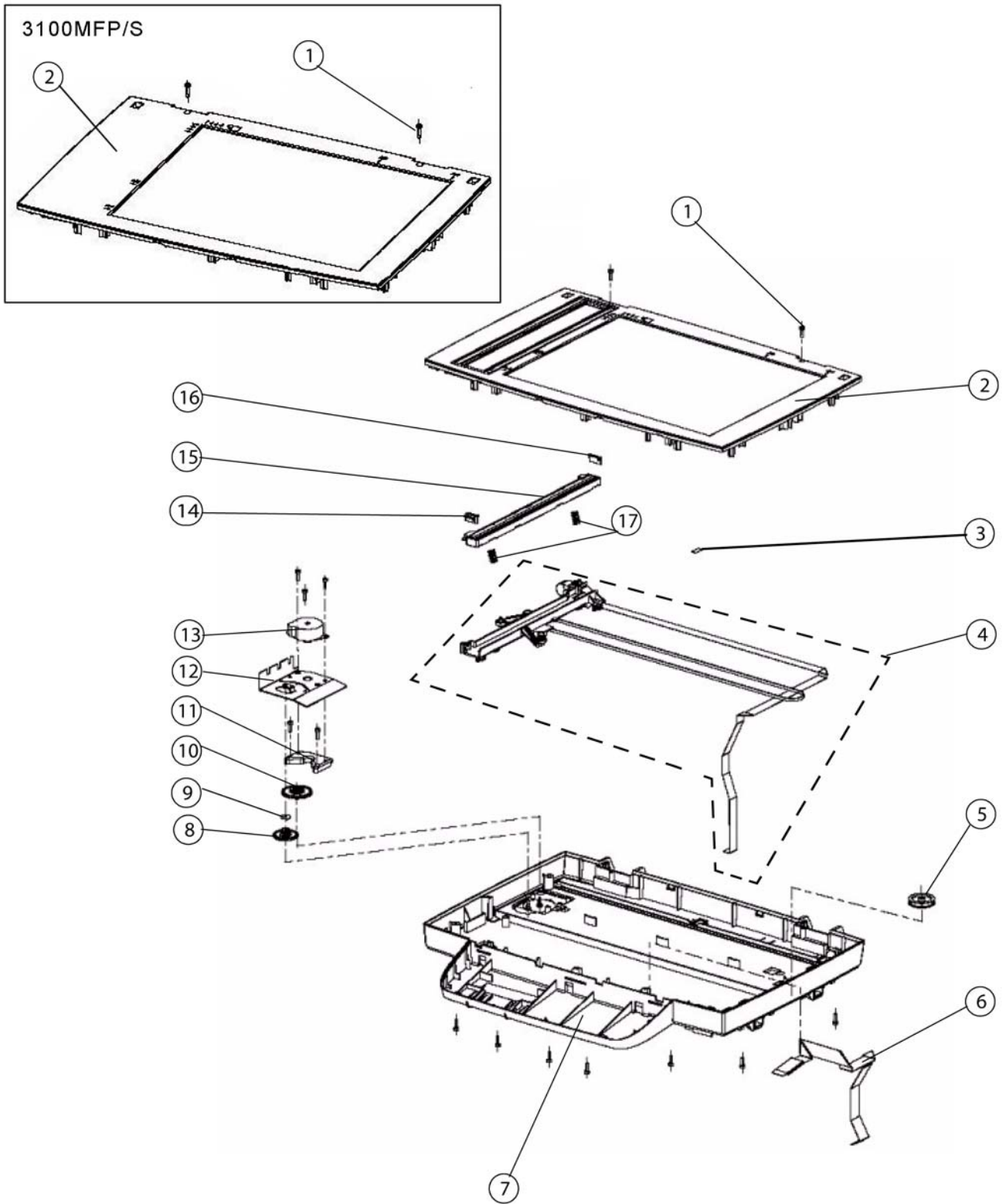

## PL 5 Scanner

ITEM No.	REFERENCE	DESCRIPTION	QTY	R
1	Not spared	Vis 3x10 self tapping screw for plastic Screw 3x10 Self tapping screw for plastic	14	
2	Not spared	Cadre vitre scanner LFF3 assemblé Scanner frame LFF3 assembly (3100 MFP/X)	1	<a href="#">REP 18</a>
2	Not spared	Cadre vitre scanner LFF1 assemblé Scanner frame LFF1 assembly (3100 MFP/S)	1	<a href="#">REP 18</a>
3	Not spared	Adhésif double face ferrite Ferrite D-tape	2	
4	Not spared	Support CIS LFX CIS support LFX	1	<a href="#">REP 21</a>
5	Not spared	Poulie renvoi courroie CIS colorée CIS drive pulley colored	1	
6	Not spared	Nappe console 16 points Ribbon cable	1	
7	Not spared	Fond scanner coloré V2 Scanner bottom colored V2	1	
8	Not spared	Pignon 55 dents scanner à plat coloré Scanner gear 55 teeth colored	1	
9	Not spared	Disque pignon 15-55 dents coloré CIS drive disc colored	1	
10	Not spared	Pignon 32/70 dents scanner à plat coloré Scanner gear 32/70 teeth colored	1	
11	Not spared	Interface support moteur colorée CIS drive adaptor colored	1	
12	Not spared	Tôle moteur scanner à plat CIS drive heat sink	1	
13	Not spared	Moteur scanner à plat LFF Scanner motor LFF	1	<a href="#">REP 22</a>
14	Not spared	Glissière CIS gauche colorée CIS slider left colored	1	
15	Not spared	CIS A4 600 DPI 1.5MS 3.3V SP CIS A4 600 DPI 1.5MS 3.3V LF	1	
16	Not spared	Glissière CIS droite colorée CIS slider right colored	1	
17	Not spared	Ressort CIS CIS spring	2	

# PL 6 CIS Support

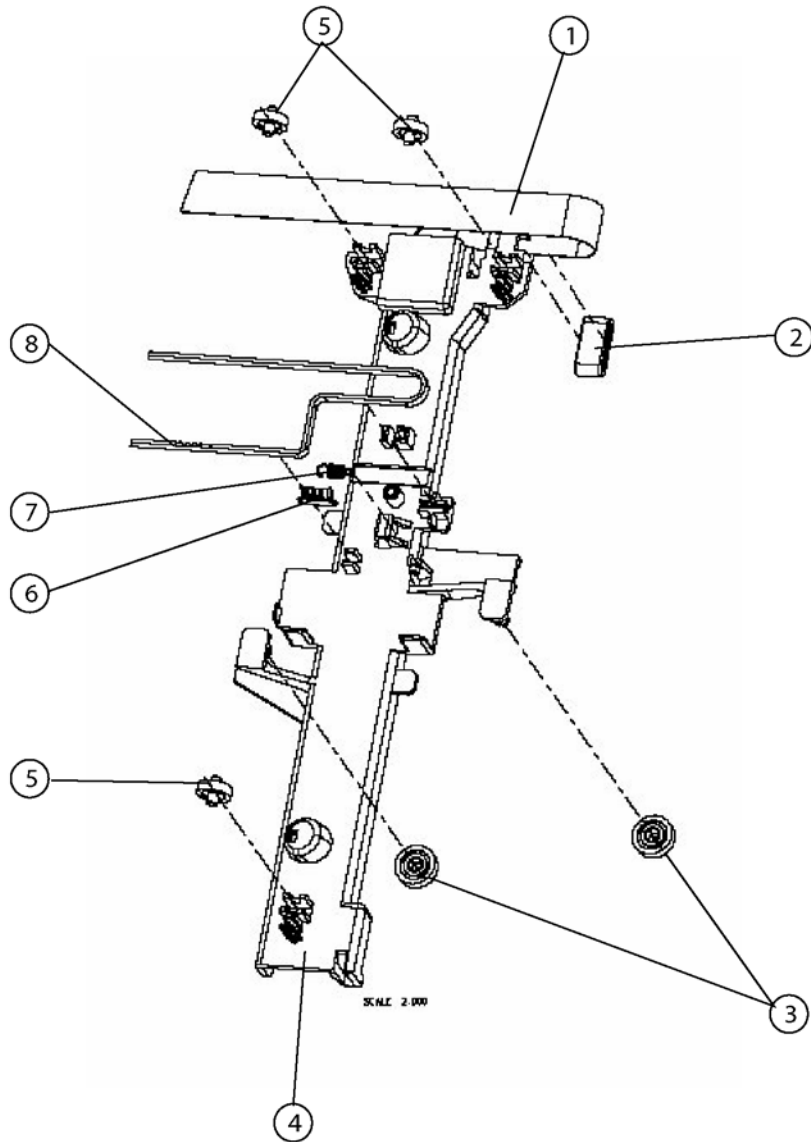

## PL 6 CIS Support

ITEM No.	REFERENCE	DESCRIPTION	QTY	R
1	117N01798	Nappe CIS 12 points 50 microns 12 pin 50 micrometers CIS flat cable	1	<a href="#">REP 20</a>
2	117N01797	Ferrite p.cable plat 3W800 10 cond. SP Ferrite p.cable plat 3W800 10 cond. SP	1	
3	Not spared	Guidage central chariot CIS coloré Central roller of CIS support colored	2	
4	Not spared	CIS support coloré CIS support colored	1	
5	Not spared	Guidage latéral chariot CIS coloré Lateral roller of CIS support colored	3	
6	Not spared	Connecteur courroie CIS CIS drive belt connection	1	
7	Not spared	Ressort courroie CIS belt spring	1	
8	Not spared	Courroie CIS drive belt	1	

# PL 7 Automatic Document Feeder (3100MFP/X only) (1 of 3)

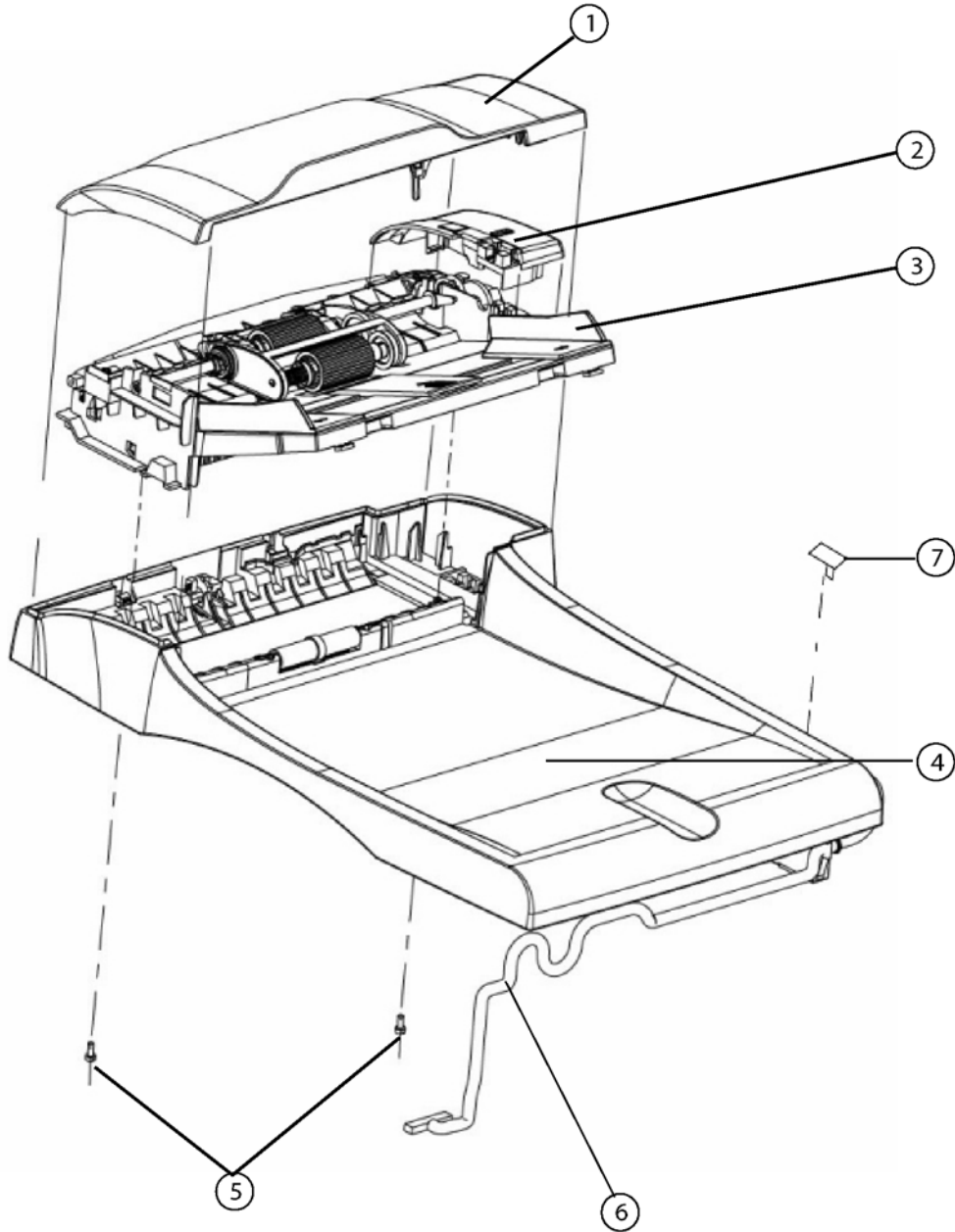

## PL 7 Automatic Document Feeder (3100MFP/X only) (1 of 3)

ITEM No.	REFERENCE	DESCRIPTION	QTY	R
1	002N02750	Capot ADF assemblé V2 ADF cover assembly V2	1	
2	002N02747	Capot moteur coloré Motor cover	1	
3	038N00522	Chemin papier interne deflect. ass V2 Document input tray	1	
4	050N00527	Flap assemblé V2 Document output tray	1	
5	Not spared	Vis autotartête large pour plast. 3x8 3x8 self tap. screw large for head plas	2	
6	Not spared	ADF motor&sensor wires overmolded LFX V2 ADF motor & sensor wires overmolded LFX V2	1	
7	Not spared	Cache charnière coloré Hide hinge colored	1	

# PL 8 Automatic Document Feeder (3100MFP/X only) (2 of 3)

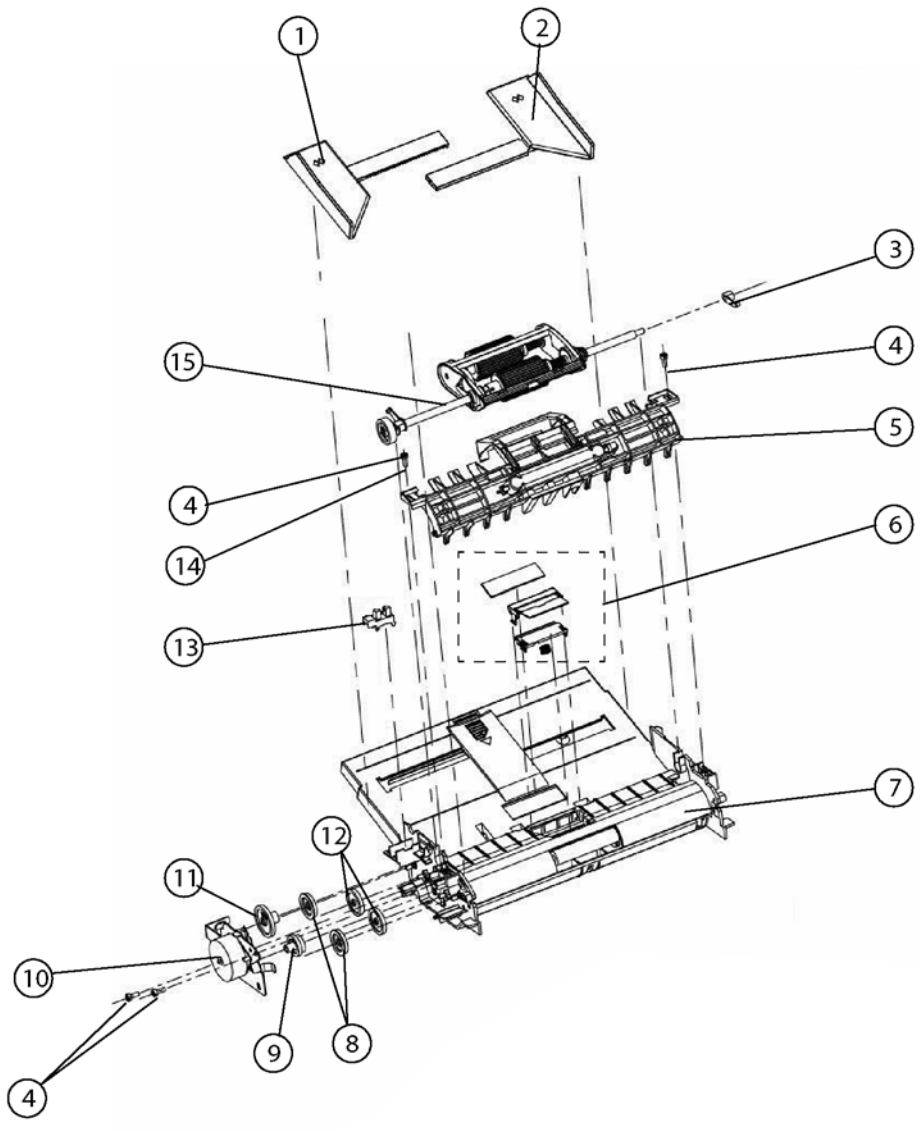



## PL 8 Automatic Document Feeder (3100MFP/X only) (2 of 3)

ITEM No.	REFERENCE	DESCRIPTION	QTY	R
1	Not spared	ADF slider left D7N coloré Left document guide	1	<a href="#">REP 10</a>
2	Not spared	ADF slider right D7N coloré Right document guide	1	<a href="#">REP 10</a>
3	Not spared	Palier quart de tour rouleau coloré Roller bearing	3	
4	Not spared	Vis autotartête large pour plast. 3X8 3X8 self tapping screw large for plastic	6	
5	Not spared	Guide papier supérieur assemblé Upper paper guide assembly	1	<a href="#">REP 7</a>
6	019N00958	Kit déliasseur pour LFX Retard pad assembly	1	<a href="#">REP 5</a>
7	Not spared	Introduceur papier deflect colorée Paper input guide	1	<a href="#">REP 6</a>
8	Not spared	Pignon 38 dents coloré 38 teeth analysis roller gear colored	2	
9	007N01602	Pignon 27-33 dents coloré 27-33 teeth gear colored	1	
10	001N00501	Support moteur assemblé Motor frame assembly	1	<a href="#">REP 22</a>
11	007N01603	Pignon 16-51 dents coloré 16-51 teeth gear colored	1	
12	007N01604	Pignon 42 dents coloré 42 teeth gear colored	2	
13	Not spared	Photo interrupter opic GP1A73A sp Sensor	1	
14	Not spared	Rondelles M3X0,6 Washer M3X0.6	2	
15	Not spared	Chargeur assemble Feeder assembly	1	<a href="#">REP 4</a>

## PL 9 Automatic Document Feeder (3100MFP/X only) (3 of 3)

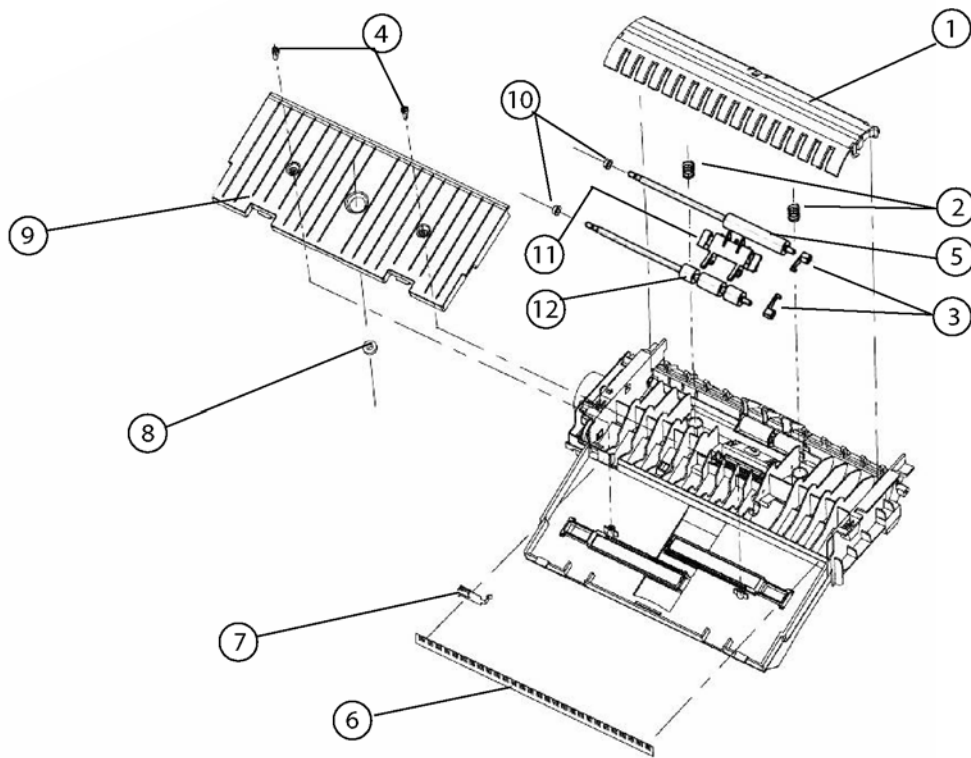

## PL 9 Automatic Document Feeder (3100MFP/X only) (3 of 3)

ITEM No.	REFERENCE	DESCRIPTION	QTY	R
1	Not spared	Chassis blanc coloré White frame plate colored	1	<a href="#">REP 9</a>
2	Not spared	Ressort palette blanche White frame plate spring	2	
3	Not spared	Palier quart de tour rouleau coloré Roller bearing turning colored	3	
4	Not spared	Vis autotartête large pour plast. 3X8 3X8 self tap.screw large for head plas	6	
5	022N02361	Rouleau analyse Registration roller	1	<a href="#">REP 9</a>
6	115N00873	Brosse antistatique auto adhésive 224 mm Antistatic brush	1	
7	Not spared	Reprise de masse balayette Brush ground plate	1	
8	Not spared	Pignon bac papier coloré Gear document tray colored	1	
9	Not spared	ADF wheelbox D7N coloré ADF wheelbox D7N colored	1	
10	Not spared	Palier LFX coloré LFX bearing colored	2	
11	Not spared	Deflecteur chemin papier colouree Paper deflector colored	1	<a href="#">REP 9</a>
12	Not spared	Rouleau analyse pour ejection Exit roller	1	<a href="#">REP 9</a>

# PL 10 Paper Tray

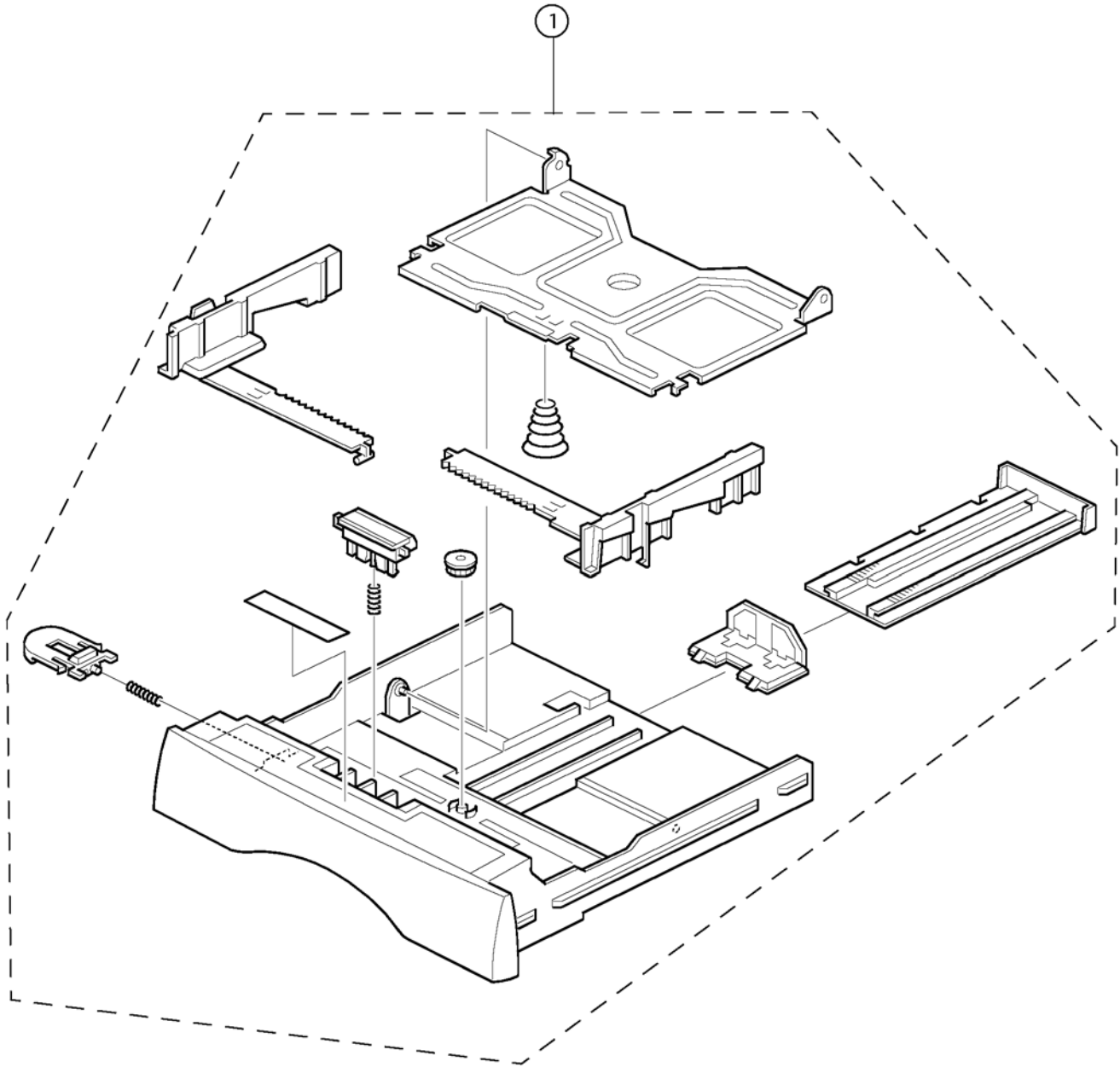

## PL 10 Paper Tray

ITEM No.	REFERENCE	DESCRIPTION	QTY	R
1	050N00524	Bac papier Paper tray unit	1	<a href="#">REP 23</a>

# PL 11 Rollers and Drives

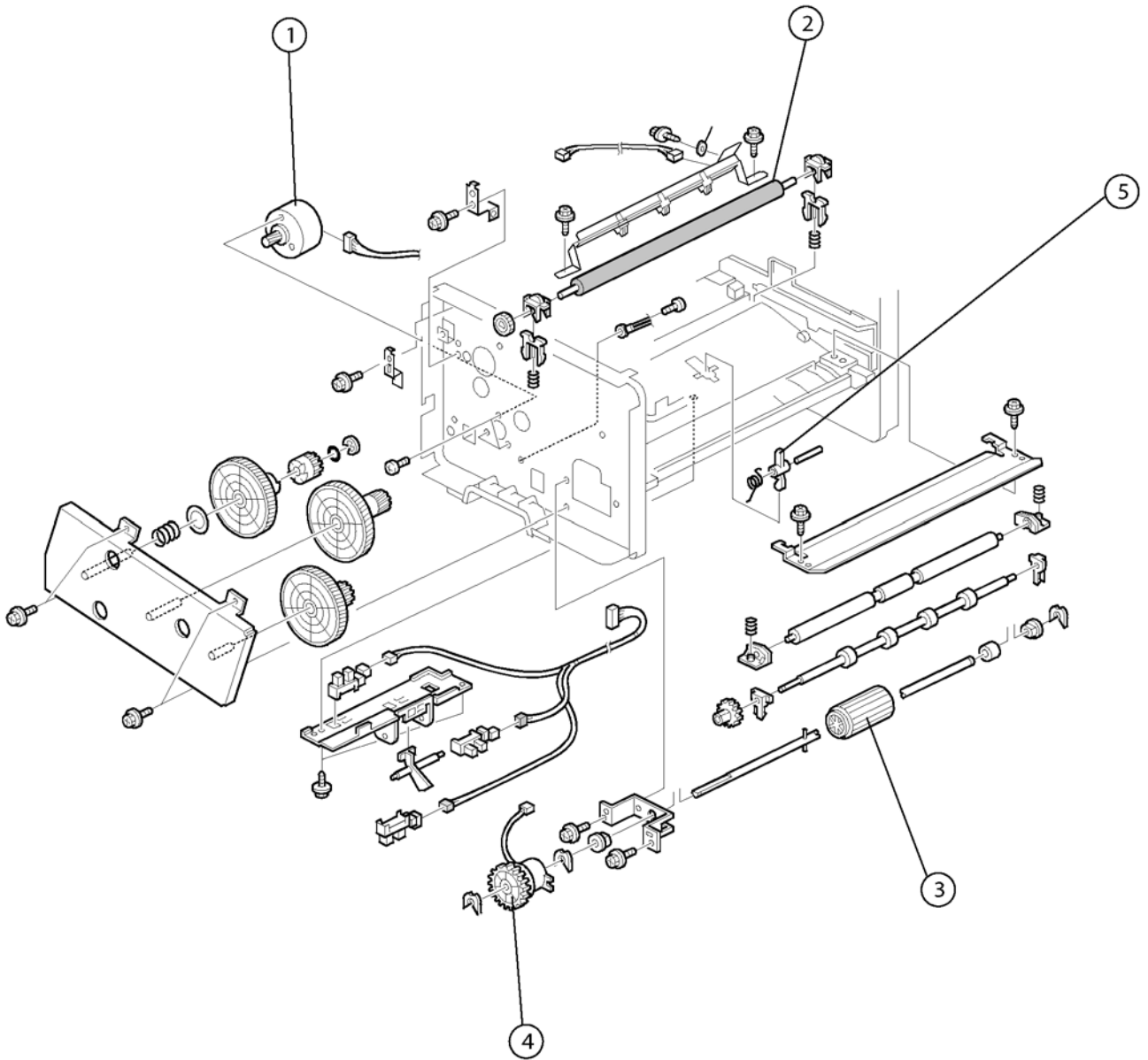

## PL 11 Rollers and Drives

ITEM No.	REFERENCE	DESCRIPTION	QTY	R
1	127N07574	Brushless motor - DC24V	1	<a href="#">REP 36</a>
2	022N02362	Transfer roller	1	<a href="#">REP 34</a>
3	022N02363	Paper feed roller - MM32	1	<a href="#">REP 32</a>
4	121N01171	Magnetic clutch -43z	1	
5	120N00525	Actuator - Paper pick-up sensor	1	

# PL 12 Fuser

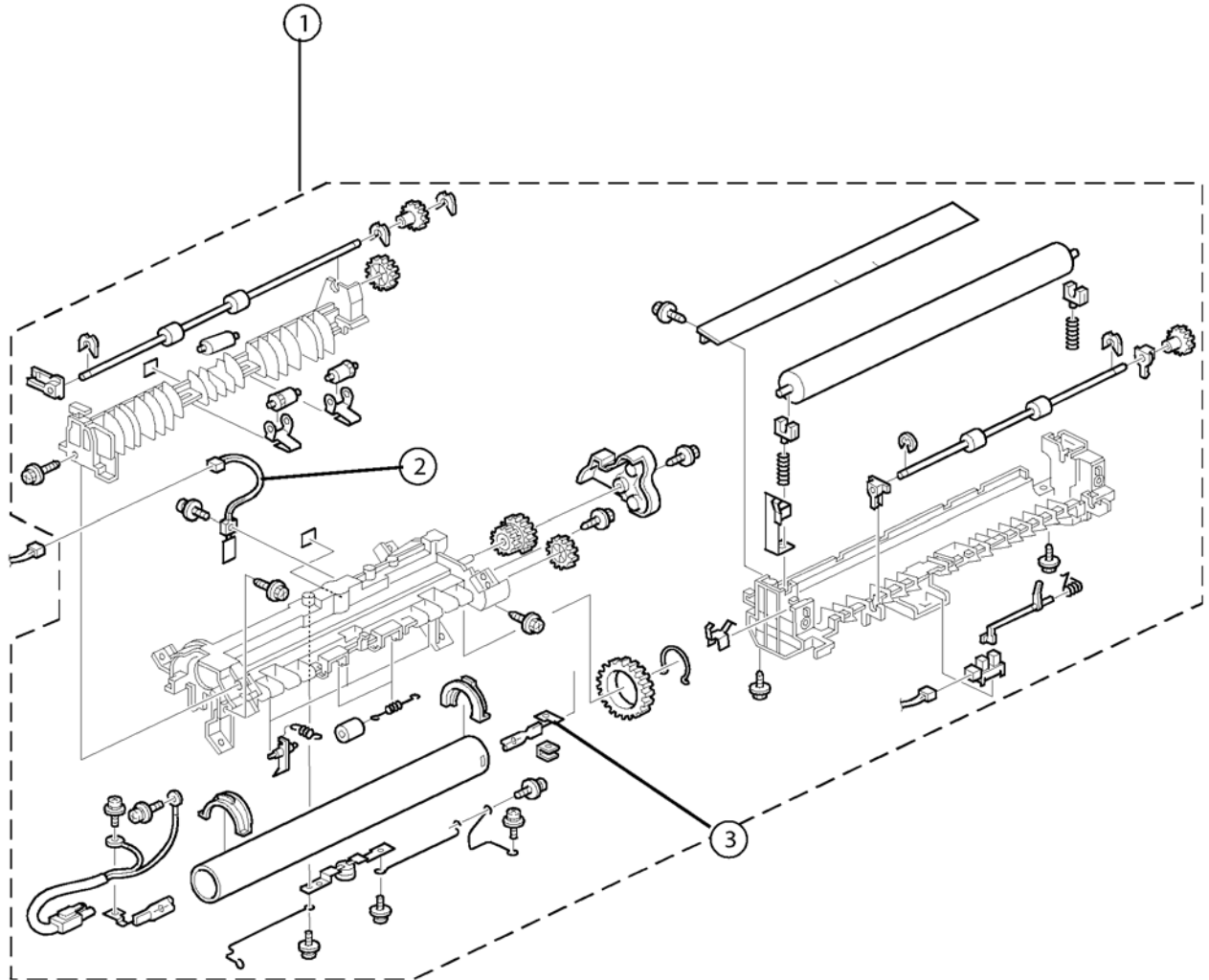



**PL 12 Fuser**

ITEM No.	REFERENCE	DESCRIPTION	QTY	R
1	126N00298	Unité de fusion Fuser (220V)	1	<a href="#">REP 25</a>
1	126N00297	Unité de fusion Fuser (110V)	1	<a href="#">REP 25</a>
2	130N01542	Fusing thermistor	1	<a href="#">REP 29</a>
3	126N00300	Heater (220V)	1	<a href="#">REP 27</a>
3	126N00299	Heater (110V)	1	<a href="#">REP 27</a>

# PL 13 Power Supply and Laser Unit

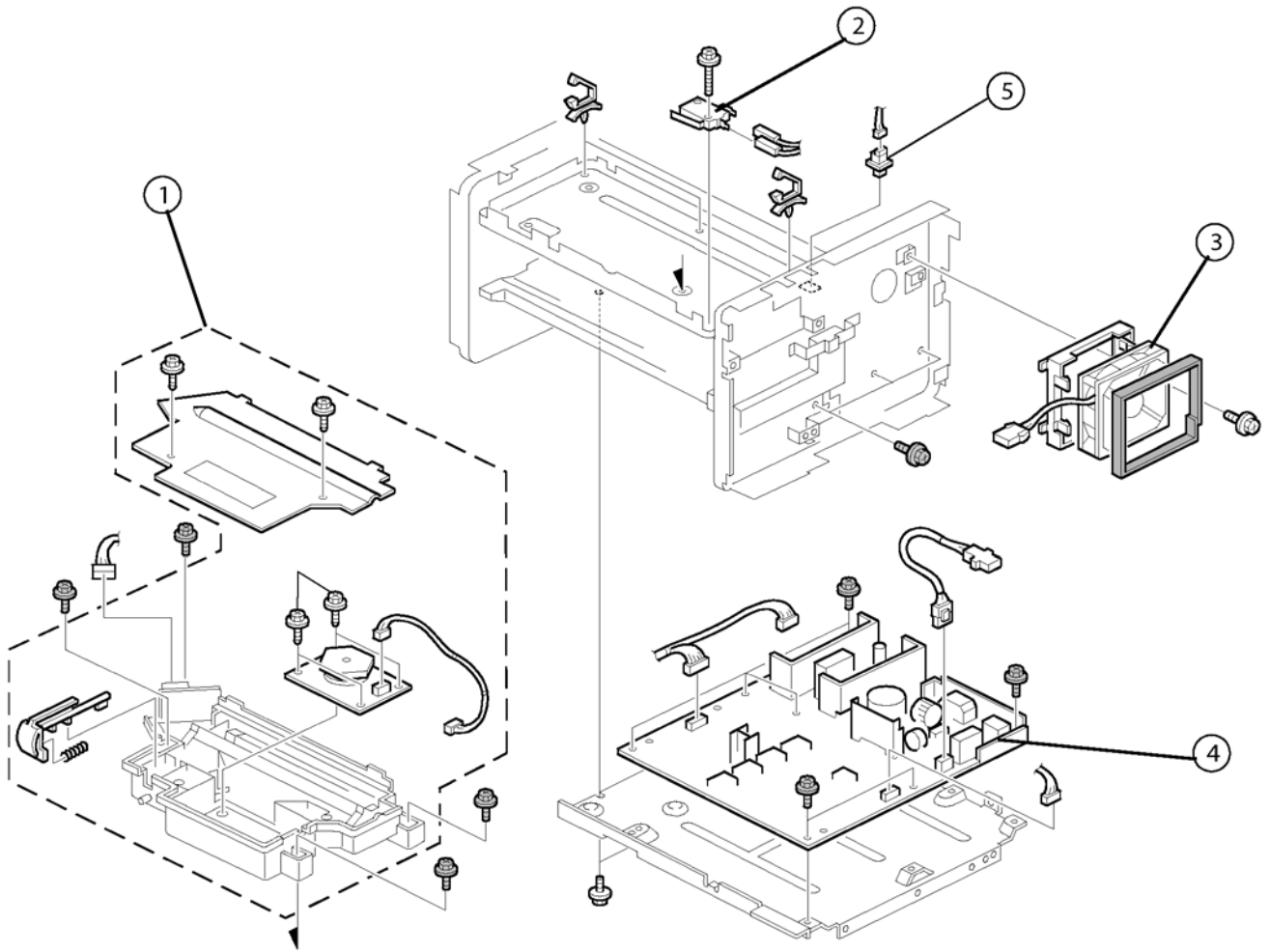

## PL 13 Power Supply and Laser Unit

ITEM No.	REFERENCE	DESCRIPTION	QTY	R
1	122N00280	Laser unit	1	<a href="#">REP 24</a>
2	110N01425	Micro switch	1	
3	127N07575	Fan assembly	1	<a href="#">REP 35</a>
4	105N02149	Power supply unit (220V)	1	<a href="#">REP 17</a>
	105N02148	Power supply unit (110)	1	<a href="#">REP 17</a>
5	110N01426	Push switch	1	

This page is intentionally blank

## 6 General Procedures and Information

GP 1 Presentation .....	<a href="#">6-3</a>
GP 2 Characteristics (Xerox 3100MFP/X and 3100MFP/S) .....	<a href="#">6-7</a>
GP 3 Electronic Architecture .....	<a href="#">6-12</a>
GP 4 Print Cartridge Characteristics .....	<a href="#">6-18</a>
GP 5 Operation .....	<a href="#">6-19</a>
GP 6 Printer Language .....	<a href="#">6-20</a>
GP 7 Paper types .....	<a href="#">6-21</a>
GP 8 Space Requirements .....	<a href="#">6-22</a>
GP 9 Environmental Conditions .....	<a href="#">6-24</a>
GP 10 Connections .....	<a href="#">6-25</a>
GP 11 Connecting the Power and Switching on the Machine .....	<a href="#">6-29</a>
GP 12 Getting Started and Software Configuration .....	<a href="#">6-30</a>
GP 13 Downloading the Software .....	<a href="#">6-43</a>
GP 14 Remote Readout .....	<a href="#">6-45</a>
GP 15 Storing User Parameters And Activity Counters On The Machine .....	<a href="#">6-51</a>
GP 16 Packing and Transporting the Machine .....	<a href="#">6-52</a>
GP 17 Administrator Functions .....	<a href="#">6-53</a>
GP 18 Component Layout .....	<a href="#">6-58</a>
GP 19 Service Log .....	<a href="#">6-78</a>

This page is intentionally blank

## GP 1 Presentation

### General Description

#### 3100MFP/X

The Xerox 3100MFP/X consists of a colour scanner with a 600 Dpi resolution and a Black and White printer with a 600 Dpi resolution. These two components are integrated into a single compact machine. Documents are processed by a scanner using CIS (Contact Image Sensor) technology, via the ADF (Automatic Document Feeder) or via the document glass for bulky documents.

The control panel consists of:

- An alphanumerical keyboard and function keys to control the machine;
- An LCD display with 2 lines and a line of icons that allows users to view the command or alert messages;
- A smart card reader that allows validating consumables.

When replacing the printer assembly, it is recommended that the old consumable (print cartridge) be transferred to the new printer assembly for further use.

When replacing the consumable, carry out the installation procedure for the new consumable (refer to the User Guide booklet).

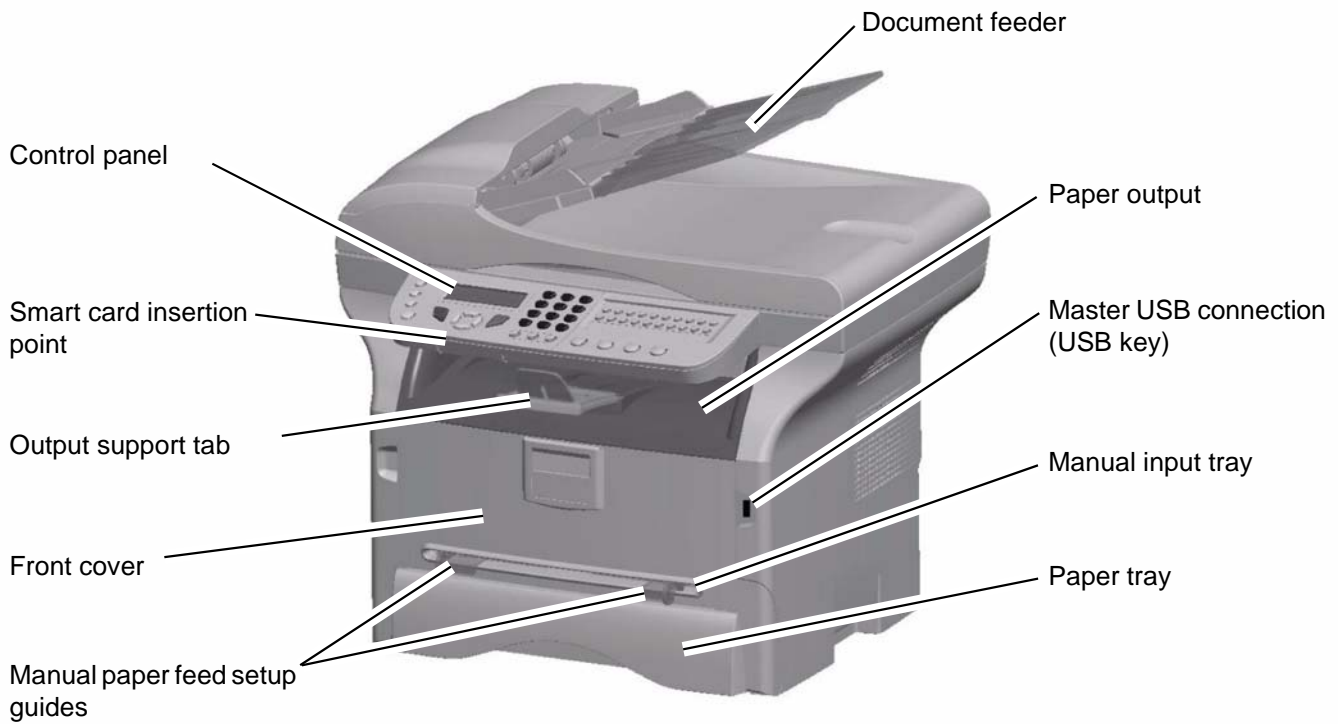

**Figure 1**

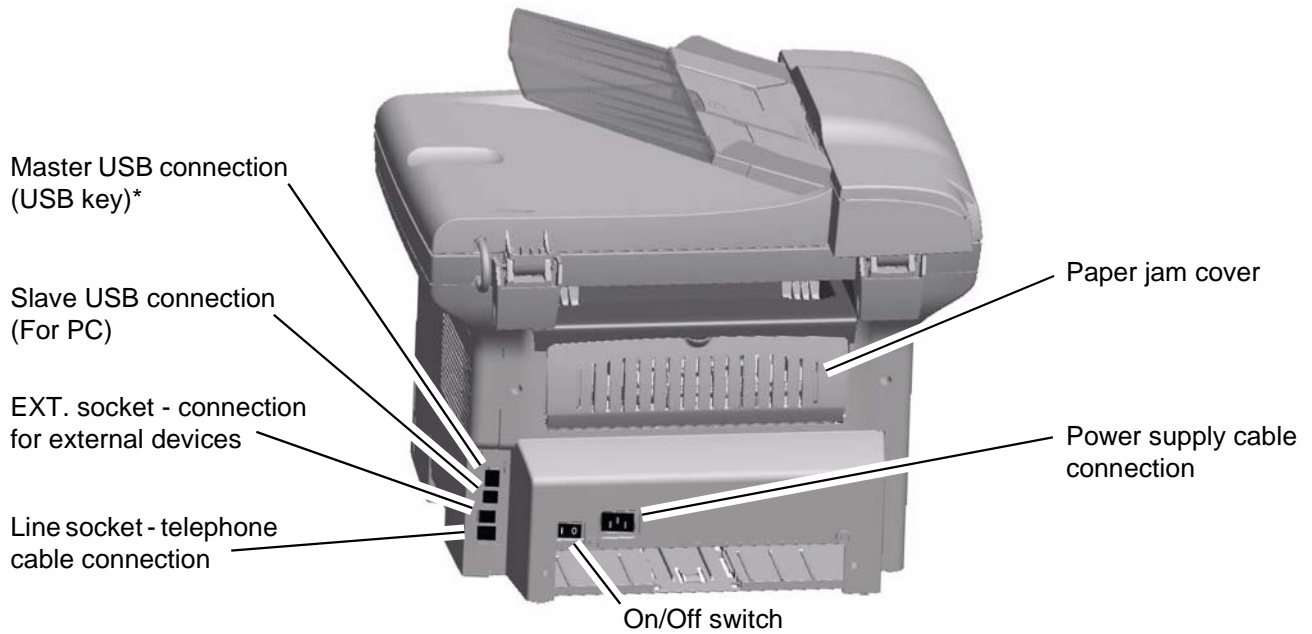

**Figure 2**

\*Can be used for the same function as the USB connection on the front side.



## General Description

### **X3100MFP/S**

The Xerox 3100MFP/S consists of a colour scanner with a 600 Dpi resolution and a Black and White printer with a 600 Dpi resolution. These two components are integrated into a single compact machine. Documents are processed by a scanner using CIS (Contact Image Sensor) technology, via the document glass.

The control panel consists of:

- An alphanumerical keyboard and function keys to control the machine.
- An LCD display with 2 lines and a line of icons that allows users to view the command or alert messages;
- A smart card reader that allows validating consumables.

When replacing the printer assembly, it is recommended that the old consumable (print cartridge) be transferred to the new printer assembly for further use.

When replacing the consumable, carry out the installation procedure for the new consumable (refer to the User Guide booklet).

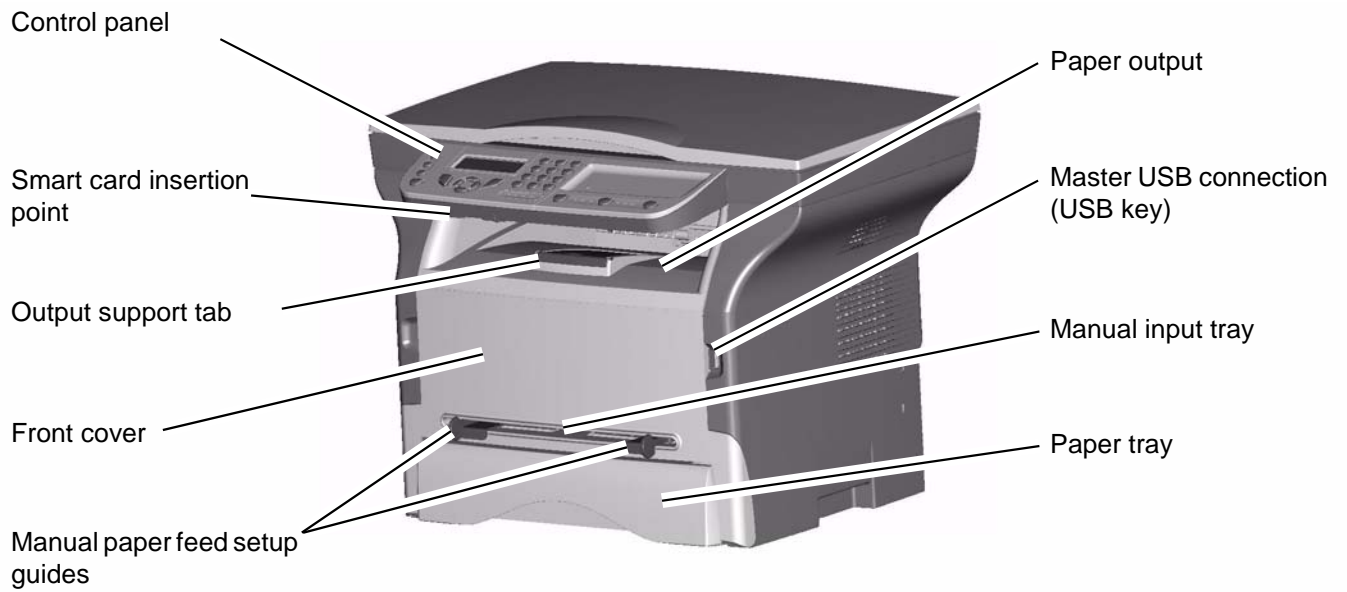

**Figure 3**

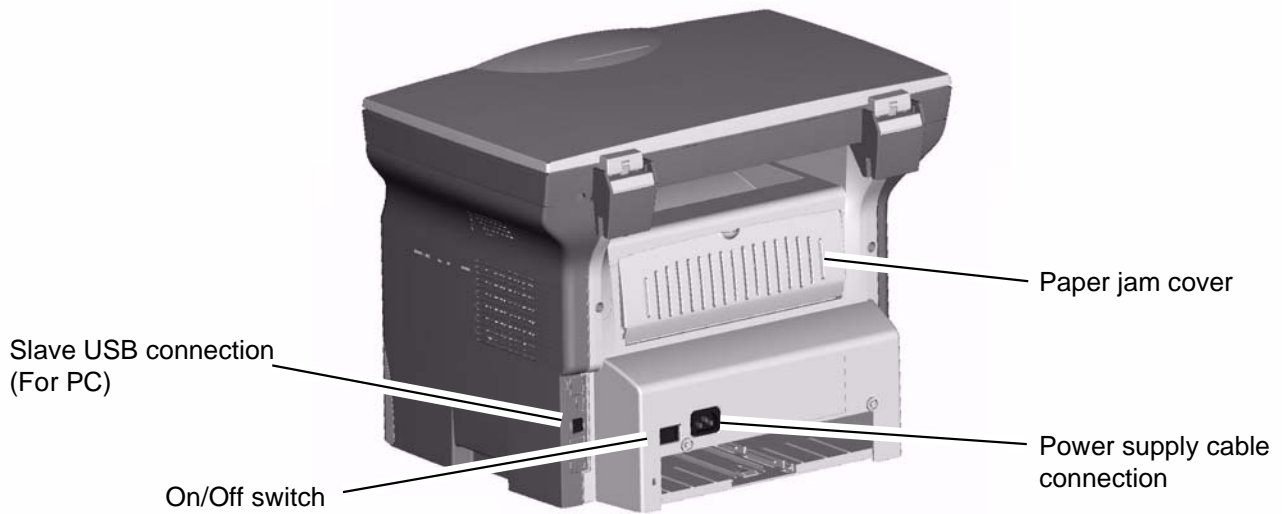

**Figure 4**

## **GP 2 Characteristics (Xerox 3100MFP/X and 3100MFP/S)**

### **Physical Characteristics**

#### **Environment**

##### **Operating:**

- The machine should not be exposed to direct sunlight.
- Power Supply
  - Single phase 120 V -50/60 Hz 8.5 A or Single phase 220-240 V - 50/60 Hz - 4.5 A according model (see rating plate).
- Power consumption in power save mode: 13 W.
- Typical consumption for printing: 450 W.
- Temperature: 10 °C to 27 °C [50 °F to 80.6 °F] with an ambient humidity included between 15 to 80% (up to 32°C [89.6 °F] with an ambient humidity included between 15 to 54%).
- Altitude: from 0 to 2500 meters (above sea level).
- Ambient light: 3000 lux.

##### **Storage of the machine and consumable (print cartridge):**

- Temperature: - 20 to 40 degrees C [-4 degrees F to 104 degrees F)
- Humidity: 20% to 80% (RH without condensation).

**Maximum storage time:**12 months.

## General Technical Characteristics

<b>General</b>	
Measurements L-D-H in mm	386 x 447 x 412 (15.1 x 17.6 x 16.2 inches) (3100 MFP/X)
Measurements L-D-H in mm	386 x 447 x 344 (15.1 x 17.6 x 13.5 inches) (3100 MFP/S)
Weight	13 kgs (28.6 lbs) (3100 MFP/X)
Weight	11.6 kgs (25.5 lbs) (3100 MFP/S)
<b>Consumables</b>	
Type (for platen and ADF scanners)	Inapa tecno SPEED A4 -80 g/m <sup>2</sup>
Type (for printer)	Xerox 75gsm
Document reference (DR)	
Type	ITU #1 -A4
Black/white ratio	3%
Resolution	Normal mode (200 x 100 DPI)
<b>ADF scanner (3100MFP/X only)</b>	
Type	CIS Colour and B/W
Colour analysis	Yes
Resolution in DPI	600
Grey scale	256
Colour scale	36 bits/pixel
Paper size	A4 (210 x 297 mm)
• Maximum width	216 mm (8.5 inches)
• Minimum width	145 mm (5.7 inches)
• Maximum length	1 m (39.3 inches)
• Minimum length	120 mm (4.7 inches)
Paper weight	60 to 90 g/m <sup>2</sup>
Capacity of document feeder	50 pages (80 g/m <sup>2</sup> )
Effective scanner width	210 mm (8.2 inches)
Zoom in steps of 1%	25% to 400%
Contrast	Yes (7 levels)
Brightness	Yes (7 levels)
Margin adjustment (left/right)	Yes
Origin adjustment	Yes

<b>Platen scanner</b>	
Type	CIS Colour and B/W
Colour analysis	Yes
Resolution in DPI	600 x 2400
Grey scale	256
Colour scale	36 bits/pixel
Window size	220 mm x 304 mm
Maximum paper width	Letter (215.9 x 279.4)
Zoom in steps of 1%	25% to 400%
Contrast	Yes (7 levels)
Brightness	Yes (7 levels)
<b>Printer</b>	
Type	Laser B/W
Printer language	GDI
Resolution in DPI	600 x 600
Maximum paper width (in mm)	Legal (215.9 x 355.6)
Paper feed tray	
• Page capacity (in pages)	250 (64g) / 200 (80g)
• Paper weight	60 to 105 g/m <sup>2</sup>
Manual paper feed	
• Capacity of pages (in pages)	1
• Paper weight	52 to 162 g/m <sup>2</sup>
• Transparent (laser printer compatible)	Yes
Page capacity of the output tray	50
Printing on envelopes	Yes (Manual paper feed)
Printer speed	20 PPM
First page printed after	13 s
Printing time at start-up	21 s
Printing area (in mm)	201.54 x 287
Consumable for RD document	
• Maximum initial print cartridge capacity (in ISOIEC19752 pages)	1.5K prints
• Management of consumables (depending on model)	By smart card
• Weight of print cartridge (in Kg)	1.2
• Toner saving function	Yes

<b>Copier</b>	
Type	Black/White
Input resolution (optical) in DPI	300 x 300 (fast) or 600 x 600 (quality)
Output resolution in DPI	600 x 600
Maximum paper size (in mm)	Legal (215.9 x 355.6)
Maximum speed for 300 x 300 (RP) resolution	20 PPM
Maximum speed for 300 x 300 resolution (Letter)	21 PPM
First page printed after	13 s
Multicopy	1 to 99
Zoom	25% to 400%
Zoom steps	1%
Collated copies	Yes
<b>Keyboard and screen</b>	
Keyboard (3100MFP/X)	62 keys
Keyboard (3100MFP/S)	25 keys
Screen (3100MFP/X)	2 lines of 16 characters + 7 icons
Screen (3100MFP/S)	2 lines of 16 characters + 4 icons
<b>Fax-Modem (3100MFP/X only)</b>	
Type	PSTN - Super G3
Maximum speed in bps (V34Fax)	33 600
V34Fax capacity in bps	33 600 to 2 400
• Incrementation in bps	2 400
V17 capacity in bps	14 400, 12 000, 9 600, 7 200
V29 capacity in bps	9 600, 7 200
V27ter capacity in bps	4 800, 2 400
<b>Fax communication (3100MFP/X only)</b>	
Type	PSTN, ITU T-30, G3
Maximum speed in bps (V34Fax)	33 600
Coding	MH, MR, MMR, JBIG
ECM	T30 ECM
Time to transmit RD	2.5 s
Type of transmission	Memory and direct (ADF)
Max. send delay	24 hours
PSTN redial	last 10 numbers

<b>SMS Communication (3100MFP/X only)</b>	
Transmission	Yes (V23)
Reception	No
Mailing	10 directly 249 from directory
<b>DECT Telephone Communication (option) (3100MFP/X only)</b>	
Wireless DECT Telephone	Yes (via USB dongle)
SMS	No
Network notification	No
Answering device	No
<b>Directory (3100MFP/X only)</b>	
Capacity	250
Type	Name / PSTN and SMS number
Transmission list	32
Transmission list capacity	249
Alphabetical typing	Yes
Associated key	Yes
Import/export directory on PC	XML, EAB and CSV formats
Save directory on PC	XML format
<b>Geographical settings</b>	
Countries (3100MFP/X only)	25
Network (3100MFP/X only)	TBR21, FCC68 depending on model
Languages	17

## Component Characteristics

### Control Panel PWB

The control panel PWB interfaces with the keyboard keys and the LCD display. The LCD has its own driver in COB (Chip On Board). The card also has an external connector to the smart card which is managed by the CPU.

## **GP 3 Electronic Architecture**

The CPU card is based on the Digicolor2 circuit, which ensures the processor functions. All executable code is stored in the flash Z466. This flash is divided into two zones, one is reserved for storing code and the other is reserved for storing documents. The code is loaded in SDRAM from this flash and the processor executes its instructions from the SDRAM. The SDRAM also serves as the operating memory for Digicolor2.

### **CPU Card**

The CPU card is based on the Digicolor2 circuit, which ensures the processor functions. All the executable code is stored in the flash Z466.

This flash is divided into two zones. One zone is reserved for storing code and the other is reserved for storing documents.

The code is loaded in SDRAM from this flash and the processor executes its instructions from the SDRAM. The SDRAM also serves as the operating memory for Digicolor2.



Electronic Architecture

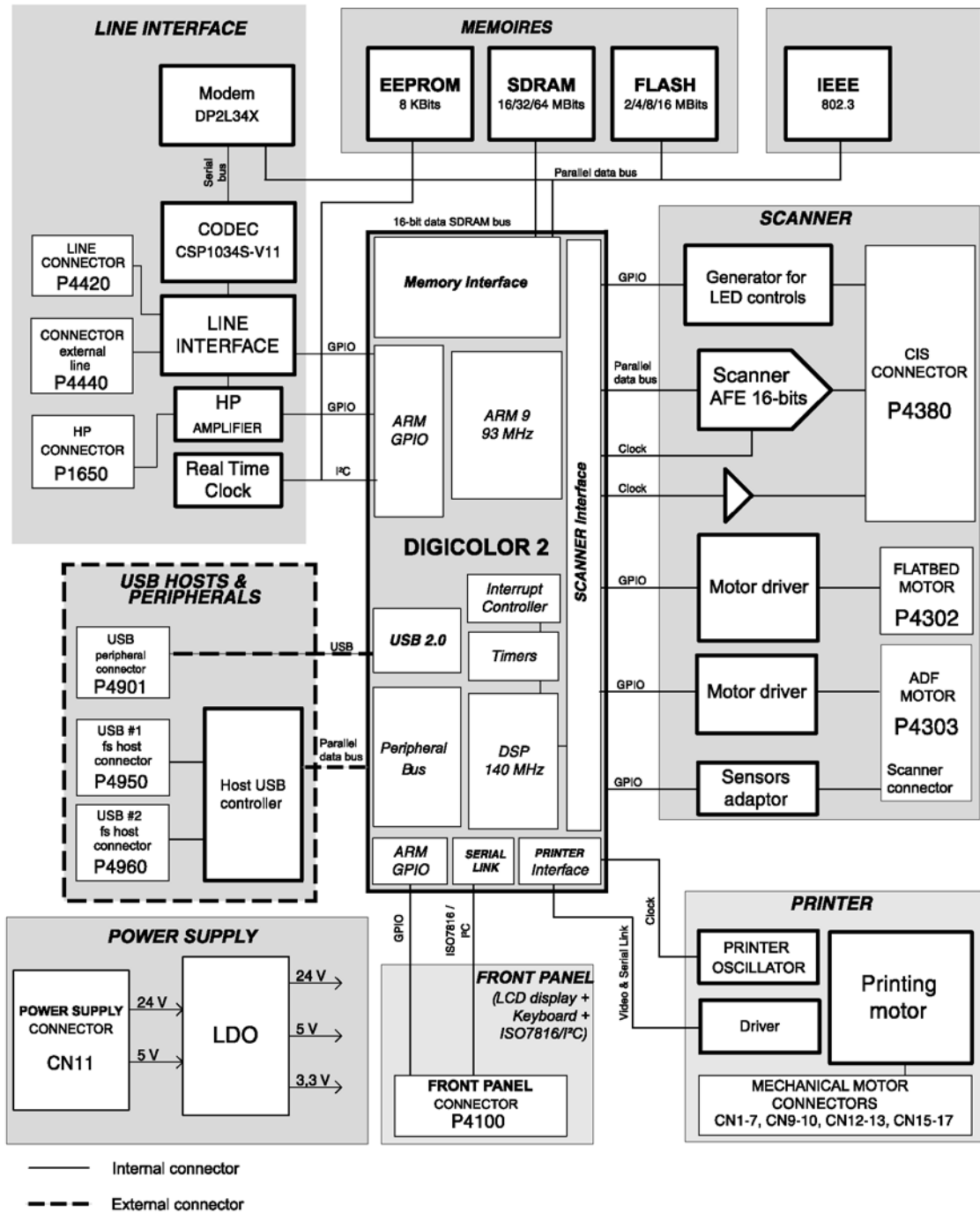

Figure 1 Overview of the CPU electronic architecture (3100MFP/X):

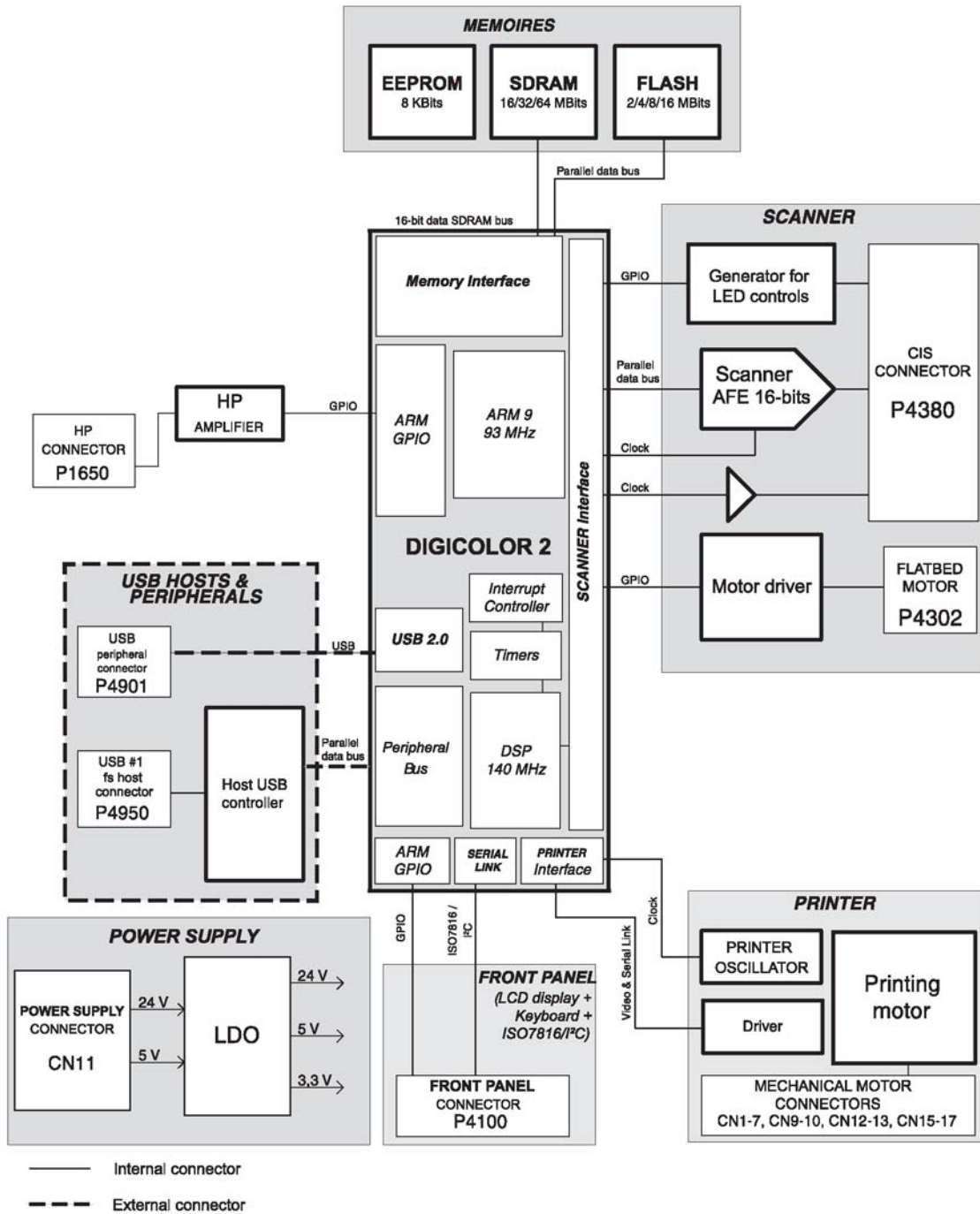

Figure 2 Overview of the CPU electronic architecture (3100MFP/S):

### Power Supply

The 24V and 5V power supply are provided by the printer.

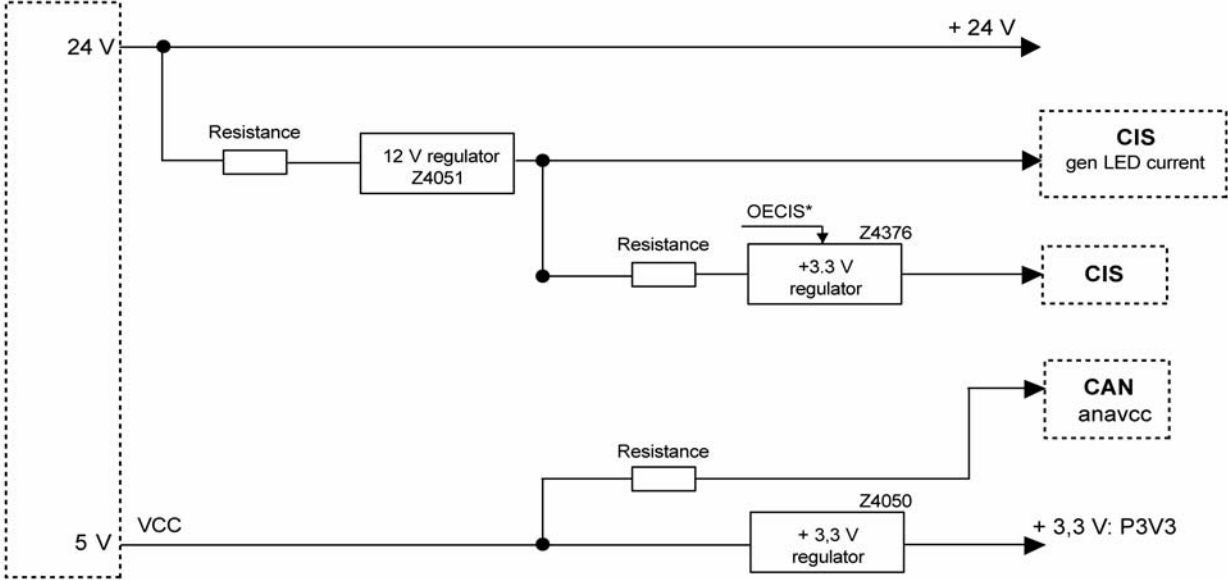

Figure 3 Diagram of printer power supply connections:

## CPU Card Clocks

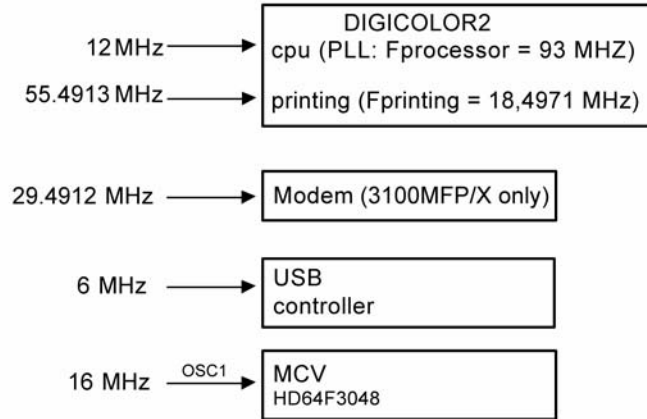
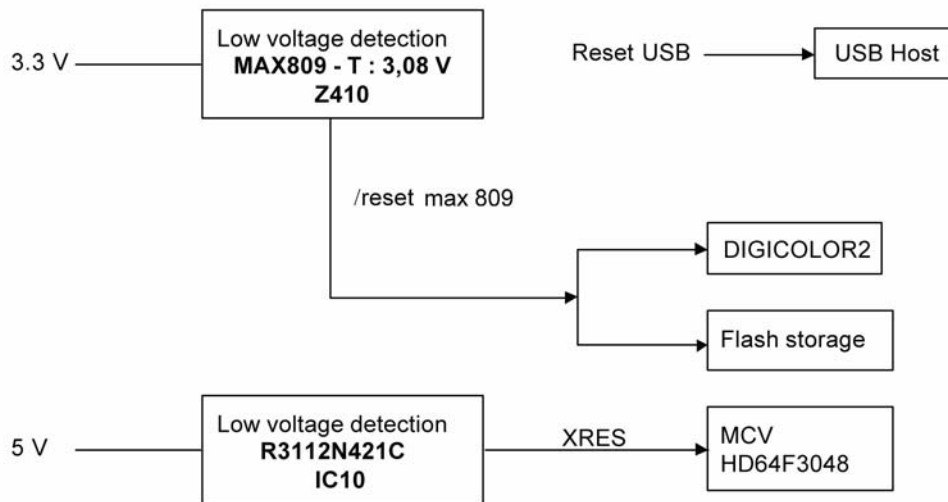

Figure 4

## Reset

The reset is generated from 3.3V as all logical parts (DIGICOLOR2, memory, ...) are supplied in 3.3V. The reset is active during at least 100ms.



**Figure 5 Printer's reset diagram:**

## **GP 4 Print Cartridge Characteristics**

For the print cartridge a counter assigns the percentage of toner that can still be used.

For a new cartridge this counter is initialized to the capacity announced by the vendor. This capacity is stored on the smart card provided with the new cartridge and requested for print cartridge replacement.

The percentage displayed (remaining quantity) is calculated in relation to the initial capacity of the cartridge (from 100% to 1%).

The values of the counter are regularly updated in the EEPROM memory. Each time the machine is switched on, the counter is read in the EEPROM memory.

## GP 5 Operation

The Xerox 3100MFP range is a Group 3 multi-function machine operating in accordance with the UIT-T T30 recommendations.

The 3100MFP/X consists of a laser printer, a CIS (Contact Image Sensor) colour ADF scanner, a colour flatbed scanner, a control panel with an alphanumeric keyboard and a LCD display with 2 lines of 16 characters (refer to the User Guide for a more complete description of the control panel).

It allows the following operations to be carried out:

- Fax transmission and reception on the switched telephone network using the V34 protocol (max. 33.6 kbits/s) and the V17 protocol (max. 14.4 kbits/s).
- SMS (Short Message Service) transmission on the switched telephone network using the V23 protocol (depending on the model).
- Photocopying documents.
- Local printing and scanning for PC via USB connections.

The 3100MFP/S consists of a laser printer, a colour flatbed scanner, a control panel with a numeric keypad and a LCD display with 2 lines of 16 characters (refer to the User Guide for a more complete description of the control panel).

It allows the following operations to be carried out:

- Photocopying documents.
- Local printing and scanning for PC via USB connections.

The electronics for both the 3100MFP/X and the 3100MFP/S are made up of a control panel PWB and a CPU board. The power supply is provided by the printer.

**Before performing any operations on the electronic CPU board, you should:**

1. Set the On/Off button to Off (position 0).
2. Unplug all external connectors (phone line connectors, USB connectors master, slave).
3. Unplug the power supply cord.

## **GP 6 Printer Language**

The machine uses the proprietary GDI printing language.

To install the drivers, carried out via the Companion Suite software installation, refer to the User Guide and the Companion Suite documentation kit.

**Remark(s):** The two-way PjL mode is supported.



## GP 7 Paper types

The following is a list of compatible paper formats:

Supports		Paper trays		
Media sizes	Dimensions (mm)	Main	Manual	Feeder
Legal	215.9 x 355.6	yes	yes	yes
A4	210 x 297	yes	yes	yes
Letter	215.9 x 279.4	yes	yes	yes
A5	148 x 210	yes	yes	yes
B5 (JIS)	182 x 257	no	yes	no
Executive	184.2 x 266.7	no	yes	no
A6	176 x 250	no	yes	no
<b>Capacities</b>		<b>250</b>	<b>1</b>	<b>50</b>

Figure 1

## GP 8 Space Requirements

The following diagram provides the machine's measurements, excluding optional accessories.

### 3100MFP/X



**Figure 1**

**3100MFP/S**



**Figure 2**

## GP 9 Environmental Conditions

When selecting the machine's location, the following factors should be taken into consideration:

- The room should be adequately ventilated.
- A standard single-phase power socket with earth (rated in conformance with the information on the label at the back of the machine) should be located no more than **2 meters (78 inches)** from the machine. This socket should be easily accessible.
- For easy access to the machine and to allow the different machine covers to be opened easily, leave a space of **at least 30 cm (12 inches)** on each side and at the back. Make sure that there is sufficient space in front of the machine.
- Never place the machine where it is under direct sunlight, heating radiators, air-conditioners, Avoid areas with frequent vibrations.
- Avoid areas where water or other products may be splashed on to the machine.
- Never place the machine directly on the floor.
- Always place the machine on a sturdy, flat surface.
- Always keep the machine away from hanging objects and any inflammable products.

## GP 10 Connections

### 3100MFP/X

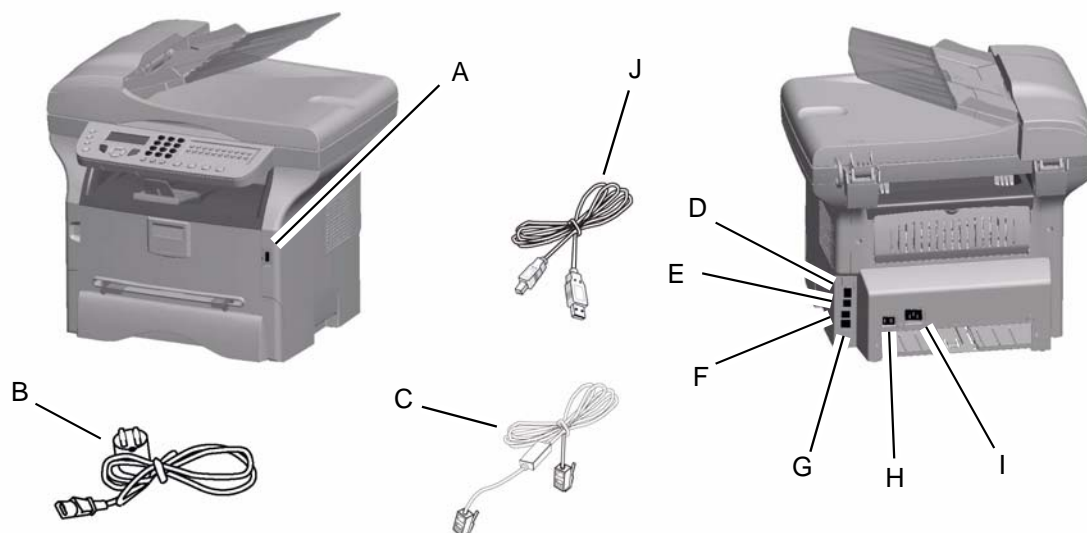
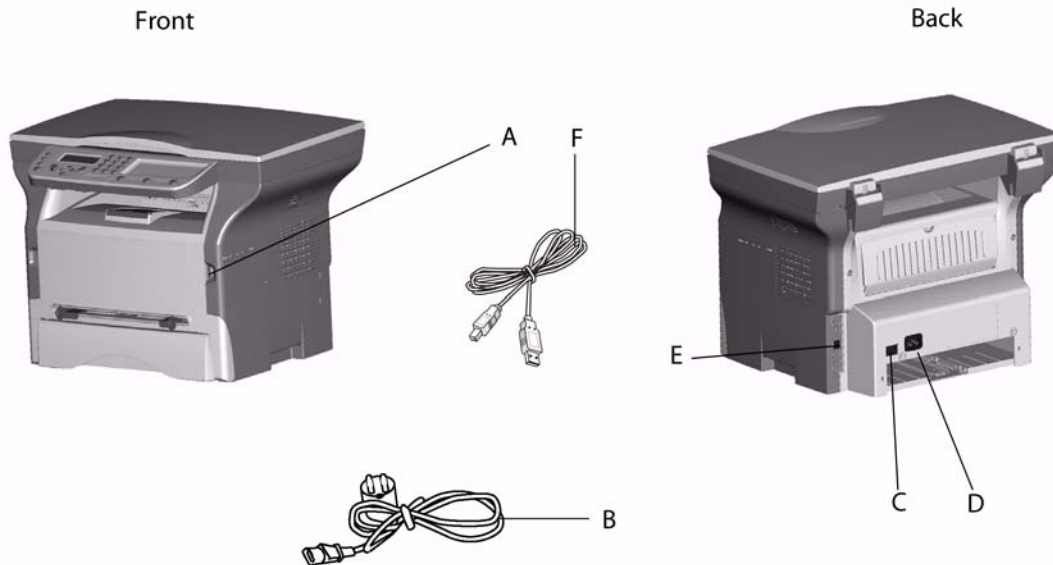

Figure 1

A	Master USB connection (USB key)
B	Power cord
C	Telephone cord (US only)
D	Master USB connection (USB key)
E	Slave USB connection (for PC)
F	EXT.socket - connection for external devices
G	LINE socket - telephone cable connection
H	On/Off switch
I	Power supply cord connection
J	USB cord

## 3100MFP/S



**Figure 2**

A	Master USB connection (USB key)
B	Power cable
C	On/Off switch
D	Power connection
E	Slave USB for PC
F	USB cable

### Phone Line Connection (3100MFP/X only)

1. Plug the end of the telephone line (C) into the terminal socket (G).
2. Plug the other end of the telephone line (C) into the wall telephone socket.

### PC Connections

Users can install and configure the machine on their PC as a local printer and scanner. There are two ways of connecting the machine to a PC:

- Via a USB connection,
- Via a WLAN connection.

This section only describes physical connections. Refer to the User Guide booklet for more information on configuring the machine to a PC.

## PC Connections Via USB

**Note:** Before connecting the machine to a PC, the Companion Suite software must be installed on the PC (Refer to the User Guide booklet for the detailed procedure).

1. Connect the end of the USB cable into the USB slave connector (**E**) located at the back of the machine.

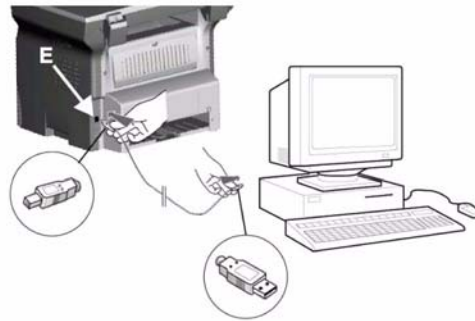

**Figure 1**

2. Connect the other end of the USB cable into a USB port on the PC.

## PC Connections Via WLAN

**Note:** Before connecting the machine to a PC, the WLAN connection and the Companion Suite software must be installed on the PC (Refer to the User Guide booklet for the detailed procedure).

1. Plug in the electronic WLAN key into the USB master connector (**A**) located at the front of the machine.



**Figure 2**

2. Connect the other end of the USB cable into a USB port on the PC.



## GP 11 Connecting the Power and Switching on the Machine

1. Make sure the machines On/Off switch (**H**) is positioned to Off (position 0).
2. Plug one end of the power cord (**B**) into the machines power socket (**I**), refer to [GP 10](#).
3. Plug the other end of the power cord (**B**) into the power supply wall socket.
4. Set the On/Off switch (**H**) to On (position I).

The machine powers on. After a few seconds, when the machine has warmed up, the Easy Install function is launched and the LCD screen displays the following message:

LANGUAGE

YES=OK - NO=C

Refer to the User Guide booklet for more information on carrying out the Easy Install initial setup.

## GP 12 Getting Started and Software Configuration

### User Parameters

Refer to the User Guide booklet for a detailed description of parameters available to the user.

### Installation Parameters

The installation parameters are used for configuring the machine to the specific requirements of users.

Each machine is programmed with the factory test configurations. The installer can obtain a printed copy of these parameters (sequence of keys ▼ 5 6).

**Note:** *It is recommended to conserve a paper copy of the list of parameters provided at delivery.* Access to these parameters is only authorized for the maintenance and/or installation service technicians.

The machine comes with software blocks called SOS (Soft Switches) N° 1 to 60. Each block is made up of 8 bits called bit 1 to 8. Each bit has a value of 0 or 1. Reading the block (from bit 1 to bit 8) on the display panel is done from right to left. The blinking cursor is always located on the bit 8 (on the extreme left) when selecting the configuration.

Access to the configuration bytes is available via the initialization screen, via a succession of keys:



The description of the principal configuration parameters for the machine are provided in the List of Configuration. They can be modified just like any other parameter.

## List of Configuration (SOS)

**Note:** The undocumented Soft Switches in this section are reserved.

### Soft-switch 1: Tuning the ringing tone and automatic printing (3100MFP/X)

Bit	Value	Description
1	1	Reserved
2	0	Reserved
3	0	SOS-DURPAUSE: Long/short pause while dialing Values: 0 (Short 2s) 1 (Long 6s)
4	0	Reserved
5	0	Reserved
6	1	SOS-IMPAUTO: Automatic log print Values: 0 (Without) 1 (With)
7	0	SOS-IMP30: Automatic printing of T30 trace after comm error Values: 0 (Without) 1 (With)
8	0	SOS-IMPTRA: Access to service functions Values: 0 (Without) 1 (With)

### Soft-switch 1: Tuning the ringing tone and automatic printing (3100MFP/S)

Bit	Value	Description
1	1	Reserved
2	0	Reserved
3	0	Reserved
4	0	Reserved
5	0	Reserved
6	1	Reserved
7	0	Reserved
8	0	SOS-IMPTRA: Printing of traces/authorization for PC download Values: 0 (Without) 1 (With)

### Soft-switch 2: Scanner/printer configuration

Bit	Value	Description
1	0	Reserved
2	0	Reserved
3	0	Emitting a beep tone when pressing a front panel key Values: 0 (with beep tone) 1 (without beep tone)
4	1	Reserved
5	0	Reserved
6	0	Reserved
7	0	SOS-COPLOC: Local copy Values: 0 (Enabled) 1 (Disabled)
8	0	Reserved

### Soft-switch 3: Line Configuration (3100MFP/X only)

Bit	Value	Description
1	1	SOS-NIVEMI: Transmission level
2	0	Values:
3	0	00 = 0 dBm
4	1	01 = -1 dBm ... 06 = -6 dBm ... 0F = -15 dBm
5	0	Reserved
6	0	SOS-SEUILREC: Reception threshold 1 Values: # 0 (-43 dB) 1 (-47 dB)
7	0	SOS - EPTV29: Use Echo Protect Tone with V29 Values: 0 (Without) 1 (With)
8	0	SOS - ECHO: Echo cancelling Values: 0 (Without) 1 (With)

**Soft-switch 4: Fax protocol configuration (3100MFP/X only)**

Bit	Value	Description
1	1	SOS-MODPRIV: Communication in private mode Values: 0 (Without) 1 (With)
2	0	SOS-DIS-COURT: Restricted DIS size Values: 0 (long DIS (complete)) 1 (Short DIS)
3	0	SOS-TCF: TCF accept criterion Values: 0 (Normal): refused if there has not been 1 continuous second. 1 (Special): 1 discontinuous second in the TCF, then accepted systematically at 2 400 b/s.
4	0	SOS-RTN: Page accept criterion
5	0	Values: 0 (10 percent) 1 (15 percent) 2 (20 percent) 3 (no check)
6	1	SOS-DISINF: Unlimited DIS length Values: 0 (Without) 1 (With)
7	0	SOS-LGINF: Maximum length of scan, printing, communication Values: 0 (1 meter) 1 (3 meters)
8	1	SOS-ECM: ECM Values: 0 (Without) 1 (With)

**Soft-switch 5: Voice/loudspeaker Configuration (3100MFP/X only)**

Bit	Value	Description
1	1	Reserved
2	0	Reserved
3	0	Reserved
4	0	Reserved
5	0	SOS-HP: Line monitoring during fax comm. Values: 0 (Without) 1 (With)
6	1	Reserved
7	1	Reserved
8	0	Reserved

**Soft-switch 6: Line adjustment (3100MFP/X only)**

Bit	Value	Description
1	0	Reserved
2	0	Reserved
3	0	Reserved
4	0	Reserved
5	0	Reserved
6	0	Reserved
7	0	Reserved
8	0	SOS-TSTDCOM: Driver com test functions Values: 0 (Without) 1 (With)

**Soft-switch 8: Remote readout/internal answering machine/modem (3100MFP/X only)**

Bit	Value	Description
1	0	SOS-TLR: Remote readout enable (ATTENTION!) Values: 0 (No remote readout) 1 (Remote readout enabled)
2	1	Reserved
3	1	Reserved
4	0	Reserved
5	1	Reserved
6	1	Reserved
7	0	Reserved
8	1	Reserved

**Soft-switch 9: Approval + communication applications (3100MFP/X only)**

Bit	Value	Description
1	0	Reserved
2	0	Reserved
3	0	Reserved
4	1	SOS-REPERR: Redialing from page fault Values: 0 (Without) 1 (With)
5	1	SOS-NOTREMIS: Printing of first page on transmission rapport Values: 0 (Without) 1 (With)
6	0	SOS-GRILLAGE: Burn phone numbers Values: 0 (Without) 1 (With)
7	1	SOS-LIGNE5S: Lines of 5 sec.during reception Values: 0 (Length of lines not limited to 5 sec./line) 1 (Maximum length of a line: 5 seconds)
8	1	Reserved

**Soft-switch 10: Communications: Locks/Miscellaneous (3100MFP/X only)**

Bit	Value	Description
1	0	SOS-AFFVIT: Communication rate display Values: 0 (Without) the page number is displayed. 1 (With) the comm. rate is displayed.
2	1	SOS-BTYPNUM: Access to impulse/DTMF parameter Values: 0 (With) Reserved 1 (Without)
3	0	Reserved
4	1	Reserved
5	1	SOS-TLRFAX: Remote readout by fax (ATTENTION!!!) Values: 0 (Remote readout to Quadrige in transparent mode) 1 (Remote readout by fax)
6	0	Reserved
7	0	SOS-SONREA: Access to redialing parameters (screen /printer) Values: 0 (No access) 1 (With access)
8	0	Reserved

**Soft-switch 18: Coding/UART Rate (3100MFP/X only)**

Bit	Value	Description
1	1	SOS-CODMEM: Stored document encoding type
2	1	Values: 00 (MMR Coding) 01 (MH Coding) 10 (MR Coding) 11 (JBIG Coding)
3	1	SOS-CODCOM: COM negotiated encoding type
4	1	Values: 01 (MH Coding) 10 (MR Coding) 11 (MMR Coding)
5	0	Reserved
6	0	Reserved
7	0	SOS-AFF_VIT_REELLE: Show/hide real communication rates Values: 0 (show reduced rates) 1 (show real rates)
8	0	Reserved



**Soft-switch 19: Miscellaneous software functions (3100MFP/X only)**

Bit	Value	Description
1	0	Reserved
2	1	Reserved
3	0	SOS-GROUPE: Restriction on groups (or distribution list) Values: 0 (No groups) 1 (Groups accepted)
4	0	SOS-REGULREC: T30 reception control inhibited Values: 0 (Without) 1 (With)
5	0	Reserved
6	1	SOS-MENUCLAUIER: Hide keyboard menus and force QWERTY keyboard Values: 0 (Show) 1 (Hide)
7	0	SOS-ONETOUCH: Enable "One touch" functions Values: 0 (Without) 1 (With)
8	0	SOS-TLC: Accept software download via Telephone line Values: 0 (Without) 1 (With)

**Soft-switch 21: T4 Decodeur/Debug (3100MFP/X only)**

Bit	Value	Description
1	1	SOS-TRAITLIGERR: T4 decoding line copying mode Values: 0 (For each line with an error) 1 (Only once, then destroy)
2	0	Reserved
3	0	Reserved
4	0	Reserved
5	1	Reserved
6	0	Reserved
7	0	SOS-DETECT OCCUP: Inhibition of engaged tone detect Values: 0 (Without) 1 (With)
8	0	Reserved

**Soft-switch 22: Miscellaneous (3100MFP/X only)**

Bit	Value	Description
1	1	SOS-DUREE-2100: Transmission time of the 2100 modified for V34 reception
2	1	Values: 00 (5 seconds) 01 (4.5 seconds) 10 (4 seconds) 11 (3.5 seconds)
3	0	Reserved
4	0	Reserved
5	0	Reserved
6	0	Reserved
7	0	Reserved
8	0	Reserved

**Soft-switch 23: Miscellaneous (3100MFP/X)**

Bit	Value	Description
1	1	SOS-JBIG: SUPER 3 capability to execute communication with JBIG encoding. Values: 0 (No SUPER G3) 1 (Negociated SUPER G3)
2	1	Reserved
3	0	Reserved
4	1	SOS-COMPACTE-RL: Compacting of run length (for fax server ELLIPSE) Values: 0 (No compacting) 1 (Compacting run length of no length)
5	0	SOS-DEBRIDAGE-JAUGE: Expectation of EEPROM cards at any moment. Values: 0 (No) 1 (Yes)
6	0	Reserved
7	0	Reserved
8	1	Reserved

**Soft-switch 23: Miscellaneous (3100MFP/S)**

Bit	Value	Description
1	1	Reserved
2	0	Reserved
3	0	Reserved
4	0	Reserved
5	0	SOS-DEBRIDAGE-JAUGE: Acceptance of EEPROM cards at any moment. Values: 0 (No) 1 (Yes)
6	0	Reserved
7	0	Reserved
8	1	Reserved

**Soft-switch 26: Miscellaneous (3100MFP/X)**

Bit	Value	Description
1	0	Reserved
2	0	Reserved
3	0	Reserved
4	0	Restriction on USB function Values: 0 (Without) 1 (With)
5	0	With or without duplication of on page passage threshold. Values: 0: No duplication: NBI_SUP_B (1cm) 1: Duplication: NBI_SUP_B * 2 (2 cm)
6	0	RR/RNR regulation limitation to 4 in T30. Values: 0: No limitation 1: With limitation
7	1	Double alternation optocoupler use Values: 0: Optocoupleur mono alternation 1: Optocoupleur double alternation
8	0	Reserved

**Soft-switch 26: Miscellaneous (3100MFP/S)**

Bit	Value	Description
1	0	Reserved
2	0	Reserved
3	0	Reserved
4	0	Restriction on USB function Values: 0 (Without) 1 (With)
5	0	Reserved
6	0	Reserved
7	0	Reserved
8	0	Reserved

**Soft-switch 27: Miscellaneous (3100MFP/X only)**

Bit	Value	Description
1	0	Reserved
2	0	
3	0	
4	1	
5	0	Waiting time before validation of unexpected modulation in comparison with expected modulation. (~driver/m_lucent/sms_m_dp2v/src/dpmain.c) 00 = 60 + 0*30 ms = 60 ms 01 = 60 + 1*30 ms = 90 ms 02 = 60 + 2*30 ms = 120 ms 03 = 60 + 3*30 ms = 150 ms 04 = 60 + 4*30 ms = 180 ms 05 = 60 + 5*30 ms = 210 ms 06 = 60 + 6*30 ms = 240 ms ..... 0F = 60 + 15*30 ms = 510 ms
6	0	
7	0	
8	0	

**Soft-switch 29: Miscellaneous (3100MFP/X only)**

Bit	Value	Description
1	0	Reserved
2	0	Reserved
3	0	Reserved
4	0	Force the V29 modulation for 9600 and 7200 rates #0: Enabled 1: Disabled
5	0	Reserved
6	0	Reserved
7	0	Reserved
8	0	Reserved

**Soft-switch 31: Miscellaneous**

Bit	Value	Description
1	0	Reserved
2	0	Reserved
3	0	Reserved
4	0	Displaying the TRASH CAN consumable (in the 86 menu) Values: 0 (Without) 1 (With)
5	0	Using the DHCP queries in ad-hoc WLAN mode Values: 0 (With) 1 (Without DHCP-directly APIPA)
6	0	Reserved
7	0	Reserved
8	0	Reserved

**Soft-switch 32: Miscellaneous (3100MFP/X only)**

Bit	Value	Description
1	0	Reserved
2	0	Reserved
3	0	Reserved
4	0	Reserved
5	1	Reserved
6	1	Reserved
7	0	Reserved
8	1	Reserved

**Soft-switch 33: Miscellaneous (3100MFP/X only)**

Bit	Value	Description
1	0	Reserved
2	0	Reserved
3	0	Reserved
4	0	Reserved
5	1	Question to the user about a good fax printing Values: # 0 (with) 1 (without question to user)
6	0	Reserved
7	0	Reserved
8	0	Reserved

## GP 13 Downloading the Software

Updating the machine software is principally carried out via a PC connection (**USB** only, see **PC connections**, page 7).

The principal software which controls the card core and the miniboot software may be downloaded separately.

**Note:** After downloading the principal software, the scanner may require calibration. Enter **▼ 8 0** and confirm by pressing **OK**. Wait until the screen refreshes and reverts to the default screen mode. Make a local copy to check its quality.

### Downloading via PC connection

#### Via the executable TELUSB2

This procedure requires a standard PC running under Windows and equipped with the TELUSB2.exe (version 2.02) executable and a USB cable.

**Before you start**, position the bit n° 8 to 1 on the Soft-switch 1.

1. Connect the machine to a PC with the USB cable.
2. Set the machine to download via PC mode (**▼ \* 4**).
3. Launch the executable **TELUSB2.EXE** and select the file to be downloaded (extensions.bin or.fwf).

After about ten seconds, a window will appear to indicate that the download was successful. The machine should not be restarted immediately.

If the machine restarts immediately, the file is corrupted (checksum false) or the software is not compatible with the machine. The machine then restarts with the initially installed software. In this case, check the file and repeat step 1.

4. After about 40 seconds, the machine switches off then restarts. The message **WAIT** is displayed.
5. Check the version of the principal software and checksum by typing in **▼ \* V** or check the software version and the miniboot's checksum by typing in **▼ \* B**.

#### Via the Update Device function of Companion Suite

This procedure requires a standard PC running under Windows equipped with the Companion Suite software and a USB cable.

**Before you start**, Check that the machine is connected to the PC via the USB cable.

1. On the PC, click **START >ALL PROGRAMS >COMPANION SUITE >PHASER 3100 MFP > UPDATE**.
2. In the Update window, click on the **BROWSE** icon and select the update file to be downloaded on the machine.
3. After selecting the update file, click on **OPEN**.
4. Click on **UPDATE**.

## Downloading with the miniboot

### Via the executable TELUSB2

This procedure requires a standard PC running under Windows and equipped with the TELUSB2.exe (version 2.02) executable and a USB cable.

**Before you start**, position the bit n° 8 to 1 on the Soft-switch 1.

1. Set the machine On/Off switch to Off (position 0).
2. Connect the machine to the PC via the USB cable.
3. Press the **4**, **6** and **0** keys simultaneously and set the On/Off switch to On (position I). The machine is switched on. The message **USB DETECTED WAITING FOR DOWNLOAD** is displayed and an alert sound is emitted. If the message **WAITING FOR A USB LINK** is displayed, check that the machine is properly connected to the PC via the USB cable.
4. Release the **4**, **6** and **0** keys.
5. Launch the executable **TELUSB2.EXE** and select the file to be downloaded (extensions.bin or.fwf).

After about ten seconds, a window will appear to indicate that the download was successful. The machine should not be restarted immediately.

If the machine restarts immediately, the file is corrupted (checksum false) or the software is not compatible with the machine. The machine then restarts with the initially installed software. In this case, check the file and repeat step 1.

6. After about 40 seconds, the machine switches off then restarts. The message **WAIT** is displayed.
7. Check the version of the principal software and checksum by typing in **▼ \* V** or check the software version and the miniboot's checksum by typing in **▼ \* B**.

### Via the UpdateDevice function of the Companion Suite

This procedure requires a standard PC running under Windows and equipped with the Companion Suite software and a USB cable.

**Before you start**, position the bit n° 8 to 1 on the Soft-switch 1.

1. Set the machine On/Off switch to Off (position 0).
2. Connect the machine to the PC via the USB cable.
3. Press the **4**, **6** and **2** keys simultaneously and set the On/Off switch to On (position I). The machine is switched on. The message **RECEIVING FILE** is displayed and an alert sound is emitted.
4. Release the **4**, **6** and **2** keys.
5. On the PC, click **START >ALL PROGRAMS >COMPANION SUITE >PHASER 3100 MFP >UPDATE**.
6. In the Update window, click on the **BROWSE** icon and select the update file to be downloaded on the machine.
7. After selecting the update file, click on **OPEN**.
8. Click on **UPDATE**.



## GP 14 Remote Readout

### CAUTION

*Before and after each service call on a machine equipped with the remote readout option, perform a manual transmission of the remote readout parameters to the service center, if the state of the machine allows it.*

All machines are equipped with the Remote Readout option (locked).

The option is unlocked by the installer or maintenance technician during the initial installation or during the intervention following the subscription of the contract.

When intervening on these machines, it is **very important** to proceed with care, because the remote readout parameters are verified by the processing centre in order to detect any anomalies, such as moving the machine, withdrawal, unintentional modification of the parameters, attempted fraud, etc.

At each automatic transmission, the Remote Readout parameters are transmitted in the night to the Server centre. A report of the transmission of these parameters is printed.

### Enabling the Remote Readout

The remote readout is enabled by means of a softswitch: bit 1 of SOS 8. The parameters can then be set by means of the hidden menu (key sequence ▼ \* 6). The essential parameters that trigger a remote readout are the interval in days and the page thresholds. Once the parameters have been entered, they can be consulted by means of the key sequence ▼ 8 7 1 and printed by means of the key sequence ▼ 8 7 2.

The transmission mode of the remote readout can be selected by means of another softswitch, bit 5 of SOS 10, which can be set to 1 for conventional fax transmission and 0 for transparent mode.

### Trigger Criteria

The remote readout can be triggered by two types of criteria: “day” or “threshold”.

The “day” criterion is based on the “interval in days” parameter entered in the remote readout menu accessible by means of the key sequence ▼ \* 6. This parameter represents the interval at the end of which a remote readout is transmitted. If the parameter has been set to 30, a remote readout will be transmitted every 30 days. This parameter cannot exceed 365 days. A transmission using the day criterion allows the server centre to regularly monitor its installed base of machines and to detect any anomalies that may occur. The remote readout using the day criterion can be disabled by entering an interval of zero.

The “threshold” criterion is based on the page thresholds entered in the remote readout menu accessible by means of the key sequence ▼ \* 6. When a consumables counter drops below the corresponding threshold, the remote readout is triggered. For instance, if the toner threshold is set to 1500 pages, a remote readout will be transmitted when the toner counter drops below 1500, or in other words, when the remaining toner allows no more than 1500 pages to be printed.

These counters cannot be read directly, however, they can be calculated easily by means of the percentages displayed in the advanced functions menu (key sequence ▼ 8 6), relative to the initial number of pages for the consumable (as shown in the remote readout report). If, for instance, the

initial number of pages for the consumable is **8000** and the threshold is set to **2000** pages, the remote readout will be triggered when the corresponding percentage drops below 25%.

The remote readout using the threshold criterion can be triggered only once per consumable. Once the remote readout has been transmitted, the criterion will no longer be tested until the consumable has been replaced.

The transmissions triggered by the two criteria (thresholds and day) are independent of each other. I.e., as soon as one of the criteria is met, the transmission is triggered, irrespective of the state of the other parameters. The transmission is immediate.

It is also possible to force a transmission manually by means of the **advanced functions** menu (key sequence ▼ **8 7 3**).

### Initial Consumables (print cartridge)

On a new machine, the consumables are activated by reading an initial EEPROM card. The consumables present in the machine at that time are referred to as the initial consumables. In this case, regardless of the thresholds entered in the **advanced functions** menu (key sequence ▼ \* **6**), for each consumable the first remote readout will be triggered on the base of a threshold criterion of 1000 pages. After this, when the consumable has been replaced and after reading the EEPROM card, the machine switches to the standard remote readout mode as described earlier.

### Description of the Transmitted Data

#### Format of transmitted data in transparent mode

When a criterion is met, a transmission in transparent mode is generated (the softswitch SOS 10 bit 5 must have been set to 0). The structure of the transmitted file is of the type TLV (Type - Length - Value).

The transmitted data are defined below, with for each item: its identifier (TLV "type"), its format (numerical or character string) and its origin (entered by the operator or generated by the software).

These parameters, which are also present in the transmission report, will be described further on.

Field	Type	Char. / Num.	Manual entry
TVERS_TLR	0x00	char	No
TNO_23MIL	0x01	char*	Yes
TNO_SERIE	0x02	char*	Yes
TNO_CLIENT	0x03	char*	Yes
TNO_VERSION	0x04	char*	No
TINDICATIF	0x05	char*	Yes
TIDENTIFIANT	0x06	char*	Yes
TNO_SERVEUR	0x08	char*	Yes
TCAUSE_EMIS	0x09	uchar	No
TNOMRESP	0x10	char[15]	Yes
TSOCIETE	0x11	char[15]	Yes
TADRESSEL1	0x12	char[30]	Yes
TADRESSEL2	0x13	char[30]	Yes
TADRESSEL3	0x14	char[30]	Yes
TCODEPOSTAL	0x15	char[15]	Yes
TVILLE	0x16	char[30]	Yes
TPAYS	0x17	char[15]	Yes
TLANGUE	0x18	char[15]	Yes
TTELEPHONE	0x19	char[30]	Yes
TDATE_EMIS	0x21	char*	No
T_CPT_PAGES	0x40	long	No
T_CRIT_JOURS	0x42	long	Yes
T_CPT_PAGES_JOURS	0x43	long	No
T_DATE_SEUIL_JOURS	0x45	char*	No
T_INIT_NOIR	0x46	long	No
T_CPT_NOIR	0x47	long	No
T_SEUIL_NOIR	0x48	long	Yes
T_DATE_SEUIL_NOIR	0x49	char*	No
T_DATE_CHG_NOIR	0x4a	char*	No
T_INIT_OPC	0x5a	long	No
T_CPT_OPC	0x5b	long	No
T_SEUIL_OPC	0x5c	long	Yes
T_DATE_SEUIL_OPC	0x5d	char*	No
T_DATE_CHG_OPC	0x5e	char*	No

The values of the field TCAUSE\_EMIS (reason for transmission) are the following:

- Interval days 2
- Manual send 3
- Toner 4

The initial values of the page counters for a new print cartridge is T\_INIT\_NOIR.

## Remote Readout Report

For each transmission a remote readout report is printed. It contains all the data that has been transmitted to the service center in transparent mode. In the case of a transmission in fax mode, the fax that is received is identical to this report.

The report uses the presentation shown below:

```

** PARAMETRES DE TELERELEVE **

INFORMATIONS GENERALES

Numéro 23 millions      :XXXXXXXXXX
Numéro de série        :XXXXXXXXXX
Numéro compte client   :XXXXXXXXXX
Numéro de version     :XXXXXXXXXX
Numéro                 :XXXXXXXXXXXXXXXXXX
Nom                    :XXXXXXXXXXXXXX
Centre serveur        :XXXXXXXXXXXXXXXXXX
Nom de la personne responsable :XXXXXXXXXXXXXXXXXX
Société                :XXXXXXXXXXXXXXXXXX
Adresse                :XXXXXXXXXXXXXXXXXXXXXXXXXXXXXXXXXXXX
Adresse                :XXXXXXXXXXXXXXXXXXXXXXXXXXXXXXXXXXXX
Adresse                :XXXXXXXXXXXXXXXXXXXXXXXXXXXXXXXXXXXX
Code postal            :XXXXXXXXXXXXXXXXXX
Ville                  :XXXXXXXXXXXXXXXXXXXXXXXXXXXXXXXXXXXX
Pays                   :XXXXXXXXXXXXXXXXXX
Langue                 :XXXXXXXXXXXXXXXXXX
Téléphone              :XXXXXXXXXXXXXXXXXXXXXXXXXXXXXXXXXXXX

INFORMATIONS DE GESTION

Statut de l'imprimante  Nombre de pages : XXXXX
Intervalle jours:      Intervalle jours : XXXX
                       Précédente télérélevé le JJ/MM/AA HH :MM
                       - Nombre de pages = XXXXX

Toner:                 Nombre estimé de page: XXXXXSeuil pages : XXXXX
                       Précédente télérélevé le JJ/MM/AA hh:mm (XXXX pages)
                       Dernier renouvellement le JJ/MM/AA hh:mm

INFORMATIONS EMISSION

Cause émission : XXXXXXXX XXXXXXX
Heure émission : JJ/MM/AA hh:mm

```

Figure 3

## Description of the Parameters

The different fields shown in the report are described below.

### General Information

- (TNO\_23MIL): the 23M of the module managed by the service center, entered by the installer;
- (TNO\_SERIE): the identification of the machine, entered by the installer;
- (TNO\_CLIENT): the identification of the contract, entered by the installer;
- (TNO\_VERSION): generated automatically;
- (TINDICATIF): the machine number, entered by the installer;
- (TIDENTIFIANT): the machine name, entered by the installer;
- (TNO\_SERVEUR): the phone number of the service center or of the fax, entered by the installer.
- (TNOMRESP): the name of the person responsible for the machine, entered by the installer.
- (TSOCIETE): the name of the company who owns the machine, entered by the installer.
- (TADRESSEL1, TADRESSEL2 et TADRESSEL3): postal address of the machine, entered by the installer.
- (TCODEPOSTAL): entered by the installer.
- (TVILLE): entered by the installer.
- (TPAYS): entered by the installer.
- (TLANGUE): entered by the installer.
- (TTELEPHONE): entered by the installer.

### Printer Status

- T\_CPT\_PAGES): the cumulative total number of pages printed since the installation of the machine.

### Interval in Days

- (T\_CRIT\_JOURS): the trigger interval using the day criterion (0 if the criterion is not active), entered by the installer;
- (T\_DATE\_SEUIL\_JOURS): date of the last remote readout triggered by the day criterion, or installation date if there has not been any previous remote readout;
- (T\_CPT\_PAGES\_JOURS): value of the cumulative number of pages printed at the date of the previous remote readout triggered by the day criterion (or 0 if there has not been any previous remote readout).

### Toner

- (T\_INIT\_NOIR): theoretical capacity of the cartridge estimated in average pages;
- (T\_SEUIL\_NOIR): trigger level (expressed as the number of pages remaining to be printed) for the transmission of a remote readout triggered by the toner threshold criterion, entered by the installer;
- (T\_DATE\_SEUIL\_NOIR): date of the last remote readout triggered by the toner threshold criterion, or installation date if there has not been any previous remote readout;
- T\_CPT\_NOIR): theoretical number of pages remaining to be printed at the instant of the triggering of the previous remote readout by the toner threshold criterion (or 0 if there has not been any previous remote readout);

- (T\_DATE\_CHG\_NOIR): date of the last replacement of the print cartridge.

### Transmission Data

- (TCAUSE\_EMIS): reason for the remote readout transmission;
- (TDATE\_EMIS): date of the transmission of the remote readout.

### Reminders

- Every machine is equipped with a copy counter, implemented in EEPROM memory on the CPU board. This counter is used in particular by the Remote Readout function. It can be consulted by the user (see § 5 of the User booklet). This counter cannot be modified. It is stored indefinitely.
- Before any service on the machine that risks modifying the installation parameters or the value of the counter (replacement of the CPU board or installation of new software), a manual Remote Readout transmission should be performed, if the state of the machine allows it. If this transmission is not possible for any reason, print out the Remote Readout parameters or display the copy counter and note these values on the service report.

## GP 15 Storing User Parameters And Activity Counters On The Machine

The condition of the printer consumable (print cartridge) is stored in EEPROM memory (on the CPU card) and can be read via the command ▼ **8 6**. This evaluation, provided in percentage format, indicates the remaining quantity of toner in relation to the consumable's initial values.

The printer activity counters are also stored in flash (on the CPU card), they can be read via the command ▼ **8 2** and can be printed via ▼ **5 6** (printing of parameters). These absolute counters reflect the machine's overall utilization regardless of the consumable:

- number of pages sent (3100MFP/X only),
- number of pages received (3100MFP/X only),
- number of pages printed,
- number of pages scanned.

### CAUTION

*Any major service on the machine (replacement of the CPU card, major upgrade of the machine software) may lead to the permanent loss of the user parameters and the activity counter values.*

**Note:** *If such operations are necessary, print the parameters and counters (▼ 5 6) to retain a copy. You can also store user parameters and directory entries on a smart card (▼ \* 6) and restore them (▼ \* 9) after the machine is serviced.*

## GP 16 Packing and Transporting the Machine

If you need to transport the machine, always use the original package. If the machine is not properly packed, the warranty may be cancelled. Also check that the machine new location meets the installation requirements, [GP 9](#).

1. Set the machine On/Off switch to Off (position 0).
2. Disconnect all the cables connected to the machine.
3. Remove the document feeder and gently push the paper tray inwards to avoid obstructing the machine packaging.
4. Pack the machine in its original plastic wrapping and put it in its original packing box together with the other components (power cord, etc.).
5. Pack all documentation (manuals and printed documents) into the packing box and seal it with adhesive tape.

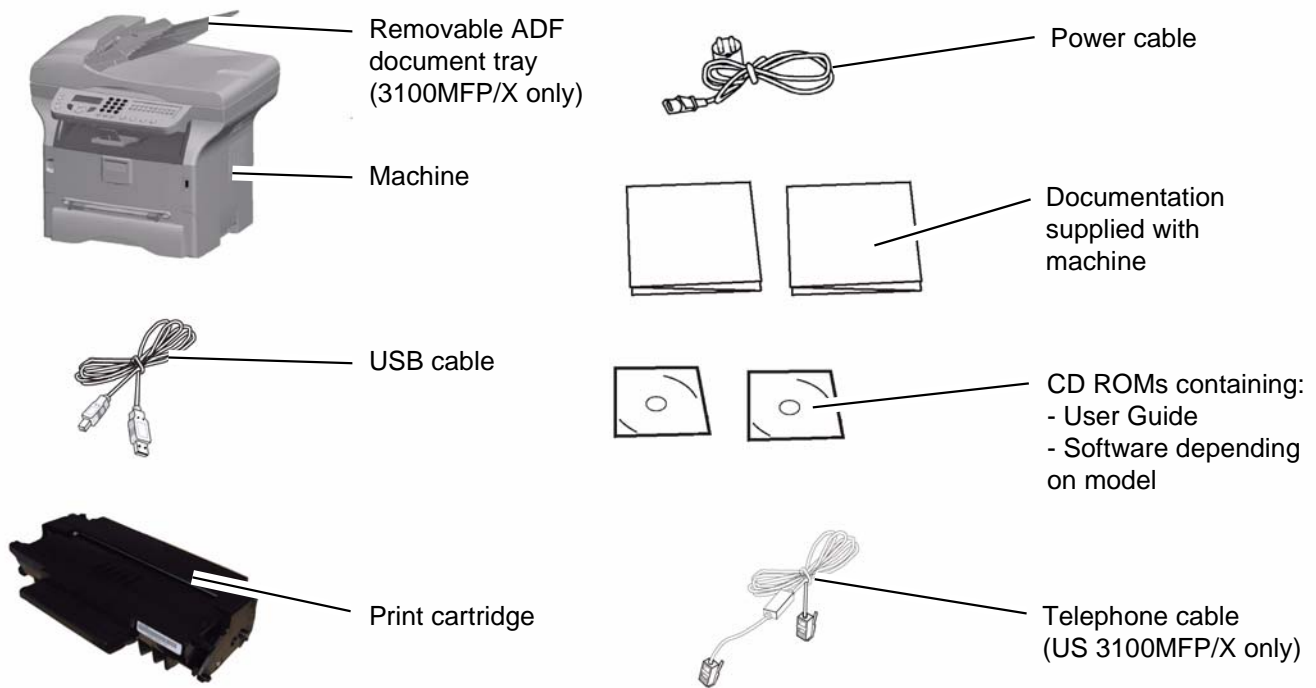

Figure 1



## GP 17 Administrator Functions

Each one of the administrator functions described here is accessible via a specific sequence of keys. The alphabetic keys are available via the navigation keys ▼ and ▲ via the keyboard. For example, to enter a sequence ▼ \* A (launching scanner calibration):

1. Press the following key ▼
2. Press the following key \*.
3. Press ▼ to display all the options available until you reach A. Confirm your choice with **OK**.

### Initializing and Erasing Memory

Before you start, set the 8 bit parameter installation configuration 1 to 1.

#### CAUTION

*Undocumented functions are reserved. Do not try and use functions that are not documented in this section, this may lead to the permanent loss of data.*

#### CAUTION

*Undocumented functions are reserved. Do not try and use functions that are not documented in this section, this may lead to the permanent loss of data.*

- Reset all parameters (user, installer or technical) to the default configuration (factory configuration):

▼ (#) (0)

- Erase the directory:

▼ (#) (1)

- Erase the logs:

▼ (#) (2)

- Erase the printer counters:

▼ (#) (3)

- Reinitialize the flash data (erases all):open the printer front door then:

▼ (#) (5)

- Erase all. Reset to default configuration (combination of functions 0 and 8):

▼ (#) (7)

## General Procedures and Information

---

- Erase all documents stored in memory:



- Erase the first job in the print queue:



- Erase Printer Error:



Then switch ON/OFF the machine.

## Other Functions

Some of the administrator functions allow you to display or print the machine counters. The table below details the counters available:

The counter...	lists the number of...
Sent pages counter (3100MFP/X only)	pages sent
Received pages counter (3100MFP/X only)	pages received
Printed pages counter	pages printed
Scanned pages counter	pages scanned
Printed sheets counter	paper sheets printed
Printer does not grip the sheet	no-paper feeds detected on the printer
Jam in printer	paper jams detected inside the printer
Jam in printer output	paper jams detected on the exit tray
ADF misfeed (3100MFP/X only)	no-paper feeds detected on the ADF scanner
ADF jams (3100MFP/X only)	paper jams detected in the ADF scanner
07 Error in fax transmission (3100MFP/X only)	code 07 errors detected during fax transmission (busy or no fax answer)
01 Error in fax transmission (3100MFP/X only)	code 01 errors detected during fax transmission (disconnections)
Other errors in fax transmission (3100MFP/X only)	any other error codes detected during fax transmission
64 Error in maintenance transmission (3100MFP/X only)	code 64 errors detected during remote readout
07 Error in fax reception (3100MFP/X only)	code 07 errors detected during fax reception (busy or no fax answer)
Vocal call in fax reception (3100MFP/X only)	voice calls detected during fax reception
Other errors in fax reception (3100MFP/X only)	any other error codes detected during fax reception
Other errors in IP communication (3100MFP/X only)	error codes detected during IP communication (connection loss)
Manual and automatic ON/OFF	times the machine has been switched On/Off (manually and automatically)
Insert toner card	toner card readings
Pixel number (*10000)	pixels the machine has printed (*10000)
Counter TONER	toner remaining in toner units

**Before you start**, position the Soft-switch 1 bit n°8 to 1.

**CAUTION**

*Undocumented functions are reserved. Do not try and use functions that are not documented in this section, this may lead to the permanent loss of data.*

- Printing all parameters (including installation and technical parameters):



- Switching to forced standby mode regardless of the clock:



- Switching to software download via a computer link:



- Save the directory and parameters on I2C card:

**CAUTION**

*All data present on the i2c card prior to the operation will be lost after operation and replaced by directory and parameters from the machine*



- Restore the directory and parameters from I2C card:

**CAUTION**

*All directory contents and parameters stored in the machine prior to the operation will be lost after operation and replaced by those from the i2c card.*



- Launching scanner calibration:



- Displaying miniboot version:



- Displaying the state of the applications, traffic and drivers:



- Display modem software version:



- Entering the serial number (with the SOS 1 bit 8 at 1):



- Displaying the internal counters:



- Displaying the GDI throughput:



- Rebooting the machine manually (with the SOS 1 bit 8 at 1):



- Displaying main software version, checksum:



- Displaying the printer firmware version and the 120V/220V configuration:



- Depending on the printer model, the machine LCD screen displays:

PRINTER FIRMWARE  
Vx.x 120V

or

PRINTER FIRMWARE  
Vx.x 220V

- Printing internal counters:



# GP 18 Component Layout

## Mechanical Components

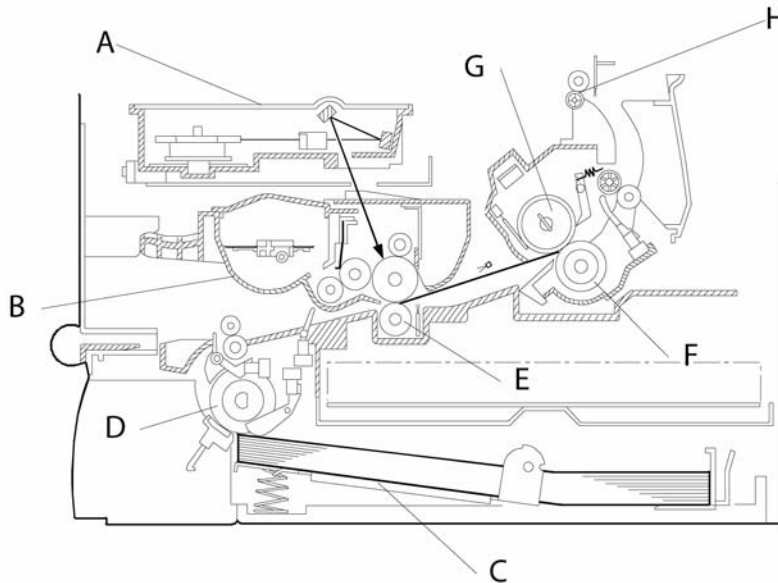

**Figure 1**

**Table 1:**

No.	Name	Description
A	Laser Unit	Consists of the laser diode unit, cylindrical lens, f-theta lens, polygon mirror motor, and other laser optical components.
B	Toner Cassette	Consists of the OPC drum, toner, toner application roller, development roller, charge brush roller, cleaning blade, and other development components.
C	Upper Tray Bottom Plate	Presses paper stacked in the upper paper tray against the paper feed roller.
D	Paper Feed Roller	Picks up the top sheet of paper from the stack in the upper paper tray and feeds it into the transfer area.
E	Transfer Roller	Applies a charge to the paper to pull the toner off the drum and onto the copy paper.
F	Pressure Roller	Applies pressure to the paper during fusing.
G	Heat Roller	Fuses the toner to the copy paper.
H	Paper Exit Roller	Feeds the paper out of the printer.

## Printing

### Printing Processes Around the Drum

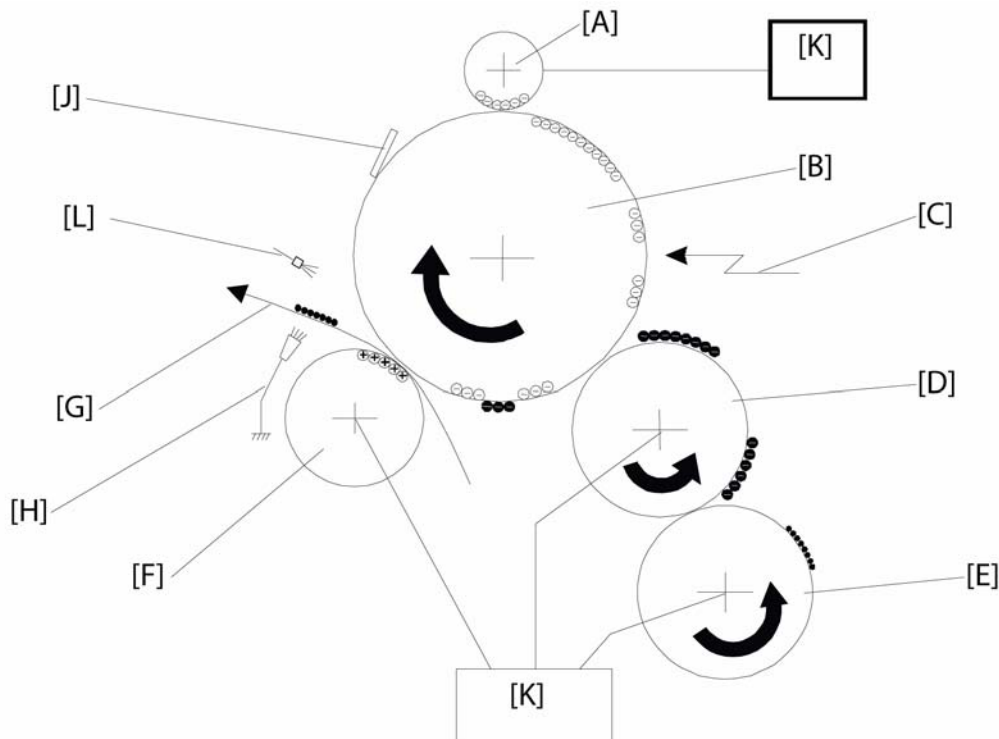

**Figure 2**

This machine uses a “write to black” system, using negative toner.

**Charge:** The charge brush roller [A] gives the OPC drum [B] surface a negative charge.

**Exposure:** A laser [C] writes a latent image on the drum. The charge in the area exposed by the laser beam drops.

**Development:** The development roller [D] carries toner to the drum and develops the latent image on the drum. The following charges are applied. **Development bias (during printing):** Toner application roller [E] Development roller [D] **Switching bias (At the start and the end of any print process):** Toner application roller [E] Development roller [D]

**Image Transfer:** The transfer roller [F] pulls the toner from the drum onto the paper [G].

**Paper Separation:** The antistatic brush [H] removes the charge on the underside of the paper to help the paper separate from the drum.

**Drum Cleaning:** The Discharge Lamp [L] discharge the OPC drum [B] surface, The cleaning blade [J] removes any toner remaining on the drum after the image is transferred to paper.

The high voltages [K] are supplied from the Power Supply Unit board.

## Charge

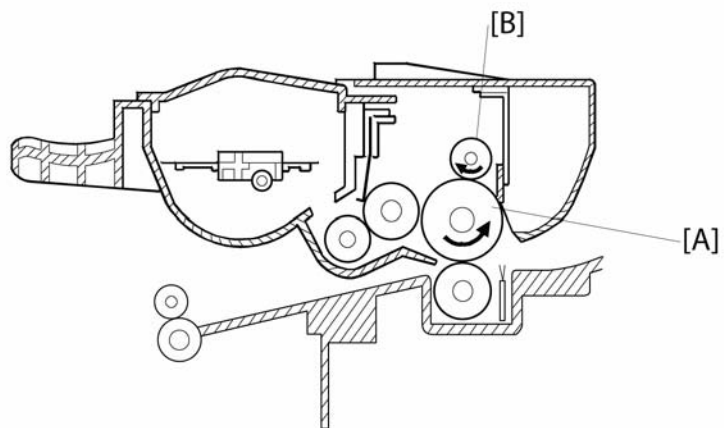
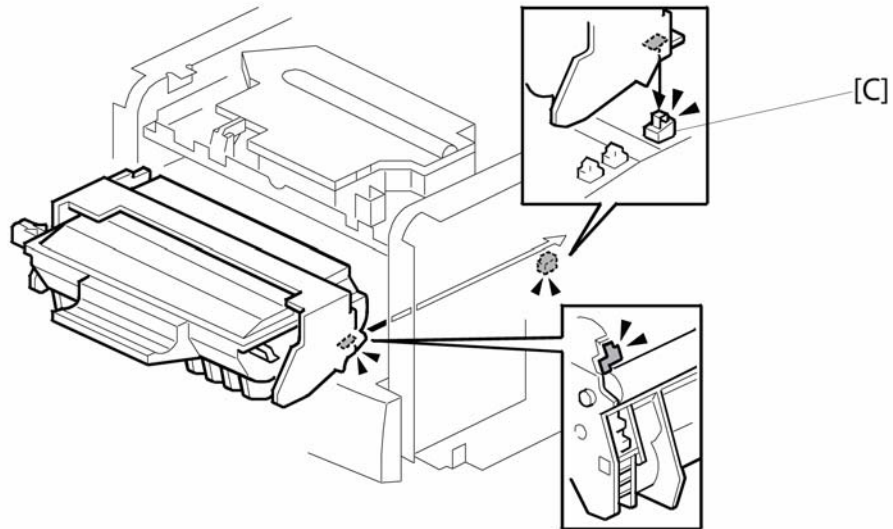

**Figure 3**

The OPC (Organic Photoconductor) drum [A] used in this machine is small in diameter. This allows a very compact design.

A charge roller [B] charges the photoconductor. The charge roller has the advantage of not generating ozone. A large negative voltage is applied from the Power Supply Unit board to the charge roller. This charge roller gives the OPC drum surface a negative charge.





**Figure 4**

The voltage to the charge roller is supplied through the terminal [C] from the Power Supply Unit board.

## Laser Exposure

### Overview

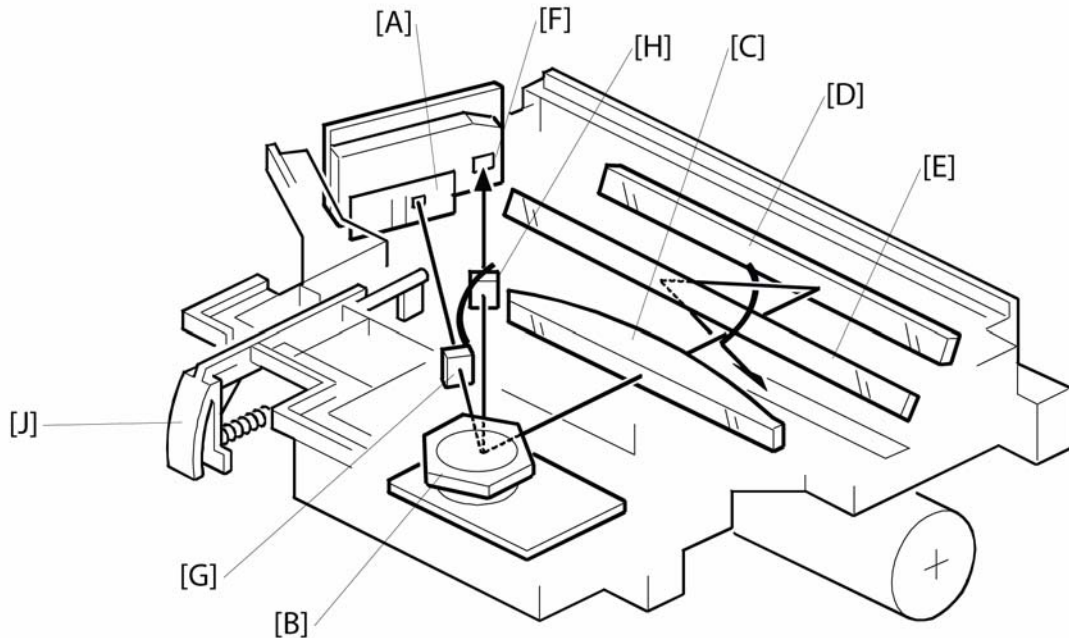

Figure 1

### Laser Unit Layout

- A: Laser Diode Unit
- B: Polygon Mirror Motor
- C: F-theta Lens
- D: First Mirror
- E: Second Mirror
- F: Laser Synchronization Detector
- G: Cylindrical Lens
- H: Synchronization Detector Lens
- J: Shutter

This machine uses a laser diode to produce an electrostatic latent image on the OPC drum. The laser diode unit converts image data into laser pulses, and the optical components direct these pulses to the OPC drum.

As a mechanical safety feature, the shutter [J] closes to block the laser beam path whenever the front door is opened.

## Block Diagram

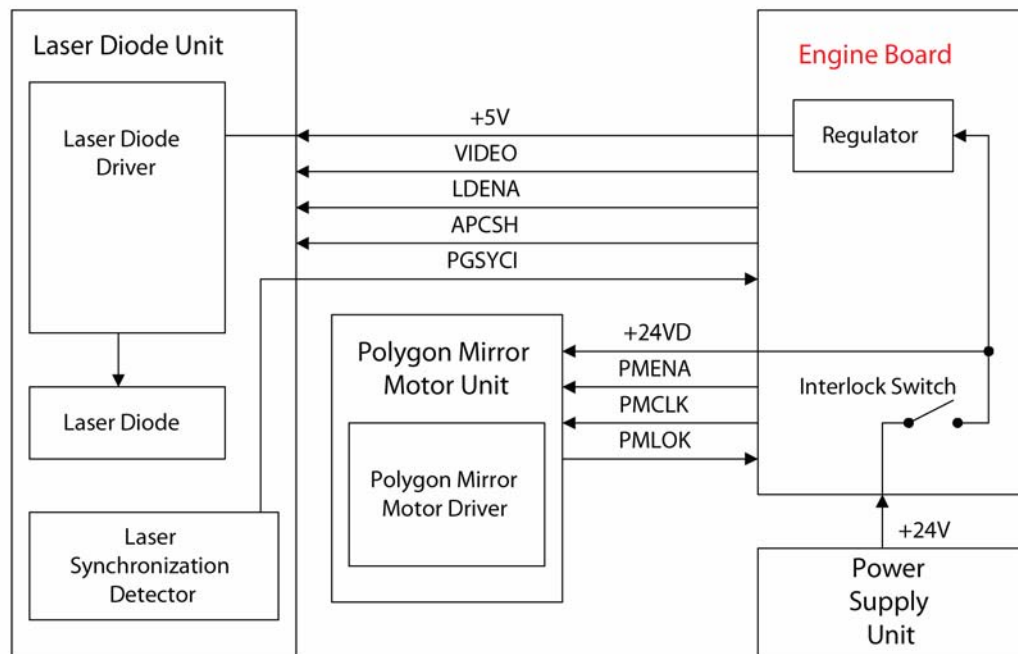

**Figure 2**

The Engine Board controls the laser diode power (APCSH) and transfers data for printing to the laser diode (VIDEO). As an electrical safety feature, there is an interlock switch on the Engine Board. This switch cuts +24 volts whenever the front door is opened.

## Error Conditions

### Laser Error

The machine detects laser synchronization signal pulses (PGSYCI) 70 milliseconds after the (LDENA) signal is sent. It detects a laser error if the pulse count does not reach the specified number within 400 milliseconds.

When this occurs, the machine displays an error on the LCD panel (Error 56).

### Polygon Mirror Motor Error

The machine detects a polygon mirror motor error when the (PMLOK) signal does not go low within 3.5 seconds of the (PMENA) signal. When this occurs, the machine displays an error on the LCD panel (Error 57).

## Development

### Overview [D]

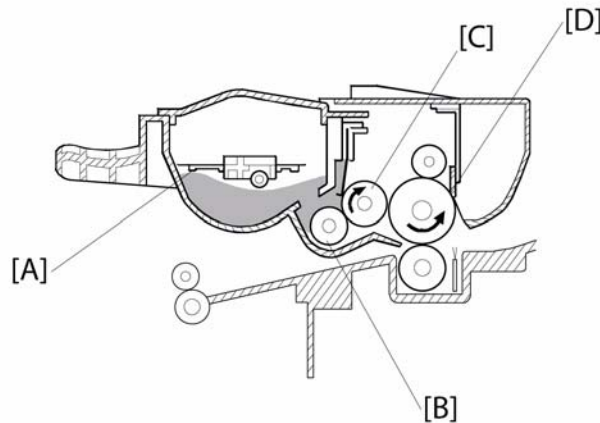
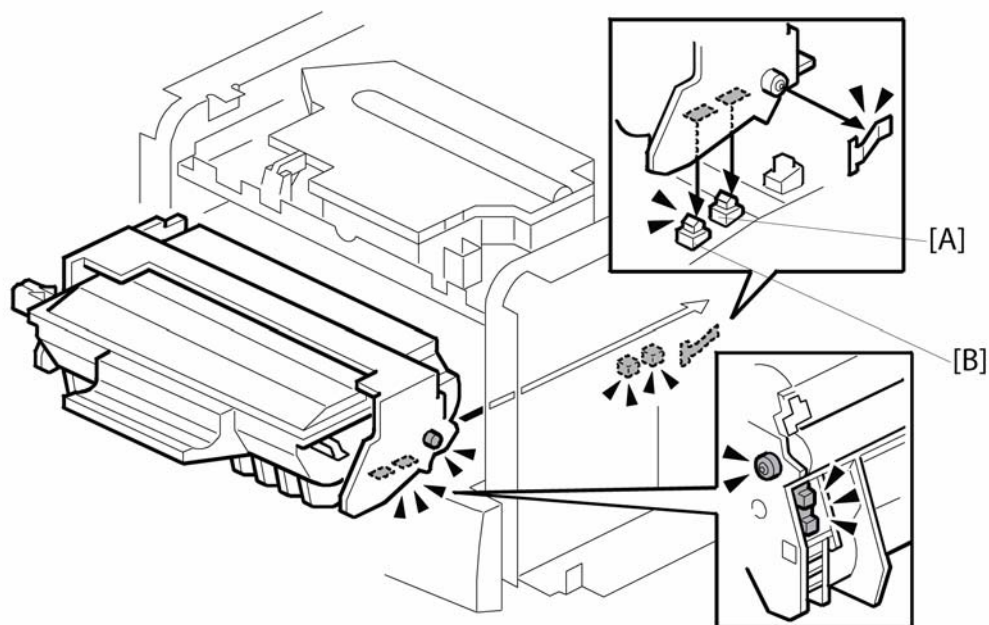

**Figure 3**

This machine uses mono-component toner, which is composed of resin and ferrite. The toner mixing bar [A] stirs and carries toner to the toner application roller [B]. The toner application roller supplies toner to the development roller [C]. As the development roller turns past the toner metering blade [D], only a thin coating of negatively charged toner particles stays adhered to the development roller.

During printing, a bias voltage is applied to the toner application roller and another bias voltage is applied to the development roller. The toner is transferred from the toner application roller to the development roller by the potential difference between these two rollers.

The development roller applies toner to the exposed areas of the latent image as they turn past the drum.



**Figure 4**

The voltage to the development roller and the toner application roller is supplied through the terminals ([A] for the development roller and [B] for the toner application roller) from the Power Supply Unit board.

#### **Toner End Detection**

This machine does not have toner end detection.

## Transfer and Separation

### Overview

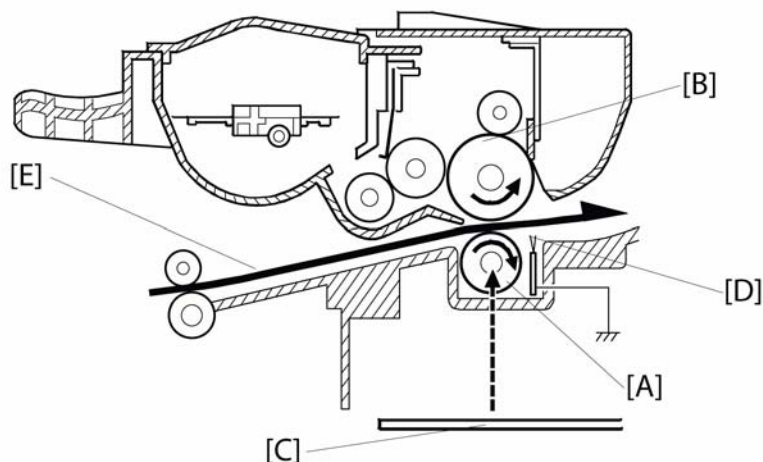

**Figure 5**

This machine uses a transfer roller [A], which touches the OPC drum [B] surface. A constant current is applied to the transfer roller from the power supply unit board [C]. The positively-biased transfer roller pulls negatively-charged toner off the drum.

The curvature of the drum, and the antistatic brush [D], help the paper [E] to drop away from the drum.

### Cleaning Mode

If a paper jam occurs during printing, toner may be transferred to the transfer roller surface. To prevent this toner from transferring to the underside of the paper, the transfer roller must be cleaned before the next printing run.

While the machine is in the cleaning mode, the Power Supply Unit board applies a negative voltage to the transfer roller.

The negatively charged toner on the transfer roller is then transferred back to the drum.

The machine goes through the cleaning mode at the following times.

- At power-up: The process starts when the fusing temperature reaches the standby temperature.
- When the cover is opened and then closed during the printing process.
- After a printer jam has been cleared.

## Drum Cleaning

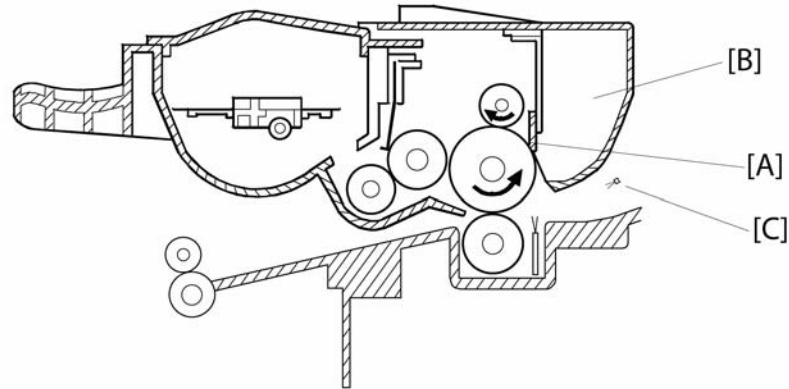

**Figure 6**

The cleaning blade and the used toner tank are contained in the print cartridge. The Discharge Lamp and A counter blade system is used for drum cleaning. The Discharge Lamp [C] discharge the drum surface. The cleaning blade [A] removes any toner remaining on the drum after the image is transferred to the paper. This removed toner is stored in the used toner tank [B].

There is no used toner overflow detection mechanism, because the used toner tank is large enough for the lifetime of the toner cassette.

## Paper Feed and Registration

### Overview

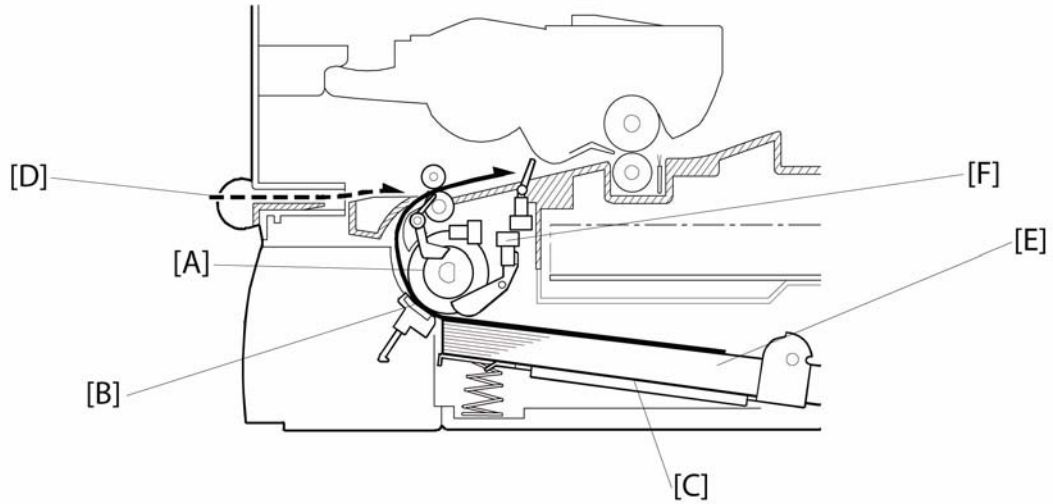
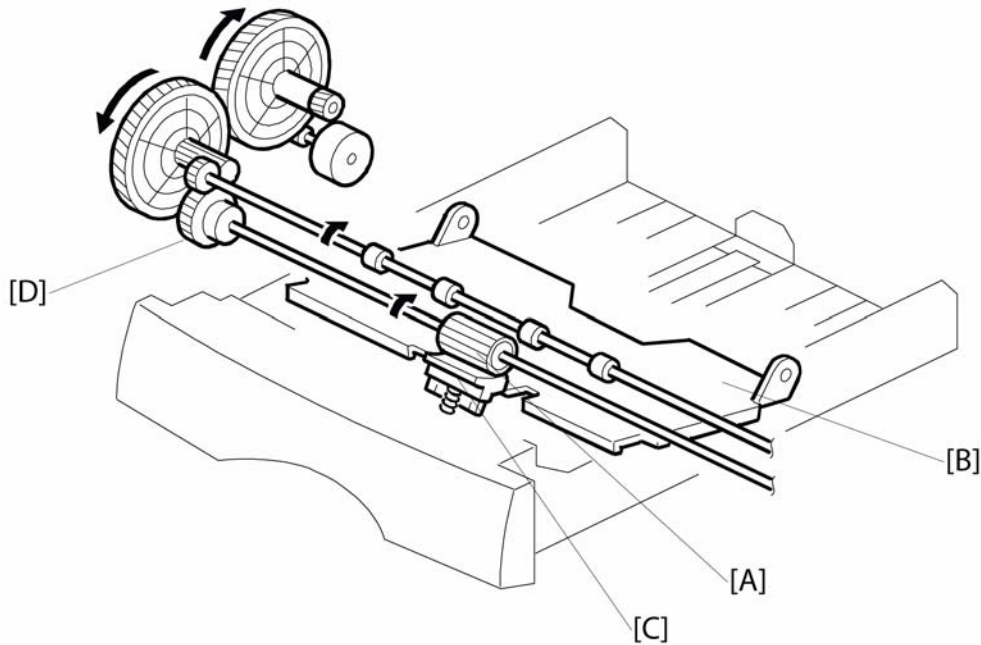

**Figure 7**

Paper Feed System:	Feed roller [A] and Friction pad [B]
Paper Lift Mechanism:	Bottom plate with spring [C]
Sheet feeder	1 sheet feeder [D]
Tray Capacity:	250 sheets [E]
Paper End Detection:	Paper end sensor [F]
Paper Size Detection:	None



## Paper Feed Drive Mechanism



**Figure 8**

The feed roller [A] is located above the upper tray bottom plate [B], and the friction pad [C]. It allows only one sheet to feed from the paper tray. They are controlled by the paper feed clutch [D]. The registration sensor detects the leading edge of the paper and synchronizes paper feed with the activation of the laser diode to write the image on the OPC drum.

## Paper Feed Operation

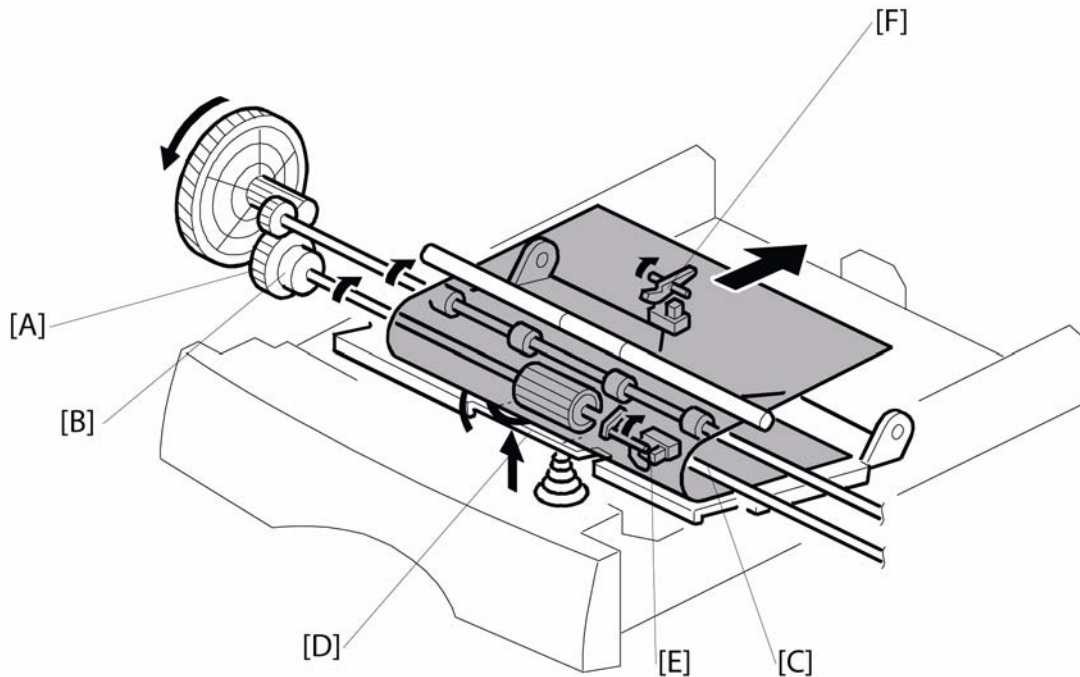

**Figure 9**

- A: Paper feed drive gear
- B: Paper feed clutch
- C: Paper feed roller
- D: Friction pad
- E: Paper feed sensor
- F: Registration sensor

The paper feed drive gear [A] always rotates while the main motor rotates, since the paper feed clutch (magnet clutch) [B] is energized to turn the paper feed roller [C].

When the paper feed clutch [B] is energized to turn the feed roller, the paper feed roller feeds one sheet of paper from the tray. The paper is fed into the machine by the registration roller.

## Registration

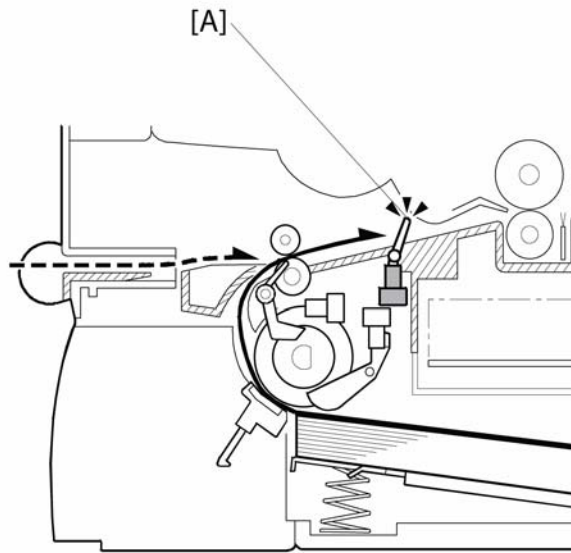

**Figure 10**

The registration sensor [A] detects the leading edge of the paper and synchronizes paper feed with the writing of the image on the drum, so that the image and paper match up properly. This sensor also detects paper feed jams.

## Tray Empty Sensor

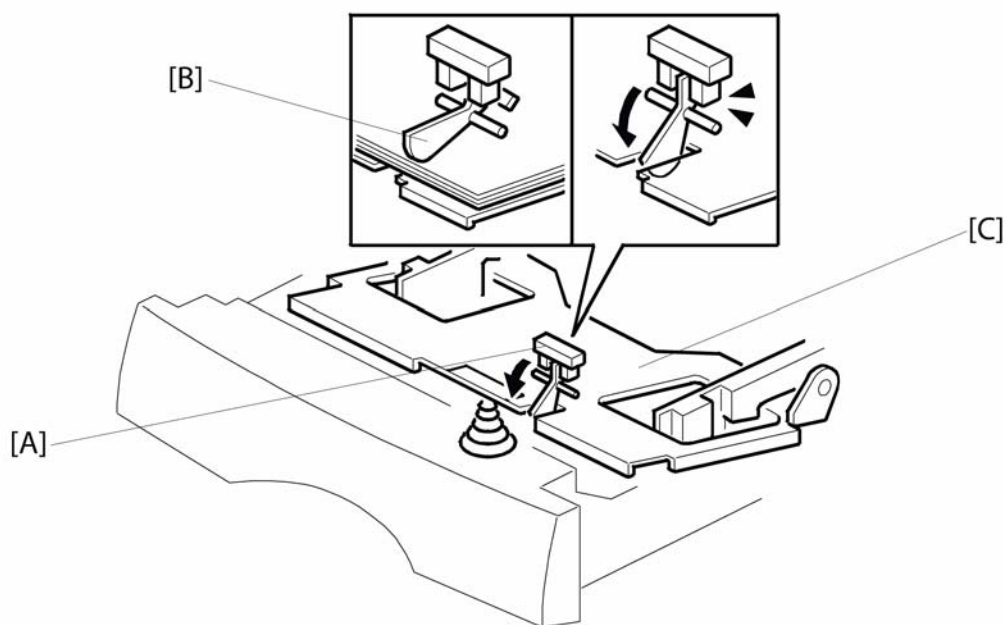
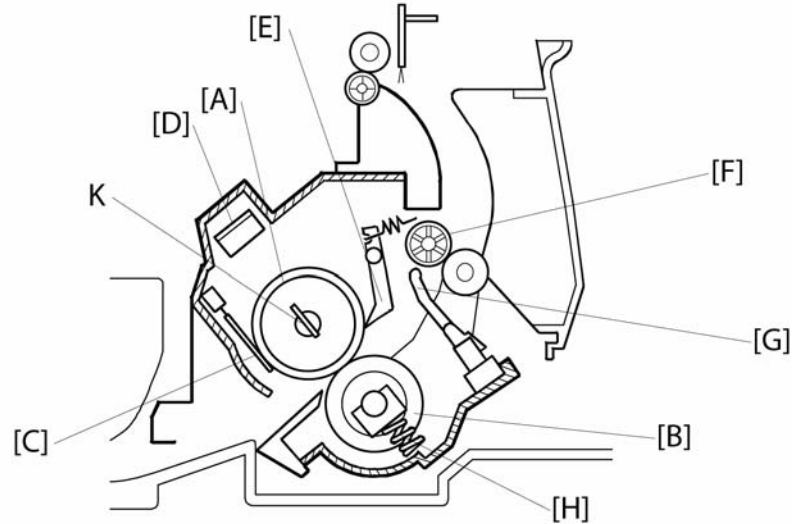

**Figure 11**

The laser unit [A] has the tray empty sensor [B] built into it. The tray empty sensor detects the presence or absence of paper. The sensor has an actuator that extends through a slot in the paper tray bottom plate [C], so that the sensor is actuated when paper is placed in the upper tray. When the upper tray runs out of paper, the actuator of the tray empty sensor moves into the slot in the upper tray bottom plate. This informs the CPU that paper has run out.

## Fusing

### Overview



**Figure 1**

After the image is transferred, the sheet enters the fusing unit. The image is fused to the sheet by applying heat and pressure through the use of a heat roller [A] and pressure roller [B].

The CPU monitors the heat roller temperature through a thermistor [C] that is in contact with the heat roller surface. A thermostat [D] protects the fusing unit from overheating.

The heat roller stripper fingers [E] separate the sheet from the heat roller and direct it to the exit rollers [F]. The paper feed/exit sensor [G], which is under the fusing unit, monitors the progress of the sheet through the fusing unit and detects misfeeds. The exit rollers [F] drive the sheet to the paper output tray.

Springs [H] at the front and rear apply the proper fusing pressure between the heat roller and pressure roller.

The fusing lamp [K] is located in the heat roller.

### Power Save Control

When the main switch is turned on, the machine turns on the fusing lamp. For printing, the machine raises the fusing temperature to 175°C. The fusing temperature is kept at 175°C during printing.

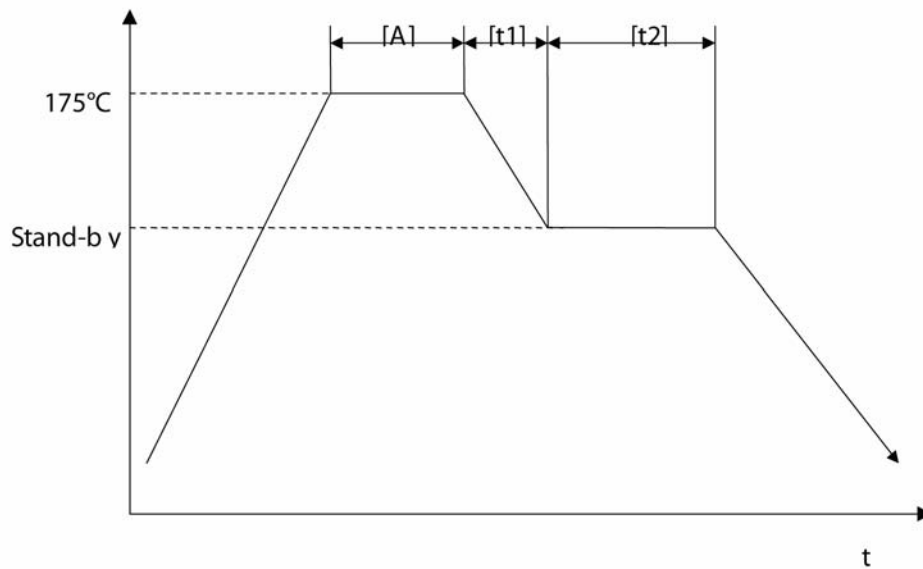

**Figure 2**

When the power saver timer expires, the machine automatically goes into energy saver mode.

**Power saver timer**

t1 =? minutes.

- After time interval t1 passes following printing, copying, scanning, or key-in [A], the LCD and all LEDs go off.

t1 + t2 =? minutes or? minutes (selectable)

- The default value is? minutes. (Economy Mode)
- Pressing the Clear Modes key for more than one second will change this condition.
- When the Economy Mode LED is lit, t1 + t2 =? minutes.
- When the Economy Mode LED is not lit, t1 + t2 =? minutes.

## Cover Interlock Switch



**Figure 3**

When the front door is opened, the interlock switch will be opened and power supply to the following parts will be cut.

- Power pack
- Laser diode driver
- Fan motor
- Main motor
- Polygon mirror motor
- Fusing lamp

## Paper Feed Drive Release and Fusing Drive Release

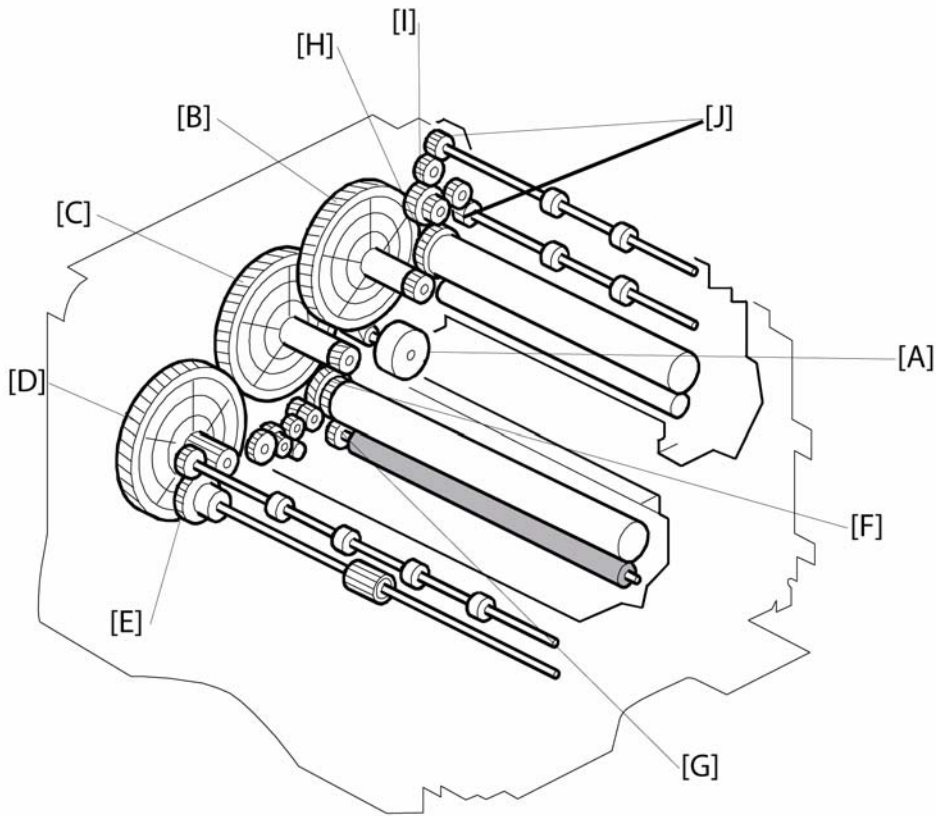
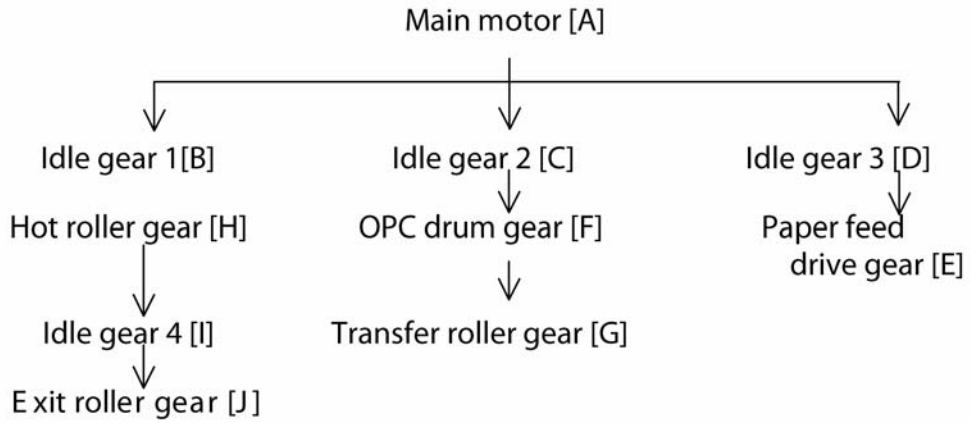

Figure 1



The main motor drives the paper feed unit, the transfer roller, the toner cassette, and fusing unit through a series of gears as follows.



## GP 19 Service Log

### Service Log

Use the service log to record all service procedures. The service log is included at the end of the manual.

## 7 Wiring Data

WD1 Connector Information ..... [7-3](#)

This page is intentionally blank

## WD1 Connector Information



**Figure 1 Overview of the position of the connectors and sockets for the control panel PWB (bottom view):**

**Table 1: List of connectors:**

Connector	Topography	Number of points	Gender	Position
CPU Connection	P4200	16	Female	Elbow top contact
LCD	P4002	10	Female	Elbow, top contact
Smart card	P4001	10	Female	

**Table 2: CPU - P4200: CPU connection**

Pin	Signal	Input/Output	Utilization
1-7-8-10-15	GND	-	Ground
2	FERCAP	I	Detection of smart card
3	CVCC	I/O	Smart card power supply (3.3V) (controlled by I/O CVCC)
4	CLKPUCE	O	Smart card clock
5	RSTPUCE	I	Smart card reset
6	IOPUCE	I/O	Smart card data
9	SCLKPUP	O	Serial clock link for differential registers
11	RXPUP	I	Sending data from the front panel
12	TXPUP	O	Sending data from the CPU
13	STROB1	-	Out-of-register strobe to control the keyboard

**Table 2: CPU - P4200: CPU connection**

14	STROB2	-	Out-of-register strobe to control the display
16	P5V	-	5V power supply

**Table 3: LCD - P4002: LCD interface**

Pin	Signal	Input/Output	Utilization
1	GND	-	Ground
2	V0	O	LCD Contrast
3	RS	O	Selection of registers
4	R/W	O	Read or Write (driver configured to write in 0V)
5	LCD_E	O	Enable Signal (active at 1)
6	VCCLCD	-	Vcc: 4.5V to 5.5V
7	DB4	O	Data (Bit 4)
8	DB5	O	Data (Bit 5)
9	DB6	O	Data (Bit 6)
10	DB7	O	Data (Bit 7)

**Table 4: Smart card - P4001: connection with the smart card**

Pin	Signal	Input/Output	Utilization
1	CVCC	O	Smart card power supply (3.3V)
2	RSTPUCE	O	Smart card reset
3	CLKPUCE	O	Smart card clock
4	-	-	Not connected
5	GND	-	Ground
6	-	-	Not connected
7	IOPUCE	I/O	Smart card data (input/output)
8	-	-	Not connected
S1	GND	-	Ground
S2	FERCAP	I	Smart card detection

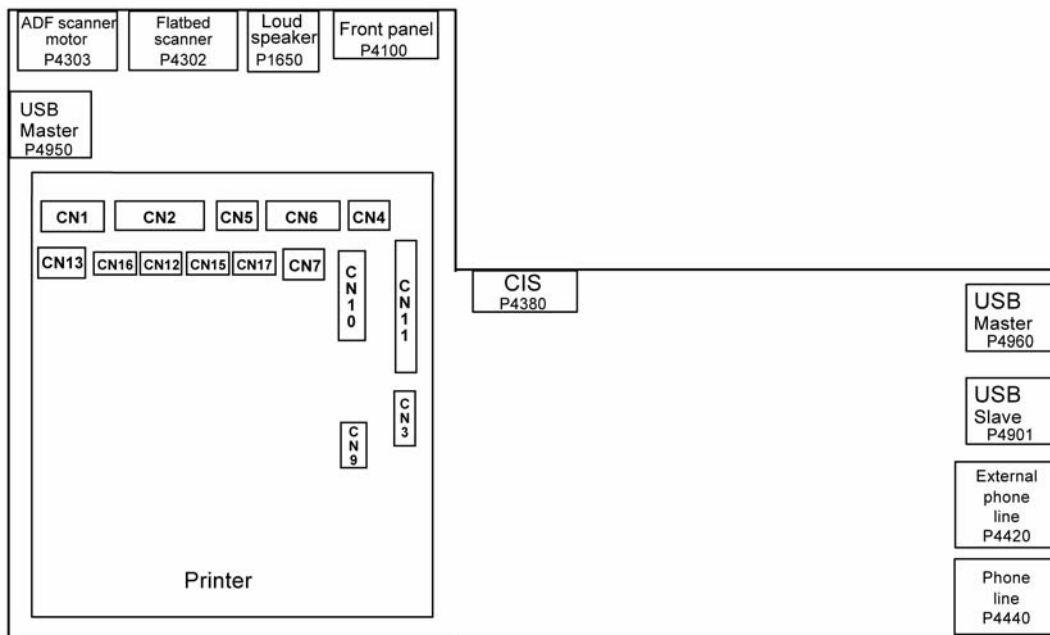

**Figure 5 Overview of the CPU card connector positions (3100MFP/X)**

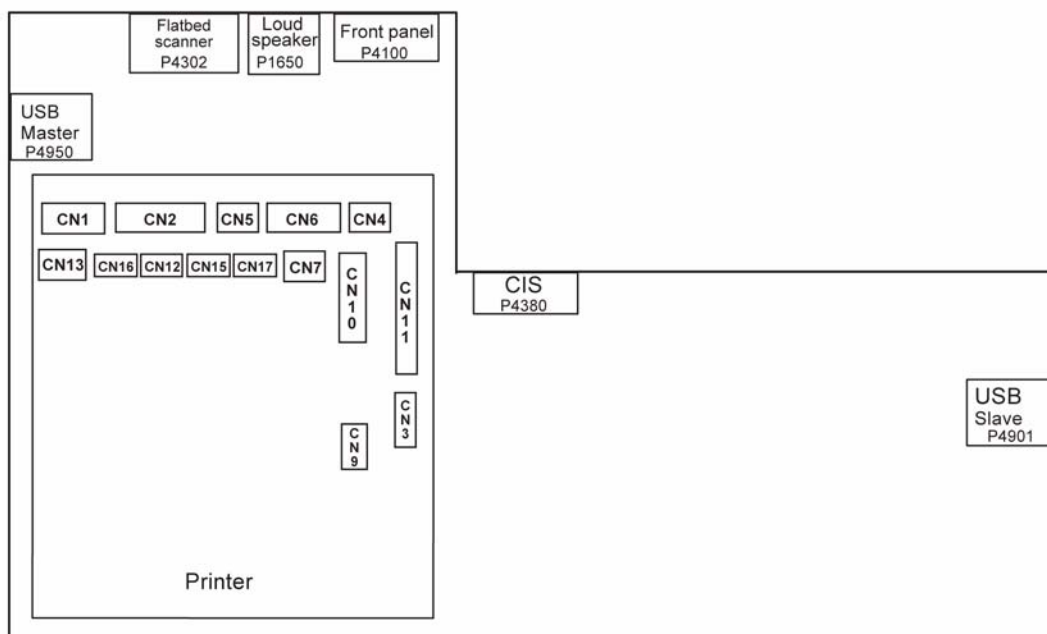

**Figure 6 Overview of the CPU card connector positions (3100MFP/S)**

Table 7: List of connectors:

Connector	Topography	Number of points	Sex	Position
Printer	CNx			
Loudspeaker	P1650	2		
Front panel	P4100	16	Female	Straight, top contact
ADF scanner motor	P4303	11	Female	Straight
Flatbed scanner motor	P4302	5	Female	Straight
CIS	P4380	12	Female	Straight, top contact
Phone line	P4420	4	Female	
External phone line	P4440	4	Female	
USB Slave	P4901	4	External, type USB type B	
USB Master	P4950	4	External, type USB type A	
USB Master	P4960	4	External, type USB type A	

Table 8: CNx: printer connectors

Topography	Connector	Pin	Signal	Input/Output	Utilization
CN1	Polygon motor				
		1	+24VS	-	24V power supply
		2	GND	-	Ground
		3	XPMENA	S	Starting the polygon motor
		4	XSCRDY	E	Locking the polygon motor
		5	PMCLK		Polygon motor clock
CN2	Diode laser				
		1	+5VLD	-	
		2	XLDNA	O	Activating the laser
		3	APCSH	O	Sampling
		4	XDETP	I	Ray beam detector
		5	GND	-	Ground
		6	XVD	O	Diode laser video
		7	NC	-	Not connected
CN3	Printer motor				
		1	P24VS	-	24V power supply



Table 8: CNx: printer connectors

		2	GND	-	Ground
		3	P5V	-	
		4	XMMENA		
		5	MMCLK		
		6	MMCW		
		7	XMMLOCK		
		8	MMGAIN		
CN4	Fan				
		1	FANEMA	O	Fan in operation motor signal
		2	GND	-	Ground
		3	FANLOCK		
CN5	Paper output clutch				
		1	+24VS	-	24V power supply
		2	XFPCL	O	Electric paper clutch signal
CN6	Paper detection captors				
		1-4-7	GND	-	Ground
		2	XFEED	I	Paper feed signal captor
		3-6-9	+5V	-	5V power supply
		5	XREGIST	I	Register of signal captors
		8	XMANUAL	I	Manual paper feed signal captor
CN7	Paper output captor				
		1	GND	-	Ground
		2	XEXIT	I	Four paper output signal captors
		3	+5V	-	5V power supply
CN9	Debug				
		1	+5V	-	5V power supply
		2	DBGRXD	I	Debug receipt
		3	DBGTXD	O	Debug command
		4	GND	-	Ground
CN10	High voltage				
		1	TRAPWM0	O	PWM signal for transfer of charger (+)
		2	TRAPWM1	O	PWM signal for transfer of charger (-)
		3	BIASPWM	O	PWM development signal
		4	CHEPWM	O	PWM signal charger
CN11	Power supply				
		1	HTON	O	Phase Fuser control
		2	ZEROC	I	Control signal

**Table 8: CNx: printer connectors**

		3	HTEN	O	Fuser relay (Activated to H)
		4	GND	-	Ground
		5-1213	+24V	-	24V power supply
		6-710-11	GND	-	Ground
		8-9	+5V	-	5V power supply
CN12	Temperature captor	1	FTEMP	I	Fuser temperature detector
		2	GND	-	Ground
CN13	Opening of printer cover captor				
		1	P24V	I	24V power supply
		2	P24VS	O	24V power supply
CN15	IAO captor (presence of toner)				
		1	XAIO	I	Detection of cartridge
		2	GND	-	Ground
CN16	Motor temperature captor				
		1	TEMP	I	Detection of printer motor temperature
CN17	Printer LED bar power supply				
		2	GND	-	Ground
		1	XLED	O	Printer LED bar command
		2	P24VS	O	24V power supply

**Table 9: Loudspeaker - P1650: connection with the loudspeaker**

Pin	Signal	Input/Output	Utilization
1	HPP	O	Differentiated BF signal to HP
2	HPN	O	Differentiated BF signal to HP

**Table 10: Frontpanel - P4100: connection with the front panel card**

Pin	Signal	Input/Output	Utilization
1	P5V	-	5V power supply
2-7-9-10-16	GND	-	Ground
3	STRB2	-	Out-of-register strobe to control the display
4	STRB1	-	Out-of-register strobe to control the keyboard
5	TXPUP	O	Data emitted by the CPU
6	RXPUP	I	Data emitted by the front panel
8	SCLKPUP	O	Serial link clock for differentiated registers
11	IOPUCE	I/O	Smart card data (3.3V)
12	RSTPUCE	O	Smart card reset

**Table 10: Frontpanel - P4100: connection with the front panel card**

13	CLKPUCE	O	Smart card clock
14	CVCC	O	Smart card power supply (3.3V) (controlled by I/O CVCC)
15	FERCAP	I	Detection of smart card

**Table 11: ADF scanner motor - P4303: connection with the ADF scanner motor**

Pin	Signal	Input/Output	Utilization
1	P24V	-	24V power supply
2	ADF_BN	O	Scanner motor coil BN
3	ADF_B	O	Scanner motor coil B
4	ADF_AN	O	Scanner motor coil AN
5	ADF_A	O	Scanner motor coil A
6	GND	-	Ground
7	PSF	I	Sheet sensor
8	ALIMPSF	-	PSF sensor power supply
9	GND	-	Ground
10	STSC	I	Document ready sensor
11	ALIMOUVCAP	I	STSC sensor power supply

**Table 12: Flatbed scanner motor - P4302: connection with the flatbed scanner motor**

Pin	Signal	Input/Output	Utilization
1	P24V	-	24V power supply
2	FTB_BN	O	Scanner motor coil BN
3	FTB_B	O	Scanner motor coil B
4	FTB_AN	O	Scanner motor coil AN
5	FTB_A	O	Scanner motor coil A

**Table 13: Phone line - P4420**

Pin	Signal	Input/Output	Utilization
1	R1	-	Loopback
2	L1	-	Phone line
3	L2	-	Phone line
4	R2	-	Loopback

**Table 14: External phone line - P4440**

Pin	Signal	Input/Output	Utilization
1	NC	-	
2	L1	-	Phone line
3	L2	-	Phone line
4	NC	-	

**Table 15: CIS - P4380: connection with the CIS**

Pin	Signal	Input/Output	Utilization
1	VIDCIS	I	CIS video
2	CMD RESOL	O	300/600dpi resolution command
3	VREFCIS	O	CIS voltage reference
4	VIDEOGND	-	Ground
5	CLKCIS	O	CIS (synchro point) pixel clock
6	ALIMCIS	-	3.3V power supply
7	SPCIS	O	Start Pulse CIS (line synchro)
8	ALIMLED	O	leds power supply (in voltage)
9	GNDLEDB	O	Blue led cathode
10	GNDLEDV	O	Green led cathode
11	GNDLEDR	O	Red led cathode
12	GND	-	Ground

**Table 16: USB - P4901: USB slave interface**

Pin	Signal	Input/Output	Utilization
1	VBUS_USB	I	Power supply provided by the master
2	USBN	I/O	Differential pair
3	USBP	I/O	Differential pair
4	GND	I/O	Ground

**Table 17: USB - P4950: USB master interface**

Pin	Signal	Input/Output	Utilization
1	VBUS_USB_HO ST1	O	Power supply provided to the slave
2	USBN	I/O	Differential pair
3	USBP	I/O	Differential pair
4	GND	I/O	Ground

**Table 18: USB - P4960: USB master interface**

Pin	Signal	Input/Output	Utilization
1	VBUS_USB_HO ST2	O	Power supply provided to the slave
2	USBN	I/O	Differential pair
3	USBP	I/O	Differential pair
4	GND	I/O	Ground

This page is intentionally blank

XEROX			ADF	OPTICS	FUSER	XERO	PAPER FEED	MISC	
Serial Number	Account Data	Key Op							
Date	Meter	CSE							
1	Problem	Subsystem	Inc	PLEASE PRINT					Adjusted Tag
2	Problem	Subsystem	Inc						
3	Problem	Subsystem	Inc						
4	Problem	Subsystem	Inc						
5	Problem	Subsystem	Inc						

**CONFIDENTIAL**  
(when filled in)

## EHS 700 - Health & Safety Incident Report Form for Incidents Involving a Xerox Product

For incidents in Canada: PIPEDA consent given <input checked="" type="checkbox"/> YES <input type="checkbox"/> NO	<b>EH&amp;S Office Use ONLY</b> EH&S Incident Reference Number:
PIPEDA is the Canadian "Personal Information Protection and Electronic Documents Act."	

<b>*Date Of Incident</b> (mm / dd / yy):	
<b>Product Description</b>	
<b>*Model No. or Product Name:</b>	
<b>Product Serial Number:</b>	<b>Serial Number(s) of Accessory (ies):</b>
<b>Installation Date:</b>	<b>Total Copy Meter:</b>
<b>Date of last service maintenance:</b>	
<b>List damaged and affected part(s) of the machine by description and part number:</b>	
<div style="text-align: center;"><u><b>*Description</b></u></div>	<div style="text-align: center;"><u><b>Part Number</b></u></div>
<b>*Location of product and affected part(s):</b>	
<b>Customer Identification</b>	
<b>*Customer Name:</b>	<b>*Name of Customer Contact Person:</b>
<b>*Address:</b>	<b>E-mail:</b>
	<b>*Telephone:</b>
	<b>Fax:</b>
<b>Customer Service Engineer Identification</b>	
<b>*Name</b> (required for Xerox serviced equipment):	<b>Employee:</b>
	<b>E-mail:</b>
<b>Location:</b>	<b>*Phone</b> (required for Xerox serviced equipment):
<b>Individual Providing Notification</b>	
<b>*Name:</b>	<b>*Title:</b>
<b>*Organization:</b>	<b>*Telephone Number:</b>
	<b>E-Mail:</b>
<b>Mailing Address:</b>	<b>*Date Report Submitted:</b>

\* Required information is preceded by asterisk, **title shown in red**, turquoise wash background



**Details of Incident**

**\*Description Of Incident: (Check all that apply)**

Smoke

**Describe quantity and duration of smoke:**

Fire with open flames seen

Electric shock to operator or service representative

Physical injury/illness to operator or service representative

**Describe:**

Other, **Describe:**

**MANDATORY DESCRIPTION** (above): Provide a detailed description of all valid factors that may have contributed to the incident. Hardware involved in the incident should be preserved and retained for further investigation should investigation be deemed necessary by EH&S.

LIST INCIDENT DESCRIPTIONS AND SUPPORT DIAGRAMS/DATA INCLUDED OR ATTACHED:

**\*Any damage to customer property?** No  Yes  Describe:

**\*Did external emergency response provider(s) such as fire department, ambulance, etc. respond?**

No  Yes  Identify: (i.e., source, names of individuals)

**Apparent cause of incident (identify part that is suspect to be responsible for the incident)**

**\*Preliminary actions taken to mitigate incident:**

**Instructions:** E-mail or fax both pages of this completed form to EH&S:

- For incidents in **Xerox Europe** and **Developing Markets East**  
(Middle East, Africa, India, China, and Hong Kong)  
Submit to Elaine Grange  
**e-mail:** [ehs-europe@xerox.com](mailto:ehs-europe@xerox.com) or **fax:** +44 (0) 1707 35 3914 [Intelnet 8\*668 3914]
- For incidents in **North America** and **Developing Markets West**  
(Brazil, Mexico, Latin America North and Latin America South,  
Submit form to Doris Bush  
**e-mail:** [usa.xerox.ehs@xerox.com](mailto:usa.xerox.ehs@xerox.com) or fax 888-845-0908 [1-585-422-7918 / Intelnet 8\*222-7734]

\* Required information is preceded by asterisk, **title shown in red**, turquoise wash background

**PUBLICATION COMMENT SHEET**

Please copy this master sheet and use it to help us to improve this publication. We would like you to tell us about improvements to its accuracy, format and quality.

Please give specific references, i.e.: page numbers and figure numbers and attach marked up photocopies whenever possible. If you have identified a solution please include your suggestions with your reply.

Please also answer the customer satisfaction question set.

When you have completed the PCS, send it by internal mail to the address below. You will receive an acknowledgement and feedback on your comments. Please ensure that your name and CBU/District location code are fully completed.

NAME:		OPERATING COMPANY:	
JOB TITLE:			
ENGINEER NUMBER:		CBU/DISTRICT LOCATION CODE:	
CONTACT TELEPHONE NUMBER:			
DATE:			
PRODUCT AND PUBLICATION TITLE:		PUBLICATION REVISION DATE:	SOFTWARE REVISION LEVEL:
PAGE NUMBER:		<p align="center"><b>COMMENT</b></p> <p align="center">Please submit a marked-up photocopy of the relevant pages</p>	

**CUSTOMER SATISFACTION QUESTION SET**

QUESTION	NOT APPLICABLE	VERY SATISFIED	SATISFIED	NEITHER SATISFIED NOR DISSATISFIED	DISSATISFIED	VERY DISSATISFIED
DO YOU FIND THE MANUAL IS TECHNICALLY ACCURATE?						
DO YOU FIND THE FORMAT OF THE MANUAL EASY TO USE?						
WHAT IS YOUR OVERALL SATISFACTION LEVEL WITH THE MANUAL						

<b>FOR OFFICE USE ONLY</b>	Global Knowledge & Language Services Xerox Europe Enterprise Centre Bessemer Road Welwyn Garden City Hertfordshire AL7 1HE England Attention: Phil Hayes
RECEIVED DATE:	
PCS. NUMBER:	
MANAGER:	
DUE DATE:	

