

XEROX®

Service Manual

701P46430

Phaser® 6250

Color Laser Printer



Phaser® 6250

Color Laser Printer

Warning

The following servicing instructions are for use by qualified service personnel only. To avoid personal injury, do not perform any servicing other than that contained in the operating instructions, unless you are qualified to do so.

Revised: January, 2007



Copyright © 2003, 2007 Xerox Corporation. All Rights Reserved. Unpublished rights reserved under the copyright laws of the United States. Contents of this publication may not be reproduced in any form without permission of Xerox Corporation.

Copyright protection claimed includes all forms of matters of copyrightable materials and information now allowed by statutory or judicial law or hereinafter granted, including without limitation, material generated from the software programs which are displayed on the screen such as styles, templates, icons, screen displays, looks, etc.

Xerox technical training materials and service manuals are intended for use by authorized Xerox service technicians and service partners only and are not for resale. These materials may not be distributed, copied or otherwise reproduced without prior written consent from Xerox Corporation.

XEROX®, The Document Company®, the digital X®, CentreWare®, infoSMART®, Made For Each Other®, PagePack™, Phaser®, PhaserSMART®, and Walk-Up™ are trademarks of Xerox Corporation in the United States and/or other countries.

Acrobat®, Adobe® Reader®, Adobe Type Manager®, ATM™, Illustrator®, PageMaker®, Photoshop®, PostScript®, Adobe Brilliant® Screens, Adobe Garamond®, Adobe Jenson™, Birch®, Carta®, IntelliSelect®, Mythos®, Quake®, and Tekton® are trademarks of Adobe Systems Incorporated in the United States and/or other countries.

Apple®, AppleTalk®, Bonjour®, EtherTalk®, LaserWriter®, LocalTalk®, Macintosh®, Mac OS®, TrueType®, Apple Chancery®, Chicago®, Geneva®, Monaco®, New York®, and QuickDraw® are trademarks of Apple Computer, Inc. in the United States and/or other countries.

HP-GL®, HP-UX®, and PCL® are trademarks of Hewlett-Packard Corporation in the United States and/or other countries.

IBM® and AIX® are trademarks of International Business Machines Corporation in the United States and/or other countries.

Windows®, Vista™, Windows Server™, and Wingdings® are trademarks of Microsoft Corporation in the United States and/or other countries.

Novell®, NetWare®, NDPS®, NDS®, Novell Directory Services®, IPX™, and Novell Distributed Print Services™ are trademarks of Novell, Incorporated in the United States and/or other countries.

SunSM, Sun Microsystems™, and Solaris™ are trademarks of Sun Microsystems, Incorporated in the United States and/or other countries.

SWOP® is a trademark of SWOP, Inc.

UNIX® is a trademark in the United States and other countries, licensed exclusively through X/Open Company Limited.

This product uses code for SHA-1 written by John Halleck, which is being used with his permission.

This product includes an implementation of LZW licensed under U.S. Patent 4,558,302.

Other marks are trademarks or registered trademarks of the companies with which they are associated.

PANTONE® Colors generated may not match PANTONE-identified standards. Consult current PANTONE Publications for accurate color. PANTONE® and other Pantone, Inc. trademarks are the property of Pantone, Inc. © Pantone, Inc., 2000.

As an Energy Star® partner, Xerox Corporation has determined that this product meets the Energy Star guidelines for energy efficiency. The Energy Star name and logo are registered U.S. marks.



Service Terms

Manual Terms

Various terms are used throughout this manual to either provide additional information on a specific topic or to warn of possible danger present during a procedure or action. Be aware of all symbols and terms when they are used, and always read NOTE, CAUTION, and WARNING statements.

Common Acronyms:

The following list defines the acronyms that may be found in this manual.

ADC: Automatic Density Control	MCU: Engine Control Board
BTR: Bias Transfer Roller	NCS: Non-Contact Sensor
CRUM: Customer Replaceable Unit Monitor	PHD: Imaging Unit
CTD: Toner Density Control	PL: Corresponds to the FRU Parts List.
DRV: Motor Driver Board	RMI: Routine Maintenance Item
ESD: Electrostatic Discharge	ROS: Laser Scanning Unit
IDT: Intermediate Transfer Unit	RTC: Charge Roller

Note

A note indicates an operating or maintenance procedure, practice or condition that is necessary to efficiently accomplish a task.

A note can provide additional information related to a specific subject or add a comment on the results achieved through a previous action.

Caution

A caution indicates an operating or maintenance procedure, practice or condition that, if not strictly observed, results in damage to, or destruction of, equipment.

Warning

A warning indicates an operating or maintenance procedure, practice or condition that, if not strictly observed, results in injury or loss of life.

Product Terms

Caution: A personal injury hazard exists that may not be apparent. For example, a panel may cover the hazardous area.

Danger: A personal injury hazard exists in the area where you see the sign.

Symbols Marked on the Product



DANGER high voltage.



Protective ground (earth) symbol.



Hot surface on or in the printer. Use caution to avoid personal injury.



The surface is hot while the printer is running. After turning off the power, wait 30 minutes.



Avoid pinching fingers in the printer. Use caution to avoid personal injury.



Use caution (or draws attention to a particular component). Refer to the manual(s) for information.

Power Safety Precautions

Power Source

For 110 VAC printers, do not apply more than 140 volts RMS between the supply conductors or between either supply conductor and ground. Use only the specified power cord and connector. For 220 VAC printers, do not apply more than 264 volts RMS between the supply conductors or between either supply conductor and ground. Use only the specified power cord. This manual assumes that the reader is a qualified service technician.

Plug the three-wire power cord (with grounding prong) into a grounded AC outlet only. If necessary, contact a licensed electrician to install a properly grounded outlet. If the product loses its ground connection, contact with conductive parts may cause an electrical shock.

Disconnecting Power

Turning the power off using the On/Off switch does not completely de-energize the printer. You must also disconnect the printer power cord from the AC outlet. Position the power cord so that it is easily accessible during servicing so that you may power down the printer during an emergency. Disconnect the power plug by pulling the plug, not the cord.

Disconnect the power cord in the following cases:

- if the power cord or plug is frayed or otherwise damaged,
- if any liquid or foreign material is spilled into the case,
- if the printer is exposed to any excess moisture,
- if the printer is dropped or damaged,
- if you suspect that the product needs servicing or repair,
- whenever you clean the product.

Electrostatic Discharge (ESD) Precautions

Some semiconductor components, and the respective sub-assemblies that contain them, are vulnerable to damage by Electrostatic discharge (ESD). These components include Integrated Circuits (ICs), Large-Scale Integrated circuits (LSIs), field-effect transistors and other semiconductor chip components. The following techniques will reduce the occurrence of component damage caused by static electricity.

Be sure the power is off to the chassis or circuit board, and observe all other safety precautions.

- Immediately before handling any semiconductor components assemblies, drain the electrostatic charge from your body. This can be accomplished by touching an earth ground source or by wearing a wrist strap device connected to an earth ground source. Wearing a wrist strap will also prevent accumulation of additional bodily static charges. Be sure to remove the wrist strap before applying power to the unit under test to avoid potential shock.
- After removing a static sensitive assembly from its anti-static bag, place it on a grounded conductive surface. If the anti-static bag is conductive, you may ground the bag and use it as a conductive surface.
- Do not use freon-propelled chemicals. These can generate electrical charges sufficient to damage some devices.
- Do not remove a replacement component or electrical sub-assembly from its protective package until you are ready to install it.
- Immediately before removing the protective material from the leads of a replacement device, touch the protective material to the chassis or circuit assembly into which the device will be installed.
- Minimize body motions when handling unpackaged replacement devices. Motion such as your clothes brushing together, or lifting a foot from a carpeted floor can generate enough static electricity to damage an electro-statically sensitive device
- Handle IC's and EPROM's carefully to avoid bending pins.
- Pay attention to the direction of parts when mounting or inserting them on Printed Circuit Boards (PCB's).

Service Safety Summary

General Guidelines

For qualified service personnel only: Refer also to the preceding Power Safety Precautions.

Avoid servicing alone: Do not perform internal service or adjustment of this product unless another person capable of rendering first aid or resuscitation is present.

Use care when servicing with power: Dangerous voltages may exist at several points in this product. To avoid personal injury, do not touch exposed connections and components while power is on. Disconnect power before removing the power supply shield or replacing components.

Do not wear jewelry: Remove jewelry prior to servicing. Rings, necklaces and other metallic objects could come into contact with dangerous voltages and currents.

Power source: This product is intended to operate from a power source that will not apply more than 264 volts rms for a 220 volt AC outlet or 140 volts rms for a 110 volt AC outlet between the supply conductors or between either supply conductor and ground. A protective ground connection by way of the grounding conductor in the power cord is essential for safe operation.

Warning Labels

Read and obey all posted warning labels. Throughout the printer, warning labels are displayed on potentially dangerous components. As you service the printer, check to make certain that all warning labels remain in place.

Safety Interlocks

Make sure all covers and the printer's front panel are in place and all interlock switches are functioning correctly after you have completed a printer service call. If you bypass an interlock switch during a service call, use extreme caution when working on or around the printer.

CLASS 1 LASER PRODUCT

The Phaser® 6250 Color Laser Printer is certified to comply with Laser Product Performance Standards set by the U.S. Department of Health and Human Services as a Class 1 Laser Product. This means that this is a class of laser product that does not emit hazardous laser radiation; this is possible only because the laser beam is totally enclosed during all modes of customer operation. When servicing the printer or laser unit, follow the procedures specified in this manual and there will be no hazards from the laser.

Servicing Electrical Components

Before starting any service procedure, switch off the printer power and unplug the power cord from the wall outlet. If you must service the printer with power applied, be aware of the potential for electrical shock.

Warning

Turning the power off by using the On/Off switch does not completely de-energize the printer. You must also disconnect the printer power cord from the AC outlet. Position the power cord so that it is easily accessible during servicing.

Warning

Do not touch any electrical component unless you are instructed to do so by a service procedure.



Servicing Mechanical Components

When servicing mechanical components within the printer, manually rotate drive assemblies, rollers, and gears.

Warning

Do not try to manually rotate or manually stop the drive assemblies while any printer motor is running.

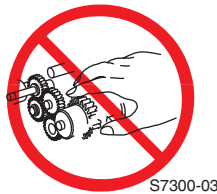

Servicing Fuser Components

Warning

This printer uses heat to fuse the toner image to media. The Fuser Assembly is VERY HOT. Turn the printer power off and wait at least 5 minutes for the Fuser to cool before you attempt to service the Fuser Assembly or adjacent components.

Regulatory Specifications

Federal Communications Compliance

The equipment described in this manual generates and uses radio frequency energy. If it is not installed properly in strict accordance with Xerox instructions, it may cause interference with radio and television reception or may not function properly due to interference from another device. However, there is no guarantee that interference will not occur in a particular installation. If this equipment does cause harmful interference to radio or television reception, which can be determined by turning the equipment off and on, the user is encouraged to try to correct the interference by one or more of the following measures:

- Reorient or relocate the receiver (device being interfered with).
- Increase the separation between the printer and the receiver.
- Connect the printer into an outlet on a circuit different from that which the receiver is connected.
- Route the interface cables on the printer away from the receiver
- Consult the dealer, Xerox service, or an experienced radio/television technician for help.

Changes or modifications not expressly approved by Xerox can affect the emission and immunity compliance and could void the user's authority to operate this product. To ensure compliance, use shielded interface cables. A shielded parallel cable can be purchased directly from Xerox at www.xerox.com/office/6250supplies.

Xerox has tested this product to internationally accepted electromagnetic emission and immunity standards. These standards are designed to mitigate interference caused or received by this product in a normal office environment. This product is also suitable for use in a residential environment based on the levels tested.

In the United States this product complies with the requirements of an unintentional radiator in part 15 of the FCC rules. Operation is subject to the following two conditions: (1) this device may not cause harmful interference; (2) this device must accept any interference received, including interference that may cause undesired operation.

This digital apparatus does not exceed the Class B limits for radio noise emissions from digital apparatus set out in the Radio Interference Regulations of the Canadian Department of Communications, ICES-003.

Le présent appareil numérique n'émet pas de bruits radioélectrique dépassant les limites applicables aux appareils numériques de la classe B prescrites dans le Règlement sur le brouillage radioélectrique édicté par le ministère des Communications du Canada, NMB-003.

Declaration of Conformity

Xerox Corporation, declares, under our sole responsibility that the printer to which this declaration relates, is in conformity with the following standards and other normative documents:

In the European Union

following the provisions of the Low Voltage Directive 73/23/EEC and its amendments:

EN 60950 (IEC 950)	"Safety of Information Technology Equipment including Electrical Business Equipment"
-----------------------	--

following the provisions of the Electromagnetic Compatibility Directive 89/336/EEC and its amendments:

EN55022:1998 (CISPR 22)	"Limits and Methods of measurement of radio interference characteristics of Information Technology Equipment." Class B.
EN61000-3-2:1995 +A1:1998+A2:1998 (IEC61000-3-2)	"Part 3: Limits - Section 2: Limits for harmonic current emissions (equipment input current less than or equal to 16A per phase)."
EN61000-3-3:1995 (IEC61000-3-3)	"Part 3: Limits - Section 3: Limitation of voltage fluctuations and flicker in low-voltage supply systems for equipment with rated current less than or equal to 16A."
EN55024:1998 (CISPR 24)	"Information technology equipment - Immunity characteristics - Limits and methods of measurement. "

CISPR 24 Immunity Phenomena	Basic Standard	Test Specification
Electrostatic Discharge	IEC61000-4-2:1995	6kV Contact, 10kV Air
Radio-Frequency Electromagnetic Field (radiated)	IEC61000-4-3:1995	80-1000 MHz, 3V/m, 80% AM @ 1KHz
Fast Burst Transients	IEC61000-4-4:1995	5/50 Tr/Th ns, 5kHz Rep. Freq 0.5kV on Signal Lines 1kV on AC Mains
Line Surge	IEC61000-4-5:1995	Combination wave 2.0kV Common mode 2.0kV Differential mode
Radio-Frequency Electromagnetic Field (Conducted)	IEC61000-4-6:1996	0.15 - 80 MHz, 3V, 80% AM @ 1kHz
Line voltage dips	IEC61000-4-11:1994	>95% dip for ½ cycle @ 50 Hz 30% dip for 25 cycles @ 50 Hz

**CISPR 24 Immunity
Phenomena****Basic Standard****Test Specification**

Line voltage drop-out

IEC61000-4-11:1994

>95% dropout for 250 cycles @ 50 Hz

This product, if used properly in accordance with the user's instructions is neither dangerous for the consumer nor for the environment. A signed copy of the Declaration of Conformity for this product can be obtained from Xerox.

Contents

Service Terms	iv
Symbols Marked on the Product	v
Power Safety Precautions	vi
Electrostatic Discharge (ESD) Precautions	vii
Service Safety Summary	viii
Regulatory Specifications	x

1 General Information

Printer Introduction and Overview	1-2
Printer Configurations	1-2
Printer Memory and RAM Capabilities	1-4
Parts of the Printer	1-5
Exterior	1-5
Phaser 6250 Front Panel Configuration	1-6
Rear View	1-7
Image Processor Board	1-8
Routine Maintenance Items	1-9
Consumables	1-9
Consumable Life Counter Behavior	1-10
Printer Specifications	1-11
Physical Dimensions and Clearances	1-11
Functional Specifications	1-12
Electrical Specifications	1-13
Environmental Specifications	1-13
Media and Tray Specifications	1-14

2 Theory of Operation

Overview of the Phaser 6250 Color Laser Printer Theory of Operation	2-2
Summary of the Printing Process	2-2
Print Modes	2-5
Printer Controls	2-5
Paper Size Control	2-5
Selective Control; Paper Pick	2-6
Laser Light Intensity Control	2-6
Process Control	2-6
LED Light Density CTD (ADC) Control of Sensor	2-8
Color Registration Control	2-9
Transfer Roller Assembly Control	2-11
Toner Control	2-12
Fuser Control	2-13
Paper Path of the Printer	2-14
Paper Path Route	2-15

Major Assemblies and Functions	2-16
Frame and Drive Assemblies	2-16
Main Drive Assembly - Transmission Route	2-17
Gear Layout - Print Engine and Tray 1	2-18
Paper Tray 2	2-19
Paper Feed - Tray 2	2-20
HCF Drive and Gears - Transmission Route	2-25
500-Sheet Feeder Drive and Gears - Transmission Route	2-26
Retard Housing Assembly	2-27
Chute Assembly In	2-28
Chute Assembly Out	2-29
Chute Assembly Exit	2-30
Duplex Motor Drive and Gear - Transmission Route	2-31
Chute Assembly Registration (REG1)	2-32
Transfer Roller and Fuser Assembly	2-33
Fuser Drive Assembly - Transmission Route	2-34
Xerographics	2-35
Imaging Unit Charge Voltage Contacts	2-36
Toner Cartridge Assembly	2-38
Toner Cartridge Assembly - cont'd	2-39
Toner Motor Drive Assembly - Transmission Route	2-40
Developer Assembly Transmission Route	2-40

3 Error Messages and Codes

Introduction	3-2
Servicing Instructions	3-3
Using the Troubleshooting Procedures	3-4
General Notes on Troubleshooting	3-4
Voltage Measurements	3-5
Service Diagnostics	3-6
Service Diagnostic Front Panel Button Descriptions	3-7
Diagnostic Menu Map	3-8
Service Diagnostic Tests	3-9
Jam History Error Codes Table	3-16
Error Messages and Codes Summary Table	3-17
Jam Errors	3-19
Jam at Fuser: Jam F	3-19
Jam at Duplex: Jam D	3-21
Jam at Registration	3-23
Jam at Registration Roller: Jam RR	3-28
Misfeed at Tray 1 (MPT): Jam T1	3-30
Misfeed at Tray 2: Jam T2	3-33
Misfeed at Tray 3: Jam T3	3-36
Misfeed at Tray 4: Jam T4	3-39
Door and Cover Errors	3-41
Close Front Door	3-41

Consumable Errors	3-42
Install or Reseat Imaging Unit	3-42
Replace Imaging Unit or Imaging Unit is Near End of Life	3-43
Install or Reseat Transfer Roller	3-44
Replace Transfer Roller or Transfer Roller is at End of Life	3-45
Install or Reseat Fuser	3-46
Replace Fuser or Fuser is Near End of Life	3-47
Install or Lock [Y] [M] [C] [K] Toner Cartridge	3-48
Replace [Y] [M] [C] [K] Toner Cartridge or [Y] [M] [C] [K] Toner Is Low	3-50
Dusty Density Sensor	3-52
Output Tray is Full, Unload Paper	3-53
Remove Ribbon from [Y] [M] [C] [K] Toner Cartridge	3-54
Tray and Media Errors	3-55
Insert Tray [2] or Tray [2] Missing	3-55
Insert Tray [3] [4] or Tray [3] [4] Missing	3-57
Tray 2 Paper is Low	3-59
Tray [3] [4] Paper is Low	3-60
Out of Paper; Load Tray 1 (MPT) with [size] [type]	3-61
Out of Paper; Load Tray [2] [3] [4] with [size] [type]	3-62
Wrong Paper Size; Load Tray 2 with [size] [type]	3-63
Wrong Paper Size; Load Tray [3] [4] with [size] [type]	3-65
Wrong Paper Type; Load Tray [1 (MPT)] [2] [3] [4] with [size] [type] 3-67	
Fatal Errors	3-68
Laser Failure	3-68
Density Sensor Failure	3-69
Fuser Failure	3-70
Fuser Failure (cont'd)	3-71
Fuser Failure (cont'd)	3-72
Fuser Fan Failure	3-73
Rear Fan Failure	3-74
Generic Fan Failure	3-75
Engine Firmware Failure	3-76
Imaging Unit Firmware Failure	3-77
Fuser Firmware Failure	3-78
Controller to Engine Communications Failure	3-79
Engine NVRAM Error	3-80
Replace [Y] [M] [C] [K] Toner Cartridge	3-81
[Y] [M] [C] [K] Toner Cartridge Failure	3-82
Non-Phaser 6250 Fuser	3-83
Non-Phaser 6250 Imaging Unit	3-84
Environmental Sensor Failure	3-85

4 General Troubleshooting

Introduction	4-2
Printer Status Page	4-2
Power-Up Modes	4-2
System Start-Up and POST	4-3
System Boot Sequence	4-3
Power On Self Test (POST)	4-4
POST Faults	4-6
LED Blink Patterns	4-6
POST Diagnostic Test Descriptions	4-7
Front Panel Troubleshooting	4-8
No Front Panel Display after Power is Turned ON	4-8
Front Panel LED is on, Front Panel Display is Blank	4-8
Front Panel Continually Displays "Warming Up..."	4-8
Front Panel Continually Displays "Install or Reseat Imaging Unit"	4-8
Fault Isolation	4-9
Inoperable Printer Troubleshooting	4-9
Engine Power-Up Sequence	4-9
Printer Does Not Come to a "Ready" State	4-9
Printer Inoperable after Power Switch is On	4-10
Paper Size Switch Assembly	4-11
Power Supply	4-12
AC Power Supply Troubleshooting	4-13
DC Power Supply Troubleshooting	4-13
Media Jams and the Paper Path	4-15
Operating System and Application Problems	4-18
Macintosh printing problems	4-18
Windows printing problems	4-20
Network Problems	4-20

5 Print-Quality Troubleshooting

Print-Quality Problems Overview	5-2
Defects Associated with Specific Printer Components	5-3
Front Panel Test Prints	5-4
Test Print 1: CMYK Sample Page	5-4
Test Print 2: RGB Test Print	5-5
Service Test Prints	5-6
Test Print 3: Test Pattern Sample	5-6
600 x 600 Service Test Print	5-8
Print Engine Test Print	5-9
Print-Quality Troubleshooting	5-10
Light Prints	5-10
Light Print in Only One Color	5-11
Blank Prints	5-13
Black Prints with White Margin Border	5-14
Solid Dark or Dirty Prints, No Border	5-15

Missing Band, Voids Or Streaks In a Single Color or All Colors Parallel to the Leading Edge	5-16
Missing Band, Voids or Streaks in a Single Color or All Colors in Direction of Paper Travel	5-18
Repeating and/or Random Spots	5-19
Background Contamination	5-20
Residual Image, Ghosting or Hot Offset	5-22
Incomplete Fusing or Cold Offset	5-23
Mis-Registration, Color Layer not Correctly Registered in the Process Direction	5-24
Dirty Vertical Streaks on the Edges of the Page	5-25

6 Adjustments and Calibrations

Calibrations	6-2
Color Calibration	6-2
Margin Calibration	6-2
Adjustments	6-3
Horizontal and Vertical Color Registration	6-3
Resetting NVRAM	6-4
PostScript NVRAM Resets	6-4
Service Diagnostics PostScript NVRAM Resets	6-8

7 Cleaning and Maintenance

Service Preventive Maintenance Procedure	7-2
Cleaning	7-2

8 Service Parts Disassembly

Overview	8-2
Standard Orientation of the Printer	8-2
General Notes on Disassembly	8-3
Preparation	8-3
Notations in the Disassembly Text	8-3
Removing Routine Maintenance Items and Consumables	8-4
Transfer Roller Removal	8-4
Imaging Unit Removal	8-4
Fuser Removal	8-5
Toner Cartridge Removal	8-5
Print Engine Disassembly	8-6
Covers	8-6
Front Cover (PL 1.1.2)	8-6
Front Panel (PL 1.1.1)	8-7
Fuser Fan (PL 1.1.7)	8-8
Top Main Cover (PL1.1.9)	8-9
Image Unit Top Cover (Door C) (PL1.1.10)	8-10
Right and Left Side Covers (PL1.1.24), (PL1.1.30)	8-11

Rear Cover (PL 1.1.20)	8-12
Left and Right Links (PL 1.1.23)	8-13
Tray 1 (MPT) (PL1.1.99)	8-14
Front Right Cover (PL 1.1.25)	8-15
Front Left Cover Assembly (PL1.1.29)	8-16
Paper Feed	8-18
Paper Feed Roller (PL 2.1.2) (Routine Maintenance Item)	8-18
Turn Chute Assembly (PL3.1.2)	8-19
Printer Chassis/Feeder Assembly	8-20
Paper Pick Assembly (PL3.3.1)	8-22
Right and Left Housing (PL 3.2)	8-23
Temperature/Humidity Harness (PL3.2.1) and Sensor (PL3.2.2)	8-24
High-Capacity Feeder Harness (PL3.2.3)	8-25
Paper Size Switch Assembly (PL3.2.4)	8-26
Low Paper Lever (PL3.2.7), Indicator (PL3.2.8) and Indicator Guide (PL3.2.10)	8-27
Paper Pick Rollers (PL3.3.3)	8-29
No Paper Actuator (PL3.3.5), No/Low Paper Sensor (PL3.3.4)	8-30
Link Actuator (PL3.3.6)	8-32
Feed Solenoid (PL3.3.17)	8-33
Turn Clutch Assembly (PL3.3.18)	8-34
Roll Turn Assembly (PL3.3.20)	8-35
Paper Feed Roller (Routine Maintenance Item)	8-36
Retard Roller Housing Assembly (PL4.1.1)	8-37
Turn Roll (PL 4.1.2), Turn Clutch (PL 4.1.9), and Friction Clutch As- sembly (PL 4.1.4)	8-38
Retard Roller Assembly (PL4.1.5)	8-39
Chute Assembly In	8-41
Chute Assembly In (PL 5.1.1)	8-41
CTD (ADC) Sensor (PL 5.1.11)	8-42
Toner Full Sensor (PL 5.1.13)	8-43
Fuser Drive Assembly (PL 5.1.18)	8-44
Right Latch (Door A) (PL 5.1.21)	8-45
Left Latch (PL 5.1.30)	8-46
Chute Assembly Out	8-47
Chute Assembly Out (PL6.1.1)	8-47
Output Tray Full Actuator (PL 6.1.5) and Full Stack Sensor (PL 6.1.4) 8-50	
Duplex Actuator (PL 6.1.13) and Duplex Sensor (PL 6.1.4)	8-51
Tray 1 Actuator (PL 6.1.37) and Tray 1 Sensor (PL 6.1.4)	8-53
Static Eliminator Assembly (PL 6.1.9)	8-55
Duplex Roller (PL 6.1.12)	8-56
Latch Plate (PL 6.1.17), Latch Out (PL 6.1.18), Latch Holder (PL 6.1.19), and Latch Spring Out (PL 6.1.20)	8-57
Tray 1 Paper Pick Assembly (PL 6.1.27) (Roll Feed)	8-58
Tray 1 Feed Solenoid (PL 6.1.40)	8-59

Tray 1 Shaft (PL 6.1.28)	8-60
Tray 1 Bottom Plate (PL 6.1.42)	8-61
Chute Assembly Exit	8-62
Chute Assembly Exit (PL 7.1.1)	8-62
Exit Roller (PL 7.1.4)	8-63
Mid Roller (PL 7.1.5)	8-64
Duplex Motor Assembly (PL 7.1.8)	8-65
Exit Actuator (Fuser) (PL 8.1.7)	8-66
Strap (PL 8.1.13)	8-67
Xerographics	8-68
Laser Unit (PL 9.1.1)	8-68
Housing Assembly Bias (PL 9.1.4)	8-69
Chute Assembly Registration (PL 9.1.6) and Housing Assembly Electric (PL 9.1.11)	8-71
Registration Sensor Actuator (PL 9.1.9) and Registration Sensor (PL 9.1.8)	8-73
OHP Sensor and Harness (Kit) (PL 9.1.12)	8-75
Toner Cartridge Holder Assemblies	8-77
Toner Cartridge Holder Unit Assembly (PL 10.1)	8-77
Toner Cartridge Holder Assembly	8-80
Toner Present Switch Bracket and Actuator (PL 10.1.6 and 10.1.22)	8-82
Toner Low Sensor (PL 10.1.5)	8-84
CRUM Reader Box Assembly (PL 10.1.21)	8-85
EEPROM Board (PL 10.1.14)	8-86
Sub-High Voltage Power Supply Board (PL 10.1.15)	8-87
Frame and Drive Assemblies	8-88
Left Lever Plate (PL 11.1.1), Lever Bracket (PL 11.1.2), Lever Link (PL 11.1.3), Lever Drum (PL 11.1.4), and Lever Spring (PL 11.1.5)	8-88
Lever Plate Right (PL 11.1.7), Lever Bracket (PL 11.1.2), Lever Link (PL 11.1.6), Lever Drum (PL 11.1.4), and Lever Spring (PL 11.1.5)	8-91
Main Drive Assembly (PL 11.1.14)	8-94
Developer Drive Assembly (PL 11.1.13)	8-95
Actuator, I/L (PL 11.1.8) and Spring, I/L (PL 11.1.9)	8-96
Earth Ground Circuit Board (PL 11.1.16)	8-97
Electrical	8-98
AC Switch Harness Assembly (PL 12.1.11)	8-98
Low-Voltage Power Supply (PL 12.1.10)	8-99
Motor Driver Board (PL 12.1.12)	8-101
Rear Fan (PL 12.1.2)	8-102
Card Cage	8-103
Housing Assembly Contact (PL 12.1.14)	8-106
Engine Control Circuit Board (PL12.1.1)	8-107
Image Processor Board (PL12.1.4)	8-110

Optional High Capacity Feeder Disassembly	8-111
Cover Front (PL14.2.4)	8-111
Cover, Right (PL14.2.1) and Cover, Left (PL14.2.3)	8-112
Turn Chute Assembly (PL14.3.7).	8-113
Tray 3 Harness Assembly (PL14.5.3), Tray 4 Harness Assembly (PL14.5.4), and HCF Plug Harness Assembly (PL14.5.2)	8-114
Circuit Board, HCF (PL14.5.1)	8-116
Drive Feeder Assembly (PL14.5.5).	8-117
Indicator Assembly (PL14.5.9)	8-118
Right Tray Guide (PL14.3.5)and Low Paper Lever (PL 14.5.8)	8-119
Left Tray Guide (PL14.3.3).	8-122
Link Actuator (PL 14.4.6).	8-124
HCF Paper Pick Assembly (PL14.4.1)	8-125
Idler Gear (PL14.5.6)	8-126
No Paper, Low Paper Sensor (PL14.5.7)	8-127
Paper Size Switch Assembly (PL14.3.6)	8-128
Casters, Locking (PL 14.2.5)/Non-Locking (PL 14.2.6)	8-129
Optional 500-sheet Feeder Disassembly	8-130
Cover Front (PL15.2.4)	8-130
Cover, Right (PL15.2.2) and Cover, Left (PL15.2.1)	8-131
Turn Chute Assembly (PL15.3.9).	8-132
Tray 3 Harness Assembly (PL15.5.3) and STF Plug Harness Assembly (PL15.5.2)	8-133
Circuit Board, STF (PL15.5.1)	8-135
Drive Feeder Assembly (PL15.5.5).	8-136
Indicator Assembly (PL15.5.8)	8-137
Right Tray Guide (PL15.3.5)and Low Paper Lever (PL 15.5.7)	8-138
Left Tray Guide (PL15.3.3).	8-141
Link Actuator (PL 15.4.6).	8-143
STF Paper Pick Assembly (PL15.4.1)	8-144
No Paper, Low Paper Sensor (PL15.5.6)	8-145
Paper Size Switch Assembly (PL15.3.6)	8-146

9 Parts List

Serial Number Format	9-2
Using the Parts List	9-3
Print Engine Parts	9-4
PL 1.1 Covers	9-4
PL 2.1 Universal Paper Tray.	9-7
PL 3.1 Paper Feed I	9-8
PL 3.2 Paper Feed II.	9-10
PL 3.3 Paper Feed III	9-12
PL 4.1 Housing Assembly Retard	9-14
PL 5.1 Chute Assembly In	9-16
PL 6.1 Chute Assembly Out	9-18
PL 7.1 Chute Assembly Exit.	9-22

PL 8.1 Transfer Roller & Fuser Assembly (RMIs)	9-24
PL 9.1 Xerographics	9-26
PL 10.1 Holder Toner Cartridge Assembly	9-28
PL 11.1 Frame and Drive Assemblies	9-30
PL 12.1 Electrical	9-32
PL 13.1 Harness Assemblies	9-34
Optional High-Capacity Feeder	9-36
PL 14.1 Paper Trays 3 & 4	9-36
PL 14.2 High-Capacity Feeder Covers	9-37
PL 14.3 High-Capacity Feeder Guides and Turn Chute Assembly	9-38
PL 14.4 Paper Pick Assembly Trays 3 & 4	9-40
PL 14.5 High-Capacity Feeder Harness, Board and Motor	9-42
Optional 500-sheet Feeder	9-44
PL 15.1 Paper Tray 3	9-44
PL 15.2 500-sheet Feeder Covers	9-45
PL 15.3 500-sheet Feeder Guides and Turn Chute Assembly	9-46
PL 15.4 Paper Pick Assembly Tray 3	9-48
PL 15.5 500-sheet Feeder Harness, Board and Motor	9-50
Xerox Supplies and Accessories	9-51

10 Wiring Diagrams

Plug/Jack Locator Maps	10-2
Map 1	10-6
Map 2	10-7
Map 3	10-8
Map 4	10-9
High-Capacity Feeder Plug/Jack Locator Table	10-10
Map 5	10-11
500-sheet Feeder Plug/Jack Locator Table	10-12
Map 6	10-13
Print Engine Wiring Diagrams	10-14
Notations used in Wiring Diagrams	10-14
Main Wiring Diagram	10-15
Power Supplies	10-16
Paper Tray 2	10-17
Drive Section	10-18
Developer Section 1	10-19
Developer Section 2	10-20
Fuser Assembly	10-21
Laser Unit	10-22
Xerographics 1	10-23
Xerographics 2	10-24
Paper Feed	10-25
Image Processor Board	10-26

Printer Options Wiring Diagrams.	10-27
High Capacity Feeder Main Wiring Diagram.	10-27
Drive Section (HCF)	10-28
Paper Tray 3	10-29
Paper Tray 4	10-30
500-sheet Feeder Main Wiring Diagram.	10-31
Drive Section (STF)	10-32
Paper Tray 3	10-33

Reference

Printer Status Codes	A-2
--------------------------------	-----

Index

General Information

In this chapter...

- Printer Introduction and Overview
- Printer Configurations
- Parts of the Printer
- Phaser 6250 Front Panel Configuration
- Image Processor Board
- Routine Maintenance Items
- Printer Specifications

Chapter 1



Printer Introduction and Overview

The Xerox Phaser® 6250 Color Laser Printer Service Manual is the primary document used for repairing, maintaining, and troubleshooting the printer.

To ensure complete understanding of this product, participation in Xerox Phaser 6250 Service Training is strongly recommended.

Phaser 6250 Color Laser Printer shown with the Optional High-Capacity Feeder

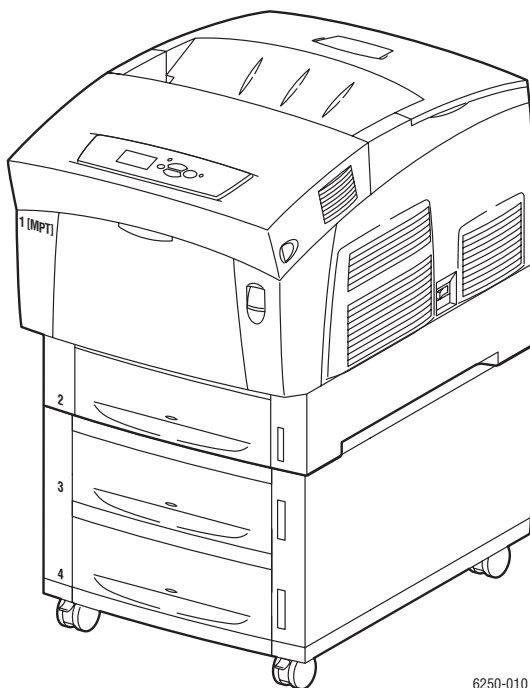

6250-010

Printer Configurations

The Phaser 6250 Printer combines a single-pass, tandem color laser design, with an image processor supporting PostScript 3 and PCL5c page description languages. The printer is a high performance, A4, 26 page per minute (ppm) desktop color laser printer supporting resolutions up to 2400 x 600 dots-per-inch (dpi).

The Phaser 6250 comes in five configurations. The main differences are optional networking, standard memory, optional high-capacity feeder, duplexing (2-sided printing) capabilities, and optional internal hard drive.

A replaceable “Configuration Chip” holds configuration information that enables or disables built-in features as described below.

Features	Printer Configuration				
	6250B	6250N	6250DP	6250DT	6250DX
Max Print Speed	26	26	26	26	26
Memory (Mbytes)	128	256	256	512	512
PostScript Fonts	137	137	137	137	137
PCL Fonts	81	81	81	81	81
Embedded PCL	Yes	Yes	Yes	Yes	Yes
Job Pipelining	No	Yes	Yes	Yes	Yes
Secure, Proof, and Saved Print Jobs	No	Opt*	Opt*	Opt*	Yes
PDF 1.4 support	No	Opt*	Opt*	Opt*	Yes
Banner-Size printing	No	Opt*	Opt*	Yes	Yes
Default Resolutions (dpi)	2400x600	2400x600	2400x600	2400x600	2400x600
Photo Mode	No	Yes	Yes	Yes	Yes
Job Collation	No	Opt*	Opt*	Opt*	Yes
Auto-Duplex	No	No	Yes	Yes	Yes
Single Tray, 500-Sheet Feeder Tray 3	Opt	Opt	Opt	Yes***	No
1000-Sheet High-Capacity Feeder Trays 3 & 4	Opt	Opt	Opt	Opt	Yes
Ethernet capabilities	Opt	Yes	Yes	Yes	Yes
USB, Parallel	Yes	Yes	Yes	Yes	Yes
Hard Drive	Opt**	Opt	Opt	Opt	Yes

* Requires optional hard drive

** Hard drive will work but does require N upgrade to support storage features

*** 500-Sheet Feeder is not stackable

Printer Memory and RAM Capabilities

The printer features two slots that accept 64, 128, and 256 Mbytes of SDRAM. All combinations are allowed for 64, 128, 256, 320, 384, and 512 Mbytes. Memory modules must have the following characteristics:

- PC133 DRAM Standard
- 144 Pin SODIMM
- Serial Presence Detect
- 3.3 Volt

The startup Page and the Configuration Page list the amount of RAM installed in the Printer.

If the memory does not meet the above specifications, it will be ignored by the printer.

Parts of the Printer

Exterior

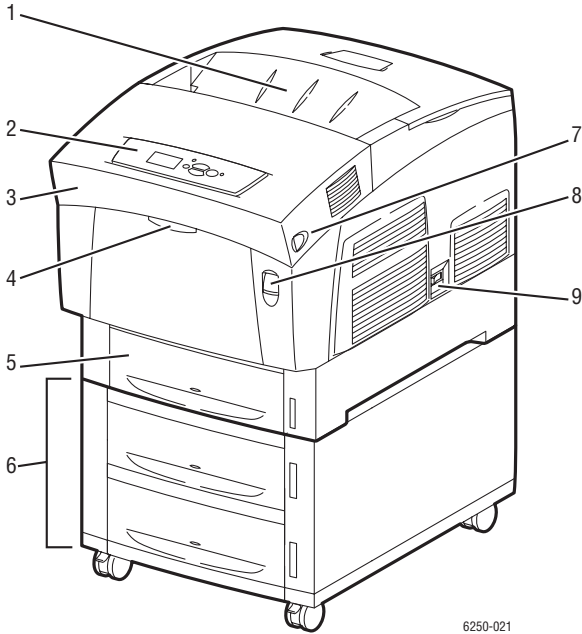

- | | |
|----------------------------------|--|
| 1. Top Cover (Output Tray) | 6. High-Capacity Feeder with Tray 3 and Tray 4 |
| 2. Control Panel (Front Panel) | 7. Door Latch B |
| 3. Front Cover | 8. Door Latch A |
| 4. Tray 1 (Multi-Purpose Tray) | 9. Power On/Off Switch |
| 5. Tray 2 (Universal Paper Tray) | |

Phaser 6250 Front Panel Configuration

The Front Panel contains one tricolor LED, a display window and six function buttons. These buttons navigate the menu system shown in the display window, perform various functions, and select modes of operation for the printer.

LED Indicators:

- Green = Ready to Print or Printing
- Flashing Green = Receiving, Processing Data, Printing or Power Saver Mode
- Flashing Yellow = Warning
- Flashing Red = Error

Front Panel Button Descriptions

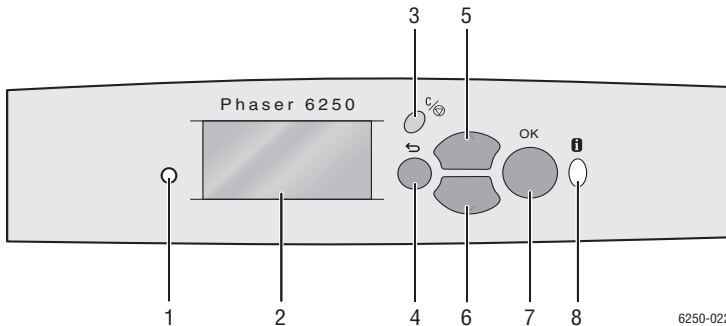

- | | | | |
|----------|-----------------------------|----------|---|
| 1 | LED (Power/Status) | 5 | Up Arrow Button - scrolls up the menu system |
| 2 | Graphic front panel display | 6 | Down Arrow Button - scrolls down the menu system |
| 3 | Cancel Button | 7 | OK (select) Button |
| 4 | Back Button | 8 | Information Button - for additional explanation or help |

Front Panel Shortcuts

Mode	Press this selection at Power On
Skip execution of POST diagnostics	OK
Print Service Diagnostics Map	INFO
Reset PostScript NVRAM	BACK+OK
Password Bypass	UP+DOWN
Enter Service Diagnostics	BACK+INFO

Rear View

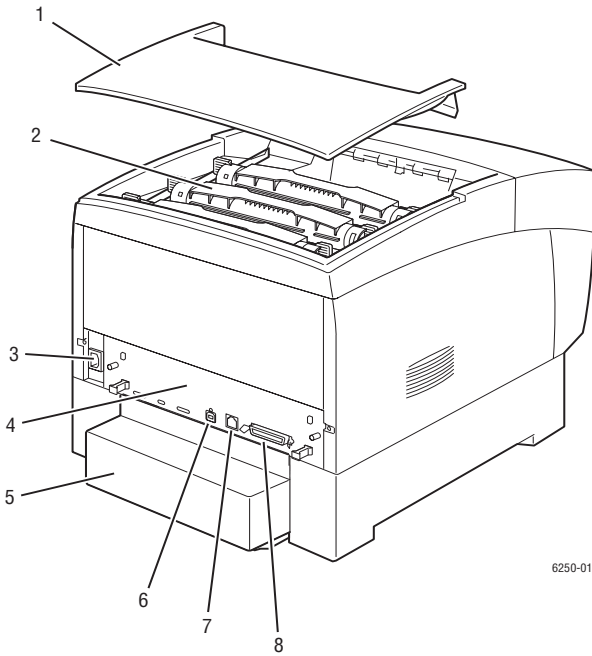

6250-019

- | | |
|--------------------------|---|
| 1. Top Cover | 5. Paper Tray Rear Cover |
| 2. Toner Cartridges | 6. USB Connector |
| 3. AC Power Connector | 7. Ethernet 10BaseT and 100Tx Connector |
| 4. Image Processor Board | 8. IEEE 1284 Parallel Connector |

Rear Panel Configuration Interfaces

- IEEE 1284 Parallel
- Ethernet 10BaseT and 100Tx
- USB

Image Processor Board

The components identified in the following figure need to be transferred from the old board to the new board when installing a new Image Processor Board in the printer. Data stored in the NVRAM can be transferred to the new board using the MCU NVRAM Store/Restore functions instead of by moving the component. Detailed information on the Store/Restore functions is available in "Service Diagnostic Tests" on page 3-9.

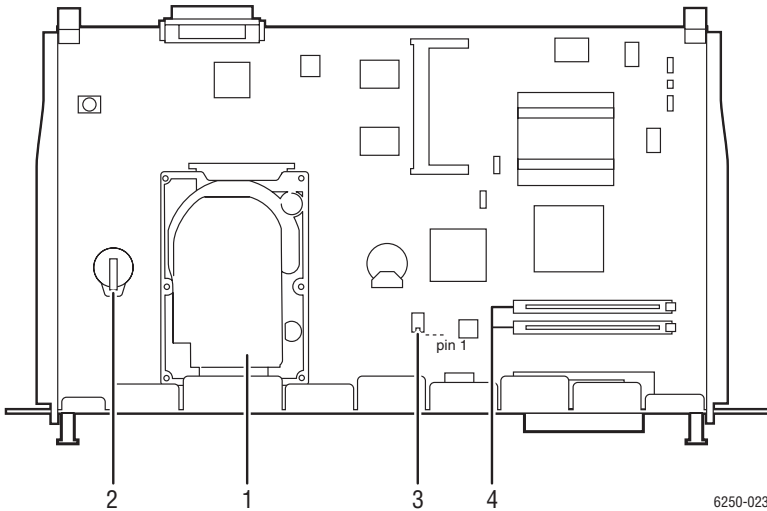

6250-023

1. Hard Drive (available option)
2. Configuration Chip
3. NVRAM
4. Memory (RAM) DIMM 1 and DIMM 2 (available option)

Routine Maintenance Items

A printer part or assembly that has a limited life, and requires periodic replacement.

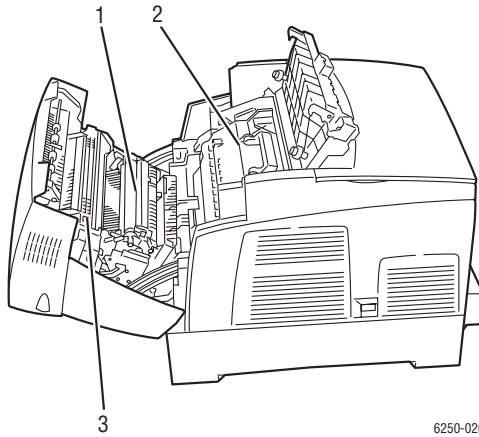

6250-020

1. Transfer Roller

3. Fuser Assembly

2. Imaging Unit

Consumables

Consumables consist of the four toner cartridges used in the printer.

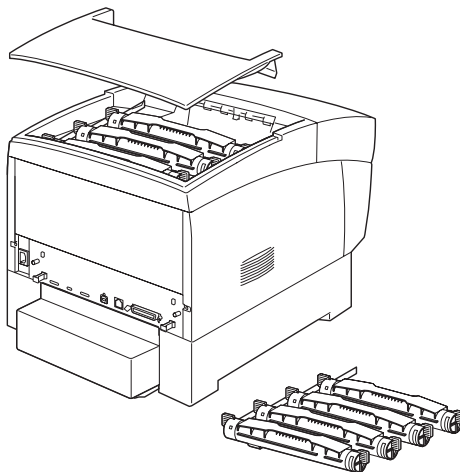

6250-495

Consumable Life Counter Behavior

Internal counters track Consumables and Routine Maintenance Items life usage and store the values in NVRAM. The image processor board monitors these counters in order to display the near end-of-life and end-of-use messages.

Life ratings are based on A-size sheets at 5% coverage. Imaging Unit life ratings are based on average 4 page job length.

Consumables	Print Life
Toner Cartridges	
High-Capacity	8,000
Standard Capacity	4,000
Routine Maintenance Items	
Imaging Unit	30,000
Fuser Assembly	100,000
Transfer Roller and Waste Box	15,000
Feed Roller Kit*	up to 100,000

* No life tracking for this item

Printer Specifications

Physical Dimensions and Clearances

Print Engine Dimensions	Value
Height:	445 mm (17.52 in.)
Width:	439 cm (17.28 in.)
Depth:	638 mm (25.12 in.)
Weight:	Approximately 36.5 kg (80.5 lb.) Print engine Approximately 56.5 kg (124.5 lb.) with Paper Tray(s) installed

Optional High-Capacity Feeder Dimensions	Value
Height:	336 mm (13.23 in.) Optional Paper Tray Assembly
Width:	439 cm (17.28 in.)
Depth:	563 cm (22.17 in.)
Weight:	Approximately 15 kg (33 lb.) no Paper Tray(s) installed Approximately 20 kg (44 lb.) with Paper Tray(s) installed

Optional 500-sheet Feeder Dimensions	Value
Height:	172 mm (6.77 in.) Optional Paper Tray Assembly
Width:	439 cm (17.28 in.)
Depth:	563 cm (22.17 in.)
Weight:	Approximately 7 kg (15.4 lb.) no Paper Tray installed Approximately 12 kg (26.4 lb.) with Paper Tray installed

Clearance	Value
Top:	350 mm (13.78 in.)
Left:	100 mm (3.94 in.)
Right:	150 mm (5.91 in.)
Front:	600 mm (23.62 in.)
Rear:	200 mm (7.87 in.)
Mounting surface level tolerance:	Within 3 degrees of horizontal with all four feet in contact with the surface.

Functional Specifications

Functional Specifications

Characteristic	Specification			
Printing process	Imaging System - 4-tandem drums, electro-photographic system using intermediate drum transfer rolls (IDTs). Exposure System - Semiconductor laser, simultaneous scanning by 4 beams. Development System - Dry type 2-component developer. Fusing System - Heat fusing, free nip-belt system.			
Color medium	Yellow, Magenta, Cyan, and Black Toner Cartridges			
Resolution / Addressability	Draft	600 x 600 dpi		
	Enhanced	2400 x 600 dpi (Default)		
	Photo	2400 x 600 dpi*		
	* Not available on the Phaser 6250B.			
Operating Modes	Print Mode: Print Engine capable of making prints immediately. Ready Mode: 20 seconds from completion of a print. Sleep/ Low Power/ Power Saver Mode: Entered after a specified period of Print Engine inactivity since completion of the last print.			
Continuous Operating Printing Speed	Mode	Paper Size / wt g/m²	Simplex	Duplex
ppm = pages per minute	600/2400 dpi	Letter / A4		
		65 -130	26/24 ppm	15 ipm
		100-163	13/12 ppm	7.8 ipm
ipm = inches per minute	600/2400 dpi	160-216	13/12 ppm	N/A
		Legal		
		65 -130	19 ppm	16 ipm
		100-163	10 ppm	7.8 ipm
		160-216	10 ppm	N/A
	600/2400 dpi	Envelope/Postcard		
		160-216	13 ppm	N/A
	600/2400 dpi	Letter / A4 / OHP	8.6/8 ppm	
		Letter / A4		
		Photo Glossy Paper	8.6/8 ppm	5 ipm
		100-200		
Cleaning Cycle interval for continuous printing	Print speed will be reduced if the print job is larger than the cleaning cycle interval.			
	IU Print Volume	Draft Pages	Enhanced Pages	Photo Pages
	0 - 5 K Pages	53	31	22
	5 - 10 K Pages	35	26	18
	10 - 15 K Pages	35	26	18
	15 - 20 K Pages	35	26	18
	20 - 25 K Pages	29	22	13
	25 - 30 K Pages	29	22	13
	>30 K Pages	29	22	13

Functional Specifications (Continued)

Characteristic	Specification				
First Print-Out (in seconds) (Letter/A4) (printer in Ready state)	Mode	Tray 1	Tray 2	Tray 3	Tray 4
	Simplex, 600 dpi	14.5	15	16.5	18
	Duplex, 600 dpi	23	23.5	25	26.5
	Simplex, half-speed	23.5	24.5	27.5	30.5
Duplex, half-speed	38.5	39.5	42.5	45.5	
Warm-up time	30 seconds from cold start (power off condition)				

Electrical Specifications

Characteristic	Specification			
Primary line voltages	110-127 V Printer - (90 - 140 V) 13 amp circuit 220-240 V Printer - (198 - 264 V) 7-8 amp circuit			
Primary line voltage frequency range	100-120 V Printer - 50/60 Hz \pm 3Hz 220-240 V Printer - 50/60 Hz \pm 3Hz			
Power consumption at rated voltage input	Mode	Condition	100/120 VAC	220/240 VAC
	Print Mode	Max..	1000 W or less	1000 W or less
	Ready Mode	Fuser On	180 W or less	180 W or less
	Sleep Mode	Fuser Off	45 W or less	45 W or less

Environmental Specifications

Characteristic	Specification	
Temperature:	Optimal print-quality range: 17 ^o to 26 ^o C (62 ^o to 80 ^o F)	
Operating	10 ^o C to 32 ^o C (50 ^o F to 90 ^o F)	
Transportation	-30 ^o C to +50 ^o C (-22 ^o F to 122 ^o F)	
Storage		
24 month maximum	Normal: 0 ^o C to 35 ^o C (32 ^o F to 95 ^o F)	
1 month maximum	Severe: -20 ^o C to 40 ^o C (-4 ^o F to 104 ^o F)	
Humidity	Optimal print-quality range: 35% to 70%	
Operating	10% - 85%	
Transportation	30% - 85%	
Storage	5% - 95%	
Altitude		
Operating	0 - 2,500 meters (8,000 ft.)	
Transportation	0 - 6,092 meters (20,000 ft.)	
Acoustic Noise	Printer Only	With Feeder Option
Idle	35.0db or less	35.0db or less
Printing	55.0db or less (Full Speed) 52.0db or less (Half Speed)	55.0db or less (Full Speed) 53.0db or less (Half Speed)

Media and Tray Specifications

	Specification		Trays
Printable Area	Minimum margins = 5 mm (0.2 in.) on all sides Maximum paper size = 215.9 mm x 355.6 mm (8.5 in. x 14 in.) Minimum paper size = 88.9 mm x 139.7 mm (3.5 in. x 5.5 in.)		All Trays
Supported Media Sizes	Paper Type	Size	
	Letter	8.5 x 11 in.	All Trays
	Legal	8.5 x 14 in.	All Trays
	Executive	7.25 x 10.5 in.	All Trays
	Statement	5.5 x 8.5 in.	Tray 1 Only
	US Folio	8.5 x 13 in.	All Trays
	A4	210 x 297 mm	All Trays
	A5*	148 x 210 mm	Tray 1 Only
	A6	105 x 148 mm	Tray 1 Only
	B5 JIS	182 x 257 mm	All Trays
	ISO B5	176 x 250 mm	Tray 1 Only
	Custom Size & Banner	8.5 x 22.86 in.	Tray 1 Only
Supported Media Types and Weights	Type	Weight	
	Plain Paper	64- 90 g/m2 (17 - 24 lb. Bond)	All Trays
	Heavy Plain Paper	85 - 130 g/m2 (22 - 28 lb. Bond)	All Trays
	Phaser 25-Series Premium Transparency Film (Only)		Tray 1 & 2
	Thin Card Stock	100 - 163 g/m2 (26 - 60 lb. Cover)	Tray 1 Only
	Thick Card Stock	160 - 216 g/m2 (59 - 80 lb. Cover)	Tray 1 Only
	Labels	N/A	Tray 1 & 2
	Letterhead	85 - 130 g/m2 (22 - 28 lb. Bond)	All Trays
	Glossy Coated Paper**	120 - 163 g/m2 (81 - 110 lb.)	All Trays
	Business & Greeting Cards	N/A	Tray 1 Only
	CD/DVD Labels and Inserts	N/A	Tray 1 Only
	Digital Photo Paper	163 g/m2 (60 lb. Cover)	Tray 1 Only
	Phaser Premium Post-cards	176 g/m2 (65 lb. Cover)	Tray 1 Only
	Phaser Glossy Trifold Brochures	176 g/m2 (65 lb. Cover)	Tray 1 Only
	Phaser Weatherproof Paper	100 g/m2 (27 lb. Bond)	Tray 1 & 2
Supported Envelopes*	Envelopes Weight	20 - 24 lb. Bond	Tray 1 Only
	Commercial #10	4.12 x 9.5 in	
	Monarch Envelope	3.87 x 7.5 in	
	A7 Envelope	5.25 x 7.25 in	
	Custom		
	DL Envelope	110 x 220 mm	
	C5 Envelope	162 x 229 mm	
	C6 Envelope	114 x 162 mm	
	B5 Envelope	176 x 250 mm	
	Envelopes with hot melt type glue are not supported in this printer. Do not use envelopes with windows or metal clasps.		

* Some wrinkling and embossing may occur when printing envelopes.

Specification		Trays	
Speciality Media	Phaser 25-Series Premium Transparencies		
	Letter	216 x 279 mm 8.5 x 11 in.	
	A4	210 x 297 mm 8.27 x 11.69 in.	
	Other sizes will be handled through Tray 1 with use of the custom size option.		
	Phaser Premium Postcards		
	Letter	216 x 279 mm 8.5 x 11 in.	
	A4	210 x 297 mm 8.27 x 11.69 in.	
	Phaser Glossy Trifold Brochures		
	Letter	216 x 279 mm 8.5 x 11 in.	
	A4	210 x 297 mm 8.27 x 11.69 in.	
Weather Proof Paper			
	Letter	216 x 279 mm 8.5 x 11 in.	
	A4	210 x 297 mm 8.27 x 11.69 in.	
Tray Capacity	Universal Tray	Tray 1/MPT	
	Standard Paper	500 Sheets	100 Sheets
	Transparency	100 Sheets***	50 Sheets
	Envelopes	N/A	10 each

- * A5 paper is supported from all trays in Japanese models only
** Glossy paper can be used in all trays on the 6250
*** Tray 2 only

Note

For duplex configured printers, auto duplex operation is available through Tray 1 (MPT) and Trays 2, 3, and 4. Refer to the Paper Tips page for information on which paper types can be used for duplex printing.

Theory of Operation

In this chapter...

- Overview
- Printer Controls
- Paper Path of the Printer
- Major Assemblies and Functions

Chapter 2

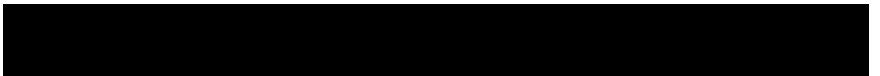

Overview of the Phaser 6250 Color Laser Printer Theory of Operation

Summary of the Printing Process

The Phaser 6250 Color Laser Printer is a 'full-color laser printer', that utilizes electrophotographic recording principals to place a full color image onto the print media. The system, contains a drum and developing unit for each color (yellow, magenta, cyan and black (YMCK)), and places the toner image of each color onto print media producing full-color prints through three transfer units (primary transfer units IDT1 (2 ea) and secondary transfer unit IDT2 (1 ea)).

A summary description of the printing process is presented in the following Steps, see the illustration on the following page as a reference:

- 1. Charging:** The charge roller (RTC) is negatively charged by the high voltage power supply (HVPS) and is kept in contact with the drum surface to provide a uniform negative charge on the drum as it rotates at a constant speed. This occurs simultaneously for YMCK. The refresher is a conductive brush that is also negatively charged by the HVPS to pick off any toner particles left on the drum after image transfer to the IDT.
- 2. Exposure:** The laser unit emits laser beams in response to image data from the Image Processor board. The laser beams are directed onto the drum surface through a system of mirrors and lenses. A rotating polygonal mirror causes the laser beams to scan the drum surface from end to end (axially) as it rotates. The beams are turned on to print a pixel and off when no printing is required. The negative charge on the drum surface is reduced at each point where the energized laser beam strikes, to form an invisible electrostatic latent image on the drum surface. This process is performed simultaneously for YMCK.
- 3. Development:** Toner is electrostatically attached to the invisible latent image on the drum surface to form the visible image on the drum. Toner is fed into the developer using the agitator and auger. The toner and the carrier in the developer form a homogeneous layer on the magnet roller in the developer. The magnet roller turns against the surface of the drum and is kept at a constant negative potential. At areas on the drum surface where the negative charge has not been reduced by the impact of laser light, potential between the drum and the toner particles is lower than that between the magnet roller and the toner particles. At areas where the drum charge has been reduced, the potential between the particles and drum is higher than between the magnet roller and toner particles are attracted to the drum. A thin semiconductive sleeve on the magnet roller is vibrated by an AC voltage to encourage migration of the toner particles to the drum. When the toner particles attach to the drum, the negative charge of the particles reduces drum potential at that point, thus reducing the attraction of additional toner particles. This process is performed simultaneously for YMCK.
- 4. Primary Transfer (drum --> IDT1):** The toner image formed on the individual drum surface is transferred onto the surface of the IDT1 (intermediate Drum Transfer 1: intermediate transfer roller 1). There are two IDT1's: one for yellow and magenta and one for cyan and black. IDT1 is conductive and receives a high positive charge from the HVPS. The negatively charged toner image on the drum

surface is attracted by the high positive potential and transfers to IDT1. During this transfer, the remaining negative charge on the drum is neutralized by the high positive charge on IDT1.

- 5. Secondary Transfer (IDT1 --> IDT2):** The toner images formed on both IDT1 surfaces are then transferred onto the surface of IDT 2 to create a complete, 4-color toner image. IDT2 is also conductive and receives a positive voltage from the HVPS. The received voltage puts IDT2 at a higher potential than IDT1 thus attracting the toner image and facilitating the transfer.
- 6. Cleaning:** The IDT1 cleaner consists of a conductive roller brush rotating in contact with IDT1 after the point where the toner is transferred to IDT2. The cleaner receives a high positive voltage from the HVPS allowing it to electrically attract any toner particles remaining on IDT1. Toner remaining on both IDT1's after the image transfer to IDT2 is temporarily stored in the IDT1 cleaners.
- 7. Tertiary Transfer:** The finished toner image on IDT2 is transferred onto the print media using the voltage supplied by the transfer roller. The conductive transfer roller receives a high positive voltage from the HVPS that puts it at a higher potential than IDT2. Since the transfer roller is located behind the print media, the 4-color toner image is attracted to the high potential and deposits on the surface of the print media.
- 8. Cleaning:** The IDT2 cleaner consists of a conductive roller brush rotating in contact with IDT2 after the point where the toner is transferred to the print media. The cleaner receives a high positive voltage from the HVPS allowing it to electrically attract any toner particles remaining on IDT2. Toner remaining on IDT 2 after the image transfer to the print media is temporarily stored in the IDT2 cleaner.
- 9. Static Elimination:** The positive charge on the print media can cause image quality problems by scattering toner. To prevent this, negative DC voltage from the HVPS is applied to the back side of the print media by the Detack Saw, located on the Transfer Roller Assembly. This negative charge neutralizes and eliminates the charge on the print media resulting from the tertiary transfer.
- 10. Fixing:** The finished toner image is unstable and easily smeared. To fix the image, the print media goes through the Fuser Assembly where it passes between a pressure belt and the heat roller. The toner is fused onto the print media by the combination of heat and pressure.
- 11. Cleaning:** During the general cleaning process, the voltage applied to the IDT rollers and drums go through a cycle of changes to move the negative and positive charged toner particles from the cleaners and IDTs and then the transfer roller. The toner stored in the IDT1 cleaner, the IDT 2 cleaner and on the transfer roller is removed and deposited into the transfer roller waste recovery bin. Toner from the charge roller and refresher is also removed and deposited into the transfer roller waste recovery bin. In each case the voltage at the point of attraction is set high and the voltage at the point of disposal is set to 0V with the result that the toner is moved to the high potential until at last it is deposited on the transfer roller. Toner is removed from the transfer roller by the attached cleaning blade and deposited in the attached recovery bin.

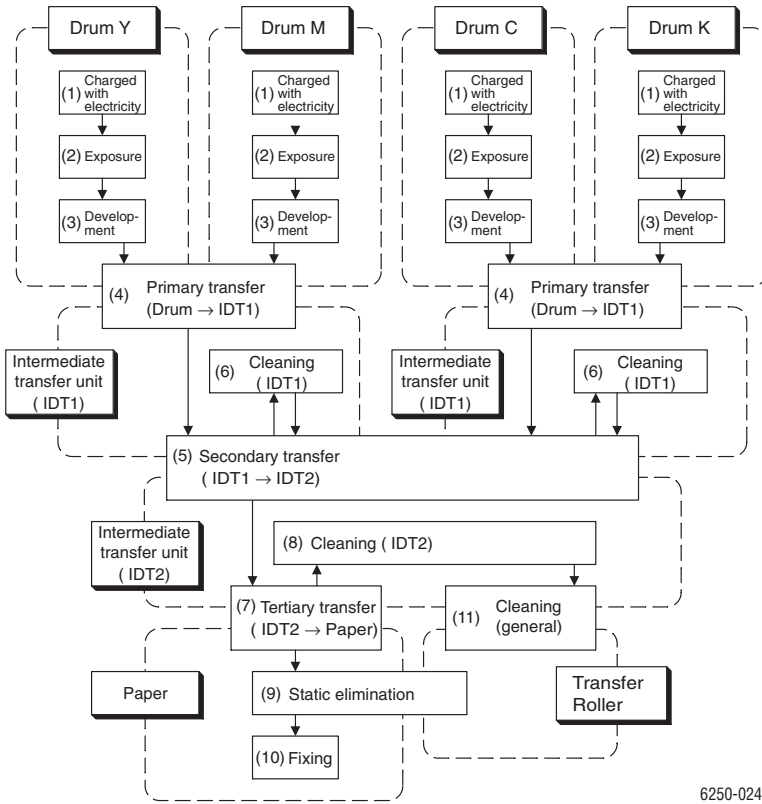

6250-024

Printing Process Flowchart

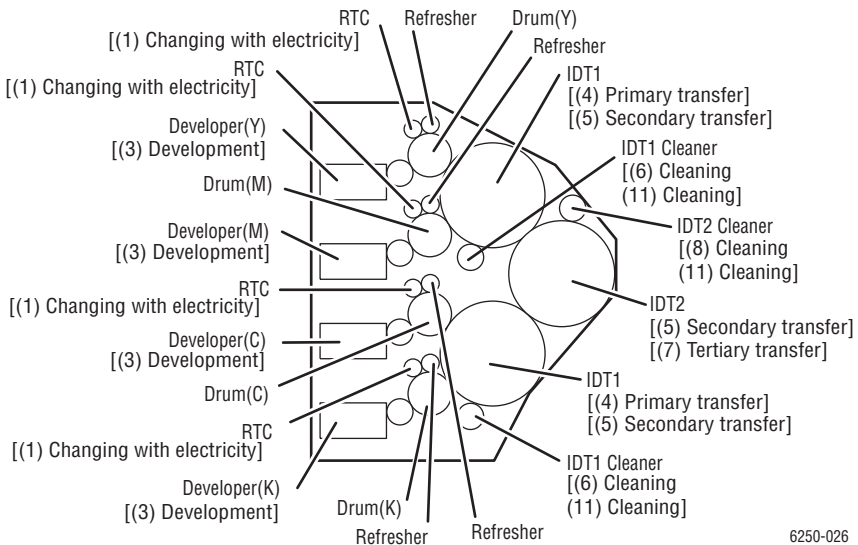

6250-026

Printing Process Components

Print Modes

There are three print modes: Draft mode, Enhanced mode, and Photo mode. These are based on the resolution (600 dpi or 2400 dpi) and, depending on the media type, can also be affected by process speed (full speed/half speed/one-third speed).

- Draft mode: 600 X 600 dpi resolution. Used to check layout. Provides reduced toner usage.
- Enhanced mode: 2400 X 600 dpi resolution. General purpose mode for crisp bright color prints. Recommended for most office use. It is the default mode
- Photo mode: 2400 X 600 dpi resolution. Highest quality color print with very smooth color shades. When using photo paper or OHP, gloss is raised by setting the process speed to one-third.

Printer Controls

Paper Size Control

The paper size selection is controlled by three paper size switches located in each paper tray slot. The switch condition is set by moving the paper guide in the tray. This in turn sets the plastic “fingers” on the side of the paper tray to a specific position that activates the correct switch combination for the selected paper size.

Paper Size Switches are indicated as SW1, SW2, and SW3

Paper Size	Paper Size Switch		
	SW1	SW2	SW3
LEGAL14"	ON	ON	ON
US FOLIO (LEGAL 13)"	ON	ON	OFF
EXECUTIVE	ON	OFF	ON
B5	ON	OFF	OFF
A4	OFF	ON	ON
A5 (for reference only, supported in Tray 1 [MPT] only)	OFF	ON	OFF
LETTER	OFF	OFF	ON
No Tray	OFF	OFF	OFF

Selective Control; Paper Pick

Unless changed in printer setup, the default tray is Tray 2. Trays in the optional High-Capacity Feeder are identified as Tray 3 and Tray 4. The tray in the optional 500-sheet Feeder is identified as Tray 3.

Laser Light Intensity Control

The Laser Unit in the Phaser 6250 printer has four laser diodes: one each for yellow, magenta, cyan, and black. The diodes control circuits adjust the light intensity for each color automatically. Image data is transmitted to the laser diodes in the Laser Unit as digital signals. The laser diodes convert the image data from digital signals to optical signals. The laser assembly monitors and adjusts the light intensity of the laser beams to attain a stable electrostatic image. Variations in drum sensitivity may prevent the system from obtaining a proper electrostatic image.

Process Control

For stable printing, the parameters related to forming both the electrostatic and toner image must be continuously monitored and adjusted by the printer. Parameter correction and control over the entire printing process is called “process control”.

There are two main areas of control:

- Bias Control
- Toner Density Control

To supplement these two controls, the following are provided:

- High-Area Coverage Mode Control
- Admix Mode Control
- Toner Density Control (CTD) Sensor (ADC - Automatic Density Control) LED light density setting.

Bias Control

To attain stable image density, toner density is monitored for each color and the drum charging voltage and biasing DC voltages are adjusted according to the monitored results for each color.

The bias control adjustment is made immediately before the start of printing, if any of the following conditions is satisfied:

- First print produced after the power on.
- Cumulative print count exceeds 16 since power on.
- A cleaning cycle is executed during continuous printing.

Bias control operates as follows:

1. The Temperature/Humidity Sensor sets the target values of the drum charging voltage and biasing DC voltage.
2. Bias control test patches (see the adjacent figure for patch configuration) of each of the four toner colors (yellow, magenta, cyan, and black) are generated and transferred to the Transfer Roller.
3. The CTD (ADC) Sensor compares an area on the Transfer Roller where no toner is present with the test patches to determine toner density for each of the four colors.
4. The density measured in Step 3 is compared with the target value set in Step 1 and the resulting difference is used to adjust the drum charging voltage and the biasing DC voltage for each toner color.

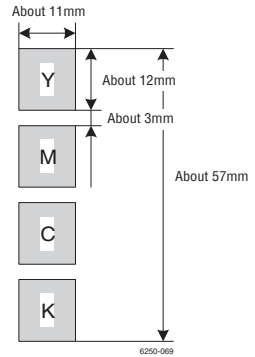

Toner Density Control

Toner density must be kept constant to attain a stable print image. To achieve this goal, the rate at which toner is dispensed must be adjusted to exactly match the rate at which it is consumed. There are two systems that work in conjunction to control toner density: the Pixel Count Dispense Control (PCDC) and the Toner Density Control (CTD). (The CTD uses data from the ADC sensor, measured as described in the preceding paragraphs covering bias control.)

PCDC: The amount of toner consumed in the developing process is calculated by counting the digital pulses applied to the Laser Unit. The toner motor is then driven for a period determined by the calculated result to supply toner to the developer, equivalent to the amount dispensed.

CTD (ADC): The toner test patches of each color (yellow, magenta, cyan, and black), are generated and transferred to the transfer roller as specified in the Bias Control section. The CTD (ADC) sensor measures the density of each patch. The printer adjusts the toner dispense time, which changes the quantity of toner to be dispensed. This calculation is made separately for each color. The CTD adjustment is made following completion of printing if either of the following conditions is satisfied:

- Cumulative print count since power on exceeds 16 pages.
- When a cleaning cycle is executed during continuous printing.

If either of the preceding control calculations results in an adjustment to the toner quantity to be dispensed, the result is calculated in terms of number of revolutions of the Toner Motor. For this description, this value is called the dispense count.

The dispense count calculated as specified above, is implemented over the next 8 prints. If 16 dispense counts are required as a result of low toner density during the CTD calculation, 2 dispense counts are added during each of the next 8 prints. This is in addition to any counts added or subtracted during each print as a result of PCDC.

If toner density is too great (excess toner) and 16 dispense counts are required to subtract this amount, the adjustment is accomplished by subtracting 2 counts from the calculated PCDC count over each of the subsequent 8 prints. If the excess amount cannot be subtracted in 8 print cycles, it is subtracted in the ninth and subsequent prints.

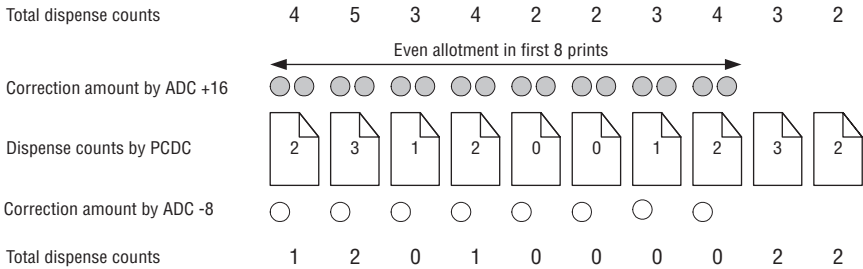

6250-067

High-Area Coverage Mode

Continuous printing of an image with density exceeding the toner dispense capability causes the toner density in the developer to be lowered below the target toner density. The high area coverage mode delays feeding of the next page, and dispenses toner during this time so that the toner density time reaches the specified value during continuous printing.

Admix Mode

If the high area coverage mode can not deal with the reduction of toner density in the developer or if the machine is moved to an environment with a different humidity level, the reference value for the toner density will change. This causes a large discrepancy between the measured values from the CTD sensor and the referenced value for the toner density.

Admix mode dispenses the toner immediately to prevent low-toner density. If the patch density result measured by the CTD Sensor is lower than the reference value from the toner density control, then the admix mode is initiated.

LED Light Density CTD (ADC) Control of Sensor

The CTD (ADC) sensor is a reflective sensor that emits light from an LED in the sensor and detects the reflected light from the transfer roller. For exact density measurement, the sensor output value (reflected light density) must be the specified value when no toner is put on the Transfer Roller. The reflected light density varies

depending on the Transfer Roller surface condition or dirty condition of CTD (ADC) sensor surface. The light density emitted from the LED is controlled so that the reflected light density meets the specified value.

This control is implemented in two ways:

- Sets the light density so that the light reflected satisfies a specific value.
- Adjusts the subsequent light density to be within a specific tolerance value.

1. Light Density Setting

The reflected light density can vary greatly if the transfer roller has been replaced or the CTD (ADC) sensor has been cleaned. To deal with this variance the light density is reset when the power is turned on or the front cover is opened and closed.

The intensity of the LED increases gradually and the set value is adjusted when the output of the CTD (ADC) sensor does not meet the specified value. If the output of the CTD (ADC) sensor does not reach the specified value, even though the light density is increased to the maximum limit, the controller signals the sensor is dirty. If the sensor output is extremely high, the controller will signal that the sensor is faulty.

2. Light Density Adjustment

At the execution of automatic density control, the light density adjustment is made just before the patches for toner density control are generated.

Light is emitted from the LED using the current light density setting, to check if the output value of the CTD (ADC) sensor is within the specified range. If the output value is low, light density is increased. If the output value is high, the light density is decreased.

If the output value is less than the first lower limit, the controller signals the sensor as dirty and generates a warning. If the output value is less than the second lower limit, the controller signals that the sensor is faulty and stops the printing.

Color Registration Control

The printer uses a quad system where drums and developers are used exclusively for each of the four colors (yellow, magenta, cyan, and black). Images are formed on the drums, in the respective colors, and then layered to form one image. To avoid a positional shift between the different color images, the color registration control calculates how much the registration has shifted by comparing each of the other color patches in the registration string to the black bar that precedes it. Shift is corrected by adjusting the laser write timing to compensate.

Color registration control is made depending on the internal temperature and print count at the execution of process control.

+n of this control is outlined below:

1. With no toner on the Transfer Roller, the output value of Sensor, CTD (ADC) is measured to determine the threshold value.
2. Patches for color registration control are generated on the Transfer Roller. These patches are composed of 10mm lines of each toner color in the following order: K, C, K, M, K, and Y with each color dispensed in the amount of four dispense counts. The string of patches is led by a black trigger patch that is larger than the registration patches.
3. The density of patches generated by the CTD (ADC) sensor is measured.
4. The amount of registration shift is calculated from the threshold value determined in Step 1 and the patch density measured in Step 3.
5. The laser write timing is changed to compensate for the amount of registration shift.

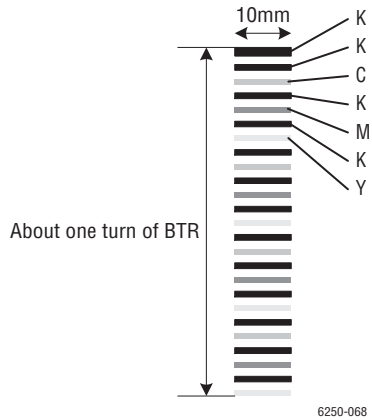

Transfer Roller Assembly Control

Detecting the Installation of the Transfer Roller Assembly

Although there is no separate sensor for this, the output of the CTD Sensor is used to detect installation or absence of the Transfer Roller when power to the printer is turned on, or the front cover is opened and closed.

Light emits from the LED of the CTD sensor with the specified intensity and if the output of the CTD Sensor is greater than the specified value the controller signals that the Transfer Roller is present (installed).

If printing is stopped by a jam, the toner image will be placed on the Transfer Roller. In this case the sensor output result is low, causing the controller to report the Transfer Roller as missing. To prevent this, the Transfer Roller is rotated a half turn if output is lower than the specified value. If the output of the CTD sensor is than greater than the specified value, the controller reports installation of the Transfer Roller. If the output remains less than the specified value, the controller reports that the Transfer Roller is not installed.

Detecting the Life of the Transfer Roller Assembly

The Transfer Roller Assembly consists of a bias transfer roller and a waste toner recovery space. End of life of the Transfer Roller is detected when the waste toner recovery space becomes full.

The full waste toner recovery space is detected by the Toner Full Sensor.

1. Status of the waste toner recovery space is checked:
 - When the power is turned on.
 - When the front cover is opened and closed.
 - When paper exits the print engine.
2. “Transfer Roller is at End of Life” **error** message is generated when the toner full sensor detects the waste toner recovery space is full.
3. “Replace Transfer Roller ” **warning** message is generated if the print count and the toner dispense time are counted and the total count exceeds 15,000 prints.
4. “Transfer Roller is at End of Life” **error**/ “Replace Transfer Roller ” **warning** messages are reset if the toner full sensor does not detect a full waste toner recovery space when power is turned on, or the front cover is opened and closed.

Toner Control

Toner Cartridge installation is detected by the Toner Present (CTG-In) Switch, and the presence of toner is detected by the Toner Low Sensor. These switches and sensors are provided for each toner color (CMYK), and detection is made for each individually.

Toner Low Sensor

The toner low sensor checks one color every 3.5 seconds, requiring 14 seconds to detect all four colors.

The toner low sensor is attached to the Toner Cartridge Holder Assembly. It detects toner dispensed by the toner motor from the toner cartridge into the auger tube.

The toner low sensor can make a false detection if toner has stuck to the surface of the sensor. To prevent this, a film attached near the auger in the toner cartridge holder assembly cleans the sensor surface whenever toner is dispensed. This film rotates with the auger as toner is dispensed, scraping toner off the toner low sensor surface.

The toner low sensor may detect toner even if toner is not present or may not detect the toner even if toner is present, depending on the film position when the toner motor stops. This is avoided by the printer's internal toner presence control.

Toner Presence Control

1. Checks for toner presence when the power is turned on, or after the front cover is opened and closed. Checks every 14 seconds when printing.
2. The "Toner Empty" **warning** is displayed when the counter on the Customer Replaceable Unit Monitor (CRUM) indicates that the toner is empty.
3. The "Toner Empty" **error** is displayed when the toner low sensor detects that toner is empty.
4. When a new toner cartridge is installed ("Toner Empty **error**" not being generated), toner is dispensed for 1.7 seconds. At the next toner control timing, if the toner low sensor detects toner present, the "Toner Full", "Toner Empty Warning", and "Toner Empty Error" are reset. When toner is dispensed and the toner low sensor detects toner present three or more times consecutively, the controller regards this status as "Toner Present".
5. If the toner low sensor does not detect toner present, toner will be dispensed for 1.7 seconds again 5 seconds later. If toner present is not detected after executing toner dispense three times and if toner cartridge dispense time shows 0, "Remove Ribbon From 'x' Cartridge" error is displayed.

Fuser Control

Fuser Temperature Control

During fuser temperature control the printer's target temperature is set. The heat roller surface temperature is controlled to match the target temperature by turning the heater lamp on/off.

The heat roller surface temperature is detected by two sensors. A non-contact sensor in the middle of the roller is checked for 60ms and the Temperature Sensor at the edge of the roller is checked for 20ms to maintain an even temperature across the roller. If the results of the 80ms cycle show the temperature is higher than the target, the heater lamp is turned off. If the detection result is low, the heater lamp is turned on.

For the target temperature, different temperatures are set for standby, printing, and process control. The target temperature is also changed according to the inside temperature detected with the temperature/humidity sensor, print count, print mode, input power supply voltage and paper type.

Cool Down

During printing, the temperature distribution of the heat roller becomes uneven between paper and non-paper. To make the heat roller temperature as even as possible, a wait time is provided and the heater lamp is kept off. This is called the cool down.

A cool down is executed according to the number of sheets continuously printed when a set, printing with a certain type and size of print media is completed, and when the print media type or size is changed. The cool down, which results in a pause, occurs evenly in the middle of several hundred sheets of continuous printing.

Paper Path of the Printer

- ▶ : Laser beam
- - - -▶ : Paper path
- ▲ : Paper sensors

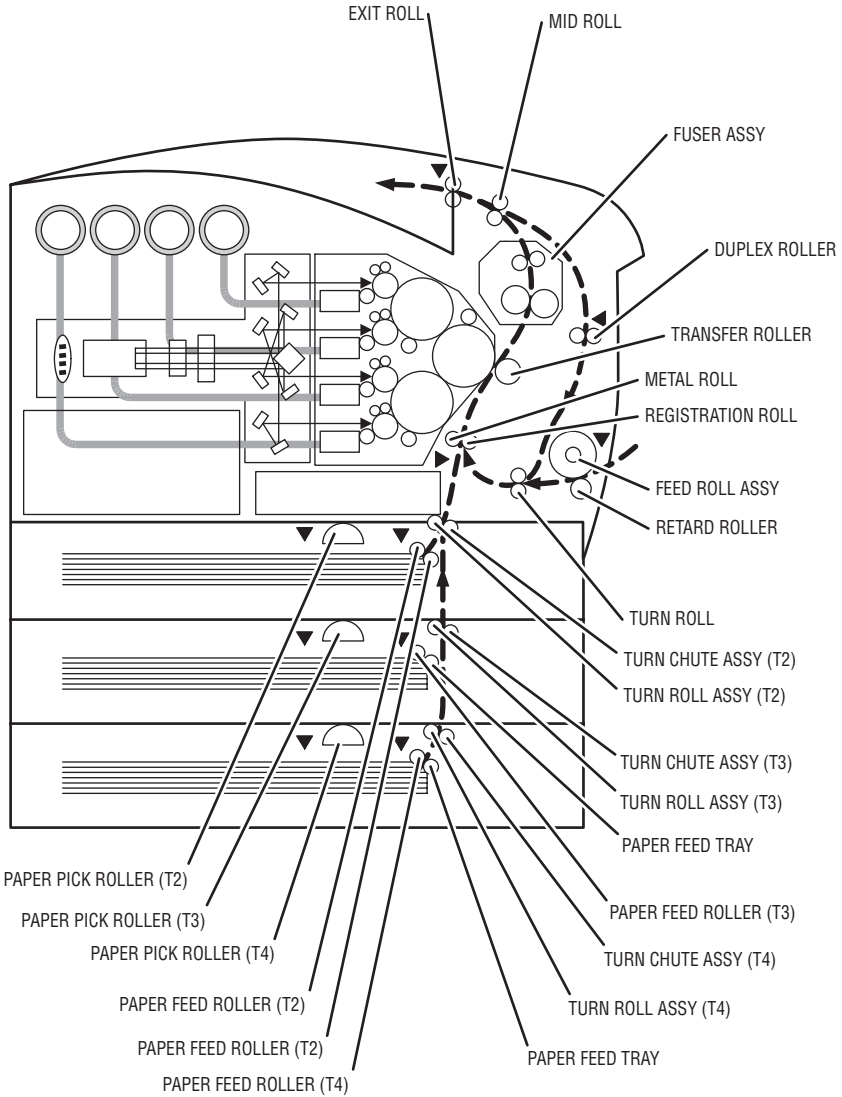

6250-054

Paper Path Route

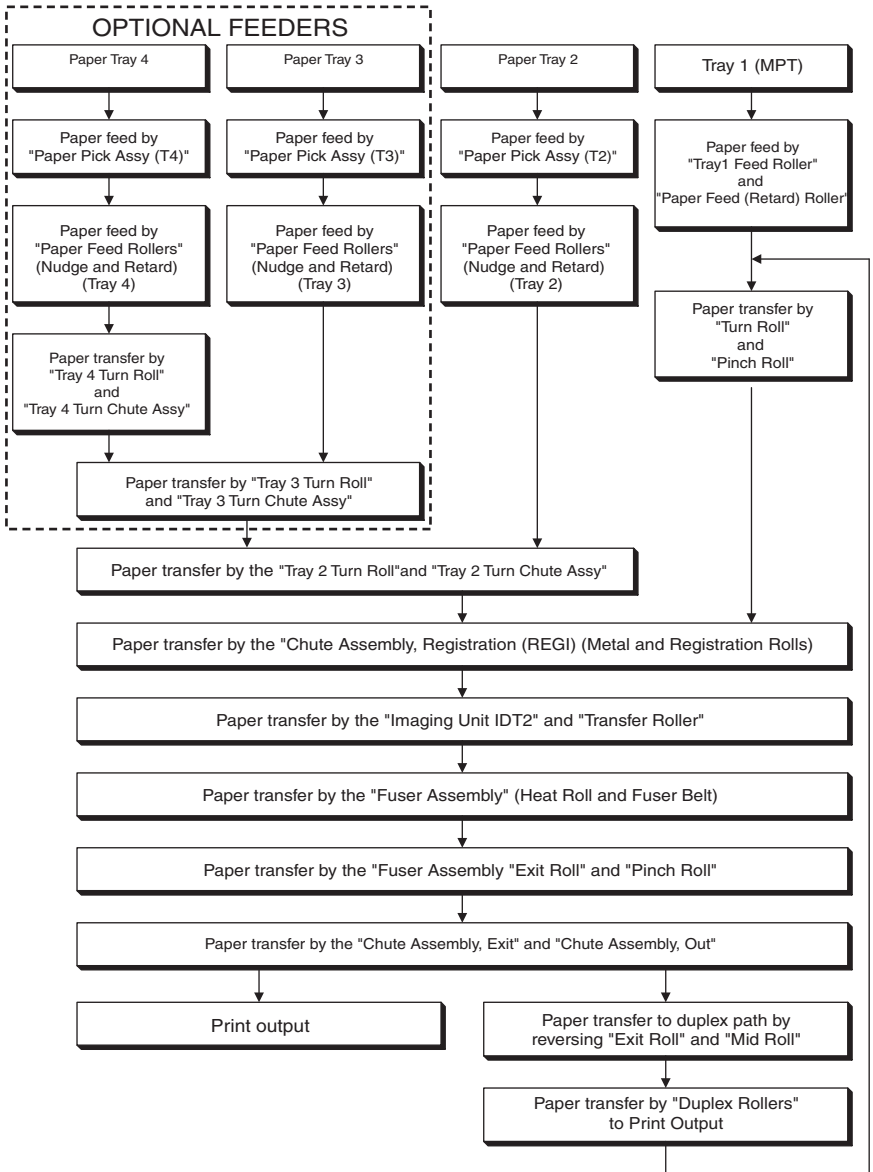

6250-493

Major Assemblies and Functions

The following section details all major components of the printer and their relative functions.

Frame and Drive Assemblies

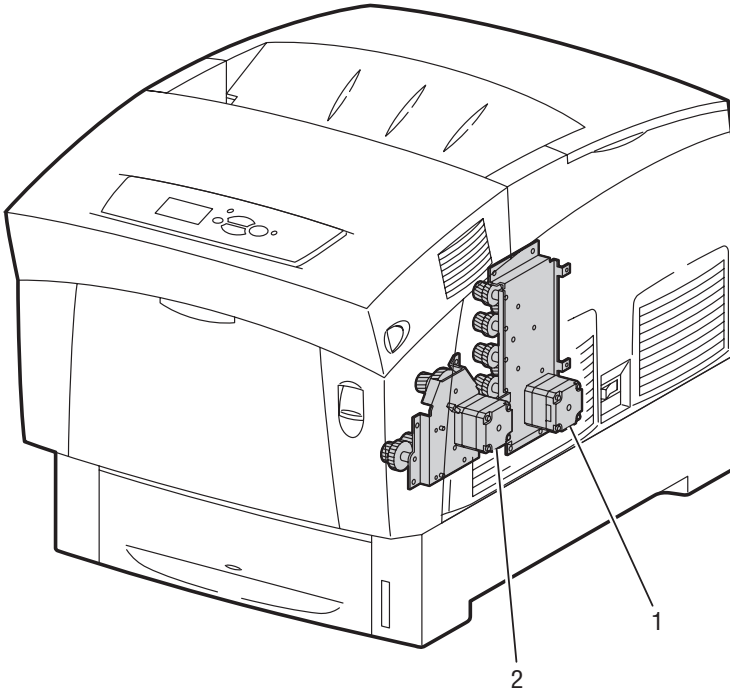

6250-064

- 1. Developer Drive Assembly:** Supplies the drive to the Imaging Unit Developer.
- 2. Main Drive Assembly:** Supplies the drive to the following parts:
 - Paper Feeder
 - Retard Housing Assembly
 - Chute Assembly, Out (MPT position)
 - Chute Assembly, Registration
 - Imaging Unit (IDT 1, IDT 2, Drum)
 - Transfer Roller

Main Drive Assembly - Transmission Route

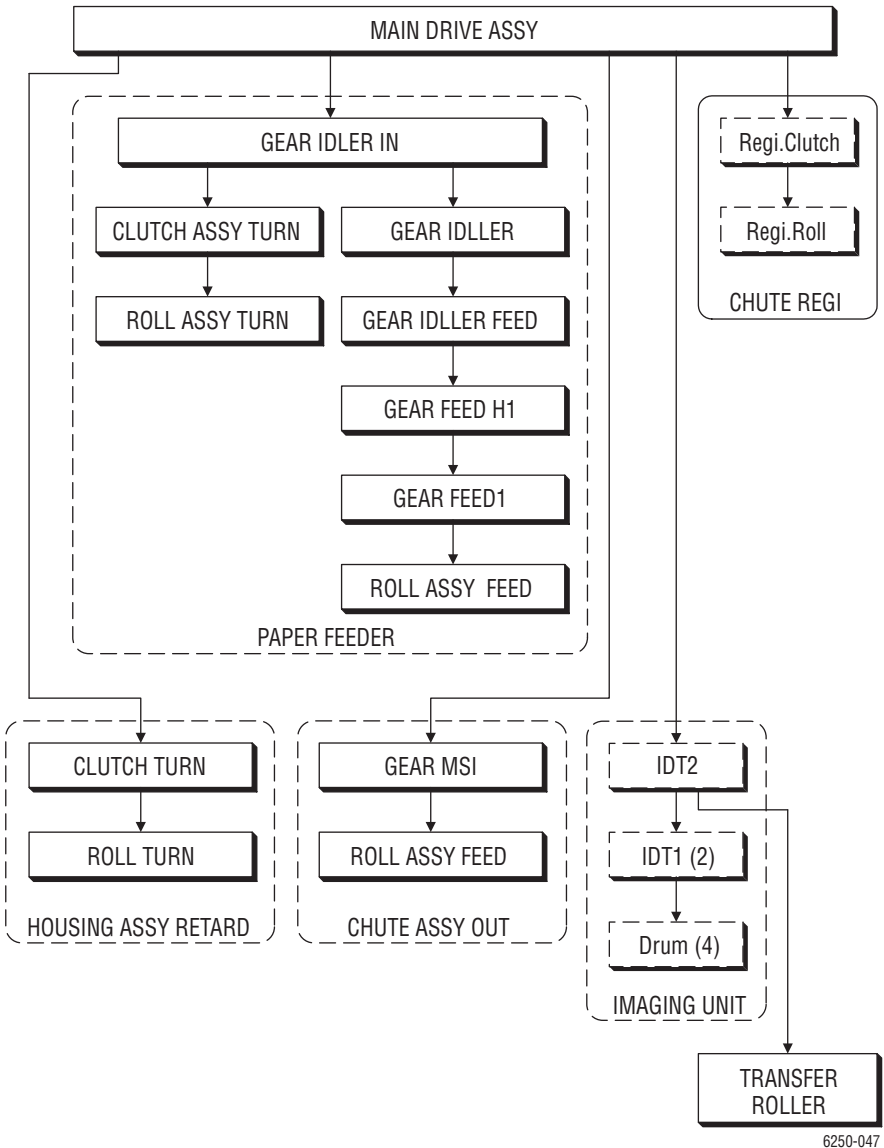

6250-047

Gear Layout - Print Engine and Tray 1

The drawing below shows the location of the various components specified in the Transmission Route Block Diagram on the preceding page.

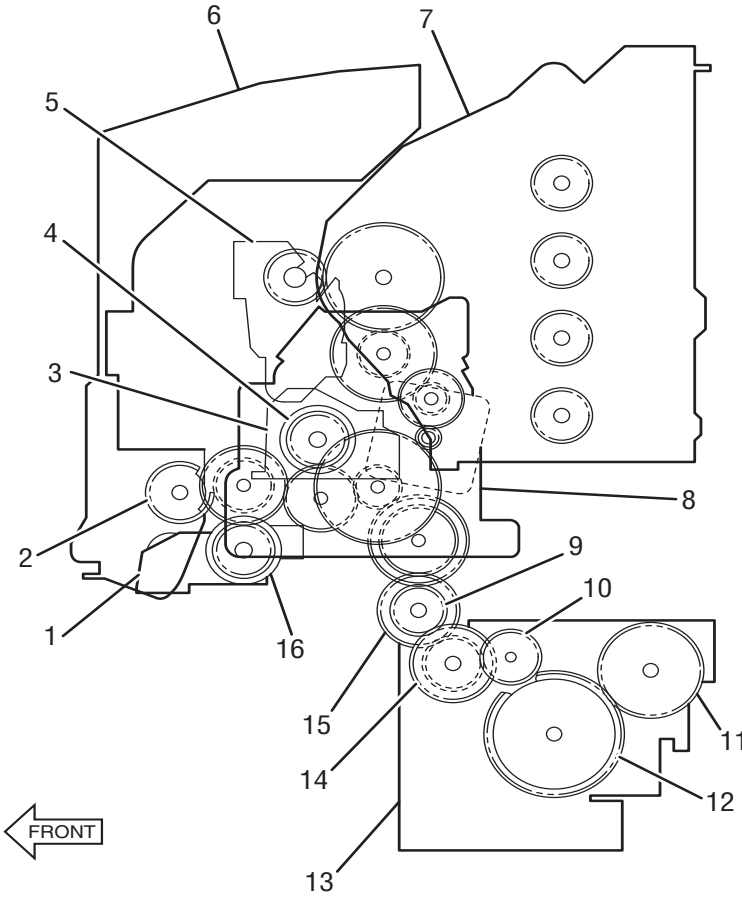

6250-052

- | | |
|---------------------------------------|---------------------------------------|
| 1. Retard Housing | 9. Turn Clutch Assembly |
| 2. Tray 1 Gear | 10. Gear Idler Feed |
| 3. Registration Chute Assembly | 11. Gear Feed 1 |
| 4. Registration Clutch | 12. Gear Feed H1 |
| 5. Transfer Roller | 13. Paper Pick Assembly (Tray) |
| 6. Chute Assembly Out | 14. Gear Idler |
| 7. Imaging Unit | 15. Gear Idler In |
| 8. Main Drive Assembly | 16. Turn Clutch |

Paper Tray 2

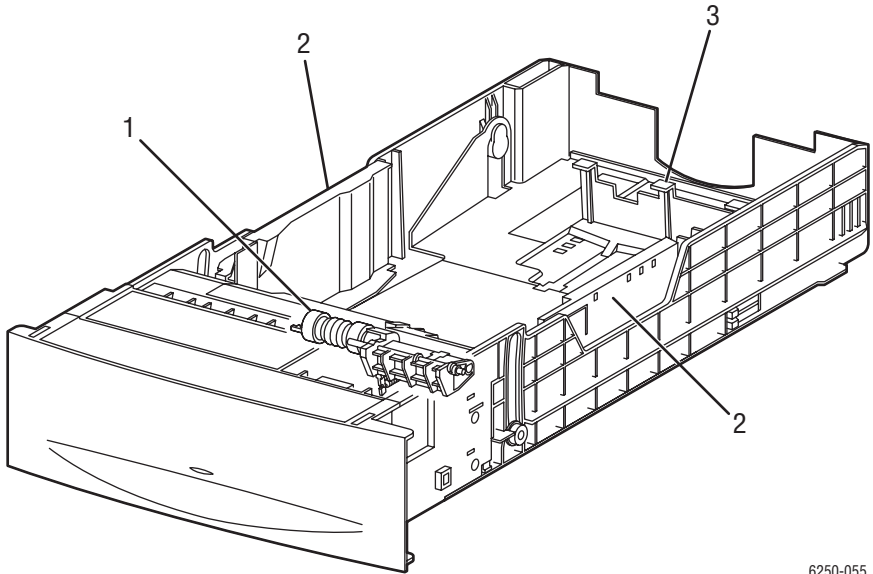

6250-055

- 1. Paper (Retard) Feed Roller:** The paper retard feed roller prevents more than 1 sheet at a time from printing. The paper feed *retard* roller and the paper feed *nudge* roller are interchangeable parts in all trays.
- 2. Side Guides Right and Left:** The side guides move against media to align or register the width of print media in the paper feed direction.
- 3. Rear Guide:** The rear guide moves to determine the length of print media in the paper feed direction. The paper size switch uses this rear guide to detect the paper size.

Paper Feed - Tray 2

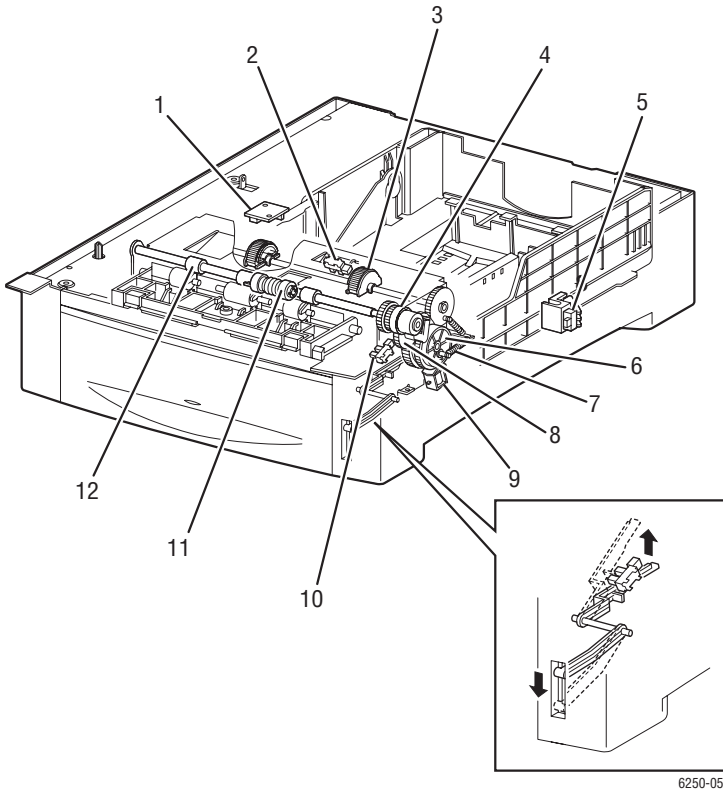

6250-056

- 1. Temperature/Humidity Sensor:** Detects temperature and humidity inside the printer to adjust the charge voltage (the voltage supplied to the transfer roller and the developing bias).
- 2. No Paper Sensor:** Detects presence or absence of print media in the tray based on the position of the Actuator.
- 3. Paper Pick Rollers:** When the feed solenoid energizes, the spring feed force engages the gear feed and the gear idler feed to turn and feed the paper from the paper tray. This activates the pick-up assembly. After completion of one turn, determined by a cutout in the gear feed, the gear feed and the gear idler feed are disengaged stopping the paper retard feed roller. This allows one sheet to be fed at a time.
- 4. Turn Clutch Assembly:** Transfers the drive energy from the main drive assembly to the roll turn assembly.
- 5. Paper Size Switch:** Detects print media size and installation of the paper tray.
- 6. Gear Feed:** See Paper Pick Rollers.
- 7. Spring Feed:** See Paper Pick Rollers.

- 8. Gear Idler Feed:** See Paper Pick Rollers.
- 9. Feed Solenoid:** Controls the operation (rotation/stop) of the Feed Roller Assembly by controlling the rotations of the Gear Feed.
- 10. Low Paper Sensor:** The actuator lowers as print media is used in the tray. When the actuator lowers to a pre-determined position, it blocks the sensor beam to trigger a low paper status. The actuator position can be seen from the front of the paper tray allowing confirmation of the print media quantity.
- 11. Paper Feed Roll:** See paper Pick Rollers.
- 12. Roll Turn Assembly:** The roll turn assembly receives drive energy from the main drive through the turn clutch and transports the print media out of the paper tray to the registration roller.

High-Capacity Feeder Trays 3 and 4

Note

The callouts in the following figure refer to the identifying numbers in the preceding paragraphs. The T3 and T4 in the callouts identify the tray. Tray 2 paper pick assembly has a different part number than the HCF Tray 3 and Tray 4 paper pick assembly.

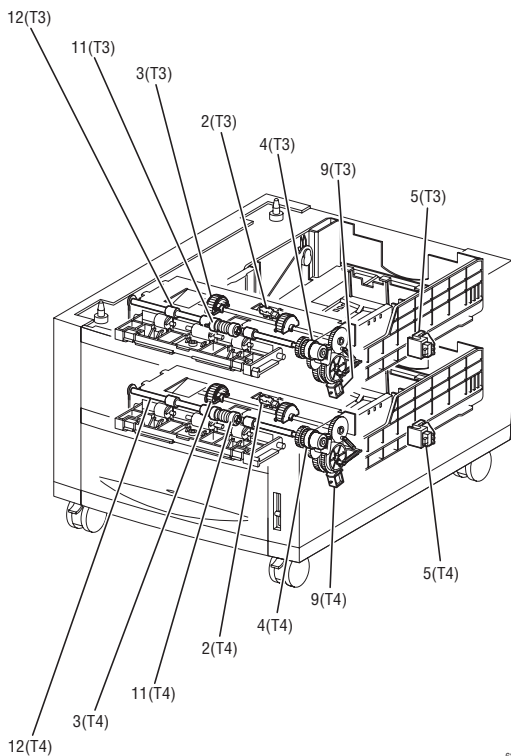

6250-446

500-Sheet Feeder Tray 3

Note

Tray 2 paper pick assembly has a different part number than the 500-Sheet Feeder, Tray 3 paper pick assembly.

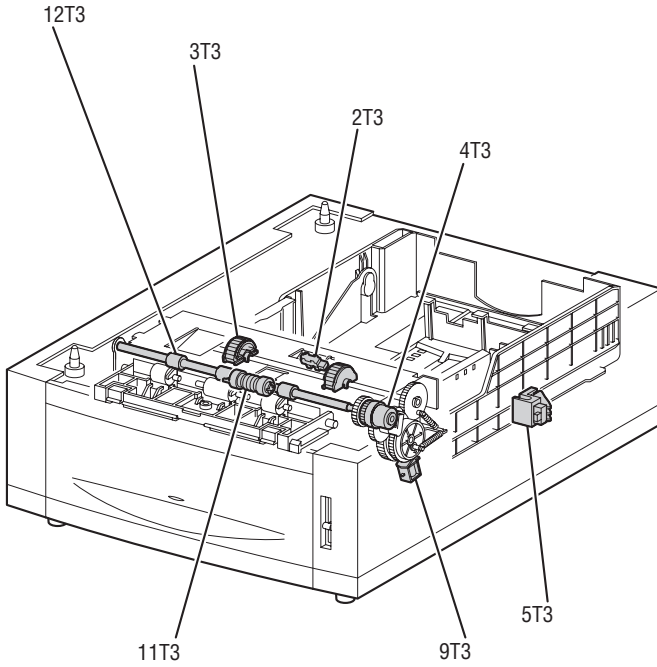

6250-405

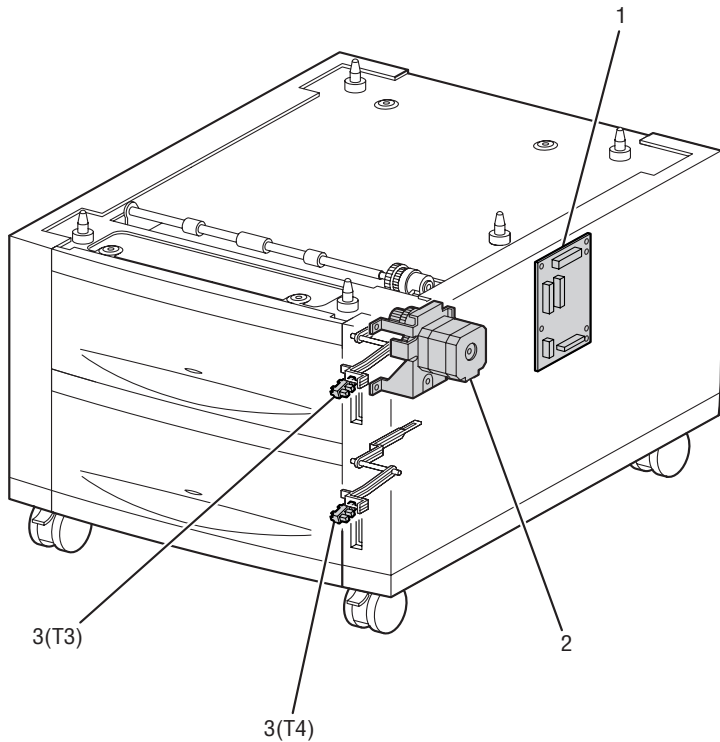

6250-447

1. HCF Feeder Circuit Board: Controls the paper pick-up operation of each tray based on communication with the Engine Control Board and information from the sensors and switches.

Major Functions:

- Communicates with the Engine Control Board.
- Receives information transmitted from the sensors and switches.
- Controls the Feeder Drive Assembly.
- Controls the paper pick process.
- Distributes the DC voltage power supplied from the print engine to each component.

2. Feeder Drive Assembly: Supplies the drive to the Tray 3 and 4.

3. Low Paper Sensor: The actuator lowers as print media is used in the tray. When the actuator lowers to a pre-determined position, it blocks the sensor beam to trigger a low paper status. The actuator position can be seen from the front of the HCF allowing confirmation of the print media quantity.

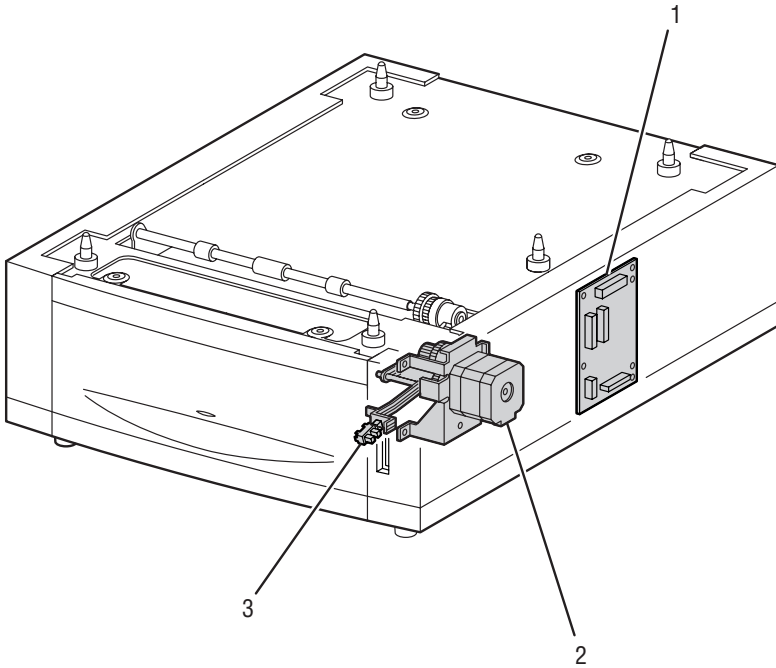

6250-406

1. 500-Sheet Feeder Circuit Board: Controls the paper pick-up operation of tray 3 based on communication with the Engine Control Board and information from the sensors and switches.

Major Functions:

- Communicates with the Engine Control Board.
- Receives information transmitted from the sensors and switches.
- Controls the Feeder Drive Assembly.
- Controls the paper pick process.
- Distributes the DC voltage power supplied from the print engine to each component.

2. Feeder Drive Assembly: Supplies the drive to the tray 3.

3. Low Paper Sensor: The actuator lowers as print media is used in the tray. When the actuator lowers to a pre-determined position, it blocks the sensor beam to trigger a low paper status. The actuator position can be seen from the front of the 500-Sheet Feeder allowing confirmation of the print media quantity.

HCF Drive and Gears - Transmission Route

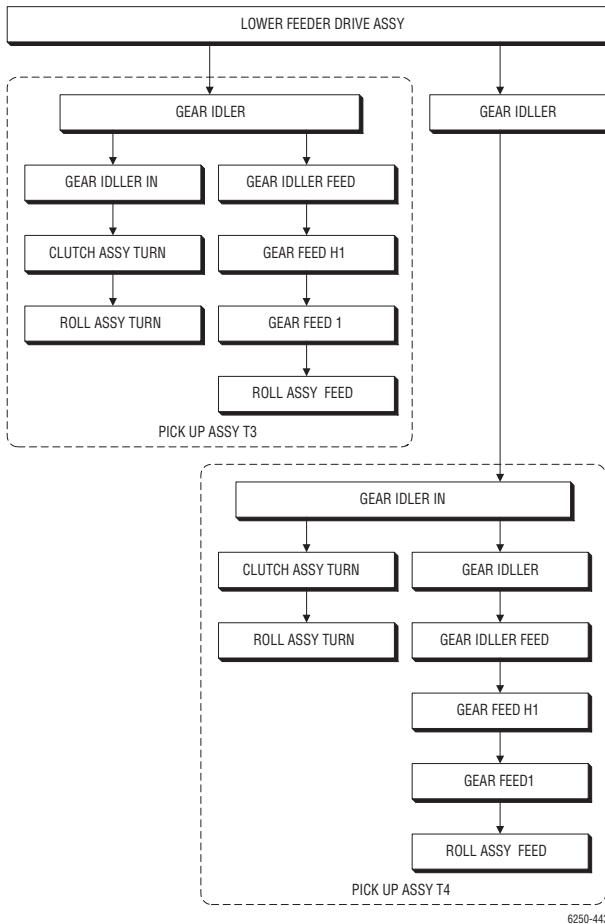
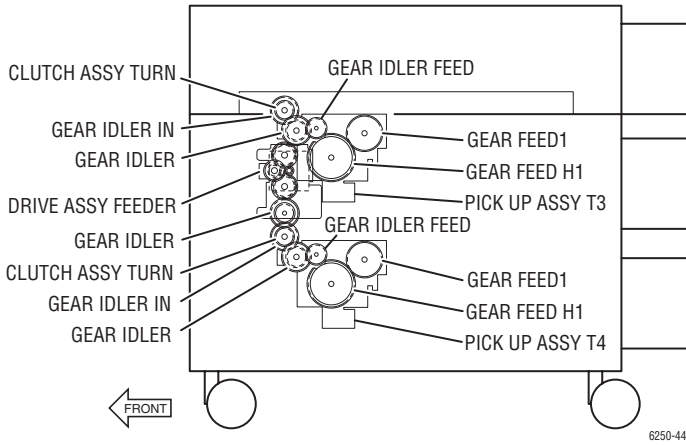

500-Sheet Feeder Drive and Gears - Transmission Route

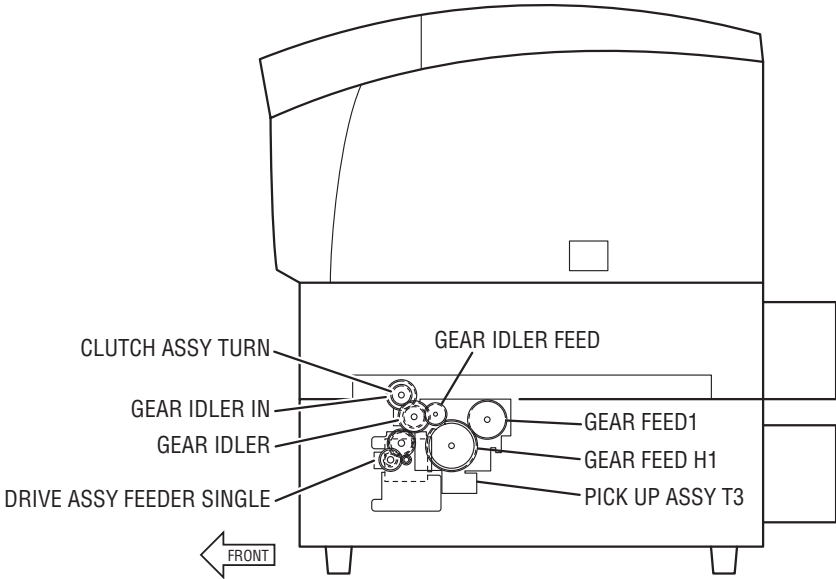

6250-404

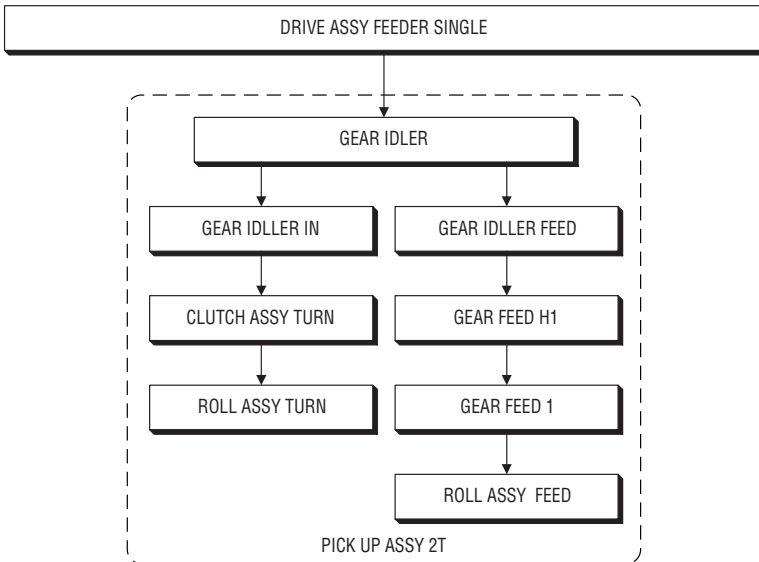

6250-403

Retard Housing Assembly

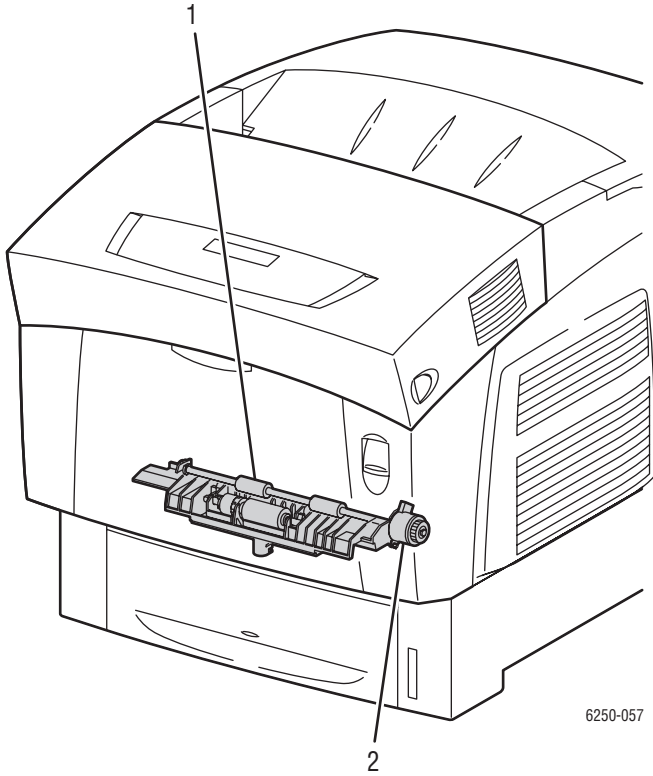

- 1. Roll Turn:** The roll turn is rotated by the main drive assembly, through the turn clutch to feed paper from Tray 1 to the registration chute, (Registration Roll - See “Xerographics” on page 2-35.).
- 2. Turn Clutch:** Transfers drive energy from the main drive assembly to the roll turn through a friction clutch.

Chute Assembly In

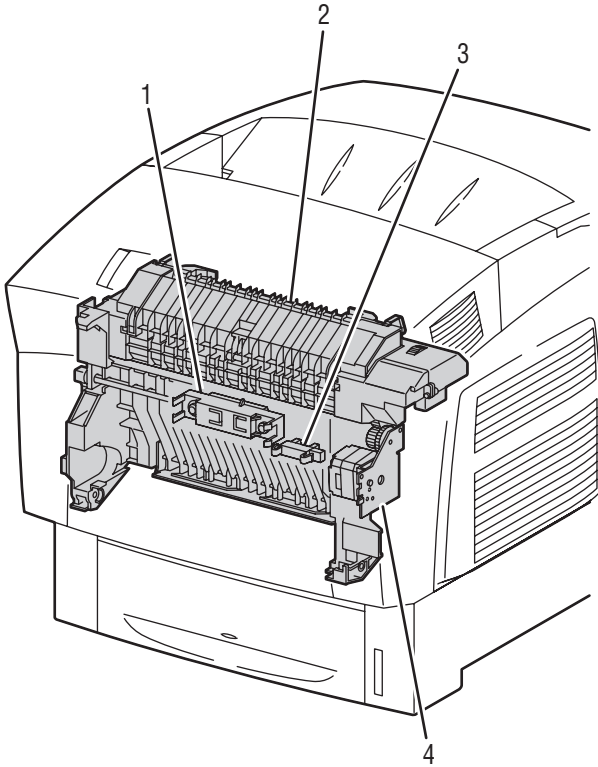

6250-058

- 1. CTD (ADC) Sensor:** Detects the presence of the Transfer Roller and monitors the density of toner on the surface of the transfer roller then feeds it back to the process control.
- 2. Fuser Assembly:** See “Transfer Roller and Fuser Assembly” on page 2-33.
- 3. Waste Toner Full Sensor:** Detects when the waste toner collect space in the transfer roller assembly is full.
- 4. Fuser Drive Assembly:** Supplies the drive to the Fuser Assembly.

Chute Assembly Out

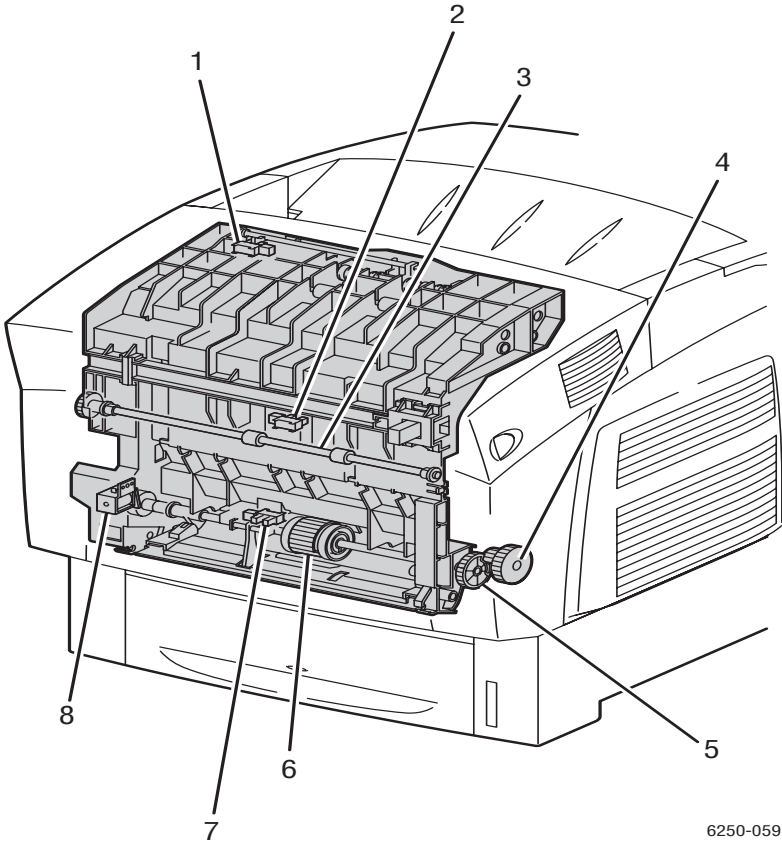

6250-059

- 1. Full Stack (Output Tray Full) Sensor:** Detects a full output tray (over accumulation of print media) by the position of the actuator. This is only checked when the paper is feeding into the exit.
- 2. Duplex Jam Sensor:** Detects when print media has reached and passed through the duplex roller based on the position of the actuator.
- 3. Duplex Roller:** The duplex roller rotates under drive from the duplex motor and feeds the print media returned from the chute assembly exit to the roll turn in the retard housing assembly.
- 4. Gear (Main Drive):** See Feed Roll Assembly.
- 5. Tray 1 Gear:** See Feed Roll Assembly.
- 6. Feed Roll Assembly:** When the Tray 1 feed solenoid energizes, the Tray 1 gear and the idler gear are engaged by the force of the spring solenoid. The feed roll rotates from the drive of the Main Drive Assembly and feeds paper from

Tray 1. After rotating one turn, the Tray 1 gear and the gear idler are disengaged, the drives and feed roll stop, allowing only one sheet of paper to be fed through at a time.

7. **Tray1 No Paper Sensor:** Actuator detects whether print media is present. No paper sensor beam is interrupted.
8. **Tray1 Feed Solenoid:** Controls the operation (rotation/stop) of the Feed Roll Assembly by controlling the rotations of the Tray 1 Gear.

Chute Assembly Exit

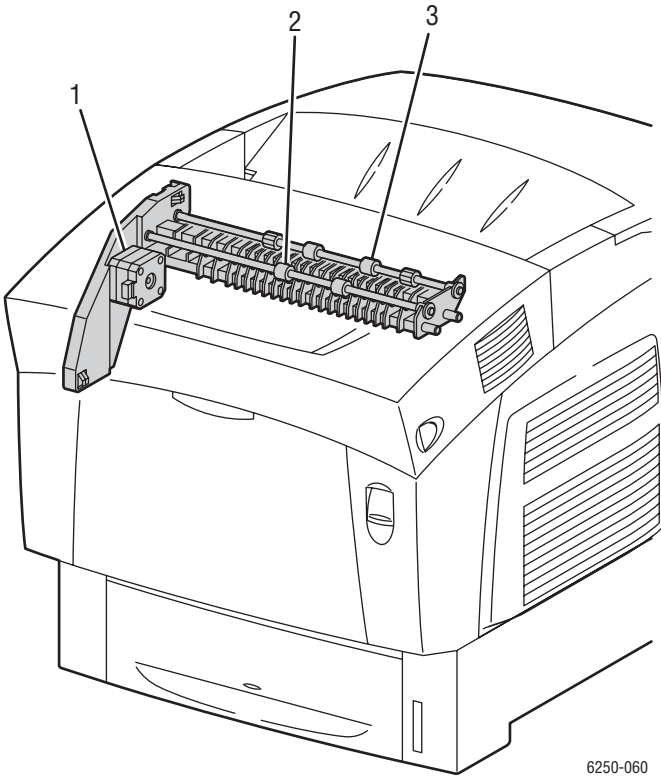

1. **Duplex Motor:** Supplies the drive to the exit roller, mid roller, and duplex roller.
2. **Mid Roller:** See Exit Roller.
3. **Exit Roller:** Rotates through the drive from the Duplex Motor and drives the fused print media partially into the output tray where it then reverses in duplex mode and feeds the print media (fused on one side) in the direction of the Registration Chute.

Duplex Motor Drive and Gear - Transmission Route

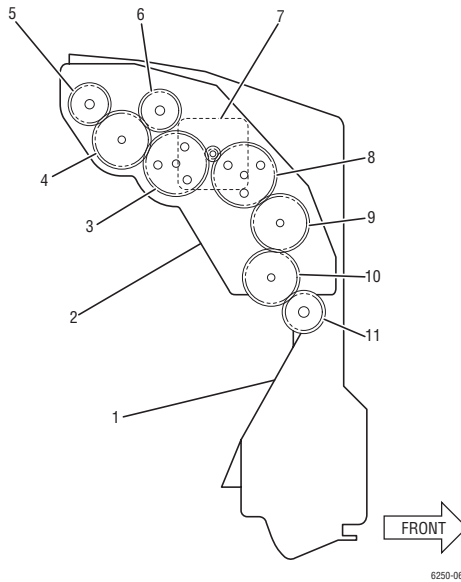
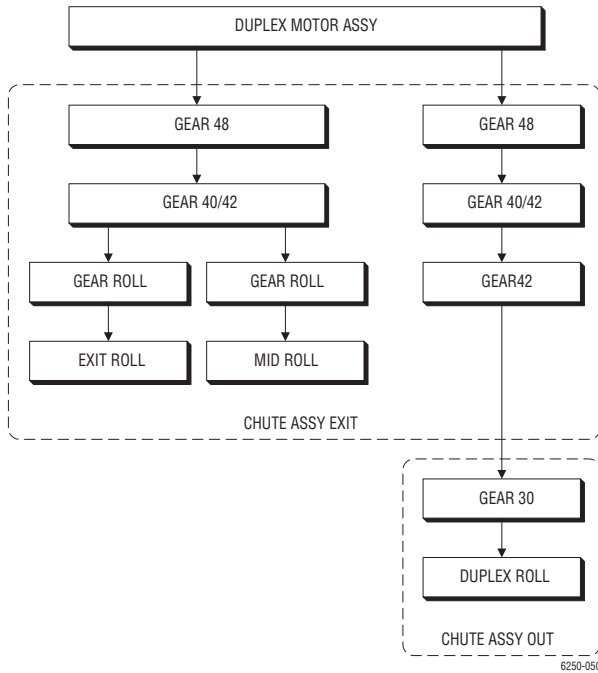

- | | | | |
|--------------------|---------------|-----------------|-------------|
| 1. Chute Assy Out | 4. Gear 40/42 | 7. Motor Duplex | 10. Gear 42 |
| 2. Chute Assy Exit | 5. Gear Roll | 8. Gear 48 | 11. Gear 30 |
| 3. Gear 48 | 6. Gear Roll | 9. Gear 40/42 | |

Chute Assembly Registration (REGI)

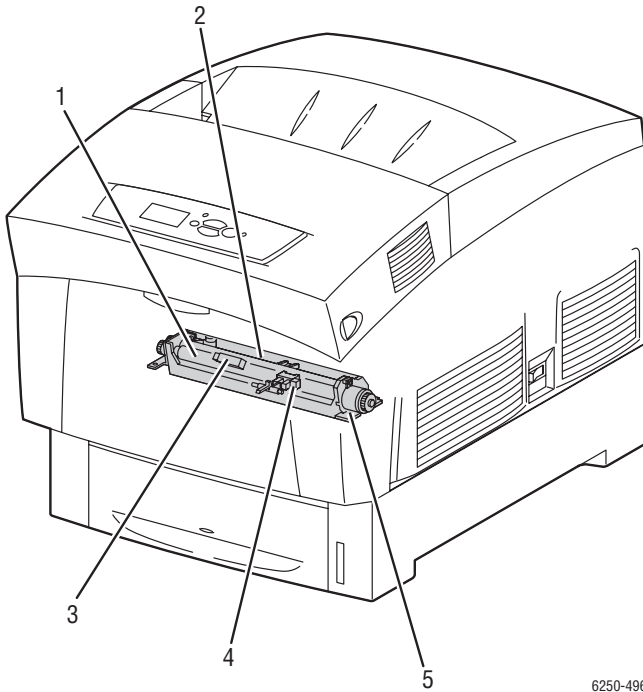

6250-496

- 1. Registration Roller (Rubber):** Receives drive energy from the main drive assembly through the registration clutch. Works with the registration metal roller to correct media skew and transport the media from paper tray 1 or 2.
- 2. Registration Roller (Metal):** Works in conjunction with the rubber roller. When the leading edge of the paper arrives at the registration rubber roller/metal roller, the rollers are not turning and the paper buckles against the rollers to correct any skew at the leading edge.
- 3. OHP (Transparency) Sensor:** Paper reflects radiated light and the OHP sensor can sense reflected light and identify the print media as paper. If the OHP sensor cannot sense reflected light, it identifies the print media as OHP (transparency).
- 4. Registration Sensor:** Detects the when the print media leading edge has reached the Registration Chute.
- 5. Registration Clutch:** Transmits the drive from the main drive assembly to the registration rollers once media skew has been corrected.

Transfer Roller and Fuser Assembly

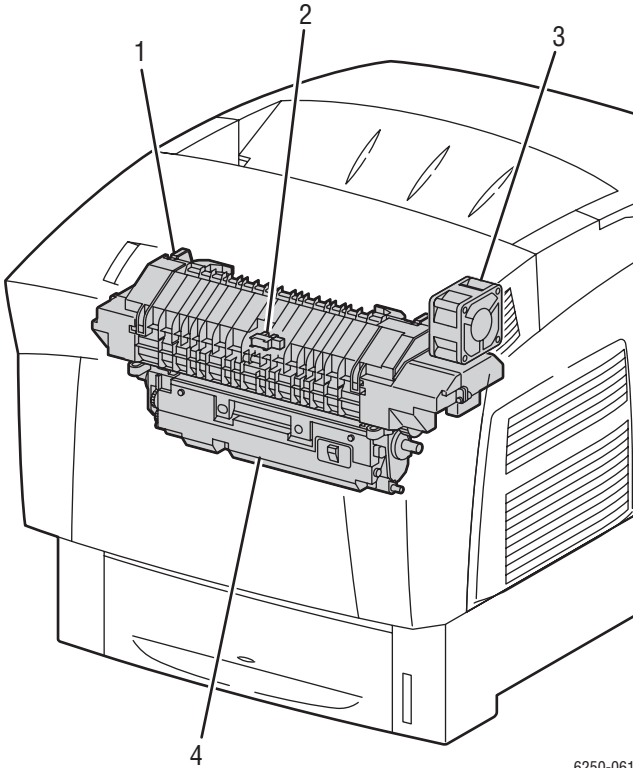

6250-061

1. Fuser Assembly: Using heat and pressure, the fuser assembly fixes the transferred toner onto print media.

Parts of the Fuser Assembly:

- Heat Roll
- Thermostat
- Belt Unit
- Exit Sensor
- Heat Lamp
- Temperature Sensor
- Exit Roll Assembly
- CRUM

2. Exit Sensor: Detects passage of the print media after fusing.

3. Fuser Fan: Cools the fuser assembly to prevent overheating.

4. Transfer Roller: Consists of the transfer roller and a waste toner recovery system. The transfer roller transfers the image from IDT2 in the imaging unit onto the print media.

Fuser Drive Assembly - Transmission Route

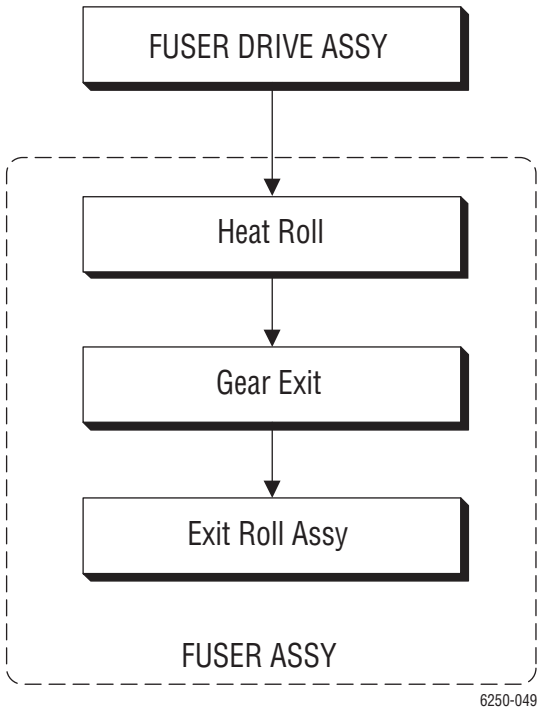

Xerographics

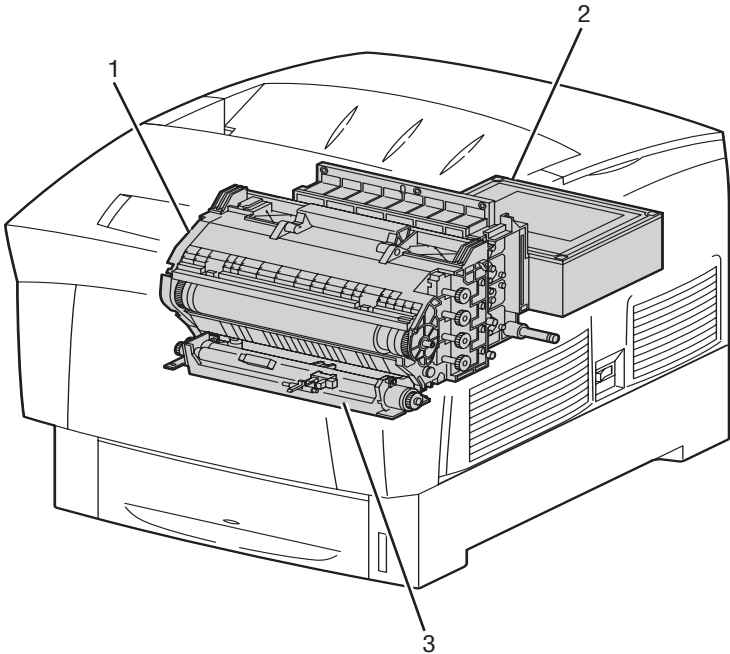

6250-062

1. Imaging Unit: The Imaging Unit carries out the operations of the printing process, such as charging, developing, and primary transfer. The Imaging Unit consists of the following parts:

- Drum (Y M C K)
- Charge Roller (Y M C K)
- IDT1 (2)
- IDT1 Cleaner (2)
- Developer (Y M C K)
- Refresher (Y M C K)
- IDT2
- IDT2 Cleaner

2. Laser Unit: The Laser Unit receives image data and generates laser beams to form an electrostatic latent image on the surface of each of the four imaging unit drums. The Laser Unit Assembly consists of the following parts:

LD Assembly
SOS Board
Mirror

Scanner Assembly
Lens
Window

3. Chute Assembly Registration: See “Chute Assembly Registration (REGI)” on page 2-32.

Imaging Unit Charge Voltage Contacts

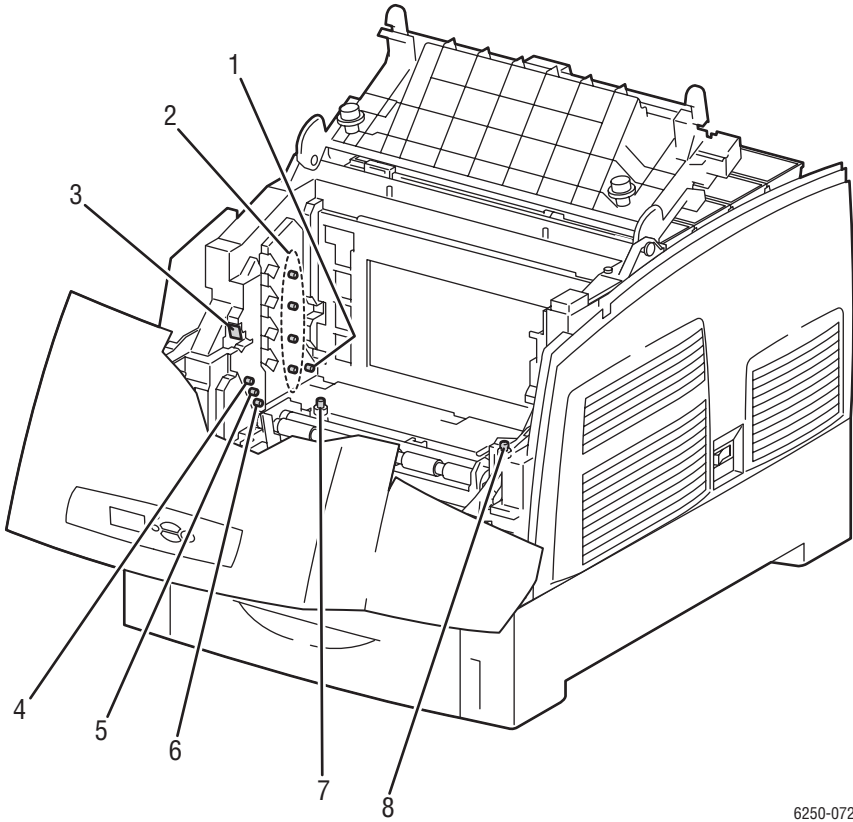

6250-072

1. Charge Voltage
2. Developer Voltage
3. IDT2 Voltage
4. IDT2 Refresher/Cleaner
5. IDT1 Voltage
6. IDT1 Refresher/Cleaner
7. Drum Refresher/Cleaner
8. Drum Ground Contacts

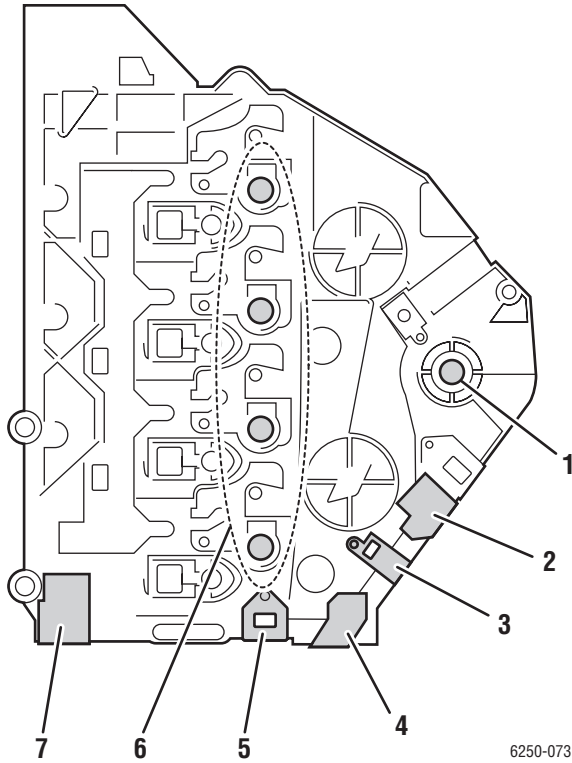

Imaging Unit - Left Side View

1. IDT2
2. IDT2 Refresher/Cleaner
3. IDT1
4. IDT1 Refresher/Cleaner
5. Drum Refresher/Cleaner
6. Developer
7. Charge Roller

Toner Cartridge Assembly

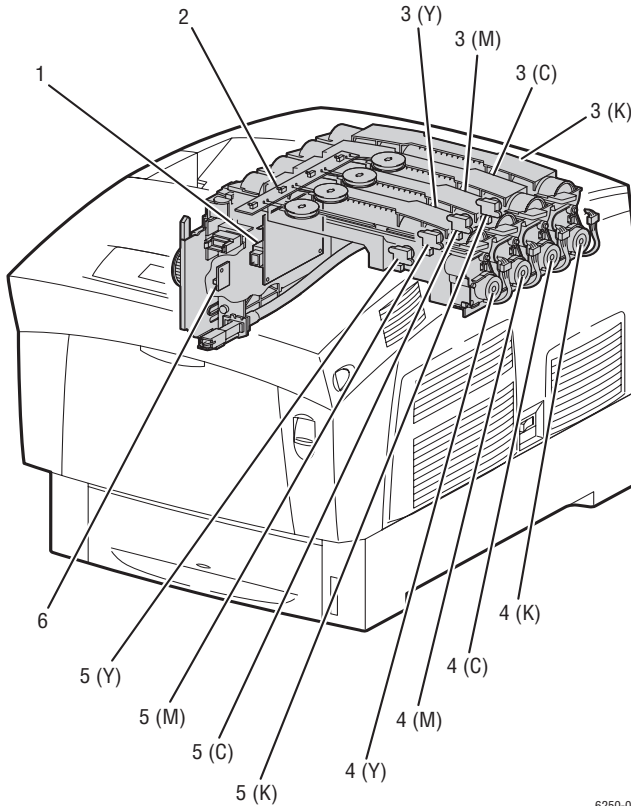

6250-063

- 1. Sub-High Voltage Power Supply Board:** Supplies high-voltage to the Transfer Roller and the Detack Saw for the ‘tertiary transfer’ and ‘static elimination’ part of the printing process.
- 2. CRUM Reader:** The Customer Replaceable Unit Monitor (CRUM) detects toner usage and provides a front panel monitor of remaining levels for each color.
- 3. Toner Cartridge [Y] [M] [C] [K]:** Individual toner bottles containing toner mixture.
- 4. Toner Cartridge Holder Assembly and Toner Motors [Y] [M] [C] [K]:** The Toner Cartridge Holder Assemblies each contain a toner motor which supplies the drive to the Agitator in the Toner Cartridges and to the Auger in the Toner Cartridge Holder, supplying toner to the developer in the Imaging Unit.
- 5. Low Toner Sensor [Y] [M] [C] [K]:** Detects level of toner in each auger tube.
- 6. Circuit Board, EEPROM:** Consumable use (Fuser and Imaging Unit NVRAM Data) information is stored and communicated to the Engine Control Board.

Toner Cartridge Assembly - cont'd

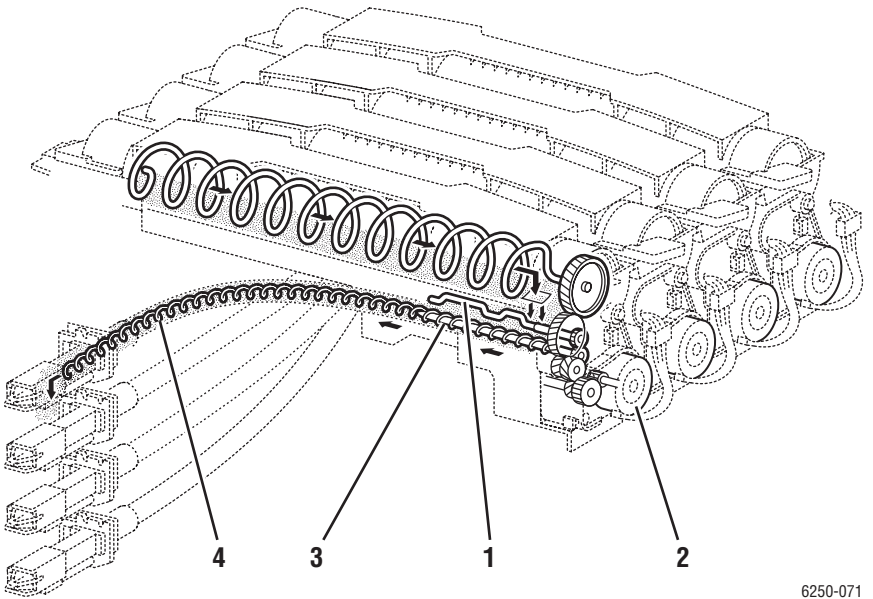

6250-071

- 1. Agitator Assembly
- 2. Toner Motor
- 3. Auger Assembly
- 4. Auger Tube

Toner Motor Drive Assembly - Transmission Route

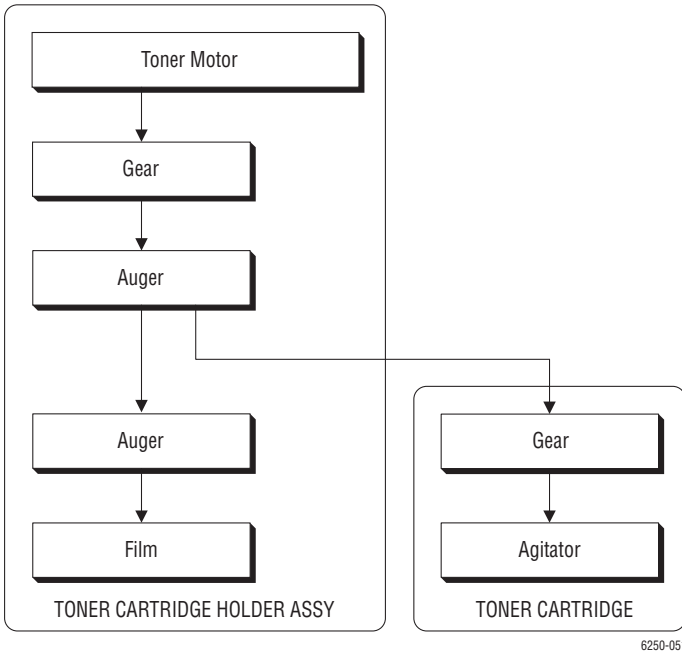

Developer Assembly Transmission Route

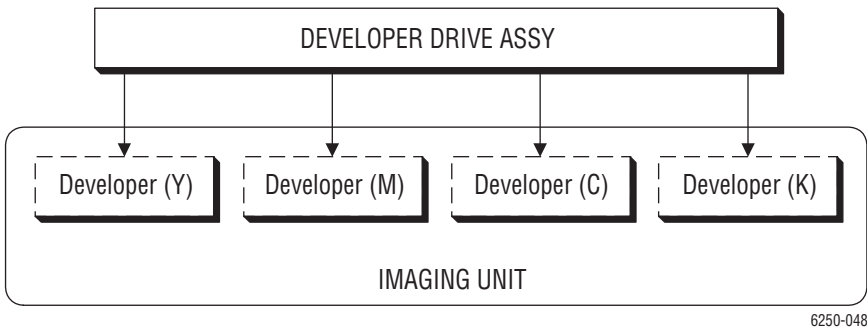

Electrical

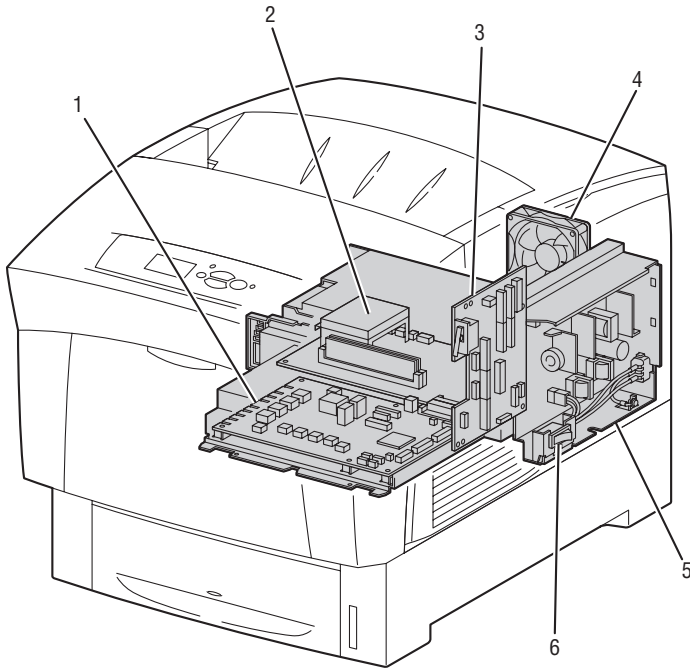

6250-065

1. Engine Control Board: Controls printing operation based on the communication with the Image Processor Board and input from the sensors and switches. Incorporates functions of the High-Voltage Power Supply.

Major Functions:

- Communicates with the Image Processor Board
- Receives information from the sensors and/or switches.
- Controls the Laser Unit.
- Supplies high-voltage to the Imaging Unit to perform charging, development, primary transfer and secondary transfer

2. Image Processor Board: Receives data from the workstation or host, rasterizes the data and passes it on to the Engine Control Board. The microprocessors on the Image Processor Board, generate the control signals used by the Engine Control Board. The system NVRAM chip is also located on this board and stores several printer parameters.

3. Motor Driver Board: Controls motors through the signals received from the Engine Control Board and sends information from the sensors and switches to the Engine Control Board. Power from the low-voltage power supply is supplied to the Engine Control Board through the Motor Driver Board. The interlock switch is mounted on the Motor Driver Board.

Major Functions:

- Receives information from the sensors and switches.
 - Controls the motor in the Main Drive Assembly, Developer Drive Assembly, Fuser Drive Assembly, Duplex Motor Assembly and the Holder Toner Cartridge Motor Assembly.
 - Distributes the low-voltage DC power from the Low-Voltage Power Supply.
 - Controls the 24 VDC circuit through the interlock switch.
4. **Rear Fan:** Removes heat from the printer to prevent over-heating.
5. **Low-Voltage Power Supply Board:** Supplies AC power from the power source to the Fuser Assembly heater. Generates and supplies stable low-voltage DC power (+3.3 VDC, +5 VDC, and +24 VDC) to be used for the logic and other circuits within the printer.
6. **AC Switch Harness Assembly:** Consists of the main switch and harness. Controls the supply of AC power from the power source to the Low-Voltage Power Supply.

Error Messages and Codes

In this chapter...

- Introduction
- Servicing Instructions
- Service Diagnostics
- Error Messages and Codes Troubleshooting Procedures Table

Chapter 3



Introduction

This section provides troubleshooting information related to the Phaser 6250 Color Laser Printer's front panel error messages and codes. Only jams and fatal errors will produce an associated numeric code. Error messages and codes are generally specific, making it important that service personnel and users record error messages as displayed, and provide that information when reporting problems with the printer. Any code associated with an error message or jam can be viewed by pressing the **INFO** button and scrolling to the bottom of the help text displayed on the front panel.

Some procedures require running service diagnostic test functions to verify a specific printer part is operating correctly. For information on Service Diagnostics and all internal printer test functions, see the table "Service Diagnostics" on page 3-9

To troubleshoot problems, such as start up and power on, media, paper path, print-quality or image problems, and electrical failures not associated with a front panel message or code, refer to the section "Troubleshooting" on page 4-1.

If an error message or code is not visible on the front panel, the usage profile report and fault history list errors reported by the printer.

Jam error histories have a slightly different format than other error codes. The correlation between the Jam Error Help Text and the equivalent Fault History Code is given in the "Jam History Error Codes Table" on page 3-16

When an error first occurs, record the error message and code then cycle power to the printer to see if the error recurs. These can be accessed one of three ways:

Accessing Fault History

1. Print (if possible) the **Printer Status Page** from the printer's front panel **Troubleshooting Menu --> Service Tools**. The fault history is listed on the second page of the report.
2. View the printer's fault history on the front panel. Go to **Troubleshooting Menu --> Service Tools --> Engine Error History**.

Note

Definitions of the fault codes that appear in the fault history are given in "Printer Status Codes" on page A-2.

3. If the printer is connected to a network and has a TCP/IP address, view the printer's web page using a web browser.
 - a. Open a web browser.
 - b. Enter the printer's IP address as the URL.
 - c. Select the Support Tab/Troubleshooting/Diagnostics Logs and the fault history will be displayed.
4. If additional information is required, print the **Service Usage Profile** from the printer's front panel **Troubleshooting Menu --> Service Tools**.

Servicing Instructions

The Service Flowchart below is an overview of the path a service technician should take when servicing the printer and printer optional equipment.

Step 1 - Identify the Problem

1. Verify the reported problem does exist. Verify failure symptoms/behavior/noises with customer/end user.
2. Check for any error codes and write them down.
3. Print normal customer prints and service test prints.
4. Make note of any print quality problems in the test prints.
5. Make note of any mechanical or electrical abnormalities present.
6. Make note of any unusual noise or smell coming from the printer.
7. Print a Printer Status Page, if the printer is able to print.
8. View the fault history under the Service Tools Menu
9. Verify the AC input power supply is within proper specifications by measuring the voltage at the electric outlet while the printer is running.

Step 2 - Inspect and Clean the Printer

1. Switch OFF printer power.
2. Disconnect the AC power cord from the wall outlet.
3. Verify the power cord is free from damage and is connected properly.
4. Remove the Imaging Unit and protect it from light.
5. Inspect the printer interior and remove any foreign matter such as paper clips, staples, pieces of paper, dust or loose toner.
 - Do not use solvents or chemical cleaners to clean the printer interior.
 - Do not use any type of oil or lubricant on printer parts.
 - Use only an approved toner vacuum.
6. Clean all rubber rollers with a lint-free cloth, dampened slightly with cold water.
7. Inspect the interior of the printer for damaged wires, loose connections, toner leakage, and damaged or obviously worn parts.
8. If a toner cartridge appears obviously damaged or empty, replace with a new one.

Step 3 - Find the Cause of the Problem

1. Use the Error Messages and Codes troubleshooting procedures to find the cause of the problem.
2. Use Diagnostics to check printer and optional components.
3. Use the Wiring Diagrams and Plug/Jack Locator to locate test points.
4. Take voltage readings at various test points as instructed in the appropriate troubleshooting procedure.
5. Use the "Print Engine Test Print" on page 5-9, to isolate problems to the Engine or the Image Processor Board.

Step 4 - Correct the Problem

1. Use the Parts List to locate a part number.
2. Use the Disassembly Procedures to replace the part.

Step 5 - Final Check

1. Test the printer to be sure you have corrected the initial problem and verify there are no additional problems present.
-

Using the Troubleshooting Procedures

1. Each Step in a Troubleshooting Procedure instructs you to perform a certain action or procedure. The Steps are to be followed sequentially in the order given until the problem is fixed or resolved.
2. The Actions and Questions box contains additional information and/or additional procedures you must follow to isolate the problem.
3. When a procedure instructs you to test a component using service diagnostics, See "Service Diagnostics" on page 3-6 for the detailed Steps and functions for testing parts of the printer.
4. The action is followed by a question. If your response to the question is "Yes", then follow the instructions for a "Yes" reply. If your response to the question is "No", then follow the instructions for a "No" reply.
5. Troubleshooting Procedures may ask you to take voltage readings or test for continuity at certain test points within the printer. For detailed diagrams, refer to the section "Plug/Jack Locator Maps" on page 10-2 and "Wiring Diagrams" on page 10-12 for complete information on test point locations and signal names.
6. Troubleshooting Procedures often ask you to replace a printer component. The section "Service Parts Disassembly" on page 8-1 provides detailed Steps for removing and replacing all major parts of the printer. The section "Parts List" on page 9-1 details the location, quantity and part number for all spared parts of the printer.

General Notes on Troubleshooting

1. Unless indicated otherwise, the instruction "switch ON printer main power" means for you to switch ON printer power and let the printer proceed through Power On Self Test (POST) to a 'Ready' condition.
2. Conventions used in this manual to represent connectors



6250-503

3. When instructed to take voltage, continuity or resistance readings on wiring harness, proceed as follows; Check P/J 232–1 to P/J 210–5 by placing the red probe (+) of your meter on pin 1 of P/J 232, and place the black probe (–) of your meter on pin 5 of P/J 210.
4. When you are instructed to take resistance readings between "P/J 232 <=> P/J 210" (without specified pin numbers), check all pins. Refer to the the section "Wiring Diagrams" on page 10-1 for the location of all wiring harnesses and pins.
5. When you are instructed to take a voltage reading, the black probe (–) is generally connected to a pin that is either RTN (Return) or SG (Signal Ground). You can substitute any RTN pin or test point in the printer, and you can use FG (frame ground) in place of any SG pin or test point.

6. Before measuring voltages make sure the printer is switched ON, the Imaging Unit and the paper trays are in place, and the interlock switches are actuated, unless a troubleshooting procedure instructs otherwise.
7. All voltage values given in the troubleshooting procedures are approximate values. The main purpose of voltage readings is to determine whether or not a component is receiving the correct voltage value from the power supply and if gating (a voltage drop) occurs during component actuation. Gating signals may be nothing more than a pulse, resulting in a momentary drop in voltage that may be difficult or impossible to read on the average multi-meter.
8. When a troubleshooting procedure instructs you to replace a non-spared component and that component is part of a parent assembly, you should replace the entire parent assembly.
9. Ensure that you are using a supported media size and type, refer to "Media and Tray Specifications" on page 1-14.

Voltage Measurements

1. Power and signal grounds are connected to the frame ground. All circuit troubleshooting can be performed using the metal frame (chassis) as the grounding point. To locate connectors or test points, refer to the section "Plug/Jack Locator Maps" on page 10-2 or "Wiring Diagrams" on page 10-12 for more information.

Unless otherwise specified, the following voltage tolerances are used within this section:

Stated	Measured
+3.3 VDC	+3.135 to +3.465 VDC
+5.0 VDC	+4.75 to +5.25 VDC
+24.0 VDC	+21.6 to +26.4 VDC
0.0 VDC	Less than +0.5 VDC

Service Diagnostics

The Phaser 6250 Color Laser Printer has built-in diagnostics to aid in troubleshooting problems with the printer. The Service Diagnostics Menu provides a means to test sensors, motors, switches, clutches, fans and solenoids. Diagnostics also contain built-in test prints, cleaning procedures, printer status and some NVRAM access.

Service diagnostics are executed through the front panel by a certified service technician only. Service Diagnostics can be entered one of two ways:

Entering without rebooting the printer:

1. From the printer's main menu, scroll to the **Troubleshooting Menu**, press **OK** and then scroll to the **Service Tools Menu** and press **OK**.
2. Hold down the **Up Arrow** button and press the **Down Arrow** button, this will display the **Hidden Service Menu**. Scroll to **Run Service Diagnostics** and press **OK**.

Entering by rebooting the printer:

1. Turn the printer power OFF.
2. Hold down the **Back** and **Information** buttons simultaneously and turn the printer back ON.
3. Continue to hold the buttons until the following message is displayed on the front panel: **Service Diagnostics V#.#, Initializing...**, and then release the buttons.
4. The front panel displays the **Service Diagnostics Menu**.

You can print a Service Diagnostics Menu Map by highlighting **Print Service Menu Map**, and press **OK**. The printer will run through POST and return to **Ready**. You will need to re-enter service diagnostics.

Service Diagnostic Front Panel Button Descriptions

Button	Function
BACK	Returns to the prior higher level menu structure, if available. If help text is displayed on the front panel, pressing BACK will restore the current menu item and remove the help text.
CANCEL	Terminates the current test. Cancels current INFO display.
INFO	Provides help information, if available. Pressing INFO again restores the current menu item and removes the help text.
UP	Scrolls up one menu item within a menu list. This control does not 'wrap'. Used to increment data in tests requiring user input.
DOWN	Scrolls down one menu item within a menu list. This control does not 'wrap', the end of a menu list is designated by three asterisks. Used to decrement data in tests requiring user input.
OK	Enters the highlighted menu. Executes the current test item. Used to select a data value entered by the user.

Diagnostic Menu Map

Phaser® 6250 Service Diagnostic Menu Map

Print Service Menu Map Prints a service diagnostic menu map and exits service diagnostics.

General Status Provides the following print engine status.

- Status
- Engine Board ROM Version
- Printer Configuration
- Ambient Temp/Humidity
- Fuser Temperature
- Fault History

Test Prints Prints Test Prints stored in the MCU. The prints are used by service personnel to identify, repair, and validate the operability of the printer.

- Blank Page Print
- Standard Test Print
- Custom Test Print
- Current Custom Test Print Set-up
- Custom Test Print Parameters

Motors/Fans Tests Tests the functionality of motors and fans by giving service personnel the ability to energize/de-energize the motor and fans one at a time.

- Main Motor
- Duplex Motor
- Fuser Motor
- Developer Motor
- HCF/LTA Motor
- Toner Motor Yellow
- Toner Motor Magenta
- Toner Motor Cyan
- Toner Motor Black
- Rear Fan
- Fuser Fan

Sensor/Switch Tests Test the functionality of sensors and switches by giving service personnel the ability to input actuation and state changes of all sensors and switches.

- Interlock Switch
- Registration Sensor
- Exit Sensor
- Duplex Sensor
- Full Stack Sensor
- Black Toner (K) Low/Empty Sensor
- Cyan Toner (C) Low/Empty Sensor
- Magenta Toner (M) Low/Empty Sensor
- Yellow Toner (Y) Low/Empty Sensor
- Black Toner Cart Present Switch
- Cyan Toner Cart Present Switch
- Magenta Toner Cart Present Switch
- Yellow Toner Cart Present Switch
- Black Toner CRUM Sensor
- Cyan Toner CRUM Sensor
- Magenta Toner CRUM Sensor
- Yellow Toner CRUM Sensor
- Tray 2 Low Paper Sensor
- Tray 3 Low Paper Sensor
- Tray 4 Low Paper Sensor

Sensor/Switch Tests -cont'd-

- Tray 1 (MPT) No Paper Sensor
- Tray 2 No Paper Sensor
- Tray 3 No Paper Sensor
- Tray 4 No Paper Sensor
- Transfer Roller Toner Full Sensor
- Image Unit Installed/Not Installed
- Fuser Fan Alarm Sensor
- Rear Fan Alarm Sensor
- ADC (CTD) Sensor
- OHP Sensor
- Fuser Center Temp Sensor
- Fuser Edge Temp Sensor
- Fuser Center Temp Amplifier Sensor
- Fuser Temp Compensation Sensor

Clutch Tests Tests the functionality of the clutches by giving service personnel the ability to energize/de-energize one clutch at a time.

- Registration Clutch
- Tray 1 (MPT) Turn Clutch
- Tray 2 Turn Clutch
- Tray 3 Turn Clutch
- Tray 4 Turn Clutch

Solenoid Tests Tests the functionality of the solenoids by giving service personnel the ability to energize/de-energize one solenoid at a time.

- Tray 1 (MPT) Feed Solenoid
- Tray 2 Feed Solenoid
- Tray 3 Feed Solenoid
- Tray 4 Feed Solenoid

Maintenance Cleans the IDT rollers within the Imaging Unit.

- Clean Imaging Unit IDT Rollers

NVRAM Access This menu lets you read, set, or reset the following values:

- PostScript NVRAM Reset
- MCU NVRAM Store/Restore
- Toner Install Dates
- Toner CRUM Check
- CRU Life Reset
- CRU Life Read

IP Controller Diagnostics Tests the basic functions of the Image Processor Controller Board.

- RAM Read/Write Test

Exit Exits service diagnostics and reboots the printer.

For Authorized Service Personnel Use Only. Service Menu functions are to be used by Xerox service personnel and authorized service providers only. The printer can be damaged by improper use of the built-in service tests.

Service Diagnostic Tests

Test	Front Panel Display and Test Definition	
Print Service Menu Map - Prints the service diagnostics menu map and exits service diagnostics.		
General Status - Provides the following print engine status:		
Status	<No Status to Report> NOTE This is current status since entering diagnostics only. It is not a Fault Log. If Ready is reached, the register is cleared.	No Status to Report = the printer is online and ready to print. Displays an engine status that will prevent printing. Status is displayed sequentially, one line at a time.
Engine Board ROM Version	Engine FW: #.#.#	Displays the engine firmware version installed.
Printer Configuration	Memory: ###MB Hard Drive: Not Installed or Installed HCF: Installed Not Installed	Displays current memory installed. Detects presence of Hard Drive option. Detects presence of High-Capacity Feeder option.
Ambient Temperature/ Humidity	Temperature: XX °C Humidity: ## %	Displays the current Temperature and Humidity for the printer.
Fuser Temperature	Temperature: XX °C	Displays the printers current Fuser temperature.
Fault History	Device Status Jams Hardware Errors Firmware Errors Fan Motors CTD (ADC) Sensor Errors Fuser Failure Laser Failure Life Over Trays Miscellaneous CRUMS	Displays Fault occurrence since last power cycle.
Test Prints - Prints test prints stored in the Engine Control Board. The prints are used by service personnel to identify, repair and validate the operability of the printer.		

Test	Front Panel Display and Test Definition	
Blank Page Print	Continuously prints blank pages until stopped by the user.	See "Front Panel Test Prints" on page 5-4, "Adjustments" on page 6-3, and "Resetting NVRAM" on page 6-4, for specific test print information.
Standard Test Print	Continuously prints the Step pattern until stopped by the user.	
Custom Test Print	Prints the test pattern using the custom print parameters defined by the user until stopped by the user.	
Current Test Print Set-Up	Displays the print setup for the Current Test Print.	
Custom Test Print Parameters	Allows various print parameters to be changed for the Custom Test Print.	
Motors/Fans Tests - Tests the functionality of motors and fans by giving service personnel the ability to energize/de-energize the motor and fans one at a time.		
Main Motor	Normal Speed Half Speed One Third Speed Normal Speed Continuous Half Speed Continuous One Third Speed Continuous	Audible verification of motor functionality. The motor tests are pulsed or continuous.
Duplex Motor	Forward Normal Speed Forward Half Speed Forward Double Speed Reverse Normal Speed Reverse Half Speed Reverse Double Speed Fwd Normal Speed Continuous Fwd Half Speed Continuous Fwd Double Speed Continuous Rev Normal Speed Continuous Rev Half Speed Continuous Rev Double Speed Continuous	Audible verification of motor functionality.
Fuser Motor	Normal Speed Half Speed One Third Speed Normal Speed Continuous Half Speed Continuous One Third Speed Continuous	Audible verification of motor functionality.

Test	Front Panel Display and Test Definition	
Developer Motor Caution: Do NOT allow this motor to run any longer than necessary to verify operation.	Normal Speed Half Speed One Third Speed	Audible verification of motor functionality. Caution: Only run the developer motor test once per power cycle to avoid excessive amounts of toner being forced inside the developer resulting in possible damage.
HCF/LTA Motor	Normal Speed Half Speed Normal Speed Continuous Half Speed Continuous	Audible verification of motor functionality.
Toner Motor Yellow Toner Motor Magenta Toner Motor Cyan Toner Motor Black	Normal Speed	Audible verification of motor functionality. Caution: Only run the Toner Motor tests once per power cycle to avoid toner spillage inside the Imaging Unit cavity and packing the auger tubes with toner.
Rear Fan	High Speed Low Speed High Speed Continuous Low Speed Continuous	Audible verification of motor functionality. Check for airflow.
Fuser Fan	High Speed Low Speed High Speed Continuous Low Speed Continuous	Audible verification of motor functionality. Check for airflow.
Sensor/Switch Tests - Tests the functionality of the sensors and switches by giving service personnel the ability to input actuation and state changes of all sensors and switches.		
Interlock Switch	Sensor is: ON Sensor is: OFF	Front Door OPEN Front Door CLOSED
Registration Sensor	Sensor is: OFF Sensor is: ON	This test continuously cycles paper through the printer. The sensor state changes from off to on as the paper passes through the Registration Chute. Note: This test can also be used as a paper path transport test when troubleshooting Jam conditions.

Test	Front Panel Display and Test Definition	
Exit Sensor	Sensor is: OFF Sensor is: ON	Actuate/de-actuate the Exit Actuator (PL8.1.7) located in the Fuser to toggle the sensor state.
Duplex Sensor	Sensor is: OFF Sensor is: ON	Actuate/de-actuate the Duplex Actuator (PL6.1.13) located on the Chute Assembly Out to toggle the sensor state.
Full Stack Sensor	Sensor is: OFF Sensor is: ON	Actuate/de-actuate the Output Tray Full Actuator (PL6.1.4) at the output tray to toggle the sensor state.
Black Toner (K) Low Cyan Toner (C) Low Magenta Toner (M) Low Yellow Toner (Y) Low	Toner is Low Toner is NOT Low	Displays current state of the sensor.
Black Toner Cartridge Present Cyan Toner Cartridge Present Magenta Toner Cartridge Present Yellow Toner Cartridge Present	Sensor is: OFF Sensor is: ON	Toggle the Toner Cartridge In switch (PL 10.1.22) for the appropriate color to change the sensor state. Toner Cartridge is in the LOCKED position. Toner Cartridge is in the UNLOCKED position.
Black Toner CRUM Sensor Cyan Toner CRUM Sensor Magenta Toner CRUM Sensor Yellow Toner CRUM Sensor	Sensor is: OFF Sensor is: ON	Remove the appropriate toner cartridge and depress the Toner Cartridge In switch (PL 10.1.22) to change the sensor state. Toner Cartridge is in the LOCKED position. Toner Cartridge is in the UNLOCKED position.

Test	Front Panel Display and Test Definition	
Tray 2 Low Paper Tray 3 Low Paper Tray 4 Low Paper	Size: XXXX Paper is Not Low Paper is Low	Move the Rear Guide in the paper tray to the desired paper size and verify the sensor output matches the paper size selected. Insert and fill Tray [2] [3] [4] with paper to the fill line. Insert one sheet of paper in Tray [2] [3] [4] to change the sensor state.
Tray 1 (MPT) No Paper Sensor	Paper is Not Present Paper is Present	Insert Paper into Tray 1. Toggle the Tray 1 No Paper Actuator (PL6.1.37) to change the state.
Tray 2 No Paper Sensor Tray 3 No Paper Sensor Tray 4 No Paper Sensor	Paper is Not Present Paper is Present	Insert Tray [2] [3] [4] with an adequate amount of paper. Toggle the No Paper Actuator.
Transfer Roll Toner Full Sensor	Toner Waste [Not] Full	Block the Toner Full Sensor (PL5.1.13) to change the sensor state.
Image Unit Not Installed Sensor	Image Unit is [Not] Present	Open Door C to change the state of the Switch.
Fuser Fan Alarm Sensor	Fuser Fan Alarm Sensor is: OK Failure	Status only Note: Perform a test print immediately prior to performing this test.
Rear Fan Alarm Sensor	Rear Fan Alarm Sensor is: OK Failure	Status only Note: Perform a test print immediately prior to performing this test.
CTD (ADC) Sensor	Dark Value: # Light Value: ### Sensor OK	Status only Remove the transfer roller to observe change of state.

Test	Front Panel Display and Test Definition	
OHP Sensor	OHP Absence of Media Paper	Reports "Paper" if opaque media is present. Reports "OHP or Absence of Media" if OHP or no media is present. Manually insert a sheet of paper backwards through the Registration Chute Assembly (PL9.1.6) until the state of the sensor changes to "Paper".
Fuser Center Temp Sensor	<Fuser Center Temp Sensor> Fuser (Not) Ready Sensor (Failure) is OK	Remove fuser to change sensor state.
Fuser Edge Temp Sensor	<Fuser Edge Temp Sensor> Fuser (Not) Ready Sensor (Failure) is OK	Remove fuser to change sensor state.
Fuser Center Temp Amplifier	<Fuser Center Temp Amplifier> Fuser (Not) Ready Temperature Amplifier (Failure) is OK	Remove fuser to change sensor state.
Fuser Temp Compensation	<Fuser Temp Compensation> Fuser (Not) Ready Compensation (Failure) is OK	Remove fuser to change sensor state.
Clutch Tests - Tests the functionality of the clutches by giving service personnel the ability to energize/de-energize one clutch at a time.		
Registration Clutch Tray 1 (MPT) Turn Clutch Tray 2 Turn Clutch Tray 3 Turn Clutch Tray 4 Turn Clutch	Clutch is: ON Clutch is: OFF	Audible verification of Clutch functionality. You should hear the clutch engage and disengage (click) on and off continuously until test is ended by pressing Cancel.
Solenoid Tests - Tests the functionality of the solenoids by giving service personnel the ability to energize/de-energize one solenoid at a time.		

Test	Front Panel Display and Test Definition	
CRU Life Read	Black Toner (K) Life Cyan Toner (C) Life Magenta Toner (M) Life Yellow Toner (Y) Life Transfer Roller Life Read Printer Page Count Imaging Unit Count 1: number of sheets fed through imaging unit Count 2: Drum rotations Count 3 - 6: [Y] [M] [C] [K] dispense time Fuser Life Save Engine NAVRAM	Accesses the various life counts stored in NAVRAM and allows values to be saved when the Engine Control Board is changed.
CRU Life Restore	Restore Engine NAVRAM	Used after Engine Control Board replacement to restore the previously saved life values to NAVRAM.
IP Controller Diagnostics - Tests the basic functionality of the Image Processor Board.		
RAM Read/Write Test	Executing..... Passed	Does an extended memory test on the Image Processor Board. Note: Cycle power to the printer after executing this test.
Exit - Exits service diagnostics and reboots the printer.		

Jam History Error Codes Table

Jam History, located in the Troubleshooting/Service Tools menu on the Front Panel, uses a two field format. The first field represents the Jam location. The second field indicates the page count when the jam occurred.

Front Panel Message	Help Text/Code	Jam History Code
Misfeed at Tray 1 (MPT)	Jam T1/155	1
Misfeed at Tray 2	Jam T2/156	2
Misfeed at Tray 3	Jam T3/157	3
Misfeed at Tray 4	Jam T4/158	4
Jam at Fuser	Jam F/152	5
Jam at Duplex	Jam D/153	6
Jam at Registration Roller	Jam RR/154	7

Error Messages and Codes Summary Table

Error Type	Front Panel Message	Help Text/Code
Jam Errors		
	Jam at Fuser	Jam F/152
	Jam at Duplex	Jam D/153
	Jam at Registration Roller	Jam RR/154
	Misfeed at Tray 1 (MPT)	Jam T1/155
	Misfeed at Tray 2	Jam T2/156
	Misfeed at Tray 3	Jam T3/157
	Misfeed at Tray 4	Jam T4/158
Door and Cover Errors		
	Close Front Door	
Consumable/Routine Maintenance Item Errors		
	Install or Reseat Imaging Unit	
	Replace Imaging Unit or Imaging Unit is at End of Life	
	Install or Reseat Transfer Roller	
	Replace Transfer Roller or Transfer Roller is at End of Life	
	Install or Reseat Fuser	
	Replace Fuser or Fuser is at End of Life	
	Install or Lock [Y] [M] [C] [K] Toner Cartridge	
	Replace [Y] [M] [C] [K] Toner Cartridge or [Y] [M] [C] [K] Toner Cartridge Empty	
	Dusty Density Sensor	
	Remove Ribbon From [Y] [M] [C] [K] Toner Cartridge	
Tray and Media Errors		
	Output Tray is Full, Unload Paper	
	Insert Tray [2] or Tray [2] missing	
	Insert Tray [3] [4] or Tray [3] [4] missing	
	Tray [2] Paper is Low	
	Tray [3] [4] Paper is Low	
	Tray 1 (MPT) Out of Paper/Load Paper	
	Tray [2] [3] [4] Out of Paper/Load Paper	

Error Type	Front Panel Message	Help Text/Code
Media Mismatch Errors		
	Wrong Paper Size/Load Tray 1 (MPT) with [size] [type]	
	Wrong Paper Size/Load Tray [2] [3] [4] with [size] [type]	
Fatal Error Messages and Codes		
	Laser Failure	07, 08, 09, 10, 11
	Density Sensor Failure or Low Density Failure	13, 14, 15, 16
	Fuser Failure	40, 41, 42, 43, 44, 45, 46, 47
	Fuser Fan Failure	50
	Rear Fan Failure	51
	Generic Fan Failure	52
	Engine Firmware Failure	70, 71, 72, 73, 74, 77, 78, 79
	Imaging Unit Firmware Failure	75
	Fuser Firmware Failure	76
	Controller to Engine Communications Failure	81
	Engine NVRAM Failure	83
	[Y] [M] [C] [K] Toner Cartridge Failure	86, 87, 88, 89
	Replace [Y] [M] [C] [K] Toner Cartridge	90, 91, 92, 93, 96, 97, 98, 99
	Non-Phaser 6250 Fuser	94
	Non-Xerox Imaging Unit	95
	Environment Sensor Failure	102

Jam Errors

Jam at Fuser: Jam F

- Reseat the Fuser.
- Remove the Fuser and check for any obstructions, media or debris.
- Cycle printer power.
- If the problem persists, follow the procedure below.

Troubleshooting Reference

Applicable Parts	Wiring and Plug/Jack Map References
Fuser, PL 8.1.1	“Drive Section” on page 10-18
Exit Sensor/Actuator, PL 8.1.7	“Fuser Assembly” on page 10-21
Motor Driver Board, PL 12.1.12	“Map 1” on page 10-6

Warning

To avoid the potential of electric shock, ensure the power to the printer is off and the power cord is disconnected from the wall outlet prior to performing Step 2 of the following troubleshooting procedure..

Troubleshooting Procedure

Steps	Actions and Questions	Yes	No
1	Check the following for evidence of fault or damage: Exit Actuator & Sensor, PL 8.1.7 Fuser Assembly, PL 8.1.1 Front Cover, PL 1.1.2 Chute Assembly In, PL 5.1.1 Transfer Roller, PL 8.1.12 Imaging Unit, PL 9.1.3	Replace the part(s) concerned.	Go to Step 2.
2	Remove the Fuser and check for broken or bent pins.	Replace the parts concerned.	Go to Step 3.
3	Reinstall the Fuser. Does error recur after the Fuser Assembly has been replaced?	Go to Step 4.	Complete.
4	Use service diagnostics to test the Exit Sensor. Does the sensor function correctly?	Go to Step 9.	Replace the Fuser Assembly. Go to Step 5.
5	Does error recur after the Fuser is replaced	Go to Step 6.	Complete.

Troubleshooting Procedure (Continued)

Steps	Actions and Questions	Yes	No
6	Insert a sheet of paper into the Fuser Assembly. Verify the voltage on the Fuser Harness P138-3 <=> P138-2 is 0VDC.	Go to Step 8.	Go to Step 7.
7	Check all pins on the FSR 2 (Fuser) Harness Assembly PL5.1.10 for continuity.	Go to Step 8.	Replace the Assembly, Harness FSR 2 PL 5.1.9.
8	Check all pins on the Harness Assembly Front 1A for continuity.	Go to Step 9].	Replace the Harness Assembly Front 1A, PL 13.1.7.
9	If possible print one sheet of paper. Does the Fuser Motor Turn? Inspect the gears for damage.	Replace the gear(s) if defective.	Go to Step 10.
10	Use service diagnostics to test the Fuser Motor. Does the Fuser Motor function correctly?	Replace Engine Control Board, page 8-107.	Go to Step 11.
11	Verify the voltage between P 52-1 <=> P 60-2 on the Motor Driver Board is +24 VDC.	Go to Step 12.	Replace the Motor Driver Board, page 8-101.
12	Replace the Fuser Drive Assembly PL 5.1.18. Does the Fuser Motor function correctly?	Complete	Go to Step 13.
13	Check the DRV 1 Harness for continuity.	Replace the Engine Control Board, page 8-107.	Replace the DRV 1 Harness, PL 13.1.2.

Jam at Duplex: Jam D

- Check for any obstructions or debris in the duplexer or paper path.
- Cycle printer power
- If the problem persists, follow the procedure below.

Troubleshooting Reference Table

Applicable Parts	Wiring and Plug/Jack Map References
Duplex Sensor, PL 6.1.4	“Drive Section” on page 10-18
Actuator Kit, PL 15.1	“Paper Feed” on page 10-25
Chute Assembly Exit, PL 7.1.7	“Map 1” on page 10-6

Troubleshooting Procedure Table

Steps	Actions and Questions	Yes	No
1	Check the following for evidence of fault or damage: Chute Assembly Exit, PL 7.1.7 Duplex Motor Assembly, PL 7.1.8 Duplex Sensor, PL 6.1.4 Duplex Actuator, PL 6.1.5 Chute Assembly Out, PL 6.1.1	Replace the damaged part.	Go to Step 2.
2	Use service diagnostics to test the Duplex Sensor. Does the sensor function correctly?	Go to Step 7.	Replace the sensor and Go to Step [3].
3	Does the printer function correctly after the Duplex Sensor is replaced?	Complete	Go to Step 4.
4	Block the Duplex Sensor and verify the voltage between J 139-3<=>J 139-2 is 0 VDC.	Go to Step 6.	Go to Step 5.
5	Check the Front 2 Harness for continuity. See “Paper Feed” on page 10-25.	Go to Step 6.	Replace the Front 2 Harness Assembly, PL 6.1.2.
6	Check P 139<=>J 13 on the Front 1A Harness for continuity. See “Paper Feed” on page 10-25.	Replace the Engine Control Board, page 8-107.	Replace the Assembly, Front 1A, PL 13.1.7.
7	If possible, print 1 sheet of paper in Duplex Mode and check to see if the sheet has reversed in the printer.	Replace the Chute Assembly Exit, page 8-62.	Go to Step 8.

Troubleshooting Procedure Table (Continued)

Steps	Actions and Questions	Yes	No
8	Use service diagnostics to test the Duplex Motor. Actuate the Interlock Switch during the test.	Replace the Chute Assembly Exit, page 8-62.	Go to Step 9.
9	Verify the voltage between P 50-1<=>P 60-2 on the Motor Driver Board is +24 VDC.	Go to Step 10.	Replace the Motor Driver Board, page 8-101.
10	Check J 131<=>J 50 on the Duplex Harness for continuity. See "Drive Section" on page 10-18.	Go to Step 11.	Replace the Duplex Harness Assembly, PL 6.1.23.
11	Does the error recur after replacing the Duplex Motor?	Go to Step 12.	Complete
12	Check J 12 <=> J 42 pins on the DRV 2 Harness for continuity. See "Drive Section" on page 10-18.	Replace the Engine Control Board, page 8-107.	Replace the Assembly, Harness DRV2-2, PL 13.1.3.

Jam at Registration

A “Jam at Registration” message may indicate a dirty or blocked paper path or the failure of one or more components, resulting in jams in the Registration Chute Assembly (PL9.1.6) or it’s proximity.

Due to the short paper path, this jam can be caused by several components within the printer. The initial actions outlined below may provide some basic information needed to identify the source of the problem. After completion of the Initial Actions, use the Troubleshooting Procedure Table to isolate and correct the specific problem.

Initial Actions

1. Query the customer about the types of paper being used. If it is not on the recommended media list, attempt to determine if this could be contributing to the jamming. Recycled, multi-purpose or copier papers tend to contaminate the paper path (rollers, sensors etc.) and may necessitate more frequent cleaning. Constant use of special papers such as labels or business cards can also contribute to a higher jam rate.
2. Make sure the correct tray loading and setup procedures are followed (securing the tray backstop and guides, selecting the correct paper type at the Control Panel, fanning the paper, etc.).
3. Make sure the printer is plugged directly into an electrical outlet. Using extension cords or a power strip is not recommended.
4. Make every attempt to establish a jam rate prior to starting any work. If possible, print a Printer Status page or usage profile report and note the page count between jams.
5. Try to determine if the jamming is occurring in one tray but not another. This will help identify any dirty or defective parts.
6. Clear the paper path of any existing jams and paper debris. Start at the Turn Chute (PL3.1.2) and work up to the Registration Chute Assembly (PL9.1.6.)
7. Using a slightly damp (water only) lint free cloth, clean the Paper Feed Rollers (PL2.1.2/ PL3.3.23) and Pick Rollers (PL3.3.3) in the paper tray and tray slot.
8. Clean the Registration Chute Assembly’s rubber roller. The roller should be black and pliable.
9. Remove the Registration Chute Assembly and clean the OHP (PL9.1.12) and Registration (PL9.1.8) Sensors and surrounding area of paper dust and debris.
10. Check for excessive waste toner around the Transfer Roller (PL8.1.12) area. Replace the Transfer Roller if needed.
11. Test to determine if the jam has cleared and the jam rate has improved.

Troubleshooting Reference Table

Applicable Parts	Wiring and Plug/Jack Map References
Chute Assembly Registration, PL 9.1.6	"Paper Feed" on page 10-25
Fuser, PL 8.1.1	"Fuser Assembly" on page 10-21
Feed Roller, PL 3.3.3	
Transfer Roller, PL 8.1.12	

Note

Identify the pertinent symptom by examination of media travel through the media path, then follow the troubleshooting step associated with that symptom. Four conditions are addressed in the following table:

- The leading edge extends approximately 1.5 inches from the Registration Chute. Start at Step 1.
- The leading edge reaches the Fuser and may accordion fold at the Fuser entrance. Start at Step 4.
- A momentary, abnormal squealing noise is heard, immediately followed by a Jam at Registration error message. This behavior indicates a Fuser stall condition. A Fuser stall could result from the Fuser Drive's inability to provide enough torque to turn the Fuser rollers following a period of Power Saver mode, or low ambient operating temperatures (less than 20 C, 68 F). Start at Step 7.

Note

Snippets are available for download from the Partner's web site to correct Fuser Stalls caused by Fuser Drive ramp timing or low operating temperatures. Indicate installation of the FMS snippet in the RID service history text field.

- The leading edge is accordion folded at the Turn Chute. Start at Step 12.

Remember to remove replacement parts installed during troubleshooting that did not resolve the problem.

Troubleshooting Procedure Table

Steps	Action and Questions	Yes	No
1	Check for paper jammed in the Registration Chute Assembly. Does the leading edge extend approximately 1 to 1 1/2 inches through the assembly?	Go to Step 2.	Go to Step 4.

Troubleshooting Procedure Table (Continued)

Steps	Action and Questions	Yes	No
2	<p>Use Service Diagnostics to test the following parts within the Registration Chute Assembly:</p> <ul style="list-style-type: none"> ■ Registration Sensor (PL9.1.8) ■ OHP Sensor (PL9.1.12) ■ Registration Clutch (PL9.1.6) <p>Replace any defective parts. Does the problem persist?</p>	Go to Step 3.	Complete.
3	<p>Replace the Registration Chute Assembly (page 8-71). Does the problem persist?</p>	See Jam at Registration Roller (page 3-28).	Complete.
4	<p>Check for paper jammed in the Registration Chute Assembly. Does the leading edge extend up to the Fuser entrance?</p>	Go to Step 5.	Go to Step 8.
5	<p>Turn the printer's power switch Off and allow the Fuser to cool completely. Remove the Fuser (page 8-5) and check for damage, wear, or debris. Is the Fuser damaged or contain debris?</p>	Repalce the Fuser, or clean if necessary.	Go to Step 6.
6	<p>Reinstall the Fuser making sure both the left and right amber gold Fuser Locks are in the forward (slide towards the rear of the printer) locked position. Turn the power switch On. Does the problem persist?</p>	See Jam at Registration Roller (page 3-28).	Complete.
7	<p>Listen for a "Fuser stall," which is a momentary, abnormal squealing noise immediately followed by a "Jam at Registration" message. This usually occurs when the printer is exiting Power Saver mode and the Fuser is cold. Does a Fuser stall condition exist?</p>	Go to Step 8.	Go to Step 11

Troubleshooting Procedure Table (Continued)

Steps	Action and Questions	Yes	No
8	<p>Check for a previous installation of the Fuser Motor Stall (FMS) snippet using 6250FMSCheck.psx. Download this snippet from the Partner or Customer Support web site.</p> <p>NOTE The printer must be at the Ready state to receive the snippet.</p> <p>If the snippet has been installed, a page is printed containing the lines: 6250FMSCheck.ps has been sent to the printer! : [219/219] Power printer OFF then ON to finish check.</p> <p>If the FMS snippet has not been installed, the page reads: 6250FMSFix.ps HAS NOT BEEN SENT TO THE PRINTER! [199]</p> <p>If the current limiting values were undefined, the page reads: PRINTER NOT READY!: [187] Wait until the printer is in READY State and resend file.</p> <p>Has the FMS snippet been installed?</p>	Go to Step 9.	Go to Step 10.
9	<p>Reset NVRAM values for Fuser Motor current limiting using 6250FMSOrig.psx. Download this snippet from the Partner or Customer Support web site.</p> <p>NOTE The printer must be at the Ready state to receive the snippet.</p> <p>Following installation, a page prints with the lines: Printer updated to original value: [199/199] Power printer OFF then ON to finish upgrade.</p> <p>If the snippet did not installed correctly, the page reads: PRINTER UPDATE UNSUCCESSFUL! [219/219] Wait until the printer is in READY State and resend file.</p> <p>Are the NVRAM values reset?</p>	Go to Step 10.	Repeat Step 9.

Troubleshooting Procedure Table (Continued)

Steps	Action and Questions	Yes	No
10	<p>Install the current the FMS snippet 6250FMSFix.psx. Download this snippet from the Partner or Customer Support web sites.</p> <p>NOTE The printer must be at the Ready state to receive the snippet.</p> <p>Following installation, a page prints with the lines: Printer updated successful!: [219/219] Power printer OFF then ON to finish upgrade.</p> <p>If the snippet did not installed correctly, the page reads: PRINTER UPDATE UNSUCCESSFUL! [199/199] Wait until the printer is in READY State and resend file.</p> <p>Does the problem persist?</p>	Go to Step 8.	Go to Step 9.
11	<p>Check the Fuser for wear, damage, or debris. Replace if necessary. Does the problem persist?</p>	See Jam at Registration Roller (page 3-28).	Complete.
12	<p>Check for paper jammed in the Turn Chute Assembly. Is the leading edge accordion folded at the Turn Chute?</p>	Go to Step 13.	See Jam at Registration Roller (page 3-28).
13	<p>Use Service Diagnostics to test the following parts within the Registration Chute Assembly:</p> <ul style="list-style-type: none"> ■ Registration Sensor (PL9.1.8) ■ OHP Sensor (PL9.1.12) ■ Registration Clutch (PL9.1.6) <p>Replace any defective parts. Does the problem persist?</p>	Go to Step 14.	Complete.
14	<p>Replace the Registration Chute Assembly (page 8-71). Does the problem persist?</p>	Go to Step 15.	Complete.
15	<p>Replace the Feed Rollers (page 8-18). Does the problem persist?</p>	See Jam at Registration Roller (page 3-28).	Complete.

Jam at Registration Roller: Jam RR

- Check the paper path especially in the area of the registration roller and turn chute assembly for obstruction or debris.
- Try picking paper from a different tray.
- Ensure the media being used is a supported type.
- Remove, fan, and reload the media.
- Cycle printer power.
- If the problem persists, follow the procedure below.

Note

In some instances the error code will clear after power is cycled to the printer, but will reappear with the next print. Check for a piece of paper fan-folded behind the turn chute assembly or below the registration roller.

Troubleshooting Reference Table

Applicable Parts	Wiring and Plug/Jack Map References
Chute Assembly Registration, PL 9.1.6	"Paper Feed" on page 10-25

Troubleshooting Procedure Table

Steps	Action and Questions	Yes	No
1	Check the following for evidence of fault or damage. Registration Actuator, PL 9.1.9 Chute Assembly Registration, PL 9.1.6	Clean or replace the parts concerned.	Go to Step 2.
2	Use service diagnostics to test the Registration Sensor. Does sensor function correctly?	Go to Step 6.	Go to Step 3.
3	Check that the connection between the Harness and the Registration Sensor is properly connected and seated.	Go to Step 4.	Reconnect properly.
4	Check J181 <=> J18 on the Registration Clutch Harness for continuity. See "Paper Feed" on page 10-25.	Go to Step 5.	Replace the Chute Assembly Registration, page 8-71.
5	Verify the voltage between P/J 18-3 <=> P/J 18-2 on the Engine Control Board is 0 VDC.	Go to Step 6.	Replace the Registration Sensor, page 8-73.

Troubleshooting Procedure Table (Continued)

Steps	Action and Questions	Yes	No
6	Use service diagnostics to test the Registration Clutch. Close the Interlock Switch during the test. Does the clutch function correctly?	Go to Step 8.	Go to Step 7.
7	Remove the connector J18. Is J 18-4 <=> J 18-5 less than 200Ω?	Go to Step 8.	Replace the Chute Assembly Registration, page 8-71.
8	Verify the voltage between P 18-4 <=> P 18-2 on the Engine Control Board is +24 VDC. Close the Interlock Switch while checking the voltage.	Replace the Chute Assembly Registration, page 8-71.	Replace the Engine Control Board, page 8-107.

Misfeed at Tray 1 (MPT): Jam T1

- Ensure that Tray 1 is securely attached to the printer.
- Try picking paper from a different tray.
- Check the paper path for obstructions or debris.
- Ensure that the media guides are set correctly.
- Cycle printer power.
- If the problem persists, follow the procedure below.

Troubleshooting Reference Table

Applicable Parts	Wiring and Plug/Jack Map References
Roll Feed Assembly, PL 6.1.27	"Paper Tray 1" on page 10-17
Paper Present Sensor, PL 6.1.4	"Paper Feed" on page 10-25
MPT Actuator, PL 6.1.37	"Drive Section" on page 10-18
MPT Feed Solenoid, PL 6.1.40	"Main Wiring Diagram" on page 10-15
Chute Assembly Registration, PL 9.1.6	

Troubleshooting Procedure Table

Steps	Actions and Questions	Yes	No
1	Check the following parts for fault or damage: Tray 1 (MPT) Registration Sensor PL 9.1.8 Main Drive Assembly PL 11.1.14 Remove any foreign objects or debris in the paper path.	Replace any damaged or excessively worn parts.	Go to Step 2.
2	Use service diagnostics to test the Registration Sensor. Does the sensor function normally?	Go to Step 6.	Go to Step 3.
3	Check that the connection between the Harness and the Registration Sensor is properly connected and seated.	Go to Step 4.	Connect or replace the faulty part.
4	Check J 18-4 <=> J 18-5 on the Registration Clutch Harness for continuity. See "Paper Feed" on page 10-25.	Go to Step 5.	Replace the Registration Chute Assembly, page 8-71.

Troubleshooting Procedure Table (Continued)

Steps	Actions and Questions	Yes	No
5	Verify the voltage between P/J18-3 <=> P/J18-2. This measurement point can be accessed under the electric housing assembly (See page 8-71) on the Engine Control Board is0 VDC.	Replace Sensor, Registration, page 8-73.	Go to Step 6.
6	If possible, print a sheet of paper from the MPT. Does the Main Drive motor function properly?	Go to Step 16	Go to Step 7
7	Use service diagnostics to test the Main Drive Motor. Does the Main Drive Motor turn?	Replace the Engine control Board, page 8-107.	Go to Step 8.
8	Verify the voltage between P/J50-1 <=> P/J60-2 on the Motor Driver Board is +24 VDC	Go to Step 12.	Go to Step 9.
9	Use service diagnostics to test the Interlock Switch. Does the Interlock switch function correctly?	Go to Step 10.	Replace the , Motor Driver Board, page 8-101.
10	Verify the voltage between SW-1 <=> P/J60-2 and SW-2 <=> P/J60-2 on the Motor Driver Board is +24 VDC. Close the Interlock Switch.	Replace the , Motor Driver Board, page 8-101.	Go to Step 11.
11	Check the power supply by verifying the voltage between P/J60-1 <=> P/J60-2 on the Motor Driver Board is +24 VDC.	Replace the Motor Driver Board, page 8-101.	See "DC Power Supply Troubleshooting" on page 4-13.
12	Check the power supply by verifying the voltage between P/J61-8 <=> P/J61-7 on the Motor Driver Board is +5 VDC.	Go to Step 13.	Go to Step 14.
13	Check the power supply by verifying the voltage between P/J61-6 <=> P/J61-5 on the Motor Driver Board is +3.3 VDC.	Go to Step 15.	Go to Step 14.
14	Check the LVNC3 Harness for continuity. See "Main Wiring Diagram" on page 10-15.	See "DC Power Supply Troubleshooting" on page 4-13.	Replace the Harness LVNC3 PL 13.1.1.
15	Check the DRV 1 Harness for continuity. See "Drive Section" on page 10-18.	Replace in the following order: Main Drive Assembly, page 8-94, Engine Control Board, page 8-107.	Replace the DRV 1 Harness Assembly, PL 13.1.1.

Troubleshooting Procedure Table (Continued)

Steps	Actions and Questions	Yes	No
16	Perform Steps 1 through 3 on page 8-19. Open and close the front door. Observe the Turn Roller. Does the Turn Roller turn while the machine is warming up?	Go to Step 19.	Go to Step 17.
17	Using service diagnostics, test the Tray 1 Turn Clutch. Does the Turn Clutch Assembly function normally? In the test, actuate the Interlock switch.	Check the Clutch for slip or the gear for damage. Replace if necessary.	Go to Step 18.
18	Remove the clutch connector J19. Check the following pins; Is J19-1 <=> J19-2 less than 200Ω?	Replace the Engine Control Board, page 8-107.	Replace the MPT Turn Clutch, page 8-34.
19	Does the Feed Gear in Tray 1 turn when printing 1 sheet of paper?	Check parts for damage or obstructions in the paper path.	Go to Step 20.
20	Use service diagnostics to test the Tray 1 Feed Solenoid. Does the solenoid actuate? In the test, actuate the Interlock Switch.	Check the spring and stopper of the Feed Solenoid.	Go to Step 21.
21	Remove the Tray 1 Feed Solenoid connector J132; Is J132-1 <=> J132-2 less than 100Ω?	Go to Step 22.	Replace the Tray 1 Feed Solenoid.
22	Check the Front 2 Harness for continuity.	Replace the Engine Control Board, page 8-107.	Replace Front 2 Harness Assembly, PL 6.1.2.

Misfeed at Tray 2: Jam T2

- Try picking paper from a different tray.
- Ensure that Tray 2 is free from defects and installed properly.
- Remove, fan, and reload media in Tray 2.
- Remove any obstructions or debris in the paper path.
- Ensure that the media in Tray 2 is a supported type and size.
- Ensure that the tray guides are set correctly.
- Cycle printer power.
- If the problem persists, follow the procedure below.

Troubleshooting Reference Table

Applicable Parts	Wiring and Plug/Jack Map References
Paper Pick Roller Kit, PL 3.3.3	"Paper Tray 1" on page 10-17
Paper Feed Roller Kit, PL 3.3.23	"Paper Feed" on page 10-25
Paper Pick Assembly, PL 3.3.1	"Drive Section" on page 10-18
Chute Assembly Registration, PL 9.1.6	"Main Wiring Diagram" on page 10-15

Troubleshooting Procedure Table

Steps	Actions and Questions	Yes	No
1	Check the following parts for fault or damage: Check for worn or damaged rollers and gears on the Paper Pick Assembly and the Feed Roller on Tray 1. Check Tray 1 for damage. Registration Sensor PL 9.1.8 Main Drive Assembly PL 11.1.14	Replace any damaged or excessively worn parts.	Go to Step 2.
2	Use service diagnostics to test the Registration Sensor. Does the sensor function normally?	Go to Step 6.	Go to Step 3.
3	Check that the connection between the Harness and the Registration Sensor is properly connected and seated.	Go to Step 4.	Connect or replace the faulty part.
4	Check the Registration Clutch Harness for continuity. See "Paper Feed" on page 10-25.	Go to Step 5.	Replace the Registration Chute Assembly, page 8-71.

Troubleshooting Procedure Table (Continued)

5	Is the voltage between P/J18-3 <=> P/J18-2, located under the electric housing assembly (see page 8-71) on the Engine Control Board is 0 VDC.	Replace Registration Sensor, page 8-73.	Go to Step 6.
6	If possible, print a sheet of paper from Tray 1. Does the Main Drive Motor function properly?	Go to Step 16.	Go to Step 7.
7	Use service diagnostics to test the Main Drive Motor. Does the Main Drive Motor turn?	Replace the Engine control Board, page 8-107.	Go to Step 8.
8	Verify the voltage between P/J50-1 <=> P/J60-2 on the Motor Driver Board is +24 VDC	Go to Step 12.	Go to Step 9.
9	Use service diagnostics to test the Interlock Switch. Does the Interlock switch function correctly?	Go to Step 10.	Replace the , Motor Driver Board, page 8-101.
10	Verify the voltage between SW-1 <=> P/J60-2 and SW-2 <=> P/J60-2 on the Motor Driver Board is +24 VDC. Close the Interlock Switch.	Replace the , Motor Driver Board, page 8-101.	Go to Step 11.
11	Check the power supply by verifying the voltage between P/J60-1 <=> P/J60-2 on the Motor Driver Board is +24 VDC.	Replace the Motor Driver Board, page 8-101.	See “DC Power Supply Troubleshooting” on page 4-13.
12	Check the power supply by verifying the voltage between P/J61-8 <=> P/J61-7 on the Motor Driver Board is +5 VDC.	Go to Step 13.	Go to Step 14.
13	Check the power supply by verifying the voltage between P/J61-6 <=> P/J61-5 on the Motor Driver Board is +3.3 VDC.	Go to Step 15.	Go to Step 14.
14	Check the LVNC3 Harness for continuity. See “Main Wiring Diagram” on page 10-15.	See “DC Power Supply Troubleshooting” on page 4-13.	Replace the Harness LVNC3 PL 13.1.1.
15	Check the DRV 1 Harness for continuity. See “Drive Section” on page 10-18.	Replace in the following order: Main Drive Assembly, page 8-94 Engine Control Board, page 8-107.	Replace the DRV 1 Harness Assembly, PL 13.1.1

Troubleshooting Procedure Table (Continued)

16	Perform Steps 1 through 3 on page 8-19. Open and close the front door. Observe the Turn Roller. Dose the Turn Roller turn while the machine is warming up?	Go to Step 21.	Go to Step 17.
17	Use service diagnostics to test the Tray 1 Turn Clutch. During the test, close the Interlock Switch.	Check the clutch and gears for damage. Replace if necessary.	Go to Step 18.
18	Verify the voltage between P/J47-13<=> P/J60-2 on the Motor Driver Board is +24 VDC.	Go to Step 19.	Replace the Motor Driver Board, page 8-101.
19	Check the Feeder Harness for continuity.	Go to Step 20.	Replace the Feeder Harness Assembly, PL 3.3.24.
20	Remove the clutch connector J475. Is J475-1 <=> J475-2 less than 200Ω?	Go to Step 21.	Replace the Paper Pick Assembly, PL 3.3.1.
21	If possible print one sheet of paper. Did the paper attempt to feed?	Check parts for damage or obstructions in the paper path.	Go to Step 22.
22	Use service diagnostics to test the Tray 1 Feed Solenoid. Does the solenoid actuate? During the test actuate the Interlock Switch.	Check the spring and stopper on the Feed Solenoid.	Go to Step 23.
23	Verify the voltage between P/J47-11 <=> P/J60-2 on the Motor Driver Board is +24 VDC.	Go to Step 24.	Replace the Motor Driver Board, page 8-101.
24	Check the Feeder Harness for continuity.	Go to Step 25.	Replace the Feeder Harness Assembly, PL 3.3.24.
25	Remove the Solenoid connector J474. Is J474-1 <=> J474-2 less than 100Ω?	Go to Step 26.	Replace Feed Solenoid, PL 3.3.17.
26	Check the DRV2-2 Harness for continuity.	Replace the Engine Control Board, page 8-107.	Replace the DRV2-2 Harness Assembly, PL 13.1.3.

Misfeed at Tray 3: Jam T3

- Try feeding paper from another tray.
- Ensure that the paper path is free of obstructions and debris.
- Ensure that tray is installed correctly.
- Remove, fan, and reload the media in the tray.
- Ensure that the media in Tray 3 is a supported type and size.
- Cycle printer power.
- If the problem persists, follow the procedure below.

Troubleshooting Reference Table

Applicable Parts	Wiring and Plug/Jack Map References
Paper Pick Roller Kit, PL 14.4.3 (HCF) or PL 15.4.3 (STF)	"Paper Tray 3" on page 10-29
Paper Feed Roller Kit, PL 14.1.2 (HCF) or PL 15.1.2 (STF)	"Paper Feed" on page 10-25
HCF Paper Pick Assembly, PL 14.4.1 (HCF) or PL 15.4.1 (STF)	"Drive Section" on page 10-28 (HCF) or page 10-32 (STF)

Troubleshooting Procedure Table

Steps	Actions and Questions	Yes	No
1	Does the printer feed paper correctly from Tray 2?	Go to Step 2.	See "Misfeed at Tray 2 Jam T2" on page 3-33.
2	Does the lower tray assembly (LTA) (HCF or STF) Motor run when printing one sheet?	Go to Step 9.	Go to Step 3.
3	Use service diagnostics to test the LTA Motor. Does the LTA motor function correctly?	Replace the Engine Control Board, page 8-107.	Go to Step 4.
4	Verify the voltage between P/J84-3 <=> P/J81-1 on the Lower Feeder Circuit Board is +24 VDC	Go to Step 7.	Go to Step 5.
5	Verify the voltage between P/J81-2 <=> P/J81-1 on the Lower Feeder Circuit Board (LTA) is +24 VDC.	Replace the Lower Feeder Circuit Board, PL 14.5.1 or PL 15.5.1.	Go to Step 6

Troubleshooting Procedure Table (Continued)

Steps	Actions and Questions	Yes	No
6	Verify the connector between the LTA and the printer is connected properly and not damaged.	Replace the damaged part.	Go to Step 7.
7	Replace the LTA Motor. Does the error recur after the LTA Motor has been replaced with a new one?	Go to Step 8.	Complete
8	Perform Steps 1 through 3 on page 8-113. Open and close the front door. Observe the Turn Roller. Does the Turn Roller turn while the machine is warming up?	Go to Step 13.	Go to Step 9.
9	Use service diagnostics to test the Tray 3 Turn Clutch. During the test close the Interlock Switch. Does the Tray 3 Turn Clutch function correctly?	Check the Clutch for slipping or the gear for damage.	Go to Step 10.
10	Verify the voltage between P/J82-13 <=> P/J81-1 on the Lower Feeder Circuit Board (LTA) is +24 VDC.	Go to Step 11.	Replace the Lower Feeder Circuit Board, PL 14.5.1 or PL 15.5.1.
11	Check the Tray 3 Harness Assembly for continuity. See "Paper Tray 3" on page 10-29.	Go to Step 12.	Replace the Tray 3 Harness Assembly, PL 14.5.3 or PL 15.5.3.
12	Remove the clutch connector J825. Is J825-1 <=> J825-2 of the Tray 3 Turn Clutch Assembly less than 200 ohms?	Go to Step 13.	Replace the Tray 3 Turn Clutch Assembly, PL 14.4.18 or PL 15.4.18.
13	Does the Feed Gear in the Tray 3 Feeder turn when printing one sheet of paper?	Check the Tray 3 Feed Solenoid for damage.	Go to Step 14.
14	Use service diagnostics to test the Tray 3 Clutch Solenoid. Does the solenoid function correctly?	Check the stopper on the feed solenoid and replace if necessary.	Go to stop 15.
15	Verify the voltage between P/J82-11 <=> P/J81-1 on the Lower Feeder Circuit Board is +24 VDC.	Go to Step 16.	Replace the Lower Feeder Circuit Board, PL 14.5.1 or PL 15.5.1.

Troubleshooting Procedure Table (Continued)

Steps	Actions and Questions	Yes	No
16	Remove the Tray 3 Feed Solenoid connector J824; Is J824-1 <=> J824-2 less than 100 ohms?	Go to Step 17.	Replace the Tray 3 Feed Solenoid, PL 14.4.17. or PL 15.4.17
17	Verify the voltage between P/J83-11 <=> P/J81-1 on the Circuit Board LTA is +24 VDC.	Go to Step 18.	Replace the Lower Feeder Circuit Board, PL 14.5.1 or PL 15.5.1.
18	Check the OPT Feeder Plug Assembly to the LTA Main Assembly to the Tray 3 Harness Assembly for continuity. See "Paper Tray 3" on page 10-29.	Replace the Engine Control Board, page 8-107.	Replace the open Harness Assembly.

Misfeed at Tray 4: Jam T4

- Try feeding paper from another tray.
- Ensure that the paper path is free of obstructions and debris.
- Ensure that tray is installed correctly.
- Remove, fan, and reload the media in the tray.
- Ensure that the media in Tray 3 is a supported type and size.
- Cycle printer power.
- If the problem persists, follow the procedure below.

Troubleshooting Reference Table

Applicable Parts	Wiring and Plug/Jack Map References
Paper Pick Roller Kit, PL 14.4.3	“Paper Tray 4” on page 10-30
Paper Feed Roller Kit, PL 14.1.2	“Paper Feed” on page 10-25
HCF Paper Pick Assembly, PL 14.4.1	“Drive Section” on page 10-28

Troubleshooting Procedure Table

Steps	Actions and Questions	Yes	No
1	Does the printer feed paper correctly from Tray 2?	Go to Step 2.	See "Misfeed at Tray 2 Jam T2" on page 3-33.
2	Does the HCF Motor run when printing one sheet?	Go to Step 10.	Go to Step 3.
3	Use service diagnostics to test the HCF Motor. Does the HCF motor function correctly?	Replace the Engine Control Board, page 8-107.	Go to Step 4.
4	Verify the voltage between P/J84-3 <=> P/J81-1 on the Lower Feeder Circuit Board is +24 VDC	Go to Step 7.	Go to Step 5.
5	Verify the voltage between P/J81-2 <=> P/J81-1 on the Lower Feeder Circuit Board HCF is +24 VDC.	Replace the Lower Feeder Circuit Board, PL 14.5.1.	Go to Step 6
6	Verify the connector between the HCF and the printer is connected properly and not damaged.	Replace the damaged part.	Go to Step 7.
7	Does the error recur after the HCF Motor has been replaced with a new one?	Go to Step 8.	Complete

Troubleshooting Procedure Table (Continued)

Steps	Actions and Questions	Yes	No
8	Perform Steps 1 through 3 in page 8-113. Open and close the front door. Observe the Turn Roller. Does the Turn Roller turn while the machine is warming up?	Go to Step 12.	Go to Step 9.
9	Does the Tray 4 Turn Clutch Assembly function correctly when feeding 1 sheet of paper?	Go to Step 14.	Go to Step 10.
10	Use service diagnostics to test the Tray 4 Turn Clutch. Does the clutch function correctly?	Check the clutch for slip or the gears for damage.	Go to Step 11.
11	Verify the voltage between P/J83-13 <=> P/J81-1 on the Lower Feeder Circuit Board is +24 VDC.	Go to Step 12.	Replace the Lower Feeder Circuit Board, PL 14.5.1.
12	Check the Tray 4 Harness for continuity. See "Paper Tray 4" on page 10-30.	Go to Step 13.	Replace the Tray 4 Harness Assembly, PL 14.4.
13	Remove the Assembly, Clutch Turn Tray 4 connector J835. Is J835-1 <=> J835-2 less than 200 ohms?	Go to Step 14.	Replace the Tray 4 Turn Clutch Assembly, PL 14.4.18.
14	Does the Feed Gear in the Tray 4 Feeder turn when feeding 1 sheet of paper?	Check the Solenoid for damage.	Go to Step 16.
15	Use service diagnostics to test the Tray 4 Clutch Solenoid. Does the solenoid function correctly?	Check the stopper on the feed solenoid and replace, if necessary.	Go to Step 17.
16	Verify the voltage between P/J83-11 <=> P/J81-1 on the Lower Feeder Circuit Board is +24 VDC.	Go to Step 17.	Replace the Lower Feeder Circuit Board, PL 14.5.1.
17	Remove the Tray 4 Feed Solenoid connector J834. Is J834-1 <=> J834-2 less than 100 ohms?	Go to Step 18.	Replace the Tray 4 Feed Solenoid, PL 14.4.17.
18	Check the OPT Feeder Plug Assembly to the HCF Main Assembly to the Tray 4 Harness Assembly for continuity. See "Paper Tray 4" on page 10-30.	Replace the Engine Control Board, page 8-107.	Replace the open Harness Assembly.

Door and Cover Errors

Close Front Door

- Ensure that the front door is free of obstructions and fully closed.
- Verify that the interlock switch tab actuator is not broken.
- Cycle printer power.
- If the problem persists, follow the procedure below

Troubleshooting Reference Table

Applicable Parts	Wiring and Plug/Jack Map References
Front Cover, PL 1.1.2	“Main Wiring Diagram” on page 10-15
Motor Driver Board, PL 12.1.12	“Drive Section” on page 10-18

Troubleshooting Procedure Table

Steps	Actions and Questions	Yes	No
1	Check the following for evidence of fault or damage: <ul style="list-style-type: none">■ Motor Driver Board, PL 12.1.12■ Interlock Switch on Motor Driver Board■ Actuator tab on the Front Cover■ CAM I/R on the Top Imaging Unit Cover Acuator I/L, PL 11.1.8	Replace the parts concerned.	Go to Step 2.
2	Use service diagnostics to test the Interlock Switch. Does the Interlock Switch function correctly?	Replace Engine Control Board, page 8-107.	Go to Step 3.
3	Verify the voltage between P/J41-35 <=> P/J41-22 on the Motor Driver Board is 0 VDC. Close the Front Cover during the check.	Replace Engine Control Board, page 8-107.	Replace the Motor Driver Board, page 8-101.

Consumable Errors

Install or Reseat Imaging Unit

- Remove and reseat the Imaging Unit.
- Ensure that Door C is fully closed.
- Cycle printer power.
- If the problem persists, follow the procedure below

Troubleshooting Reference Table

Applicable Parts	Wiring and Plug/Jack Map References
Imaging Unit, PL 9.1.3	“Laser Unit” on page 10-22
	“Fuser Assembly” on page 10-21

Troubleshooting Procedure Table

Step	Actions and Questions	Yes	No
1	Remove the Imaging Unit. Inspect the printer cavity for damage, foreign material and loose toner under the auger area which could prevent the Imaging Unit from being seated properly. Is there foreign material or damage?	Remove foreign materials. Vacuum out loose toner if found.	Go to Step 2.
2	Inspect and reseat the Imaging Unit checking for possible defects or damage.	Replace the Imaging Unit, PL 9.1.3.	Go to Step 3.
3	Remove the left cover. Check the Gear Slide and the Rack V for damage or misalignment. See “Toner Cartridge Holder Unit Assembly (PL 10.1)” on page 8-77 for more information.	Damage can occur if the Gear and Rack are not in the proper position. With Door C open, push the Rack V up as far as it can go and then reinstall the gear slide.	Go to Step 4.
4	Verify the CRUM connector is not damaged or improperly connected.	Replace the Plate Dispenser Left, PL 10.1.9.	Go to Step 5.
5	Check the CRUM Harness for continuity. See “Laser Unit” on page 10-22.	Go to Step 6.	Replace CRUM Harness Assy, PL 10.1.15.
6	Check the EEPROM Harness for continuity. See “Laser Unit” on page 10-22	Replace the Engine Control Board, page 8-107.	Replace EEPROM Harness Assy, PL 13.1.10.

Replace Imaging Unit or Imaging Unit is Near End of Life

- Print the Supplies Usage page and verify life remaining and date Imaging Unit was installed.
- Cycle printer power.
- If the problem persists, follow the procedure below

Note

The “Imaging Unit is Near End of Life” is a warning. “Replace Imaging Unit” is a hard stop.

Troubleshooting Reference Table

Applicable Parts	Wiring and Plug/Jack Map References
Imaging Unit PL 9.1.3	“Laser Unit” on page 10-22

Troubleshooting Procedure Table

Steps	Actions and Questions	Yes	No
1	Check the following parts for evidence of fault or damage: Imaging Unit PL 9.1.3 CRUM Connector on the Plate Dispenser	Replace the parts concerned.	Go to Step 2.
2	Replace the Imaging Unit . Does the error recur?	Go to Step 3.	Complete
3	Verify the CRUM Harness is properly connected. See “Laser Unit” on page 10-22.	Go to Step 4.	Replace the CRUM Harness Assembly, PL 10.1.15.
4	Check CRUM Harness Assembly for continuity. See “Laser Unit” on page 10-22.	Go to Step. 5.	Replace the CRUM Harness Assembly, PL 10.1.15.
5	Check the EEPROM Harness for continuity. See “Fuser Assembly” on page 10-21.	Replace the Engine Control Board, page 8-107.	Replace EEPROM Harness Assembly, PL 13.1.10.

Install or Reset Transfer Roller

- Ensure the CTD (ADC) Sensor is clean.
- Ensure that the Transfer Roller Assembly is correctly installed.
- Cycle printer power.
- If the problem persists, follow the procedure below.

Troubleshooting Reference Table

Applicable Parts	Wiring and Plug/Jack Map References
CTD (ADC) Sensor Assembly , PL 5.1.11	“Xerographics 1” on page 10-23
Transfer Roller Assembly, PL 8.1.12	

Troubleshooting Procedure Table

Step	Actions and Questions	Yes	No
1	Check the following parts for damage and replace if defective: Transfer Roller PL 8.1.12 CTD (ADC) Sensor, PL 5.1.11	Complete	Go to Step 2.
2	Clean the CTD (ADC) Sensor to remove any toner build up. Does this fix the problem?	Complete	Go to Step 3.
3	Use service diagnostics to test the CTD (ADC) Sensor. Does the sensor function correctly?	Go to Step 4.	Go to Step 5.
4	Replace the Transfer Roller. Does the error recur?	Go to Step 5.	Complete
5	Is the CTD (ADC) Harness connected to the CTD (ADC) Sensor correctly?	Go to Step 6.	Connect properly
6	Check J 136 <=> J 1361 on the CTD (ADC) Harness for continuity.	Go to Step 7.	Replace the CTD (ADC) Harness, RRP 5.2.
7	Check J 1361 <=> J 13 on the Front 1A Harness for continuity.	Go to Step 8.	Replace the Front 1A Harness Assembly, PL 13.1.7.
8	Verify the voltage between P/J136-5 <=> P/J136-3 on the Front 1A Harness Assembly is 0 VDC.	Replace the CTD (ADC) Sensor, page 8-42.	Replace the Engine Control Board, page 8-107.

Replace Transfer Roller or Transfer Roller is at End of Life

- Print the Supplies Usage page to verify the remaining life and Transfer Roller install date.
- Cycle printer power.
- If the problem persists, follow the procedure below

Note

Look at the clear plastic window on the Transfer Roller. If toner is present in the center of the window the Transfer Roller is at end of life and needs to be replaced. If no toner is visible, try cleaning the CTD (ADC) Sensor.

The “Transfer Roller is at End of Life” is a warning. “Replace Transfer Roller” is a hard stop.

Troubleshooting Reference Table

Applicable Parts	Wiring and Plug/Jack Map References
Toner Full Sensor, PL 5.1.13	“Xerographics 1” on page 10-23

Troubleshooting Procedure Table

Steps	Actions and Questions	Yes	No
1	Check the following for evidence of fault or damage: Transfer Roller PL 8.1.12 Toner Full Sensor PL 5.1.13	Replace the parts concerned.	Go to Step 2.
2	Use service diagnostics to test the Transfer Roller Toner Full Sensor. Does the Transfer Roller Toner Full Sensor function correctly?	Replace the Engine Control, Board, page 8-107.	Go to Step 3.
3	Remove the Transfer Roller Assembly. Verify the voltage between P/J141-2 <=> P/J141-1 on the Transfer Roller Toner Full Sensor Harness is 0 VDC.	Go to Step 5.	Go to Step 4.
4	Verify the voltage between P/J141-3 <=> P/J141-1 on the Transfer Roller Toner Full Sensor Harness is + 5 VDC.	Go to Step 5.	Replace Assy, Harness EEPROM PL 13.1
5	Check the Transfer Roller Toner Full Sensor Harness for continuity. See “Xerographics 1” on page 10-23.	Replace the Toner Full Sensor, page 8-43.	Replace the Toner Full Sensor Harness, page 8-43.

Install or Reseat Fuser

- Ensure that the Fuser is fully seated.
- Ensure that the Fuser latches are in the fully latched position.
- Cycle printer power.
- If the problem persists, follow the procedure below.

Troubleshooting Reference Table

Applicable Parts	Wiring and Plug/Jack Map References
Fuser Harness (FSR 4), PL 5.1.9	"Fuser Assembly" on page 10-21

Warning

To avoid the potential of electric shock, ensure the power to the printer is off and the power cord is disconnected from the wall outlet prior to performing Step 2 in the following troubleshooting procedure..

Troubleshooting Procedure Table

Steps	Actions and Questions	Yes	No
1	Cycle power to the printer. Does the error recur?	Go to Step 2.	Complete
2	Check the Fuser Assembly for fault or damage.	Replace the Fuser Assembly, PL 8.1.1 Power cycle the printer after replacing the Fuser.	Go to Step 3.
3	Does the error recur after replacing the Fuser Assembly?	Go to Step 4.	Complete
4	Check the Fuser Harness (FSR4) for continuity. See "Fuser Assembly" on page 10-21.	Go to Step 5.	Replace the Fuser Harness, FSR 4 PL 5.1.9.
5	Check the FRONT 1A Harness for continuity. See "Fuser Assembly" on page 10-21.	Replace the Engine Control Board, page 8-107.	Replace the FRONT 1A Harness Assembly, PL 13.1.7.

Replace Fuser or Fuser is Near End of Life

- Print the Supplies Usage page to verify remaining life and Fuser install date.
- Cycle printer power.
- If the problem persists, follow the procedure below

Note

The “Fuser is Near End of Life” is a warning. “Replace Fuser” is a hard stop.

Troubleshooting Reference Table

Applicable Parts	Wiring and Plug/Jack Map References
EEPROM Board, PL 10.1.16	“Laser Unit” on page 10-22
CRUM Harness Assembly, PL 10.1.15	“Fuser Assembly” on page 10-21

Warning

To avoid the potential of electric shock, ensure the power to the printer is off and the power cord is disconnected from the wall outlet prior to performing Step 1 in the following troubleshooting procedure..

Troubleshooting Procedure Table

Steps	Actions and Questions	Yes	No
1	Check the connector to the Fuser Assembly for damage.	Connect properly or replace the parts concerned. Power cycle the printer.	Go to Step 2.
2	Does the error recur after the Fuser has been replaced with a new one?	Go to Step 3.	Complete
3	Replace the EEPROM Board. Does the error recur?	Troubleshoot using the wiring diagram “Fuser Assembly” on page 10-21 Replace the Engine Control Board, page 8-107.	Complete

Install or Lock [Y] [M] [C] [K] Toner Cartridge

- Ensure that the Toner Cartridges are fully seated and locked into position.
- Ensure that all ribbon tape has been removed from the cartridges.
- Cycle printer power.
- If the problem persists, follow the procedure below

Note

Follow this troubleshooting procedure using the Y, M, C or K Steps as appropriate for the color indicated by the front panel error message.

Troubleshooting Reference Table

Applicable Parts	Wiring and Plug/Jack Map References
Toner Present Switch Actuator, PL 10.1.22	“Developer Section 1” on page 10-19
Toner Present Sensor Bracket, PL 10.1.6	“Developer Section 1” on page 10-19

Troubleshooting Procedure Table

Step	Actions and Questions	Yes	No
1	Use service diagnostic to test the toner present switch of the problem color. Does the Toner Present Switch (YMCK) function normally?	Replace the Engine Control Board, page 8-107.	Go to Step 2.
2	Check the following for evidence of fault or damage, replace the assembly if defective: Toner Present Sensor Bracket (YMCK), PL 10.1.6. Toner Present Switch Actuator (YMCK), PL 10.1.22.	Complete	Go to Step 3.
3	Check the output of the pertinent color from the Motor Driver Board P/J51-13PIN <=> P/J51-14, 15, 16, or 17PIN for 0V DC.	Go to Step 7.	Go to Step 4.
4	Check the output of the pertinent color from the CRUM Reader Board P/J342-5PIN <=> P/J342-1, 2, 3, or 4PIN for 0VDC.	Go to Step 6.	Go to Step 5.

Troubleshooting Procedure Table

Step	Actions and Questions	Yes	No
5	Check the pertinent color's switch on the CRUM Reader Board P/J342-5PIN <=> P/J342-1, 2, 3, or 4PIN for continuity. Depressing the switch should change its logic state.	Go to Step 6.	Replace Box Assy, CRUM Reader, page 8-85
6	Check the Harness Assembly TNR4 J51 <=> J342 for continuity.	Go to Step 7.	Replace Harness Assy TNR4 PL 10.1.11.
7	Check the output for the pertinent color from the Motor Driver Board P/J42-3, 4, 5, or 6 PIN <=> P/J42-14 PIN for 0VDC.	Go to Step 8.	Replace the Motor Driver Board, page 8-101.
8	Check the output for the pertinent color from the Engine Control Board P/J12-25, 26, 27, or 28 PIN <=> P/J12-17 PIN for 0VDC.	Replace the Engine Control Board, page 8-107.	Go to Step 9.
9	Check the harness Assembly DRV2-2 J12 <=> J42 for continuity.	Replace the Engine Control Board, page 8-107.	Replace the Harness Assy DRV2-2, PL 13.1.3.

Replace [Y] [M] [C] [K] Toner Cartridge or [Y] [M] [C] [K] Toner Is Low

- Print the Supplies Usage page to verify remaining life and Toner Cartridge install date.
- Replace the cartridge.
- Cycle printer power.
- If the problem persists, follow the procedure below

Note

“[Y] [M] [C] [K] Toner Is Low” is a warning condition. “Replace [Y] [M] [C] [K] Toner Cartridge” is a hard stop error condition.

An empty cartridge or a fatal error within the cartridge or printer can cause the hard stop condition. Check for an error code in the help text prior to troubleshooting this error message. If a code is present in the help text, go to the fatal error troubleshooting procedure for "Replace [Y] [M] [C] [K] Toner Cartridge" on page 3-81.

When no jobs are being sent to the printer, an additional low toner warning message “[Y] [M] [C] [K] Toner Cartridge Empty” will be displayed on the front panel. This allows continued printing (Run Black) in black and white mode for a short period of time. Once the color cartridges are empty, the message changes to “Replace [Y] [M] [C] [K] Toner Cartridge”, a hard stop.

Troubleshooting Reference Table

Applicable Parts	Wiring and Plug/Jack Map References
Toner Low Sensor, PL 10.1.5	“Developer Section 1” on page 10-19
Motor Driver Board, PL 12.1.14	“Drive Section” on page 10-18
Toner Cartridge Holder Assembly, PL 10.1	

Troubleshooting Procedure Table

Steps	Actions and Questions	Yes	No
1	Verify replacement of the Toner Cartridge for the problem color. Does the error recur after the toner cartridge is replaced?	Go to Step 2.	Complete

Troubleshooting Procedure Table (Continued)

Steps	Actions and Questions	Yes	No
2	Use service diagnostics to test the Toner Low Sensor. If the test fails check the sensor connector, if the connector is ok replace the Toner Low Sensor for the problem color. Does the error recur?	Go to Step 3.	Complete
3	Use service diagnostics to test the Toner Motor. Caution: Run this test for ONLY 5 seconds to avoid packing the toner. Does the Toner Motor function correctly?	Check the toner stirring auger or gear for damage.	Go to Step 4.
4	Replace the Toner Motor. Does this fix the problem?	Complete	Go to Step 5.
5	Verify the auger tube of the problem color is full of toner near the hopper end.	Go to Step 6.	Inspect the toner cartridge for dispense problems.
6	Verify that the voltage between P/J 51-21 <=> P/J 60-2 on the Motor Driver Board is 24 VDC	Go to Step 7.	Replace the Motor Driver Board, page 8-101
7	Troubleshoot using the wiring diagrams: See "Developer Section 1" on page 10-19. and See "Drive Section" on page 10-18. Replace any defective parts. Does the error still appear?	Replace the Engine Control Board, page 8-107.	Complete

Dusty Density Sensor

- Cycle printer power.
- If the problem persists, follow the procedure below

Troubleshooting Reference Table

Applicable Parts	Wiring and Plug/Jack Map References
CTD (ADC) Sensor Assembly , PL 5.1.11	“Xerographics 1” on page 10-23

Troubleshooting Procedure Table

Steps	Actions and Questions	Yes	No
1	Clean the CTD Sensor to remove any toner build up. Does this fix the problem?	Complete	Go to Step 2.
2	Check the following for evidence of fault or damage: Transfer Roller Assembly, PL 8.1.12 CTD (ADC) Sensor Assembly , PL 5.1.11	Replace the parts concerned.	Go to Step 3.
3	Is the CTD (ADC) Harness properly connected to the CTD (ADC) Sensor?	Go to Step 4.	Reconnect or replace the parts concerned.
4	Replace the CTD (ADC) Sensor. Does the error still appear after replacing the sensor?	Go to Step 5.	Complete
5	Check the CTD (ADC) Harness for continuity. See “Xerographics 1” on page 10-23.	Go to Step 6.	Replace the CTD (ADC) Harness Assembly, PL 5.1.10.
6	Check the Harness Assembly Front 1A for continuity. See “Xerographics 1” on page 10-23.	Replace Engine Control Board, page 8-107.	Replace Harness Assembly Front 1A, PL 13.1.7.

Output Tray is Full, Unload Paper

- Ensure that the output tray is empty.
- Ensure that the output tray full flag is in the correct position.
- Cycle printer power.
- If the problem persists, follow the procedure below.

Troubleshooting Reference Table

Applicable Parts	Wiring and Plug/Jack Map References
Actuator Kit, PL 6.1.5	“Paper Feed” on page 10-25
Full Stack Sensor, PL 6.1.4	“Paper Feed” on page 10-25

Troubleshooting Procedure Table

Steps	Actions and Questions	Yes	No
1	Check the following for evidence of fault or damage: Actuator, Full Stack PL 6.1.5 Full Stack Sensor PL 6.1.4	Replace the parts concerned.	Go to Step 2.
2	Use service diagnostics to test the Full Stack Sensor. Does the sensor function correctly?	Replace Engine Control Board, page 8-107	Go to Step 3.
3	Replace the Full Stack Sensor. Does the sensor report an error once replaced?	Go to Step 4.	Complete
4	Troubleshoot the wiring using the wiring diagram “Paper Feed” on page 10-25.	Replace defective parts.	Replace Engine Control Board, page 8-107.

Remove Ribbon from [Y] [M] [C] [K] Toner Cartridge

- Remove the Toner Cartridge and ensure that the ribbon tape has been completely removed.
- Inspect the mouth of the toner auger for obstructions or debris.
- Cycle printer power.
- If the problem persists, follow the procedure below

Troubleshooting Reference Table

Applicable Parts	Wiring and Plug/Jack Map References
Pertinent Toner Cartridge, PL 10.1.7, 8, 9, or 10	

Troubleshooting Procedure Table

Steps	Actions and Questions	Yes	No
1	Has the shipping ribbon been removed from the Toner Cartridge?	Go to Step 2.	Remove the ribbon and power cycle the printer.
2	Does the error clear after Door A is opened and closed?	Complete	Refer to “[Y] [M] [C] [K] Toner Cartridge Is Low” troubleshooting procedure page 3-50.

Tray and Media Errors

Insert Tray [2] or Tray [2] Missing

- Remove Tray 2 and inspect the tray cavity of the printer to ensure that it is free of obstructions or debris.
- Reinstall the tray.
- Cycle printer power.
- If the problem persists, follow the procedure below.

Troubleshooting Reference Table

Applicable Parts	Wiring and Plug/Jack Map References
Paper Size Switch Assembly, PL 3.2.4	"Paper Tray 2" on page 10-17

Troubleshooting Procedure Table

Steps	Actions and Questions	Yes	No
1	Check the following for evidence of fault or damage: Paper Size Switch Tray [2], PL 3.2.4 Actuators on the right side of Tray [2]	Replace the parts concerned.	Go to Step 2.
2	Use service diagnostics to test the Tray [2] Paper Size Switches. Use the table below for reference. Do the switches function correctly?	Replace Engine Control Board, page 8-107.	Go to Step 3.
3	Verify the pertinent voltages on pins P/J47 – 1 <=> P/J47 – 3 P/J47 – 2 <=> P/J47 – 3 P/J47 – 4 <=> P/J47 – 3 Correspond to the paper size switch position chart below.	Go to Step 4	Replace the Paper Size Switch page 8-26.
4	Verify the pertinent voltages on pins P/J42 – 16 <=> P/J42-15 P/J42-17 <=> P/J42-15 P/J42-18 <=> P/J42-15 Correspond to the paper size switch position chart below.	Replace Engine Control Board, page 8-107	Replace the Motor Driver Board page 8-101.

Paper Size Switches are indicated as SW1, SW2, and SW3

Paper Size	Paper Size Switch		
	SW1	SW2	SW3
LEGAL14"	ON	ON	ON
LEGAL13"	ON	ON	OFF
EXECUTIVE	ON	OFF	ON
B5	ON	OFF	OFF
A4	OFF	ON	ON
A5 (Provided for reference only. Supported by Tray 1 (MPT) only.)	OFF	ON	OFF
A	OFF	OFF	ON
No Tray	OFF	OFF	OFF

Insert Tray [3] [4] or Tray [3] [4] Missing

- Remove Tray [3] [4] and inspect the tray cavity of the printer to ensure that it is free of obstructions or debris.
- Reinstall the tray.
- Cycle printer power.
- If the problem persists, follow the procedure below.

Note

Paper Tray 3 can refer to either the High Capacity Feeder (HCF) or 500-sheet Feeder. Part list and page references are provided for both units.

Troubleshooting Reference Table

Applicable Parts	Wiring and Plug/Jack Map References
Paper Size Switch Assembly, PL 14.3.6 or PL 15.3.6	“Paper Tray 3” on page 10-29 or page 10-33
	“Paper Tray 4” on page 10-30

Troubleshooting Procedure Table

Steps	Actions and Questions	Yes	No
1	Check the following for evidence of fault or damage: Paper Size Switch Tray [3] [4], PL 14.3.6 or PL 15.3.6 Actuators on the right side of the Tray	Replace the parts concerned.	Go to Step 2.
2	Use service diagnostics to test the Tray [3] [4] Paper Size Switches. Use the table below for reference. Do the switches function correctly?	Replace Engine Control Board, page 8-107.	Go to Step 3.
3	Verify the pertinent Tray 3 voltages on pins: P/J82 – 1 <=> P/J47 – 3 P/J82 – 2 <=> P/J47 – 3 P/J82 – 4 <=> P/J47 – 3 Or Tray 4 voltages on pins: P/J83 – 1 <=> P/J47 – 3 P/J83 – 2 <=> P/J47 – 3 P/J83 – 4 <=> P/J47 – 3 of the Lower Feeder Circuit Board, PL 14.5.1 or PL 15.5.1, correspond to the paper size switch position chart below.	Go to Step 4.	Replace the Paper Size Switch page 8-128 or page 8-146

Troubleshooting Procedure Table

Steps	Actions and Questions	Yes	No
4	Verify the pertinent Tray 3 voltages on pins: P/J81 – 11 <=> P/J47 – 23 P/J81 – 12 <=> P/J47 – 23 P/J81 – 13 <=> P/J47 – 23 Or Tray 4 voltages on pins: P/J81 – 8 <=> P/J47 – 23 P/J81 – 9 <=> P/J47 – 23 P/J81 – 10 <=> P/J47 – 23 of the Lower Feeder Circuit Board, PL 14.5.1 or PL 15.5.1, correspond to the paper size switch position chart below		Replace the Circuit Board, Lower Feeder page 8-116 or page 8-135
5	Check the OPT Feeder Plug PL 14.5.2 or PL 15.5.2, Harness Assy, Tray 3 PL 14.5.3 or PL 15.5.3, and Harness Assy, Tray 4 PL 14.5.6 for continuity.	Replace Engine Control Board, page 8-107.	Replace the affected Harness Assy.

Paper Size Switches are indicated as SW1, SW2, and SW3

Paper Size	Paper Size Switch		
	SW1	SW2	SW3
LEGAL14"	ON	ON	ON
LEGAL13"	ON	ON	OFF
EXECUTIVE	ON	OFF	ON
B5	ON	OFF	OFF
A4	OFF	ON	ON
A5 (Provided for reference only. Supported by Tray 1 (MPT) only.)	OFF	ON	OFF
A	OFF	OFF	ON
No Tray	OFF	OFF	OFF

Tray 2 Paper is Low

- Remove Tray 2 and ensure that it is at least half full of paper.
- Inspect the tray for obstructions or defects.
- Reinstall the tray.
- Cycle printer power.
- If the problem persists, follow the procedure below.

Troubleshooting Reference Table

Applicable Parts	Wiring and Plug/Jack Map References
Low Paper Sensor, PL 3.3.4	“Paper Tray 2” on page 10-17
Low Paper Lever, PL 3.2.7	

Troubleshooting Procedures Table

Steps	Actions and Questions	Yes	No
1	Fill the tray with paper. Does the error occur if the tray is full?	Go to Step [2].	Complete
2	Check the following for evidence of fault or damage: Low Paper Sensor; PL 3.3.4 Low Paper Lever, PL 3.2.7	Replace the parts concerned.	Go to Step 3.
3	Use service diagnostics to test the Tray 2 Low Paper Sensor. Do the sensor and actuator function properly?	Replace the Engine Control Board, page 8-107.	Go to Step 4.
4	Verify the voltage between pins P/J 47-10 <=> P/J 47-9 on the Motor Driver Board is +3.3 VDC.	Go to Step 6.	Go to Step 5.
5	Verify the voltage between pins P/J 42-20 <=> P/J 42-15 on the Motor Driver Board is +3.3 VDC.	Replace the Motor Driver Board, page 8-101.	Replace the Engine Control Board, page 8-107.
6	Verify the voltage between pins P/J 47-8 <=> P/J 47-9 on the Motor Driver Board is +3.3 VDC.	Replace the Sensor No Paper, page 8-30.	Replace the Motor Driver Board, page 8-101.

Tray [3] [4] Paper is Low

- Remove Tray [3] [4] and ensure that it is at least half full of paper.
- Inspect the tray for obstructions or defects.
- Reinstall the tray.
- Cycle printer power.
- If the problem persists, follow the procedure below.

Note

Paper Tray 3 can refer to either the High Capacity Feeder (HCF) or 500-sheet Feeder. Part list and page references are provided for both units.

In the following procedures, diagnose the part that correlates directly to the Tray receiving the error.

Troubleshooting Reference Table

Applicable Parts	Wiring and Plug/Jack Map References
Low Paper Sensor, PL 14.5.7 or PL 15.5.7	"Paper Tray 3" on page 10-29 or page 10-33
Low Paper Lever, PL 14.5.8 or PL 15.5.8	"Paper Tray 4" on page 10-30

Troubleshooting Procedures Table

Steps	Actions and Questions	Yes	No
1	Fill the tray with paper. Does the error occur if the tray is full?	Go to Step 2.	Complete
2	Check the following for evidence of fault or damage: Low Paper Sensor; PL 14.5.7 or 15.5.7 Low Paper Lever, PL 14.5.8 or 15.5.8	Replace the parts concerned	Go to Step 3.
3	Use service diagnostics to test the Tray [3] [4] Low Paper Sensor. Do the sensor and actuator function properly?	Replace the Engine Control Board, page 8-107.	Go to Step 4.
4	Does the printer function correctly after replacing the Circuit Board, Lower Feeder?	Complete	Go to Step 5.
5	Troubleshoot using the Paper Tray [3] [4] wiring diagrams. Does the printer function correctly after replacing any defective parts?	Complete	Replace the Engine Control Board, page 8-107.

Out of Paper; Load Tray 1 (MPT) with [size] [type]

- Remove Tray 1 and inspect the tray cavity of the printer to ensure that it is free of obstructions or debris.
- Ensure that the tray is loaded with supported media.
- Ensure that the media guides are properly adjusted.
- Reinstall the tray.
- Cycle printer power.
- If the problem persists, follow the procedure below.

Troubleshooting Reference Table

Applicable Parts	Wiring and Plug/Jack Map References
MPT No Paper Sensor, PL 6.1.4	“Paper Feed” on page 10-25
MPT actuator, PL 6.1.37	

Troubleshooting Procedure Table

Steps	Actions and Questions	Yes	No
1	Fill Tray 1 (MPT) with paper. Does the error occur even if Tray 1 is full?	Go to Step 2.	Complete.
2	Check the following for evidence of fault or damage: MPT No Paper Sensor, PL 6.1.4 MPT actuator, PL 6.1.37	Replace the parts concerned.	Go to Step 3.
3	Use service diagnostics to test the MPT No Paper Sensor Does the Sensor function correctly?	Replace the Engine Control Board, page 8-107	Go to Step 4.
4	Replace the MPT No Paper Sensor. Does the error recur after the sensor is replaced?	Go to Step 5.	Complete.
5	Troubleshoot using the wiring diagram “Paper Feed” on page 10-25. Does the problem recur after any defective parts are replaced?	Replace the Engine Control Board, page 8-107	Complete

Out of Paper; Load Tray [2] [3] [4] with [size] [type]

- Remove Tray [2] [3] [4] and inspect the tray cavity of the printer to ensure that it is free of obstructions or debris.
- Ensure that the tray is loaded with supported media.
- Ensure that the media guides are properly adjusted.
- Reinstall the tray.
- Cycle printer power.
- If the problem persists, follow the procedure below.

Troubleshooting Reference Table

Applicable Parts	Wiring and Plug/Jack Map References
No Paper Sensor, PL 3.3.4 (Tray 2) PL 14.4.4 or 15.4.4 Trays 3 & 4)	“Paper Tray 2” on page 10-17, “Paper Tray 3” on page 10-29, or page 10-33 “Paper Tray 4” on page 10-30
Link Actuator, PL 3.3.6 (Tray 2) PL 14.4.6 or 15.4.6 Trays 3 & 4)	
No Paper Actuator PL 3.3.5 (Tray 2) PL 14.4.5 or 15.4.5 Trays 3 & 4)	

Troubleshooting Procedure Table

Steps	Actions and Questions	Yes	No
1	Fill Tray. Does the error occur even if the tray is full?	Go to Step [2].	Complete
2	Check the following for evidence of fault or damage: No Paper Sensor, PL 3.3.4 (PL 14.4.4 or PL 15.4.4) No Paper Actuator, PL 3.3.5 (PL 14.4.5 or PL 15.4.5)	Replace the parts concerned.	Go to Step 3.
3	Use service diagnostics to test the Tray No Paper Sensor. Does the sensor function correctly?	Replace Engine Control Board, page 8-107.	Go to Step 4.
4	Does the printer function correctly after replacing the Engine Control Board?	Complete	Go to Step 5.
5	Troubleshoot using the wiring diagram “Paper Tray 2” on page 10-17, “Paper Tray 3” on page 10-29 or page 10-33, “Paper Tray 4” on page 10-30. Does the printer function correctly after replacing any defective parts?	Complete	Replace the Engine Control Board, page 8-107.

Wrong Paper Size; Load Tray 2 with [size] [type]

- Remove Tray 2 and inspect the tray cavity of the printer to ensure that it is free of obstructions or debris.
- Ensure that the tray is loaded with supported media.
- Ensure that the media guides are properly adjusted.
- Reinstall the tray.
- Cycle printer power.
- If the problem persists, follow the procedure below.

Note

This is a media SIZE mismatch error.

Troubleshooting Reference Table

Applicable Parts	Wiring and Plug/Jack Map References
Paper Size Switch Assembly, PL 3.2.4	“Paper Tray 2” on page 10-17

Troubleshooting Procedure Table

Steps	Actions and Questions	Yes	No
1	Check the following for evidence of fault or damage: Paper Size Switch Tray [2], PL 3.2.4 Actuators on the right side of Tray [2]	Replace the parts concerned.	Go to Step 2.
2	Use service diagnostics to test the Tray [2] Paper Size Switches. Use the table below for reference. Do the switches function correctly?	Replace Engine Control Board, page 8-107.	Go to Step 4.
3	Does the printer function correctly after replacing the Engine Control Board?	Complete	Go to Step 4.
4	Verify the pertinent voltages on pins P/J47 – 1 <=> P/J47 – 3 P/J47 – 2 <=> P/J47 – 3 P/J47 – 4 <=> P/J47 – 3 Correspond to the paper size switch position chart below.	Go to Step 5.	Replace the Paper Size Switch page 8-26.

Troubleshooting Procedure Table

Steps	Actions and Questions	Yes	No
5	Verify the pertinent voltages on pins P/J42 – 16 <=> P/J42-15 P/J42-17 <=> P/J42-15 P/J42-18 <=> P/J42-15 Correspond to the paper size switch position chart below.	Replace Engine Control Board, page 8-107	Replace the Motor Driver Board page 8-101.

Paper Size Switches are indicated as SW1, SW2, and SW3

Paper Size	Paper Size Switch		
	SW1	SW2	SW3
LEGAL14"	ON	ON	ON
LEGAL13"	ON	ON	OFF
EXECUTIVE	ON	OFF	ON
B5	ON	OFF	OFF
A4	OFF	ON	ON
A5 (Provided for reference only. Supported by Tray 1 (MPT) only.)	OFF	ON	OFF
A	OFF	OFF	ON
No Tray	OFF	OFF	OFF

Wrong Paper Size; Load Tray [3] [4] with [size] [type]

- Remove Tray [3] [4] and inspect the tray cavity of the printer to ensure that it is free of obstructions or debris.
- Ensure that the tray is loaded with supported media.
- Ensure that the media guides are properly adjusted.
- Reinstall the tray.
- Cycle printer power.
- If the problem persists, follow the procedure below.

Note

This is a media SIZE mismatch error.

Troubleshooting Reference Table

Applicable Parts	Wiring and Plug/Jack Map References
Paper Size Switch Tray [3] [4] PL 14.3.6 or 15.3.6	“Paper Tray 3” on page 10-29 or page 10-33 and “Paper Tray 4” on page 10-30

Troubleshooting Procedure Table

Steps	Actions and Questions	Yes	No
1	Check the following for evidence of fault or damage: Paper Size Switch Tray [3] [4], PL 14.3.6 or 15.3.6 Actuators on the right side of the Tray	Replace the parts concerned.	Go to Step 2.
2	Use service diagnostics to test the Tray [3] [4] Paper Size Switches. Use the table below for reference. Do the switches function correctly?	Replace Engine Control Board, page 8-107.	Go to Step 4.
3	Does the printer function correctly after replacing the Engine Control Board?	Complete	Go to Step 4.
4	Verify the pertinent Tray 3 voltages on pins: P/J82 – 1 <=> P/J47 – 3 P/J82 – 2 <=> P/J47 – 3 P/J82 – 4 <=> P/J47 – 3 Or Tray 4 voltages on pins: P/J83 – 1 <=> P/J47 – 3 P/J83 – 2 <=> P/J47 – 3 P/J83 – 4 <=> P/J47 – 3 of the Lower Feeder Circuit Board, PL 14.5.1 or 15.5.1, correspond to the paper size switch position chart below.	Go to Step 5.	Replace the Paper Size Switch page 8-128 or page 8-146

Troubleshooting Procedure Table (Continued)

Steps	Actions and Questions	Yes	No
5	Verify the pertinent Tray 3 voltages on pins: P/J81 – 11 <=> P/J47 – 23 P/J81 – 12 <=> P/J47 – 23 P/J81 – 13 <=> P/J47 – 23 Or Tray 4 voltages on pins: P/J81 – 8 <=> P/J47 – 23 P/J81 – 9 <=> P/J47 – 23 P/J81 – 10 <=> P/J47 – 23 of the Lower Feeder Circuit Board, PL 14.5.1 or 15.5.1, correspond to the paper size switch position chart below.	Go to Step 6.	Replace the Circuit Board, Lower Feeder page 8-116 or page 8-135.
6	Check the OPT Feeder Plug PL 14.5.2, or 15.5.2 Harness Assy, Tray 3 PL 14.5.3 or 15.5.3, and Harness Assy, Tray 4 PL 14.5.6 for continuity.	Replace Engine Control Board, page 8-107.	Replace the affected Harness Assy.

Paper Size Switches are indicated as SW1, SW2, and SW3

Paper Size	Paper Size Switch		
	SW1	SW2	SW3
LEGAL14"	ON	ON	ON
LEGAL13"	ON	ON	OFF
EXECUTIVE	ON	OFF	ON
B5	ON	OFF	OFF
A4	OFF	ON	ON
A5 (Provided for reference only. Supported by Tray 1 (MPT) only.)	OFF	ON	OFF
A	OFF	OFF	ON
No Tray	OFF	OFF	OFF

Wrong Paper Type; Load Tray [1 (MPT)] [2] [3] [4] with [size] [type]

- Remove tray and inspect the tray cavity of the printer to ensure that it is free of obstructions or debris.
- Ensure that the tray is loaded with supported media.
- Reinstall the tray.
- Cycle printer power.
- If the problem persists, follow the procedure below

Note

This is a media TYPE mismatch error indicating an OHP Sensor malfunction.

Troubleshooting Reference Table

Applicable Parts	Wiring and Plug/Jack Map References
OHP Sensor Kit PL 9.1.12	“Paper Feed” on page 10-25

Troubleshooting Procedure Table

Steps	Actions and Questions	Yes	No
1	Check the following for evidence of fault or damage: OHP Sensor and Harness PL 9.1.12 Chute Assembly Registration PL 9.1.6 Replace parts as required .	OHP Sensor and Harness page 8-75. Assembly, Chute Registration page 8-71	Go to Step 3.
2	Does printer function correctly?	Complete	Go to Step 3.
3	Using service diagnostics, test the OHP Sensor. Does the OHP Sensor function correctly?	Replace Engine Control Board, page 8-107.	Go to Step 5.
4	Does printer function correctly?	Complete	Go to Step 5.
5	Check voltage between P/J32-2 <=> P/J32-1 on Engine Control Board is 0VDC.	Go to Step 6.	Go to Step 8.
6	Block the OHP Sensor. Has P/J32-2 <=> P/J32-1 changed from 0 VDC to +3.3 VDC?	Replace Engine Control Board, page 8-107.	Go to Step 8.
7	Does printer function correctly?	Complete	Go to Step 8.
8	Verify the voltage between P/J32-3 <=> P/J32-1 on the Engine Control Board is +5 VDC.	Replace the OHP Sensor, page 8-75.	Replace Engine Control Board, page 8-107.

Fatal Errors

Laser Failure

Code 07: Laser power has failed

Code 08: SOS (start of scan) failure 1

Code 09: SOS failure 2

Code 10: Warm up failure

Code 11: This is the generic laser fault used by the engine if a lower level error cannot be reported to the controller.

Troubleshooting Reference Table

Applicable Parts	Wiring and Plug/Jack Map References
Laser Unit, PL 9.1.1	"Laser Unit" on page 10-22

Troubleshooting Procedure Table

Steps	Actions and Questions	Yes	No
1	Check and reseal P/J151 on the Laser Unit. Does the printer function correctly if the harness is reseated?	Complete	Go to Step 2.
2	Replace the Laser Unit. Does the error recur after the Laser Unit has been replaced?	Go to Step 3.	Complete
3	Check the Laser Harness for continuity or damage. See the wiring diagram "Laser Unit" on page 10-22.	Replace the (ROSKA) Harness Assembly, PL 13.1.5.	Replace the Engine Control Board, page 8-107.

Density Sensor Failure

Code 13: Density Sensor Failure.

Code 14: Density Limit Over Output.

Code15: Density Limit.

Code 16: This is a generic density sensor error that is generated when a code 13, 14 or 15 is not specifically triggered.

Troubleshooting Reference Table

Applicable Parts	Wiring and Plug/Jack Map References
CTD (ADC) Sensor Assembly , PL 5.1.11	“Xerographics 1” on page 10-23

Troubleshooting Procedure Table

Steps	Actions and Questions	Yes	No
1	Clean the CTD (ADC) Sensor to remove any toner build up. Does this fix the problem?	Complete	Go to Step 2.
2	Use service diagnostics to test the CTD (ADC) Sensor. Does the sensor function correctly?	Go to Step 4.	Go to Step 3.
3	Replace the CTD (ADC) Sensor, see page 8-42. Does the error recur after the CTD (ADC) Sensor has been replaced?	Go to Step 4.	Complete
4	Check the CTD (ADC) Harness for continuity: See “Xerographics 1” on page 10-23.	Go to Step 5.	Replace the CTD (ADC) Harness Assembly PL 5.1.10.
5	Check the Harness Assembly Front 1A for continuity. See “Xerographics 1” on page 10-23.	Replace the Engine Control Board, page 8-107.	Replace the Harness Assembly Front 1A PL 13.1.7.

Fuser Failure

Code 40: The temperature sensor sensed an overheat condition.

Code 41: The temperature sensor sensed a low temperature condition.

Code 42: Temperature sensor not providing an output.

Code 43: Warm up failure, the temperature sensor does not detect the correct temperature within 60.4 seconds after the fuser lamp has been turned on.

Troubleshooting Reference Table

Applicable Parts	Wiring and Plug/Jack Map References
Low-Voltage Power Supply, PL 12.1.10	"Fuser Assembly" on page 10-21
FSR 2 Harness Assembly, PL 5.1.9	

Warning

To avoid the potential of electric shock, ensure the power to the printer is off and the power cord is disconnected from the wall outlet prior to performing Step 2 of the following troubleshooting procedure..

Troubleshooting Procedure Table

Steps	Actions and Questions	Yes	No
1	Ensure the correct Fuser (110v/220v) is installed in the printer, verify against the label on the Fuser Assembly. Check the Fuser Assembly for evidence of fault or damage.	Replace the parts concerned.	Go to Step 2.
2	Remove the Fuser Assembly and check for broken or bent pins.	Replace the parts concerned.	Go to Step 3.
3	Does the error recur after the Fuser Assembly has been replaced with a new one?	Go to Step 4.	Complete
4	Replace the Low-Voltage Power Supply, page 8-99. Does the error recur after the LVPS has been replaced?	Go to Step 5.	Complete
5	Check the Fuser Harness for continuity. See the wiring diagram "Fuser Assembly" on page 10-21.	Go to Step 6.	Replace the Fuser Harness, FSR 2 PL 5.1.9.
6	Check the Front 1A Harness for continuity. See the wiring diagram "Fuser Assembly" on page 10-21.	Replace the Engine Control Board, page 8-107.	Replace Front 1A Harness Assembly, PL 13.1.7.

Fuser Failure (cont'd)

Code 44: Indicates a failure in the Fuser Lamp circuit.

Troubleshooting Reference Table

Applicable Parts	Wiring and Plug/Jack Map References
Low-Voltage Power Supply, PL 12.1.10	"Fuser Assembly" on page 10-21
Fuser Harness Assembly, PL 5.1.9	

Warning

To avoid the potential of electric shock, ensure the power to the printer is off and the power cord is disconnected from the wall outlet prior to performing Step 2 of the following troubleshooting procedure..

Troubleshooting Procedure Table

Steps	Actions and Questions	Yes	No
1	Check the Fuser Assembly for evidence of fault or damage.	Replace the parts concerned.	Go to Step 2.
2	Remove the Fuser Assembly and check for broken or bent pins.	Replace the parts concerned.	Go to Step 3.
3	Does the error recur after the Fuser Assembly has been replaced with a new one?	Go to Step 4.	Complete
4	Replace the Low-Voltage Power Supply page 8-99. Does the error recur after the LVPS has been replaced?	Go to Step 5.	Complete
5	Troubleshoot using the wiring diagram "Fuser Assembly" on page 10-21. Does the printer function correctly after replacing any defective parts?	Complete	Go to Step 6.
6	Verify the voltage of P/J61-4 on the Motor Driver Board is 2.8 VDC.	Replace the LVNC3 Harness Assembly, PL 13.1.1.	Go to Step 7.
7	Verify the voltage of P/J42-11 on the Motor Driver Board is 2.8 VDC.	Replace the Motor Driver Board, page 8-101.	Go to Step 8.
8	Verify the voltage of P/J12-20 on the Engine Control Board is 2.8 VDC.	Replace the Engine Control Board, page 8-107.	Replace Front 1A Harness Assembly, PL 13.1.7.

Fuser Failure (cont'd)

Fuser CRUM Failure

Code 45: CRUM data revise failure

Code 46: CRUM setting value failure

Code 47: This is the generic fuser code displayed when the printer cannot generate a specific error. This error code can represent any fuser error code from 40 through 46. In this instance, all of the Fuser Failure troubleshooting procedures need to be completed until the error is resolved..

Troubleshooting Reference Table

Applicable Parts	Wiring and Plug/Jack Map References
EEPROM Board, PL 10.1.16	"Fuser Assembly" on page 10-21
FSR 2 Harness Assembly, PL 5.1.9	"Laser Unit" on page 10-22

Warning

To avoid the potential of electric shock, ensure the power to the printer is off and the power cord is disconnected from the wall outlet prior to performing Step 2 of the following troubleshooting procedure..

Troubleshooting Procedure Table

Step	Actions and Questions	Yes	No
1	Check the Fuser Assembly for evidence of fault or damage.	Replace the parts concerned.	Go to Step 2.
2	Remove the Fuser Assembly and check for broken or bent pins.	Replace the parts concerned.	Go to Step 3.
3	Does the error recur after the Fuser Assembly has been replaced with a new one?	Go to Step 4.	Complete
4	Troubleshoot using the wiring diagram "Fuser Assembly" on page 10-21. Does the printer function correctly after replacing any defective parts?	Go to Step 5.	Replace the Assembly, Harness Fuser PL 13.1.
5	Troubleshoot using the wiring diagrams "Laser Unit" on page 10-22 and "Fuser Assembly" on page 10-21 for the EEPROM Harness.	Replace the Engine Control Board, page 8-107.	Replace EEPROM Harness Assembly, PL 13.1.10.

Fuser Fan Failure

Code 50

Troubleshooting Reference Table

Applicable Parts	Wiring and Plug/Jack Map References
Fuser Fan, PL 1.1.7	“Drive Section” on page 10-18
Motor Driver Board, PL 12.1.12	

Troubleshooting Procedure Table

Steps	Actions and Questions	Yes	No
1	Check the Fuser Fan for evidence of fault or damage.	Replace the Fuser Fan, page 8-8.	Go to Step 2.
2	Does an error recur after the Fuser Fan has been replaced?	Replace the Engine Control Board, page 8-107.	Go to Step 3.
3	Does the error recur after the Motor Driver Board has been replaced?	Go to Step 4.	Complete
4	Troubleshoot using the wiring diagram “Drive Section” on page 10-18. Replace any defective parts. Does the printer function correctly after replacing any defective parts?	Complete	Go to Step 5.
5	Print one sheet. Verify the voltage between P/J12-4<=>P/J12-17 on the Engine Control Board is +3.3 VDC.	Replace the DRV2-2 Harness Assembly, PL 13.1.3.	Replace the Engine Control Board, page 8-107.

Rear Fan Failure

Code 51

Troubleshooting Reference Table

Applicable Parts	Wiring and Plug/Jack Map References
Rear Fan, PL 12.1.2	"Main Wiring Diagram" on page 10-15
Low-Voltage Power Supply, PL 12.1.10	

Troubleshooting Procedure Table

Steps	Actions and Questions	Yes	No
1	Check the Rear Fan for evidence of fault or damage.	Replace the Rear Fan, page 8-102.	Go to Step 2.
2	Does an error occur after the Rear Fan is replaced?	Go to Step 3.	Complete
3	Replace the Low-Voltage Power Supply Board, page 8-99. Does the error recur after the LVPS is replaced?	Go to Step 4.	Complete
4	Troubleshoot using the wiring diagram "Main Wiring Diagram" on page 10-15. Replace any defective parts. Does the printer function correctly after replacing any defective parts?	Complete	Replace the Engine Control Board, page 8-107.

Generic Fan Failure

Code 52: This is a generic fan error, generated by the Rear Fan or the Fuser Fan circuit.

Troubleshooting Reference Table

Applicable Parts	Wiring and Plug/Jack Map References
Fuser Fan, PL 1.1.7	“Main Wiring Diagram” on page 10-15
Rear Fan, PL 12.1.2	“Drive Section” on page 10-18

Troubleshooting Procedure Table

Steps	Actions and Questions	Yes	No
1	Check the following for evidence of fault or damage: Rear Fan, PL 12.1.2 Fuser Fan, PL 1.1.7	Replace the defective fan.	Go to Step 3.
2	Does problem recur following part replacement?	Go to Step 3	Complete
3	Isolate the problem fan by running service diagnostics testing both the Rear Fan and Fuser Fan. Did one of the fans fail?	Go to the troubleshooting procedure for the specific fan.	If both fans pass diagnostics replace the Engine Control Board, page 8-107.

Engine Firmware Failure

Code 70: Task Table overflow

Code 71: Timer Table overflow

Code 73: Queue Buffer overflow

Code 74: Communications buffer overflow

Code 78: ESS Video data fail

Code 79: This is a generic Engine Firmware Failure code generated when any other Engine Firmware Failure code fails to report to the controller properly.

Troubleshooting Procedure Table

Steps	Actions and Questions	Yes	No
1	Is the problem application related?	Forward the application information to ESS for evaluation.	Go to Step 2.
2	Turn printer power off and then back on. Does the error recur?	Replace the Engine Control Board, page 8-107.	Complete

Code 72: NVRAM verify error

Code 77: NVRAM data error

Troubleshooting Procedure Table

Steps	Actions and Questions	Yes	No
1	Remove and reinstall the Fuser and Imaging unit. Does the error recur?	Go to Step 3.	Complete
2	Are P/J 144 and P/J 145 on the EEPROM Board properly seated and defect free?	Go to Step 3.	Replace the EEPROM Board, page 8-86.
3	Turn printer power off and then back on. Does the error recur?	Replace the Engine Control Board, page 8-107.	Complete

Imaging Unit Firmware Failure

Code 75: This is an Imaging Unit CRUM data error.

Caution

Protect the imaging unit from exposure to light by covering the unit or placing in a light proof bag.

Troubleshooting Reference Table

Applicable Parts	Wiring and Plug/Jack Map References
Plate Dispenser Assembly PL 10.1.13	"Fuser Assembly" on page 10-21

Troubleshooting Procedure Table

Steps	Actions and Questions	Yes	No
1	Check the Imaging Unit for defects or possible damage.	Replace the parts concerned.	Go to Step 2.
2	Does the error recur if the Imaging Unit is replaced?	Go to Step 3.	Complete
3	Is the CRUM Harness connector damaged or improperly connected.	Replace the Plate Dispenser Assembly, PL 10.1.13.	Go to Step 5.
4	Does the error recur after the Plate Dispenser is replaced?	Go to Step 5.	Complete
5	Remove the left cover. Check the Gear Slide and the Rack V for damage or misalignment. Is the Rack V out of alignment? See page 8-77 for more information.	Damage can occur if the Gear and Rack are not in the proper position. With Door C open, push the Rack V up as far as it can go and then reinstall the gear slide.	Go to Step 7.
6	Does the error recur after the aligning the Gear and Rack?	Go to Step 7.	Complete
7	Check J710 <=> J71 on the CRUM Harness for continuity. Use the wiring diagram "Fuser Assembly" on page 10-21.	Go to Step 9.	Replace the CRUM Harness Assembly, PL 10.1.12.
8	Does the error recur after the replacing the CRUM harness?	Go to Step 9.	Complete

Troubleshooting Procedure Table

Steps	Actions and Questions	Yes	No
9	Check J71 <=> J140 on the EEPROM Harness Assembly for continuity. Use the wiring diagram "Fuser Assembly" on page 10-21.	Replace the Engine Control Board, page 8-107.	Replace the EEPROM Harness Assembly, PL 13.1.10.

Fuser Firmware Failure

Code 76: The CRUM firmware has failed.

Troubleshooting Reference Table

Applicable Parts	Wiring and Plug/Jack Map References
EEPROM Board, PL 10.1.14	"Fuser Assembly" on page 10-21
FSR 4 Harness Assembly, PL 5.1.9	"Laser Unit" on page 10-22

Warning

To avoid the potential of electric shock, ensure the power to the printer is off and the power cord is disconnected from the wall outlet prior to performing Step 2 of the following troubleshooting procedure..

Troubleshooting Procedure Table

Step	Actions and Questions	Yes	No
1	Check the Fuser Assembly for evidence of fault or damage.	Replace the parts concerned.	Go to Step 2.
2	Remove the Fuser Assembly and check for broken or bent pins.	Replace the parts concerned.	Go to Step 3.
3	Does the error recur after the Fuser Assembly has been replaced with a new one?	Go to Step 4.	Complete
4	Are P/J 144 and P/J 145 on the EEPROM board properly seated and defect free?	Go to Step 5.	Replace the EEPROM board page 8-86.
5	Check continuity of Harness Assembly (FSR4) between J145 <=> J232. Refer to the wiring diagram "Fuser Assembly" on page 10-21.	Go to Step 6.	Replace the Assembly, Harness (FSR4) PL 5.1.9.

Troubleshooting Procedure Table

Step	Actions and Questions	Yes	No
6	Check continuity of Harness Assembly EEPROM between J144 <=> J140.	Replace the Engine Control Board, page 8-107.	Replace EEPROM Harness Assembly, PL 13.1.10.

Controller to Engine Communications Failure

Code 81: This is a communication failure between the Image Processor Board and the engine control board.

Note

When replacing the Image Processor Board, the NVRAM, memory, configuration chip ('i' button), and hard drive must be transferred to the new Image Processor Board. When replacing the Engine Control Board the Store/Restore functions can be used to transfer data from the NVRAM to the new board instead of transferring the NVRAM.

Troubleshooting Procedure Table

Step	Actions and Questions	Yes	No
1	Cycle power to the printer. Is the error cleared?	Complete	Go to Step 2.
2	Is the error cleared by reseating the Image Processor Board to Engine Control Board.	Complete	Replace the Image Processor Board, page 8-110.
3	Is the error cleared after replacing the Image Processor Board? See note above.	Complete	Replace the Engine Control Board, page 8-107.

Engine NVRAM Error

Code 83: Engine NVRAM is corrupted or receiving wrong data from a CRUM.

Troubleshooting Procedure Table

Steps	Actions and Questions	Yes	No
1	Cycle power to the printer. Does the error still appear?	Go to Step 2.	Complete
2	Remove and reinstall the Imaging Unit and Fuser Assembly. Does the error recur after the power has been turned off and then on?	Go to Step 3.	Complete
3	Does the error recur if the Imaging Unit is replaced and the power has been turned off and then on?	Go to Step 4	Complete
4	Does the error recur if the Fuser Assembly is replaced and the power has been turned off and then on?	Go to Step 5	Complete
5	Does the error recur if the EEPROM board is replaced and the power has been turned off and then on?	Replace the Engine Control Board, page 8-107	Complete

Replace [Y] [M] [C] [K] Toner Cartridge

The CRUM reader detected a CRUM ID error or Non-Xerox toner cartridge installed in the printer.

Code 90: Cyan CRUM I.D. Error

Code 91: Magenta CRUM I.D. Error

Code 92: Yellow CRUM I.D. Error

Code 93: Black CRUM I.D. Error

Code 96: Non-Xerox Cyan toner detected

Code 97: Non-Xerox Magenta toner detected

Code 98: Non-Xerox Yellow toner detected

Code 99: Non-Xerox Black toner detected

Note

An empty cartridge, Non-Xerox Toner Use, or a fatal error within the cartridge or printer can cause this error condition. Check for an error code in the help text prior to troubleshooting. If a code is *not* present in the help text, go to the troubleshooting procedure for "Replace [Y] [M] [C] [K] Toner Cartridge or [Y] [M] [C] [K] Toner Is Low" on page 3-50. The "Non-Xerox Toner Detected" errors (Codes 96 ~ 99) are triggered when the customer gets the "[Y] [M] [C] [K] Toner Cartridge is Not a Genuine Xerox Product" **warning** message and *chooses* not to use it by selecting "Do Not Use" on the front panel.

Troubleshooting Reference Table

Applicable Parts	Wiring and Plug/Jack Map References
Genuine Xerox toner cartridge (consumable) PL 10.1.7~10	"Developer Section 1" on page 10-19

Troubleshooting Procedure Table

Step	Actions and Questions	Yes	No
1	Remove top cover and ensure that cartridge is locked in position. Does the error clear after locking the cartridge?	Complete	Go to Step 2.
2	Does the error recur after the pertinent toner cartridge has been replaced with <i>genuine</i> Xerox toner.	Go to Step 3.	Complete
3	Check the connection of the CRUM Reader Board to the CRUM Harness connector J341. Is the harness properly connected?	Go to Step 4.	Reconnect the harness to the CRUM reader board

Troubleshooting Procedure Table

Step	Actions and Questions	Yes	No
4	Does the error recur after the CRUM Reader board PL 10.1.21 has been replaced?	Go to Step 5.	Complete
5	Check continuity of the harness RFID2 (J341 - J3411) Does the harness show continuity?	Go to Step 6.	Replace the CRUM harness RFID2 PL 10.1.19.
6	Check continuity of the harness RFID (J34 - J3411) Does the harness show continuity?	Replace the Engine Control Board, page 8-107.	Replace the harness assembly RFID PL 13.1.13.

[Y] [M] [C] [K] Toner Cartridge Failure

Code 86, 87, 88, 89: A CRUM error occurred in the yellow, magenta, cyan, or black toner cartridge.

Troubleshooting Reference Table

Applicable Parts	Wiring and Plug/Jack Map References
Genuine Xerox toner cartridge (consumable) PL 10.1.7~10	"Developer Section 1" on page 10-19

Troubleshooting Procedure Table

Step	Actions and Questions	Yes	No
1	Remove top cover and ensure that cartridge is locked in position. Does the error clear after locking the cartridge?	Complete	Go to Step 2.
2	Does the error recur after the pertinent toner cartridge has been replaced?	Go to Step 3.	Complete
3	Check connection of the CRUM reader board to CRUM harness connector J341. Is the harness properly connected?	Go to Step 4.	Reconnect CRUM reader board to the harness .
4	Replace the CRUM reader board PL 10.1..21. Does the error recur after the CRUM reader board has been replaced?	Go to Step 5.	Complete
5	Check J341 <=> J3411 of CRUM harness RFID2 for continuity	Go to Step 6.	Replace CRUM harness RFID2 PL 10.1.19.

Troubleshooting Procedure Table

Step	Actions and Questions	Yes	No
6	Check J34 <=> J3411 of CRUM harness RFID for continuity.	Replace the Engine Control Board, page 8-107.	Replace CRUM harness RFID PL 13.1.13.

Non-Phaser 6250 Fuser

Code 94: CRUM I.D. error. A non-Phaser 6250 Fuser has been detected in the printer.

Troubleshooting Reference Table

Applicable Parts	Wiring and Plug/Jack Map References
Fuser Assembly PL 8.1.1	"Fuser" on page 10-21
	"Laser Unit" on page 10-22

Warning

To avoid the potential of electric shock, ensure the power to the printer is off and the power cord is disconnected from the wall outlet prior to performing Step 4 of the following troubleshooting procedure..

Troubleshooting Procedure Table

Steps	Actions and Questions	Yes	No
1	Check the part number on the Fuser. Is it a genuine Xerox Phaser 6250 part.	Go to Step 2.	Replace the Fuser, page 8-5.
2	Check the Fuser assembly for evidence of fault or damage.	Replace the parts concerned.	Go to Step 3.
3	Remove and reinstall the Fuser assembly. Does the error recur?	Go to Step 4	Complete
4	Remove the Fuser assembly and check for broken or bent pins.	Replace the parts concerned.	Go to Step 5.
5	Does the error recur after the Fuser assembly is replaced with a new one?	Go to Step 6.	Complete
6	Are P/J 144 and P/J 145 on the EEPROM board properly seated and defect free?	Go to Step 7.	Replace the EEPROM board, page 8-86.
7	Check continuity between J145 <=> J232 of Harness assembly FSR4. Refer to wiring diagram "Fuser Assembly" on page 10-21.	Go to Step 8.	Replace Assembly, Harness FSR4, PL 5.1.9.

Troubleshooting Procedure Table

Steps	Actions and Questions	Yes	No
8	Check continuity between J144 <=> J140 of Harness assembly EEPROM. Refer to wiring diagram "Laser Unit" on page 10-22.	Replace the Engine Control Board, page 8-107.	Replace Assembly, Harness EEPROM PL 13.1.10.

Non-Phaser 6250 Imaging Unit

Code 95: CRUM I.D. error. A non-Phaser 6250 Imaging Unit has been detected in the printer.

Troubleshooting Reference Table

Applicable Parts	Wiring and Plug/Jack Map References
Imaging Unit PL 9.1.3	"Xerographics 2" on page 10-24
	"Laser Unit" on page 10-22

Troubleshooting Procedure Table

Steps	Actions and Questions	Yes	No
1	Check the part number listed on the Imaging Unit. Is it a genuine Xerox Phaser 6250 part?	Go to Step 2.	Replace the Imaging Unit.
2	Remove and reinstall the Imaging Unit. Does the error recur?	Go to Step 3.	Complete
3	Remove the Imaging Unit and check for broken or bent pins on the connector.	Replace the Imaging Unit, page 8-4.	Go to Step 4.
4	Does the error recur after the Imaging Unit is replaced with a new one?	Go to Step 5.	Complete
5	Is the Imaging Unit connector P/J710 on the Plate Assembly Dispenser, PL 10.1.13, damaged?	Replace the Plate Assembly Dispenser, page 8-77.	Go to Step 6.
6	Check the connection of the CRUM Harness, PL 10.1.12, to the connector block. Is the harness properly connected?	Go to Step 7.	Reconnect the harness.

Troubleshooting Procedure Table

Steps	Actions and Questions	Yes	No
7	Replace the EEPROM board, PL 10.1.14. Does the error recur after the EEPROM board, has been replaced?	Go to Step 8.	Complete
8	Check J710 <=> J71 of the CRUM Harness for continuity.	Go to Step 9.	Replace the CRUM Harness, PL 10.1.12.
9	Check J71 <=> J140 of the EEPROM Harness for continuity.	Replace the Engine Control Board, page 8-107.	Replace the EEPROM Harness, PL 13.1.10.

Environmental Sensor Failure

Code 102: Indicates an error was detected in the environment sensor circuit.

Troubleshooting Reference Table

Applicable Parts	Wiring and Plug/Jack Map References
Temperature/Humidity Sensor, PL 3.2.2	“Xerographics 1” on page 10-23
Temp/Humidity Harness, PL 3.2.1	“Xerographics 2” on page 10-24

Troubleshooting Procedure Table

Steps	Actions and Questions	Yes	No
1	Use service diagnostics to test the Temperature/Humidity Sensor. Does the sensor function correctly?	Go to Step 2.	Replace the Temp/ Hum Sensor, page 8-24.
2	Does the error recur after replacing the Temperature/Humidity Sensor?	Go to Step 3.	Complete
3	Troubleshoot using the wiring diagrams “Xerographics 1” on page 10-23 and “Xerographics 2” on page 10-24 Is the problem resolved?	Complete	Replace the Engine Control Board, page 8-107.

General Troubleshooting

In this chapter...

- Introduction
- System Start-Up and POST
- Front Panel Troubleshooting
- Fault Isolation
- Inoperable Printer Troubleshooting
- Printer Inoperable after Power Switch is On
- AC Power Supply Troubleshooting
- DC Power Supply Troubleshooting
- Media Jams and the Paper Path
- Operating System and Application Problems
- Network Problems

Chapter 4

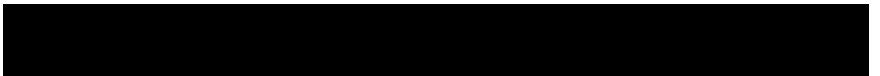

Introduction

This chapter covers the general start-up, Power On Self Test (POST), and power supply operations of the printer to aid in troubleshooting problems not associated with a front panel error message or error code. For troubleshooting problems associated with an error code or front panel error message, notes on how to use the troubleshooting procedure tables, and how to use service diagnostics, see Chapter 3 "Error Messages and Codes" on page 3-1. The Printer Status page also contains useful troubleshooting information. This page provides general printer information, life information for all consumables, color registration/calibration information.

Troubleshooting procedures will isolate a problem to a specific component or subassembly, in some cases including the wiring harness. If you go through the procedures in a troubleshooting table and still are unable to solve the problem, re-read the Theory of Operations for the problem area and ensure that you understand how that section of the printer is supposed to function.

Printer Status Page

The Printer Status Page is a two page printout that provides a great deal of useful troubleshooting information. Go to [Troubleshooting/Service Tools/Printer Status Page](#) and press **OK** to print these pages.

The first page includes general information about the printer including firmware versions, page count, feature set, and consumables installation dates and remaining life. This page also provides color registration, calibration, and print target examples.

The second page provides a rolling log of the last 50 printer faults with date, page count, description, and fault code. For troubleshooting information related to fault/error codes, refer to "Error Messages and Codes Summary Table" on page 3-17. For additional information, refer to the "Printer Status Codes" on page A-2.

Power-Up Modes

Connector J160, on the back edge of the Image Processor board allows selection of various power-up modes of operation that can be used for troubleshooting purposes. To access these modes, turn off the power and connect a jumper between the pin or pins indicated with an X in the following table and either of ground pins (G) 1 or 6.

Power-Up Mode Selection

Mode Selection	1	2	3	4	5	6
----------------	---	---	---	---	---	---

Power-Up Mode Selection

Mode Selection	1	2	3	4	5	6
Printer Reset	G				X	G
Customer	G					G
Service/Diagnostic	G		X	X		G
Disaster Recovery	G	X		X		G

System Start-Up and POST

System Boot Sequence

1. When the main power switch is turned on, the health LED on the Image Processor Board turns on.
2. The front panel Graphics Display is reset (addressable area turns grey).
3. The front panel LED cycles: Green, Yellow, Red, (approximately 1/3 second each) and then off.
4. The backlight is turned on (high intensity) with a nominal contrast display.
5. The Graphics Display is turned on with all ones (black) for 1 second and then cleared.
6. The backlight is turned on with nominal intensity.
7. The Power On Self Test Vn.nn message appears and tests are quickly executed. If any test fails, the front panel screen freezes with the name of the test displayed and another line is posted: "Call Customer Service".
8. The Xerox "splash screen" displays on the front panel and PostScript begins initialization.

Power On Self Test (POST)

The following tests are performed when the printer is powered on, after the boot loader runs, and before the operating system is loaded and initialized.

POST diagnostics are intended to provide a quick means of isolating a defective subsystem associated with the Image Processor Board, SDRAM, and ROM. POST returns control to the boot loader and the operating system is loaded. The operating system then loads the imaging processing software. If POST detected any soft errors, a message is printed in a red box on the start page. If the start page has been turned off, POST forces a start page to be printed. If POST detects any hard errors, both the front panel and health LED blink the error code pattern, see "LED Blink Patterns" on page 4-6.

POST Startup indications

- At power-on, the hardware default is to turn on the Image Processor (IP) Board 'health' LED.
- The IP Board 'health' LED is turned off.
- The front panel display is reset (addressable area becomes "gray").
- The Green LED turns on for 1/3 second.
- The Yellow LED turns on for 1/3 second.
- The Red LED turns on for 1/3 second.
- The front panel LED is turned off.
- The backlight is turned on (high intensity), with nominal contrast display.
- The front panel display area is turned on, dark black for 1 second.
- The front panel display is cleared.
- The backlight is turned on with nominal intensity.
- The POST Vn.nn message appears, and tests are quickly executed in the order shown in the Post Test Sequence table.
- If any tests fail, the front panel screen freezes with the name of the test displayed and the line posted is "Call Customer Service".
- After the POST tests have finished running, the Xerox 'splash screen' is posted to the front panel and PostScript begins initialization.

Post Test Sequence

Test Seq.	Code	Test Name	Type	Comments
1	1	SDRAM	Hard	Run by Bootloader
2	14	Real Time Clock	Soft	Initial time check for comparison
3	3	I/O ASIC	Hard	Checks I/O capability
4	4	Memory	Soft	
5	5	Configuration Chip	Hard	
6	7	Extended Memory	N/A	Autorun test only
7	10	EEPROM	Hard	
8	11	Ethernet	Hard	
9	12	CPU Interrupts	Hard	
10	13	USB	Hard	
11	14	Real Time Clock	Soft	Tests RTC operation
12	15	RAM DIMM	Soft	Bootloader test reported in POST
13	16	Min RAM Limit	Hard	Checks for sufficient RAM
14	17	Max RAM Limit	Soft	Checks for excess RAM
15	20	IDE Disk	Soft	
16	22	Engine Command	Hard	
17	26	Engine Fuser Warmup	Soft	Check Engine/Fuser communication
18	14	Real Time Clock	Soft	Compares RTC time to CPU time base register

POST Faults

There are two kinds of faults: soft and hard.

A soft fault is any fault that is discovered by POST, but does not prevent the operating system from initializing and becoming available as a tool for troubleshooting. These POST faults do not stop execution and are reported on the StartPage in a red box after the system is running.

A hard fault is any fault discovered by POST that prevents the operating system from initializing successfully. A hard fault prevents the system from further execution and is halted with blinking LEDs (front panel and health LED). The test name of the test that failed is displayed on the front panel.

Fault Reporting Devices

There are four fault presentation devices.

- All soft faults are printed on the StartPage.

For hard faults:

- The health LED flashes according to the fault code.
- The front panel LED flashes in unison with the health LED.
- The last posted message to the graphic front panel is present.

LED Blink Patterns

For faults identified as hard faults, the POST firmware causes the IP health LED to blink in a particular pattern to identify the fault. There are short and long blinks. A long blink is worth 5 and a short blink is worth 1. If a fault blink pattern is flashed as long, long, short, short, this is fault code $5+5+1+1=12$, which indicates a failure in the CPU interrupt test. See “POST Diagnostics Test Descriptions” on page 4-7.

The exception to the above pattern is a RAM test error. The RAM tests have a special blink pattern and the front panel displays “RAM Error”. During power up the front panel LED is on. If the RAM tests fail, the Image Processor Board health LED is turned off, and the front panel LED is red. At 1/2-second intervals, the health LED and the front panel LED toggle continuously.

POST Diagnostic Test Descriptions

Test	Fault Code	Description
SDRAM	1	(Hard) This test fails if the boot loader finds no RAM present or faulty RAM. (Run prior to POST.) Boot loader posts the message “RAM error” to the front panel and blinks the front panel LED.
I/O ASIC	3	(Hard) This test determines if the I/O chip is functioning properly and also makes a preliminary check of front panel functionality.
Memory	4	(Soft) Checks installed memory above diagnostics code and data addresses. Front panel displays “Memory” if a fault occurs.
“i” Button (Configuration Chip)	5	(Hard) This test checks to see if the “i” button (configuration chip) is present. If no chip is present the test will fail and the front panel message “Please Install “i” button” will display.
Extended Memory	7	This test does a write compare test to each 32-bit word in extended memory.
EEPROM	10	(Hard) This test checks addressing of the EEPROM.
Ethernet	11	(Hard) This test checks the ethernet core.
CPU Interrupts	12	(Hard) This test checks that each interrupt source to the CPU is functioning.
USB	13	(Hard) This test checks that the USB core is functioning properly.
Real Time Clock	14	(Soft) The real time clock is tested.
RAM DIMM Presence	15	(Soft) This test examines bad or incompatible RAM DIMMs.
Minimum RAM Limits	16	(Hard) Checks that there is at least 128 Mbytes installed. Front panel displays “Install More RAM” on failure.
Maximum RAM Limits	17	(Soft) Checks that there is no more than 512 Mbytes installed.
IDE Disk	20	(Soft) Checks for presence of hard drive, then checks the disk controller core, and runs a DIAGNOSE command on the hard drive.
Engine Command	22	(Hard) Runs multiple engine commands to verify proper operation. Displays “22:Reseat Controller Board” and “Call Customer Support” on failure.
Engine Fuser Warmup	26	(Soft) Checks for normal fuser operation. Failure will result in a red box on the StartPage with “Hardware Failure”.

Front Panel Troubleshooting

No Front Panel Display after Power is Turned ON

1. Remove and reseal the Image Processor Board, page 8-110.
2. Run the Print Engine Test Print, see page 5-9.
3. Replace the Image Processor Board page 8-110 (if Step 2 passes).
4. See “DC Power Supply Troubleshooting” on page 4-13.
5. Replace the Front Panel wiring harness page 8-6.
6. Replace the Front Panel page 8-7.

Front Panel LED is on, Front Panel Display is Blank

1. Remove and reseal the Image Processor Board page 8-110.
2. Replace the Front Panel wiring harness page 8-6.
3. Replace the Front Panel page 8-7.
4. Replace the Image Processor Board page 8-110.

Front Panel Continually Displays “Warming Up...”

1. Verify the correct Fuser (110 V vs 220 V) is installed in the printer.
2. See the Engine Power-Up Sequence on page 4-9.

Front Panel Continually Displays "Install or Reseat Imaging Unit"

1. See “Install or Reseat Imaging Unit” on page 3-42.
2. Realign Rack V, see "Toner Cartridge Holder Unit Assembly (PL 10.1)" on page 8-77

Fault Isolation

Isolate a fault to the Printer or to the Image Processor Board by running the Print Engine Test Print, see page 5-9.

- If the printer successfully prints the Print Engine Test Print, replace the Image Processor Board.
- If the Printer fails the Print Engine Test, troubleshoot the Print Engine starting with the "AC Power Supply Troubleshooting" on page 4-13.

Inoperable Printer Troubleshooting

Engine Power-Up Sequence

1. Engine Control Board logic check
2. Imaging Unit (Missing, NVRAM (CRUM) Error, CRUM ID, Life Over)
3. Fuser (Missing, NVRAM(CRUM) Error, Life Over)
4. Toner Cartridge (Missing, Life Over)
5. Transfer Roller (Missing, Life Over)
6. CTD Sensor (Error)
7. All paper sensor (Jam)
8. OHP sensor (Jam)
9. Door(s) (Open)
10. Environment Sensor (Error)
11. NVRAM (NVRAM error)
12. Image Processor Board POST Diagnostic check

Printer Does Not Come to a "Ready" State

- See "AC Power Supply Troubleshooting" on page 4-13.
- See "Fault Isolation" on page 4-9

Printer Inoperable after Power Switch is On

No mechanical initialization observed after the Power Switch is turned On. One possible cause of this condition is the protection circuitry on the LVPS has detected an overload condition and temporarily stopped all output. This protective shutdown lasts no more than 5 minutes following removal of the overload.

Initial Actions

- Turn off the printer's Power Switch and remove the Power Cord.
- Remove the Image Processor board (page 8-110).
- Wait 5 minutes before restoring power to allow the protection circuitry to reset.

Troubleshooting References

Applicable Parts	Wiring and Plug/Jack Map References
Low Voltage Power Supply, PL 12.1.10	"Power Supply" on page 10-16
Control Panel, PL 1.1.1	"Image Processor Board" on page 10-26
Image Processor Board, PL 12.1.4	"Image Processor Board" on page 10-26

Note

The Control Panel and indicator LEDs are disabled during print engine testing with the Engine Only Test Print.

Troubleshooting Procedure Table

Steps	Action and Questions	Yes	No
1	Test the print engine. <ol style="list-style-type: none">1. Power up the printer with the Image Processor Board removed.2. Run the Engine Only Test Print (page 5-9). Was the Test Print successful?	Go to Step 2.	Go to Step 3.
2	Check the Image Processor Board (or one of its removable components, Memory, NVRAM, etc.), or the Control Panel as one of these components are most likely responsible for the overload condition. Does the problem still persist.	Go to Step 3.	Complete.

Troubleshooting Procedure Table (Continued)

Steps	Action and Questions	Yes	No
3	Turn off the printers power for a full 5 minutes then re-run the engine only test print. Does the Test Print run successfully?	Complete.	Go to Step 4.
4	Check print engine operation. Troubleshoot a defective engine, then troubleshoot the LVPS, Motor Driver board, or a motor / clutch connected to the engine. Refer to the Wiring Diagrams, while unplugging the various motors, clutches, and solenoids until the fan stays running and the LVPS maintains its outputs. Is the LVPS outputs restored?	Replace the component isolated during testing.	See "Fault Isolation" on page 4-9.

Paper Size Switch Assembly

Paper size and tray installation is detected by a combination of ON/OFF statuses of the upper, middle, and lower switches of the Switch Paper Size Assembly. Inability of the printer to detect the paper size loaded, or to detect the presence of the paper tray can be the result of a bad switch.

Paper size	Switches		
	Upper	Middle	Lower
LEGAL14"	ON	ON	ON
LEGAL13"	ON	ON	OFF
EXECUTIVE	ON	OFF	ON
B5	ON	OFF	OFF
A4	OFF	ON	ON
A5 (for reference only, supported in Tray 1 only)	OFF	ON	OFF
LETTER	OFF	OFF	ON
No Tray	OFF	OFF	OFF

Power Supply

Low-voltage Power Supply Overcurrent Protection Circuit

This circuit stops all outputs if the 24 VDC, 5 VDC or 3.3 VDC power supply is shorted. The circuit is reset when the short is removed, the power is turned off and then on again.

Low-voltage Power Supply Overvoltage Protection Circuit

This circuit stops all outputs if the 24 VDC, 5 VDC or 3.3 VDC power supply exceeds the specified voltage. The operating point is 32 VDC or more for 24 VDC, 7 VDC or more for 5 VDC, or 6 VDC or more for 3.3 VDC.

Fan Output Circuit

For the Fan Rear ON (H) signal, the output voltage varies depending on the status of FAN LOW signal and FAN STOP signal from the Fan Control circuit on the LVPS (refer to "Power Supplies" on page 10-16).

+24 VDC Output Stopped By Interlock Switch

Opening Door A, B or C opens the front cover interlock switch. This shuts off the +24 VDC supplied by the Motor Driver Board to the motors, clutches and solenoids.

AC Power Supply Troubleshooting

Troubleshooting References

Applicable Parts	Wiring and Plug/Jack Map References
Low Voltage Power Supply, PL 12.1.10	"Power Supply" on page 10-16
AC Switch Harness Assembly, PL 12.1.11	"Drive Section" on page 10-18

Procedure

Step	Action and Questions	Yes	No
1	1. Check the voltage at the AC wall outlet. Is there approximately 110 VAC (or 220 VAC if the printer is a 220 V model) at the AC wall outlet?	Go to Step 2.	Notify the customer of improper AC output from the outlet.
2	1. Check the power cord for defects or a loose connection.	Replace or reseal the power cord.	Go to Step [3].
3	1. Disconnect the Power Cord and turn the AC switch ON. 2. Check the AC Switch Harness for continuity. See "Drive Section" on page 10-18.	Replace the Low-Voltage Power Supply, page 8-99.	Replace the AC Switch Harness Assembly, page 8-98.

DC Power Supply Troubleshooting

Troubleshooting Reference

Applicable Parts	Wiring and Plug/Jack Map References
Low Voltage Power Supply, PL 12.1.10	"Power Supply" on page 10-16

Procedure

Step	Action and Questions	Yes	No
1	Perform the AC power supply troubleshooting procedure first, if this does not fix the problem go to Step 2.		
2	Turn the AC power Switch OFF. Is the fuse (F001) on the low-voltage power supply board open?	Replace the Low-Voltage Power Supply Board, page 8-99.	Go to Step 3.

Procedure (Continued)

Step	Action and Questions	Yes	No
3	<p>Disconnect the connectors J163, J164 and J165 from the LVPS, turn the AC power switch on and verify the DC voltages between the following pins on the Low Voltage Power Supply board.</p> <p>P163-1 <=> P163-2 = +24 VDC? P164-1 <=> P164-2 = +3.3 VDC? P165-1 <=> P165-2 = +5 VDC? P165-3 <=> P165-4 = +3.3 VDC?</p> <p>Caution</p> <p>Be careful not to touch any other pins during these measurements or you may blow the fuse (F001) on the LVPS.</p>	Go to Step 4.	Replace the Low-Voltage Power Supply Board, page 8-99.
4	<p>Turn the AC power switch OFF. Connect J164 to the LVPS then turn the AC power switch ON.</p> <p>P/J164-1 <=>P/J164-2 = +3.3 VDC?</p>	Go to Step 7.	Go to Step 5.
5	<p>Check the following parts for fault or damage:</p> <ul style="list-style-type: none"> ■ LVRPG Harness Assembly for damage or if it is shorted to the frame. ■ Engine Control Board. 	Replace if damaged or defective.	Go to Step 7.
6	Does the problem recur?	Go to Step 7	Complete
7	<p>Turn the AC power switch OFF. Connect J165 to the LVPS then turn the AC power switch ON.</p> <p>Verify:</p> <p>P/J165-1 <=> P/J165-2 = +5 VDC? P/J165-3 <=> P/J165-4 = +3.3 VDC?</p>	Go to Step 10.	Go to Step 8.
8	<p>Check the following parts for fault or damage:</p> <ul style="list-style-type: none"> ■ LVNC Harness Assembly ■ Motor Driver Board 	Replace if damaged or defective.	Go to Step 10.
9	Does the error recur?	Go to Step 10.	Complete
10	<p>Turn the AC power Switch OFF. Connect J163 to the LVPS then turn the AC power switch ON.</p> <p>P/J163-1 <->P/J163-2 = +24 VDC?</p>	Complete	Go to Step 11.
11	<p>Check the following for fault or damage:</p> <ul style="list-style-type: none"> ■ 24V Harness Assembly ■ Motor Driver Board 	Replace if damaged or defective.	Complete

Media Jams and the Paper Path

Media-Based Problems

1. Check that the correct type of media is being used; for the correct media types and weights, see "Printer Specifications" on page 1-11. The customer should be using a quality laser printer paper. The printer may have trouble picking slick-finish paper.
2. Only Phaser 25-Series Premium Transparency Film can be used in this printer.
3. Inspect the paper for bent, torn, or folded corners.
4. Check the paper path for obstructions or debris.
5. Ensure that the correct media type is set in the front panel.
6. Ensure that the paper guides are set correctly.
7. Ensure that the media is a supported type for the tray. See "Media and Tray Specifications" on page 1-14, for the correct media types, sizes and weights for each tray.
8. Load a fresh ream of paper in the tray.

Multiple-Sheet Pick

1. Ensure that the paper is in good condition and appropriate for a laser printer; quality office laser printer paper works best.
2. Ensure that the printer is printing within its environmental specifications by using the Printer Status Page.
3. Remove the tray and remove, fan, and reload the media. Ensure that the guides are securely against the paper and the tray has not been over filled.
4. Try loading paper from a fresh ream, fan the paper, and then insert into the tray or flip existing paper over.
5. Check the tray's retard roller for damage.
6. Clean the pick rollers with a clean, dry, lint-free wipe.
7. Replace the paper pick rollers.
8. Replace the paper tray.

Mis-Pick

1. Check that the correct type of media for the tray is being used and the paper guides are set correctly.
2. Remove, fan, and reload the media. Ensure that the tray has not been over filled.
3. Try loading paper from a fresh ream, fan the paper, and then insert into the tray or flip existing paper over.
4. Clean the pick rollers with a clean, dry, lint-free wipe.
5. Troubleshoot the paper pick roller assembly.

Skewed Image

1. The image area is not parallel with the sides of the page but the printer neither jams nor displays an error code.
2. Remove the tray and ensure the paper guides are set correctly.
3. Check that the correct type of media for the tray is being used.
4. Ensure that the tray has not been over filled. (Skewed images are a common defect when Tray 1 (MPT) is overfilled.)
5. Verify the paper pick rollers are installed correctly.
6. Clean the pick rollers with a clean, dry, lint-free wipe.
7. Troubleshoot the paper pick roller assembly.

Damaged Prints

The printed page exits the printer either wrinkled, creased, or torn. The printer neither jams nor displays an error code.

1. Stop the page at various points in the paper path to determine where the media becomes damaged. See “Paper Path Route” on page 2-15 for more information.
2. Try using the next heaviest type of paper. For more information print the Paper Tips Page from the printer’s Printable Pages Menu.
3. Feed paper through the printer from each of the available trays. Is the paper damaged when fed out of one tray but not when fed out of the others? If so, inspect the tray for damage, ensure that the media guides are set correctly and verify that the proper media is being used.
4. If media shows damage from all trays, check for problem in registration roller area.
5. Inspect the paper tray and path for debris or broken components.

Fuser Jams

1. Ensure the paper is in good condition and is the correct type for the printer. See “Media and Tray Specifications” on page 1-14 for the correct media types, sizes and weights for each tray. Try loading new media from a fresh ream.
2. For OHPs, ensure that only Phaser 25-Series Premium Transparency Film is being used.
3. Check that the Fuser is properly seated, locked and the gearing operates normally.
4. Check that the printer is operating within its environmental specifications by using the Printer Status Page.
5. Ensure that the loaded media matches the front panel settings.
6. Are the margins on the page greater than 5 mm?
7. Check the Fuser area for debris.
8. Visually inspect the Fuser baffle for burrs.

9. Test the fuser motor using service diagnostics.
10. See “Jam at Fuser Jam F” on page 3-19 for troubleshooting Fuser Jams.

Exit jams

1. Ensure the paper is in good condition and is the correct type for the printer. See “Media and Tray Specifications” on page 1-14 for the correct media types, sizes and weights for each tray.
2. Ensure the printer is within its operating environmental specifications.
3. If media is showing excessive curl when exiting, try loading new media from a fresh ream or a different type of media.
4. Ensure that the loaded media matches the front panel settings.
5. Is the jam caused by a heavy, stiff paper being used for two-sided printing? In such cases, a lighter grade of paper should be used, see the printer’s Paper Tips Page.
6. Clean all exit locations in the Fuser and the Assembly, Chute Exit with a clean, dry, lint-free wipe, if debris is visible.
7. Does the Exit Roller turn? Test the Duplex Motor using service diagnostics. For information on service diagnostics, see "Service Diagnostics" on page 3-9.
8. See “Jam at Duplex Jam D” on page 3-21 for troubleshooting duplex jams if the Duplex Motor test fails.

Operating System and Application Problems

Print an internal test print from the printer's front panel to ensure the problem is not printer related. See "Print Engine Test Print" on page 5-9. Troubleshooting tips and additional information are also available on the Xerox web site at: www.xerox.com/office/support. Information on software and other problems is available on the InfoSMART web site at: www.xerox.com/office/infosmart.

Macintosh printing problems

Image never prints

Note

The following steps are for diagnosing a networked printer running Mac OSX 10.2.6 or later, and assume that CentreWare® access is enabled. If you are using Mac OSX 10, but an earlier version than 10.2.6, upgrade first.

1. Cycle power to the printer Off and On and try printing again.
2. Determine the printer IP from the front panel or startup page. Return the front panel to the initial menu, and check to make sure it indicates "Ready to Print". If it does not indicate "Ready to Print", correct that first.
3. Make sure you can connect to the printer via network from the host: Open a safari or internet explorer window to the printer IP address. Once you have established basic network connectivity, proceed to Step 4.
 - a. If you can not see the CentreWare IS page from the printer CWIS web server, the printer may be off, on a different network, or the host is not networked correctly. Try Steps b through f to correct the problem. If you make any changes to the network, try printing the job again.
 - b. Open System Preferences, select Network, and select the TCP/IP tab. Make sure you have a valid IP address. The IP address for the host must be on the same subnet as the printer (the test in Step e can determine if subnet is set correctly). Correct the settings and retry if needed.
 - c. If you are on a network with a proxy server, ensure the local connections are excluded from the proxy. Check System Preferences, Proxies tab – in the Bypass proxy settings for these Hosts and Domains, to ensure the local network devices are excluded from proxy redirection.

For example: If you open Safari to the printer IP, and get an error message similar to "Error – the request item could not be loaded by the proxy.", you are probably accessing the proxy server for a local address. This is incorrect.

- d. Open the Terminal tool, and select New Window. Once you have a prompt, try network connectivity using the Ping command.

For example: `ping 13.62.70.112` will check for echo replies from the printer with that IP address.

- e. In the Terminal tool, try using Traceroute to determine if you are on the same subnet as your printer.

For example: `tracert 13.62.70.112` should produce exactly one hop before completing the trace. Correct as needed, and retry your print job.

- f. If you still cannot connect to the printer via network, try another computer.
4. In MAC OSX, open Print Center. Check to make sure the printer status does not indicate “Stopped”. If it does, check your network and insure the host system is on the same subnet as the printer. Correct if needed. Delete all jobs in the queue for the printer by double-clicking the printer name, selecting each job, and clicking Delete. Restart the print queue by clicking Start Jobs. Try your print job again.
 5. In the Print Center, select your printer. In the Printers menu, select Show Info. From the pull down menu in Printer Info, make sure the model number shown for the printer is correct. If the model number is wrong, click the model pull down, and re-install. Check the Installable Options and make sure they match the printer’ configuration. If any changes are made, retry your print job.
 6. If there is still no output, try printing from a simple application. Open TextEdit, select New File, and create a small test document. Select Print from the File menu.
 7. If an error message displays or there is no output, try turning on the PostScript error status from CentreWare IS or the printer front panel. PostScript will now output an error page if an error occurred during the print job, assuming the printer received it.
 8. Try printing again using the TextEdit tool. Once you have opened a document or created a new document, select Print from the File menu . Click on the Printer pull down and select Edit Printer List. Click the add button, or pick Add Printer from the Printers menu (The add button is configurable, so it may not be there). Select IP Printing from the pulldown menu. Put the IP address your printer in the Printer’s Address text area. Click on the Printer Model pulldown, and select XEROX. A scrolling list should appear. Pick the correct Xerox Phaser 6250 model. You can check the exact model from the startup page upper right corner. The new added printer will be shown in bold on the printer list, indicating it is the default printer. When you are done adding the new printer, close the printer list dialog. Now select your printer from the Printer pulldown and click Print in the dialog box.
 9. If you can print from the TextEdit tool, but cannot print from your application, the problem is likely in your application. Check for upgrade availability or contact the application vendor for further diagnosis.

Windows printing problems

Image never prints

1. Try printing a test page from the printer driver's properties dialog box.
2. Try printing from another application.
3. Try printing to another network/PostScript printer.
4. Try printing from another computer.
5. If the error returns, turn ON the PostScript error handler through the front panel PostScript Error Info in the Support menu, or CentreWare IS and print the document again. Take note of the information on the error page that just printed.

Network Problems

The Phaser 6250 printer maintains six logs in memory detailing network functions. The logs contain TCP/IP, NetWare, and AppleTalk initialization and runtime events. The logs can also be accessed remotely via CentreWare IS.

The logs list events chronologically. The log is limited in length; when the log is full the printer stops recording data to the log. The logs are stored on the Hard Drive so only new data is stored each time the printer's power is cycled.

There is a Connection Setup Page, Configuration Page, and a network reset available for troubleshooting Network problems.

To print an Start Log, Runtime Log or Configuration Page:

1. Enter normal 'Customer Mode'.

From the main menu, highlight **Printer Setup** menu for the **Configuration Page** or **Troubleshooting** menu for the logs and press **OK**.

1. Highlight **Configuration Page** on the **Printer Setup** menu and press **OK**, the Configuration Page will print. Or scroll to highlight **Network Log Pages** on the **Troubleshooting** menu and press **OK**.
2. Highlight the appropriate menu item from the list and select **OK**.
3. The selected log page will print.

Print-Quality Troubleshooting

In this chapter...

- Print-Quality Problems Overview
- Front Panel Test Prints
- Service Test Prints
- Print Engine Test Print
- Print-Quality Troubleshooting

Chapter 5



Print-Quality Problems Overview

Print-quality defects can be attributed to printer components, consumables, media, internal software, external software applications, and environmental conditions. To successfully troubleshoot print-quality problems, as many variables as possible must be eliminated. The first Step is to generate prints using printable pages embedded in the printer on laser paper from the supported media list. The paper should be from an unopened ream that has been acclimated to room temperature and humidity.

See the supported media list in "Xerox Supplies and Accessories" on page 9-51 for media that has been tested and approved for use in the Phaser 6250 printer. If the print-quality defect is still present when printing on approved media from an unopened ream, then software applications and environmental conditions need to be researched.

Print the Printer Status Page or Service Usage Profile to determine the temperature and humidity under which the printer is operating. Compare this to the environmental specifications for the printer found in "Environmental Specifications" on page 1-13 of this manual. Temperature and humidity extremes can adversely effect the Xerographic and fusing characteristics of the printer.

The Phaser 6250 printer uses an Imaging Unit that contains all the imaging drums and developers for all four colors in one Routine Maintenance Item. Print-quality defects can be isolated to one particular component in the print engine, See the Repeating Defects chart under "Defects Associated with Specific Printer Components" on page 5-3 or print the Repeating Defects Page from the front panel. When a single component of the Imaging Unit is causing a print-quality defect, the entire Imaging Unit must be replaced.

When analyzing a print-quality defect, first determine if the defect occurs in all colors or only one color and if it is repeating or random. Defects occurring in only one color are usually attributable to the Imaging Unit. Continuous defects in the process direction, such as voids and lines, are the most difficult to diagnose. The visible surfaces of all rollers should be inspected for obvious defects. If no defects are observed, the Imaging Unit, Transfer Roller and Fuser should be changed one at a time until the defect has been eliminated.

Defects Associated with Specific Printer Components

Some print-quality problems can be associated with specific assemblies, the most common problems and the associated assemblies are listed below. Also, refer to the specific print-quality troubleshooting procedure for more information.

Imaging Unit

- Streaks
- Fine Lines
- Banding in Process Direction
- Uneven Density
- Voids
- Repeating Defects

Transfer Roller

- Toner on the back side of the printed page (simplex mode)
- Light Prints
- Repeating Defects

Fuser

- Hot or Cold Offsetting
- Repeating Defects

Repeating Defects

Routine Maintenance Item	Component	Distance between Defects
Imaging Unit	Developer Roller [YMCK]	28 mm (1.10 in.)
	Drum [YMCK]	62 mm (2.44 in.)
	Drum Charge Rollers	25 mm (1 in.)
	IDT 1 (Y and M, C and K)	132 mm (5.20 in.)
	IDT 2 all colors together	132 mm (5.20 in.)
Transfer Roller	Transfer Roller	64 mm (2.52 in.)
Fuser Assembly	Fuser Assembly	82 mm (3.23 in.)

Front Panel Test Prints

A variety of test prints are available to aid in determining the quality of output from the printer and to assist in troubleshooting problems. This section shows how to select and analyze all test prints available.

From the printer's front panel display, select **Troubleshooting** menu, select **Service Tools Menu** and then select **Service Test Pages**.

Test Print 1: CMYK Sample Page

This page consists of four 25% tint primary color bands.

Analyzing the Test Print

- Repeating defects
- Missing Color(s)
- Streaks
- Voids
- Banding

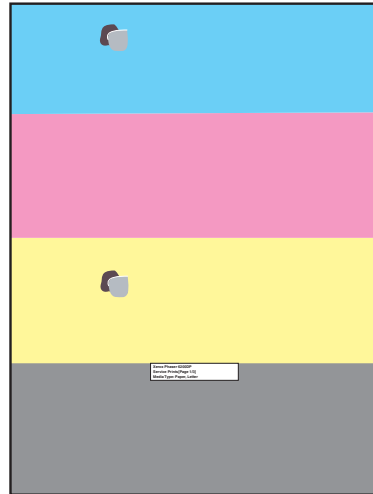

S6200-222

Test Print 2: RGB Test Print

This page consists of 80% solid fill in RGBK Bands.

Analyzing the Test Print

- Wrinkling
- Creases
- Roller marks
- Scratches
- Cold Offset

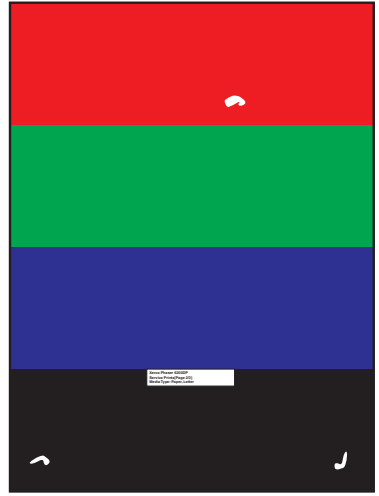

S6200-224

2. Color Registration (Vertical): The colored lines should match up as shown below. Vertical printing issues are corrected automatically when the Color Registration page is printed.



6250-502

3. Uniform RGB: The secondary color squares should be uniformly colored with no mottling.
4. Density: The color bars should have even density from top to bottom.
5. Margins: Should be 8 mm from the edge of the paper to the line.
6. Image Size: the image height should be 261 mm between the top and bottom lines. The image width should be 192 mm between the left and right lines.

600 x 600 Service Test Print

This test print is used to verify margins and color registration. The colors should be aligned vertically and horizontally.

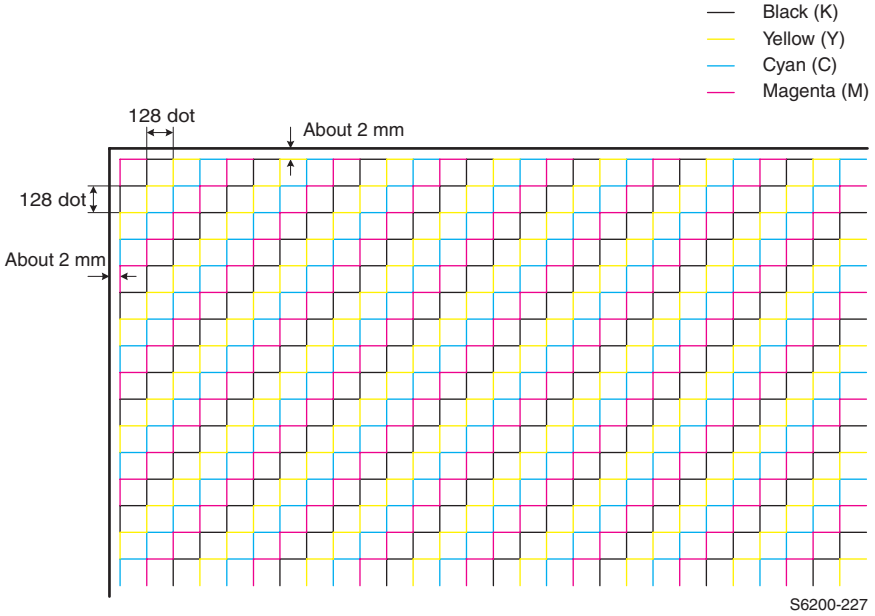

Print Engine Test Print

Print-quality and engine logic or hardware problems can be easily isolated to either the Image Processor Board or the Print Engine by running the Print Engine Only Test Print.

1. Turn printer power OFF.
2. Remove the Image Processor Board.
3. Turn printer power ON.
4. Look inside the Image Processor Board cavity, on the rear of the Engine Control Board locate jumper pins 1 and 2 on connector P31. See figure below or "Map 3" on page 10-8 for P31 location.
5. With a long screwdriver, touch the pins to short and start the test process, the pins must remain shorted to execute the test.
6. The printer will begin to print the 600 x 600 engine test print unless an error status from the Engine Control Board is present. Printing will continue until the jumper is removed from pin 1 to 2. The prints that are in process will be completed.

Note

Power to the front panel is disabled during this test. The front panel graphics and all LED's are off.

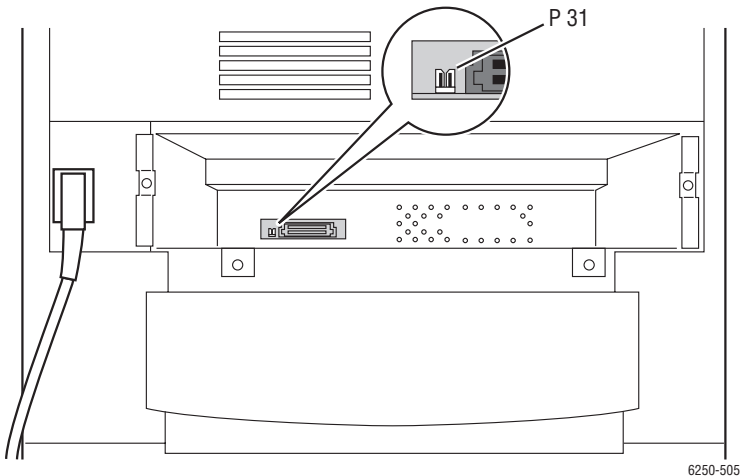

Print-Quality Troubleshooting

Light Prints

Initial Actions:

- Verify the printer is not in Draft mode.
- Verify the media used is supported by this printer. "Media and Tray Specifications" on page 1-14. lists correct media types, sizes, and weights for each tray.
- Verify the media settings are correct at the front panel.
- Run the color calibration routine prior to using this troubleshooting procedure.

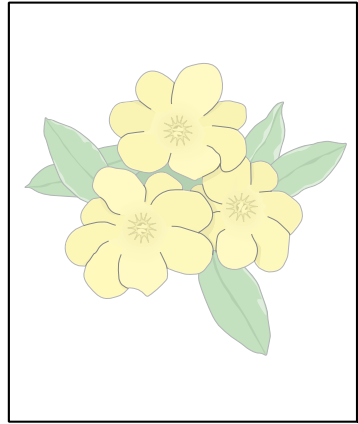

S6200-283

Troubleshooting Procedure

Step	Check	Yes	No
1	Check the Imaging Unit, Fuser Assembly and Transfer Roller for correct installation, damage or contamination, and life remaining.	Replace or reinstall the affected component.	Go to Step 2.
2	Does the image quality improve if the Imaging Unit is replaced?	Complete.	Go to Step 3.
3	Does the image quality improve if the Transfer Roller is replaced?	Complete	Go to Step 4.
4	Check the Front 1A Harness for continuity. P/J5030 <=> Transfer roller. P/J5020 <=> Transfer roller	Go to Step 5.	Replace the defective harness.
5	Does the image quality improve if the Laser Unit is replaced?	Complete	Go to Step 6.
6	Does the image quality improve if the SUB-HVPS is replaced?	Complete	Go to Step 7.
7	Check the FRONT 1A Harness for continuity.	Go to Step 8.	Replace the Front 1A , Harness Assembly PL 13.1.7.
8	Does the image quality improve if the Fuser is replaced, PL 8.1.1	Complete	Replace the Engine Control Board, page 8-107.

Light Print in Only One Color

Only one color; yellow, magenta, cyan, or black, is too light on the printed image. The test print is 25% coverage.

Initial Actions

- Verify that color calibration has been performed prior to using this troubleshooting procedure.

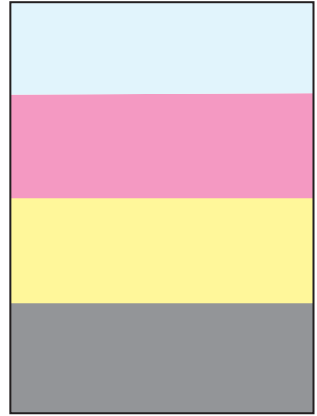

S6200-272

Troubleshooting Procedure

Step	Check	Yes	No
1	Is the affected color(s) toner supply empty? (Check the top of the auger tube for the affected color.)	Replace Toner Cartridge, PL 10.1	Go to stop 2.
2	Check the Imaging Unit for correct installation, damage or contamination. Verify the shipping seals are completely removed.	Replace the Imaging Unit . PL 9.1.3.	Go to Step 3.
3	Inspect the Developer Bias Plunger Stud of the affected color for proper spring pressure, compare to the other colors. Check for contamination.	Go to Step 4.	Replace the Housing Assembly Bias page 8-69.
4	Check for foreign objects or contamination present in the laser beam path between the Laser Unit and the Imaging Unit.	Remove object and/ or contamination.	Go to Step 5.

Troubleshooting Procedure

Step	Check	Yes	No
5	Check the following pins between the Engine Control Board and the Housing Assembly Bias for continuity, depending on the color affected. J 601<=>DEVE Y contact J 602<=>DEVE M contact J 603<=>DEVE C contact J 604<=>DEVE K contact	Go to Step 6.	Replace the Housing Assembly Bias page 8-69.
6	Replace the Laser Unit, page 8-68. Does the image quality improve if the Laser Unit is replaced?	Complete	Replace the Engine Control Board, page 8-107.

Blank Prints

The entire image area is blank

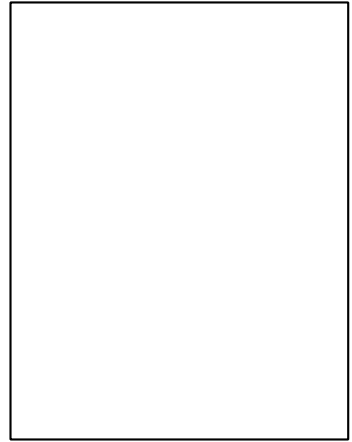

S6200-288

Troubleshooting Procedure

Step	Check	Yes	No
1	Ensure that the Laser Unit is properly seated in the chassis. Check for any obstructions in the laser beam path between the Laser Unit and the Imaging Unit.	Seat the Laser Unit correctly or remove the obstruction.	Go to Step 2.
2	Replace the Imaging Unit PL 9.1.3. Does the image quality improve if the Imaging Unit is replaced?	Complete	Go to Step 3.
3	Replace the Transfer Roller PL 8.1.12. Does the imaging quality improve if the Transfer Roller is replaced?	Complete	Go to Step 4.
4	Replace the Laser Unit, page 8-68. Does the image quality improve if the Laser Unit is replaced?	Complete	Go to Step [5].
5	Run the 600 x 600 test print see "Print Engine Test Print" on page 5-9. Does the output match the example on page 5-8?	Replace the Image Processor Board page 8-110.	Replace the Engine Control Board, page 8-107.

Black Prints with White Margin Border

The entire image area, except the margins, are black

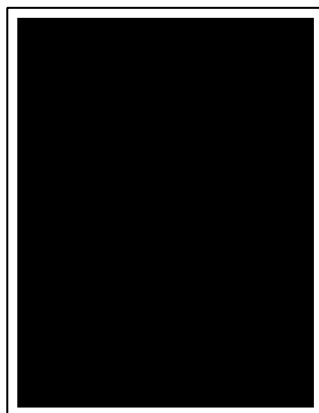

S6200-289

Troubleshooting Procedure

Step	Check	Yes	No
1	Run the 600 x 600 test print see "Print Engine Test Print" on page 5-9. Does the output match the example on page 5-8?	Replace the Image Processor Board, page 8-110.	Go to Step 2.
2	Block the laser path with a sheet of paper. Does the image change?	Replace the Engine Control Board, page 8-107.	Go to Step 3.
3	Replace the Imaging Unit, PL 9.1.3. Does the image quality improve if the Imaging Unit is replaced?	Complete	Go to Step 4.
4	Replace the Laser Unit, page 8-68. Does the image quality improve if the Laser Unit is replaced?	Complete	Replace the Engine Control Board, page 8-107.

Solid Dark or Dirty Prints, No Border

The prints appear very dirty and brown over the entire page.

This print-quality symptom is a composite image of all colors with no margin. This is caused by a charge voltage failure. For information on the Imaging Unit charge contacts, see "Theory of Operation" on page 2-1.



S6200-292

Troubleshooting Procedure

Step	Check	Yes	No
1	Is the problem resolved after replacing the Imaging Unit?	Complete	Go to Step [2].
2	Inspect the Imaging Unit charge voltage contacts (PL9.1.5) and the Bias Housing Assembly (PL 9.1.4) in the printer for any damage or defects. See "Imaging Unit Charge Voltage Contacts" on page 2-36.	Complete	Go to Step [3].
3	Is the problem resolved after replacing the Sub-High Voltage Supply Board, page 8-87?	Complete	Replace the Engine Control Board, page 8-107.

Note

After replacing any component in Step 2 or 3, run the Clean the Imaging Unit from the Maintenance section of Service Diagnostics. See "Service Diagnostic Tests" on page 3-9.

Missing Band, Voids Or Streaks In a Single Color or All Colors Parallel to the Leading Edge

There are areas of the image that are extremely light or missing entirely. These missing areas form bands parallel to the leading edge.

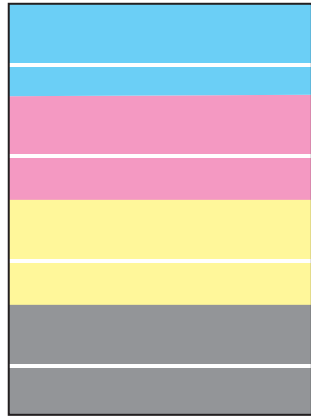

S6200-273

Troubleshooting Procedure

Step	Check	Yes	No
1	Is the 600 x 600 test pattern, printed as specified in "Print Engine Test Print" on page 5-9, correct?	Replace the Image Processor Board, page 8-110.	Go to Step 2.
2	Is the paper wrinkled, dimpled or show any signs of having a high moisture content? Is the problem resolved by loading fresh dry paper?	Complete	Go to Step 3.
3	Print a Repeating Defects Page. Do the defects correspond to a Routine Maintenance Item? See "Repeating Defects" on page 5-3	Replace the indicated Routine Maintenance Items.	Go to Step 4.
4	Replace the Imaging Unit PL 9.1. Does the image quality improve if the Imaging Unit is replaced?	Complete	Go to Step 5.
5	Replace the Transfer Roller, PL 8.112. Does the image quality improve if the Transfer Roller is replaced?	Complete	Go to Step 6.
6	Replace the Fuser Assembly, PL 8.1.1. Does the image quality improve if the Fuser is replaced?	Complete	Go to Step 7.
7	Check the following pins for continuity; J5030 and J5020 <=> Transfer Roller.	Go to Step 8.	Replace the defective wire.

Troubleshooting Procedure

Step	Check	Yes	No
8	Replace the Sub-HVPS, page 8-87. Does the image quality improve if the Sub-HVPS is replaced?	Complete	Go to Step 9.
9	Replace the Laser Unit, page 8-68. Does the image quality improve if the Laser Unit is replaced?	Complete	Replace the Engine Control Board, page 8-107.

Missing Band, Voids or Streaks in a Single Color or All Colors in Direction of Paper Travel

There are areas of the image that are extremely light or missing entirely. These missing areas form bands that run along the paper from the leading edge to the trailing edge, in the direction of paper travel.



S6200-274

Troubleshooting Procedure

Step	Check	Yes	No
1	Print the 600 x 600 test print and evaluate the print. Are there defects in the print?	Go to Step [2].	Replace the Image Processor Board, page 8-110.
2	Check for an obstruction in the laser beam path between the Laser Unit and the Imaging Unit. Lay Imaging Unit on it's back with the IDT Rollers facing up and rotate the developer gears to remove any loose toner.	Remove the obstruction or debris.	Go to Step 3.
3	Replace the Imaging Unit, PL 9.1.3. Does the image quality improve if the Imaging Unit is replaced?	Complete	Go to Step 4.
4	Replace the Transfer Roller PL 8.1.12. Does the imaging quality improve if the Transfer Roller is replaced?	Complete	Go to Step 5.
5	Replace the Fuser Assembly, PL 8.1.1. Does the image quality improve if the Fuser is replaced?	Complete	Go to Step 6.
6	Replace the Laser Unit, page 8-68. Does the image quality improve if the Laser Unit is replaced?	Complete	Replace the Engine Control Board, page 8-107.

Repeating and/or Random Spots

Spots of toner are randomly scattered across the page or at a fixed repeating interval.

Note

Depending on the type of paper and environmental conditions, some light amount of random background spotting (backgrounding) is normal. The whiter and glossier the paper, the more noticeable it will be.

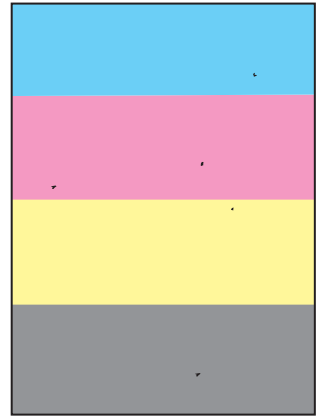

S6200-276

Troubleshooting Procedure

Step	Check	Yes	No
1	Print the Repeating Defects Page from the Troubleshooting <-> Print Quality Problems Menu. Do the defects correspond to a Routine Maintenance Item? See "Repeating Defects" on page 5-3.	Replace the indicated Routine Maintenance Item.	Go to Step 2.
2	Replace the Imaging Unit, PL 9.1.3. Does the image quality improve if the Imaging Unit is replaced?	Complete	Go to Step 3.
3	Replace the Transfer Roller, PL 8.1.12. Does the image quality improve if the Transfer Roller is replaced?	Complete	Go to Step 4.
4	Replace the Fuser Assembly, PL 8.1.1. Does the image quality improve if the Fuser is replaced?	Complete	Go to Step 5.
5	Replace the SUB-HVPS, page 8-87. Does the image quality improve if the SUB HVPS is replaced?	Complete	Go to Step 6.
6	Replace the Laser Unit, page 8-68. Does the image quality improve if the Laser Unit is replaced?	Complete	Replace the Engine Control Board, page 8-107.

Background Contamination

There is toner contamination on all or most of the page. The contamination appears as a very light gray dusting. The printer displays no error code. Before using this procedure, Ensure the TekColor correction is not set to “None” in the printer’s dialog box. Ensure the customer is making less than 2,000 prints per day. Making more than 2,000 prints a day exceeds the duty cycle specifications for the printer.

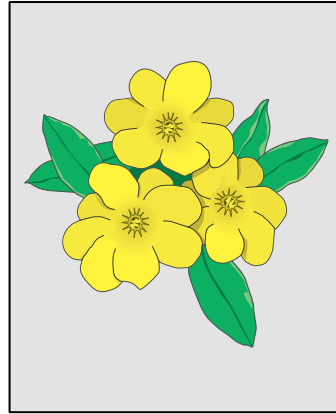

S6200-285

Note

Depending on the type of paper and environmental conditions, some light amount of random background spotting (backgrounding) is normal. The whiter and glossier the paper, the more noticeable it will be.

Troubleshooting Procedure

Step	Check	Yes	No
1	Check the Imaging Unit, Fuser Assembly and the Transfer Roller for correct installation, damage or contamination.	Replace or reinstall the affected component.	Go to Step 2.
2	Inspect the surface of the Transfer Roller for wast toner. The roller should appear black and shiny. Is the roller contaminated with waste toner?	Replace the Transfer Roller, page 8-4	Go to Step 4.
3	Does the image quality improve if the Transfer Roller is replaced?	Complete	Go to Step 4.
4	Replace the Imaging Unit, PL 9.1.3. Does the image quality improve if the Imaging Unit is replaced?	Complete	Go to Step 5.
5	Replace the Fuser Assembly, PL 8.1.1. Does image quality improve if the Fuser is replaced?	Complete	Go to Step 6.
6	Check the following pins to the transfer roller contacts for continuity: J5030 <=> Transfer Roller J5020 <=> Transfer Roller	Go to Step 7.	Replace the defective harness.

Troubleshooting Procedure

Step	Check	Yes	No
7	Replace the Laser Unit, page 8-68. Does the image quality improve if the Laser Unit is replaced?	Complete	Go to Step 8.
8	Replace the Sub-HVPS, page 8-87. Does the image quality improve if the Sub-HVPS is replaced?	Complete	Go to Step 9.
9	Check J 5011 <=> J13 for continuity.	Replace the Engine Control Board, page 8-107	Replace the Front 1A , Harness Assembly PL 13.1.7.

Residual Image, Ghosting or Hot Offset

There are faint, ghostly images appearing on the page. The images may be either from a previous page or from the page currently printed. The printer displays no error code.

Hot Offset: A light image of the print is repeated and offset 82 mm. See "Repeating Defects" on page 5-3.

Note

This type of artifact can be related to the percent coverage called out in the file being printed. Verify that Color Correction is not set to "None" mode.

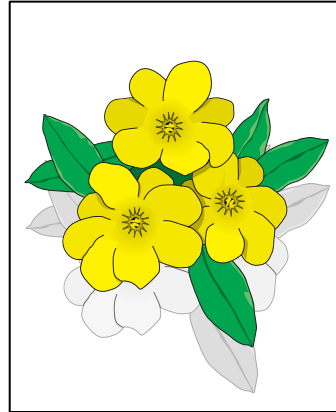

S6200-284

Troubleshooting Procedure

Step	Check	Yes	No
1	Was the customer printing numerous copies of the same image?	Avoid long runs of the same image.	Go to Step 2.
2	Set the paper to the next heaviest type. Does this resolve the problem?	Complete	Go to Step 3.
3	Does the ghosting appear in only one or 2 colors?	Replace the Imaging Unit, PL 9.1.3.	Go to Step 4.
4	Does the image quality improve after the Fuser has been replaced?	Complete	Go to Step 5.
5	Does the imaging quality improve if the Transfer Roller is replaced?	Complete	Go to Step 6.
6	Does the image quality improve if the LVPS is replaced? (The fuser control circuit is located on the LVPS)	Complete	Go to Step 7.
7	Print a Printer Status Page, do the temperature and humidity values reported seem to agree with the actual conditions?	Replace the Engine Control Board, page 8-107.	Replace the Temperature/Humidity Sensor, page 8-24.

Incomplete Fusing or Cold Offset

- **Incomplete Fusing:** The toner is not completely fused to the paper and easily rubs off.
- **Cold Offset:** Portions of the image are not fully fused and flake or rub off.



S6200-224

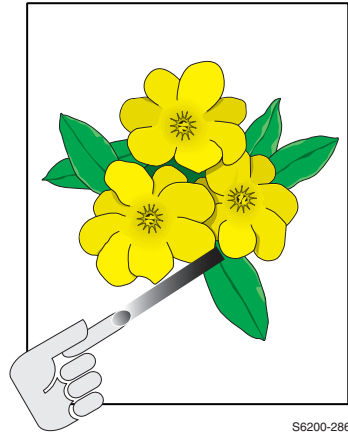

S6200-286

Troubleshooting Procedure

Step	Check	Yes	No
1	<p>Is the problem resolved by running “Remove Print Smears” from the Troubleshooting <=> Print Quality Problems Menu on the printer’s front panel.</p> <p>Is the problem resolved by changing the paper type setting on the printer?</p> <p>Hot offset: One type lighter.</p> <p>Cold offset / Incomplete fusing: One type heavier.</p>	Complete	Go to Step 2.
2	<p>Replace the Fuser Assembly.</p> <p>Does the problem recur after the Fuser is replaced?</p>	Replace the LVPS, page 8-99.	Complete.

Mis-Registration, Color Layer not Correctly Registered in the Process Direction

The four colors of the image are not registered correctly into one image.

Initial Actions:

- If the mis-registration is in the horizontal direction, perform the color registration adjustment. See "Horizontal and Vertical Color Registration" on page 6-3.
- If the mis-registration is in the vertical direction, clean the CTD (ADC) Sensor, then print the Color Registration Page. This forces the printer to perform a vertical registration adjustment. Check to see if the problem still appears before using this procedure.

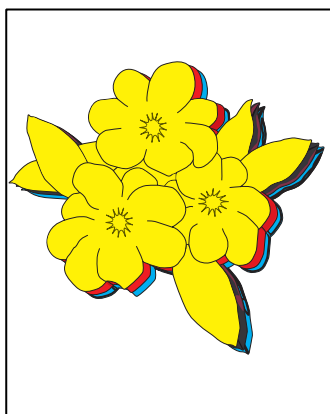

S6200-287

Troubleshooting Procedure

Step	Check	Yes	No
1.	Reseat the Imaging Unit. Ensure Door C is fully closed and latched. Ensure Transfer Roller is fully seated and clipped in place. Is the problem resolved?	Complete	Go to Step 2.
2.	Clean the CTD Sensor and cycle power to the printer. Is the problem resolved?	Complete	Go to Step 3.
3.	Replace the CTD Sensor. Is the problem resolved?	Complete	Go to Step 4.
4.	Print the 600 x 600 Service Test Print. Are all the colors aligned both vertically and horizontally?	Replace the Image Processor Board, page 8-110.	Go to Step 5.
5.	If only one color is affected, replace the Imaging Unit. Does this solve the problem?	Complete	Go to Step 6.
6.	If Laser Unit is not properly seated, reseal. If it is properly seated, replace the Laser Unit, page 8-68. Does this solve the problem?	Complete	Replace the Engine Control Board, page 8-107.

Dirty Vertical Streaks on the Edges of the Page

Simplex Print: Streaks are on the back side of the page.

Duplex Print: Streaks are on both sides of the page.

Note

The most likely cause of this artifact is high clay content paper. This component in the paper gums up the Transfer Roller cleaning blade. It can also be caused by a full Transfer Roller waste bin and other problems.

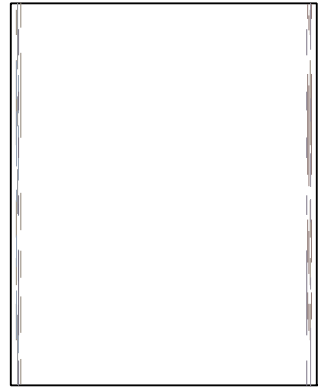

6250-500

Troubleshooting Procedure

Step	Check	Yes	No
1.	Is the problem resolved by using different media?	Complete	Replace the Transfer Roller, page 8-4.
2.	Check for reversed wiring to the toner motors. Is the wiring correct?	Replace the Imaging Unit.	Correct wiring error.

Adjustments and Calibrations

In this chapter...

- Calibrations
- Adjustments
- Resetting NVRAM
- Service Diagnostics PostScript NVRAM Resets

Chapter 6

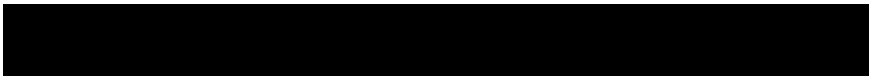

Calibrations

Color Calibration

Color calibration procedures adjust the printer for optimal color output. Color settings may need adjustment:

- On initial printer setup.
- When Toner Cartridges and Imaging Units are replaced.
- When the printer environment changes.
- If the printer has been stored for some time.
- If the printer has not received significant use.

There are two procedures; Lighten/Darken Colors and Balance Colors.

If the overall image appears either too light or dark, use the Lighten/Darken colors procedure. If a finer adjustment of the primary colors, cyan, magenta and yellow, is needed, continue with the balance colors procedure.

Print the **Calibrate Colors Tutorial Page** from the printer's front panel **Troubleshooting** <=> **Print Quality Problems Menu** and follow the instructions detailed on the page.

Margin Calibration

The Calibrate Margins Menu allows you to adjust the printer's imaging area relative to the edges of the paper. The imaging area is shown as a dashed rectangle on the front side of the print, the printer will not print outside this rectangle. The dashed rectangle should line up with the solid rectangle printed on the back side of the page. Hold up to strong light for verification.

Print the **Calibrate Margins Page** from the printer's front panel **Troubleshooting** <=> **Print Quality Problems Menu** and follow the instructions detailed on the page.

Adjustments

Horizontal and Vertical Color Registration

Horizontal Color Registration

This procedure must be performed whenever the Laser Unit has been removed or replaced.

The **Color Registration Menu** allows you to adjust the printer's cyan, magenta and yellow against black to ensure that the colors are properly aligned.

You can adjust the settings from -7 to +7 units. (left to right). See the images on the left.

0 is always the printer's current color registration setting.

Print the **Color Registration Page** from the printer's front panel **Troubleshooting** <=> **Print Quality Problems Menu**.

Vertical Color Registration

This adjustment is performed automatically when the Color Registration Page is printed.

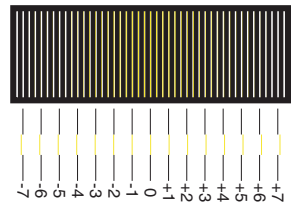
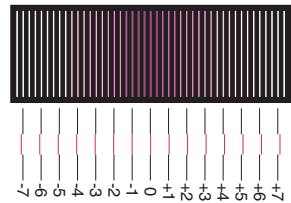
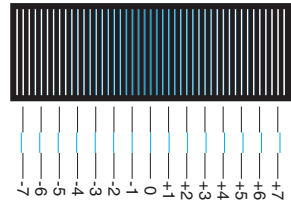

6250-116

Resetting NVRAM

Resetting NVRAM returns all the Image Processor Board NVRAM-stored parameters to their factory default values. The print counts and the Adobe firmware serial number are not affected by this reset. You can reset the PostScript NVRAM using the Customer Menu or the Service Diagnostics Menu.

PostScript NVRAM Resets

Restore Factory Settings (Registration)

1. You can reset settings for color registration to the factory-default values.
2. From the Main Menu, highlight Troubleshooting and press OK.
3. Highlight Print Quality Problems and press OK.
4. Highlight Color Registration and press OK to display Color Registration Menu.
5. Highlight Restore Factory Settings and press OK to reset the color settings to factory defaults.

Restore Factory Settings (Color)

1. You can reset settings for density and color balance to the factory-default values.
2. From the Main Menu, highlight Troubleshooting and press OK.
3. Highlight Print Quality Problems and press OK.
4. Highlight Calibrate Colors and press OK.
5. Highlight Restore Factory Settings and press OK to reset the color settings to factory defaults
6. .Highlight Restore Factory Settings NOW and press OK to reset the color settings to factory defaults.

Restore Previous Settings (Color)

You can return the color settings to the ones that existed before you saved the last color balance adjustments.

1. From the Main Menu, highlight Troubleshooting and press OK.
2. Highlight Print Quality Problems and press OK.
3. Highlight Calibrate Colors and press OK.
4. Highlight Restore Previous Settings and press OK to restore the previous color settings.
5. Highlight Restore Previous Settings NOW and press the OK to reset the color settings to the previously set values.

Restore Factory Settings (Margins)

You can reset margin settings to the factory-default values.

Caution

Use caution when resetting your margins to the factory-default settings. Changing these settings back to factory defaults may not be the last-saved settings if you have previously calibrated your margins.

1. From the Main Menu, highlight Troubleshooting and press OK.
2. Highlight Print Quality Problems and press OK.
3. Highlight Calibrate Margins Menu and press OK.
4. Highlight Restore Factory Settings and press OK to reset the margin settings.

Resetting Connection Setup Defaults

Resetting the Connection Setup values sets TCP/IP address, TCP/IP address menu settings (gateway, broadcast, etc.), CentreWare IS, EtherTalk, Netware, set IPX frame type, IPP, Ethernet speed, Wait Timeout, Page Description Language, and Port selection for both Parallel and USB Ports to their default values.

Caution

Make note of the current network settings or print a configuration page to provide a record of the customer's current network settings before resetting the connection setup to the factory default values.

1. From the Main Menu, highlight Printer Setup and press OK.
2. Highlight Connection Setup and press OK.
3. Highlight Reset Connection Setup and press OK to reset connection defaults.

Resetting Paper Handling Defaults

Resetting the Paper Handling defaults resets the paper source, 2-sided printing, tray setup, load paper timeout, tray sequence, custom units and jam recovery settings to their default values.

1. From the Main Menu, highlight Printer Setup and press OK.
2. Highlight Paper Handling Setup and press OK.
3. Highlight Reset Paper Handling Setup and press OK.
4. Highlight Reset Paper Handling Setup NOW and press OK to reset the paper handling defaults.

Resetting Postscript Setup Defaults

Resetting the Postscript setup values resets Postscript Error Information, Print-Quality Mode, TekColor Correction, and Image Smoothing, to their default values.

1. From the Main Menu, highlight Printer Setup and press OK.
2. Highlight Postscript Setup and press OK.
3. Highlight Reset Postscript Setup and press OK.
4. Highlight Reset Postscript Setup NOW and press OK to reset the postscript defaults.

Resetting PCL Setup Values to Default

Resetting the PCL setup values resets the default font, pitch, size, symbol set, orientation, form length, and line termination settings to their default values.

1. From the Main Menu, highlight Printer Setup and press OK.
2. Highlight PCL Setup and press OK.
3. Highlight Reset PCL Setup and press OK.
4. Highlight Reset PCL Setup NOW and press OK to reset the PCL defaults.

Resetting Front Panel Setup Values to Default

Resetting the Front Panel Setup values resets the front panel language, brightness, contrast and accessibility controls to their default values.

1. From the Main Menu, highlight Printer Setup and press OK.
2. Highlight Front Panel Setup and press OK.
3. Highlight Reset Front Panel Setup and press OK.
4. Highlight Reset Front Panel Setup NOW and press OK to reset the Front Panel defaults.

Resetting Printer Controls Values to Default

Resetting the Printer Controls values resets the startup page, power saver timeout, low toner warning level, date and time, intelligent ready, metric defaults, and power saver to their default values.

1. From the Main Menu, highlight Printer Setup and press OK.
2. Highlight Printer Controls and press OK.
3. Highlight Reset Printer Controls and press OK.
4. Highlight Reset Printer Controls NOW and press OK to reset the Front Panel defaults.

Resetting All Printer Default Settings (PostScript NVRAM)

Resetting the NVRAM restores all printer values stored in the IP controller NVRAM including network, printer setup, job defaults, color, margin, and calibrations to their factory default values. The print counts and the Adobe firmware serial number are not affected by this reset

1. From the Main Menu, highlight Troubleshooting and press OK.
2. Highlight Service Tools and press OK.
3. Highlight Reset NVRAM and press OK.
4. Highlight Reset NVRAM and Reset Printer NOW and press OK to reset all the settings to their factory default values.

Service Diagnostics PostScript NVRAM Resets

Resetting the NVRAM restores all printer values stored in the IP controller NVRAM including network, printer setup, job defaults, color, margin, and calibrations to their factory default values. The print counts and the Adobe firmware serial number are not affected by this reset.

1. Enter Service Diagnostics.
2. Highlight NVRAM Access and press OK.
3. Highlight PostScript NVRAM Reset and press OK.
4. Resetting NVRAM! Are you sure? is displayed. Highlight Yes and press OK.

The printer now exits Service Diagnostics and reboots. While booting, NVRAM is reset.

Cleaning and Maintenance

In this chapter...

- Service Preventive Maintenance Procedure
- Recommended Tools
- Cleaning

Chapter 7



Service Preventive Maintenance Procedure

Perform the following procedures whenever you check, service, or repair a printer. Cleaning the printer, as outlined in the following Steps, assures proper operation of the printer and reduces the probability of having to service the printer in the future.

The frequency of use, Average Monthly Print Volume (AMPV), type of media printed on, and operating environment are factors in determining how critical cleaning the machine is and how often it is necessary. Record the number of sheets printed.

Recommended Tools

- Toner vacuum cleaner
- Clean water
- Clean, dry, lint-free cloth
- Black, light protective bag

Cleaning

Caution

Never apply alcohol or other chemicals to any parts in the printer. Never use a damp cloth to clean up toner. If you remove the Imaging Unit, place it in a light protective bag or otherwise protect it as exposure to light can quickly degrade performance and result in early failure.

1. Record number of sheets printed.
2. Print several sheets of paper to check for problems or defects.
3. Turn off the printer.
4. Remove the Toner Cartridges, Imaging Unit and both side covers before cleaning.
5. Remove the front cover and clean the Fuser Fan with a brush or dry cloth to remove excess dust.
6. Remove the rear cover and clean the Rear Fan with a brush or dry cloth to remove excess dust.
7. Ensure that all cover vents are clean and free of obstructions.
8. Remove any debris or foreign objects from the Transfer Roller, Fuser Assembly, Laser Unit and Imaging Unit.
9. Vacuum any loose toner from the interior of the printer using a Type II toner vacuum only.
10. Open the left side door and clean up any toner inside.

- 11.** Remove and clean the paper trays.
- 12.** Clean all rubber rollers with a clean, lint-free cloth, slightly dampened with cold water.

Service Parts Disassembly

In this chapter...

- Overview
- General Notes on Disassembly
- Removing Routine Maintenance Items and Consumables
- Print Engine Disassembly
- Optional High Capacity Feeder Disassembly
- Optional 500-sheet Feeder Disassembly

Chapter 8

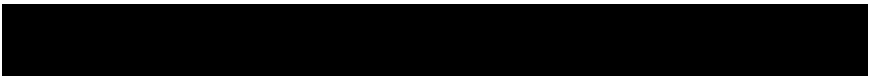

Overview

This section contains the removal and replacement procedures for selected parts of the printer listed in the Parts List. Not all Replacement Procedures are included in this Service Manual. In most cases, the replacement procedure is simply the reverse of the Removal Procedure. In some instances, additional Steps are necessary and are provided for replacement of the parts. For specific assemblies and parts, refer to the "Parts List" on page 9-1.

Standard Orientation of the Printer

When needed, the orientation of the printer is called out in the procedure as an aid to locating printer parts. Refer to the following printer orientation graphic to identify the right, left, front, and back sides of the printer.

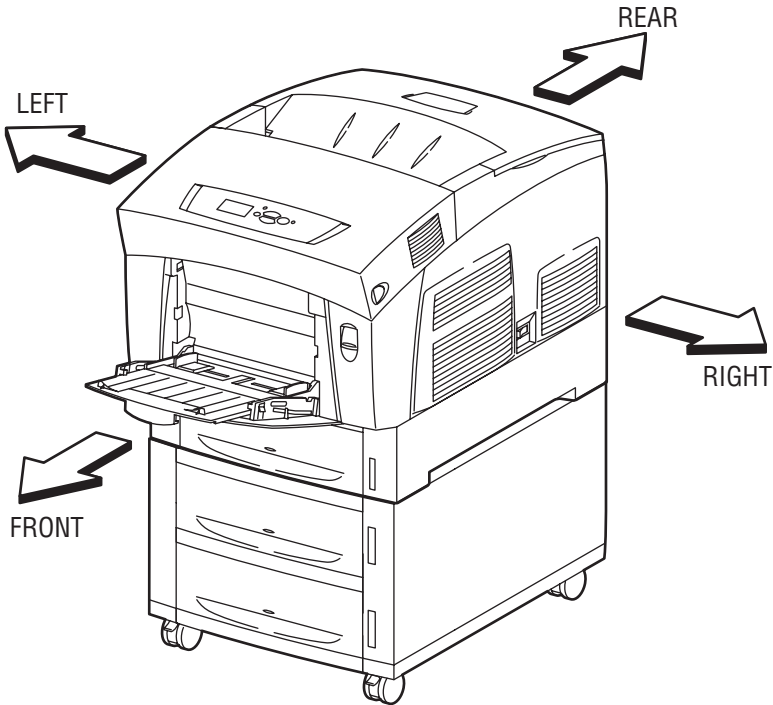

6250-260

General Notes on Disassembly

Preparation

Before you begin any removal and replacement procedure:

1. Switch OFF the printer power and disconnect the power cord from the wall outlet.
2. Remove the Imaging Unit and protect it from exposure to light by covering it with a light proof bag or by placing it in a light-tight container. Disconnect all computer interface cables from the printer.
3. Wear an electrostatic discharge wrist strap to help prevent damage to the sensitive electronics of the printer circuit boards.
4. Remove the Fuser Assembly or wait at least 5 minutes after you have switched OFF printer power for the Fuser to cool before you work on or around the Fuser.

Note

Names of parts that appear in the removal and replacement procedures may not be exactly the same as the names that appear in the Parts List. For example; a part called the Registration Chute Assembly in a removal procedure may appear on the Parts List as Assembly, Chute REGI. When working on a removal and replacement procedure, ignore any prerequisite procedure if you have already removed that part.

Caution

Many parts are secured by plastic tabs DO NOT over Flex or force these parts. Do not over torque the screws threaded into plastic parts.

Always use the correct type and size screw. Using the wrong screw can damage tapped holes. Do not use excessive force to remove or install either a screw or a printer part.

Warning

Unplug the AC power cord from the wall outlet before removing any printer part.

Notations in the Disassembly Text

- The notation “(item X)” points to a numbered callout in the illustration corresponding to the disassembly procedure being performed.
- The notation “PLX.X.X” indicates that this component is listed in the Parts List.
- Bold arrows in an illustration show direction of movement when removing or replacing a component.

Removing Routine Maintenance Items and Consumables

Routine Maintenance Items include the Transfer Roller, Imaging Unit, and Fuser Assembly. The Paper Feed Rollers are also Routine Maintenance Items, but individual procedures for their removal and replacement are provided on page 8-18 and page 8-36. Consumables consist of the four toner cartridges.

Transfer Roller Removal

Warning

If the printer has been in operation recently the Fuser may be hot. Be careful when you release the latches on the Transfer Roller not to come into contact with the hot Fuser.

1. Power down the printer.
2. Open Door A.
3. Squeeze the latch at each end of the Transfer Roller and pivot the latch up.
4. Lift the Transfer Roller out of the printer.

Imaging Unit Removal

1. Power down the printer.
2. Open Door A.
3. Open Door C.
4. Grasp the handle on the top of the Imaging Unit and lift it out of the printer.
5. Place the Imaging Unit in a light proof bag or other light proof container.

Caution

Leaving the Imaging Unit exposed to light for periods in excess of a few minutes can quickly degrade its performance and result in early failure.

Fuser Removal

Warning

The Fuser may be hot. Turn off power and allow at least 5 minutes for the Fuser to cool before removal.

1. Power down the printer.
2. Open Door B.
3. Open Door C.
4. Release the lock on each side of the Fuser, grasp the green handles and lift the Fuser straight up off the mounting studs.

Toner Cartridge Removal

Caution

Clean up any toner spills using a Type II Toner Vacuum only. Never use a damp cloth to clean up spilled toner.

If you are removing a toner cartridge to facilitate removal of other components, replace the toner cartridge as soon as those components have been removed. Keeping the toner cartridges locked into place prevents contamination of the toner system and also prevents spillage.

1. Power down the printer.
2. Using the lips on both sides, lift the Top Cover (Output Tray) off of the printer.
3. Rotate the locking lever on the end of the cartridge (or cartridges) being removed to the back unlocked (closed) position and lift the cartridge out of the printer.

Note

Some toner will probably adhere to the bottom of the cartridge, so do not set the cartridge on any surface that will be damaged by the toner.

Print Engine Disassembly

Dissassembly procedures for the print engine are presented in the following paragraphs and are subdivided by major functional assembly.

Covers

Front Cover (PL 1.1.2)

1. Open Door B.
2. Remove the two front cover retaining clips.
3. Release 4 retainer hooks securing the Front Cover to the Chute Assembly Out.

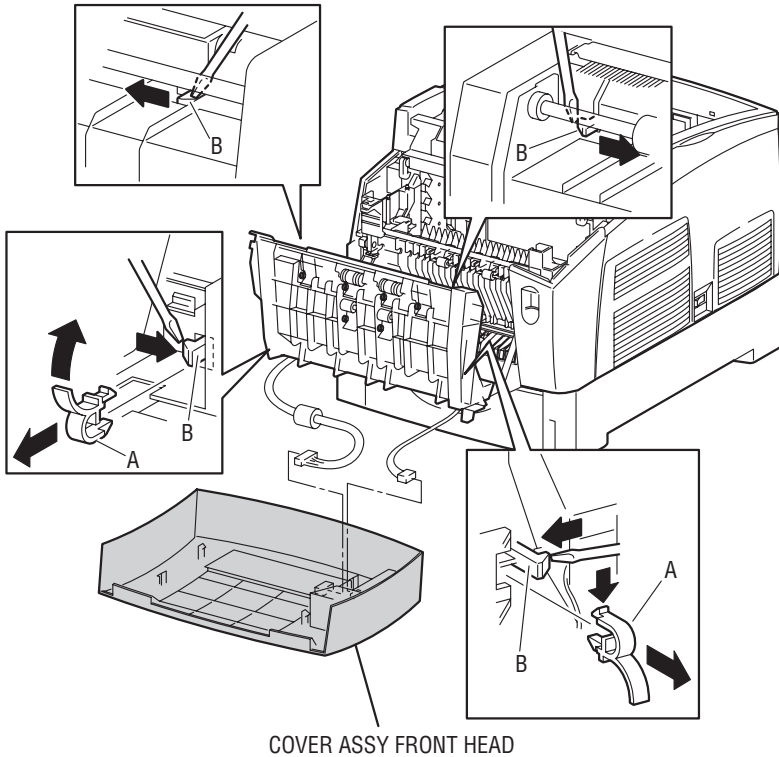

6250-119

Caution

Do not separate the Front Cover from the Chute Assembly Out until the two wiring connectors have been disconnected.

4. Slightly separate the Front Cover from the printer and remove connector P/J220 from the Front Panel and P/J 137 from the Fuser Fan..
5. Remove the Front Cover

Caution

Reinstall the front cover retaining clips (A) as shown when reinstalling the Front Cover.

Front Panel (PL 1.1.1)

1. Remove the Front Cover (1) (page 8-6).
2. Release the 3 hooks securing the Front Panel (2) to the Front Cover and remove the Front Panel.

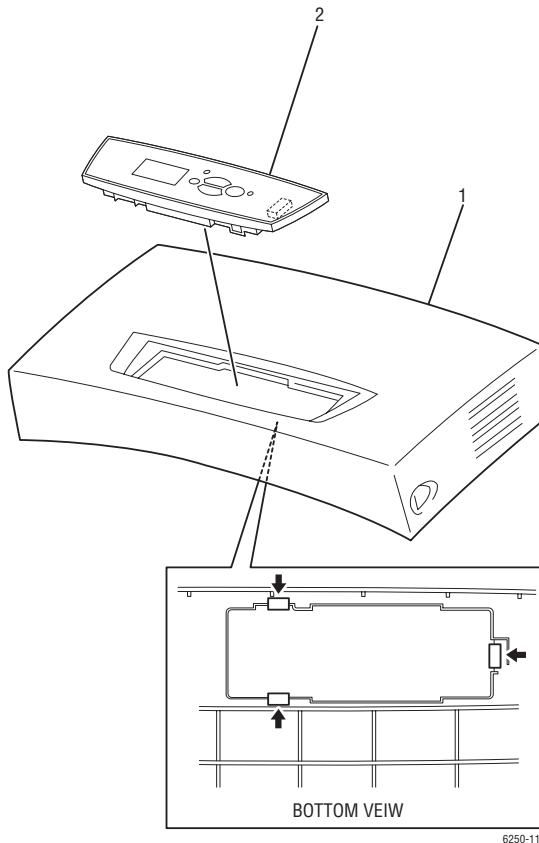

1. Front Cover

2. Front Panel

Fuser Fan (PL 1.1.7)

1. Remove the Front Cover (page 8-6).
2. Remove the 2 screws securing the Fuser Fan Holder (item #1) to the rear of the Front Cover and remove the Fuser Fan Holder.
3. Disconnect P/J137 from the Fuser Fan Holder.
4. Release the 4 tabs securing the Fuser Fan (item #2) to the Fuser Fan Holder and remove the Fuser Fan.

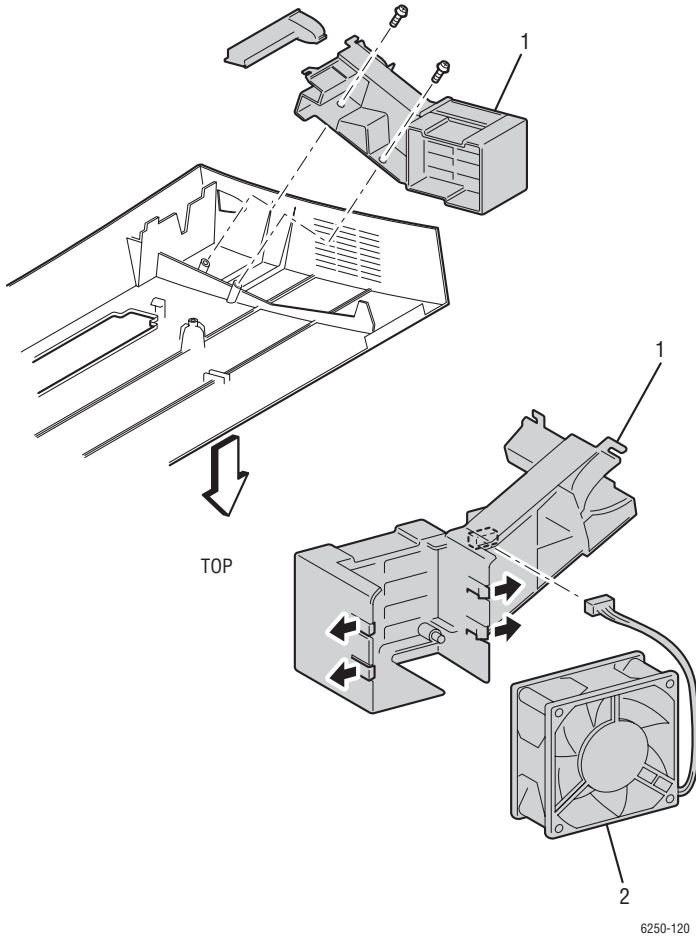

Replacement

1. Assemble in reverse order.

Note

When replacing the Fuser Fan note the airflow direction. The label on the fan should face out.

Top Main Cover (PL1.1.9)

1. Remove the Imaging Unit and protect it from light.
2. Remove all the Toner Cartridges.
3. Open Door A.
4. Open Door C (Top Image Unit Cover PL1.1.10).
5. Remove the 2 screws securing the Top Main Cover (item 1) to the printer.
6. Release the 4 tabs securing the Top Main Cover to the printer.
7. Raise the Top Main Cover slightly from the printer, flexing both the front edges then lift off by moving the cover toward the rear of the printer.

Caution

When the cover is off, reinstall the toner cartridges to prevent contamination of the toner system and spillage of toner.

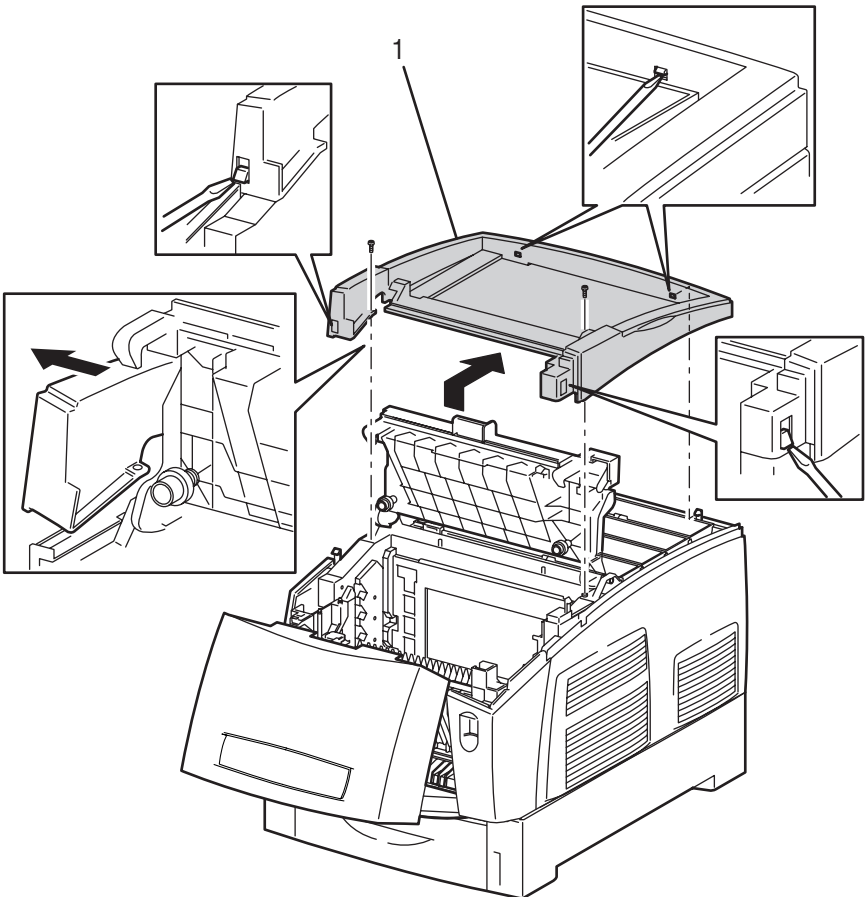

6250-122

Image Unit Top Cover (Door C) (PL1.1.10)

1. Remove the Top Main Cover (page 8-9).
2. Open Door A.
3. Open Door C.
4. Remove the Left Cover (page 8-11).
5. Remove the right and left Stud Top Hinge pins (item #2 PL1.1.21) from the Image Unit Top Cover (item #1) and remove the cover.

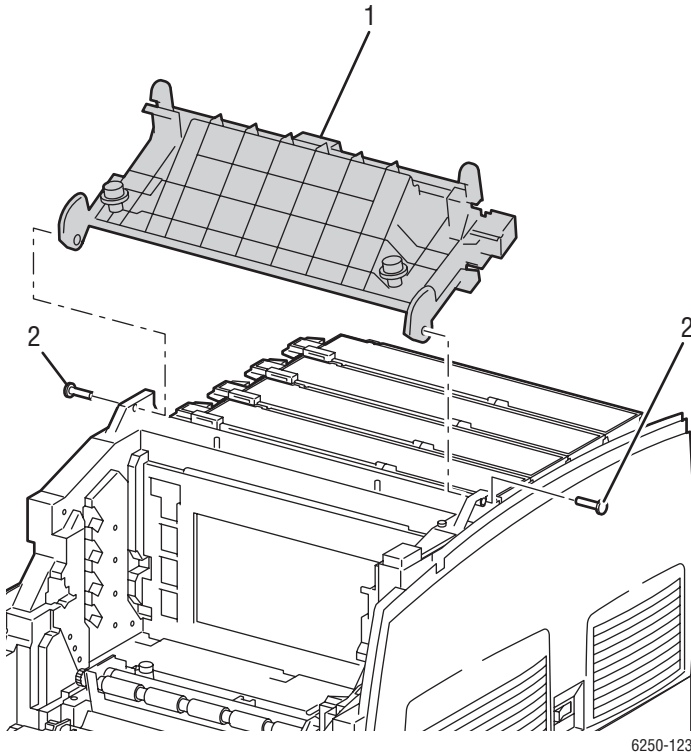

Right and Left Side Covers (PL1.1.24), (PL1.1.30)

1. Remove the Top Main Cover (page 8-9).
2. Remove 1 screw securing the Right Side Cover (item #1) and/or Left Side Cover (item #2) to the printer.
3. Release the tab at the front of the printer securing the Right Side Cover and/or Left Side Cover to the printer.
4. Flex the cover slightly and slide it off to the rear to remove it from the printer.

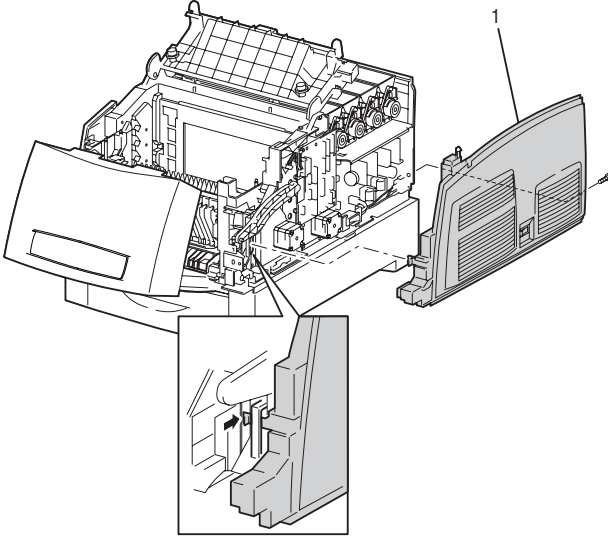

6250-127

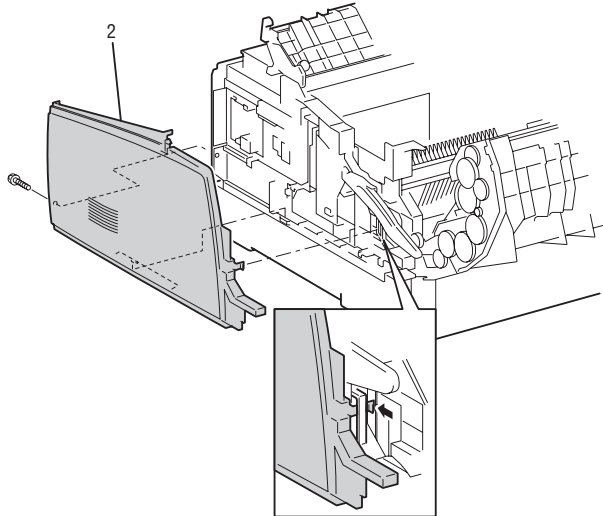

6250-134

Rear Cover (PL 1.1.20)

1. Remove the Right and Left Side Covers. (page 8-11).
2. Raise the Rear Cover(item #1) slightly to release the 7 tabs securing the cover to the printer and remove the cover.

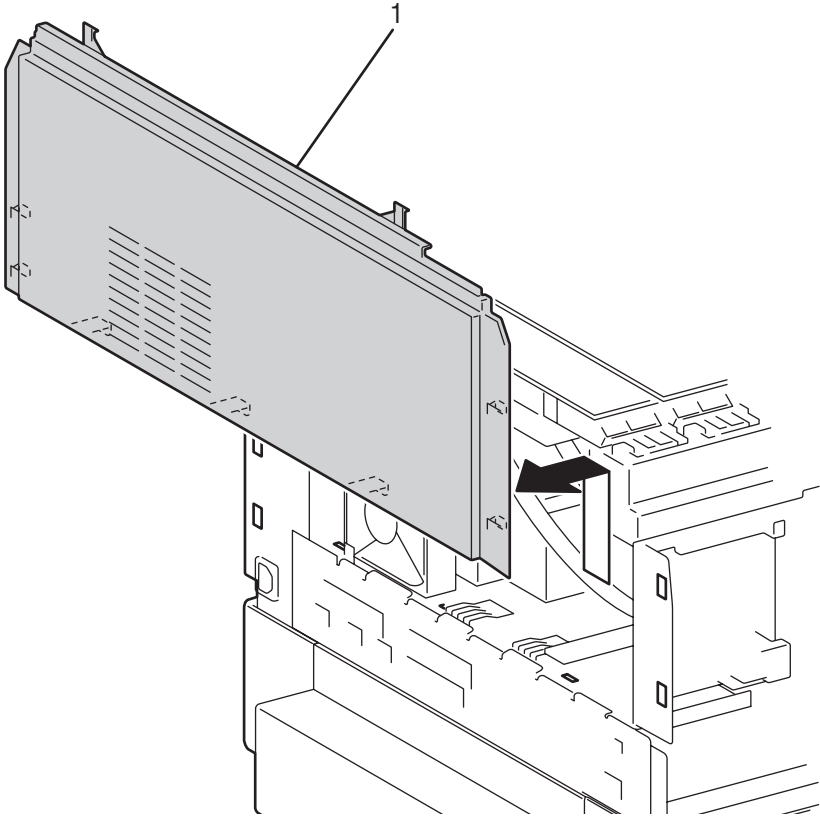

Left and Right Links (PL 1.1.23)

Note

To disengage the links from the printer without removing the link, release the end of the link from the retaining clip and leave the spring connected to the printer.

1. Remove the Right and Left Side Covers (page 8-11).
2. Remove the upper end (eye) of the spring (item #1) from the printer.
3. Open Door A.
4. With a flat blade screwdriver, spread apart both sides of the metal retaining clip holding the Link (item #2) to the Front Cover Assembly and remove the Link and Spring together.

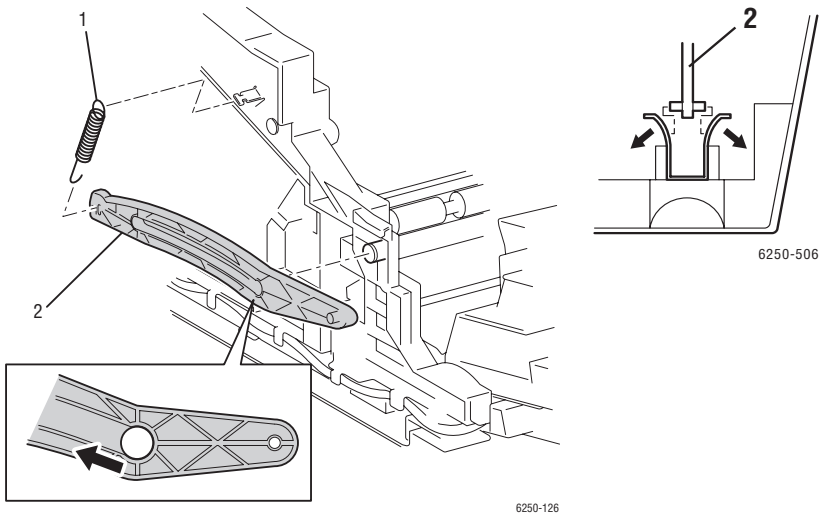
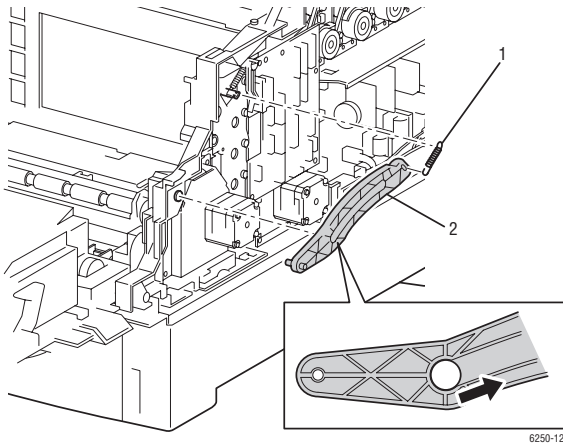

Tray 1 (MPT) (PL1.1.99)

1. Open Tray 1.
2. Flex the right and left side of the Tray 1 Slide (item #1) (PL 1.1.27) to separate the base from the slide.
3. With the Tray 1 Slide at a 90 degree angle, pull the slide out of the printer.
4. To remove the Tray 1 Base (item #2) (PL 1.1.28) from the printer, push down on the center of the Tray 1 Lift Plate, press in on the base, lift up, and pull out from the printer.

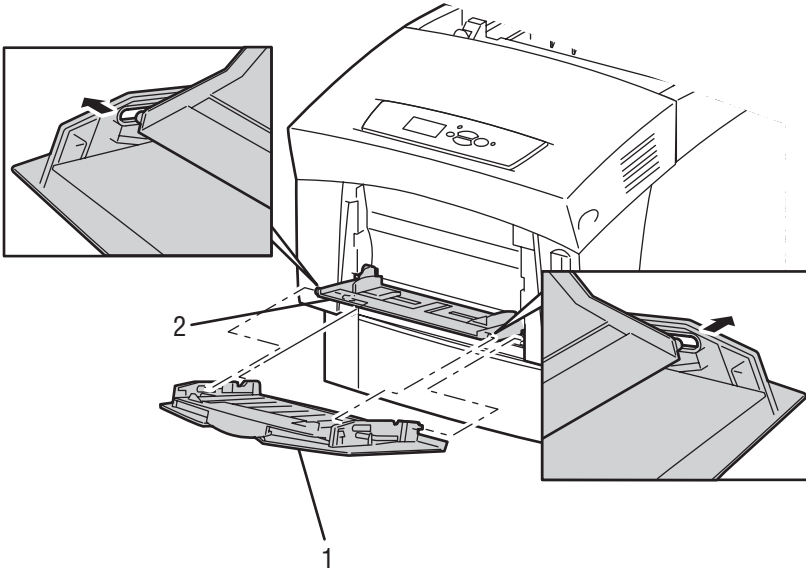

6250-130

Note

The base must be re-installed at a 90 degree angle to align the tabs properly.

5. With the base at a 90 degree angle with the printer and the lift plate pushed down in the center, ensure the tabs are on the outside, push down and then pull forward to re-install.

Front Right Cover (PL 1.1.25)

1. Remove Right and Left Side Covers, see page 8-11.
2. Remove the right side Link Spring (item #3).
3. Open Door A.
4. Remove the link retaining stud and rotate the link out of the way. Then reinsert the stud.
5. Remove the 2 screws securing the Front Right Cover (item #1).

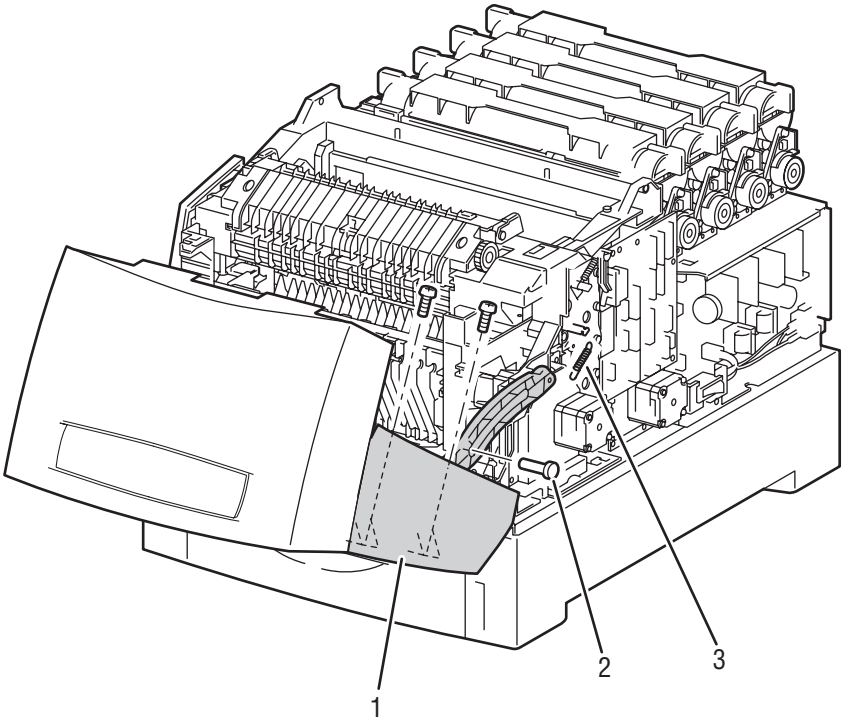

6250-129

6. Remove the Front Right Cover

Front Left Cover Assembly (PL1.1.29)

1. Remove Tray 1 (page 8-14).
2. Remove the Front Cover (page 8-6).
3. Remove the Front Right Cover (page 8-15).
4. Remove the left Link Spring (item #2).
5. Open Door A.
6. Remove the left Link Retaining Stud (item #2), move the Link (item #3) out of the way, and reinstall the Stud.
7. Close Door A.
8. Open Door B.
9. Remove the 2 screws securing the Front Left Cover (item #1) to the Chute Assembly Out.

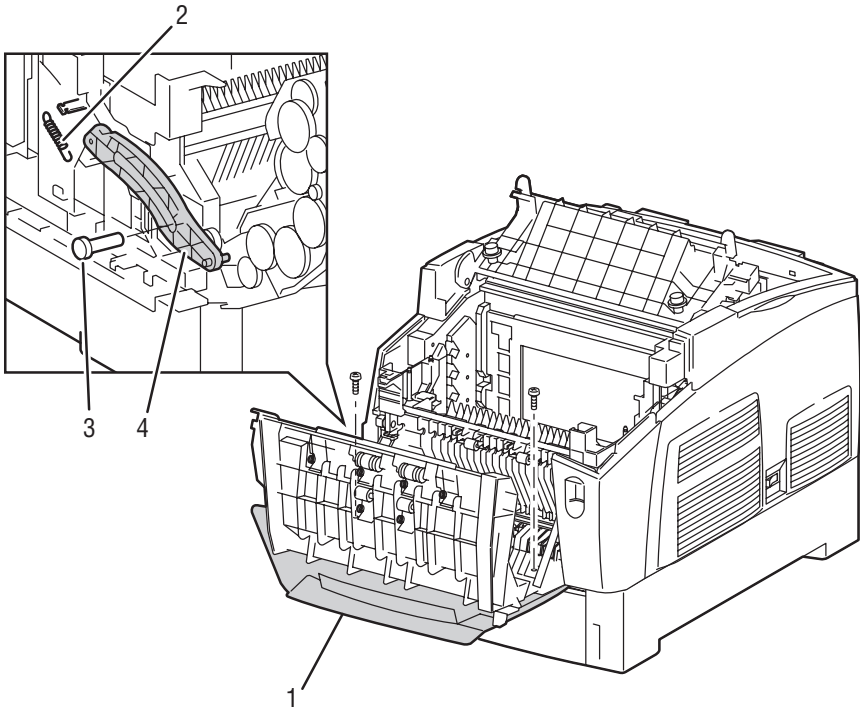

6250-132

10. Release the 2 tabs securing the Front Left Cover to the Chute Assembly Out and remove the Front Left Cover from the printer.

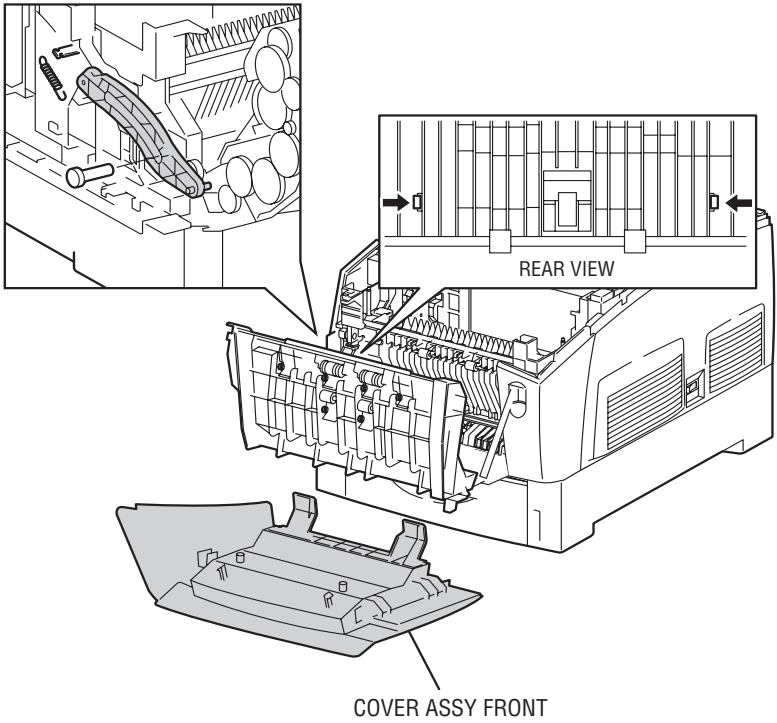

6250-133

Paper Feed

Paper Feed Roller (PL 2.1.2) (Routine Maintenance Item)

1. Pull the paper tray out of the printer.
2. Release the tab securing the Feed Cover to the Paper Tray and open the Feed Cover (item #1).
3. Carefully release the hook securing the Paper Feed Roller (item #2) to the Retard Shaft.
4. Slide the Paper Feed Roller off the shaft to remove.

Note

The Paper Feed Roller Kit contains two rollers. One roller for the Paper Tray and one Roller for the Paper Feeder (PL 3.3.23). The Paper Feed Rollers are interchangeable.

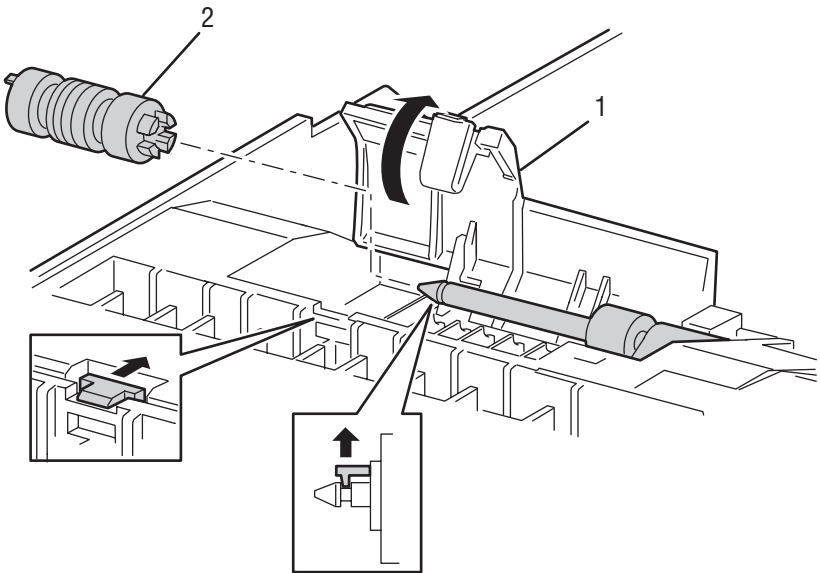

6250-135

Note

When installing the Paper Feed Roller, ensure that the locking tab on the roller locks into the notch on the Retard Shaft as shown in the preceding figure.

Turn Chute Assembly (PL3.1.2)

1. Pull the paper tray out of the printer.
2. Push in on the Turn Chute Assembly (item #1) to release the 2 tabs.
3. Rotate the Turn Chute Assembly 90 degrees downward from the Paper Feeder.

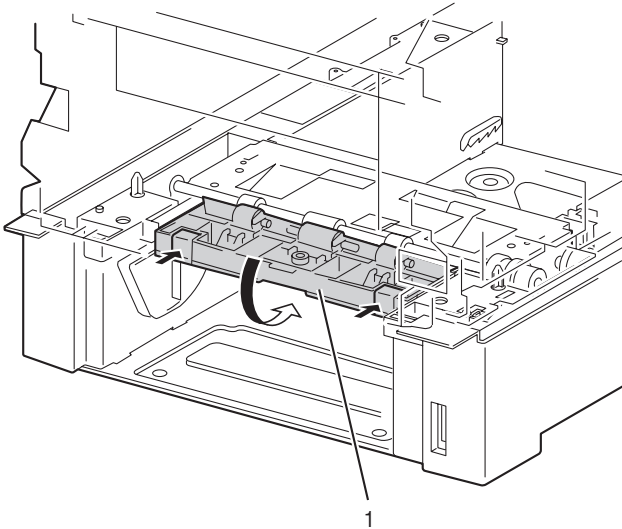

6250-139

4. Release the tabs securing the right and left shaft of the Turn Chute Assembly to the Paper Feeder.
5. Pull out the Turn Chute Assembly from the Paper Feeder to remove.

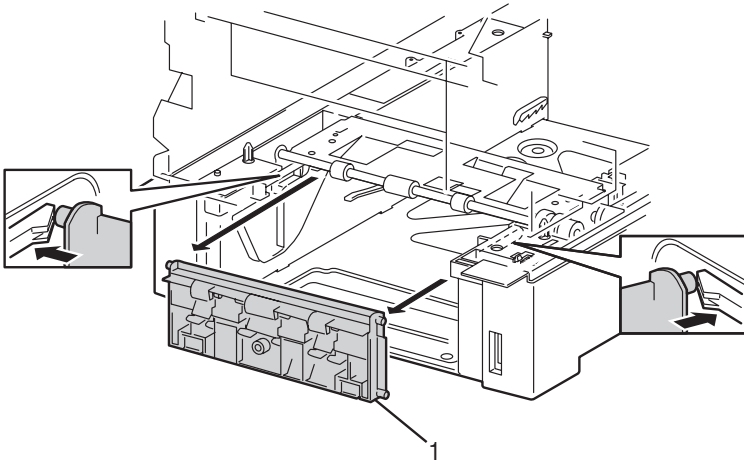

6250-140

Printer Chassis/Feeder Assembly

1. Remove the Imaging Unit and protect it from exposure to light.
2. Remove the Link Actuator (page 8-32).
3. Remove the Top Main Cover (page 8-9).
4. Remove the Right and Left Side Covers (page 8-11).
5. On the left side of the printer, disconnect P/J2361 (gray) from the Printer Chassis.
6. On the right side of the printer, disconnect P/J210 (yellow) from the Printer Chassis.
7. Disconnect P/J47 (yellow/blue) from the Motor Driver Circuit Board on the right side of the printer.

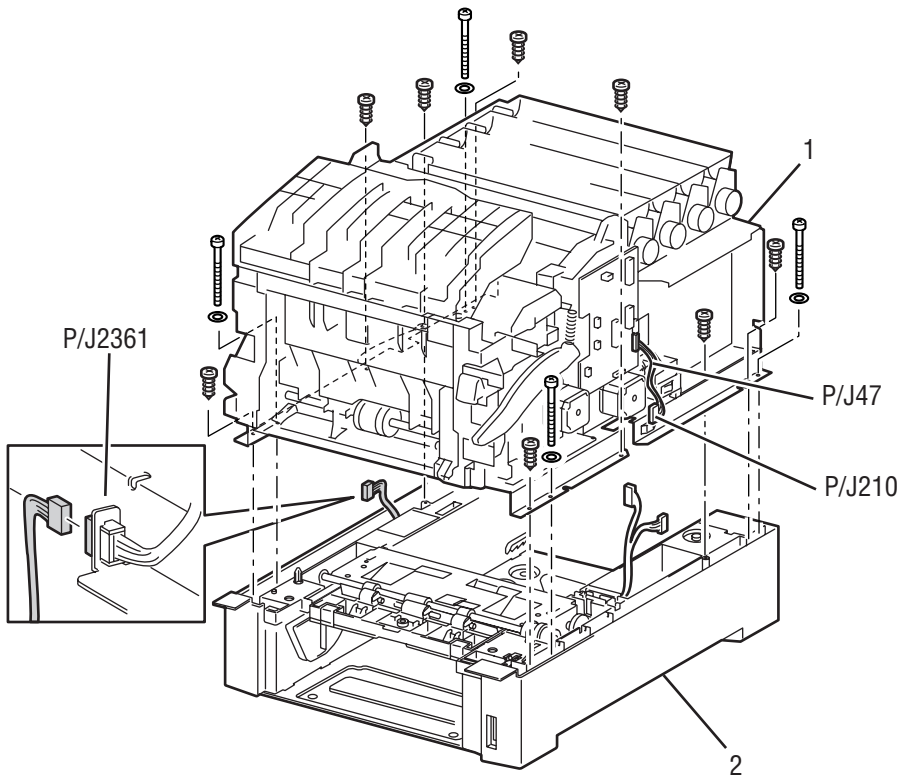

6250-141

8. Remove the 8 short screws securing the Printer Chassis (item #1) to the Feeder Assembly (item #2).

Caution

It is easy to strip the long screws, use caution when removing and replacing.

9. Using a PZ1 Posi bit, remove the 4 long screws securing the Printer Chassis to the Feeder Assembly.

Caution

The washers on the long screws are not captive and can easily be dropped into the chassis during removal or replacement. Be careful not to drop the washers when removing and replacing the long screws.

Caution

Before lifting the Printer Chassis, ensure that harness P/J24 (gray), P/J210 (yellow), and P/J47 (yellow/blue) are positioned to slide through the slots in the chassis bottom plate without catching.

Warning

Lift the Printer Chassis off the Feeder Assembly by placing your hands into the front and back cavity of the paper tray. The right and left sides of the Printer Chassis are extremely sharp.

10. Lift the entire printer chassis off the Feeder Unit Assembly.

Replacement Notes

Caution

When replacing the Printer Chassis ensure that none of the wiring harnesses between the Printer Chassis and Feeder Assembly are pinched.

Paper Pick Assembly (PL3.3.1)

1. Remove the Printer Chassis from the Feeder Assembly (page 8-20).
2. Disconnect P/J471 (yellow) from the Paper Size Switch in the Feeder Assembly.
3. Carefully free the wires (yellow/blue) from their guides, noting the position of the wires for reassembly.
4. Remove the 2 screws securing the Paper Pick Assembly from the Feeder Assembly.
5. Raise the Paper Pick Assembly (item #2) out of the Feeder Assembly (item #1).

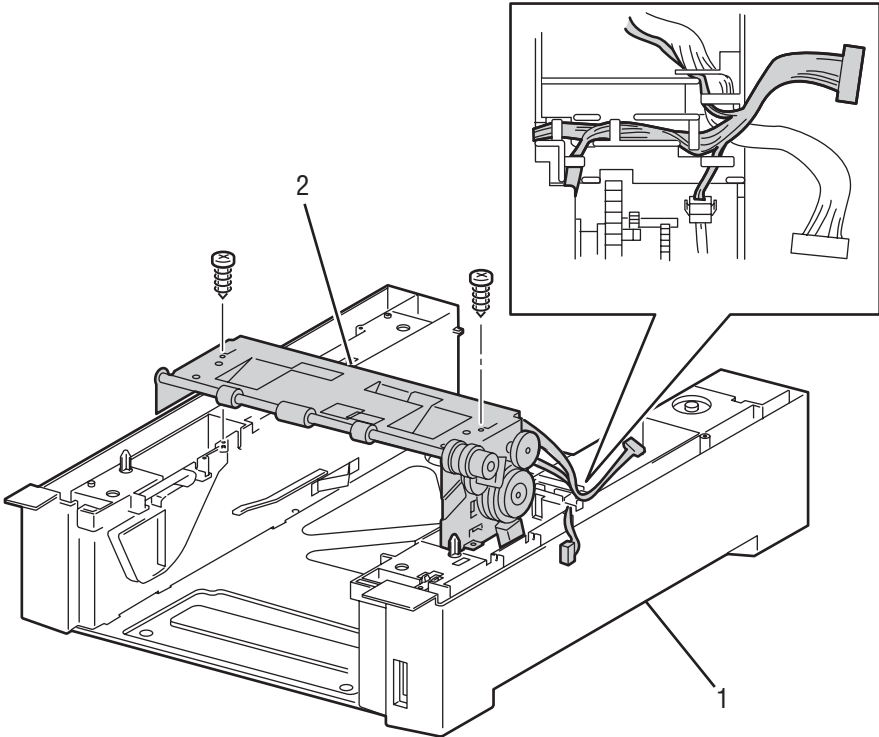

6250-162

Replacement Notes

Caution

Ensure that all wiring is dressed properly and secured under the retaining tabs to prevent damage during reassembly.

Right and Left Housing (PL 3.2)

1. Remove the Paper Pick Assembly (page 8-22).
2. Remove the 4 screws securing the Left/Right Housing to the bottom plate.
3. Lean the top of the housing in slightly towards the center, and release the 3 retaining hooks from the holes in the bottom plate.

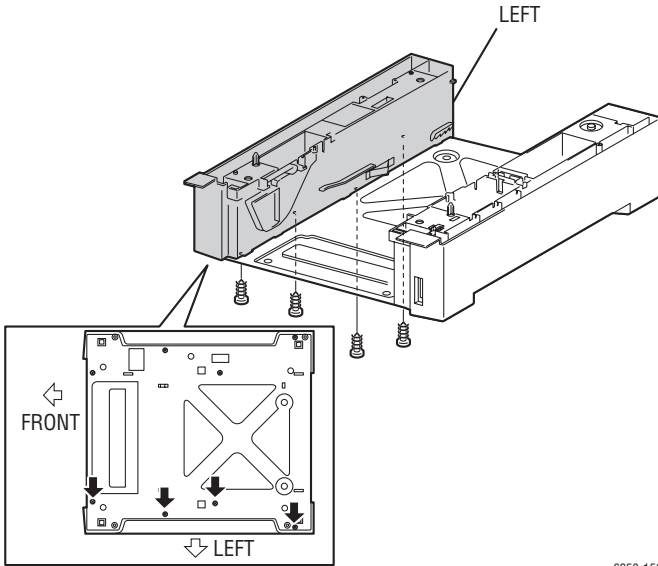

6250-150

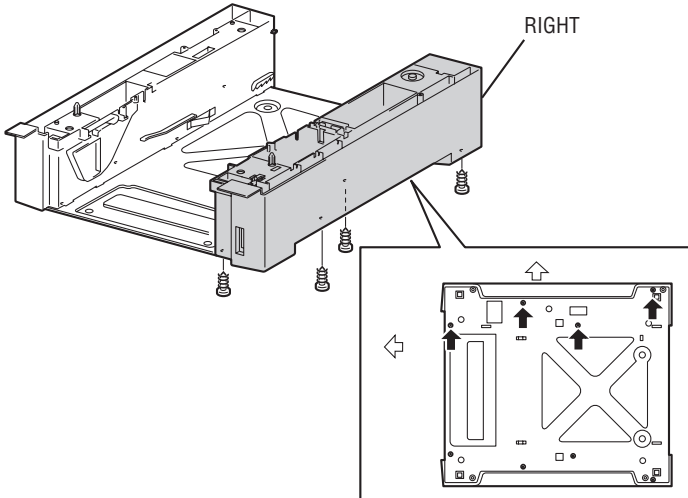

6250-152

Temperature/Humidity Harness (PL3.2.1) and Sensor (PL3.2.2)

1. Remove the Top Main Cover (page 8-9).
2. Remove the Left Side Cover (page 8-11).
3. Disconnect P/J2361 (gray) from the printer.
4. Remove the screw securing the Temperature/Humidity Sensor (item #1) and remove the sensor.

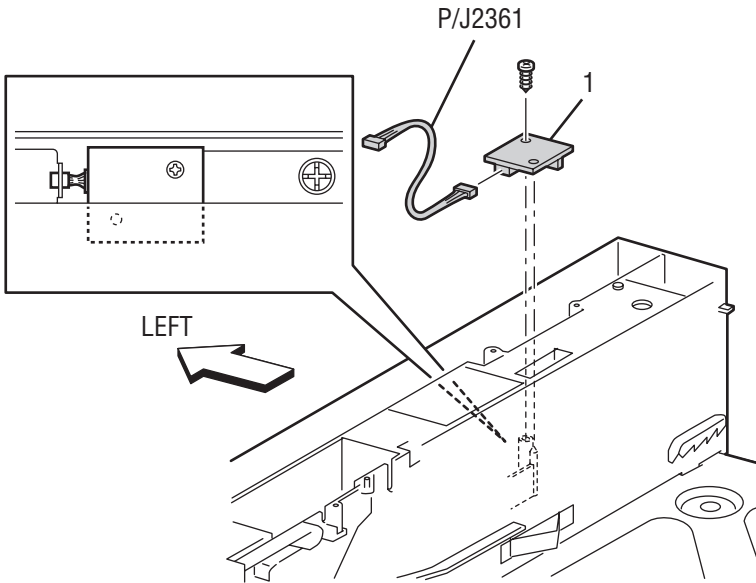

6250-142

Replacement Notes

Note

Seat the sensor onto the Guide Pins with needle nose pliers then re-insert the screw. Reconnect connector P/J2361.

High-Capacity Feeder Harness (PL3.2.3)

1. Remove the Printer Chassis from the Feeder Assembly (page 8-20).
2. Carefully free the HCF Harness (item #1) from the wire guides in the Right Housing.
3. Release the 2 tabs securing the harness connector to the Right Housing.
4. Pull the HCF Harness down from the Right Housing to remove.

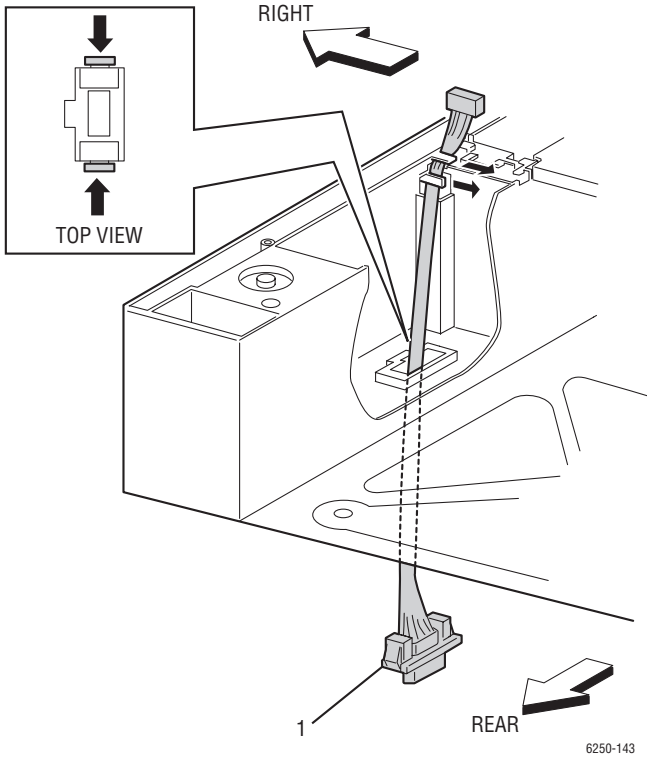

Paper Size Switch Assembly (PL3.2.4)

1. Remove the Printer Chassis from the Paper Feeder Assembly (page 8-20).
2. Disconnect P/J471 from the Paper Size Switch (item #1).
3. Remove 1 screw securing the Paper Size Switch to the Right Housing.
4. Rotate the front of the Paper Size Switch to free the tab and remove.

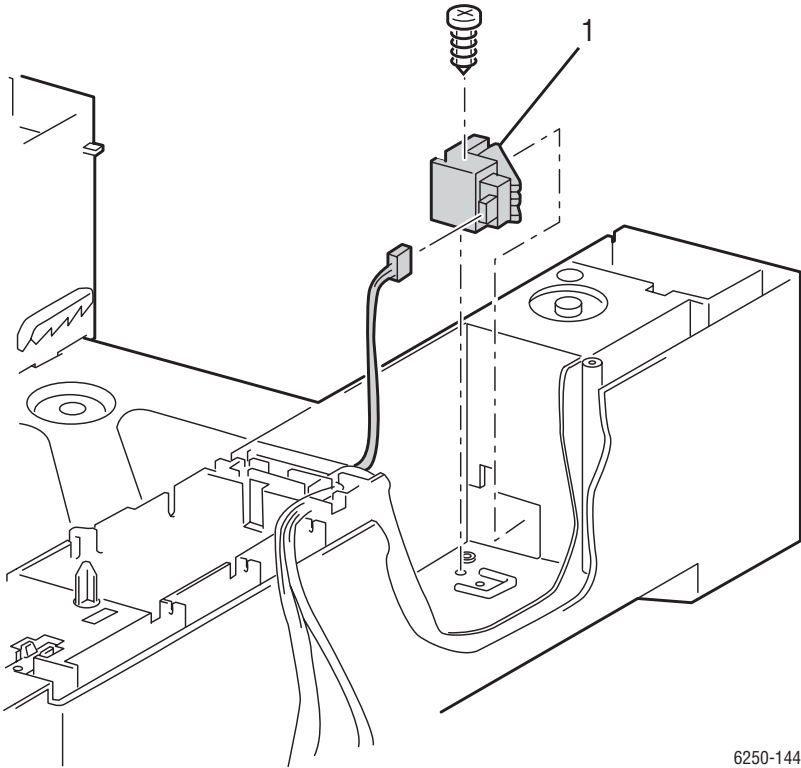

6250-144

Low Paper Lever (PL3.2.7), Indicator (PL3.2.8) and Indicator Guide (PL3.2.10)

Removal - Indicator and Guide Indicator

1. Remove the Printer Chassis from the Paper Feeder Assembly (page 8-20).
2. Remove the Feeder Right Housing (page 8-23).
3. Grasp the tip of the Paper Level Indicator (item #1) using needle nose pliers, and pull the Indicator forward to remove it from the Feeder Right Housing.
4. Release the 2 tabs securing the Shaft Holder (item #5) to the housing.
5. Lift the Shaft Holder, Guide Indicator (item #2) together with the Indicator Spring (item #4) and Shaft Indicator (item #3) out of the housing assembly.

Note

When reinstalling the indicator and guide components, ensure that the Low Paper Lever (item 6) is positioned on top of the Guide Indicator before installing the Paper Level Indicator.

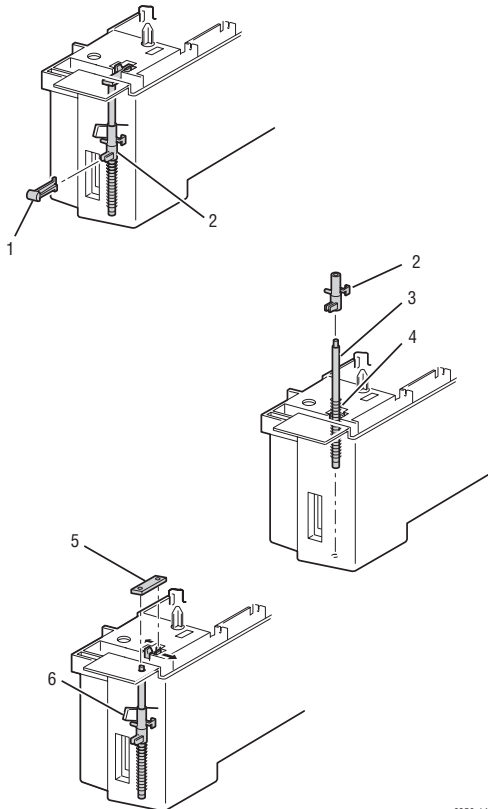

6250-147

Removal - Low Paper Lever

1. Turn the Feeder Right Housing upside down.
2. Push the vertical retainer, securing the right end of the Low Paper Lever towards the outside of the housing while pulling the lever upwards.
3. When the right end releases, pull the left end free of the retaining hole in the inside wall of the housing.
4. Push the actuator end of the Low Paper Lever (item #1) through the slot in the inside wall of the Feeder Right Housing (item #2) then raise the lever up and out of the feeder.

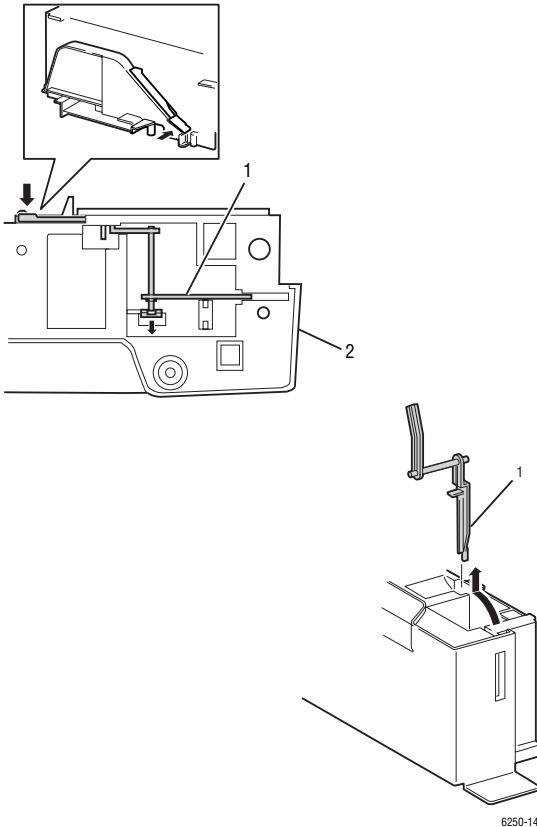

6250-145

Replacement Notes

Note

Put the front end of the low paper lever on top of the left (round) arm of the Guide Indicator when replacing the Guide Indicator. Hold the Guide Indicator securely when replacing the Paper Level Indicator.

Paper Pick Rollers (PL3.3.3)

1. Pull the paper tray out of the printer.

Note

Remove and replace the Paper Pick Rollers (item #1) one at a time to maintain the proper orientation.

2. Remove the Turn Chute Assembly (page 8-19).
3. Rotate the Feed Shaft so that the rubber surface of the Paper Pick Rollers faces down.
4. Pull the Paper Pick Roller off the shaft.

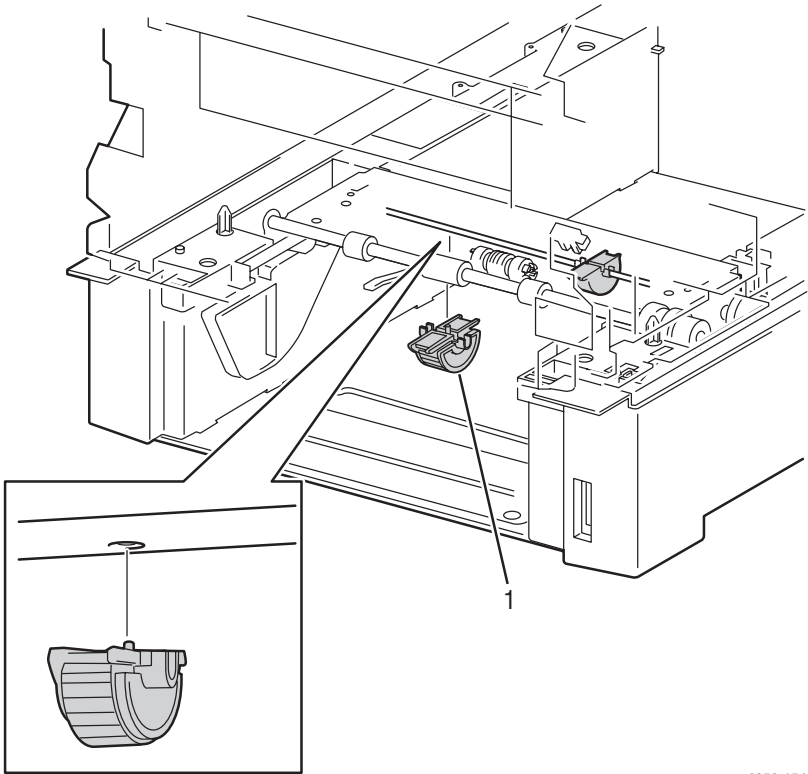

6250-154

No Paper Actuator (PL3.3.5), No/Low Paper Sensor (PL3.3.4)

Removal - Actuator

1. Remove the Printer Chassis from the Paper Feeder Assembly (page 8-20).
2. Remove the Paper Pick Assembly (page 8-22) and turn it upside down.
3. Release the hook securing the No Paper Actuator (item #1) to the Paper Pick Assembly and extract the left end of the shaft.
4. Pull the No Paper Actuator out and up to remove.

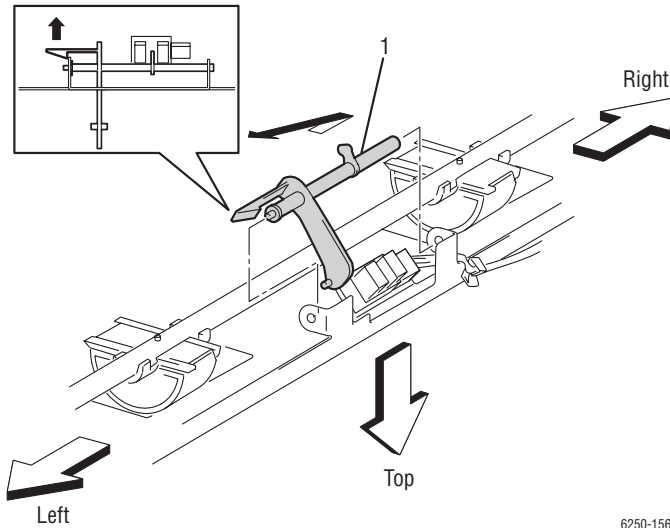

6250-156

Removal - No Paper Sensor

Note

The sensors are interchangeable.

1. Remove the right Paper Pick Roller to gain access to the P/J472 (blue).
2. Disconnect P/J472 (blue) from the No Paper Sensor (item #1).
3. Lift up on the clear plastic lock to release 3 tabs securing the No Paper Sensor to the Paper Pick Assembly and remove the No Paper Sensor.

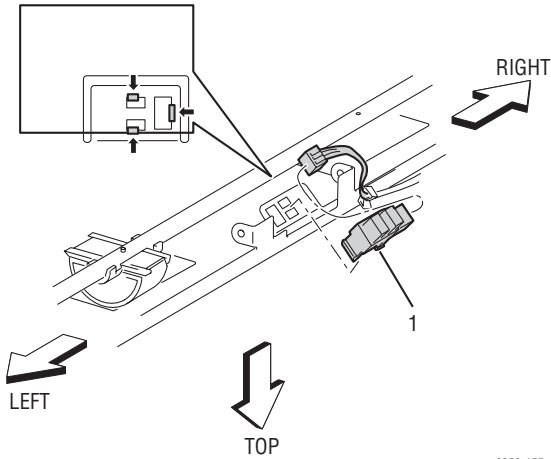

6250-155

Removal - Low Paper Sensor

1. Disconnect P/J473 (yellow) on the Low Paper Sensor.
2. Release 3 tabs securing the Low Paper Sensor to the Paper Pick Assembly and remove the sensor.

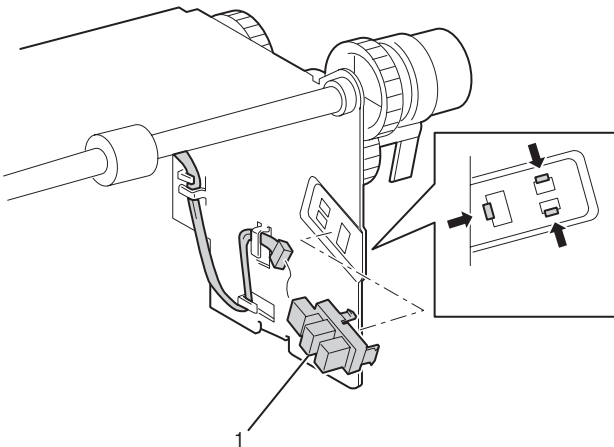

6250-158

Link Actuator (PL3.3.6)

Note

Perform this procedure from the rear of the printer.

1. Pull the paper tray out of the printer.
2. Remove the paper tray Rear Cover by pushing in on the left side until the cover comes off the left mounting tab, then remove it from the right tab.
3. Reach in through the rear of the printer and spread the tabs of the Link Actuator (item #1) apart and disconnect it from the Actuator No Paper (item #2).
4. Remove the link actuator from the bracket in the printer and remove.

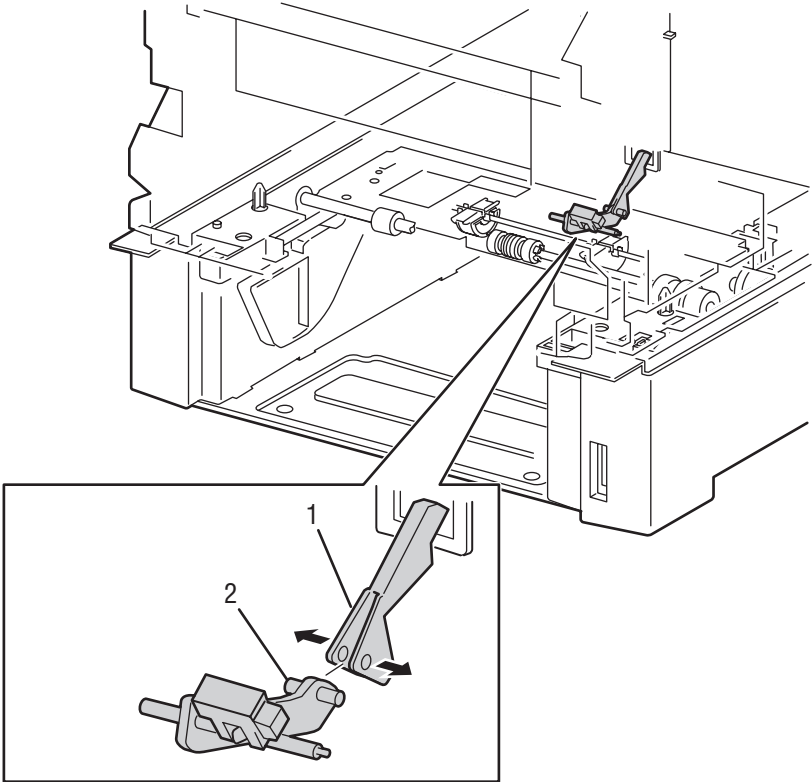

6250-157

Feed Solenoid (PL3.3.17)

1. Remove the Printer Chassis from the Paper Feeder Assembly (page 8-20).
2. Remove the Paper Pick Assembly (page 8-22).
3. Remove 1 screw securing the Feed Solenoid to the Paper Pick Assembly.
4. Separate the Feed Solenoid slightly and shift the harness to disconnect P/J474 (gray).
5. Remove the Feed Solenoid.

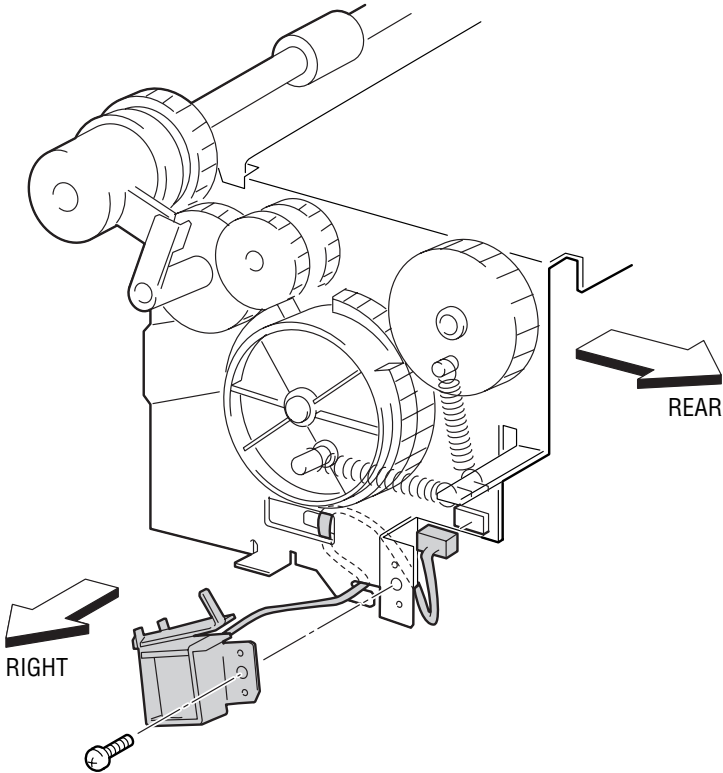

6250-159

Turn Clutch Assembly (PL3.3.18)

1. Remove the Printer Chassis from the Paper Feeder Assembly (page 8-20).
2. Remove the Paper Pick Assembly (page 8-22).
3. Release the tab securing the Stopper Clutch (item #2) to the shaft on the right side of the Paper Pick Assembly.
4. Pull out the Stopper Clutch.
5. Disconnect P/J475 (blue) from the Turn Clutch Assembly.
6. Pull out the Turn Clutch Assembly (item #1).

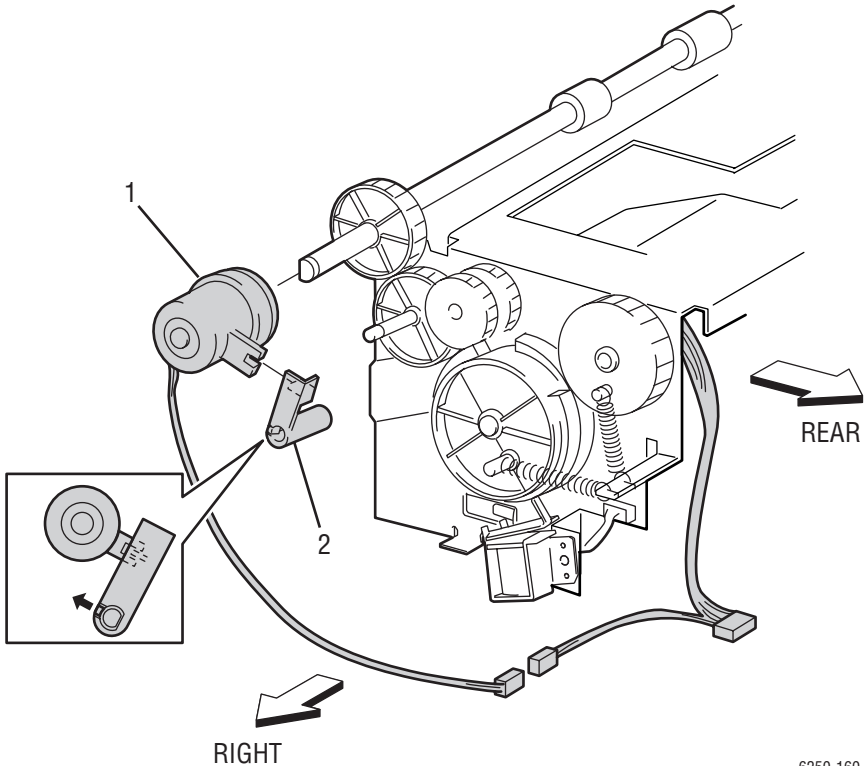

6250-160

Roll Turn Assembly (PL3.3.20)

1. Remove the Printer Chassis from the Paper Feeder Assembly (page 8-20).
2. Remove the Paper Pick Assembly (page 8-22).
3. Remove the Clutch Turn Assembly (page 8-34).
4. Release the tab securing the Gear Feed 2 (item 2#) to the shaft of the Paper Pick Assembly and pull out the Gear Feed 2.
5. Pull out the Idler Gear (item #1) and Idler Gear In (item #3) from the Paper Pick Assembly.
6. Remove the right and left e-rings securing the shaft of the Roll Turn Assembly to the Paper Pick Assembly.
7. Remove the metal bearing (item #6) securing the right shaft end of the Turn Roll Assembly.
8. Remove the black bearing (item #4) securing the left shaft end of the Roll Turn Assembly.
9. Remove the shaft (item #5) from the Paper Pick Assembly.

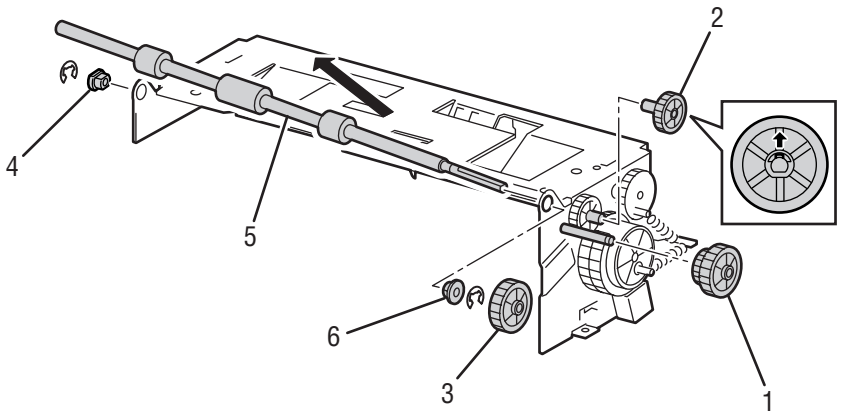

6250-161

Replacement Notes

Note

Ensure that metal bearing is replaced on the clutch end of the shaft.

Paper Feed Roller (Routine Maintenance Item)

1. Pull paper tray out of the printer.
2. Release 1 tab securing the Paper Feed Roller (item #1) to the feed shaft (item #2).
3. Slide the Paper Feed Roller off the left side of the feed shaft.

Note

The Paper Feed Roller Kit contains two rollers. One roller for the Paper Tray and one Roller for the Paper Feeder Assembly (PL 3.3.23). The Paper Feed Rollers are interchangeable.

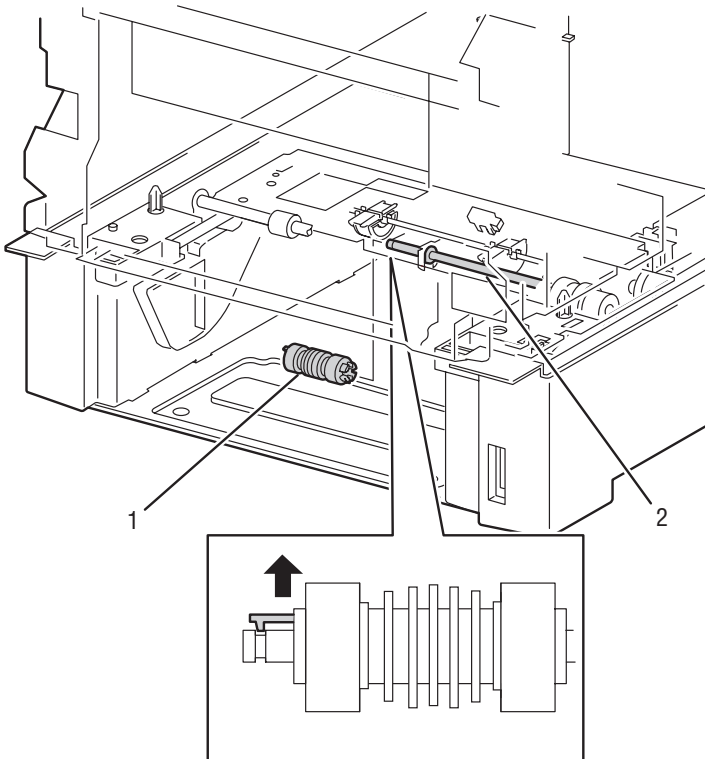

6250-237

Retard Roller Housing Assembly (PL4.1.1)

1. Remove the Registration Chute Assembly (page 8-71).
2. Disconnect P/J19 (blue) from the Engine Control Board.
3. Remove the 3 screws securing the Retard Roller Housing Assembly to the printer, lift the left end, and remove the assembly to the left.

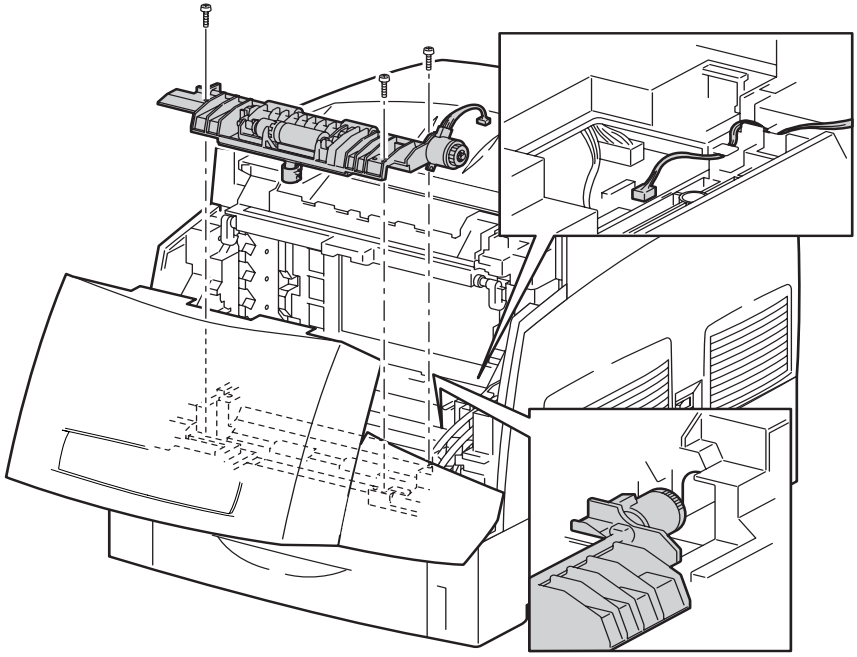

6250-163

Turn Roll (PL 4.1.2), Turn Clutch (PL 4.1.9), and Friction Clutch Assembly (PL 4.1.4)

1. Remove the Retard Roller Housing Assembly (page 8-37)
2. Remove the e-ring securing the Turn Clutch (item #1) to the shaft and remove the clutch.
3. Remove the e-ring securing the left end of the Turn Roll shaft (item #2) to the Retard Roller Housing Assembly (item #3) .
4. Remove the metal (item #4) and plastic (item #5) bearings.
5. Slide the shaft to the right and remove to the left of the assembly.

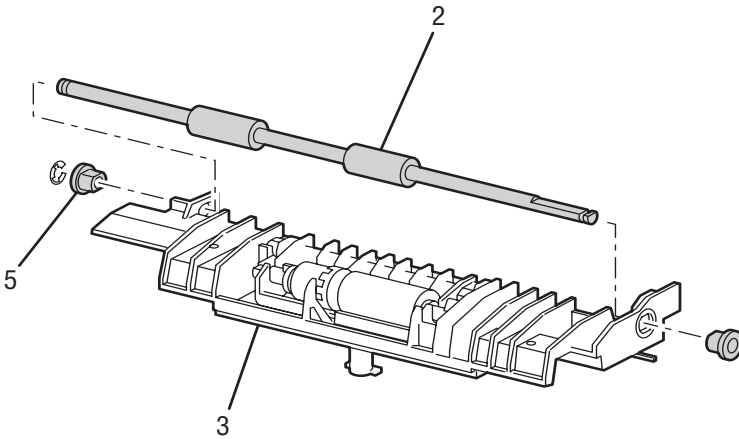

6250-164

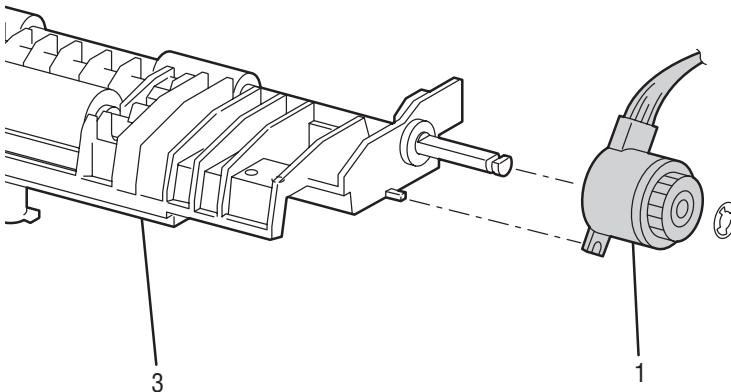

6250-167

Replacement Notes

Note

Ensure that metal bearing is replaced on the clutch end of the shaft.

Retard Roller Assembly (PL4.1.5)

1. Open Door A and Door C.
2. Remove the Imaging Unit and protect it from exposure to light.
3. Rotate the Retard Roller Assembly (item #1) up, slide to the right and remove to the left of the printer.

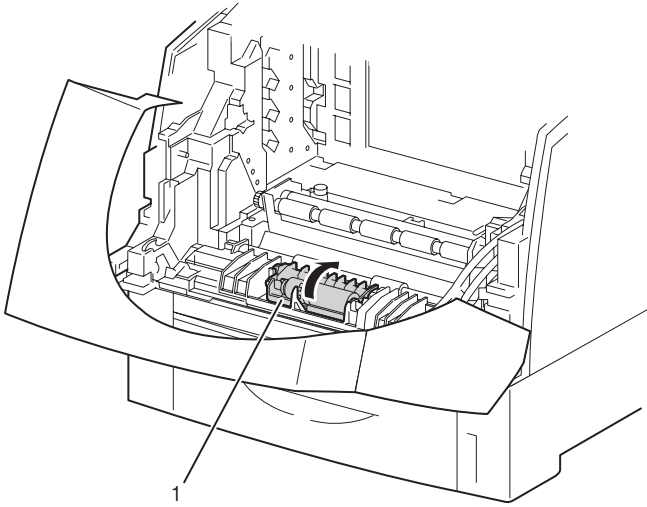

6250-245

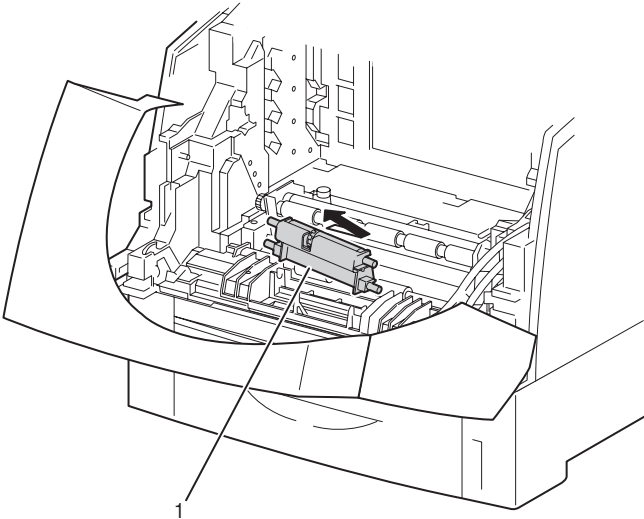

6250-246

4. Release the tab securing the Retard Roller Shaft (item #2), raise the right end and remove the Retard Roller.

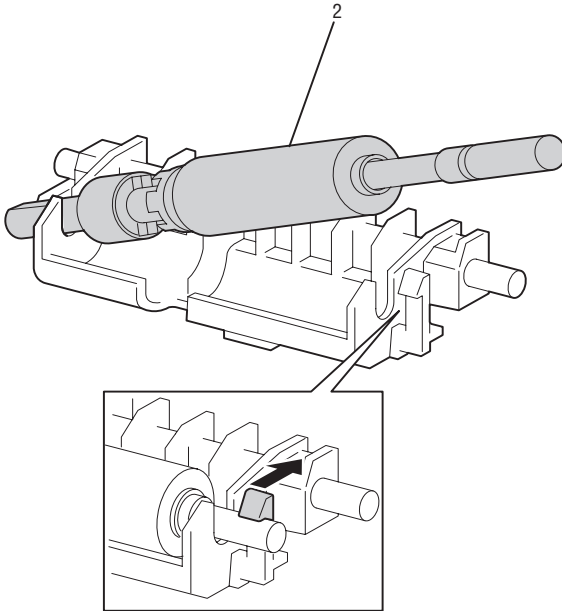

6250-166

Chute Assembly In

Chute Assembly In (PL 5.1.1)

1. Remove the Chute Assembly Out (page 8-47).

Note

P/J162 is located behind the Motor Driver Board cable retainer. Release the retainer from the chassis to access the connector.

2. On the right side, remove P/J162 from the LVPS board.
3. Remove 1 screw securing the ground wire (green) to the right side of the chassis.
4. Carefully remove the harness items in the previous Steps from the wire guides along the bottom right side of the chassis.

Caution

Remove the Chute Assembly In slowly and carefully, ensuring that the wiring harness does not catch and sustain damage during removal.

5. Release latch A (Door A) and pull the Chute Assembly In forward to remove it from the printer chassis.

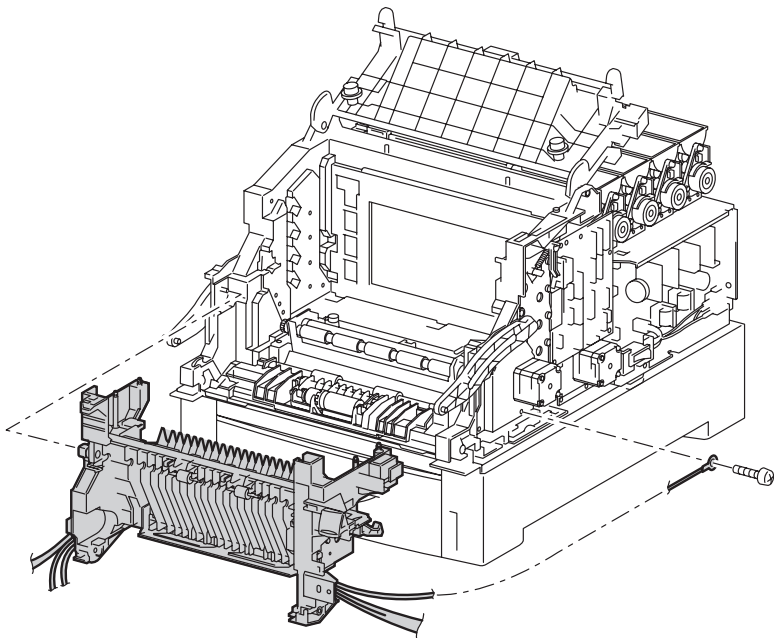

6250-169

CTD (ADC) Sensor (PL 5.1.11)

1. Open Door A.
2. Remove the Transfer Roller Assembly (Routine Maintenance Item) (page 8-4).
3. Release the 4 tabs securing the CTD Sensor Assembly (item #1) to the Chute Assembly In (item #2).

Caution

The CTD Sensor is under spring tension, be careful not to damage or lose the springs.

4. Raise the sensor slightly to disconnect P/J136 (yellow) from the Chute Assembly In.
5. Remove the CTD Sensor.
6. Remove the springs (item #3) from the Sensor CTD (ADC) Assembly.

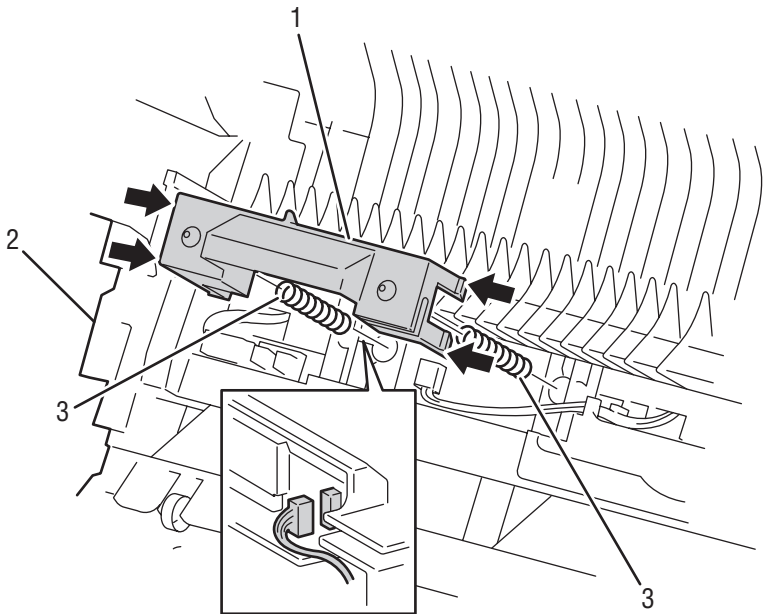

6250-170

Replacement Notes

Note

The left spring has an aligning post on the Chute Assembly In.

Toner Full Sensor (PL 5.1.13)

1. Open Door A.
2. Remove the Transfer Roller Assembly (Routine Maintenance Item) (page 8-4).
3. Disconnect P/J142 from the Chute Assembly In.
4. Release 2 tabs securing the Toner Full Sensor with a small screwdriver.
5. Remove the Toner Full Sensor from the Chute Assembly In.

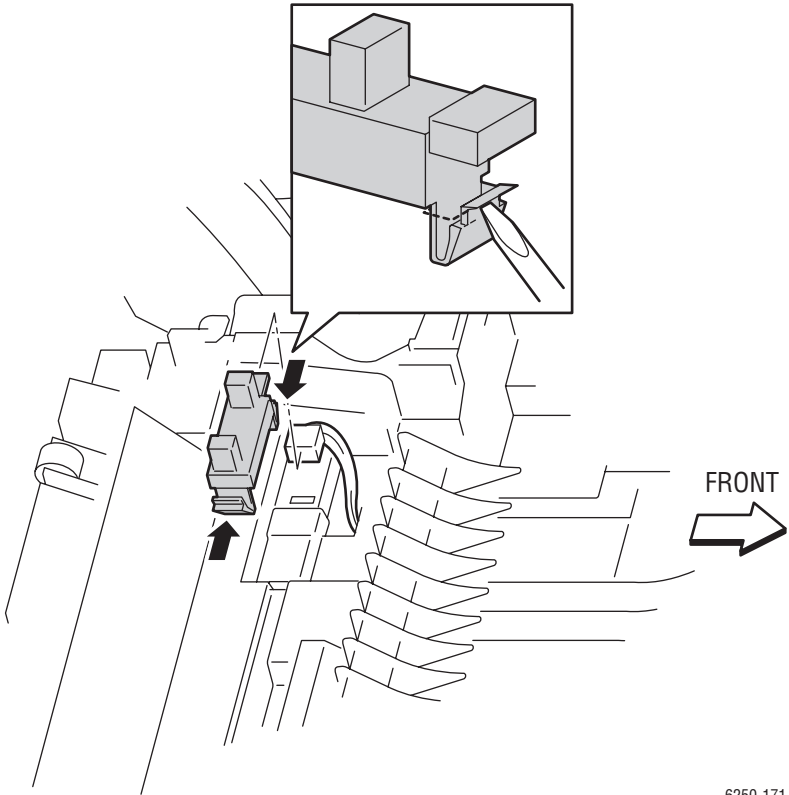

6250-171

Fuser Drive Assembly (PL 5.1.18)

1. Remove the Chute Assembly Out (page 8-47).
2. Remove the Chute Assembly In (page 8-41).
3. Remove Right Latch (Door A) (page 8-45).
4. Remove the 1 screw securing the fuser ground wire to the Fuser Drive Assembly.
5. Carefully remove the harness attached to the Fuser Drive Assembly from the cable guides in the Chute Assembly In housing.
6. Remove the 3 screws securing the Fuser Drive Assembly to the Chute Assembly In.
7. Remove the Fuser Drive Assembly.

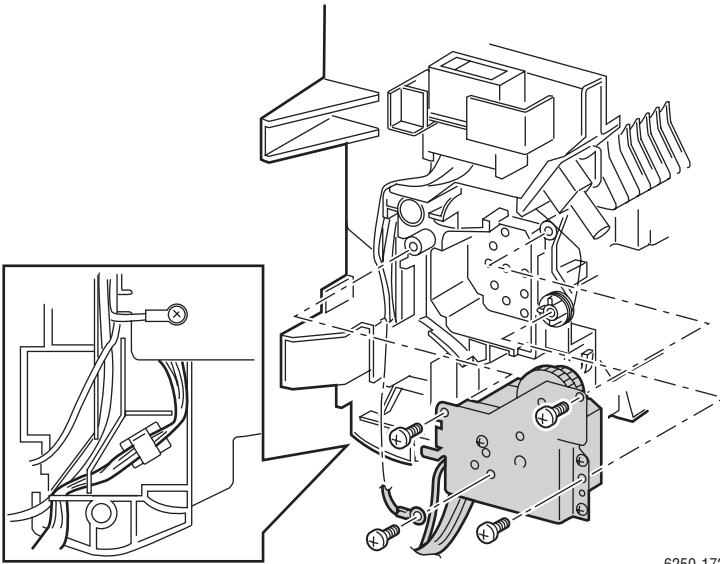

6250-172

Replacement Notes

Note

Note the routing of the wires for reassembly

Right Latch (Door A) (PL 5.1.21)

1. Remove the Fuser Assembly (Routine Maintenance Item) (page 8-5).
2. Remove the Front Right Cover (page 8-15).
3. Open Door A.
4. Release the hook on the lower part of the spring (item 4) securing it to the Chute Assembly In.
5. Release the tab securing Right Latch (item 3) to the Chute Assembly In.
6. Remove Right Latch from the Latch Shaft (item 2).

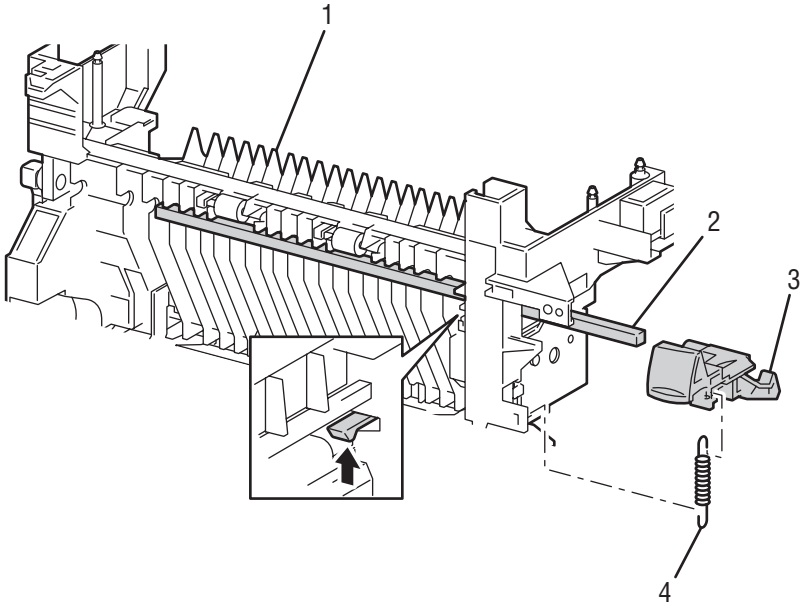

6250-173

Left Latch (PL 5.1.30)

1. Remove the Fuser Assembly (page 8-5).
2. Remove the Front Left Cover (page 8-16).
3. Open Door A.
4. Release the tab securing Left Latch (item #2) to the left side of the Chute Assembly In.
5. Remove the Left Latch from the Latch Shaft.

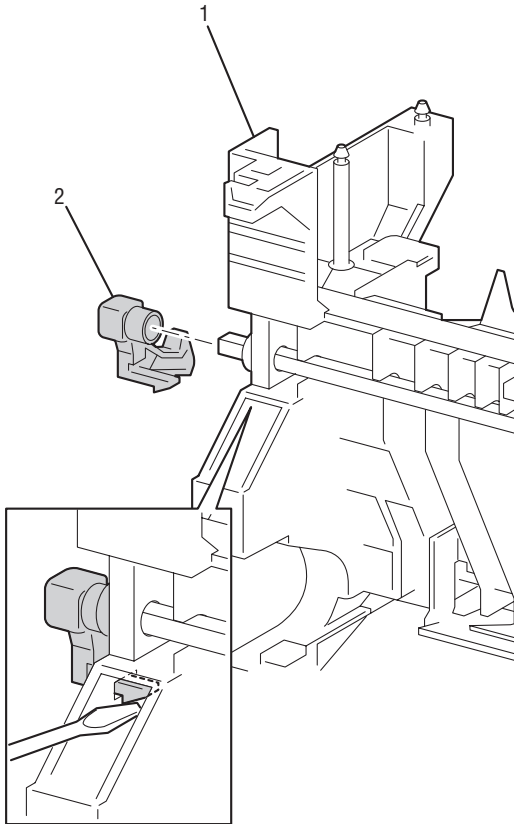

6250-174

Chute Assembly Out

Chute Assembly Out (PL6.1.1)

1. Remove the Imaging Unit (Routine Maintenance Item) (page 8-4) and protect it from exposure to light.
2. Remove the Transfer Roller (Routine Maintenance Item) (page 8-4).
3. Remove the Fuser Assembly (Routine Maintenance Item) (page 8-5).
4. Remove all Covers and Tray 1 (page 8-6, page 8-9, page 8-11, page 8-12, page 8-14, page 8-15, and page 8-16).

Caution

Support the Chute Assembly Out (Door B) while removing the strap to prevent damage to the printer.

5. Remove the strap (page 8-67).
6. Close the Chute Assembly Out (Door B) and the Chute Assembly In (Door A) while disconnecting wiring harnesses to avoid damaging the printer.
7. Disconnect all connectors going to the front of the left side connector block.
8. Disconnect the lower (grey) connector (P/J145) from the EEPROM board.
9. Disconnect the two red wired spade lug connectors (P/J5020 and P/J5030) from the Sub-HVPS board.
10. Remove 1 screw securing the ground wire to the left side of the printer.
11. Free the harness from the wire guides at the bottom of the Housing Assembly.

12. On the right side of the printer, disconnect P/J50 and P/J52 from the Motor Driver Board .

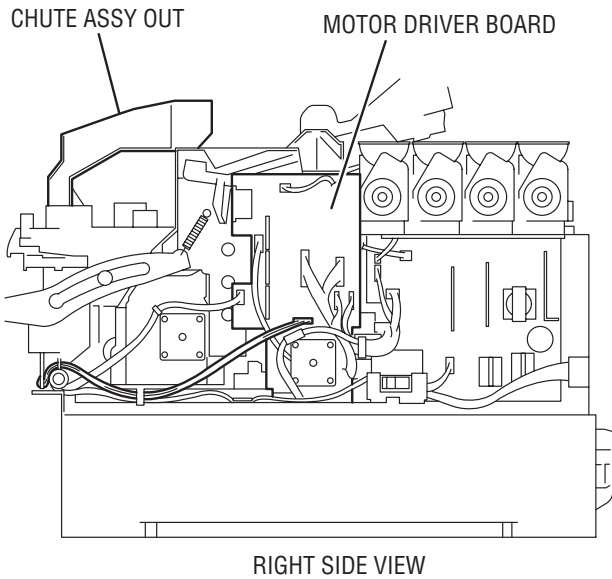
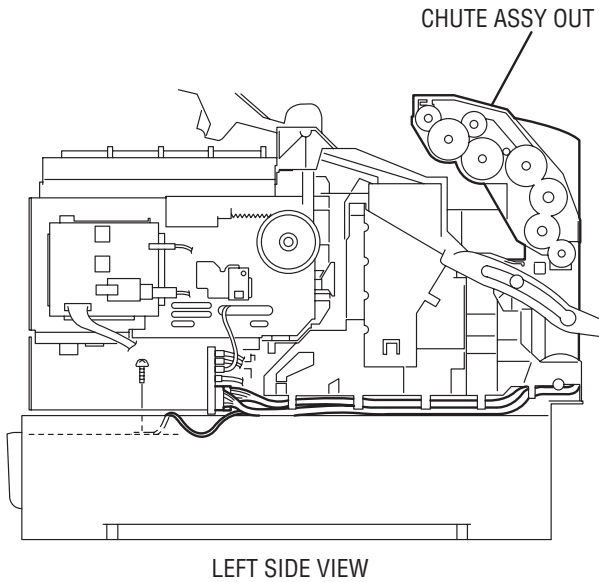

13. Free the wiring harness on the right side from the wire guides on the right side of the printer housing.

14. Remove the e-rings (item #1) from the right and left Shaft Pivots securing the bottom of the Chute Assembly Out to the printer.

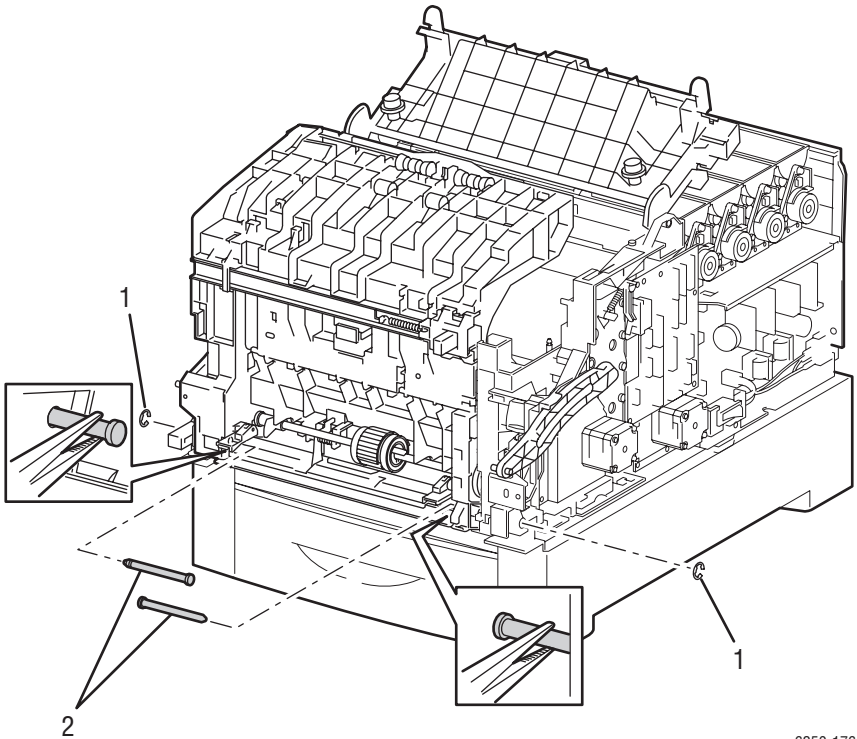

6250-176

15. Open Door B and press on the solenoid latch-plate on the left side to release the lower plate assembly. Ensure that the lower plate assembly raises up.

Caution

The plate assembly bottom may have sharp burrs, be careful when performing the following Steps.

16. Using needle nose pliers, remove the left and right Shaft Pivots (item #2), pulling them inward to remove.

Caution

Remove the Chute Assembly Out slowly and carefully ensuring that the wiring harnesses do not catch and sustain damage during removal.

17. Release the latch at Door B and pull the Chute Assembly Out forward to remove.

Output Tray Full Actuator (PL 6.1.5) and Full Stack Sensor (PL 6.1.4)

Removal - Actuator, Output Tray Full

1. Remove the Front Cover (page 8-6).
2. Deflect the shaft of the Actuator Output Tray Full (item #1) from the top portion of the Chute Assembly Out and remove the shaft from the left side.

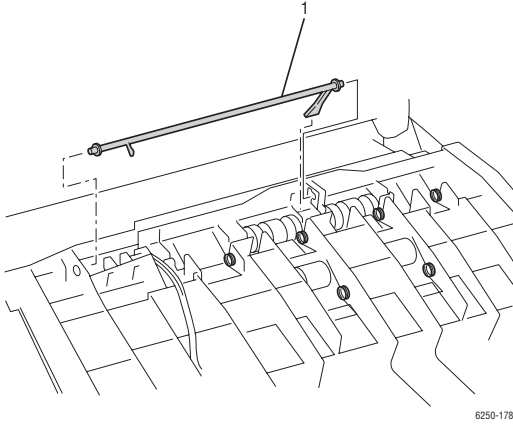

Removal - Full Stack Sensor

1. Remove the Actuator, Output Tray Full.
2. Disconnect P/J134 from the Full Stack Sensor (item #2).
3. Release the 3 tabs securing the Full Stack Sensor and remove.

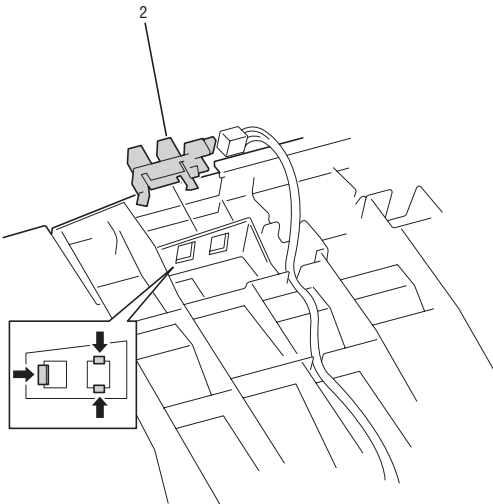

Duplex Actuator (PL 6.1.13) and Duplex Sensor (PL 6.1.4)

Removing the Duplex Actuator

1. Remove the Front Left Cover (page 8-16).
2. Release the 2 tabs securing the Actuator Cover, push in and remove the cover from inside the Chute Assembly Out.
3. Release the tab on the left side of the Duplex Actuator.
4. Push the actuator to the left and remove out the right side removing the actuator with the spring still on the shaft.

Note

Note the position of the actuator spring during removal to ensure proper reassembly.

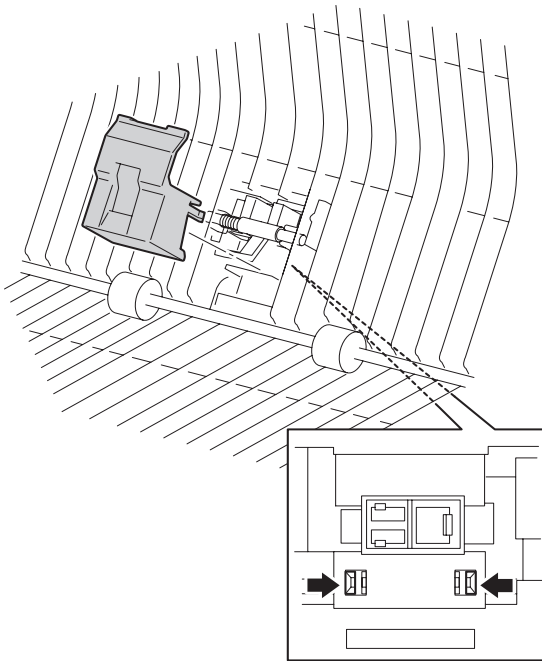

6250-182

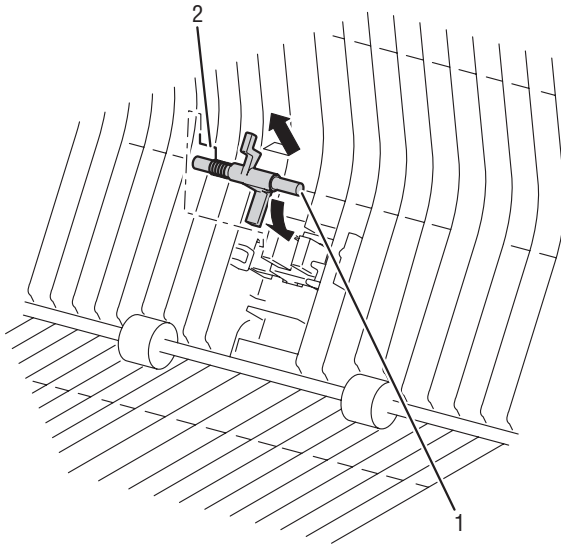

6250-183

Removing the Duplex Sensor

1. Remove the Duplex Actuator (item #1).
2. Release the 3 tabs securing the Duplex Sensor and remove the sensor.
3. Disconnect P/J133 from the Duplex Sensor.

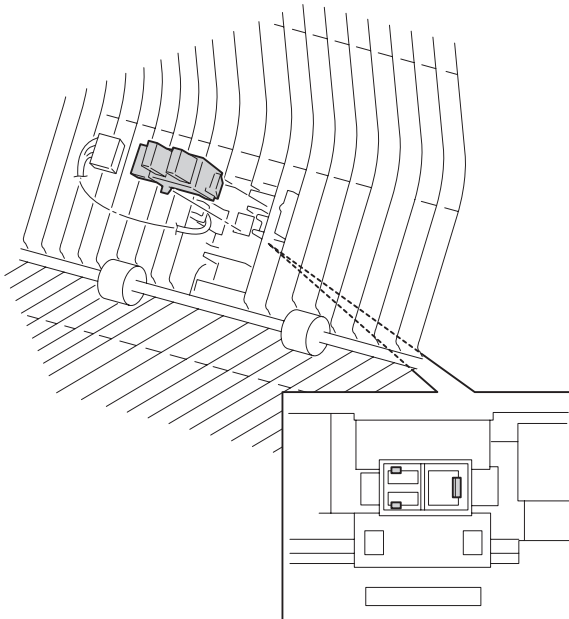

6250-185

Tray 1 Actuator (PL 6.1.37) and Tray 1 Sensor (PL 6.1.4)

Removal of the Actuator

1. Remove the Front Left Cover (page 8-16).
2. Push down on the Tray 1 metal plate and push the actuator in.
3. Slide the actuator (item #2) to the left and remove to the right.
4. Remove the spring (item #3) from the actuator.

Caution

Be careful not to lose or damage the spring. Note spring orientation for reassembly.

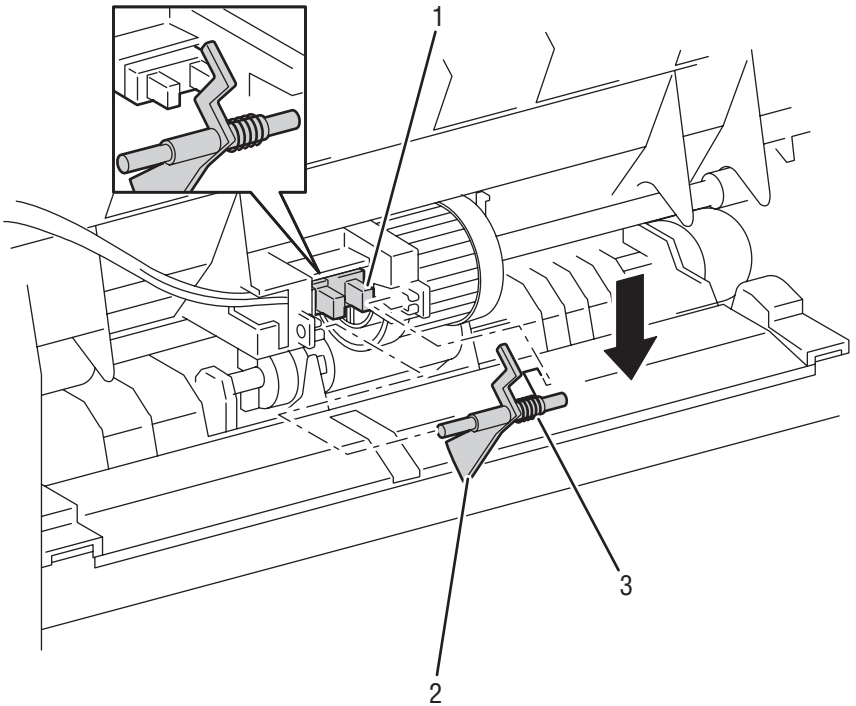

6250-187

Removal of the Sensor

1. Remove the Tray 1 Actuator.
2. Open Door B.
3. From the back of the sensor (item #1), release the 3 tabs securing the sensor and remove.
4. Disconnect P/J135 from the Tray 1 Sensor.

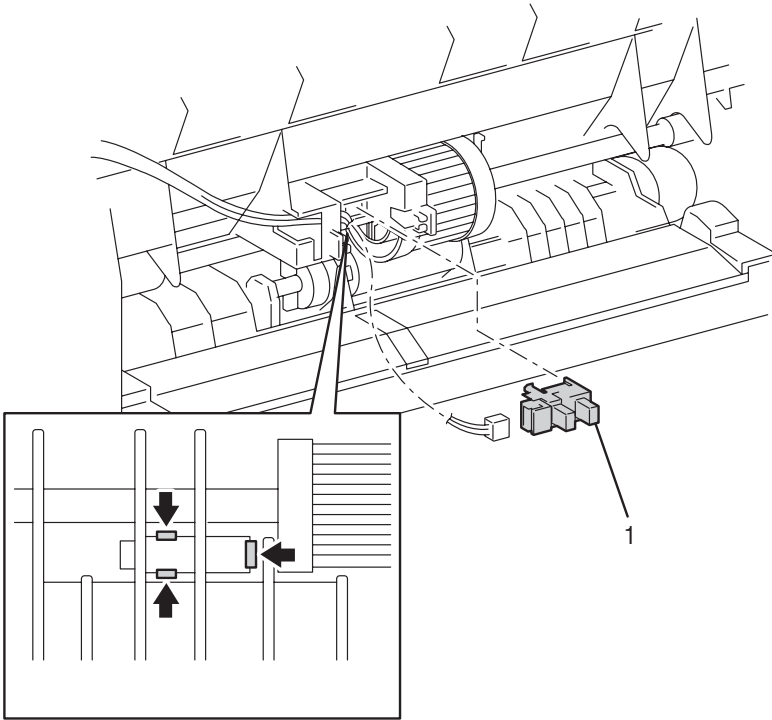

6250-188

Static Eliminator Assembly (PL 6.1.9)

1. Remove the Front Cover Assembly (page 8-6).
2. Remove 1 screw securing both the ground wire and the Static Eliminator Assembly (item #2) to the Chute Assembly Out (item #1).
3. Raise the left end up to clear the locator pin and remove the Static Eliminator Assembly by sliding it to the left.

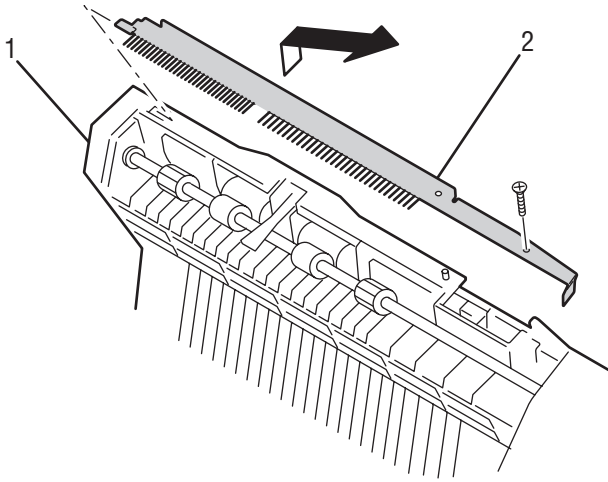

6250-180

Duplex Roller (PL 6.1.12)

1. Remove the Front Left Cover (page 8-16).
2. Release the tab securing Gear 30 (item #4), see "Duplex Motor Drive and Gear - Transmission Route" on page 2-31 and remove the gear.
3. Remove the bearing (item #5) securing the left end of the shaft.
4. Raise the left end of the roller and shift the right bearing (item #3) out then remove the Duplex Roller (item #2).

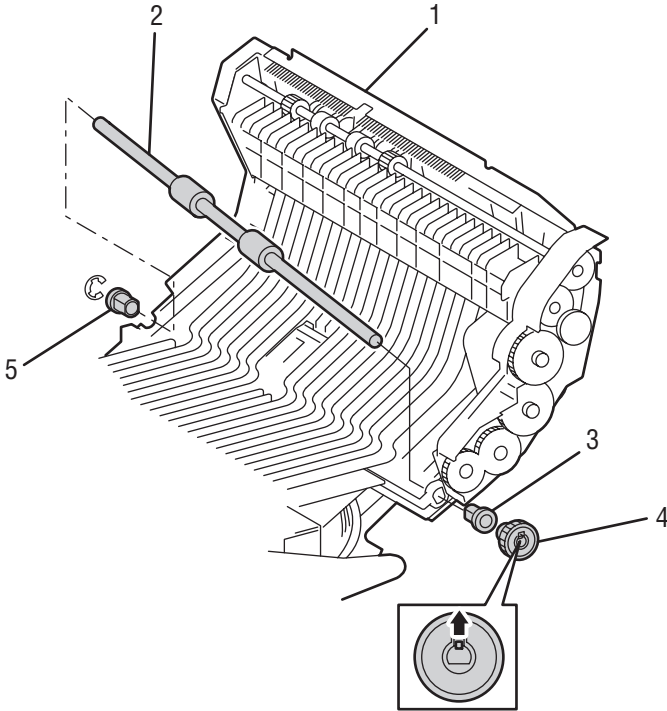

6250-181

Replacement Notes

Note

Ensure that black bearing is placed on gear end of shaft during reassembly.

Latch Plate (PL 6.1.17), Latch Out (PL 6.1.18), Latch Holder (PL 6.1.19), and Latch Spring Out (PL 6.1.20)

1. Remove the Front Right Cover (page 8-15).
2. Remove the Front Left Cover (page 8-16).
3. Remove the Spring Out (item #3) from the Chute Assembly Out.
4. Release the 2 tabs from the inside of the Chute Assembly Out.
5. Slide the Holder Latch (item #2) to the right and remove.
6. Remove the Latch Out (item #1) from the Holder.

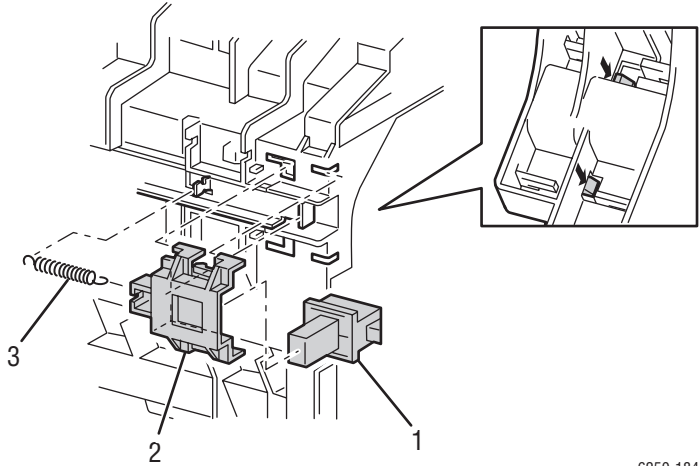

6250-184

Tray 1 Paper Pick Assembly (PL 6.1.27) (Roll Feed)

1. Remove the Front Left Cover (page 8-16).
2. Release the tab securing the roll core (item #1) to the shaft and slide right.
3. Push down on the Tray 1 metal plate (item #2) and feed roller.
4. Slide the Paper Pick Roller (item #3) to the right and pull out the front to remove.

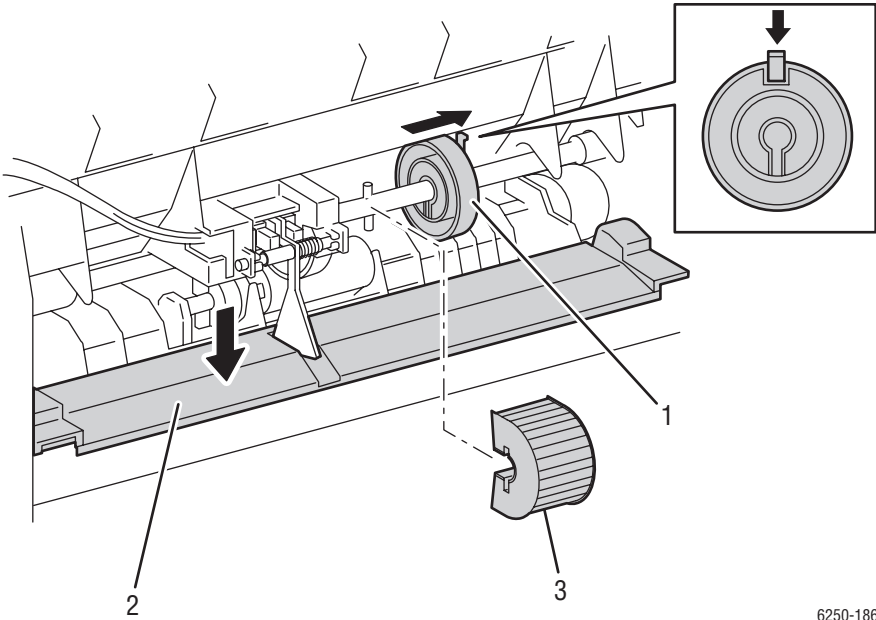

6250-186

Tray 1 Feed Solenoid (PL 6.1.40)

1. Remove the Chute Assembly Out (page 8-47).
2. Unhook the N/F Tray 1 spring (item #1) from the Solenoid Stopper (item #2).
3. Disconnect P/J132 (orange wires) from the Solenoid and shift the wires out of the cable guides on the Chute Assembly Out.
4. Remove 1 screw securing the Feed Solenoid (item #3) to the Chute Assembly Out and remove.

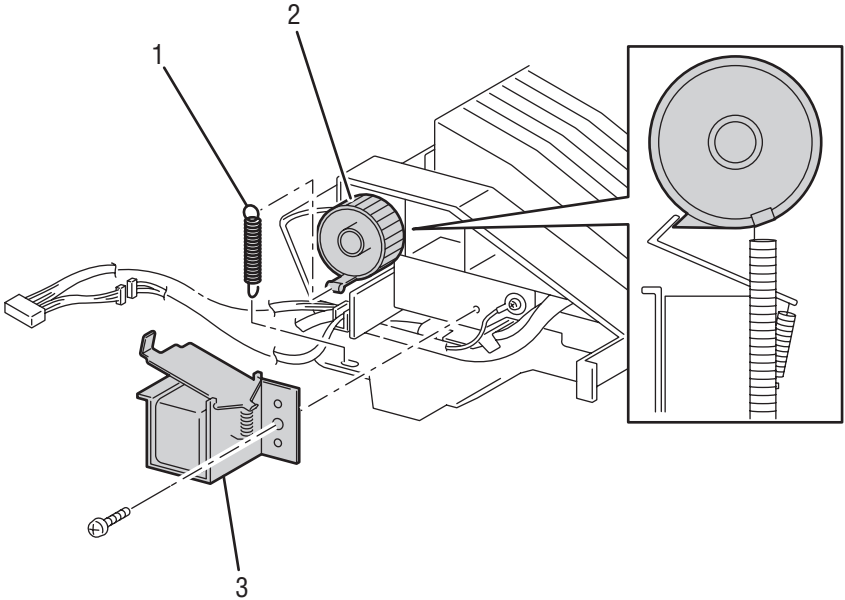

6250-189

Reassembly Notes

Note

Make sure the solenoid seats properly on the aligning pins. The pins are plastic.

Tray 1 Shaft (PL 6.1.28)

1. Remove the Chute Assembly Out (page 8-47).
2. Remove the spring from the Solenoid Stopper (item #2).
3. Release the tab securing the Solenoid Stopper to the shaft and remove.
4. Release the tab on the Tray 1 Gear (item #5) and remove the gear.

Note

Note the orientation of the springs for reassembly. A long eye hook attaches to the shaft.

5. Remove the 2 springs (item #1 and #4) from the left and right sides of the shaft.

Note

In the following Step, do not lose the pins when moving the CAMs.

6. Release the tab securing each CAM in position and slide the CAMs (item #3) in.
7. Slide the shaft to the right and remove.

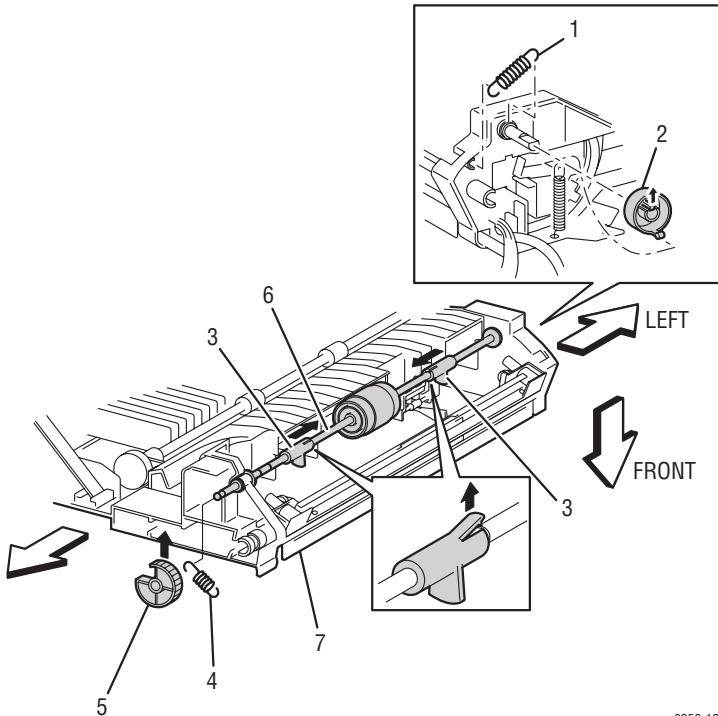

6250-191

Tray 1 Bottom Plate (PL 6.1.42)

1. Remove the Chute Out Assembly (page 8-47).
2. Remove the 2 screws securing the plate (item #1) to the Chute Out Assembly.
3. Remove the left and right springs from the Tray 1 Shaft.

Note

In the following Steps, shift the actuator out of the hole in the Plate bottom when removing the Plate.

4. Remove the Tray 1 Bottom Plate Assembly (item #2).

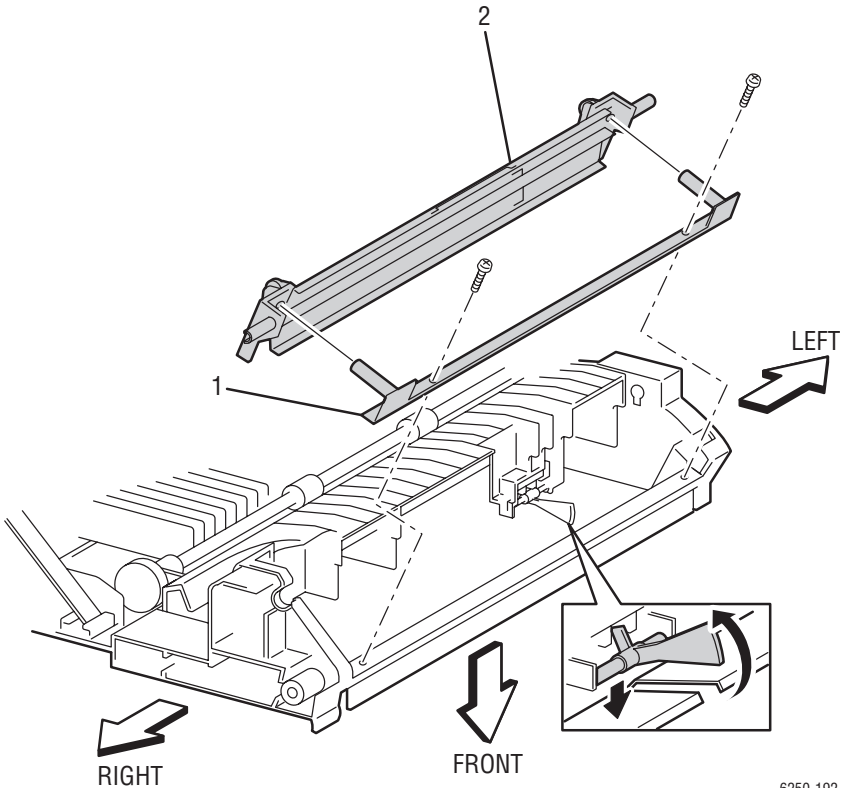

6250-192

Reassembly Notes

Note

Ensure that Tray 1 Bottom Plate is properly seated on locator pins before tightening the retaining screws, the locator pins are plastic and can be damaged.

Chute Assembly Exit

Chute Assembly Exit (PL 7.1.1)

1. Remove the Front Cover (page 8-6).
2. Remove the Front Left Cover (page 8-16).
3. Disconnect P/J131 and shift the harness to the side of the Chute Assembly Out.
4. Remove the 2 screws, the upper screw is attached to the static discharge harness, securing the Chute Assembly Exit to the Chute Assembly Out.

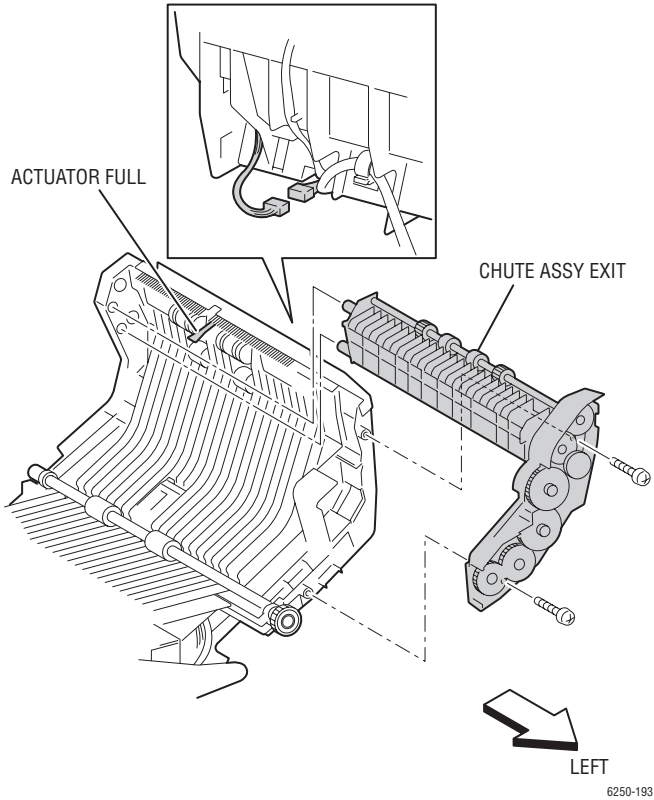

6250-193

Mid Roller (PL 7.1.5)

1. Remove the Chute Assembly Exit (page 8-62)
2. Release the tab securing the Gear Roll (item #1) and remove the Gear.
3. Remove the bearing from the left side of the shaft.
4. Remove the e-ring and bearing (item #2) securing the right side of the shaft.
5. Raise the right side of the shaft and pull out the Mid Roll (item #3).

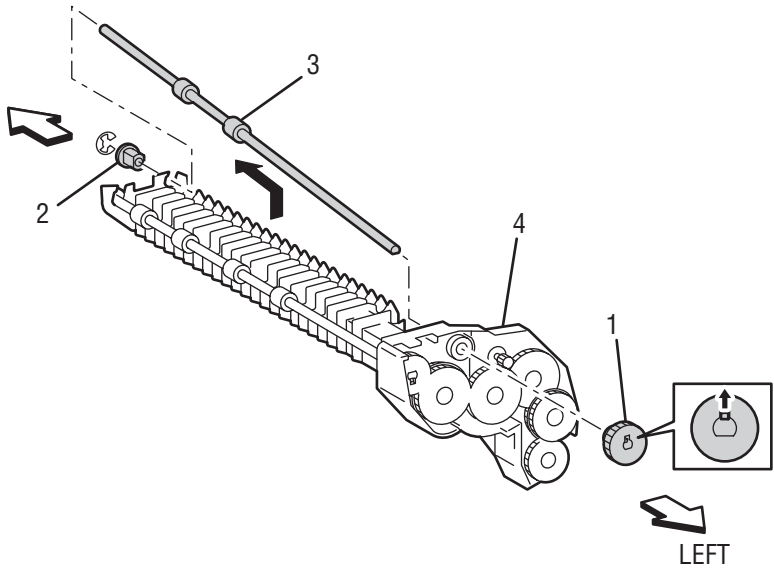

Duplex Motor Assembly (PL 7.1.8)

1. Remove the Chute Assembly Exit (item #1) (page 8-62).
2. Rotate Gear 48 (item #2) to access 1 screw securing the Duplex Motor Assembly (item #6) to the Chute Assembly Exit, then remove the other screw.
3. Remove the Duplex Motor Assembly from the Chute Assembly Exit.

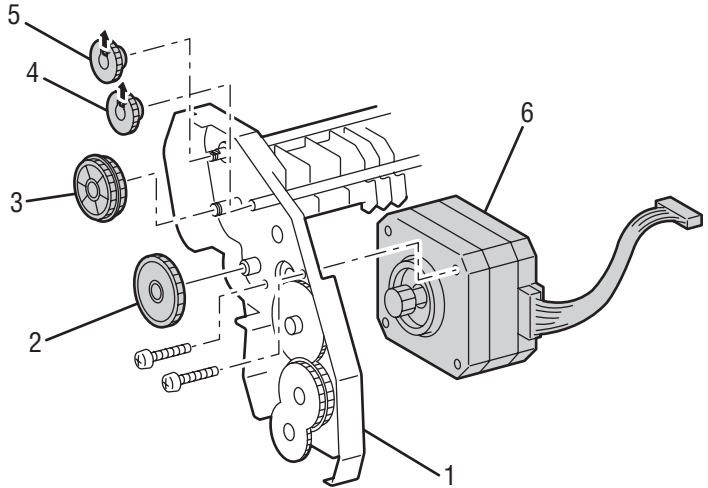

6250-196

- | | |
|------------------------|--------------------------|
| 1. Chute Assembly Exit | 4. Gear Mid Roller |
| 2. Gear 48 | 5. Gear Exit roller |
| 3. Gear 40/42 | 6. Motor Assembly Duplex |

Exit Actuator (Fuser) (PL 8.1.7)

1. Open Door B and remove the Fuser Assembly.
2. Lift the tab that secures the bearing to the left side of the Fuser Exit Roller shaft and remove the bearing.
3. Move the exit roller slightly out of the way.
4. From the outside of the fuser cover, push the Exit Actuator out of the retaining clips being careful not to drop the spring into the fuser.
5. Remove the Actuator Spring.

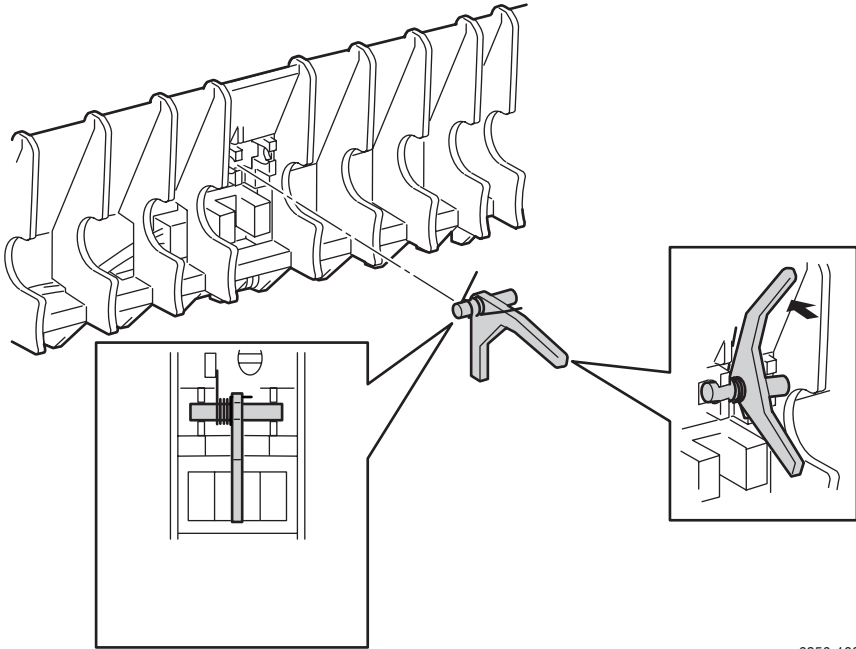

6250-198

Reassembly Notes

Note

Ensure that the spring is positioned as shown in the figure.

Strap (PL 8.1.13)

1. Open Door B.

Caution

Support Door B when removing the strap to prevent damage to the unit, and continue to provide support or latch the door when the strap is removed.

2. Turn the top of the strap 90 degrees and remove top end of strap.
3. Push down on the strap retainer tab and slide the bottom end of the strap out of the slot.

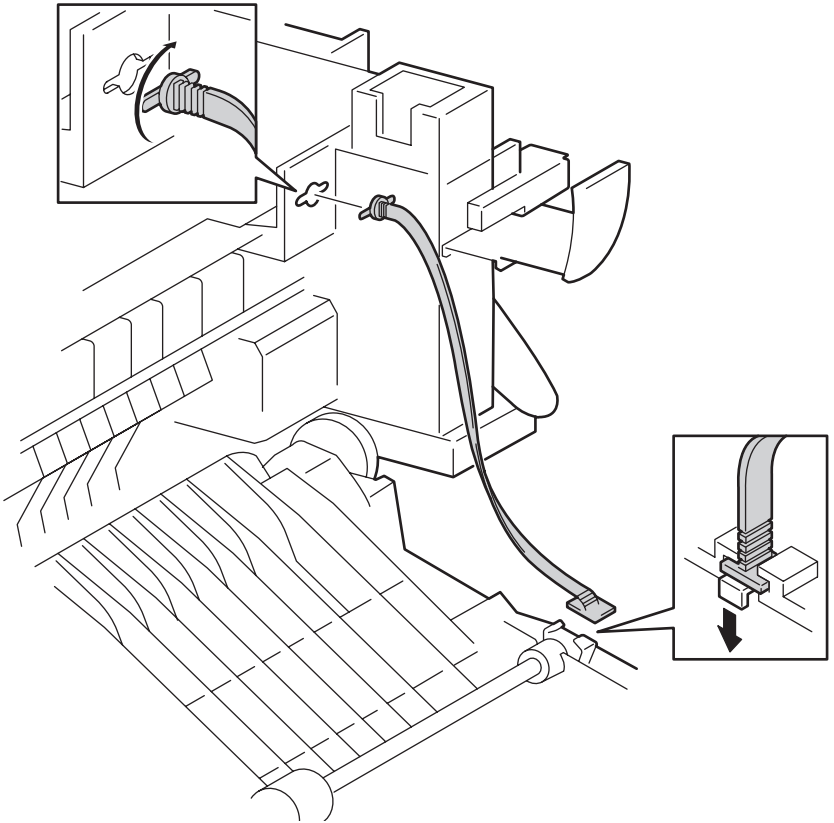

Xerographics

Laser Unit (PL 9.1.1)

1. Remove the Toner Cartridge Holder Unit Assembly (page 8-77).
2. Remove the Rear Fan (page 8-102).
3. Disconnect P/J151 from the Laser Unit.
4. Unhook the springs from the left and right ends of the shaft.

Caution

Handle the Laser Unit carefully; avoid bumping or jarring the unit.

5. Remove 3 screws securing the Laser Unit to the printer and slide the unit back to remove the assembly.

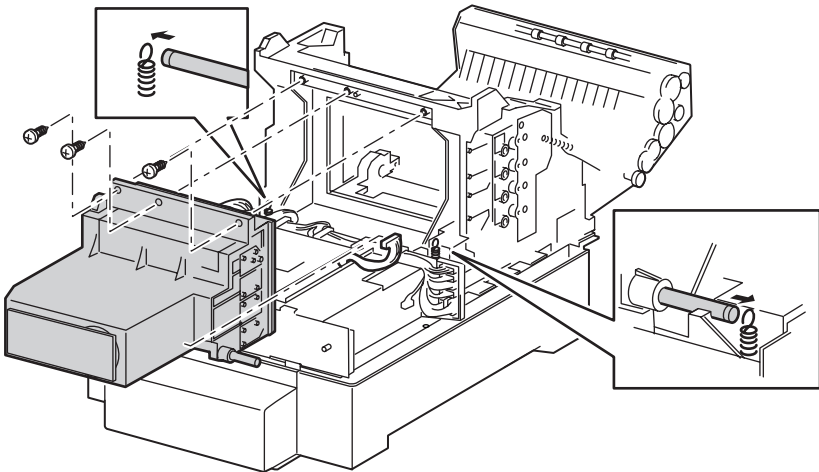

6250-203

Replacement Notes

1. Align the Laser Unit with the printer (locator stud in the oval hole on the unit).
2. Replace the hook on each Laser Spring in the notch at each end of the shaft.
3. Replace the 3 screws that secure the Laser Unit to the printer.
4. Reconnect P/J151.

Note

Perform the Color Registration procedure after replacing the Laser Unit.

Housing Assembly Bias (PL 9.1.4)

Note

The Imaging Unit must be removed to prevent loss of the biasing buttons.

1. Remove the Imaging Unit and protect it from exposure to light.
2. Remove the Left Side Cover (page 8-11).
3. Disconnect all the wires routed along the left side (including the ground wire) and remove them from the wire guides.
4. Remove the 5 screws securing the Housing Assembly Bias.
5. Remove the Housing Assembly Bias by pulling it straight out to avoid damaging the spring contacts.

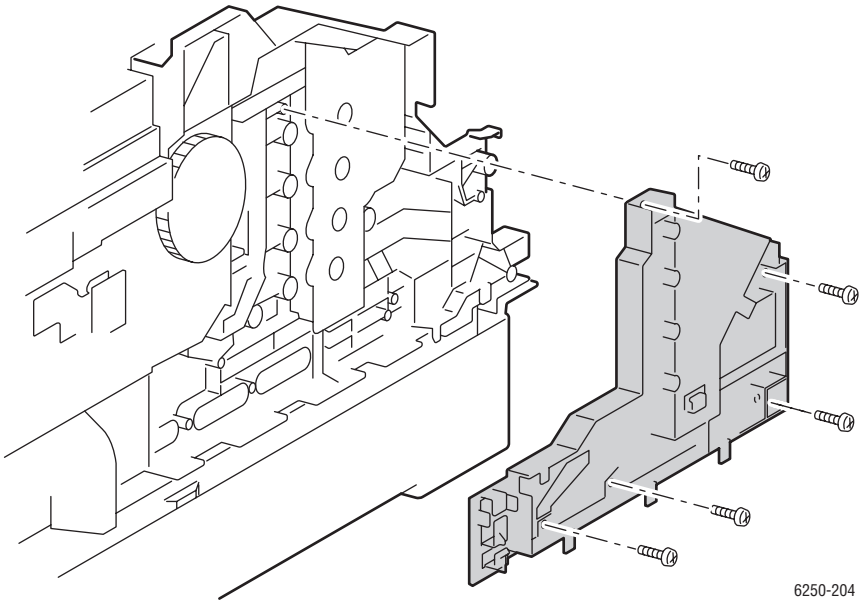

6250-204

Caution

The biasing buttons fall out easily when touched from inside the printer, see the following drawing for location. Avoid touching the biasing buttons while the Housing Assembly Bias is removed from the printer.

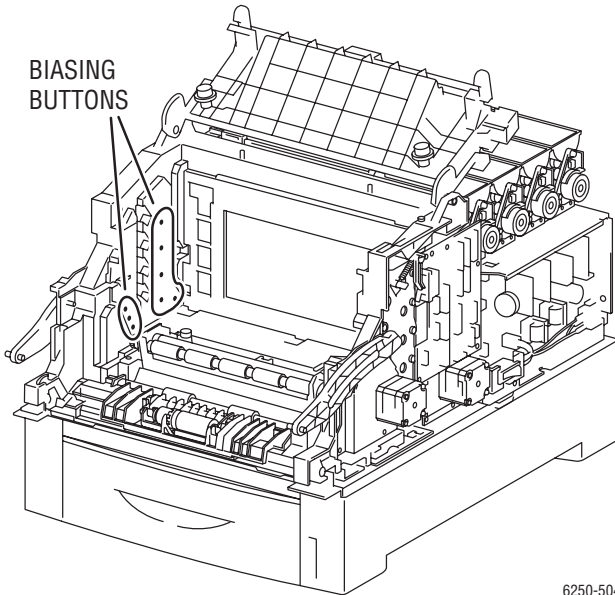

6250-504

Replacement Notes

Caution

To avoid equipment damage, move all wiring harnesses out of the way when replacing. Ensure that all 8 biasing buttons (PL 9.1.5) are in place. Verify the proper alignment of the biasing springs.

Chute Assembly Registration (PL 9.1.6) and Housing Assembly Electric (PL 9.1.11)

1. Remove the Imaging Unit and protect it from exposure to light.
2. Release the 2 tabs securing the Housing Assembly Electric cover to the printer and lift straight up to remove.
3. Disconnect P/J18 (blue) from the Registration Chute Assembly to the Engine Control Board.
4. Disconnect P/J32 (blue) from the OHP Sensor to the Engine Control Board.

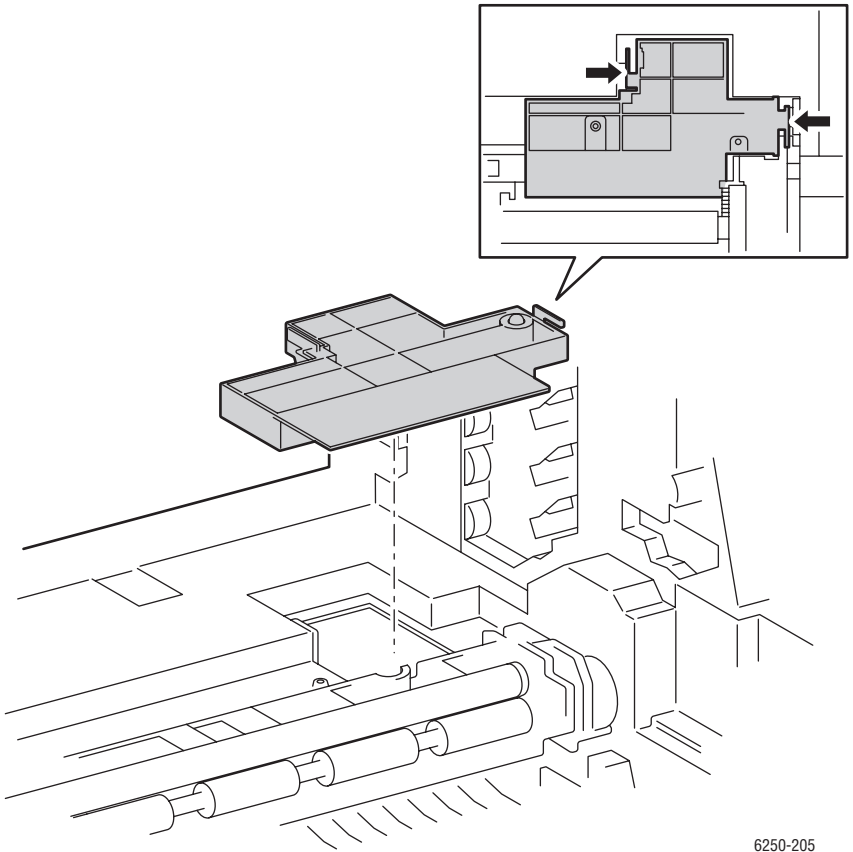

6250-205

5. Remove the 4 screws securing the Registration Chute Assembly.

6. Raise the left side of the Registration Chute Assembly and pull towards the left side of the printer to remove.

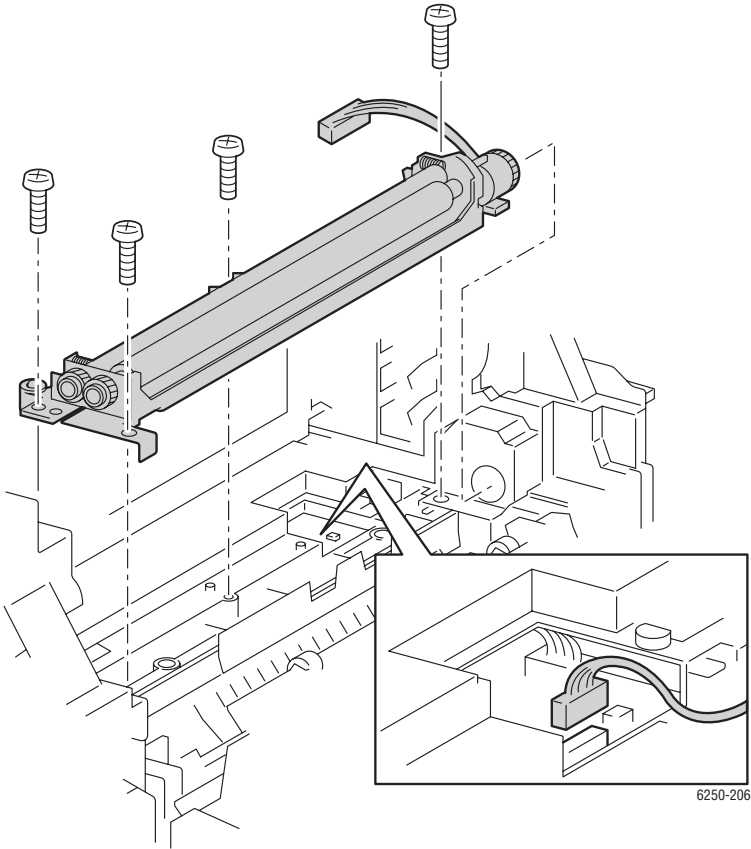

Replacement Notes

Note

Ensure the mylar strip (item #1) is not bent or pinched but seated properly in the middle cavity of the Registration Chute when reassembling.

When reinstalling the Registration Chute, ensure that the spring on the left rear corner does not get damaged and that it makes contact with the electrical connection on the Engine Control Board.

Registration Sensor Actuator (PL 9.1.9) and Registration Sensor (PL 9.1.8)

Removal of Actuator

1. Remove the Chute Assembly Registration (page 8-71).
2. Shift the actuator (item #1) to the left, lift up on the right side and remove.
3. Remove the actuator spring (item #2) from the Actuator.

Note

Make note of the orientation of the spring for reassembly.

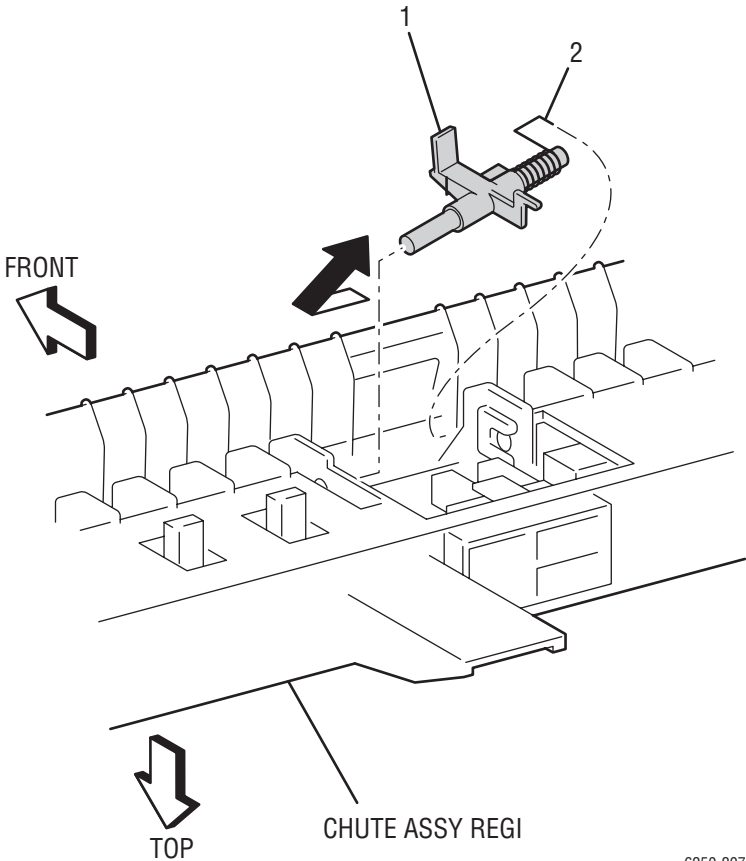

6250-207

Removal of Sensor

1. Remove the Registration Actuator.
2. Disconnect P/J181.
3. Release the 3 tabs securing the Sensor to the Chute Assembly Registration and remove the sensor.

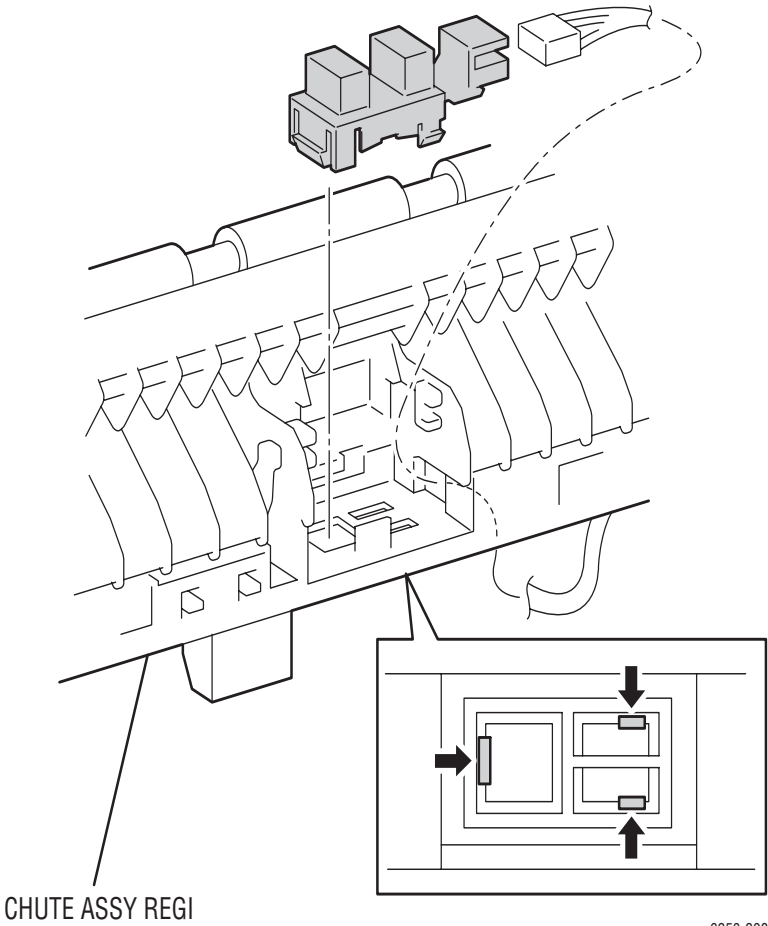

OHP Sensor and Harness (Kit) (PL 9.1.12)

1. Remove the Chute Assembly Registration (page 8-71).
2. Remove the 2 e-rings securing the 2 Gears (items #4 & #5) and remove the gears.

Note

When removing the Springs use caution, they spring off the shaft easily.

3. Remove both springs (item #1 & #6).
4. Pull out the bearing on the left side of the shaft (item #3).

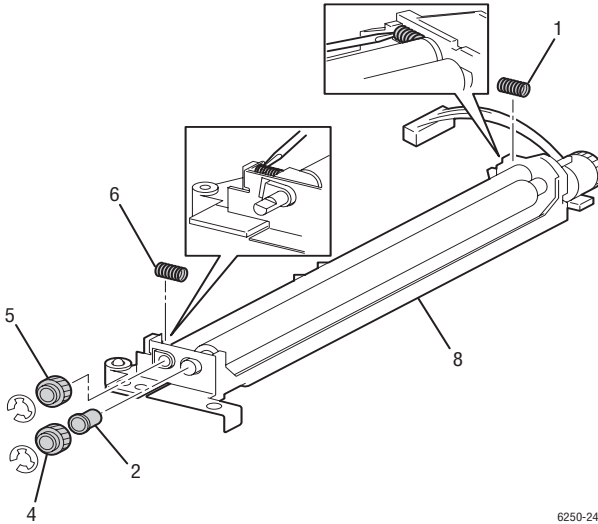

5. Remove 1 screw from the left side of the Chute Assembly (item #8) securing the Bracket Assembly (item #7).
6. Pull off the black plastic bearing (item #2) securing the left side of the metal registration roller (item #9) .

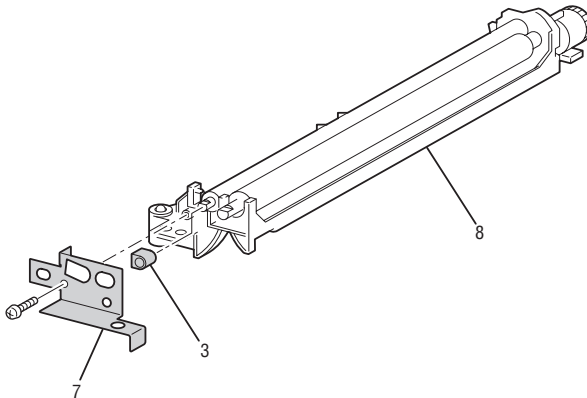

7. Raise the left end of the shaft and remove with the right white plastic bearing attached.

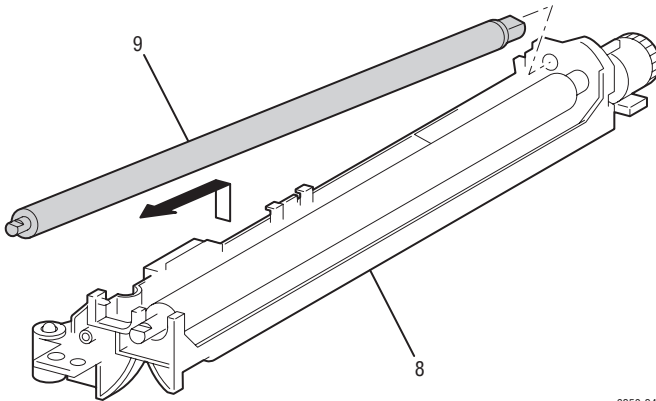

6250-249

8. Pull back on the tabs on the bottom of the Chute Assembly to remove the OHP Sensor Cover (item #10).
9. Lift the retaining tab and remove the OHP Sensor from the cover.
10. Disconnect P/J321 from the sensor.

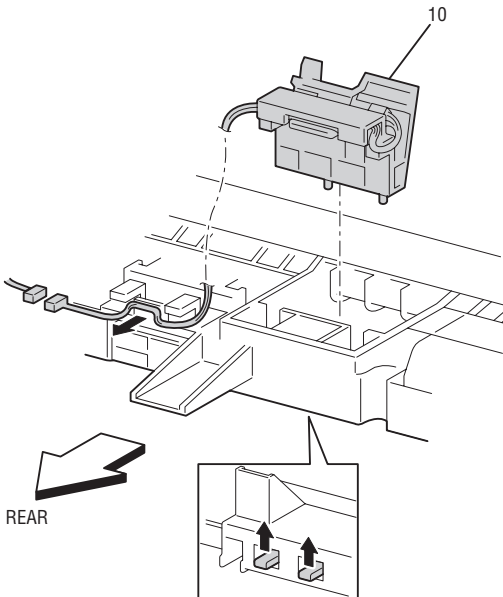

6250-250

Replacement Notes:

Note

When reassembling, the white gear (item #5) goes on the metal roller, and the black gear (item #4) goes on the rubber roller. Install the springs last.

Toner Cartridge Holder Assemblies

Toner Cartridge Holder Unit Assembly (PL 10.1)

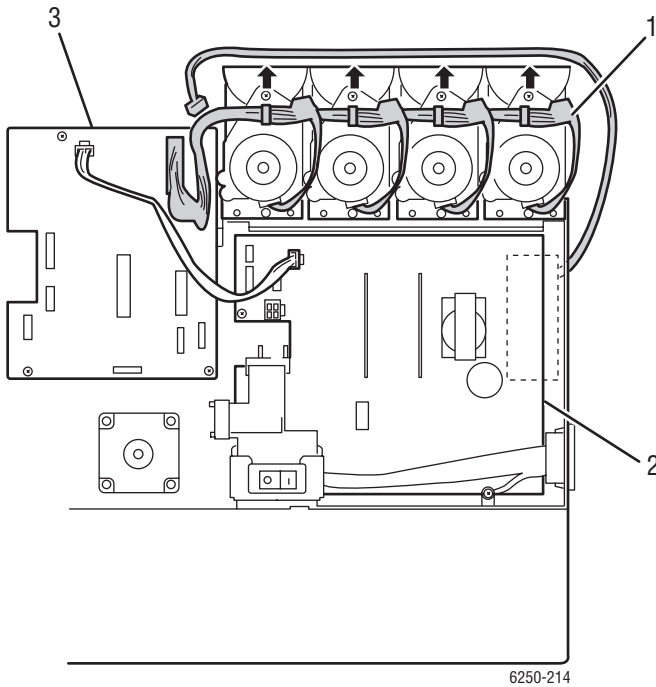

Note

Use only a Type II Toner Vacuum to remove toner deposits before removing the Toner Cartridge Holder Unit (item #1). When removing toner deposits, be careful not to get toner into the sensors.

1. Remove the Imaging Unit and protect it from exposure to light.
2. Remove the Top Main Cover (page 8-9).
3. Remove the Right and Left Side Covers (page 8-11).
4. Remove the Rear Cover (page 8-12).

Caution

Reinstall the toner cartridges to seal the toner system and prevent spillage.

5. Disconnect P/J166 from the Low-Voltage Power Supply (item #2) to the rear fan and remove the wiring harness from the wire guides on the right side of the printer. Be very careful not to break the tabs on the wire guides.

6. Disconnect P/J51 from the Motor Driver Board (item #3).
7. Disconnect P/J144 (yellow top) and P/J145 (gray bottom) from the EEPROM Board (item #4).
8. Disconnect the third connector down (P/J71) from the connector block on the left side of the printer.
9. Disconnect P/J5020, P/J5030, and P/J5011 from the Sub-High-Voltage Power Supply Board (item #5).
10. Release P/J5011 from the clamp.

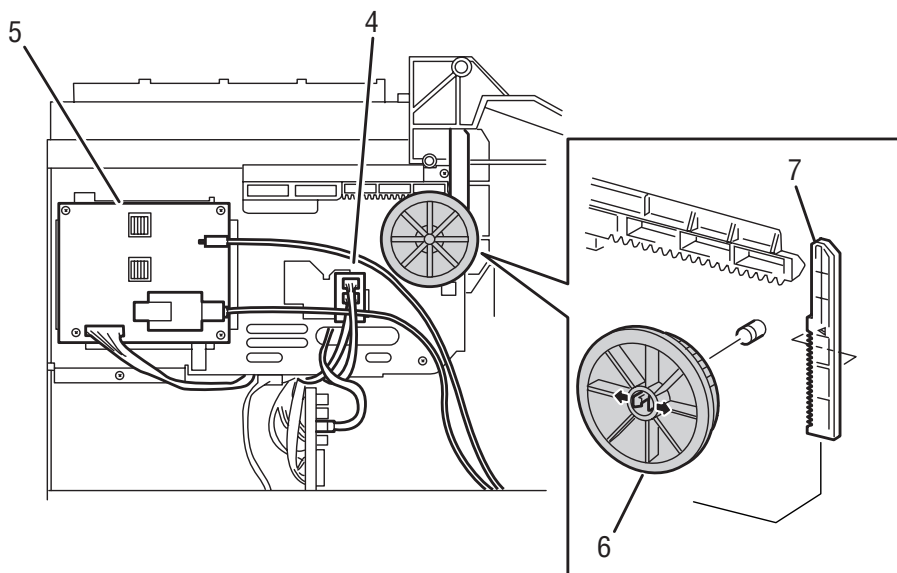

6250-215

11. Open Door C to release the pressure on the rack and release the 2 tabs securing the Gear Slide (item #6) and remove the slide and Rack V (item #7) from the printer.
12. Reach under the Toner Cartridge Holder Unit from the rear and disconnect P/J3411 from the CRUM Reader Board.

13. Remove the 8 screws securing the Toner Cartridge Holder Unit and carefully remove the unit to the left. Flex the Dispenser Plate slightly during removal to clear the locator pin and the clearance notch at the front.

Note

The 4 screws on the right side of the printer are below the toner motors.

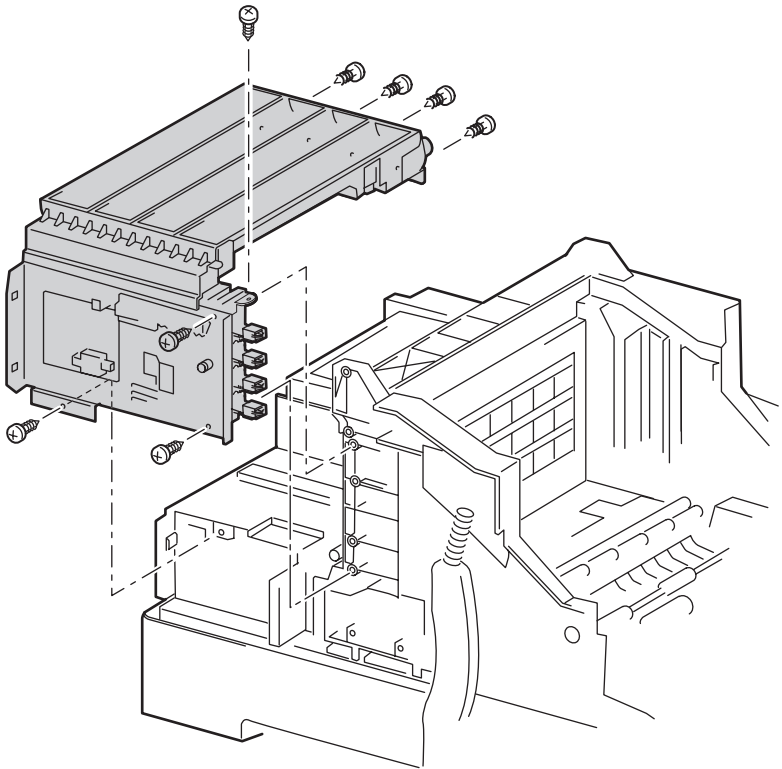

6250-216

Replacement Notes

1. Replace in reverse order. Reconnect the ground wire using the front lower screw on the left side.

Note

An “Install or Reseat Imaging Unit” error can occur if the Gear and Rack V are not properly aligned. With Door C open, push the Rack V as far up as it can go, then replace the gear.

Toner Cartridge Holder Assembly

(Y) (PL 10.1.1)

(M) (PL 10.1.2)

(C) (PL 10.1.3)

(K) (PL 10.1.4)

1. Remove the Holder Toner Cartridge Assembly Unit (page 8-77).

Note

Reinstall the toner cartridges to prevent spillage. The holders need to be removed in Y, M, C, K order. There are small locking tabs between the holders on each end that lock them together. Reinstall the cartridges in the opposite order

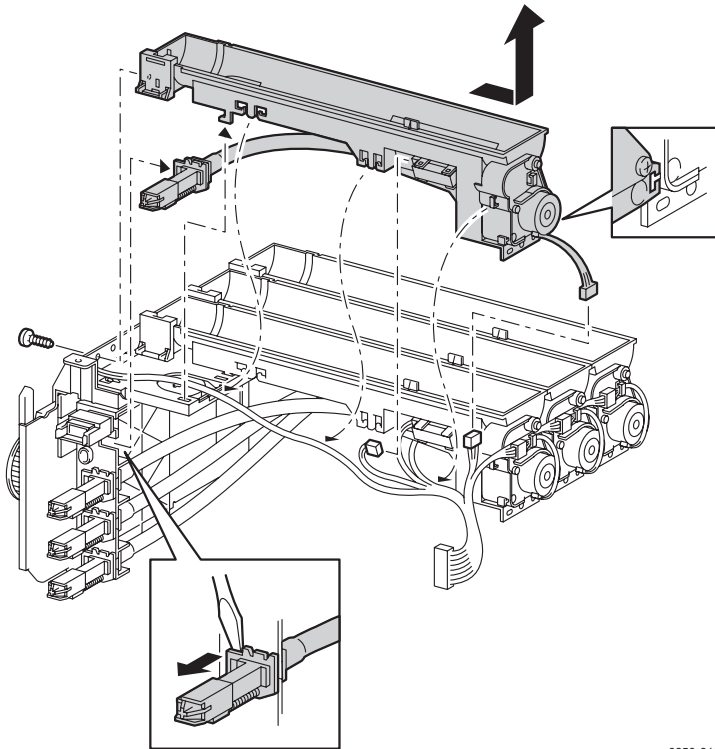

6250-210

Note

You will need to disconnect all the connectors before removing the toner holder in the next Steps.

- 2.** Disconnect the following Plug/Jacks from each dispenser:
 - Y - P/J511 and P/J701
 - M - P/J512 and P/J702
 - C - P/J513 and P/J703
 - K - P/J514 and P/J704
- 3.** Remove the harness from the cable guides on the side of the yellow Toner Cartridge Holder Assembly.
- 4.** Remove the harness from the cable guide on the end of each Toner Cartridge Holder Assembly above the Toner Motor.
- 5.** Remove the screw securing each Toner Cartridge Holder Assembly (Y, M, C, K) to the Plate Dispenser and slide the Toner Cartridge Holder to the right to remove.
- 6.** In the Holder Toner Assembly Unit, release the tab securing the auger tube from the Plate Dispenser (PL 10.1.13) with a small screwdriver and remove by sliding to the right.

Toner Present Switch Bracket and Actuator (PL 10.1.6 and 10.1.22)

1. Remove the Imaging Unit and protect it from exposure to light.
2. Remove the Top Main Cover, see page 8-9.
3. Remove the Left and Right Side Covers, see page 8-11.
4. Remove the Rear Cover, see page 8-12.
5. Remove the Cartridge Holder screws on each side working from the Yellow cartridge back to the cartridge that is to be removed.

Note

When removing the Black cartridge, remove only the screws for that cartridge.

6. Disconnect P/J 51 from the Motor Driver Board.
7. Starting at the Yellow cartridge, disconnect the motor connector and remove wires from the cable retainers.
8. Beginning with the Yellow, slide the toner holder slightly to the right just far enough to clear the left alignment pin, then lift first the right end and then the left end of the holder.

Note

It may be necessary to disconnect the Toner Low Sensor connectors (P/J 701 Y, P/J 702 M, P/J 703 C, and P/J 704 K) to move the holder out of the way.

9. Move the holder out of the way and proceed with the next one until the desired cartridge is reached.
10. Remove the Toner Cartridge.

Note

Rotate the Toner Holder Assembly with the switch facing up before removing the switch to prevent toner spills.

11. Carefully pry the tabs securing the Toner Present Switch Assembly with a small screwdriver and remove the switch.

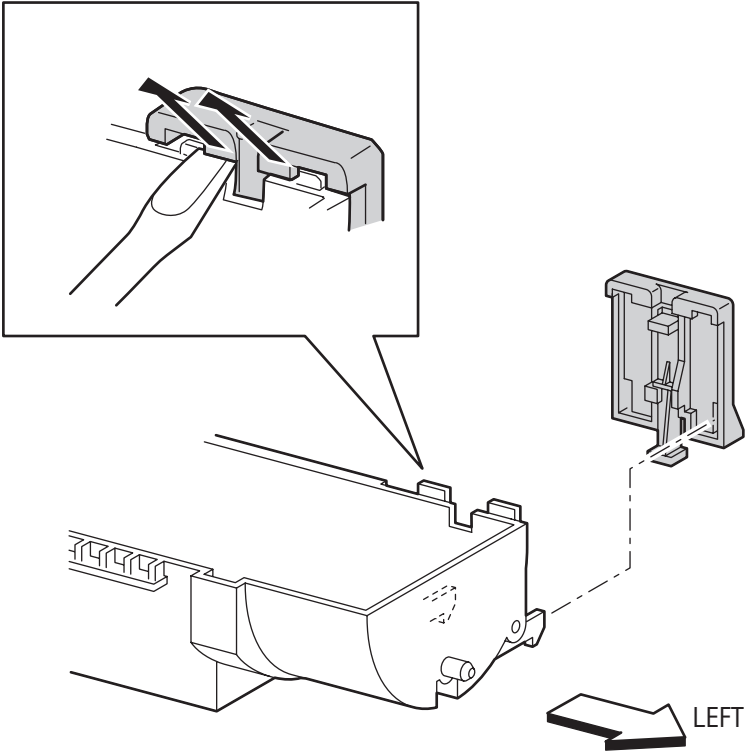

6250-217

Toner Low Sensor (PL 10.1.5)

1. Remove the Toner Cartridge Holder Assembly of the relevant color following the procedure given for the "Toner Present Switch Bracket and Actuator (PL 10.1.6 and 10.1.22)" on page 8-82.

Note

To prevent toner spills, leave the Toner Cartridge locked in place and rotate the Toner Holder Assembly so the sensor is facing up before removing the sensor.

2. Push open the 4 tabs securing the Low Toner Sensor to the holder and remove the sensor.

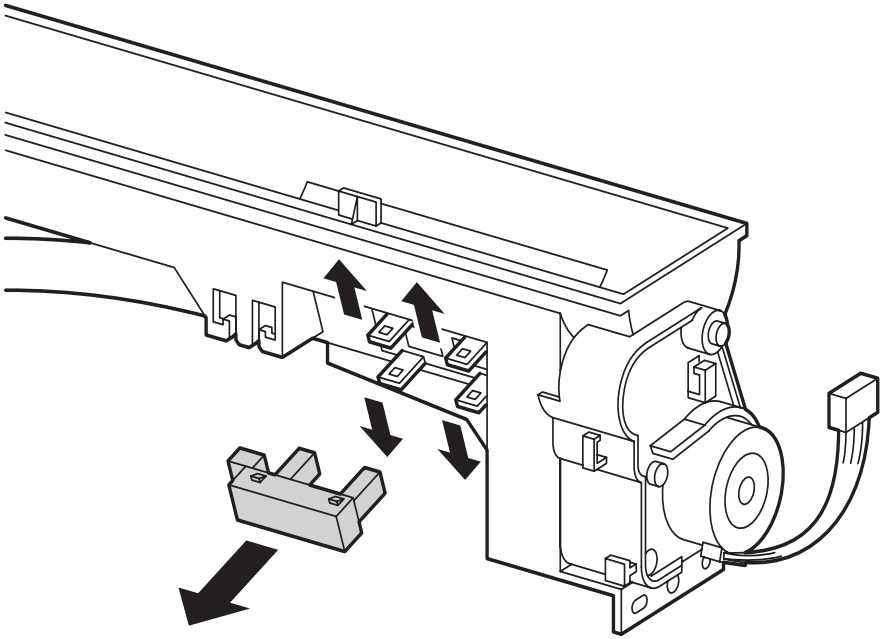

6250-218

CRUM Reader Box Assembly (PL 10.1.21)

1. Remove the Top Main Cover (page 8-9).
2. Remove the Right and Left Side Covers (page 8-11).
3. Remove the Rear Cover (page 8-12).
4. Disconnect P/J 342 and P/J 3411 from the CRUM Reader Box Assembly and remove the wires from the cable holders.
5. Remove the 7 screws securing the CRUM Reader Box Assembly (item #1) to the printer; 4 underneath the cartridge holders, 2 connecting the bottom of the CRUM to the Dispenser Plate (item #2), and 1 inserted vertically through the front of the CRUM.
6. Push in slightly on the Dispenser Plate to disengage the locator pins, lift the CRUM slightly and slide it out to the left rear.

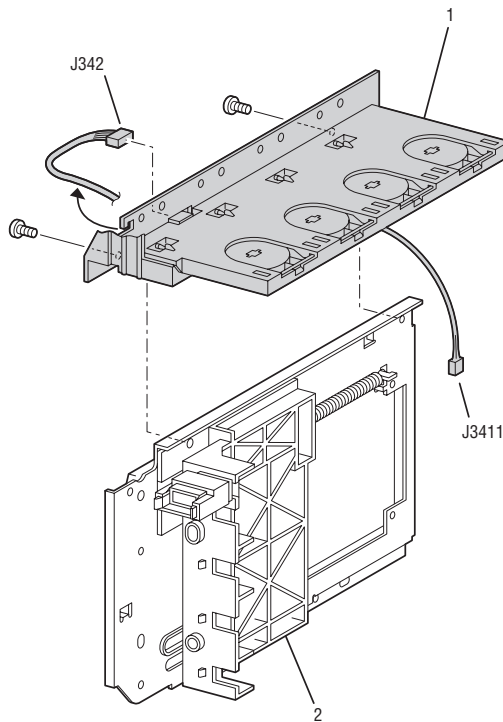

6350-492

Replacement Notes

Note

Support the CRUM Reader from underneath and slide it into position. Position each cartridge holder, working from Yellow to Black and slide the CRUM to the right to lock the cartridge holders in place.

EEPROM Board (PL 10.1.14)

1. Remove the Left Side Cover (page 8-11).

Caution

The yellow and gray harnesses to the EEPROM Board contain the same number of pins, but are NOT interchangeable. Make sure P/J144 (yellow) is connected to the top connector and P/J145 (gray) is connected to the bottom connector.

2. Disconnect P/J144 and P/J145 from the EEPROM Board on the left side of the printer.
3. Remove 1 screw securing the EEPROM Board and remove the board.

Note

When a new EEPROM Board is installed in the printer, the CRUM data written to the EEPROM makes it unique to that printer. The EEPROM board cannot be re-used in another printer.

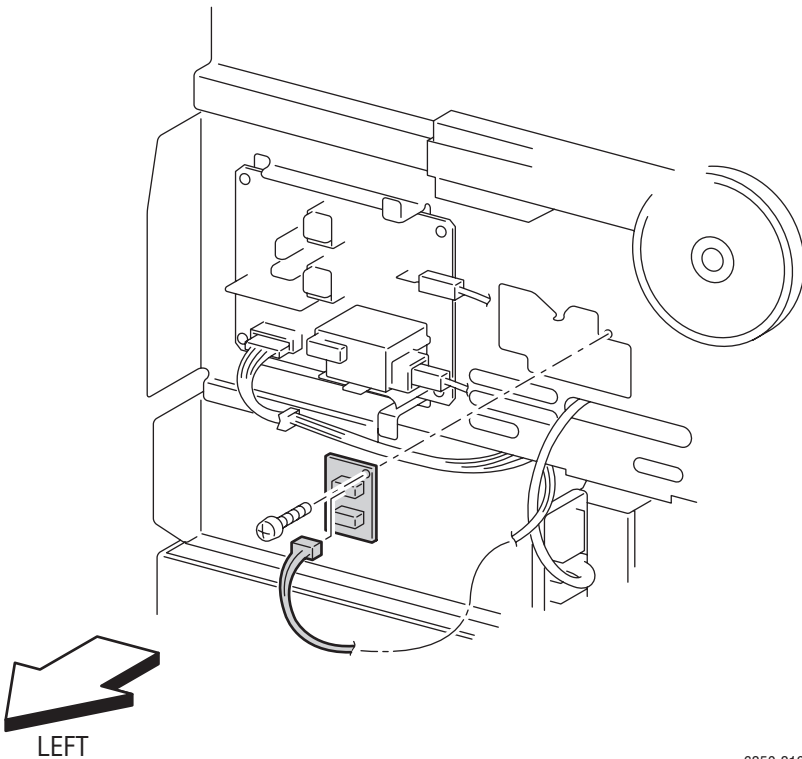

6250-219

Sub-High Voltage Power Supply Board (PL 10.1.15)

1. Remove the Left Side Cover (page 8-11).
2. Disconnect P/J5011, P/J5030, and P/J5020 from the Sub-High Voltage Power Supply Board.
3. Remove the 4 screws securing the board to the printer and remove the Sub-High Voltage Power Supply Board.

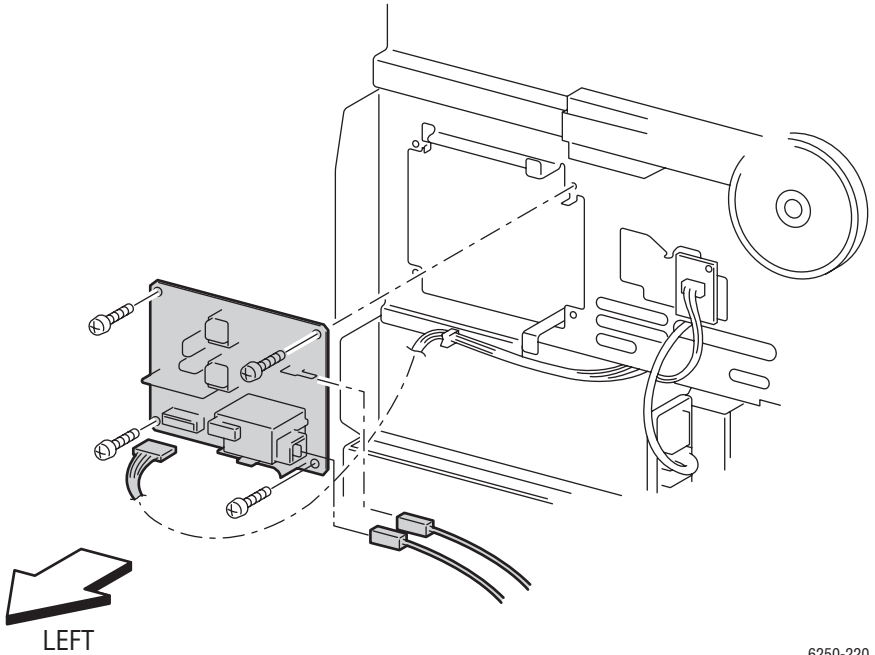

6250-220

Frame and Drive Assemblies

Left Lever Plate (PL 11.1.1), Lever Bracket (PL 11.1.2), Lever Link (PL 11.1.3), Lever Drum (PL 11.1.4), and Lever Spring (PL 11.1.5)

1. Remove the Left Cover (page 8-11).
2. Remove the Top Imaging Unit Cover Door C (page 8-10).
3. Unhook the Left Link Spring (PL1.1.22).

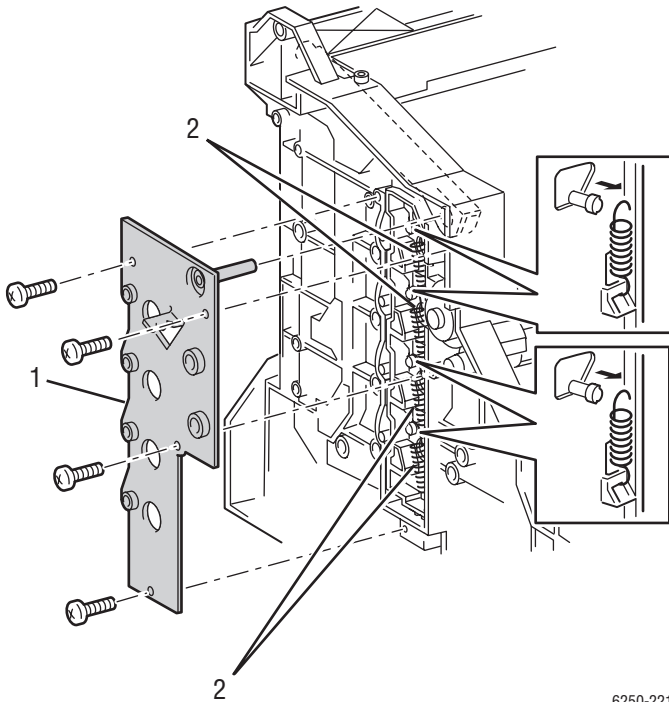

6250-221

4. Remove the Housing Assembly Bias (page 8-69).
5. Remove the 4 screws securing the Left Plate Assembly (item #1).
6. Press on the aligning post in the upper right corner of the plate from inside the cavity of the printer to remove the Plate Assembly.

7. Unhook the top end of each of the four lever springs (item #2) from the arm of the drum lever where it extends through the lever link.

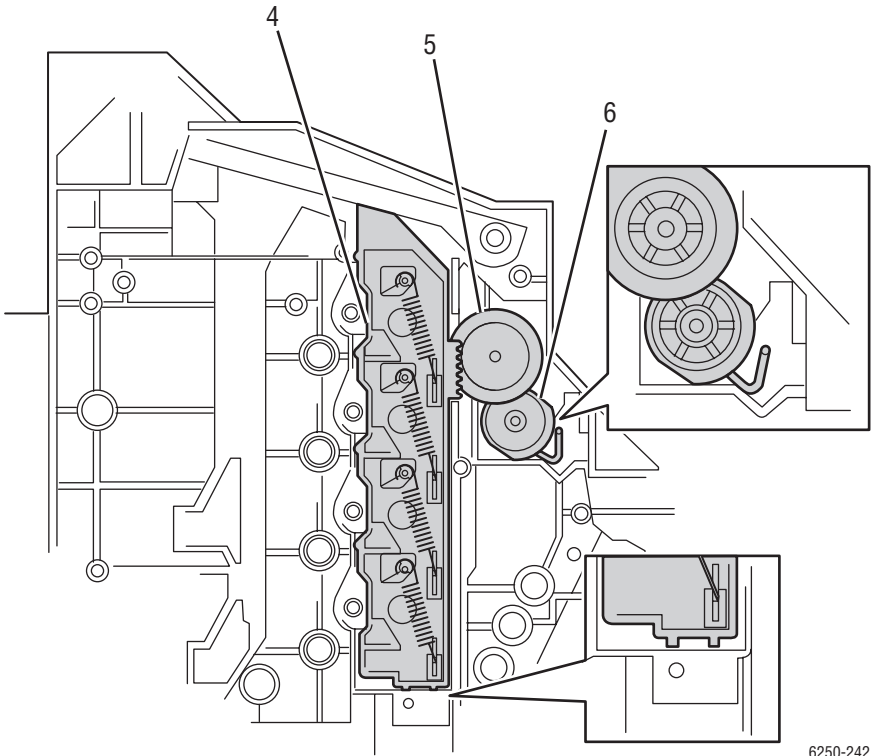

6250-242

8. Carefully remove the Left Link lever (item #4) from the printer chassis together with the springs and the drum levers (item #3).

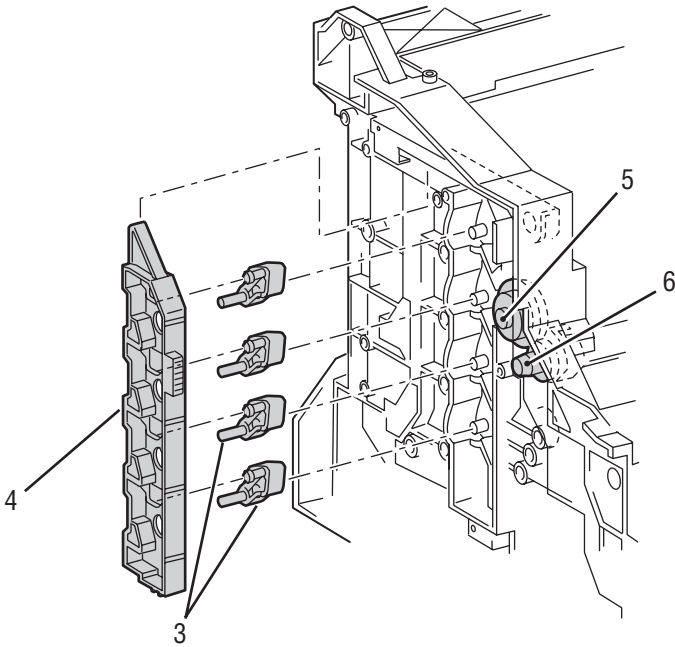

6250-239

Caution

Do not accidentally knock out the stud plungers (bias contacts).

Note

For reassembly ensure the drum levers are seated properly on the aligning posts.

Note

When replacing the Lever Link, ensure that the spring behind the Gear Press (item #6) is aligned as shown in the figure on the preceding page when the Lever Link is at the bottom of its travel as shown in the same figure.

Lever Plate Right (PL 11.1.7), Lever Bracket (PL 11.1.2), Lever Link (PL 11.1.6), Lever Drum (PL 11.1.4), and Lever Spring (PL 11.1.5)

1. Remove the Right Cover (page 8-11).
2. Remove the Top Imaging Unit Cover (Door C) (page 8-10).
3. Remove the Right Link Spring (PL1.1.22)
4. Remove the Main Drive Assembly (page 8-94).
5. Remove the Motor Driver Board.

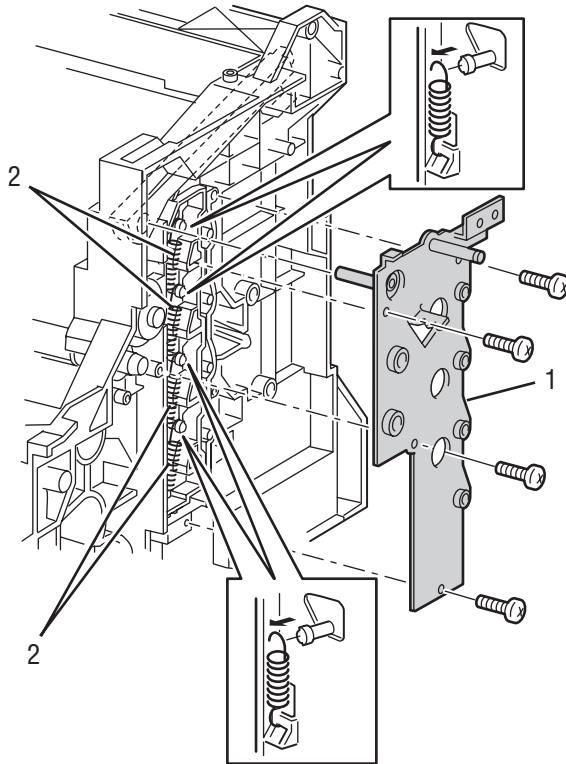

6250-222

6. Remove the 4 screws securing the Right Plate Assembly (item #1).
7. Press on the aligning post in the upper left corner of the plate from inside the cavity of the printer to remove the Plate Assembly.

8. Unhook the top end of each of the four lever springs (item #2) from the arm of the drum lever where it extends through the lever link.

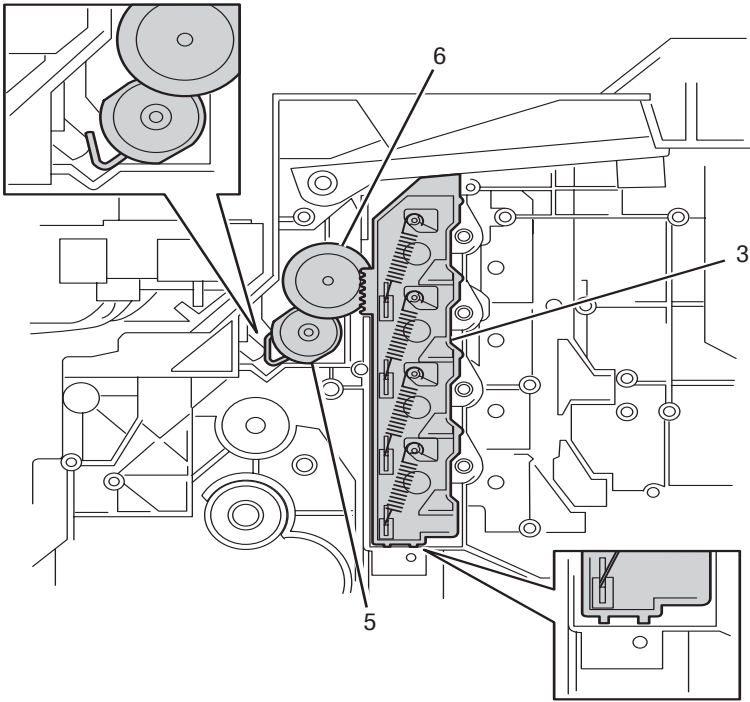

6250-243

9. Carefully remove the Right Link lever (item #3) from the printer chassis together with the springs and the drum levers (item #4).

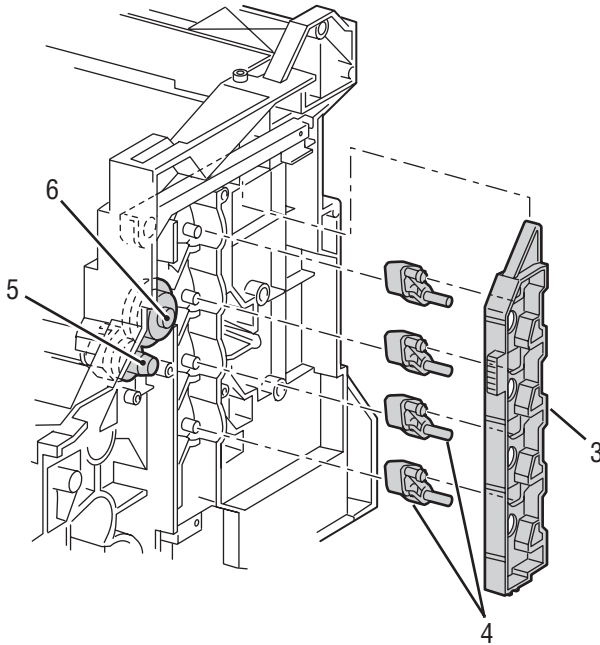

6250-240

Note

For reassembly ensure the drum levers are seated properly on the aligning posts.

Note

When replacing the Lever Link, ensure that the spring behind the Gear Press (item #5) is aligned as shown in the figure on the preceding page when the Lever Link is at the bottom of its travel as shown in the same figure.

Main Drive Assembly (PL 11.1.14)

1. Remove the Cover Top Main (page 8-9).
2. Remove the Cover Front Right (page 8-15).
3. Remove the Cover Right (page 8-11).
4. Remove the Link: Right (page 8-13).
5. Disconnect the P/J48 from the Motor Driver Board.
6. Free the harness from the clamp on the Main Drive Assembly.
7. Remove the grounding screw.
8. Remove the 3 screws securing the Main Drive Assembly to the printer.
9. Remove the Main Drive (item #1).

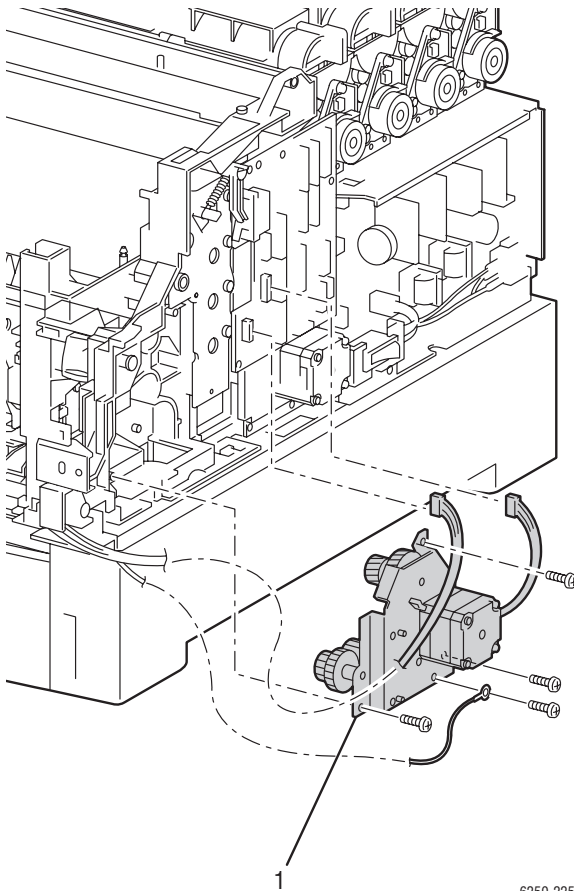

6250-225

Developer Drive Assembly (PL 11.1.13)

1. Remove the Right Cover (page 8-11)
2. Disconnect connector P/J49 from the Motor Driver Board
3. Remove the Motor Driver Board (page 8-101).
4. Remove the 4 screws securing the Developer Drive Assembly (item #1) and remove.

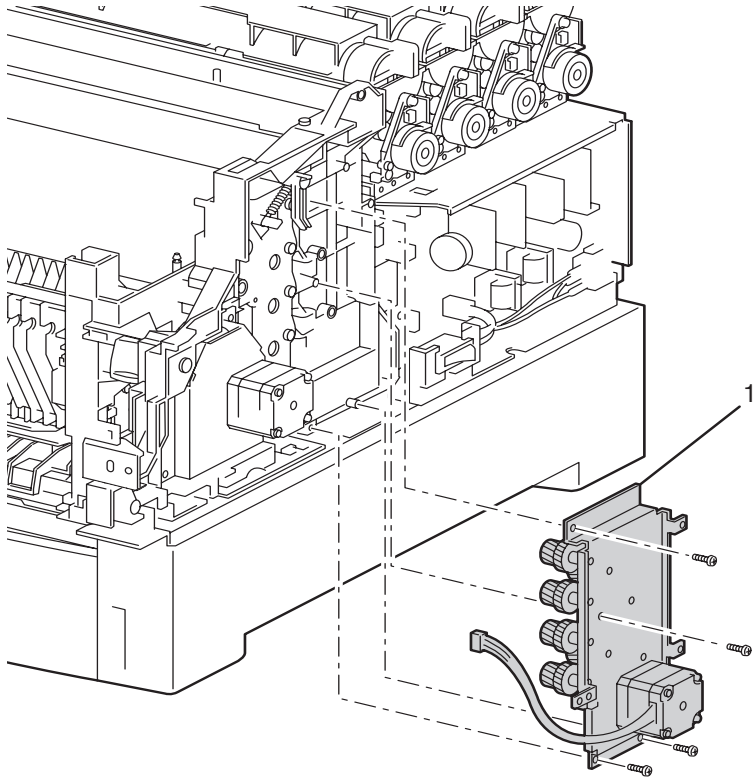

6250-224

Actuator, I/L (PL 11.1.8) and Spring, I/L (PL 11.1.9)

1. Remove the Right Cover (page 8-11)
2. Remove the 4 screws on the Motor Driver Board and set the board to the side.
3. Remove the spring from the actuator.
4. Release the hook securing the actuator (item #1) to the shaft and remove.

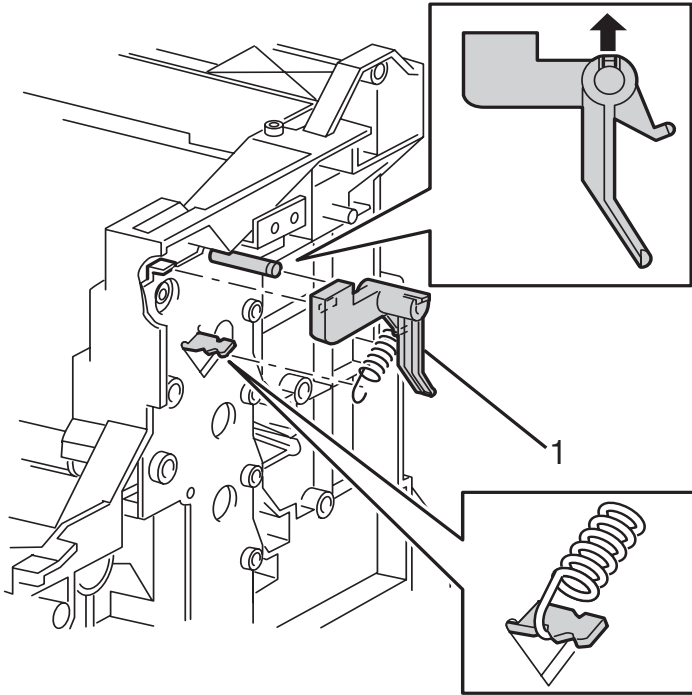

6250-223

Earth Ground Circuit Board (PL 11.1.16)

1. Remove the Fuser Assembly.
2. Remove the Transfer Roll Assembly.
3. Remove the Chute Assembly Registration (page 8-71).
4. Remove the Housing Assembly Retard (page 8-37).

Note

Loosen the screw securing the grounding strap at the left side of the board to allow removal of the board without bending the grounding strap.

5. Remove the 2 screws securing the Ground Circuit Board (item #1) and remove the board.

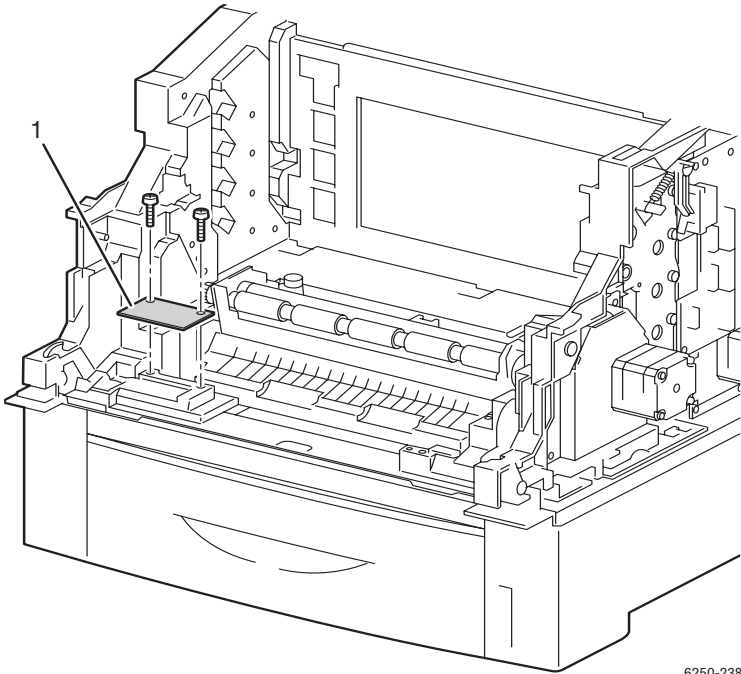

6250-238

Electrical

AC Switch Harness Assembly (PL 12.1.11)

1. Remove the Top Main Cover (page 8-9).
2. Remove the Right Cover (page 8-11).
3. Remove the screw securing the ground wire to the LVPS (item #1).
4. Release the tabs securing the harness cable guide (item #2) to the AC Switch bracket and move aside.
5. Disconnect P/J161 from the LVPS.
6. Press in on the tabs and push the AC connector to the rear, then to the side through the notch in the chassis.
7. Press in on the tabs and remove the Harness Assembly AC Switch (item #3) from the printer.

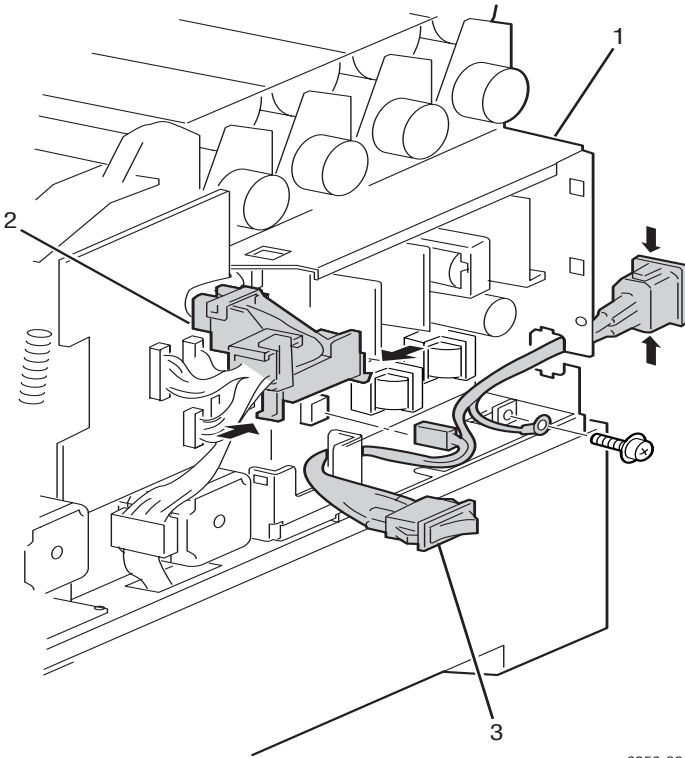

6250-231

Low-Voltage Power Supply (PL 12.1.10)

1. Remove the Imaging Unit (Routine Maintenance Item) and protect it from exposure to light.
2. Remove the Top Main Cover (page 8-9).
3. Remove the Right and Left Side Covers (page 8-11).
4. Remove the Rear Cover (page 8-12).

Note

Reinstall the toner cartridges to seal the toner system and prevent spillage.

5. Remove 4 screws above the LVPS, securing the Toner Cartridge Holder Assembly.
6. Lift the Toner Cartridge Holder off the aligning tabs and move out of the way.
7. Disconnect P/J162, P/J163, P/J164, P/J165, P/J166, and P/J168 from the Low-Voltage Power Supply Board.

Note

P/J167 and P/J168 are not used.

8. Remove the 3 screws securing the LVPS to the printer and remove the Low-Voltage Power Supply.
9. Remove the Harness Assembly AC Switch (page 8-98).

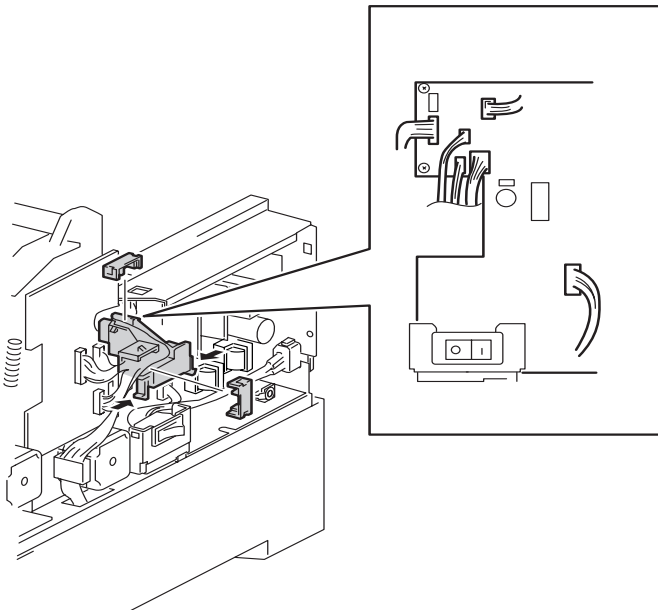

6250-229

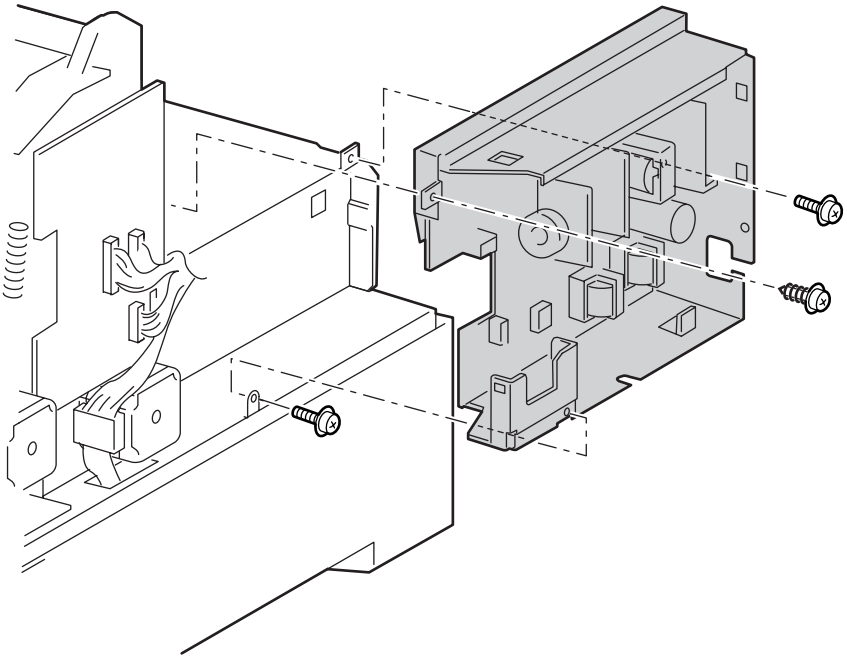

6250-230

Replacement Notes

Note

The self tapping screw goes in the upper left corner of the LVPS

Motor Driver Board (PL 12.1.12)

1. Remove the Top Main Cover (page 8-9).
2. Remove the Front Right Cover (page 8-15).
3. Remove the Right Cover (page 8-11).
4. Disconnect all the connectors on the Motor Driver Board.
5. Remove the 4 screws securing the Motor Driver Board to the printer and remove the board.

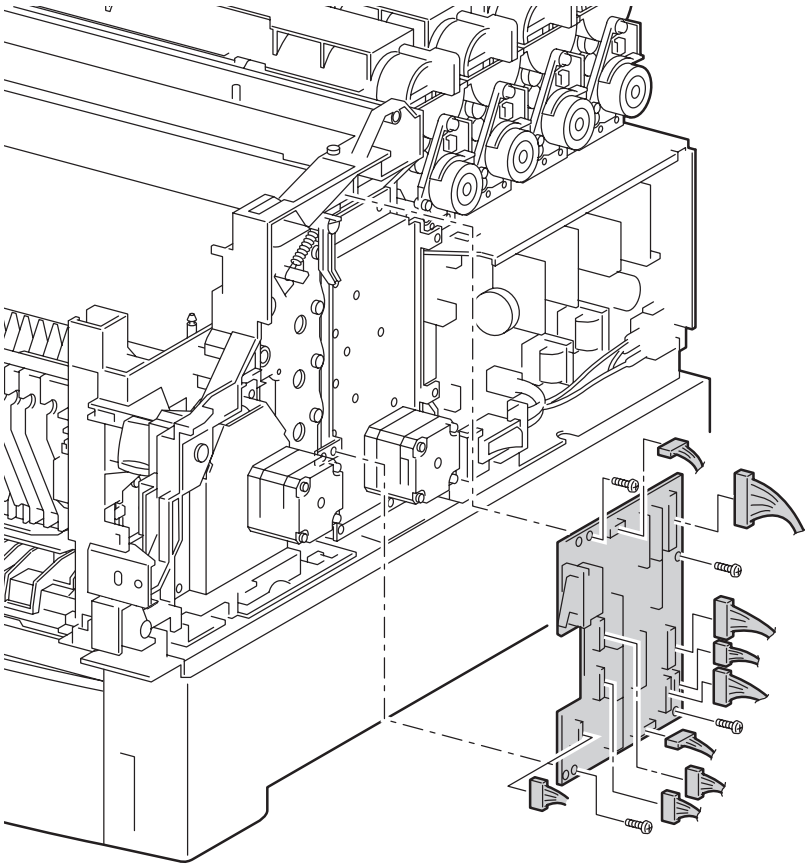

6250-232

Rear Fan (PL 12.1.2)

1. Remove the Cover Rear (page 8-12).
2. Disconnect P/J166 from the Low-Voltage Power Supply board.
3. Carefully shift the harness out of the 4 hooks on the Toner Cartridge Holder Assembly.
4. Remove the 2 screws securing the Rear Fan to the printer and remove the fan.

Replacement Notes

Note

When replacing the fan note the airflow direction, the label side should face out.

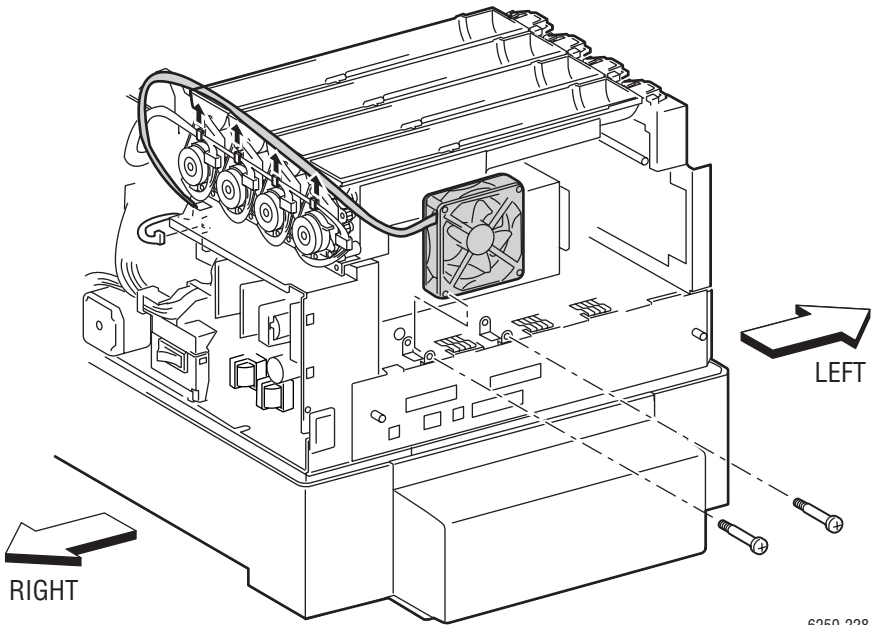

6250-228

Card Cage

Note

You do not need to remove the Laser Unit.

Caution

Remove the Chute Assembly Registration and the Housing Assembly Bias PRIOR to removing the Card Cage to prevent damaging the Bias Springs.

1. Remove the Chute Assembly Registration (page 8-71).
2. Remove the Housing Assembly Bias (page 8-69).
3. Disconnect P/J151 from the Laser Unit.
4. Disconnect P/J3411 from the CRUM Reader located above the Card Cage.
5. Disconnect P/J210 from the Paper Tray Feeder on the right side of the printer.
6. Disconnect P/J 41 and P/J 42 from the Motor Driver Board.
7. Disconnect P/J 164 and P/J 168 from the LVPS.
8. Remove the cable guide retainers and remove the cable guide on the right side of the printer above the power switch.
9. Remove P/J 5011 from the Sub-HVPS, and free it from the cable clamp.
10. Disconnect P/J19 (blue) from the Engine Control Board (under the Housing Assembly Electric).

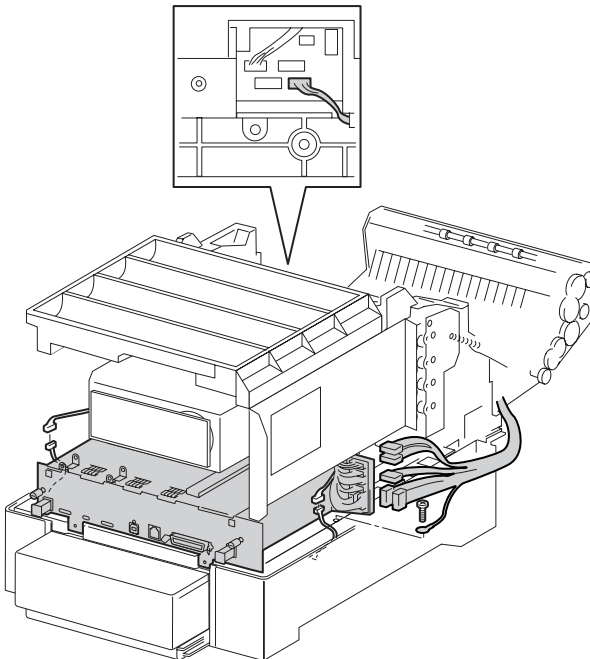

6250-234

11. Disconnect P/J 2361 (yellow wires) going to the Temperature/Humidity Sensor.
12. Disconnect P/J 144 (yellow wires) from the EEPROM Board (PL 10.1.14).
13. At the front of the card cage, remove the two screws from the metal of the card cage, not the two screws secured in the plastic (see the following figure).

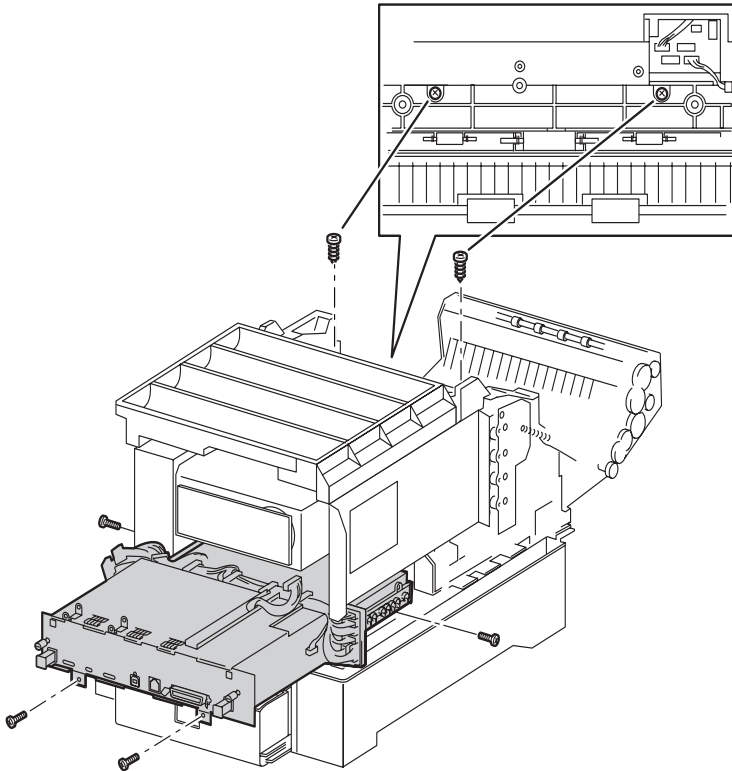

6250-235

14. Remove the two mounting screws for the Rear Fan and move it out of the way.

Caution

Note the fan orientation for reassembly, the label should face out towards the rear of the printer.

Note

A total of 6 screws including the 2 removed in Step 13) secure the Card Cage. The remaining 4 are located as follows: 2 on the rear under the card cage, 1 on the left side below the Sub-HVPS board, and 1 on the right at the rear of the LVPS.

15. Remove the 4 screws still securing the Card Cage to the printer and remove the card cage.

16. Carefully slide the Card Cage free while ensuring that cables do not catch and get damaged.

Replacement Notes

Caution

When reinstalling the Card Cage, make sure the Chute Assembly Registration and the Housing Assembly Bias are installed **after** reinstalling the Card Cage to prevent damaging the bias springs.

Note

The black connector P30 and the beige connector P23 on the Engine Control Board are not used.

Housing Assembly Contact (PL 12.1.14)

1. Remove the Card Cage Assembly (page 8-103).
2. Release the 2 tabs securing the Housing Assembly Contact to the Card Cage and remove the Housing Assembly Contact.

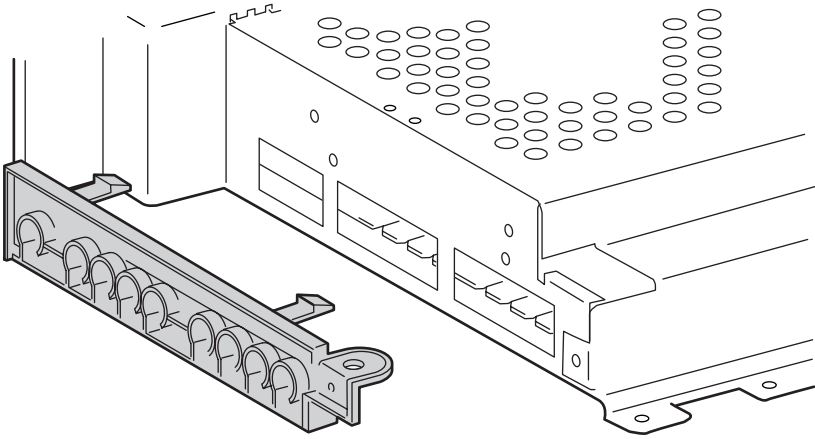

6250-233

Replacement Notes

Note

Insert the rear tab first for easier reassembly. Ensure that the assembly is fully seated.

Engine Control Circuit Board (PL12.1.1)

Caution

Critical printer specific information is stored in the engine NVRAM. Save this information to the Image Processor Board using the Service Diagnostic **NVRAM Access/MCU NVRAM Store/Restore** function. Detailed information is provided in "Service Diagnostic Tests" on page 3-9. If the printer is not functional, or optionally even if it is, restore the information by swapping the NVRAM following board replacement.

1. If the printer is functional, save the information in the engine NVRAM using the Service Diagnostic **NVRAM Access/MCU NVRAM Store** function before starting disassembly.

Caution

Observe proper ESD procedures (page 8-3) when removing any circuit board from the printer.

2. Remove the Image Processor Board (page 8-110).
3. Remove the Card Cage (page 8-103).
4. Remove the Housing Assembly Contact (page 8-106).
5. Remove the 4 screws securing the Cover Engine Control Board to the Card Cage.

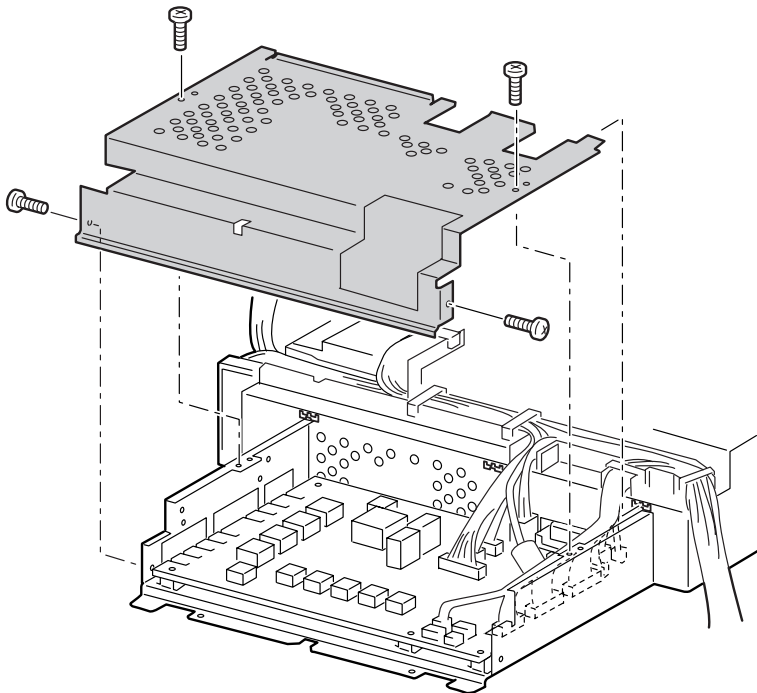

6250-226

6. Disconnect all connectors on the Engine Control Board.
7. Remove the 6 screws securing the Engine Control Board to the Card Cage and remove the board.

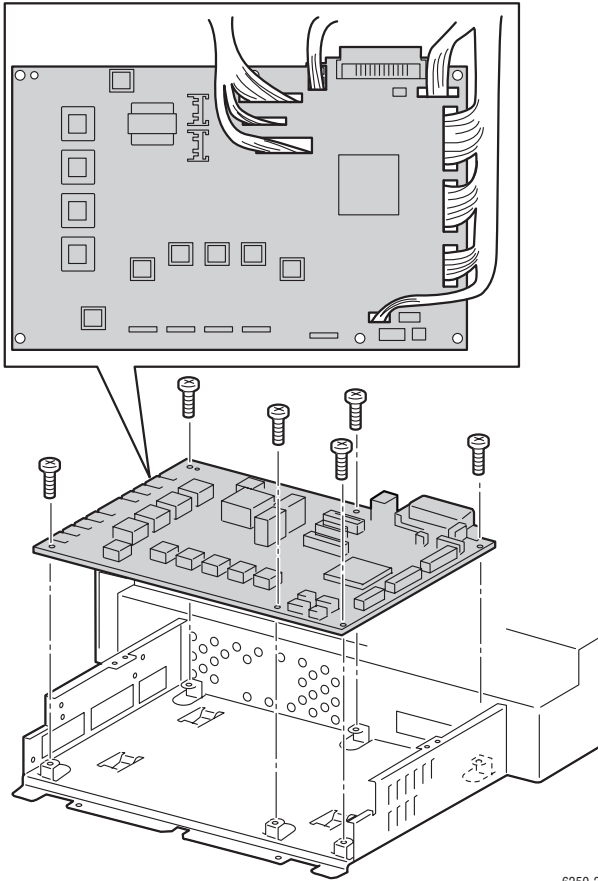

6250-227

Replacement Notes

Note

After the Engine Control Board is replaced, NVRAM data saved prior to replacement must be restored to the new board. Use the Service Diagnostic **NVRAM Access/MCU NVRAM Restore** function to restore the data. Detailed information is provided in "Service Diagnostic Tests" on page 3-9. If the printer was previously not functional, or optionally even if it was, move the NVRAM from the old board over to the new board.

Caution

Re-install the Engine Control Board and the Card Cage prior to installing the Chute Assembly Registration and the Housing Assembly Bias to prevent damaging the bias springs.

Caution

Position the replacement board so that the alignment pin goes through the hole next to the left rear screw hole in the board.

Note

Ensure that all 3 tabs on the card cage are fully inserted when reassembling the unit.

Note

The black connector P30 and the beige connector P23 on the Engine Control Board are not used.

Image Processor Board (PL12.1.4)

Caution

Observe proper ESD procedures (page 8-3) when removing any circuit board from the printer.

1. Turn the printer power off.
2. Disconnect any cables attached to the Image Processor board.
3. Loosen the 2 thumb screws securing the Image Processor board to the printer.
4. Holding both knobs on the Image Processor board, pull the board straight out from the printer to remove.

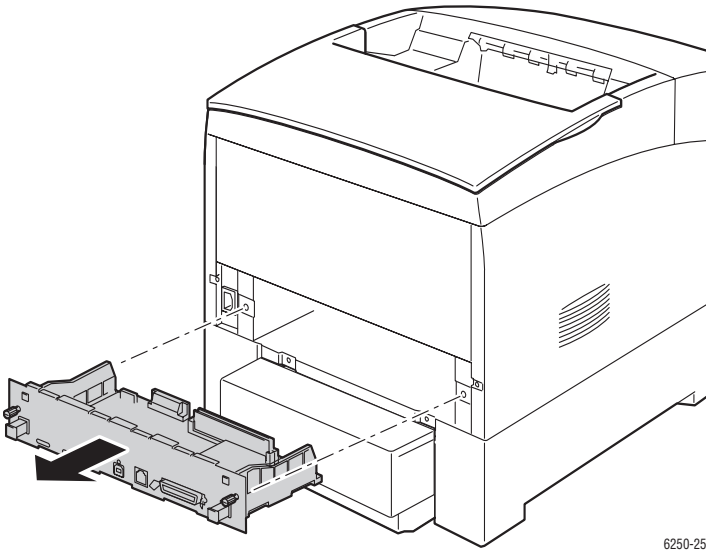

Replacing the Board

The following items **MUST** be moved from the original Image Processor Board to the new board. See "Image Processor Board" on page 9-32 for the exact locations of each component.

- Memory
- Hard Drive (if installed)
- Configuration Upgrade Chip ('i' Button)
- NVRAM

Print a Configuration Page after the new board is installed to ensure the customers configuration is correct.

Optional High Capacity Feeder Disassembly

Cover Front (PL14.2.4)

1. Remove Paper Trays 3 and 4.
2. Carefully pry up on the 3 tabs securing the Cover Front to the frame and remove the Cover Front.

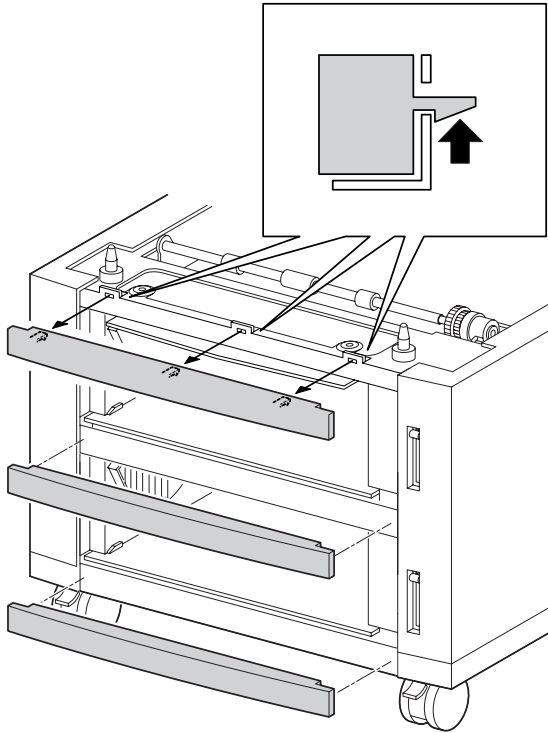

6250-267

Reassembly

Note

When replacing the Cover Front note the orientation. Align the edge with the slit in the Feeder Frame.

Cover, Right (PL14.2.1) and Cover, Left (PL14.2.3)

1. Remove Paper Trays 3 and 4.
2. Remove the Front Covers (page 8-111).
3. Remove the 5 screws securing the Cover Right and the 5 screws securing the Cover Left.
4. Holding both ends of the cover, lift the cover and move left and right, flexing slightly, to release the tabs from the holes in the Feeder frame.
5. Slide the cover toward the front to remove the Indicator Assembly.

Note

The Indicator Assembly flags will pop off.

6. Remove the Cover Right / Left.

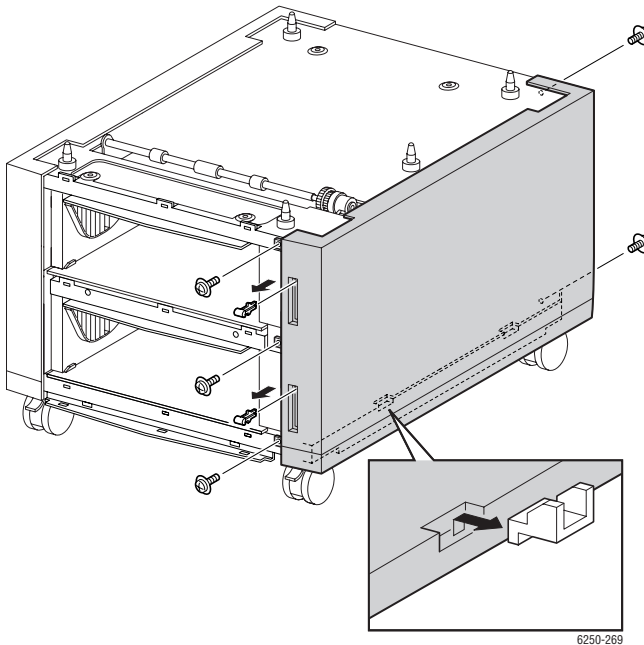

Turn Chute Assembly (PL14.3.7)

1. Remove both Paper Trays from the HCF.
2. Holding the Chute Assembly Turn, grip at both ends, push it down and release the 2 tabs from the hole in the Fame Top.
3. Release the tabs securing the Chute Assembly Turn to the Tray Guide Left and Right and remove the Chute Assembly Turn.

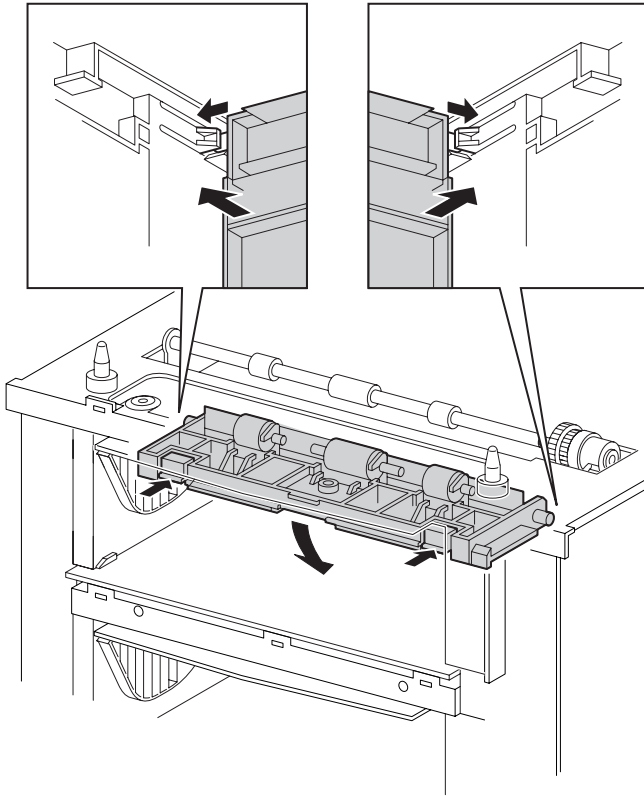

6250-270

Tray 3 Harness Assembly (PL14.5.3), Tray 4 Harness Assembly (PL14.5.4), and HCF Plug Harness Assembly (PL14.5.2)

1. Remove both Paper Trays from the HCF Assembly.
2. Remove the Front Covers (page 8-111).
3. Remove the Cover Right (page 8-112).

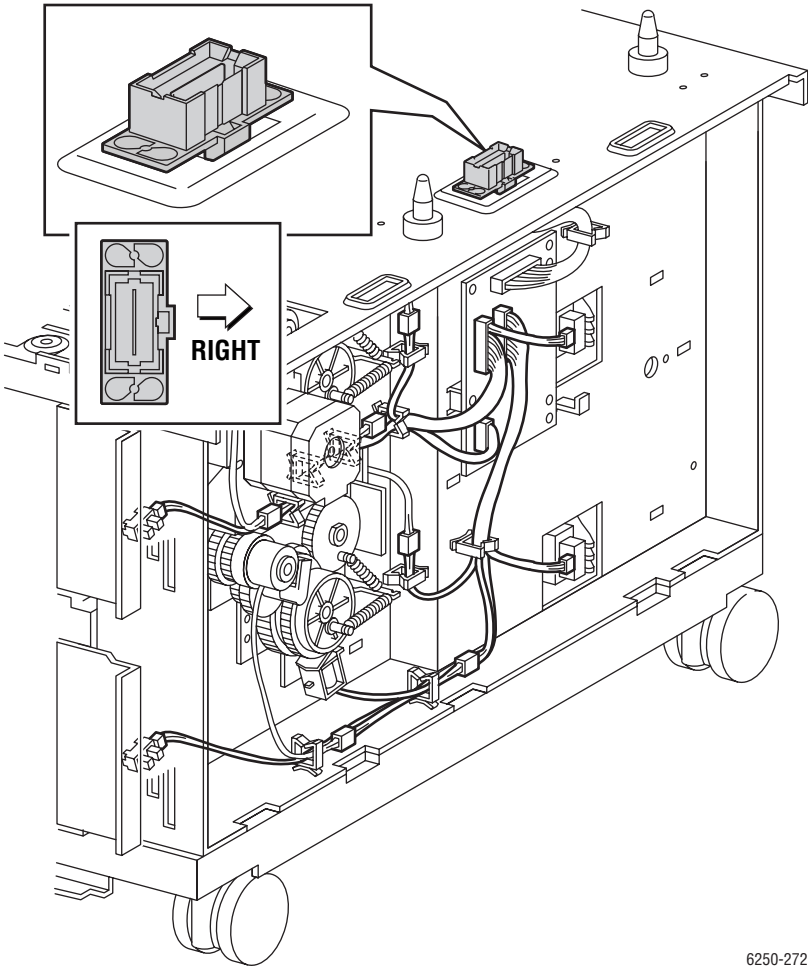

6250-272

Harness Assembly Tray 3

1. Disconnect P/J82 (gray) from the HCF Circuit Board
2. Remove the Harness Assembly Tray 3.

Harness Assembly Tray 4

1. Disconnect P/J83 (blue) from the Power Feeder Circuit Board and remove the Harness Assembly Tray 4.

Harness Assembly Feeder Plug

Note

The wide slot in the middle of the plug faces outward. The tabs on the bottom of J810 can be easily damaged during the removal process.

1. Disconnect P/J81 (yellow) from the Power Feeder Circuit Board.
2. Remove J810 by lifting out of the hole in the top of the HCF frame.
3. Lift the entire Harness Assembly Feeder Plug through the hole in the top of the HCF frame.

Circuit Board, HCF (PL14.5.1)

1. Remove both Paper Trays from the HCF.
2. Remove the Front Covers (page 8-111).
3. Remove the Cover Right (page 8-112).
4. Disconnect P/J81 from the Harness Feeder Plug Assembly.
5. Disconnect P/J82 from the Harness Assembly Tray 3.
6. Disconnect P/J83 from the Harness Assembly Tray 4.
7. Disconnect P/J84 from the Drive Assembly.
8. Remove the 3 screws securing the Power Feeder Circuit board to the HCF frame and remove the board.

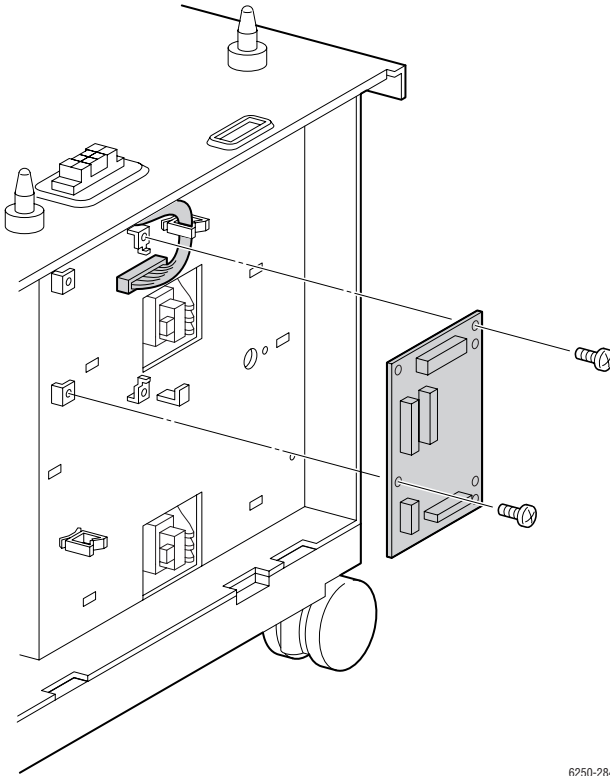

6250-284

Replacement Notes

Note

When replacing the Power Feeder Circuit Board, align the hole on the board and the two tabs on the HCF Frame.

Drive Feeder Assembly (PL14.5.5)

1. Remove both Paper Trays from the HCF.
2. Remove the Front Covers (page 8-111).
3. Remove the Right Cover (page 8-112).
4. Release the Tray 2 Harness Assembly (gray) from the cable restraints.
5. Disconnect P/J84.
6. Remove the 3 screws securing the Feeder Drive Assembly to the HCF and remove.

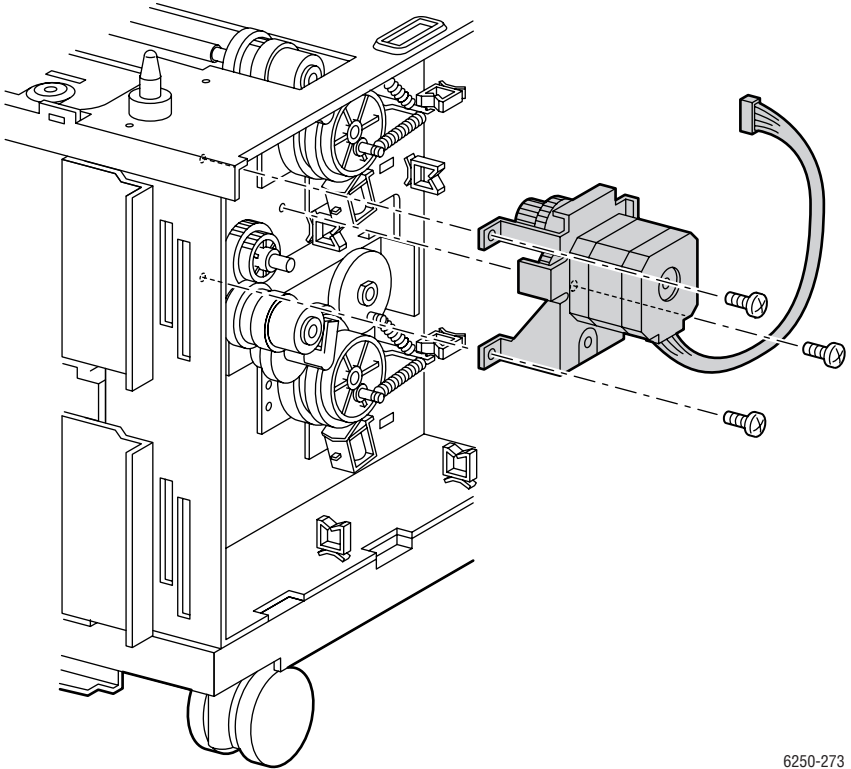

6250-273

Indicator Assembly (PL14.5.9)

1. Remove both Paper Trays from the HCF.
2. Remove the Front Covers (page 8-111).
3. Remove the Right Cover (page 8-112).
4. Push down on the black bearing, on the top of the indicator shaft, lift up on the shaft and pull out of the hole in the HCF frame.

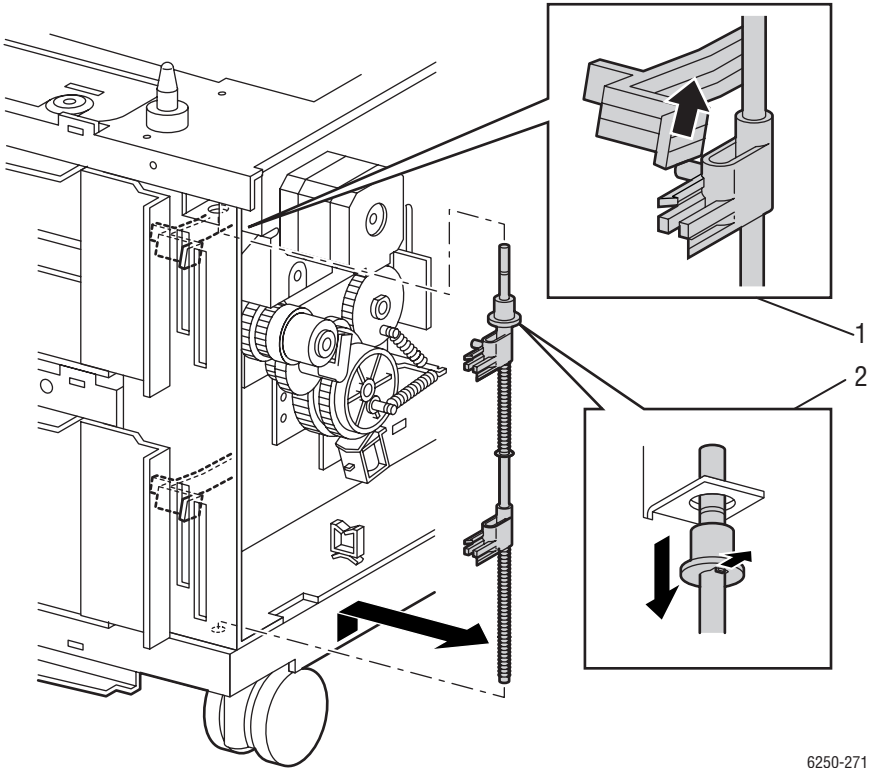

6250-271

Reassembly

Note

The Indicator Assembly has to be below the Low Paper Lever.

Right Tray Guide (PL14.3.5) and Low Paper Lever (PL 14.5.8)

Guide Assembly Paper Tray Right

1. Remove both Paper Trays from the HCF.
2. Remove the Front Covers (page 8-111).
3. Remove the Right Cover (page 8-112).
4. Remove the Turn Chute Assembly (page 8-113) .
5. Remove the Feeder Drive Assembly (page 8-117).
6. Remove the Indicator Assembly (page 8-118).
7. Remove the HCF Circuit Board (page 8-116).
8. Remove the 1 screw securing the Low Paper Bracket to the HCF frame.
9. Remove the Bracket.

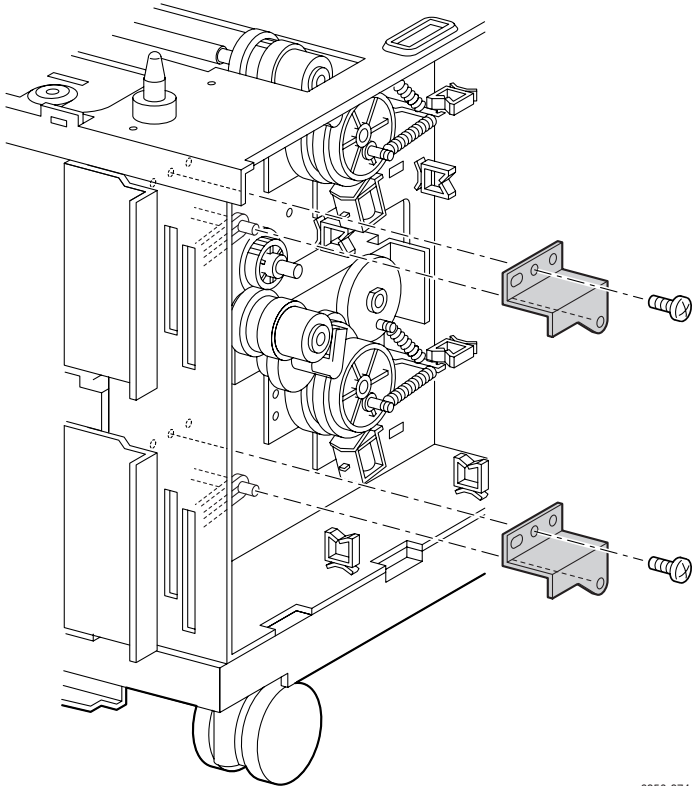

6250-274

10. Remove the 5 screws securing the Right Tray Guide to the HCF frame.

11. Release the 7 tabs securing the Right Tray Guide to the HCF frame.

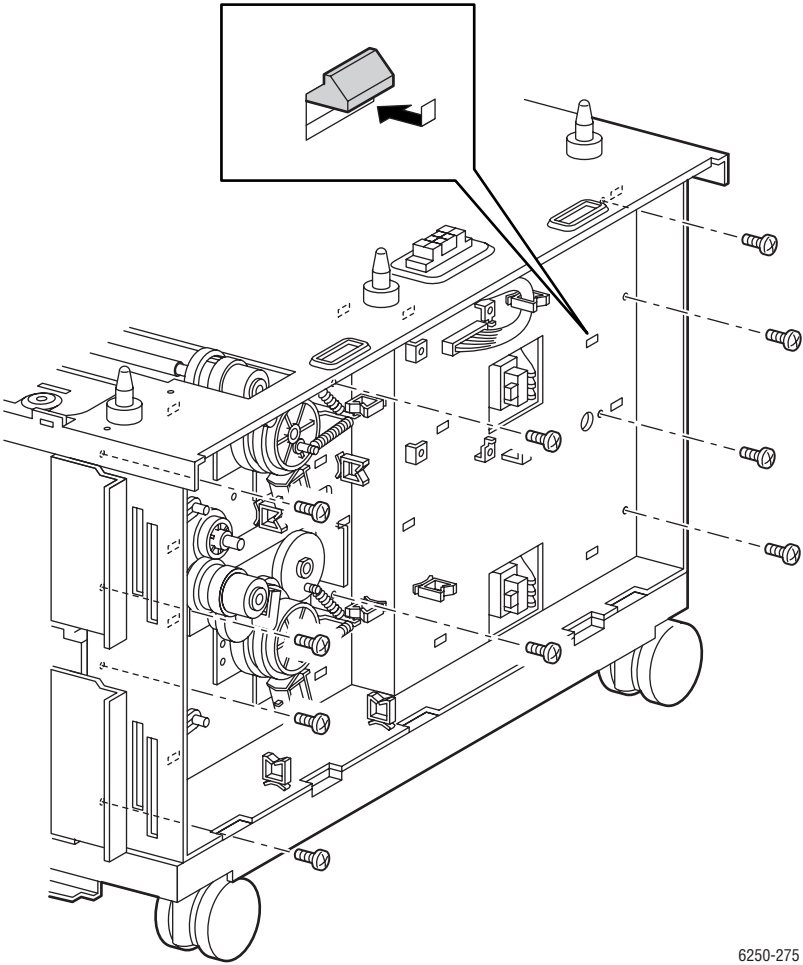

6250-275

12. Carefully remove the Low Paper Lever from the slit in the Right Tray Guide.

13. Remove the Guide Assembly Right by rotating the top in.
14. Repeat Steps 11 - 14 to remove the lower guide.

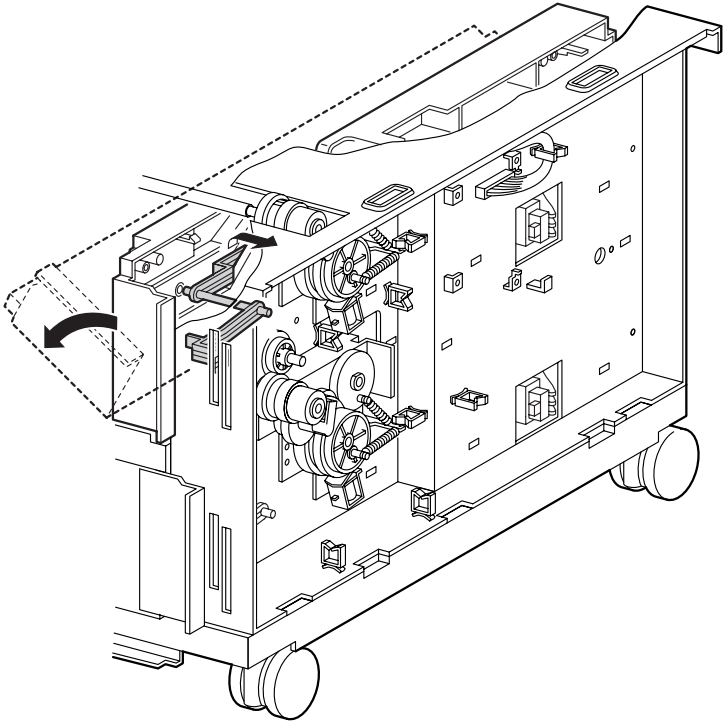

6250-276

Left Tray Guide (PL14.3.3)

1. Remove both Paper Trays from the HCF.
2. Remove the Front Covers (page 8-111).
3. Remove the Left Cover (page 8-112).
4. Remove the Turn Chute Assembly (page 8-113).
5. Remove the 5 screws securing the Left Tray Guide Assembly to the HCF frame.
6. Release the 6 tabs securing the Left Tray Guide Assembly to the HCF frame.

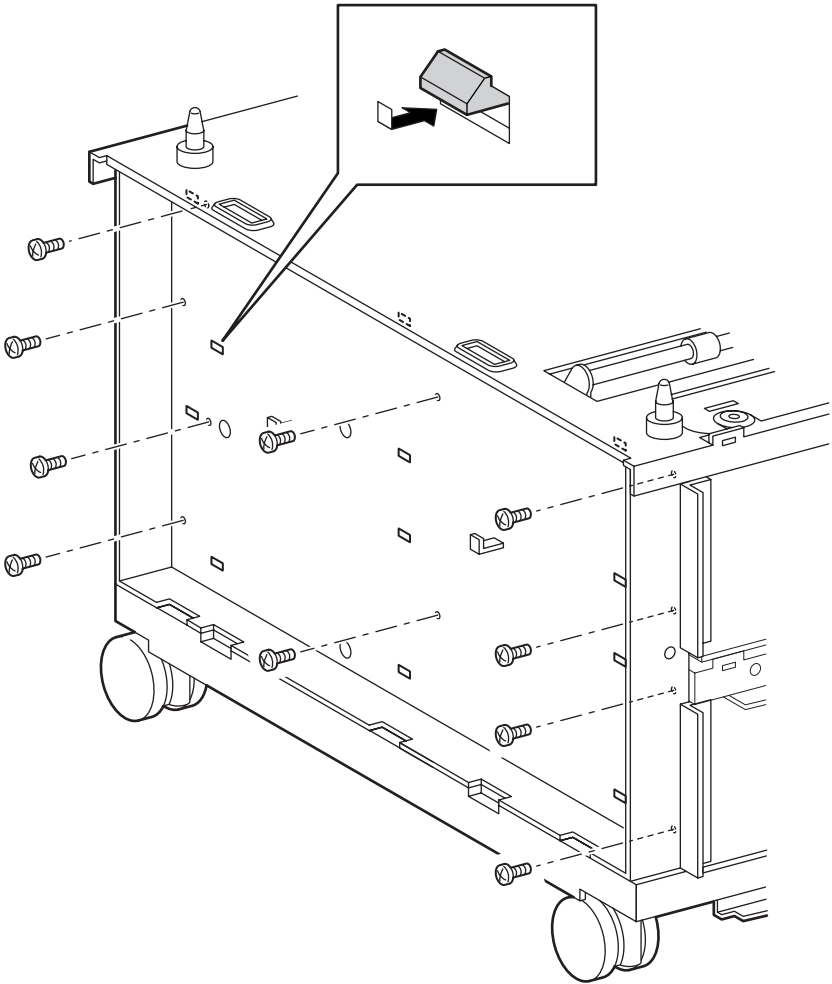

6250-277

7. Remove the Guide Assembly by rotating the top inward.

8. Repeat Steps 1 - 7 to remove the lower guide.

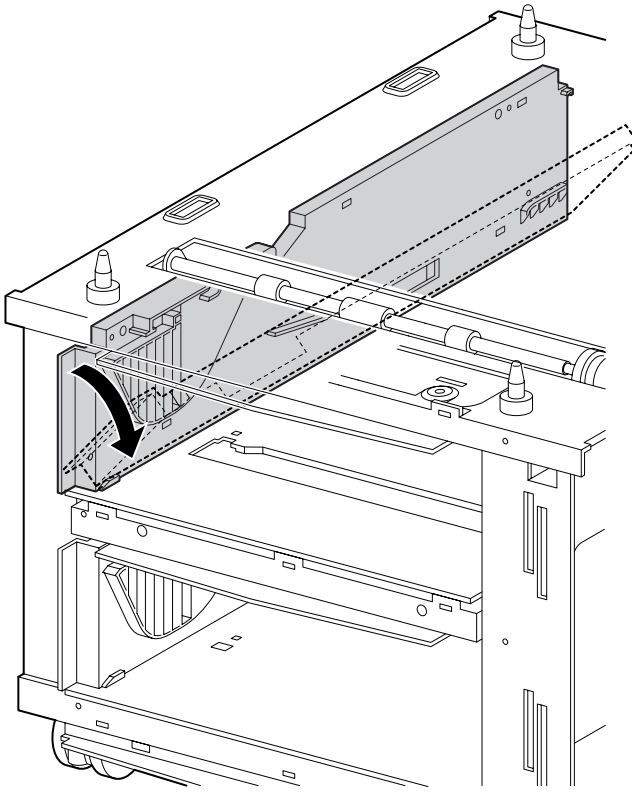

6250-278

Link Actuator (PL 14.4.6)

1. Remove both Paper Trays from the HCF.
2. Remove the paper tray Rear Cover.
3. Reach in through the rear of the printer and spread the tabs of the Link Actuator apart.
4. Remove the link actuator from the bracket in the printer.
5. Remove the actuator.

Note

When replacing, position the Actuator so that the wider portion is on the right side view from the front. Replace it after passing the tip of the Link Actuator into the hole in the HCF frame.

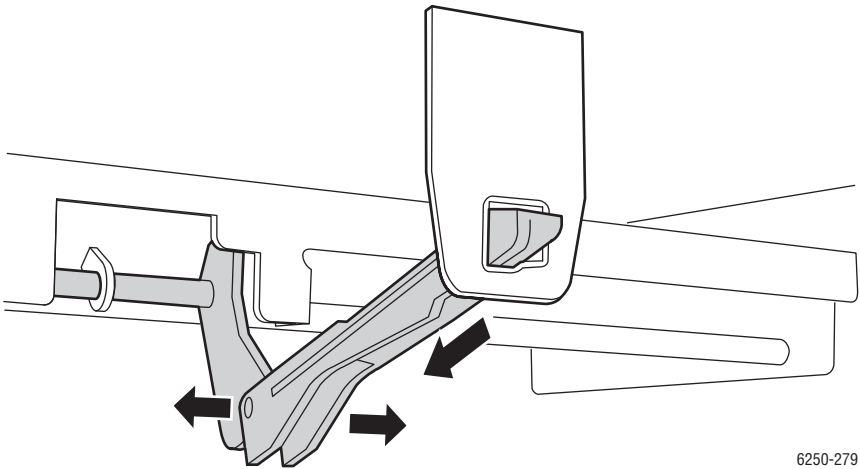

6250-279

HCF Paper Pick Assembly (PL14.4.1)

1. Remove the Right and Left Tray Guide Assemblies (page 8-119) and (page 8-122).
2. Remove the Link Actuator (page 8-124).
3. Remove the 2 screws securing the Paper Pick Assembly to the right side of the HCF frame.
4. Release 2 tabs on the Paper Pick Assembly from the 2 slits and window on the left side of the HCF frame.
5. Disconnect P/J824, P/J8220 and P/J825.
6. Remove the Paper Pick Assembly through the window.

Note

When removing or replacing the the screws, be careful not to damage the Gear or Spring with the screwdriver. When passing the Paper Pick Assembly through the window, be careful not to damage the rubber parts.

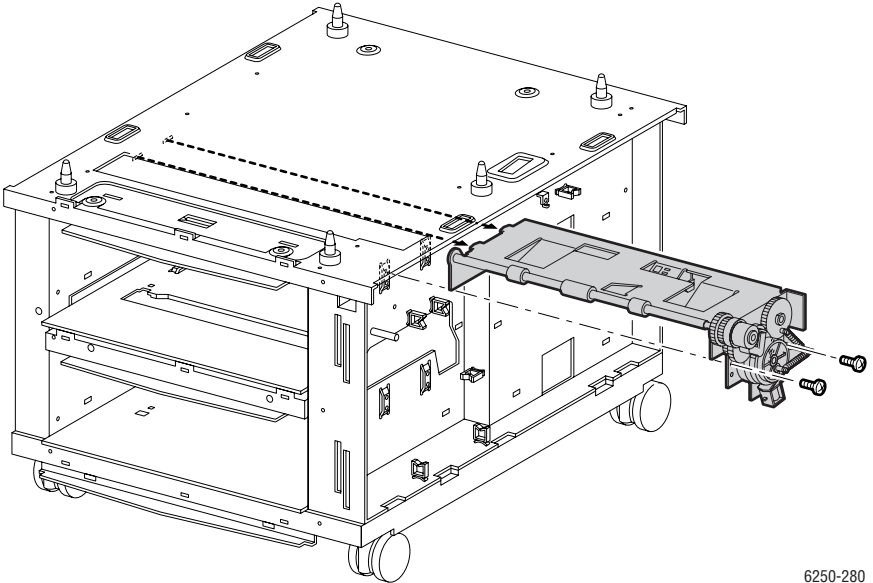

6250-280

Idler Gear (PL14.5.6)

1. Remove the Tray 4 Guide Assembly Right and Left (page 8-119) (page 8-122).
2. Remove the Link Actuator (page 8-124).
3. Remove the Paper Pick Assembly for Tray 4 (page 8-125).
4. Remove the Gear Idler.

Note

When replacing, the larger side of the gear must face the HCF frame.

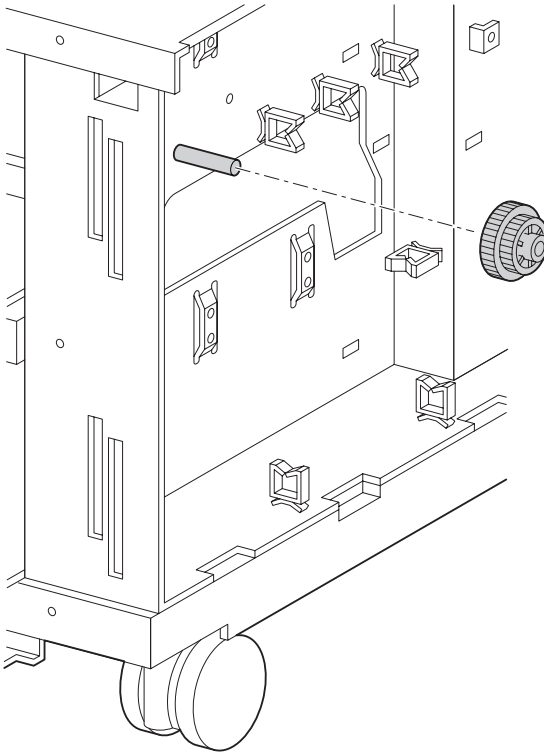

6250-282

No Paper, Low Paper Sensor (PL14.5.7)

1. Remove the Paper Trays.
2. Remove the Cover Front (page 8-111).
3. Remove the Cover Right (page 8-112).
4. Remove the Turn Chute Assembly (page 8-113).
5. Remove the Indicator Assembly (page 8-118).
6. Remove the Bracket Low Paper, upper and lower.
7. Remove the HCF Circuit Board (page 8-116).
8. Remove the Right Tray Guide (page 8-119).
9. Release the 3 tabs securing the Sensor to the HCF frame and remove the sensor.

Note

Use caution, the Sensor tabs are easily broken.

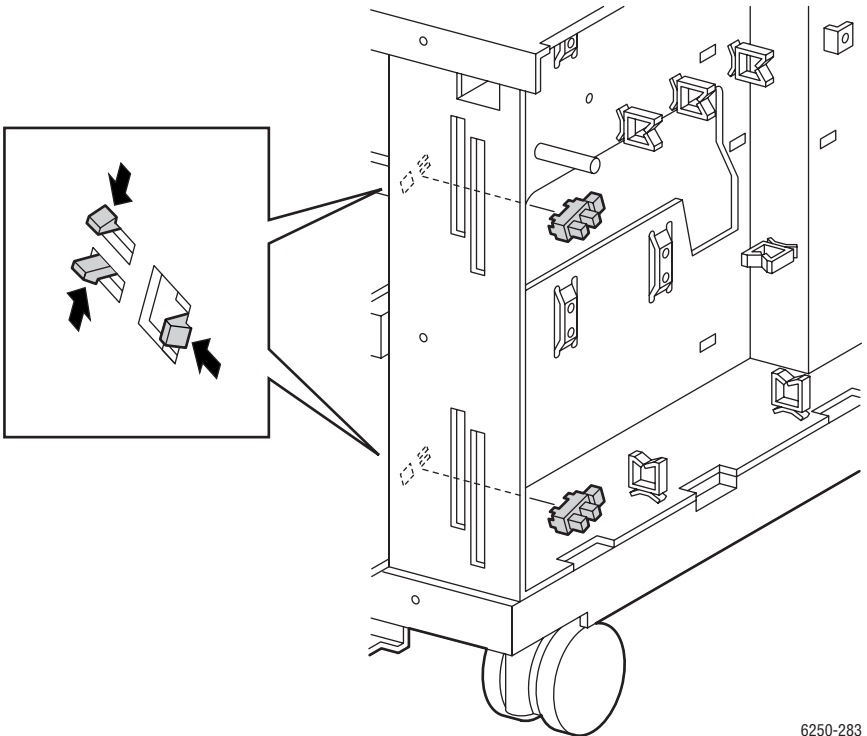

6250-283

Paper Size Switch Assembly (PL14.3.6)

1. Remove the Right Tray Guide Assembly (page 8-119).
2. Remove the 1 screw securing the Paper Size Switch to the Right Guide Assembly and remove the switch.

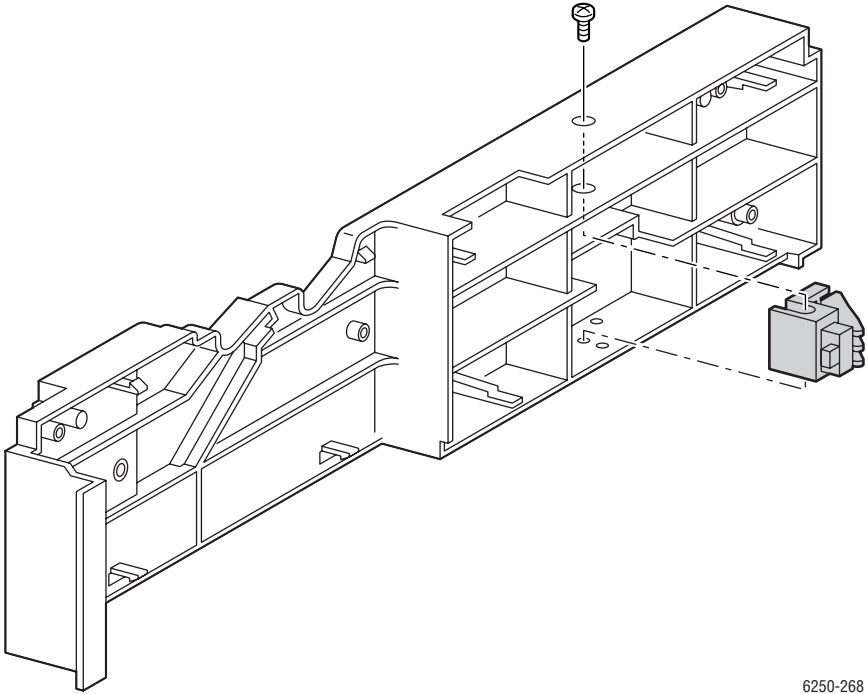

6250-268

Casters, Locking (PL 14.2.5)/Non-Locking (PL 14.2.6)

1. Remove both paper trays from the HCF.
2. Turn the HCF upside down to access the casters.
3. For the Locking (front) Casters only, remove 1 screw securing the Guide, Caster (item #1) (PL 14.2.8) to the bottom of the HCF and remove the Guide.

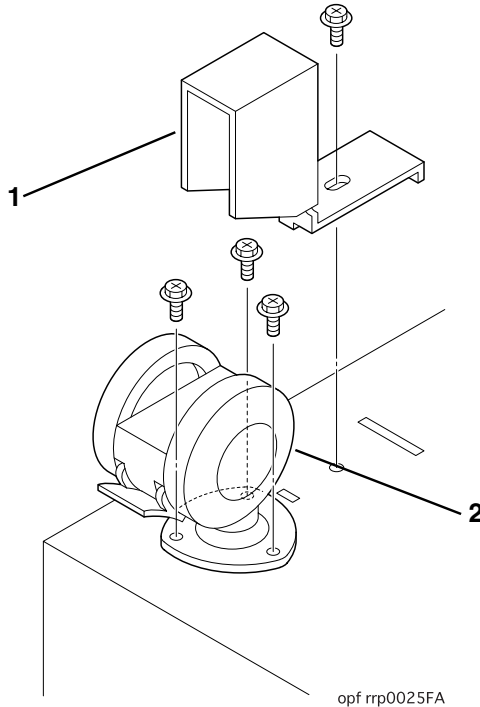

4. Remove the 3 screws securing the Caster (item #2) (PL 14.2.5 or PL 14.2.6) to the bottom of the HCF and remove the Caster.

Replacement Notes

Note

When replacing the Locking (front) Casters, ensure that the Caster is facing forward as shown in the preceding figure before replacing the Guide, Caster.

Optional 500-sheet Feeder Disassembly

Cover Front (PL15.2.4)

1. Remove Paper Tray 3.
2. Carefully pry up on the 3 tabs securing the Cover Front to the frame and remove the Cover Front.

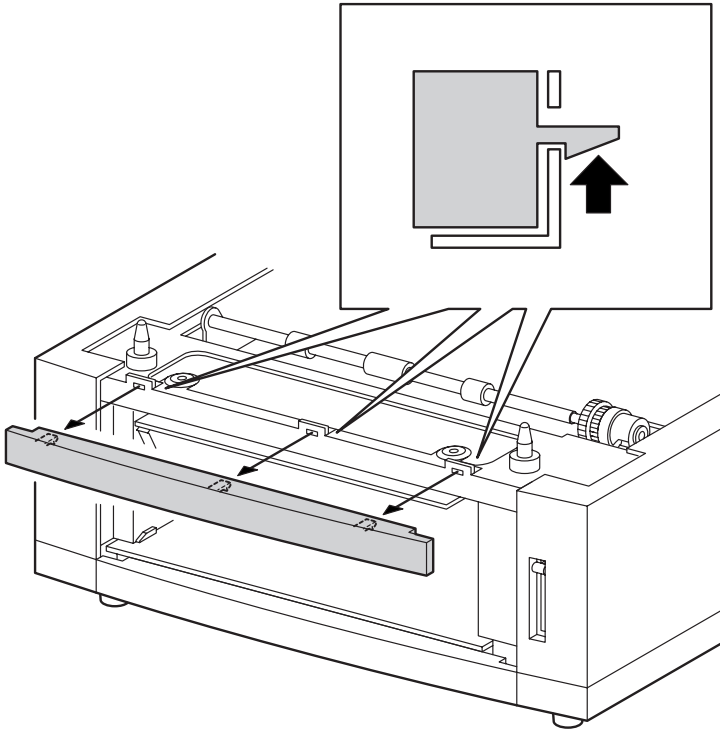

6250-408

Reassembly

Note

When replacing the Cover Front note the orientation. Align the edge with the slit in the Feeder Frame.

Cover, Right (PL15.2.2) and Cover, Left (PL15.2.1)

1. Remove Paper Tray 3.
2. Remove the Front Covers (page 8-130).
3. Remove the 4 screws securing the Cover Right and the 4 screws securing the Cover Left.
4. Holding both ends of the cover, lift the cover and move left and right, flexing slightly, to release the tabs from the holes in the Feeder frame.
5. Slide the cover toward the front to remove the Indicator Assembly.

Caution

Do not pull sideways on the cover as you may break the Indicator Mounting Arm. The Indicator Assembly flag will pop off as the cover slides forward, do not lose the flag.

6. Remove the Cover Right / Left.

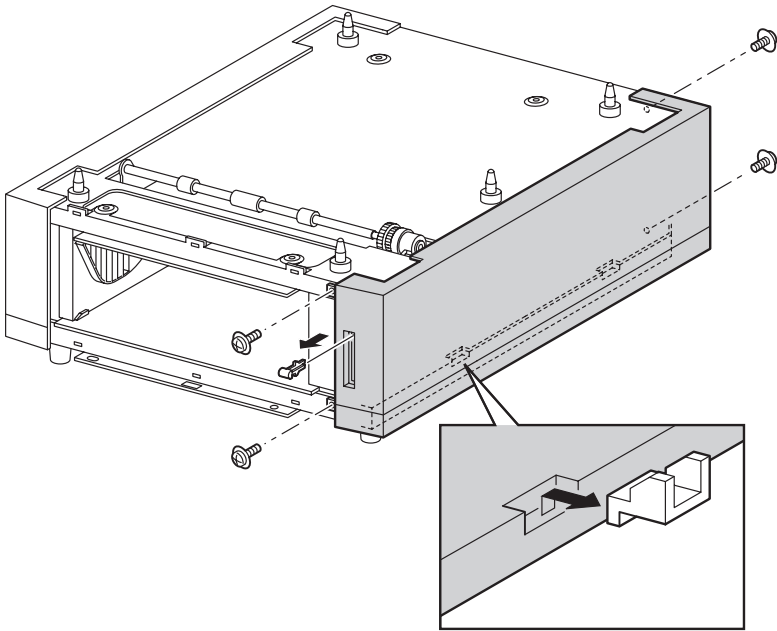

Reassembly

Note

The Indicator Assembly has to be below the Low Paper Lever. Push the indicator about halfway down before inserting the flag.

Turn Chute Assembly (PL15.3.9)

1. Remove the Paper Tray from the 500-sheet Feeder.
2. Holding the Chute Assembly Turn, grip at both ends, push it down and release the 2 tabs from the hole in the Frame Top.
3. Release the tabs securing the Chute Assembly Turn to the Tray Guide Left and Right and remove the Chute Assembly Turn.

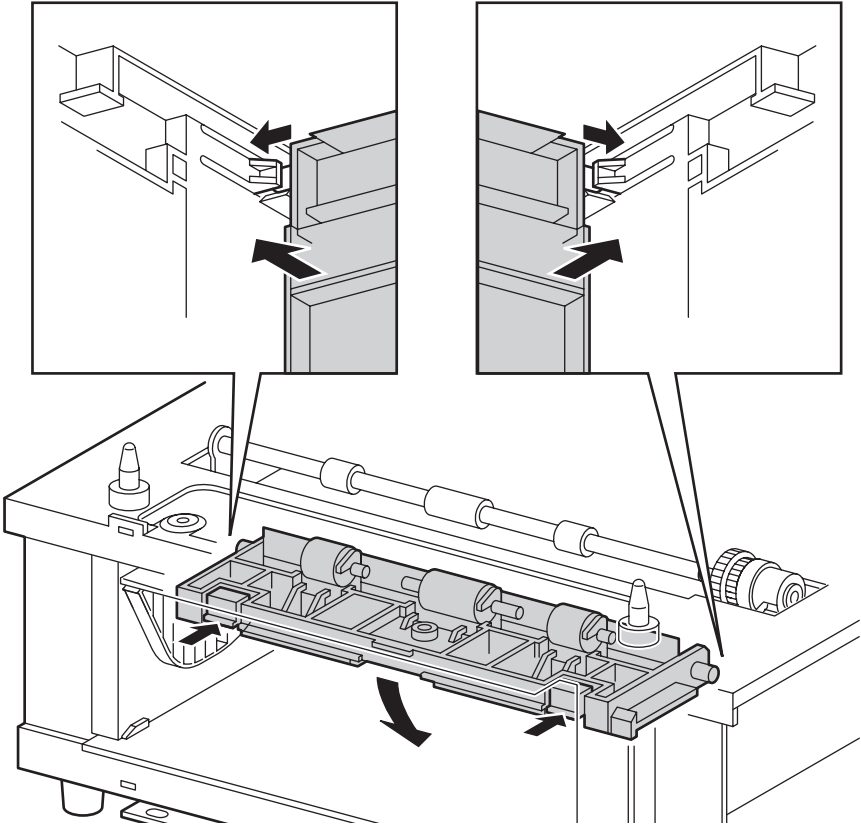

Tray 3 Harness Assembly (PL15.5.3) and STF Plug Harness Assembly (PL15.5.2)

1. Remove the Paper Tray from the STF Assembly.
2. Remove the Front Covers (page 8-130).
3. Remove the Cover Right (page 8-131).

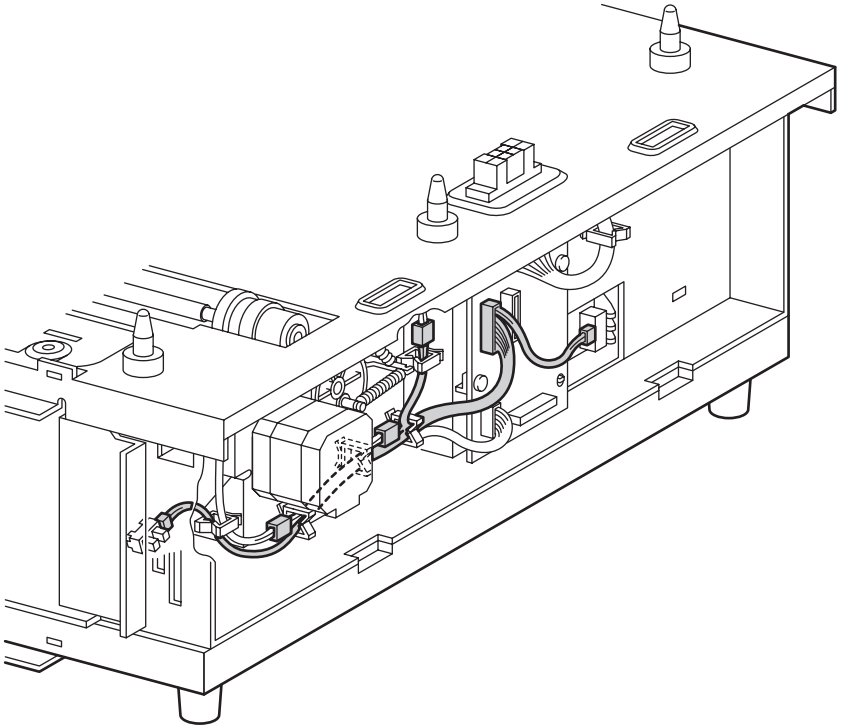

6250-413

Harness Assembly Tray 3

1. Disconnect P/J82 (gray) from the STF Circuit Board
2. Remove the Harness Assembly Tray 3.

Harness Assembly Feeder Plug

Note

The wide slot in the middle of the plug faces outward. The tabs on the bottom of J810 can be easily damaged during the removal process.

1. Disconnect P/J81 (yellow) from the Power Feeder Circuit Board.
2. Remove J810 by lifting out of the hole in the top of the STF frame.
3. Lift the entire Harness Assembly Feeder Plug through the hole in the top of the STF frame.

Circuit Board, STF (PL15.5.1)

1. Remove the Paper Tray from the STF.
2. Remove the Front Covers (page 8-130).
3. Remove the Cover Right (page 8-131).
4. Disconnect P/J81 from the Harness Feeder Plug Assembly.
5. Disconnect P/J82 from the Harness Assembly Tray 3.
6. Disconnect P/J84 from the Drive Assembly.
7. Remove the 3 screws securing the Power Feeder Circuit board to the STF frame and remove the board.

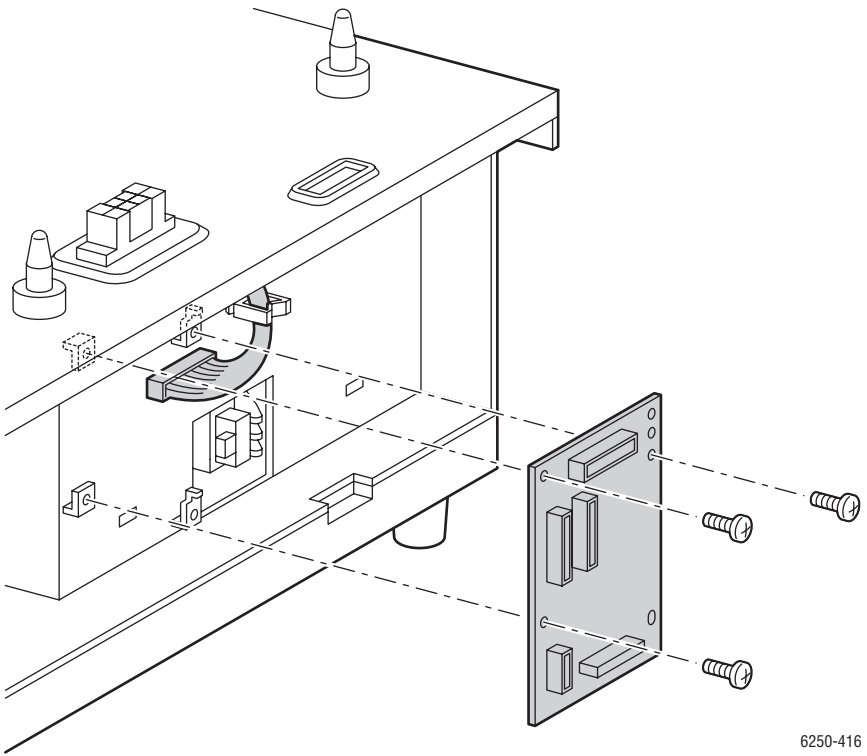

6250-416

Replacement Notes

Note

When replacing the Power Feeder Circuit Board, align the hole on the board and the two tabs on the STF Frame.

Drive Feeder Assembly (PL15.5.5)

1. Remove the Paper Tray from the STF.
2. Remove the Front Covers (page 8-130).
3. Remove the Right Cover (page 8-131).
4. Release the Tray 3 Harness Assembly (gray) from the cable restraints.
5. Disconnect P/J84.
6. Remove the 3 screws securing the Feeder Drive Assembly to the STF and remove.

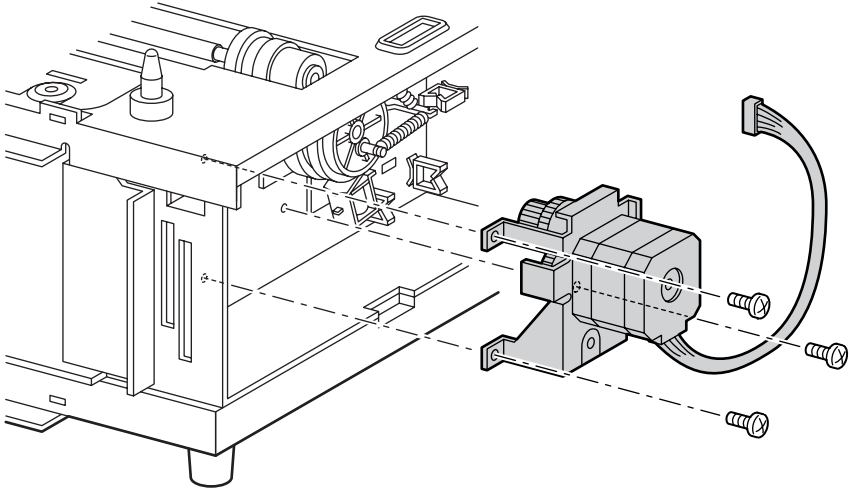

6250-414

Indicator Assembly (PL15.5.8)

1. Remove the Paper Tray from the STF.
2. Remove the Front Covers (page 8-130).
3. Remove the Right Cover (page 8-131).
4. Push down on the black bearing, on the top of the indicator shaft, lift up on the shaft and pull out of the hole in the STF frame.

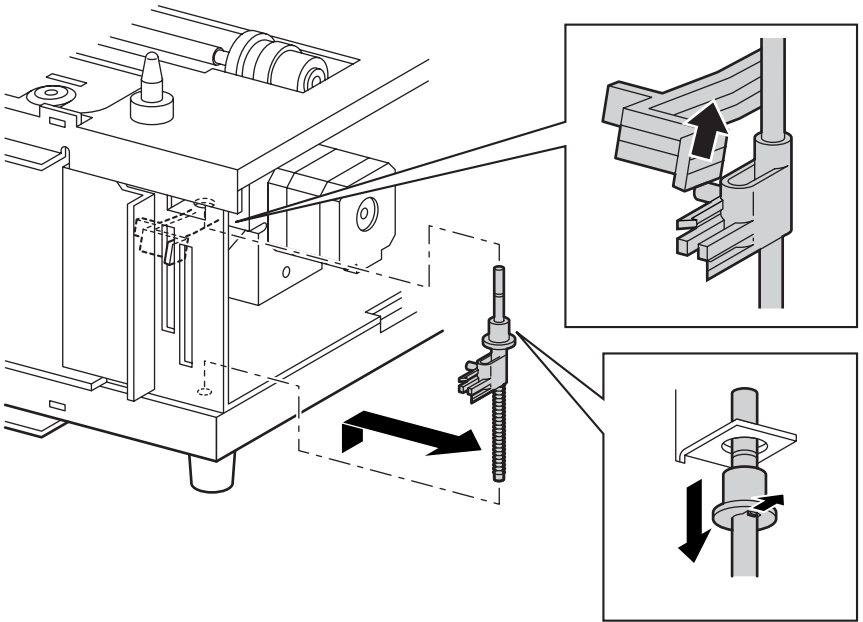

6250-412

Reassembly

Note

The Indicator Assembly has to be below the Low Paper Lever.

Right Tray Guide (PL15.3.5) and Low Paper Lever (PL 15.5.7)

Guide Assembly Paper Tray Right

1. Remove the Paper Tray from the STF.
2. Remove the Front Covers (page 8-130).
3. Remove the Right Cover (page 8-131).
4. Remove the Turn Chute Assembly (page 8-132) .
5. Remove the Feeder Drive Assembly (page 8-136).
6. Remove the Indicator Assembly (page 8-137).
7. Remove the STF Circuit Board (page 8-135).
8. Remove the 1 screw securing the Low Paper Bracket to the STF frame.
9. Remove the Bracket.

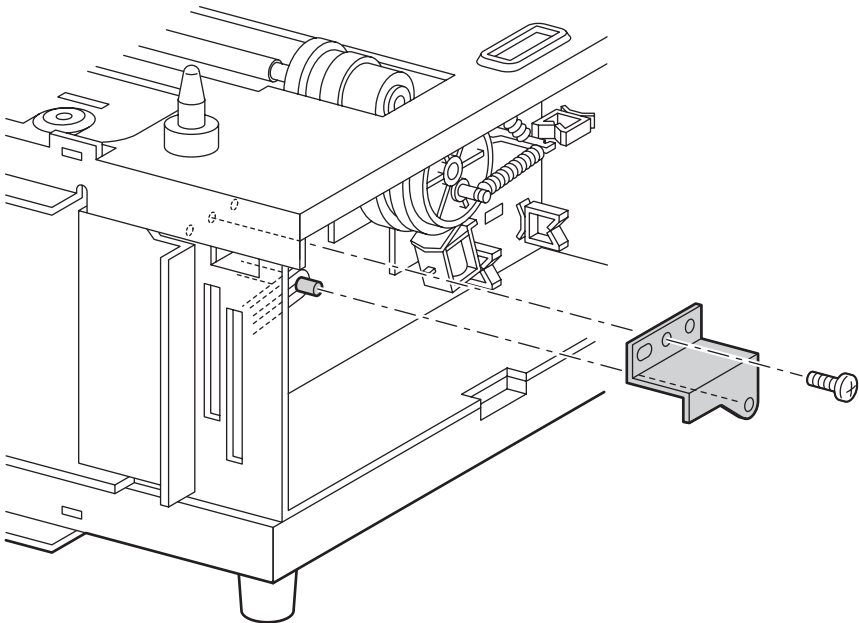

6250-415

10. Remove the 5 screws securing the Right Tray Guide to the STF frame.

11. Release the 7 tabs securing the Right Tray Guide to the STF frame.

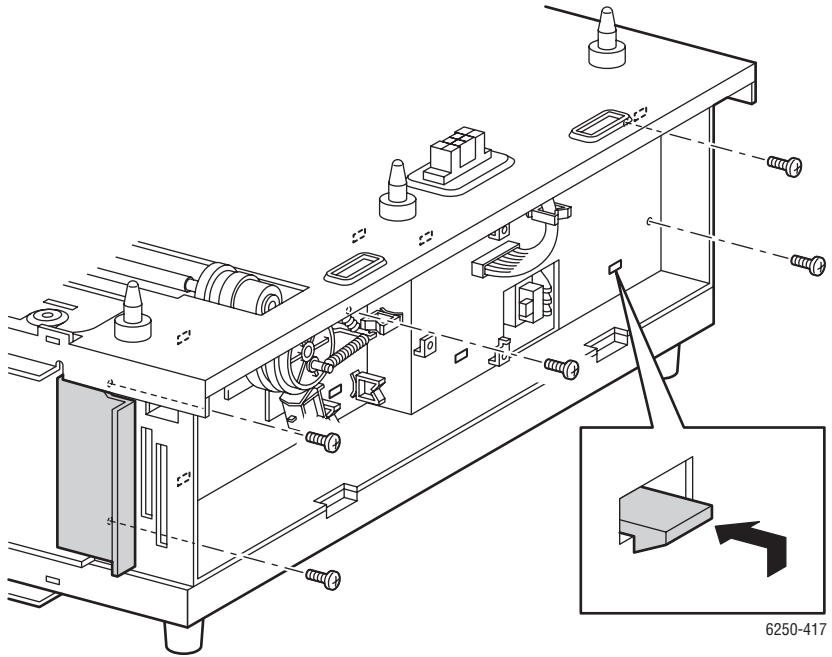

12. Carefully remove the Low Paper Lever from the slit in the Right Tray Guide.

13. Remove the Guide Assembly Right by rotating the top in..

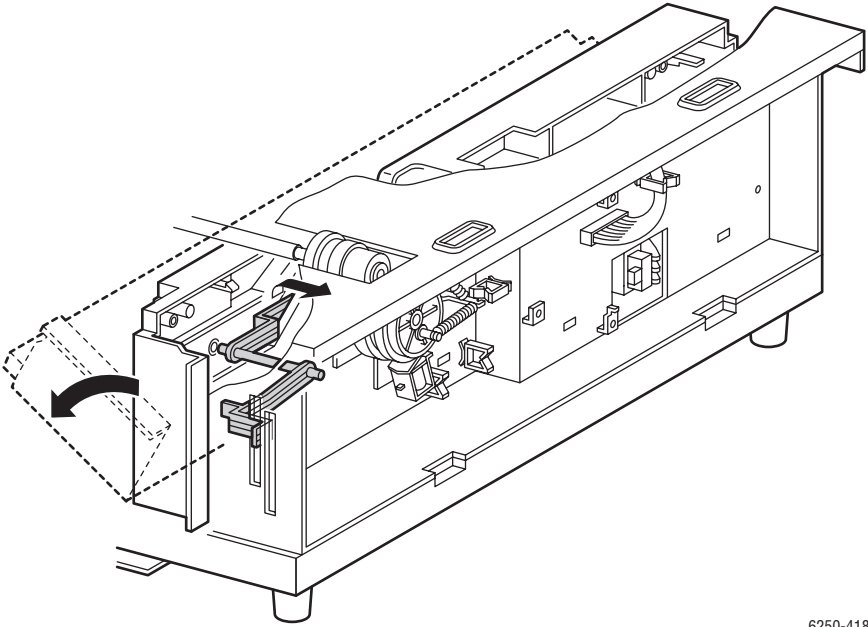

6250-418

Left Tray Guide (PL15.3.3)

1. Remove the Paper Tray from the STF.
2. Remove the Front Covers (page 8-130).
3. Remove the Left Cover (page 8-131).
4. Remove the Turn Chute Assembly (page 8-132).
5. Remove the 5 screws securing the Left Tray Guide Assembly to the STF frame.
6. Release the 6 tabs securing the Left Tray Guide Assembly to the STF frame.

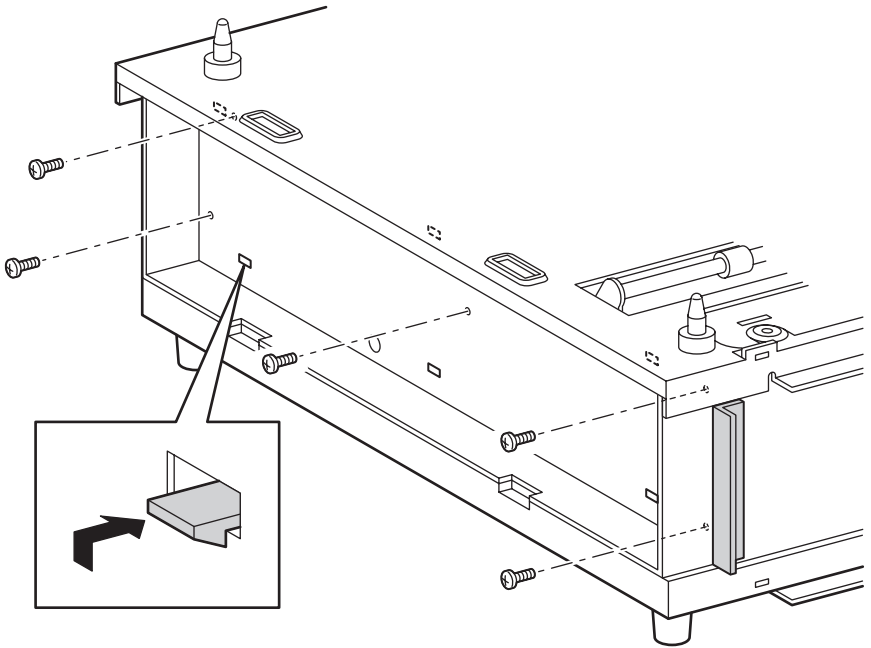

6250-419

7. Remove the Guide Assembly by rotating the top inward.

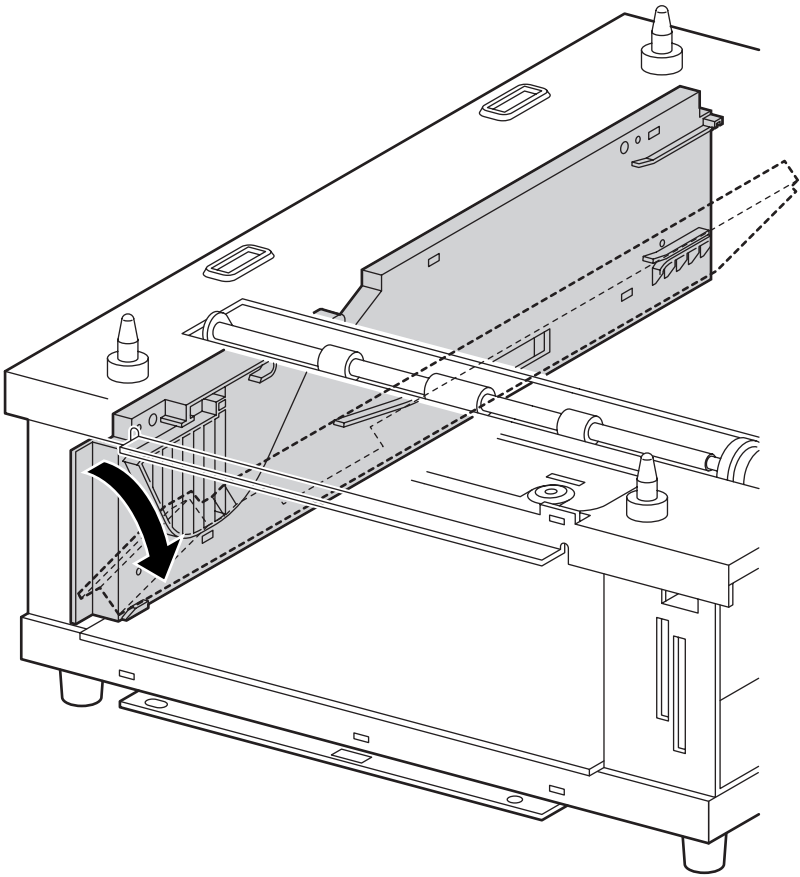

6250-420

Link Actuator (PL 15.4.6)

1. Remove the Paper Tray from the STF.
2. Remove the paper tray Rear Cover.
3. Reach in through the rear of the STF and spread the tabs of the Link Actuator apart.
4. Remove the link actuator from the bracket in the STF.
5. Remove the actuator.

Note

When replacing, position the Actuator so that the wider portion is on the right side view from the front. Replace it after passing the tip of the Link Actuator into the hole in the STF frame.

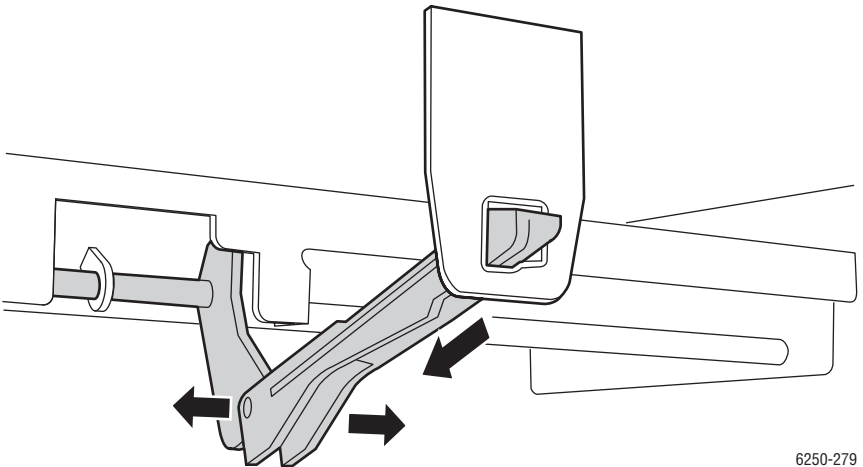

6250-279

STF Paper Pick Assembly (PL15.4.1)

1. Remove the Right and Left Tray Guide Assemblies (page 8-138) and (page 8-141).
2. Remove the Link Actuator (page 8-143).
3. Remove the 2 screws securing the Paper Pick Assembly to the right side of the STF frame.
4. Release 2 tabs on the Paper Pick Assembly from the 2 slits and window on the left side of the STF frame.
5. Disconnect P/J824, P/J8220 and P/J825.
6. Remove the Paper Pick Assembly through the window.

Note

When removing or replacing the the screws, be careful not to damage the Gear or Spring with the screwdriver. When passing the Paper Pick Assembly through the window, be careful not to damage the rubber parts.

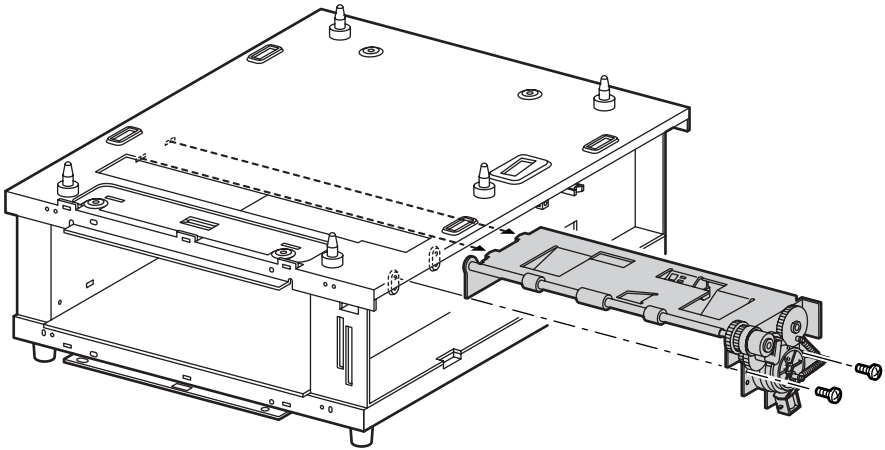

6250-421

No Paper, Low Paper Sensor (PL15.5.6)

1. Remove the Paper Tray.
2. Remove the Cover Front (page 8-130).
3. Remove the Cover Right (page 8-131).
4. Remove the Turn Chute Assembly (page 8-132).
5. Remove the Indicator Assembly (page 8-137).
6. Remove the Bracket Low Paper.
7. Remove the STF Circuit Board (page 8-135).
8. Remove the Right Tray Guide (page 8-138).
9. Release the 3 tabs securing the Sensor to the STF frame and remove the sensor.

Note

Use caution, the Sensor tabs are easily broken.

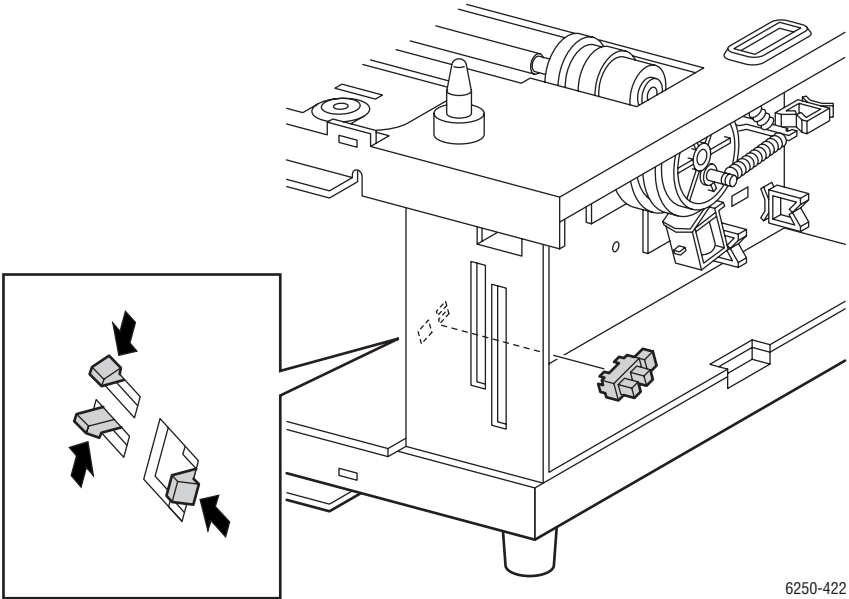

6250-422

Paper Size Switch Assembly (PL15.3.6)

1. Remove the Right Tray Guide Assembly (page 8-138).
2. Remove the 1 screw securing the Paper Size Switch to the Right Guide Assembly and remove the switch.

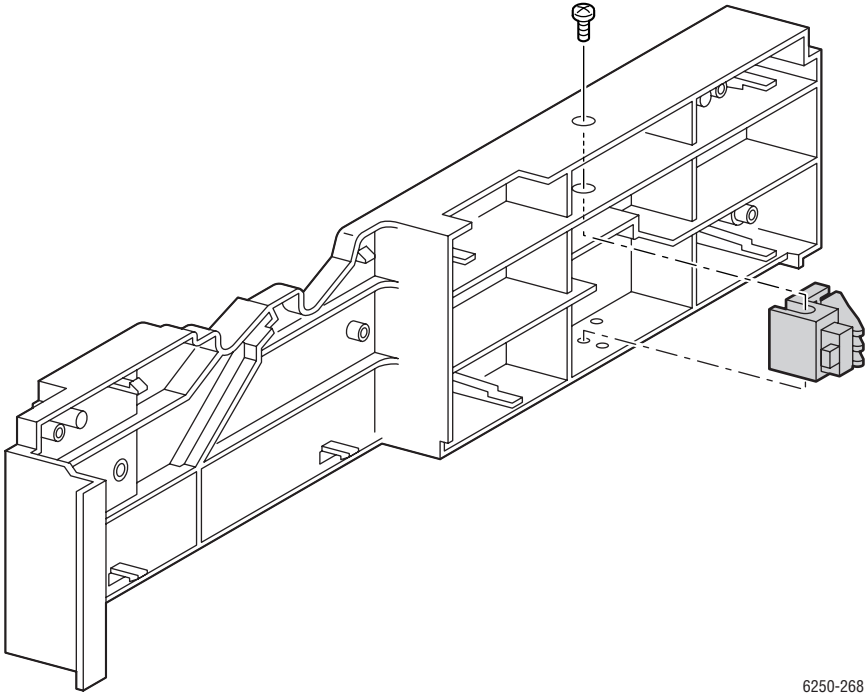

6250-268

Parts List

In this chapter...

- Serial Number Format
- Using the Parts List
- Print Engine Parts
- Harness Assemblies
- Optional High-Capacity Feeder
- Optional 500-sheet Feeder
- Xerox Supplies and Accessories

Chapter 9

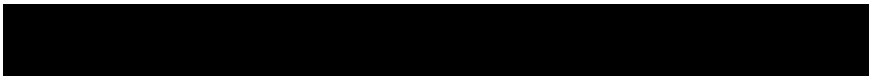

Serial Number Format

Changes to Xerox products are made to accommodate improved components as they become available. It is important when ordering parts to include the following information:

- Component's part number
- Product type or model number
- Serial number of the printer

Serial numbering. Particular fields in the serial number indicate the modification level of the printer, the date of its manufacture and the sequence number of the printer produced on that day.

The serial number is coded as follows:

- The text “S/N” followed by the serial number in the barcode.
- The barcode **does not** include a field identifier.
- The nine digit serial number is based on the following format:
PPRSSSSS

PPP = Three digit alphanumeric product code

Product	Model	Voltage	Product Code
6250	B, N, DP, DT, DX	110V	PWG
6250V	B, N, DP, DT, DX	220V	PWH

R - Single numeric revision digit. To be rolled when a major product change occurs. Code change is initiated with a change request.

SSSSS - Five digit numeric serial number.

Serial Number Example:

PWG453072:

PWG = Product code for the 110V Printer

4 = Revision level

53072 = Serial number

Using the Parts List

1. **No.:** The callout number from the exploded part diagram.
2. **Part Number:** The material part number used to order specific parts.

Note

An asterisk following the part number identifies parts that are unique to the Phaser 6250 Color Laser Printer. All other part are common with the Phaser 6200 Color Laser Printer.

3. **Qty:** This number represents the parts per printer, not the number of parts supplied in the actual part order.
4. **Name/Description:** Details the name of the part to be ordered and the number of parts supplied per order.
5. Parts identified throughout this manual are referenced **PL#.#.#**; For example, PL3.1.10 means the part is item 10 of Parts List 3.1.
6. A black triangle preceding a number followed by a parenthetical statement in an illustrated parts list means the item is a parent assembly, made up of the individual parts called out in parentheses.
7. The notation “**with X~Y**” following a part name indicates an assembly that is made up of components X through Y. For example, “1 (with 2~4)” means part 1 consists of part 2, part 3, and part 4.
8. Two asterisks (**) following a part name indicates the page contains a note about this part.
9. The notation (NS) next to a part indicates that particular part is not spared, but contained in a kit or major assembly.
10. The notation “**J1<>J2 and P2**” is attached to a wire harness. It indicates that connector Jack 1 is attached to one end of the wire harness and connector J2 is attached to the other end that is plugged into P2.

Note

Only parts showing part numbers are available for support. Parts not showing part numbers are available on the parent assembly.

Legend:

Identifier	Meaning
C	C-ring
E	E-ring
KL	K-clip
S	Screw

PL 1.1 Covers - Service Parts List

No.	Part Number	Qty	Name/Description
1.	333-4405-00*	1	Control Panel (Front Panel Display)
2.	116-1357-00*	1	Cover Assembly, Front (with 3-7)
3.		1	Cover, Front (NS, part of PL 1.1.2)
4.		1	Holder, Lever Out (NS)
5.		1	Lever Out (NS)
6.		1	Con. Amp 175694-3 (NS)
7.	116-1550-00	1	Fan, Fuser
8.	116-1074-00*	1	Cover Assembly, Top
9.	116-1359-00	1	Cover, Top Main
10.	116-1360-00*	1	Cover Assembly, Top Image Unit (with 11-19) (Door C)
11.		1	CAM I/R (NS)
12.		1	Cover, CAM (NS)
13.		1	Spring, CAM I/R (NS)
14.	116-0011-00	1	Latch, Top Right
15.		1	Handle, Top (NS)
16.		1	Shaft Latch, Top (NS)
17.		1	Spring, Handle (NS)
18.	116-1372-00*	1	Latch, Top Left
19.		1	Cover, Top Image Unit (Door C)(NS)
20.	116-0016-00	1	Cover, Rear
21.	116-0492-00	2	Stud, Top (1 per order)
22.	116-0586-00	2	Spring, Link (1 per order)
23.	116-0963-00	2	Link (1 per order)
24.	116-1373-00*	1	Cover, Side, Right
25.	116-1322-00	1	Cover Assembly, Front Right
26.		1	Cover, Tray 1 (MPT) (NS, part of Tray 1 99)
27.		1	Tray 1 Slide (NS, part of Tray 1 99)
28.	116-1375-00*	1	Assembly, Tray 1, Base
29.	116-1376-00*	1	Cover Assembly, Front Left
30.	116-1327-00	1	Cover, Side, Left
31.	116-1096-00*	1	Cover, Top Stopper

PL 1.1 Covers - Service Parts List

No.	Part Number	Qty	Name/Description
32.	116-1592-00*	1	Kit, Cover Front Retaining Clips
99	116-1377-00*	1	Tray 1, (MPT) (with 26 and 27)

PL 2.1 Universal Paper Tray

▼1(with 2~7)

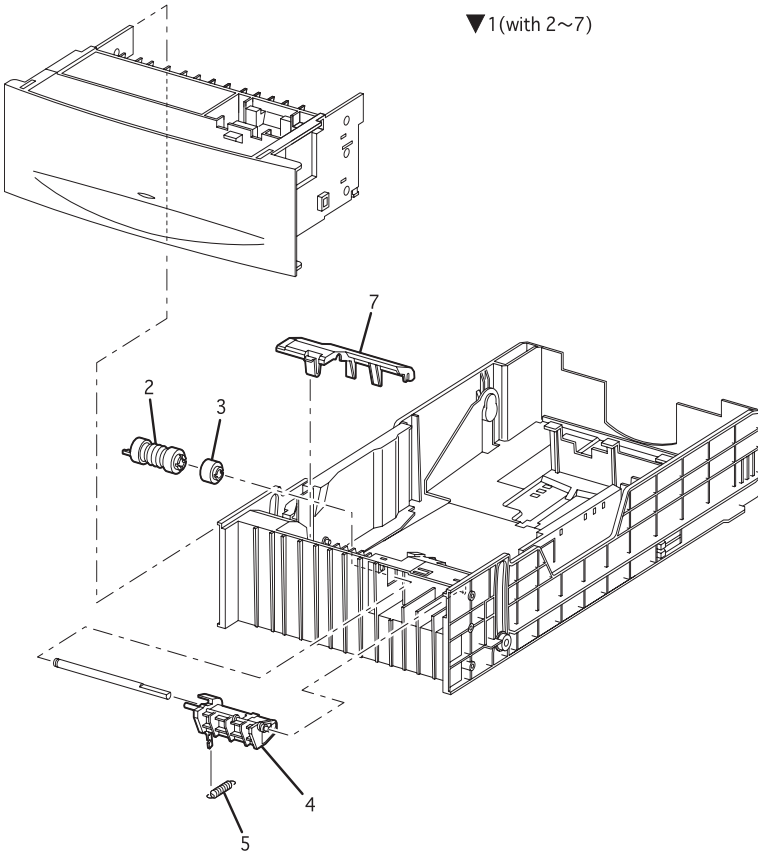

6250-287

PL 2.1 Tray, Univeral Paper - Service Parts List

ID No.	Part Number	Qty	Name/Description
1.	116-1378-00*	1	Universal Paper Tray (with 2~6)
2.	116-1331-00	2	Paper Feed Roller Kit* *(2 interchangeable rollers per order)
3.	116-1332-00	1	Assembly, Friction Clutch
4.		1	Holder, Retard (NS)
5.	116-1632-00*	1	Spring, Retard
6.			
7.	116-1490-00		Chute, Guide Cover

PL 3.1 Paper Feed I

▼99(with1~4, PL3.2 + PL3.3)

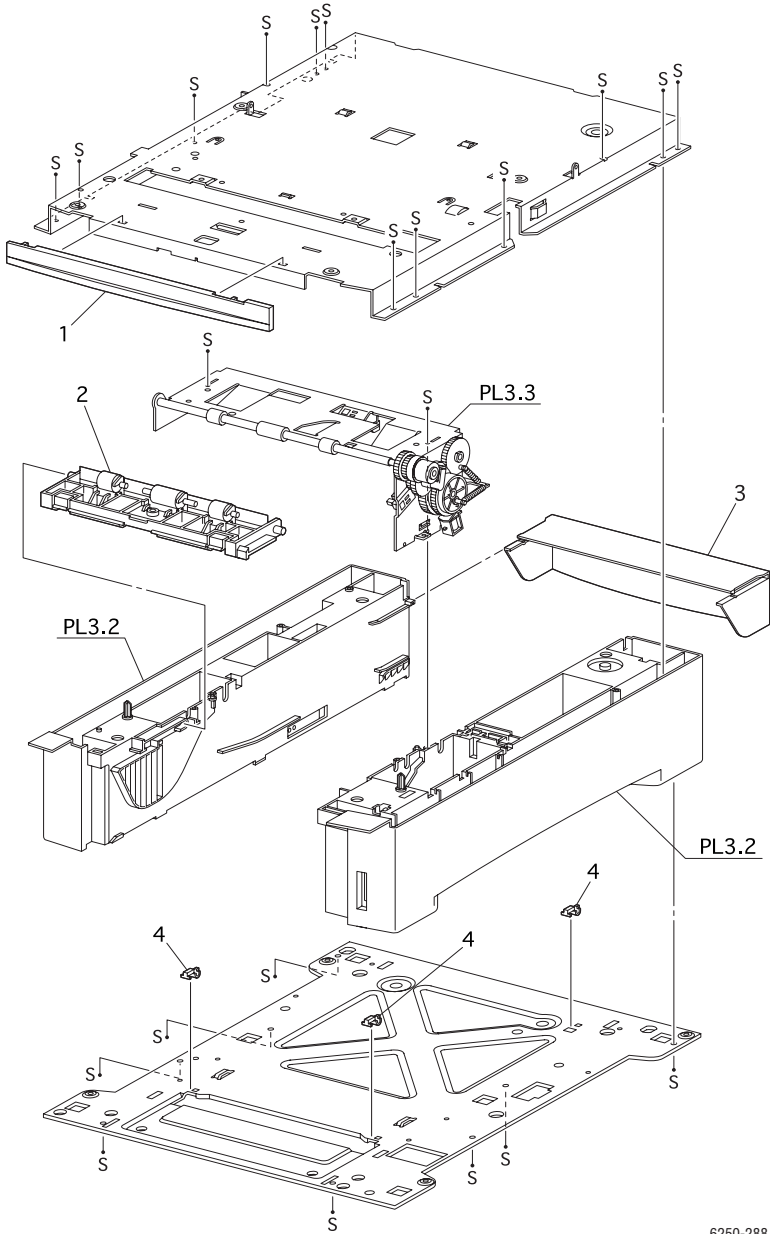

6250-288

PL 3.1 Paper Feed I - Service Parts List Table

ID No.	Part Number	Qty	Name/Description
1.	116-1335-00	1	Cover, Feeder, Front
2.	116-1336-00	1	Assembly, Turn Chute
3.	116-1491-00*	1	Cover, Paper Tray, Rear
4.	116-1338-00	3	Block (1 per order)
5.	212-0237-00	4	Long Screw (M3 x 85) Kit (2 per order)
99.	116-1631-00	1	Assembly, Feeder (with 1 - 4 & PL 3.2 & PL 3.3)

PL 3.2 Paper Feed II

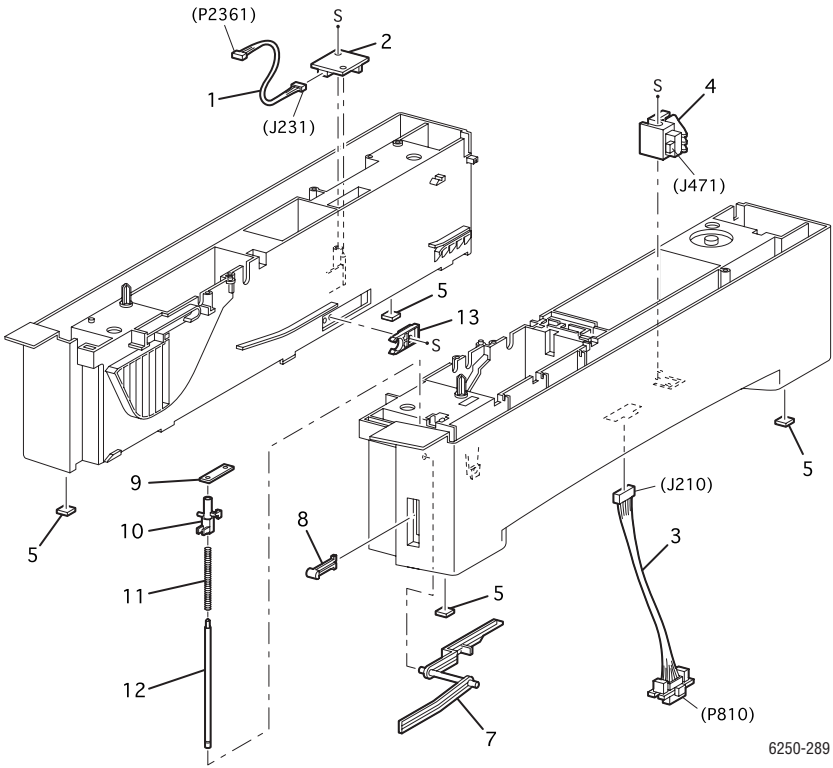

6250-289

PL 3.2 Paper Feed II - FRU Parts List Table

ID No.	Part Number	Qty	Name/Description
1.	116-1340-00	1	Assembly, Harness, Temperature/Humidity (J231~J2361)
2.	116-1341-00	1	Sensor, Temperature/Humidity
3.	116-1342-00	1	Asssembly, Harness, LTA (HCF) (J210~P810)
4.	116-1343-00	1	Assembly, Paper Size Switch
5.	116-1625-00	4	Printer Feet (4 per order)
6.	---	-	---
7.	116-1345-00	1	Lever, Low Paper
8.	116-1346-00	1	Indicator, Paper Level
9.		1	Indicator, Holder, Shaft (NS)
10.	116-1348-00	1	Indicator, Guide
11.		1	Indicator, Spring (NS)
12.		1	Indicator, Shaft (NS)
13.	116-1351-00	1	Paper Tray Stopper

PL 3.3 Paper Feed III

▼1(with 2~5, 7~23)

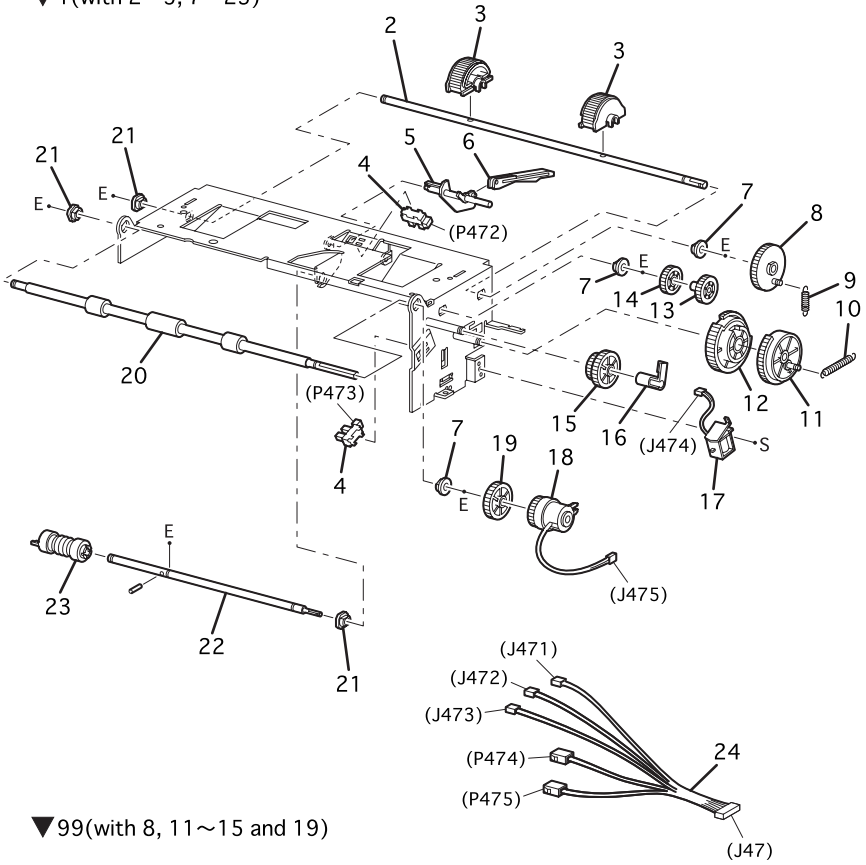

6250-290

PL 3.3 Paper Feeder III - Service Parts List

ID No.	Part Number	Qty	Name/Description
1.	116-1352-00	1	Assembly, Paper Pick (with 2~5 & 7~23)
2.		1	Shaft, Feed 1 (NS)
3.	116-1353-01	2	Paper Pick Roller Kit (2 per order)
4.	116-1354-00	1	Sensor, (No Paper, Low Paper)
5.	116-1355-00	1	Actuator, No Paper
6.	116-1356-00	1	Actuator, Link (not included with item 1)
7.		3	Bearing - Metal (NS)
8.		1	Gear, Feed 1 (NS)
9.		1	Spring, Feed 1 (NS)
10.		1	Spring, Feed H (NS)
11.		1	Gear, Feed H2 (NS part of 99)
12.		1	Gear, Feed H1 (NS part of 99)
13.		1	Gear, Feed 2 (NS part of 99)
14.		1	Gear, Idler Feed (NS part of 99)
15.		1	Gear, Idler (NS part of 99)
16.		1	Clutch Stopper (NS)
17.	116-1361-00	1	Feed Solenoid
18.	116-1362-00	1	Assembly, Clutch Turn
19.		1	Gear, Idler In (NS part of 99)
20.	116-1363-00	1	Assembly, Roll Turn
21.		3	Bearing - Black (NS)
22.		1	Shaft, Feed 2 (NS)
23.	116-1331-00	2	Paper Feed Roller Kit* *(2 interchangeable rollers per order)
24.	116-1366-00	1	Assembly, Harness, Feeder (J47-J471/J472/J473/P474/ P475) (not included with item 1)
99)	116-1367-00	1	Paper Feed Gear Kit (with 8, 11~15 and 19)

PL 4.1 Housing Assembly Retard

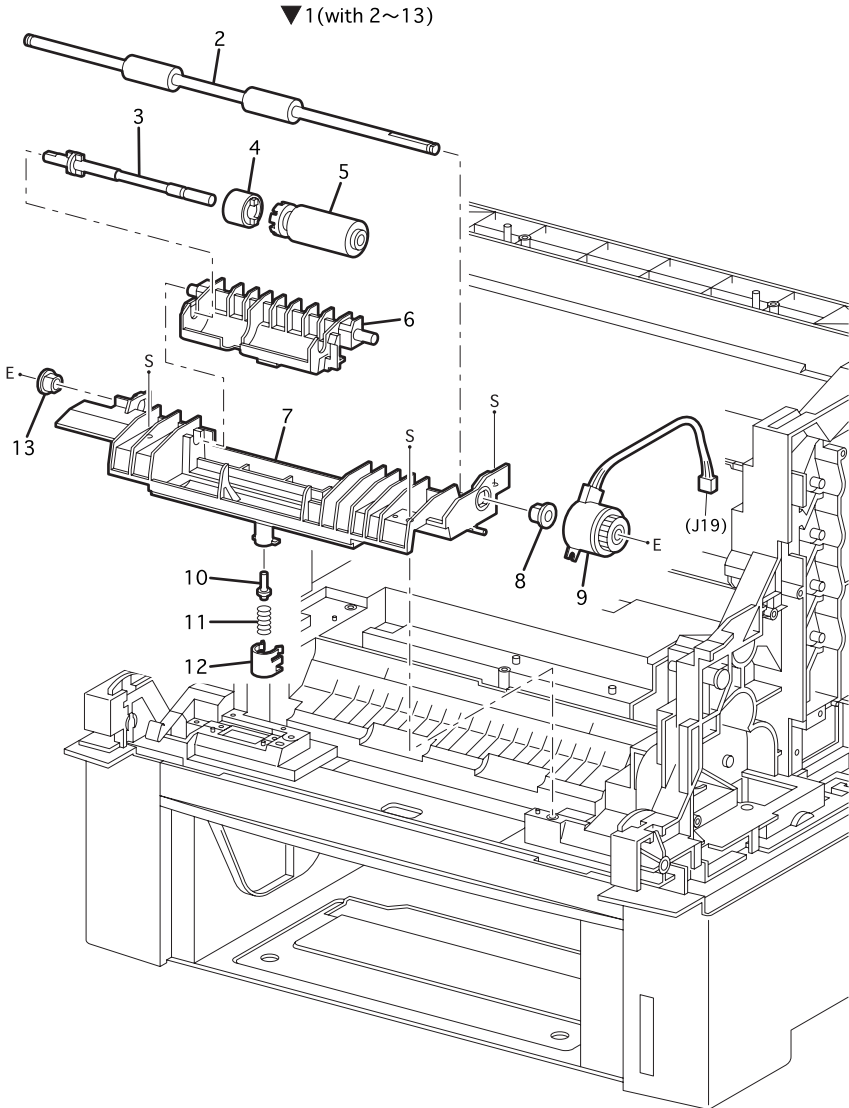

6250-291

PL 4.1 Assembly, Housing Retard - Service Parts List Table

ID No.	Part Number	Qty	Name/Description
1.	116-1492-00*	1	Assembly, Housing Retard (with 2~13)
2.		1	Roll, Turn (NS)
3.		1	Shaft, Retard (NS)
4.		1	Assembly, Friction Clutch (NS)
5.	116-1371-00	1	Assembly, Retard Roll
6.		1	Holder, Retard (NS)
7.		1	Housing, Retard (NS)
8.		1	Bearing (NS)
9.		1	Turn Clutch (NS)
10.		1	Stud, Retard (NS)
11.		1	Spring, Retard 370 (NS)
12.		1	Cap, Retard (NS)
13.		1	Bearing, Ground (NS)

PL 5.1 Chute Assembly, In - Service Parts List Table

ID No.	Part Number	Qty	Name/Description
1	116-1493-00*	1	Chute Assembly, In (with 2~30)
2	116-1381-00	1	Assembly, Wiring 2nd BTR (J5020)(Transfer Roller)
3	116-1382-00	1	Spring, 2nd BTR
4	116-1383-00	1	Shaft, BTR IN
5	116-1384-00	1	Assembly, Wire Disk (J5030)
6	116-1385-00	1	Spring, DTC
7	116-1386-00	1	Stud, 2nd BTR
8	116-1387-00	1	Spring, Holder BTR
9	116-1575-00*	1	Assembly, Harness Fuser (FSR 4) (J232, J233, J162, J138, J145, J2362)
10	116-1390-00	1	Assembly, Harness CTD (ADC)
11	116-1391-00	1	Assembly, Sensor CTD (ADC)
12	116-1392-00	1	Spring, ADC
13	116-1393-00	1	Sensor, Toner Full
14	116-1394-00	1	Assembly, Harness Toner Full SNS
15	116-1395-00	1	Spring, IDT
16	116-1396-00	1	Stud, IDT
17	116-1397-00	1	Holder, IDT
18	116-1588-00*	1	Assembly, Drive Fuser
19	116-1399-00	1	Spring, BTR
20	116-1400-00	1	Wire Assembly, FSR Earth GRND
21	116-1401-00	1	Right Latch
22	116-1402-00	1	Spring, Latch
23		1	Shaft, Latch (NS)
24	116-1403-00	1	Plate, In T/R
25	116-1404-00	2	Roll, Pinch Turn (1 per order)
26	116-1405-00	2	Spring, Pinch Turn (1 per order)
27	116-1406-00	2	Roll, Pinch Dup (1 per order)
28	116-1407-00	1	Spring, Pinch Dup
29	116-1408-00	1	Chute, In
30	116-1409-00	1	Left Latch

PL 6.1 Chute Assembly Out

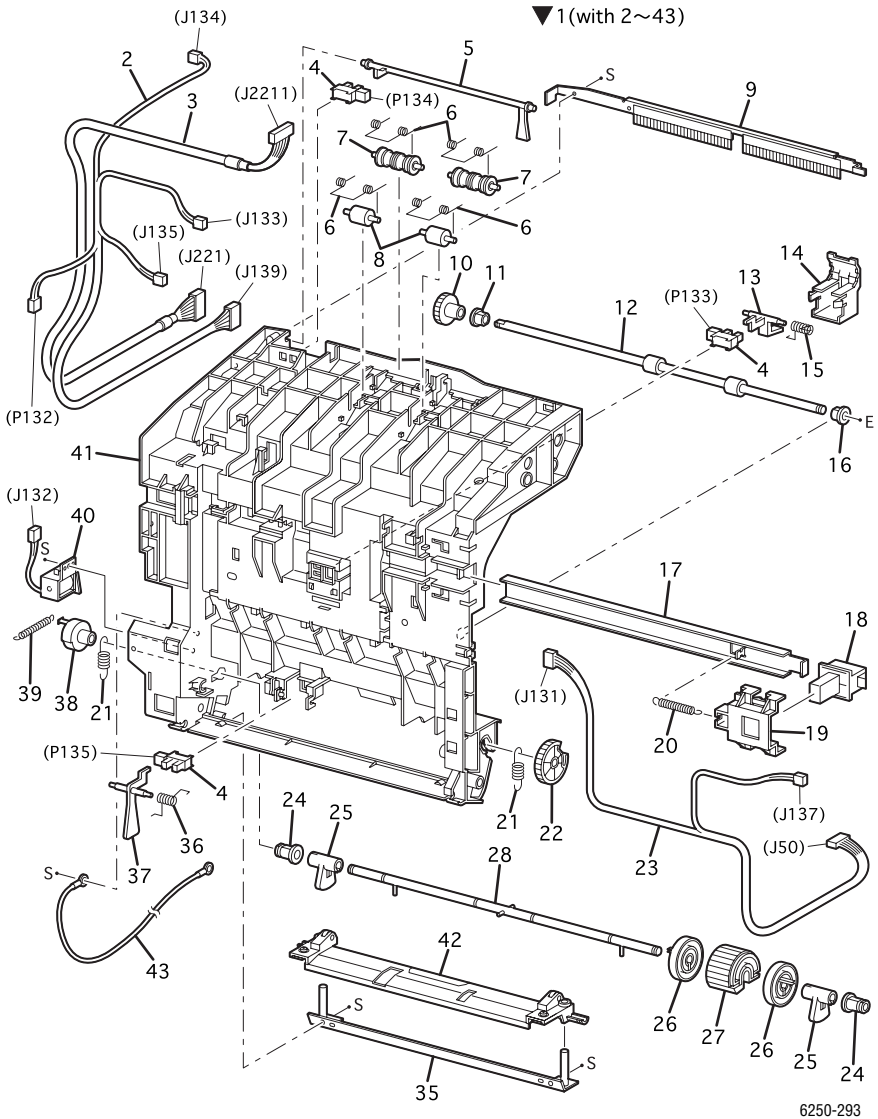

PL 6.1 Chute Assembly, Out - Service Parts List Table

ID No	Part Number	Qty	Name/Description
1.	116-1591-00*	1	Assembly, Chute Out (with 2~43 & PL 7.1)
2.	116-1411-00	1	Assembly, Harness, Front 2
3.	116-1593-00*	1	Assembly, Harness, Front Panel
4.	116-1413-00	3	Sensor, (Dup Jam, Full Stack, MSI No Paper) (1 per order)
5.	116-1414-00	1	Actuator, Output Tray Full (Full Stack)
6.	116-1634-00*	4	Spring, Pinch Exit (1 per order)
7.	116-1416-00	2	Roll, Pinch Exit (1 per order)
8.	116-1417-00	2	Roll, Pinch (1 per order)
9.	116-1418-00	1	Eliminator Assembly
10.	116-1419-00	1	Gear 30
11.		1	Bearing Ground (NS)
12.	116-1420-00	1	Roll, Dup (Duplex)
13.	116-1421-00	1	Actuator, Duplex
14.	116-1422-00	1	Actuator, Cover
15.	116-1423-00	1	Spring, Sensor Dup (Duplex)
16.		1	Bearing (NS)
17.		1	Latch, Plate (NS)
18.		1	Latch, Out (NS)
19.		1	Latch, Holder (NS)
20.	116-1425-00	1	Latch, Spring Out
21.	116-1426-00	2	Spring, N/F MPT 250GF (1 per order)
22.	116-1427-00	1	Gear, MPT
23.	116-1594-00*	1	Assembly, Harness Duplex
24.		2	Bearing, MPT (NS)
25.	116-1430-00	2	CAM, MPT (1 per order)
26.	116-1431-00	2	Core, Roll, MPT (1 per order)
27.	116-1432-00	1	Assembly, Feed Roll
28.		1	Shaft MPT (NS)
29.			
30.			
31.			

PL 6.1 Chute Assembly, Out - Service Parts List Table

ID No	Part Number	Qty	Name/Description
32.			
33.			
34.			
35.	116-1433-00	1	Plate, Out MPT
36.	116-1434-00	1	Sensor, Spring MPT
37.	116-1435-00	1	Actuator, MPT
38.	116-1436-00	1	Solenoid Stopper
39.	116-1437-00	1	Solenoid, Spring
40.	116-1438-00	1	Feed Solenoid, MPT
41.		1	Chute, Out (NS)
42.	116-1439-00	1	Assembly, Bottom Plate, MPT
43.	116-1440-00	1	Assembly, Wire, Earth GRND

(This Page Intentionally Left Blank)

PL 7.1 Chute Assembly Exit

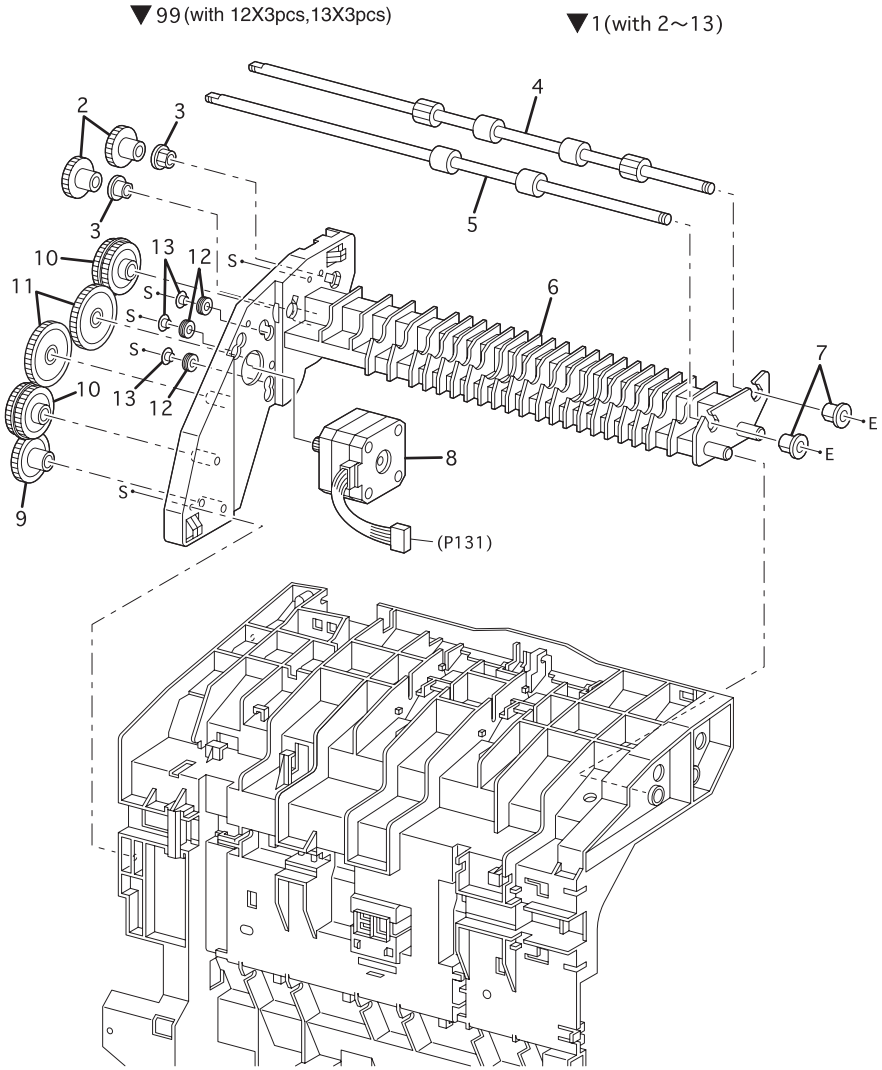

6250-294

PL 7.1 Chute Assembly, Exit - Service Parts List Table

ID No.	Part Number	Qty	Name/Description
1.	116-1595-00*	1	Chute Assembly, Exit (with 2~13)
2.		2	Gear Roll (NS)
3.		2	Bearing Earth (NS)
4.		1	Roll, Exit (NS)
5.		1	Roll, Mid (NS)
6.		1	Chute, Exit Lower (NS)
7.		2	Bearing (NS)
8.		1	Assembly, Duplex Motor (NS)
9.		1	Gear, 42 (NS)
10.		2	Gear, 40/42 (NS)
11.		2	Gear, 48 (NS)
12.		3	Grommet (NS, part of PL 7.1.99)
13.		3	Sleeve (NS, part of PL 7.1.99)
99.	116-1596-00*	1	Kit, Bushing (with 12, qty 3, 13 qty 3)

PL 8.1 Transfer Roller & Fuser Assembly (RMIs)

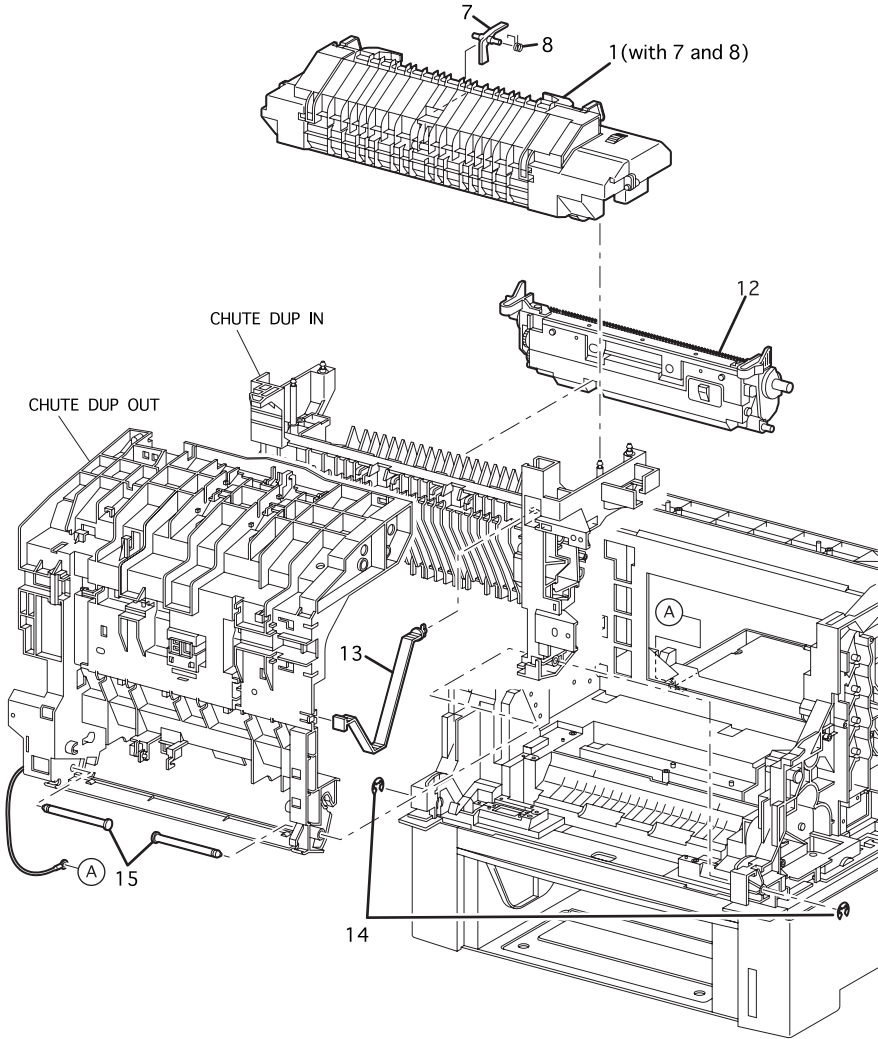

6250-295

PL 8.1 Transfer Roller and Fuser - Service Parts List Table

ID No.	Part Number	Qty	Name/Description
1.			
1a	115R00029*	1	110 V Fuser, Phaser 6250 (with 7 and 8)
1b	115R00030*	1	220 V Fuser, Phaser 6250 (with 7 and 8)
2.	---		---
3.	---		---
4.	---		---
5.	---		---
6.	---		---
7.	116-1447-00	1	Actuator, Exit
8.	116-1448-00	1	Actuator, Spring
9.	---		---
10.	---		---
11.	---		---
12.	108R00592	1	Transfer Roller, (BTR)
13.	116-1449-00	1	Strap
14.	116-1528-00	2	E-Ring (part of E-Ring Kit)
15.	116-1450-00	2	Shaft, Pivot (1 per order)

PL 9.1 Xerographics

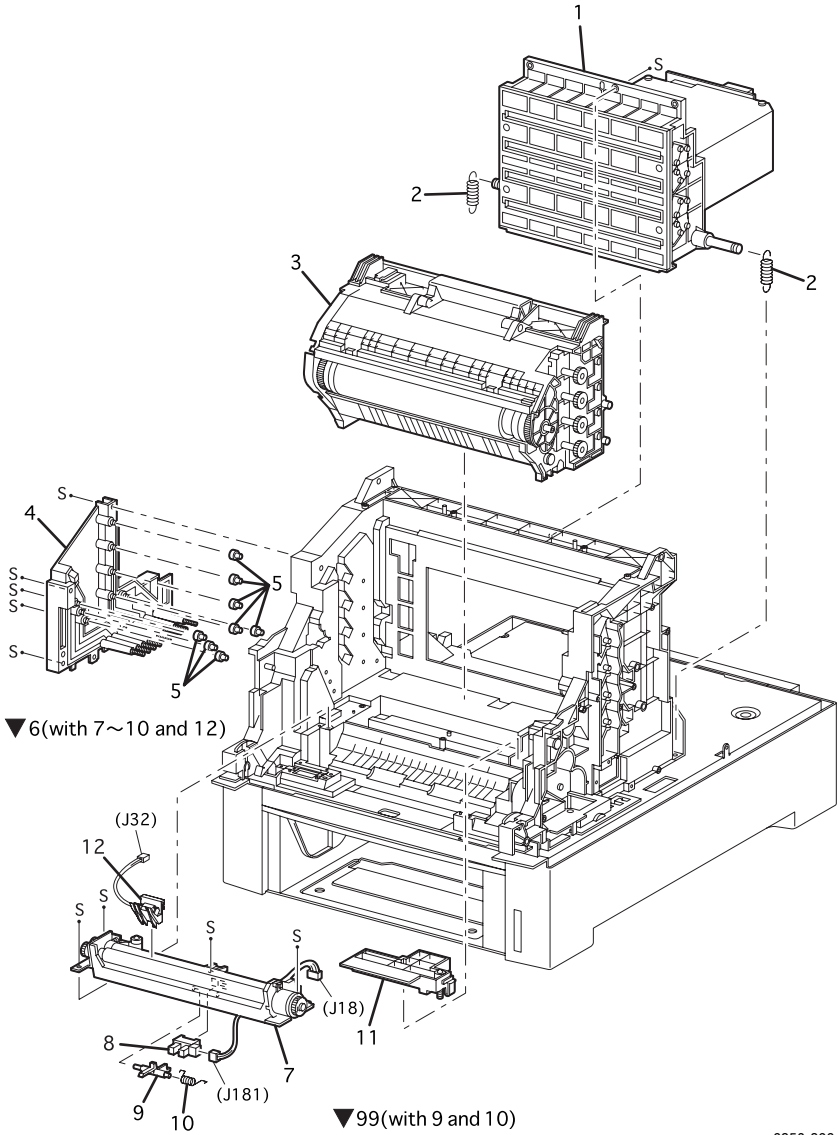

6250-296

PL 9.1 Xerographics - Service Parts List Table

ID No.	Part Number	Qty	Name/Description
1.	116-1597-00*	1	Laser Unit
2.	116-1452-00	2	Spring, ROS (1 per order)
3.	108R00591*	1	Imaging Unit, Phaser 6250
4.	116-1453-00	1	Bias Housing Assembly
5.	116-1454-00	8	Plunger, Stud (Biasing Buttons) (1 per order)
6.	116-1598-00*	1	Assembly, Chute Registration (with 7~10 and 12)
7.		1	Registration Clutch (NS)
8.	116-1413-00	1	Sensor, Registration
9.	116-1456-00	1	Actuator, Registration
10.	116-1457-00	1	Actuator Spring, Registration
11.	116-1458-00	1	Assembly, Housing, Electrical
12.	116-1459-00	1	OHP Sensor (with Harness) Kit
99.	116-1627-00	1	Kit, Registration Sensor Actuator and Spring

PL 10.1 Toner Cartridge Holder Unit Assemblies - Service Parts List

ID No.	Part Number	Qty	Name/Description
1.	116-1599-00*	1	Holder, Toner Cartridge Assembly, Yellow
2.	116-1600-00*	1	Holder, Toner Cartridge Assembly, Magenta
3.	116-1601-00*	1	Holder, Toner Cartridge Assembly, Cyan
4.	116-1602-00*	1	Holder, Toner Cartridge Assembly, Black
5.	116-1603-00*	1	Sensor, No Toner
6.	116-1604-00*	1	Switch Bracket, Toner CTG-IN
7.	106R00670* 106R00674*	1 1	Yellow Toner Cartridge, Standard-Capacity Yellow Toner Cartridge, High-Capacity
8.	106R00669* 106R00673*	1 1	Magenta Toner Cartridge, Standard-Capacity Magenta Toner Cartridge, High-Capacity
9.	106R00668* 106R00672*	1 1	Cyan Toner Cartridge, Standard-Capacity Cyan Toner Cartridge, High-Capacity
10.	106R00671* 106R00675*	1 1	Black Toner Cartridge, Standard-Capacity Black Toner Cartridge, High-Capacity
11.	116-1606-00*	1	Harness Assy, TNR4 (J51-J511/J432/J512/J513/J514/ J701/J703/J704/J342)
12.	116-1467-00	1	Assembly , Harness CRUM (J71-J710)
13.	116-1633-00*	1	Assembly, Plate Dispenser
14.	116-1468-00	1	**Circuit Board, EEPROM
15.	116-1469-00	1	Sub-High-Voltage Power Supply
16.		1	HSG Base, CRUM (NS, part of item 21)
17.		1	HSG Assy, Coil Reader (NS, part of item 21)
18.		1	Circuit Board, CRUM Reader (NS, part of item 21)
19.		1	Harness Assy, RF1D2 (J341~J3411)(NS, part of item 21)
20.		1	Cover, CRUM Holder (NS, part of item 21)
21.	116-1607-00*	1	Box Assy, CRUM Reader (with 16 ~ 20)
22.	116-1605-00*	1	Actuator, Toner CTG-IN
23.	116-1630-00	1	Kit, Rack V (Gear, Rack)

Note

** When a new EEPROM Board is installed in the printer, the CRUM data written to the EEPROM makes it unique to that printer. The EEPROM board cannot be re-used in another printer.

PL 11.1 Frame and Drive Assemblies

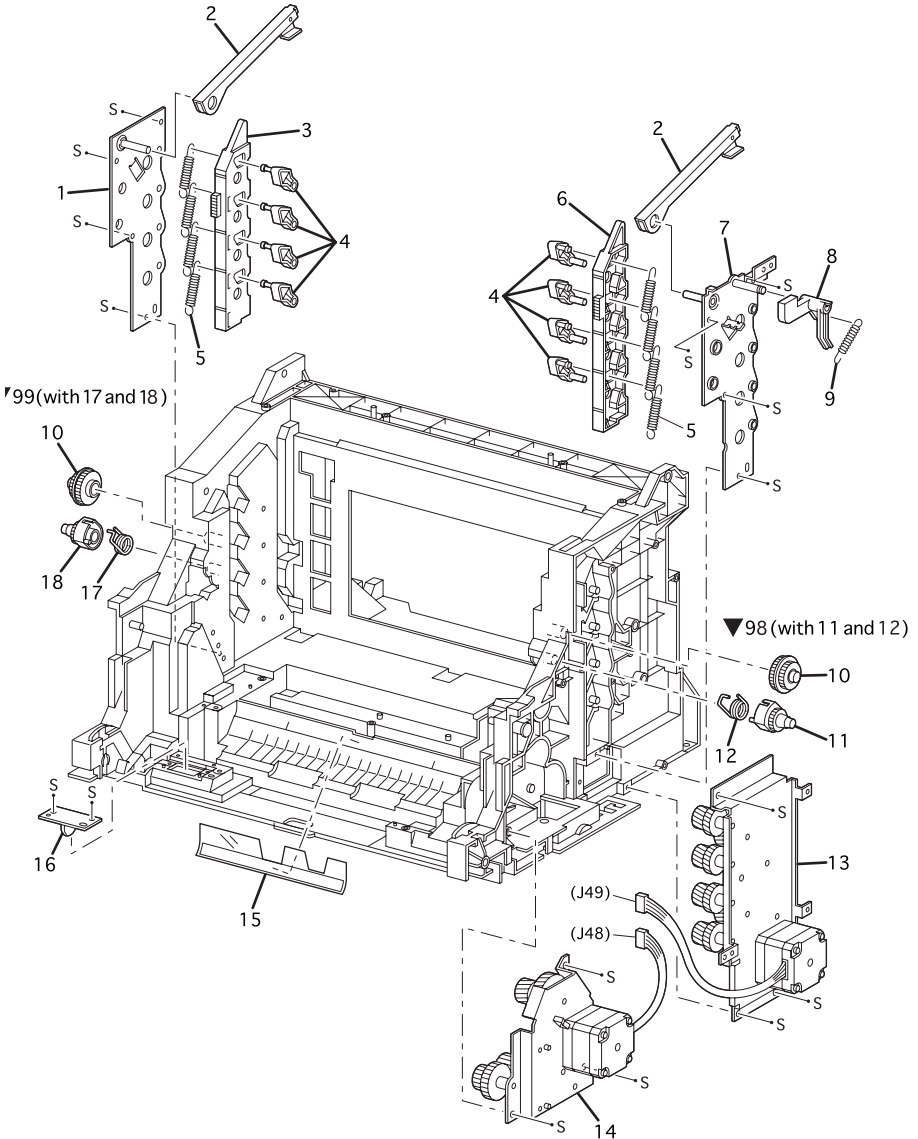

6250-297

PL 11.1 Frame and Drive Assemblies - Service Parts List Table

ID No.	Part Number	Qty	Name/Description
1.		1	Lever, Plate Left (NS)
2.	116-1471-00	2	Lever, Bracket (1 per order)
3.	116-1472-00	1	Lever, Link , Left
4.	116-1473-00	8	Lever, Drum (1 per order)
5.	116-1474-00	8	Lever, Spring (1 per order)
6.	116-1475-00	1	Link Lever, Right
7.		1	Lever, Plate Right (NS)
8.	116-1476-00	1	Actuator, I/L
9.	116-1477-00	1	Spring, I/L
10.	116-1478-00	2	Press, Gear IDL (1 per order)
11.	116-1479-00	1	Press, Gear Right
12.	116-1480-00	1	Spring, IDT Right
13.	116-1608-00*	1	Assembly, Developer Drive
14.	116-1609-00*	1	Assembly, Main Drive
15.	116-1483-00	1	Registration, Film
16.	116-1484-00	1	Circuit Board, Earth GRND (Ground)
17.	116-1485-00	1	Spring, IDT Left
18.	116-1486-00	1	Press, Gear, Left
98.	116-1610-00	1	Gear Assy, Press R (with 11 and 12)
99.	116-1611-00	1	Gear Assy, Press L (with 17 and 18)

PL 12.1 Electrical

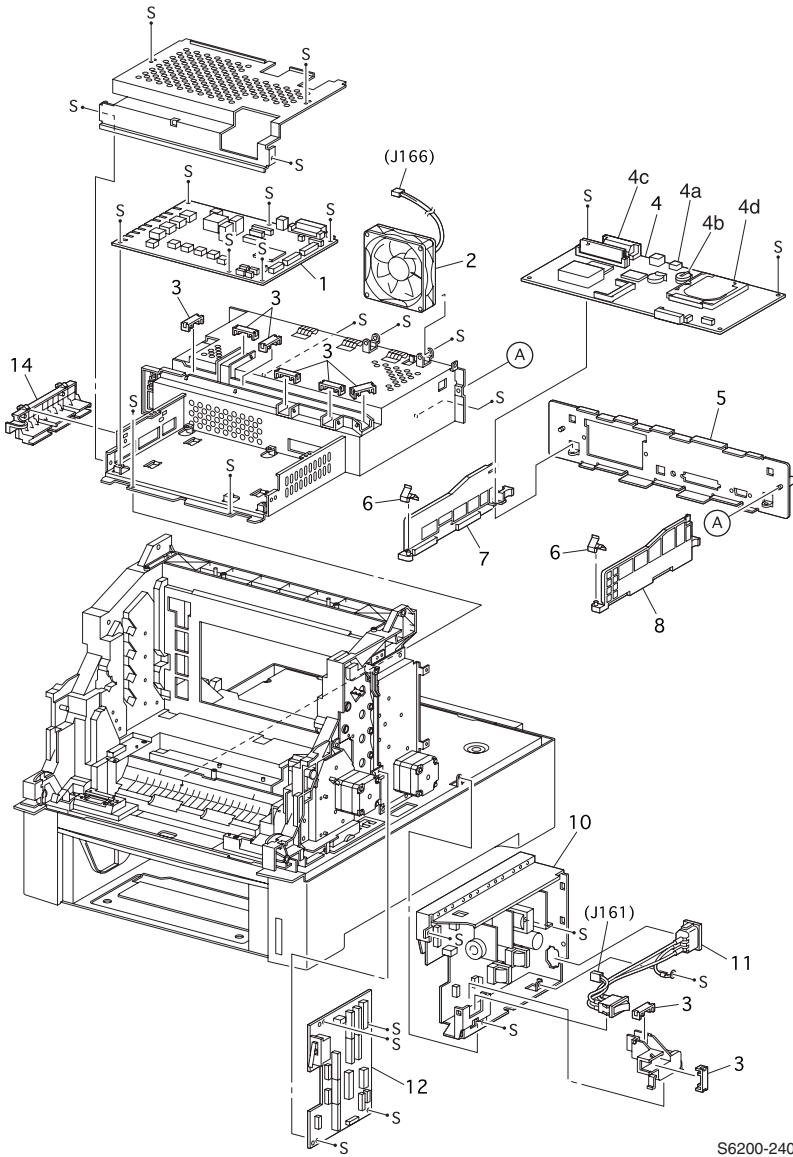

S6200-240

PL 12.1 Electrical - Service Parts List Table

ID No.	Part Number	Qty	Name/Description
1	116-1612-00*	1	Circuit Board, Engine Control
2	116-1488-00	1	Rear Fan
3	116-1489-00	2	Harness, Clamp Guide (1 per order)
4	650-4271-01*	1	Image Processor Board, no configuration chip, no memory, no NVRAM, no Hard Drive
4a	163-1459-00		IC, Memory NVRAM
4b	163-1500-00		Configuration Chip = "i" button
	163-1501-00		IC, Base Configuration Chip
	163-1502-00		IC, Network Configuration Upgrade Chip
4c			Memory
	156-4838-00		64 MB, 8M x 64, PC133; Memory DIMM
	156-4837-00		128 MB, 16M x 64, PC133; Memory DIMM
	156-4663-00		256 MB, 32M x 64, PC133; Memory DIMM
4d	650-4281-00*		Internal Hard Drive, Phaser 6250 Service Part
5		1	Plate, Rear, Image Processor Board (NS)
6		2	Spring, Ground, Image Processor Board (NS)
7		1	Guide Right - Engine Control Board (NS)
8		1	Guide Left - Engine Control Board (NS)
9	---		---
10a	116-1613-00*	1	Low-Voltage Power Supply 110 V
10b	116-1614-00*	1	Low-Voltage Power Supply 220 V
11	116-1496-00	1	Assembly, Harness, AC Switch
12	116-1615-00*	1	Circuit Board, Motor Driver
13	---		---
14	116-1498-00	1	Housing Assembly Contact

PL 13.1 - Harness Assemblies - Service Parts List Table

ID No.	Part Number	Qty	Name/Description
1.	116-1616-00*	1	Assembly, Harness, LVNC (J165-61)
2.	116-1500-00	1	Assembly, Harness, DRV 1 (J11-J41)
3.	116-1617-00*	1	Assembly, Harness, DRV 2 (J12-J42)
4.	116-1502-00	1	Assembly, Harness, LVRPG (J164-311)
5.	116-1503-00	1	Assembly, Harness, ROSKA (J15-J151)
6.	116-1504-00	1	Assembly, Harness, 24 V (J60-J163)
7.	116-1505-00	1	Assembly, Harness, FRONT 1A (J13-P138/P139/P1361/J5011)
8.	116-1506-00	1	Assembly, Harness, OPF MAIN (J121-P210)
9.	116-1205-00	1	Assembly, Harness, OPEPANE OPA (J22-J168/P221)
10.	116-1508-00	1	Assembly, Harness, EEPROM (J140-P71/J144/P141)
11.			
12.	116-1618-00*	1	Assembly, Harness, TMPNCS (J24-J2361/P2362)
13.	116-1620-00*	1	Assembly, Harness, RFID (J34-P3411)
14.			

Optional High-Capacity Feeder

PL 14.1 Paper Trays 3 & 4

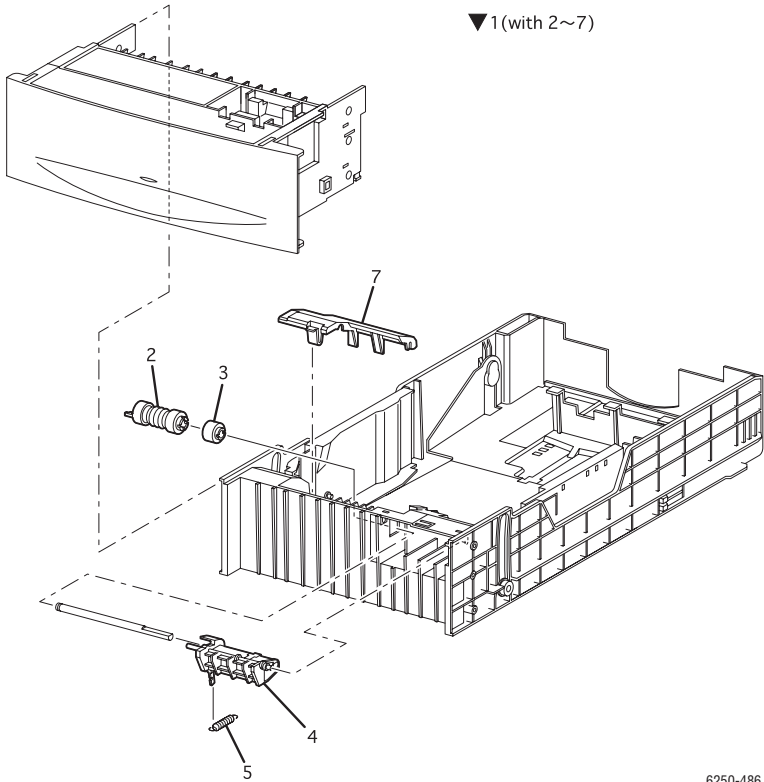

6250-486

PL 14.1 Tray 3 & 4, Universal Paper - Service Parts List Table

ID No.	Part Number	Qty	Name/Description
1.	116-1378-00*	1	Universal Paper Tray (with 2~6)
2.	116-1331-00	2	Paper Feed Roller Kit** **(2 interchangeable rollers per order)
3.	116-1332-00	1	Assembly, Friction Clutch
4.		1	Holder, Retard (NS)
5.	116-1632-00*	1	Spring, Retard
6.			
7.	116-1490-00		Chute Guide Cover

PL 14.2 High-Capacity Feeder Covers

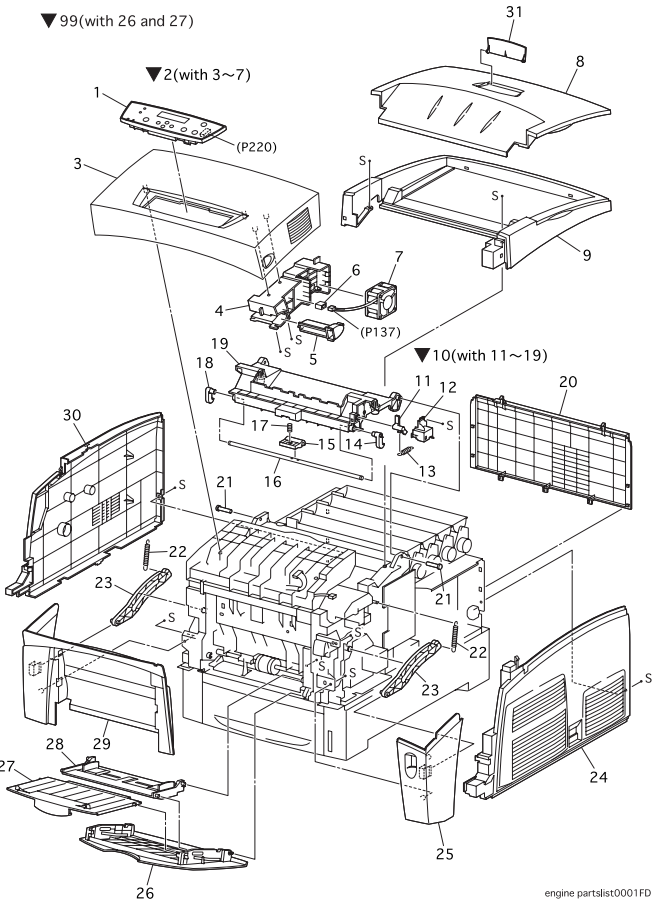

PL 14.2 High-Capacity Feeder Covers- Service Parts List Table

ID No.	Part Number	Qty	Name/Description
1.	116-1510-00	1	Cover, Left
2.			
3.	116-1511-00	1	Cover, Right
4.	116-1512-00	3	Cover, Front (1 per order)
5.	116-0009-00	2	Casters, Locking (1 per order)
6.	116-0008-00	2	Casters, Non-Locking (1 per order)
7.	116-1514-00	2	Indicator, Paper (1per order)
8.		2	Guide Caster (NS)

PL 14.3 High-Capacity Feeder Guides and Turn Chute Assembly

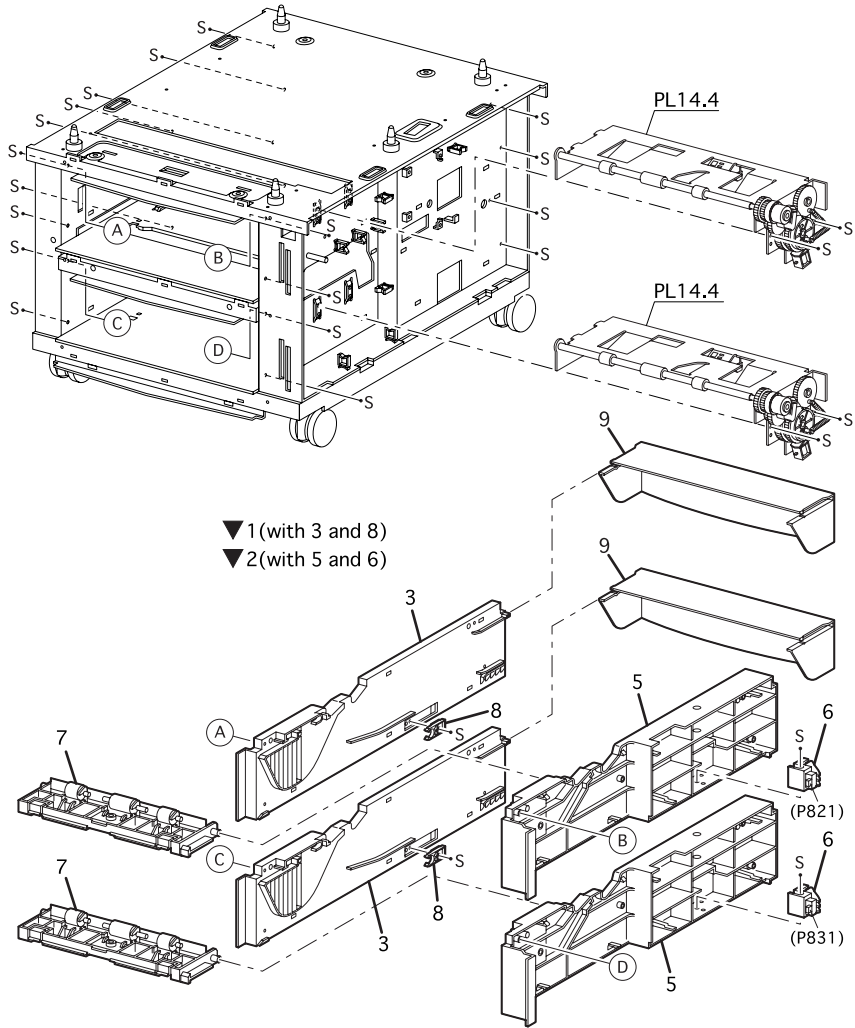

PL 14.3 High-Capacity Feeder Guides and Chute - Service Parts List Table

ID No.	Part Number	Qty	Name/Description
1.			Guide Assembly, Left (with 3 and 8) (NS)
2.			Guide Assembly, Right (with 5 and 6) (NS)
3.	116-1515-00	2	Guide, Tray Left (1 per Tray)
4.			
5.	116-1516-00	2	Guide, Tray Right (1 per Tray)
6.	116-1343-00	2	Assembly, Paper Size Switch (1 per Tray)
7.	116-1336-00	2	Assembly, Turn Chute (1 per Tray)
8.	116-1351-00	2	Paper Tray Stopper(1 per Tray)
9.		2	Cover, Rear (1 per Tray))

PL 14.4 Paper Pick Assembly Trays 3 & 4

▼ 1 (with 2~5, 7~23)

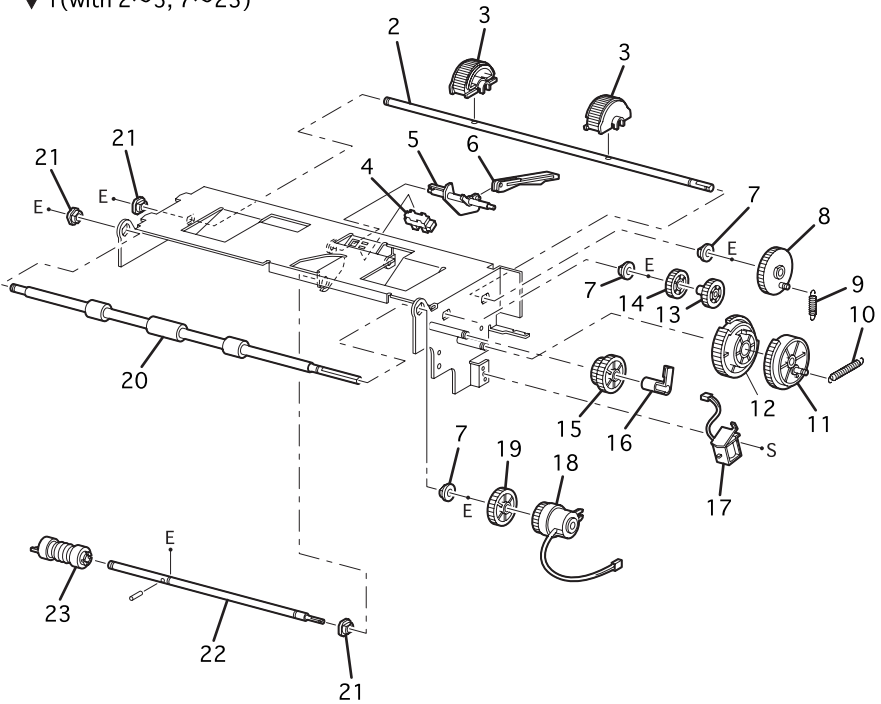

▼ 99 (with 8, 11~15 and 19)

6250-484

PL 14.4 Paper Pick Assembly Trays 3 & 4 - Service Parts List Table

ID No.	Part Number	Qty	Name/Description
1.	116-1517-00	1	Paper Pick Assembly, LTA (with 2~5, 7~23)
2.		1	Shaft, Feed 1 (NS)
3.	116-1353-01	2	Paper Pick Roller Kit (2 per order)
4.	116-1354-00	1	Sensor, No Paper, Low Paper
5.	116-1355-00	1	Actuator, No Paper
6.	116-1356-00	1	Actuator, Link (Not included with item 1)
7.		3	Bearing - Metal (NS)
8.		1	Gear, Feed 1 (NS)
9.		1	Spring, Feed 1 (NS)
10.		1	Spring, Feed H (NS)
11.		1	Gear, Feed H2 (NS part of 99)
12.		1	Gear, Feed H1 (NS part of 99)
13.		1	Gear, Feed 2 (NS part of 99)
14.		1	Gear, Idler Feed (NS part of 99)
15.		1	Gear, Idler (NS part of 99)
16.		1	Clutch Stopper (NS)
17.	116-1361-00	1	Feed Solenoid,
18.	116-1362-00	1	Assembly, Turn Clutch
19.		1	Gear, Idler In (NS part of 99)
20.	116-1363-00	1	Assembly, Roll Turn
21.		2	Bearing, Black (NS)
22.		1	Shaft, Feed 2 (NS)
23.	116-1331-00	2	Paper Feed Roller Kit** **(2 interchangeable rollers per order)
99.	116-1367-00	1	Paper Feed Gear Kit (with 8, 11~15 and 19)

PL 14.5 High-Capacity Feeder Harness, Board and Motor

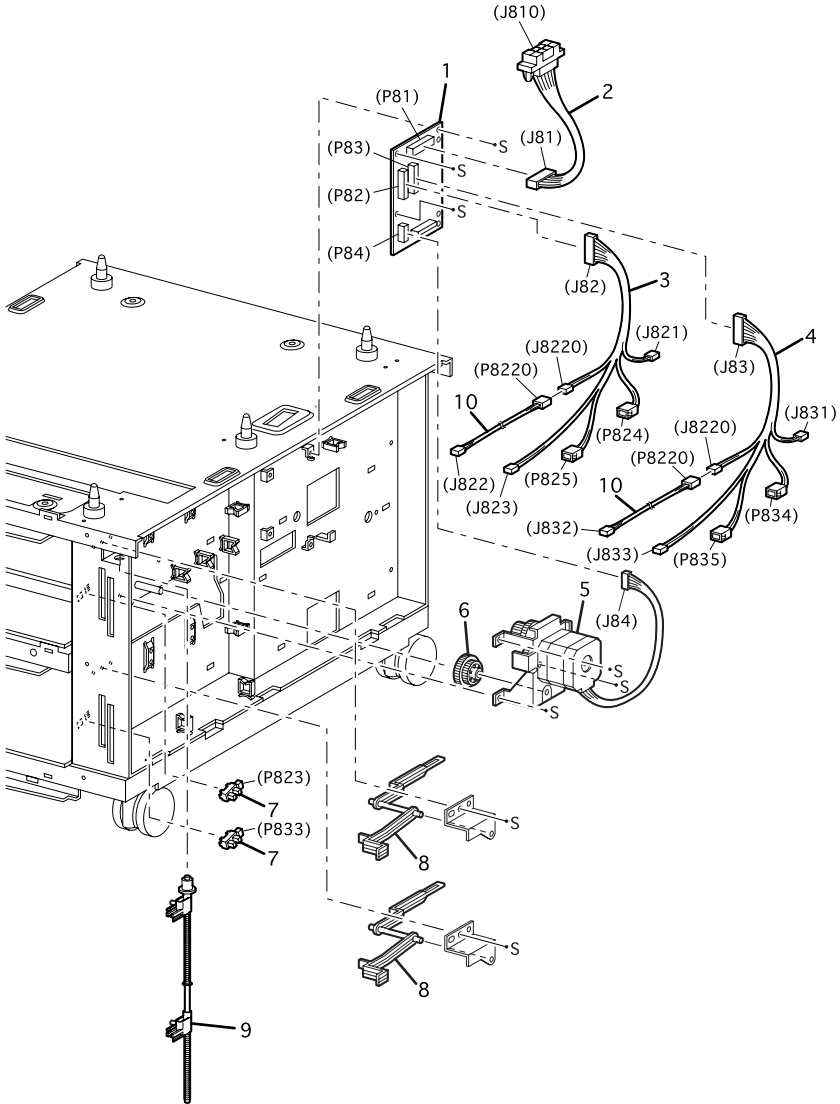

6250-485

PL 14.5 High-Capacity Feeder Harness, Board, Motor - Service Parts List Table

ID No.	Part Number	Qty	Name/Description
1.	116-1622-00*	1	Circuit Board, Lower Feeder
2.	116-1519-00	1	Assembly, OPT Feeder Plug
3.	116-1623-00*	1	Assembly, Harness, Tray 3
4.	116-1521-00	1	Assembly, Harness, Tray 4
5.	116-1624-00*	1	Assembly, Drive, Feeder
6.		1	Gear, Idler (NS, part of PL 3.3.99)
7.	116-1354-00	2	Sensor, No Paper, Low Paper (1 per order)
8.	116-1524-00	2	Lever, Low Paper (1 per order)
9.	116-1525-00		Assembly, Indicator
10.	116-1526-00		Assembly, Harness, NPRSJ

Optional 500-sheet Feeder

PL 15.1 Paper Tray 3

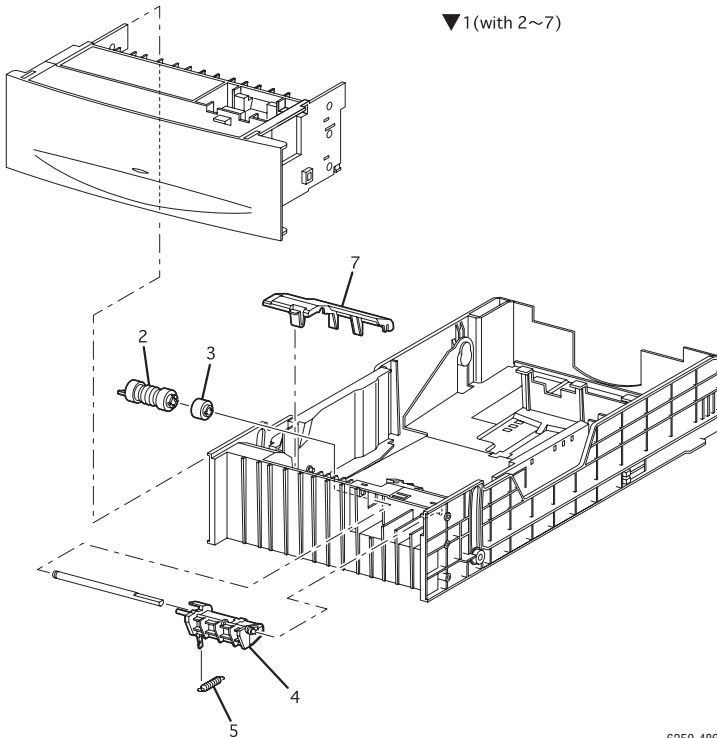

6250-486

PL 15.1 Tray 3, Universal Paper - Service Parts List Table

ID No.	Part Number	Qty	Name/Description
1.	116-1378-00*	1	Universal Paper Tray (with 2~6)
2.	116-1331-00	2	Paper Feed Roller Kit** **(2 interchangeable rollers per order)
3.	116-1332-00	1	Assembly, Friction Clutch
4.		1	Holder, Retard (NS)
5.	116-1632-00*	1	Spring, Retard
6.			
7.	116-1490-00		Chute Guide Cover

PL 15.2 500-sheet Feeder Covers

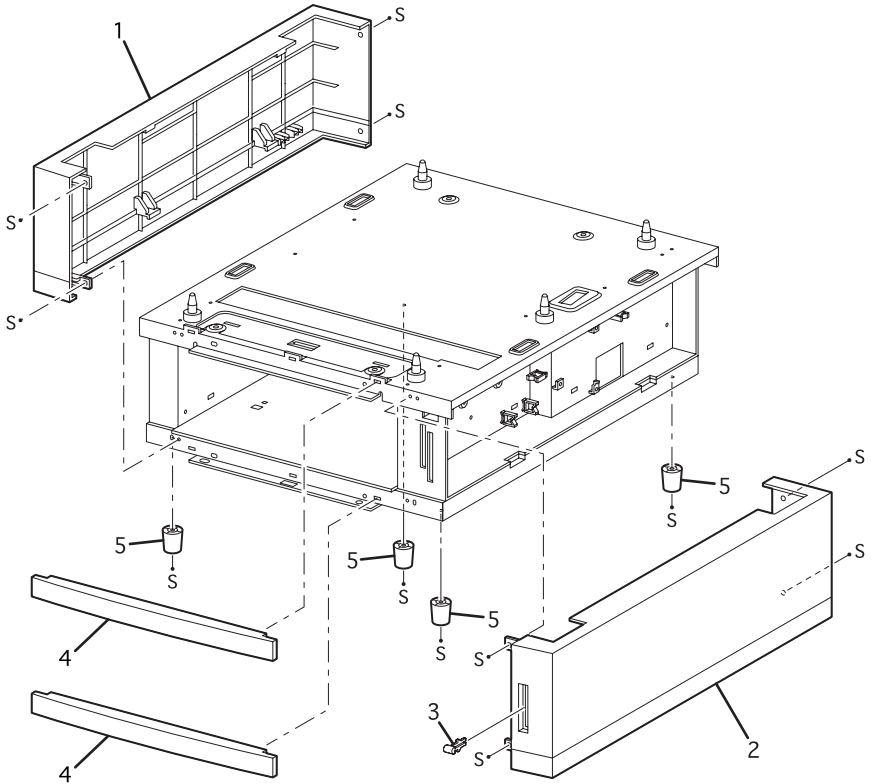

6250-427

PL 15.2 500-sheet Feeder Covers- Service Parts List Table

ID No.	Part Number	Qty	Name/Description
1.		1	Cover, Left (NS)
2.		1	Cover, Right (NS)
3.		1	Indicator, Paper (1per order) (NS)
4.		2	Cover, Front (1 per order) (NS)
5.	116-1626-00*	4	Kit, Feet (4 Feet and 4 screws)

PL 15.3 500-sheet Feeder Guides and Turn Chute Assembly

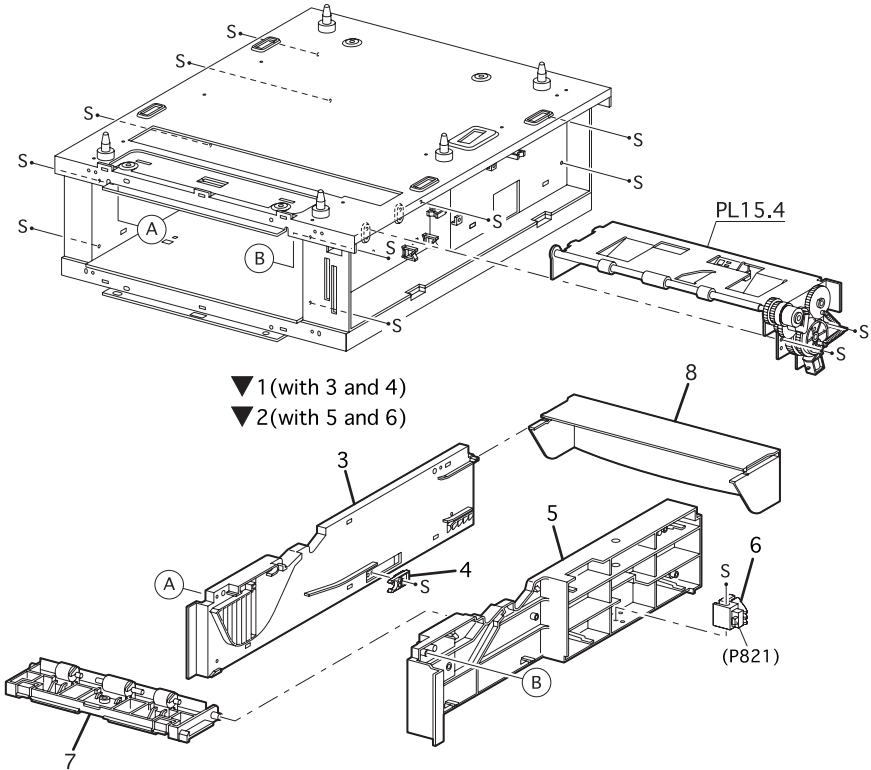

6250-428

PL 15.3 500-sheet Feeder Guides and Chute - Service Parts List Table

ID No.	Part Number	Qty	Name/Description
1.			Guide Assembly, Left (with 3 and 4) (NS)
2.			Guide Assembly, Right (with 5 and 6) (NS)
3.	116-1515-00	1	Guide, Tray Left
4.	116-1351-00	1	Paper Tray Stopper
5.	116-1516-00	1	Guide, Tray Right
6.	116-1343-00	1	Assembly, Paper Size Switch
7.	116-1336-00	1	Assembly, Turn Chute
8.	116-1491-00*	1	Cover, Paper Tray, Rear

PL 15.4 Paper Pick Assembly Tray 3

▼ 1 (with 2~5, 7~23)

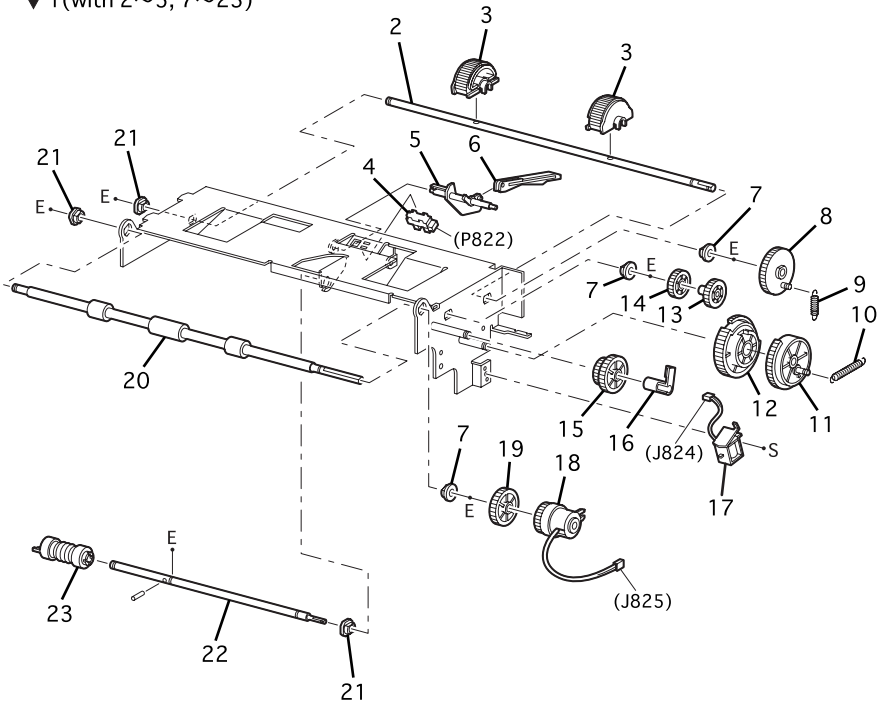

▼ 98 (with 3X2pcs)

▼ 99 (with 8, 11~15 and 19)

6250-429

PL 15.4 Paper Pick Assembly Tray 3 - Service Parts List Table

ID No.	Part Number	Qty	Name/Description
1.	116-1517-00	1	Paper Pick Assembly, LTA (with 2~5, 7~23)
2.		1	Shaft, Feed 1 (NS)
3.	116-1353-01	2	Paper Pick Roller Kit (2 per order)
4.	116-1354-00	1	Sensor, No Paper, Low Paper
5.	116-1355-00	1	Actuator, No Paper
6.	116-1356-00	1	Actuator, Link (Not included with Item 1)
7.		3	Bearing - Metal (NS)
8.		1	Gear, Feed 1 (NS)
9.		1	Spring, Feed 1 (NS)
10.		1	Spring, Feed H (NS)
11.		1	Gear, Feed H2 (NS part of 99)
12.		1	Gear, Feed H1 (NS part of 99)
13.		1	Gear, Feed 2 (NS part of 99)
14.		1	Gear, Idler Feed (NS part of 99)
15.		1	Gear, Idler (NS part of 99)
16.		1	Clutch Stopper (NS)
17.	116-1361-00	1	Feed Solenoid,
18.	116-1362-00	1	Assembly, Turn Clutch
19.		1	Gear, Idler In (NS part of 99)
20.	116-1363-00	1	Assembly, Roll Turn
21.		2	Bearing, Black (NS)
22.		1	Shaft, Feed 2 (NS)
23.	116-1331-00	2	Paper Feed Roller Kit** **(2 interchangeable rollers per order)
99.	116-1367-00	1	Paper Feed Gear Kit (with 8, 11~15 and 19)

PL 15.5 500-sheet Feeder Harness, Board and Motor

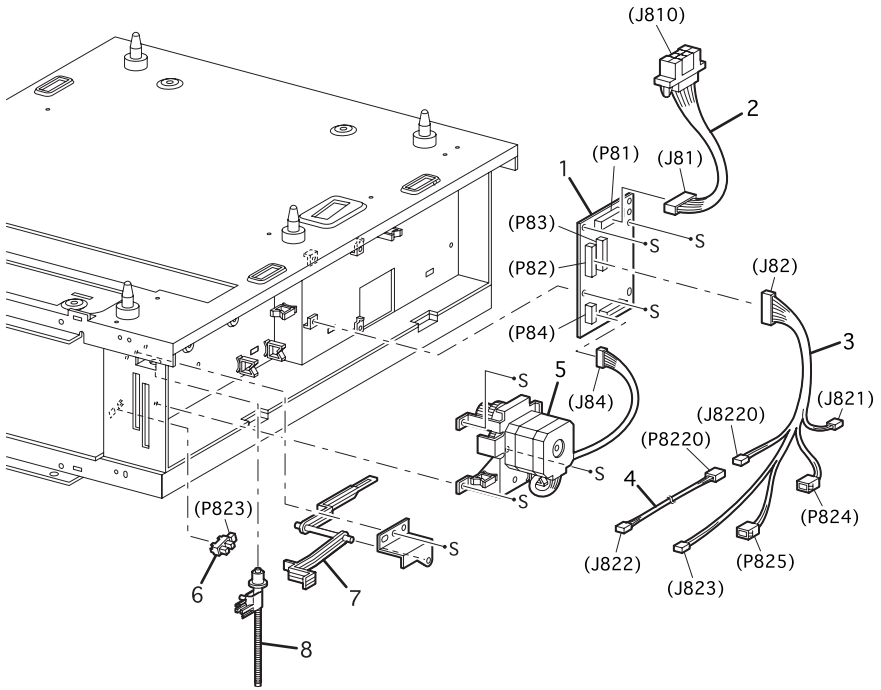

6250-430

PL 15.5 500-sheet Feeder Harness, Board, Motor - Service Parts List Table

ID No.	Part Number	Qty	Name/Description
1.	116-1622-00*	1	Circuit Board, Lower Feeder
2.	116-1519-00	1	Assembly, OPT Feeder Plug
3.	116-1623-00*	1	Assembly, Harness, Tray 3
4.	116-1526-00	1	Assembly, Harness, NPRSJ
5.	116-1635-00*	1	Assembly, Drive, Feeder (Single Tray)
6.	116-1354-00	1	Sensor, No Paper, Low Paper
7.	116-1524-00	1	Lever, Low Paper
8.		1	Assembly, Indicator (NS)

Xerox Supplies and Accessories

Repair Kits, World Kits and Repacking Kits

Description	Part Number
Kit, Gear, Paper Feed	116-1367-00
Kit, Bush, Exit Chute	116-1596-00*
Kit, OHP Sensor with Harness	116-1459-00
Kit, Registration Sensor Actuator and Spring	116-1627-00*
Kit, Printer Feet	116-1625-00*
Kit Screw, Assorted	116-1527-00
Kit, Long Screw (M3 x 85) (2 each)	212-0237-00
Kit, E-Rings, Assorted	116-1528-00
Kit, Sensor Actuator, Assorted Actuators	116-1131-00*
Kit, Paper Feed Rollers (2 interchangeable Rollers per)	116-1331-00
Paper Pick Rollers (2 interchangeable Rollers per)	116-1353-01
Main Shipping Box, Phaser 6250	004-5317-00*
Phaser 6250, World Kit	061-4482-00*
Repackaging Kit, Phaser 6250	065-0625-00
Repackaging Kit, High-Capacity Feeder, Phaser 6250	065-0611-00*
Repackaging Kit, 500 Sheet Feeder, Phaser 6250	065-0627-00*

Power Cords

Description	Part Number
Cable Assy, 3,18AWG, 115 V, 98, 0L	161-0066-00
Cable PWR EURO 220V , 99L	161-0066-09
Cable PWR U.K. 240 V, 96L	161-0066-10

Power Cords

Description	Part Number
Cable PWR AUST 240 V, 96L	161-0066-11
Cable Assy SWISS 220/240 V, 50 Hz	161-0154-00
Cable Assy PWR. DANISH, 250 V	161-0240-00
Cable Assy PWR, PRC	161-0304-00
Power, 240 V, ARGENTINA	161-0307-00

Upgrade Kits and Options

Description	Part Number
Internal Hard Drive, Service Part	650-4281-00*
Memory	
64 MB, 8M x 64, PC133; Memory DIMM	156-4838-00
128 MB, 16M x 64, PC133; Memory DIMM	156-4837-00
256 MB, 32M x 64, PC133; Memory DIMM	156-4663-00
High-Capacity Feeder w/ Trays	119-6474-00*
Casters Non-Locking	116-0008-00
Casters Locking	116-0009-00
500-sheet Feeder w/ Tray	119-6418-00*
Printer Feet	116-1344-00
IC, Base Configuration Chip	163-1500-00*
IC, Network Configuration Chip	163-1501-00*
IC, DP/DX Configuration Chip	163-1502-00*
IC, Memory NVRAM	163-1459-00*

Consumables

Description	Part Number
Toner Cartridges - Phaser 6250 all	
Yellow Toner Cartridge, Standard-Capacity	106R00670*
Yellow Toner Cartridge, High-Capacity	106R00674*
Magenta Toner Cartridge, Standard Capacity	106R00669*
Magenta Toner Cartridge, High-Capacity	106R00673*

Consumables

Description	Part Number
Cyan Toner Cartridge, Standard-Capacity	106R00668*
Cyan Toner Cartridge, High-Capacity	106R00672*
Black Toner Cartridge, Standard-Capacity	106R00671*
Black Toner Cartridge, High-Capacity	106R00675*

Routine Maintenance Items

Description	Part Number
Imaging Unit, Phaser 6250	108R00591*
Fuser, Phaser 6250	
110 V	115R00029*
220 V	115R00030*
Transfer Roller	108R00592
Universal Paper Tray (2, 3, 4)	116-1378-00*
Paper Feed Roller Kit	116-1331-00

Software and Documentation

Description	Part Number
Printer Installer and Utilities CD-ROM	Included in World Kit
User Documentation CD-ROM	Included in World Kit
Service Manual	071-0869-00*

Phaser Media

Description	Part Number
Phaser Premium Paper, A, 500 Sheets	016-1368-00
Phaser Premium Paper, A4, 500 Sheets	016-1369-00

Phaser Media (Continued)

Description	Part Number
Phaser Glossy Coated Paper, A, 100 Sheets	016-1704-00
Phaser Glossy Coated Paper, A4 100 Sheets	016-1705-00
Phaser Color Printing Labels, A, 30 per, 100 Sheets	016-1812-00
Phaser Color Printing Labels, A, 6 per, 100 Sheets	016-1813-00
Phaser Color Printing Labels, A4, 14 per, 100 Sheets	016-1814-00
Phaser Color Printing Labels, A4, 8 per, 100 Sheets	016-1815-00
Phaser Premium Cover Paper, A, 100 Sheets	016-1823-00
Phaser Premium Cover Paper, A4, 100 Sheets	016-1824-00
Phaser CD/DVD Label and Applicator; contains 1 Applicator & 1 Jewel Case	016-1885-00
Phaser CD/DVD Labels and Inserts, 1 Insert/Sheet, Letter (8.5 x 11 in.), 20 Sheets, 2 Labels per Sheet, 10 Sheets	016-2011-00
Phaser CD/DVD Labels and Inserts, A4, (210 x 297mm) 1 Insert/Sheet, 20 Sheets, 2 Labels per Sheet, 10 Sheets	016-2026-00
Phaser Premium Business Card Media, A, 10 per 25 Sheets	016-1898-00
Phaser Premium Business Card Media, A4, 10 per 25 Sheets	016-1899-00
Phaser 25-Series Premium Transparency Film, Letter (8.5 x 11 in.), 50 Sheets	016-1948-00
Phaser 25-Series Premium Transparency Film, A4 (210 x 297mm), 50 Sheets	016-1949-00
Phaser Premium Greeting Cards w/ Envelopes, A, 50 sheets	016-1987-00
Phaser Premium Greeting Cards w/ Envelopes, A4, 50 sheets	016-1988-00
Phaser Digital Photo Paper, A, 50 Sheets	016-2009-00

Phaser Media (Continued)

Description	Part Number
Phaser Digital Photo Paper, A4, 50 Sheets	016-2010-00
Phaser Premium Postcards, Letter (8.5 x 11 in.), 100 Sheets	103R01016
Phaser Premium Postcards, A4 (210 x 297mm), 100 Sheets	103R01017
Phaser Glossy Trifold Brochure, Letter (8.5 x 11 in.), 100 Sheets	103R01018
Phaser Glossy Trifold Brochure, A4 (210 x 297mm), 100 Sheets	103R01019
Phaser Weatherproof Paper, Letter (8.5 x 11 in.), 150 Sheets	103R01020
Phaser Weatherproof Paper, A4 (210 x 297mm), 150 Sheets	103R01021

Wiring Diagrams

In this chapter...

- Plug/Jack Locator Maps
- Print Engine Wiring Diagrams
- Printer Options Wiring Diagrams

Chapter 10



Plug/Jack Locator Maps

Use the table and maps in this section to locate specific Plug/Jack (P/J) connectors within the printer.

To find the location of a P/J within the printer:

1. Locate the P/J connector number in the first column of the P/J Location table.
2. Locate the corresponding map and location number, such as M2-5, in the second column.
3. With this information, go to the appropriate map (in this case, Map 2) and locate item number 5.

Plug/Jack Locator Table

P/J No.	Map	Connected to...	Other end connected to...
11	3	Engine Control Board	Motor Driver Board
12	3	Engine Control Board	Motor Driver Board
13	3	Connects: Engine Control Board, Sub-HVPS, Fuser Harness Assembly, Harness Assembly FRONT 1A and the CTD (ADC) Harness Assembly.	
14	3	Engine Control Board	Image Processor Board
15	3	Engine Control Board	Laser Unit
18	3	Engine Control Board	Chute Assembly Registration (Clutch and Sensor)
19	3	Engine Control Board	Retard Housing Assembly (Turn Clutch)
21	3	Engine Control Board	HCF Main Harness Assembly
22	3	Engine Control Board	Front Panel Harness Assembly
23	3	NC	NC
24	3	Engine Control Board	Fuser Harness, Temp/Hum Sensor Harness Assembly
30	3	NC	
31	3	NC (Test-Print)	
32	3	Engine Control Board	OHP Sensor
34	3	Engine Control Board	CRUM Reader Harness
41	2	Motor Driver Board	Engine Control Board

Plug/Jack Locator Table (Continued)

P/J No.	Map	Connected to...	Other end connected to...
42	2	Motor Driver Board	Engine Control Board
47	2	Connects: Motor Driver Board, Paper Pick Assembly (No Paper Sensor, Low Paper Sensor, Solenoid Feed, Clutch Turn) and Paper Size Switch	
48	2	Motor Driver Board	Main Drive Assembly
49	2	Motor Driver Board	Developer Drive Assembly
50	2	Connects: Motor Driver Board, Chute Assembly Exit (Duplex Motor Assembly) and Front Cover Assembly (Fan Fuser)	
51	2	Motor Driver Board	Toner Cartridge Holder Assembly (Toner Present Sensor, Low Toner Sensor, Toner Motor, and CRUM Reader Board)
52	2	Motor Driver Board	Chute Assembly, In (Fuser Drive)
60	2	Motor Driver Board	LVPS Assembly
61	2	Motor Driver Board	LVPS Assembly
71	3	EEPROM Harness Assembly	Plate Dispenser L Assembly
131	1	Chute Assembly, Exit (Duplex Motor Assembly)	Engine Control Board
132	1	Chute Assembly Out (MPT Feed Solenoid)	FRONT 1A Harness Assembly
133	1	Chute Assembly, Out (Duplex Jam Sensor)	FRONT 1A Harness Assembly
134	1	Chute Assembly, Out (Full Stack Sensor)	FRONT 1A Harness Assembly
135	1	Chute Assembly, Out (Tray 1 (MPT) No Paper Sensor)	FRONT 1A Harness Assembly
136	2	Assembly, Front In (Sensor CTD (ADC) Assembly)	FRONT 1A Harness Assembly
137	1	Front Cover (Fan Fuser)	Motor Driver Board
138	3	FRONT 1A Harness Assembly	Fuser Assembly
139	3	FRONT 1A Harness Assembly	Chute Assembly, Out (Tray 1 (MPT) Feed Solenoid, Duplex Jam Sensor, Full Stack Sensor, Tray 1 (MPT) No Paper Sensor)

Plug/Jack Locator Table (Continued)

P/J No.	Map	Connected to...	Other end connected to...
140	3	Connects: Engine Control Board, CRUM Harness Assembly, Toner Full Sensor Harness Assembly, EEPROM Circuit Board.	
141	3	EEPROM Harness Assembly	Chute Assembly, In (Toner Full Sensor)
142	2	Chute Assembly In (Toner Full Sensor)	EEPROM Harness Assembly
144	3	EEPROM Circuit Board (Yellow goes to top connector)	Engine Control Board
145	3	EEPROM Circuit Board (Grey goes to bottom connector)	Fuser Harness
151	2	Laser Unit	Engine Control Board
161	2	LVPS Assembly	Power Cord
162	2	LVPS Assembly	Fuser Assembly
163	2	LVPS Assembly	Motor Driver Board
164	2	LVPS Assembly	Engine Control Board
165	2	LVPS Assembly	Motor Driver Board
166	2	LVPS Assembly	Rear Fan
167	2	NC	NC
168	2	NC	Engine Control Board
181	3	Chute Assembly, Registration (Registration Sensor)	Engine Control Board
210	2	Lower Feeder Harness Assy	HCF-Plug
FPC*	1	Front Panel	OPEPANE Harness Assembly
221	3	OPEPANE Harness Assembly	Front Panel
231	4	Temp/Humidity Sensor	Temp/Humidity Harness Assembly
232	2	Fuser Assembly	FRONT 1A Harness Assembly
311	3	Engine Control Board	LVPS Assembly
321	3	OHP Sensor	Engine Control Board
341	1	CRUM Reader Board	CRUM Reader Harness

*FPC = Front Panel Connector

Plug/Jack Locator Table (Continued)

P/J No.	Map	Connected to...	Other end connected to...
342	1	CRUM Reader Board	Motor Driver Board
471	4	Paper Size Switch Assembly	Motor Driver Board
472	4	No Paper Sensor	Motor Driver Board
473	4	Low Paper Sensor	Motor Driver Board
474	4	Feed Solenoid	Motor Driver Board
475	4	Clutch Turn Assembly	Motor Driver Board
511	1	Holder Assembly MQ-Y (Toner Motor)	Motor Driver Board
512	1	Holder Assembly MQ-M (Toner Motor)	Motor Driver Board
513	1	Holder Assembly MQ-C (Toner Motor)	Motor Driver Board
514	1	Holder Assembly MQ-K (Toner Motor)	Motor Driver Board
701	1	Holder Assembly MQ-Y (Toner Present Sensor)	Motor Driver Board
702	1	Holder Assembly MQ-M (Toner Present Sensor)	Motor Driver Board
703	1	Holder Assembly MQ-C (Toner Present Sensor)	Motor Driver Board
704	1	Holder Assembly MQ-K (Toner Present Sensor)	Motor Driver Board
710	1	Plate Dispenser L	EEPROM Harness Assembly
810	4	High-Capacity Feeder	Engine Control Board
1361	3	FRONT 1A Harness Assembly	Chute Assembly, In (CTD (ADC) Sensor)
2361	3	Temp/Hum Harness Assembly	Engine Control Board
2362	3	Fuser Harness Assembly	Engine Control Board
3411	3	CRUM Reader Harness	CRUM Reader Board
5011	3	Sub-HVPS	Engine Control Board
5020	3	Sub-HVPS	Chute Assembly, In
5030	3	Sub-HVPS	Chute Assembly, In

Map 1

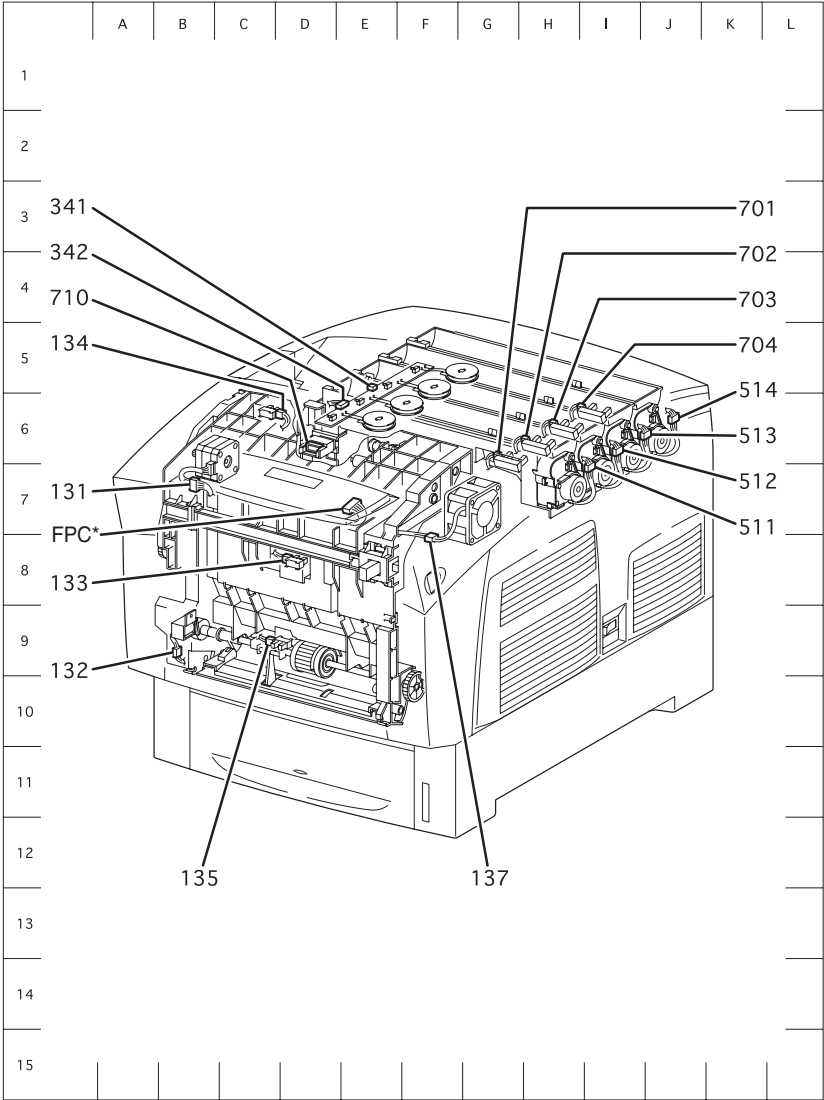

6250-306

* FPC = Front Panel Connector

Map 2

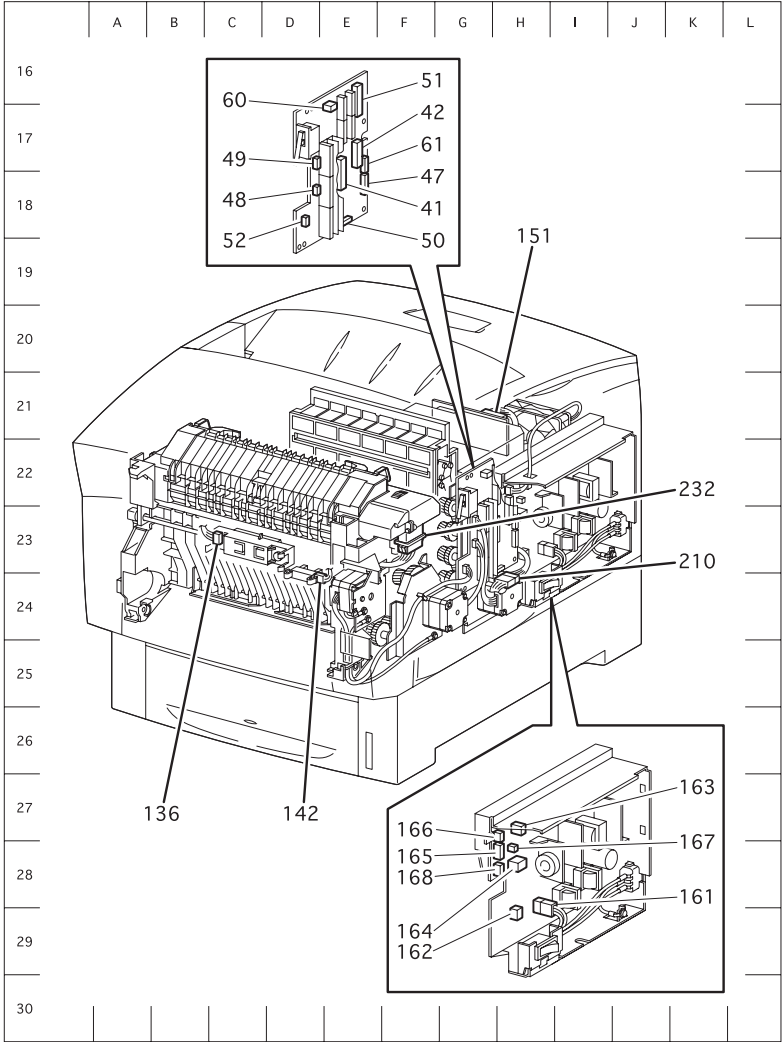

6250-307

Map 3

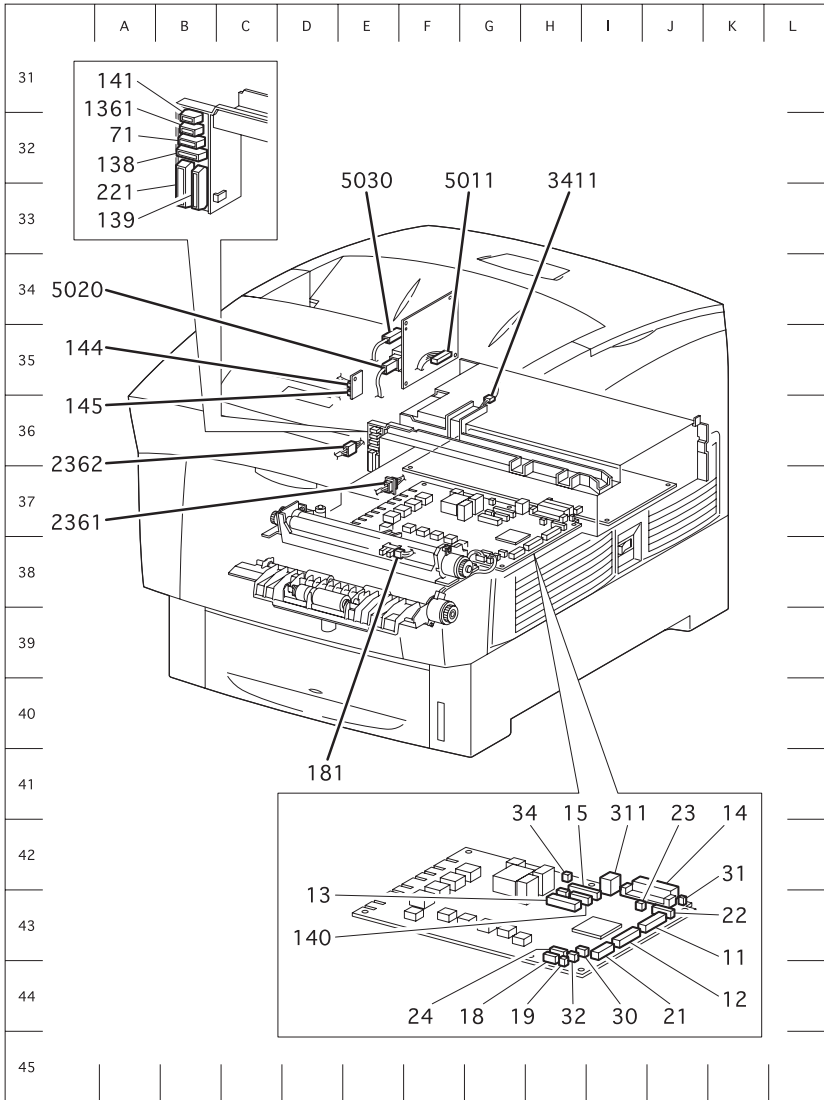

6250-308

Map 4

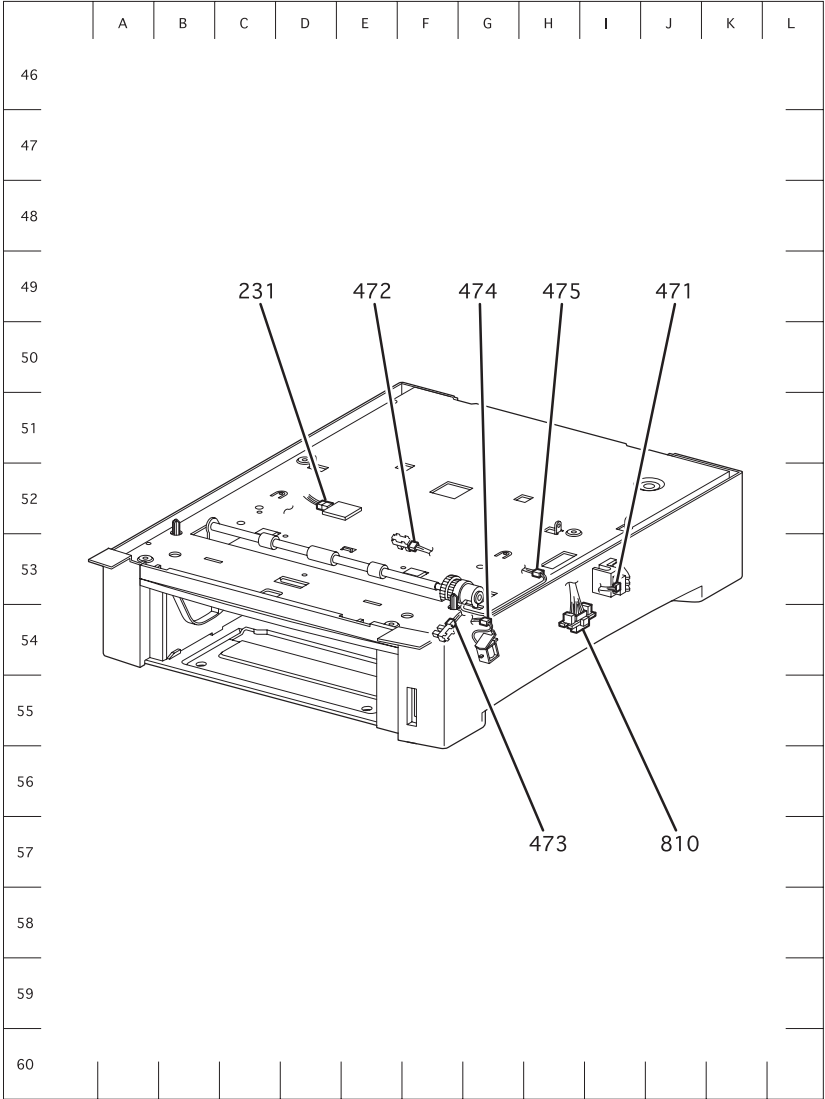

6250-309

High-Capacity Feeder Plug/Jack Locator Table

P/J No.	Connect to...	Other end connected to...
81	Circuit Board, Lower Feeder	Assembly, Harness HCF-PLUG
82	Circuit Board, Lower Feeder	Tray 3 Harness Assembly
83	Circuit Board, Lower Feeder	Tray 4 Harness Assembly
84	Circuit Board, Lower Feeder	Assembly, HCF Motor Harness
810	Assembly, Harness HCF Main	Circuit Board, HCF
821	Switch, Paper Size (T3)	Tray 3 Harness Assembly
822	Sensor, No Paper (T3)	Tray 3 Harness Assembly
823	Sensor, Low Paper (T3)	Tray 3 Harness Assembly
824	Solenoid Feed (Tray 3)	Circuit Board, HCF
825	Assembly, Clutch Turn (T3)	Circuit Board, HCF
831	Switch, Paper Size (T4)	Tray 4 Harness Assembly
832	Sensor, No Paper (Tray 4)	Tray 4 Harness Assembly
833	Sensor, Low Paper (T4)	Tray 4 Harness Assembly
834	Solenoid Feed (Tray 4)	Circuit Board, Lower Feeder
835	Assembly, Clutch Turn (T4)	Circuit Board, Lower Feeder
8220	Assembly, Harness No Paper Sensor	Circuit Board, Lower Feeder
8220	Assembly, Harness No Paper Sensor	Circuit Board, Lower Feeder

Map 5

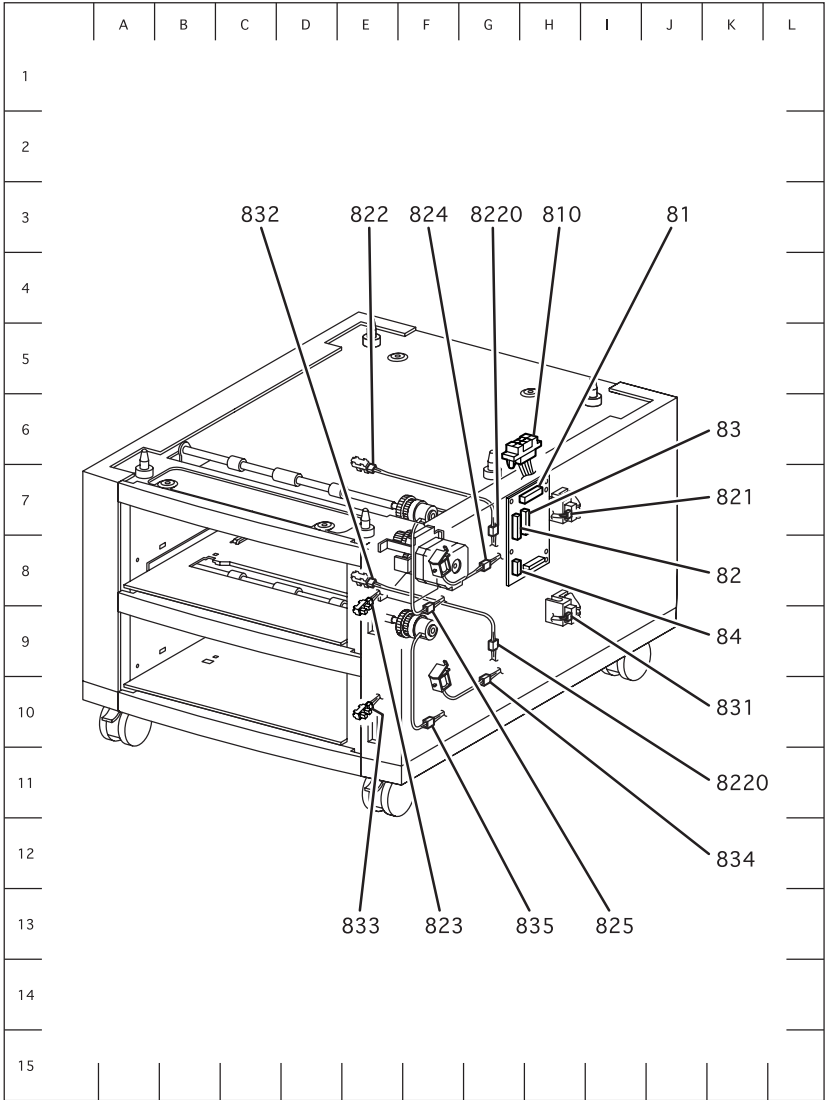

6250-487

500-sheet Feeder Plug/Jack Locator Table

P/J No.	Connect to...	Other end connected to...
81	Circuit Board, Lower Feeder	Assembly, Harness STF-PLUG
82	Circuit Board, Lower Feeder	Tray 3 Harness Assembly
83	Circuit Board, Lower Feeder	Not connected
84	Circuit Board, Lower Feeder	Assembly, STF Motor Harness
810	Assembly, Harness STF Main	Circuit Board, STF
821	Switch, Paper Size (T3)	Tray 3 Harness Assembly
822	Sensor, No Paper (T3)	Tray 3 Harness Assembly
823	Sensor, Low Paper (T3)	Tray 3 Harness Assembly
824	Solenoid Feed (Tray 3)	Circuit Board, STF
825	Assembly, Clutch Turn (T3)	Circuit Board, STF
8220	Assembly, Harness No Paper Sensor	Circuit Board, Lower Feeder

Map 6

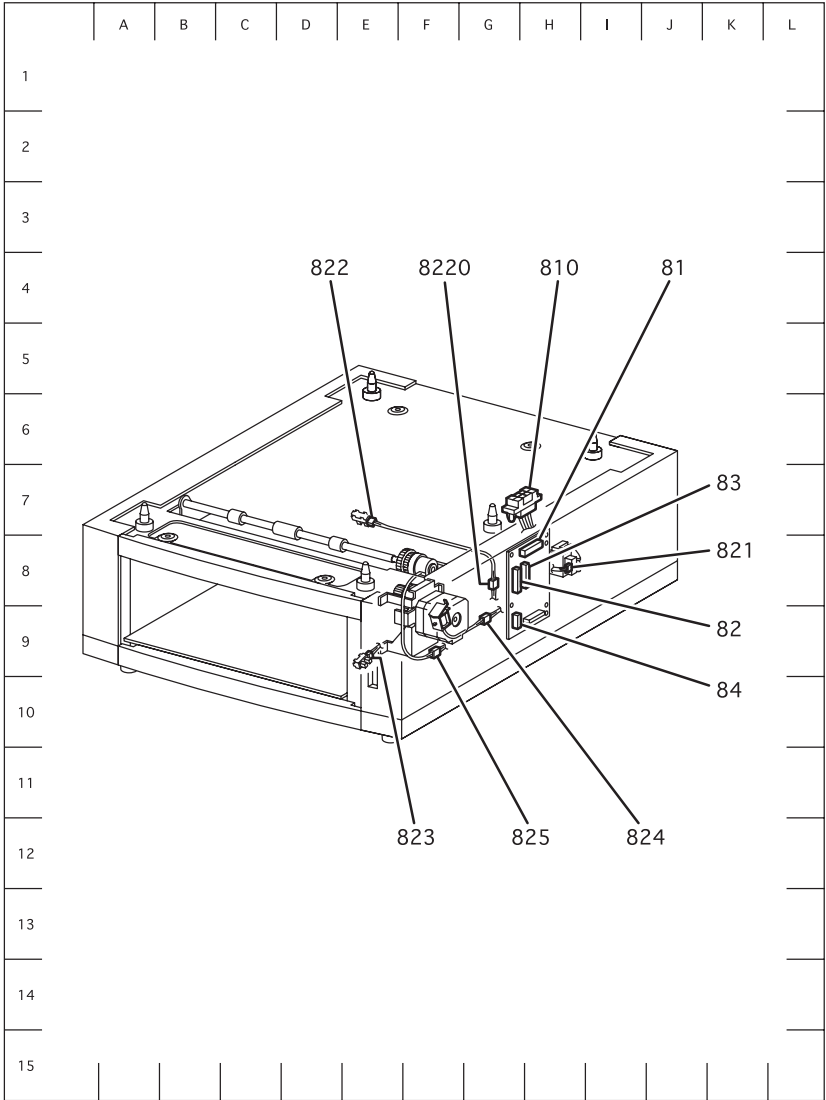

6250-431

Print Engine Wiring Diagrams

Notations used in Wiring Diagrams

Plug



Jack



Clutch/Solenoid

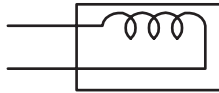

Motor



Optical Sensor

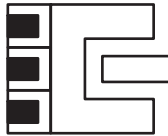

6250-499

Power Supplies

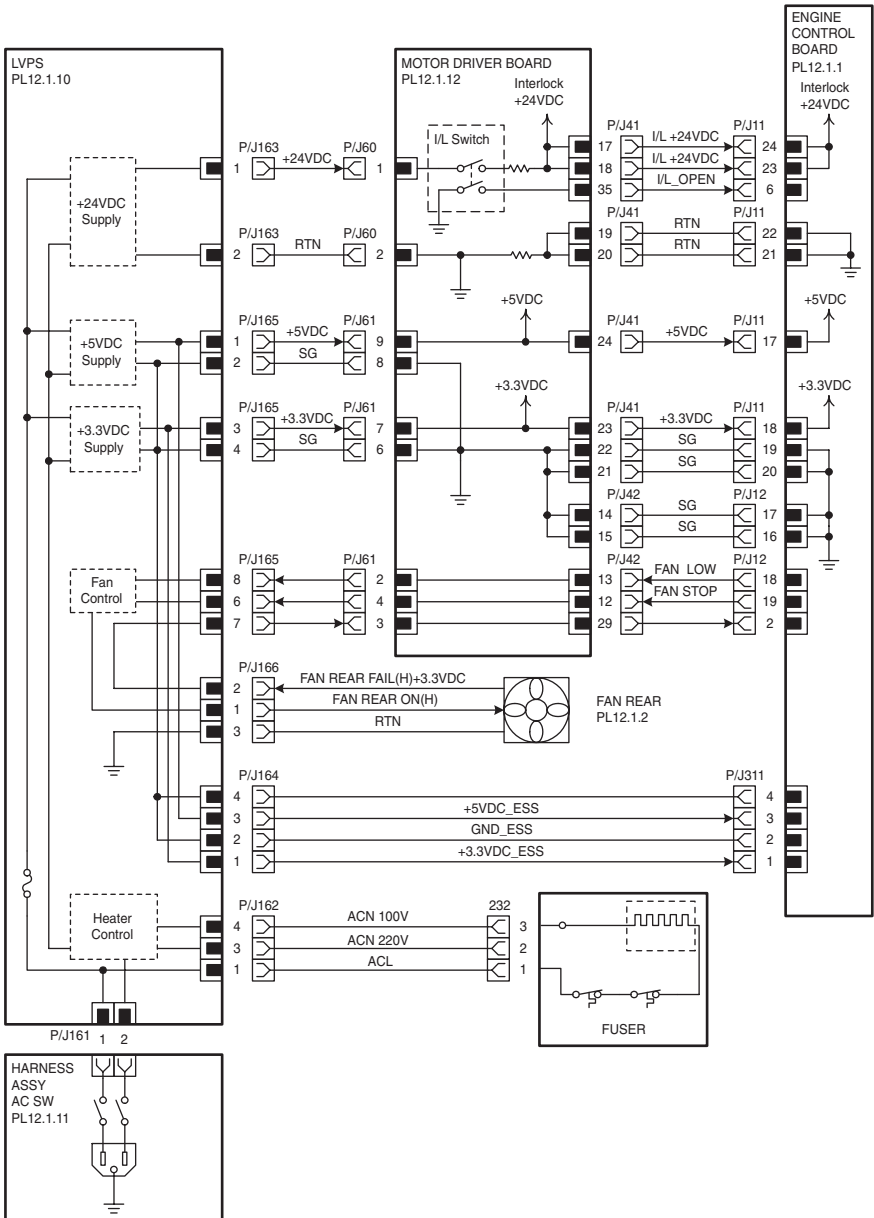

6250-311

Paper Tray 2

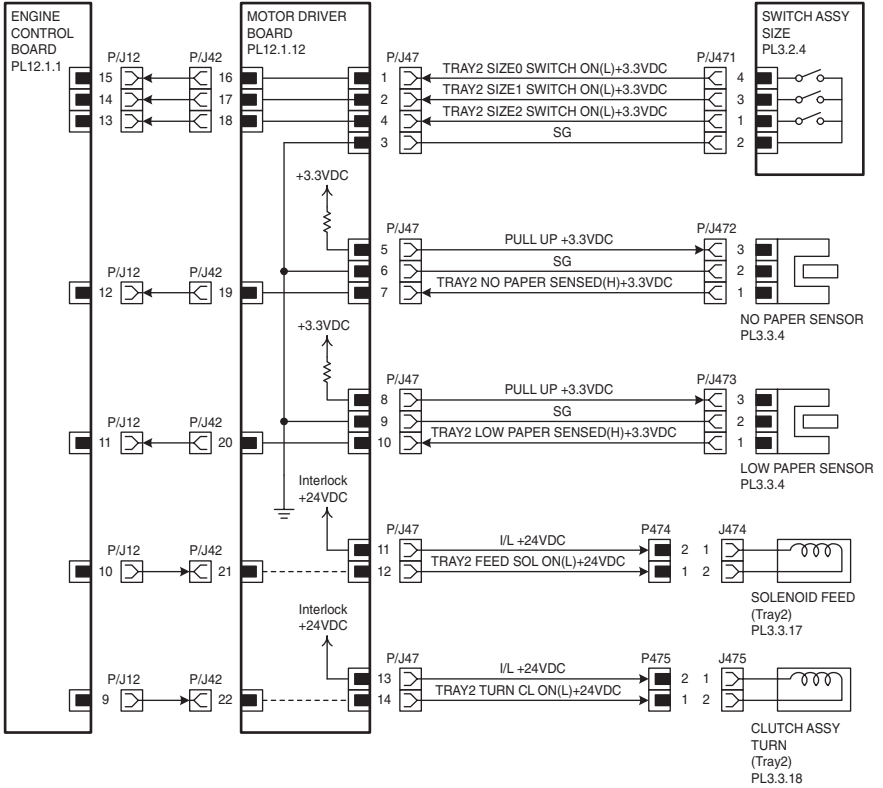

6250-312

Developer Section 1

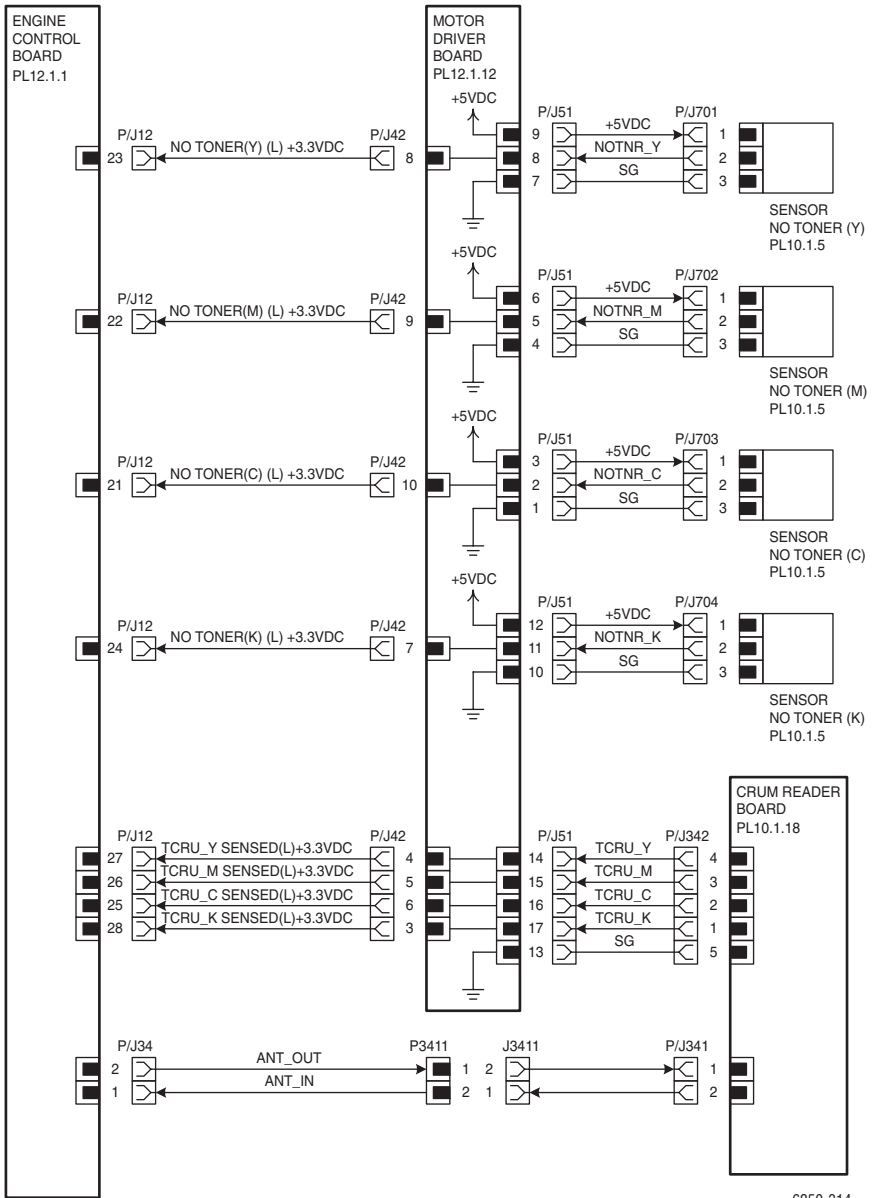

6250-314

Developer Section 2

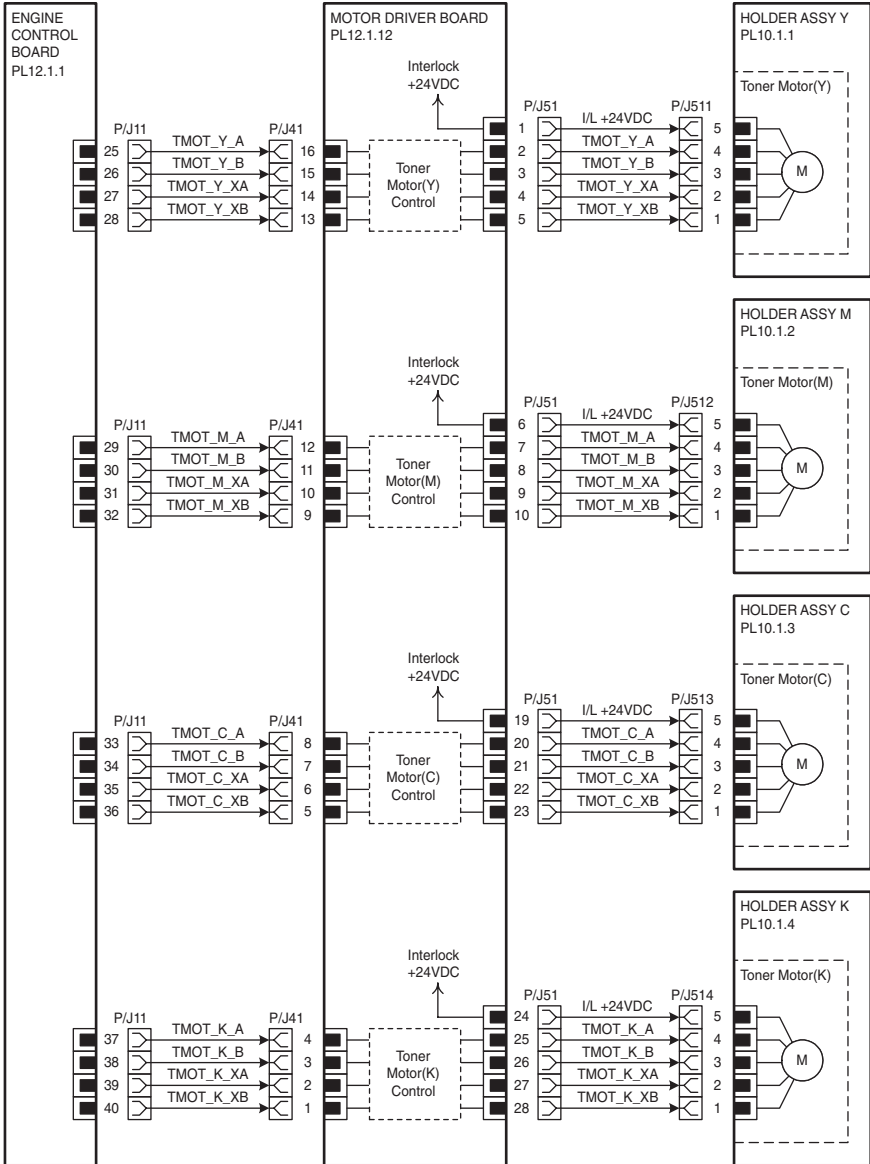

6250-315

Fuser Assembly

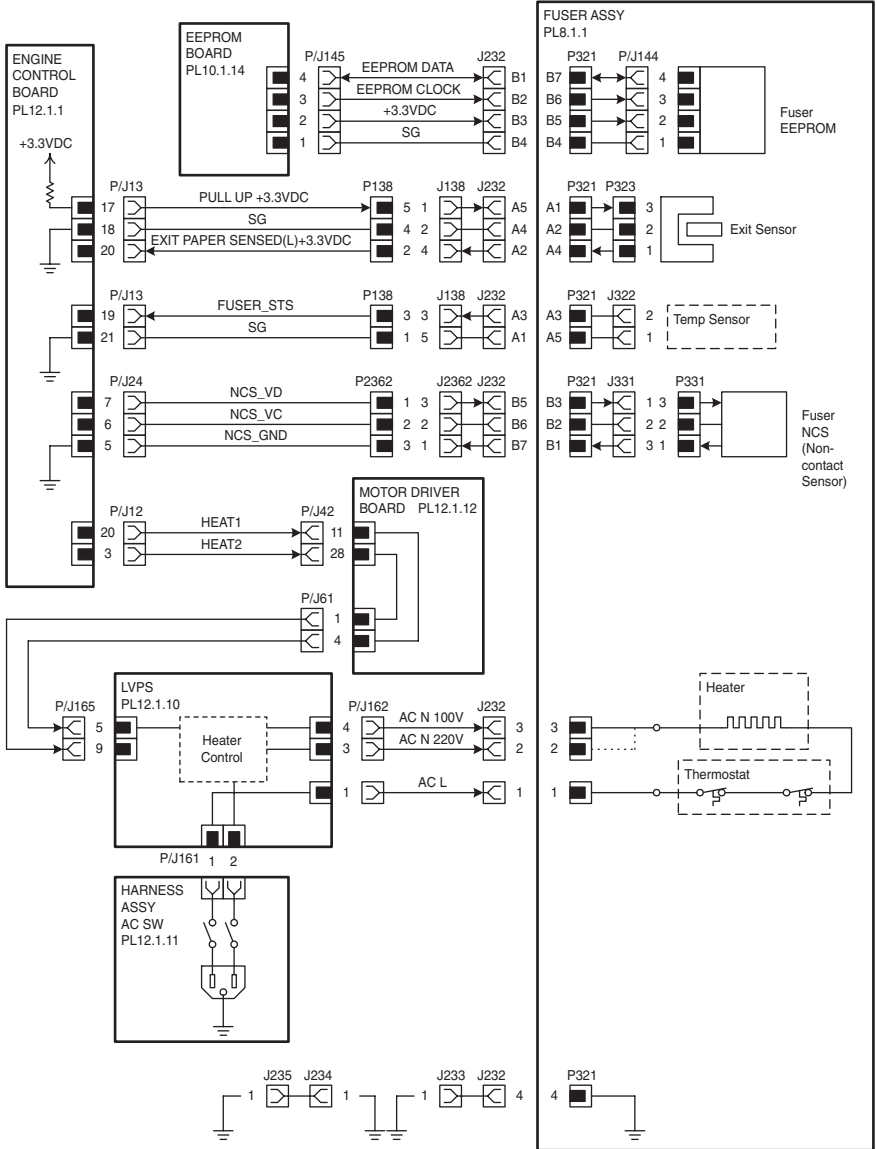

6250-316

Note:P/J numbers within the Fuser block are all internal to the Fuser Assembly.

Laser Unit

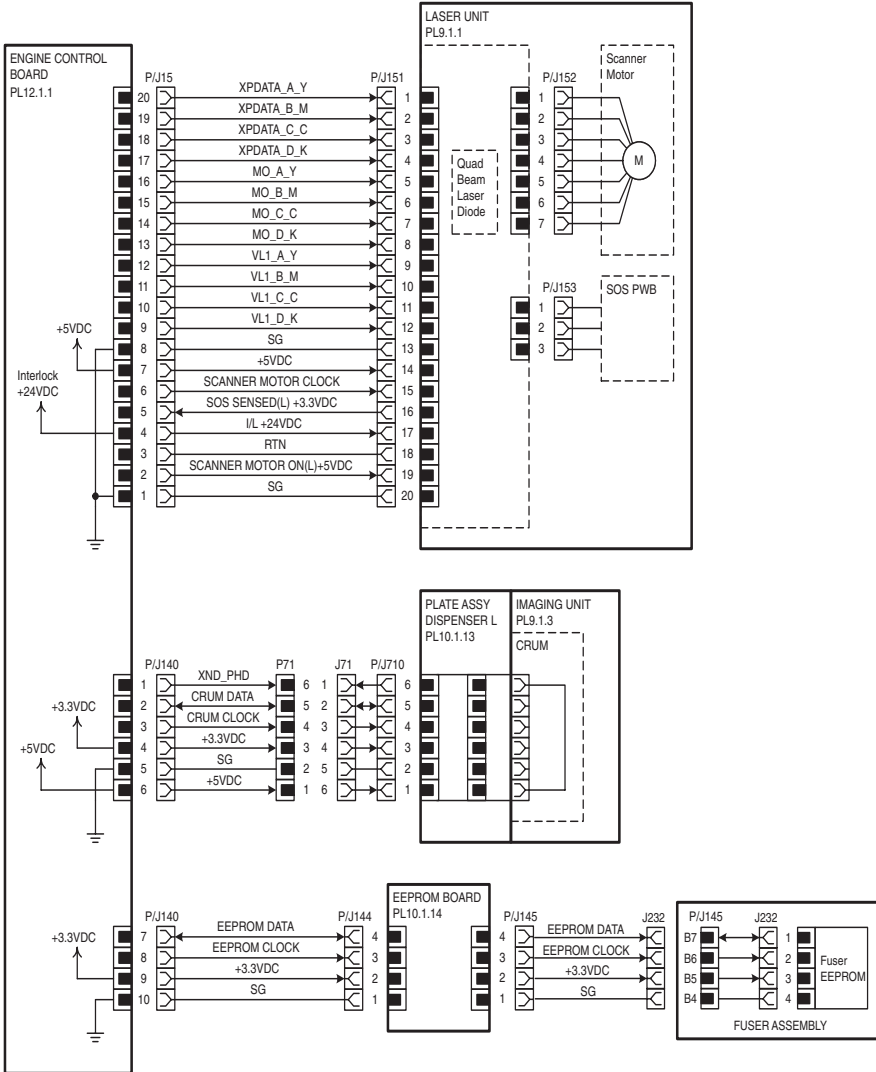

6250-317

Xerographics 1

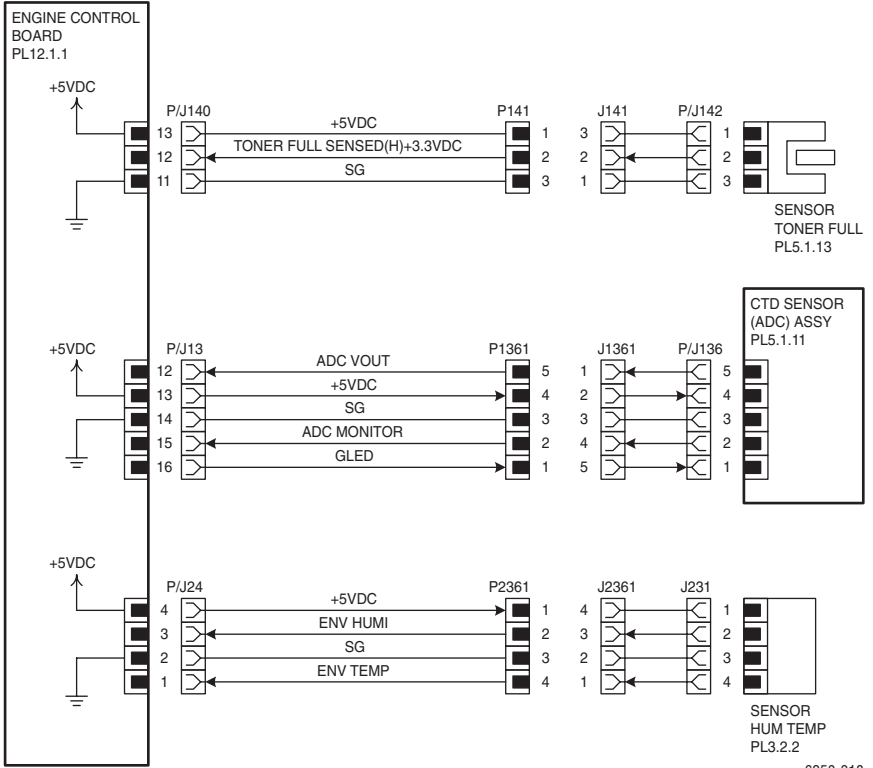

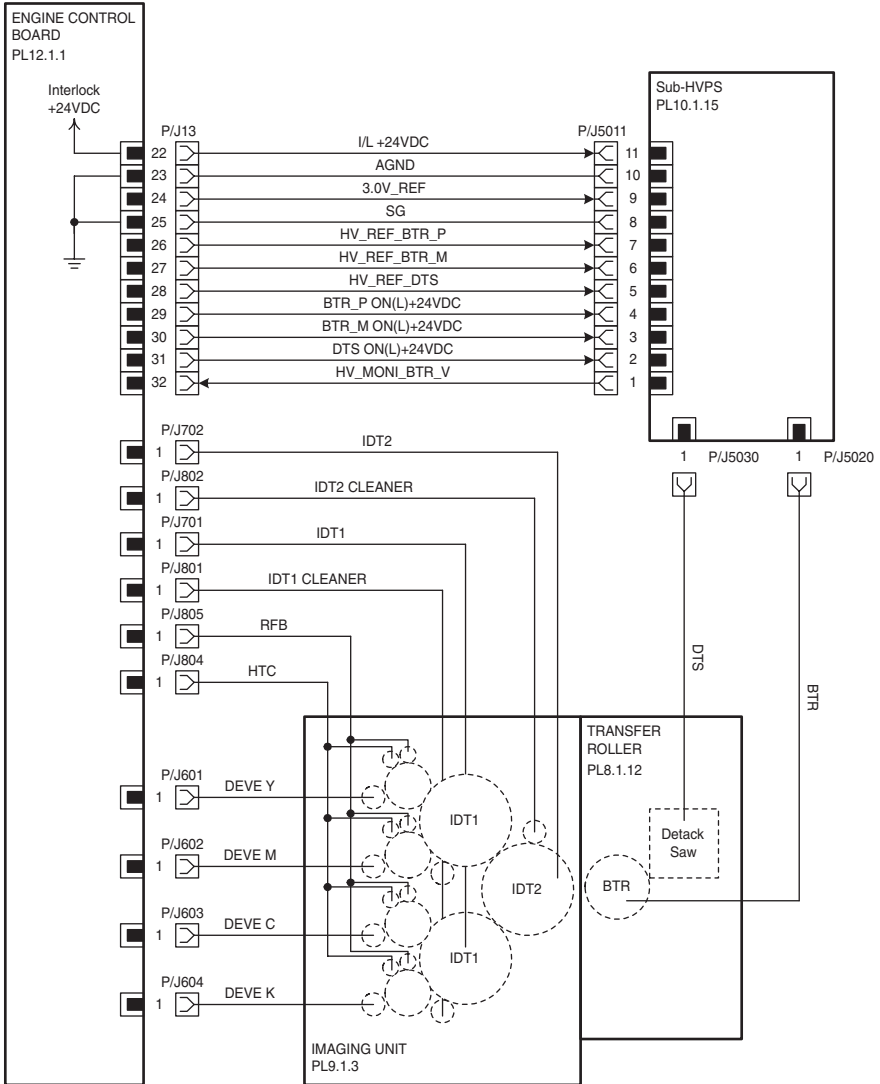

6250-319

Paper Feed

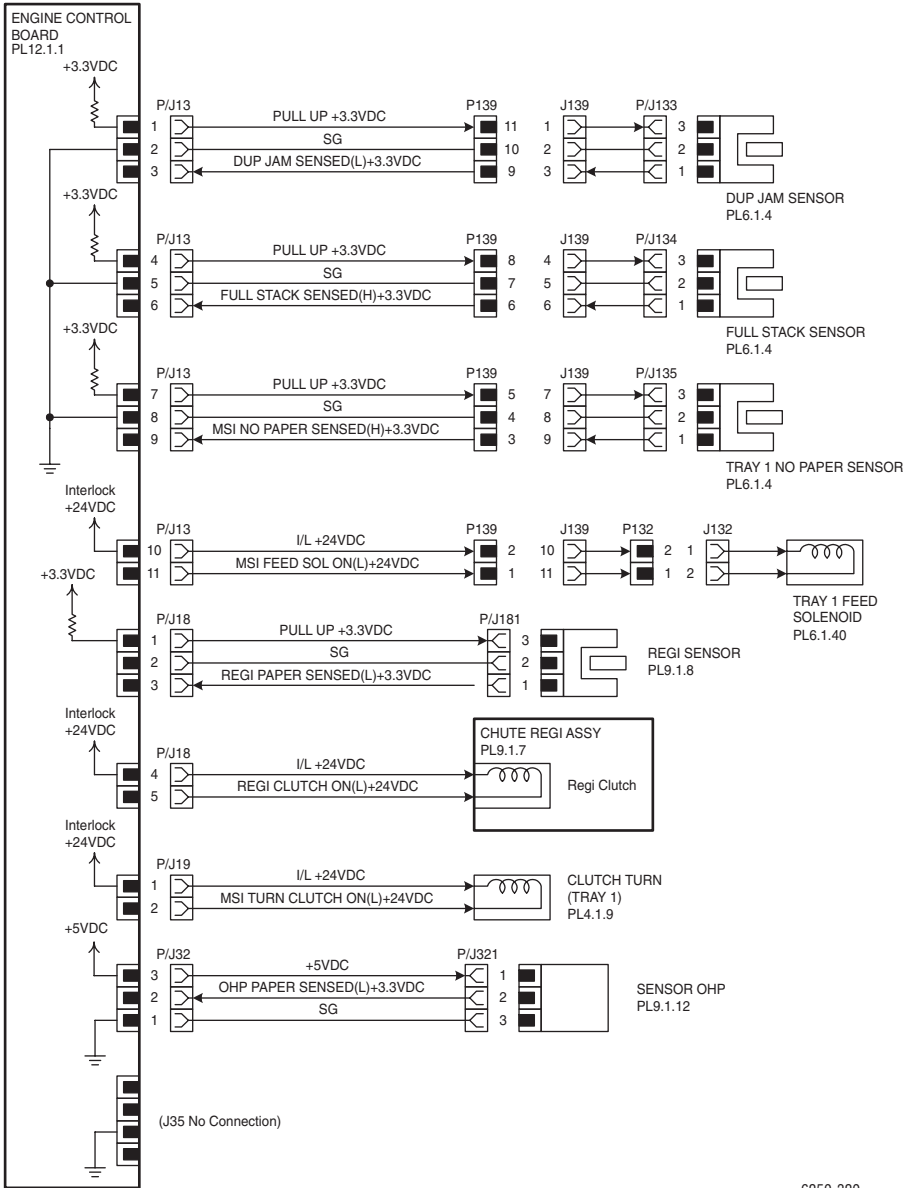

6250-320

Image Processor Board

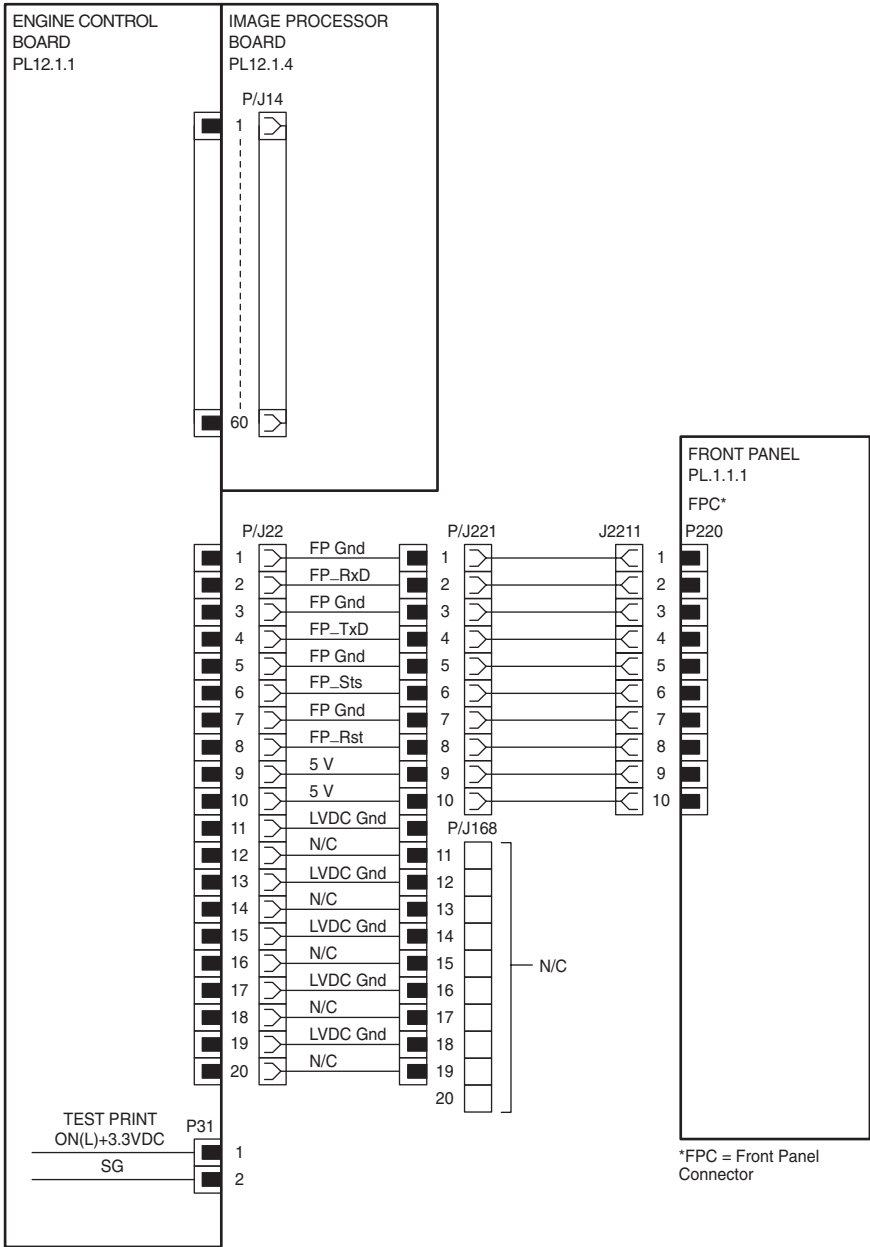

6250-321

Printer Options Wiring Diagrams

High Capacity Feeder Main Wiring Diagram

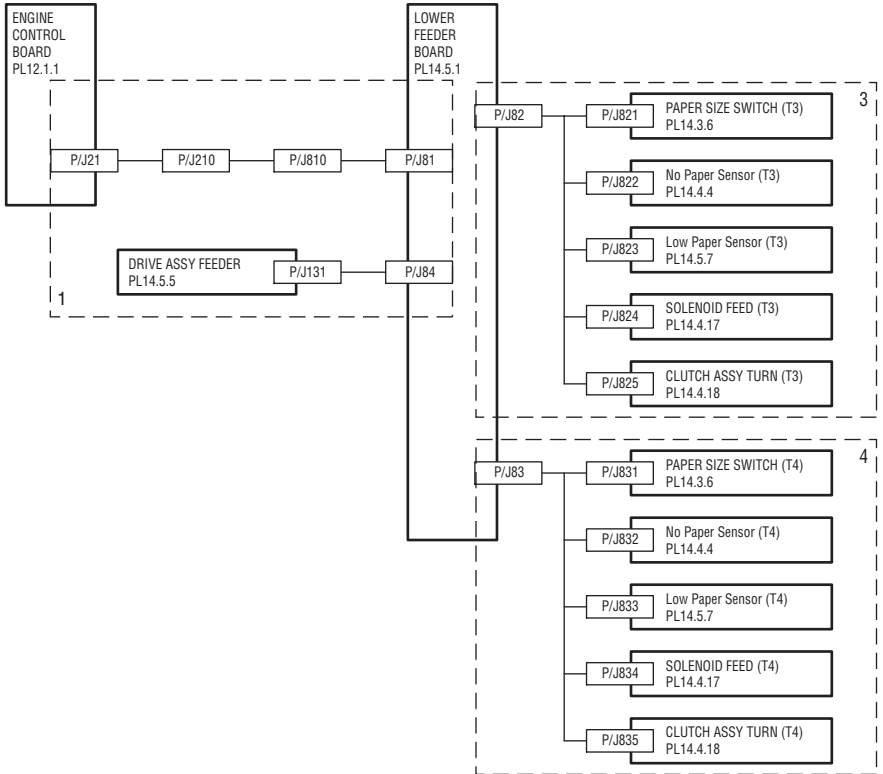

6250-488

Paper Tray 4

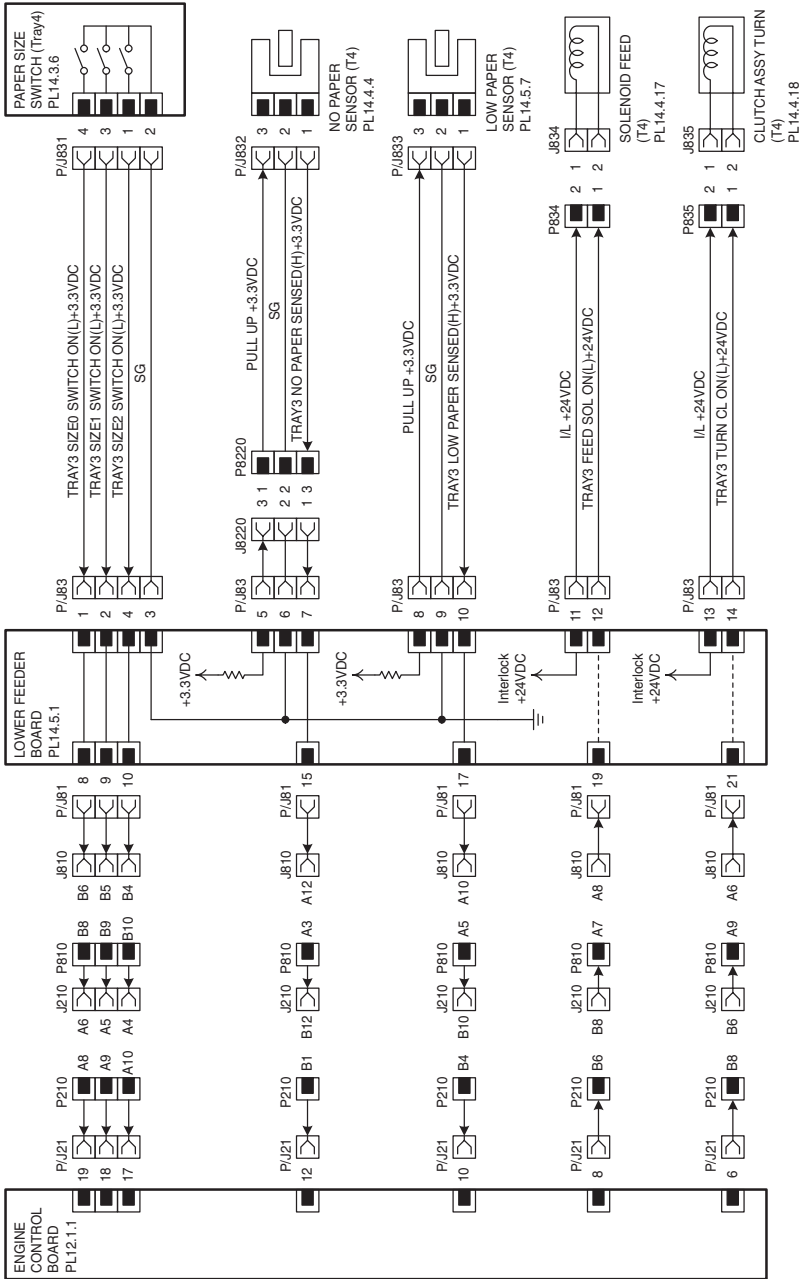

6250-491

500-sheet Feeder Main Wiring Diagram

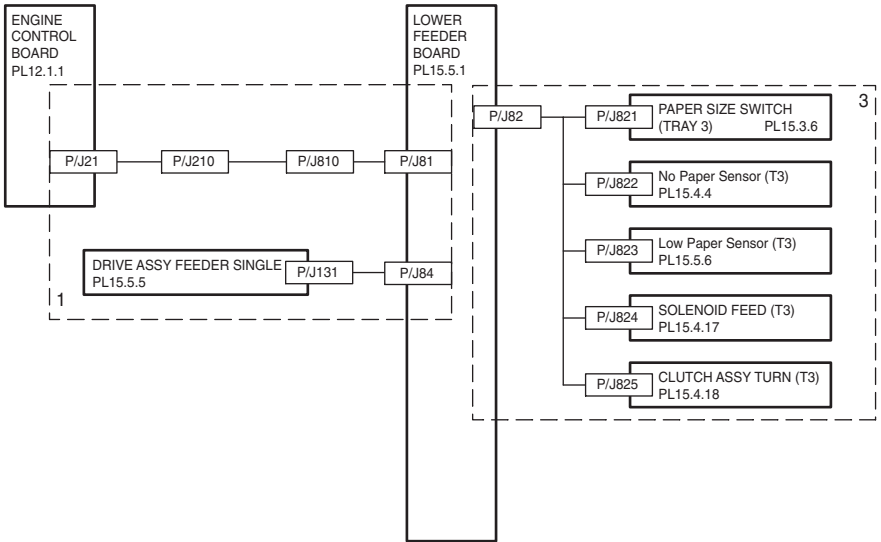

6250-432

Drive Section (STF)

6250-433

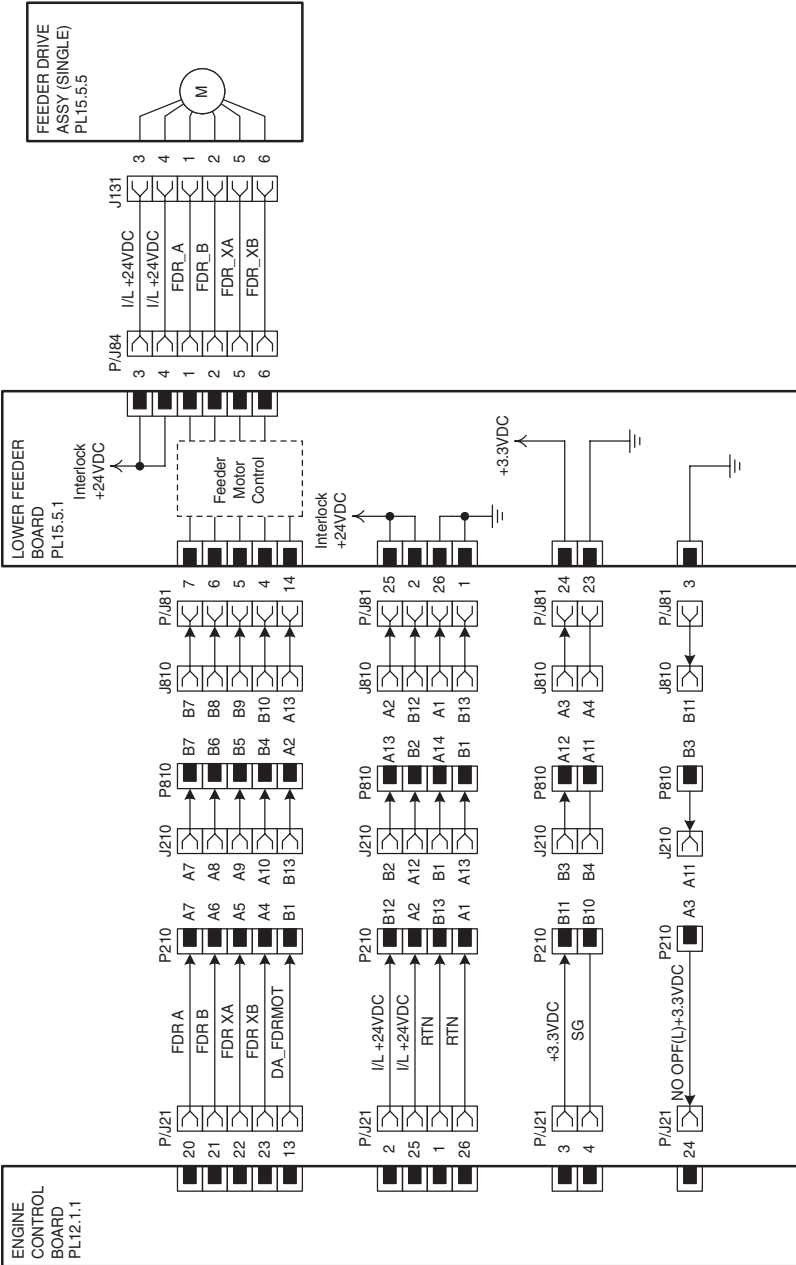

Paper Tray 3

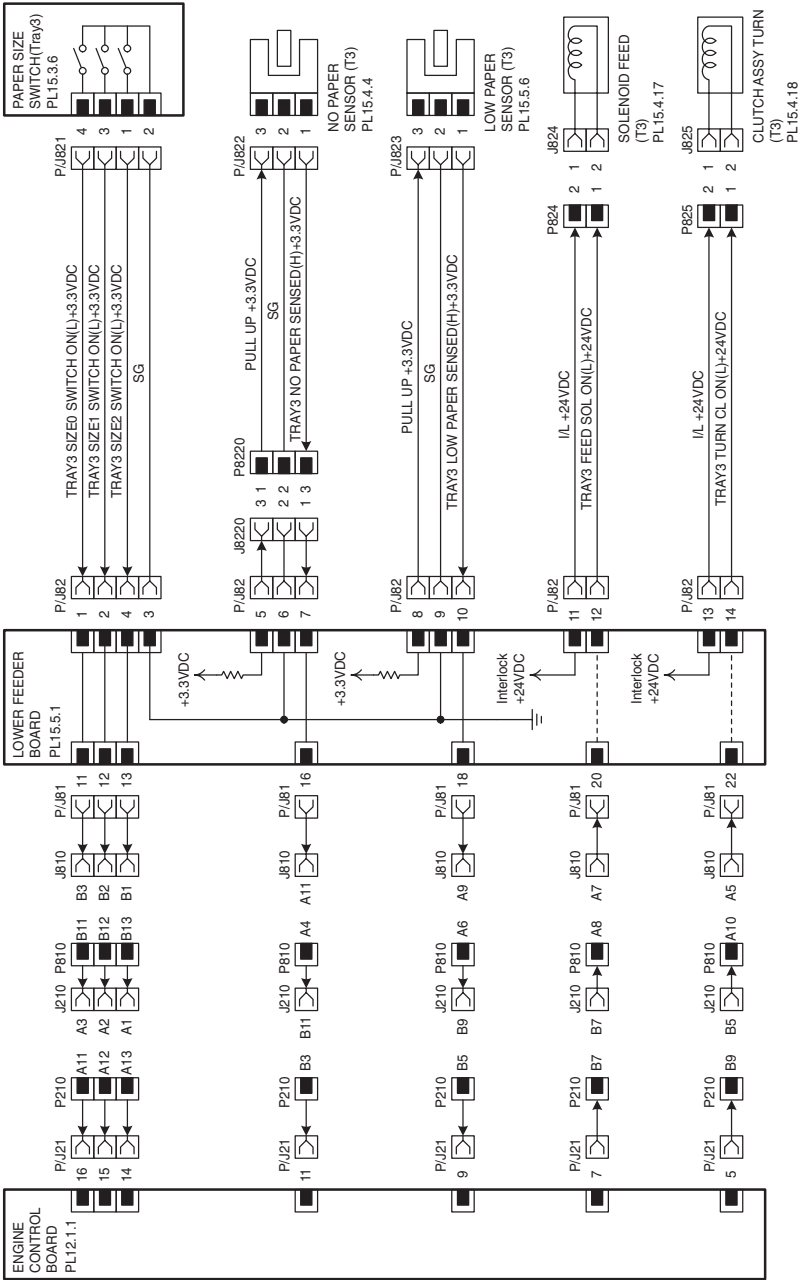

6250-434

Reference

Contents...

- Printer Status Codes

Appendix A

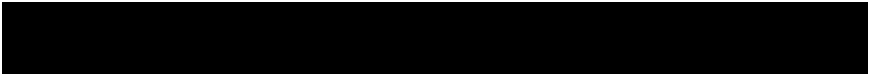

Printer Status Codes

Printer status codes that appear in the Service Usage Profile are defined in the following table. The code listings are generally in numerical order although some errors without assigned codes are interspersed in the list. Refer to the "Error Messages and Codes Summary Table" on page 3-17 for additional information.

ServiceCode	Description
7	Laser Failure 7
8	Laser Failure 8
9	Laser Failure 9
10	Laser Failure 10
11	Laser Failure 11
13	Density Sensor Failure 13
14	Density Sensor Failure 14
15	Density Sensor Failure 15
16	Density Sensor Failure 16
40	Fuser Failure 40
41	Fuser Failure 41
42	Fuser Failure 42
43	Fuser Failure 43
44	Fuser Failure 44
45	Fuser Failure 45
46	Fuser Failure 46
47	Fuser Failure 47
50	Fuser Fan Failure
51	Rear Fan Failure
52	Fan Failure
70	Engine Firmware Failure 70
71	Engine Firmware Failure 71
72	Engine Firmware Failure 72
73	Engine Firmware Failure 73
74	Engine Firmware Failure 74
75	Imaging Unit Firmware Failure
76	Fuser Firmware Failure
77	Engine Firmware Failure 77
78	Engine Firmware Failure 78
79	Engine Firmware Failure 79

81	Engine Communication Failure
83	Engine NVRAM Failure
86	Cyan Toner Cartridge Failure
87	Magenta Toner Cartridge Failure
88	Yellow Toner Cartridge Failure
89	Black Toner Cartridge Failure
90	Replace Cyan Toner Cartridge
91	Replace Magenta Toner Cartridge
92	Replace Yellow Toner Cartridge
93	Replace Black Toner Cartridge
94	Non-Phaser 6250 Fuser
95	Non-Xerox Imaging Unit
96	Replace Non-Xerox Cyan Toner Cartridge
97	Replace Non-Xerox Magenta Toner Cartridge
98	Replace Non-Xerox Yellow Toner Cartridge
99	Replace Non-Xerox Black Toner Cartridge
102	Environment Sensor Failure
150	Close Front Door
151	Dusty Density Sensor
152	Jam at Fuser
153	Jam at Duplex
154	Jam at Registration Roller
155	Misfeed at Tray [1(MPT)]
156	Misfeed at Tray [2]
157	Misfeed at Tray [3]
158	Misfeed at Tray [4]
159	Insert Tray [2]
160	Insert Tray [3]
161	Insert Tray [4]
162	Out of paper: Load Tray [1(MPT)] with [size] [type]
163	Out of paper: Load Tray [2] with [size] [type]
164	Out of paper: Load Tray[3] with [size] [type]
165	Out of paper: Load Tray [4] with [size] [type]
166	Wrong paper size: Load Tray [1(MPT)] with [size] [type]
167	Wrong paper size: Load Tray [2] with [size] [type]
168	Wrong paper size: Load Tray [3] with [size] [type]
169	Wrong paper size: Load Tray [4] with [size] [type]
170	Wrong paper type: Load Tray [1(MPT)] [2] [3] [4] with [size] [type]
171	Wrong paper type: Load Tray [1(MPT)] with [size] [type]

172	Wrong paper type: Load Tray [2] with [size] [type]
173	Wrong paper type: Load Tray [3] with [size] [type]
174	Paper not available: Load Tray [4] with [size] [type]
178	Output Tray Full
179	Cyan Toner Cartridge Empty
180	Magenta Toner Cartridge Empty
181	Yellow Toner Cartridge Empty
182	Black Toner Cartridge Empty
183	Replace Cyan Toner Cartridge
184	Replace Magenta Toner Cartridge
185	Replace Yellow Toner Cartridge
186	Replace Black Toner Cartridge
189	Replace Fuser
190	Replace Imaging Unit
191	Replace Transfer Roller
192	Install or Lock Cyan Toner Cartridge
193	Install or Lock Magenta Toner Cartridge
194	Install or Lock Yellow Toner Cartridge
195	Install or Lock Black Toner Cartridge
196	Install or Reseat Imaging Unit
197	Install or Reseat Transfer Roller
198	Install or Reseat Fuser
199	Remove Ribbon From Cyan Toner Cartridge
200	Remove Ribbon From Magenta Toner Cartridge
201	Remove Ribbon From Yellow Toner Cartridge
202	Remove Ribbon From Black Toner Cartridge
203	The Cyan Toner Cartridge is not a genuine Xerox product
204	The Magenta Toner Cartridge is not a genuine Xerox product
205	The Yellow Toner Cartridge is not a genuine Xerox product
206	The Black Toner Cartridge is not a genuine Xerox product
207	Cyan Toner Cartridge Empty
208	Magenta Toner Cartridge Empty
209	Yellow Toner Cartridge Empty
210	Replace Cyan Toner Cartridge t
211	Replace Magenta Toner Cartridge
212	Replace Yellow Toner Cartridge
213	Replace Black Toner Cartridge

Index

Numerics

600 x 600 Service Test Print, 5-8

A

AC Power Supply Troubleshooting, 4-13

AC Switch Harness Assembly, 8-98

Actuator, I/L, 8-96

Adjustments, 6-3

B

Background Contamination, 5-20

Bias Housing Assembly, 8-69

Black Prints with White Margin Border,
5-14

Blank Prints, 5-13

C

, 3-54

Calibrations, 6-2

Card Cage, 8-103

Casters, Locking/Non-Locking, 8-129

Chute Assembly Exit, 8-62, 9-22

Chute Assembly In, 8-41, 9-16

Chute Assembly Out, 9-18

Chute Assembly Out, Duplex, 8-47

Chute Assembly Registration, 8-71

Chute Assembly Registration (REGI),
2-32

Chute Assembly, Exit, 2-30

Chute Assembly, In, 2-28

Chute Assembly, Out (Duplex), 2-29

Circuit Board, HCF, 8-116

Circuit Board, STF, 8-135

Cleaning, 7-2

cleaning the printer, 7-2

Close Front Door, 3-41

CMYK Sample Page, 5-4

Color Calibration, 6-2

Color Registration, 6-3

Color Registration Control, 2-9

Consumable Life Counter Behavior, 1-10

Consumables, 1-9

Controller to Engine Communications

Failure, 3-79

Cover Front, 8-130

Cover, Right and Cover, Left STF, 8-131

Covers, 9-4

CRUM ID Toner Error, 3-81

CRUM Reader Box Assembly, 8-85

CTD (ADC) Sensor, 8-42

D

DC Power Supply Troubleshooting, 4-13

Defects Associated with Specific Printer
Components, 5-3

Density Sensor Failure or Low Density
Failure, 3-69

Developer Assembly Transmission
Route, 2-40

Developer Drive Assembly, 8-95

Developer Section 1, 10-19

Developer Section 2, 10-20

Diagnostic Menu Map, 3-8

Disassembly, General Notes, 8-3

Drive Feeder Assembly, 8-117, 8-136

Drive Section, 10-18

Drive Section (HCF), 10-28

Drive Section (STF), 10-32

Duplex Actuator, 8-51

Duplex Motor Assembly, 8-65

Duplex Motor Drive and Gear -
Transmission Route, 2-31

Duplex Sensor, 8-51

Dusty Density Sensor, 3-52

E

Earth Ground Circuit Board, 8-97
EEPROM Board, 8-85
Electrical, 2-41, 9-32
Electrical Specifications, 1-13
Electrostatic Discharge (ESD)
Precautions, 1-vii
Engine Control Circuit Board, 8-107
Engine Firmware Failure, 3-76
Engine NVRAM Error, 3-80
Engine Power-Up Sequence, 4-9
Environmental Sensor Failure, 3-85
Environmental Specifications, 1-13
Error Messages and Codes Summary
Table, 3-17
Exit Actuator (Fuser), 8-66
Exit Roller, 8-63

F

Fault Isolation, 4-9
Feed Solenoid, 8-33
Feeder Assembly Unit, 8-23
Feeder Cover Front, 8-111
Feeder Covers, Right and Left, 8-112
Feeder Turn Chute Assembly, 8-113
Frame and Drive Assemblies, 2-16, 9-30
Friction Clutch Assembly, 8-38
Front Cover, 8-6
Front Left Cover Assembly, 8-16
Front Panel, 8-7
Front Panel Continually Displays "Install
or Reseat Imaging Unit", 4-8
Front Panel Continually Displays
"Warming Up...", 4-8
Front Panel LED is on, Front Panel
Display is Blank, 4-8
Front Panel Test Prints, 5-4
Front Panel Troubleshooting, 4-8
Front Right Cover, 8-15
Full Stack Sensor, 8-50
Functional Specifications, 1-12
Fuser Assembly, 10-21
Fuser Control, 2-13
Fuser Drive Assembly, 8-44
Fuser Drive Assembly - Transmission

Route, 2-34
Fuser Failure, 3-70
Fuser Fan, 8-8
Fuser Fan Failure, 3-73
Fuser Firmware Failure, 3-78
Fuser Removal, 8-5

G

Gear Layout - Print Engine and Tray 1,
2-18
General Notes on Disassembly, 8-3
General Notes on Troubleshooting, 3-4
Generic Fan Failure, 3-75

H

Harness Assemblies, 9-34
HCF Drive and Gears - Transmission
Route, 2-25, 2-26
HCF Paper Pick Assembly, 8-125
High Capacity Feeder Main Wiring
Diagram, 10-27
High-Capacity Feeder Covers, 9-37
High-Capacity Feeder Guides and Turn
Chute Assembly, 9-38
High-Capacity Feeder Harness, 8-25
High-Capacity Feeder Harness, Board
and Motor, 9-42
High-Capacity Feeder Plug/Jack Locator
Table, 10-10
Holder Toner Cartridge Assembly, 9-28
Housing Assembly Bias, 8-69
Housing Assembly Contact, 8-106
Housing Assembly Electric, 8-71
Housing Assembly Retard, 9-14
Housing Electric Assembly, 8-71

I

Idler Gear, 8-126
Image Processor Board, 1-8, 8-110,
10-26
Image Unit Top Cover (Door C), 8-10
Imaging Unit Charge Voltage Contacts,
2-36

Imaging Unit Firmware Failure, 3-77
Imaging Unit is at End of Life, 3-43
Imaging Unit Removal, 8-4
Incomplete Fusing or Cold Offset, 5-23
Indicator Assembly, 8-137
Indicator Assembly, Feeder, 8-118
Inoperable Printer Troubleshooting, 4-9
Insert Tray or Tray Missing, 3-55, 3-57
Install or Lock Toner Cartridge, 3-48
Install or Reseat Fuser, 3-46
Install or Reseat Imaging Unit, 3-42
Install or Reseat Transfer Roller, 3-44
Introduction, 4-2

J

Jam at Duplex or Jam D, 3-21
Jam at Fuser or Jam F, 3-19
Jam at Registration Roller or Jam RR,
3-23, 3-28
Jam History Error Codes Table, 3-16

K

, 3-54

L

Laser Failure, 3-68
Laser Light Intensity Control, 2-6
Laser Unit, 8-68, 10-22
Latch Holder, 8-57
Latch L, 8-46
Latch Plate, 8-57
Latch R (Door A), 8-45
Latch Spring Out, 8-57
LED Blink Patterns, 4-6
LED Light Density CTD (ADC) Control
of Sensor, 2-8
Left and Right Links, 8-13
Left Side Cover, 8-11
Left Tray Guide, 8-141
Left Tray Guide, Feeder, 8-122
Lever Plate Right, 8-91
Light Print in Only One Color, 5-11
Light Prints, 5-10

Link Actuator, 8-32, 8-124, 8-143
Load Tray 1 with (size) (type), 3-63
Load Tray with (size) (type), 3-65, 3-67
Low Paper Indicator, 8-27
Low Paper Indicator Guide, 8-27
Low Paper Lever, 8-27
Low-Voltage Power Supply, 8-99

M

, 3-54
Macintosh printing problems, 4-18
Main Drive Assembly, 8-94
Main Drive Assembly - Transmission
Route, 2-17
Main Wiring Diagram, 10-15
Major Assemblies and Functions, 2-16
Manual Terms, 1-iv
Map 1, 10-6
Map 2, 10-7
Map 3, 10-8
Map 4, 10-9
Map 5, 10-11
Map 6, 10-13
Margin Calibration, 6-2
Media and Tray Specifications, 1-14
Media Jams and the Paper Path, 4-15
Mid Roller, 8-64
Misfeed at Tray 1 (MPT) or Jam T0, 3-30
Misfeed at Tray 2 or Jam T1, 3-33
Misfeed at Tray 3 or Jam T2, 3-36
Misfeed at Tray 4 or Jam T3, 3-39
Mis-Registration, Color Layer not
Correctly Registered, 5-24
Missing Band, Voids Or Streaks, 5-16
Missing Band, Voids or Streaks, 5-18
Motor Control Circuit Board, 8-107
Motor Driver Board, 8-101
MPT Paper Pick Assembly, 8-58

N

Network Problems, 4-20
No Front Panel Display after Power is
Turned ON, 4-8
No Paper Actuator, 8-30

No Paper, Low Paper Sensor, 8-127,
8-145

No/Low Paper Sensor, 8-30

Non-Phaser 6250 Fuser, 3-83

Non-Xerox Imaging Unit, 3-84

O

Operating System and Application
Problems, 4-18

Optional High Capacity Feeder
Disassembly, 8-111

Optional High-Capacity Feeder, 9-36

Optional Single Tray Feeder, 9-44

Optional Single Tray Feeder
Disassembly, 8-130

Output Tray Full Actuator, 8-50

Output Tray is Full, Unload Paper, 3-53
Overview, 8-2

Overview of Printer Theory of Operation,
2-2

P

Paper Feed, 10-25

Paper Feed - Tray 2, 2-20

Paper Feed I, 9-8

Paper Feed II, 9-10

Paper Feed III, 9-12

Paper Feed Roller, Feeder, 8-36

Paper Feed Roller, Tray, 8-18

Paper Path of the Printer, 2-14

Paper Path Route, 2-15

Paper Pick, 2-6

Paper Pick Assembly, 8-22

Paper Pick Assembly Tray 3, 9-48

Paper Pick Assembly Trays 3 & 4, 9-40

Paper Pick Rollers, 8-29

Paper Size Control, 2-5

Paper Size Switch Assembly, 4-11, 8-26,
8-128, 8-146

Paper Tray 2, 2-19, 10-17

Paper Tray 3, 9-44, 10-29, 10-33

Paper Tray 4, 10-30

Paper Trays 3 & 4, 9-36

Parts of the Printer, 1-5

Phaser 6250 Front Panel Configuration,
1-6

Physical Dimensions and Clearances,
1-11

Plug/Jack Locator Maps, 10-2

POST Diagnostic Test Descriptions, 4-7

POST Faults, 4-6

PostScript NVRAM Resets, 6-4

Power, 4-2

Power On Self Test (POST), 4-4

Power Safety Precautions, 1-vi

Power Supplies, 10-16

Power Supply, 4-12

Power-Up Modes, 4-2

preventive maintenance, 7-2

Print Engine Disassembly, 8-6

Print Engine Parts, 9-4

Print Engine Test Print, 5-9

Print Engine Wiring Diagrams, 10-14

Print Modes, 2-5

Print Quality Troubleshooting, 5-10

Printer Chassis, 8-20

Printer Configurations, 1-2

Printer Controls, 2-5

Printer Does Not Come to a "Ready"

State, 4-9, 4-10

Printer Introduction and Overview, 1-2

Printer Memory and RAM Capabilities,
1-4

Printer Options Wiring Diagrams, 10-27

Printer Specifications, 1-11

Printer Status Page, 4-2

Print-Quality Problems Overview, 5-2

Process Control, 2-6

Product Terms, 1-iv

R

Rear Cover, 8-12

Rear Fan, 8-102

Rear Fan Failure, 3-74

Registration Sensor, 8-73

Registration Sensor Actuator, 8-73

Regulatory Specifications, 1-x

Removal - Actuator, Output Tray Full,
8-50

Removal - Full Stack Sensor, 8-50
 Removing RMIs and Consumables, 8-4
 Removing Routine Maintenance Items and Consumables, 8-4
 Removing the Duplex Actuator, 8-51
 Repeating and/or Random Spots, 5-19
 Replace Fuser or Fuser is at End of Life, 3-47
 Replace Imaging Unit, 3-43
 Replace Toner Cartridge or Toner Cartridge Empty, 3-50
 Replace Transfer Roller, 3-45
 Resetting NVRAM, 6-4
 Residual Image, Ghosting or Hot Offset, 5-22
 Retard Housing Assembly, 2-27
 Retard Roll Assembly, 8-39
 Retard Roller Housing Assembly, 8-37
 RGB Test Print, 5-5
 Right and Left Covers, Feeder, 8-131
 Right Side Cover, 8-11
 Right Tray Guide, 8-138
 Right Tray Guide Feeder, 8-119
 Roll Turn Assembly, 8-35
 Routine Maintenance Items, 1-9
 Service Test Prints, 5-6
 Servicing Instructions, 3-3
 Single Tray Feeder Covers, 9-45
 Single Tray Feeder Guides and Turn Chute Assembly, 9-46
 Single Tray Feeder Harness, Board and Motor, 9-50
 Single Tray Feeder Main Wiring Diagram, 10-31
 Single Tray Feeder Plug/Jack Locator Table, 10-12
 Solid Dark or Dirty Prints, No Border, 5-15
 Specifications
 regulatory, 1-x
 Standard Orientation of the Printer, 8-2
 Static Eliminator Assembly, 8-55
 STF Paper Pick Assembly, 8-144
 Strap, 8-67
 Sub-High Voltage Power Supply Board, 8-87
 Summary of the Printing Process, 2-2
 Symbols Marked on the Product, 1-v
 Symbols, on product, 1-v
 System Boot Sequence, 4-3
 System Start-Up and POST, 4-3

S

Safety

- electrical components, 1-ix
- fuser components, 1-ix
- mechanical components, 1-ix
- Power, 1-vi
- power source, 1-vi
- service summary, 1-viii

Selective Control, 2-6
 Serial Number Format, 9-2
 Service Diagnostic Front Panel Button Descriptions, 3-7
 Service Diagnostic Tests, 3-9
 Service Diagnostics, 3-6
 Service Diagnostics PostScript NVRAM Resets, 6-8
 Service Preventive Maintenance Procedure, 7-2
 Service Safety Summary, 1-viii

T

Temperature/Humidity Harness and Sensor, 8-24
 Test Pattern Sample, 5-6
 Toner Cartridge, 3-54
 Toner Cartridge Assembly, 2-38
 Toner Cartridge Failure, 3-82
 Toner Cartridge Holder Assembly, 8-80
 Toner Cartridge Holder Unit Assembly, 8-77
 Toner Cartridge Removal, 8-5
 Toner Control, 2-12
 Toner Full Sensor, 8-43
 Toner Low Sensor, 8-84
 Toner Motor Drive Assembly - Transmission Route, 2-40
 Top Main Cover, 8-9
 Transfer Roller & Fuser Assembly

(RMIs), 9-24
Transfer Roller and Fuser Assembly, 2-33
Transfer Roller Assembly Control, 2-11
Transfer Roller is at End of Life, 3-45
Transfer Roller Removal, 8-4
Tray 1 (MPT), 8-14
Tray 1 Actuator, 8-53
Tray 1 Bottom Plate, 8-61
Tray 1 Feed Solenoid, 8-59
Tray 1 Paper Pick Assembly, 8-58
Tray 1 Paper Pick Assembly (PL 6.1.27), 8-58
Tray 1 Sensor, 8-53
Tray 1 Shaft, 8-60
Tray 3 and Tray 4 Harness, 8-114
Tray 3 Harness Assembly, 8-133
Tray Empty, Load Paper, 3-62
Tray Paper is Low, 3-59, 3-60
Turn Chute Assembly, 8-19, 8-132
Turn Clutch, 8-38
Turn Clutch Assembly, 8-34
Turn Roll, 8-38

U

Universal Paper Tray, 9-7
Using the Parts List, 9-3
Using the Troubleshooting Procedures, 3-4

V

Voltage Measurements, 3-5

W

Windows printing problems, 4-20
Wrong, 3-63, 3-65, 3-67

X

Xerographics, 2-35, 9-26
Xerographics 1, 10-23
Xerographics 2, 10-24
Xerox Supplies and Accessories, 9-51

Y

Remove Ribbon from, 3-54

