

Phaser® 6300/6350

XEROX®



color laser printer

Service Manual



Phaser[®] 6300/6350 Color Laser Printer

Service Manual

Warning

The following servicing instructions are for use by qualified service personnel only. To avoid personal injury, do not perform any servicing other than that contained in the operating instructions, unless you are qualified to do so.

First Printing: March 2005

071-0875-00



Service Terms

Manual Terms

Various terms are used throughout this manual to either provide additional information on a specific topic or to warn of possible danger present during a procedure or action. Be aware of all symbols and terms when they are used, and always read NOTE, CAUTION, and WARNING statements.

Common Acronyms:

The following list defines the acronyms that may be found in this manual.

| | |
|--|---|
| ADC: Automatic Density Control | MCU: Engine Control Board |
| BTR: Bias Transfer Roller | NCS: Non-Contact Sensor |
| CRUM: Customer Replaceable Unit Monitor | PHD: Imaging Unit |
| CTD: Toner Density Control | PL: Corresponds to the FRU Parts List. |
| ESD: Electrostatic Discharge | ROS: Laser Scanning Unit |
| IDT: Intermediate Transfer Unit | RTC: Charge Roller |

Note

A note indicates an operating or maintenance procedure, practice or condition that is necessary to efficiently accomplish a task.

A note can provide additional information related to a specific subject or add a comment on the results achieved through a previous action.

Caution

A caution indicates an operating or maintenance procedure, practice or condition that, if not strictly observed, results in damage to, or destruction of, equipment.

Warning

A warning indicates an operating or maintenance procedure, practice or condition that, if not strictly observed, results in injury or loss of life.

Product Terms

Caution: A personal injury hazard exists that may not be apparent. For example, a panel may cover the hazardous area.

Danger: A personal injury hazard exists in the area where you see the sign.

Symbols Marked on the Product

DANGER high voltage.



Protective ground (earth) symbol.



Hot surface on or in the printer. Use caution to avoid personal injury.



The surface is hot while the printer is running. After turning off the power, wait 30 minutes.



Avoid pinching fingers in the printer. Use caution to avoid personal injury.



Use caution (or draws attention to a particular component). Refer to the manual(s) for information.



Power Safety Precautions

Power Source

For 115 VAC printers, do not apply more than 135 volts RMS between the supply conductors or between either supply conductor and ground. For 230 VAC printers, do not apply more than 254 volts RMS between the supply conductors or between either supply conductor and ground. Use only the specified power cord and connector. This manual assumes that the reader is a qualified service technician.

Plug the three-wire power cord (with grounding prong) into a grounded AC outlet only. If necessary, contact a licensed electrician to install a properly grounded outlet. If the product loses its ground connection, contact with conductive parts may cause an electrical shock. A protective ground connection by way of the grounding conductor in the power cord is essential for safe operation.

Disconnecting Power

Warning

Turning the power off using the power switch does not completely de-energize the printer. You must also disconnect the power cord from the printer's AC inlet. Disconnect the power cord by pulling the plug, not the cord.

Disconnect the power cord in the following cases:

- if the power cord or plug is frayed or otherwise damaged,
- if any liquid or foreign material is spilled into the product,
- if the printer is exposed to any excess moisture,
- if the printer is dropped or damaged,
- if you suspect that the product needs servicing or repair,
- whenever you clean the product.

Electrostatic Discharge (ESD) Precautions

Some semiconductor components, and the respective sub-assemblies that contain them, are vulnerable to damage by Electrostatic discharge (ESD). These components include Integrated Circuits (ICs), Large-Scale Integrated circuits (LSIs), field-effect transistors and other semiconductor chip components. The following techniques will reduce the occurrence of component damage caused by static electricity.

Be sure the power is off to the chassis or circuit board, and observe all other safety precautions.

- Immediately before handling any semiconductor components assemblies, drain the electrostatic charge from your body. This can be accomplished by touching an earth ground source or by wearing a wrist strap device connected to an earth ground source. Wearing a wrist strap will also prevent accumulation of additional bodily static charges. Be sure to remove the wrist strap before applying power to the unit under test to avoid potential shock.
- After removing a static sensitive assembly from its anti-static bag, place it on a grounded conductive surface. If the anti-static bag is conductive, you may ground the bag and use it as a conductive surface.
- Do not use freon-propelled chemicals. These can generate electrical charges sufficient to damage some devices.
- Do not remove a replacement component or electrical sub-assembly from its protective package until you are ready to install it.
- Immediately before removing the protective material from the leads of a replacement device, touch the protective material to the chassis or circuit assembly into which the device will be installed.
- Minimize body motions when handling unpacked replacement devices. Motion such as your clothes brushing together, or lifting a foot from a carpeted floor can generate enough static electricity to damage an electro-statically sensitive device
- Handle IC's and EPROM's carefully to avoid bending pins.
- Pay attention to the direction of parts when mounting or inserting them on Printed Circuit Boards (PCB's).

Service Safety Summary

General Guidelines

For qualified service personnel only: Refer also to the preceding Power Safety Precautions.

Avoid servicing alone: Do not perform internal service or adjustment of this product unless another person capable of rendering first aid or resuscitation is present.

Use care when servicing with power: Dangerous voltages may exist at several points in this product. To avoid personal injury, do not touch exposed connections and components while power is on. Disconnect power before removing the power supply shield or replacing components.

Do not wear jewelry: Remove jewelry prior to servicing. Rings, necklaces and other metallic objects could come into contact with dangerous voltages and currents.

Warning Labels

Read and obey all posted warning labels. Throughout the printer, warning labels are displayed on potentially dangerous components. As you service the printer, check to make certain that all warning labels remain in place.

Safety Interlocks

Make sure all covers are in place and all interlock switches are functioning correctly after you have completed a printer service call. If you bypass an interlock switch during a service call, use extreme caution when working on or around the printer.

CLASS 1 LASER PRODUCT

The Phaser® 6300/6350 Color Laser Printer is certified to comply with Laser Product Performance Standards set by the U.S. Department of Health and Human Services as a Class 1 Laser Product. This means that this product does not emit hazardous laser radiation; which is possible only because the laser beam is totally enclosed during all modes of customer operation. When servicing the printer or laser unit, follow the procedures specified in this manual and there will be no hazards from the laser.

Servicing Electrical Components

Before starting any service procedure, switch off the printer power and unplug the power cord from the wall outlet. If you must service the printer with power applied, be aware of the potential for electrical shock.

Warning

Do not touch any electrical component unless you are instructed to do so by a service procedure.

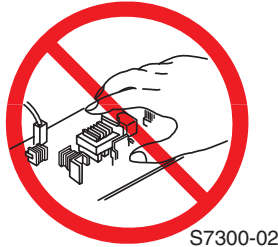

Servicing Mechanical Components

When servicing mechanical components within the printer, manually rotate drive assemblies, rollers, and gears.

Warning

Do not try to manually rotate or manually stop the drive assemblies while any printer motor is running.

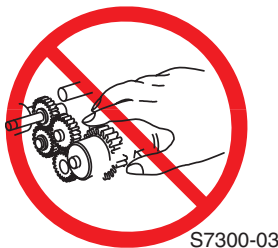

Servicing Fuser Components

Warning

This printer uses heat to fuse the toner image to media. The Fuser is VERY HOT. Turn the printer power off and wait at least 5 minutes for the Fuser to cool before you attempt to service the Fuser or adjacent components.

Regulatory Specifications

Xerox has tested this product to electromagnetic emission and immunity standards. These standards are designed to mitigate interference caused or received by this product in a typical office environment.

United States (FCC Regulations)

This equipment has been tested and found to comply with the limits for a Class B digital device, pursuant to Part 15 of the FCC Rules. These limits are designed to provide reasonable protection against harmful interference in a residential installation. This equipment generates, uses, and can radiate radio frequency energy. If it is not installed and used in accordance with these instructions, it may cause harmful interference to radio communications. However, there is no guarantee that interference will not occur in a particular installation. If this equipment does cause harmful interference to radio or television reception, which can be determined by turning the equipment off and on, the user is encouraged to try to correct the interference by one or more of the following measures:

- Reorient or relocate the receiver (device being interfered with).
- Increase the separation between the printer and the receiver.
- Connect the equipment into an outlet on a circuit different from that which the receiver is connected.
- Consult the dealer or an experienced radio/television technician for help.

Any changes or modifications not expressly approved by Xerox could void the user's authority to operate the equipment. To ensure compliance with Part 15 of the FCC rules, use shielded interface cables.

Canada (Regulations)

This Class B digital apparatus complies with Canadian ICES-003.

Cet appareil numérique de la classe B est conforme à la norme NMB-003 du Canada.

European Union

Xerox Corporation declares, under our sole responsibility, that the product to which this declaration relates is in conformity with the following standards and other normative documents:

Low Voltage Directive 73/23/EEC as amended

EN 60950:2000

EN 60825-1:1994+A1:2001+A2:2002

Electromagnetic Compatibility Directive 89/336/EEC as amended

EN 55022:1998 +A1:2000 +A2:2003

EN 55024:1998 +A1:2000 +A2:2003

EN 61000-3-2:2000

EN 61000-3-3:1995 +A1:2001

Radio & Telecommunications Terminal Equipment Directive 1999/5/EC as amended

EN 300 330-2 V1.1.1

EN 300 440-2 V1.1.1

EN 300 489-3 V1.3.1

This product, if used properly in accordance with the user's instructions, is neither dangerous for the consumer nor for the environment.

A signed copy of the Declaration of Conformity for this product can be obtained from Xerox.

Manual Organization

The *Phaser 6300/6350 Color Laser Printer Service Manual* is the primary document used for repairing, maintaining, and troubleshooting the printer. Use this manual as your primary resource for understanding the operational characteristics of the printer and all available options. This manual describes specifications, theory, and the diagnosis and repair of problems occurring in the print engine and attached options. Also included are detailed replacement procedures, parts lists, and wiring diagrams.

The *Phaser 6300/6350 Color Laser Printer Service Manual* contains these sections:

Introductory, Safety, and Regulatory Information: This section contains important safety information and regulatory requirements.

Section 1 - General Information: This section contains an overview of the printer's operation, configuration, specifications, and consumables.

Section 2 - Theory of Operation: This section contains detailed functional information on print engine components.

Section 3 - Error Codes and Messages: This section provides detailed troubleshooting procedures for error messages and codes generated by resident diagnostics.

Section 4 - General Troubleshooting: Troubleshooting discussions cover the operation of Power On Self Test (POST), Service Diagnostics, In addition, this section includes troubleshooting methods for situations where no error indicator is available.

Section 5 - Print-Quality Troubleshooting: This section focuses on techniques to correct image quality problems associated with printer output.

Section 6 - Adjustments and Calibrations: This section provides procedures for the adjustment of print engine components.

Section 7 - Cleaning and Maintenance: This section provides periodic cleaning procedures for the printer.

Section 8 - Service Parts Disassembly: This section contains removal procedures for spare parts listed in the Parts List. A replacement procedure is included when necessary.

Section 9 - Parts List: This section contains exploded views of the print engine and option FRUs, as well as part numbers for orderable parts.

Section 10 - Wiring Diagrams: This section contains the plug/jack locations and the wiring diagrams for the print engine.

Appendix A - Reference: This section provides an illustration of the printer's menu structure, a listing of printer status codes, and a list of Service Diagnostics tests.

Contents

| | |
|---|-----|
| Service Terms | iii |
| Symbols Marked on the Product | iv |
| Power Safety Precautions | v |
| Electrostatic Discharge (ESD) Precautions | vi |
| Service Safety Summary | vii |
| Regulatory Specifications | ix |
| Manual Organization | xi |

1 General Information

| | |
|---|------|
| Printer Introduction and Overview | 1-2 |
| Printer Configurations | 1-3 |
| Metered Printing | 1-4 |
| Parts of the Printer | 1-5 |
| Control Panel | 1-6 |
| Rear Panel | 1-7 |
| Image Processor Board | 1-7 |
| Printer Options | 1-8 |
| Hard Drive | 1-8 |
| Additional Memory | 1-8 |
| Configuration Card | 1-8 |
| 550-Sheet Feeder | 1-9 |
| 1100-Sheet Feeder | 1-9 |
| Maintenance Items | 1-10 |
| Consumables | 1-11 |
| Consumable Life Counter Behavior | 1-11 |
| Specifications | 1-12 |
| Memory Specifications | 1-12 |
| Electrical Specifications | 1-12 |
| Physical Dimensions and Clearances | 1-13 |
| Functional Specifications | 1-14 |
| Image Specifications | 1-15 |
| Imaging Unit Cleaning Cycle Intervals | 1-15 |
| Environmental Specifications | 1-16 |
| First Print Output Time | 1-16 |
| Media and Tray Specifications | 1-17 |

2 Theory of Operation

| | |
|---|-----|
| Phaser 6300/6350 Operational Overview | 2-2 |
| Summary of the Printing Process | 2-3 |
| Print Process Components | 2-5 |
| Print-Quality Modes | 2-6 |

| | |
|--|------|
| Printer Controls | 2-7 |
| Paper Size Control | 2-7 |
| Selective Control; Paper Pick | 2-7 |
| Laser Light Intensity Control | 2-8 |
| Process Control | 2-9 |
| LED Light Density CTD (ADC) Control Sensor | 2-11 |
| Color Registration Control | 2-12 |
| Transfer Roller Control | 2-13 |
| Toner Control | 2-14 |
| Fuser Control | 2-15 |
| Paper Path of the Printer | 2-16 |
| Paper Path Route | 2-17 |
| Sensors | 2-18 |
| Sensor Types | 2-18 |
| Sensors in the Paper Path | 2-19 |
| Print Engine Assemblies | 2-22 |
| Drive Assemblies | 2-22 |
| Registration Roller Assembly | 2-30 |
| Chute Assembly In | 2-33 |
| Chute Assembly Out | 2-34 |
| Transfer Roller and Fuser Assembly | 2-37 |
| Tray 1 (MPT) | 2-39 |
| Tray 2 | 2-40 |
| Tray 2 Paper Pick Assembly | 2-41 |
| Xerographics | 2-43 |
| Toner Cartridge Holder Assembly | 2-45 |
| Electrical | 2-48 |
| 1100-Sheet Feeder Assemblies | 2-50 |
| Paper Pick Assemblies | 2-51 |
| Electrical | 2-52 |
| Drive | 2-53 |
| Drive Gears | 2-54 |
| 550-Sheet Feeder Assemblies | 2-55 |
| Tray 3 Feeder | 2-56 |
| Electrical | 2-57 |
| Drive | 2-58 |
| Drive Gears | 2-59 |

3 Error Messages and Codes

| | |
|-----------------------------------|-----|
| Introduction | 3-2 |
| Accessing Fault History | 3-2 |
| Status Page | 3-3 |
| Service Usage Profile | 3-3 |
| Servicing Instructions | 3-4 |

| | |
|--|------|
| Messages, Codes, and Procedures | 3-5 |
| Error Message Abbreviations | 3-5 |
| Error Message Summary | 3-6 |
| Using the Troubleshooting Procedures | 3-9 |
| Measurement Techniques | 3-9 |
| Jam Error Procedures | 3-11 |
| Jam at Fuser: Jam F | 3-11 |
| Jam at Duplex: Jam D | 3-13 |
| Jam at Registration Roller: Jam RR | 3-15 |
| Misfeed at Tray 1 (MPT): Jam T1 | 3-17 |
| Misfeed at Tray 2: Jam T2 | 3-20 |
| Misfeed at Tray 3: Jam T3 | 3-23 |
| Misfeed at Tray 4: Jam T4 | 3-26 |
| Misfeed at Tray 5: Jam T5 | 3-29 |
| Door and Cover Error Procedures | 3-31 |
| Close Front Door | 3-31 |
| Consumable/Routine Maintenance Procedures | 3-33 |
| Install or Reseat Imaging Unit | 3-33 |
| Replace Imaging Unit or | |
| Imaging Unit Is Near End of Life | 3-34 |
| Install or Reseat Transfer Roller | 3-35 |
| Replace Transfer Roller or | |
| Transfer Roller Is at End of Life | 3-37 |
| Install or Reseat Fuser | 3-38 |
| Replace Fuser | 3-39 |
| Install or Lock [Y] [M] [C] [K] Toner Cartridge | 3-41 |
| Replace [Y] [M] [C] [K] Toner Cartridge or | |
| [Y] [M] [C] [K] Toner Is Low | 3-42 |
| Dusty Density Sensor | 3-44 |
| Remove Ribbon from [Y] [M] [C] [K] Toner Cartridge | 3-45 |
| Tray 2 Paper Is Low | 3-46 |
| Tray [3] [4] [5] Paper Is Low | 3-47 |
| Replace [Y] [M] [C] [K] Toner Cartridge | 3-48 |
| Non-Phaser 6300/6350 Fuser | 3-50 |
| Replace Maintenance Kit | 3-51 |
| Non-Xerox Imaging Unit | 3-52 |
| Metered Toner Is not Enabled | 3-53 |
| Tray and Media Errors | 3-54 |
| Insert Tray [2] or Tray [2] Missing | 3-54 |
| Insert Tray [3] [4] [5] or Tray [3] [4] [5] Missing | 3-55 |
| Out of Paper; Load Tray 1 (MPT) with [size] [type] | 3-57 |
| Out of Paper; Load Tray [2][3][4][5] with [size][type] | 3-58 |
| Output Tray Is Full, Unload Paper | 3-60 |
| Media Mismatch Errors | 3-61 |
| Wrong Paper Size; Load Tray 1 (MPT) with [size][type] | 3-61 |
| Wrong Paper Size; Load Tray 2 with [size][type] | 3-62 |

| | |
|---|------|
| Wrong Paper Size; Load Tray [3][4][5] with [size][type] | 3-63 |
| Configuration Errors | 3-64 |
| Invalid or Missing Configuration Card | 3-64 |
| Duplicate IP Address Detected | 3-65 |
| Unsupported Configuration | 3-65 |
| Fatal Error Procedures | 3-66 |
| Laser Failure | 3-66 |
| Density Sensor Failure | 3-67 |
| Fuser Failure | 3-68 |
| Fuser Failure | 3-69 |
| Fuser Failure | 3-70 |
| Fuser Fan Failure | 3-71 |
| Rear Fan Failure | 3-72 |
| Fan Failure | 3-73 |
| Fuser Firmware Failure | 3-74 |
| Engine Firmware Failure | 3-75 |
| Engine Firmware Failure | 3-75 |
| Engine NVRAM Error | 3-76 |
| [Y] [M] [C] [K] Toner Cartridge Failure | 3-77 |
| Environmental Sensor Failure | 3-78 |
| Fuser Motor Failure | 3-79 |
| Developer Motor Failure | 3-80 |
| Main Motor Failure | 3-81 |
| Motor Failure | 3-82 |
| Disk Failure | 3-83 |
| Image Density Failure | 3-84 |

4 General Troubleshooting

| | |
|---|------|
| Introduction | 4-2 |
| System Startup | 4-2 |
| Power On Self Test (POST) | 4-3 |
| POST Soft Fault Messages | 4-4 |
| POST Hard Fault Messages | 4-5 |
| Fault Isolation | 4-5 |
| Service Diagnostics | 4-6 |
| Using Service Diagnostics | 4-6 |
| Service Diagnostics Controls | 4-7 |
| Service Diagnostics Utilities | 4-8 |
| Status | 4-9 |
| Test Prints | 4-9 |
| Diagnostic Fault History | 4-9 |
| Control Panel Troubleshooting | 4-11 |
| No Control Panel Display after Power Is Turned On | 4-11 |
| Control Panel LED Is On, Control Panel Display Is Blank | 4-11 |

| | |
|---|------|
| Inoperable Printer Troubleshooting | 4-12 |
| Engine Power-Up Sequence | 4-12 |
| Printer Continually Displays Warming Up... | 4-12 |
| Printer Continually Displays Install or Reseat Imaging Unit | 4-12 |
| Printer Displays Reseat Controller Board | 4-12 |
| Printer Does Not Come to a Ready State | 4-13 |
| Paper Size Switch Assembly | 4-13 |
| Power Supply | 4-13 |
| AC Power Supply Troubleshooting | 4-14 |
| DC Power Supply Troubleshooting | 4-14 |
| RAM Memory Fault Isolation | 4-16 |
| Media Jams and the Paper Path | 4-18 |
| Operating System and Application Problems | 4-20 |
| Macintosh Printing Problems | 4-20 |
| Windows Printing Problems | 4-22 |
| Network Problems | 4-23 |
| Network Diagnostics | 4-23 |
| Network Logging | 4-25 |
| USB Port Testing | 4-26 |

5 Print-Quality Troubleshooting

| | |
|---|------|
| Print-Quality Problems Overview | 5-2 |
| Defects Associated with Specific Printer Components | 5-3 |
| Test Prints | 5-4 |
| Test Print 1: CMYK Sample Page | 5-4 |
| Test Print 2: RGB Test Print | 5-5 |
| Test Print 3: Test Patterns | 5-6 |
| 600 x 600 Test Print | 5-8 |
| Engine Test Print | 5-9 |
| Print-Quality Troubleshooting | 5-10 |
| Light Prints | 5-10 |
| Light Print in Only One Color | 5-12 |
| Blank Prints | 5-14 |
| Black Prints with White Margin Border | 5-16 |
| Solid Dark or Dirty Prints, No Border | 5-17 |
| Horizontal Bands, Voids Or Streaks in Any or All Colors | 5-18 |
| Vertical Bands, Voids or Streaks in Any or All Colors | 5-20 |
| Repeating and/or Random Spots | 5-22 |
| Background Contamination | 5-24 |
| Residual Image, Ghosting or Hot Offset | 5-26 |
| Incomplete Fusing or Cold Offset | 5-28 |
| Mis-Registration, Color Layers Not Correctly Registered | 5-29 |
| Dirty Vertical Streaks on the Edges of the Page | 5-30 |

6 Adjustments and Calibrations

| | |
|---|-----|
| Calibrations | 6-2 |
| Color Calibration | 6-2 |
| Margin Calibration | 6-2 |
| Adjustments | 6-3 |
| Vertical and Horizontal Color Registration | 6-3 |
| Resetting NVRAM | 6-4 |
| Restore Factory Registration Settings | 6-4 |
| Restore Factory Color Settings | 6-4 |
| Restore Previous Color Settings | 6-4 |
| Restore Factory Margins Settings | 6-5 |
| Resetting Connection Setup Defaults | 6-5 |
| Resetting Paper Handling Defaults | 6-5 |
| Resetting PostScript Setup Defaults | 6-6 |
| Resetting PCL Setup Values to Default | 6-6 |
| Resetting Control Panel Setup Values to Default | 6-6 |
| Resetting Printer Controls Values to Default | 6-6 |
| Resetting All Printer Defaults (PostScript NVRAM) | 6-7 |
| Developer Assembly Life Count Resets | 6-7 |
| Maintenance Kit Life Count Resets | 6-7 |
| Service Diagnostics NVRAM Utilities | 6-8 |
| Postscript NVRAM Reset | 6-8 |
| Engine Control Board NVRAM Save/Restore | 6-8 |
| Toner Cartridge Install Date | 6-8 |
| Toner Cartridge CRUM Check | 6-9 |
| CRU Life Reset | 6-9 |
| CRU Life Read | 6-9 |

7 Cleaning and Maintenance

| | |
|---|-----|
| Service Maintenance Procedures | 7-2 |
| Cleaning | 7-2 |
| Cleaning the Imaging Unit | 7-3 |
| Cleaning the Developer Assemblies | 7-3 |
| Cleaning the Laser Windows | 7-4 |
| Maintenance | 7-4 |
| RIP (Repair, Inspect, and Prevent) Procedures | 7-4 |
| Long-Life Maintenance Kit Installation | 7-4 |

8 Service Parts Disassembly

| | |
|---|-----|
| Overview | 8-2 |
| Standard Orientation of the Printer | 8-2 |
| Preparation | 8-3 |
| Notations in the Disassembly Text | 8-3 |
| Fastener Types | 8-4 |

| | |
|--|------|
| Maintenance Items and Consumables | 8-5 |
| Transfer Roller Removal | 8-5 |
| Imaging Unit Removal | 8-5 |
| Fuser Removal | 8-5 |
| Toner Cartridge Removal | 8-6 |
| Print Engine Disassembly | 8-6 |
| Covers | 8-8 |
| Top Main Cover (PL1.1.4) | 8-8 |
| Front Cover (PL1.1.6) | 8-10 |
| Control Panel (PL1.1.5) | 8-11 |
| Right Side Cover (PL1.1.20) | 8-12 |
| Left Side Cover (PL1.1.30) | 8-13 |
| Door C (PL1.1.8) | 8-14 |
| Rear Cover (PL1.1.17) | 8-16 |
| Right Front Cover (PL1.1.22) | 8-17 |
| Left Front Cover (PL1.1.28) | 8-18 |
| Front Feeder Frame Cover (PL3.1.1) | 8-19 |
| Universal Tray | 8-20 |
| Retard Assembly (PL2.1.12) | 8-20 |
| Paper Feeder | 8-21 |
| Feeder Chute (PL3.1.2) | 8-21 |
| Tray Rear Cover (PL3.1.3) | 8-22 |
| Printer Chassis | 8-23 |
| Paper Size Switch Assembly (PL3.2.24) | 8-25 |
| Option Feeder Harness (PL3.2.11) | 8-26 |
| Paper Pick Assembly (PL3.3.1) | 8-27 |
| No Paper Sensor (PL3.3.7) | 8-28 |
| Low Paper Sensor (PL3.3.7) | 8-29 |
| Upper Chute (PL3.3.15) | 8-30 |
| Low Paper Sensor Actuator (PL3.3.14) | 8-31 |
| Feed Roller (PL3.3.18) | 8-32 |
| No Paper Sensor Actuator (PL3.3.20) | 8-33 |
| Retard and Registration | 8-34 |
| Registration Chute (PL4.1.5) | 8-34 |
| Registration Sensor Actuator (PL4.1.1) | 8-35 |
| Registration Sensor (PL4.1.3) | 8-36 |
| Retard Holder Assembly (PL4.1.16) | 8-37 |
| Registration Roller Assembly (PL4.2.1) | 8-38 |
| Tray 1 (MPT) | 8-39 |
| Tray 1 (MPT) (PL1.1.23) | 8-39 |
| Tray 1 (MPT) Cover (PL1.1.27) | 8-40 |
| Tray 1 (MPT) Feed Solenoid (PL5.3.9) | 8-41 |
| Tray 1 (MPT) No Paper Sensor and Actuator (PL5.3.14) | 8-45 |
| Tray 1 (MPT) Feed Roller (PL5.3.20) | 8-49 |

| | |
|---|-------|
| Chute Assemblies | 8-52 |
| Full Stack Sensor (PL5.4.1) | 8-52 |
| Full Stack Actuator (PL5.4.2) | 8-53 |
| Duplex Jam Sensor (PL5.4.1) and Actuator (PL5.4.13) | 8-54 |
| Duplex Motor Assembly (PL5.4.5) | 8-57 |
| Chute Assembly In (PL5.2.1) | 8-58 |
| Chute Assembly Out (PL5.3.1) | 8-61 |
| Xerographics | 8-66 |
| Fuser Fan (PL5.3.31) | 8-66 |
| Fuser (PL5.1.1) | 8-67 |
| Fuser Exit Sensor Actuator (PL5.1.2) | 8-68 |
| Fuser Lock Lever (PL5.2.2) | 8-69 |
| Transfer Roller (PL5.1.4) | 8-70 |
| CTD (ADC) Sensor (PL5.2.19) | 8-71 |
| Toner Full Sensor (PL5.2.20) | 8-72 |
| Laser Unit (PL6.1.2) | 8-76 |
| Housing Assembly Bias (PL6.1.7) | 8-77 |
| Development | 8-78 |
| Developer Frame Assembly (PL7.1.1) | 8-78 |
| CRUM Connector (PL7.1.4) | 8-80 |
| Developer Assembly (PL7.1.17~20) | 8-81 |
| CRUM Reader (PL7.2.12) | 8-83 |
| Toner Cartridge Holder (PL7.2.1~4) | 8-85 |
| No Toner Sensor (Y), (M), and (C) (PL7.2.5) | 8-87 |
| No Toner Sensor (K) (PL7.2.5) | 8-88 |
| Toner CTG-IN Actuator and Switch Bracket (PL7.2.7) | 8-89 |
| Toner Cartridge Holder Assembly | 8-90 |
| Drive | 8-93 |
| Developer Drive Assembly (PL8.1.1) | 8-93 |
| Main Drive Assembly (PL8.1.2) | 8-95 |
| Fuser Drive Assembly (PL5.2.25) | 8-96 |
| Electrical | 8-98 |
| Image Processor Board (PL9.1.3) | 8-98 |
| LVPS (PL9.1.4) | 8-99 |
| Interlock Switch (PL9.1.11) | 8-101 |
| Rear Fan (PL1.1.19) | 8-102 |
| EEPROM Board (PL9.1.12) | 8-103 |
| Engine Control Board (PL9.1.16) | 8-104 |
| Temperature/Humidity Sensor (PL9.1.20) | 8-108 |
| HVPS (PL9.1.21) | 8-109 |
| Optional 1100-Sheet Feeder Disassembly | 8-110 |
| Docking (PL12.1.1) | 8-110 |
| Front Covers (PL12.1.6) | 8-111 |
| Left Cover (PL12.1.2) | 8-112 |
| Right Cover (PL12.1.3) | 8-113 |
| Foot (PL12.1.10) | 8-114 |

| | |
|---------------------------------------|-------|
| Feeder Chute (PL12.2.7) | 8-115 |
| Left Feeder Assemblies (PL12.2.1) | 8-116 |
| Right Feeder Assemblies (PL12.2.4) | 8-117 |
| Paper Size Switch (PL12.2.6) | 8-118 |
| OPTFDR 2 Harness (PL12.3.1) | 8-119 |
| Circuit Board HCF (PL12.3.3) | 8-120 |
| Drive Assembly (PL12.3.9) | 8-121 |
| Paper Pick Assembly HCF T1 (PL12.4.1) | 8-122 |
| Paper Pick Assembly HCF T2 (PL12.5.1) | 8-125 |
| No Paper Sensor (PL12.5.7) | 8-128 |
| Low Paper Sensor (PL12.5.7) | 8-129 |
| Low Paper Sensor Actuator (PL12.5.14) | 8-130 |
| Feed Rollers (PL12.4.19) | 8-131 |
| No Paper Sensor Actuator (PL12.5.20) | 8-132 |
| Retard Roller Assembly (PL12.6.13) | 8-133 |
| Optional 550-Sheet Feeder Disassembly | 8-134 |
| Docking (PL11.1.1) | 8-134 |
| Right Cover (PL11.1.11) | 8-135 |
| Left Cover (PL11.1.7) | 8-136 |
| OPTFDR 1 Harness (PL11.1.6) | 8-137 |
| Circuit Board LTA (PL11.1.10) | 8-138 |
| OPTPLG 2 Harness (PL11.1.13) | 8-139 |
| Paper Size Switch (PL11.2.6) | 8-140 |
| Paper Pick Assembly (PL11.3.1) | 8-141 |
| No Paper Sensor (PL11.3.7) | 8-143 |
| Low Paper Sensor (PL11.3.7) | 8-144 |
| Drive Assembly (PL11.3.15) | 8-146 |
| Low Paper Sensor Actuator (PL11.3.16) | 8-147 |
| Feed Rollers (PL11.3.20) | 8-148 |
| No Paper Sensor Actuator (PL11.3.22) | 8-149 |
| Retard Roller Assembly (PL11.4.12) | 8-151 |

9 Parts List

| | |
|--------------------------------|------|
| Serial Number Format | 9-2 |
| Using the Parts List | 9-3 |
| Print Engine Parts | 9-4 |
| Optional 550-Sheet Feeder | 9-38 |
| Optional 1100-Sheet Feeder | 9-46 |
| Xerox Supplies and Accessories | 9-58 |
| Service Kits | 9-60 |
| Feed Roller Kit | 9-60 |
| Spring Kit | 9-61 |
| Sensor Acuator Kit | 9-62 |
| Long-Life Maintenance Kit | 9-62 |
| Hardware Kit | 9-63 |
| Harness Kit | 9-64 |

10 Wiring Diagrams

| | |
|--|-------|
| Plug/Jack Locator Diagrams | 10-2 |
| Print Engine Plug/Jack Designators | 10-2 |
| Print Engine Plug/Jack Locators | 10-5 |
| 1100-Sheet Feeder Plug/Jack Designators. | 10-9 |
| 1100-Sheet Feeder Plug/Jack Locator | 10-10 |
| 550-Sheet Feeder Plug/Jack Designators. | 10-11 |
| 550-Sheet Feeder Plug/Jack Locator | 10-12 |
| Wiring Diagrams | 10-13 |
| Notations Used in Wiring Diagrams | 10-13 |
| Print Engine Wiring Diagrams | 10-15 |
| Print Engine General Wiring (1/2) | 10-15 |
| Print Engine General Wiring (2/2) | 10-16 |
| Power | 10-17 |
| Tray 2. | 10-18 |
| Drive Section | 10-19 |
| Developer (1/2) | 10-20 |
| Developer (2/2) | 10-21 |
| Fuser | 10-22 |
| Laser Unit | 10-23 |
| Xerographics (1/2). | 10-24 |
| Xerographics (2/2). | 10-25 |
| Paper Feed | 10-26 |
| Image Processor Board | 10-27 |
| Control Panel | 10-28 |
| 1100-Sheet Feeder Wiring Diagrams. | 10-29 |
| 1100-Sheet Feeder General Wiring | 10-29 |
| Drive | 10-30 |
| Upper Tray. | 10-31 |
| Lower Tray. | 10-32 |
| 550-Sheet Feeder Wiring Diagrams. | 10-33 |
| 550-Sheet Feeder General Wiring | 10-33 |
| Drive | 10-34 |
| Tray | 10-35 |

Reference

| | |
|--|------|
| Phaser 6300/6350 Menu Map | A-2 |
| Printer Status Codes | A-4 |
| Service Diagnostics Menu Map | A-10 |
| Service Diagnostics Tests | A-11 |
| Mode Select Port. | A-18 |
| Obtaining Serial Back Channel Traces | A-19 |
| Preparing the Printer for Shipment | A-20 |

Index

General Information

In this chapter...

- Printer Introduction and Overview
- Printer Configurations
- Parts of the Printer
- Printer Options
- Specifications

Section

1

Printer Introduction and Overview

The Xerox Phaser 6300/6350 Color Laser Printer combines a single-pass, tandem color laser design, with an image processor supporting PostScript 3 and PCL5c page description languages. The printer is a high performance, Letter or A4, 25 (Phaser 6300) or 36 (Phaser 6350) page per minute (ppm), desktop color laser printer supporting resolutions up to 2400 x 600 dots-per-inch (dpi). The printer features USB and 10/100baseT Ethernet ports. The Phaser 6300/6350 printer provides a 150-sheet Tray 1 (MPT) from which specialty media, card stock, and envelopes are fed. Tray 1 (MPT) also supports manual feeding. An additional tray, Tray 2 provides 550 sheets of capacity. The Output Tray holds 250 sheets facedown.

Phaser 6300/6350 printer options add memory, paper capacity and functionality. For configurations not originally equipped, an internal Hard Drive is available for font storage, storing print files, job collation, proof, personal, and secure print support. A selection of RAM memory upgrades are available to raise the installed quantity to the 1 GB maximum. A 1100-Sheet Feeder is available with two, 550-sheet universal trays. A 550-Sheet Feeder (Tray 3) is also available. A Configuration Card enables Auto-duplexing (2-sided) printing.

Phaser 6350 Printer with Optional 550- and 1100-Sheet Feeders

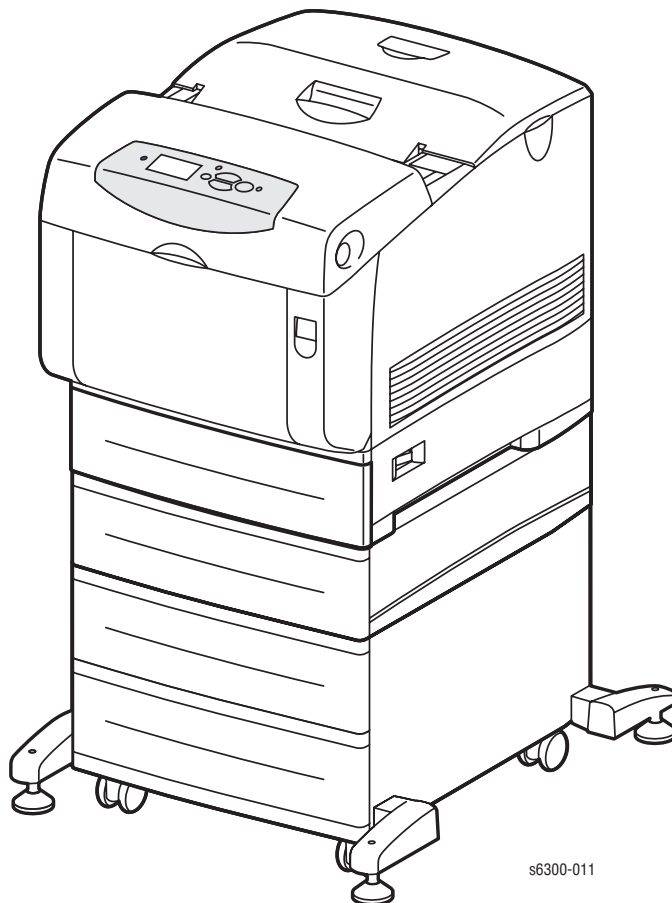

Printer Configurations

The Phaser 6300/6350 printer is available in five configurations. The main differences are standard memory, optional high-capacity feeders, duplexing (2-sided printing) capabilities, and optional internal hard drive. The following table lists the available configurations.

| Features | Printer Configuration | | | | |
|--|-----------------------|-----------|-----------|-----------|-----------|
| | 6300N | 6300DN | 6350DP | 6350DT | 6350DX |
| Max Print Speed (ppm) color/monochrome | 26/36 | 26/36 | 36/36 | 36/36 | 36/36 |
| Hard Drive for Secure, Proof, Personal, and Saved Print Jobs | Optional | Optional | Optional | Optional | Yes |
| Standard Memory* | 256 MB | 256 MB | 256 MB | 512 MB | 512 MB |
| USB Port | Yes | Yes | Yes | Yes | Yes |
| 10/100 Ethernet Port | Yes | Yes | Yes | Yes | Yes |
| RAM Collation | Yes | Yes | Yes | Yes | Yes |
| Duplex Unit | No | Yes | Yes | Yes | Yes |
| PostScript and PCL Fonts | Yes | Yes | Yes | Yes | Yes |
| Banner Sizes | Yes | Yes | Yes | Yes | Yes |
| Photo Modes | Yes | Yes | Yes | Yes | Yes |
| Resolutions (dpi): | | | | | |
| Standard | 1200x600 | 1200x600 | 1200x600 | 1200x600 | 1200x600 |
| Enhanced | 2400x600 | 2400x600 | 2400x600 | 2400x600 | 2400x600 |
| Photo | 1200x1200 | 1200x1200 | 1200x1200 | 1200x1200 | 1200x1200 |
| Tray 1 (MPT)** | Yes | Yes | Yes | Yes | Yes |
| Tray 2 ** | Yes | Yes | Yes | Yes | Yes |
| 550-Sheet Feeder** | Optional | Optional | Optional | Yes | Optional |
| 1100-Sheet Feeder** | Optional | Optional | Optional | Optional | Yes |

* All configurations have two memory slots supporting 256 MB and 512 MB cards, to a maximum of 1 GB.

** Trays 1 and 2 are standard on all configurations. All configurations support additional paper trays in the following combinations:

One 550-sheet feeder (Tray 3)

One 1100-sheet high-capacity feeder (Trays 3 and 4 or 4 and 5)

One 550-sheet feeder (Tray 3) and one 1100-sheet high-capacity feeder (Trays 4 and 5)

Metered Printing

Metered printing (PagePack), involves the combination of control software and specialized Toner Cartridges to meter printer activity for billing purposes. The Configuration page lists Metered Toner as Enabled when metering is enabled.

Metered Operation

When a metered printer is initialized at first power-up, the customer sets the printer to Metered operation using a unique, factory-supplied, 4-digit PIN. Once set to Metered operation, the control software performs the following:

1. The Mode and PIN-entered values in Engine Control Board NVRAM are set.
2. The Control Panel momentarily displays “Metered Toner is now enabled”, then returns to “Ready” (if no other errors).
3. The First Time Tips pages and the Configuration page are printed.

If an incorrect PIN is entered, “Incorrect numeric password” displays with a prompt “Retry” or “Do not retry.” Retry returns to the enter prompt, “Do not retry” returns to the Replace [C][M][Y][K] Toner Cartridge error message. The error persists until the correct PIN is entered.

Note

The Hidden Service menu provides an Enable Metered Toner option to restore the Metered mode parameters to NVRAM should they become lost or corrupt.

Metered Toner Cartridges

To support metered printing, metered Toner Cartridges are available in all four colors. When a metered Toner Cartridge is installed in a printer not set to Metered operation, the printer displays the “Replace [C][M][Y][K] Toner Cartridge” error. If a metered Toner Cartridge is placed into a printer manufactured before metering was available, the printer displays “Replace Incorrect Toner Cartridge.” All other combinations of normal or metered printer and cartridges are accepted without warning or error.

Diagnostics Mode

Service Diagnostics does not provide the utilities to set or clear Metered NVRAM values. Service Diagnostics does not check these values and does not display the current status of these values. However, the Configuration page does identify the printer setting as mentioned above.

Note

When replacing the Engine Control Board from a metered printer, exchange NVRAM devices or use the Save/Restore utilities in Service Diagnostics to preserve the NVRAM settings. The Mode and PIN-entered values are not affected by NVRAM reset utilities.

Parts of the Printer

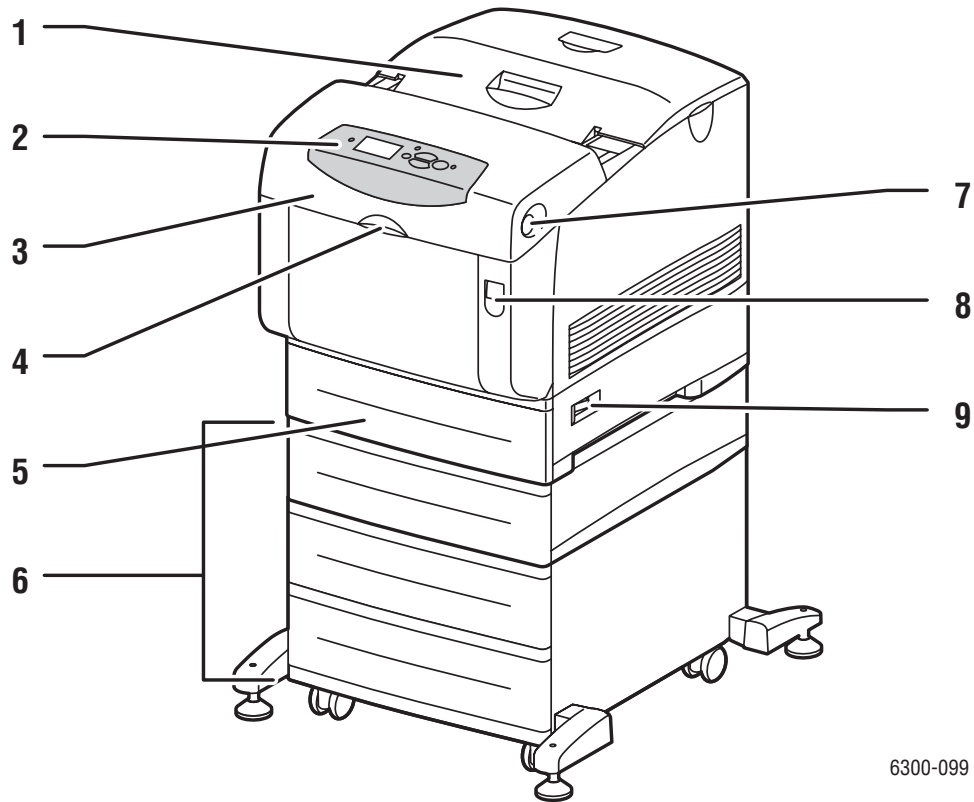

6300-099

- | | |
|----------------------------------|---|
| 1. Top Cover (Output Tray) | 6. Optional Feeders (Tray 3 / Tray 4 and 5) |
| 2. Control Panel | 7. Door B Latch |
| 3. Front Cover | 8. Door A Latch |
| 4. Tray 1 (MPT) Latch | 9. Power Switch |
| 5. Tray 2 (Universal Paper Tray) | |

Control Panel

The Control Panel contains one tricolor LED, a display window, and six function buttons. These buttons navigate the menu system shown in the display window, perform various functions, and select modes of operation for the printer.

LED Indicators:

| LED State | Printer State |
|-----------------|--|
| Green | Ready to Print |
| Flashing Yellow | Warning (but can still print) |
| Flashing Green | In Power Saver mode or busy (receiving or processing data) |
| Flashing Red | Error; cannot print |

Control Panel Button Descriptions

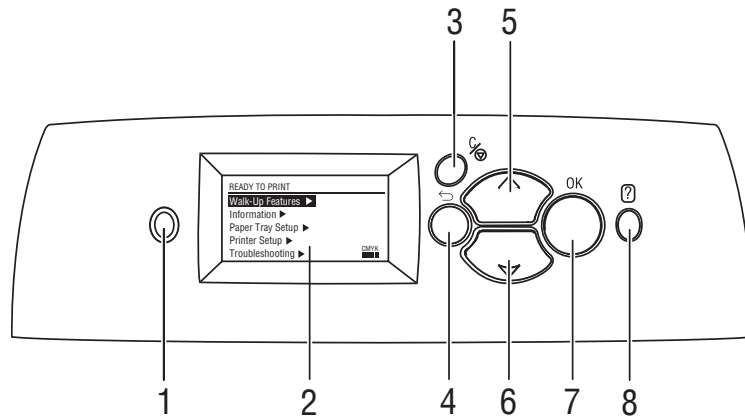

s6300-013

- | | |
|--------------------------------|---|
| 1 LED (Power/Status) | 5 Up Arrow Button - scrolls up the menu |
| 2 Control Panel Display | 6 Down Arrow Button - scrolls down the menu |
| 3 Cancel Button | 7 OK (select) Button |
| 4 Back Button | 8 Help (?) Button - for explanation or help |

Control Panel Shortcuts

| Action | Press this at Power On |
|------------------------------------|------------------------------|
| Skip Execution of POST Diagnostics | OK |
| Print Service Diagnostics Menu Map | Help (?) |
| Reset PostScript NVRAM | Back + OK |
| Password Bypass | Up Arrow + Down Arrow |
| Enter Service Diagnostics | Back + Help (?) |

Rear Panel

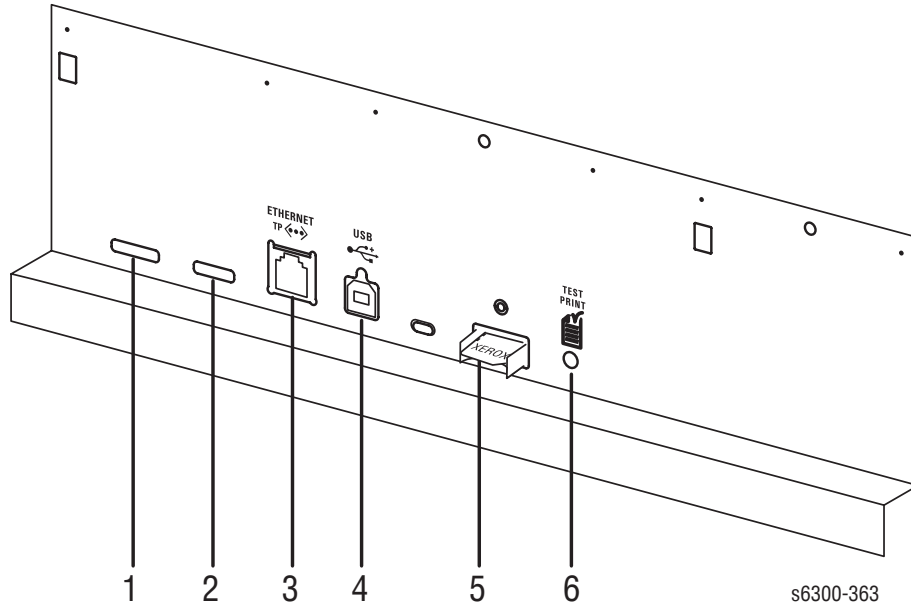

- 1. Mode Select Port
- 2. Serial Debug Port
- 3. Ethernet Port
- 4. USB Port
- 5. Configuration Card Port
- 6. Test Print Button

Image Processor Board

Transfer the following components, if installed, to the new board when replacing the Image Processor Board.

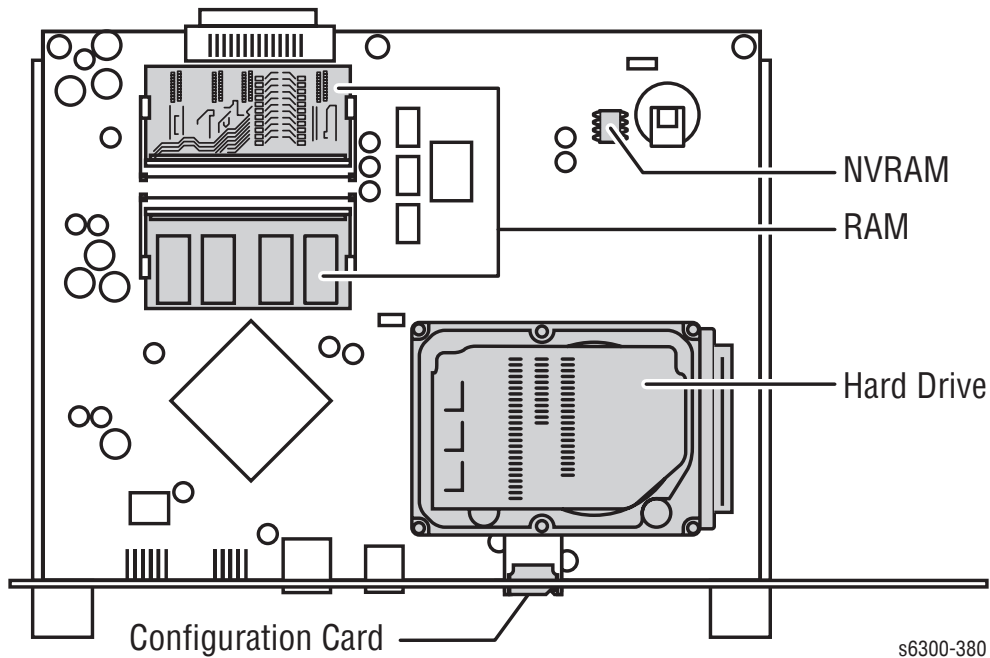

Printer Options

Phaser 6300/6350 printer options include:

- 20 GB Hard Drive
- Additional Memory
- Configuration Card
- 1100-Sheet Feeder
- 550-Sheet Feeder

Hard Drive

A 20 GB Hard Drive is available to enable the Job Collation, Saved Jobs, Proof, Personal, and Secure Print options. The Hard Drive installs on the Image Processor Board with stand-offs and connects to the board with a single data/power connector. Hard Drive utilization appears on the Configuration page.

Additional Memory

The printer features two slots that accept 256 or 512 MB of high-speed DDR RAM. All combinations are allowed for 256, 512, 768 MB and 1 GB. Memory modules must have the following characteristics:

- DDR PC2700 Memory Standard
- 200-Pin SODIMM
- Unbuffered, Non-parity
- Serial Presence Detect
- 2.5 Volt
- CL 2.5

The Startup page and the Configuration page list the amount of RAM installed in the printer. Installed memory not meeting the above specifications, is ignored by the printer.

Configuration Card

A Configuration Card identifies the printer configuration, stores shadowed non-CRUM consumable data, consumable life counts, and network configuration parameters.

550-Sheet Feeder

The 550-Sheet Feeder (Tray 3) increases the input capacity of the printer. The feeder attaches below Tray 2 with four screws. When used in combination with the 1100-Sheet Feeder, the 550-Sheet Feeder is installed between the printer and 1100-Sheet Feeder. Only one 550-Sheet Feeder per printer is allowed. Electrical connection to the printer is made by a single interface connector.

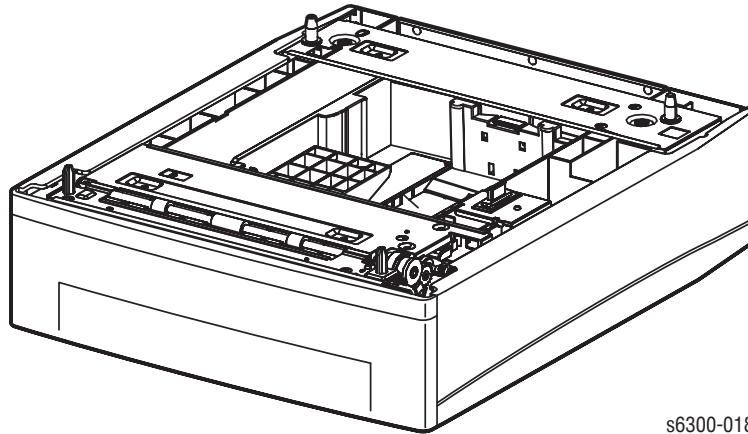

s6300-018

1100-Sheet Feeder

The 1100-Sheet Feeder adds two, 550-sheet trays. Control signals reach the sheet feeder by a single connection. The sheet feeder is secured to the print engine or 550-Sheet Feeder with four screws located under the front and rear edges of the tray.

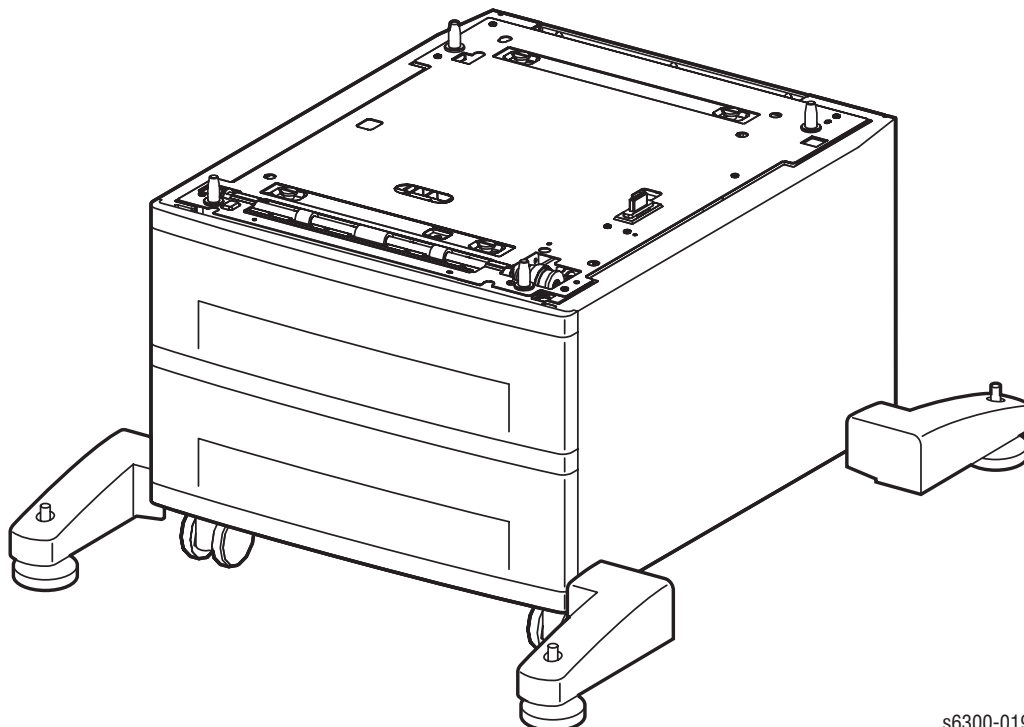

s6300-019

Maintenance Items

A maintenance item is a printer part or assembly that has a limited life, and requires periodic replacement.

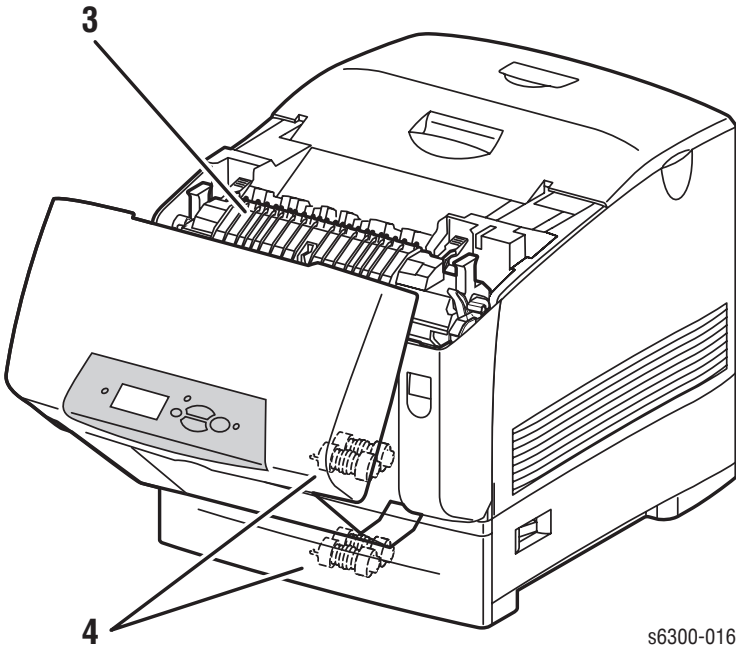
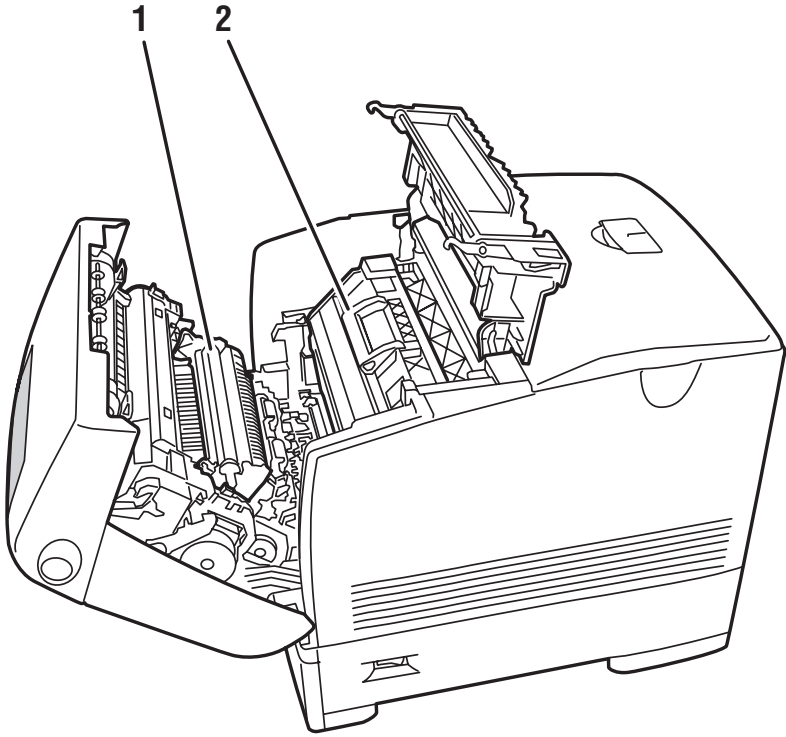

s6300-016

1. Transfer Roller

2. Imaging Unit

3. Fuser

4. Feed Rollers

Consumables

Consumables consist of the four toner cartridges used in the printer.

Note

Toner Cartridges installed at the time of manufacture contain sufficient additional toner to prime the Auger Tubes without reducing the 4K life expectancy. These specialty cartridges are not available as replacement parts.

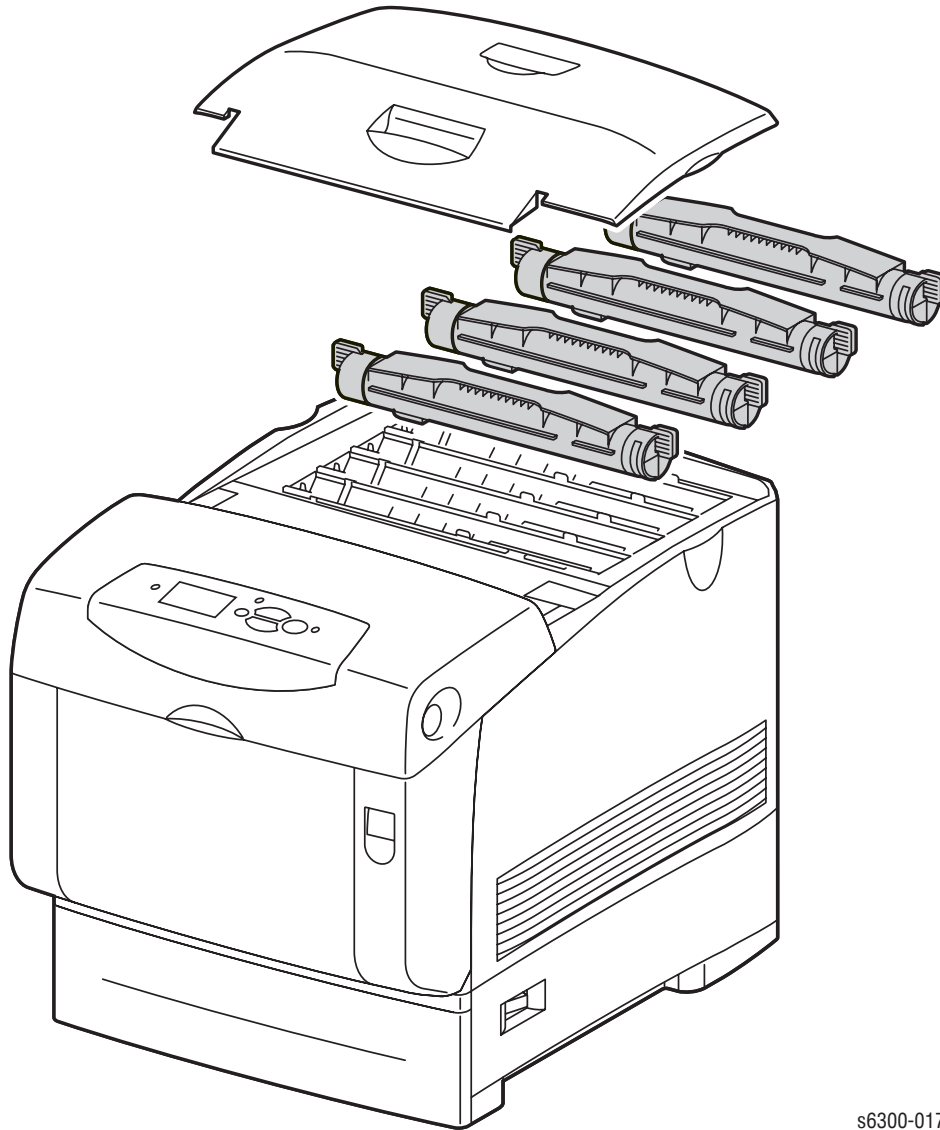

s6300-017

Consumable Life Counter Behavior

Internal counters track Consumables and Maintenance Items life usage. The Image Processor Board monitors these counters in order to display the near end-of-life and end-of-use messages.

Life ratings are based on A-size sheets at 5% coverage. Imaging Unit life ratings are based on average 4 page job length.

| Toner Cartridges | Print Life |
|--|--------------------------------------|
| Black-Capacity | 4000, 7000 or (10,000 for 6350-only) |
| Color Capacity | 4000, 7000 or (10,000 for 6350-only) |
| Metered (PagePack) Capacity (all colors) | 10,000 (6300 or 6350) |
| Maintenance Items | |
| Imaging Unit | 35,000 |
| Fuser | 100,000 |
| Transfer Roller and Waste Box | 35,000 |
| Feed Roller Kit | up to 100,000 |
| Long-Life Maintenance Kit | up to 300,000 |

Specifications

Memory Specifications

| Characteristic | Specification |
|-----------------------|--|
| Minimum RAM | 256 MB |
| Maximum RAM | 1 GB |
| Supported RAM | SODIMM 200-pin module of 256 or 512 MB. All combinations are allowed for configurations of 256, 512, 768 MB, and 1 GB. |
| NVRAM | Single chip of either PPRAM or StrataFlash 16 MB |

Electrical Specifications

| Characteristic | Specification | | | |
|--|--|---|--|--------------------|
| Primary line voltages | 110-127 V Printer - (90 - 135 V) 13 amp circuit 220-240 V Printer - (198 - 254 V) 7-8 amp circuit | | | |
| Primary line voltage frequency range | 100-120 V Printer - 50/60 Hz \pm 3 Hz | 220-240 V Printer - 50/60 Hz \pm 3 Hz | NOTE: Power the printer directly from the wall outlet. Do not use "Power Strips" as they may limit available current. | |
| In-rush Current | 100A, and 10m sec (half cycle) or less. at rated voltage: \pm 10% | | | |
| Power consumption at rated voltage input | Mode | Condition | 100/120 VAC | 220/240 VAC |
| | Print Mode | Maximum | 1300 W or less | 1300 W or less |
| | Ready Mode | Fuser On | 180 W or less | 180 W or less |
| | Sleep Mode | Fuser Off | 45 W or less | 45 W or less |

Physical Dimensions and Clearances

| Print Engine | Value |
|--------------------------|---|
| Height: | 457 mm (18.00 in.) |
| Width: | 429 mm (16.88 in.) |
| Depth: | 580 mm (22.83 in.) |
| Weight: | Approximately 34.6 kg (76.1 lb.) Print engine Approximately 56.5 kg (124.5 lb.) with Paper Tray(s) installed |
| 1100-Sheet Feeder | Value |
| Height: | 341 mm (13.42 in.) Optional Paper Tray Assembly |
| Width: | 429 mm (16.88 in.) |
| Depth: | 509 mm (20.04 in.) |
| Weight: | Approximately 17.6 kg (38.72 lb.) |
| 550-Sheet Feeder | Value |
| Height: | 130 mm (5.12 in.) Optional Paper Tray Assembly |
| Width: | 429 mm (16.88 in.) |
| Depth: | 509 mm (20.04 in.) |
| Weight: | 6.3 kg (13.9 lb.) |
| Surface | Value |
| Tilt tolerance: | Within 10 mm front to back or 5 mm side to side. |

Minimum Clearances

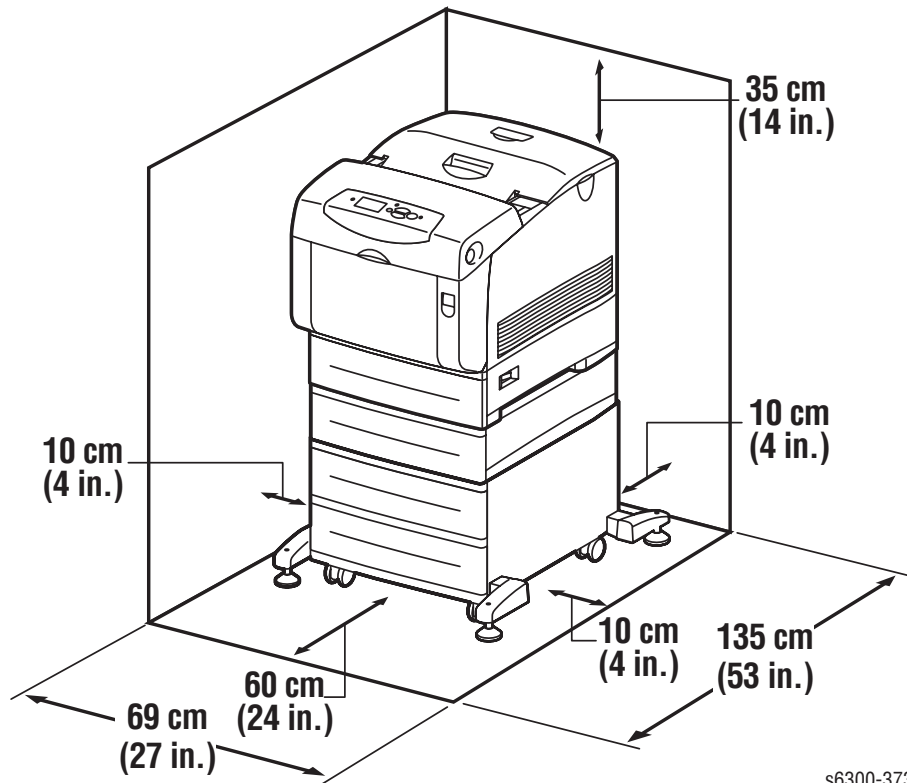

s6300-373

Functional Specifications

Functional Specifications

| Characteristic | Specification |
|---|---|
| Printing Process | Imaging System: - 4-tandem drums, electro-photographic system using intermediate drum transfer rolls (IDTs). Exposure System: - Semiconductor laser, simultaneous scan by 4 beams. Development System: - Dry type 2-component developer. Fusing System: - Heat fusing, free nip-belt system. |
| Color Medium | Yellow, Magenta, Cyan, and Black Toner Cartridges |
| Resolution / Addressability | Standard 1200 x 600 dpi (default) Enhanced 2400 x 600 dpi Photo 1200 x 1200 dpi |
| Operating Modes | Print Mode: Print Engine capable of making prints immediately. Ready Mode: 20 seconds from completion of a print. Sleep/ Low Power/ Power Saver Mode: Entered after a specified period of Print Engine inactivity since completion of the last print. |
| Maximum Color Coverage | 6300N and DN configurations is 240% at 26 ppm 6350DP, DT, and DX configurations is 200% at 36 ppm |
| Print Speed Phaser 6350DP, 6350DT, and 6350DX Configurations | |
| Resolution | Letter/A4 Letter/A4 Duplex (ipm) Legal Legal Duplex (ipm) |
| Standard: | 36/35 21/20 29 20 |
| Enhanced: | 26/24 15/15 20 13 |
| Photo: | 18/18 11/11 12 8 |
| Transparencies | 12 N/A N/A N/A |
| 100-163 g/m ² | 18/18 11/11 12 8 |
| 163-216 g/m ² | 12 N/A 8 N/A |
| Print Speed Phaser 6300N and 6300DN Configurations | |
| Resolution | Letter/A4 Letter/A4 Duplex (ipm) Legal Legal Duplex (ipm) |
| Standard: | 26/24 15/15 20 13 |
| Enhanced: | 26/24 15/15 20 13 |
| Photo: | 18/18 11/11 12 8 |
| Transparencies | 12 N/A N/A N/A |
| 100-163 g/m ² | 18/18 11/11 12 8 |
| 163-216 g/m ² | 12 N/A 8 N/A |
| Warm-up Time | 45 seconds from cold start (power off condition) 30 seconds from (standby) |

Image Specifications

| Characteristic | Specification |
|------------------------------------|--|
| Maximum Print Area ^a | 210.9 mm (8.3 inches) x 890 mm (35 inches) |
| Guaranteed Print Area ^b | 207.9 mm (8.2 inches) x 347.6 mm (13.7 inches) |
| Skew | ± 1.2 mm across 190 mm image |
| Registration | |
| Leading Edge | ± 2.0 mm |
| Side Edge | ± 2.5 mm |
| Duplex (front to back) | ± 4.0 mm |
| Parallelism | ± 1.2 mm across 234 mm image |
| Linearity | |
| Vertical | ± 0.5 mm across 234 mm image |
| Horizontal | ± 0.5 mm across 190 mm image |
| Slant | ± 1.2 mm across 269 mm image |

- Set margin area within 2.5 mm from each of side edge and 2.0 mm from each of top/bottom edge.
- The printer prints images meeting the Print Quality Specification except the margin area, which is 4.0 mm inside each edge of the paper.

Imaging Unit Cleaning Cycle Intervals

Cleaning cycle intervals decrease as the Imaging Unit print volume (life count) increases. Other factors, such as print mode and area of coverage per print can also increase the frequency of cleaning cycles irrespective of the Imaging Unit life count.

| Imaging Unit Print Volume | Cleaning Cycle Interval | | | | | | | |
|---------------------------|-------------------------|--------|--------|--------|-------------|--------|--------|--|
| | B/W Speed | | | | Color Speed | | | |
| | 36 ppm | 18 ppm | 12 ppm | 36 ppm | 26 ppm | 18 ppm | 12 ppm | |
| 0 - 5120 | 108 | 54 | 39 | 72 | 52 | 36 | 26 | |
| 5121 - 10240 | 72 | 36 | 26 | 48 | 35 | 34 | 17 | |
| 10241 - 15360 | 72 | 36 | 26 | 48 | 35 | 34 | 17 | |
| 15361 - 20480 | 72 | 36 | 26 | 48 | 35 | 34 | 17 | |
| 20481 - 25600 | 54 | 27 | 20 | 36 | 26 | 18 | 13 | |
| 25601 - 30720 | 54 | 27 | 20 | 36 | 26 | 18 | 13 | |
| above 30721 | 54 | 27 | 20 | 36 | 26 | 18 | 13 | |

- 36 ppm (6350 standard mode)
- 26 ppm (6300 standard & Enhanced mode)
- 18 ppm (Most specialty medias and Photo mode)
- 12 ppm (Thick Card & envelopes)

Environmental Specifications

| Characteristic | Specification | |
|-----------------------------|---|-----------------------------|
| Temperature: | | |
| Operating | 5° C to 32° C (41° F to 90° F) | |
| Optimal Print Quality Range | 15° -28°C (60° to 82° F) | |
| Storage | | |
| 12 month maximum | Normal: 0° C to 35° C (32° F to 95° F), at 15% - 85% RH | |
| 48 hours maximum | Severe: -20° C to 40° C (-4° F to 104° F) at 5% - 95% RH | |
| Humidity (RH) | | |
| Operating | 15% - 85% RH | |
| Optimal Print Quality Range | 20% to 70% RH | |
| Altitude | | |
| Operating | 0 - 3,100 meters (10,170 ft.) | |
| Transportation | 0 - 15,000 meters (30,000 ft.) in pressurized containers. | |
| Acoustic Noise (Lwa) | Printer Only | With Feeder Option |
| Idle | 5.0 B or less | 5.0 B or less |
| Printing | 6.65 B or less (Full Speed) | 7.35 B or less (Full Speed) |
| | 6.65 B or less (Half Speed) | 7.30 B or less (Half Speed) |

First Print Output Time

First Print Output Time (FPOT) is defined as a time from receipt of the print command in Ready mode until the first page sourced from either Tray 1 or Tray 2 is delivered to the Output Tray. Sourcing media from the optional trays increases FPOT.

Note

This does not include the execution times for the Boot Loader or POST which vary depending on printer configuration.

| Process Speed | First Print Out Time (seconds) | | | |
|---------------|--------------------------------|------------------|-------------------|------------------|
| | Simplex | | Duplex | |
| | Laser Unit Ready* | Laser Unit Off** | Laser Unit Ready* | Laser Unit Off** |
| Full | 6.0 | 10.5 | 10.0 | 14.5 |
| High | 8.0 | 12.5 | 13.5 | 18.0 |
| Mid | 10.5 | 15.0 | 17.5 | 22.0 |
| Low | 15.0 | 19.5 | 25.5 | 30.0 |

These conditions apply to the values in the table above:

* At Fuser ready and Laser Unit Motor is rotating normally.

** At Fuser stand-by and Laser Unit Motor Off.

A4 SEF paper

Plain paper mode

Media and Tray Specifications

Print the Paper Tips page for a complete listing of supported media types and sizes.

Media and Tray Specifications

| | Specification | | Trays |
|---|--|--|-------------|
| Supported Media Sizes | Paper Type | Size | |
| | Letter | 8.5 x 11 in. | All Trays |
| | Legal | 8.5 x 14 in. | All Trays |
| | Executive | 7.25 x 10.5 in. | All Trays |
| | Statement | 5.5 x 8.5 in. | All trays |
| | US Folio | 8.5 x 13 in. | All Trays |
| | A4 | 210 x 297 mm | All Trays |
| | A5 | 148 x 210 mm | All Trays |
| | A6 | 105 x 148 mm | Tray 1 Only |
| | B5 JIS | 182 x 257 mm | All Trays |
| | ISO B5 | 176 x 250 mm | Tray 1 Only |
| Custom Size & Banner | 8.5 x 35.4 in. | Tray 1 Only | |
| Supported Media Types and Weights | Type | Weight | |
| | Plain Paper | 65 - 90 g/m ² (17 - 24 lb. Bond) | All Trays |
| | Heavy Plain Paper | 85 - 120 g/m ² (22 - 32 lb. Bond) | All Trays |
| | Phaser 25-Ser. Premium Transparency Film (Only) | | All Trays |
| | Thin Card Stock | 100 - 163 g/m ² (36 - 60 lb. Cover) | All trays |
| | Thick Card Stock | 160 - 216 g/m ² (59 - 80 lb. Cover) | Tray 1 Only |
| | Labels | N/A | All Trays |
| | Letterhead | 85 - 120 g/m ² (22 - 32 lb. Bond) | All Trays |
| | Glossy Coated Paper | 100 - 163 g/m ² (81 - 110 lb. Text) | All Trays |
| | Digital Photo Paper | 163 g/m ² (60 lb. Cover) | Tray 1 Only |
| | Phaser Premium Post-cards | 176 g/m ² (65 lb. Cover) | Tray 1 Only |
| | Pre-printed | 65 - 90 g/m ² (17 - 24 lb. Bond) | All trays |
| | Pre-punched | 65 - 90 g/m ² (17 - 24 lb. Bond) | All trays |
| | Special | 100 - 163 g/m ² (30 - 60 lb. Cover) | All trays |
| Supported Envelopes* | Envelopes Weight | 20 - 24 lb. Bond | Tray 1 Only |
| | Commercial #10 | 4.12 x 9.5 in. | |
| | Monarch Envelope | 3.87 x 7.5 in. | |
| | A7 Envelope Custom | 5.25 x 7.25 in. | |
| | DL Envelope | 110 x 220 mm | |
| | C5 Envelope | 162 x 229 mm | |
| | C6 Envelope | 114 x 162 mm | |
| B5 Envelope | 175 x 250 mm | | |
| NOTE: Do not use envelopes with hot melt glue, windows, or metal clasps. | | | |

Media and Tray Specifications (Continued)

| Specification | | Trays | |
|-----------------|--|---------------------------------|---------------------|
| Special Media | Phaser 25-Series Premium | | |
| | Transparencies | | |
| | Letter | 216 x 279 mm (8.5 x 11 in.) | All trays |
| | A4 | 210 x 297 mm (8.27 x 11.69 in.) | |
| | (Other sizes through Tray 1 using custom size option.) | | |
| | Phaser Premium Postcards | | |
| | Letter | 216 x 279 mm (8.5 x 11 in.) | Tray 1 Only |
| | A4 | 210 x 297 mm (8.27 x 11.69 in.) | Tray 1 Only |
| Tray Capacity** | Standard Paper | Universal Tray | Tray 1 (MPT) |
| | Transparency | 550 Sheets | 100 Sheets |
| | Envelopes | 100 Sheets | 50 Sheets |
| | | N/A | 10 each |

* Some wrinkling and embossing may occur when printing envelopes.

** To avoid Jams be sure to follow the paper weight guidelines for the Universal Tray capacity: Up to 90 g/m² paper - load the tray to the top fill line. Between 90 ~ 163 g/m² - load the tray to the lower fill line only.

Note

For duplex configured printers, auto-duplex operation is available through all trays. Refer to the Paper Tips page for information on which paper types can be used for 2-sided printing.

Theory of Operation

In this chapter...

- Overview
- Printer Controls
- Paper Path of the Printer
- Major Assemblies and Functions

Section 2

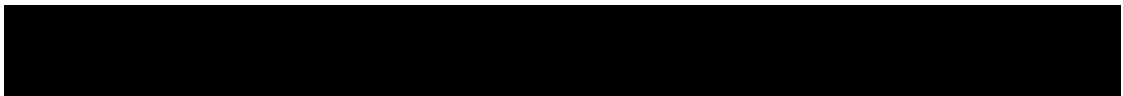

Phaser 6300/6350 Operational Overview

The Phaser 6300/6350 Color Laser Printer is a full-color laser printer that utilizes electrophotographic recording principals to place a full color image onto the print media. The system, as it appears in the following illustration, contains a drum and developing unit for each color [yellow, magenta, cyan and black (YMCK)], and places the toner image of each color onto print media producing full-color prints through three transfer units (primary transfer units [IDT1 (2 ea)] and secondary transfer unit IDT2 (1 ea)].

Print Process Block Diagram

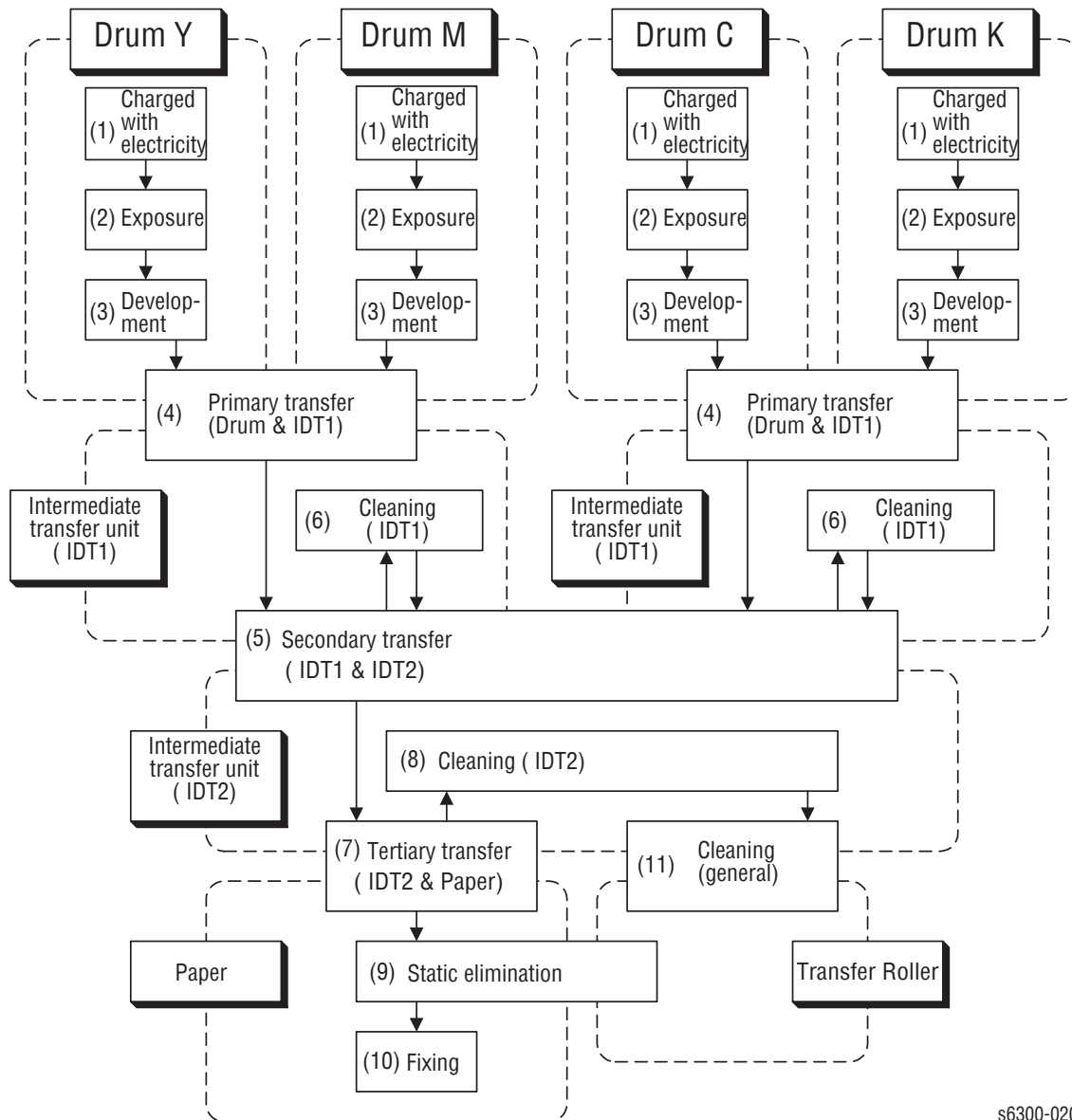

s6300-020

Summary of the Printing Process

The printing process is summarized in the following steps. While reading the summary, refer to the figures on pages 2-2, 2-5, and 2-6. These diagrams show process flow and indicate the relative position of the components involved. The diagrams also include reference numbers that correspond to each numbered step.

- 1. Charging:** The charge roller (RTC) is negatively charged by the High Voltage Power Supply (HVPS) and is kept in contact with the drum surface to provide a uniform negative charge on the drum as it rotates at a constant speed. This occurs simultaneously for YMCK. The refresher is a conductive brush that is also negatively charged by the HVPS to pick off any toner particles left on the drum after image transfer to the IDT.
- 2. Exposure:** The Laser Unit uses a system of mirrors and lenses to scan the drum surface in response to image data from the Image Processor. Where the laser exposes (writes) the drum surface it reduces the negative charge to form an invisible latent image. This process is preformed simultaneously for YMCK.
- 3. Development:** Toner is electrostatically attached to the invisible latent image on the drum surface to form the visible image on the drum. Toner is fed into the developer using the agitator in the Toner Cartridge and auger system in the TCRU. The toner and the carrier in the developer form a homogeneous layer on the magnet roller in the Developer Assembly. The magnet roller turns against the surface of the drum and is kept at a constant negative potential. At areas on the drum surface where the negative charge has not been reduced by the impact of laser light, potential between the drum and the toner particles is lower than that between the magnet roller and the toner particles. At areas where the drum charge has been reduced, the potential between the particles and drum is higher than between the magnet roller and toner particles are attracted to the drum. A thin semiconducting sleeve on the magnet roller is vibrated by an AC voltage to encourage migration of the toner particles to the drum. When the toner particles attach to the drum, the negative charge of the particles reduces drum potential at that point, thus reducing the attraction of additional toner particles. This process occurs simultaneously for YMCK.
- 4. Primary Transfer (drum --> IDT1):** The toner image formed on the individual drum surface is transferred onto the surface of the IDT1 (Intermediate Drum Transfer 1: intermediate transfer roller 1). There are two IDT1's: one for yellow and magenta and one for cyan and black. IDT1 is conductive and receives a high positive charge from the HVPS. The negatively charged toner image on the drum surface is attracted by the high positive potential and transfers to IDT1. During this transfer, the remaining negative charge on the drum is neutralized by the high positive charge on IDT1.
- 5. Secondary Transfer (IDT1 --> IDT2):** The toner images formed on both IDT1 surfaces are then transferred onto the surface of IDT 2 to create a complete, 4-color toner image. IDT2 is biased at a higher positive potential than IDT1 thus attracting the toner image and transferring it from IDT1 to IDT2.
- 6. Cleaning:** The IDT1 cleaner consists of a conductive roller brush rotating in contact with IDT1 after the point where the toner is transferred to IDT2. The cleaner receives a high positive voltage from the HVPS allowing it to electrically attract any toner particles remaining on IDT1. Toner remaining on both IDT1's after the image transfer to IDT2 is temporarily stored in the IDT1 cleaners.

- 7. Tertiary Transfer:** The finished toner image on IDT2 is transferred onto the print media using the biasing charges supplied by the Transfer Roller. The conductive Transfer Roller receives a high positive voltage from the HVPS that puts it at a higher potential than IDT2. Since the Transfer Roller is located behind the print media, the 4-color toner image is attracted to the high potential and transfers to the surface of the print media.
- 8. Cleaning:** The IDT2 cleaner consists of a conductive roller brush rotating in contact with IDT2 after the point where the toner is transferred to the print media. The cleaner receives a high positive voltage from the HVPS allowing it to electrically attract any toner particles remaining on IDT2. Toner remaining on IDT 2 after the image transfer to the print media is temporarily stored in the IDT2 cleaner.
- 9. Static Elimination:** The positive charge on the print media can cause image quality problems by scattering toner. To prevent this, negative DC voltage from the HVPS is applied to the back side of the print media by the Detack Saw, located on the Transfer Roller. This negative charge neutralizes and eliminates the static charge on the print media resulting from the tertiary transfer.
- 10. Fixing:** The initial image is unstable and easily smeared. To fix the image, the print media goes through the Fuser where it passes between a pressure belt and the heat roller. The toner is fused onto the print media by the combination of heat and pressure.
- 11. Cleaning:** During the general cleaning process, the voltage applied to the IDT rollers and drums go through a cycle of changes to move the negative and positive charged toner particles from the cleaners and IDTs and then the Transfer Roller. The toner stored in the IDT1 cleaner, the IDT 2 cleaner is removed and deposited into the Imaging Unit waste toner reservoir. Toner from the Transfer Roller, charge roller and refresher is also removed and deposited into the Transfer Roller waste toner reservoir. In each case the voltage at the point of attraction is set high and the voltage at the point of disposal is set to 0V with the result that the toner is moved to the high potential until at last it is deposited on the Transfer Roller. Toner is removed from the Transfer Roller by the attached cleaning blade and deposited in the attached waste toner reservoir.

Print Process Components

The relative position of the components involved in the printing process, the tray and duplex paper paths, and numbered references to the "Print Process Block Diagram" on page 2-2, appear in the following figure.

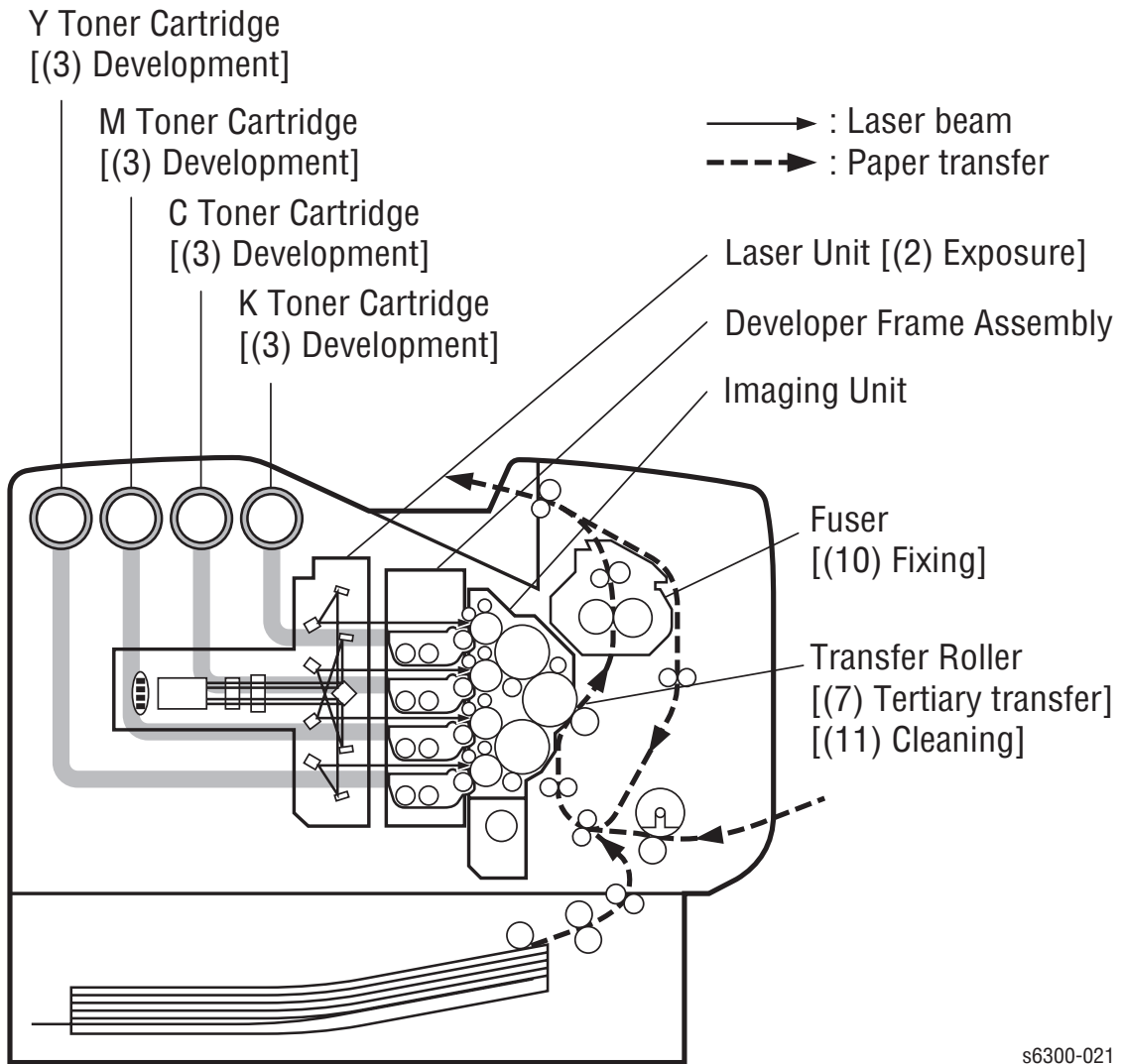

The Developer Frame Assembly, Imaging Unit, and numbered references to the "Print Process Block Diagram" on page 2-2, are detailed in the following figure.

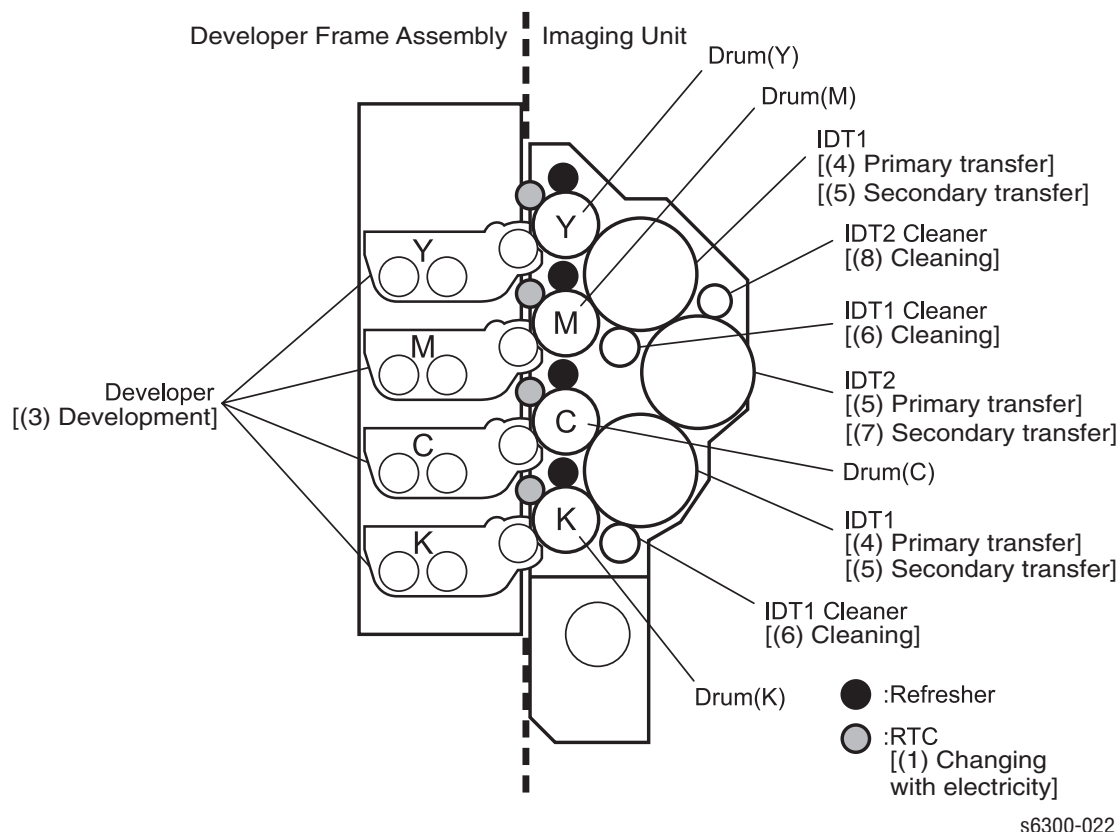

Print-Quality Modes

There are four print-quality modes:

| Print-Quality Mode | Description |
|--------------------|---|
| Automatic | Automatically selects the optimal print-quality mode for the paper type selected. For example, Photo print-quality mode is used when printing on Glossy Paper and Standard print-quality mode is used when printing on Plain Paper. (This setting is only available in the printer driver.) |
| Standard | 1200 X 600 dpi resolution. High-speed, general-purpose mode for crisp, bright, color prints. Recommended for most office use and quick prints. |
| Enhanced | 2400 X 600 dpi resolution. High-quality mode for fine lines and detail. Recommended for vibrant, saturated, color prints. Balances printing speed with quality. |
| Photo | 1200 X 1200 dpi resolution. Highest-quality mode for color prints and smoothest light colors. Recommended for photographs, smooth shaded drawings, and vibrant color. |

Printer Controls

Paper Size Control

The paper size detection for Trays 2, 3, 4, and 5 is determined by three paper size switches located in each paper tray slot. The switch condition is set by moving the paper guide in the tray. This in turn sets the plastic “fingers” on the side of the paper tray to a specific position that activates the correct switch combination for the selected paper size.

Paper Size Switches Indicated as SW1, SW2, and SW3

| Paper Size | Paper Size Switch | | |
|---|-------------------|-----|-----|
| | SW1 | SW2 | SW3 |
| LEGAL14" | On | On | On |
| US FOLIO (LEGAL 13)" | On | On | Off |
| EXECUTIVE | On | Off | On |
| B5 | On | Off | Off |
| A4 | Off | On | On |
| A5 (for reference, supported in Tray 1(MPT) only) | Off | On | Off |
| LETTER | Off | Off | On |
| No Tray | Off | Off | Off |

Selective Control; Paper Pick

Unless changed in printer setup, the default tray is Tray 2. Trays in the optional 1100-Sheet Feeder are identified as Tray 3 and Tray 4. The tray in the optional 550-Sheet Feeder is identified as Tray 3. If both optional Feeders are installed, the 550-Sheet Feeder tray is identified as Tray 3, and the trays of the 1100-Sheet Feeder are identified as Tray 4 and Tray 5.

Note

The Phaser 6300/6350 printer supports the installation of only one 550-Sheet Feeder. Attempting to install a second results in an unsupported configuration error.

Laser Light Intensity Control

The Laser Unit in the Phaser 6300/6350 printer has four laser diodes: one each for yellow, magenta, cyan, and black. The diode control circuitry adjusts the light intensity for each color automatically. Image data is transmitted to the laser diodes in the Laser Unit as digital signals. The laser diodes convert the image data from digital signals to optical signals. The Laser Unit monitors and adjusts the intensity of the laser beams to attain a stable electrostatic image.

The data path of image data is shown in the following figure.

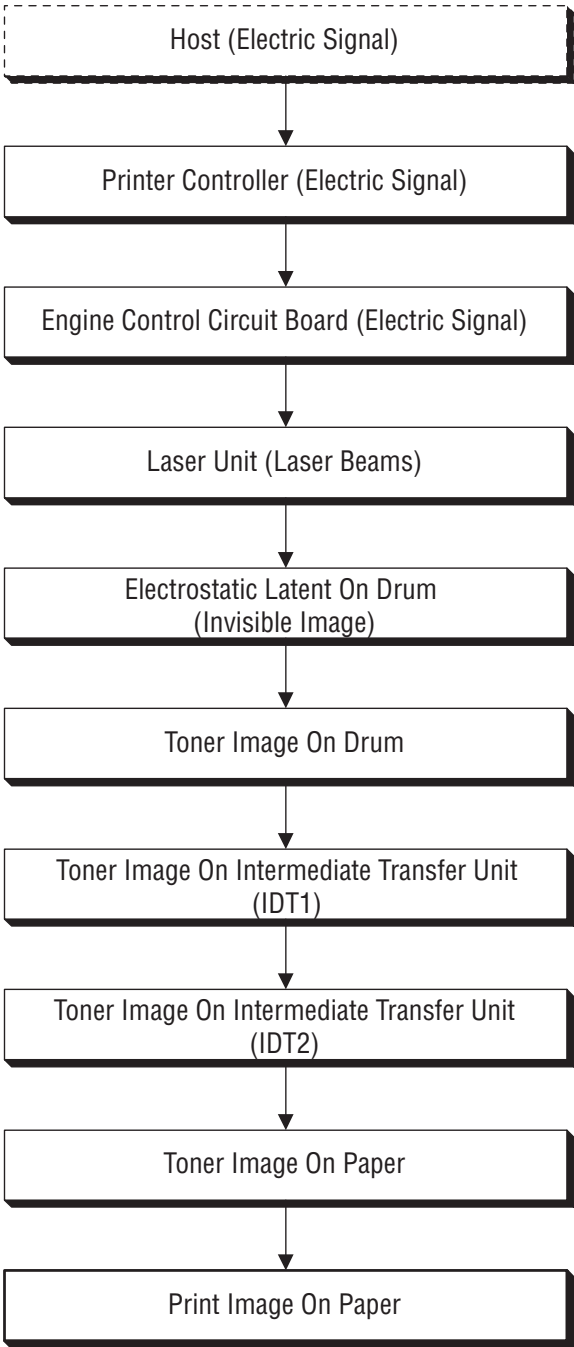

s6300-043

Process Control

For stable printing, the parameters related to forming both the electrostatic and toner image are continuously monitored and adjusted by the printer. Parameter correction and control over the entire printing process is called “process control”. There are two main areas of control:

- Bias Control
- Toner Density Control

To supplement these two controls, the following are provided:

- High-Area Coverage Mode Control
- Admix Mode Control
- Toner Density Control (CTD) Sensor (ADC - Automatic Density Control) LED light density setting.

Bias Control

To attain stable image density, toner density is monitored for each color and the drum charging voltage and biasing DC voltages are adjusted accordingly.

The bias control adjustment is made immediately before the start of printing, if any of the following conditions is satisfied:

- First print produced after the power on.
- Cumulative print count exceeds 16 since power on.
- A cleaning cycle is executed during continuous printing.

Bias control operates as follows:

1. The Temperature/Humidity Sensor provides input to establish target values of the drum charging voltage and biasing DC voltage.
2. Bias control test patches (see the adjacent figure for patch configuration) of each of the four toner colors (yellow, magenta, cyan, and black) are generated and transferred to the Transfer Roller.
3. The CTD (ADC) Sensor compares an area on the Transfer Roller where no toner is present with the test patches to determine toner density for each of the four colors.
4. The density measured in Step 3 is compared with the target value set in Step 1 and the resulting difference is used to adjust the drum charging voltage and the biasing DC voltage for each toner color.

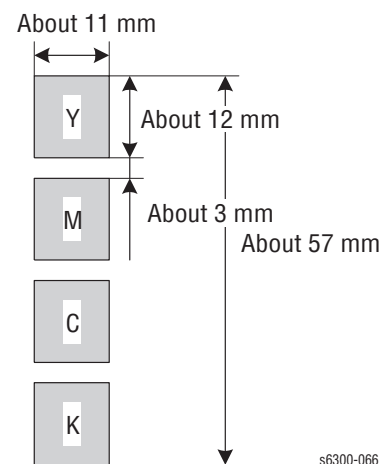

Toner Density Control

Toner density is kept constant to maintain a stable print image. To achieve this, the rate at which toner is dispensed is adjusted to exactly match the rate at which it is consumed. There are two systems that work together to control toner density: the Pixel Count Dispense Control (PCDC) and the Toner Density Control (CTD). (The CTD uses data from the ADC sensor, measured as described in the preceding paragraphs covering bias control.)

PCDC: The amount of toner consumed in the developing process is determined by counting the digital pulses applied to the Laser Unit as part of the Image data transfer. Based on this count, the toner motor is driven to dispense an equivalent amount of toner to compensate for the loss.

CTD (ADC): Toner test patches of each color (yellow, magenta, cyan, and black), are generated and applied to the Transfer Roller as described in the Bias Control discussion. The CTD (ADC) Sensor is used to measure the density of each patch. The CTD (ADC) Sensor signal indicates how much to adjust the toner dispense time (Toner Motor rotation) for each color. The CTD adjustment is made following completion of printing under either the following conditions:

- Cumulative print count since power on exceeds 16 pages.
- When a cleaning cycle is executed during continuous printing.

If an adjustment to the toner quantity is necessary, a Dispense Count is calculated and executed as a specific number of Toner Motor rotations.

The Dispense Count is implemented over the next eight prints. For example, if the Dispense Count is 16, two dispense counts are added during each of the next eight prints. This is in addition to any counts added or subtracted during each print as a result of PCDC.

If the CTD (ADC) Sensor indicates that toner density is too high and that 16 Dispense Counts are required to return toner density to normal, the adjustment is accomplished by subtracting two counts from the calculated PCDC count over each of the next eight prints. If the excess amount cannot be subtracted in 8 print cycles, it is subtracted in the ninth and subsequent prints. The following figure illustrates this process.

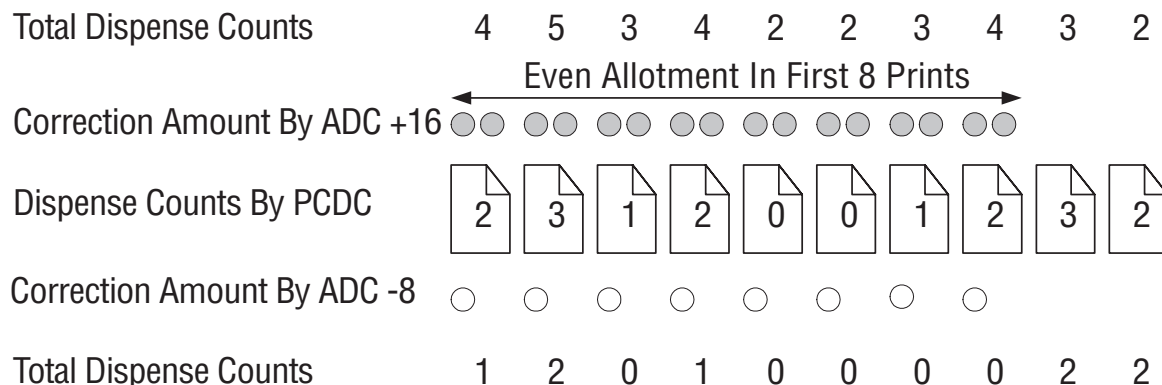

s6300-067

High Area Coverage Mode

The High Area Coverage mode delays page feeding giving the printer additional time to dispense toner. This mode compensates for images whose toner density exceeds the printer's toner dispense capabilities. This typically occurs during continuous runs of images that drop the toner density for any color Developer below the reference value.

Admix Mode

If High Area Coverage mode fails to compensate for the reduction in Developer toner density, or if the printer is moved to an environment with a different humidity level changing the reference value, Admix mode dispenses toner immediately to restore toner density levels if needed.

LED Light Density CTD (ADC) Control Sensor

The CTD (ADC) Sensor is a photo-reflective sensor that emits light from an LED and detects the reflected light returning from the Transfer Roller. The CTD (ADC) Sensor reference voltage (reflected light density) is established when both the sensor and the Transfer Roller are clean and free of defects. The light emitted from the LED is controlled so that the reflected light density meets the reference value.

LED light emission control is implemented in two ways:

- Sets the light density so that the light reflected satisfies a specific value.
- Adjusts the subsequent light density to be within a specific tolerance value.

1. Light Density Setting

The reflected light density can vary greatly if the Transfer Roller has just been replaced or the CTD (ADC) Sensor has just been cleaned, or is dusty with waste toner. To compensate with this variance, the light density is reset each time the power is turned on or a door is opened.

When the output of the CTD (ADC) Sensor does not meet the reference value, the intensity of the LED light emissions are increased gradually and the Light Density Setting is adjusted. If the light density is increased to the maximum and output of the CTD (ADC) Sensor does not reach the reference value, a warning message indicates the sensor is dirty. If the sensor output remains above the reference value, a fatal error reports that the sensor is faulty.

2. Light Density Adjustment

At the execution of Automatic Density Control, the Light Density Adjustment is made just before the toner patches for toner density control are generated.

Light is emitted from the LED using the current Light Density Setting, to check if the output value of the CTD (ADC) Sensor is within the specified range. If the output value is low, light density is increased. If the output value is high, light density is decreased.

If the output value is less than the first lower limit, a warning message indicates the sensor is dirty. If the output value is less than the second lower limit, a Fatal Error signals that the sensor is faulty and the printer stops printing.

Color Registration Control

The printer uses a quad system where drums and developers are used exclusively for each of the four colors (yellow, magenta, cyan, and black). Images are formed on the drums, in the respective colors, and then layered to form one image. To avoid a positional shift between the different color images, the color registration control calculates how much the registration has shifted by comparing each of the other color patches in the registration string to the black bar that precedes it. Shift is corrected by adjusting the laser write timing to compensate.

Color registration control is made depending on the internal temperature and print count at the execution of process control.

This control is outlined below:

1. With no toner on the Transfer Roller, the output value of the CTD (ADC) Sensor is measured to determine the reference value.
2. Patches for color registration control are generated on the Transfer Roller. These patches are composed of 10 mm lines of each toner color in the following order: K, C, K, M, K. The string of patches is led by a black trigger patch that is larger than the registration patches.
3. The density of patches generated is measured by the CTD (ADC) Sensor.
4. The amount of registration shift is calculated from the reference value determined in Step 1 and the patch density measured in Step 3.
5. The laser write timing is changed to compensate for any registration shift.

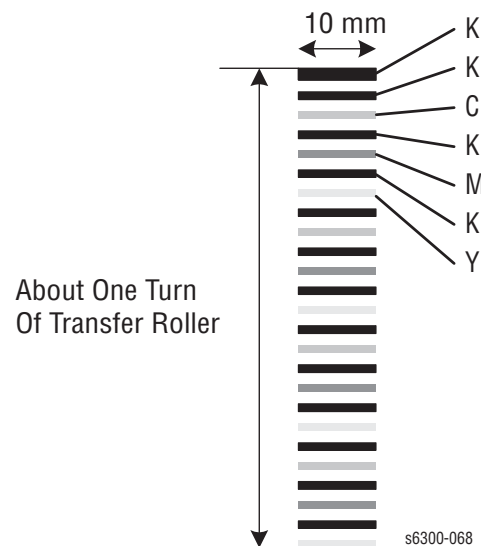

Transfer Roller Control

Detecting the Transfer Roller

The CTD (ADC) Sensor is used to detect the presence of the Transfer Roller. This determination is made whenever power is turned on, or a door is opened and closed.

If the output of the CTD (ADC) Sensor is greater than the reference value the controller signals that the Transfer Roller is present. If the sensor output is lower than the reference, a Fatal Error indicates that the Transfer Roller is not installed.

If printing is stopped by a jam, a latent image remains on the Transfer Roller. To prevent a false error, the controller rotates the Transfer Roller a half turn. If the sensor output remains below the reference, a Transfer Roller missing error is generated. Otherwise, the sensor output indicates that the Transfer Roller is present and no additional error is reported.

Detecting Transfer Roller Life

The Transfer Roller consists of a bias transfer roller and a waste toner recovery space. Transfer Roller end of life occurs when the Toner Full Sensor detects that the waste toner recovery space is full.

1. Status of the waste toner reservoir is checked:
 - When the power is turned on.
 - When a door is opened and closed.
 - When paper exits the print engine.
2. Transfer Roller is at End of Life warning message is generated when the Toner Full Sensor detects the waste toner reservoir is full.
3. Replace Transfer Roller error message is generated if the print count and the toner dispense time are counted and the total count exceeds 15,000 prints.
4. Transfer Roller is at End of Life warning and Replace Transfer Roller error messages are reset if the Toner Full Sensor does not detect a full waste toner reservoir when power is turned on, or a door is opened and closed.

Toner Control

Toner Cartridge presence is detected by a combination of the Toner Sensor Actuator and CRUM Reader. Presence of toner in the cartridge is detected by the No Toner Sensor. These sensors are provided for each toner color (CMYK), and detection is made for each individually.

No Toner Sensor

The No Toner Sensor located on each Toner Cartridge Holder checks one color every 3.5 seconds, requiring 14 seconds to detect all four colors. The sensor detects toner as it's dispensed from the toner cartridge into the auger tube.

To prevent false errors resulting from toner obscuring the sensor, a film attached near the auger in the Toner Cartridge Holder cleans the sensor surface whenever toner is dispensed. False errors related to toner detection are avoided by the printer's internal Toner Presence Control.

Toner Presence Control

1. Checks for toner presence when the power is turned on, or after a door is opened and closed. Checks every 14 seconds when printing.
2. The "Replace [CMYK] Toner Cartridge" error displays when the counter on the Customer Replaceable Unit Monitor (CRUM) indicates that the toner is empty.
3. The "Replace Toner Cartridge" error displays when the No Toner Sensor detects that a cartridge is empty.
4. When a new Toner Cartridge is installed prior to receipt of a "Replace Toner Cartridge" error, toner is dispensed for 1.7 seconds. At the next toner presence control sampling, if the No Toner Sensor detects toner present, all Toner "Warnings", and "Errors" are reset. When toner is dispensed and the No Toner Sensor detects toner present three or more times consecutively, the controller regards this status as "Toner Present".
5. If the No Toner Sensor does not detect toner, toner is dispensed for 1.7 seconds again 5 seconds later. If toner present is not detected after executing toner dispense three times and if Toner Cartridge dispense time is 0, the "Remove Ribbon From 'x' Cartridge" error displays.

Fuser Control

Fuser Temperature Control

During Fuser temperature control the printer's target temperature is set based on the media type. The Heat Roller surface temperature is controlled to match the target temperature by turning the heater lamp On and Off.

The Heat Roller surface temperature is detected by two sensors. A Non-Contact Sensor (NCS) in the middle of the roller and the Temperature Sensor at the edge of the roller. These sensors are checked every 10 ms to maintain an even temperature across the Heat Roller. If the readings indicate the temperature is higher than the target, the heater lamp is turned Off. If the readings fall below the target temperature, the heater lamp is turned On.

For the target temperature, different temperatures are set for standby, printing, and process control. The target temperature is also changed according to the inside temperature detected with the Temperature/Humidity Sensor, print count, print mode, input power supply voltage and paper type.

Cool Down

During printing, the temperature distribution of the Heat Roller becomes uneven. To compensate, a wait time is provided and the heater lamp is kept Off. When Heat Roller temperature stabilizes, printing resumes.

Paper Path of the Printer

Paper path components and routing for the printer and the optional 1100-Sheet High-Capacity Feeder are shown in the following figure.

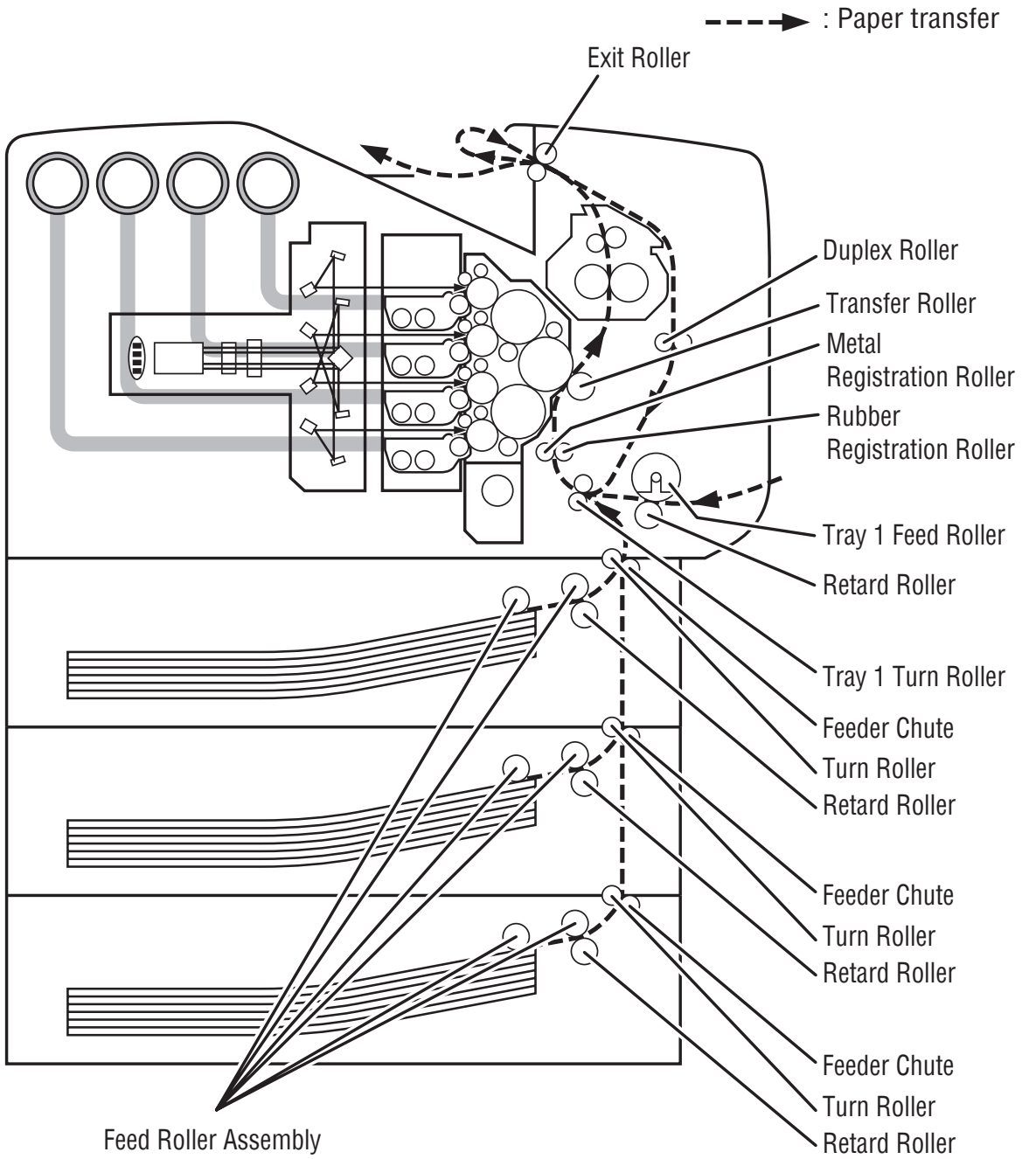

s6300-078

Paper Path Route

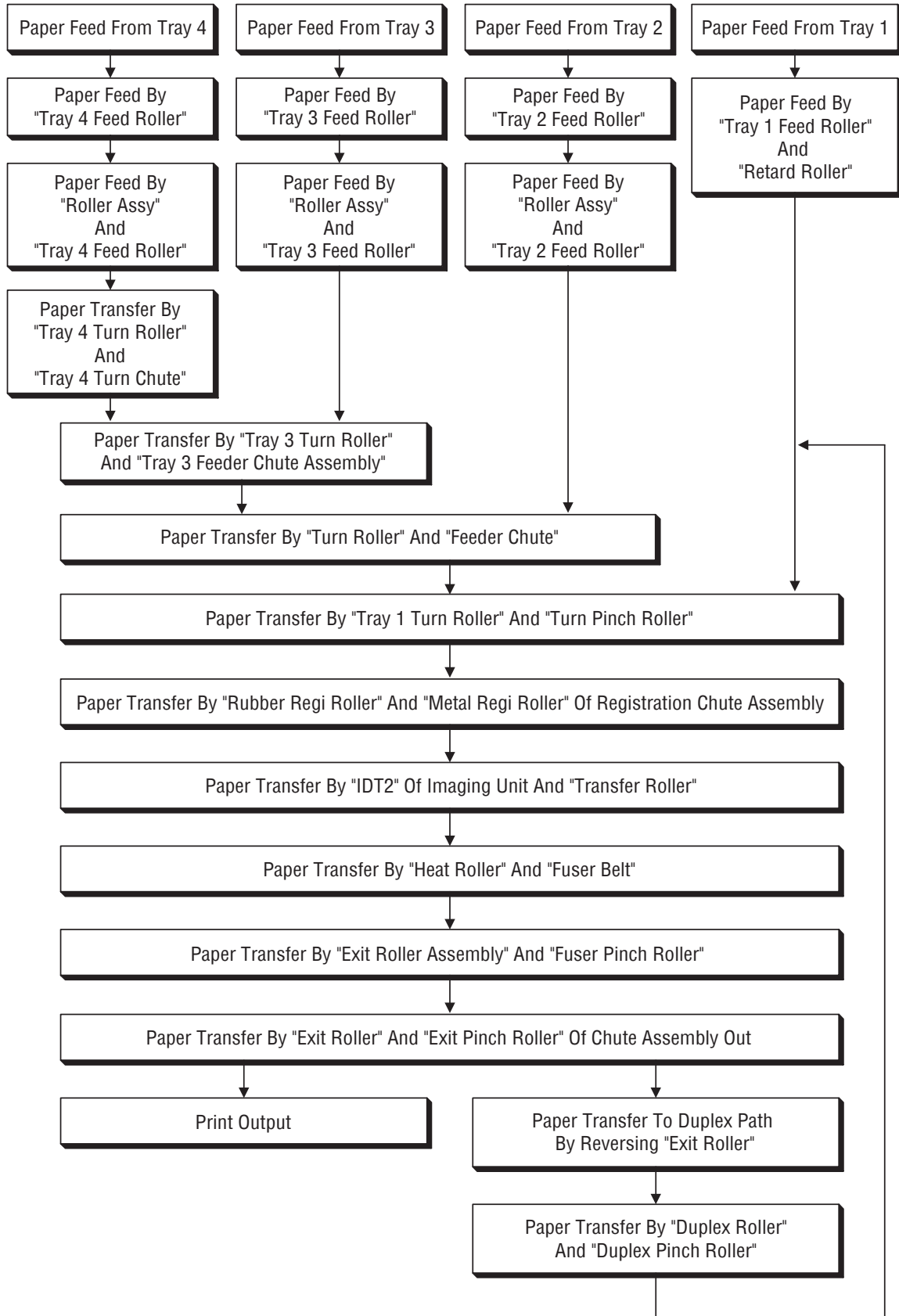

s6300-077

Sensors

The printer contains sensors of various types that perform a variety of functions. One group of sensors track the progress of the paper along the paper path, and detects if a paper jam occurs. Other sensors detect the presence of the Toner Cartridges, stop printer activity if a door is open (interlock), detect the presence and size of media in the trays, and monitor the fusing temperature.

Sensor Types

The types of sensors used vary with function. In general, there are three types in use:

Photo Sensors

Two types of photo sensors are used, photo-reflective and photo-receptive. Photo-reflective sensors use light reflected back from an object to detect its presence. Photo-receptive sensors use an actuator or the object itself to block the light path to detect an object or condition.

Photo-reflective sensors have the light emitter and light receiver aligned on a single surface. Output of the photo-receptor is High ($> +4.5$ V) when light is being reflected back and Low ($< +3$ V) when it isn't. Photo-receptive sensors consist of a LED in one arm of a U-shaped holder, and a photo-transistor in the other arm. When the sensing area is vacant, nothing is between the arms of the sensor, light falls on the photo-receptor sending the signal High. If the light is interrupted, the photo-transistor goes Low.

Microswitches

Microswitches are used primarily as paper size sensors and cover interlocks. They are in a normally open state, and close when actuated. A bank of microswitches is used to detect paper size in the universal trays. Microswitches also employ hooks or catches for retention in the bracket or frame.

Thermistors

Thermistors have a known value of resistance whose value varies with temperature. Used primarily in the Fuser for temperature sensing.

Sensors in the Paper Path

The following illustration identifies the various sensors located along the paper path. Error reporting is dependent on these designators. Error detection is based on paper transport timing through the sensing area.

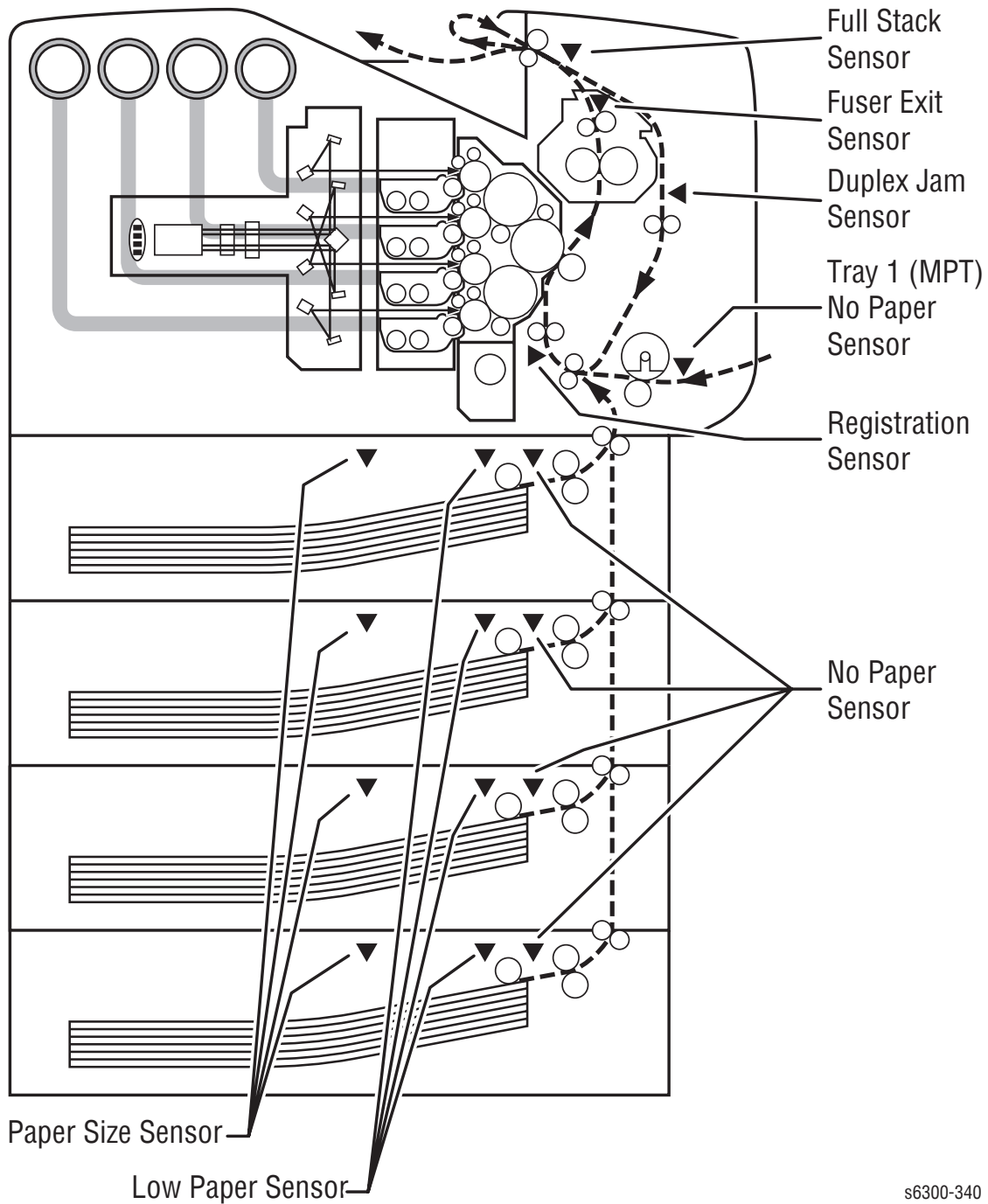

s6300-340

Paper Path Sensor Locations

The following diagrams show the relative position of sensors located along the paper path.

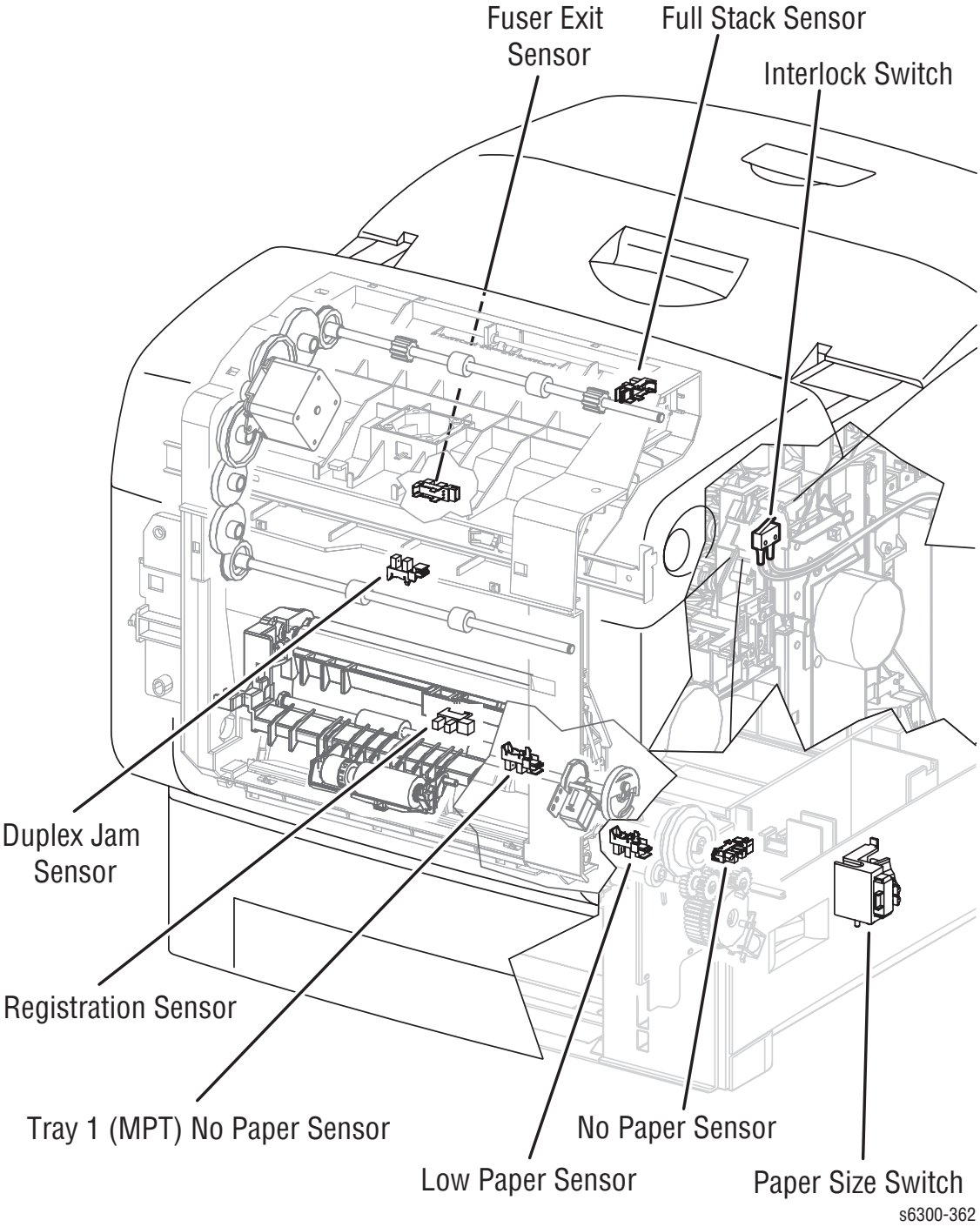

Xerographic Sensor Locations

The following diagrams show the relative position of xerographic sensors.

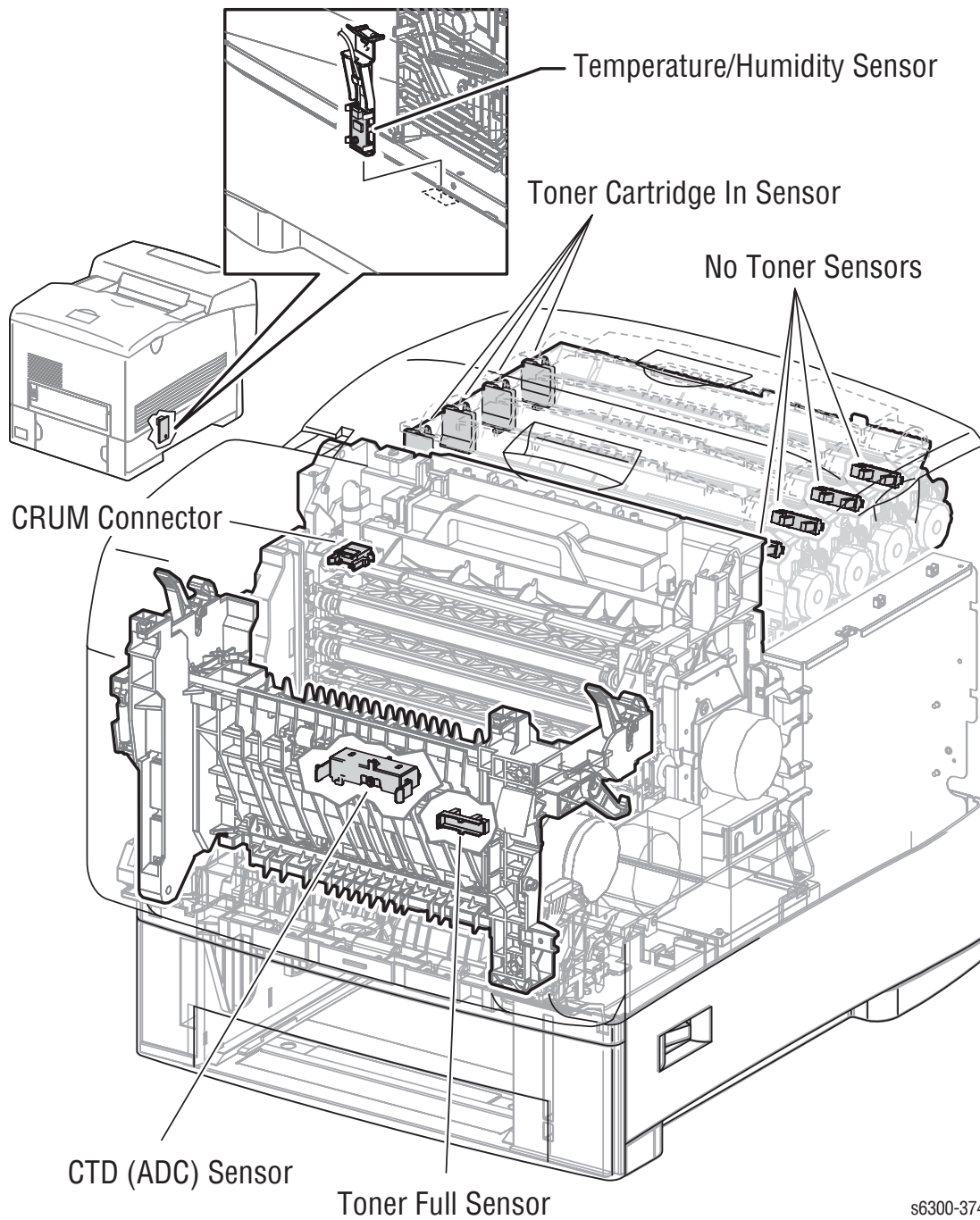

s6300-374

Print Engine Assemblies

The following section describes the major functional components of the print engine.

Drive Assemblies

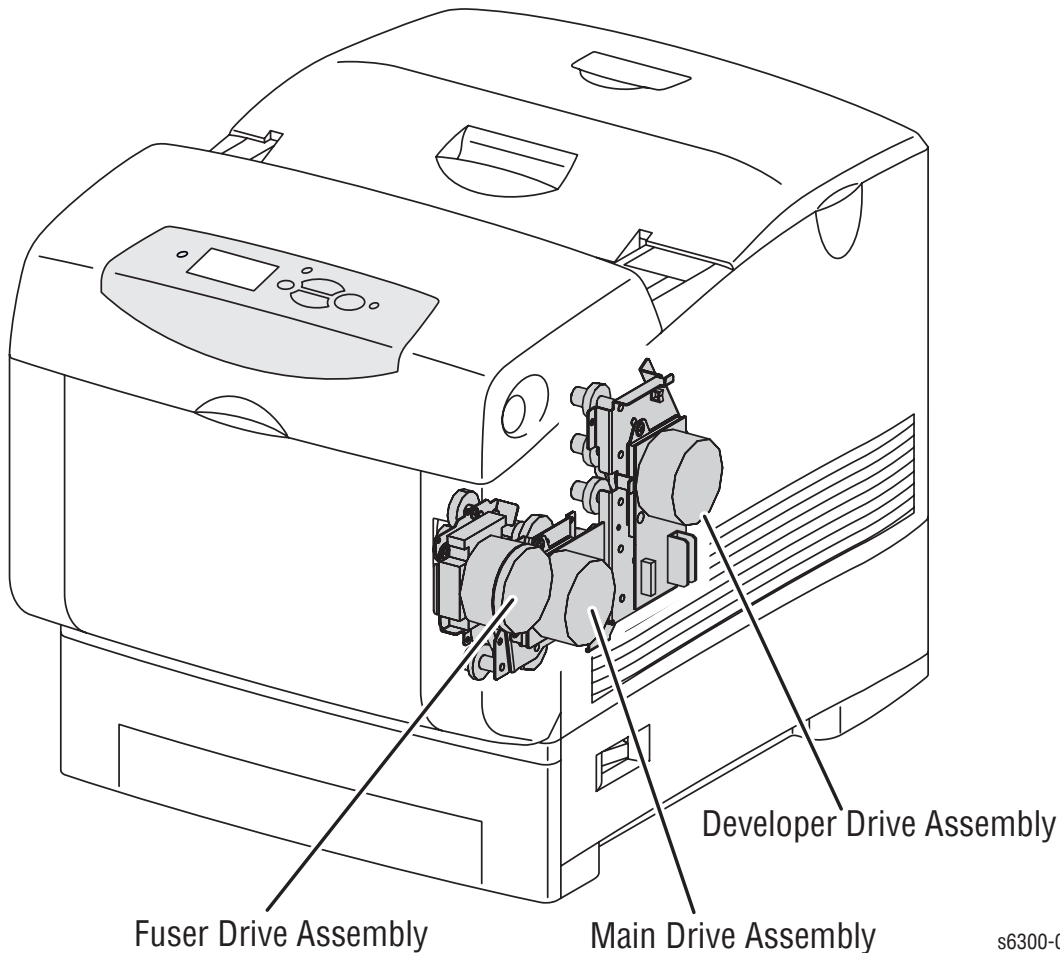

- Developer Drive Assembly
Drives the Developer Frame Assembly.
- Main Drive Assembly
Drives the following parts:
 - Paper Pick Assembly
 - Chute Assembly Out (MPT position)
 - Registration Roller Assembly
 - Tray 1 (MPT) Retard Roller
 - Imaging Unit
 - Transfer Roller
- Fuser Drive Assembly
Drives the Fuser Assembly.

Developer Drive Assembly

The Developer Drive Motor drives the four developers housed in the Developer Unit. The drive transmission route differs depending on the print mode. For monochrome printing, the developer for the K drum is activated as shown in the following figure.

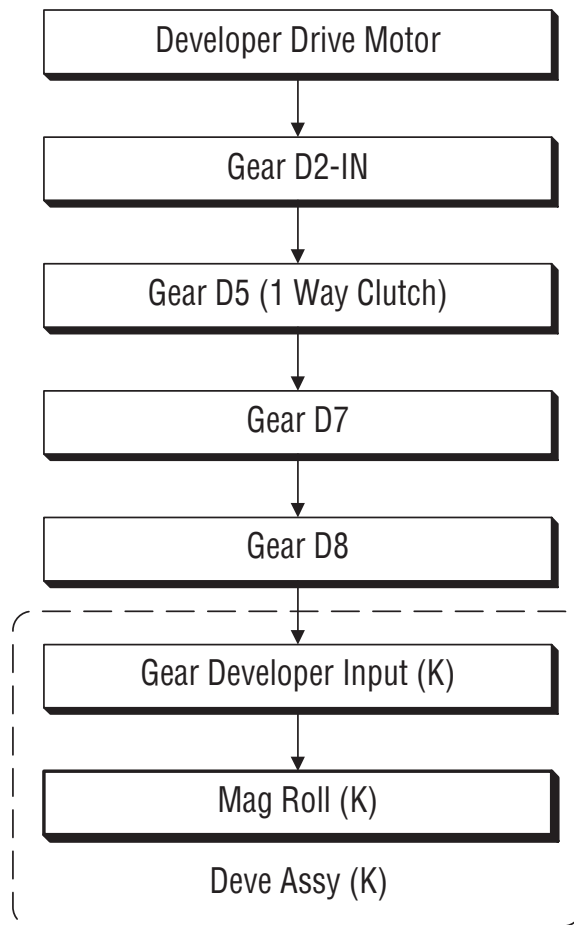

s6300-342

The following figure shows the relative positions of the gears being driven during monochrome printing.

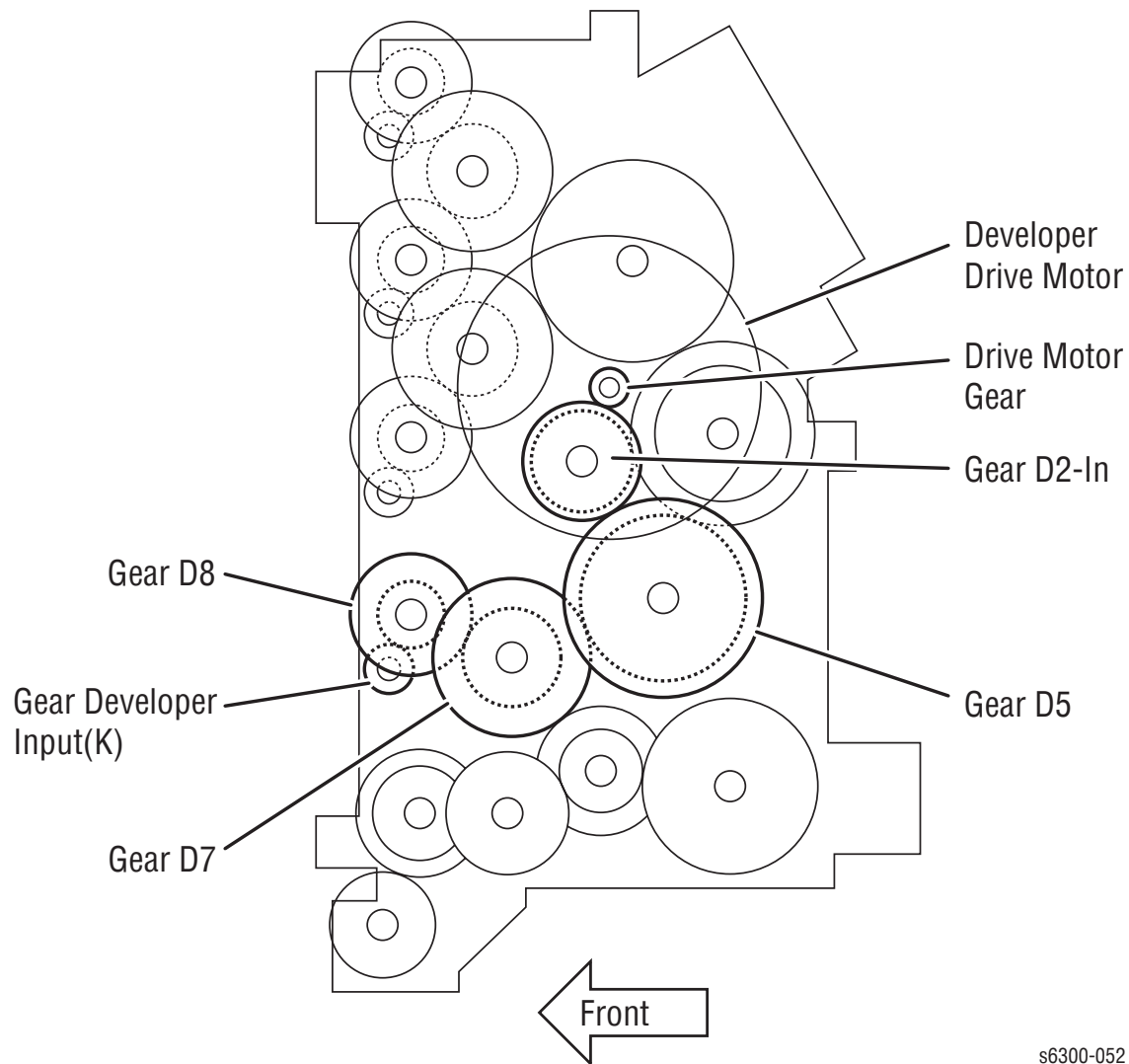

s6300-052

When printing in full color, the Developer Drive Assembly uses a series of gears to drive all four developers to support the Y, M, C, and K drums. The following figure diagrams the transmission path of the Developer Drive Assembly in full color printing.

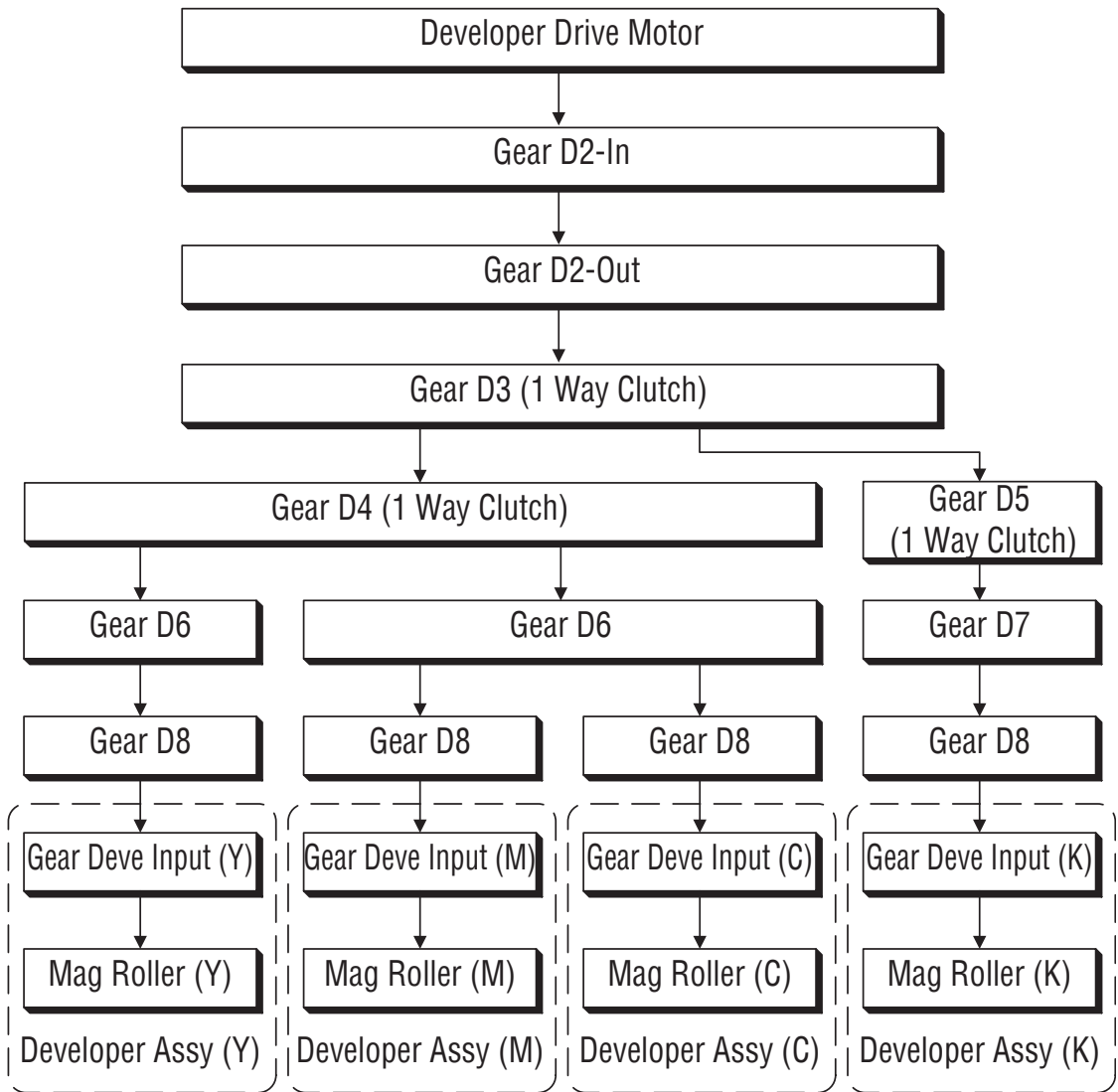

s6300-045

The following figure shows the relative positions of the gears being driven during full color printing.

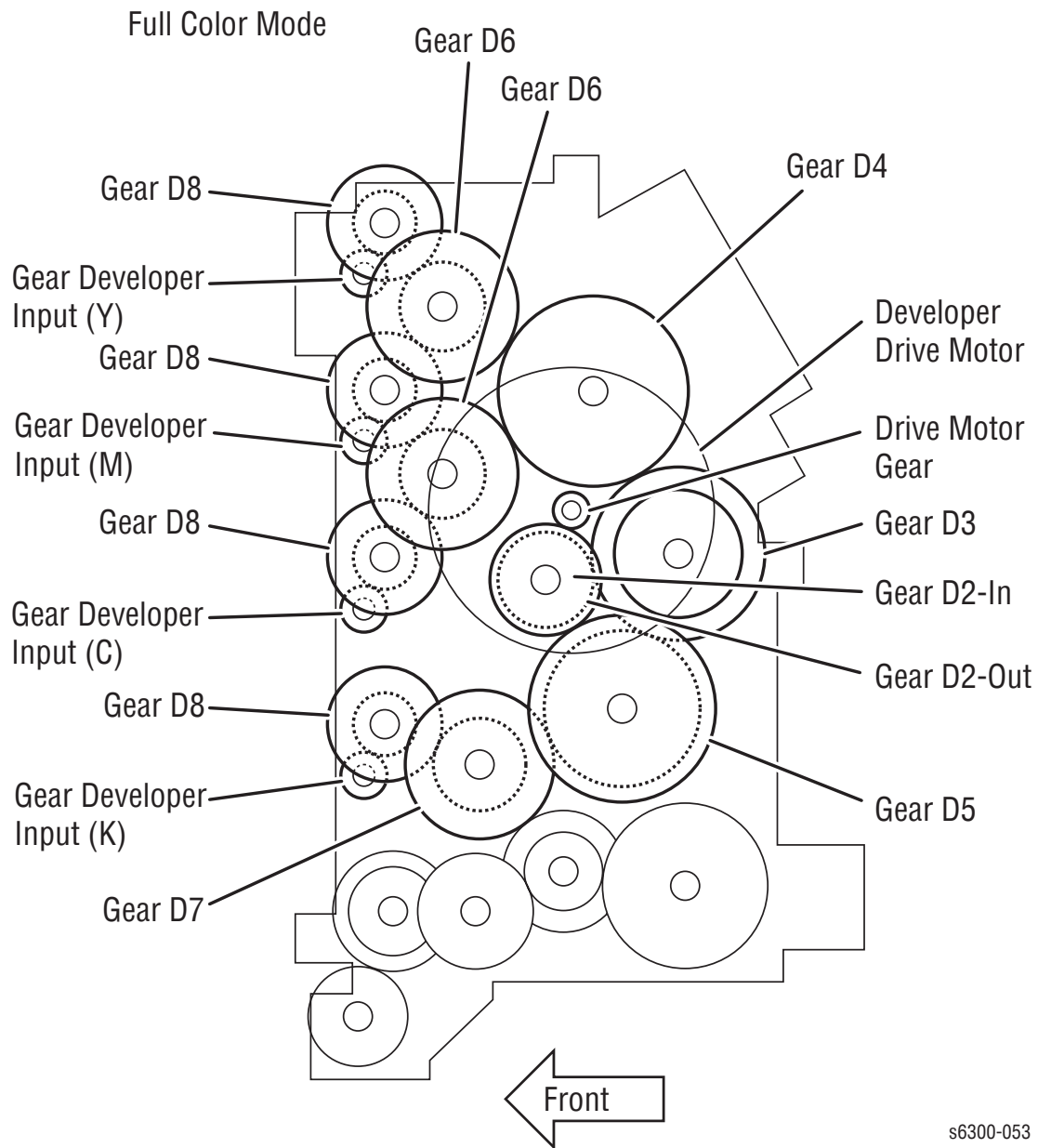

Main Drive Assembly

The Main Drive Motor drives the Imaging Unit, Transfer Roller, Registration Chute, and paper feed. The following figure diagrams the relationship of the Main Drive Motor, the gear set, and printer functions.

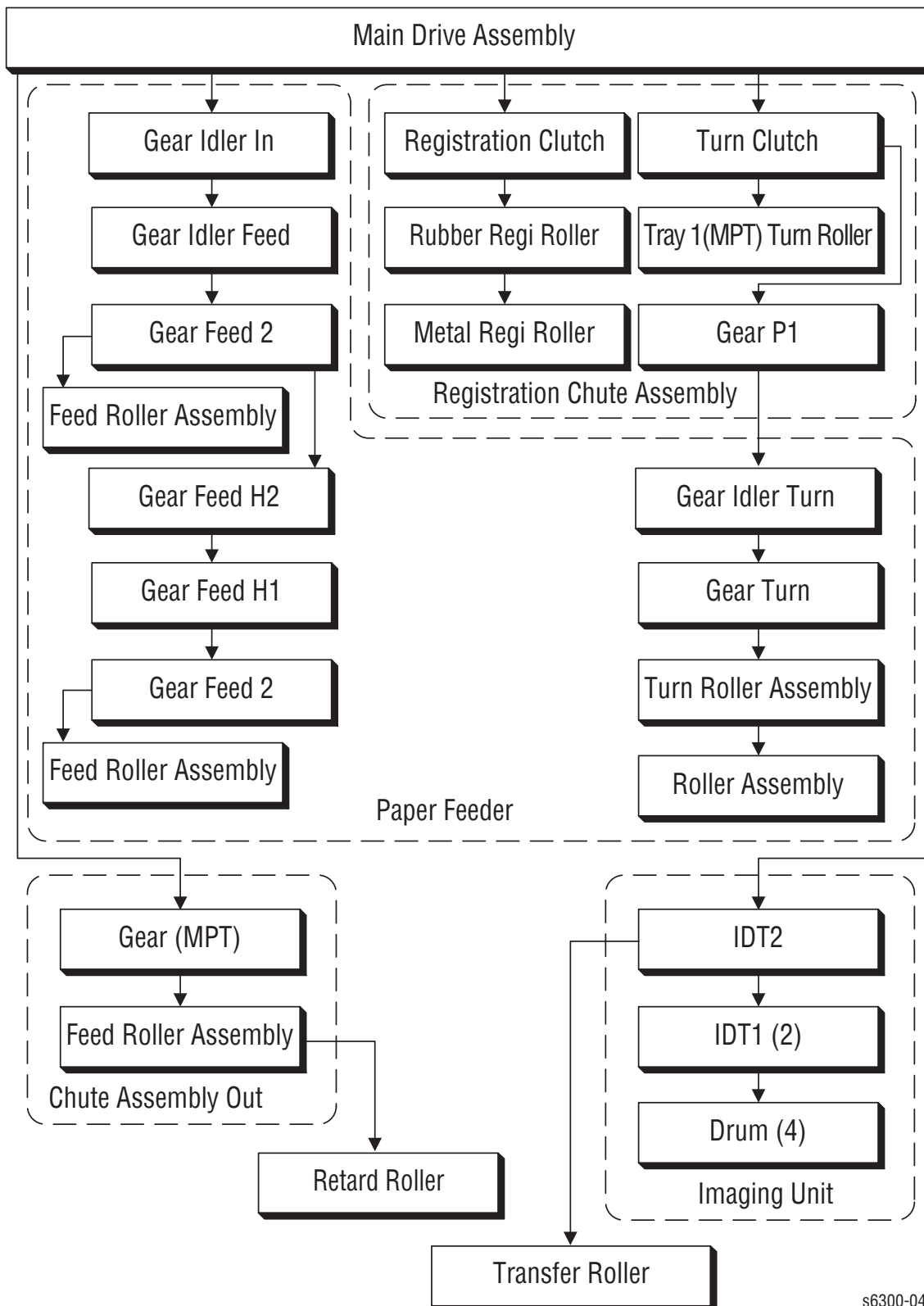

s6300-044

The figure below shows the location of the various components driven by the Main Drive Assembly.

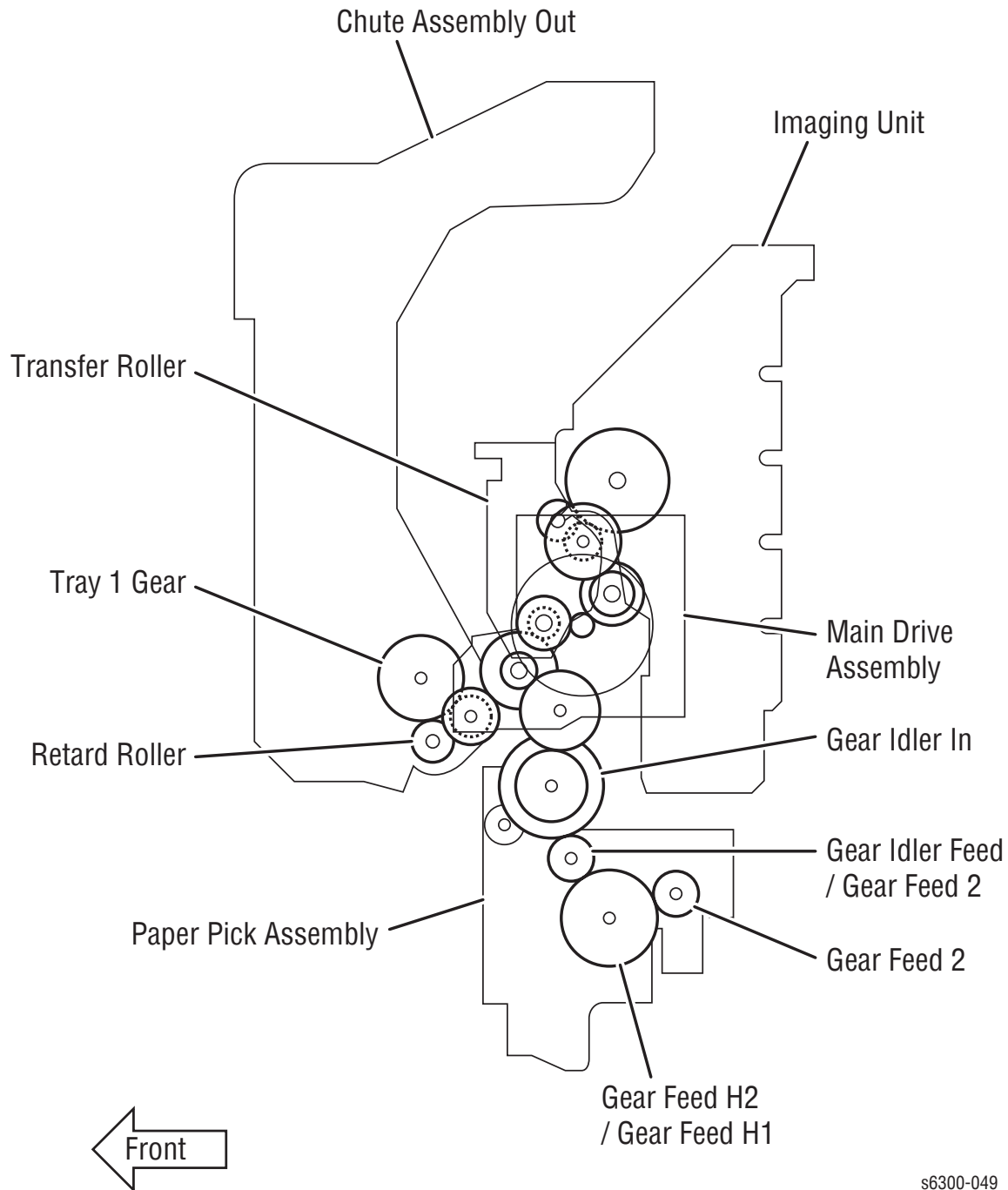

s6300-049

A number of other motors are used to drive rollers, move paper, and supply toner. These motors are described in detail in subsequent sections that highlight printer function in more detail.

Fuser Drive Assembly

Supplies the drive to the Fuser as shown in the following figure.

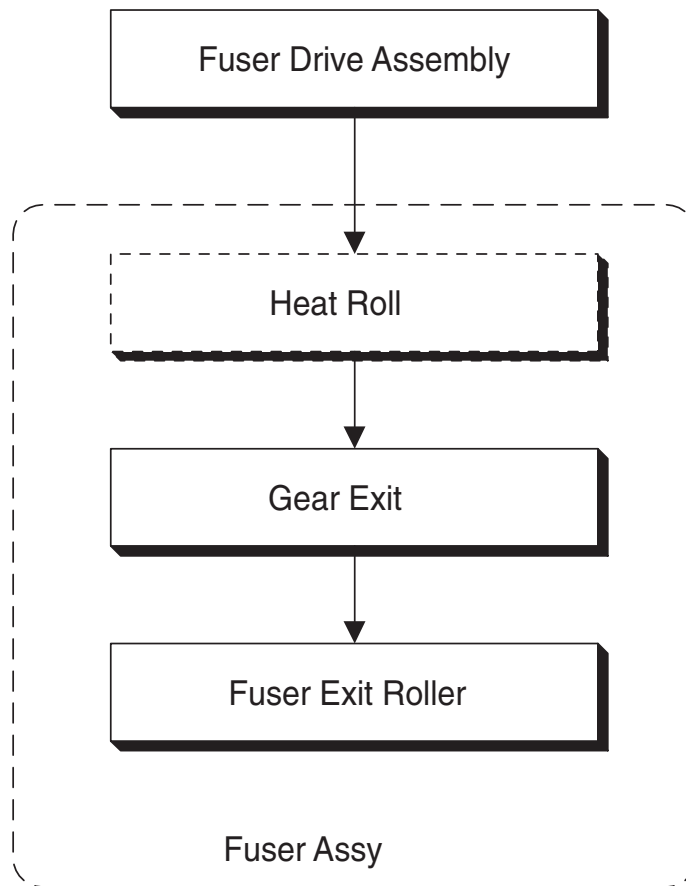

s6300-343

Registration Roller Assembly

Shown in the following figure are the components associated with aligning the paper in preparation for image transfer (Registration), and feeding paper from Tray 1 (MPT). The Registration, Turn and Retard rollers are driven by the Main Drive Motor.

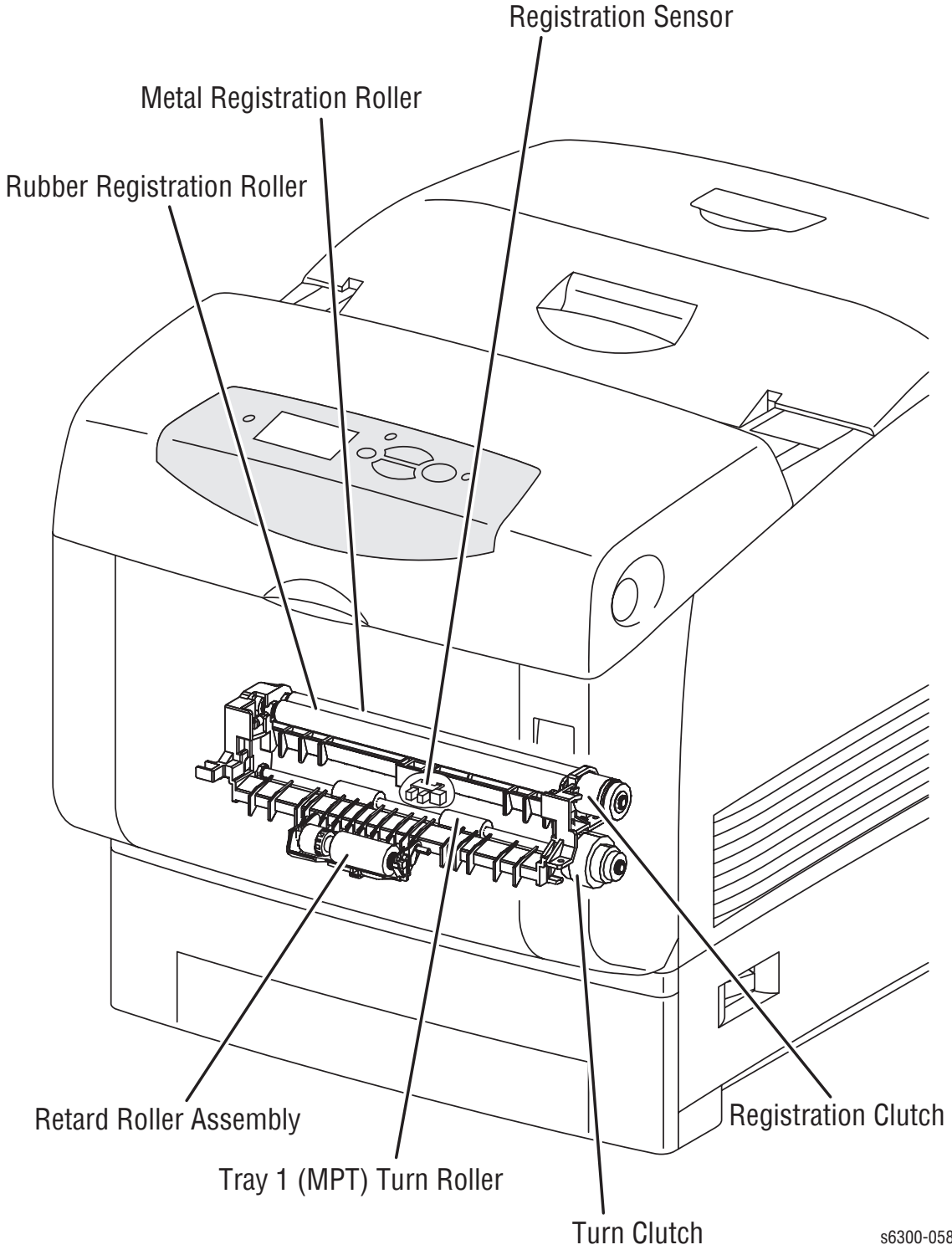

s6300-058

- **Registration Sensor**
Detects the when the media's leading edge has reached the Registration Chute.
- **Rubber Registration Roller**
Driven by the Main Drive Assembly through the Registration Clutch, the Rubber Registration Roller works with the Metal Registration Roller to correct media skew and transport media.
- **Metal Registration Roller**
Works in conjunction with the Rubber Registration Roller. When the leading edge of the paper arrives at the registration rollers, the rollers are not turning and the paper buckles against the rollers to correct any skew at the leading edge.
- **Turn Roller**
The Turn Roller is rotated by the Main Drive Assembly, through the Turn Clutch to feed paper from Tray 1 (MPT) to the Registration Chute.
- **Turn Clutch**
Transfers drive from the Main Drive Assembly to the Turn Roller through a friction clutch.
- **Registration Clutch**
Transfers drive from the Main Drive Assembly to the Rubber Registration Roller, and transports the paper from Tray 1 (MPT) and the duplex path toward the

Imaging Unit.

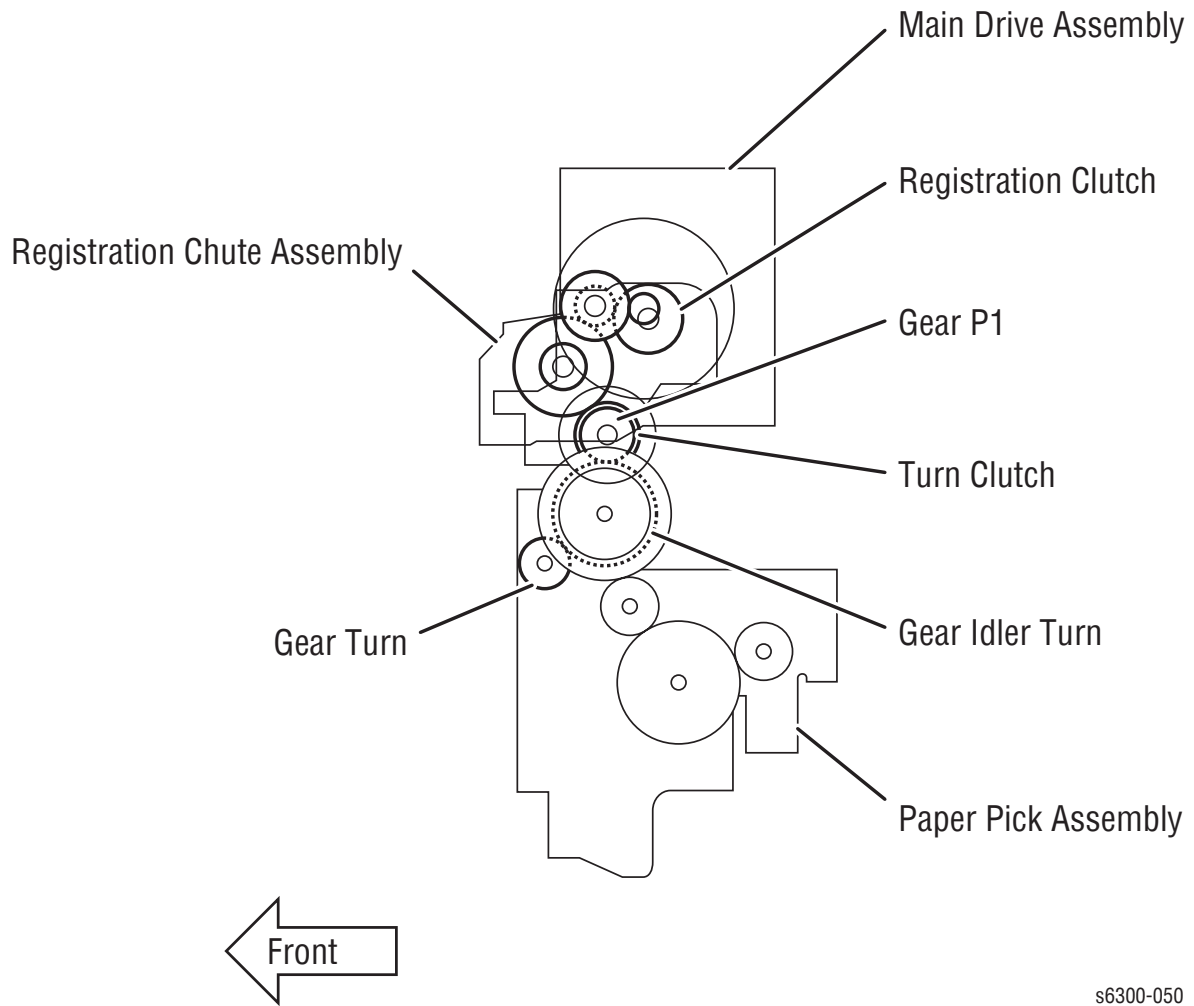

s6300-050

Chute Assembly In

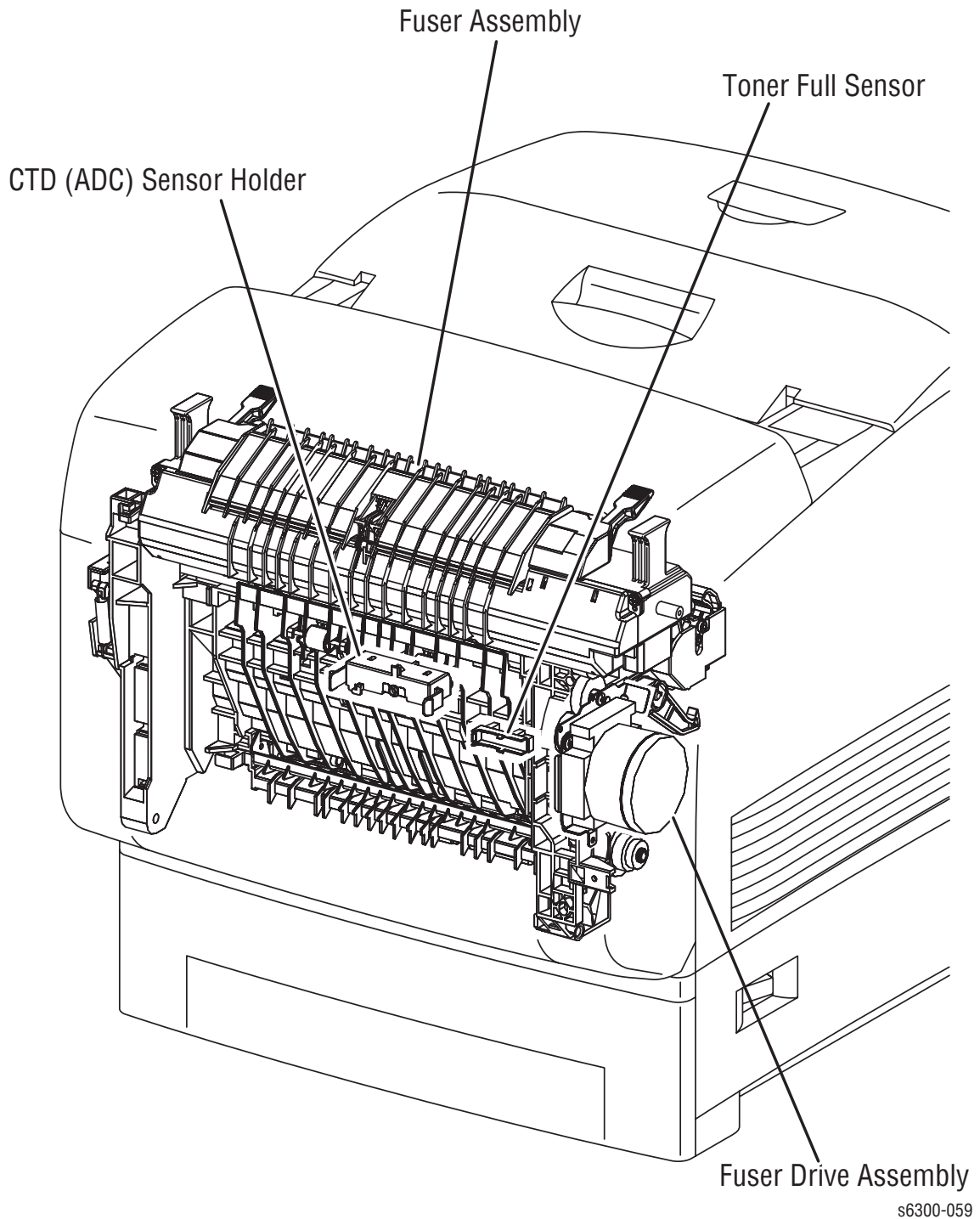

- CTD (ADC) Sensor
Checks image registration, detects the presence of the Transfer Roller, and monitors the density of toner on the surface of the Transfer Roller.
- Toner Full Sensor
Detects when the waste toner reservoir in the Transfer Roller is full.
- Fuser Assembly
Sets the image using pressure and heat to bond the toner to the media.

Chute Assembly Out

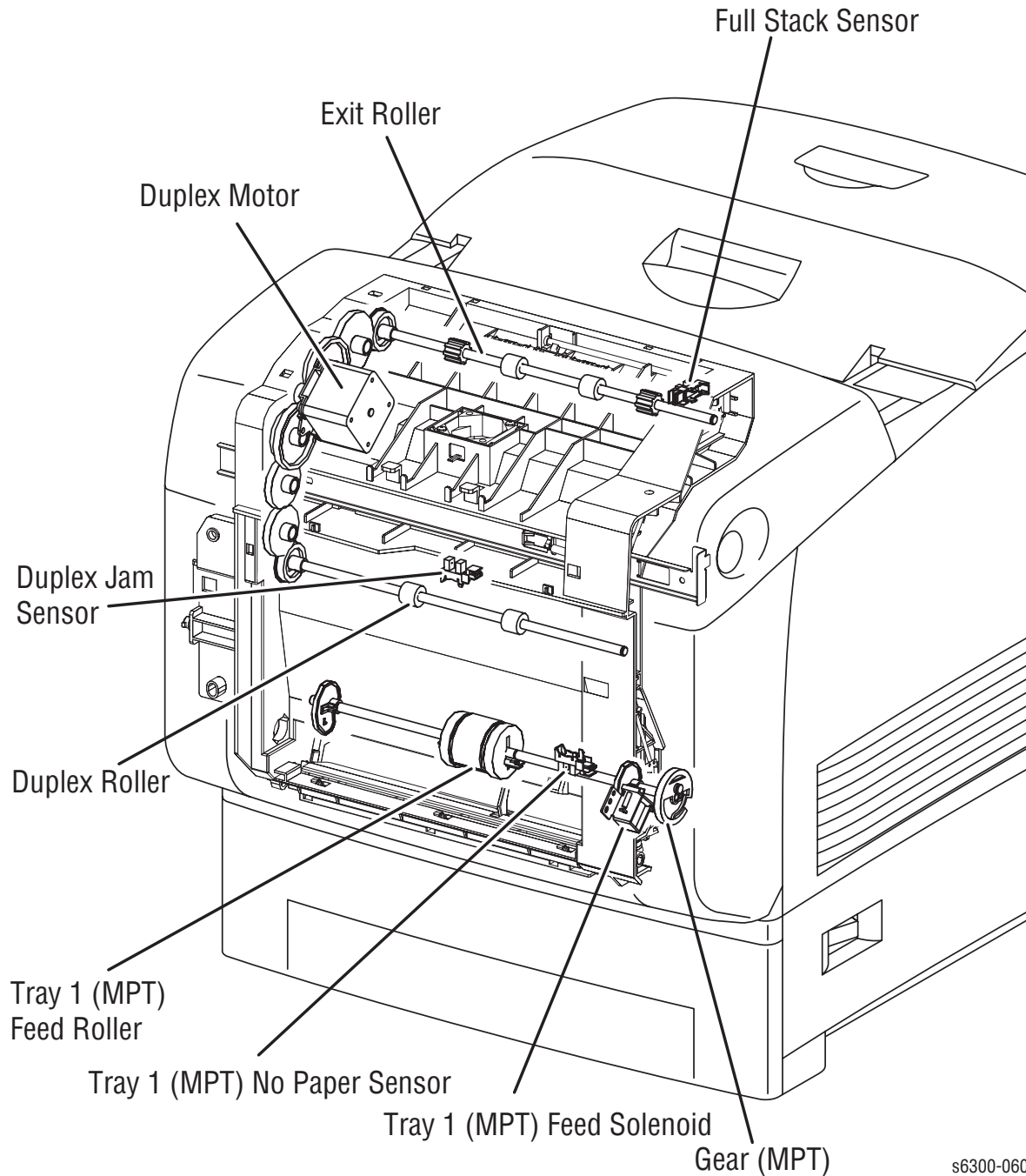

s6300-060

- Full Stack (Output Tray Full) Sensor
Detects a full output tray. This is only checked when paper is fed into the exit.
- Duplex Jam Sensor
Detects when print media has reached the Duplex Roller.
- Duplex Motor
Drives the Exit and Duplex rollers as shown in the following figure.

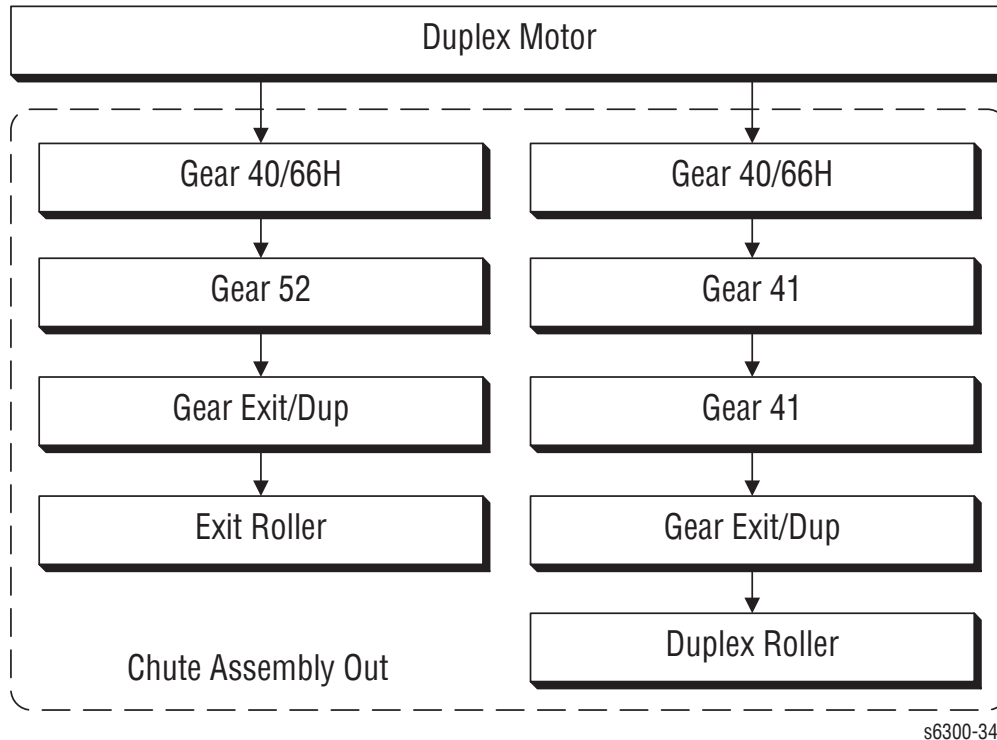

- **Duplex Roller**
Driven by the Duplex Motor, the Duplex Roller feeds the print media returned from the Exit Roller to the Turn and Retard Rollers.
- **Feed Roller**
When the Tray 1 (MPT) Feed Solenoid energizes, the Gear MPT and Idler gear are engaged. The Feed Roller rotates feeding paper from Tray 1. After rotating one turn, the Gear MPT and the Idler gear disengage, and the Feed Roller stops, allowing only one sheet of paper to be fed through at a time.
- **Tray 1 (MPT) No Paper Sensor**
Detects whether print media is present.
- **Tray 1 Feed Solenoid**
Controls the operation (rotation/stop) of the Tray 1 (MPT) Feed Roller.
- **Exit Roller**
Driven by the Duplex Motor, the Exit Roller moves the fused print media partially into the output tray where it then reverses in duplex mode and feeds the print media (fused on one side) in the direction of the Registration Chute.

The position of the Chute Assembly Out gears is shown in the following figure.

Note

These gears are spared as part of the Chute Assembly Gear Kit PL5.4.99

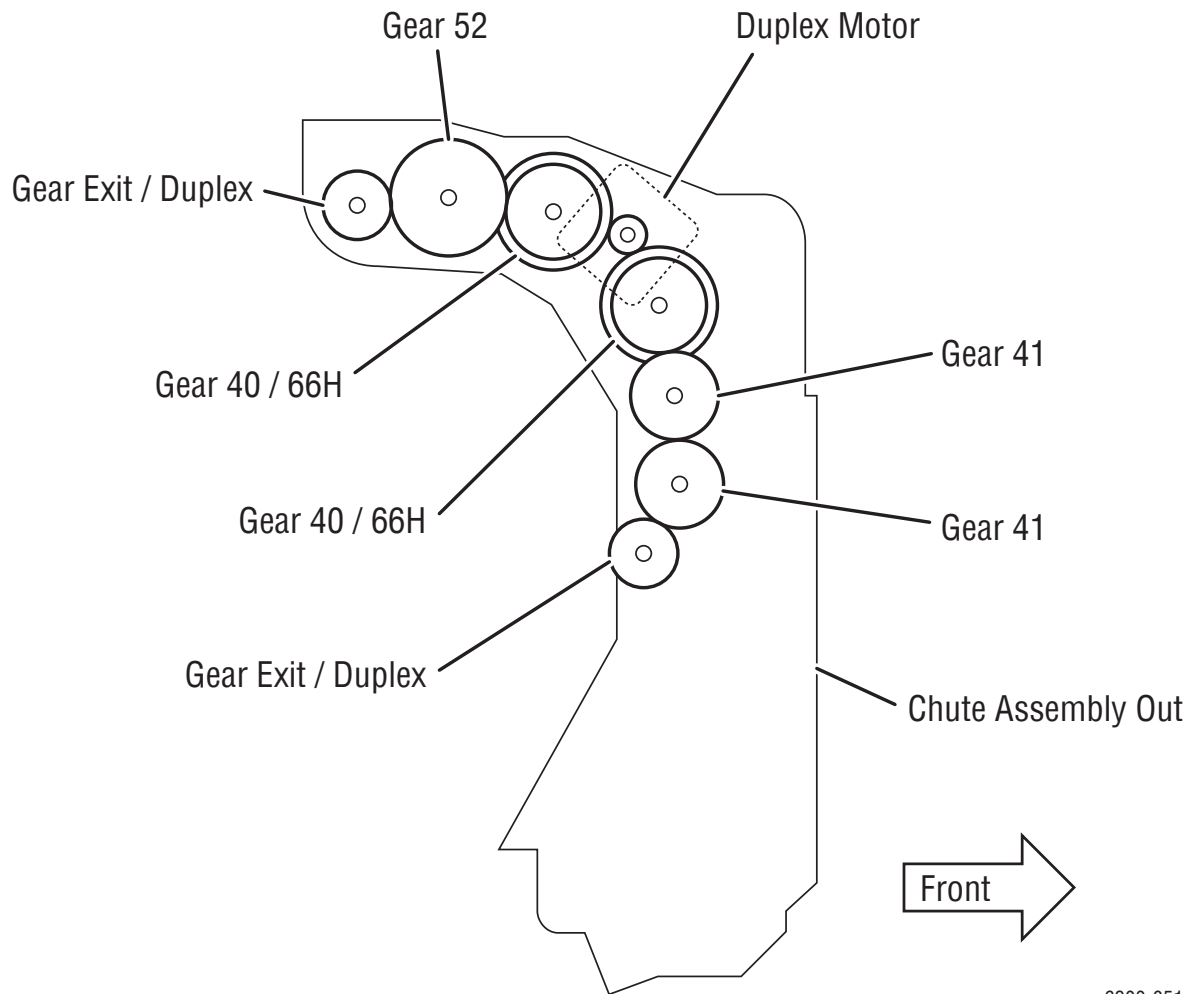

s6300-051

Transfer Roller and Fuser Assembly

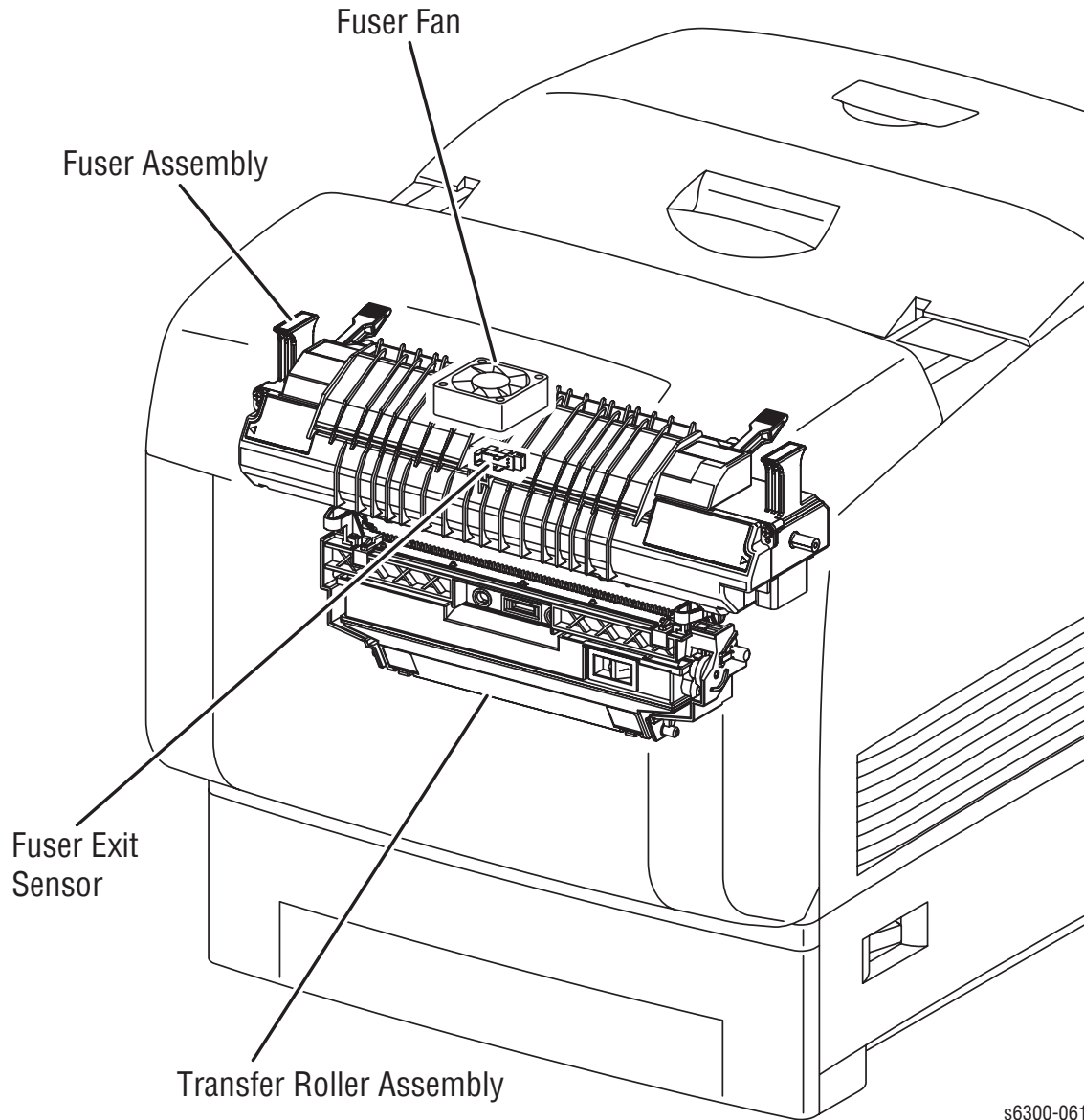

s6300-061

- **Exit Sensor**
Detects passage of the print media after fusing.
- **Transfer Roller**
Consists of the Transfer Roller and a waste toner recovery system. The Transfer Roller transfers the image from IDT2 in the Imaging Unit onto the print media.
- **Fuser Fan**
Cools the Fuser Assembly to prevent overheating.
- **Fuser**
Using heat and pressure, the Fuser fixes the transferred toner onto print media.

Fuser Assembly Components

| Component | Function |
|--------------------|---|
| Heat Roller | The Heat Roller is a metal tube with a coated surface and a Heater Assembly inside. As paper passes between the Heat Roller and Pressure Roller, the heat fuses the toner to the paper. |
| Belt | The Belt maintains pressure on the paper passing between it and the Heat Roller. Pressure bonds the melted toner to the paper. |
| Heater Lamps | The Heater Rods are glass tubes containing heater coils. The Main Heater Rod heats the entire length of the Heat Roller, and the Dual Sub-Heater Rods heat the center. |
| Fuser Exit Roller | Transports media out of the Fuser. |
| Non-Contact Sensor | This sensor detects the center temperature of the Heat Roller. |
| Thermistors | These sensors monitor the Heat Roller outside edge temperature. |
| Thermostat | The Thermostat provides a second-level of protection. If the Heat Roller temperature exceeds the preset temperature, the Thermostat cuts off the AC power to the Heater Lamps. |
| CRUM | Maintains Fuser usage information. |
| Fuser Exit Sensor | This sensor detects paper at the exit area behind the Fuser. When paper is present, the signal /EXIT is Low. |

The following figure shows how the Heat Roller and belt compress the paper and applied toner to fuse the image to the media.

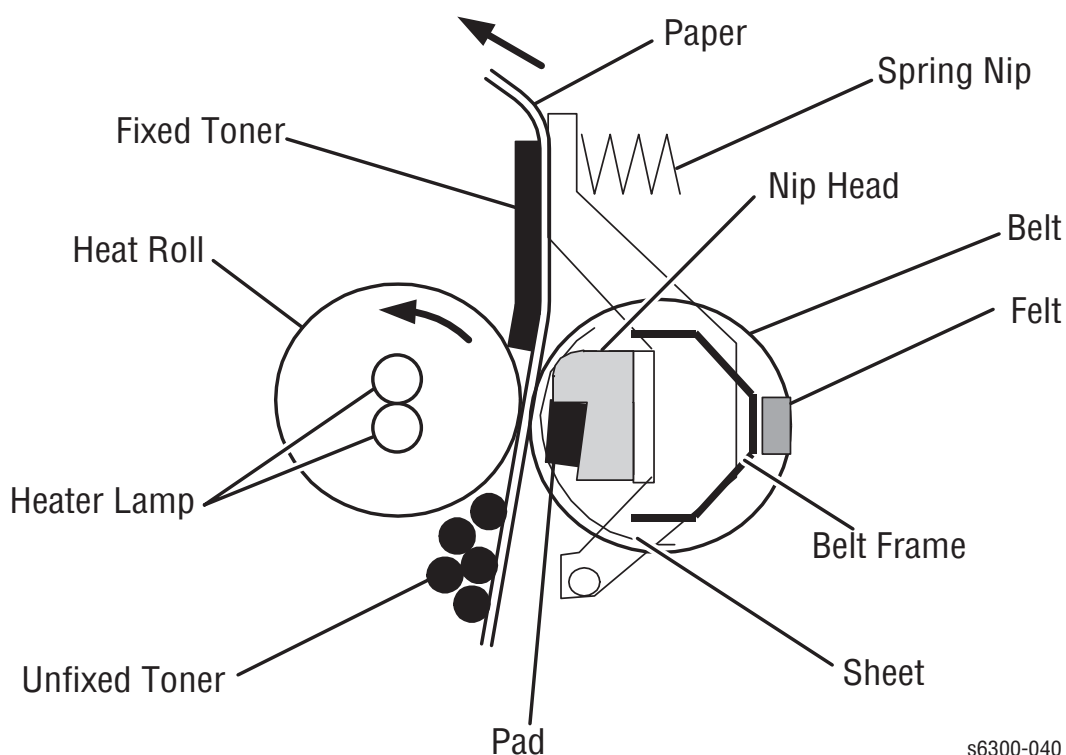

s6300-040

Tray 1 (MPT)

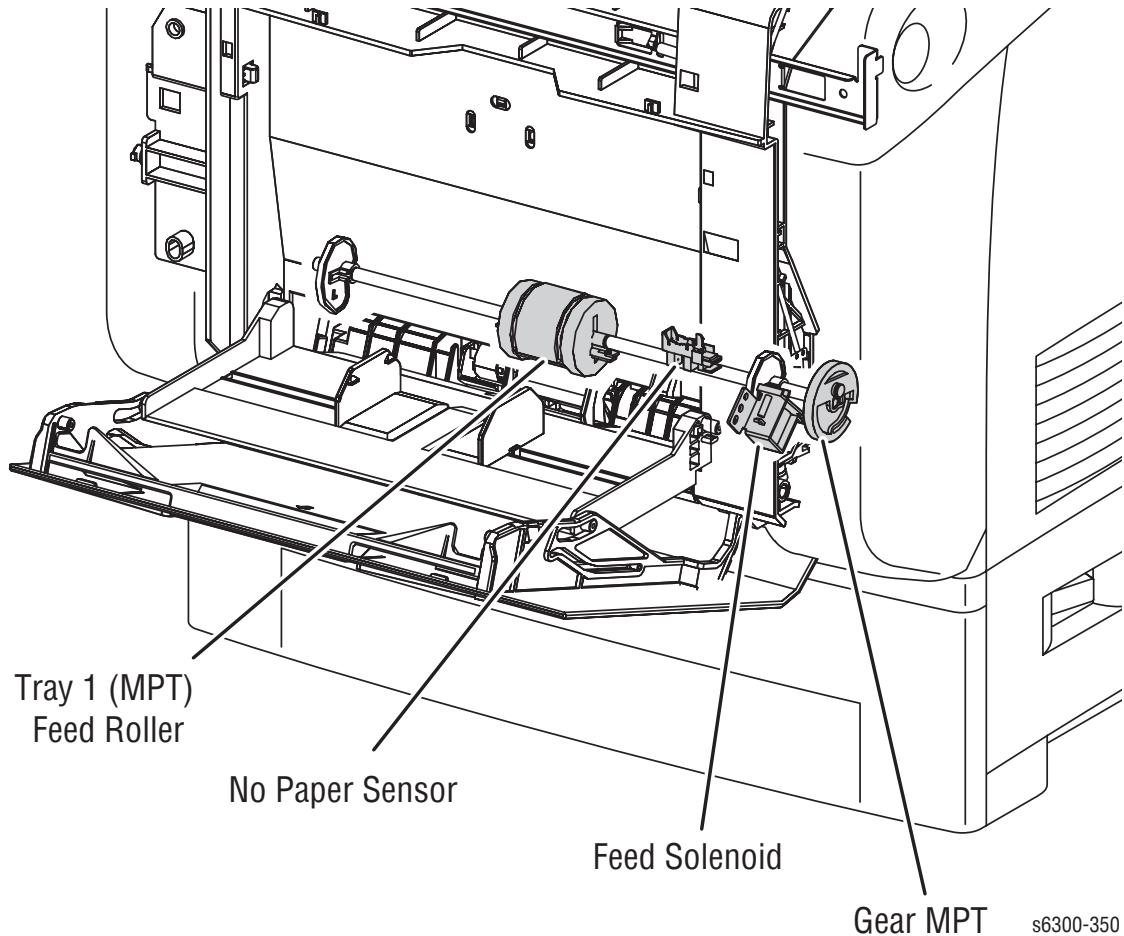

- **Feed Roller**
When the Tray 1 (MPT) Feed Solenoid energizes, the Gear MPT and the Idler Gear are engaged by the force of the solenoid spring. The Feed Roller rotates from the drive of the Main Drive Assembly and feeds paper from Tray 1. After rotating one turn, the Gear MPT and the Idler Gear are disengaged, the Main Drive Assembly and Feed Roller stop, allowing only one sheet of paper to be fed through at a time.
- **Tray 1 (MPT) No Paper Sensor**
Detects whether print media is present.
- **Tray 1 (MPT) Feed Solenoid**
Controls the operation (rotation/stop) of the Tray 1 (MPT) Feed Roller.
- **Size Guides**
Indicates the paper width, maximum capacity, and holds the paper in proper alignment for feeding.

Tray 2

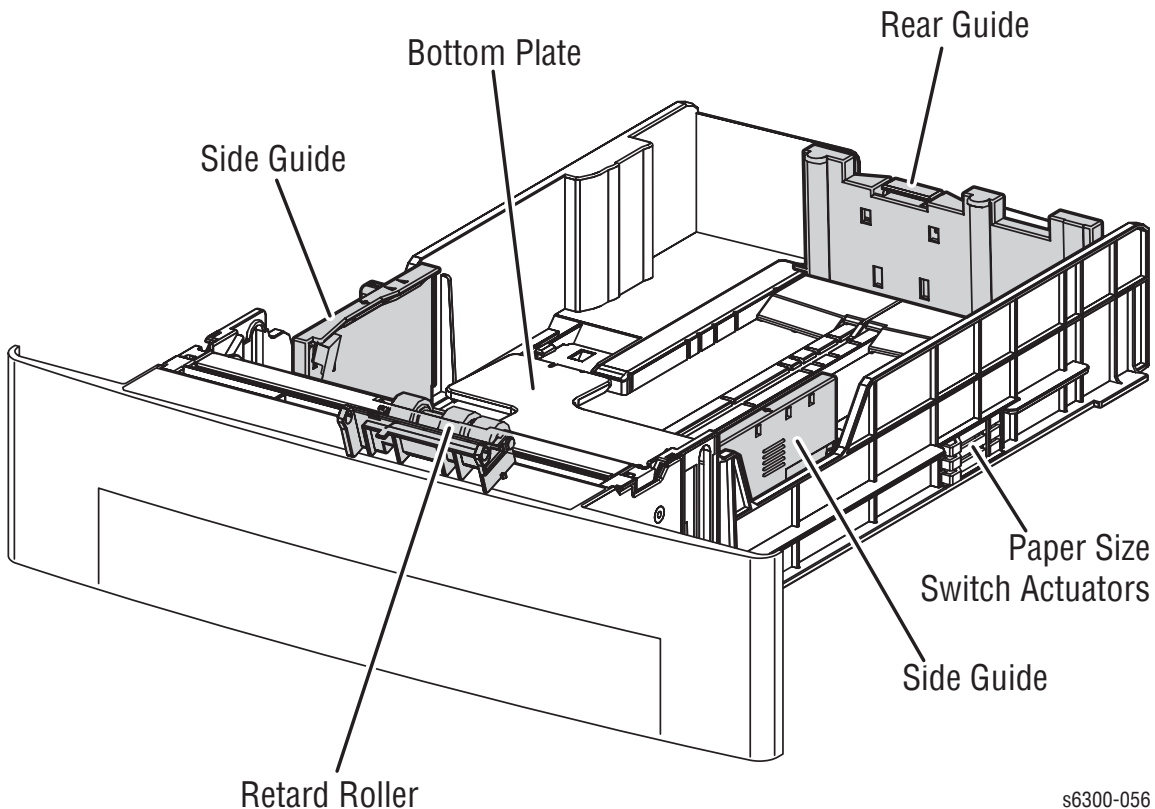

s6300-056

- **Retard Roller**
The Retard Roller limits paper pickup 1 sheet at a time. The Retard Roller and the Nudge Roller are interchangeable parts in all universal trays.
- **Side Guides Right and Left**
The side guides move against media to align or register the width of print media in the paper feed direction.
- **Rear Guide**
The Rear Guide moves to determine the length of print media in the paper feed direction. The Rear Guide contacts the Paper Size Switch actuators to detect the paper size loaded in the tray.

Tray 2 Paper Pick Assembly

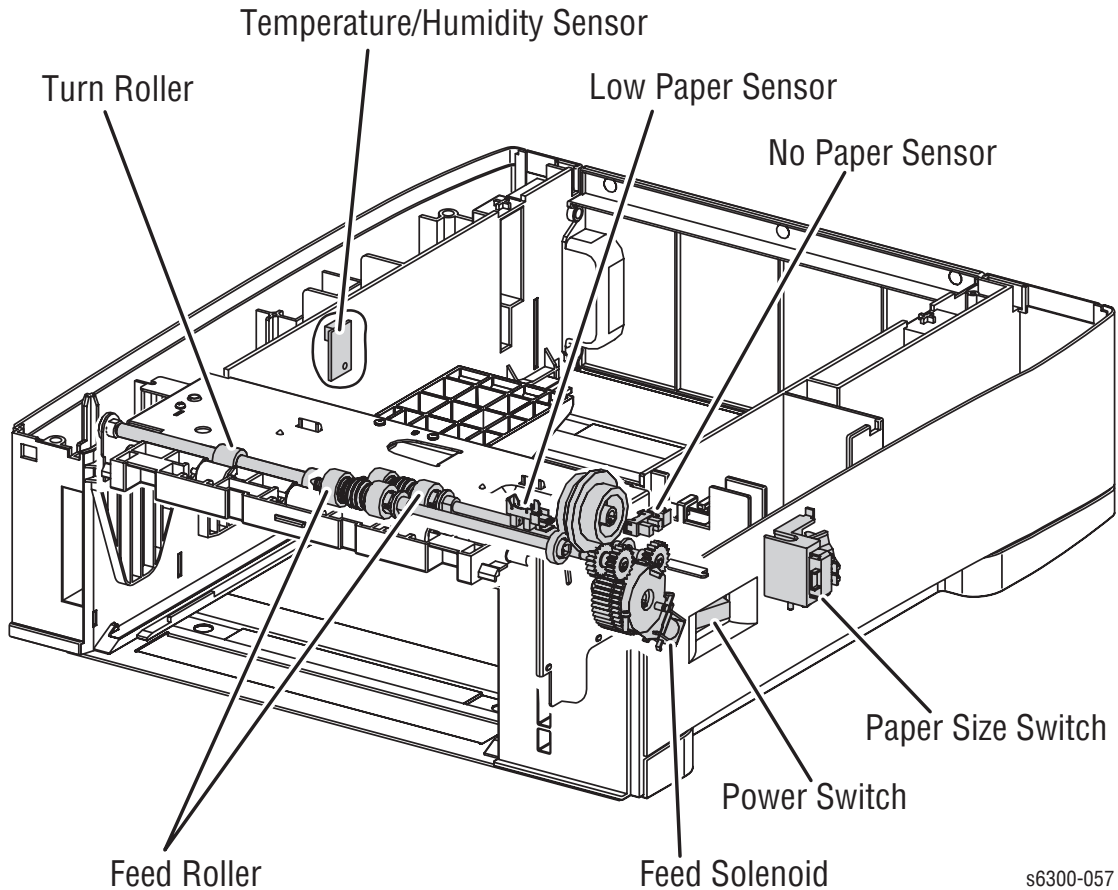

- **Temperature/Humidity Sensor**
Detects temperature and humidity inside the printer to adjust the charge voltage (the voltage supplied to the transfer roller and the developing bias).
- **No Paper Sensor**
Detects presence or absence of print media in the tray based on the position of the Actuator.
- **Feed Rollers**
When the Feed Solenoid energizes, the Spring Feed force engages the Gear Feed and the Gear Idler Feed to turn and feed the paper from the paper tray. This activates the Paper Pick Assembly. After completion of one turn, determined by a cutout in the Gear Feed, the Gear Feed and the Gear Idler Feed are disengaged stopping the paper Retard Feed Roller. This allows one sheet to be fed at a time.
- **Turn Clutch**
Transfers the drive energy from the Main Drive Motor to the Turn Roller.
- **Paper Size Switches**
Detects print media size using the position of the side and rear guides, and presence of the paper tray.

- Gear Feed
See Feed Rollers.
- Spring Feed
See Feed Rollers.
- Gear Idler Feed
See Feed Rollers.
- Feed Solenoid
Controls the operation (rotation/stop) of the Feed Roller Assembly by controlling the rotations of the Gear Feed.
- Low Paper Sensor
The actuator lowers as print media is used in the tray. When the actuator lowers to a pre-determined position, it blocks the sensor beam to trigger a low paper status. The actuator position can be seen from the front of the paper tray allowing confirmation of the print media quantity.
- Turn Roller
The Turn Roller receives drive energy from the Main Drive Motor through the Turn Clutch and transports the print media out of the paper tray to the Registration Roller.

Xerographics

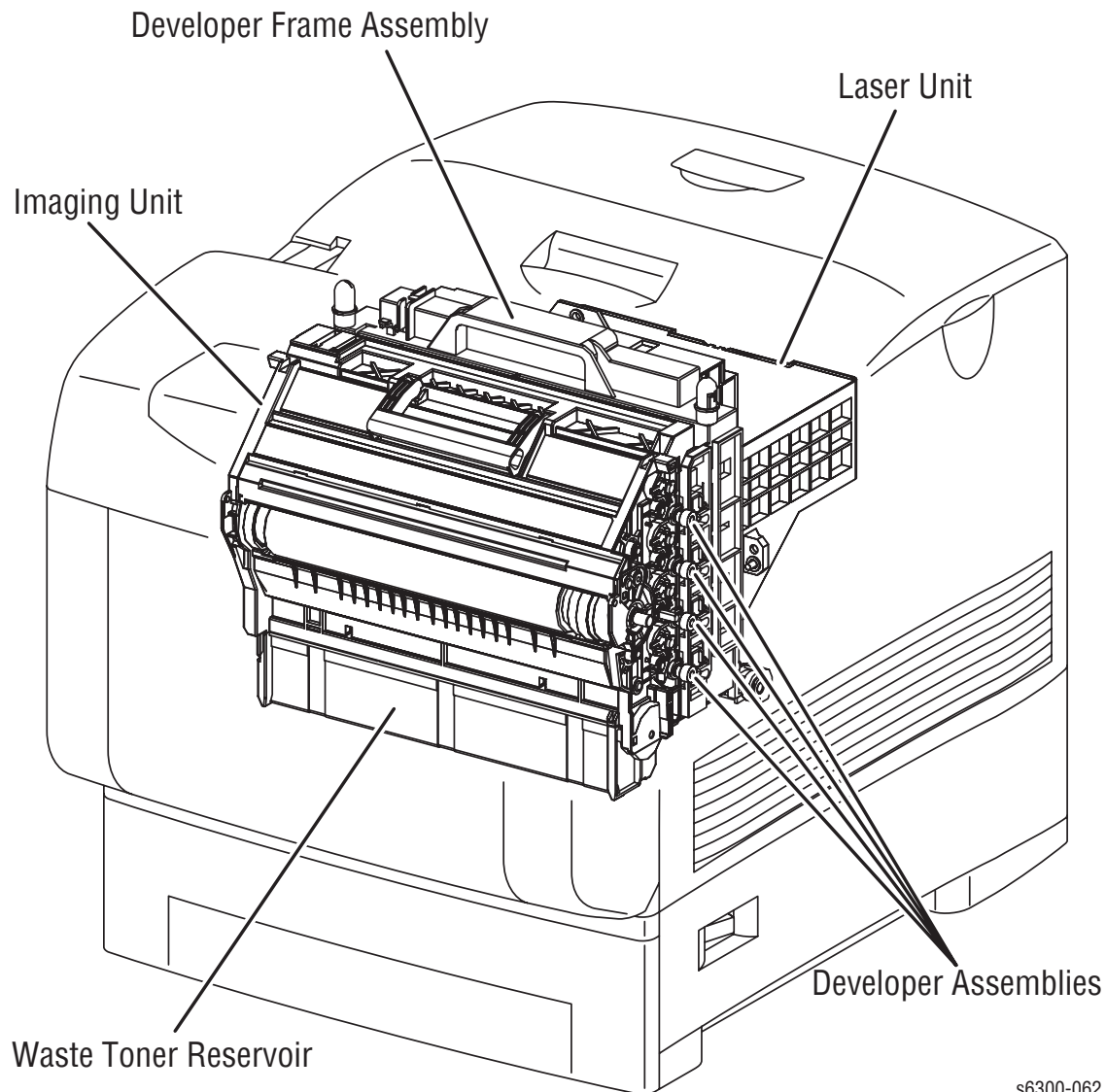

s6300-062

■ Developer Assemblies

The Developer Assemblies receive toner from the Toner Cartridge and through electrostatic attraction, transfer toner to the latent image on each of the four color drums.

■ Imaging Unit

The Imaging Unit carries out the operations of the printing process, such as charging, primary and secondary transfer. The Imaging Unit consists of the following parts:

- | | |
|---------------------------|-------------------------|
| ■ Drum (Y M C K) | ■ Refresher (Y M C K) |
| ■ Charge Roller (Y M C K) | ■ IDT2 |
| ■ IDT1 (2) | ■ IDT2 Cleaner |
| ■ IDT1 Cleaner (2) | ■ Waste Toner Reservoir |

■ Laser Unit

The Laser Unit receives image data from the Engine Control Board and generates laser beams to form an electrostatic latent image on the surface of each of the four imaging unit drums. The Laser Unit consists of the following parts:

- Quad-beam Laser Diode
- SOS Board
- Polygon Mirror
- Scanner Motor
- Lenses
- Window

The components of the Laser Unit appear in the following figure.

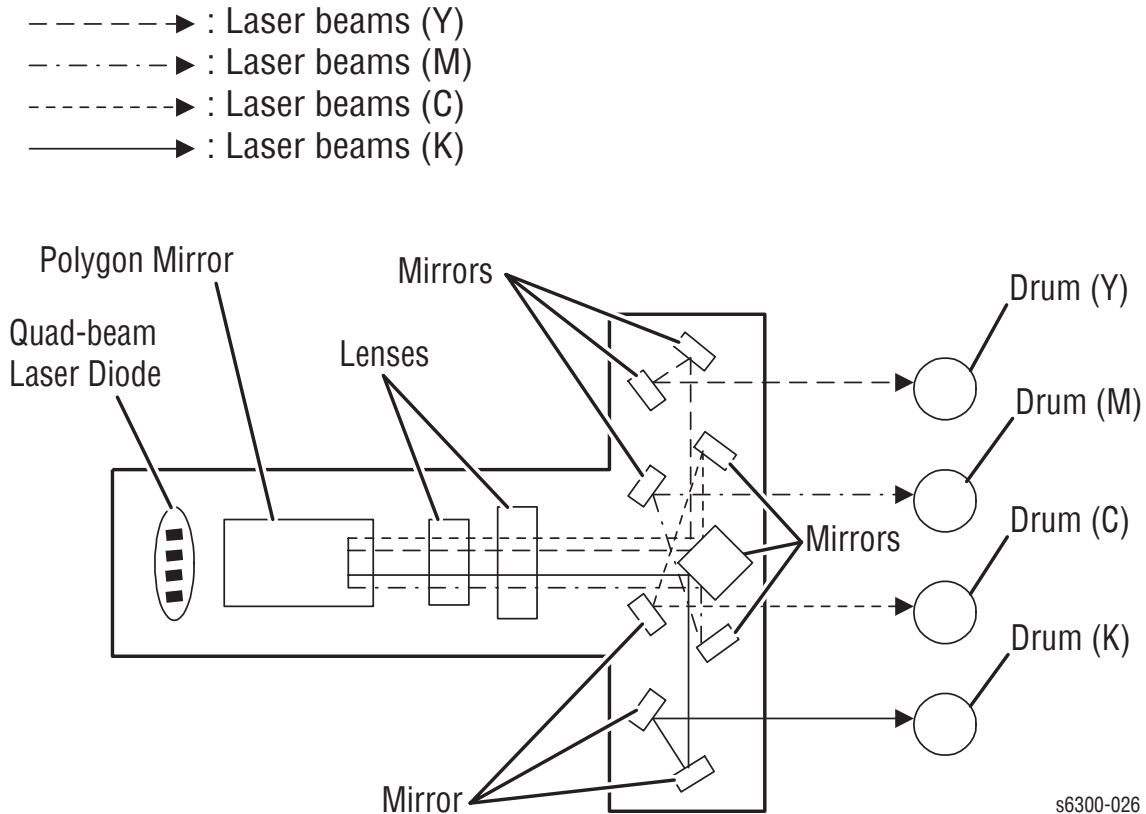

Toner Cartridge Holder Assembly

The Toner Cartridge Holder is responsible for transporting toner from the four Toner Cartridges to the Developer Assemblies. The following figure shows the location of each major component.

Note

When servicing components of the Toner Cartridge Holders, CRUM Reader, and cartridge sensors, avoid disconnecting the Auger Tubes from the Developer Frame Assembly. All repairs, excluding replacement of the holder itself and removal of the Developer Frame Assembly, are possible with the Auger Tubes attached. Once the covers are removed, re-install the Toner Cartridges to help avoid toner spills.

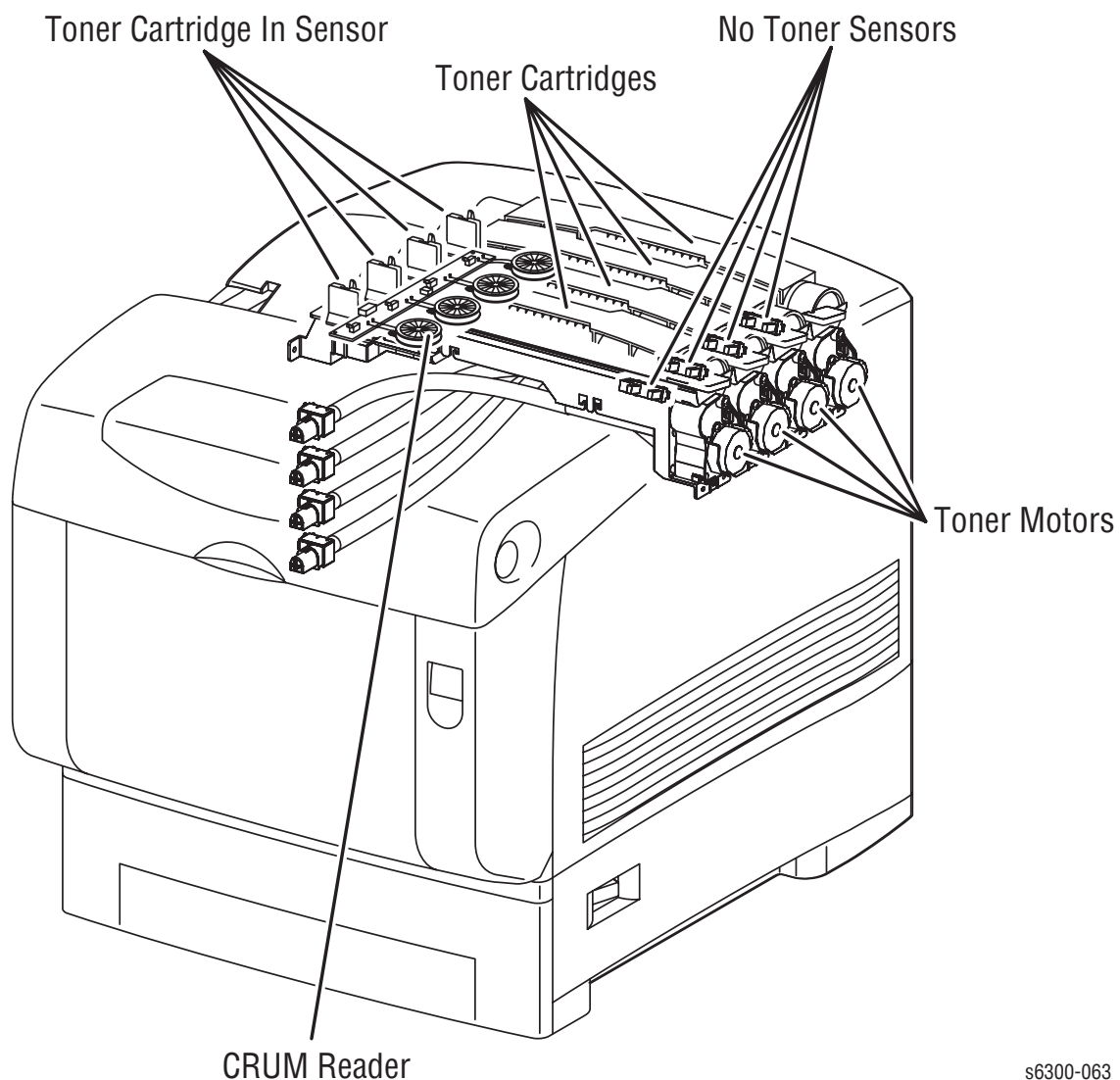

s6300-063

- No Toner Sensors [Y] [M] [C] [K]
Detects level of toner at the mouth of each auger tube.
- Toner Cartridge In Sensors [Y] [M] [C] [K]
Detects the presence of the Toner Cartridge in the holder.
- CRUM Reader
Reads the information contained in the Toner Cartridge CRUM.
- Toner Cartridges [Y] [M] [C] [K]
Individual Toner Cartridges containing a toner mixture.
- Toner Motors [Y] [M] [C] [K]
The Toner Cartridge Holder Assemblies each contain a Toner Motor which drives the Agitator in the Toner Cartridges and the Auger in the Toner Cartridge Holder, supplying toner through the Auger Tube to the Developer Assembly.

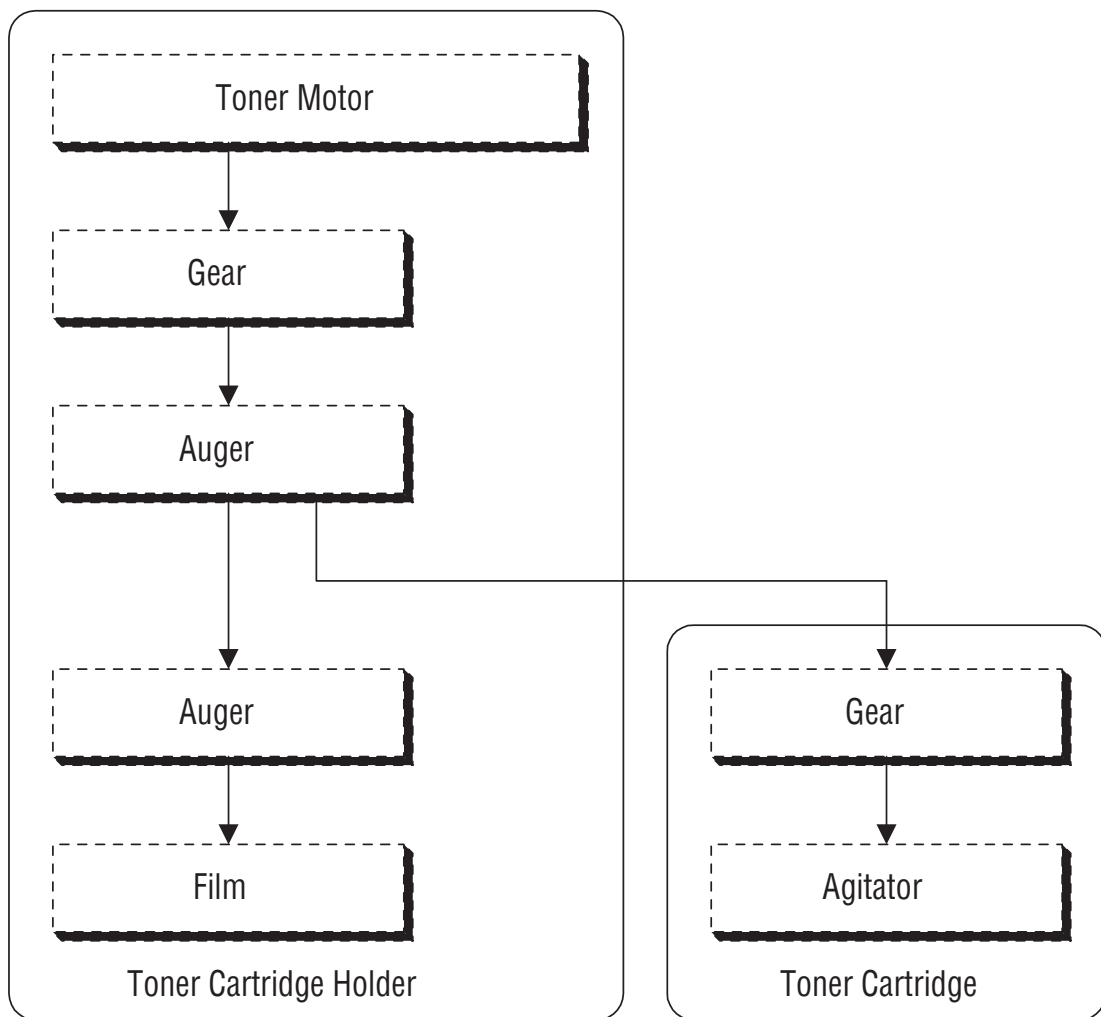

s6300-046

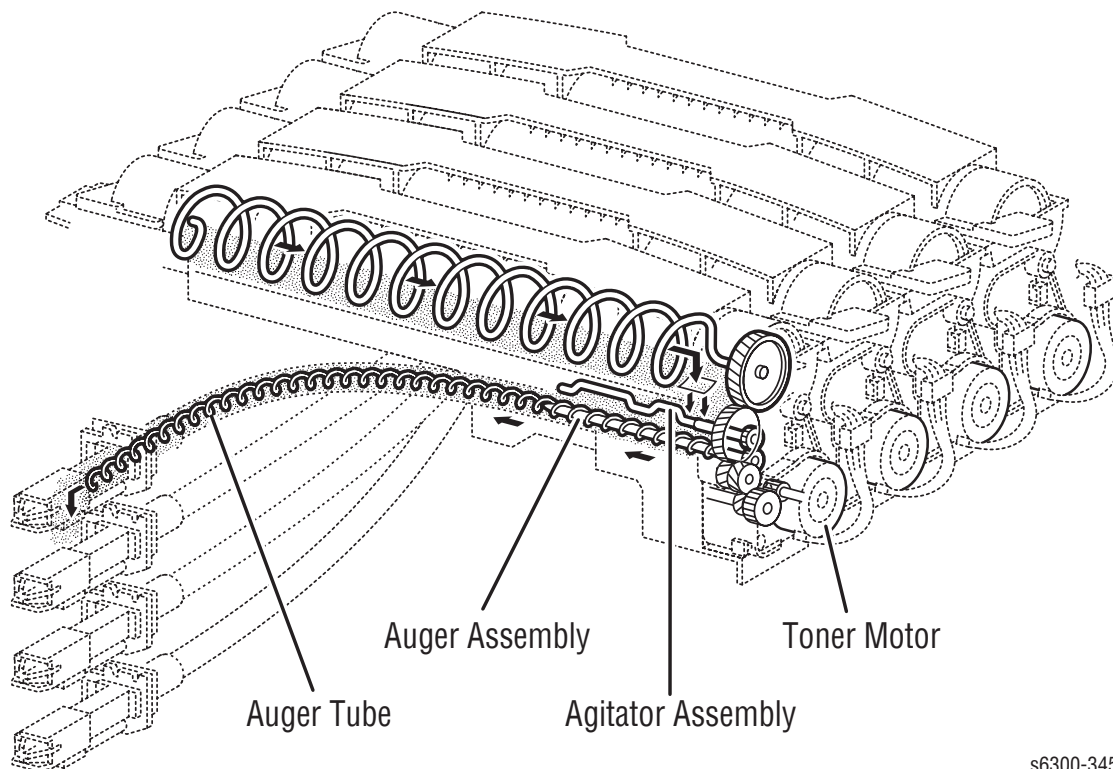

s6300-345

Electrical

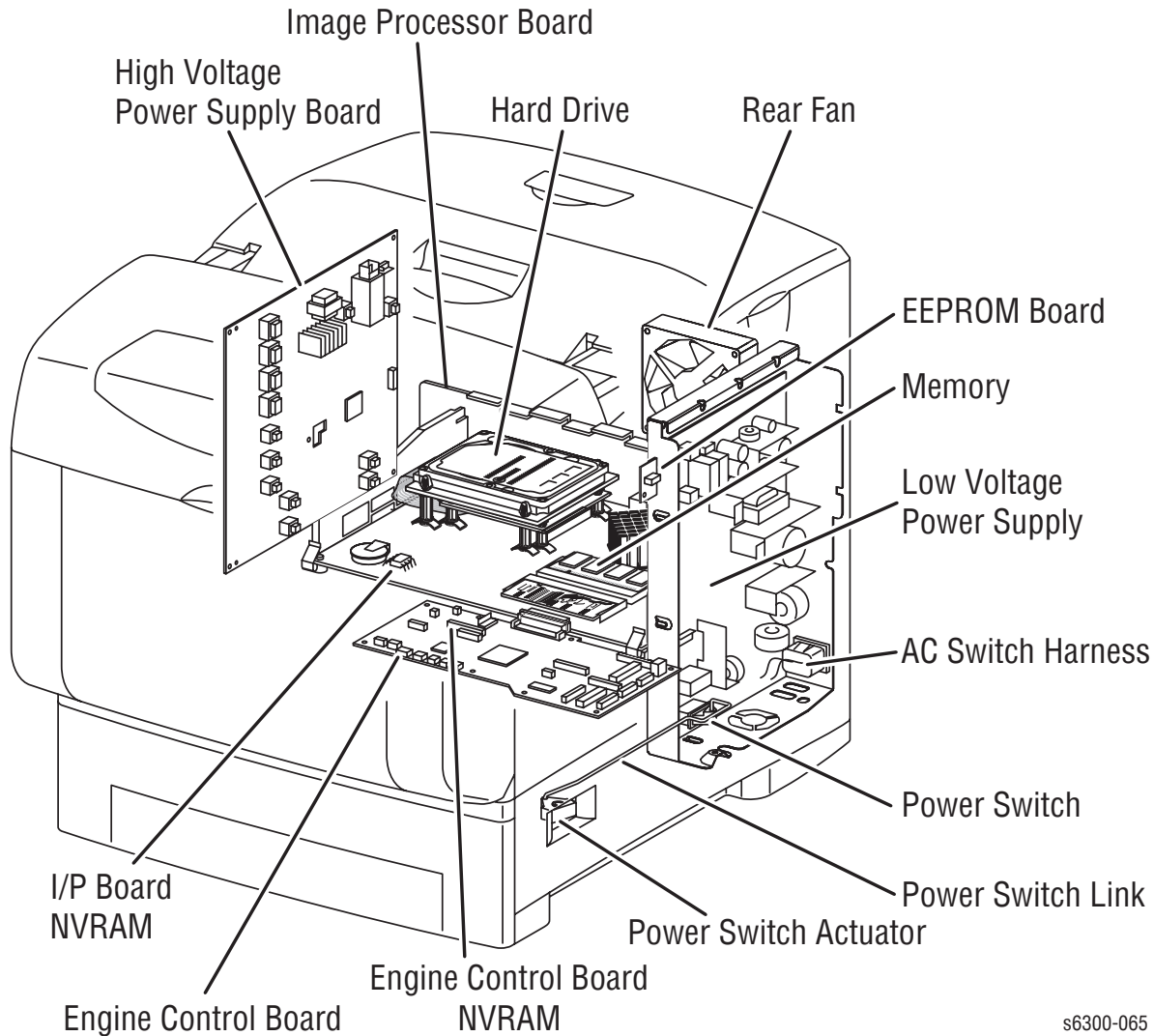

- **Image Processor Board**
Receives data from the workstation or host, rasterizes the data and passes it on to the Engine Control Board. The microprocessors on the Image Processor Board, generate the control signals used by the Engine Control Board. Also located on the Image Processor Board are the system NVRAM chip, optional Memory, and optional Hard Drive.
- **EEPROM Board**
Consumable use (Fuser and Imaging Unit NVRAM data) information is stored and communicated to the Engine Control Board.
- **Rear Fan**
Removes heat from the printer to prevent over-heating.

- **Power Switch**
An actuator and linkage is used to activate the Power Switch located on the Low-Voltage Power Supply.
- **High-Voltage Power Supply Board (HVPS)**
Supplies high-voltage to the Transfer Roller and Imaging Unit.
- **Low-Voltage Power Supply Board (LVPS)**
Supplies AC power from the power source to the Fuser heater. Generates and supplies stable low-voltage DC power (+3.3 VDC, +5 VDC, and +24 VDC) to be used for the logic and other circuits within the printer. The LVPS includes the LVPS Board with attached Power Switch, the AC Harness, and the box enclosure.
- **Engine Control Board**
Controls printing operation based on the communication with the Image Processor Board and input from the sensors and switches.

Major Functions:

- Communicates with the Image Processor Board
- Receives information from the sensors and/or switches.
- Generates the video for the laser based on information from the Image Processor Board.
- Controls high-voltage sent to the Imaging Unit to perform charging, development, primary and secondary transfer.
- Distributes the low-voltage DC power from the Low-Voltage Power Supply.
- Controls the motor in the Main Drive Assembly, Developer Drive Assembly, Fuser Drive Assembly, Duplex Motor Assembly and the Toner Cartridge Holder.

1100-Sheet Feeder Assemblies

The 1100-Sheet Feeder forms a base for the printer and adds two, 550-sheet, universal trays. Control signals reach the sheet feeder by a single connection. The sheet feeder is secured to the print engine with four screws located under Tray 2.

Major functional components of the optional 1100-Sheet Feeder are described below.

- **No Paper Sensor**
Detects presence or absence of print media in the tray based on the position of the Actuator.
- **Feed Rollers**
When the Feed Solenoid energizes, the Spring Feed force engages the Gear Feed and the Gear Idler Feed to turn and feed the paper from the paper tray. This activates the Paper Pick Assembly. After completion of one turn, determined by a cutout in the Gear Feed, the Gear Feed and the Gear Idler Feed are disengaged stopping the paper Retard Roller. This allows one sheet to be fed at a time.
- **Turn Clutch**
Transfers the drive energy from the main drive assembly to the roll turn assembly.
- **Paper Size Switch**
Detects print media size and installation of the paper tray.
- **Feed Solenoid**
Controls the operation (rotation/stop) of the Feed Roller Assembly by controlling the rotations of the Gear Feed.
- **Turn Roller**
The Turn Roller receives drive energy from the Drive Assembly through the Turn Clutch and transports the print media out of the paper tray to the printer's Registration Rollers.

Paper Pick Assemblies

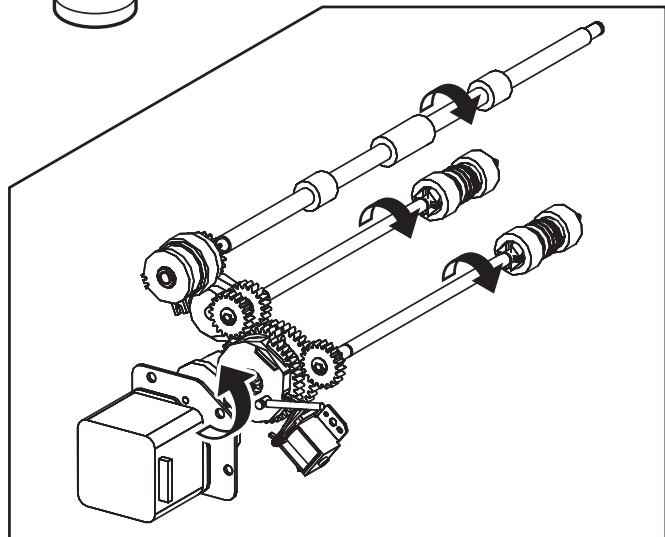
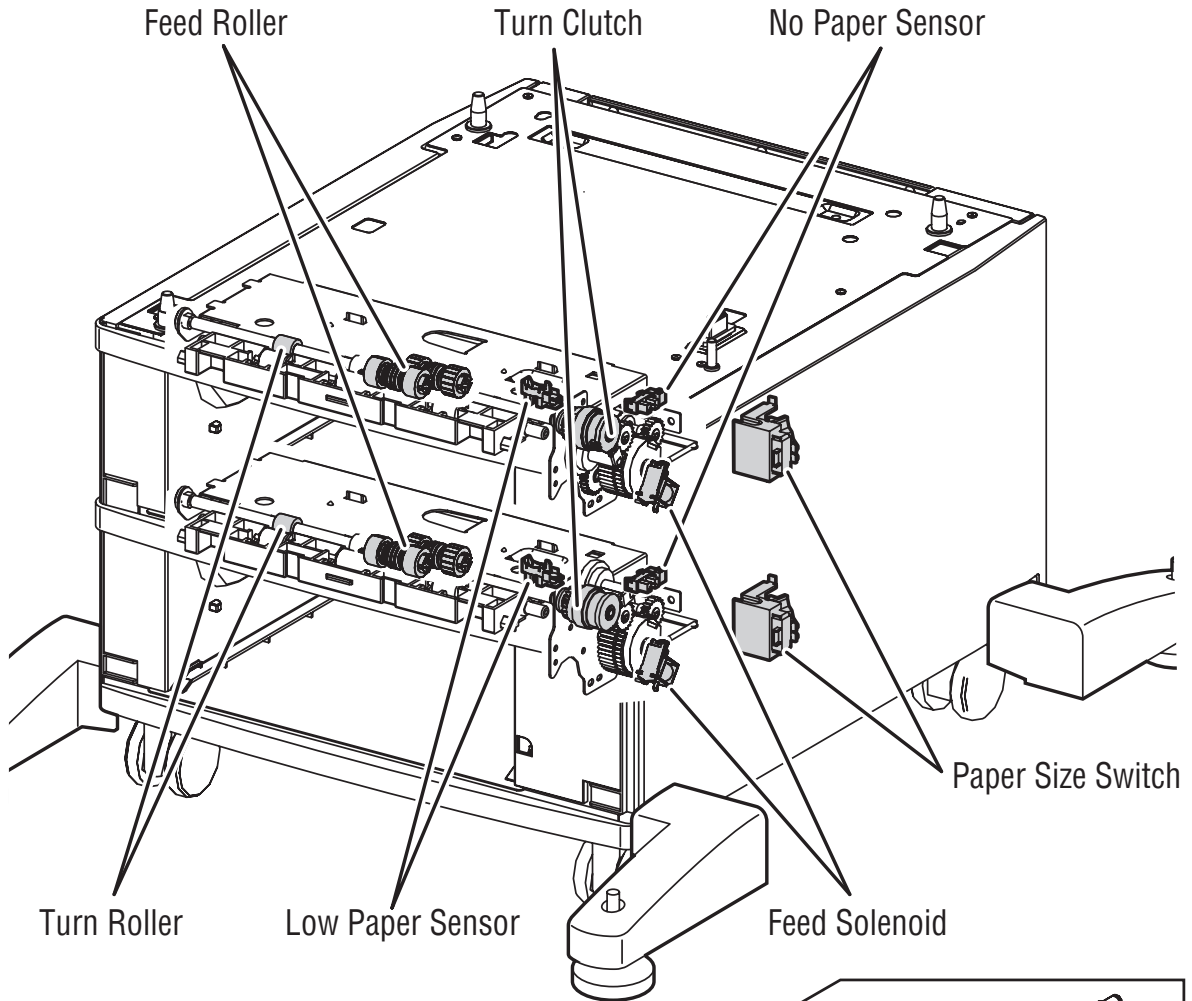

s6300-079

Electrical

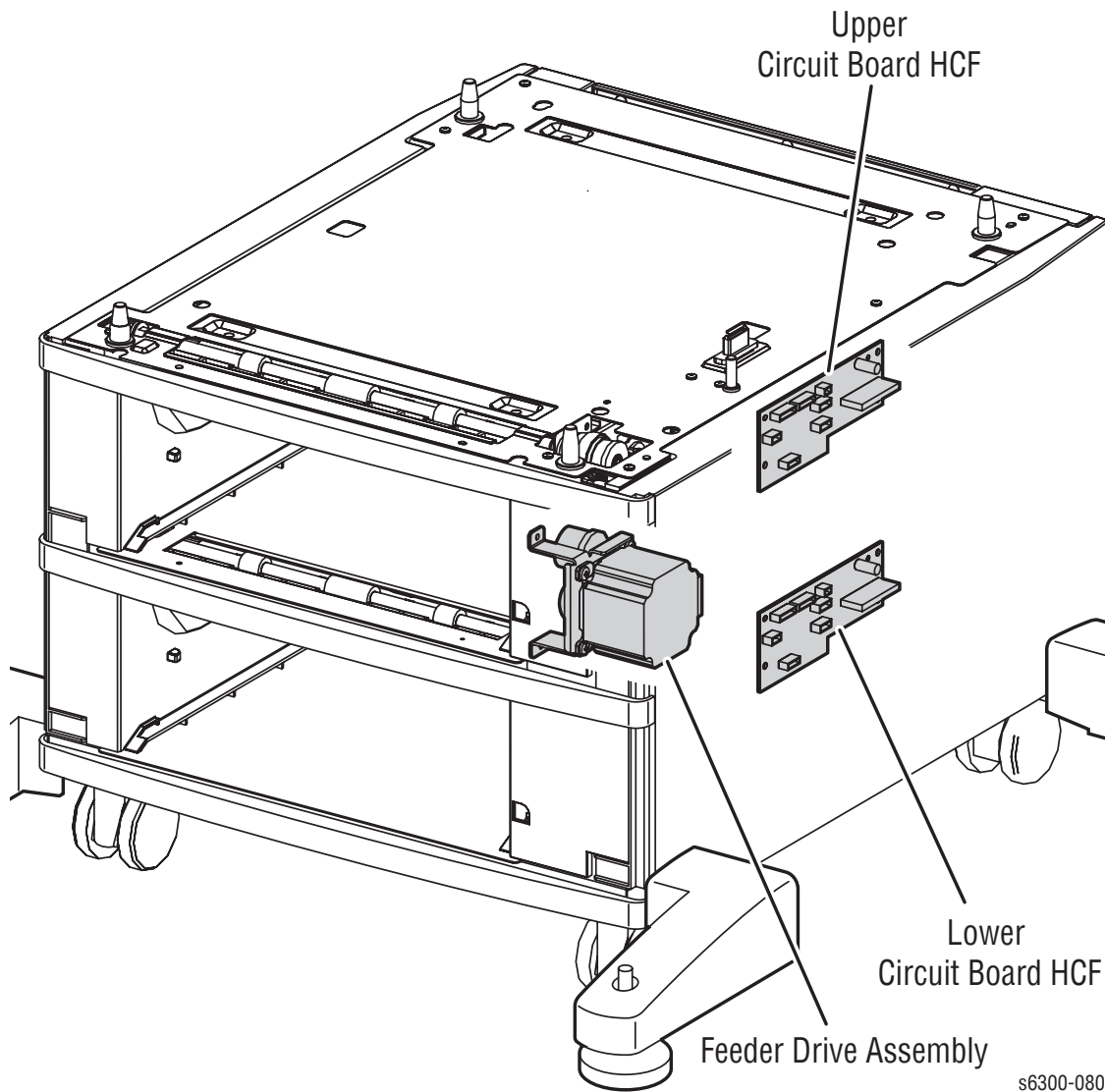

- **Circuit Board HCF (OPTFDR 2)**
Controls the paper pickup operation of each tray based on communication with the Engine Control Board and information from the sensors and switches.

Major Functions:

- Communicates with the Engine Control Board.
- Receives information transmitted from the sensors and switches.
- Controls the Feeder Drive Assembly.
- Controls the paper pick process.
- Distributes the DC voltage from the printer's LVPS to each component.
- **Drive Assembly**
Drives the Pickup Assemblies.
- **Low Paper Sensors**
The actuator lowers as print media is used in the tray. When the actuator blocks the sensor, low paper status is indicated.

Drive

The Drive Assembly incorporates a stepper motor to power the gear train as shown in the following figure.

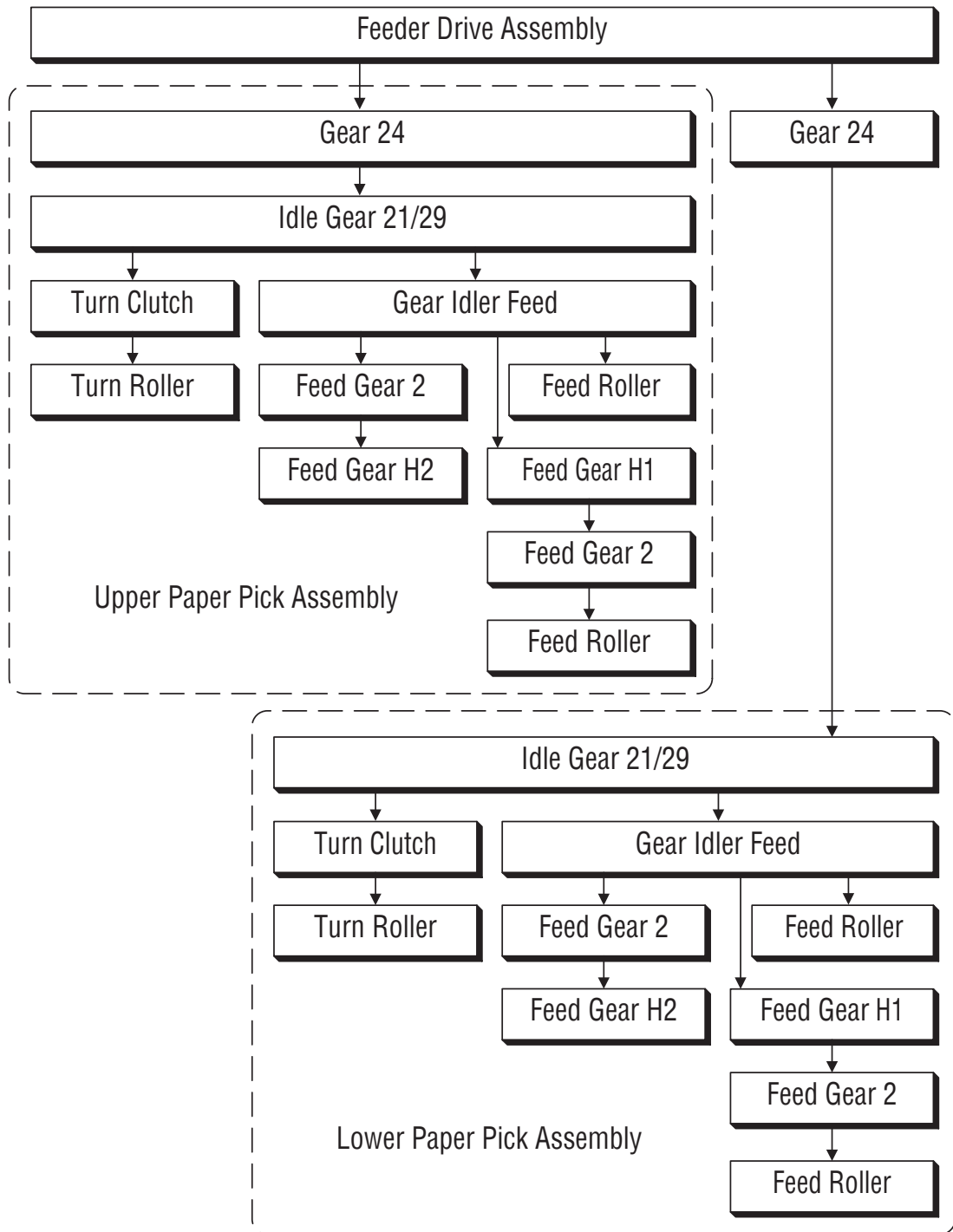

s6300-075

Drive Gears

The gears involved in feeding print media into the printer are identified in the following figure.

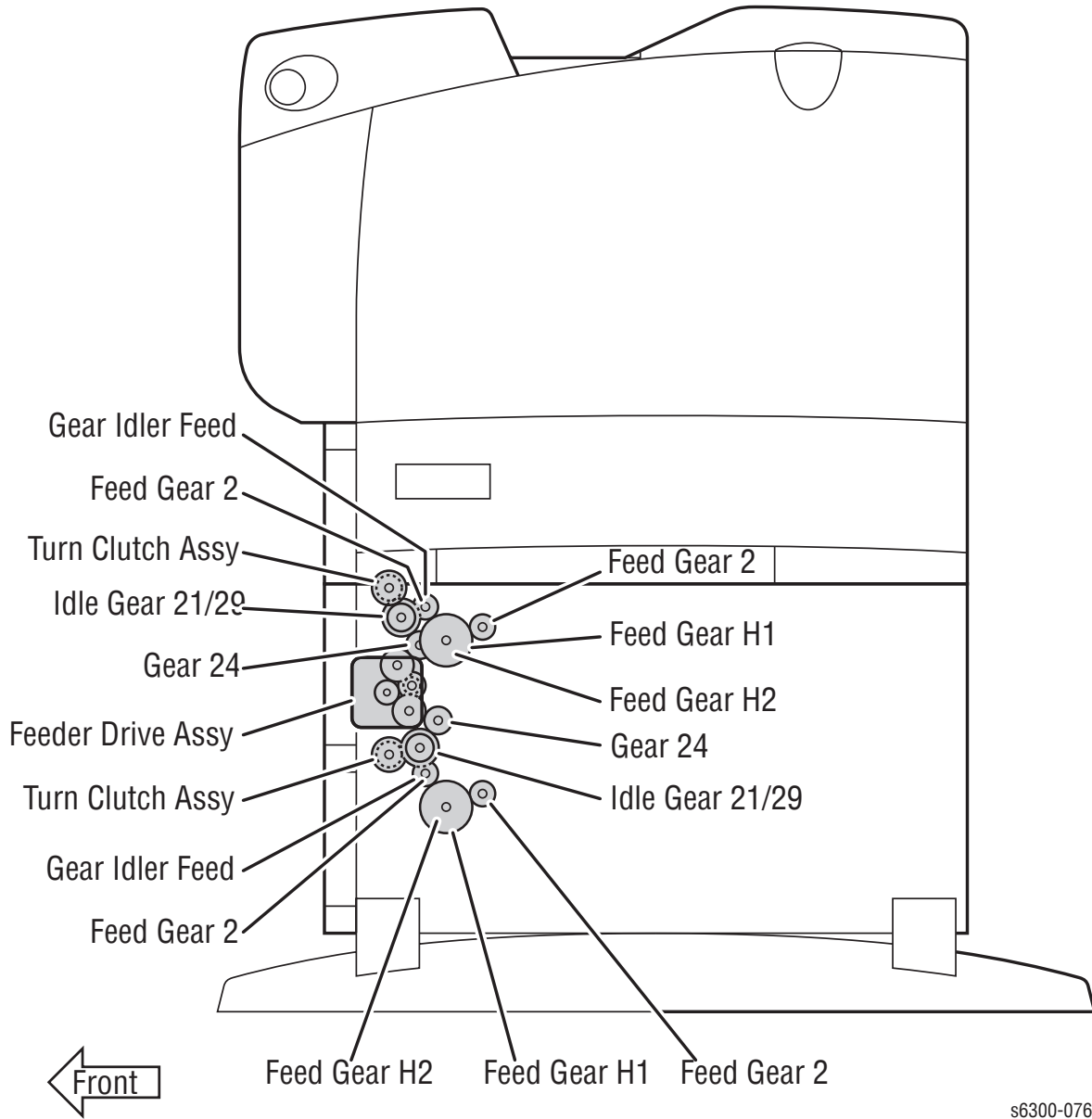

s6300-076

550-Sheet Feeder Assemblies

The 550-Sheet Feeder forms a base for the printer and adds a 550-sheet, universal tray. Control signals reach the sheet feeder by a single connection. The sheet feeder is secured to the print engine with four screws located under Tray 2.

Major functional components of the optional 1100-Sheet Feeder are described below.

- **No Paper Sensor**
Detects presence or absence of print media in the tray based on the position of the Actuator.
- **Feed Rollers**
When the Feed Solenoid energizes, the Spring Feed force engages the Gear Feed and the Gear Idler Feed to turn and feed the paper from the paper tray. This activates the Paper Pick Assembly. After completion of one turn, determined by a cutout in the Gear Feed, the Gear Feed and the Gear Idler Feed are disengaged stopping the paper Retard Roller. This allows one sheet to be fed at a time.
- **Turn Clutch**
Transfers the drive energy from the main drive assembly to the roll turn assembly.
- **Paper Size Switch**
Detects print media size and installation of the paper tray.
- **Feed Solenoid**
Controls the operation (rotation/stop) of the Feed Roller Assembly by controlling the rotations of the Gear Feed.
- **Turn Roller**
The Turn Roller receives drive energy from the Drive Assembly through the Turn Clutch and transports the print media out of the paper tray to the printer's Registration Rollers.

Note

The Phaser 6300/6350 printer supports the installation of only one 550-Sheet Feeder. However, an 1100-Sheet Feeder is available to increase the tray count to the maximum of five.

Tray 3 Feeder

Note

The Tray 2 Paper Pick Assembly has a different part number than the 550-Sheet Feeder's Paper Pick Assembly.

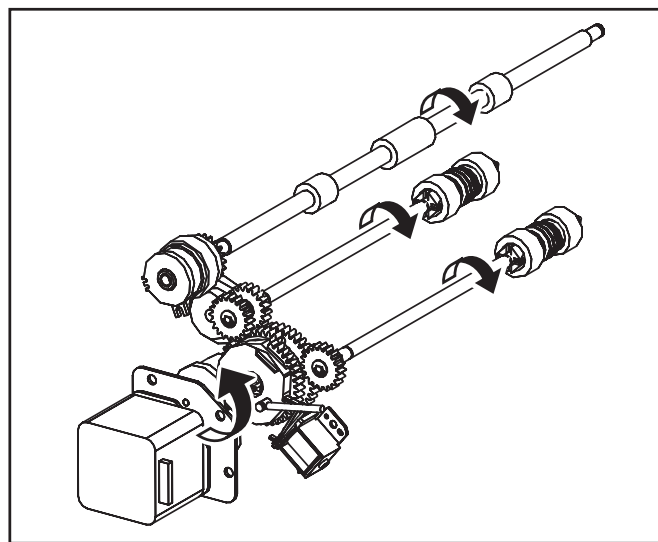
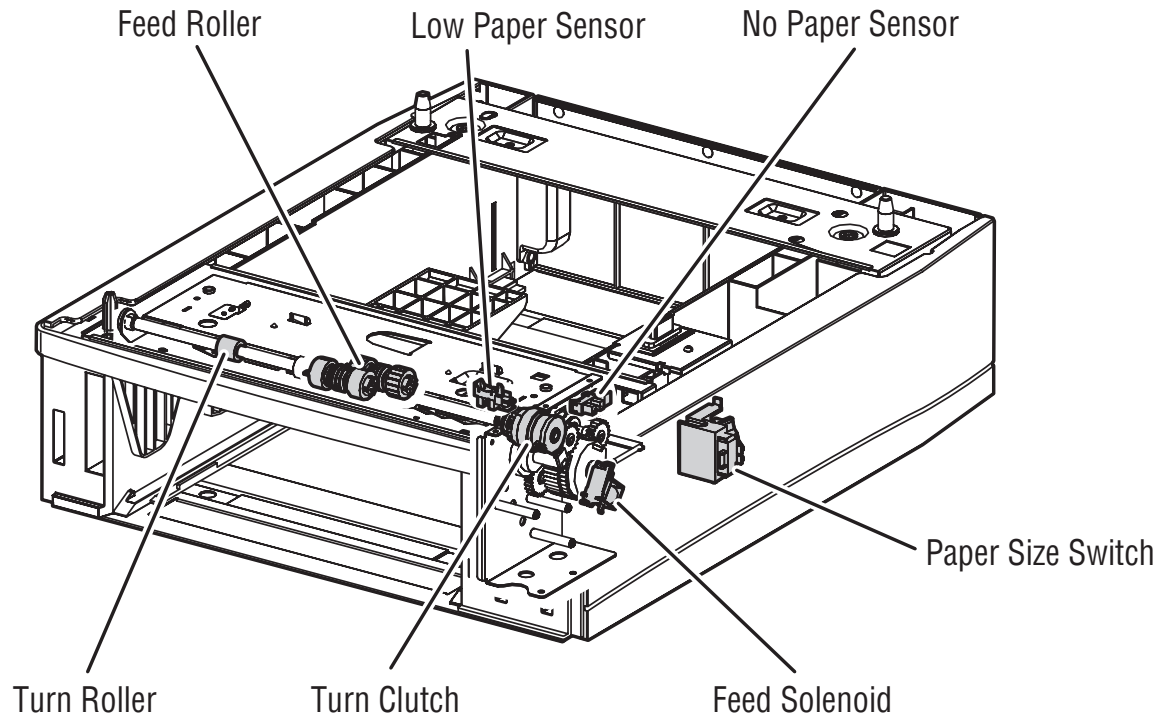

s6300-073

Electrical

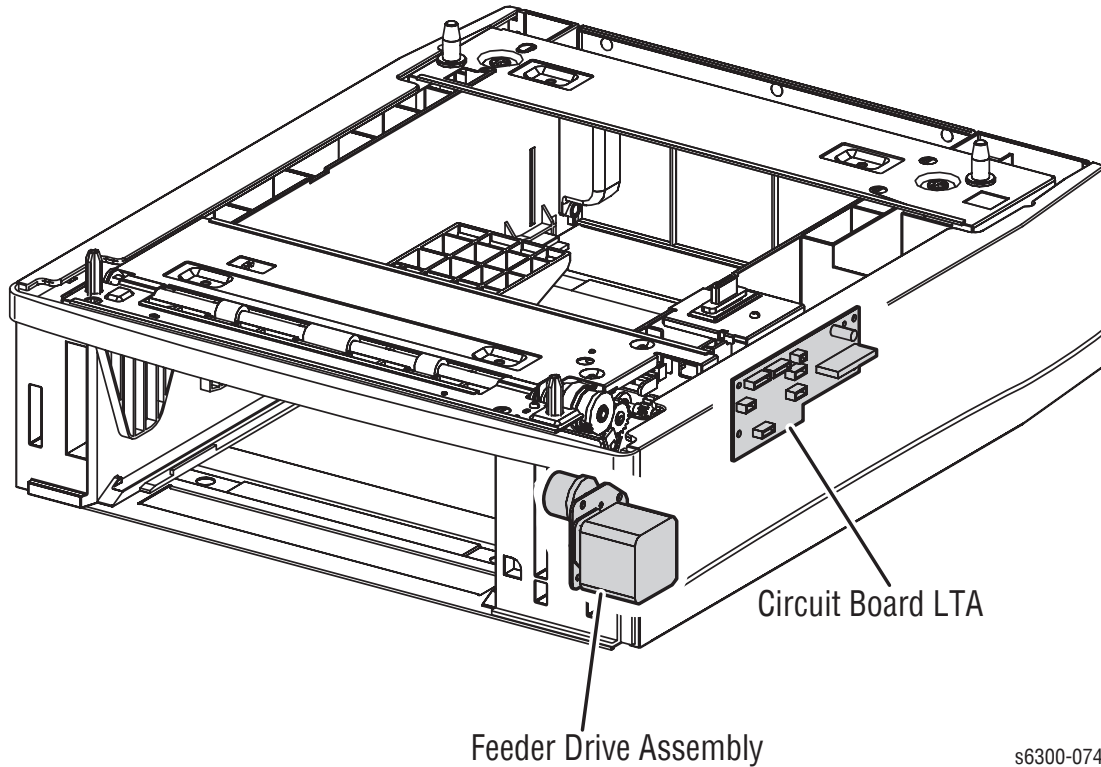

s6300-074

- **Circuit Board LTA (OPTFDR 1)**
Controls the paper pickup operation based on communication with the Engine Control Board and information from the sensors and switches.

Major Functions:

- Communicates with the Engine Control Board.
- Receives information transmitted from the sensors and switches.
- Controls the Feeder Drive Assembly.
- Controls the paper pick process.
- Distributes the DC voltage from the printer's LVPS to each component.
- **Drive Assembly**
Drives the Paper Pick Assembly.
- **Low Paper Sensors**
The actuator lowers as print media is used in the tray. When the actuator blocks the sensor, low paper status is indicated.

Drive

The Drive Assembly incorporates a stepper motor to power the gear train as shown in the following figure.

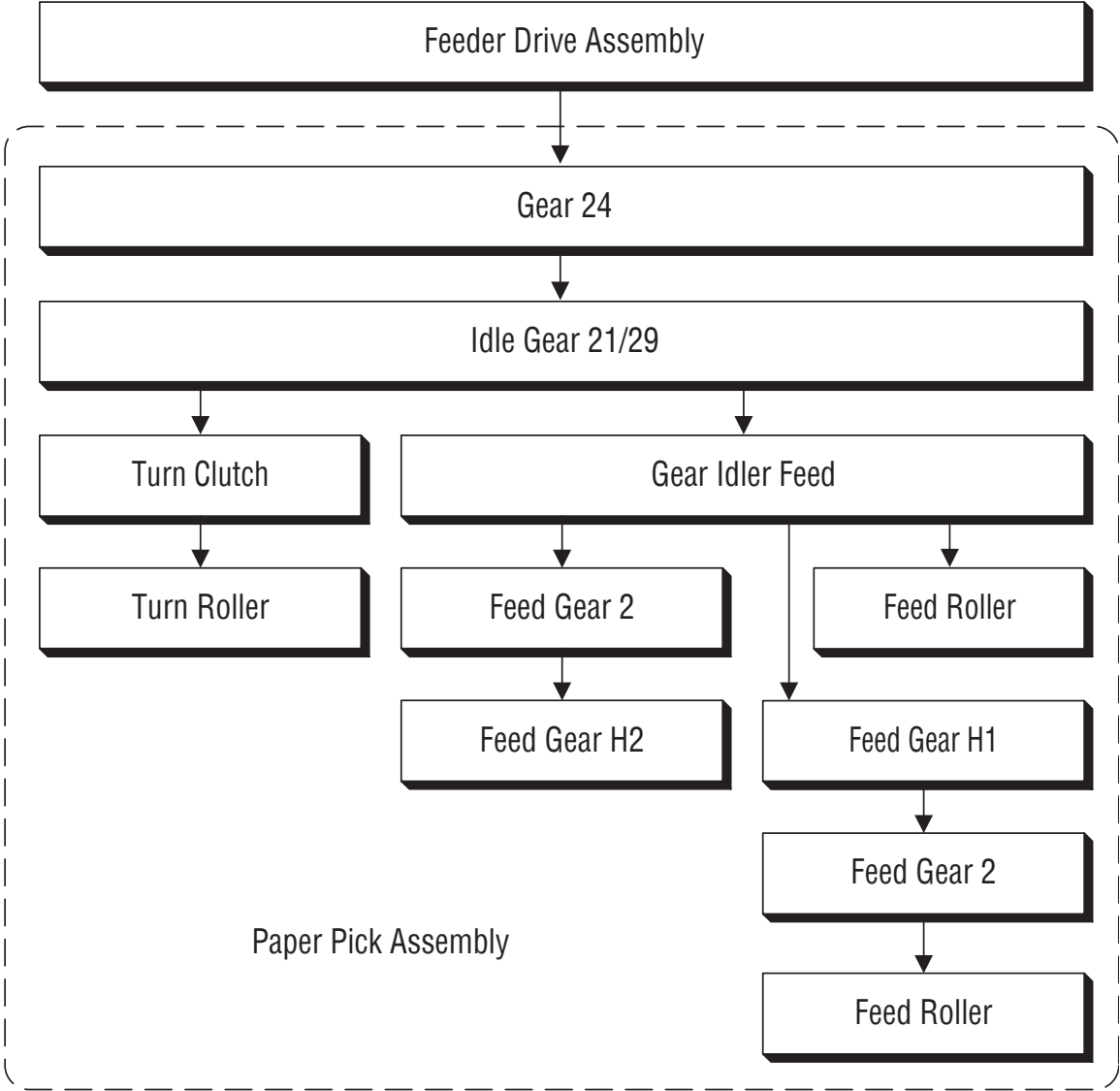

s6300-069

Drive Gears

The gears involved in feeding print media into the printer are identified in the following figure.

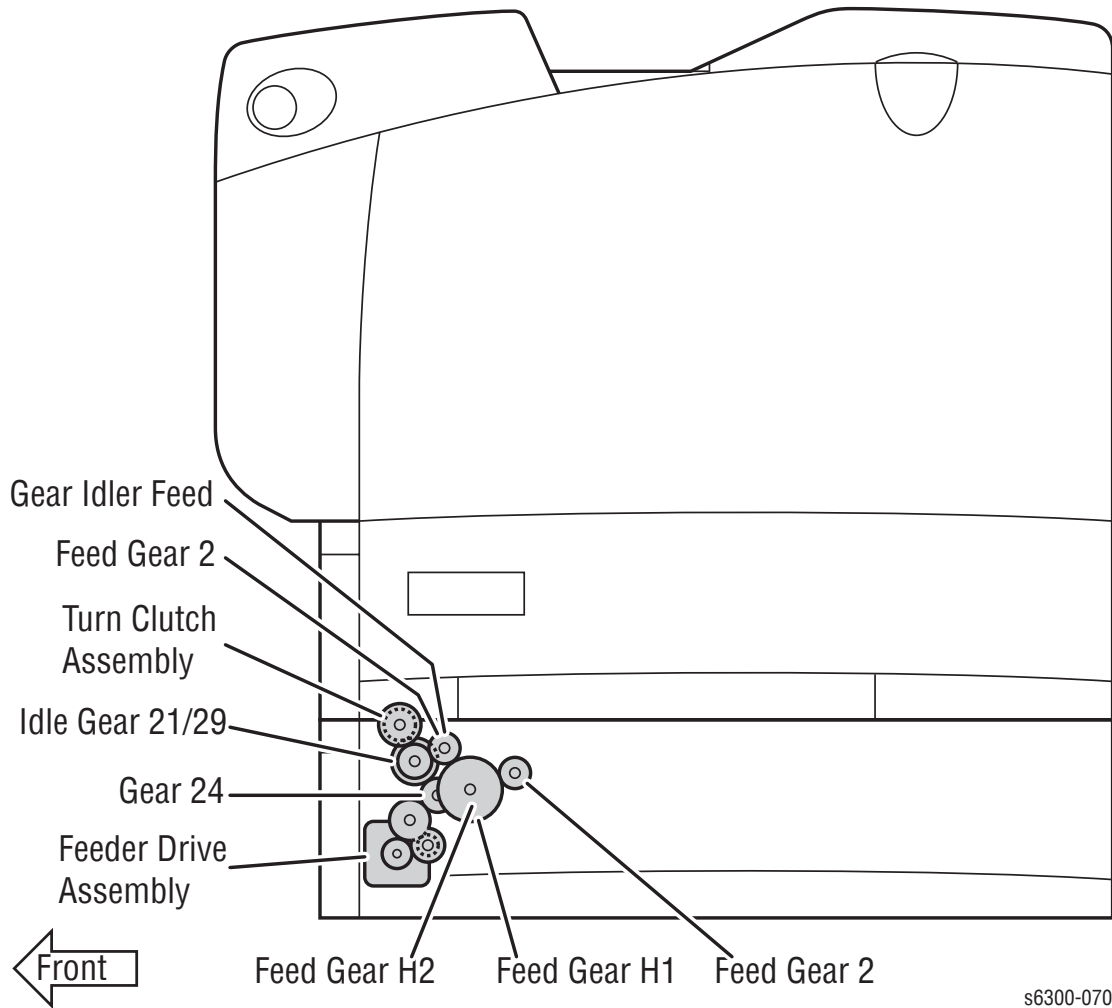

Error Messages and Codes

In this chapter...

- Introduction
- Servicing Instructions
- Messages, Codes, and Procedures

Section

3

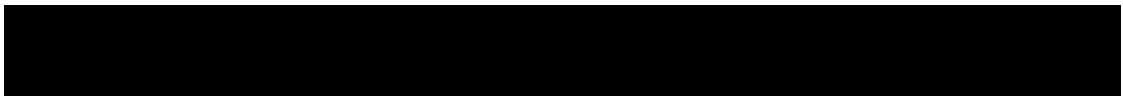

Introduction

This section describes error messages and numeric codes displayed on the Control Panel, listed on the Status page, or logged in the Service Usage Profile. These error indications serve as the entry point into the troubleshooting process. Along with the error message itself, help text including the associated code is available by pressing the **Help** (?) button. Printer problems not directly indicated by, or associated with an error message or code are covered in Chapter 4, "General Troubleshooting." Print-quality problems are covered in Chapter 5, "Print-Quality Troubleshooting."

The printer tracks and reports errors in a number of ways. The three types of error reporting discussed in this Section include:

- Error messages and help text displayed on the Control Panel.
- Fault Descriptions and Codes listed on the Status page.
- Engine (fatal) and Jam Error logs displayed on the Control Panel or listed in the Service Usage Profile.

Messages indicating the occurrence of either a fatal or jam error appear on the Control Panel and include their related code within the help text. Warning messages also appear, but in most cases do not have a corresponding code.

Accessing Fault History

Listed below are three ways in which you can access fault history records.

1. Print (if possible) the Status page from the **Troubleshooting** menu --> **Service Tools**. The fault history is listed on the second page of the report.
2. View the printer's fault history on the Control Panel. Go to **Troubleshooting** --> **Service Tools** --> **Engine Error History**.

Note

Definitions of the codes that appear in the fault history are given in "Printer Status Codes" on page A-4.

3. If the printer is connected to a network and has a TCP/IP address, view the printer's web page using a web browser.
 - a. Open a web browser.
 - b. Enter the printer's IP address as the URL.
 - c. Select the **Support** --> **Troubleshooting** --> **Diagnostics Logs** and the fault history displays.

If additional information is required, print the Service Usage Profile from **Troubleshooting** --> **Service Tools**.

Status Page

The Status page is a two-page report that provides general information about the printer, the consumables, the status of routine maintenance items, registration and color test patterns. The first page includes general information about the printer including firmware versions, page count, feature set, and consumables. Page 1 also provides color registration, calibration, and print target examples.

The second page provides a log of the last 50 errors with date, page count, description, and code. For a complete listing of all possible codes, refer to the "Printer Status Codes" on page A-4.

To print the Status page, go to the **Troubleshooting** menu, and then select **Service Tools**. The Status page appears as an option on the Service Tools menu.

Service Usage Profile

The Service Usage Profile tracks printer activity, consumable usage and printer status. This data is stored in NVRAM. Service Usage Profile data includes error logs that retain detail on the type, date, location and frequency of both engine and jam errors. While the Service Usage Profile includes data on all aspects of the printer, this section focuses on accessing these two error logs to review printer fault history. Only Engine (fatal) and jam errors are recorded in these two logs. Other errors and warnings are recorded elsewhere in the Service Usage Profile. Print the Status page for a complete history. The Error Message Summary table beginning on (page 3-6) lists all errors, their respective codes, and the page where the troubleshooting procedure begins.

Interpreting Error Logs

Error logs appear on the Control Panel as a list of semi-colon separated value pairs of the form <code>, <pg_count>;. The Engine and Jam Error Logs record the last 30 events. Log entries move top to bottom. Note that a value of 0 (zero) or "--" in a log indicates no data and <pg_count> is the Total Page count when the error occurred.

For example, the following provides a partial example of the Engine Error Log as it might appear on the display:

```
105,1460;  
0,0;  
0,0;  
0,0;  
0,0;
```

The 105,1460 pair indicates the printer recorded a Main Motor failure, represented by the code 105, at total page count 1460. The 0,0 pairs indicate no error activity. A printed log consists of several lines in the Service Usage Profile report (typically 2-5 lines). Each log typically includes an event code, a corresponding date, a corresponding page, and a total event counter. In the case of fatal errors, there are four lines (261-264). In the case of jams, there are five lines (291-295 and 298).

Servicing Instructions

The service checklist below is an overview of the path a service technician should take when servicing the printer and printer optional equipment.

Step 1 - Identify the Problem

1. Verify the reported problem does exist. Verify failure symptoms/behavior/noises with customer/end user.
2. Check for any error codes and write them down.
3. Print normal customer prints and service test prints.
4. Make note of any print quality problems in the test prints.
5. Make note of any mechanical or electrical abnormalities present.
6. Make note of any unusual noise or smell coming from the printer.
7. Print a Status page, if the printer is able to print.
8. View the fault history under the Service Tools Menu.
9. Verify the AC input power supply is within proper specifications.

Step 2 - Inspect and Clean the Printer

1. Switch Off printer power.
2. Disconnect the AC power cord from the wall outlet.
3. Verify the power cord is serviceable.
4. Remove the Imaging Unit and protect it from light.
5. Inspect the printer interior and remove any foreign matter, dust or loose toner.
 - Do not use solvents or chemical cleaners to clean the printer interior.
 - Do not use any type of oil or lubricant on printer parts.
 - Do not use canned air to clean spilled toner or dust from the printer.
 - Use only an approved toner vacuum.
6. Clean all rubber rollers with a lint-free cloth, dampened slightly with cold water.
7. Inspect the interior of the printer for damaged wires, loose connections, toner leakage, and damaged or obviously worn parts.
8. Replace damaged or empty Toner Cartridges with new, customer-supplied ones.

Step 3 - Find the Cause of the Problem

1. Read and understand the theory of how the printer operates.
2. Use the troubleshooting procedures to find the cause of the problem.
3. Use Service Diagnostics to check printer and optional components.
4. Use the wiring diagrams and plug/jack locator to locate test points.
5. Take voltage readings at various test points as instructed in the appropriate troubleshooting procedure.
6. Use the "Engine Test Print" on page 5-9, to isolate problems to the Engine or the Image Processor Board.

Step 4 - Correct the Problem

1. Use the Parts List to locate a part number.
2. Use the Disassembly Procedures to replace the part.

Step 5 - Final Check

Test the printer to be sure you have corrected the initial problem and verify there are no additional problems present.

Messages, Codes, and Procedures

The error messages and codes generated by the printer's operating system are the lead-in to the troubleshooting procedures that follow in subsequent pages. This section correlates the output of the printer's diagnostic aids and provides the troubleshooting procedure to locate and correct reported errors.

Error Message Abbreviations

Due to limited display space, some error messages include abbreviations. The most common abbreviations used throughout this chapter are listed here.

| Term | Definition | Comment |
|-------------|-----------------------------------|--|
| Reg or REGI | Registration | Used in designators such as Reg SNR |
| SNR | Sensor | Often seen as SNR1 or Reg SNR |
| DUP | Duplex | Optional for 2-sided printing |
| I/P Board | Image Processor | Image Processor Board |
| LTA | Lower Tray Assembly | Optional 550-Sheet Feeder (Tray 3) |
| HCF | High-Capacity Feeder | Optional 1100-Sheet Feeder |
| MSI or MPT | Multi-Sheet Input | Used to describe Tray 1 (MPT) |
| P/J | Plug/Jack | Plug (P) and or Jack (J) designators |
| SW | Switch | Appears as a designator. |
| NVM | Non-volatile Memory | Used instead of NVRAM. |
| CRUM | Customer-Replaceable Unit Monitor | Device used to store usage information on the Imaging Unit and Toner Cartridges. |
| Comm | Communication | As in Comm Error |
| TNR | Toner | Used as an abbreviation for Toner |
| FDR | Feeder | Used as an abbreviation for Feeder |
| FSR | Fuser | Used as an abbreviation for Fuser |
| CTD/ADC | Toner Density Control | Designator for the CTD/ADC Sensor |
| LVPS | Low-Voltage Power Supply | Primary power supply |
| PWB | Printed Wire Board | Used to describe a circuit board |
| HVPS | High-Voltage Power Supply | Supplies voltages to the Imaging and Laser units |

Error Message Summary

The Error Message Summary table lists possible errors, along with the corresponding code, and page reference for the corrective procedure. The Control Panel Message column shows the message as it appears on the printer's display when the error occurs during normal operation. The Code column lists codes listed on the printer Status page, logged by the Service Usage Profile, and displayed by the Diagnostic Fault History utility. For fatal and jam errors, these codes also appear in Help text. The Go to Page column references the procedure related to the error. Use this table to identify the proper procedure to clear the reported error.

Note

Appendix A includes a complete list of Codes arranged in numeric order.

Error Message Summary

| Control Panel Message | Code | Go to Page |
|--|----------------------------------|------------|
| Jam Errors | | |
| Jam at Fuser; Open Front Door B to Clear | 152 | 3-11 |
| Jam at Duplex; Open Front Door B to Clear | 153 | 3-13 |
| Jam at Registration Roller | 154 | 3-15 |
| Misfeed at Tray 1 (MPT); Open Front Door A to Clear | 155 | 3-17 |
| Misfeed at Tray 2; Open Tray and Front Door A to Clear | 156 | 3-20 |
| Misfeed at Tray 3; Open Tray and Front Door A to Clear | 157 | 3-23 |
| Misfeed at Tray 4; Open Tray and Front Door A to Clear | 158 | 3-26 |
| Misfeed at Tray 5; Open Tray and Front Door A to Clear | 159 | 3-29 |
| Door and Cover Errors | | |
| Close Front Door | 150 | 3-31 |
| Consumable/Routine Maintenance Item Errors | | |
| Non-Phaser 6300/6350 Fuser | 94 | 3-50 |
| Non-Xerox Imaging Unit | 95 | 3-52 |
| Replace [C][M][Y][K] Toner Cartridge | 90, 91, 92, 93 96, 97, 98, 99 | 3-48 |
| Replace Maintenance Kit | 101 | 3-51 |
| Dusty Density Sensor | 151 | 3-44 |
| Replace [C][M][Y][K] Toner Cartridge | 202, 203, 204, 205 | 3-42 |
| Replace Imaging Unit | 196 | 3-34 |
| Replace Transfer Roller | 197 | 3-37 |
| Replace Transfer Roller | 206 | 3-37 |
| Replace Fuser | 207 | 3-39 |

Error Message Summary (Continued)

| Control Panel Message | Code | Go to Page |
|--|--------------------|------------|
| Consumable/Routine Maintenance Item Errors (Continued) | | |
| Install or Lock [C][M][Y][K] Toner Cartridge | 208, 209, 210, 211 | 3-41 |
| Install or Reseat Imaging Unit | 212 | 3-33 |
| Install or Reseat Transfer Roller | 213 | 3-35 |
| Install or Reseat Fuser | 214 | 3-38 |
| Remove Ribbon from [C][M][Y][K] Toner Cartridge; Unlock And Lock Cartridge To Clear | 215, 216, 217, 218 | 3-45 |
| Metered Toner is not Enabled | 223 | 3-53 |
| Replace [C][M][Y][K] Toner Cartridge | 224, 225, 226, 227 | 3-42 |
| Tray and Media Errors | | |
| Insert Tray 2 | 160 | 3-54 |
| Insert Tray [3][4][5] | 161, 162, 163 | 3-55 |
| Out of Paper Load Tray 1(MPT) with [size] [type] | 165 | 3-57 |
| Out of Paper Load Tray [2][3][4][5] with [size] [type] | 166, 167, 168, 169 | 3-58 |
| Output Tray is Full, Unload Paper | 191 | 3-60 |
| Media Mismatch Errors | | |
| Wrong Paper Size Load Tray 1 (MPT) with [size] [type] | 176 | 3-61 |
| Wrong Paper Size Load Tray [2][3][4][5] with [size] [type] | 177, 178, 179, 180 | 3-63 |
| Configuration Errors | | |
| Invalid Configuration Card | – | 3-64 |
| Configuration Card Missing | – | 3-64 |
| Fatal Errors | | |
| Laser Failure [code] | 7, 8, 9, 10, 11 | 3-66 |
| Density Sensor Failure [code] | 13, 14, 15, 16 | 3-67 |
| Fuser Failure [code] | 40, 41, 42, 43 | 3-68 |
| Fuser Failure 44 | 44 | 3-69 |
| Fuser Failure [code] | 45, 46, 47 | 3-70 |
| Fuser Fan Failure | 50 | 3-71 |
| Rear Fan Failure | 51 | 3-72 |
| Fan Failure | 52 | 3-73 |
| Fuser Firmware Failure | 76 | 3-74 |
| Engine Firmware Failure [code] | 70, 71, 73, 74, 79 | 3-75 |
| Engine Firmware Failure [code] | 72, 78 | 3-75 |
| Image Density Error | 77 | 3-84 |

Error Message Summary (Continued)

| Control Panel Message | Code | Go to Page |
|--|----------------|------------|
| Fatal Errors (Continued) | | |
| Disk Failure | 80 | 3-83 |
| Engine NVRAM Failure | 83 | 3-76 |
| [C][M][Y][K] Toner Cartridge Failure | 86, 87, 88, 89 | 3-77 |
| Environmental Sensor Failure | 102 | 3-78 |
| Fuser Motor Failure | 103 | 3-79 |
| Developer Motor Failure | 104 | 3-80 |
| Main Motor Failure | 105 | 3-81 |
| Motor Failure | 106 | 3-82 |
| Warning Messages | | |
| Tray 2 is missing | – | 3-54 |
| Tray [3][4][5] is missing | – | 3-55 |
| No Paper in Tray [2][3][4][5] | – | 3-58 |
| Tray 2 Paper is Low | – | 3-46 |
| Tray [3][4][5] Paper is Low | – | 3-47 |
| [C][M][Y][K] Toner is Low | – | 3-42 |
| Dusty Density Sensor | – | 3-44 |
| Imaging Unit is Near End of Life | – | 3-34 |
| Transfer Roller is at End of Life | – | 3-37 |
| Replace Fuser | – | 3-39 |
| Non-Xerox [C][M][Y][K] Toner Cartridge | – | 3-48 |
| Replace Maintenance Kit | 101 | 3-51 |
| Unsupported Configuration | 164 | 3-65 |
| Duplicate IP address detected | – | 3-65 |

Note

Warning messages do not have assigned codes. However, for reporting reasons, the Replace Maintenance Kit and Unsupported Configuration warnings have been assigned codes.

Using the Troubleshooting Procedures

1. **Applicable Status Code(s)** lists the error message(s) addressed by each troubleshooting procedure.
2. **Applicable Parts** and **Wiring and Plug/Jack References** assist you in locating information available for a particular part or procedure.
3. Follow each **Step** in a troubleshooting procedure sequentially in the order given until the problem is fixed or resolved.
4. The **Actions and Questions** box instructs you to perform a certain action or procedure. Also included are precautions and/or additional procedures you must follow to isolate the problem.
5. When a procedure instructs you to test a component using Service Diagnostics, see "Service Diagnostics" on page 4-6 for the detailed steps and functions for testing parts, assemblies, or subsystems of the printer.
6. Some actions are followed by a question. If your response to the question is **Yes**, then follow the instructions for a **Yes** reply. If your response to the question is **No**, then follow the instructions for a **No** reply.
7. Note that two types of photo sensors are used: photo-reflective and photo-receptive. Photo-reflective sensors use light reflected back from an object to detect its presence or absence. Photo-receptive sensors use an actuator or the object itself to block the light path to detect an object or condition.
8. Troubleshooting procedures frequently ask you to take voltage readings or test for continuity or resistance at certain test points. The **Wiring and Plug/Jack References** table provides pointers to the diagrams that provide this information.
9. Troubleshooting procedures often ask you to replace a printer component. When instructed to replace a non-spared component and that component is part of a parent assembly, replace the entire parent assembly.

Measurement Techniques

1. Unless indicated otherwise, the instruction "switch On printer power" means for you to switch On printer power and let the printer proceed through Power On Self Test (POST) to a 'Ready' condition.

2. Conventions used in this manual to represent connectors



s6300-081

3. When instructed to take voltage, continuity or resistance readings on wiring harness, proceed as follows; Check P/J 232–1 to P/J 210–5 by placing the red probe (+) of your meter on pin 1 of P/J 232, and place the black probe (–) of your meter on pin 5 of P/J 210.

4. When you are instructed to take resistance readings between “P/J 232 <=> P/J 210” (without specified pin numbers), check all pins. Refer to the section "Wiring Diagrams" on page 10-13 for the location of all wiring harnesses and pins.
5. When you are instructed to run a test, run the Service Diagnostics test associated with the component being examined.
6. When you are instructed to take a voltage reading, the black probe (–) is generally connected to a pin that is either RTN (Return) or SG (Signal Ground). You can substitute any RTN pin or test point in the printer, and you can use FG (frame ground) in place of any SG pin or test point.
7. Before measuring voltages make sure the printer is switched On, the Imaging Unit and the paper trays are in place, and the interlock switch is actuated, unless a troubleshooting procedure instructs otherwise.
8. All voltage values given in the troubleshooting procedures are approximate values. The main purpose of voltage readings is to determine whether or not a component is receiving the correct voltage value from the power supply and if gating (a voltage drop) occurs during component actuation. Gating signals may be nothing more than a pulse, resulting in a momentary drop in voltage that may be difficult or impossible to read on the average multi-meter.
9. When a troubleshooting procedure instructs you to replace a non-spared component and that component is part of a parent assembly, you should replace the entire parent assembly.
10. Ensure that you are using a supported media size and type, refer to "Media and Tray Specifications" on page 1-17.
11. Power and signal grounds are connected to the frame ground. All circuit troubleshooting can be performed using the metal frame (chassis) as the grounding point. To locate connectors or test points, refer to the section "Plug/ Jack Locator Maps" on page 10-2 or "Wiring Diagrams" on page 10-13 for more information.

Unless otherwise specified, the following voltage tolerances are used within this section:

| Stated | Measured |
|---------------|----------------------|
| +3.3 VDC | +3.135 to +3.465 VDC |
| +5.0 VDC | +4.75 to +5.25 VDC |
| +24.0 VDC | +21.6 to +26.4 VDC |
| 0.0 VDC | Less than +0.5 VDC |

Jam Error Procedures

Jam at Fuser: Jam F

Paper did not reach the Exit Sensor on time or the Exit Sensor indicates that paper remains in the Fuser Exit Roller.

Applicable Status Code:

Code 152: Jam at Fuser

Initial Actions:

- Remove the Fuser and check for any obstructions, media, damage, or debris.
- Cycle printer power.
- If the problem persists, follow the procedure below.

Troubleshooting Reference Table

| Applicable Parts | Wiring and Plug/Jack References |
|---|---|
| <ul style="list-style-type: none">■ Fuser, PL5.1.1■ Exit Sensor Actuator, PL5.1.2■ Fuser Drive Assembly, PL5.2.25 | <ul style="list-style-type: none">■ Print Engine LVPS and Drive P/J Locator (page 10-6)■ Print Engine Drive Wiring Diagram (page 10-19)■ Print Engine Fuser Wiring (page 10-22) |

Warning

To avoid the potential of electric shock, ensure the power to the printer is off and the power cord is disconnected from the wall outlet prior to performing Step 2 of the following troubleshooting procedure.

Caution

Allow adequate time for the Fuser to cool before servicing the printer.

Troubleshooting Procedures Table

| Step | Action and Questions | Yes | No |
|------|---|--|--|
| 1 | <p>Check the following for evidence of fault or damage:</p> <ul style="list-style-type: none"> ■ Exit Actuator and Sensor, PL5.1.2 and PL5.1.3 ■ Fuser Assembly, PL5.1.1 ■ Front Cover, PL1.1.6 ■ Chute Assembly In, PL5.2.1 ■ Transfer Roller, PL5.1.4 ■ Imaging Unit, PL6.1.1 <p>Is there any damage?</p> | Replace any damaged parts. | Go to Step 2. |
| 2 | Remove the Fuser and check for broken or bent pins. | Replace the parts concerned. | Go to Step 3. |
| 3 | Reinstall the Fuser. Does error recur after the Fuser Assembly has been replaced? | Go to Step 4. | Complete |
| 4 | Test the Exit Sensor. Run the Service Diagnostics Exit Sensor Test. Does the sensor function correctly? | Go to Step 7. | Go to Step 5. |
| 5 | Check the Exit Sensor Signal. Insert a sheet of paper into the Fuser. Is the voltage across J361-A5 <=> J361-A6 0 V? | Go to Step 7. | Go to Step 6. |
| 6 | Check all pins on the FSR/ADC Harness PL5.2.28 for continuity. 1. Disconnect P/J361 and P/J36. 2. Check continuity between J361<=>J36. | Go to Step 7. | Replace the FSR/ADC Harness. |
| 7 | If possible print one sheet of paper. Does the Fuser Motor Turn? | Inspect and replace defective gear(s). | Go to Step 8. |
| 8 | Test the Fuser Drive Assembly. Run the Service Diagnostics Fuser Motor test. Does the Fuser Motor function correctly? | Replace the Engine Control Board (page 8-104). | Go to Step 10. |
| 9 | Check for +24 V to the Fuser Motor. Disconnect P/J521. Is there +24 V across J521-10 <=> ground? | Go to Step 11. | Replace the Engine Control Board (page 8-104). |
| 10 | Replace the Fuser Drive Assembly. Does the Fuser Motor function correctly? | Complete | Go to Step 11. |
| 11 | Check TNRFULL/FSR Harness continuity. 1. Disconnect P/J52 and P/J521. 2. Check continuity between J52 <=> J521. | Replace the Engine Control Board (page 8-104). | Replace the TNRFULL/FSR Harness. |

Jam at Duplex: Jam D

The Duplex Jam Sensor indicates that paper did not reach the sensor on time or that paper remains in the Chute Assembly Out.

Applicable Status Code:

Code 153: Jam at Duplex

Initial Actions:

- Check for obstructions or debris in the Chute Assembly Out or paper path.
- Cycle printer power.
- If the problem persists, follow the procedure below.

Troubleshooting Reference Table

| Applicable Parts | Wiring and Plug/Jack References |
|---|---|
| <ul style="list-style-type: none">■ Duplex Jam Sensor, PL5.4.1■ Jam Sensor Actuator, PL5.4.13■ Duplex Motor Assembly, PL5.4.5■ FRONT/DUP Harness, PL5.3.28■ Chute Assembly Out, PL5.3.1 | <ul style="list-style-type: none">■ Print Engine Map 1 P/J Locator (page 10-5)■ Print Engine Drive Wiring Diagram (page 10-19)■ Print Engine Paper Feed Wiring (page 10-26) |

Troubleshooting Procedures Table

| Step | Action and Questions | Yes | No |
|------|--|---------------------------|--|
| 1 | Check the following for evidence of fault or damage: <ul style="list-style-type: none">■ Duplex Motor Assembly, PL5.4.5■ JAM Sensor Actuator, PL5.4.13■ Chute Assembly Out, PL5.3.1 Are there any defects? | Replace any damaged part. | Go to Step 2. |
| 2 | Test the Duplex Jam Sensor. Run the Service Diagnostics Jam Sensor test. Does the sensor function correctly? | Go to Step 7. | Replace the Duplex Jam Sensor and Go to Step 3. |
| 3 | Check printer function. Does the printer function correctly after replacing the Duplex Jam Sensor? | Complete | Go to Step 4. |
| 4 | Check the Duplex Jam Sensor signal. Block the Duplex Jam Sensor. Is the voltage across J133-1 <=> J133-2 0 V? | Go to Step 6. | Go to Step 5. |

Troubleshooting Procedures Table (Continued)

| Step | Action and Questions | Yes | No |
|------|--|--|--|
| 5 | Check FRONT/DUP Harness continuity. 1. Disconnect P/J133 and P/J13. 2. Check continuity between J133 <=> J13 | Go to Step 6. | Replace the FRONT/DUP Harness. |
| 6 | Print a Test Print in Duplex mode Does the sheet reverse in the printer? | Replace the Chute Assembly Out (page 8-61). | Go to Step 7. |
| 7 | Test the Duplex Motor. 1. Close the Interlock Switch during the test. 2. Run the Service Diagnostics Duplex Motor test. Does the Duplex Motor function correctly? | Replace the Chute Assembly Out (page 8-61). | Go to Step 8. |
| 8 | Check for +24 V to the Duplex Motor. Disconnect P/J501. Is there +24 V across P501-6 <=> ground? | Go to Step 9. | Replace the Engine Control Board (page 8-104). |
| 9 | Check all pins on the FRONT/DUP Harness PL5.3.28 for continuity. 1. Disconnect P/J13 and P/J501. 2. Check continuity between J13 <=> P501. | Go to Step 10. | Replace the FRONT/DUP Harness. |
| 10 | Replace the Duplex Motor. Does the error persist? | Replace the Engine Control Board (page 8-104). | Complete |

Jam at Registration Roller: Jam RR

The Registration Sensor indicates that paper did not reach the sensor on time or that paper remains in the Registration Chute.

Applicable Status Code:

Code 154: Registration Jam

Initial Actions:

- Ask the customer about the paper types being used. If not on the recommended list, determine if this is contributing to the problem. Recycled, multi-purpose or copier paper tends to contaminate the paper path. Constant use of special papers such as labels or business cards can also contribute to jamming.
- Ensure the correct tray loading and setup procedures are followed (securing the guides, selecting the correct paper type, fanning the paper, etc.).
- Make sure the printer is plugged directly into an electrical outlet. Using extension cords or a power strip is not recommended.
- Make every attempt to establish a jam rate prior to starting any work. If possible print a Status page or Usage Profile report and note the page count between jams.
- Determine if jamming is occurring in one tray but not another. This helps to identify any dirty or defective parts.
- Clear the paper path of any Jams and paper debris. Start at the Turn Chute and work up to the Registration Chute Assembly.
- Clean the paper Feed and Pick Rollers in the paper tray and tray slot using a slightly damp (water only) lint free cloth.
- Cycle printer power.
- If the problem persists, follow the procedure below.

Note

In some instances the error will clear after power is cycled, but reappears with the next print. Check for a piece of paper fan-folded behind the Feeder Chute (PL3.1.2) or below the Registration Roller Assembly (PL4.2.1).

Troubleshooting Reference Table

| Applicable Parts | Wiring and Plug/Jack References |
|---|---|
| ■ Registration Sensor, PL4.1.3 | ■ Print Engine Map 3 P/J Locator (page 10-7) |
| ■ Registration Sensor Actuator, PL4.1.1 | ■ Print Engine Paper Feed Wiring (page 10-26) |
| ■ Registration Roller Assembly, PL4.2.1 | |

Troubleshooting Procedure Table

| Step | Action and Questions | Yes | No |
|------|--|---|--|
| 1 | <p>Check the following for damage.</p> <ul style="list-style-type: none"> ■ Registration Sensor Actuator, PL4.1.1 ■ Registration Roller Assembly, PL4.2.1 <p>Is there any damage?</p> | Clean or replace as needed. | Go to Step 2. |
| 2 | <p>Test the Registration Sensor.</p> <p>Run the Service Diagnostics Registration Sensor test.</p> <p>Does the sensor function correctly?</p> | Go to Step 6. | Go to Step 3. |
| 3 | <p>Check the Registration Sensor connection.</p> <p>Is the Registration Sensor connected to the harness?</p> | Go to Step 4. | Reconnect. |
| 4 | <p>Check all pins on the REGISNS Harness PL 4.1.4 for continuity.</p> <ol style="list-style-type: none"> 1. Disconnect P/J181 and P/J18. 2. Check continuity between J181 <=> J18. | Go to Step 5. | Replace the Registration Sensor Harness. |
| 5 | <p>Check the Registration Sensor signal.</p> <p>Block the Registration Sensor.</p> <p>Verify the voltage between P/J18-3 <=> P/J18-2 on the Engine Control Board is 0 VDC.</p> | Go to Step 6. | Replace the Registration Sensor (page 8-36). |
| 6 | <p>Test the Registration Clutch.</p> <ol style="list-style-type: none"> 1. Close the Interlock Switch while testing. 2. Run the Service Diagnostics Registration Clutch test. <p>Does the clutch function correctly?</p> | Go to Step 8. | Go to Step 7. |
| 7 | <p>Check the Registration Clutch resistance.</p> <p>Disconnect connector P/J192.</p> <p>Is the resistance between J192-1 <=> J192-2 less than 200Ω?</p> | Go to Step 8. | Replace the Registration Clutch (Part of the Registration Roller Assembly) |
| 8 | <p>Check for +24 V to the Registration Clutch.</p> <ol style="list-style-type: none"> 1. Disconnect P/J192. 2. Close the Interlock Switch while testing. <p>Is there +24 V across P192-3 <=> ground?</p> | Replace the Registration Chute (page 8-38). | Replace the Engine Control Board (page 8-104). |

Misfeed at Tray 1 (MPT): Jam T1

Paper fed from Tray 1 (MPT) did not reach the Registration Sensor on time.

Applicable Status Code:

Code 155: Misfeed at Tray 1

Initial Actions:

- Ensure that Tray 1(MPT) is securely attached to the printer.
- Try picking paper from a different tray.
- Check the paper path for obstructions or debris.
- Ensure that the media guides are set correctly.
- Cycle printer power.
- If the problem persists, follow the procedure below.

Troubleshooting Reference Table

| Applicable Parts | Wiring and Plug/Jack References |
|--|--|
| <ul style="list-style-type: none">■ Feed Roller Assembly MPT, PL5.3.20■ Interlock Switch, PL9.1.11■ Registration Sensor, PL4.1.3■ Feed Solenoid, PL5.3.9■ Registration Roller Assembly, PL4.2.1■ Main Drive Assembly, PL8.1.2 | <ul style="list-style-type: none">■ Print Engine Map 1 P/J Locator (page 10-5)■ Print Engine Power Wiring Diagram (page 10-17)■ Print Engine Drive Wiring Diagram (page 10-19)■ Print Engine Paper Feed Wiring (page 10-26) |

Troubleshooting Procedure Table

| Step | Actions and Questions | Yes | No |
|------|--|--|---------------|
| 1 | Check the following for evidence of fault or damage: <ul style="list-style-type: none">■ Feed Roller Assembly MPT, PL5.3.20■ Tray 1 (MPT)■ Registration Sensor, PL4.1.3■ Main Drive Assembly, PL8.1.2 Remove any foreign objects or paper debris from the paper path. Is there any damage? | Replace any damaged or excessively worn parts. | Go to Step 2. |
| 2 | Test the Registration Sensor. Run the Service Diagnostics Registration Sensor test. Does the sensor function correctly? | Go to Step 6. | Go to Step 3. |

Troubleshooting Procedure Table (Continued)

| Step | Actions and Questions | Yes | No |
|------|---|--|--|
| 3 | Check the Registration Sensor connection. Is the Registration Sensor connected to the harness? | Go to Step 4. | Connect the sensor. |
| 4 | Check all pins of the REGISNR Harness PL4.1.4 for continuity. 1. Disconnect P/J181 and P/J18. 2. Check continuity between J181 <=> J18. | Go to Step 5. | Replace the Registration Sensor Harness. |
| 5 | Check the Registration Sensor signal. Block the Registration Sensor. Verify the voltage between P/J18-3 <=> P/J18-2 on the Engine Control Board is 0 VDC. | Replace Registration Sensor (page 8-36). | Go to Step 6. |
| 6 | If possible, print a Test Print from Tray 1 (MPT). Does the Main Motor function properly? | Go to Step 16 | Go to Step 7 |
| 7 | Test the Main Drive Assembly. Run the Service Diagnostics Main Motor test. Does the Main Motor turn? | Replace the Engine Control Board (page 8-104). | Go to Step 8. |
| 8 | Check for +24 V to the Main Drive Motor 1. Disconnect P/J481. 2. Close the Interlock Switch while testing. Is there +24 V across J481-10 <=> J481-8? | Go to Step 12. | Go to Step 9. |
| 9 | Test the Interlock Switch. Run the Service Diagnostics Interlock Switch test. Does the Interlock Switch function correctly? | Go to Step 11. | Go to Step 10. |
| 10 | Check for +5 V to the Interlock Switch Disconnect P/J161. Is there +5 V across P161-1 <=> P161-2? | Replace the LVPS. | Replace the Interlock Switch (page 8-101). |
| 11 | Check FAN/PHD/MOT Harness continuity. 1. Disconnect P/J48 and P/J481. 2. Check continuity between J48 <=> J481 | Replace Main Drive Motor | Replace FAN/PHD/MOT Harness. |
| 12 | Check Turn Roller function. 1. Perform Steps 1 ~ 3 on (page 8-21). 2. Open and close the front door. 3. Observe the Turn Roller. Does the Turn Roller turn while the machine is warming up? | Go to Step 16. | Go to Step 13. |

Troubleshooting Procedure Table (Continued)

| Step | Actions and Questions | Yes | No |
|-----------|---|--|---|
| 13 | Test the Turn Clutch. 1. Run the Service Diagnostics Tray 1 (MPT) Turn Clutch test. 2. Close the Interlock Switch while testing. Does the Turn Clutch function normally? | Check that the Clutch doesn't slip. Check the gears for damage. | Go to Step 14. |
| 14 | Check for +24 V to the Turn Clutch. 1. Disconnect P/J191. 2. Close the Interlock Switch while testing. Is there +24 V across P191-2 <=> ground? | Go to Step 15. | Replace the Engine Control Board (page 8-104). |
| 15 | Check Turn Clutch resistance. Disconnect P/J191. Is the resistance between J191-1 <=> J191-2 less than 200Ω? | Go to Step 16. | Replace the Turn Clutch (Part of the Registration Roller Assembly). |
| 16 | If possible, print a Test print from Tray 1 (MPT). Check the Feed Gear operation. Does the gear function normally? | Check for damage or obstructions in the paper path. | Go to Step 17. |
| 17 | Test the Feed Solenoid. 1. Close the Interlock Switch while testing. 2. Run the Service Diagnostics Tray 1 (MPT) Feed Solenoid test. Does the Feed Solenoid function normally? | Check that the Feed Solenoid spring and stopper disengage correctly. | Go to Step 18. |
| 18 | Check all pins on the FRONT/DUP Harness PL5.3.28 for continuity. 1. Disconnect P/J132 and P/J13. 2. Check continuity between J13 <=> P132. | Go to Step 19. | Replace the FRONT/DUP Harness Assembly. |
| 19 | Check Feed Solenoid resistance. Disconnect connector P/J132. Is the resistance between J132-1 <=> J132-2 less than 100Ω? | Replace the Engine Control Board (page 8-104). | Replace the Feed Solenoid. |

Misfeed at Tray 2: Jam T2

Paper fed from Tray 2 did not reach the Registration Sensor on time.

Applicable Status Code:

Code 156: Misfeed at Tray 2

Initial Actions:

- Try picking paper from a different tray.
- Ensure that Tray 2 is installed properly and the paper guides are set correctly.
- Remove, fan, and reload supported media in Tray 2.
- Remove any obstructions or debris in the paper path and cycle printer power.
- If the problem persists, follow the procedure below.

Troubleshooting Reference Table

| Applicable Parts | Wiring and Plug/Jack References |
|---|---|
| <ul style="list-style-type: none">■ Feed Rollers, PL3.3.18■ Interlock Switch, PL9.1.11■ Registration Sensor, PL4.1.3■ Registration Roller PL4.2.1■ Main Drive Assembly, PL8.1.2■ Tray 2 Paper Pick Assembly, PL3.3.1 | <ul style="list-style-type: none">■ Print Engine Map 1 P/J Locator (page 10-5)■ Print Engine Map 4 Tray 2 P/J Locator (page 10-8)■ Print Engine Tray 2 Wiring (page 10-18)■ Print Engine Drive Wiring Diagram (page 10-19)■ Print Engine Paper Feed Wiring (page 10-26) |

Troubleshooting Procedure Table

| Step | Actions and Questions | Yes | No |
|------|--|--|---------------------|
| 1 | Check the following for evidence of fault or damage: <ul style="list-style-type: none">■ Feed Rollers, PL3.3.18■ Paper Pick Assembly, PL3.3.1■ Tray 2, PL2.1.1■ Registration Sensor, PL4.1.3■ Main Drive Assembly, PL8.1.2 | Replace any damaged or excessively worn parts. | Go to Step 2. |
| 2 | Test the Registration Sensor. Run the Service Diagnostics Registration Sensor test. Does the sensor function correctly? | Go to Step 6. | Go to Step 3. |
| 3 | Check the Registration Sensor connection. Is the Registration Sensor connected to the harness? | Go to Step 4. | Connect the sensor. |

Troubleshooting Procedure Table (Continued)

| Step | Actions and Questions | Yes | No |
|------|---|--|--|
| 4 | Check all pins on the REGISNS Harness PL4.1.4 for continuity. 1. Disconnect P/J181 and P/J18. 2. Check continuity between J181 <=> J18 | Go to Step 5. | Replace the Registration Sensor Harness. |
| 5 | Check the Registration Sensor signal. Block the Registration Sensor. Is the voltage across P/J18-3 <=> P/J18-2 0 V? | Replace Registration Sensor (page 8-36). | Go to Step 6. |
| 6 | If possible, print a Test Print from Tray 1 (MPT). Does the Main Motor function properly? | Go to Step 16. | Go to Step 7. |
| 7 | Test the Main Drive Assembly. Run the Service Diagnostics Main Motor test. Does the Main Motor turn? | Replace the Engine Control Board (page 8-104). | Go to Step 8. |
| 8 | Check for +24 V to the Main Drive Motor 1. Disconnect P/J481. 2. Close the Interlock Switch while testing. Is there +24 V across J481-10 <=> J481-8? | Go to Step 12. | Go to Step 9. |
| 9 | Test the Interlock Switch. Run the Service Diagnostics Interlock Switch test. Does the Interlock Switch function correctly? | Go to Step 11. | Replace the parts concerned. |
| 10 | Check for +5 V to the Interlock Switch Disconnect P/J161. Is there +5 V across P161-1 <=> P161-2? | Replace the LVPS. | Replace the Interlock Switch (page 8-101). |
| 11 | Check all pins on the FAN/PHD/MOT Harness PL10.1.9 for continuity. 1. Disconnect P/J48 and P/J481. 2. Check continuity between J48 <=> J481. | Replace Main Drive Motor | Replace FAN/PHD/MOT Harness. |
| 12 | Check Turn Roller function. 1. Perform Steps 1 through 3 on (page 8-21). 2. Open and close the front door. 3. Observe the Turn Roller. Does the Turn Roller turn while the machine is warming up? | Go to Step 16. | Go to Step 13 |
| 13 | Test the Turn Clutch. 1. Close the Interlock Switch while testing. 2. Run the Service Diagnostics Tray 1 (MPT) Turn Clutch test. Does the Turn Clutch function normally? | Check that the Clutch doesn't slip. Check the gears for damage. | Go to Step 14. |

Troubleshooting Procedure Table (Continued)

| Step | Actions and Questions | Yes | No |
|------|--|--|--|
| 14 | Check for +24 V to the Turn Clutch. 1. Disconnect P/J191. 2. Close the Interlock Switch while testing. Is there +24 V across P191-2 <=> ground? | Go to Step 15. | Replace the Engine Control Board (page 8-104). |
| 15 | Check all pins on the FRONTCLH Harness PL4.1.21 for continuity. 1. Disconnect P/J191 and P/J19. 2. Check continuity between J19 <=> P191. | Go to Step 16. | Replace the FRONTCLH Harness Assembly. |
| 16 | Check Turn Clutch resistance. Disconnect P/J191. Is the resistance between J191-1 <=> J191-2 less than 200Ω? | Replace the Engine Control Board (page 8-104). | Replace the Turn Clutch (Part of the Registration Roller Assembly). |
| 17 | Check the Tray 2 Feed Solenoid. If possible, print a Test print from Tray 2. Does the Feed Gear operate correctly? | Replace any damaged or excessively worn parts. | Go to Step 18. |
| 18 | Test the Tray 2 Feed Solenoid. 1. Close the Interlock Switch while testing. 2. Run the Service Diagnostics Tray 2 Feed Solenoid test. Does the Feed Solenoid function normally? | Check the Solenoid Feed spring and stopper. | Go to Step 19. |
| 19 | Check all pins on the FDR Harness PL3.3.22 for continuity. 1. Disconnect P/J474 and P/J47. 2. Check continuity between J47 <=> P474. | Go to Step 20. | Replace the FDR Harness. |
| 20 | Check Feed Solenoid resistance. Disconnect connector P/J474. Is the resistance between J474-1 <=> J474-2 less than 100Ω? | Replace the Engine Control Board (page 8-104). | Replace Tray 2 Feed Solenoid (Part of the Tray 2 Paper Pick Assembly). |

Misfeed at Tray 3: Jam T3

Paper being fed from either the 550-Sheet Feeder or the top tray of the 1100-Sheet Feeder did not reach the Registration Sensor on time.

Applicable Status Code:

Code 157: Feed Jam

Initial Actions:

- Try picking paper from a different tray.
- Ensure that Tray 3 is installed properly and the paper guides are set correctly.
- Remove, fan, and reload supported media in Tray 3.
- Remove any obstructions or debris in the paper path and cycle printer power.
- If the problem persists, follow the procedure below.

Troubleshooting Reference Table

| Applicable Parts | Wiring and Plug/Jack References |
|---|--|
| For 550-Sheet Feeder: <ul style="list-style-type: none">■ Feed Rollers, PL11.3.20■ Paper Pick Assembly, PL11.3.1■ Drive Assembly, PL11.3.15■ OPFDR Harness, PL11.3.24■ OPTFDR Board, PL11.1.10■ OPFPLG Harness, PL11.1.13 | <ul style="list-style-type: none">■ 550-Sheet Feeder P/J Locator (page 10-12)■ 550-Sheet Feeder Tray 3 Wiring (page 10-35)■ 550-Sheet Feeder Drive Wiring (page 10-34)■ 1100-Sheet Feeder P/J Locator (page 10-10)■ 1100-Sheet Feeder Tray 3 Wiring (page 10-31)■ 1100-Sheet Feeder Drive Wiring (page 10-30) |
| For 1100-Sheet Feeder: <ul style="list-style-type: none">■ Feed Rollers, PL12.4.19■ Paper Pick Assembly, PL12.4.1■ Drive Assembly, PL12.3.9■ OPFDR Harness, PL12.3.7■ OPTFDR Board, PL12.3.3■ OPFREC2 Harness, PL12.3.1 | |

Troubleshooting Procedure Table

| Step | Actions and Questions | Yes | No |
|------|--|---------------|--|
| 1 | Check the printer paper path. Does paper feed correctly from Tray 2? | Go to Step 2. | See "Misfeed at Tray 2 Jam T2" on page 3-20. |
| 2 | If possible, print a Test print from Tray 3. Does the Drive Assembly operate? | Go to Step 9. | Go to Step 3. |

Troubleshooting Procedure Table (Continued)

| Step | Actions and Questions | Yes | No |
|-----------|---|---|-----------------------------|
| 3 | <p>Test the Drive Motor.</p> <ol style="list-style-type: none"> 1. Close the Interlock Switch while testing. 2. Run the Service Diagnostics HCF/LTA Motor test. <p>Does the Drive Motor function correctly?</p> | Replace the Engine Control Board (page 8-104). | Go to Step 4. |
| 4 | <p>Check for +24 V to the Drive Motor.</p> <ol style="list-style-type: none"> 1. Disconnect P/J82. 2. Close the Interlock Switch while testing. <p>Is the voltage between P82-1 <=> ground on the OPTFDR Board +24 V?</p> | Go to Step 7. | Go to Step 5. |
| 5 | <p>Check for +24 V to the OPTFDR 1 Board.</p> <ol style="list-style-type: none"> 1. Disconnect P/J83. 2. Close the Interlock Switch while testing. <p>Is the voltage between P83-3 <=> P83-4 on the OPTFDR Board +24 V?</p> | Replace the OPTFDR Board. | Go to Step 6 |
| 6 | <p>Check the Feeder Interface continuity.</p> <ol style="list-style-type: none"> 1. Disconnect P/J171 or P/J172 and P/J83. 2. Check continuity between J171/2 <=> P83 | Go to Step 7. | Replace the OPFREC Harness. |
| 7 | <p>Replace the Drive Assembly.</p> <p>Does the error persist?</p> | Go to Step 8. | Complete |
| 8 | <p>Perform Steps 1 through 3 on page 8-113.</p> <ol style="list-style-type: none"> 1. Open and close the front door. 2. Observe the Turn Roller. <p>Does the Turn Roller turn while the printer is warming up?</p> | Go to Step 13. | Go to Step 9. |
| 9 | <p>Test the Turn Clutch.</p> <ol style="list-style-type: none"> 1. Close the Interlock Switch while testing. 2. Run the Service Diagnostics Turn Clutch test. <p>Does the Tray 3 Turn Clutch function correctly?</p> | Check the Clutch for slipping or the gear for damage. | Go to Step 10. |
| 10 | <p>Check for +24 V to the Turn Clutch.</p> <ol style="list-style-type: none"> 1. Disconnect P/J825 2. Close the Interlock Switch while testing. <p>Is there +24 V across P825-2 <+>ground?</p> | Go to Step 11. | Replace the OPTFDR 1 Board. |
| 11 | <p>Check all pins on the OPFDR Harness PL11.3.24 for continuity.</p> <ol style="list-style-type: none"> 1. Disconnect P/J85 and P/J825. 2. Check continuity between J85 <=> P825. | Go to Step 12. | Replace the OPFDR Harness. |

Troubleshooting Procedure Table (Continued)

| Step | Actions and Questions | Yes | No |
|------|--|---|---|
| 12 | Check Turn Clutch resistance. Disconnect P/J825. Is the resistance between J825-1 <=> J825-2 less than 200Ω? | Go to Step 13. | Replace the Turn Clutch (Part of the Paper Pick Assembly) (page 8-122). |
| 13 | Check the Feed Gear. Does the Feed Gear in the Paper Pick Assembly turn when printing a sheet of paper? | Check the Feed Solenoid for damage. | Go to Step 14. |
| 14 | Test the Feed Solenoid. Run the Service Diagnostics Feed Solenoid test. Does the solenoid function correctly? | Check the feed solenoid stopper and replace if necessary. | Go to Step 15. |
| 15 | Check for +24 V to the Feed Solenoid. 1. Disconnect P/J824 2. Close the Interlock Switch while testing. Is there +24 V across P824-2 <=>ground? | Go to Step 17. | Go to Step 16. |
| 16 | Check all pins on the OPFDR Harness PL11.3.24 for continuity. 1. Disconnect P/J85 and P/J824. 2. Check continuity between J85 <=> P824 | Go to Step 17. | Replace the OPFDR Harness. |
| 17 | Test the Feed Solenoid resistance. Disconnect P/J824. Is J824-1 <=> J824-2 less than 100Ω? | Go to Step 17. | Replace the Feed Solenoid (Part of the Paper Pick Assembly) (page 8-122). |
| 18 | Check all pins on the OPFPLG Harness PL3.2.11 for continuity. 1. Disconnect P/J171 and P/J17. 2. Check continuity between P171 <=> J17. | Replace the Engine Control Board (page 8-104). | Replace the OPFPLG Harness (page 8-26). |

Misfeed at Tray 4: Jam T4

Paper being fed from the 1100-Sheet Feeder did not reach the Registration Sensor on time.

Applicable Status Code:

Code 158: Feed Jam

Initial Actions:

- Try picking paper from a different tray.
- Ensure that Tray 4 is installed properly and the paper guides are set correctly.
- Remove, fan, and reload supported media in Tray 4.
- Remove any obstructions or debris in the paper path and cycle printer power.
- If the problem persists, follow the procedure below.

Troubleshooting Reference Table

| Applicable Parts | Wiring and Plug/Jack References |
|---|---|
| <ul style="list-style-type: none">■ Feed Rollers, PL12.5.18■ Paper Pick Assembly, PL12.5.1■ Drive Assembly, PL12.3.9■ OPFDR Harness, PL12.3.7■ OPTFDR Board, PL12.3.3■ OPFREC2 Harness, PL12.3.1 | <ul style="list-style-type: none">■ 1100-Sheet Feeder P/J Locator (page 10-10)■ 1100-Sheet Feeder Tray Wiring (page 10-31)■ 1100-Sheet Feeder Drive Wiring (page 10-30) |

Troubleshooting Procedure Table

| Step | Actions and Questions | Yes | No |
|------|--|---|--|
| 1 | Check the printer paper path. Does paper feed correctly from Tray 2? | Go to Step 2. | See "Misfeed at Tray 2 Jam T2" on page 3-20. |
| 2 | If possible, print a Test print from Tray 4. Does the Drive Assembly operate? | Go to Step 9. | Go to Step 3. |
| 3 | Test the Drive Assembly. Run the Service Diagnostics HCF/LTA Motor test. Does the Drive Motor function correctly? | Replace the Engine Control Board, page 8-107. | Go to Step 4. |
| 4 | Check for +24 V to the Drive Motor. 1. Disconnect P/J82. 2. Close the Interlock Switch while testing. Is the voltage between P82-1 <=> ground on the Upper Circuit Board HCF +24 V? | Go to Step 7. | Go to Step 5. |

Troubleshooting Procedure Table (Continued)

| Step | Actions and Questions | Yes | No |
|------|---|---|---|
| 5 | Check for +24 V to the OPTFDR Board. 1. Disconnect P/J83. 2. Close the Interlock Switch while testing. Is the voltage between P83-3 <=> P83-4 on the Lower Feeder Circuit Board +24 V? | Replace the Lower Circuit Board HCF. | Go to Step 6 |
| 6 | Check all pins on the OPFREC2 Harness PL12.3.1 for continuity. 1. Disconnect P/J172 and P/J83. 2. Check continuity between J172 <=> P83. | Go to Step 7. | Replace the OPFREC2 Harness. |
| 7 | Replace the Drive Assembly (page 8-121). Does the error persist? | Go to Step 8. | Complete |
| 8 | Perform Steps 1 through 3 on page 8-113. Open and close the front door. Observe the Turn Roller. Does the Turn Roller turn while the printer is warming up? | Go to Step 13. | Go to Step 9. |
| 9 | Test the Turn Clutch. 1. Close the Interlock Switch while testing. 2. Run the Service Diagnostics Turn Clutch test. Does the Tray 4 Turn Clutch function correctly? | Check the Clutch for slipping or the gear for damage. | Go to Step 10. |
| 10 | Check for +24 V to the Turn Clutch. 1. Disconnect P/J825 2. Close the Interlock Switch while testing. Is there +24 V across P85-2 <+>ground? | Go to Step 11. | Replace the Circuit Board HCF. |
| 11 | Check all pins on the OPFDR2 Harness PL12.3.7 for continuity. 1. Disconnect P/J85 and P/J825. 2. Check continuity between J85 <=> P825. | Go to Step 12. | Replace the OPFDR2 Harness. |
| 12 | Check Turn Clutch resistance. Disconnect P/J825. Is the resistance between J825-1 <=> J825-2 less than 200Ω? | Go to Step 13. | Replace the Turn Clutch (Part of the Paper Pick Assembly) (page 8-122). |
| 13 | Check the Feed Gear. Does the Feed Gear in the Paper Pick Assembly turn when printing a sheet of paper? | Check the Feed Solenoid for damage. | Go to Step 14. |
| 14 | Test the Feed Solenoid. Run the Service Diagnostics Feed Solenoid test. Does the solenoid function correctly? | Check the feed solenoid stopper and replace if necessary. | Go to Step 15. |

Troubleshooting Procedure Table (Continued)

| Step | Actions and Questions | Yes | No |
|-----------|--|--|--|
| 15 | Check for +24 V to the Feed Solenoid. 1. Disconnect P/J824 2. Close the Interlock Switch while testing. Is there +24 V across P824-2 <+>ground? | Go to Step 17. | Go to Step 16. |
| 16 | Check all pins on the OPFDR Harness PL12.3.7 for continuity. 1. Disconnect P/J85 and P/J824. 2. Check continuity between J85 <=> P824. | Go to Step 17. | Replace the OPFDR Harness. |
| 17 | Test the Feed Solenoid resistance. Disconnect P/J824. Is J824-1 <=> J824-2 less than 100Ω? | Go to Step 17. | Replace the Feed Solenoid (Part of the Paper Pick Assembly). |
| 18 | Check all pins on the OPFPLG Harness PL3.2.11 for continuity. 1. Disconnect P/J171 and P/J17. 2. Check continuity between P171 <=> J17. | Replace the Engine Control Board (page 8-104). | Replace the OPFPLG Harness (page 8-26). |

Misfeed at Tray 5: Jam T5

Paper being fed from the 1100-Sheet Feeder did not reach the Registration Sensor on time.

Applicable Status Code:

Code 159: Feed Jam

Initial Actions:

- Try picking paper from a different tray.
- Ensure that Tray 5 is installed properly and the paper guides are set correctly.
- Remove, fan, and reload supported media in Tray 5.
- Remove any obstructions or debris in the paper path and cycle printer power.
- If the problem persists, follow the procedure below.

Troubleshooting Reference Table

| Applicable Parts | Wiring and Plug/Jack References |
|--|---|
| <ul style="list-style-type: none">■ Feed Rollers, PL12.5.18■ Paper Pick Assembly, PL12.5.1■ Drive Assembly, PL12.3.9■ OPFDR2 Harness, PL12.3.7■ OPTFDR Board, PL12.3.3■ OPFREC2 Harness, PL12.3.1 | <ul style="list-style-type: none">■ 1100-Sheet Feeder P/J Locator (page 10-10)■ 1100-Sheet Feeder Drive Wiring (page 10-30)■ 1100-Sheet Feeder Lower Tray Wiring (page 10-32) |

Troubleshooting Procedure Table

| Step | Actions and Questions | Yes | No |
|------|--|--|--|
| 1 | Check the printer paper path. Does paper feed correctly from Tray 2? | Go to Step 2. | See "Misfeed at Tray 2 Jam T2" on page 3-20. |
| 2 | If possible, print a Test print from Tray 5. Does the Drive Assembly operate? | Go to Step 9. | Go to Step 3. |
| 3 | Test the Drive Assembly. Run the Service Diagnostics HCF/LTA Motor test. Does the Drive Motor function correctly? | Replace the Engine Control Board, page 8-107. | Go to Step 4. |
| 4 | Check for +24 V to the Drive Motor. 1. Disconnect P/J82. 2. Close the Interlock Switch while testing. Is the voltage between P82-1 <=> ground on the Upper Circuit Board HCF +24 V? | Go to Step 7. | Go to Step 5. |

Troubleshooting Procedure Table (Continued)

| Step | Actions and Questions | Yes | No |
|------|---|---|---|
| 5 | <p>Check for +24 V to the OPTFDR Board.</p> <ol style="list-style-type: none"> 1. Disconnect P/J83. 2. Close the Interlock Switch while testing. <p>Is the voltage between P83-3 <=> P83-4 on the Lower Feeder Circuit Board +24 V?</p> | Replace the Lower Circuit Board HCF. | Go to Step 6 |
| 6 | <p>Check all pins on the OPFREC2 Harness PL12.3.1 for continuity.</p> <ol style="list-style-type: none"> 1. Disconnect P/J172 and P/J83. 2. Check continuity between J172 <=> P83. | Go to Step 7. | Replace the OPFREC2 Harness. |
| 7 | <p>Replace the Drive Assembly (page 8-121).</p> <p>Does the error persist?</p> | Go to Step 8. | Complete |
| 8 | <p>Check the Turn Roller.</p> <ol style="list-style-type: none"> 1. Perform Steps 1 through 3 on page 8-113. Open and close the front door. 2. Observe the Turn Roller. <p>Does the Turn Roller turn while the printer is warming up?</p> | Go to Step 13. | Go to Step 9. |
| 9 | <p>Test the Turn Clutch.</p> <ol style="list-style-type: none"> 1. Close the Interlock Switch while testing. 2. Run the Service Diagnostics Turn Clutch test. <p>Does the Tray 4 Turn Clutch function correctly?</p> | Check the Clutch for slipping or the gear for damage. | Go to Step 10. |
| 10 | <p>Check for +24 V to the Turn Clutch.</p> <ol style="list-style-type: none"> 1. Disconnect P/J825 2. Close the Interlock Switch while testing. <p>Is there +24 V across P85-2 <+>ground?</p> | Go to Step 11. | Replace the Circuit Board HCF. |
| 11 | <p>Check all pins on the OPFDR2 Harness PL12.3.7 for continuity.</p> <ol style="list-style-type: none"> 1. Disconnect P/J85 and P/J825. 2. Check continuity between J85 <=> P825. | Go to Step 12. | Replace the OPFDR2 Harness. |
| 12 | <p>Check Turn Clutch resistance.</p> <p>Disconnect P/J825.</p> <p>Is the resistance between J825-1 <=> J825-2 less than 200Ω?</p> | Go to Step 13. | Replace the Turn Clutch (Part of the Paper Pick Assembly) (page 8-125). |
| 13 | <p>Check the Feed Gear.</p> <p>Does the Feed Gear in the Paper Pick Assembly turn when printing a sheet of paper?</p> | Check the Feed Solenoid for damage. | Go to Step 14. |
| 14 | <p>Test the Feed Solenoid.</p> <p>Run the Service Diagnostics Feed Solenoid test.</p> <p>Does the solenoid function correctly?</p> | Check the feed solenoid stopper and replace if necessary. | Go to Step 15. |

Troubleshooting Procedure Table (Continued)

| Step | Actions and Questions | Yes | No |
|------|--|--|--|
| 15 | Check for +24 V to the Feed Solenoid. 1. Disconnect P/J824 2. Close the Interlock Switch while testing. Is there +24 V across P824-2 <+>ground? | Go to Step 17. | Go to Step 16. |
| 16 | Check all pins on the OPFDR Harness PL11.3.24 for continuity. 1. Disconnect P/J85 and P/J824. 2. Check continuity between J85 <=> P824. | Go to Step 17. | Replace the OPFDR Harness. |
| 17 | Test the Feed Solenoid resistance. Disconnect P/J824. Is J824-1 <=> J824-2 less than 100Ω? | Go to Step 17. | Replace the Feed Solenoid (Part of the Paper Pick Assembly). |
| 18 | Check all pins on the OPFPLG Harness PL3.2.11 for continuity. 1. Disconnect P/J171 and P/J17. 2. Check continuity between P171 <=> J17. | Replace the Engine Control Board (page 8-104). | Replace the OPFPLG Harness (page 8-26). |

Door and Cover Error Procedures

Close Front Door

The Interlock Switch indicates that Door A or B is open.

Applicable Status Code:

Code 150: Front Door is open

Initial Actions:

- Ensure that the doors are free of obstructions and fully closed.
- Verify that the Interlock Switch Actuator is not broken.
- Cycle printer power.
- If the problem persists, follow the procedure below.

Troubleshooting Reference Table

| Applicable Parts | Wiring and Plug/Jack References |
|---|--|
| <ul style="list-style-type: none"> ■ Front Cover, PL1.1.6 ■ Interlock Switch, PL9.1.11 ■ LVPS, PL9.1.6 ■ LV Harness, PL10.1.2 | <ul style="list-style-type: none"> ■ Print Engine Map 2 - P/J Locator (page 10-6) ■ Print Engine Power Wiring (page 10-17) |

Troubleshooting Procedure Table

| Step | Actions and Questions | Yes | No |
|------|--|--|--|
| 1 | Check the following for evidence of fault or damage: <ul style="list-style-type: none"> ■ Front Cover, PL1.1.6 ■ Interlock Switch, PL9.1.11 | Replace any damaged parts. | Go to Step 2. |
| 2 | Test the Interlock Switch. Run the Service Diagnostics Interlock Switch test. Does the switch function correctly? | Replace the Engine Control Board (page 8-104). | Go to Step 3. |
| 3 | Check the Interlock Switch for +5 V. 1. Close the Interlock Switch while testing. 2. Disconnect P/J161 and P/J163. Does P/J161-1 <=> P/J163-2 = +5 V? Does P/J161-3 <=> P/J163-2 = +5 V? | Go to Step 4 | Replace the Interlock Switch (page 8-101). |
| 4 | Check the Interlock open signal. Disconnect P/J61. Does J61-8 <=> J61-16 = 0 V? | Replace the Engine Control Board (page 8-104). | Go to Step 5. |
| 5 | Check the LVPS. Disconnect P/J165. Does J165-11 <=> J165-3 = 0 V? | Replace the LV Harness. | Replace the LVPS |

Consumable/Routine Maintenance Procedures

Install or Reseat Imaging Unit

The Imaging Unit CRUM fails to detect the Imaging Unit.

Applicable Status Code:

Code 212: Install or Reseat Imaging Unit

Initial Actions:

- Remove and reseat the Imaging Unit.
- Ensure that Door C is fully closed.
- Cycle printer power.
- If the problem persists, follow the procedure below

Troubleshooting Reference Table

| Applicable Parts | Wiring and Plug/Jack References |
|---|--|
| <ul style="list-style-type: none">■ Imaging Unit, PL6.1.1■ CRUM Connector, PL7.1.4■ PHD2 Harness, PL7.1.7■ FAN/PHD/MOT Harness, PL10.1.9 | <ul style="list-style-type: none">■ Print Engine Map 2 - P/J Locator (page 10-6)■ Print Engine Laser Unit Wiring (page 10-23) |

Troubleshooting Procedure Table

| Step | Actions and Questions | Yes | No |
|------|---|--|-----------------------|
| 1 | Remove the Imaging Unit. Inspect the printer cavity for damage, debris, and toner under the auger area preventing the Imaging Unit from being seated properly. Is there foreign material or damage? | Remove foreign material. Vacuum out loose toner if found. | Go to Step 2. |
| 2 | Inspect and reseat the Imaging Unit. Does the error persist?. | Go to Step 3. | Complete |
| 3 | Check Imaging Unit CRUM connection. Are P/J710 and P/J484 connected? | Go to Step 4. | Reconnect the CRUM. |
| 4 | Check all pins on the PHD2 Harness PL7.1.7 for continuity. 1. Disconnect P/J710 and P/J484. 2. Check continuity between J484<=>J710. | Go to Step 5 | Replace PHD2 Harness. |

Troubleshooting Procedure Table (Continued)

| Step | Actions and Questions | Yes | No |
|------|--|--|---------------------------------|
| 5 | Check all pins on the FAN/PHD/MOT Harness PL10.1.9 for continuity. 1. Disconnect P/J484 and P/J48. 2. Check continuity between J48 <=> P484. | Go to Step 6 | Replace the FAN/PHD/MOT Harness |
| 6 | Replace the Imaging Unit. Does the error persist? | Replace the Engine Control Board (page 8-104). | Complete |

Replace Imaging Unit or Imaging Unit Is Near End of Life

The Imaging Unit Life counter indicates the Imaging Unit is near or has reached its end of life.

Applicable Status Code:

Code 196: Replace Imaging Unit

Warning: Imaging Unit Near End of Life

Initial Actions:

- Print the Supplies Usage page and verify life remaining and date Imaging Unit was installed.
- Cycle printer power.
- If the problem persists, follow the procedure below

Note

The “Imaging Unit is Near End of Life” is a warning. “Replace Imaging Unit” is a hard stop.

Troubleshooting Reference Table

| Applicable Parts | Wiring and Plug/Jack References |
|---|--|
| <ul style="list-style-type: none">■ Imaging Unit, PL6.1.1■ CRUM Connector, PL7.1.4■ PHD2 Harness, PL7.1.7■ FAN/PHD/MOT Harness, PL10.1.9 | <ul style="list-style-type: none">■ Print Engine Map 2 - P/J Locator (page 10-6)■ Print Engine Laser Unit Wiring (page 10-23) |

Troubleshooting Procedure Table

| Step | Actions and Questions | Yes | No |
|------|--|--|---------------------------------|
| 1 | Check the following for evidence of fault or damage: <ul style="list-style-type: none"> ■ Imaging Unit PL6.1.1 ■ CRUM Connector PL7.1.4 Is there any damage? | Replace any damaged parts. | Go to Step 2. |
| 2 | Replace the Imaging Unit. Does the error persist? | Go to Step 3. | Complete |
| 3 | Check Imaging Unit CRUM connection. Are P/J710 and P/J484 connected? | Go to Step 4. | Reconnect the CRUM Connector. |
| 4 | Check all pins on the PHD2 Harness PL7.1.7 for continuity. <ol style="list-style-type: none"> 1. Disconnect P/J710 and P/J484. 2. Check continuity between J484<=>J710 | Go to Step 5. | Replace the PHD2 Harness. |
| 5 | Check all pins on the FAN/PHD/MOT Harness for continuity. <ol style="list-style-type: none"> 1. Disconnect P/J484 and P/J48. 2. Check continuity between J48 <=> P484 | Replace the Engine Control Board (page 8-104). | Replace the FAN/PHD/MOT Harness |

Install or Reseat Transfer Roller

The printer does not detect the presence of the Transfer Roller.

Applicable Status Code:

Code 213: Install or Reseat Transfer Roller

Initial Actions:

- Ensure the CTD (ADC) Sensor is clean and the Transfer Roller is installed correctly.
- Cycle printer power.
- If the problem persists, follow the procedure below.

Troubleshooting Reference Table

| Applicable Parts | Wiring and Plug/Jack References |
|---|---|
| <ul style="list-style-type: none"> ■ CTD (ADC) Sensor, PL5.2.19 ■ Transfer Roller, PL5.1.4 ■ FSR/ADC Harness, PL5.2.28 | <ul style="list-style-type: none"> ■ Print Engine Map 2 - P/J Locator (page 10-6) ■ Print Engine Wiring Xerographics (1/2) (page 10-24) |

Troubleshooting Procedure Table

| Step | Actions and Questions | Yes | No |
|------|---|---|--|
| 1 | Check the following for evidence of fault or damage: <ul style="list-style-type: none"> ■ Transfer Roller PL5.1.4 ■ CTD (ADC) Sensor PL5.2.19 Is there any damage? | Replace any damaged parts. | Go to Step 2. |
| 2 | Clean the CTD (ADC) Sensor. Does this fix the problem? | Complete | Go to Step 3. |
| 3 | Test the CTD (ADC) Sensor. Run the Service Diagnostics CTD (ADC) Sensor test. Does the sensor function correctly? | Go to Step 4. | Go to Step 5. |
| 4 | Replace the Transfer Roller. Does the error persist? | Go to Step 5. | Complete |
| 5 | Check the CTD (ADC) Sensor connection. Is P/J136 connected to the harness? | Go to Step 6. | Connect the sensor. |
| 6 | Check all pins on the FSR/ADC Harness PL5.2.28 for continuity. 1. Disconnect P/J36 and P/J136. 2. Check continuity between J36 <=> J136. | Go to Step 7. | Replace the FSR/ADC Harness. |
| 7 | Check the CTD (ADC) Sensor signal. Disconnect P/J36. Does J36-2 <=> J36-5 = 0 V? | Replace the CTD (ADC) Sensor (page 8-71). | Replace the Engine Control Board (page 8-104). |

Replace Transfer Roller or Transfer Roller Is at End of Life

The Toner Full Sensor indicates that the Transfer Roller requires replacement.

Applicable Status Code:

Code 206: Replace Transfer Roller

Warning: Transfer Roller is at End of Life

Initial Actions:

- Print the Supplies Usage page to verify the remaining life and Transfer Roller install date.
- Cycle printer power.
- If the problem persists, follow the procedure below.

Note

Look at the clear plastic window on the Transfer Roller. If toner is present in the center of the window, the Transfer Roller is at end of life and needs to be replaced. If no toner is visible, try cleaning the CTD (ADC) Sensor.

The Transfer Roller is at End of Life is a warning. Replace Transfer Roller is a hard stop.

Troubleshooting Reference Table

| Applicable Parts | Wiring and Plug/Jack References |
|--|--|
| <ul style="list-style-type: none">■ Toner Full Sensor, PL5.2.20■ Transfer Roller, PL5.1.4■ TNRFULL/FSR Harness, PL5.2.30 | <ul style="list-style-type: none">■ Print Engine Map 2 - P/J Locator (page 10-6)■ Print Engine Wiring Xerographics (1/2) (page 10-24) |

Troubleshooting Procedure Table

| Step | Actions and Questions | Yes | No |
|------|---|----------------------------|---------------|
| 1 | Check the following for evidence of fault or damage: <ul style="list-style-type: none">■ Transfer Roller PL5.1.4■ Toner Full Sensor PL5.2.20 | Replace any damaged parts. | Go to Step 2. |

Troubleshooting Procedure Table (Continued)

| Step | Actions and Questions | Yes | No |
|------|--|--|---------------------------------|
| 2 | Test the Toner Full Sensor. Run the Service Diagnostics Transfer Roller Toner Full Sensor test. Does the sensor function correctly? | Go to Step 5 | Go to Step 3. |
| 3 | Check the Toner Full Sensor signal. 1. Remove the Transfer Roller Assembly. 2. Disconnect P/J142. Does the voltage between J142-2 <=> J142-3 = 0 V? | Go to Step 5. | Go to Step 4. |
| 4 | Check all pins on the TNRFULL/FSR Harness PL5.2.30 for continuity. 1. Disconnect P/J52 and P/J142. 2. Check continuity between J52 <=> J142. | Replace Sensor Toner Full. | Replace Toner Full/FSR Harness. |
| 5 | Replace the Transfer Roller. Does the error persist? | Replace the Engine Control Board (page 8-104). | Complete |

Install or Reseat Fuser

The printer does not detect the presence of the Fuser.

Applicable Status Code:

Code 214: Install or Reseat Fuser

Initial Actions:

- Ensure that the Fuser latches are fully latched and cycle printer power.
- If the problem persists, follow the procedure below.

Troubleshooting Reference Table

| Applicable Parts | Wiring and Plug/Jack References |
|--|--|
| <ul style="list-style-type: none"> ■ Fuser, PL5.1.1 ■ FSR/ADC Harness PL5.2.28 | <ul style="list-style-type: none"> ■ Print Engine Map 2 - P/J Locator (page 10-6) ■ Print Engine Wiring Fuser (page 10-22) |

Warning

To avoid the potential of electric shock, ensure the power to the printer is off and the power cord is disconnected from the wall outlet prior to performing Step 2 of the following troubleshooting procedure.

Caution

Allow adequate time for the Fuser to cool before servicing the printer.

Troubleshooting Procedure Table

| Step | Actions and Questions | Yes | No |
|------|--|--|--------------------------------------|
| 1 | Cycle power to the printer. Does the error persist? | Go to Step 2. | Complete |
| 2 | Check the Fuser for damage. Is the Fuser damaged? | Replace the Fuser, then cycle power. | Go to Step 3. |
| 3 | Check Fuser resistance. 1. Remove the Fuser. 2. Disconnect J361. 3. Is the resistance between P361-B5 <=> P361-B4 less than 400K Ω ? 4. Is the resistance between P361-B5 <=> P361-B4 less than 7M Ω ? | Go to Step 4. | Replace the Fuser (page 8-67). |
| 4 | Check all pins on the FSR/ADC Harness PL5.2.28 for continuity. 1. Disconnect P/J36 and J361. 2. Check continuity between J36 <=> J361. | Replace the Engine Control Board (page 8-104). | Replace the FSR/ADC Harness. |

Replace Fuser

The Fuser Life counter indicates that the Fuser has reached its end of life. Fuser replacement is necessary to avoid print quality problems.

Note

There is no hard stop associated with the Replace Fuser message.

Applicable Status Code:

Code 207: Replace Fuser

Initial Actions:

- Print the Supplies Usage page to verify remaining life and Fuser install date.
- Cycle printer power.
- If the problem persists, follow the procedure below.

Troubleshooting Reference Table

| Applicable Parts | Wiring and Plug/Jack References |
|---|---|
| <ul style="list-style-type: none"> ■ Fuser, PL5.1.1 ■ FSR/ADC Harness PL5.2.28 ■ EEPROM Board, PL 9.1.12 ■ EEPROM Harness, PL10.1.8 | <ul style="list-style-type: none"> ■ Print Engine Map 2 - P/J Locator (page 10-6) ■ Print Engine Map 3 - P/J Locator (page 10-7) ■ Print Engine Fuser Wiring (page 10-22) ■ Print Engine Xerographics (1/2) Wiring (page 10-24) |

Warning

Avoid the potential of electric shock by removing the power cord from the wall outlet prior to performing the following procedure.

Caution

Allow adequate time for the Fuser to cool before servicing the printer.

Troubleshooting Procedure Table

| Step | Actions and Questions | Yes | No |
|------|---|--|------------------------------|
| 1 | Check the Fuser connector for damage. | Re-establish proper connection or replace the parts concerned. Power cycle the printer. | Go to Step 2. |
| 2 | Replace the Fuser. Does the error persist? | Go to Step 3. | Complete |
| 3 | Replace the EEPROM Board (page 8-103) Does the error persist? | Go to Step 4. | Complete |
| 4 | Check all pins on the EEPROM Harness PL10.1.8 for continuity. 1. Disconnect P/J191 and P/J144. 2. Check continuity between J191<=>J144. | Go to Step 5. | Replace the EEPROM Harness. |
| 5 | Check all pins on the FSR/ADC Harness PL5.2.28 for continuity. 1. Disconnect P/J36 and J361. 2. Check continuity between J36 <=> J361. | Replace the Engine Control Board (page 8-104). | Replace the FSR/ADC Harness. |

Install or Lock [Y] [M] [C] [K] Toner Cartridge

The printer does not detect the presence of one of the Toner Cartridges.

Applicable Status Codes:

Code 208: Install or Lock Cyan Toner Cartridge

Code 209: Install or Lock Magenta Toner Cartridge

Code 210: Install or Lock Yellow Toner Cartridge

Code 211: Install or Lock Black Toner Cartridge

Initial Actions:

- Ensure that the Toner Cartridges are fully seated and locked into position.
- Ensure that all ribbon tape is removed from the cartridges
- Cycle printer power.
- If the problem persists, follow the procedure below.

Note

Use the steps as appropriate for the color indicated in the error message.

Troubleshooting Reference Table

| Applicable Parts | Wiring and Plug/Jack References |
|---|---|
| <ul style="list-style-type: none">■ Toner Present Switch Bracket, PL7.2.6■ Toner Present Actuator, PL7.2.7■ TNR Harness, PL7.2.18■ CRUM Reader, PL7.2.12 | <ul style="list-style-type: none">■ Print Engine Map 1 - P/J Locator (page 10-5)■ Print Engine Map 3- P/J Locator (page 10-7)■ Print Engine Developer (1/2) Wiring (page 10-20) |

Troubleshooting Procedure Table

| Step | Actions and Questions | Yes | No |
|------|--|--|---------------|
| 1 | Test the Toner Cartridge Sensor. Run the Service Diagnostics Toner Cartridge present test. Does the Toner Cartridge Switch function normally? | Replace the Engine Control Board (page 8-104). | Go to Step 2. |
| 2 | For the problem color, are any of the following parts damaged? <ul style="list-style-type: none">■ Toner Cartridge■ Toner Present Switch Bracket PL7.2.6■ Toner Present Switch Actuator PL7.2.7■ Toner Cartridge Switch Connector | Replace any damaged parts. | Go to Step 3. |

Troubleshooting Procedure Table (Continued)

| Step | Actions and Questions | Yes | No |
|------|---|--|--|
| 3 | Check the Toner Present signal. Disconnect P/J342. Does P342-5 <=> P342-4 [Y], 3 [M], 2 [C], 1 [K] read 0 V? | Go to Step 5. | Go to Step 4. |
| 4 | Check the Toner Present Switch continuity. Depress each switch to test, Is P342-5 <=> P342-4 [Y], 3 [M], 2 [C], 1 [K]? | Go to Step 5. | Replace the CRUM Reader (page 8-93). |
| 5 | Check all pins on the TNR Harness PL7.2.18 for continuity. 1. Disconnect P/J51 and P/J342. 2. Check continuity between J51<=>J342. | Replace the Engine Control Board (page 8-104). | Replace the TNR Harness. |

Replace [Y] [M] [C] [K] Toner Cartridge or [Y] [M] [C] [K] Toner Is Low

An empty cartridge (Code 202~205), a metered cartridge installed in a non-metered printer, an unsupported high-capacity cartridge (Code 224~227), or a fatal error within the cartridge or printer can cause this error condition. Check for an error code in the help text prior to troubleshooting this error message. For codes 90~99, a different troubleshooting procedure is provided on (page 3-48).

When no jobs are being sent to the printer, the [Y] [M] [C] [K] Toner Cartridge Empty message displays on the Control Panel. This warning allows continued printing in black and white (Run Black) mode for a short period of time. Once the color cartridges are empty, the message changes to Replace [Y] [M] [C] [K] Toner Cartridge, and the printer enters a hard stop condition.

Note

[Y] [M] [C] [K] Toner Is Low is a warning condition. Replace [Y] [M] [C] [K] Toner Cartridge is an error condition.

Applicable Status Codes:

Code 202, 224: Replace Cyan Toner Cartridge
Code 203, 225: Replace Magenta Toner Cartridge
Code 204, 226: Replace Yellow Toner Cartridge
Code 205, 227: Replace Black Toner Cartridge

Warning: Cyan Toner Cartridge is Low
Warning: Magenta Toner Cartridge is Low
Warning: Yellow Toner Cartridge is Low
Warning: Black Toner Cartridge is Low

Initial Actions:

- Print the Supplies Usage page to verify remaining cartridge life and install date.
- Replace the affected cartridge and cycle printer power.
- If the problem persists, follow the procedure below.

Troubleshooting Reference Table

| Applicable Parts | Wiring and Plug/Jack References |
|--|--|
| <ul style="list-style-type: none"> ■ No Toner Sensor, PL7.2.5 ■ Toner Cartridge Holder, PL7.2.1 ■ TNR Harness, PL7.2.18 | <ul style="list-style-type: none"> ■ Print Engine Map 1 - P/J Locator (page 10-5) ■ Print Engine Developer (1/2) Wiring (page 10-20) |

Troubleshooting Procedure Table

| Step | Actions and Questions | Yes | No |
|------|---|---|--|
| 1 | Replace the affected Toner Cartridge. Does the error persist? | Go to Step 2. | Complete |
| 2 | Check the No Toner Sensor signals. Disconnect P/J51. Is the signal less than +0.2 V for the affected sensor? J51-A8 <=> J51-A7 Yellow J51-A5 <=> J51-A4 Magenta J51-A2 <=> J51-A1 Cyan J51-A11 <=> J51-A10 Black | Go to Step 5 | Go to Step 3 |
| 3 | Check the TNR Harness sensor connections J701 (Y), J702 (M), J703 (C), J704 (K) <=> J51 for continuity. | Go to Step 4 | Replace the TNR Harness. |
| 4 | Test the No Toner Sensor. Run the Service Diagnostics Toner Low/Empty test on the affected cartridge. If the test fails, check the sensor connector, if the connector is ok, replace the Toner Sensor. Does the error persist? | Go to Step 5. | Complete |
| 5 | Test the Toner Motor. 1. Close the Interlock Switch while testing. NOTE: Run this test for ONLY 5 seconds to avoid packing the toner. 2. Run the Service Diagnostics Toner Motor test for the affected cartridge. Does the Toner Motor function correctly? | Check the toner stirring auger or gear for damage. Replace if necessary. | Go to Step 6. |
| 6 | Is the auger tube of the problem color full of toner near the hopper end? | Go to Step 7. | Inspect the toner cartridge for dispense problems. |

Troubleshooting Procedure Table (Continued)

| Step | Actions and Questions | Yes | No |
|------|---|--|--|
| 7 | Check the Engine Control Board. Disconnect P/J51. 1. Close the Interlock Switch while testing. 2. Is there +24 V for the Toner Motor? P51-B21 <=> ground Yellow P51-B26 <=> ground Magenta P51-B31 <=> ground Cyan J51-B36 <=> ground Black Is there +24 V to the affected Toner Motor? | Go to Step 8. | Replace the Engine Control Board (page 8-104). |
| 8 | Check the TNR Harness Toner Motor connections for continuity. Disconnect P/J51 and P511 (Y), P512 (M), P513 (C), 514 (K). Is the harness conductive? | Go to Step 9 | Replace the Toner Harness. |
| 9 | Replace the Toner Cartridge Holder for the affected color. Does the error persist? | Replace the Engine Control Board (page 8-104). | Complete |

Dusty Density Sensor

The printer detects an accumulation of dust on the CTD (ADC) Sensor.

Applicable Status Code:

Code 151: Dusty Density Sensor

Initial Actions:

- Cycle printer power.
- If the problem persists, follow the procedure below

Troubleshooting Reference Table

| Applicable Parts | Wiring and Plug/Jack References |
|---|---|
| <ul style="list-style-type: none"> ■ CTD (ADC) Sensor, PL5.2.19 ■ FSR/ADC Harness, PL5.2.28 | <ul style="list-style-type: none"> ■ Print Engine Map 2 - P/J Locator (page 10-6) ■ Print Engine Xerographics (1/2) Wiring (page 10-24) |

Troubleshooting Procedure Table

| Step | Actions and Questions | Yes | No |
|------|--|---------------|----------|
| 1 | Clean the CTD (ADC) Sensor. Does the error persist? | Go to Step 2. | Complete |

Troubleshooting Procedure Table (Continued)

| Step | Actions and Questions | Yes | No |
|------|---|---|--|
| 2 | Check the following for evidence of fault or damage: <ul style="list-style-type: none"> ■ Transfer Roller Assembly, PL5.1.4 ■ CTD (ADC) Sensor, PL5.2.19 | Replace the damaged parts. | Go to Step 3. |
| 3 | Check the CTD (ADC) Sensor connection. Is P/J136 connected to the harness? | Go to Step 4. | Reconnect the sensor. |
| 4 | Replace the CTD (ADC) Sensor (page 8-71). Does the error persist? | Go to Step 5. | Complete. |
| 5 | Check all pins on the FSR/ADC Harness PL5.2.28 for continuity. <ol style="list-style-type: none"> 1. Disconnect P/J36 and P/J136. 2. Check continuity between J36 <=> J136. | Go to Step 6. | Replace the FSR/ADC Harness. |
| 6 | Check the CTD (ADC) Sensor signal. Disconnect P/J136. Does P136-4 <=> P136-1 = 0 V? | Replace the CTD (ADC) Sensor (page 8-71). | Replace the Engine Control Board (page 8-104). |

Remove Ribbon from [Y] [M] [C] [K] Toner Cartridge

The printer detected that one of the Toner Cartridge ribbons has not been removed.

Applicable Status Codes:

Code 215: Remove Ribbon from Cyan Toner Cartridge

Code 216: Remove Ribbon from Magenta Toner Cartridge

Code 217: Remove Ribbon from Yellow Toner Cartridge

Code 218: Remove Ribbon from Black Toner Cartridge

Initial Actions:

- Remove the Toner Cartridge and ensure that the ribbon tape has been completely removed.
- Inspect the mouth of the toner auger for obstructions or debris.
- Cycle printer power.
- If the problem persists, follow the procedure below.

Troubleshooting Reference Table

| Applicable Parts | Wiring and Plug/Jack References |
|---|---------------------------------|
| ■ Pertinent toner cartridge, PL7.2.8~11 | |

Troubleshooting Procedure Table

| Step | Actions and Questions | Yes | No |
|------|---|---------------|--|
| 1 | Has the shipping ribbon been completely removed from the Toner Cartridge? | Go to Step 2. | Remove the ribbon and cycle printer power. |
| 2 | Does the error clear after Door A is opened and closed? | Complete | Refer to "Install or Lock [Y] [M] [C] [K] Toner Cartridge" on (page 3-41). |

Tray 2 Paper Is Low

The tray's Low Paper Sensor indicates a Low Paper condition.

Applicable Status Code:

Warning: Tray 2 is Low

Initial Actions:

- Check that Tray 2 is at least half full of paper and free of obstructions.
- Insert the tray and cycle printer power.
- If the problem persists, follow the procedure below.

Troubleshooting Reference Table

| Applicable Parts | Wiring and Plug/Jack References |
|---|---|
| <ul style="list-style-type: none"> ■ Low Paper Sensor, PL3.3.7 ■ Low Paper Sensor Actuator, PL3.3.14 ■ FDR Harness, PL3.3.22 | <ul style="list-style-type: none"> ■ Print Engine Map 4 - P/J Locator (page 10-8) ■ Print Engine Tray 2 Wiring (page 10-18) |

Troubleshooting Procedure Table

| Step | Actions and Questions | Yes | No |
|------|---|----------------------------|---------------|
| 1 | Fill the tray with paper. Does the error occur if the tray is full? | Go to Step 2. | Complete |
| 2 | Check the following for evidence of fault or damage: <ul style="list-style-type: none"> ■ Low Paper Sensor, PL3.3.7 ■ Low Paper Actuator, PL3.3.14 Is there any damage? | Replace any damaged parts. | Go to Step 3. |

Troubleshooting Procedure Table (Continued)

| Step | Actions and Questions | Yes | No |
|------|--|--|--------------------------|
| 3 | Test the Low Paper Sensor. Run the Service Diagnostics Tray 2 Low Paper Sensor test. Does the sensor and actuator function properly? | Replace the Engine Control Board (page 8-104). | Go to Step 4. |
| 4 | Check the Low Paper Sensor signal. Is there +3.3 V between J473-1 <=> J473-2? | Replace the Low Paper Sensor (page 8-29). | Go to Step 5. |
| 5 | Check all pins on the FDR Harness PL3.3.22 for continuity. 1. Disconnect P/J47 and P/J471. 2. Check continuity between J47 <=> J471. | Replace the Engine Control Board (page 8-104). | Replace the FDR Harness. |

Tray [3] [4] [5] Paper Is Low

An optional tray's Low Paper Sensor indicates a Low Paper condition.

Applicable Status Codes:

Warning: Tray 3 is Low

Warning: Tray 4 is Low

Warning: Tray 5 is Low

Initial Actions:

- Check that Tray 2 is at least half full of paper and free of obstructions.
- Insert the tray and cycle printer power.
- If the problem persists, follow the procedure below.

Troubleshooting Reference Table

| Applicable Parts | Wiring and Plug/Jack References |
|--|--|
| For 550-Sheet Feeder: <ul style="list-style-type: none"> ■ Low Paper Sensor, PL11.3.7 ■ Low Paper Actuator, PL11.3.16 ■ OPTFDR Board, PL11.1.10 ■ LOWP Harness, PL11.3.25 | <ul style="list-style-type: none"> ■ 550-Sheet Feeder P/J Locator (page 10-12) ■ 550-Sheet Feeder Tray Wiring (page 10-35) ■ 1100-Sheet Feeder P/J Locator (page 10-10) ■ 1100-Sheet Feeder Tray Wiring (page 10-31) |
| For 1100-Sheet Feeder: <ul style="list-style-type: none"> ■ Low Paper Sensor, PL12.4.7 ■ Low Paper Actuator, PL12.4.15 ■ OPTFDR Board, PL12.3.3 ■ LOWP Harness, PL12.3.6 | |

Troubleshooting Procedure Table

| Step | Actions and Questions | Yes | No |
|------|--|---|---------------------------|
| 1 | Fill the tray with paper. Does the error occur if the tray is full? | Go to Step 2. | Complete |
| 2 | Check the following for evidence of fault or damage: <ul style="list-style-type: none"> ■ Low Paper Sensor ■ Low Paper Actuator Is there any damage? | Replace any damaged parts. | Go to Step 3. |
| 3 | Test the Low Paper Sensor. Run the Service Diagnostics Low Paper Sensor test. Does the sensor function properly? | Replace the Engine Control Board (page 8-104). | Go to Step 4. |
| 4 | Check the Low Paper Sensor signal. Is there +3.3 V between J823-1 <=> J473-2? | Replace the Low Paper Sensor for the affected tray. | Go to Step 5. |
| 5 | Check all pins on the LOWP Harness PL12.3.6 for continuity. <ol style="list-style-type: none"> 1. Disconnect P/J81 and P/J823. 2. Check continuity between J81 <=> J471. | Replace the OPTFDR Board for the affected tray. | Replace the LOWP Harness. |

Replace [Y] [M] [C] [K] Toner Cartridge

The CRUM Reader detected a CRUM ID error or a Non-Xerox Toner Cartridge.

An empty or non-genuine Xerox cartridge, a fatal cartridge error, or a fatal printer error can cause this error. Check for an error code in the help text prior to troubleshooting. If a code in the range of 232~235 appears, or no code is present, see "Replace [Y] [M] [C] [K] Toner Cartridge or [Y] [M] [C] [K] Toner Is Low" on page 3-42.

A Non-Xerox Toner Cartridge warning message occurs when the printer detects the presence of Non-Xerox Toner. The customer can continue to print by selecting use it on the Control Panel when queried whether to use the Non-Xerox cartridge. If the customer chooses Do Not Use, the warning message is replaced by the Replace [C] [M] [Y] [K] Toner Cartridge error message and the associate codes (96 ~ 99) appear in the help text.

Applicable Status Codes:

Code 90: Cyan CRUM ID Error

Code 91: Magenta CRUM ID Error

Code 92: Yellow CRUM ID Error

Code 93: Black CRUM ID Error

Code 96: Non-Xerox Cyan Toner Cartridge Detected

Code 97: Non-Xerox Magenta Toner Cartridge Detected

Code 98: Non-Xerox Yellow Toner Cartridge Detected

Code 99: Non-Xerox Black Toner Cartridge Detected

Initial Actions:

- Ensure that the Toner Cartridges are fully seated and locked into position.
- Cycle printer power.
- If the problem persists, follow the procedure below.

Troubleshooting Reference Table

| Applicable Parts | Wiring and Plug/Jack References |
|---|---|
| <ul style="list-style-type: none">■ Toner Cartridge, PL7.2.8■ RFID Harness, PL7.2.17■ RFID2 Harness, PL7.2.16■ CRUM Reader, PL7.2.12 | <ul style="list-style-type: none">■ Print Engine Map 1 - P/J Locator (page 10-5)■ Print Engine Developer (1/2) Wiring (page 10-20) |

Troubleshooting Procedure Table

| Step | Actions and Questions | Yes | No |
|------|---|---------------|---------------------------------|
| 1 | Check Toner Cartridge installation. Are the Toner Cartridges properly installed? | Go to Step 2. | Correct the installation. |
| 2 | Replace the affected Toner Cartridge. Does the error persist after a genuine Xerox Toner Cartridge is installed? | Go to Step 3. | Complete |
| 3 | Check the CRUM Reader Board connection. Is P/J341 connected to the harness? | Go to Step 4. | Reconnect the CRUM Reader Board |
| 4 | Replace the CRUM Reader Board. Does the error persist? | Go to Step 5. | Complete |

Troubleshooting Procedure Table (Continued)

| Step | Actions and Questions | Yes | No |
|------|--|--|----------------------------|
| 5 | Check all pins on the RFID2 Harness PL7.2.16 for continuity. 1. Disconnect P/J341 and P/J3411. 2. Check continuity between J341<=>J3411. | Go to Step 6. | Replace the RFID2 Harness. |
| 6 | Check all pins on the RFID Harness PL7.2.17 for continuity. 1. Disconnect P/J3411 and P/J34. 2. Check continuity between P3411<=>J34. | Replace the Engine Control Board (page 8-104). | Replace the RFID Harness. |

Non-Phaser 6300/6350 Fuser

A CRUM-ID error indicates that a non-Phaser 6300 Fuser is installed.

Applicable Status Code:

Code 94: Fuser CRUM ID Error

Initial Actions:

- Ensure that the Fuser latches are fully latched and cycle printer power.
- If the problem persists, follow the procedure below

Troubleshooting Reference Table

| Applicable Parts | Wiring and Plug/Jack References |
|---|---|
| <ul style="list-style-type: none"> ■ Fuser, PL5.1.1 ■ FSR/ADC Harness, PL5.2.28 ■ Engine Control Board, PL9.1.16 | <ul style="list-style-type: none"> ■ Print Engine Map 2 - P/J Locator (page 10-6) ■ Print Engine Map 3- P/J Locator (page 10-7) ■ Print Engine Fuser Wiring (page 10-22) |

Warning

Avoid the potential of electric shock by removing the power cord from the wall outlet prior to performing the following procedure.

Caution

Allow adequate time for the Fuser to cool before servicing the printer.

Troubleshooting Procedure Table

| Step | Actions and Questions | Yes | No |
|------|--|--|-------------------------------|
| 1 | Check the Fuser part number. Is the Fuser a genuine Xerox part. | Go to Step 2. | Replace the Fuser (page 8-5). |
| 2 | Check the Fuser for damage. Is the Fuser damaged? | Replace the Fuser. | Go to Step 3. |
| 3 | Check Fuser installation. Remove and reinstall the Fuser. Does the error persist? | Go to Step 4 | Complete |
| 4 | Replace the Fuser. Does the error persist? | Go to Step 5. | Complete |
| 5 | Check all pins on the FSR/ADC Harness PL5.2.28 for continuity. 1. Disconnect P/J36 and P/J361. 2. Check continuity between J36<=>J361. | Replace the Engine Control Board (page 8-104). | Replace the FSR/ADC Harness. |

Replace Maintenance Kit

The Printer detected an error condition that indicates the parts listed below need to be replaced. This will ensure the rated engine life of 600,000 prints is achievable.

Applicable Status Code:

Code 101: Replace Maintenance Kit

Troubleshooting Reference Table

| Applicable Parts | Wiring and Plug/Jack References |
|--|---------------------------------|
| <ul style="list-style-type: none"> ■ Long-Life Maintenance Kit, 650-4360-00 | |

Troubleshooting Procedure Table

| Step | Actions and Questions | Yes | No |
|------|---|--|------------------------------|
| 1 | Follow the procedure starting on page 7-4 and replace all concerned parts. Have all parts outlined in the procedure been replaced? | Go to the Hidden Service menu on the Control Panel and Reset the Maintenance Kit Life count. | Replace all concerned parts. |

Non-Xerox Imaging Unit

A Imaging Unit CRUM I.D. error indicates that a non-Xerox Imaging Unit is installed.

Applicable Status Code:

Code 95: CRUM I.D. error.

Troubleshooting Reference Table

| Applicable Parts | Wiring and Plug/Jack References |
|--|---|
| <ul style="list-style-type: none"> ■ Imaging Unit, PL6.1.1 ■ CRUM Board, PL7.1.4 ■ PHD2 Harness, PL7.1.7 ■ FAN/PHD/MOT Harness, PL10.1.9 | <ul style="list-style-type: none"> ■ Print Engine Map 2 - P/J Locator (page 10-6) ■ Print Engine Map 3 - P/J Locator (page 10-7) ■ Print Engine Laser Unit Wiring (page 10-23) |

Troubleshooting Procedure Table

| Step | Actions and Questions | Yes | No |
|------|--|--|----------------------------------|
| 1 | Check the Imaging Unit part number. Is the Imaging Unit a genuine Xerox Phaser 6300/6350 part? | Go to Step 2. | Replace the Imaging Unit. |
| 2 | Check the Imaging Unit for damage. Is the Imaging Unit damaged? | Replace the Imaging Unit (page 8-5). | Go to Step 4. |
| 3 | Replace the Imaging Unit. Does the error persist? | Go to Step 5. | Complete |
| 4 | Check the CRUM connection. Is P/J710 connected to the harness? | Go to Step 3. | Connect the CRUM |
| 5 | Check all pins on the PHD2 Harness PL7.1.7 for continuity. 1. Disconnect P/J710 and P/J484. 2. Check continuity between J710 <=> J484. | Go to Step 4. | Replace the PHD2 Harness. |
| 6 | Check all pins on the FAN/PHD/MOT Harness PL10.1.9 for continuity. 1. Disconnect P/J48 and P/J484. 2. Check continuity between J48<=>P484. | Go to Step 5. | Replace the FAN/PHD/MOT Harness. |
| 7 | Replace the Imaging Unit. Does the error persist? | Replace the Engine Control Board (page 8-104). | Complete |

Metered Toner Is not Enabled

A metered toner cartridge is installed while metered toner is not enabled.

Initial Actions:

- Ensure that the Toner Cartridge installed matches the printer's configuration.
- Cycle the printer's power.
- If the problem persists follow the procedure below.

Applicable Status Code:

Code 223: Metered Toner Is not Enabled

Troubleshooting Reference Table

| Applicable Parts | Wiring and Plug/Jack References |
|---|---------------------------------|
| <ul style="list-style-type: none">■ Toner Cartridge (Y) PL7.2.8■ Toner Cartridge (M) PL7.2.9■ Toner Cartridge (C) PL7.2.10■ Toner Cartridge (K) PL7.2.11 | |

Troubleshooting Procedure Table

| Step | Actions and Questions | Yes | No |
|------|---|--|--|
| 1 | Check the configuration of the Printer. Is the printer covered under a Metered Toner contract? | Enable the Metered Toner via the front Panel (page 1-4). | Replace the affected Toner Cartridge with a Non-Metered Toner Cartridge. |

Tray and Media Errors

When a tray is pulled out that prevents printing during a print job, an error condition exists. When a tray is pulled out while no job is printing or that does not prevent printing during a print job, a warning condition exists.

Insert Tray [2] or Tray [2] Missing

The Tray 2 Paper Size Switch indicates that Tray 2 is not installed.

Applicable Status Codes:

Code 160: Insert Tray 2

Warning: Tray 2 is missing

Initial Actions:

- Remove the tray and inspect the tray cavity to ensure that it is free of obstructions or debris.
- Reinstall the tray and cycle printer power.
- If the problem persists, follow the procedure below.

Troubleshooting Reference Table

| Applicable Parts | Wiring and Plug/Jack References |
|--|---|
| <ul style="list-style-type: none">■ Paper Size Switch, PL3.2.5■ Paper Tray, PL2.1.1 | <ul style="list-style-type: none">■ Paper Size Switch Signals table (page 2-7)■ Print Engine Map 4 - P/J Locator (page 10-8)■ Print Engine Tray 2 Wiring (page 10-18) |

Troubleshooting Procedure Table

| Step | Actions and Questions | Yes | No |
|------|--|--|---------------|
| 1 | Check the following for evidence of fault or damage: <ul style="list-style-type: none">■ Tray 2 Paper Size Switch, PL3.2.5■ Tray 2 Paper Size Switch Actuators, PL2.1.10■ Paper Tray, PL2.1.1 Is there any damage? | Replace any damaged parts. | Go to Step 2. |
| 2 | Test the Tray 2 Paper Size Switches. Run the Service Diagnostics Paper Size Switch test. Use the table on (page 2-7). Do the switches function correctly? | Replace the Engine Control Board (page 8-104). | Go to Step 3. |

Troubleshooting Procedure Table (Continued)

| Step | Actions and Questions | Yes | No |
|------|---|--|--|
| 3 | Check the Paper Size Switch signals. 1. Disconnect P/J47. 2. Verify +3.3 V on pins P/J47-1 <=> P47-3 P/J47-2 <=> P47-3 P/J47-4 <=> P47-3 Is there +3.3 V when actuated? | Go to Step 4 | Replace the Paper Size Switch (page 8-25). |
| 4 | Check all pins on the FDR Harness for continuity. 1. Disconnect P/J47 and P/J471. 2. Check continuity between J47 <=> J471. | Replace the Engine Control Board (page 8-104). | Replace the FDR Harness. |

Insert Tray [3] [4] [5] or Tray [3] [4] [5] Missing

The tray's Paper Size Switch indicates that the reported tray is not installed. Tray 3 can refer to either optional feeder.

Applicable Status Codes:

Code 160: Insert Tray 3

Code 162: Insert Tray 4

Code 163: Insert Tray 5

Warning: Tray 3 is missing

Warning: Tray 4 is missing

Warning: Tray 5 is missing

Initial Actions:

- Remove the affected tray and inspect the tray cavity to ensure that it is free of obstructions or debris.
- Reinstall the tray and cycle printer power.
- If the problem persists, follow the procedure below.

Troubleshooting Reference Table

| Applicable Parts | Wiring and Plug/Jack References |
|---|--|
| For 550-Sheet Feeder: <ul style="list-style-type: none"> ■ Paper Size Switch, PL11.2.6 ■ Paper Tray, PL11.4.1 ■ SIZE Harness, PL11.2.8 ■ OPFREC Harness, PL11.1.6 | <ul style="list-style-type: none"> ■ Paper Size Switch Signals table (page 2-7) ■ 550-Sheet Feeder P/J Locator (page 10-12) ■ 550-Sheet Feeder Tray Wiring (page 10-35) ■ 1100-Sheet Feeder P/J Locator (page 10-10) ■ 1100-Sheet Feeder Tray Wiring (page 10-31) |
| For 1100-Sheet Feeder: <ul style="list-style-type: none"> ■ Paper Size Switch, PL12.2.6 ■ Paper Tray, PL12.6.1 ■ SIZE2 Harness, PL12.3.5 ■ OPFREC2 Harness, PL12.3.1 | |

Troubleshooting Procedure Table

| Step | Actions and Questions | Yes | No |
|------|---|--|---|
| 1 | Check the affected tray for damage: <ul style="list-style-type: none"> ■ Paper Size Switch, PL11.2.6, PL12.2.6 ■ Paper Size Switch Actuators, PL11.4.10, PL12.6.10 ■ Paper Tray, PL11.4.1, PL12.6.1 Is there any damage? | Replace the damaged parts. | Go to Step 2. |
| 2 | Test the affected Paper Size Switch. Run the Service Diagnostics Paper Size Switch test. Use the table on (page 2-7). Do the switches function correctly? | Replace the Engine Control Board (page 8-104). | Go to Step 3. |
| 3 | Check the Paper Size Switch signals. Verify +3.3 V on pins: P/J821-1 <=> P/J80-4 P/J821-3 <=> P/J80-2 P/J821-4 <=> P/J80-1 Is there +3.3 V when actuated? | Go to Step 4 | Replace the affected Paper Size Switch (page 8-25). |
| 4 | Check all pins on the SIZE Harness for continuity. 1. Disconnect P/J80 and P/J821. 2. Check continuity between J80 <=> J821 | Go to Step 5. | Replace the SIZE Harness. |
| 5 | Check all pins on the OPFREC Harness for continuity. 1. Disconnect P/J171 or P/J172 and P/J83. 2. Check continuity between J171/2 <=> P83 | Replace the Engine Control Board (page 8-104). | Replace the affected OPFREC Harness. |

Out of Paper; Load Tray 1 (MPT) with [size] [type]

The Tray 1 (MPT) No Paper Sensor indicates Tray 1 (MPT) is empty.

Applicable Status Code:

Code 165: Out of Paper; Load Tray 1 (MPT)

Initial Actions:

- Inspect the tray to ensure that it is free of obstructions, is loaded with supported media, and the guides are adjusted correctly.
- Cycle printer power.
- If the problem persists, follow the procedure below

Troubleshooting Reference Table

| Applicable Parts | Wiring and Plug/Jack References |
|--|--|
| <ul style="list-style-type: none">■ No Paper Sensor, PL5.3.14■ No Paper Sensor Actuator, PL5.3.15■ FRONT/DUP Harness, PL5.3.28 | <ul style="list-style-type: none">■ Print Engine Map 1 - P/J Locator (page 10-5)■ Print Engine Paper Feed Wiring (page 10-26) |

Troubleshooting Procedure Table

| Step | Actions and Questions | Yes | No |
|------|--|--|--------------------------------|
| 1 | Fill Tray 1 (MPT) with paper. Does the error persist? | Go to Step 2. | Complete. |
| 2 | Check the following for evidence of fault or damage: <ul style="list-style-type: none">■ Tray 1 (MPT) No Paper Sensor, PL5.3.14■ Sensor Actuator, PL5.3.15 Is there any damage? | Replace any damaged parts. | Go to Step 3. |
| 3 | Test the Tray 1 (MPT) No Paper Sensor. Run the Service Diagnostics Tray 1 (MPT) No Paper Sensor test. Does the sensor function correctly? | Replace the Engine Control Board (page 8-104). | Go to Step 4. |
| 4 | Check the Tray 1 (MPT) No Paper Sensor signal. Is there +3.3 V across P/J135-1 <=> P/J135-2? | Replace the sensor (page 8-45). | Go to Step 5. |
| 5 | Check all pins on the FRONT/DUP Harness PL5.3.28 for continuity. 1. Disconnect P/J13 and P/J135. 2. Check continuity between J13 <=> J134. | Replace the Engine Control Board (page 8-104). | Replace the FRONT/DUP Harness. |

Out of Paper; Load Tray [2][3][4][5] with [size][type]

The No Paper Sensor for the indicated tray reports the tray is empty.

Applicable Status Codes:

Code 166: Out of Paper; Load Tray 2

Code 167: Out of Paper; Load Tray 3

Code 168: Out of Paper; Load Tray 4

Code 169: Out of Paper; Load Tray 5

Warning: No Paper in Tray 2

Warning: No Paper in Tray 3

Warning: No Paper in Tray 4

Warning: No Paper in Tray 5

Initial Actions:

- Inspect the tray to ensure that it is free of obstructions, is loaded with supported media and the guides are adjusted correctly.
- Cycle printer power.
- If the problem persists, follow the procedure below.

Troubleshooting Reference Table

| Applicable Parts | Wiring and Plug/Jack References |
|---|--|
| For Tray 2: <ul style="list-style-type: none">■ No Paper Sensor, PL3.3.7■ No Paper Actuator, PL3.3.20■ FDR Harness, 3.3.22 | <ul style="list-style-type: none">■ Print Engine Map 4 - P/J Locator (page 10-8)■ Print Engine Tray 2 Wiring (page 10-18)■ 550-Sheet Feeder P/J Locator (page 10-12)■ 550-Sheet Feeder Tray Wiring (page 10-35)■ 1100-Sheet Feeder P/J Locator (page 10-10)■ 1100-Sheet Feeder Tray Wiring (page 10-31) |
| For 550-Sheet Feeder: <ul style="list-style-type: none">■ No Paper Sensor, PL11.3.7■ No Paper Actuator, PL11.3.22■ OPFDR Harness, 11.3.24 | |
| For 1100-Sheet Feeder: <ul style="list-style-type: none">■ No Paper Sensor, PL12.4.7■ No Paper Actuator, PL12.3.22■ OPFDR2 Harness, 12.3.7 | |

Troubleshooting Procedure Table

| Step | Actions and Questions | Yes | No |
|------|---|--|------------------------------|
| 1 | Fill the tray. Does the error occur even if the tray is full? | Go to Step 2. | Complete |
| 2 | Check the following for evidence of fault or damage: <ul style="list-style-type: none"> ■ No Paper Sensor, PL3.3.7, PL11.3.7, PL12.4.7 ■ No Paper Actuator, PL3.3.20, PL11.3.22, PL12.3.22 Is there any damage? | Replace any damaged parts. | Go to Step 3. |
| 3 | Test the No Paper Sensor. for the affected tray. Run the Service Diagnostics No Paper Sensor test. Does the sensor function correctly? | Replace the Engine Control Board (page 8-104). | Go to Step 4. |
| 4 | Check the No Paper Sensor signal. For Tray 2: Is there +3.3 V across P/J472-1 <=> P/J472? For Tray 3, 4, and 5: Is there +3.3 V across P/J822-1 <=> P/J822-2? | Go to Step 5. | Replace the No Paper Sensor. |
| 5 | Check all pins on the FDR Harness for continuity. For Tray 2: 1. Disconnect P/J47 and P/J472. 2. Check continuity between J47 <=> J472. For Tray 3, 4, 5: 1. Disconnect P/J85 and P/J822. 2. Check continuity between J85 <=> J822. | Replace the Engine Control Board (page 8-104). | Replace the FDR Harness. |

Output Tray Is Full, Unload Paper

The Full Stack Sensor indicates the output tray is full.

Applicable Status Code:

Code 191: Output Tray is Full

Initial Actions:

- Ensure that the output tray is empty and the actuator is in the correct position.
- Cycle printer power.
- If the problem persists, follow the procedure below.

Troubleshooting Reference Table

| Applicable Parts | Wiring and Plug/Jack References |
|---|---|
| <ul style="list-style-type: none">■ Full Stack Sensor, PL5.4.1■ Full Stack Actuator, PL5.4.2■ FRONT/DUP Harness, PL5.3.28 | <ul style="list-style-type: none">■ Print Engine Map 1 - P/J Locator (page 10-5)■ Print Engine Map 3 - P/J Locator (page 10-7)■ Print Engine Paper Feed Wiring (page 10-26) |

Troubleshooting Procedure Table

| Step | Actions and Questions | Yes | No |
|------|---|--|--------------------------------|
| 1 | Check the following for evidence of fault or damage: <ul style="list-style-type: none">■ Full Stack Sensor, PL5.4.1■ Full Stack Sensor Actuator, PL5.4.2 | Replace the parts concerned. | Go to Step 2. |
| 2 | Test the Full Stack Sensor. Run the Service Diagnostics Full Stack Sensor test. Does the sensor function correctly? | Replace the Engine Control Board (page 8-104). | Go to Step 3. |
| 3 | Check the Full Stack Sensor connection. Is P/J134 connected to the harness? | Go to Step 4. | Reconnect the sensor. |
| 4 | Replace the Full Stack Sensor. Does the error persist? | Go to Step 5. | Complete |
| 5 | Check all pins on the FRONT/DUP Harness PL5.3.28 for continuity. 1. Disconnect P/J13 and P/J134. 2. Check continuity between J13 <=> J134. | Replace the Engine Control Board (page 8-104). | Replace the FRONT/DUP Harness. |

Media Mismatch Errors

Wrong Paper Size; Load Tray 1 (MPT) with [size][type]

Tray 1 (MPT) Paper Size mismatch error.

Applicable Status Code:

Code 176: Wrong Paper Size; Load Tray 1 (MPT) with [size] [type]

Initial Actions:

- Inspect the tray to ensure that it is free of obstructions, is loaded with supported media and the guides are adjusted correctly.
- Cycle printer power.
- If the problem persists, follow the procedure below.

Troubleshooting Reference Table

| Applicable Parts | Wiring and Plug/Jack References |
|---|---|
| <ul style="list-style-type: none">■ Tray 1 (MPT) No Paper Sensor, PL3.2.5 | <ul style="list-style-type: none">■ Paper Size Switch Signals table (page 2-7)■ Print Engine Map 1 - P/J Locator (page 10-5)■ Print Engine Paper Feed Wiring (page 10-26) |

Troubleshooting Procedure Table

| Step | Actions and Questions | Yes | No |
|------|--|---|--|
| 1 | Check the Tray 1 (MPT) No Paper Sensor for evidence of fault or damage: Is there any damage? | Replace any damaged parts. | Go to Step 2. |
| 2 | Test the Tray 1 (MPT) No Paper Sensor Run the Service Diagnostics Tray 1 (MPT) No Paper Sensor test. Does the sensor function correctly? | Go to Step 4. | Go to Step 3. |
| 3 | Check all pins on the FRONT/DUP Harness for continuity. 1. Disconnect P/J13 and P/J135. 2. Check continuity between J13<=>J135. | Go to Step 4. | Replace the FRONT/DUP Harness. |
| 4 | Check the No Paper Sensor signal at the Engine Control Board. Is there 3.3V at P13-15 when actuated? | Replace the No Paper Sensor (page 8-45) | Replace the Engine Control Board (page 8-104). |

Wrong Paper Size; Load Tray 2 with [size][type]

Tray 2 Paper Size mismatch error.

Applicable Status Code:

Code 177: Wrong Paper Size; Load Tray 2 with [size] [type]

Initial Actions:

- Inspect the tray to ensure that it is free of obstructions, is loaded with supported media, and the guides are adjusted correctly.
- Cycle printer power.
- If the problem persists, follow the procedure below.

Troubleshooting Reference Table

| Applicable Parts | Wiring and Plug/Jack References |
|--|---|
| <ul style="list-style-type: none">■ Paper Size Switch, PL3.2.5■ Paper Tray, PL2.1.1 | <ul style="list-style-type: none">■ Paper Size Switch Signals table (page 2-7)■ Print Engine Map 4 - P/J Locator (page 10-8)■ Print Engine Tray 2 Wiring (page 10-18) |

Troubleshooting Procedure Table

| Step | Actions and Questions | Yes | No |
|------|---|--|--|
| 1 | Check the following for evidence of fault or damage: <ul style="list-style-type: none">■ Tray 2 Paper Size Switch, PL3.2.5■ Tray 2 Size Actuators, PL2.1.10■ Tray 2 Paper Tray, PL2.1.1 Is there any damage? | Replace any damaged parts. | Go to Step 2. |
| 2 | Test the Tray 2 Paper Size Switches. Run the Service Diagnostics Paper Size Switch test. Use the table on (page 2-7). Do the switches function correctly? | Replace the Engine Control Board (page 8-104). | Go to Step 3. |
| 3 | Check the Paper Size Switch signals. Disconnect P/J47. Verify +3.3 V on pins <ul style="list-style-type: none">P/J47-1 <=> P47-3P/J47-2 <=> P47-3P/J47-4 <=> P47-3 Is there +3.3 V when actuated? | Go to Step 4 | Replace the Paper Size Switch (page 8-25). |
| 4 | Check all pins on the FDR Harness for continuity. <ol style="list-style-type: none">1. Disconnect P/J47 and P/J471.2. Check continuity between J47<=>J471. | Replace the Engine Control Board (page 8-104). | Replace the FDR Harness. |

Wrong Paper Size; Load Tray [3][4][5] with [size][type]

Tray [3] [4] [5] paper size mismatch error.

Applicable Status Codes:

Code 178: Wrong Paper Size; Load Tray 3 with [size] [type]

Code 179: Wrong Paper Size; Load Tray 4 with [size] [type]

Code 180: Wrong Paper Size; Load Tray 5 with [size] [type]

Initial Actions:

- Inspect the tray to ensure that it is free of obstructions, is loaded with supported media, and the guides are adjusted correctly.
- Cycle printer power.
- If the problem persists, follow the procedure below.

Troubleshooting Reference Table

| Applicable Parts | Wiring and Plug/Jack References |
|--|---|
| For 550-Sheet Feeder: <ul style="list-style-type: none">■ Paper Size Switch, PL11.2.6■ Paper Tray, PL11.4.1■ SIZE Harness, PL11.2.8 | <ul style="list-style-type: none">■ Paper Size Switch Signal Definitions table (page 2-7)■ 550-Sheet Feeder P/J Locator (page 10-12)■ 550-Sheet Feeder Tray Wiring (page 10-35)■ 1100-Sheet Feeder P/J Locator (page 10-10)■ 1100-Sheet Feeder Tray Wiring (page 10-31) |
| For 1100-Sheet Feeder: <ul style="list-style-type: none">■ Paper Size Switch, PL12.2.6■ Paper Tray, PL12.6.1■ SIZE2 Harness, PL12.3.5 | |

Troubleshooting Procedure Table

| Step | Actions and Questions | Yes | No |
|------|--|--|---------------|
| 1 | Check the affected tray for damaged parts: <ul style="list-style-type: none">■ Paper Size Switch, PL11.2.6, PL12.2.6■ Paper Tray, PL11.4.1, PL12.6.1 Are any parts damaged? | Replace damaged parts. | Go to Step 2. |
| 2 | Test the affected Paper Size Switch. Run the Service Diagnostics Paper Size Switch test. Use the table on (page 2-7). Do the switches function correctly? | Replace the Engine Control Board (page 8-104). | Go to Step 3. |

Troubleshooting Procedure Table (Continued)

| Step | Actions and Questions | Yes | No |
|------|--|--|---|
| 3 | Check the Paper Size Switch signals. Verify +3.3 V on pins: P/J821-1 <=> P/J80-4 P/J821-3 <=> P/J80-2 P/J821-4 <=> P/J80-1 Is there +3.3 V when actuated? | Go to Step 4. | Replace the affected Paper Size Switch (page 8-25). |
| 4 | Check all pins on the SIZE Harness for continuity. 1. Disconnect P/J80 and P/J821. 2. Check continuity between J80 <=> J821. | Go to Step 5. | Replace the Size Harness. |
| 5 | Check all pins on the OPFREC Harness continuity. 1. Disconnect P/J171 or P/J172 and P/J83. 2. Check for continuity between J171/2 <=> P83. | Replace the Engine Control Board (page 8-104). | Replace the affected OPFREC Harness. |

Configuration Errors

Invalid or Missing Configuration Card

The printer's Configuration Card is missing or defective.

Troubleshooting Reference Table

| Applicable Parts | Wiring and Plug/Jack References |
|--|---------------------------------|
| <ul style="list-style-type: none"> ■ Configuration Card, PL9.1.31 ■ Image Processor Board, PL9.1.3 | |

Troubleshooting Procedure Table

| Step | Actions and Questions | Yes | No |
|------|--|--|-----------------|
| 1 | Check the Configuration Card installation. Remove and reinsert the Configuration Card. Does the error still occur? | Replace the Configuration Card. If the problem persists, replace the I/P Board (page 8-98). | Problem solved. |

Duplicate IP Address Detected

Another device on the network is using the IP address assigned to this printer.

Troubleshooting Reference Table

| Applicable Parts | Wiring and Plug/Jack References |
|----------------------------------|---------------------------------|
| ■ Image Processor Board, PL9.1.3 | |

Troubleshooting Procedure Table

| Step | Actions and Questions | Yes | No |
|------|--|--|-------------------------------|
| 1 | Check the TCP/IP Address stored in the printer's NVRAM. Is the address correct for the printer? | Advise the customer of the address conflict. | Enter the correct IP address. |

Unsupported Configuration

More than one 550-Sheet Feeder is detected. Stacking more than one 550-Sheet Feeder is not supported and results in this error condition.

Initial Actions:

- Ensure that only one 550 sheet feeder is installed.
- Clean the CTD (ADC) Sensor, then cycle the printer's power.
- If the problem persists follow the procedure below.

Applicable Status Code:

Code 164: Unsupported Configuration.

Troubleshooting Reference Table

| Applicable Parts | Wiring and Plug/Jack References |
|--------------------------------------|---|
| ■ 550-Sheet Feeder w/ tray, PL11.1.1 | ■ 550-Sheet Feeder P/J Locator (page 10-12) ■ 550-Sheet Feeder Drive Wiring (page 10-34) |

Troubleshooting Procedure Table

| Step | Actions and Questions | Yes | No |
|------|---|--------------------------------------|---------------|
| 1 | Check the configuration of the Printer. Is more than one 550-Sheet Feeder installed? | Remove one of the 550-Sheet Feeders. | Go to Step 2. |

Troubleshooting Procedure Table (Continued)

| Step | Actions and Questions | Yes | No |
|------|--|--|----------|
| 2 | Replace the 550-Sheet Feeder. Does the error persist? | Replace the Engine Control Board (page 8-104). | Complete |

Fatal Error Procedures

Laser Failure

An error was detected in the Laser Unit.

Applicable Status Codes:

Code 07: Laser power has failed

Code 08: Start of Scan (SOS) failure 1

Code 09: Start of Scan (SOS) failure 2

Code 10: Warm up failure

Code 11: This is the generic laser fault used by the engine if a lower level error cannot be reported to the controller.

Troubleshooting Reference Table

| Applicable Parts | Wiring and Plug/Jack References |
|---|---|
| <ul style="list-style-type: none"> ■ Laser Unit, PL6.1.2 ■ ROS Harness, PL6.1.3 ■ Engine Control Board, PL9.1.16 | <ul style="list-style-type: none"> ■ Print Engine Map 3 - P/J locator (page 10-7) ■ Print Engine Laser Unit Wiring (page 10-23) |

Troubleshooting Procedure Table

| Step | Actions and Questions | Yes | No |
|------|---|--|--------------------------|
| 1 | Check the Laser Unit connections. Are P/J15 and P/J151 connected? | Go to Step 2. | Connect the Laser Unit. |
| 2 | Remove and reseal ROS Harness connector J151 to the Laser Unit. Does the error persist? | Go to Step 3. | Complete |
| 3 | Replace the Laser Unit (page 8-76). Does the error persist? | Go to Step 4. | Complete |
| 4 | Check all pins on the ROS Harness PL6.1.3 for continuity. 1. Disconnect P/J15 and P/J151. 2. Check continuity between J15 <=> J151. | Replace the Engine Control Board (page 8-104). | Replace the ROS Harness. |

Density Sensor Failure

An error was detected in the CTD (ADC) sensor.

Applicable Status Codes:

Code 13: Density Sensor Failure.

Code 14: Density Limit Over Output.

Code 15: Density Limit.

Code 16: This is the generic fault used by the engine if a lower level error cannot be reported to the controller.

Troubleshooting Reference Table

| Applicable Parts | Wiring and Plug/Jack References |
|---|--|
| <ul style="list-style-type: none">■ Transfer Roller, PL5.1.4■ FSR/ADC Harness, PL5.2.28■ CTD(ADC) Sensor Holder, PL5.2.19 | <ul style="list-style-type: none">■ Print Engine Map 2 - P/J Locator (page 10-6)■ Print Engine Wiring Xerographics (1/2) (page 10-24) |

Troubleshooting Procedure Table

| Step | Actions and Questions | Yes | No |
|------|--|--|--|
| 1 | Check the following for evidence of fault or damage: <ul style="list-style-type: none">■ Transfer Roller, PL5.1.4■ CTD (ADC) Sensor Holder, PL5.2.19 Are any parts damaged? | Replace any damaged parts. | Go to Step 2. |
| 2 | Clean the CTD (ADC) Sensor. Does the error persist? | Go to Step 3. | Complete |
| 3 | Test the CTD (ADC) Sensor. Run the Service Diagnostics CTD (ADC) Sensor test. Does the sensor function correctly? | Go to Step 4. | Go to Step 5. |
| 4 | Replace the Transfer Roller. Does the error persist? | Go to Step 5. | Complete |
| 5 | Check all pins on the FSR/ADC Harness PL5.2.28 for continuity. 1. Disconnect P/J36 and P/J136. 2. Check continuity between J36 <=> J136. | Go to Step 6. | Replace the FSR/ADC Harness. |
| 6 | Check the CTD (ADC) Sensor signal. Disconnect P/J136. Is there 0 V across P136-4 <=> P136-1? | Replace the CTD (ADC) Sensor Holder (page 8-71). | Replace the Engine Control Board (page 8-104). |

Fuser Failure

The Fuser temperature regulation has failed.

Applicable Status Codes:

Code 40: The temperature sensor sensed an overheat condition.

Code 41: The temperature sensor sensed a low temperature condition.

Code 42: Temperature sensor not providing an output.

Code 43: Warm up failure.

Troubleshooting Reference Table

| Applicable Parts | Wiring and Plug/Jack References |
|---|---|
| <ul style="list-style-type: none">■ Fuser, PL5.1.1■ FSR/ADC Harness, PL5.2.28■ LVPS, PL9.1.6■ Engine Control Board, PL9.1.16 | <ul style="list-style-type: none">■ Print Engine Map 2 - P/J Locator (page 10-6)■ Print Engine Map 3- P/J Locator (page 10-7)■ Print Engine Fuser Wiring (page 10-22) |

Warning

Avoid the potential of electric shock by removing the power cord from the wall outlet prior to performing the following procedure.

Caution

Allow adequate time for the Fuser to cool before servicing the printer.

Troubleshooting Procedure Table

| Step | Actions and Questions | Yes | No |
|------|--|--|-------------------------------|
| 1 | Check the Fuser label for the correct rating. Is the Fuser properly rated (110v / 220v)? | Go to Step 2. | Replace the Fuser (page 8-5). |
| 2 | Check the Fuser for damage. Is the Fuser connector damaged? | Replace the Fuser (page 8-5). | Go to Step 3. |
| 3 | Replace the Fuser (page 8-5). Does the error persist? | Go to Step 4. | Complete |
| 4 | Replace the LVPS (page 8-99). Does the error persist? | Go to Step 5. | Complete |
| 5 | Check all pins on the FSR/ADC Harness PL5.2.28 for continuity. 1. Disconnect P/J36 and P/J361. 2. Check continuity between J36 <=> J361. | Replace the Engine Control Board (page 8-104). | Replace the FSR/ADC Harness. |

Fuser Failure

The Fuser heater control circuitry has failed.

Applicable Status Code:

Code 44: Heater Control failure.

Troubleshooting Reference Table

| Applicable Parts | Wiring and Plug/Jack References |
|--|---|
| <ul style="list-style-type: none">■ Fuser, PL5.1.1■ FSR/ADC Harness, PL5.2.28■ LVPS, PL9.1.6■ Engine Control Board, PL9.1.16■ LV Harness, PL10.1.2 | <ul style="list-style-type: none">■ Print Engine Map 2 - P/J Locator (page 10-6)■ Print Engine Map 3- P/J Locator (page 10-7)■ Print Engine Fuser Wiring (page 10-22) |

Warning

Avoid the potential of electric shock by removing the power cord from the wall outlet prior to performing the following procedure.

Caution

Allow adequate time for the Fuser to cool before servicing the printer.

Troubleshooting Procedure Table

| Step | Actions and Questions | Yes | No |
|------|--|--|-------------------------------|
| 1 | Check the Fuser label for the correct rating. Is the Fuser properly rated (110v / 220v)? | Go to Step 2. | Replace the Fuser (page 8-5). |
| 2 | Check the Fuser for damage. Is the Fuser connector damaged? | Replace any damaged parts. | Go to Step 3. |
| 3 | Replace the Fuser (page 8-5). Does the error persist? | Go to Step 4. | Complete |
| 4 | Replace the LVPS (page 8-99). Does the error persist? | Go to Step 5. | Complete |
| 5 | Check all pins on the FSR/ADC Harness PL5.2.28 for continuity. 1. Disconnect P/J162 and P/J361. 2. Check continuity between J162<=>J361. | Go to Step 6. | Replace the FSR/ADC Harness. |
| 6 | Check all pins on the LV Harness PL10.1.2 for continuity. 1. Disconnect P/J61 and P/J165. 2. Check continuity between J61 <=> J165. | Replace the Engine Control Board (page 8-104). | Replace the LV Harness. |

Fuser Failure

The Non Contact (NC) circuitry has failed.

Applicable Status Codes:

Code 45: NC Sensor circuit Failure

Code 47: This is the generic Fuser code displayed when the printer cannot generate a specific error. This error code can represent any Fuser error code from 40 through 47. In this instance, all of the Fuser Failure troubleshooting procedures need to be completed until the error is resolved.

Troubleshooting Reference Table

| Applicable Parts | Wiring and Plug/Jack References |
|---|---|
| <ul style="list-style-type: none">■ Fuser, PL5.1.1■ FSR/ADC Harness, PL5.2.28■ Engine Control Board, PL9.1.16 | <ul style="list-style-type: none">■ Print Engine Map 2 - P/J Locator (page 10-6)■ Print Engine Map 3- P/J Locator (page 10-7)■ Print Engine Fuser Wiring (page 10-22) |

Warning

Avoid the potential of electric shock by removing the power cord from the wall outlet prior to performing the following procedure.

Caution

Allow adequate time for the Fuser to cool before servicing the printer.

Troubleshooting Procedure Table

| Step | Actions and Questions | Yes | No |
|------|--|--|-------------------------------|
| 1 | Check the Fuser label for the correct rating. Is the Fuser properly rated (110v/220v)? | Go to Step 2. | Replace the Fuser (page 8-5). |
| 2 | Check the Fuser for damage. Is the Fuser connector damaged? | Repair or replace the Fuser. | Go to Step 3. |
| 3 | Replace the Fuser (page 8-5). Does the error persist? | Go to Step 4. | Complete |
| 4 | Check all pins on the FSR/ADC Harness PL5.2.28 for continuity. 1. Disconnect P/J36 and P/J361. 2. Check continuity between J36 <=> J361. | Replace the Engine Control Board (page 8-104). | Replace the FSR/ADC Harness. |

Fuser Fan Failure

The Fuser Fan rotation signal indicates to the Engine Control Board that the fan is no longer operational.

Applicable Status Code:

Code 50: Fuser Fan Failure

Troubleshooting Reference Table

| Applicable Parts | Wiring and Plug/Jack References |
|--|--|
| <ul style="list-style-type: none"> ■ Fuser Fan, PL5.3.31 ■ FAN/PHD/MOT Harness, PL10.1.9 ■ Engine Control Board, PL9.1.16 | <ul style="list-style-type: none"> ■ Print Engine Map 1 - P/J Locator (page 10-5) ■ Print Engine Drive Wiring (page 10-19) |

Troubleshooting Procedure Table

| Step | Actions and Questions | Yes | No |
|------|--|--|------------------------------------|
| 1 | Check the Fuser Fan for damage. Remove the Front Cover. Is the fan damaged? | Replace the Fuser Fan (page 8-66). | Go to Step 2. |
| 2 | Check the Fuser Fan connection. Is P/J482 connected to the harness? | Go to Step 2. | Reconnect the Fan. |
| 3 | Check orientation of the Fuser Fan. Does the Fan's label face into the chute? | Go to Step 3. | Correct the installation. |
| 4 | Test the Fuser Fan. Run the Service Diagnostics Fuser Fan test. Does the Fan operate. | Go to Step 6. | Go to Step 5. |
| 5 | Check all pins on the FAN/PHD/MOT Harness PL10.1.9 for continuity. 1. Disconnect P/J48 and P/J482. 2. Check continuity between J48 <=> P483. | Go to Step 5. | Replace the FAN/PHD/MOT Harness. |
| 6 | Check the fan rotation signal. Print one sheet. Is there +3.3 V across P/J48-A12 <=> P/J48-A13? | Replace the Engine Control Board (page 8-104). | Replace the Fuser Fan (page 8-66). |

Rear Fan Failure

The Rear Fan rotation signal indicates the fan is no longer operational.

Applicable Status Code:

Code 51: Rear Fan Failure

Troubleshooting Reference Table

| Applicable Parts | Wiring and Plug/Jack References |
|--|---|
| <ul style="list-style-type: none">■ Rear Fan, PL1.1.19■ LVPS, PL9.1.6■ Engine Control Board, PL9.1.16■ LV Harness, PL10.1.2 | <ul style="list-style-type: none">■ Print Engine Map 2 - P/J Locator (page 10-6)■ Print Engine Power Wiring (page 10-17) |

Troubleshooting Procedure Table

| Step | Actions and Questions | Yes | No |
|------|---|------------------------------------|--|
| 1 | Check the Rear Fan for damage. Remove the Rear Cover. Is the fan damaged? | Replace the Rear Fan (page 8-102). | Go to Step 2. |
| 2 | Check the Rear Fan connection. Is P/J166 connected to the harness? | Go to Step 3. | Connect the Fan. |
| 3 | Check orientation of the Rear Fan. Does the Fan's label face inwards? | Go to Step 4. | Correct the installation. |
| 4 | Test the Rear Fan. Run the Service Diagnostics Rear Fan test. Does the fan operate? | Go to Step 6. | Go to Step 5. |
| 5 | Check for +24 V to the fan. Disconnect P/J166. Is there +24 V across P166-1 <=> P166-3? | Replace the Rear Fan (page 8-102). | Replace the LVPS (page 8-99). |
| 6 | Check the fan rotation signal to the LVPS. Print one sheet. Is there +3.3 V between P/J166-1 <=> P/J166-3? | Replace the Fuser Fan (page 8-66). | Go to Step 7. |
| 7 | Check the rotation signal from the LVPS. Print one sheet. Is there +3.3 V between P/J165-15 <=> P/J165-3? | Replace the LVPS (page 8-99). | Go to Step 8. |
| 8 | Check the fan rotation signal at the Engine Control Board. Print one sheet. Is there +3.3 V between P/J61-4 <=> P/J61-16? | Replace the LV Harness | Replace the Engine Control Board (page 8-104). |

Fan Failure

One of the two fans has failed resulting in a fatal error.

Applicable Status Code:

Code 52: This is a generic fan error, generated by the Rear Fan or the Fuser Fan circuit.

Troubleshooting Reference Table

| Applicable Parts | Wiring and Plug/Jack References |
|--|---|
| <ul style="list-style-type: none">■ Rear Fan, PL1.1.19■ Fuser Fan, PL5.3.31 | <ul style="list-style-type: none">■ Print Engine Map 1 - P/J Locator (page 10-5)■ Print Engine Map 2 - P/J Locator (page 10-6)■ Print Engine Drive Wiring (page 10-19)■ Print Engine Power Wiring (page 10-17) |

Troubleshooting Procedure Table

| Step | Actions and Questions | Yes | No |
|------|--|---|---|
| 1 | Check the fans for damage or debris: <ul style="list-style-type: none">■ Fuser Fan, PL1.1.19■ Rear Fan, PL5.3.31 Is either fan damaged? | Replace the defective fan. | Go to Step 3. |
| 2 | Replace the defective fan. Does the error persist? | Go to Step 3 | Complete |
| 3 | Test the fans. Run the Service Diagnostics fan tests to isolate the defective fan. Did one of the fans fail? | Go to the troubleshooting procedure for the specific fan. | If both fans pass, replace the Engine Control Board (page 8-104). |

Fuser Firmware Failure

A failure was detected in the Fuser Firmware.

Applicable Status Code:

Code 76: Fuser Firmware (CRUM) Failure.

Troubleshooting Reference Table

| Applicable Parts | Wiring and Plug/Jack References |
|---|---|
| <ul style="list-style-type: none">■ Fuser, PL5.1.1■ FSR/ADC Harness, PL5.2.28■ Engine Control Board, PL9.1.16 | <ul style="list-style-type: none">■ Print Engine Map 2 - P/J Locator (page 10-6)■ Print Engine Map 3- P/J Locator (page 10-7)■ Print Engine Fuser Wiring (page 10-22) |

Warning

Avoid the potential of electric shock by removing the power cord from the wall outlet prior to performing the following procedure.

Caution

Allow adequate time for the Fuser to cool before servicing the printer.

Troubleshooting Procedure Table

| Step | Actions and Questions | Yes | No |
|------|---|--|----------------------------------|
| 1 | Check the Fuser for damage. Is the Fuser damaged? | Replace the Fuser (page 8-5). | Go to Step 2. |
| 2 | Check the Fuser connection for damage. Any broken or bent pins? | Repair or replace the parts. | Go to Step 3. |
| 3 | Replace the Fuser. Does the error persist? | Go to Step 4. | Complete |
| 4 | Check all pins on the FSR/ADC Harness PL5.2.28 for continuity. 1. Disconnect P/J36 and P/J361. 2. Check continuity between J36 <=> J361. | Replace the Engine Control Board (page 8-104). | Replace the FSR/ ADC Harness. |

Engine Firmware Failure

The Engine Control Board detected a firmware error.

Applicable Status Codes:

Code 70: Fuser Temperature Control Failure

Code 71: Long Cleaning Count Error

Code 74: ASIC Error

Code 78: CRUM Data Error

Code 79: This is a generic Engine Firmware Failure code generated when any other Engine Firmware Failure code fails to report to the controller properly.

Troubleshooting Reference Table

| Applicable Parts | Wiring and Plug/Jack References |
|----------------------------------|---|
| ■ Engine Control Board, PL9.1.16 | ■ Print Engine Map 3- P/J Locator (page 10-7) |

Troubleshooting Procedure Table

| Step | Actions and Questions | Yes | No |
|------|---|--|----------|
| 1 | Does the error persist after the printer power is cycled? | Replace the Engine Control Board (page 8-104). | Complete |

Engine Firmware Failure

The Engine Control Board detected a firmware error.

Applicable Status Codes:

Code 72: NVRAM error

Troubleshooting Reference Table

| Applicable Parts | Wiring and Plug/Jack References |
|----------------------------------|---|
| ■ Engine Control Board, PI9.1.16 | ■ Print Engine Map 3 - P/J Locator (page 10-7) |
| ■ EEPROM Board, PL9.1.12 | ■ Print Engine Xerographics (1/2) Wiring (page 10-24) |

Troubleshooting Procedure Table

| Step | Actions and Questions | Yes | No |
|------|---|--|---|
| 1 | Cycle printer power. Does the error persist? | Go to Step 2. | Complete |
| 2 | Is P/J144 on the EEPROM Board properly seated and defect free? | Go to Step 3. | Reseat P/J144 or replace the EEPROM Board (page 8-103). |
| 3 | Turn printer power off and then back on. Does the error persist? | Replace the Engine Control Board (page 8-104). | Complete |

Engine NVRAM Error

Engine NVRAM is corrupted or receiving corrupt data from a CRUM.

Applicable Status Code:

Code 83: Engine NVRAM Error

Troubleshooting Reference Table

| Applicable Parts | Wiring and Plug/Jack References |
|---|--|
| <ul style="list-style-type: none"> ■ EEPROM Board, PL9.1.12 ■ Imaging Unit, PL6.1.1 ■ Fuser, PL5.1.1 ■ Engine Control Board, PL9.1.16 | <ul style="list-style-type: none"> ■ Print Engine Map 2- P/J Locator (page 10-6) ■ Print Engine Map 3- P/J Locator (page 10-7) ■ Print Engine Xerographics (1./2) Wiring (page 10-24) |

Troubleshooting Procedure Table

| Step | Actions and Questions | Yes | No |
|------|--|---------------|----------|
| 1 | Cycle printer power. Does the error persist? | Go to Step 2. | Complete |
| 2 | Reinstall the Imaging Unit and Fuser. Cycle printer power. Does the error persist? | Go to Step 3. | Complete |
| 3 | Replace the Imaging Unit (page 8-5). Cycle printer power. Does the error persist? | Go to Step 4 | Complete |

Troubleshooting Procedure Table (Continued)

| Step | Actions and Questions | Yes | No |
|------|---|--|----------|
| 4 | Replace the Fuser (page 8-5). Cycle printer power. Does the error persist? | Go to Step 5 | Complete |
| 5 | Replace the EEPROM Board (page 8-103). Cycle printer power. Does the error persist? | Replace the Engine Control Board (page 8-104). | Complete |

[Y] [M] [C] [K] Toner Cartridge Failure

A CRUM error has occurred for the indicated Toner Cartridge.

Applicable Status Codes:

Code 86: Cyan Toner Cartridge Failure

Code 87: Magenta Toner Cartridge Failure.

Code 88: Yellow Toner Cartridge Failure

Code 89: Black Toner Cartridge Failure

Initial Actions:

- Ensure that the Toner Cartridges are fully seated and locked into position.
- Ensure that all ribbon tape has been removed from the cartridges and cycle printer power.
- If the problem persists, follow the procedure below.

Troubleshooting Reference Table

| Applicable Parts | Wiring and Plug/Jack References |
|--|--|
| <ul style="list-style-type: none"> ■ Toner Cartridge, PL7.2.8 ■ RFID Harness, PL7.2.17 ■ RFID2 Harness, PL7.2.16 ■ CRUM Reader, PL7.2.12 | <ul style="list-style-type: none"> ■ Print Engine Map 1 - P/J Locator (page 10-5) ■ Print Engine Developer (1/2) Wiring (page 10-20) |

Troubleshooting Procedure Table

| Step | Actions and Questions | Yes | No |
|------|---|---------------|---------------------------|
| 1 | Check Toner Cartridge installation. Are the Toner Cartridges properly installed? | Go to Step 2. | Correct the installation. |

Troubleshooting Procedure Table (Continued)

| Step | Actions and Questions | Yes | No |
|------|--|--|-------------------------------|
| 2 | Replace the affected Toner Cartridge. Does the error persist after a genuine Xerox Toner Cartridge is installed? | Go to Step 3. | Complete |
| 3 | Check the CRUM Reader connection. Is P/J341 connected to the harness? | Go to Step 4. | Connect the CRUM Reader Board |
| 4 | Replace the CRUM Reader. Does the error persist? | Go to Step 5. | Complete |
| 5 | Check all pins on the RFID2 Harness PL7.2.16 for continuity. 1. Disconnect P/J341 and P/J3411. 2. Check continuity between J341 <=> J3411. | Go to Step 6. | Replace the RFID2 Harness. |
| 6 | Check all pins on the RFID Harness PL7.2.17 for continuity. 1. Disconnect P/J3411 and P/J34. 2. Check continuity between P3411 <=> J34. | Replace the Engine Control Board (page 8-104). | Replace the RFID Harness. |

Environmental Sensor Failure

An error was detected in the Environmental Sensor circuitry.

Applicable Status Code:

Code 102: Environmental Sensor Error

Troubleshooting Reference Table

| Applicable Parts | Wiring and Plug/Jack References |
|---|--|
| <ul style="list-style-type: none"> ■ Temp/Humidity Sensor, PL9.1.20 ■ TMP Harness, PL10.1.4 | <ul style="list-style-type: none"> ■ Print Engine Map 4 - P/J Locator (page 10-8) ■ Print Engine Fuser Wiring (page 10-22) |

Troubleshooting Procedure Table

| Step | Actions and Questions | Yes | No |
|------|---|---------------|---|
| 1 | Test the Temperature/Humidity Sensor. Run the Service Diagnostics Temperature/Humidity Sensor test. Does the sensor function correctly? | Go to Step 2. | Replace the Temp/Hum Sensor (page 8-108). |

Troubleshooting Procedure Table (Continued)

| Step | Actions and Questions | Yes | No |
|------|---|---|--|
| 2 | Check the Humidity signal. Disconnect P/J231. Is the voltage across P/J231-2 <=> P/J231-3 less than +3 V and above +0.5 V. | Go to Step 4. | Go to Step 3. |
| 3 | Check the Temperature signal. Disconnect P/J231. Is the voltage across P/J231-4 <=> P/J231-3 greater than +2.5 V? | Go to Step 4. | Replace the Engine Control Board (page 8-104). |
| 4 | Check for +5 V to the Temperature/ Humidity Sensor. Disconnect P/J231. Is there +5 V across P/J231-1 <=> P/J231-3? | Replace the Temp/ Hum Sensor (page 8-108). | Replace the Engine Control Board (page 8-104). |

Fuser Motor Failure

The Fuser Motor rotation signal indicates that the motor is no longer operational.

Applicable Status Code:

Code 103: Fuser Motor Failure

Initial Actions:

- Ensure that the Fuser is fully seated and locked in position.
- Cycle printer power.
- If the problem persists, follow the procedure below.

Troubleshooting Reference Table

| Applicable Parts | Wiring and Plug/Jack References |
|---|---|
| <ul style="list-style-type: none">■ Fuser Drive Assembly, PL5.2.25■ TNRFULL/FSR Harness, PL5.2.30■ Engine Control Board, PL9.1.16■ Interlock Switch, PL9.1.1 | <ul style="list-style-type: none">■ Print Engine Map 2 - P/J Locator (page 10-6)■ Print Engine Wiring Fuser (page 10-22) |

Warning

Avoid the potential of electric shock by removing the power cord from the wall outlet prior to performing the following procedure.

Caution

Allow adequate time for the Fuser to cool before servicing the printer.

Troubleshooting Procedure Table

| Step | Actions and Questions | Yes | No |
|------|--|--|--|
| 1 | Check the Fuser Drive Assembly for damage. Are any parts of the Fuser Drive Assembly damaged or excessively worn? | Replace the Fuser Drive Assembly (page 8-96). | Go to Step 2. |
| 2 | Check the Fuser Motor connection. Is P/J521 connected to the harness? | Go to Step 3. | Reconnect the Fuser Motor. |
| 3 | Test the Fuser Motor. 1. Close the Interlock Switch while testing. 2. Run the Service Diagnostics Fuser Motor test. Does the motor operate? | Go to Step 5. | Go to Step 4. |
| 4 | Check for +24 V to the Fuser Motor. Is the +24 V across P/J521-10 <=> P/J 521-8? | Go to Step 6. | Go to Step 5. |
| 5 | Test the Interlock Switch. Run the Service Diagnostics Interlock Switch test. Does the switch function correctly? | Go to Step 6. | Replace the Interlock Switch (page 8-101). |
| 6 | Check all pins on the TNRFULL/FSR Harness PL5.2.30 for continuity. 1. Disconnect P/J52 and P/J521. 2. Check continuity between J52 <=> J521. | Replace the Engine Control Board (page 8-104). | Replace the FSR/ADC Harness. |

Developer Motor Failure

The Developer Motor rotation signal indicates that the motor is no longer operational.

Applicable Status Code:

Code 104: Developer Motor Failure

Troubleshooting Reference Table

| Applicable Parts | Wiring and Plug/Jack References |
|--|--|
| <ul style="list-style-type: none"> ■ Developer Drive Assembly, PL8.1.1 ■ Engine Control Board, PL9.1.16 ■ Interlock Switch, PL9.1.11 ■ FAN/PHD/MOT Harness, PL10.1.9 | <ul style="list-style-type: none"> ■ Print Engine Map 2 - P/J Locator (page 10-6) ■ Print Engine Drive Wiring (page 10-19) |

Troubleshooting Procedure Table

| Step | Actions and Questions | Yes | No |
|------|--|--|--|
| 1 | Check the Developer Drive Assembly for damage. Are any parts of the Developer Drive Assembly damaged or excessively worn? | Replace the Developer Drive Assy (page 8-93). | Go to Step 2. |
| 2 | Check the Developer Motor connection. Is P/J491 connected to the harness? | Go to Step 3. | Reconnect the Developer Motor. |
| 3 | Test the Developer Motor. 1. Close the Interlock Switch while testing. 2. Run the Service Diagnostics Developer Motor test. Does the motor operate? | Go to Step 5. | Go to Step 4. |
| 4 | Check for +24 V to the Developer Motor. Is the +24 V across P/J491-1 <=> P/J 481-5? | Go to Step 6. | Go to Step 5. |
| 5 | Test the Interlock Switch. Run the Service Diagnostics Interlock Switch test. Does the switch function correctly? | Go to Step 6. | Replace the Interlock Switch (page 8-101). |
| 6 | Check all pins on the FAN/PHD/MOT Harness PL10.1.9 for continuity. 1. Disconnect P/J48 and P/J491. 2. Check continuity between J48 <=> J491. | Replace the Engine Control Board (page 8-104). | Replace the FAN/PHD/MOT Harness. |

Main Motor Failure

The Main Motor rotation signal indicates that the motor is no longer operational.

Applicable Status Code:

Code 105: Main Motor Failure

Troubleshooting Reference Table

| Applicable Parts | Wiring and Plug/Jack References |
|---|--|
| <ul style="list-style-type: none"> ■ Main Drive Assembly, PL8.1.2 ■ Engine Control Board, PL9.1.16 ■ FAN/PHD/MOT Harness, PL10.1.9 | <ul style="list-style-type: none"> ■ Print Engine Map 2 - P/J Locator (page 10-6) ■ Print Engine Drive Wiring (page 10-19) |

Troubleshooting Procedure Table

| Step | Actions and Questions | Yes | No |
|------|---|--|--|
| 1 | Check the Main Drive Assembly for damage. Are any parts damaged? | Replace the Main Drive Assembly (page 8-95). | Go to Step 2. |
| 2 | Check the Main Motor connection. Is P/J481 connected to the harness? | Go to Step 3. | Reconnect the Main Motor. |
| 3 | Test the Main Motor. 1. Close the Interlock Switch while testing. 2. Run the Service Diagnostics Main Motor test. Does the motor operate? | Go to Step 5. | Go to Step 4. |
| 4 | Check for +24 V to the Main Motor. Is there +24 V across P/J481-10 <=> P/J 481-8? | Go to Step 6. | Go to Step 5. |
| 5 | Test the Interlock Switch. Run the Service Diagnostics Interlock Switch test. Does the switch function correctly? | Go to Step 6. | Replace the Interlock Switch (page 8-101). |
| 6 | Check all pins on the FAN/PHD/MOT Harness, PL10.1.9 for continuity. 1. Disconnect P/J48 and P/J481. 2. Check continuity between J48 <=> J481. | Replace the Engine Control Board (page 8-104). | Replace the FAN/PHD/MOT Harness. |

Motor Failure

One of the primary drive motors has failed.

Applicable Status Code:

Code 106: Motor Failure

Troubleshooting Reference Table

| Applicable Parts | Wiring and Plug/Jack References |
|---|--|
| <ul style="list-style-type: none"> ■ Main Drive Assembly, PL8.1.2 ■ Developer Drive Assembly, PL8.1.1 ■ Fuser Drive Assembly, PL5.2.25 ■ Engine Control Board, PL9.1.16 ■ Interlock Switch, PL9.1.11 | <ul style="list-style-type: none"> ■ Print Engine Map 2 - P/J Locator (page 10-6) ■ Print Engine Drive Wiring (page 10-19) ■ Print Engine Wiring Fuser (page 10-22) |

Troubleshooting Procedure Table

| Step | Actions and Questions | Yes | No |
|------|--|--------------------|--|
| 1 | Check the motors. Run the Service Diagnostics motor tests to determine the failed part. Is the failed part the Main Drive Motor? | Go to (page 3-81). | Test the Fuser Motor. |
| 2 | Is the failed part the Fuser Drive Motor? | Go to (page 3-82). | Test the Developer Motor. |
| 3 | Is the failed part the Developer Drive Motor? | Go to (page 3-82). | Replace the Engine Control Board (page 8-104). |

Disk Failure

An error was detected in the Hard Disk.

Applicable Status Code:

Code 80: Disk Failure

Initial Actions:

- Cycle the printer's power.
- If the problem persists follow the procedure below.

Troubleshooting Reference Table

| Applicable Parts | Wiring and Plug/Jack References |
|--|---------------------------------|
| <ul style="list-style-type: none"> ■ Hard Drive PL9.1.25 ■ Image Processor Board PL9.1.3 | |

Troubleshooting Procedure Table

| Step | Actions and Questions | Yes | No |
|------|---|---|---------------------------|
| 1 | Check the Hard Drive installation. Is the Hard Drive properly installed? | Go to Step 2. | Correct the installation. |
| 2 | Replace the Internal Hard Drive. Does the error persist? | Replace the Image Processor Board (page 8-98) | Complete |

Image Density Failure

The engine detected a low-density image condition.

Applicable Status Code:

Code 77: Low Density Failure

Initial Actions:

- Ensure the Transfer Roller and surrounding area is free of waste toner.
- Clean the CTD (ADC) Sensor.
- Cycle the printer's power.
- If the problem persists follow the procedure below.

Troubleshooting Reference Table

| Applicable Parts | Wiring and Plug/Jack References |
|---|--|
| <ul style="list-style-type: none">■ Transfer Roller, PL5.1.4■ CTD (ADC) Sensor PL5.2.19■ Engine Control Board PL9.1.16■ FSR/ADC Harness PL5.2.28 | <ul style="list-style-type: none">■ Print Engine Map 2 - P/J Locator (page 10-6)■ Print Engine Xerographics (1/2) (page 10-24)■ Print Engine Xerographics (2/2) (page 10-25) |

Troubleshooting Procedure Table

| Step | Actions and Questions | Yes | No |
|------|--|---|-------------------------------------|
| 1 | Clean the CTD (ADC) Sensor. Does the error persist? | Go to Step 2. | Complete |
| 2 | Check the following for evidence of fault or damage: Transfer Roller Assembly, PL5.1.4 CTD (ADC) Sensor, PL5.2.19 | Replace any damaged parts. | Go to Step 3. |
| 3 | Check the CTD (ADC) Sensor connector. Is P/J136 connected to the harness? | Go to Step 4. | Reseat the connector to the sensor. |
| 4 | Replace the CTD (ADC) Sensor. Does the error persist? | Go to Step 5. | Complete |
| 5 | Check all pins on the FSR/ADC Harness PL5.2.28 for continuity. 1. Disconnect P/J36 and P/J136 2. Check continuity between J36 <=> J136 | Replace the Engine Control Board (page 8-104) | Replace the FSR/ADC Harness. |

General Troubleshooting

In this chapter...

- Power On Self Test (POST)
- Service Diagnostics
- Control Panel Troubleshooting
- Inoperable Printer Troubleshooting
- AC Power Supply Troubleshooting
- DC Power Supply Troubleshooting
- Media Jams and the Paper Path
- Operating System and Application Problems
- Network Problems

Section

4



Introduction

This section covers the start-up, Power On Self Test (POST), Service Diagnostics, and power supply operations of the printer to aid in troubleshooting problems not associated with a reported error. For problems associated with an error message or code, see "Error Messages and Codes" on page 3-1. Troubleshooting tips are available at: www.xerox.com/office/6300_6350support.

Troubleshooting procedures isolate a problem to a specific component or subassembly. If you go through the procedures and are still unable to solve the problem, re-read the "Theory of Operation" section for the problem area to understand how that section of the printer functions.

System Startup

Listed here is a typical startup routine from a cold start. The printer requires approximately 45 seconds to complete this sequence.

1. When the power switch is turned On, the 'Health' LED on the Image Processor Board turns on immediately.
2. System RAM is tested. If an error is detected, RAM ERROR displays and one or both of the Control Panel and Health LEDs alternately blink at 1/2 second intervals.
3. The Boot Loader then loads and runs POST diagnostics.
4. POST turns off the Health LED.
5. POST checks the Control Panel.
6. POST checks the keypad buffer. If a shortcut has been selected, the printer displays Processing Input and the shortcut executes. If a random button is pushed, or there is an indication of a button press, Processing Input displays and POST continues. If no buttons have been pushed, POST continues execution.
7. The display is reset (addressable area turns "Gray").
8. The Control Panel LED cycles: Green, Yellow, Red, and then off.
9. The display backlight turns on (high intensity), with nominal contrast display.
10. The display area is turned on, dark Black for 1 second.
11. The display is cleared.
12. The display backlight turns on with nominal intensity.
13. The POST Vn.nn message displays, and tests are quickly executed.
14. For Hard Faults, the display indicates the last test run and "CALL SERVICE".
15. After the POST tests have successfully finished, the Xerox 'splash screen' displays on the Control Panel and PostScript begins initialization.
16. The Control Panel LED turns Green and the display reads Warming up - Please wait.
17. The Control Panel LED turns Green and the display reads Ready to Print.

Power On Self Test (POST)

POST diagnostics provide a quick means of isolating a defective subsystem associated with the Image Processor Board and SDRAM. There are two kinds of POST faults: soft and hard. A soft fault is any fault that allows the operating system to initialize. Soft faults do not stop printer operation and are reported on the Startup page after the system is running. A hard fault prevents the operating system from initializing stopping further printer operation. Hard faults are indicated with blinking LEDs and the failed test appearing on the display.

The following tests execute when the printer is powered on after the Boot Loader runs, and before the operating system is loaded and initialized. Bypass POST by pressing the **OK** button at power on until the splash screen displays.

POST Test Descriptions

| Test | Fault Code | Fault Type | Description |
|-----------------|------------|------------|--|
| SDRAM | 1 | Hard | This test fails if the boot loader finds no or faulty RAM (Run prior to POST.). The boot loader displays "RAM ERROR" and blinks the Health and Control Panel LEDs. |
| Control Panel | | Hard | This test checks the Control Panel connection and firmware. A fault is indicated on the Health LED. |
| Extended Memory | 7 | | This test does a write compare test to each 32-bit word in extended memory. |
| EEPROM | 10 | Hard | This test checks addressing of the EEPROM. |
| Ethernet | 11 | Soft | This test checks the ethernet core. |
| CPU Interrupts | 12 | Hard | This test checks that each interrupt to the CPU is functioning. |
| USB | 13 | Soft | This test checks that the USB core is functioning properly. |
| Real-Time Clock | 14 | Soft | The real-time clock is tested. |
| RAM DIMM | 15 | Soft | This test checks RAM compatibility. |
| Min. RAM | 16 | Hard | Checks that there is at least 128 Mbytes installed. Control Panel displays "Install More RAM" on failure. |
| Max. RAM | 17 | Soft | Checks that there is no more than 1 GB installed. |
| IDE Disk | 20 | Soft | Checks for a hard drive, then checks the disk controller core. |
| Engine Command | 22 | Hard | Checks communications between the Engine Control and Image Processor boards. |

POST Soft Fault Messages

When POST detects a soft error, the printer continues the startup process. Before the printer reaches its “Ready” state, the Startup page is printed with soft errors appearing in a red box. The box contains all soft faults encountered, with the upper left corner of the box in the center of the Startup page, and extending to the right margin, similar to the one shown here.

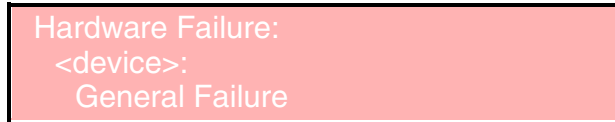

Hardware Failure:
<device>:
General Failure

These messages are substituted for <device>:

- Ethernet
- USB
- Real-Time Clock
- RAM Memory Slot 1 Checksum
- RAM Memory Slot 2 Checksum
- RAM Memory Slot 1 Rejected
- RAM Memory Slot 2 Rejected
- Max RAM Limit
- IDE Disk

For Ethernet, USB, and Real-Time Clock errors, replace the Image Processor Board. For IDE Disk errors, replace the Hard Drive. For memory errors, see "RAM Memory Fault Isolation" on page 4-16.

POST Hard Fault Messages

POST indicates a hard fault by displaying a message on the Control Panel and blinking the fault code on the health and Control Panel LEDs. There are long and short blinks. A long blink is worth 5 and a short blink is worth 1. As an example, a blink pattern flashed as long, long, short, short, represents fault code 5+5+1+1=12, indicating a failure in the CPU interrupt test. Along with the blinking LEDs, the failed test also displays as:

**POWER ON SELF TEST ERROR
12:CPU INTERRUPTS
CALL SERVICE SUPPORT**

The exception to this reporting scheme is a RAM test error. The Boot Loader executes a RAM test prior to loading POST. If the Boot Loader encounters a RAM error, POST does not load.

Hard Error LED Blink Patterns and Messages

| LED Blink Pattern | Control Panel Message | Action |
|-------------------|-----------------------|---|
| 1 | RAM ERROR | No RAM present, or faulty RAM. Alternate 1/2 second interval blink at Control Panel and Health LEDs if the controller has initialized the FPGA. Otherwise, only the Health LED blinks. |
| 1+1 | | Control Panel disconnected or defective. |
| 5+5 | 10: EEPROM | <ol style="list-style-type: none">1. Switch Off printer power.2. Remove and re-install the NVRAM EEPROM.3. Switch On printer power.4. If the error message persists, replace NVRAM , and then the Image Processor Board. |
| 5+5+1+1 | 12: CPU INTERRUPTS | Replace Image Processor Board (page 8-98). |
| 5+5+5+1 | 16: Min RAM | Add additional RAM memory. |
| 5+5+5+5+1+1 | 22: Engine Command | If a failure is detected, Reseat Controller Board is displayed (page 4-12). |

Fault Isolation

Isolate a fault to the print engine or Image Processor Board by printing an Engine Test Print (page 5-9).

- If the printer successfully prints the Print Engine Test Print, replace the Image Processor Board (page 8-98).
- If the Printer fails to print the Print Engine Test Print, troubleshoot the print engine starting with the AC power supply on (page 4-14).

Service Diagnostics

Service Diagnostics provides tests for most electro-mechanical components in the printer. Service Diagnostics also contains test prints, printer status and some NVRAM access. If confronted with an error that requires more than a cursory investigation to clear or when directed by a troubleshooting procedure, use Service Diagnostics to exercise selected sub-assemblies of parts in the vicinity of the reported error. Tests are controlled from the Control Panel and are described in detail in the Appendix.

The Service Diagnostics Main menu offers the options listed in the following table.

Service Diagnostics Main Menu

| Menu Item | Test Target |
|---------------------------|---|
| Print Service Menu Map | Prints the Service Diagnostics menu map. |
| General Status | Query information about the status, versions, and counts. |
| Test Prints | Isolate problems with Xerographics and paper handling. |
| Motors/Fan Tests | These tests exercise each motor or fan. |
| Sensor/Switch Test | Tests sensor status and operation. |
| Clutch Tests | Tests clutch function. |
| Solenoid Tests | Tests solenoid function. |
| Maintenance | Clean the IDT rollers in the Imaging Unit. |
| NVRAM Access | Reset PostScript or all NVRAM. |
| IP Controller Diagnostics | Tests the Image Processor Board. |
| Exit | Exits Service Diagnostics and reboots the printer. |

Using Service Diagnostics

The printer's operating system monitors sensors located throughout the print engine and attached options. Sensor signals are used to monitor paper handling and mechanical activity along the entire paper path. As a sheet travels along the paper path, sensors change state temporarily to indicate the sheet's presence. If the pattern of sensor state changes differs from the expected timing for a particular paper size and path, the sensor where the timing difference occurs identifies the error to report.

However, having the error message information doesn't necessarily pinpoint the problem. Sensor signals locate where, but often cannot identify why. Motors, belts, gears, solenoids, and numerous other parts are involved in paper transport. The Service Diagnostics' suite of tests and utilities are the best tools available to pinpoint the root cause behind the reported error.

Access Service Diagnostics one of two ways:

Entering Diagnostics Without Rebooting the Printer:

1. On the Control panel, select **Troubleshooting**, and then press the **OK** button.
2. Select **Service Tools**, and then press the **OK** button.
3. Hold down both the **Up Arrow** and **Down Arrow** buttons for about three seconds. When the **Hidden Service** menu displays, scroll to **Run Service Diagnostics**, and then press the **OK** button.

Entering Diagnostics by Rebooting the Printer:

1. Turn the printer power Off.
2. Hold down the **Back** and **Help (?)** buttons simultaneously and turn the printer On.
3. Continue to hold the buttons until “Entering Service Diagnostics” is displayed.

During initialization, Service Diagnostics checks communication between the Engine Control and Image Processor Boards. This communications test may take as long as 90 seconds to complete. During this period, the version of Service Diagnostics and the string **Initializing...** is displayed. Following successful completion of the test, the Service Diagnostics menu displays.

If an error is detected during this test, **22:Reseat Controller Board** and **Call Customer Support** display. In this event, see (page 4-12).

Print a Service Diagnostics Menu Map by selecting **Print Service Menu Map**, and then pressing the **OK** button. The printer executes POST and returns to Ready. You will need to re-enter Service Diagnostics. For convenience, the Service Diagnostics Menu Map is reproduced on page A-10.

Service Diagnostics Controls

Use the Control Panel buttons to interact with Service Diagnostics’ tests and utilities.

| Button | Function |
|-------------------|--|
| Back | Returns to the prior higher level menu structure, if available. If help text is displayed, pressing Back restores the current menu item. |
| Cancel | Terminates the current test or cancels current Help (?) display. |
| Help (?) | Provides help information, if available. Pressing Help (?) again restores the current menu item and removes the help text. |
| Up Arrow | Scrolls up one menu item within a menu list. This control does not ‘wrap’. Used to increment data in tests requiring user input. |
| Down Arrow | Scrolls down one menu item within a menu list. This control does not ‘wrap’, the end of a menu list is designated by three asterisks. Used to decrement data in tests requiring user input. |
| OK | Enters the highlighted menu. Executes the current test item. Used to select a data value entered by the user. |

Control Panel Shortcuts

The following are Control Panel button sequences that provide shortcuts to specific commands when pressed while turning On the printer's power.

| Mode | Buttons Pressed at Power On |
|------------------------------------|------------------------------|
| Skip POST Diagnostics | OK |
| Print Service Diagnostics Menu Map | Help (?) |
| Reset PostScript NVRAM | Back + OK |
| Password Bypass | Up Arrow + Down Arrow |
| Enter Service Diagnostics | Back + Help (?) |
| Control Panel Language | Cancel + Help (?) |

Note

The best method of exiting Service Diagnostics is to cycle printer power. This insures all printer components are reset. Also, an occasional paper jam is normal on the first print if clutch or solenoid tests were run.

Hidden Service Menu

The Hidden Service menu includes a list of functions providing direct access to Service Diagnostics, the Developer Assembly counters, and the Enable Metered Toner routine. Access the Hidden Service menu as follows:

1. Highlight **Troubleshooting** --> **Service Tools**.
2. With the cursor at the top of the **Service Tools** menu, press both the **Up Arrow** and **Down Arrow** buttons.

Service Diagnostics Utilities

Three Service Diagnostics utilities are especially useful for troubleshooting:

- Status
- Test Prints
- Diagnostic Fault History

What follows is an overview that describes the function and proper application of the each utility.

Status

Located in the General Status menu, Status reports on the condition of the printer. Status reports either No Status to Report, or sequentially lists error conditions occurring since power-up. Conditions that prevent printing are listed before warnings. Status listings are not stored. If the printer reaches Ready, the list is cleared. Some applications of status are:

- Provides an initial condition from boot to begin troubleshooting.
- Captures static or dynamic events.
- Confirms diagnostic test results and subsequent repairs.

Test Prints

Test Prints can isolate printing problems to the Engine Control or Image Processor Board by eliminating image data transfer between the two. Test Prints does not exercise any Image Processor Board circuitry. Test Prints gets its image data from ROM. This allows the examination of Engine Control Board function in isolation.

Test Prints is also useful for stimulating asynchronous (dynamic) events related to the print process, or as a test for paper path and media related problems. Some other key features of Test Prints:

- Is the only diagnostic utility to exercise the entire print cycle.
- Isolated from the operating system (PostScript). Runs from firmware.
- Isolates the Image Processor Board from Engine Control Board.
- Captures static or dynamic events.
- Helps to isolate events that cause print artifacts or prevents printing.

Diagnostic Fault History

The Diagnostic Fault History utility records a list of engine-generated error events, warnings are not captured, that occur during diagnostic testing. Use this utility to record error events that occur while executing tests in Diagnostic Mode. The Diagnostic Fault History utility captures asynchronous (transient) events only. For static (continuous), or pre-existing events, rely on the Status utility.

When executed from the Service Diagnostics General Status menu, the Diagnostic Fault History displays on the Control Panel and updates as each error event is detected. Fault History events are recorded only when no pre-existing errors are present. The second and subsequent occurrences of the same event are not recorded. The maximum number of events recorded is 25. Once the list is full, additional new events are lost until the log is cleared by either a printer reboot or by selecting Fault History Master Clear from the Fault History menu. New events occurring after the list is cleared are recorded.

For display, the list combines a line number, a code, and potentially a test precondition indicated by the letter **P** (for events requiring a power cycle), a **U** for unknown event sequence, an **M** for more entries, or a string of asterisks ********* to indicate the last error recorded.

As an example:

```
<Fault History Display>
1 [150]
2 [42]P
3 [198]P
4 [T2]M
Press CANCEL to exit
```

The example shows a single screen displaying four events. Lines 2 and 3 include the precondition indicator **P** directing a reboot before component testing continues. Line 4 includes an abbreviated Misfeed at Tray 2 code, and the continuation notation **M** indicating more events appear on subsequent pages. Pressing **OK** calls up the next page. Pressing **Cancel** exits the utility and displays the Fault History menu.

Note

Jam codes are abbreviated for display. The word “Jam” is removed from the code leaving only the location designator (F, D, RR, T1~5).

Events typically appear in the order detected. However, occasionally the event’s sequence is indeterminate. As is the case with simultaneous events. In these cases, a **U** is appended to the event to indicate an unknown sequence. While event sequence can be important in determining cause, the event itself provides a starting point for investigation.

For those events listed with a **P**, testing of a specific component may not require the indicated power cycle. For example, if the log lists a motor failure, it’s reasonable to go directly to the appropriate motor test to confirm the failure without first power cycling the printer. For events involving components, such as the Fuser, Transfer Roller, or Toner Cartridges, power cycling is recommended before additional testing is performed.

Using Diagnostic Fault History

The general approach to using the Diagnostic Fault History utility is as follows:

1. Determine the diagnostic test necessary to reproduce a suspected transient event.
2. Determine if the current logged events are important to understanding the problem. If so, examine or record the events currently in the log, perform whatever analysis is appropriate, and then clear the log.
3. Perform the selected test.
4. Re-examine the event list.
5. Identify an abnormal or suspicious event based on the test performed. For example, a door open event while printing a test print when the door remained closed.

As an example, assume the Interlock Switch is suspect. The process to gain access to the switch will produce a number of events unrelated to switch function. Therefore, you would:

1. Override the interlock function to provide power.
2. Access to the Interlock Switch actuator.
3. Clear the list with **Fault History Master Clear**.
4. Restart Diagnostic Fault History and manipulate the component or connecting wires as required to reveal the switch's condition.

Control Panel Troubleshooting

No Control Panel Display after Power Is Turned On

1. Remove and reseal the Image Processor Board (page 8-98).
2. Print an Engine Test Print (page 5-9).
3. Replace the Image Processor Board (page 8-98) (if Step 2 passes).
4. See "DC Power Supply Troubleshooting" on (page 4-14).
5. Replace the Control Panel (page 8-11).
6. Replace the Control Panel wiring harness (page 8-11).

Control Panel LED Is On, Control Panel Display Is Blank

1. Remove and reseal the Image Processor Board (page 8-98).
2. Replace the Control Panel (page 8-11).
3. Replace the Control Panel wiring harness.
4. Replace the Image Processor Board (page 8-98).

Inoperable Printer Troubleshooting

Engine Power-Up Sequence

1. Engine Control Board logic check
2. Imaging Unit (Missing, NVRAM (CRUM) Error, CRUM ID, Life Over)
3. Fuser (Missing, NVRAM (CRUM) Error, Life Over)
4. Toner Cartridge (Missing, Life Over)
5. Transfer Roller (Missing, Life Over)
6. CTD (ADC) Sensor (Error)
7. All paper sensor (Jam)
8. Door(s) (Open)
9. Environment Sensor (Error)
10. NVRAM (NVRAM error)
11. Image Processor Board POST Diagnostic check

Printer Continually Displays Warming Up...

1. Verify the correct Fuser (110 V vs 220 V) is installed in the printer.
2. See the Engine Power-Up Sequence on (page 4-12).

Printer Continually Displays Install or Reseat Imaging Unit

1. See “Install or Reseat Imaging Unit” on page 3-33.

Printer Displays Reseat Controller Board

1. Turn Off printer power.
2. Remove the Image Processor Board (page 8-98).
3. Check the condition of (P/J120). Reseat the Image Processor Board and completely tighten the screws that secure the Rear Panel to the frame.
4. Reboot the printer. If the error persists, turn Off printer power and verify the 3.3 VDC supplied from the LVPS. See "DC Power Supply Troubleshooting" on page 4-14.
5. Reboot the printer. If the error persists, turn Off printer power and replace the Image Processor Board (page 8-98).
6. Reboot the printer. If the error persists, turn Off printer power and replace the Engine Control Board (page 8-104).

Printer Does Not Come to a Ready State

- See “AC Power Supply Troubleshooting” on (page 4-14).
- See "Fault Isolation" on (page 4-5).

Paper Size Switch Assembly

Paper size and tray presence is detected by the state of the upper, middle, and lower switches of the Paper Size Switch. A failed or jammed switch effects the printer’s ability to accurately detect paper size or the presence of the paper tray.

| Paper Size | Switches | | |
|---|----------|--------|-------|
| | Upper | Middle | Lower |
| Legal 14" | On | On | On |
| US Folio (Legal 13)" | On | On | Off |
| Executive | On | Off | On |
| B5 | On | Off | Off |
| A4 | Off | On | On |
| A5 (for reference, supported in Tray 1(MPT) only) | Off | On | Off |
| Letter | Off | Off | On |
| No Tray | Off | Off | Off |

Power Supply

LVPS Overcurrent Protection Circuit

This circuit stops all outputs if the 24 VDC, 5 VDC or 3.3 VDC power supply is shorted. The circuit is reset when the short is removed, the power is turned off, and then on again.

Note

The 5V supply to the Image Processor Board is excluded. This circuit is protected by a fuse (F101) which if blown, must be replaced.

LVPS Overvoltage Protection Circuit

This circuit stops all outputs if the 24 VDC, 5 VDC or 3.3 VDC power supply exceeds the specified voltage. The operating point is 32 VDC or more for 24 VDC, 7 VDC or more for 5 VDC, or 6 VDC or more for 3.3 VDC.

Note

The circuit resets after a short period of time after the printer power is cycled.

Fan Output Circuit

For the Fan Rear On(H) signal, the output voltage varies depending on the status of FAN LOW signal and FanStop signal from the Fan Control circuit on the LVPS (refer to "Power" on page 10-17).

+24 VDC Output Stopped By Interlock Switch

Opening Door A or B opens the Interlock Switch. This shuts off the +24 VDC supplied to the motors, clutches, and solenoids.

AC Power Supply Troubleshooting

Troubleshooting Reference Table

| Applicable Parts | Wiring and Plug/Jack References |
|------------------|--|
| ■ LVPS, PL9.1.6 | ■ Print Engine Power Wiring Diagram (page 10-17) |

Troubleshooting Procedure Table

| Step | Action and Questions | Yes | No |
|------|--|-----------------------------------|--|
| 1 | Check the voltage at the AC wall outlet. Is there approximately 110 VAC (or 220 VAC if the printer is a 220 V configuration) at the AC wall outlet? | Go to Step 2. | Notify the customer of improper AC output from the outlet. |
| 2 | Check the power cord for defects or a loose connection. | Replace or reseal the power cord. | Replace the LVPS (page 8-99). |

DC Power Supply Troubleshooting

Troubleshooting Reference Table

| Applicable Parts | Wiring and Plug/Jack References |
|------------------|--|
| ■ LVPS, PL9.1.6 | ■ Print Engine LVPS and Drive P/J Locator (page 10-6) ■ Print Engine Power Wiring Diagram (page 10-17). |

Troubleshooting Procedure Table

| Step | Action and Questions | Yes | No |
|------|--|----------------------------------|-------------------------------|
| 1 | Perform the AC power supply troubleshooting procedure. Does the problem persist? | Go to Step 2. | Complete |
| 2 | Turn the AC power Switch Off. Is the fuse (F101) on the low-voltage power supply board open? | Replace the LVPS (page 8-99). | Go to Step 3. |
| 3 | 1. Disconnect the connectors J163, J164 and J165 from the LVPS. 2. Turn the AC power switch On. 3. Verify the DC voltages between the following pins on the LVPS: P163-1 <=> P163-2 = +24 VDC? P164-1 <=> P164-4 = +3.3 VDC? P165-2 <=> P165-3 = +5 VDC? P165-4 <=> P165-5 = +3.3 VDC? | Go to Step 4. | Replace the LVPS (page 8-99). |
| 4 | 1. Turn the AC power switch Off. 2. Connect J164 to the LVPS then turn the AC power switch On. P/J164-1 <=>P/J164-4 = +3.3 VDC? | Go to Step 7. | Go to Step 5. |
| 5 | Check the following parts for fault or damage: ■ LVRPG Harness, PL10.1.3. ■ Engine Control Board, PL9.1.16 | Replace if damaged or defective. | Go to Step 7. |
| 6 | Does the problem recur? | Go to Step 7 | Complete |
| 7 | 1. Turn the AC power switch Off. 2. Connect J165 to the LVPS then turn the AC power switch On. 3. Verify the DC voltages between the following pins on the LVPS: P/J165-2 <=> P/J165-3 = +5 VDC? P/J165-3 <=> P/J165-4 = +3.3 VDC? | Go to Step 10. | Go to Step 8. |
| 8 | Check the LV Harness, PL10.1.2 for fault or damage. | Replace if damaged or defective. | Go to Step 10. |
| 9 | Does the error recur? | Go to Step 10. | Complete |
| 10 | Turn the AC power Switch OFF Connect J163 to the LVPS then turn the AC power switch ON. P/J163-1 <->P/J163-2 = +24 VDC? | Complete | Go to Step 11. |
| 11 | Check the 24V Harness, PL10.1.1 for fault or damage. | Replace if damaged or defective. | Complete |

RAM Memory Fault Isolation

Image Processor Board RAM memory has failed or is not installed. A minimum of 256 MB of RAM must be installed for proper printer operation. The Phaser 6300/6350 Color Laser Printer supports DDR PC2700 in 200-pin SODIMM form. The printer accepts modules of 256 or 512 MB in combinations up to 1 GB.

Errors appearing on the Startup page:

Hardware Failure: RAM Memory Slot 1 Checksum

Hardware Failure: RAM Memory Slot 2 Checksum

Hardware Failure: RAM Memory Slot 1 Rejected

Hardware Failure: RAM Memory Slot 2 Rejected

Errors appearing on the Control Panel:

Power On Self Test Error 15: RAM DIMM

Power On Self Test Error 16: Minimum RAM Limit

Power On Self Test Error RAM ERROR

Initial Actions:

Check that the RAM devices are making positive contact with their connectors.

1. Power off the printer.
2. Remove and re-install the RAM memory after verifying it meets the Xerox specifications. See "Memory Specifications" on page 1-12. If the problem persists, use the following procedure to correct it.

Troubleshooting Reference Table

| Applicable Parts | Wiring and Plug/Jack References |
|---|---|
| <ul style="list-style-type: none">■ SDRAM Memory, PL9.1.26■ Image Processor Board, PL9.1.3 | <ul style="list-style-type: none">■ Print Engine Map 3- P/J Locator (page 10-7) |

Troubleshooting Procedure Table

| Step | Action and Questions | Yes | No |
|------|---|---------------|---------------|
| 1 | Power on the printer. Is RAM ERROR displayed on the Control Panel? | Go to Step 5. | Go to Step 2. |

Troubleshooting Procedure Table (Continued)

| Step | Action and Questions | Yes | No |
|----------|---|------------------------------------|------------------------------------|
| 2 | Is 15: RAM DIMM displayed on the Control Panel? | Go to Step 5. | Go to Step 3. |
| 3 | Is 16: Min RAM Limit displayed on the Control Panel? | Go to Step 5. | Go to Step 4. |
| 4 | Print a Startup Page and review the contents. Does the Startup Page identify a failed memory DIMM? | Replace the DIMM and go to Step 9. | Go to Step 5. |
| 5 | Are there two DIMMs installed in the printer? | Go to Step 6. | Go to Step 8. |
| 6 | Determine Memory condition. 1. Power off the printer and remove one of the DIMMs. 2. Power on the printer. Is a memory fault message displayed? | Go to Step 8. | Go to Step 7. |
| 7 | 1. Power off the printer and remove the first DIMM. 2. Install the second DIMM and power on the printer. Is a memory fault message displayed? | Go to Step 8. | Go to Step 9. |
| 8 | 1. Power off the printer and move the suspected defective DIMM to the other memory socket. 2. Power on the printer. Does the DIMM fail in the new location? | Replace the DIMM and go to Step 9. | Replace the I/P board (page 8-98). |
| 9 | Install all of the DIMMs and power on the printer. Is a memory fault message displayed? | Replace the I/P board (page 8-98). | Complete |

Media Jams and the Paper Path

Media-Based Problems

1. Check that the correct type of media is being used; for the correct media types and weights, see "Media Specifications" on page 1-17. The customer should be using a quality laser printer paper. The printer may have trouble picking glossy or overly smooth paper.
2. Only Phaser 25-Series Premium Transparency Film can be used in this printer.
3. Inspect the paper for bent, torn, or folded corners.
4. Check the paper path for obstructions or debris.
5. Ensure that the correct media type is set in the Control Panel.
6. Ensure that the paper guides are set correctly.
7. Ensure that the media is a supported type for the tray. See "Media and Tray Specifications" on page 1-17, for the correct media types, sizes and weights for each tray.
8. Load a fresh ream of paper in the tray.

Multiple-Sheet Pick

1. Ensure that the paper is in good condition and is listed on the Paper Tips page as supported media; quality office laser printer paper works best.
2. Ensure that the printer is printing within its environmental specifications by printing and reviewing the Status page.
3. Remove the tray and remove, fan, and reload the media. Ensure that the guides are securely against the paper and the tray has not been over filled.
4. Try loading paper from a fresh ream, fan the paper, and then insert into the tray or flip existing paper over.
5. Check the tray's Retard Roller for damage.
6. Clean the Feed Rollers with a clean, dry, lint-free wipe.
7. Replace the Feed Rollers.
8. Replace the paper tray.

Mis-Pick

1. Check that the correct type of media for the tray is being used and the paper guides are set correctly.
2. Remove, fan, and reload the media. Ensure that the tray has not been over filled.
3. Try loading paper from a fresh ream, fan the paper, and then insert into the tray or flip existing paper over.
4. Clean the Feed Rollers with a clean, dry, lint-free wipe.
5. Troubleshoot the Paper Pick Assembly.

Skewed Image

1. The image area is not parallel “Skewed” with the sides of the page but the printer neither jams nor displays an error code.
2. Remove the tray and ensure the paper guides are set correctly.
3. Check that the correct type of media for the tray is being used.
4. Ensure that the tray has not been over filled. (Skewed images are a common defect when Tray 1 (MPT) is overfilled.)
5. Verify the Feed Rollers are installed correctly.
6. Clean the Feed Rollers with a clean, dry, lint-free wipe.
7. Troubleshoot the Paper Pick Assembly.

Damaged Prints

The printed page exits the printer either wrinkled, creased, or torn. The printer neither jams nor displays an error code.

1. Stop the page at various points in the paper path to determine where the media becomes damaged. See “Paper Path Route” on page 2-17 for more information.
2. Try using the next heaviest type of paper. For more information print the Paper Tips Page from the printer’s Information Pages menu.
3. Feed paper through the printer from each of the available trays. Is the paper damaged when fed out of one tray but not when fed out of the others? If so, inspect the tray for damage, ensure that the media guides are set correctly and verify that the proper media is being used.
4. If media shows damage from all trays, check for a problem in Registration Roller Assembly area.
5. Inspect the paper tray and path for debris or broken components.

Fuser Jams

1. Check that the Fuser is properly seated, locked, and operates normally.
2. Ensure that the paper is in good condition and is listed on the Paper Tips page as supported media. Try loading new media from a fresh ream.
3. Ensure that only supported transparency film is being used.
4. Check that the printer is operating within its environmental specifications by using the Printer Status Page.
5. Ensure that the loaded media matches the Control Panel settings.
6. Are the margins on the page greater than 5 mm?
7. Check the Fuser area for debris.
8. Visually inspect the Fuser baffle for burrs.
9. Test the Fuser Motor using Service Diagnostics.
10. See “Jam at Fuser Jam F” on page 3-11 for troubleshooting Fuser Jams.

Exit Jams

1. Ensure the paper is in good condition and is the correct type for the printer. See “Media and Tray Specifications” on page 1-17 for the correct media types, sizes and weights for each tray.
2. Ensure the printer is within its operating environmental specifications.
3. If media is showing excessive curl when exiting, try turning the media over, loading new media from a fresh ream, or a different type of media.
4. Ensure that the loaded media matches the Control Panel settings.
5. Is the jam caused by a heavy, stiff paper being used for two-sided printing? In such cases, a lighter grade of paper should be used, see the printer’s Paper Tips page.
6. Clean all exit locations in the Fuser and the Chute Assembly, with a clean, dry, lint-free wipe, if debris is visible.
7. Does the Exit Roller turn? Test the Duplex Motor using Service Diagnostics. For information on Service Diagnostics, see "Service Diagnostics" on page 4-6.
8. See “Jam at Duplex Jam D” on page 3-13 for troubleshooting duplex jams if the Duplex Motor test fails.

Operating System and Application Problems

Print a Status page to ensure the problem is not printer related. See "Status Page" on page 3-3. Troubleshooting tips and additional information are also available on the Xerox web site at: www.xerox.com/office/6300_6350support.

Macintosh Printing Problems

Image Never Prints

Note

The following steps are for diagnosing a networked printer running Mac OS X, version 10.2.6 or later, and assume that CentreWare® access is enabled. If you are using Mac OS X, but an earlier version than 10.2.6, upgrade first.

1. Cycle power to the printer Off and On, and then try printing again.
2. Determine the printer’s IP address from the Control Panel or Startup page. Return the Control Panel to the initial menu, and then check to make sure it indicates Ready to Print. If it does not indicate Ready to Print, correct that first.

3. Make sure you can connect to the printer via network from the host: Open a Safari or Internet Explorer window to the printer IP address. Once you have established basic network connectivity, proceed to Step 4.
 - a. If you can not see the CentreWare IS page from the printer CentreWare IS web server, the printer may be Off, on a different network, or the host is not networked correctly. Try Steps b through f to correct the problem. If you make any changes to the network, try printing the job again.
 - b. Open **System Preferences**, select **Network**, and select the **TCP/IP** tab. Make sure you have a valid IP address. Correct the settings and retry if needed.
 - c. If you are on a network with a proxy server, ensure the local connections are excluded from the proxy. Check **System Preferences, Proxies** tab – in the Bypass proxy settings for these Hosts and Domains, to ensure the local network devices are excluded from proxy redirection.

For example: If you open Safari to the printer IP and get an error message similar to Error – the request item could not be loaded by the proxy, you are probably accessing the proxy server for a local address. This is incorrect.

- d. Open the Terminal tool located at **Applications --> Utilities** at the root of the Mac OS X boot disk, and select New Window. Once you have a prompt, try network connectivity using the Ping command.

For example: **ping 13.62.70.112** will check for echo replies from the printer with that IP address.

- e. In the Terminal tool, try using Traceroute to determine if you are on the same subnet as your printer.

For example: **traceroute 13.62.70.112** should produce exactly one hop before completing the trace. Correct as needed, and retry your print job.

- f. If you still cannot connect to the printer via network, try another computer.
4. In Mac OS X, open Printer Setup Utility, located at **Applications => Utilities** at the root of the Mac OS X boot disk. Check to make sure the printer status does not indicate Stopped. If it does, check your network and insure the host system is on the same subnet as the printer. Correct if needed. Delete all jobs in the queue for the printer by double-clicking the printer name, selecting each job, and clicking **Delete**. Restart the print queue by clicking **Start Jobs**. Try your print job again.
 5. In the Printer Setup Utility, select your printer. In the **Printers** menu, select **Show Info**. From the pull-down menu in Printer Info, make sure the configuration shown for the printer is correct. If the configuration is wrong, click the configuration in the pull-down menu, and re-install. Check the Installable Options and make sure they match the printer's configuration. If any changes are made, retry your print job.
 6. If there is still no output, try printing from a simple application. Open TextEdit located at the Applications folder, select **New File**, and create a small test document. Select **Print** from the **File** menu.
 7. If an error message displays or there is no output, try turning on the PostScript error status from CentreWare IS or the printer's Control Panel. PostScript will now output an error page if an error occurred during the print job, assuming the printer received it.

8. Try printing again using the TextEdit tool located at the Applications folder. Once you have opened a document or created a new document, select **Print** from the **File** menu. Click on the **Printer** pull-down menu, and then select **Edit Printer List**. Click the **add** button, or pick **Add Printer** from the **Printers** menu (The add button is configurable, so it may not be there). Select **IP Printing** from the pull-down menu. Put the IP address your printer in the Printer's Address text area. Click on the **Printer Configuration** pull-down menu, and then select **XEROX**. A scrolling list should display. Pick the correct Xerox Phaser 6300 or 6350 configuration. You can check the exact configuration on the printer's Startup page in the upper right corner. The newly added printer displays in bold on the printer list, indicating it is the default printer. When you are done adding the new printer, close the Printer List dialog. Now select your printer from the **Printer** pull-down menu, and then click **Print** in the dialog box.
9. If you can print from the TextEdit tool, but cannot print from your application, the problem is likely in your application. Check for upgrade availability or contact the application vendor for further diagnosis.

Windows Printing Problems

Image never prints

1. Try printing a test page from the printer driver's Properties dialog box.
2. Try printing from another application.
3. Try printing to another network/PostScript printer.
4. Try printing from another computer.
5. If the error returns, turn On the PostScript error handler through the Control Panel PostScript Error Info in the Support menu, or CentreWare IS and print the document again. Take note of the information on the error page that just printed.

Network Problems

The Phaser 6300/6350 printers include diagnostic tools to help resolve networking problems that prevent printing. Located in the Troubleshooting menu is the Network Problems menu. The Network Problems menu lists the Network Diagnostics test and the Network Log Pages. Use these tools to verify network connectivity.

Initial Actions:

- Check that the driver software is properly installed on the host.
- Make sure the network cable is connected at both ends and is serviceable.
- Print a Configuration page to verify the correct IP address, network mask, and gateway are entered into the printer's NVRAM.
- Reboot the printer to clear the network logs.
- If the problem persists, follow the procedure below.

Network Diagnostics

Selecting Network Diagnostics runs a test on the TCP/IP connection (Ethernet Port) and displays the results. If no errors are detected, the message Network diagnostics completed, No problem detected displays, along with options for Help or printing either the Connection Setup or Configuration page. The Connection Setup and Configuration pages list current network parameters stored in the printer's NVRAM. If Network Diagnostics detects an error, the error message displays with menu options to assist in correcting the error. Pressing **Help (?)** provides help text listing steps to help diagnose and clear the error.

In situations where Network Diagnostics completes without an error, but printing continues to fail, test the printer's Ethernet Port directly using a cross-over cable and a second, known good, Ethernet Port. A successful test using this procedure eliminates the printer's networking hardware as the root cause.

Note

The Ethernet Port verification procedures were developed for Windows XP or Mac OS X. If a different operating system is in use, adapt the steps as necessary.

Windows Ethernet Port Verification

1. Connect a crossover cable between the printer and computer's Ethernet Ports.
2. Verify that the printer is Ready To Print.
3. Click **Start**, and then **Run** at the computer to access the **Run** dialog.
4. Type in **cmd** and click **OK** on the **Run** dialog to launch the MS-DOS command window.
5. Type in **ipconfig** at the MS_DOS command prompt and press **Enter** to display the computer's IP address, subnet mask, and gateway.
6. Print the Configuration page to verify that TCP/IP is enabled and obtain the current TCP/IP values stored in the printer's NVRAM.

Note

Configure the printer's TCP/IP network parameters to enable direct communication with the computer.

7. Disable DHCP/BOOTP and AutoIP on the printer.
8. Select an IP address for the printer that matches the computer, except for the last field, which must be unique.
9. Edit the printer's gateway and subnet mask to match the computer.
10. Type **ping** followed by a space and the printer's IP address at the MS_DOS command prompt, and then press **Enter**. If the number of packets sent and received match, the Ethernet Port is functional. If the request times out and fails to reply, either the cable or the port is defective.

Mac OS X Ethernet Port Verification

1. Turn the printer on and wait until it is Ready to Print.
2. To check the computer's TCP/IP settings, use the Apple menu to select System Preferences.
3. Select **Network**.
4. Select **Show Built-in Ethernet**.
5. Click the **TCP/IP** tab and record the computer's IP address, subnet mask, and gateway.
6. Print the Configuration page and verify that TCP/IP is enabled on the printer.
7. Select an IP address for the printer that matches the computer, except for the last field, which must be unique.
8. Edit the printer's gateway and subnet mask to exactly match the computer's.
9. Connect a crossover cable between the Ethernet ports on the printer and the Mac.
10. Test the application using Network Utility by double-clicking the hard drive icon.
11. Select **Applications --> Utilities --> Network Utility**.
12. Click the **PING** tab.

13. Enter the printer's IP address.
14. Configure the utility to PING the printer four times. The test will end after four attempts.
15. Click the **PING** button to complete the test.
16. If the number of packets sent and received match, the test was successful and the Ethernet port is functioning. If the request times out and fails, the cable or the port are malfunctioning.

Network Logging

Four logs are stored in the printer that detail network functions. The logs contain TCP/IP and AppleTalk initialization and runtime events. The logs can also be accessed remotely via CentreWare IS. The logs list events chronologically. The log is limited in length; when the log is full the printer stops recording data to the log. The logs are cleared each time the printer's power is cycled.

To print the network logs:

1. On the Control Panel, select **Troubleshooting**, and then press the **OK** button.
2. Select the **Network Problems** menu, and then press the **OK** button.
3. Select the **Network Log Pages** menu, and then press the **OK** button..
4. Select the desired log, and then press the **OK** button.

USB Port Testing

Initial Actions:

- Check that the driver software is properly installed on the host.
- Make sure the USB cable is connected at both ends and is serviceable.
- Print a Configuration page and verify that USB 2.0 is enabled in the printer's NVRAM.
- Reboot the printer.
- If the problem persists, follow the procedure below.

Note

The testing procedure was developed for Windows XP. If a different operating system is in use, adapt the steps as necessary.

In situations where USB communications fail, test the printer's USB Port directly using a USB cable and a second, known good, USB Port. A successful test using this procedure eliminates the printer's USB Port as the root cause.

1. Verify that the printer is Ready To Print.
2. Insert the Phaser 6300/6350 Installer and Utilities CD-ROM into the computer.
3. If the installer autoruns, exit the installer window.
4. Connect a USB cable between the printer and computer's USB Ports. The computer automatically detects the new hardware and creates a driver.

Note

If the driver is not installed on the computer, locate the driver files on the CD-ROM. Once the files are located, the computer installs the driver and automatically configures it to match the printer's feature set.

5. Open the **Printers and Faxes** window on the computer by clicking **Start**, **Settings**, and then **Printers and Faxes**.
6. Locate the correct entry for the printer being tested and display its properties from the **File** menu pull-down.
7. Open the **General** tab and click the **Print Test Page** button to generate the test print. If the test page prints, the USB port is functioning normally.

Print-Quality Troubleshooting

In this chapter...

- Print-Quality Problems Overview
- Control Panel Test Prints
- Service Test Prints
- Print Engine Test Print
- Print-Quality Troubleshooting

Section 5

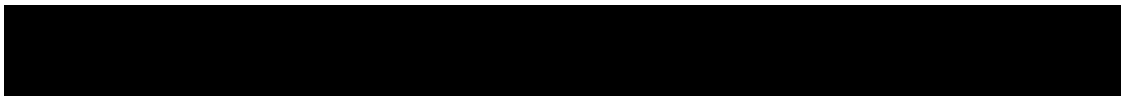

Print-Quality Problems Overview

Print-quality defects can be attributed to printer components, consumables, media, internal software, external software applications, and environmental conditions. To successfully troubleshoot print-quality problems, eliminate as many variables as possible. The first step is to generate prints using printable pages embedded in the printer on laser paper from the supported media list. Use paper from a fresh ream that is acclimated to room temperature and humidity.

See "Media and Tray Specifications" on page 1-17 or the Paper Tips page for media that has been tested and approved for use in Phaser 6300/6350 printers. If the print-quality defect is still present when printing on approved media from an unopened ream, then investigate software applications and environmental conditions.

Print the Status or Configuration page to determine the temperature and humidity under which the printer is operating. Compare this to the "Environmental Specifications" on page 1-16. Temperature and humidity extremes can adversely affect the xerographic and fusing characteristics of the printer.

Phaser 6300/6350 printers use separate Developer Assemblies to develop a latent image for each color on the Imaging Unit where the colors are combined to form the final image. In most cases, print-quality defects are the result of one particular component in the print engine. See the Repeating Defects chart under "Defects Associated with Specific Printer Components" on page 5-3 or print the Repeating Defects page from the Control Panel. When a single component of the Imaging Unit is causing a print-quality defect, replace the Imaging Unit.

When analyzing a print-quality defect, first determine if the defect occurs in all colors or only one color and if it is repeating or random. Continuous defects in the process direction, such as voids and lines, are the most difficult to diagnose. Inspect the visible surfaces of all rollers for obvious defects. If no defects are observed, replace the Imaging Unit, Developer Assembly, Transfer Roller, and Fuser one at a time until the defect is eliminated.

Defects Associated with Specific Printer Components

Some print-quality problems can be associated with specific assemblies, the most common problems and the associated assemblies are listed below. Also, refer to the printer's Troubleshooting Print Quality Problems pages or a specific print-quality troubleshooting procedure for more information.

Developer Assembly

- Blank Prints
- Light Prints
- Uneven Density
- Voids (White spots)
- Streaks (Dark/ light)
- Repeating Defects

Imaging Unit

- Streaks
- Ghosting
- Fine Lines
- Banding in Process Direction
- Uneven Density
- Voids
- Repeating Defects

Note

See "Cleaning the Imaging Unit" on page 7-3 for instructions on how to clean the Imaging Unit rollers.

Transfer Roller

- Toner on the back side of the printed page (simplex mode)
- Light Prints
- Repeating Defects

Fuser

- Hot or Cold Offsetting
- Repeating Defects

Repeating Defects

| Maintenance Item | Component | Distance between Defects |
|----------------------|------------------------------|--------------------------|
| Developer Assemblies | Magnetic (Mag) Roller [YMCK] | 34 mm (1.34 in.) |
| Imaging Unit | Drum Charge (RTC) Rollers | 31 mm (1.22 in.) |
| | OPC Drum Rollers | 74 mm (2.91 in.) |
| | IDT Rollers | 132 mm (5.20 in.) |
| Transfer Roller | Transfer Roller | 64 mm (2.52 in.) |
| Fuser | Heat Roller | 83 mm (3.26 in.) |
| | Belt | 94 mm (3.70 in.) |

Test Prints

A variety of test prints are available to aid in determining the quality of output from the printer and to assist in troubleshooting problems. This section shows how to select and analyze test prints.

On the Control Panel, select **Troubleshooting**, select **Service Tools**, and then **Service Test Pages**.

Test Print 1: CMYK Sample Page

This page consists of four 25% tint primary color bands.

Analyzing the Test Print

- Repeating defects
- Missing Color(s)
- Streaks
- Voids
- Banding

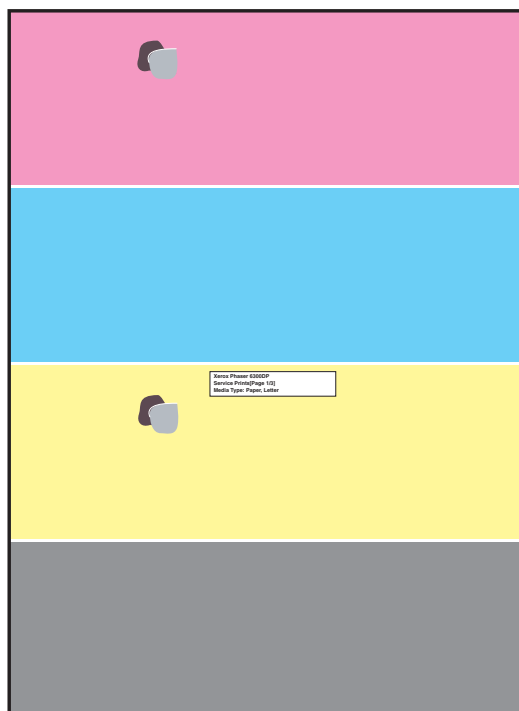

s6300-101

Test Print 2: RGB Test Print

This page consists of 80% solid fill in RGBK Bands.

Analyzing the Test Print

- Wrinkling
- Creases
- Roller marks
- Scratches
- Cold Offset

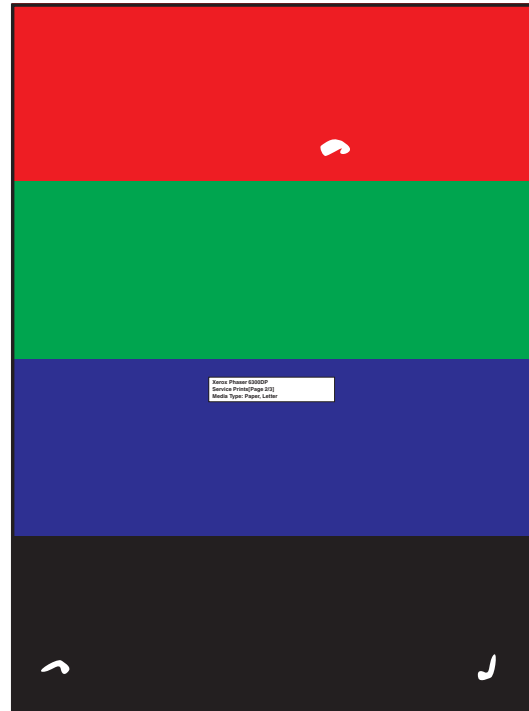

s6300-102

Analyzing the Test Patterns

1. Color Registration (Horizontal): The colored lines should match up as shown below. Perform the color registration procedure. See "Vertical and Horizontal Color Registration" on page 6-3.

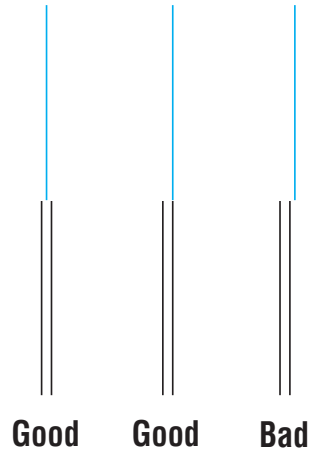

s6300-104

2. Color Registration (Vertical): The colored lines should match up as shown below. Vertical printing issues are corrected automatically when the Color Registration page is printed.

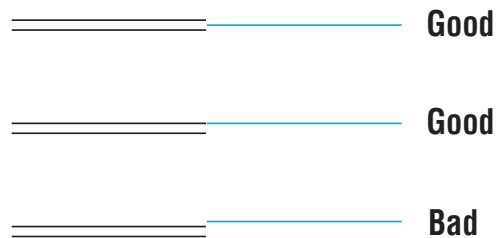

s6300-105

3. Uniform RGB: The secondary color squares should be uniformly colored with no mottling.
4. Density: The color bars should have even density from top to bottom.
5. Margins: Should be 8 mm from the edge of the paper to the line.
6. Image Size: the image height should be 261 mm between the top and bottom lines. The image width should be 192 mm between the left and right lines.

600 x 600 Test Print

This test print is used to verify margins and color registration. The colors should be aligned vertically and horizontally.

Correctly Aligned Registration Example

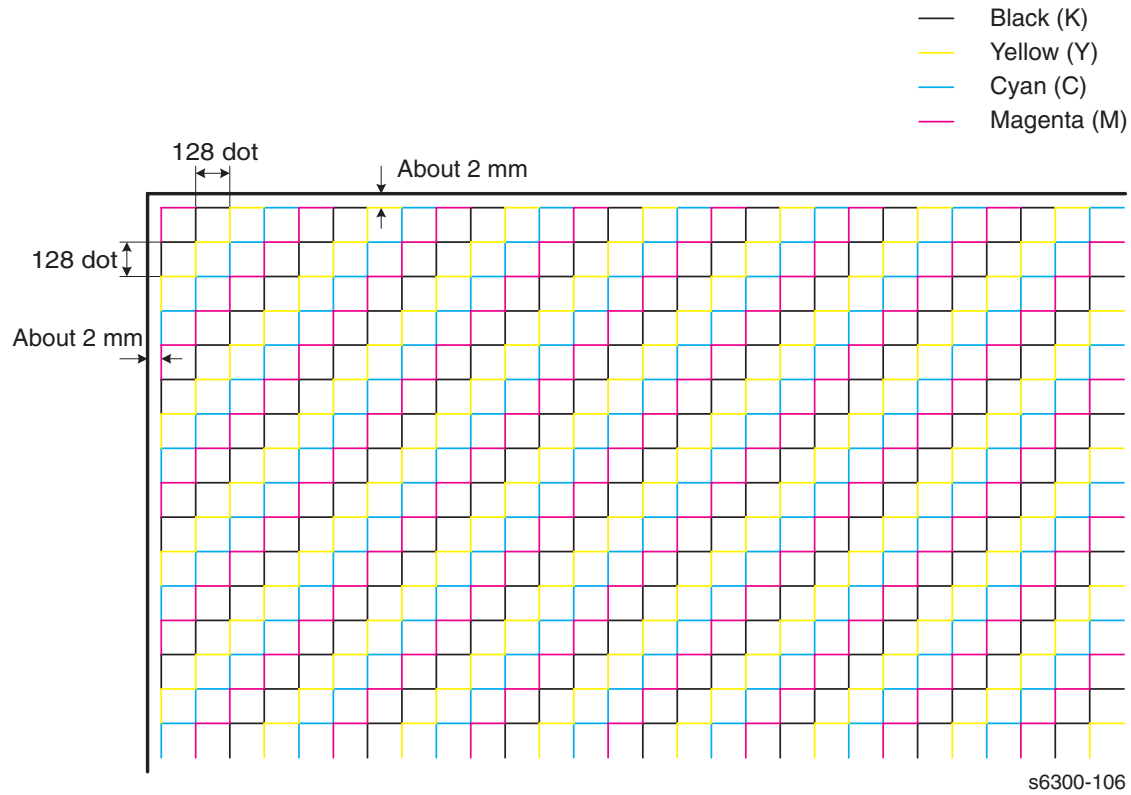

Engine Test Print

Isolate printer hardware problems to either the Engine Control or Image Processor Board by running the Engine Test print. If the print is successfully printed, focus on the Image Processor Board or its components (RAM, Hard Drive, Configuration Card, etc.). If the print fails, refer to Section 4 for print engine troubleshooting help.

1. Press the **Test Print** button located on the Rear Panel.
2. The printer prints the 600 x 600 test print unless an error status from the Engine Control Board is present.

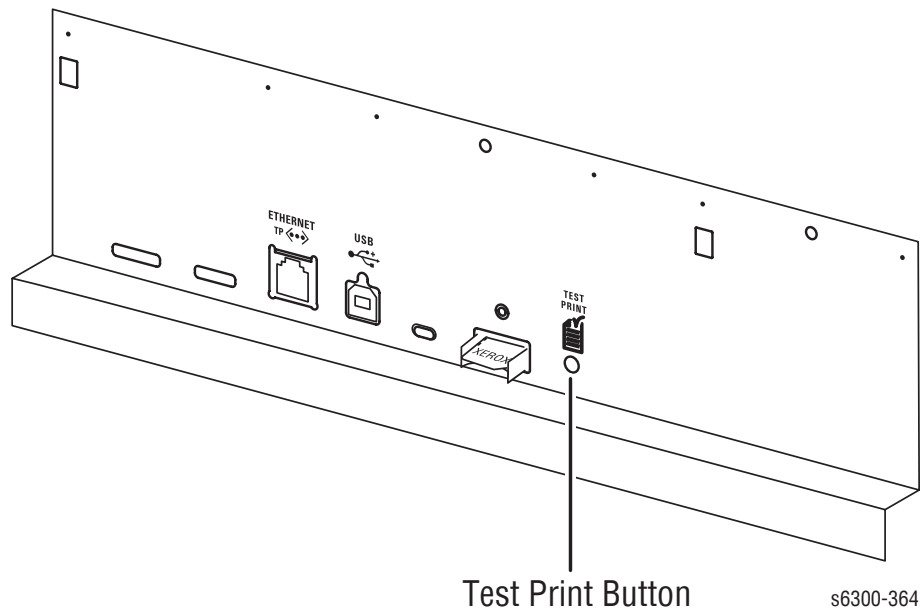

Print-Quality Troubleshooting

Light Prints

The overall image density is too light.

Initial Actions

- Verify the media used is supported by this printer.
- Verify the media settings are correct at the Control Panel.
- Run the color calibration routine prior to using this troubleshooting procedure.

Troubleshooting Reference Table

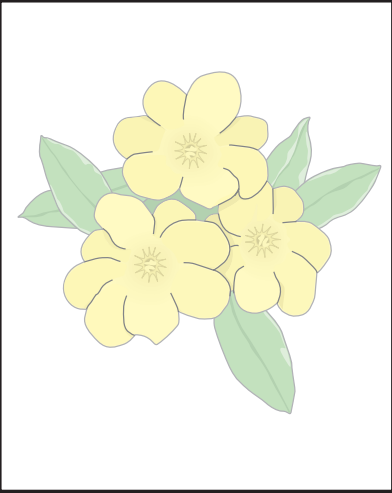
| Applicable Parts | Example Print |
|--|--|
| <ul style="list-style-type: none">■ Imaging Unit, PL6.1.1■ Developer Assemblies, PL7.1.17~20■ Laser Unit, PL6.1.2■ Transfer Roller, PL5.1.4■ HVPS, PL9.1.21■ Engine Control Board, PL9.1.16 |  <p>s6300-108</p> |

Troubleshooting Procedure Table

| Step | Actions and Questions | Yes | No |
|------|---|--|---------------|
| 1 | Check the Imaging Unit and Transfer Roller for correct installation, damage, contamination, and life remaining. | Replace or reinstall the affected component. | Go to Step 2. |
| 2 | Replace the Imaging Unit (page 8-5). Does the image quality improve? | Complete | Go to Step 3. |
| 3 | Replace the Transfer Roller (page 8-5). Does the image quality improve? | Complete | Go to Step 4. |

Troubleshooting Procedure Table (Continued)

| Step | Actions and Questions | Yes | No |
|------|--|---------------|-----------------------------|
| 4 | Replace the Laser Unit (page 8-76). Does the image quality improve? | Complete | Go to Step 5. |
| 5 | Replace the Engine Control Board (page 8-104). Does the image quality improve? | Complete | Go to Step 6. |
| 6 | Replace the HVPS (page 8-109). Does the image quality improve? | Complete | Go to Step 7. |
| 7 | Check the Developer Assembly gear train, PL8.1.1, if the symptom is light density or missing color. Symptoms can be all colors, only one color, and only CMY color. If CMY color only is bad (black is good), this is most likely the root cause. Does the image quality improve? | Complete | Go to Step 8. |
| 8 | Replace the Developer Assemblies for the affected colors. Does the image quality improve? | Complete | Go to Step 9. |
| 9 | Replace the Toner Dispense Assembly (Toner Cartridge Holder) for the affected colors (page 8-85). Does the image quality improve? | Complete | Go to Step 10. |
| 10 | Check the Wire Assembly BTR continuity. J138 <=> J139. | Go to Step 5. | Replace the defective wire. |

Light Print in Only One Color

Only one color; yellow, magenta, cyan, or black, is too light on the printed image. The test print is 25% coverage.

Initial Actions

- Verify that color calibration has been performed prior to using this troubleshooting procedure.
- Check that the Toner Cartridge pull strip is completely removed from the affected color.

Troubleshooting Reference Table

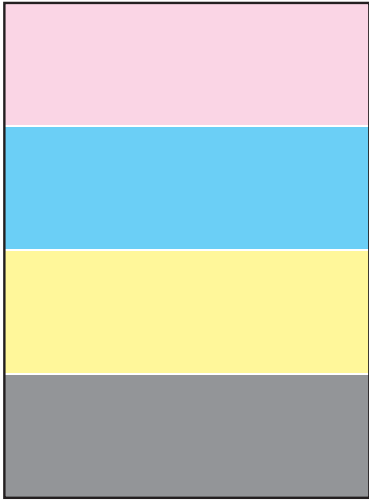
| Applicable Parts | Example Print |
|--|--|
| <ul style="list-style-type: none">■ Imaging Unit, PL6.1.1■ Developer Assemblies, PL7.1.17~20■ Laser Unit, PL6.1.2■ Engine Control Board, PL9.1.16■ Toner Supply■ Housing Assembly Bias, PL6.1.7 |  <p>s6300-109</p> |

Troubleshooting Procedure Table

| Step | Actions and Questions | Yes | No |
|------|---|--|--|
| 1 | Is the affected color(s) toner supply empty? (Check the top of the auger tube for the affected color.) | Replace the affected Toner Cartridge (page 8-6). | Go to Step 2. |
| 2 | Check the Imaging Unit for correct installation, damage or contamination. Verify the shipping seals are completely removed. | Replace the Imaging Unit (page 8-5). | Go to Step 3. |
| 3 | Inspect the Developer Bias spring of the affected color. Compare it to the other colors. Check for contamination or damage. | Go to Step 4. | Replace the Housing Assembly Bias (page 8-77). |

Troubleshooting Procedure Table (Continued)

| Step | Actions and Questions | Yes | No |
|------|---|--------------------------------|--|
| 4 | Check for any obstructions or debris in the laser beam path between the Laser Unit and the Imaging Unit. | Remove obstructions or debris. | Go to Step 5. |
| 5 | <p>WARNING: Turn printer power Off and disconnect the AC power cord before proceeding with the following checks.</p> <p>Check the affected colors connection between the HVPS and Housing Assembly Bias for continuity and damage.</p> <p>JP101/102 <=>DA Y contact JP103/104 <=>DB M contact JP105/106 <=>DC C contact JP107/108 <=>DD K contact</p> | Go to Step 6. | Replace the Housing Assembly Bias (page 8-77). |
| 6 | Check the Developer Assembly gear train, PL8.1.1. Symptoms can be all colors, only one color, and only CMY color. IF CMY color only is bad (black is good), this is most likely the root cause. Does the image quality improve? | Complete | Go to Step 7. |
| 7 | Replace the affected color's Developer Assembly. Does the image quality improve? | Complete | Go to Step 8. |
| 8 | Replace the Laser Unit (page 8-76). Does the image quality improve? | Complete | Replace the Engine Control Board (page 8-104). |

Blank Prints

Initial Actions

- Run the Engine Test print to help isolate the problem between the Image Processor Board and the Engine Control Board.

Troubleshooting Reference Table

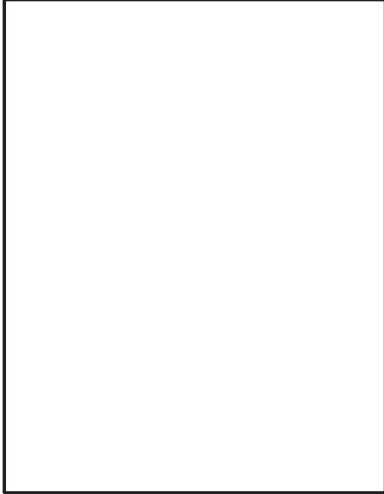
| Applicable Parts | Example Print |
|--|---|
| <ul style="list-style-type: none">■ Imaging Unit, PL6.1.1■ Developer Frame Assembly, PL7.1.1■ Developer Drive Assembly, PL8.1.1■ Laser Unit, PL6.1.2■ Engine Control Board, PL9.1.16 |  <p>s6300-110</p> |

Troubleshooting Procedure Table

| Step | Actions and Questions | Yes | No |
|------|--|-------------------------|---------------|
| 1 | Check for any obstructions or debris in the laser beam path between the Laser Unit and the Imaging Unit. | Remove any obstruction. | Go to Step 2. |
| 2 | Replace the Imaging Unit (page 8-5). Did the image quality improve? | Complete | Go to Step 3. |
| 3 | Replace the Transfer Roller (page 8-5). Did the imaging quality improve? | Complete | Go to Step 4. |
| 4 | Replace the Laser Unit (page 8-76). Does the image quality improve? | Complete | Go to Step 5. |
| 5 | Replace the HVPS (page 8-109). Does the image quality improve? | Complete | Go to Step 7. |

Troubleshooting Procedure Table (Continued)

| Step | Actions and Questions | Yes | No |
|------|--|----------|--|
| 6 | Check the Developer Drive Assembly, PL8.1.1, for damage or wear. Symptoms can be all colors, only one color, and only CMY color. If CMY color only is bad (black is good), this is most likely the root cause. | Complete | Go to Step 8. |
| 7 | Replace the Developer Frame Assembly (page 8-78). Does the image quality improve? | Complete | Replace the Engine Control Board (page 8-104). |

Black Prints with White Margin Border

The entire image area, except the margins, are black.

Troubleshooting Reference Table

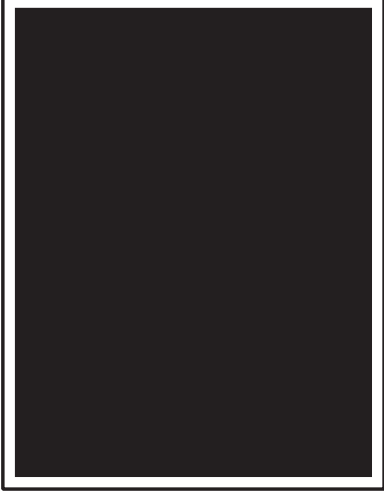
| Applicable Parts | Example Print |
|---|--|
| <ul style="list-style-type: none"> ■ Imaging Unit, PL6.1.1 ■ Developer Frame Assembly, PL7.1.1 ■ Laser Unit, PL6.1.2 ■ HVPS, PL9.1.21 ■ Engine Control Board, PL9.1.16 |  <p style="text-align: right; margin-top: 10px;">s6300-111</p> |

Troubleshooting Procedure Table

| Step | Actions and Questions | Yes | No |
|------|--|--|--|
| 1 | Print an Engine Test Print. See (page 5-9). Does the output match the example on page 5-8? | Replace the Image Processor Board (page 8-98). | Go to Step 2. |
| 2 | Block the laser path with a sheet of paper. Does the image change? | Replace the Engine Control Board (page 8-104). | Go to Step 3. |
| 3 | Replace the Imaging Unit ("Imaging Unit Removal" on page 8-5). Does the image quality improve if the Imaging Unit is replaced? | Complete | Go to Step 4. |
| 4 | Replace the Laser Unit (page 8-76). Does the image quality improve? | Complete | Go to Step 5. |
| 5 | Replace the HVPS. Did the image quality improve? | Complete | Go to Step 6. |
| 6 | Replace the Developer Frame Assembly (page 8-78). Does the image quality improve? | Complete | Replace the Engine Control Board (page 8-104). |

Solid Dark or Dirty Prints, No Border

This print-quality symptom is a composite image of all colors with no margin. This is caused by a charge voltage or cleaning system failure.

Troubleshooting Reference Table

| Applicable Parts | Example Print |
|--|---|
| <ul style="list-style-type: none"> ■ Imaging Unit, PL6.1.1 ■ Developer Frame Assembly, PL7.1.1 ■ HVPS, PL9.1.21 ■ Engine Control Board, PL9.1.16 ■ Housing Assembly Bias, PL6.1.7 |  <p style="text-align: right; margin-top: 5px;">s6300-112</p> |

Troubleshooting Procedure Table

| Step | Actions and Questions | Yes | No |
|------|---|----------|--|
| 1 | Replace the Imaging Unit (page 8-5). Is the problem resolved after replacing the Imaging Unit? | Complete | Go to Step 2. |
| 2 | Replace the Transfer Roller (page 8-5). Did the imaging quality improve? | Complete | Go to Step 3. |
| 3 | <p>WARNING: Turn printer power Off and disconnect the AC power cord before proceeding with the following checks.</p> Inspect the Imaging Unit charge voltage contacts and the Housing Assembly Bias for any damage or defects. | Complete | Go to Step 4. |
| 4 | Replace the HVPS (page 8-109). Is the problem resolved after replacing the HVPS? <p>NOTE: After replacing any component in Step 2 or 3, run the Clean the Imaging Unit from the Maintenance section of Service Diagnostics. See "Service Diagnostics" on page 4-6.</p> | Complete | Replace the Engine Control Board (page 8-104). |

Horizontal Bands, Voids Or Streaks in Any or All Colors

There are areas of the image that are extremely light or missing entirely. These missing areas form bands parallel to the leading edge.

Initial Actions

- Confirm that the paper is supported. Poor quality papers can contribute to this type of problem.
- Ask the customer about their typical printing habits. Continuously printing long print jobs with heavy coverage can temporarily cause banding.

Troubleshooting Reference Table

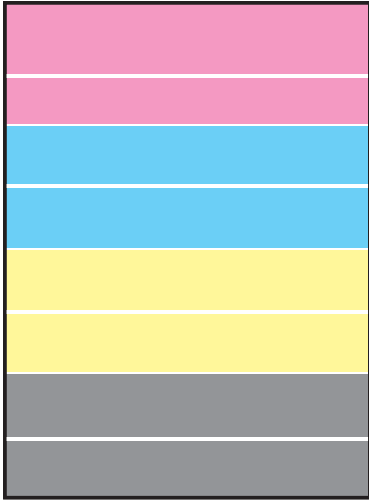
| Applicable Parts | Example Print |
|--|---|
| <ul style="list-style-type: none"> ■ Imaging Unit, PL6.1.1 ■ Fuser, PL5.1.1 ■ Transfer Roller, PL5.1.4 ■ Laser Unit, PL6.1.2 ■ HVPS, PL9.1.21 ■ Image Processor Board, PL9.1.3 ■ Engine Control Board, PL9.1.16 |  <p style="text-align: right; font-size: small;">s6300-113</p> |

Troubleshooting Procedure Table

| Step | Actions and Questions | Yes | No |
|------|--|--|---------------|
| 1 | Is the paper wrinkled or dimpled? Is the problem resolved by loading fresh, dry paper? | Complete | Go to Step 2. |
| 2 | Print a Repeating Defects page. Do the defects correspond to a maintenance Item? See "Repeating Defects" on page 5-4 | Replace the maintenance items indicated. | Go to Step 3. |
| 3 | Replace the Imaging Unit (page 8-5). Does the image quality improve? | Complete | Go to Step 4. |
| 4 | Replace the Transfer Roller (page 8-5). Does the image quality improve? | Complete | Go to Step 5. |

Troubleshooting Procedure Table (Continued)

| Step | Actions and Questions | Yes | No |
|-------------|--|------------|--|
| 5 | Replace the Fuser (page 8-5). Does the image quality improve? | Complete | Go to Step 6. |
| 6 | Replace the HVPS (page 8-109). Does the image quality improve if the HVPS is replaced? | Complete | Go to Step 7. |
| 7 | Replace the Laser Unit (page 8-76). Does the image quality improve if the Laser Unit is replaced? | Complete | Replace the Engine Control Board (page 8-104). |

Vertical Bands, Voids or Streaks in Any or All Colors

There are areas of the image that are extremely light or missing entirely. These missing areas form bands that run along the paper from the leading edge to the trailing edge, in the direction of paper travel.

Initial Actions

- Using a flashlight, carefully examine the area around the Laser window and the openings between the Developer Assemblies. Small obstructions, such as hair or fibers, can create streaks.

Troubleshooting Reference Table

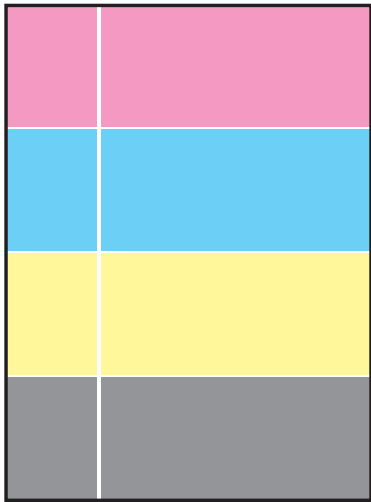
| Applicable Parts | Example Print |
|--|--|
| <ul style="list-style-type: none"> ■ Imaging Unit, PL6.1.1 ■ Fuser, PL5.1.1 ■ Transfer Roller, PL5.1.4 ■ Developer Frame Assembly, PL7.1.1 ■ Engine Control Board, PL9.1.16 |  <p>s6300-114</p> |

Troubleshooting Procedure Table

| Step | Actions and Questions | Yes | No |
|------|--|-----------------------------------|---------------|
| 1 | Check for obstructions between the Laser Unit and the Imaging Unit. Remove the Imaging Unit and inspect each OPC Drum and corresponding area. Remove any debris such as hair, foam or paper. | Remove the obstruction or debris. | Go to Step 2. |
| 2 | Replace the Imaging Unit (page 8-5). Does the image quality improve? | Complete | Go to Step 3. |
| 3 | Replace the Transfer Roller (page 8-5). Does the imaging quality improve? | Complete | Go to Step 4. |
| 4 | Replace the Fuser (page 8-5). Does the image quality improve? | Complete | Go to Step 5. |

Troubleshooting Procedure Table (Continued)

| Step | Actions and Questions | Yes | No |
|------|---|----------|--|
| 5 | <p>CAUTION: Do not clean the Developer Assembly rollers with a cloth. Carefully remove debris from the rollers using tweezers or similar tool.</p> <p>Remove the Developer Frame Assembly (page 8-78). Using a lint free cloth, carefully clean the Laser window and between each Developer Assembly.</p> <p>Does the image quality improve?</p> | Complete | Go to Step 6. |
| 6 | <p>Replace the Developer Frame Assembly (page 8-78).</p> <p>Does the image quality improve?</p> | Complete | Go to Step 7. |
| 7 | <p>Replace the Laser Unit (page 8-76).</p> <p>Does the image quality improve?</p> | Complete | Replace the Engine Control Board (page 8-104). |

Repeating and/or Random Spots

Spots of toner are randomly scattered across the page or at a fixed repeating interval.

Initial Actions

- Verify the Imaging Unit and Transfer Roller are not at or near end of life. Waste toner especially from the Transfer Roller can cause random spots to appear on the page.

Note

Depending on the type of paper and environmental conditions, some light amount of random background spotting (backgrounding) is normal. The whiter and glossier the paper, the more noticeable it will be.

Troubleshooting Reference Table

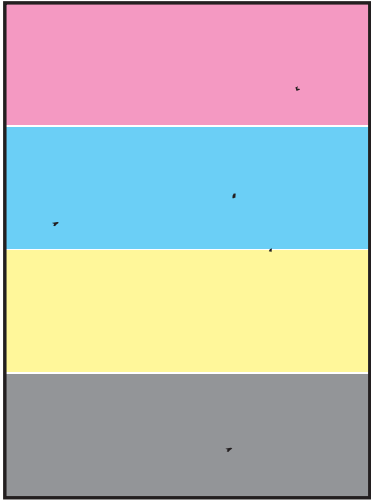
| Applicable Parts | Example Print |
|---|--|
| <ul style="list-style-type: none">■ Imaging Unit, PL6.1.1■ Fuser, PL5.1.1■ Transfer Roller, PL5.1.4 |  <p>s6300-115</p> |

Troubleshooting Procedure Table

| Step | Actions and Questions | Yes | No |
|------|--|---|---------------|
| 1 | Print the Repeating Defects page from the Troubleshooting ->Print Quality Problems menu. Do the defects correspond to a maintenance Item? See "Repeating Defects" on page 5-4. | Replace the maintenance item indicated. | Go to Step 2. |
| 2 | Clean the Imaging Unit rollers (page 7-3). Does the image quality improve? | Complete | Go to Step 3. |

Troubleshooting Procedure Table (Continued)

| Step | Actions and Questions | Yes | No |
|------|--|---------------|--|
| 3 | Check each Developer Assembly roller for debris or damage, Does the image quality improve? | Complete | Go to Step 4. |
| 4 | Replace the Imaging Unit (page 8-5). Does the image quality improve? | Complete | Go to Step 5. |
| 5 | Replace the Transfer Roller (page 8-5). Does the image quality improve? | Complete | Go to Step 6. |
| 6 | Replace the Fuser (page 8-5). Does the image quality improve? | Complete | Go to Step 7. |
| 7 | Check that the springs on the Housing Assembly Bias PL6.1.7 are not damaged and are correctly aligned to ensure contact with the Imaging Unit. Are the springs in contact? | Go to Step 8. | Repair or replace the Housing Assembly Bias. |
| 8 | Replace the HVPS (page 8-109). Does the image quality improve? | Complete | Replace the Engine Control Board (page 8-104). |

Background Contamination

There is toner contamination on all or most of the page. The contamination appears as a very light gray dusting. The printer displays no error code.

Note

Depending on the type of paper and environmental conditions, some light amount of random background spotting (backgrounding) is normal. The whiter and glossier the paper, the more noticeable it will be.

Initial Actions:

- Ensure the TekColor correction is not set to **None** in the printer's dialog box.
- Ask the customer about their typical printing habits. A high daily duty cycle can temporarily fatigue the OPC drums within the Imaging Unit and contribute to unwanted background toner.

Troubleshooting Reference Table

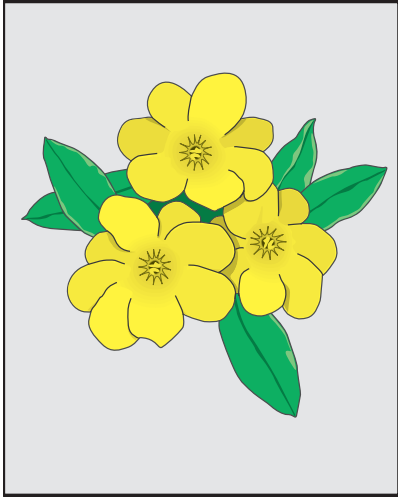
| Applicable Parts | Example Print |
|---|--|
| <ul style="list-style-type: none">■ Imaging Unit, PL6.1.1■ Fuser, PL5.1.1■ Transfer Roller, PL5.1.4■ Developer Frame Assembly, PL7.1.1■ HVPS, PL9.1.21■ Engine Control Board, PL9.1.16 |  <p>s6300-116</p> |

Troubleshooting Procedure Table

| Step | Actions and Questions | Yes | No |
|------|---|--|---------------|
| 1 | Check the Imaging Unit, Fuser, and Transfer Roller for correct installation, damage or contamination. | Replace or reinstall the affected component. | Go to Step 2. |

Troubleshooting Procedure Table (Continued)

| Step | Actions and Questions | Yes | No |
|------|--|---|--|
| 2 | Inspect the surface of the Transfer Roller for waste toner. The roller should appear black and shiny. Is the roller contaminated with waste toner? | Replace the Transfer Roller (page 8-5). | Go to Step 4. |
| 3 | Replace the Transfer Roller (page 8-5). Does the image quality improve? | Complete | Go to Step 4. |
| 4 | Replace the Imaging Unit (page 8-5). Does the image quality improve? | Complete | Go to Step 5. |
| 5 | Replace the Developer Frame Assembly (page 8-78). Does the image quality improve? | Complete | Go to Step 6. |
| 6 | Replace the Fuser (page 8-5). Does image quality improve? | Complete | Go to Step 7. |
| 7 | Replace the Laser Unit (page 8-76). Does the image quality improve? | Complete | Go to Step 8. |
| 8 | Replace the High Voltage Power Supply (page 8-109). Does the image quality improve? | Complete | Replace the Engine Control Board (page 8-104). |

Residual Image, Ghosting or Hot Offset

There are faint, ghostly images appearing on the page. The images may be either from a previous page or from the page currently printed. The printer displays no error code. This type of artifact can be related to the percent coverage called out in the file being printed.

Hot Offset: A light image of the print is repeated and offset 82 mm. See "Repeating Defects" on page 5-4.

Initial Actions:

- Verify the correct media type is set at the Control Panel
- Make sure the customer is using TekColor correction (limiting color to max 240%). Other graphic applications can exceed 240%.

Note

For Phaser 6350 configurations, 36 ppm color printing limits color coverage to a maximum of 200%.

- Try printing with fresh media from a recently opened ream.

Troubleshooting Reference Table

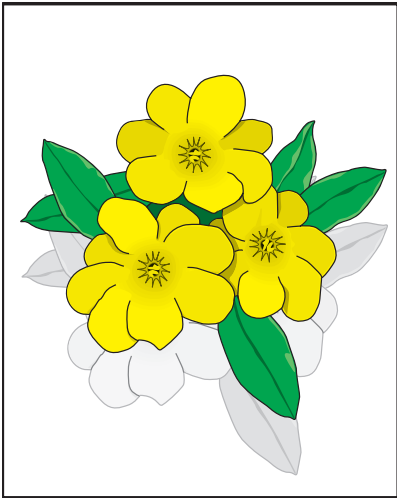
| Applicable Parts | Example Print |
|---|---|
| <ul style="list-style-type: none">■ Imaging Unit, PL6.1.1■ Fuser, PL5.1.1■ Transfer Roller, PL5.1.4■ LVPS, PL9.1.6■ Temp/Humidity Sensor, PL9.1.20■ Engine Control Board, PL9.1.16 |  <p>s6300-117</p> |

Troubleshooting Procedure Table

| Step | Actions and Questions | Yes | No |
|------|--|------------------------------------|---------------|
| 1 | Was the customer printing numerous copies of the same image? | Avoid long runs of the same image. | Go to Step 2. |

Troubleshooting Procedure Table (Continued)

| Step | Actions and Questions | Yes | No |
|------|--|--|---|
| 2 | Set the paper type to the next heaviest type. Does this resolve the problem? | Complete | Go to Step 3. |
| 3 | Replace the Fuser (page 8-5). Does the image quality improve? | Complete | Go to Step 4. |
| 4 | Replace the Transfer Roller (page 8-5). Does the imaging quality improve? | Complete | Go to Step 5. |
| 5 | Replace the LVPS (page 8-99). Does the image quality improve? | Complete | Go to Step 6. |
| 6 | Print a Status page, do the temperature and humidity values reported seem to agree with the actual conditions? | Replace the Engine Control Board (page 8-104). | Replace the Temperature/Humidity Sensor (page 8-108). |

Incomplete Fusing or Cold Offset

The toner is not completely fused to the paper and easily rubs or flakes off.

Initial Actions:

- Verify the correct media type is set at the printer's Control Panel.

Troubleshooting Reference Table

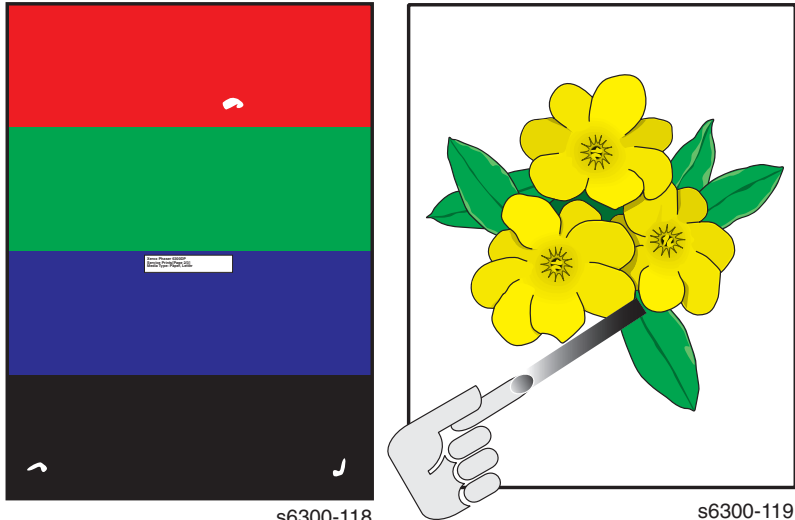
| Applicable Parts | Example Prints |
|--|---|
| <ul style="list-style-type: none"> ■ Fuser, PL5.1.1 |  |

Troubleshooting Procedure Table

| Step | Actions and Questions | Yes | No |
|------|---|-------------------------------|----------------------|
| 1 | <p>Is the problem resolved by running "Remove Print Smears" from the Troubleshooting -> Print Quality Problems menu.</p> <p>Is the problem resolved by changing the paper type setting on the printer?</p> <p>Hot offset: One type lighter.</p> <p>Cold offset / Incomplete fusing: One type heavier.</p> | Complete | Go to Step 2. |
| 2 | <p>Check the paper setting for the tray.</p> <p>Does the loaded paper type/size match the setting displayed on the Control Panel?</p> | Go to Step 3. | Correct the setting. |
| 3 | <p>Replace the Fuser (page 8-5).</p> <p>Does the problem persist?</p> | Replace the LVPS (page 8-99). | Complete. |

Mis-Registration, Color Layers Not Correctly Registered

The four colors of the image are not registered correctly into one image.

Initial Actions:

- If the mis-registration is in the horizontal direction, perform the color registration adjustment, see (page 6-3).
- If the mis-registration is in the vertical direction, clean the CTD (ADC) Sensor, and then print the Color Registration page.

Troubleshooting Reference Table

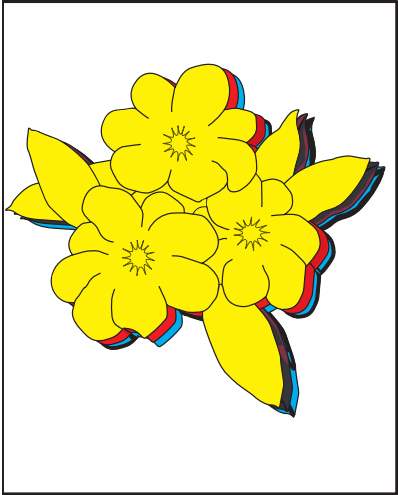
| Applicable Parts | Example Print |
|--|--|
| <ul style="list-style-type: none"> ■ Imaging Unit, PL6.1.1 ■ Laser Unit, PL6.1.2 ■ CTD Sensor, PL5.2.19 ■ Transfer Roller, PL5.1.4 ■ HVPS, PL9.1.21 ■ Image Processor Board, PL9.1.3 ■ Engine Control Board, PL9.1.16 |  <p style="text-align: right; margin-top: 5px;">s6300-120</p> |

Troubleshooting Procedure Table

| Step | Actions and Questions | Yes | No |
|------|--|--|---------------|
| 1 | Reseat the Imaging Unit. Latch Door C, and check that the Transfer Roller is fully seated and clipped in place. Is the problem resolved? | Complete | Go to Step 2. |
| 2 | Clean the CTD (ADC) Sensor. Is the problem resolved? | Complete | Go to Step 3. |
| 3 | Replace the CTD (ADC) Sensor (page 8-71). Is the problem resolved? | Complete | Go to Step 4. |
| 4 | Print the 600 x 600 Service Test Print. Are all the colors aligned both vertically and horizontally? | Replace the Image Processor Board (page 8-98). | Go to Step 5. |

Troubleshooting Procedure Table (Continued)

| Step | Actions and Questions | Yes | No |
|------|---|----------|--|
| 5 | Replace the Laser Unit, (page 8-76). Does the image quality improve? | Complete | Replace the Engine Control Board (page 8-104). |

Dirty Vertical Streaks on the Edges of the Page

Simplex Print: Streaks are on the back side of the page.

Duplex Print: Streaks are on both sides of the page.

Note

The most likely cause of this artifact is high clay content paper. This component in the paper gums up the Transfer Roller cleaning blade. It can also be caused by a full Transfer Roller waste toner reservoir and other problems.

Troubleshooting Reference Table

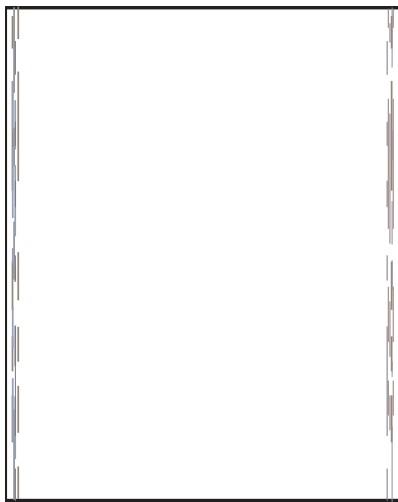
| Applicable Parts | Example Print |
|--|--|
| <ul style="list-style-type: none">■ Imaging Unit, PL6.1.1■ Transfer Roller, PL5.1.4 |  <p>s6300-121</p> |

Troubleshooting Procedure Table

| Step | Actions and Questions | Yes | No |
|------|--|----------|---|
| 1 | Is the problem resolved by using different media? | Complete | Replace the Transfer Roller (page 8-5). |
| 2 | Replace the Transfer Roller (page 8-5). Does the imaging quality improve? | Complete | Replace the Imaging Unit (page 8-5). |

Adjustments and Calibrations

In this chapter...

- Calibrations
- Adjustments
- Configuration
- Service Diagnostics NVRAM Utilities

Section 6

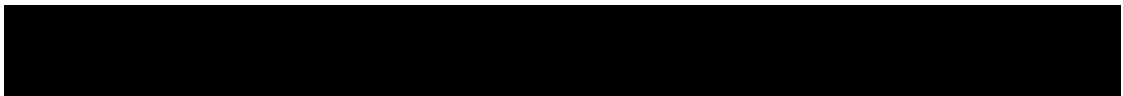

Calibrations

Color Calibration

Color calibration procedures adjust the printer for optimal color output. Color settings may need adjustment:

- On initial printer setup.
- When Toner Cartridges and Imaging Units are replaced.
- When the printer environment changes.
- If the printer has been stored for some time.
- If the printer has not received significant use.

There are two procedures; lighten/darken colors and balance colors.

If the overall image appears either too light or dark, use the lighten/darken colors procedure. If a finer adjustment of the primary colors, cyan, magenta and yellow, is needed, continue with the balance colors procedure.

Print the Calibrate Colors Tutorial page from the printer's Control Panel

Troubleshooting --> **Print Quality Problems** menu and follow the instructions detailed on the page.

Margin Calibration

The Calibrate Margins menu allows you to adjust the printer's imaging area relative to the edges of the paper. The imaging area is shown as a dashed rectangle on the front side of the print, the printer will not print outside this rectangle. The dashed rectangle should line up with the solid rectangle printed on the back side of the page. Hold up to strong light for verification.

Print the Calibrate Margins page from the **Troubleshooting** --> **Print Quality Problems** menu and follow the instructions detailed on the page.

Adjustments

Vertical and Horizontal Color Registration

Vertical Color Registration

Vertical color registration adjustment is performed automatically when the Color Registration page is printed or when a different Imaging Unit is detected. No process for manual vertical color registration adjustment is available. See the procedure on (page 5-29) if problems persist with vertical registration. Vertical color registration settings are stored in the Engine Control Board's NVRAM.

Horizontal Color Registration

There are two adjustment options for horizontal color registration, automatic and manual. The values for these settings are stored in the Image Processor Board's NVRAM.

Automatic registration calibration uses the CTD (ADC) Sensor to measure the distance between black in relation to the other colors placed on the Transfer Roller. The accuracy of this process is 2400 dpi (four times more accurate than the manual process). However, if the horizontal registration alignment is too far out of adjustment, the automatic process fails (the sensor does not detect the colors and fails to correctly align the colors). In this case, adjust the horizontal registration manually.

The manual registration calibration process has an accuracy of accuracy of the calibration is 600 dpi. Use this procedure whenever the Laser Unit has been removed or replaced or the automatic process fails.

The Color Registration menu allows you to adjust the printer's cyan, magenta and yellow against black to ensure that the colors are properly aligned. Settings range from -7 to +7 units. (left to right). See the images on the right. Zero(0) indicates the current color registration setting.

Print the Color Registration page from the **Troubleshooting** --> **Print Quality Problems** menu.

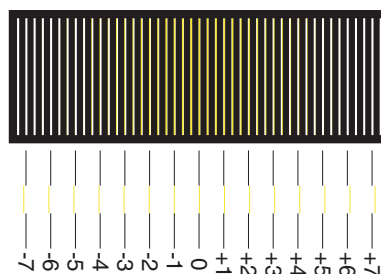
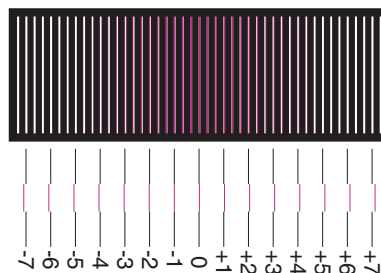
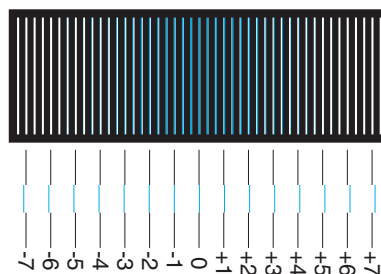

s6300-122

Resetting NVRAM

Printer configuration settings are maintained in the Engine Control Board, the Image Processor Board, and the Configuration Card.

Restore Factory Registration Settings

To reset settings for color registration to the factory-default values:

1. On the Control Panel, select **Troubleshooting**, and then press the **OK** button.
2. Select **Print Quality Problems** menu, and then press the **OK** button.
3. Select **Color Registration**, and then press the **OK** button.
4. Select **Restore Factory Settings**, and then press the **OK** button to reset the color settings to factory defaults.

Restore Factory Color Settings

To reset settings for density and color balance to the factory-default values:

1. On the Control Panel, select **Troubleshooting**, and then press the **OK** button.
2. Select **Print Quality Problems** menu, and then press the **OK** button.
3. Select **Calibrate Colors** menu, and then press the **OK** button.
4. Select **Restore Factory Settings**, and then press the **OK** button.
5. Select **Restore Factory Settings NOW**, and then press the **OK** button to reset the color settings to factory defaults.

Restore Previous Color Settings

To restore the color settings to the ones that existed before you saved the last color balance adjustments.

1. On the Control Panel, select **Troubleshooting**, and then press the **OK** button.
2. Select **Print Quality Problems** menu, and then press the **OK** button.
3. Select **Calibrate Colors** menu, and then press the **OK** button.
4. Select **Restore Previous Settings**, and then press the **OK** button.
5. Select **Restore Previous Settings NOW**, and then press the **OK** button to reset the color settings to the previously set values.

Restore Factory Margins Settings

You can reset margin settings to the factory-default values.

Caution

Use caution when resetting your margins to the factory-default settings. Changing these settings back to factory defaults may not be the last-saved settings if you have previously calibrated your margins.

1. On the Control Panel, select **Troubleshooting**, and then press the **OK** button.
2. Select **Print Quality Problems** menu, and then press the **OK** button.
3. Select **Calibrate Margins** menu, and then press the **OK** button.
4. Select **Restore Factory Settings**, and then press the **OK** button to reset the margin settings.

Resetting Connection Setup Defaults

Resetting the Connection Setup values sets TCP/IP address, TCP/IP address menu settings (gateway, broadcast, etc.), CentreWare IS, EtherTalk, Netware, set IPX frame type, IPP, Ethernet speed, Wait Timeout, Page Description Language, and USB Port selection to their default values.

Caution

Make note of the current network settings or print a Configuration page to provide a record of the customer's current network settings before resetting the connection setup to the factory default values.

1. On the Control Panel, select **Printer Setup**, and then press the **OK** button.
2. Select **Connection Setup**, and then press the **OK** button.
3. Select **Reset Connection Setup**, and then press the **OK** button to reset connection defaults.

Resetting Paper Handling Defaults

Resetting the Paper Handling defaults resets the paper source, 2-sided printing, tray setup, load paper timeout, tray sequence, custom units and jam recovery settings to their default values.

1. On the Control Panel, select **Printer Setup**, and then press the **OK** button.
2. Select **Paper Handling Setup**, and then press the **OK** button.
3. Select **Reset Paper Handling Setup**, and then press the **OK** button.
4. Select **Reset Paper Handling Setup NOW**, and then press the **OK** button to reset the paper handling defaults.

Resetting PostScript Setup Defaults

Resetting the PostScript setup values resets PostScript Error Information, Print-Quality Mode, TekColor Correction, and Image Smoothing, to their default values.

1. On the Control Panel, select **Printer Setup**, and then press the **OK** button.
2. Select **PostScript Setup**, and then press the **OK** button.
3. Select **Reset PostScript Setup**, and then press the **OK** button.
4. Select **Reset PostScript Setup NOW**, and then press the **OK** button to reset the defaults.

Resetting PCL Setup Values to Default

Resetting the PCL setup values resets the default font, pitch, size, symbol set, orientation, form length, and line termination settings to their default values.

1. On the Control Panel, select **Printer Setup**, and then press the **OK** button.
2. Select **PCL Setup**, and then press the **OK** button.
3. Select **Reset PCL Setup**, and then press the **OK** button.
4. Select **Reset PCL Setup NOW**, and then press the **OK** button to reset the defaults.

Resetting Control Panel Setup Values to Default

Resetting the Control Panel Setup values resets the Control Panel language, brightness, contrast and accessibility controls to their default values.

1. On the Control Panel, select **Printer Setup**, and then press the **OK** button.
2. Select **Control Panel Setup**, and then press the **OK** button.
3. Select **Reset Control Panel Setup**, and then press the **OK** button.
4. Select **Reset Control Panel Setup NOW**, and then press the **OK** button to reset the defaults.

Resetting Printer Controls Values to Default

Resetting the Printer Controls values resets the startup page, power saver timeout, low toner warning level, date and time, intelligent ready, metric defaults, and power saver to their default values.

1. On the Control Panel, select **Printer Setup**, and then press the **OK** button.
2. Select **Printer Controls**, and then press the **OK** button.
3. Select **Reset Printer Controls**, and then press the **OK** button.
4. Select **Reset Printer Controls NOW**, and then press the **OK** button to reset the defaults.

Resetting All Printer Defaults (PostScript NVRAM)

Resetting NVRAM returns all the Image Processor Board NVRAM-stored parameters to their factory default values. The print counts and the Adobe firmware serial number are not affected by this reset.

1. On the Control Panel, select **Troubleshooting**, and then press the **OK** button.
2. Select **Service Tools**, and then press the **OK** button.
3. Select **Reset NVRAM**, and then press the **OK** button.
4. Select **Reset NVRAM and Reset Printer NOW**, and then press the **OK** button to reset all the settings to their factory default values.

Developer Assembly Life Count Resets

Reset Developer Assembly life counts whenever any developer assembly is replaced. Use the following procedure to reset individual Developer Assembly counters and installation dates.

1. On the Control Panel, select **Troubleshooting**, and then press the **OK** button.
2. Select **Service Tools**, and then press the **OK** button.
3. Hold down both the **Up Arrow** and **Down Arrow** buttons until the **Hidden Service** menu displays.
4. Select the **Reset Developer Page Count** for the appropriate Developer Assembly color, and then press the **OK** button. This resets the life count to 100% and installation date to the current date for that color. The display then returns to the **Service Tools** menu.

Maintenance Kit Life Count Resets

Reset the Long Life Maintenance Kit count when the kit has been replaced. Use the following procedure to reset the Maintenance Kit Life counter.

1. On the Control Panel, select **Troubleshooting**, and then press the **OK** button.
2. Select **Service Tools**, and then press the **OK** button.
3. Hold down both the **Up Arrow** and **Down Arrow** buttons until the **Hidden Service** menu displays.
4. Select the **Reset Maintenance Kit**, and then press the **OK** button. This resets the life count on all Developers to 100% and resets the installation dates to the current date. The display then returns to the **Service Tools** menu.

Service Diagnostics NVRAM Utilities

Postscript NVRAM Reset

Resetting the NVRAM restores all printer values stored in the IP controller NVRAM including network, printer setup, job defaults, color, margin, and calibrations to their factory default values. The print counts and the Adobe firmware serial number are not affected by this reset.

1. Enter Service Diagnostics.
2. Select **NVRAM Access**, and then press the **OK** button.
3. Select **PostScript NVRAM Reset**, and then press the **OK** button.
4. **Resetting NVRAM! Are you sure?** is displayed. Select **Yes**, and then press the **OK** button.

The printer exits Service Diagnostics and reboots. While booting, NVRAM is reset.

Engine Control Board NVRAM Save/Restore

Save Engine NVRAM

Stores critical Engine Control Board parameters, obtained from currently installed Engine Control Board, to the Image Processor Board's NVRAM. Use this utility to preserve existing NVRAM data in a defective Engine Control Board before removal. A successful operation is indicated when the message **Controller NVRAM write confirmed** displays.

Restore Engine NVRAM

Restores critical Engine Control Board parameters from the Image Processor Board's NVRAM to the replacement Engine Control Board after installation. It is assumed that the Save Engine NVRAM function has previously been performed. A successful operation is indicated when the message **Engine Parameters Restored** displays.

Toner Cartridge Install Date

Displays the installation date currently stored in the Toner Cartridge CRUM. This utility sets the month, day and year and writes the new value to the CRUM. The display updates to reflect the new settings.

Use this utility when the current installation date is corrupt, or the current installation date is obviously incorrect.

Toner Cartridge CRUM Check

This utility checks the identity of the Toner Cartridges to verify if the cartridge is a genuine Xerox Toner Cartridge. The utility reports **<color> Toner Cartridge is not a genuine Xerox product** on the first improper Toner Cartridge detected. Otherwise, **Genuine Xerox Toner** displays.

CRU Life Reset

Sets the life count of the following components to Zero. The display updates to reflect the revised status of the life count.

- Transfer Roller Life

Note

This function also resets the Transfer Roller installation date.

- Cyan, Magenta, Yellow, and Black Developer Life

Note

These functions reset the developer life count only. Use the utilities provided in the Hidden Service menu to reset the developer life count and install date.

CRU Life Read

Displays current life count of the Toner Cartridges, Developer Assemblies, Fuser, Imaging Unit, and Transfer Roller. CRU Life Read also provides the option to display the current Total Page Count.

Read Printer Page Count

Displays the current Total Page count. A simplex page increments the count by one. A duplex page increments the count by two. Pages do not necessarily represent marked pages.

Imaging Unit

Although the Imaging Unit is treated as a single logical component, it has five sub-units each with an individual life count. The expiration of any of these five sub-unit life counts results in a error requiring Imaging Unit replacement.

Fuser Life

Displays the life count from Engine Control Board NVRAM. Units are sheets.

Cleaning and Maintenance

In this chapter...

- Recommended Tools
- Cleaning Procedures
- Routine Maintenance Procedures
- Long Life Maintenance Kit Installation

Section 7

Service Maintenance Procedures

Perform the following procedures whenever you check, service, or repair a printer. Cleaning the printer, as outlined in the following steps, assures proper operation of the printer and reduces the probability of having to service the printer in the future.

The frequency of use, Average Monthly Print Volume (AMPV), type of media printed on, and operating environment are factors in determining how critical cleaning the machine is and how often it is necessary. Record the number of sheets printed.

Recommended Tools

- Toner vacuum cleaner
- Clean water
- Clean, dry, lint-free cloth
- Black, light protective bag

Cleaning

Perform the following general cleaning steps as indicated by the printer's operating environment.

Caution

Never apply alcohol or other chemicals to any parts in the printer. Never use a damp cloth to clean up toner. If you remove the Imaging Unit, place it in a light protective bag or otherwise protect it as exposure to light can quickly degrade performance and result in early failure.

1. Record number of sheets printed.
2. Print several sheets of paper to check for problems or defects.
3. Turn off the printer.
4. Remove the Toner Cartridges, Imaging Unit, and side covers before cleaning.
5. Remove the Front Cover and clean the Fuser Fan to remove excess dust.
6. Remove the Rear Cover and clean the Rear Fan with a brush or dry cloth.
7. Ensure that all cover vents are clean and free of obstructions.
8. Remove any debris or foreign objects from the Transfer Roller, Fuser, and Imaging Unit.
9. Vacuum loose toner from the printer interior using a Type II toner vacuum only.
10. Remove and clean the paper trays.
11. Clean all rubber rollers with a lint-free cloth slightly dampened with cold water.

Cleaning the Imaging Unit

1. Open Door A and Door C.
2. Remove the Imaging Unit and place it rollers-up on a stable surface.
3. Working quickly to reduce light exposure, clean each rubber roller of foreign matter using a lint-free cloth. Thoroughly clean the entire surface of each roller by rotating the roller using the grey thumbwheel.

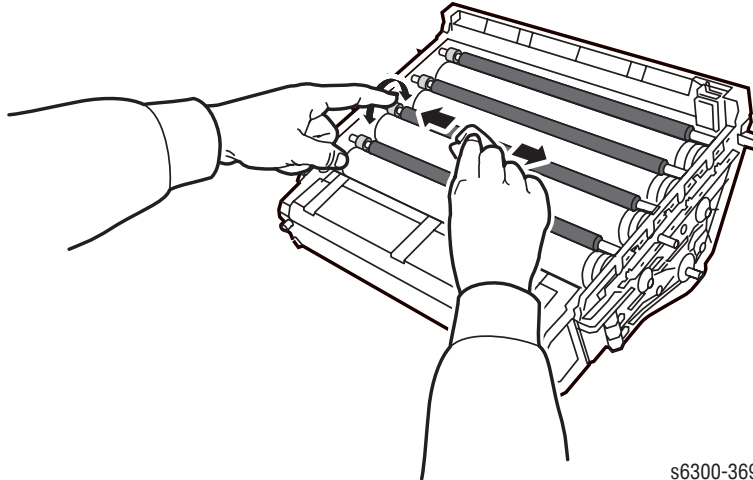

Cleaning the Developer Assemblies

1. Open Door A and Door C.
2. Remove the Imaging Unit and place it light-proof container.
3. Using a flashlight, inspect each Developer Roller and gap between each Developer Assembly. Items, such as foam, paper debris, or hair, can cause print quality defects. Using tweezers, carefully remove any such items.

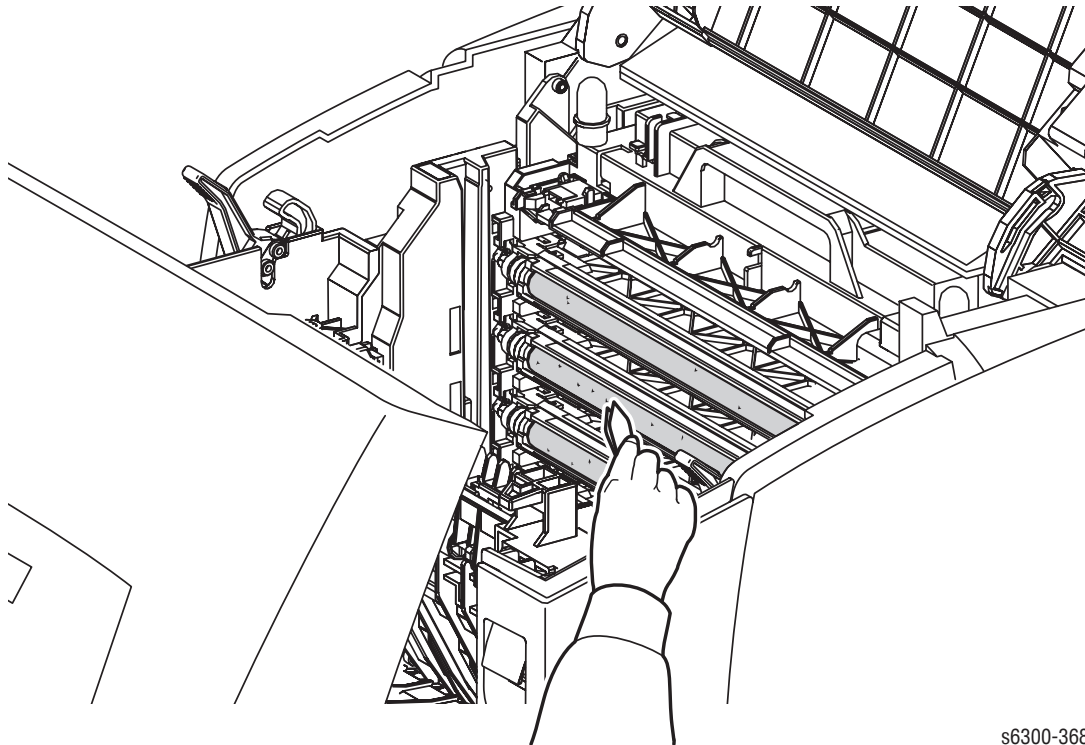

Cleaning the Laser Windows

The four laser windows are positioned behind the Developer Frame Assembly. To clean the windows, remove the Developer Frame Assembly by following the procedure beginning on (page 8-78), and then gently wiping each window with a lint free cloth.

Maintenance

RIP (Repair, Inspect, and Prevent) Procedures

Perform these routine maintenance procedures during the course of servicing the printer.

- Clean the feed rollers, exit rollers, and guides; replace if necessary.
- Remove and clean all paper trays.
- Clean the image density sensor [CTD (ADC) Sensor].
- Print a Status page, diagnose, and repair any problems as indicated.
- Check the print engine and image processor firmware version. Update if necessary.
- Check cleanliness of interior and exterior, including fans; if necessary clean (dust or vacuum) these areas.
- Review proper printer operation using a customer file, if possible. Check with the customer regarding any special applications they may be running.
- Review with the customer all work that was performed; also discuss proper printer care.

Long-Life Maintenance Kit Installation

The Long-Life Maintenance Kit extends printer life up to 600,000 prints. Install the Long-Life Maintenance Kit when the printer displays the Replace Maintenance Kit error message. The Long-Life Maintenance Kit provides these replacement parts:

- Developer Assemblies, PL7.1.17~20
- Registration Roller Assembly, PL4.2.1
- Retard Roller Assembly, PL4.1.13
- Tray 1 (MPT) Feed Roller, PL5.3.20
- Paper Feed Roller Kit, PL2.1.12 and PL3.3.18

Access the Developer Assemblies by removing the Top Main Cover, Right and Left Side Covers, Door C, the Imaging Unit, and the Developer Frame Assembly. Use the following steps to install the Long-Life Maintenance Kit.

Caution

Allow adequate time for the Fuser to cool before servicing the printer.

1. Switch printer power Off and disconnect the power cord.
2. Remove the Top Cover
3. Open the Door A.
4. Open Door C.
5. Remove the Toner Cartridges.

Note

After removal of the Top Main Cover, re-install the Toner Cartridges to reduce the amount of toner spillage and contamination.

6. Remove 2 screws (self-tapping, plastic 10 mm) that secure the Top Main Cover.
7. Release the 2 hooks at the rear of the cover.
8. Hold Door C open slightly. Pull out and remove the Top Main Cover toward the back of the printer.
9. Replace and lock the four Toner Cartridges into their respective holders.

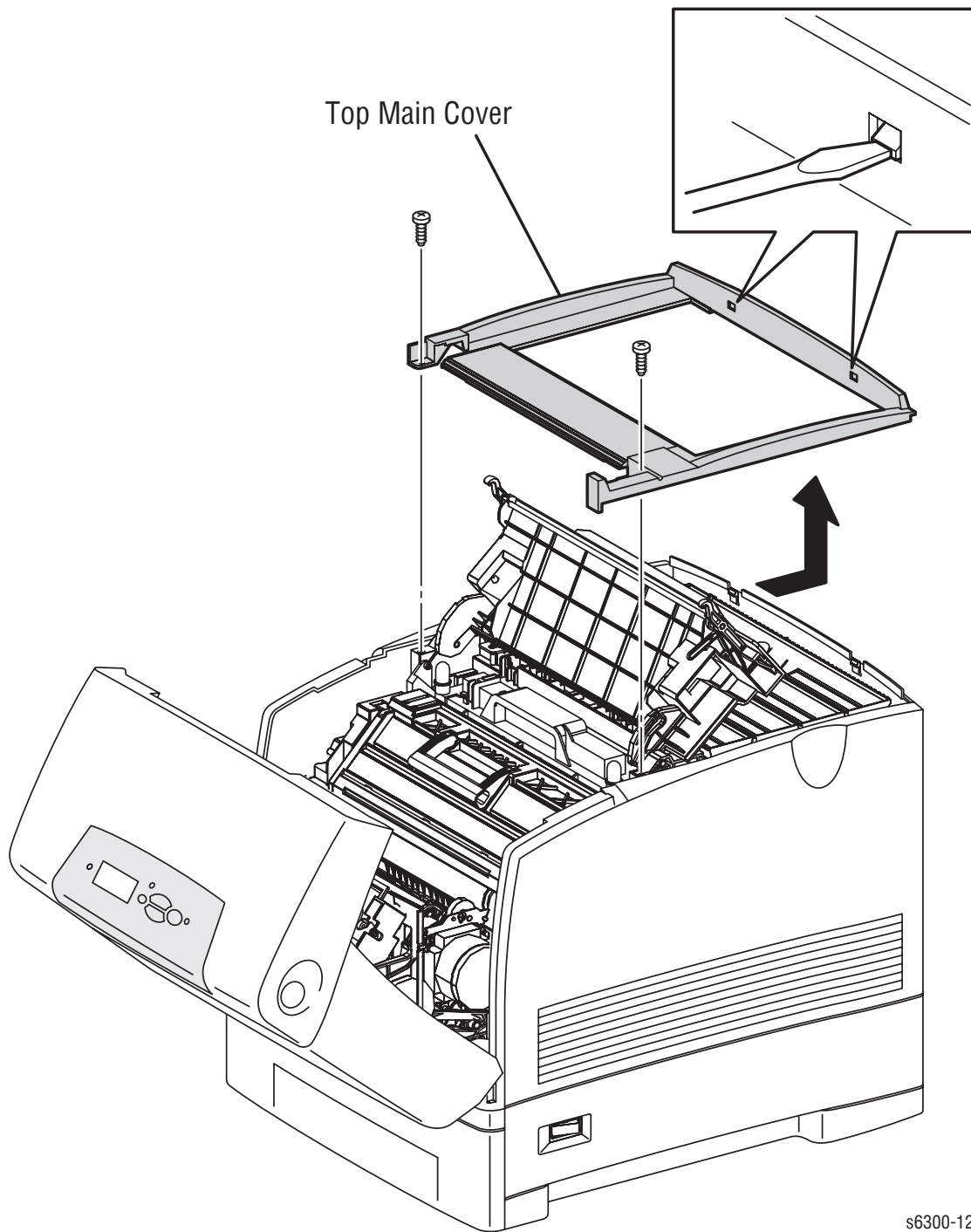

s6300-125

- 10.** Remove the screw (metal, 6 mm) that secures the Right Side Cover.
- 11.** Release the hook at the front that holds the Right Side Cover.

12. Lift the cover and remove it from the printer.

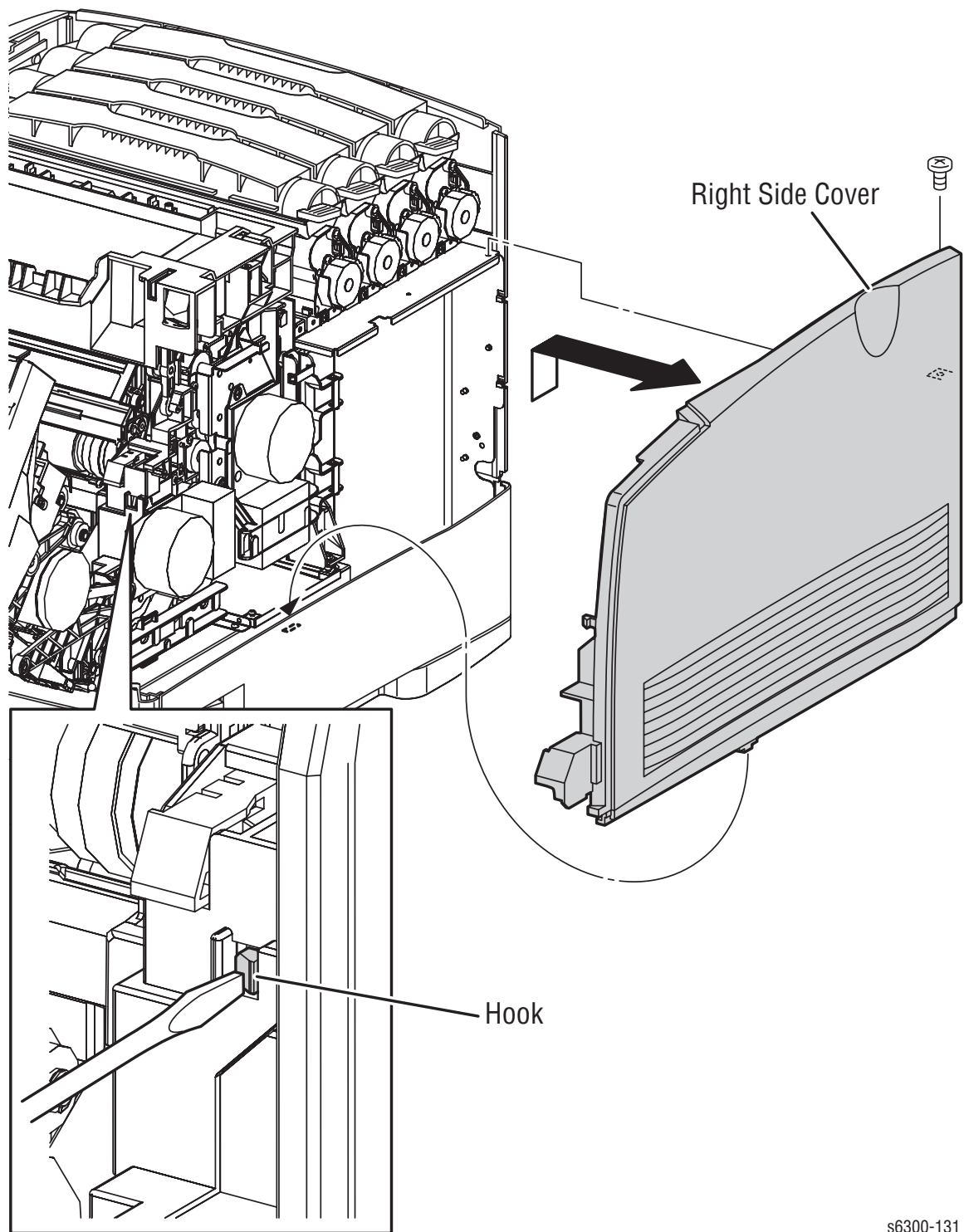

s6300-131

13. Remove the screw (metal with flange, 6 mm) that secures the Left Side Cover.
14. Release the hook on the front that holds the Left Side Cover and slide the cover rearward to remove.

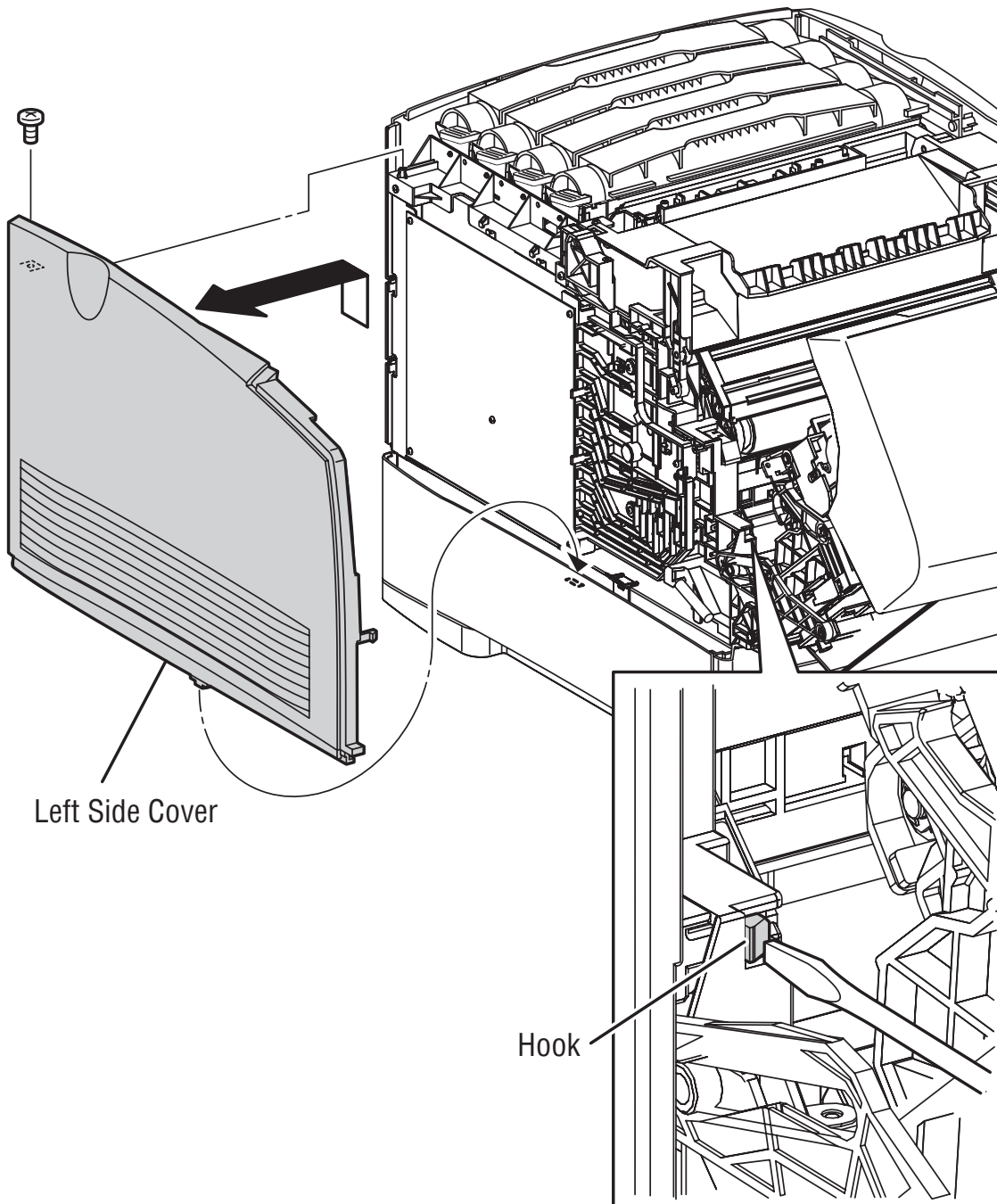

s6300-136

15. Pull out the left and right pins that secure Door C.
16. Spread the bosses on the Developer Frame Assembly guides that fit in the left and right notches of Door C and remove the door.

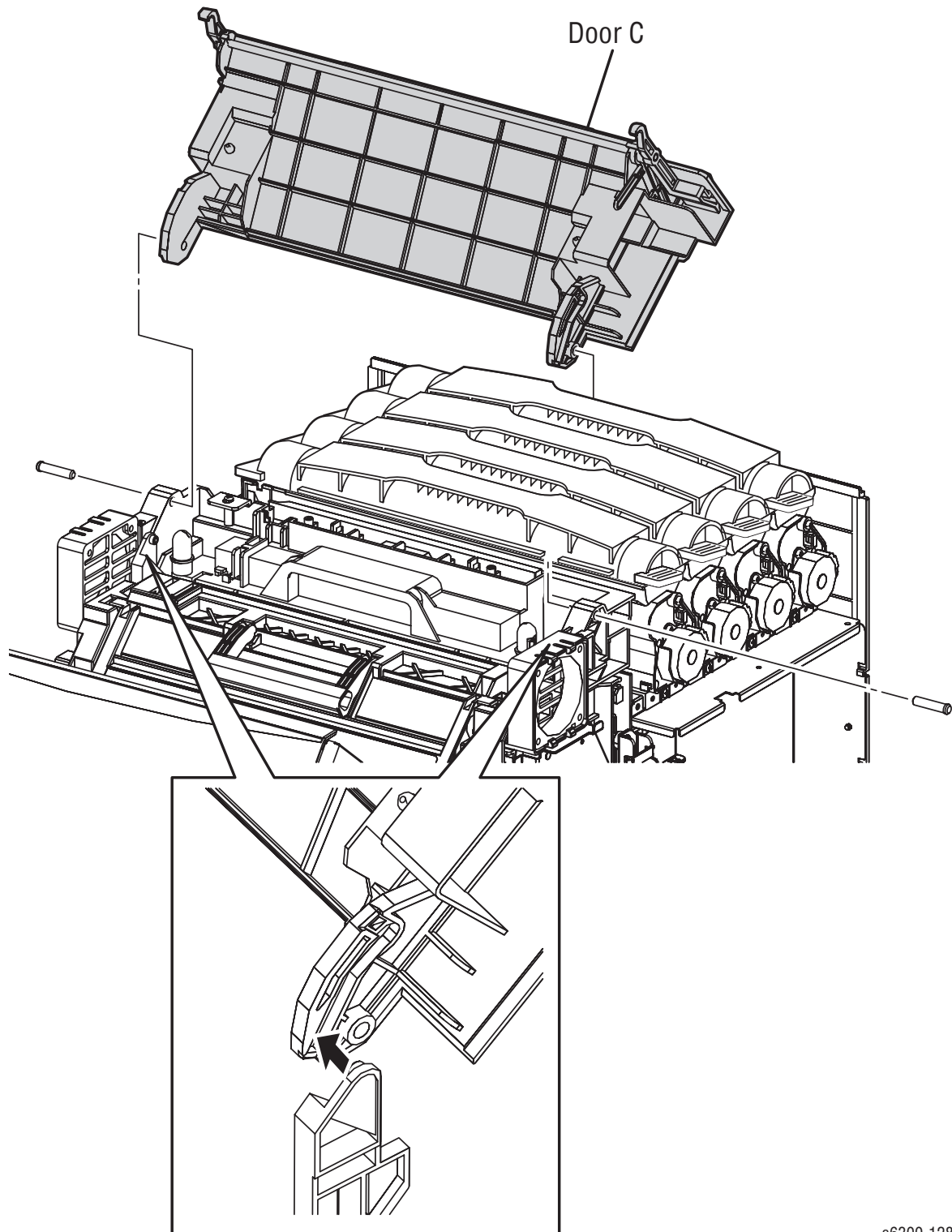

s6300-128

17. Remove the Imaging Unit and place it in a light-proof container.

18. Remove the 2 screws (self-tapping, plastic 10 mm) and 3 screws (metal, 6 mm) that secure the HVPS to the frame.
19. Move the HVPS left to release the retaining hooks on the front edge of the board.
20. Unplug connectors (P/J139, 140, 141) and remove the HVPS.

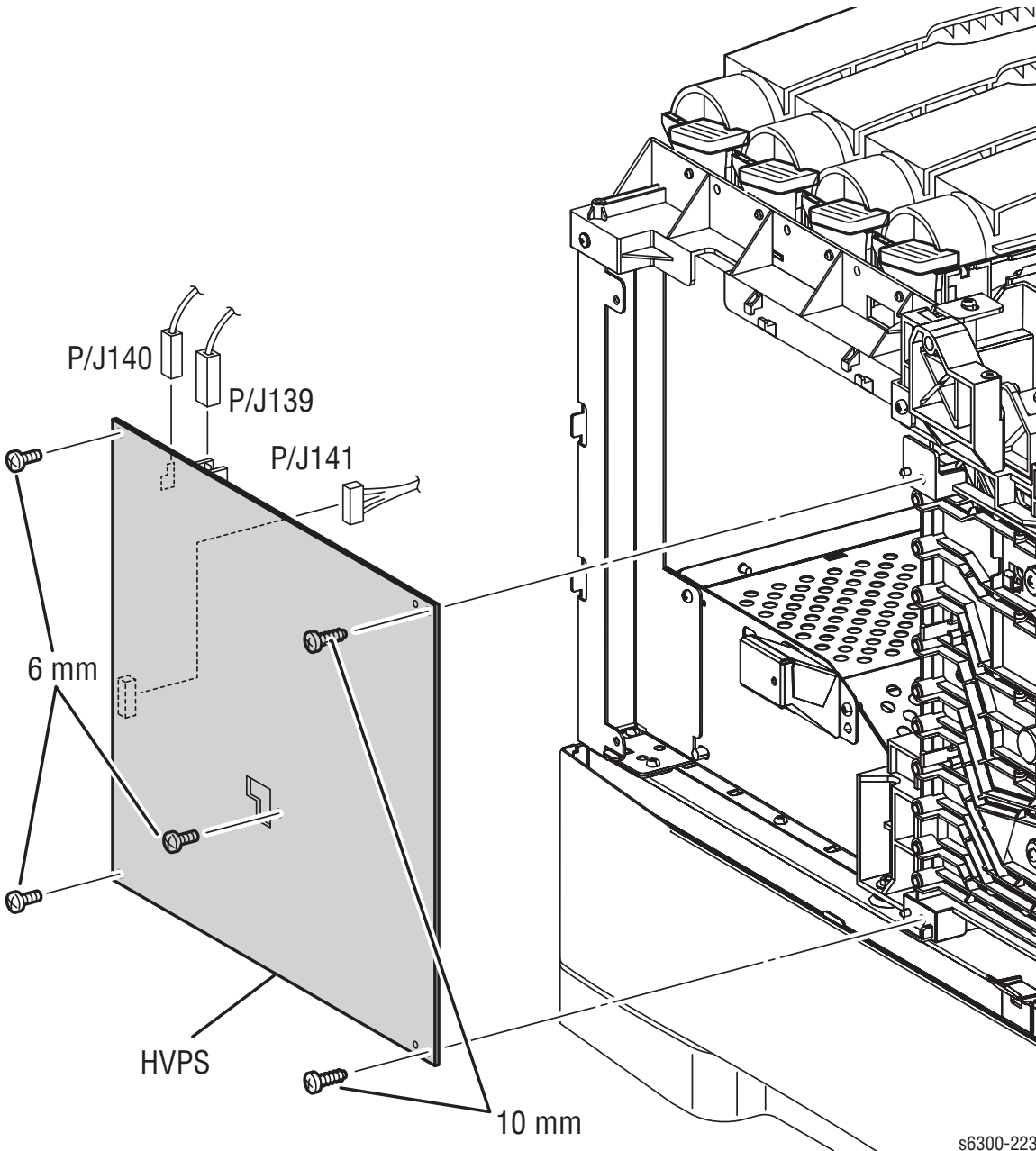

s6300-223

Note

To avoid spilling toner, do not tilt the Developer Frame Assembly backwards (away from the rollers) once it is removed from the printer. Be sure to store the removed Developer Frame Assembly upright on a flat surface with its handle upward.

21. Unplug the Imaging Unit CRUM connector (P/J484) at the top of the Developer Frame Assembly.
22. Release the hooks to disconnect the 4 toner nozzles attached to the Developer Frame Assembly.

Note

Check that the toner nozzle shutter is closed. If the shutter is open; close it immediately.

23. Holding the handle of the Developer Frame Assembly, remove it upward.

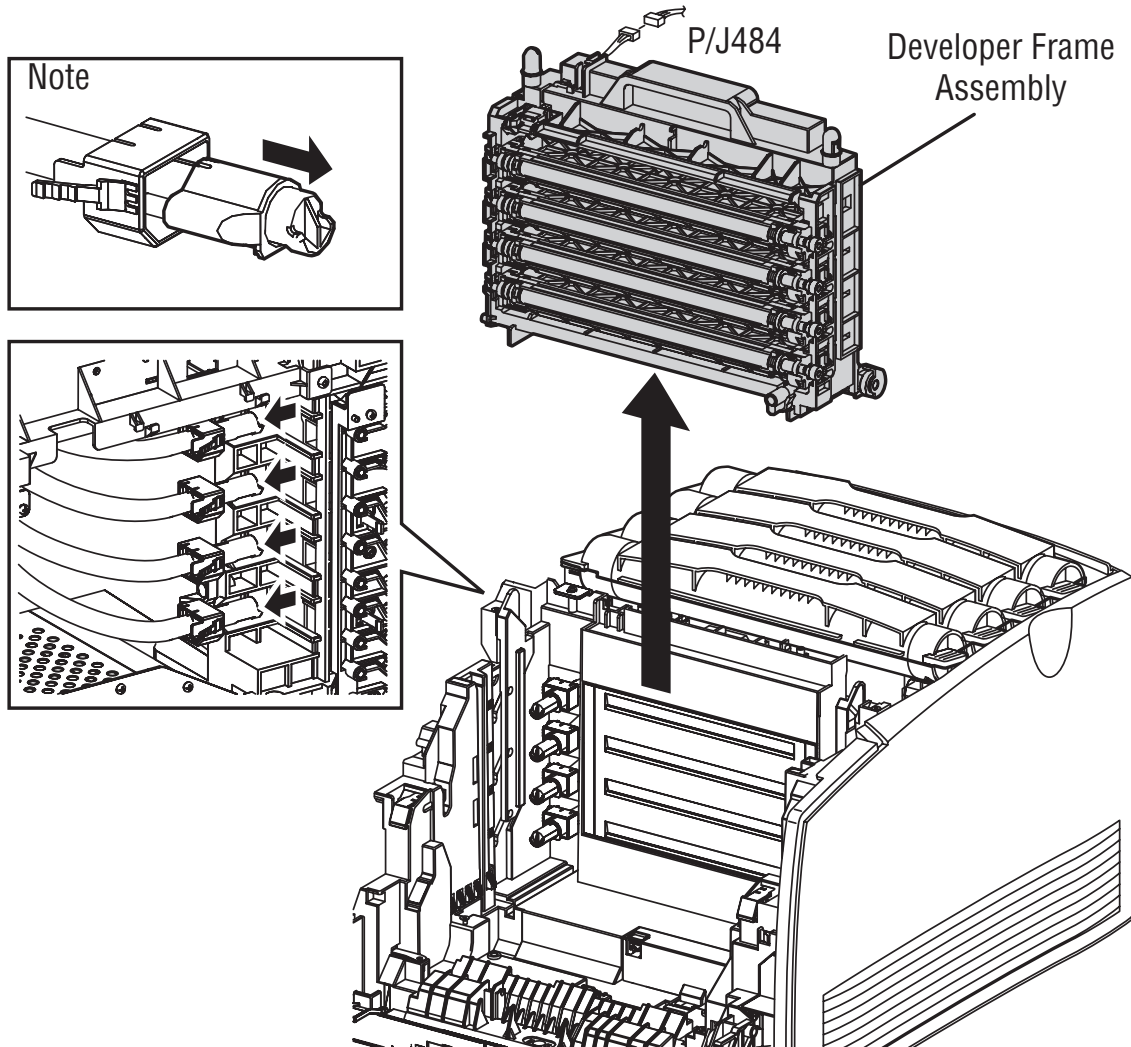

s6300-196

Note

Toner will spill from openings in the Developer Assemblies. Prepare a location to replace the Developer Assemblies by covering a flat surface with paper or other material to capture Toner spilled during the replacement procedure.

24. Open the replacement Developer Assembly packaging and remove the shipping plugs and roller cover from each assembly. Use the plugs, cover and packaging to repack the expended part for return.

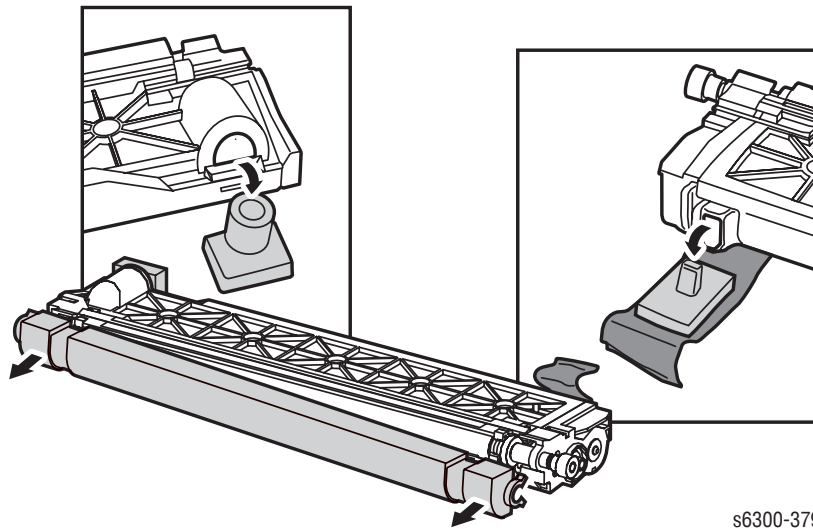

25. Release the left and right white stoppers for each Developer Assembly by sliding each stopper upwards to the unlock position and replace all four Developer Assemblies.

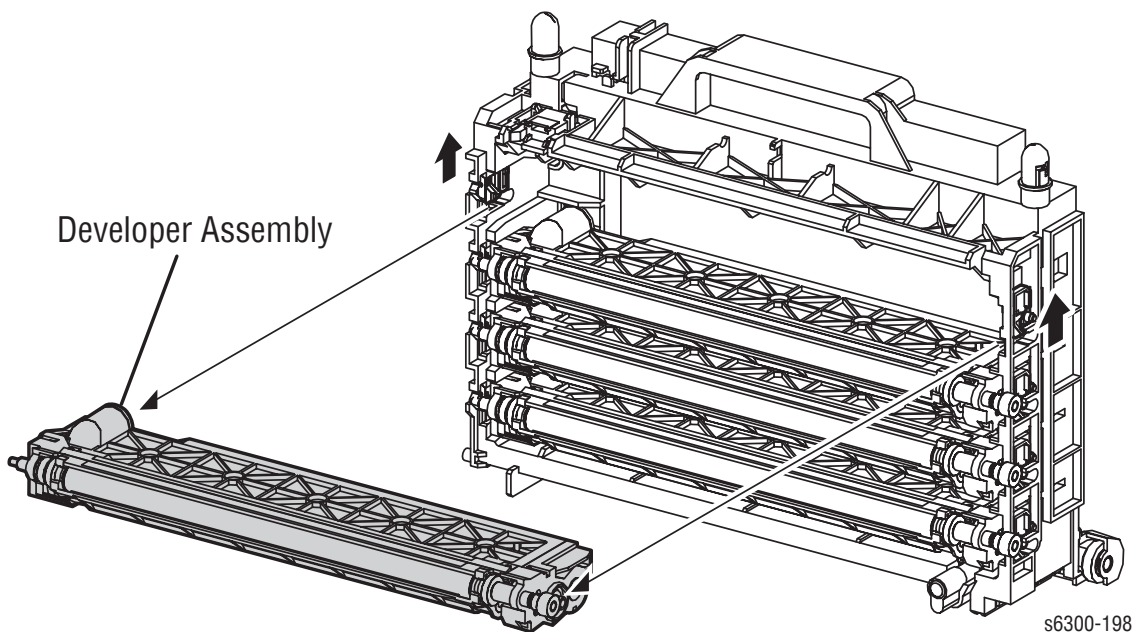

Replacement Note

Inspect each Developer Assembly slot prior to installing the replacement to ensure the left and right tracking spring (PL7.1.13) is securely attached to the Developer Frame Assembly. There should be 2 tracking springs per Developer Assembly.

26. Re-install the Developer Frame Assembly, the HVPS, and Door C.

Replacement Note

Match the colors of the 4 toner nozzles to the correct positions on the Developer Frame Assembly before attaching them.

Before reinserting the pins for Door C, verify that the shoulders on the end of each pin faces out and the bosses on the Developer Frame Assembly guides are set in the notches provided in Door C.

27. Remove 4 screws (self-tapping, plastic 10 mm) that secure the Registration Roller.

Note

Observe the wire routing between the Registration Roller and Engine Control Board. Route the wires in the same manner upon re-installation.

28. Disconnect the two connectors connected to Registration Chute.
29. Move the Registration Roller Assembly to the left and lift it up to remove.

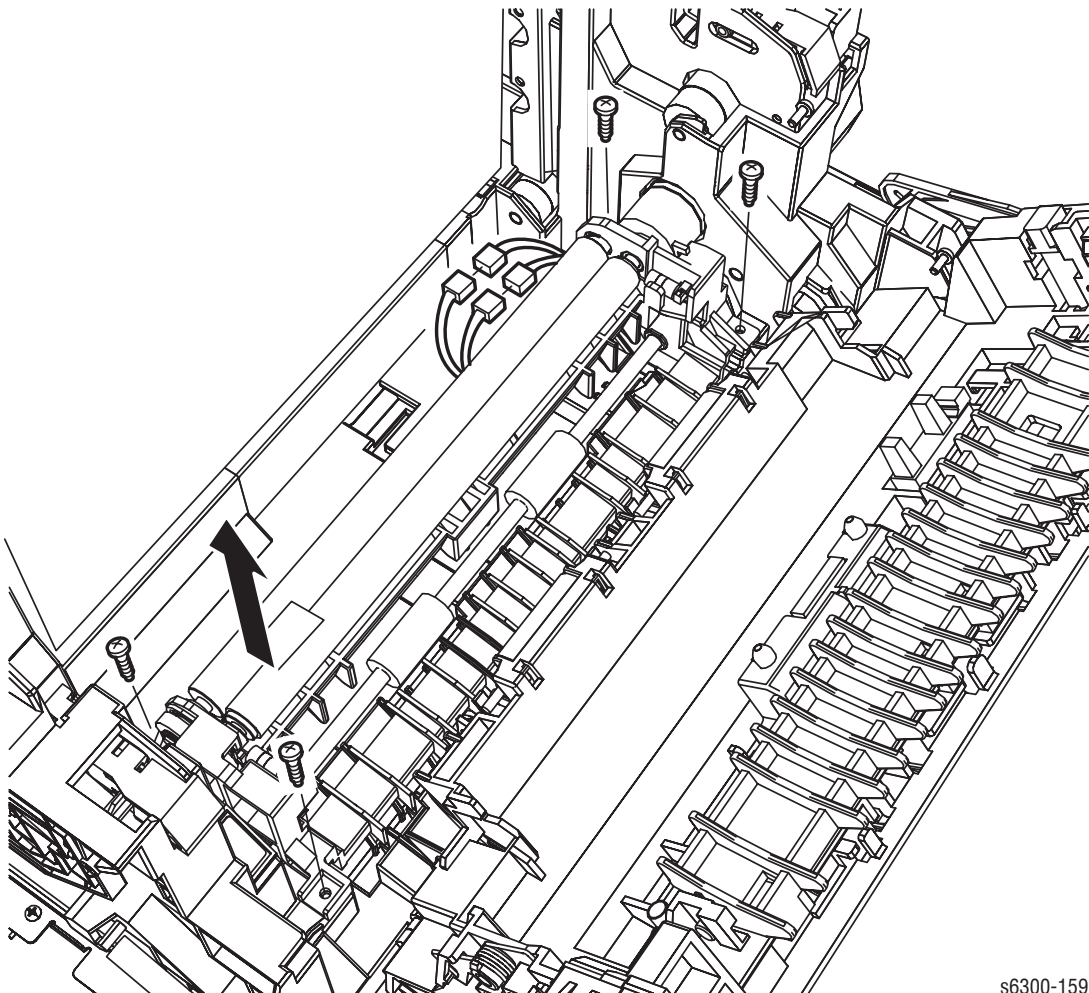

s6300-159

Replacement Note

Be sure to re-install the wiring harness and connectors between the Registration Roller and Engine Control Board as noted in Step 26. Failure to correctly route the wiring can interfere with the Imaging Unit.

Insert the Registration Clutch into the opening first. Lower the opposite end as the Registration and Turn clutches engage the gears.

30. Install the replacement Registration Roller Assembly.
31. Replace the Imaging Unit.
32. Lift the Retard Holder Assembly upward.
33. Move the assembly to the right to release the Retard Roller from the frame and install the replacement.

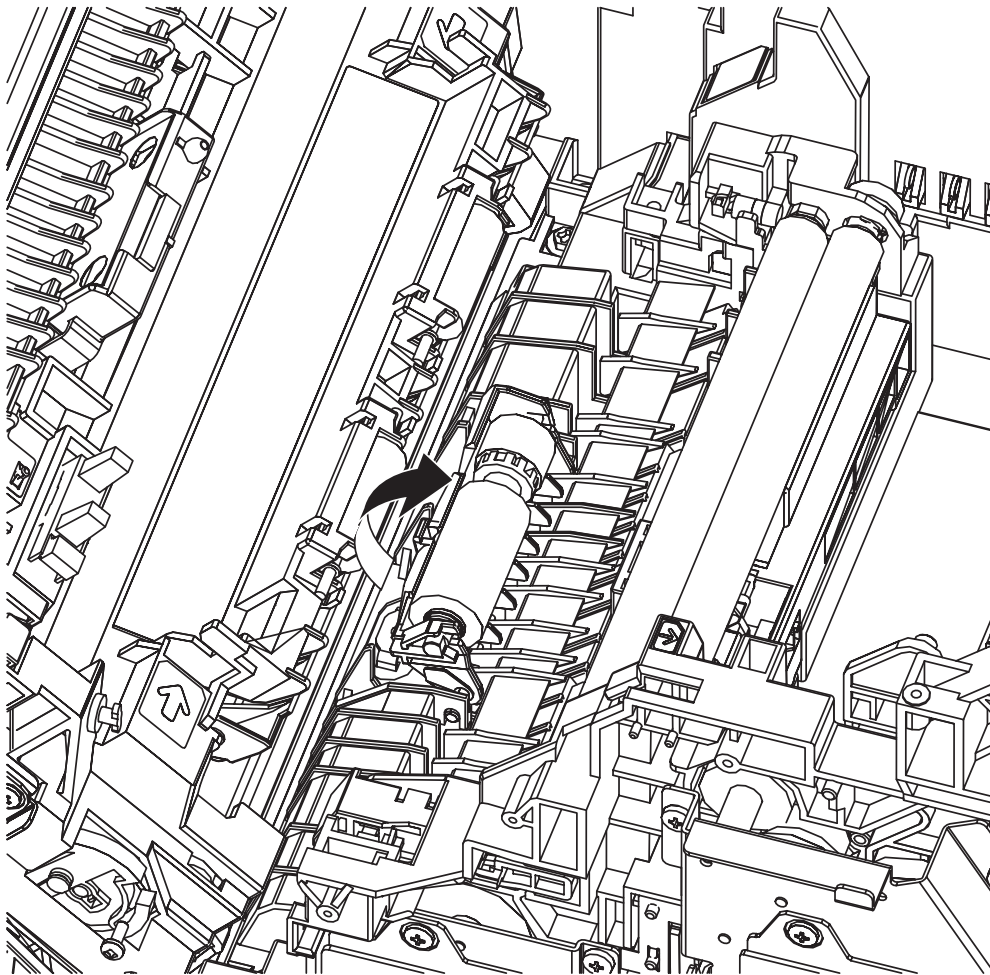

s6300-158

34. Close Door A.
35. Open Door B.

36. Release the 3 hooks that secure the Left Front Cover and remove.

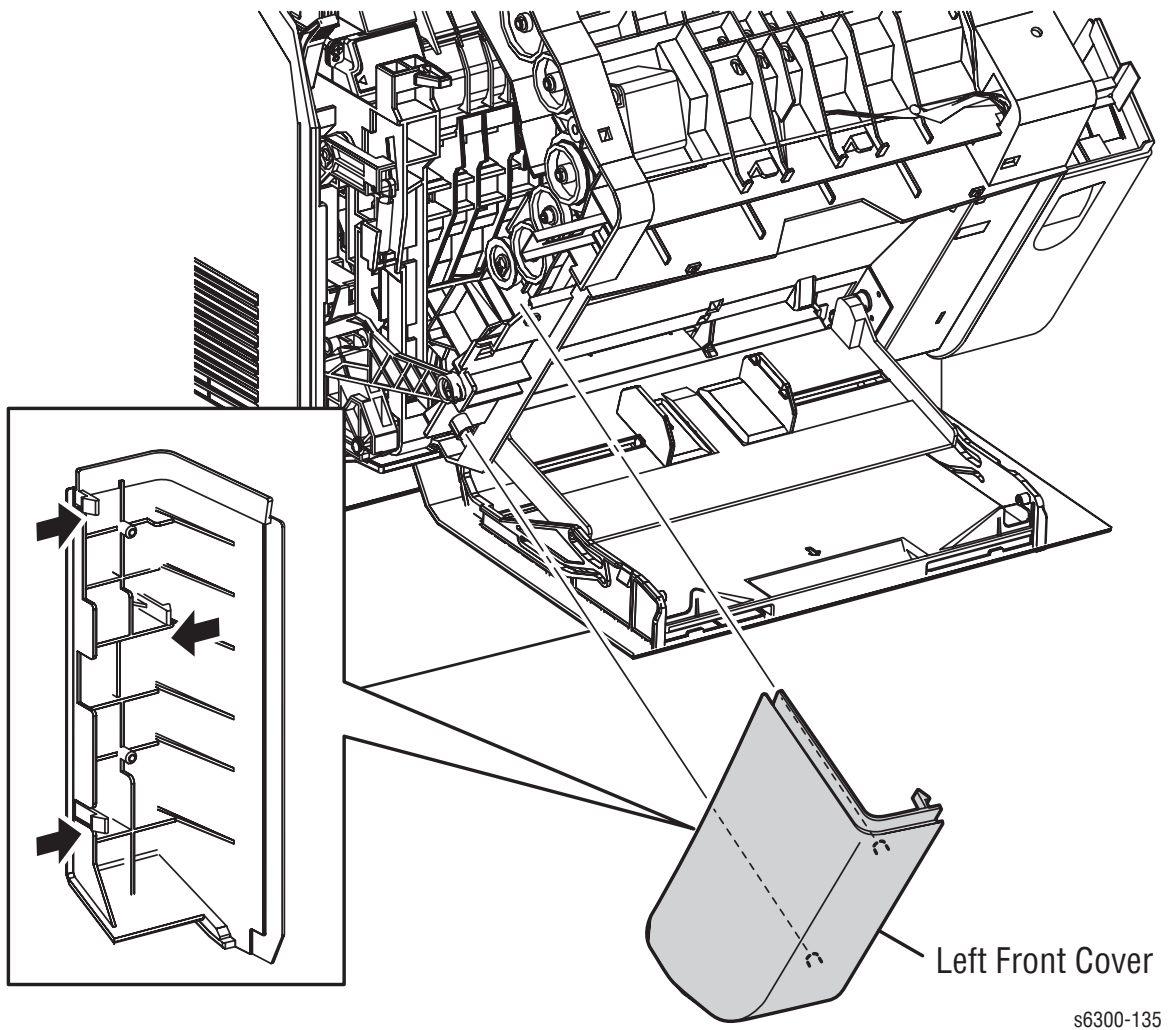

37. Release the hook that secures the nylon Stopper Strap to Door B.

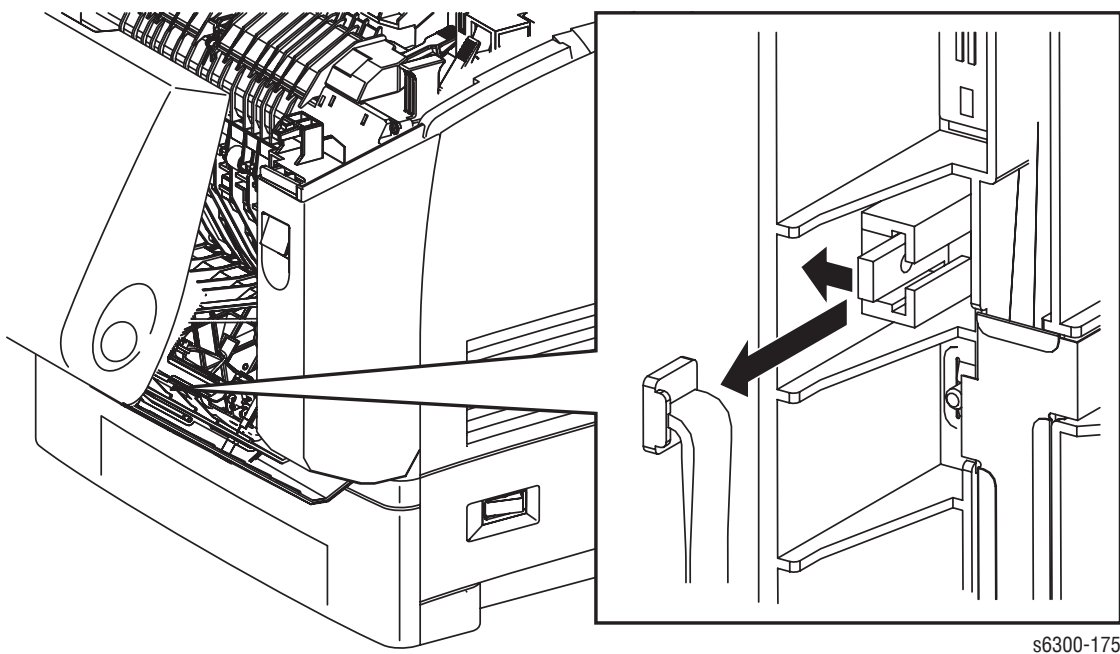

38. Close Door B.

39. Remove the Spring and Link on the left side of the frame.

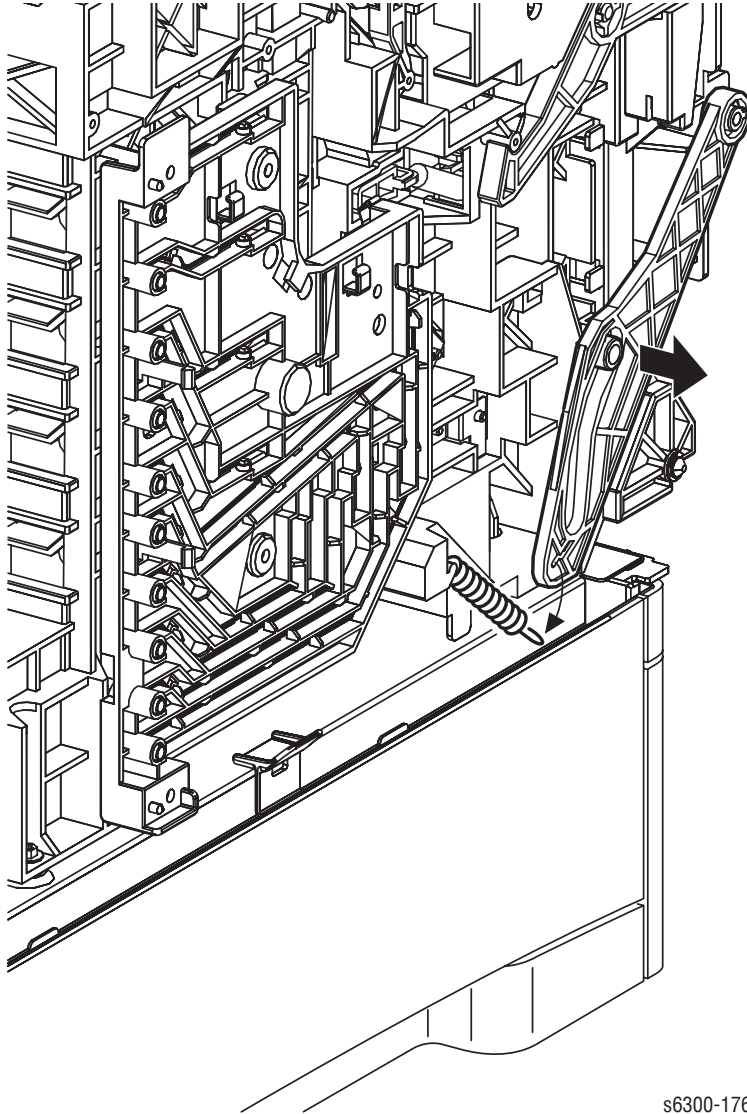

s6300-176

Caution

As you re-open the Door B latch, hold Door B to prevent the door from falling open. Gently lower the door to a supporting surface.

40. Fully open Door B.

41. Release the hook that holds the left side Roll Core retainer on the shaft and slide it to the left.
42. Note the orientation of the Feed Roller and slide the Feed Roller left until the pin on the shaft appears and rotate the Feed Roller to remove it from the shaft.

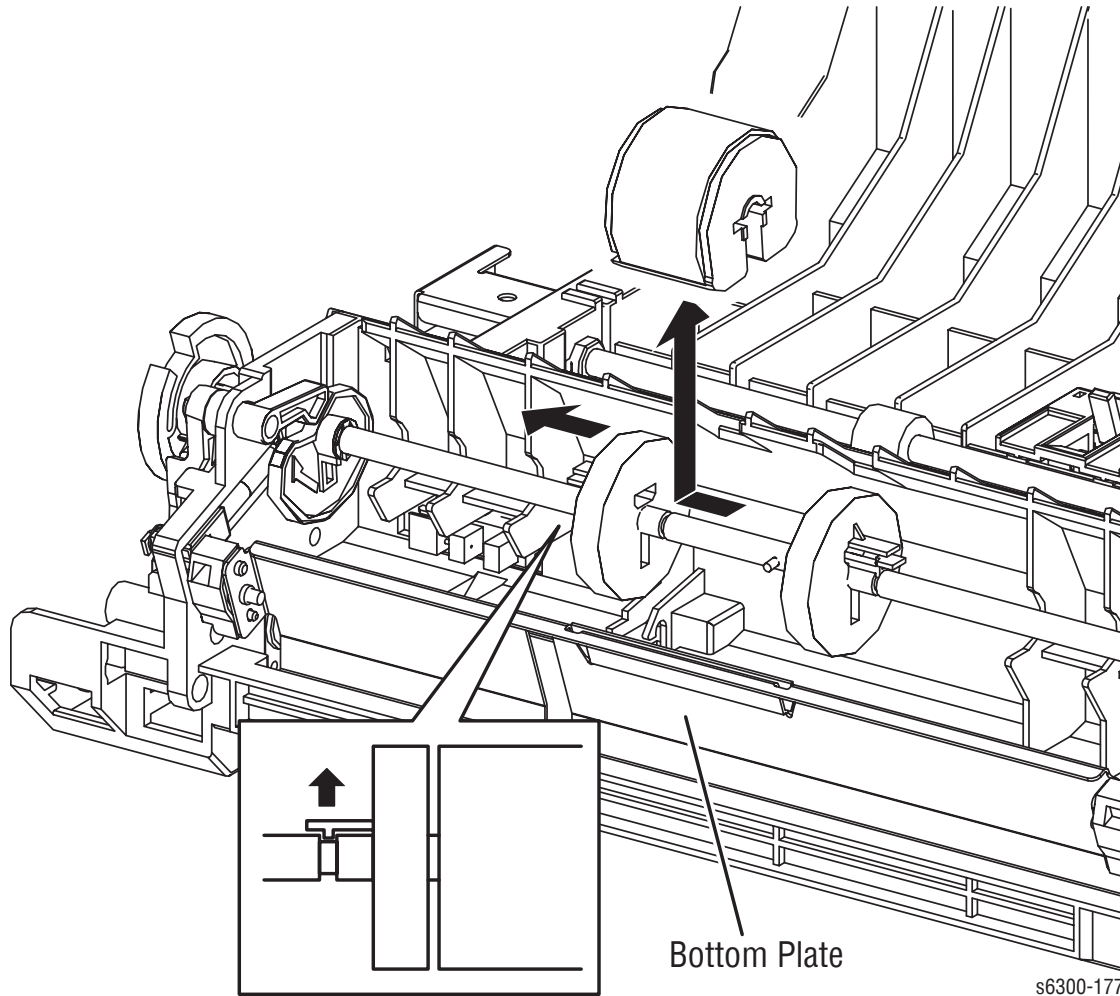

Replacement Note

With the Solenoid engaged, the flat portion of the Feed roller should face the Bottom Plate.

43. Replace the left side Link and Spring, the Stopper Strap, and the Left Front Cover.
44. Close Door B.
45. Remove Tray 2.

46. Release the locks that secure the Feed Rollers to the Feed and Nudger shafts and remove the rollers.
47. Install the replacement rollers and replace the tray.

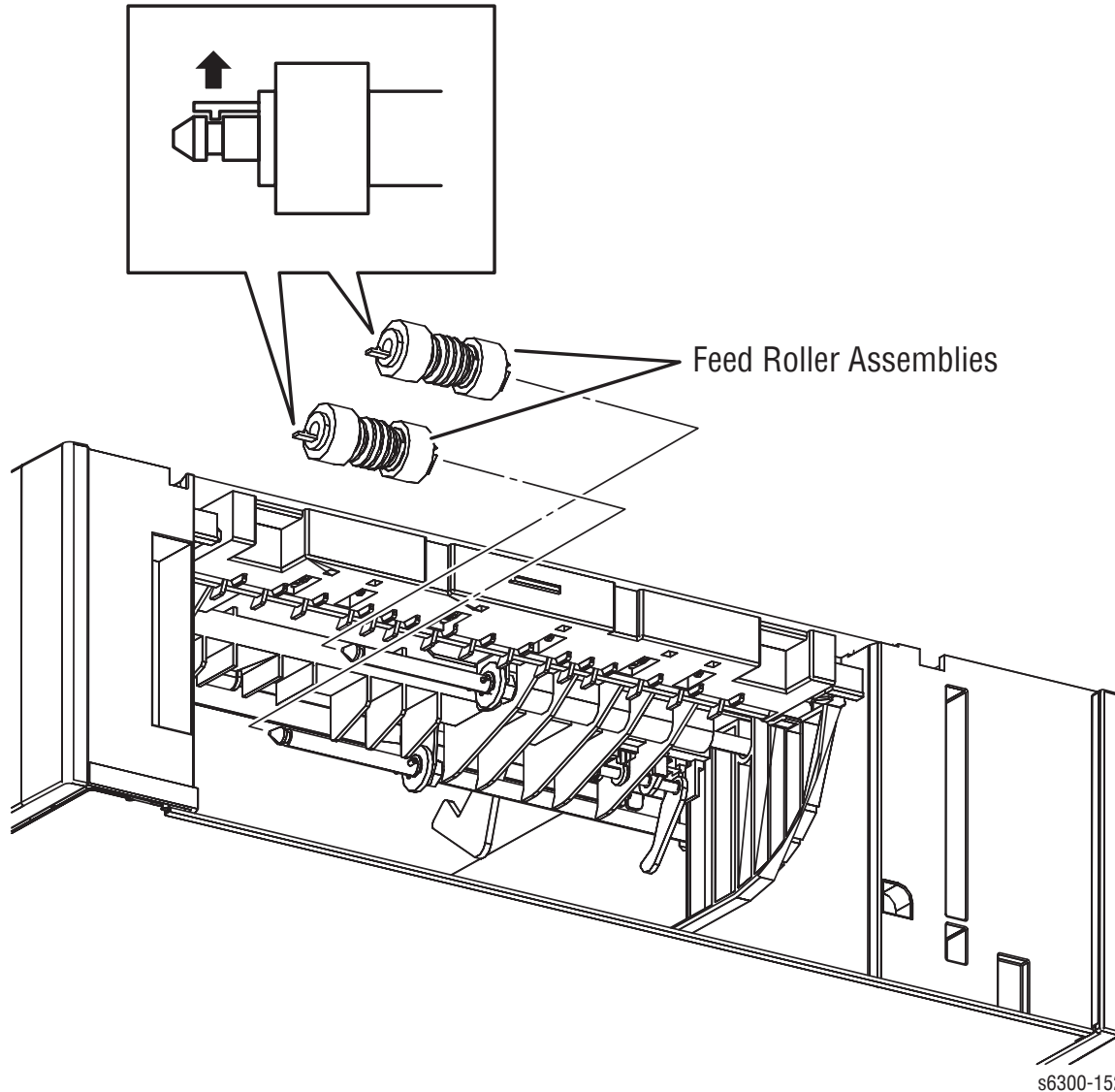

48. Install the Universal Paper Tray Retard Roller Assembly (Part of the Paper Feed Roller Kit).
49. Remove the Toner Cartridges.
50. Replace the Left, Right, and Top Main Covers.
51. Re-install the Toner Cartridges and Top Cover.
52. Reattach the power cord and switch printer power On .
53. Reset the Maintenance Kit Life counter:
 - a. Press **OK** to access the Control Panel menus.
 - b. Select **Troubleshooting** --> **Service Tools**.
 - c. Press the **Up Arrow** and **Down Arrow** buttons simultaneously to access the **Hidden Service** menu.
 - d. Select **Reset Maintenance Kit** to reset the page count and installation date.
54. Test printer operation by printing the Status page.

Service Parts Disassembly

In this chapter...

- Overview
- Removing Routine Maintenance Items and Consumables
- Print Engine Disassembly
- Optional 1100-Sheet Feeder Disassembly
- Optional 550-Sheet Feeder Disassembly

Section 8

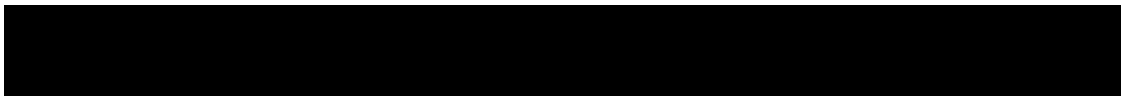

Overview

This section contains the removal procedures for field-replaceable parts of the printer listed in the Parts List. In most cases, the replacement procedure is simply the reverse of the removal procedure. In some instances, additional steps are necessary and are provided for replacement of the parts. For specific assemblies and parts, see the "Parts List" on page 9-1.

Standard Orientation of the Printer

When needed, the orientation of the printer is called out in the procedure as an aid to locating printer parts. Refer to the following figure to identify the right, left, front, and back sides of the printer.

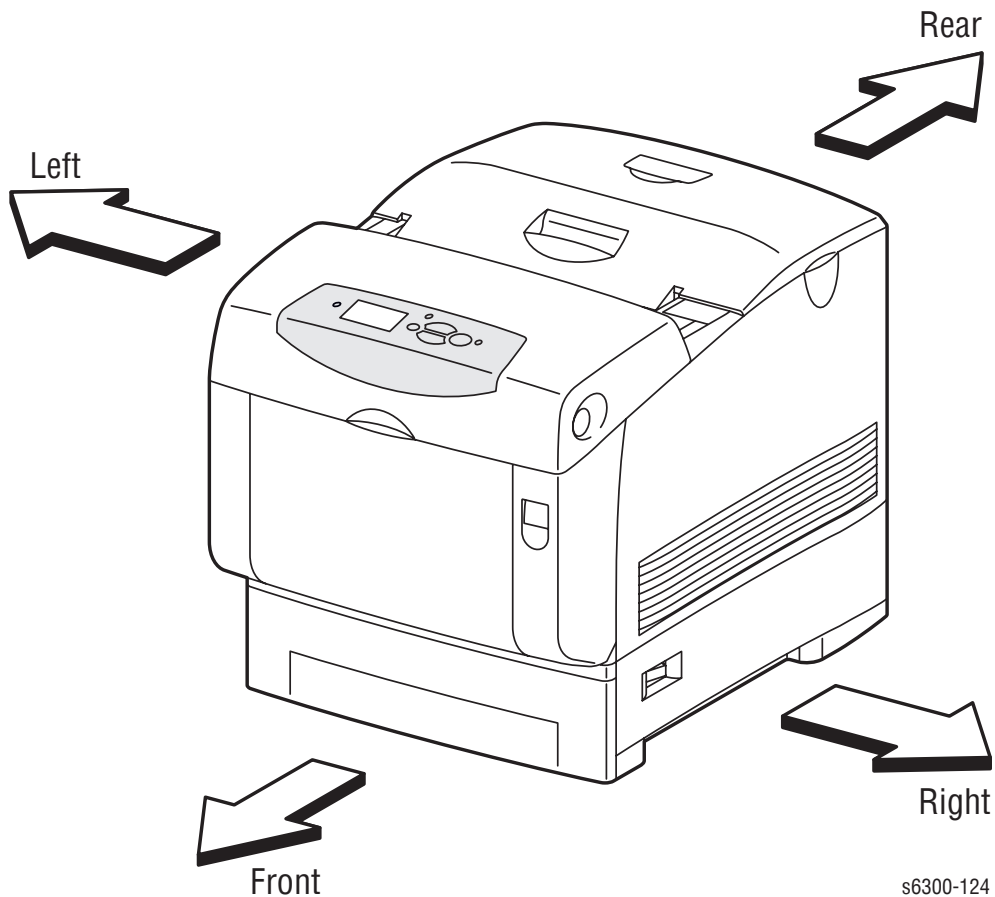

Preparation

Before you begin any removal and replacement procedure:

1. Switch Off the printer power and disconnect the power cord from the wall outlet.
2. Remove the Imaging Unit and protect it from exposure to light by covering it with a light proof bag or by placing it in a light-tight container. Disconnect all computer interface cables from the printer.
3. Wear an electrostatic discharge wrist strap to help prevent damage to the sensitive electronics of the printer circuit boards.
4. Remove the Fuser or wait at least 5 minutes after you have switched Off the printer power for the Fuser to cool before you work on or around the Fuser.

Note

Names of parts that appear in the removal and replacement procedures may not match the names that appear in the Parts List. For example, a part called the Registration Chute Assembly in a removal procedure may appear on the Parts List as Assembly, Chute REGI. When working on a removal procedure, ignore any prerequisite procedure for parts already removed.

Caution

Many parts are secured by plastic tabs DO NOT over Flex or force these parts. Do not over torque the screws threaded into plastic parts.

Always use the correct type and size screw. Using the wrong screw can damage tapped holes. Do not use excessive force to remove or install either a screw or a printer part.

Warning

Unplug the AC power cord from the wall outlet before removing any printer part.

Notations in the Disassembly Text

- The notation “(item X)” points to a numbered callout in the illustration corresponding to the disassembly procedure being performed.
- The notation “PLX.X.X” indicates that this component is listed in the Parts List.
- Bold arrows in an illustration show direction of movement when removing or replacing a component.
- The notation “(self-tapping, plastic 10 mm)” or “(metal, 6 mm)” refer to the type of screw being removed.





Replacement Note

Provides information specific to the replacement of parts or assemblies.

Fastener Types

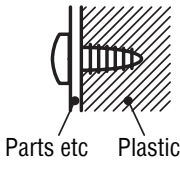
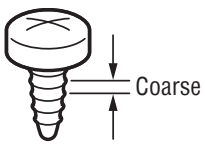
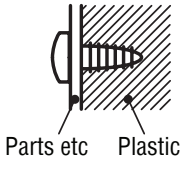
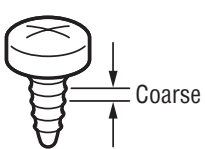
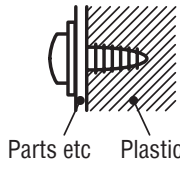
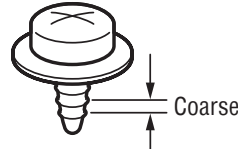
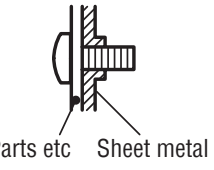
The following table lists the primary types of Posi-Drive screws used to assemble the printer. The procedures provide dimensional specifications for screws being removed.

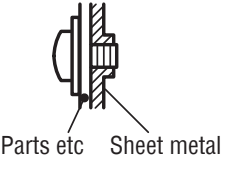
Posi-Drive Screw Types used in the Printer

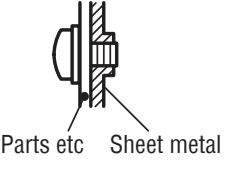
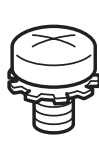
| Type | Application | Shape | Characteristics |
|--------------------------------------|---|---|--|
| Self-tapping, plastic |  |  | <ol style="list-style-type: none"> 1. Silver colored 2. Screw thread is coarse compared to metal screw. 3. Screw tip is thin. |
| Self-tapping, plastic |  |  | <ol style="list-style-type: none"> 1. Black colored 2. Screw thread is coarse compared to metal screw. 3. Screw tip is thin. |
| Self-tapping, plastic with flange |  |  | <ol style="list-style-type: none"> 1. Silver colored 2. It has a flange. 3. Screw thread is coarse compared to metal screw. 4. Screw tip is thin |
| Sheet Metal, silver |  |  | <ol style="list-style-type: none"> 1. Silver colored 2. Diameter is uniform 3. Typically 6 mm in length |
| Sheet Metal, with flange |  |  | <ol style="list-style-type: none"> 1. Silver colored 2. It has a flange. 3. Diameter is uniform |
| Sheet Metal, silver with lock washer |  |  | <ol style="list-style-type: none"> 1. Silver colored 2. Includes a toothed washer 3. Diameter is uniform 4. Used for grounding terminals. |

Caution

Use care when installing self-tapping screws in plastic. To properly start the screw in plastic, turn the screw counter-clockwise in the hole until you feel the screw engage the threads, then tighten as usual. Failure to properly align or over tighten the screw can result in damage to previously tapped threads.

Maintenance Items and Consumables

Maintenance items include the Transfer Roller, Imaging Unit, and Fuser. The Paper Feed Rollers are also routine maintenance items, but individual procedures for their removal and replacement are provided on page 8-20 and page 8-57. Consumables consist of the four toner cartridges.

Transfer Roller Removal

Warning

If the printer has been in operation recently the Fuser may be hot. Be careful when you release the latches on the Transfer Roller not to come into contact with the hot Fuser.

1. Power down the printer.
2. Open Door A.
3. Squeeze the latch at each end of the Transfer Roller and pivot the latch up.
4. Lift the Transfer Roller out of the printer.

Imaging Unit Removal

1. Power down the printer.
2. Open Door A.
3. Open Door C.
4. Grasp the handle on the top of the Imaging Unit and lift it out of the printer.
5. Place the Imaging Unit in a light proof bag or other light proof container.

Caution

Leaving the Imaging Unit exposed to light for periods in excess of a 10 minutes can quickly degrade its performance and result in early failure.

Fuser Removal

Warning

The Fuser may be hot. Turn off power and allow at least 5 minutes for the Fuser to cool before removal.

1. Power down the printer.
2. Open Door B.
3. Lift the Lock Lever on each side of the Fuser, grasp the handles and lift the Fuser straight up off the mounting studs.

Toner Cartridge Removal

Caution

Clean up any toner spills using a Type II Toner Vacuum only. Never use a damp cloth to clean up spilled toner.

If you are removing a Toner Cartridge to facilitate removal of other components, replace the Toner Cartridge as soon as those components have been removed. Keeping the Toner Cartridges locked into place prevents contamination of the toner system and spillage.

1. Power down the printer.
2. Using the lips on both sides, lift the Top Cover (Output Tray) off of the printer.
3. Rotate the locking lever on the end of the cartridge (or cartridges) being removed to the back unlocked (closed) position and lift the cartridge out of the printer.

Note

Some toner adheres to the bottom of the cartridge, so do not set the cartridge on any surface that can be damaged by the toner.

Print Engine Disassembly

Print Engine disassembly is presented in the following procedures organized in the following categories:

- Covers
- Trays
- Feeders
- Retard and Registration
- Input and Output Chute Assemblies
- Xerographics
- Development
- Drive
- Electrical

For convenience, it is recommended that you remove the Top Cover, Imaging Unit, and trays and place them where they do not interfere with the repair. (Note that servicing can be done with these parts in place depending on the location of the procedure being performed.) Also, cover the exposed rollers of the Developer Assemblies with a sheet of paper or other similar material to avoid the transfer of Toner to clothing or other parts of the printer.

Caution

Do not expose the Imaging Unit to light for more than 10 minutes. After removal, cover the Imaging Unit to minimize the amount of light striking the rollers. Prolonged exposure to light significantly reduces Imaging Unit performance.

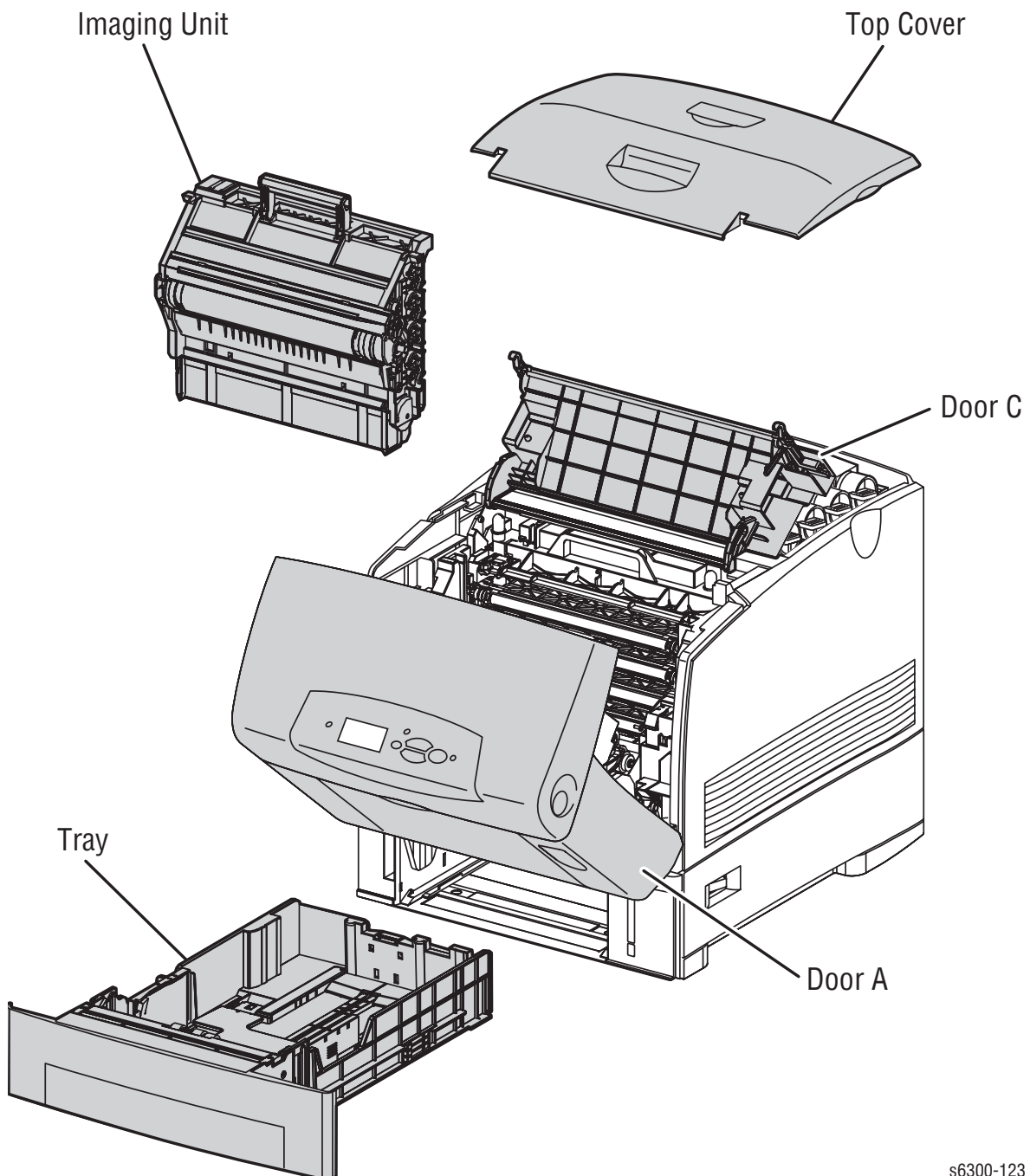

s6300-123

Covers

Top Main Cover (PL1.1.4)

1. Remove the Top Cover.
2. Open the Door A.
3. Remove the Toner Cartridges.
4. Open Door C.
5. Remove 2 screws (self-tapping, plastic 10 mm) that secure the Top Main Cover.
6. Release the 2 hooks at the rear of the cover.
7. Hold Door C open slightly. Pull out and remove the Top Main Cover toward the back of the printer.

Note

After removal of the Top Main Cover, replace the Toner Cartridges to reduce the amount of toner spillage and contamination.

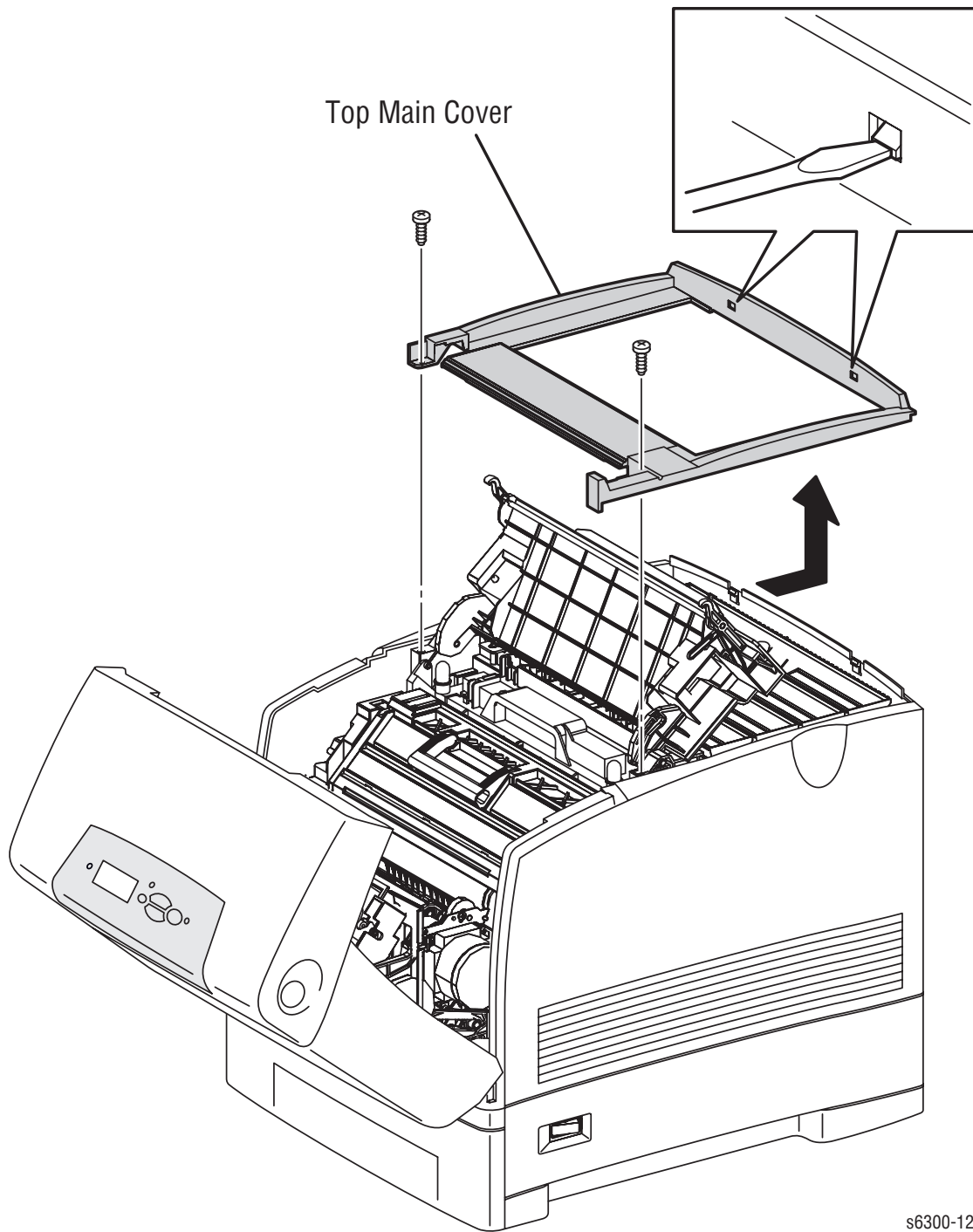

Front Cover (PL1.1.6)

The Control Panel harness is connected between the Front Cover and Door B. Be careful not damage the harness while removing the cover. Also, the Upper Exit Cover is not captive to the Chute Assembly Out and can fall as the Front Cover is removed.

1. Open Door B.
2. Remove 2 screws (self-tapping, plastic 10 mm) that secure the Front Cover to Door B.
3. Release the 4 hooks that secure the Front Cover to Door B.
4. Unplug connector (P/J220) from the Control Panel. and remove the Front Cover.

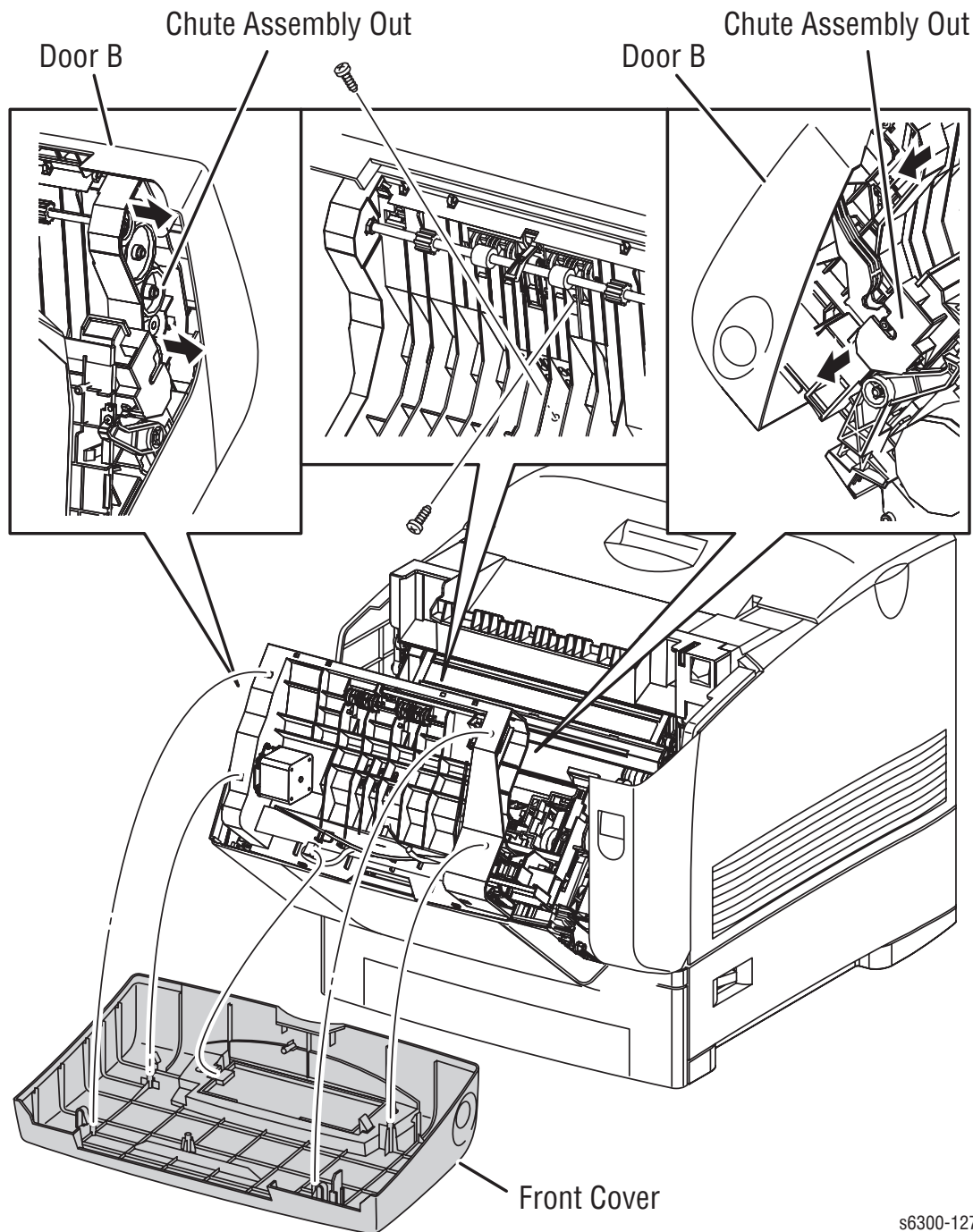

s6300-127

Control Panel (PL1.1.5)

1. Remove the Front Cover (page 8-10).
2. Release the 2 hooks that secure the Control Panel to the Front Cover.

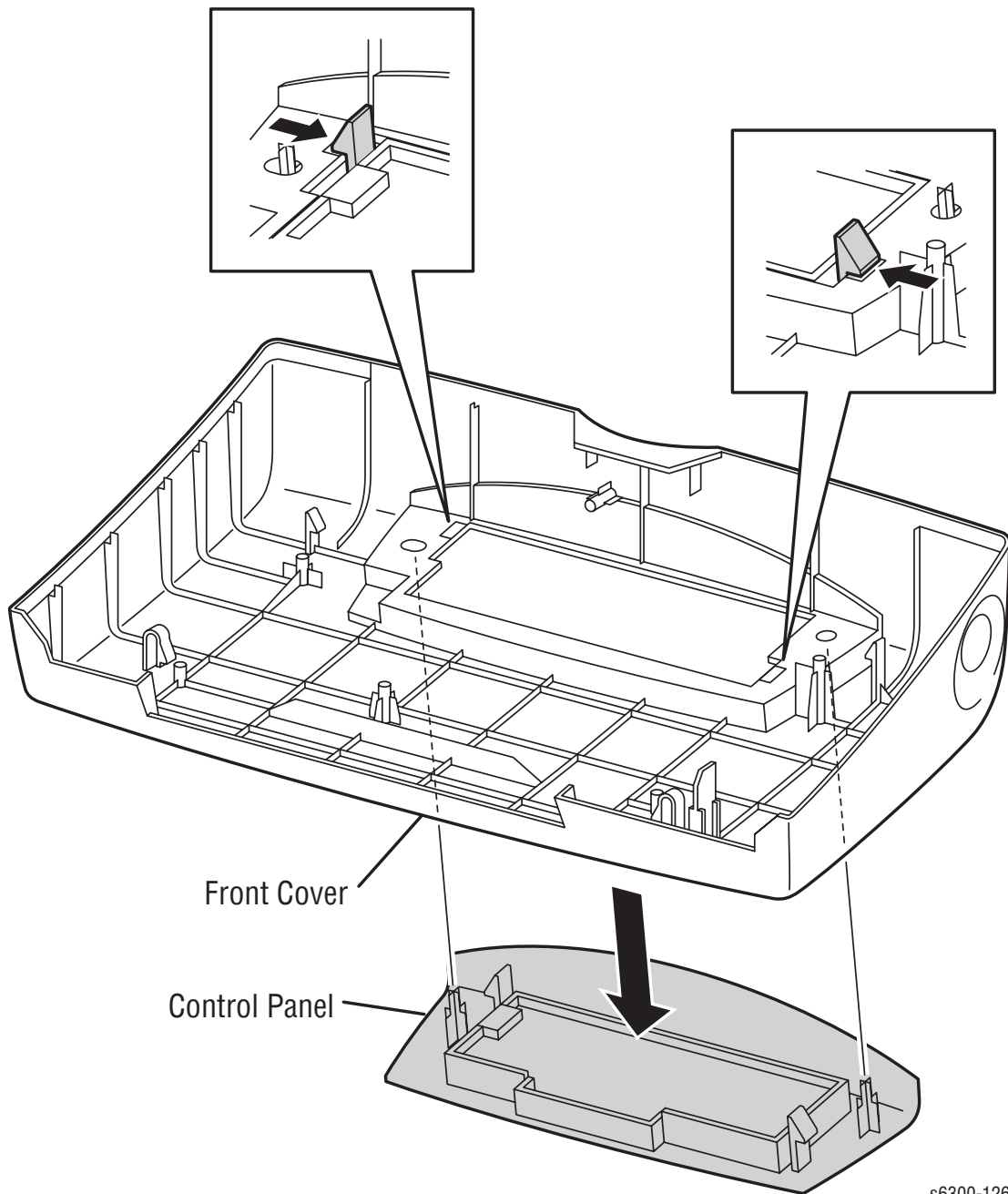

Right Side Cover (PL1.1.20)

1. Remove the Top Main Cover (page 8-8).
2. Open Door A.
3. Remove the screw (metal, 6 mm) that secures the Right Side Cover.
4. Release the hook at the front that holds the Right Side Cover.
5. Lift the cover and remove it from the printer.

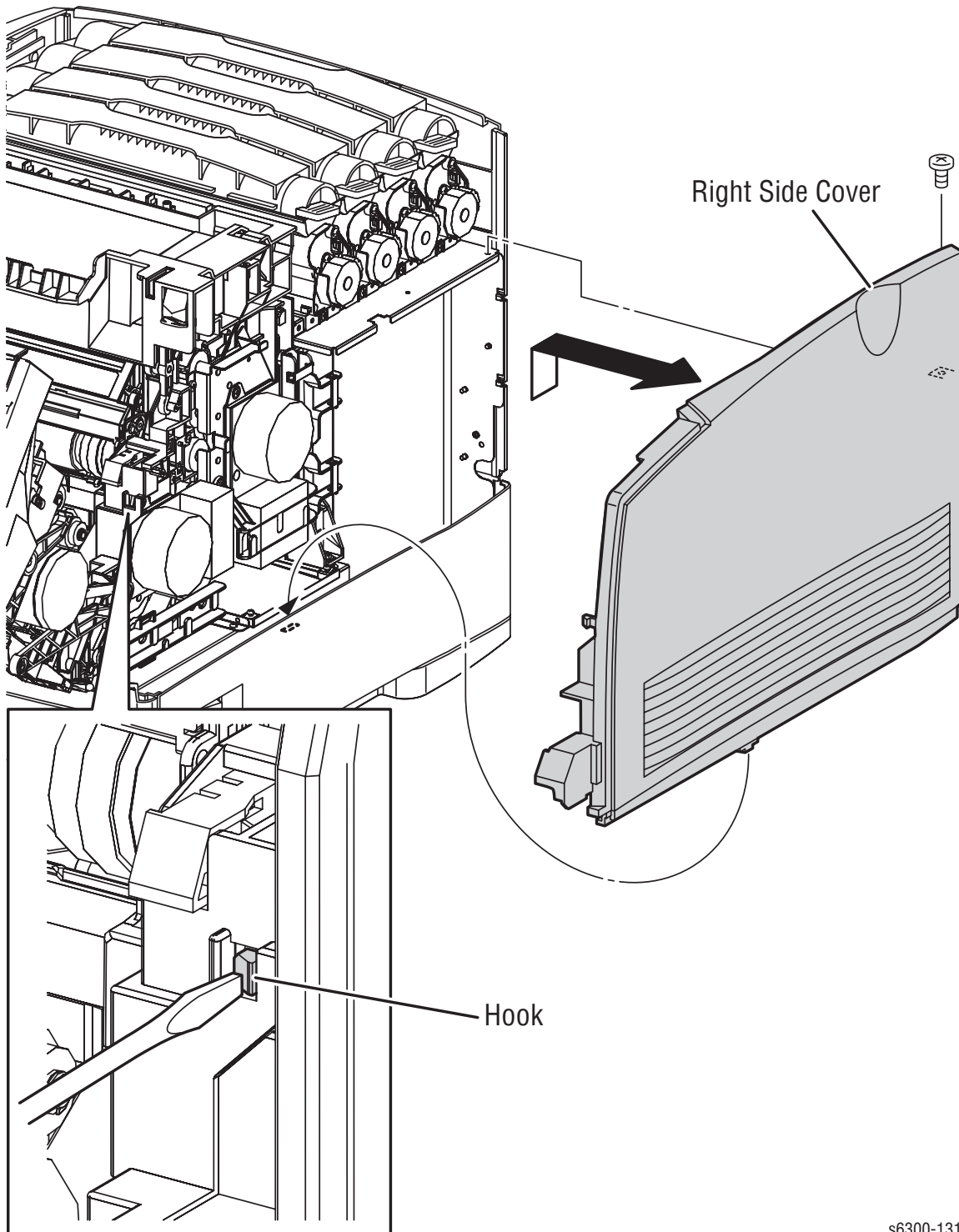

s6300-131

Left Side Cover (PL1.1.30)

1. Remove the Top Main Cover (page 8-8).
2. Remove the screw (metal, 6 mm) that fixes the Left Side Cover.
3. Slide the cover rearward to release the hook on the front that also holds the Left Side Cover and remove.

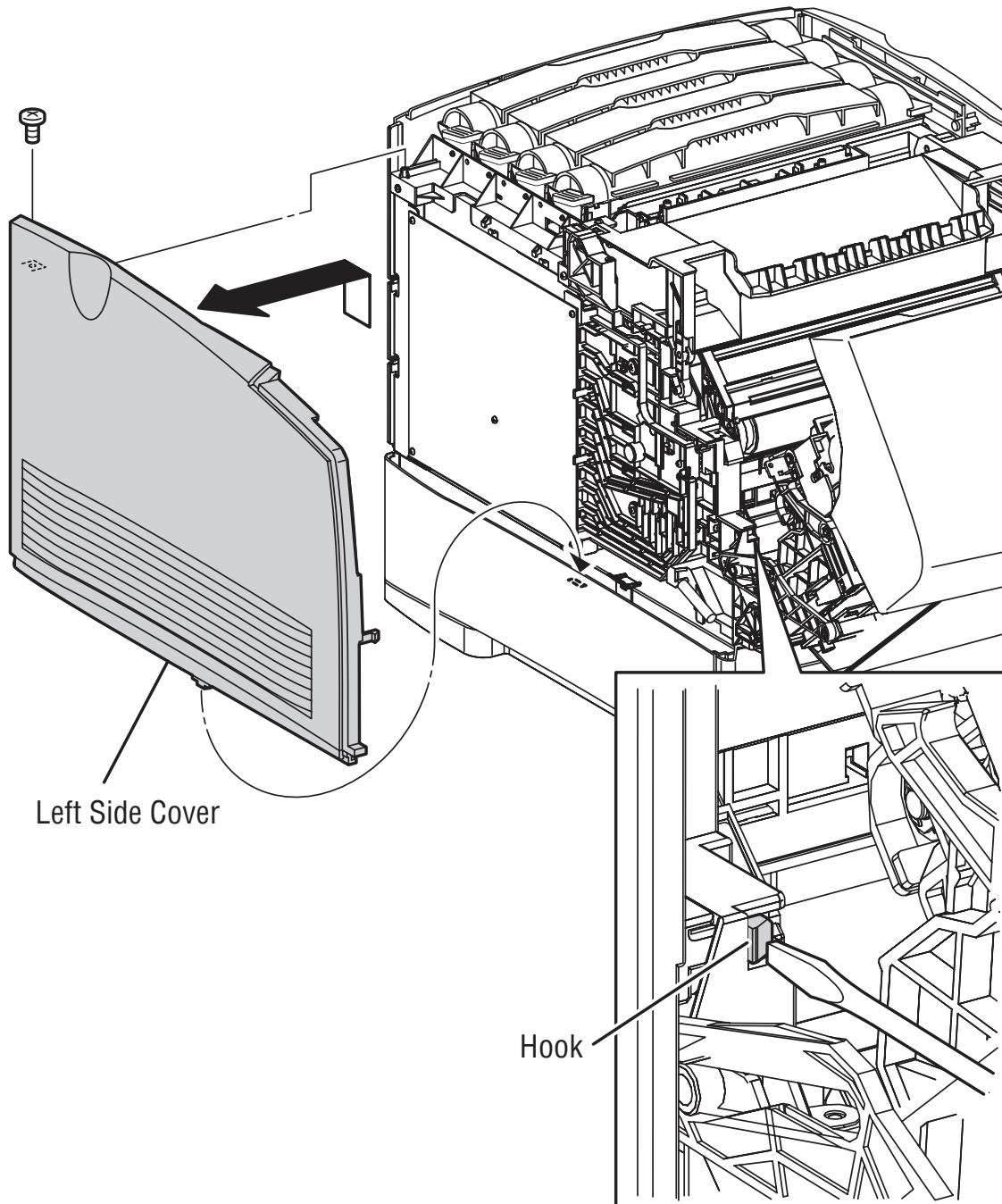

s6300-136

Door C (PL1.1.8)

1. Remove the Top Main Cover (page 8-8).
2. Remove the Right Side Cover (page 8-12).
3. Remove the Left Side Cover (page 8-13).
4. Open Door A.
5. Open Door C.
6. Pull out the left and right Studs that secure Door C.
7. Spread the bosses on the Developer Frame Assembly Guides that fit in the left and right notches of Door C and remove the door.

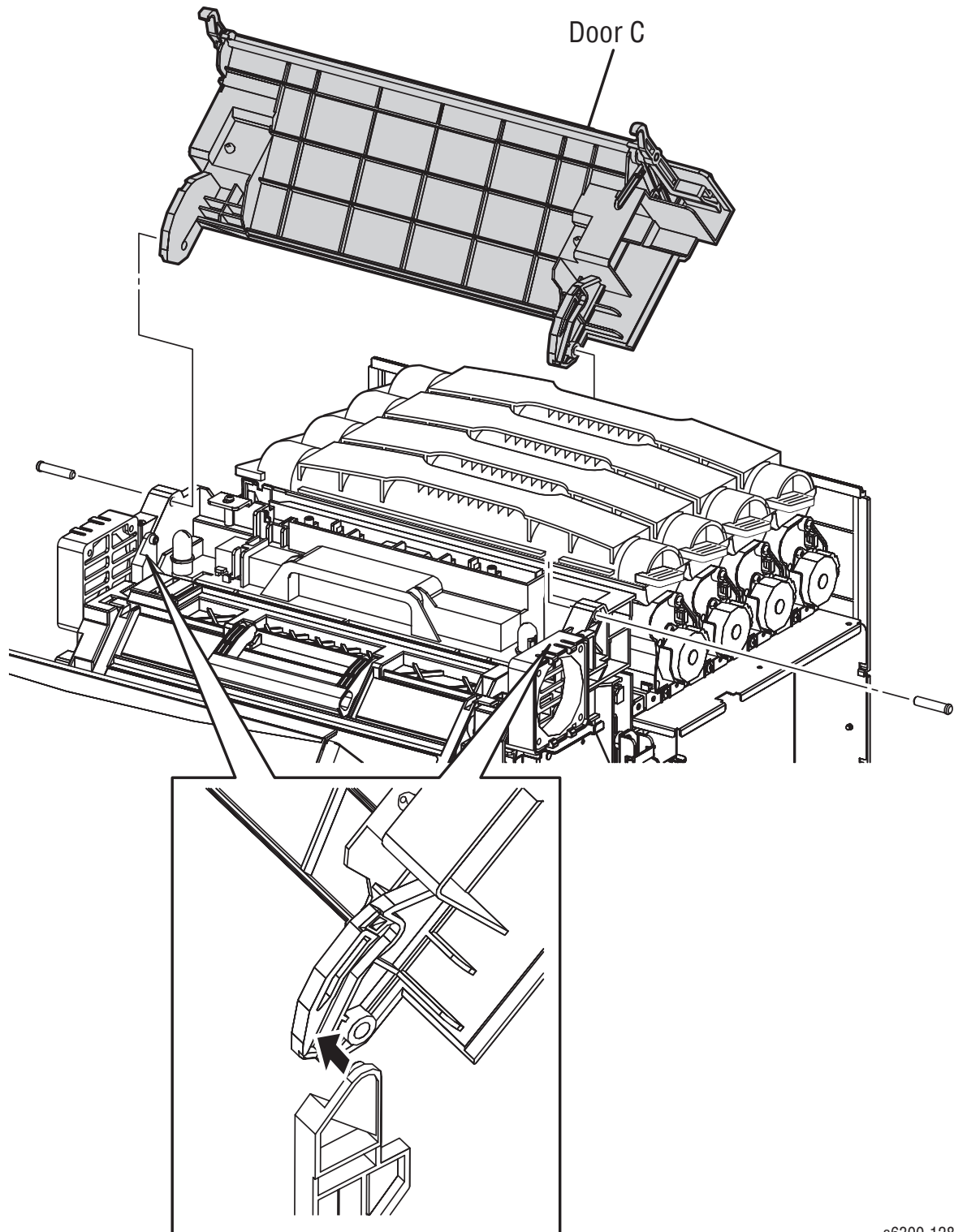

s6300-128

Replacement Note

Before reinserting the Studs, verify that the shoulders on the end of the pins face out and the Developer Frame Assembly Guide bosses are in the notches provided in Door C.

Rear Cover (PL1.1.17)

The Rear Fan is attached to the Rear Cover. When removing the Rear Cover, use care not to damage the Rear Fan harness.

1. Remove the Top Main Cover (page 8-8).
2. Remove the Right Side Cover (page 8-12).
3. Remove the Left Side Cover (page 8-13).
4. Unplug the Rear Fan connector (P/J166) from the LVPS.
5. Release the 3 harness clamps to remove the Rear Fan harness .
6. Lift the Rear Cover slightly to release the tabs from the frame and remove the Rear Cover.

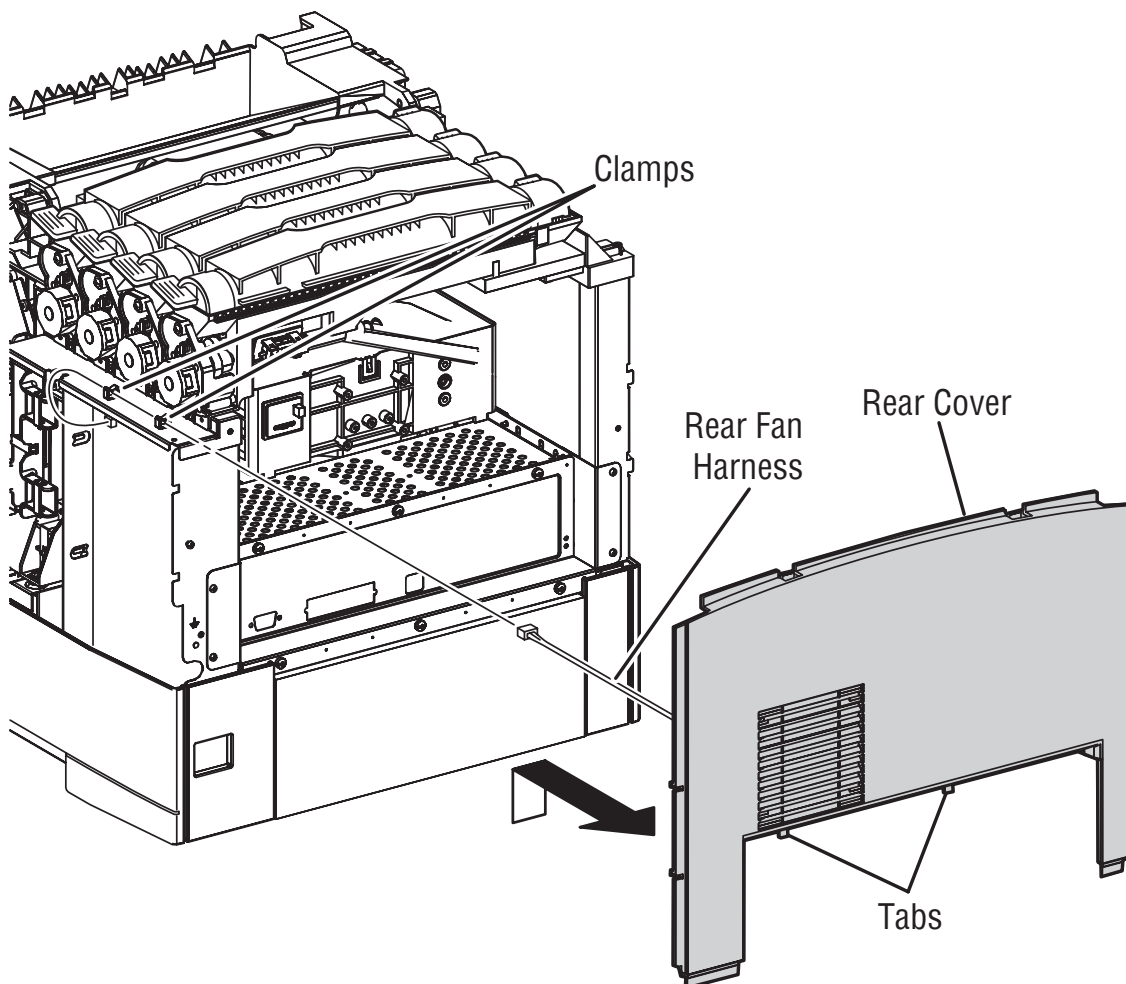

s6300-129

Right Front Cover (PL1.1.22)

1. Open Door A.
2. Remove the screw (self-tapping, plastic 10 mm) that secures the Right Front Cover.
3. Open Door A fully, and with Door B partially opened, release the 2 hooks to remove the Right Front Cover.

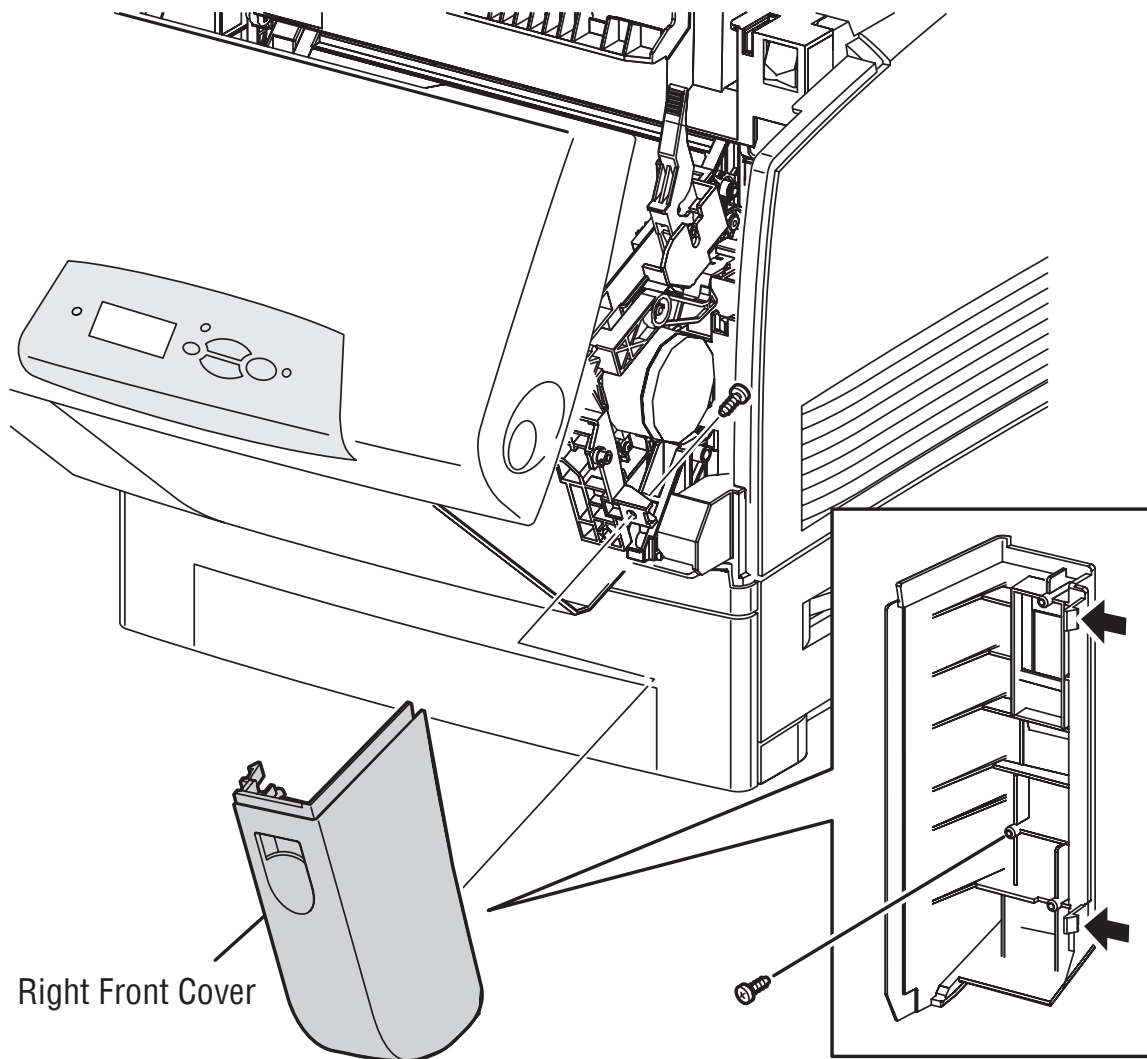

Left Front Cover (PL1.1.28)

1. Open Door B.
2. Release the 3 hooks that secure the Left Front Cover and remove.

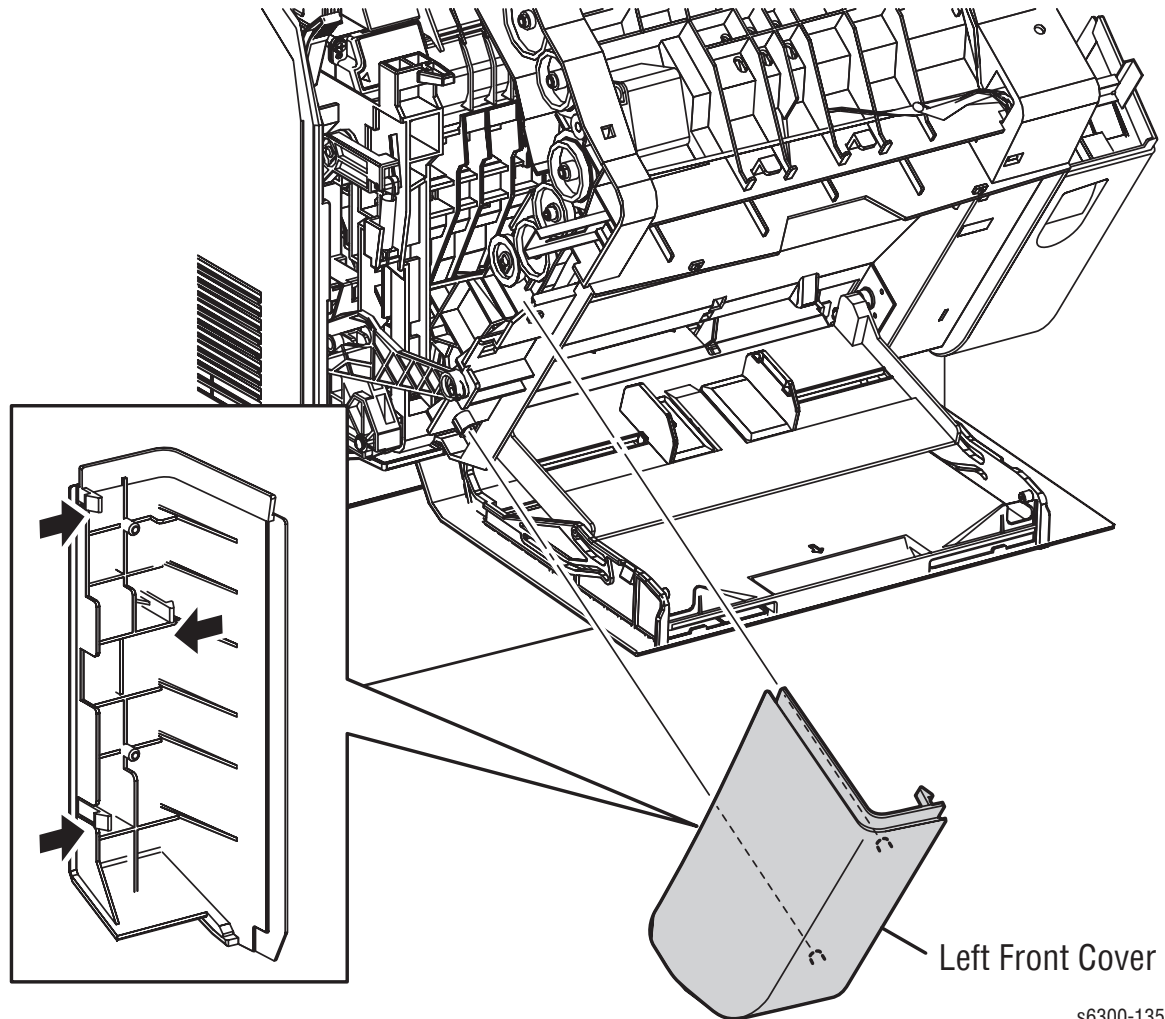

s6300-135

Front Feeder Frame Cover (PL3.1.1)

1. Remove Tray 2.
2. Release the four hooks that secure the Front Feeder Frame Cover to the printer.

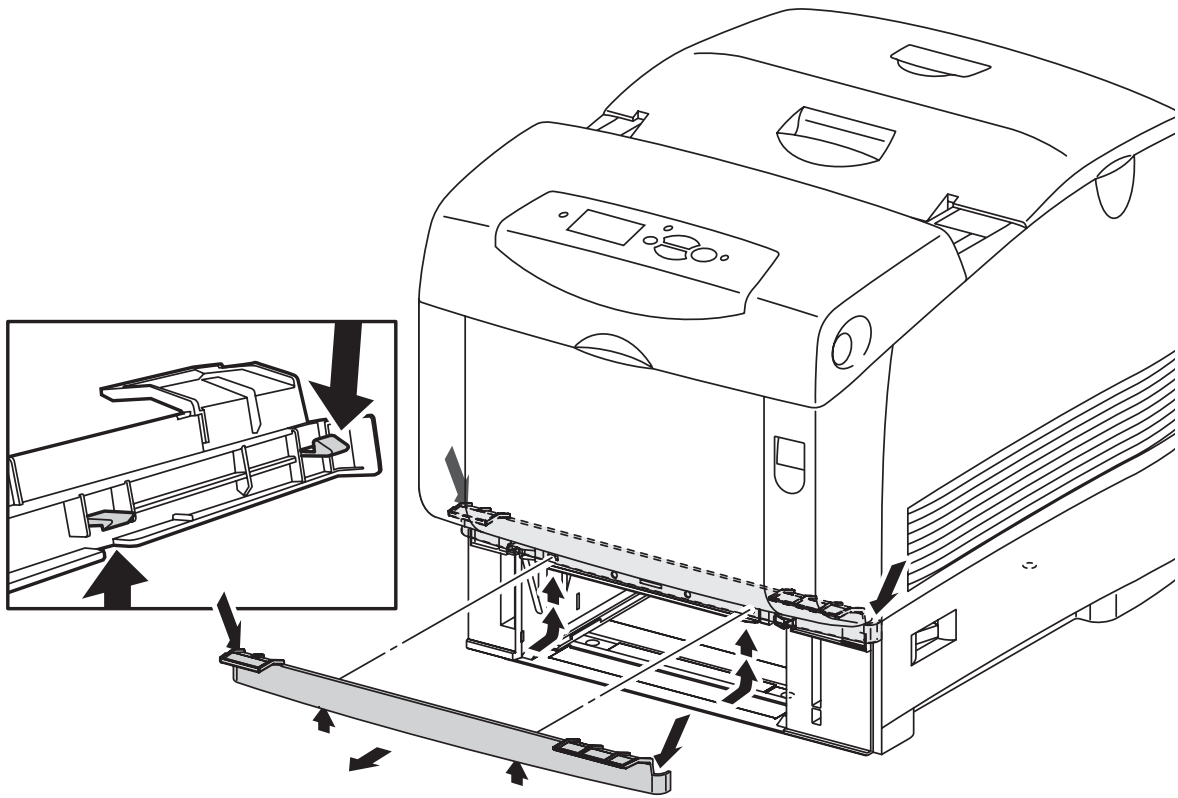

s6300-351

Universal Tray

Retard Assembly (PL2.1.12)

1. Remove the tray.
2. Release the 2 tabs at the left and right of the Turn Chute by pushing inward and open the chute.
3. Rotate the Retard Holder 90 degrees.
4. Slide the Retard Assembly to the left to remove it from the 2 bosses, and then lift upward.

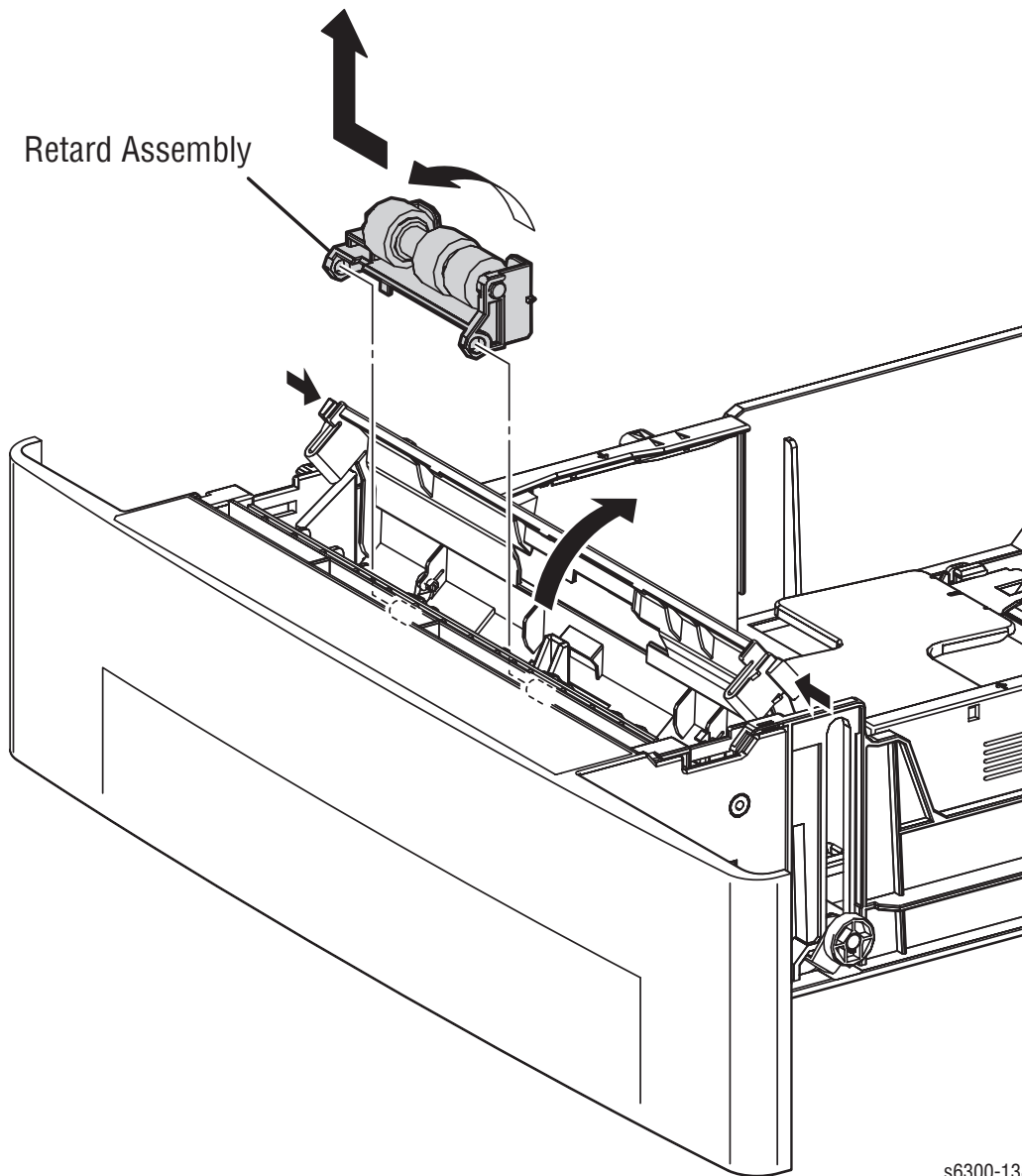

s6300-138

Paper Feeder

Feeder Chute (PL3.1.2)

1. Remove Tray 2.
2. Push in and then down at the two recesses located at the left and right of the Feeder Chute and swing the Feeder Chute downward.
3. Pull the Feeder Chute forward past the detent, and then down to release the bosses located at each end.

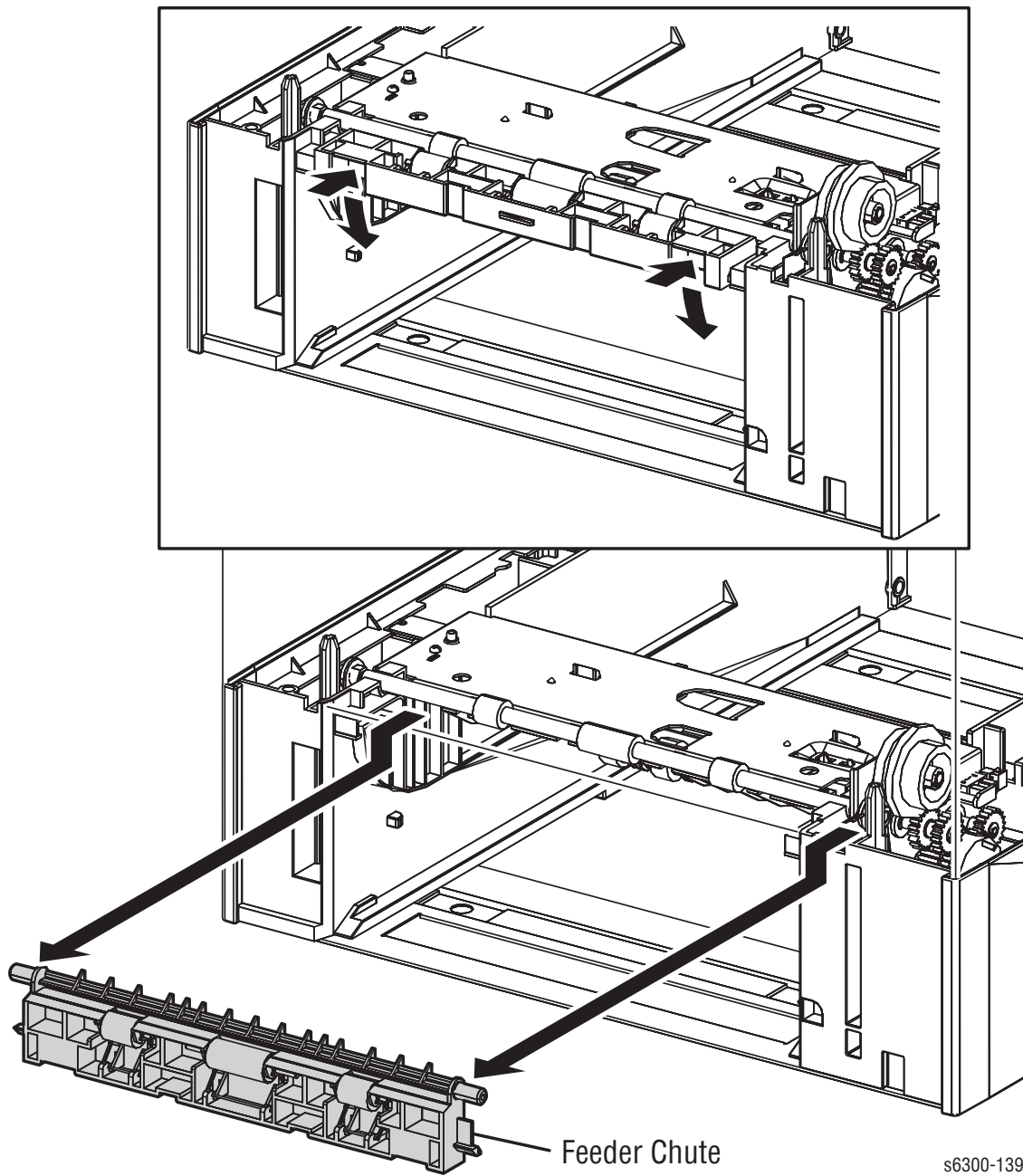

Replacement Note

Insert the left side boss of the Feeder Chute first.

Tray Rear Cover (PL3.1.3)

1. Pivot and lift the top of the Tray Rear Cover toward you to remove it from the printer.

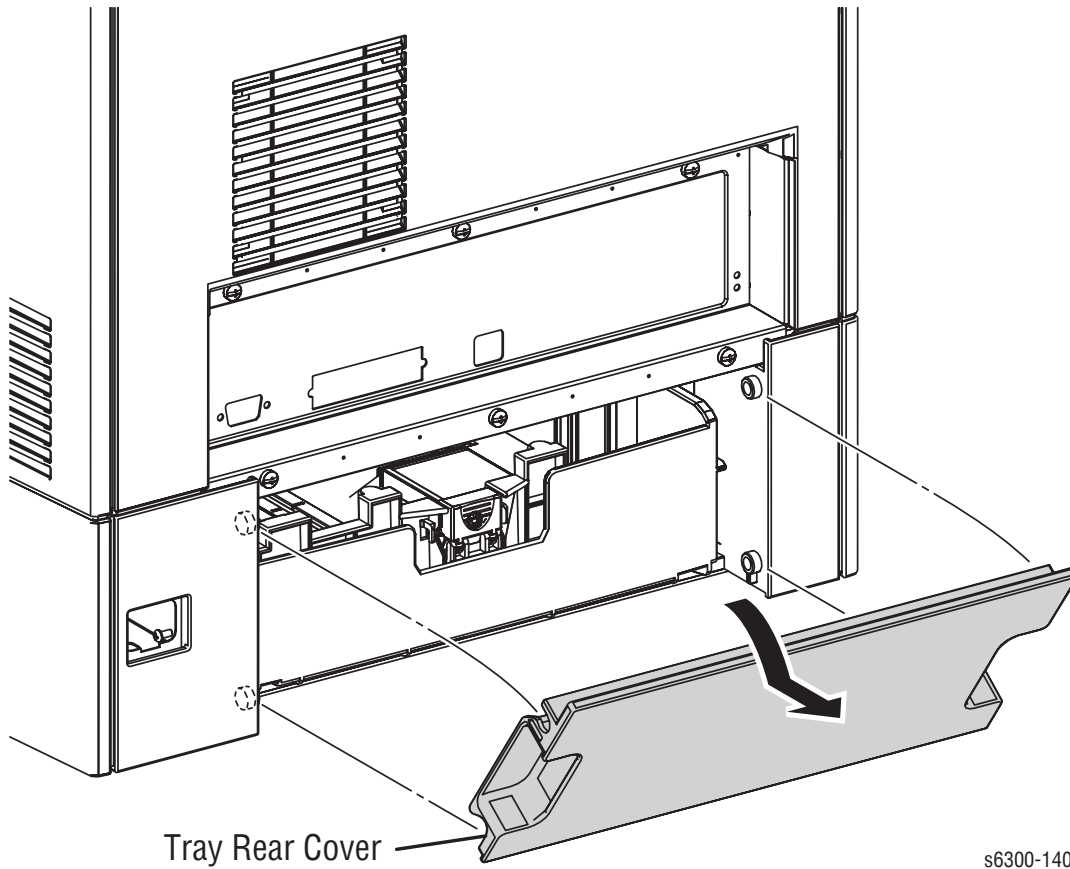

Printer Chassis

Removal of the printer chassis is required to service the following components:

- Tray 2 Paper Size Switch
- Option Feeder Harness
- Tray 2 Paper Pick Assembly
- Tray 2 No Paper Sensor and Actuator

Caution

Two people are required to separate the printer chassis from the Tray 2 Feeder.

1. Remove Tray 2.
2. Remove the Top Main Cover (page 8-8).
3. Remove the Right Side Cover (page 8-12).
4. Remove the Left Side Cover (page 8-13).
5. Remove the Rear Cover (page 8-16).
6. Remove the Feeder Chute (page 8-21).
7. Remove the Front Feeder Frame Cover (page 8-19)
8. Perform steps 1 and 2 of the I/P Board removal procedure (page 8-98).
9. Remove the HVPS (page 8-109).
10. Remove the Temperature/Humidity Sensor Bracket (page 8-108).
11. Remove the 1 screw (silver, 6 mm) that fixes the Power Switch Link Support Bracket and remove the bracket.
12. Unplug connectors (P/J161, 162, 163, 164, and 165) from the LVPS.
13. Unplug connectors (P/J17 and P/J47) from the Engine Control Board.
14. Remove the 4 screws (metal, 6 mm) that secure the printer frame to the LVPS Box. Three of these screws are located on the rear side of the LVPS Box. The fourth is located in a cutout at the front, center of the LVPS circuit board.
15. Remove the 5 screws (self-tapping, plastic 10 mm) located around the perimeter of the chassis.
16. Remove 3 long screws that secure the chassis at the rear left corner, front left corner near the base of Door A, and the front right corner.
17. Remove the Registration Roller Assembly (page 8-38).
18. Remove the Registration Chute (page 8-34).
19. Loosen the harnesses of (P/J17) and (P/J47) from the slit in the bottom plate.
20. Remove the screw (metal, 6 mm) that secures the printer frame to the Tray 2 Paper Pick Assembly.
21. Lift the chassis by the frame and separate it from Tray 2.

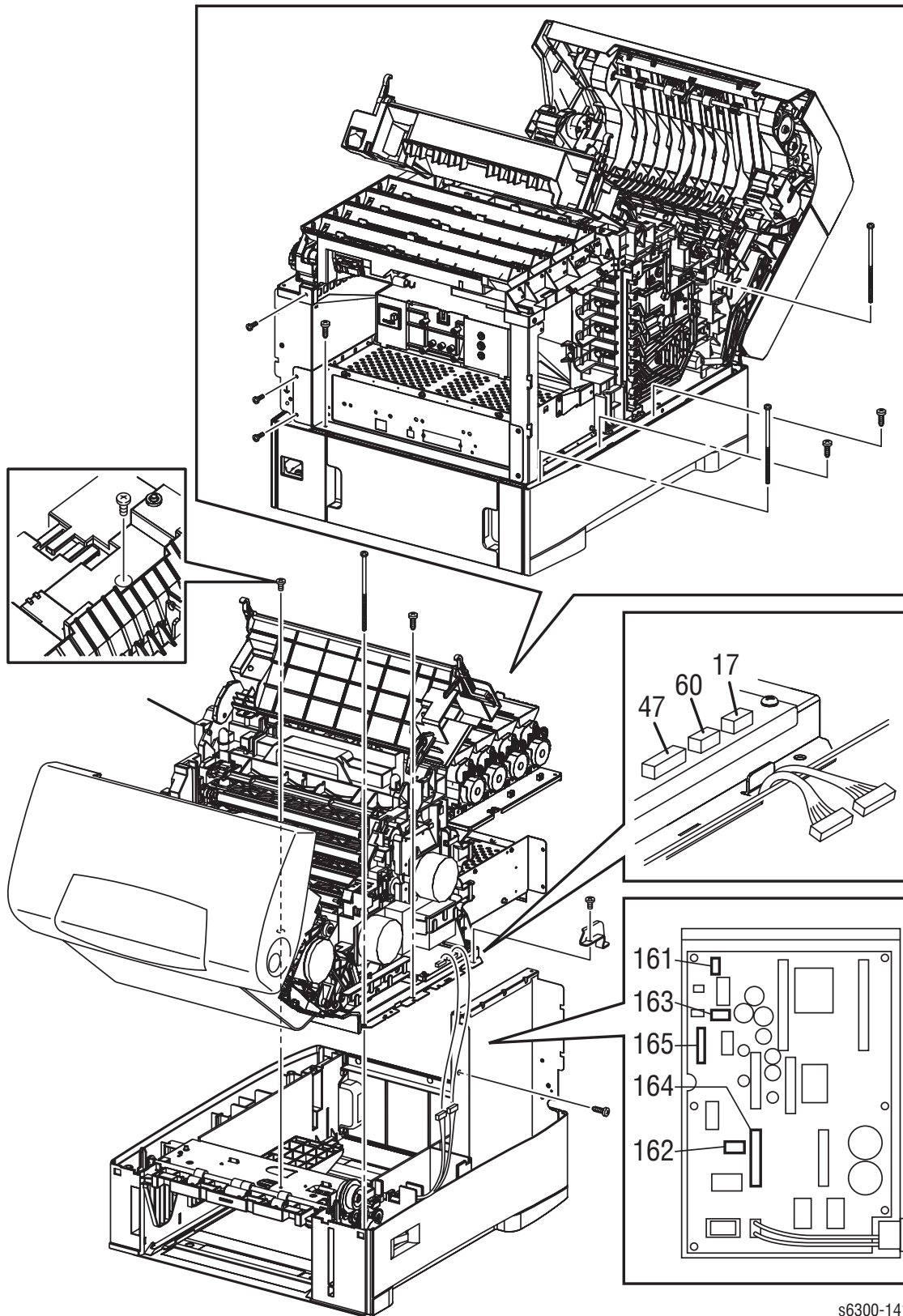

s6300-141

Replacement Note

Verify that the Power Switch linkage is in place prior to securing the support.

Paper Size Switch Assembly (PL3.2.24)

1. Remove the Printer Chassis (page 8-23).
2. Remove the screw (self-tapping, plastic 10 mm) that secures the Paper Size Switch to the Right Feeder.
3. Release the Latch and lift the Paper Size Switch from the feeder.
4. Unplug connector (P/J471) from the Paper Size Switch.

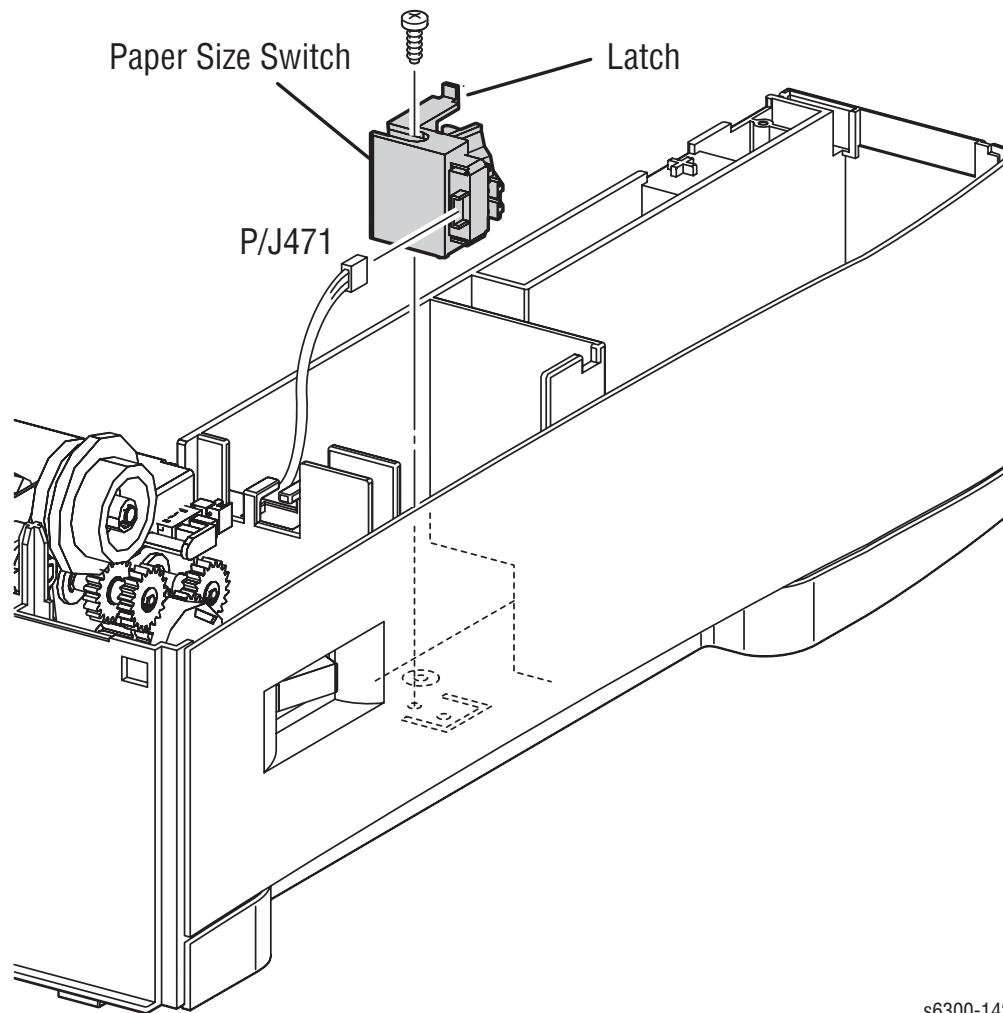

s6300-142

Replacement Note

Hook the Paper Size Switch latch to the feeder housing before locating and securing the screw.

Option Feeder Harness (PL3.2.11)

The option connector located at the end of the Option Feeder Harness may be disconnected from the replacement harness and used to repair a damaged connector. The connector's construction allows for replacement without removal of the printer chassis. Remove the Right Cover, Disconnect P/J17 at the Engine Control Board to provide slack in the harness, then move the printer so the connector overhangs the edge of the supporting surface and squeeze the hooks to release the damaged connector from the frame.

When replacing the entire harness, follow this procedure:

1. Remove the Printer Chassis (page 8-23).
2. Remove the Option Feeder harness from the harness guide of the Right Feeder.
3. Release the 2 hooks that secure the Option Feeder harness connector to the Right Feeder.
4. Remove the Option Feeder harness from the bottom of the Right Feeder.

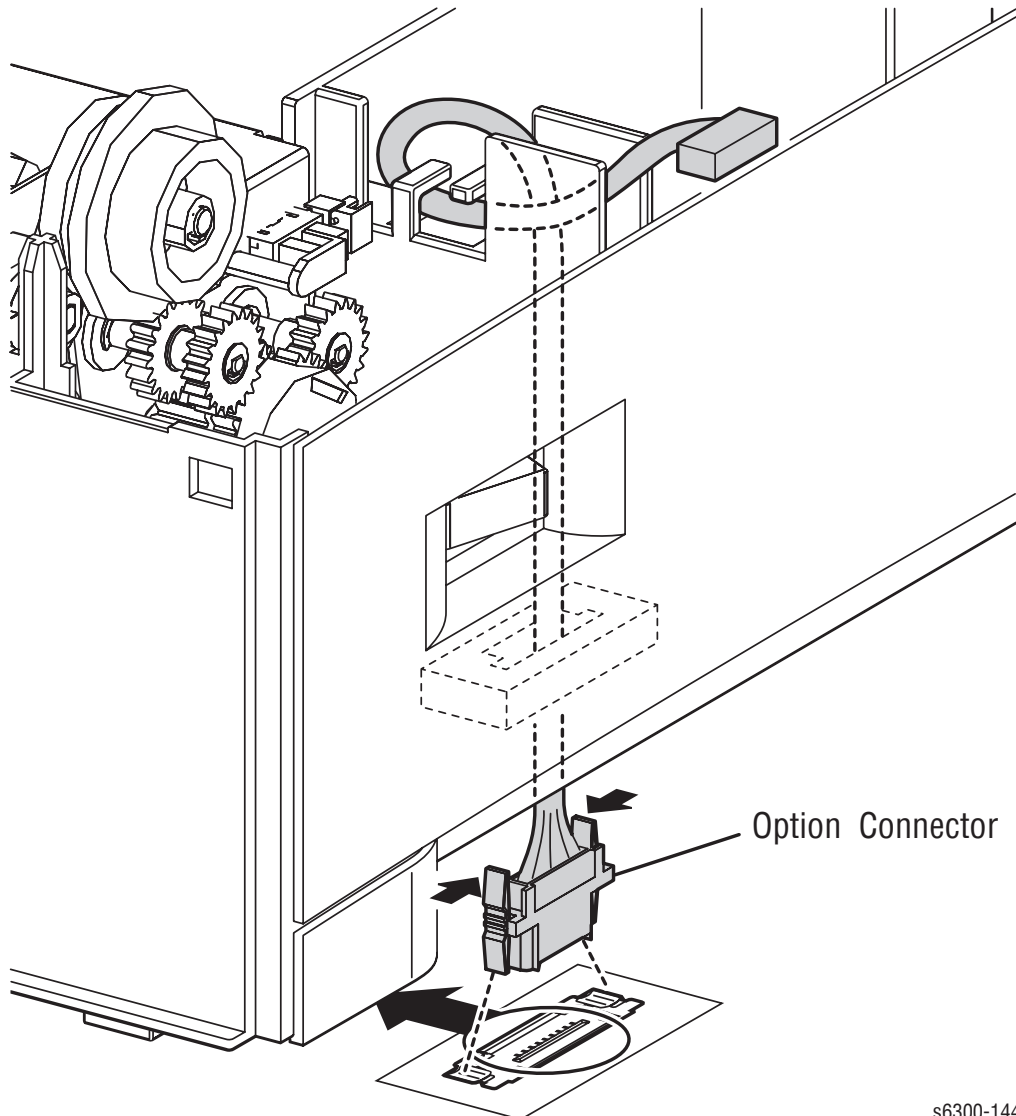

s6300-144

Paper Pick Assembly (PL3.3.1)

1. Remove the Printer Chassis (page 8-23).
2. Remove the plug (P471) from the Paper Size Switch.
3. Loosen the harness to the Paper Pick Assembly from the Feeder harness guide.
4. Remove the 2 screws (self-tapping, plastic 10 mm) that secure the Paper Pick Assembly to the Feeder and remove.

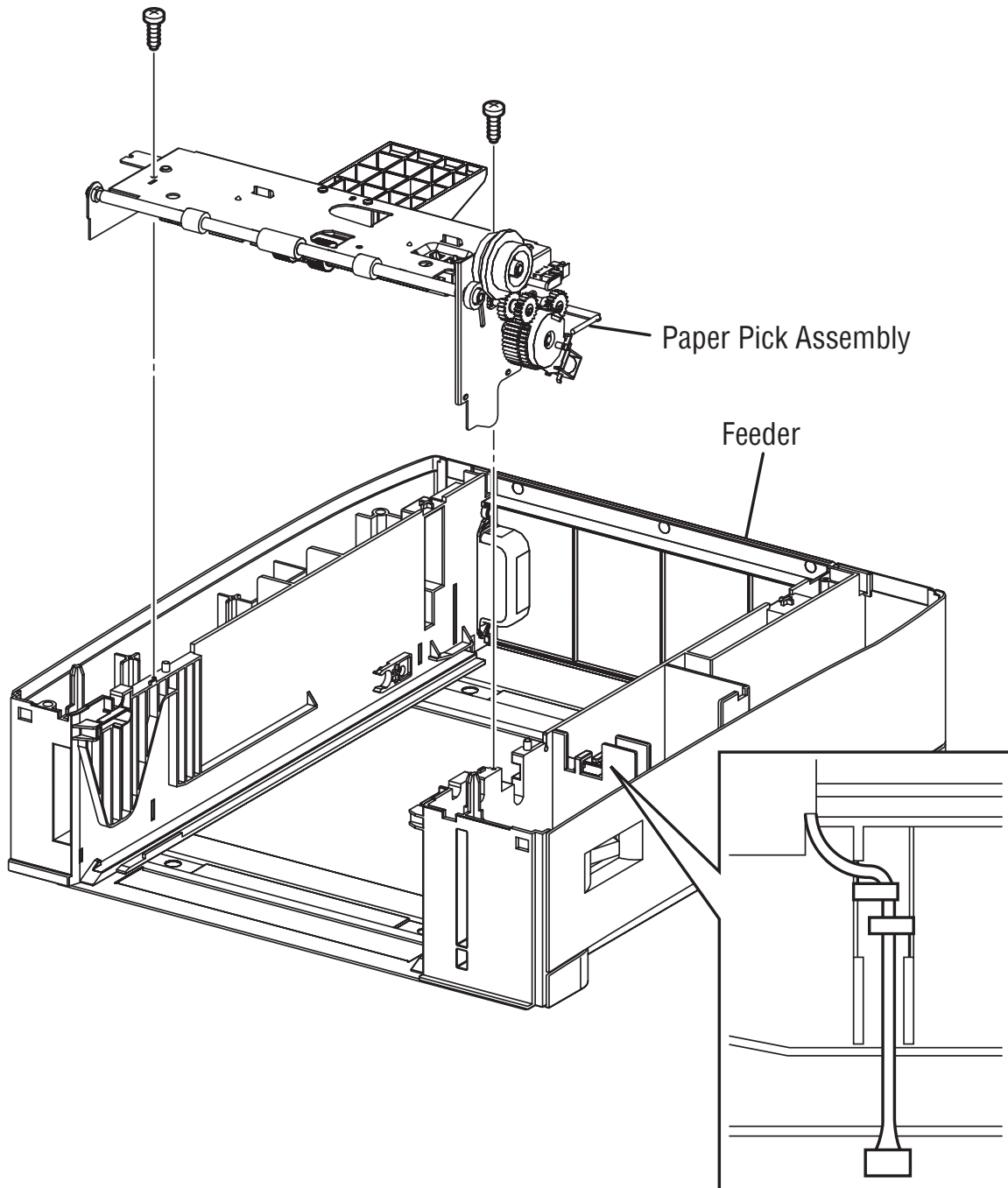

s6300-145

No Paper Sensor (PL3.3.7)

1. Remove the Printer Chassis (page 8-23).
2. Remove the Paper Pick Assembly (page 8-27).
3. Unplug connector (P/J472) from the No Paper Sensor.
4. Release the 3 hooks on the sensor to release it from the Paper Pick Assembly.

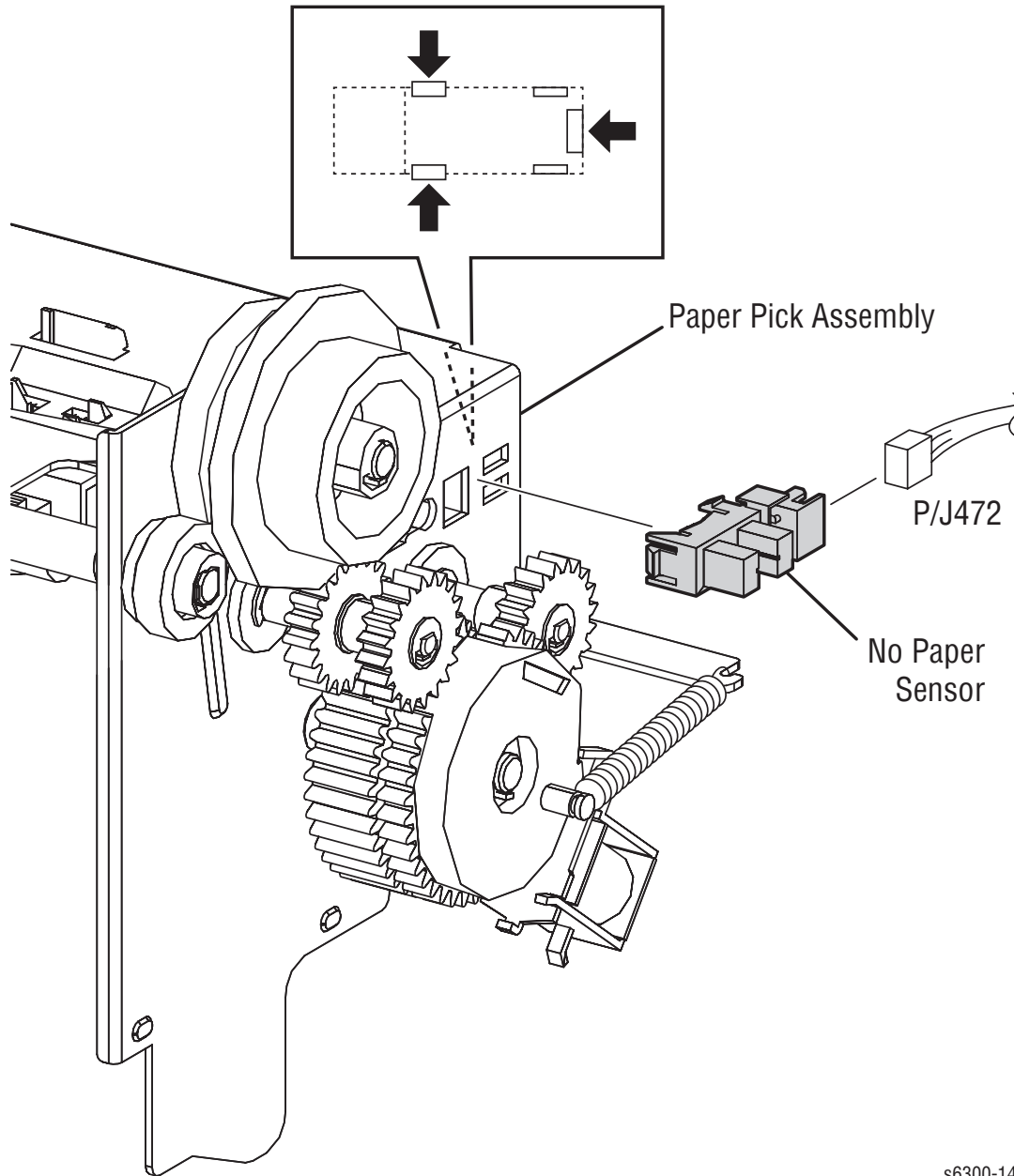

s6300-147

Low Paper Sensor (PL3.3.7)

Remove the Low Paper Sensor from the Paper Pick Assembly by reaching in from the front of the printer and squeezing the side hooks of the sensor.

1. Remove Tray 2.
2. Remove the Feeder Chute (page 8-21).
3. Remove the Upper Chute (page 8-30).
4. Release the 3 hooks and disconnect (P/J473) from the Low Paper Sensor.

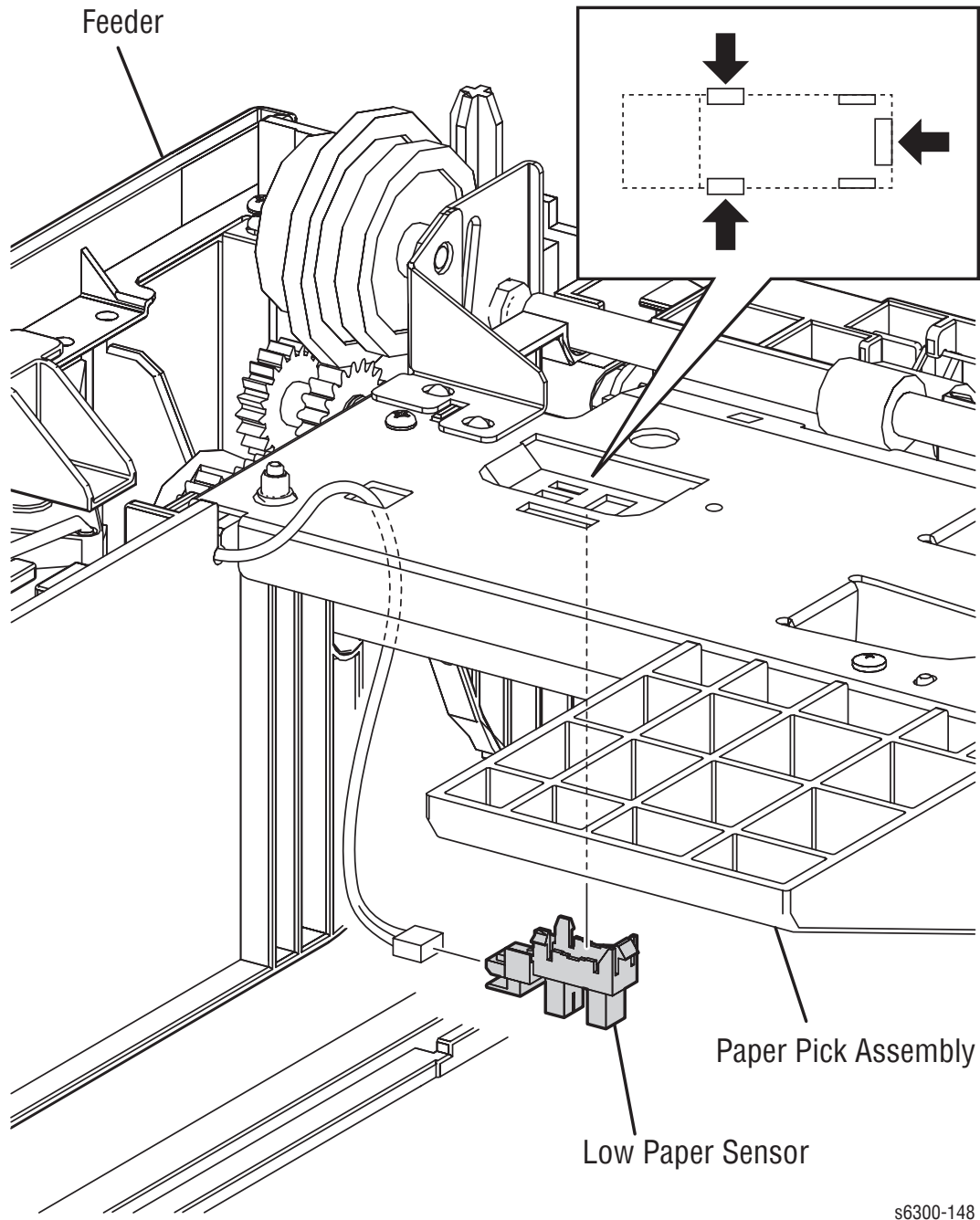

s6300-148

Replacement Note

Insert the sensor end hook first, and then lock the side hooks.

Upper Chute (PL3.3.15)

1. Remove the tray.
2. Release the 2 hooks that secure the Upper Chute to the Paper Pick Assembly. Slide the Upper Chute first to the back, release the 4 hooks, and then remove the Upper Chute downward.

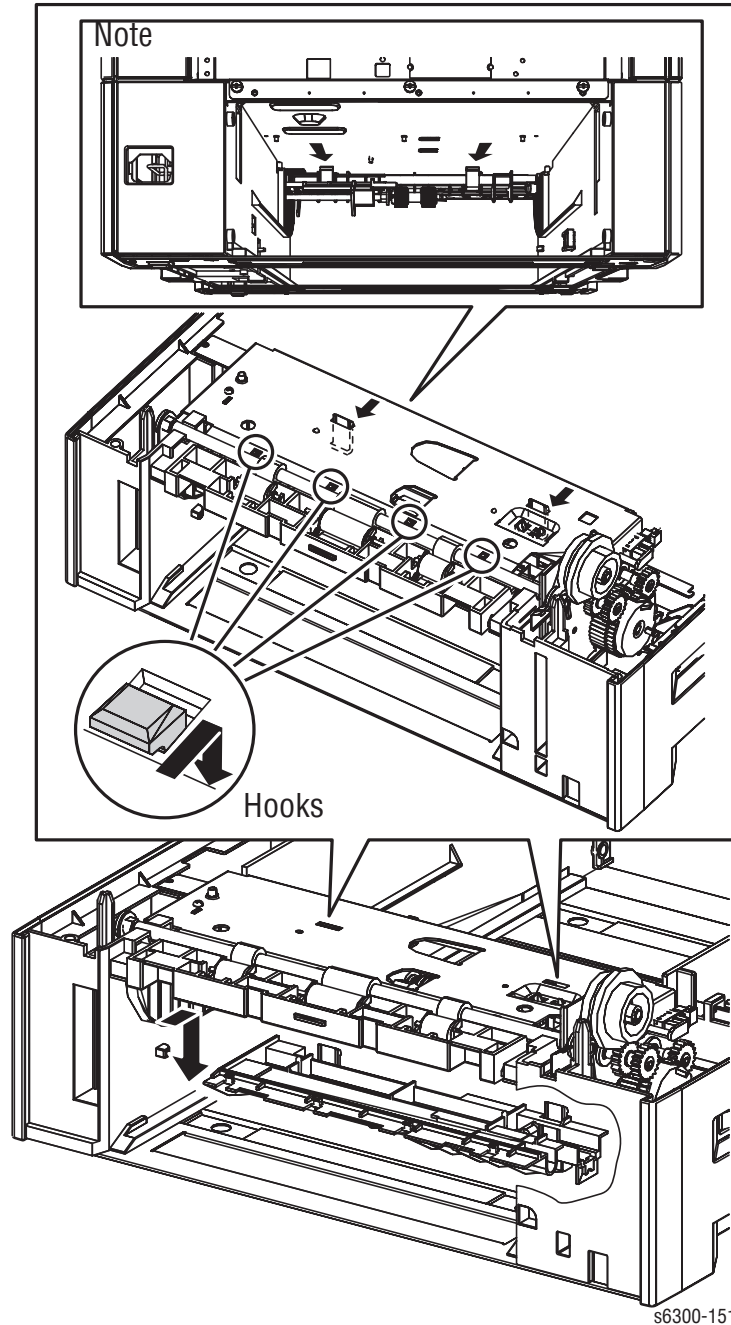

Low Paper Sensor Actuator (PL3.3.14)

1. Remove the Upper Chute (page 8-30).
2. Release the hook of the Upper Chute that secures the Low Paper Sensor Actuator, and move the actuator in the direction of the arrow (2) to remove.

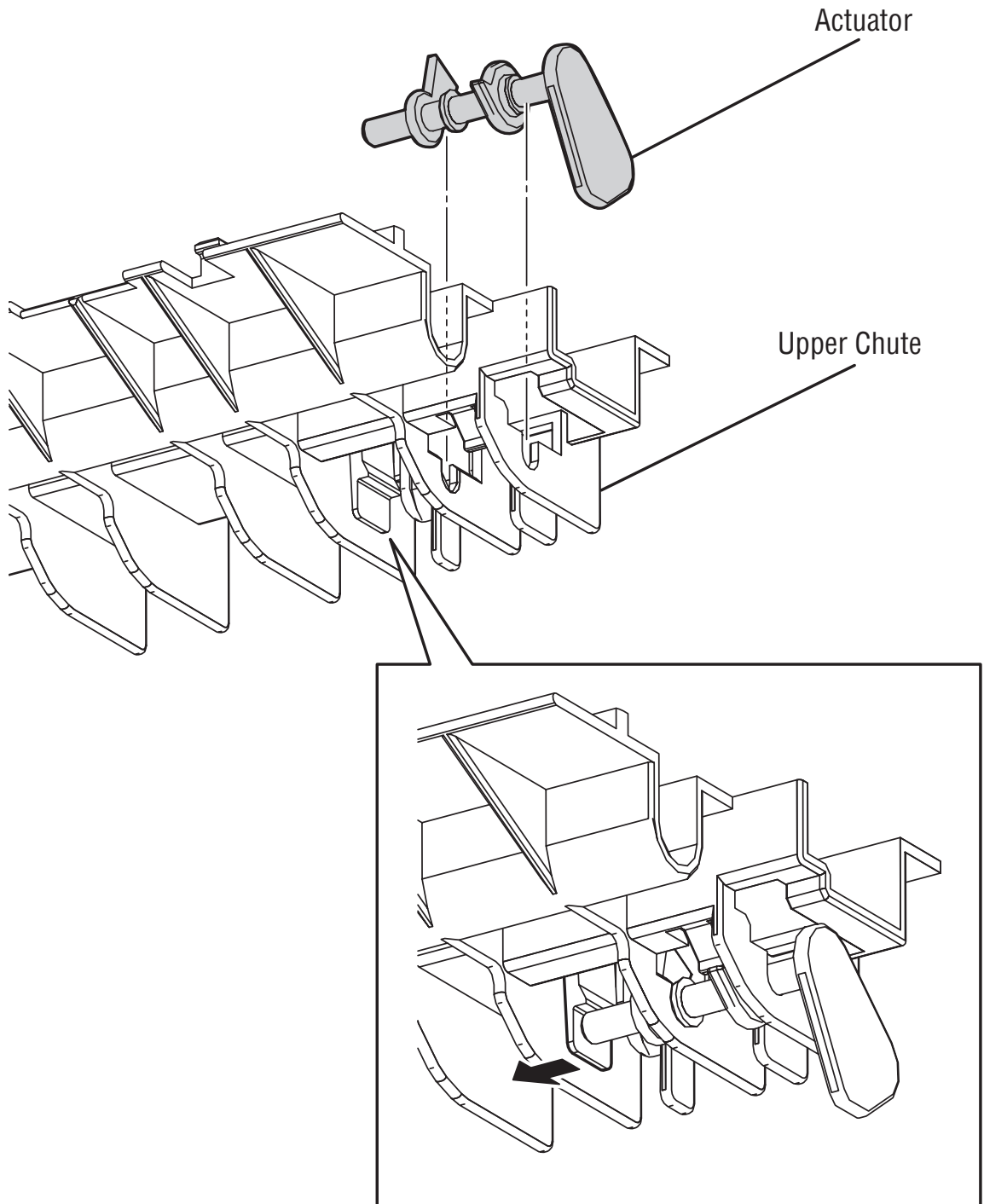

s6300-150

Replacement Note

While holding the Upper Chute, insert the flag downward from the top.

Feed Roller (PL3.3.18)

1. Remove the tray.
2. Release the locks that secure the Feed Rollers to the Feed and Nudger Shafts, and then remove the rollers.

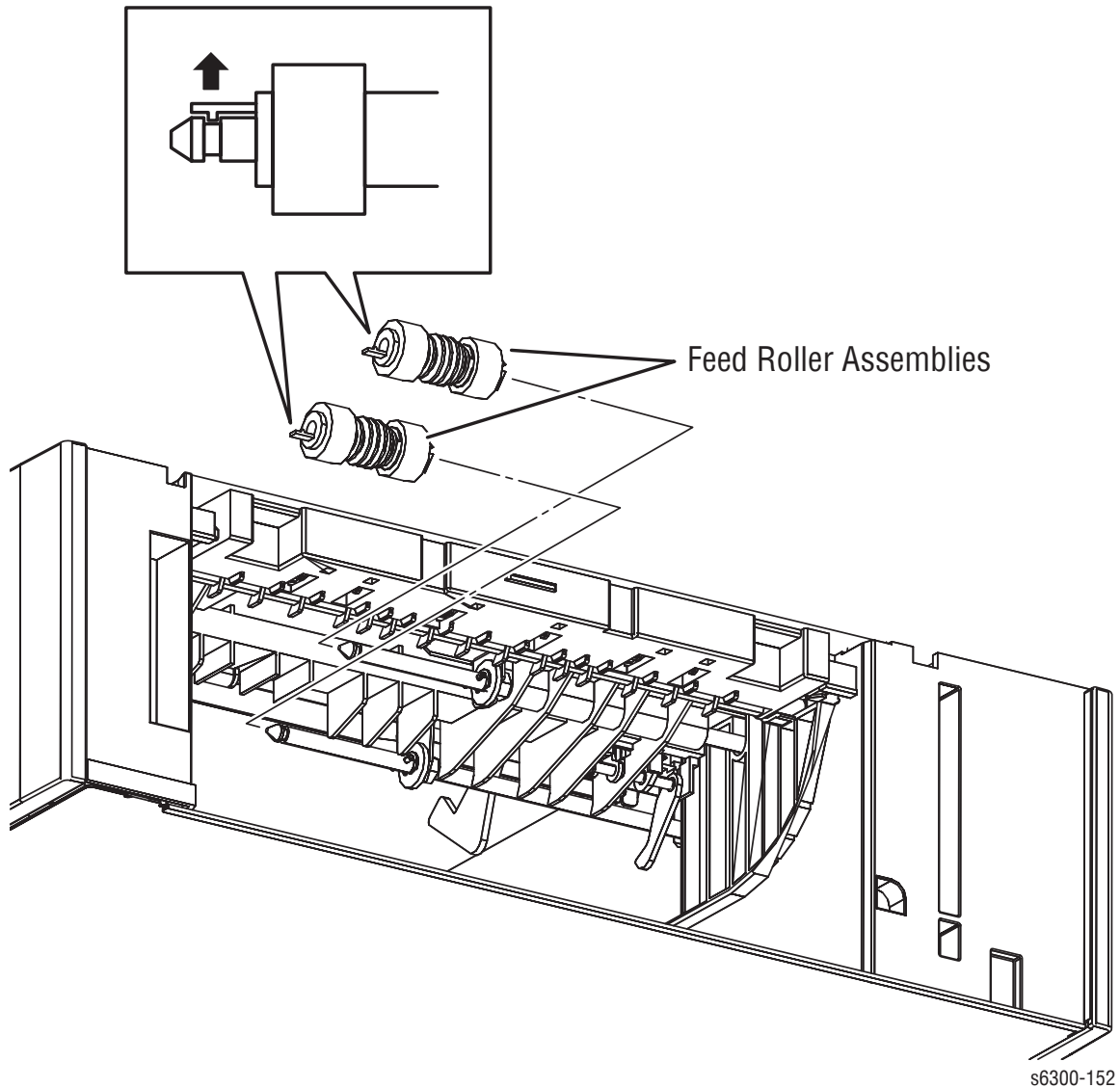

No Paper Sensor Actuator (PL3.3.20)

1. Remove the Printer Chassis (page 8-23).
2. Remove the Feeder Chute (page 8-21).
3. Remove the Paper Pick Assembly (page 8-27).
4. Turn the Paper Pick Assembly over.
5. Release the hook that secures the No Paper Sensor Actuator to the Paper Pick Assembly.
6. Pull the actuator out slightly, and then shift the thin section of the shaft from the hole to the slot side. (No Paper Sensor removed for simplification.)
7. Remove the No Paper Sensor Actuator shaft out of the hole in the Paper Pick Assembly while moving the hook side of the actuator forward.

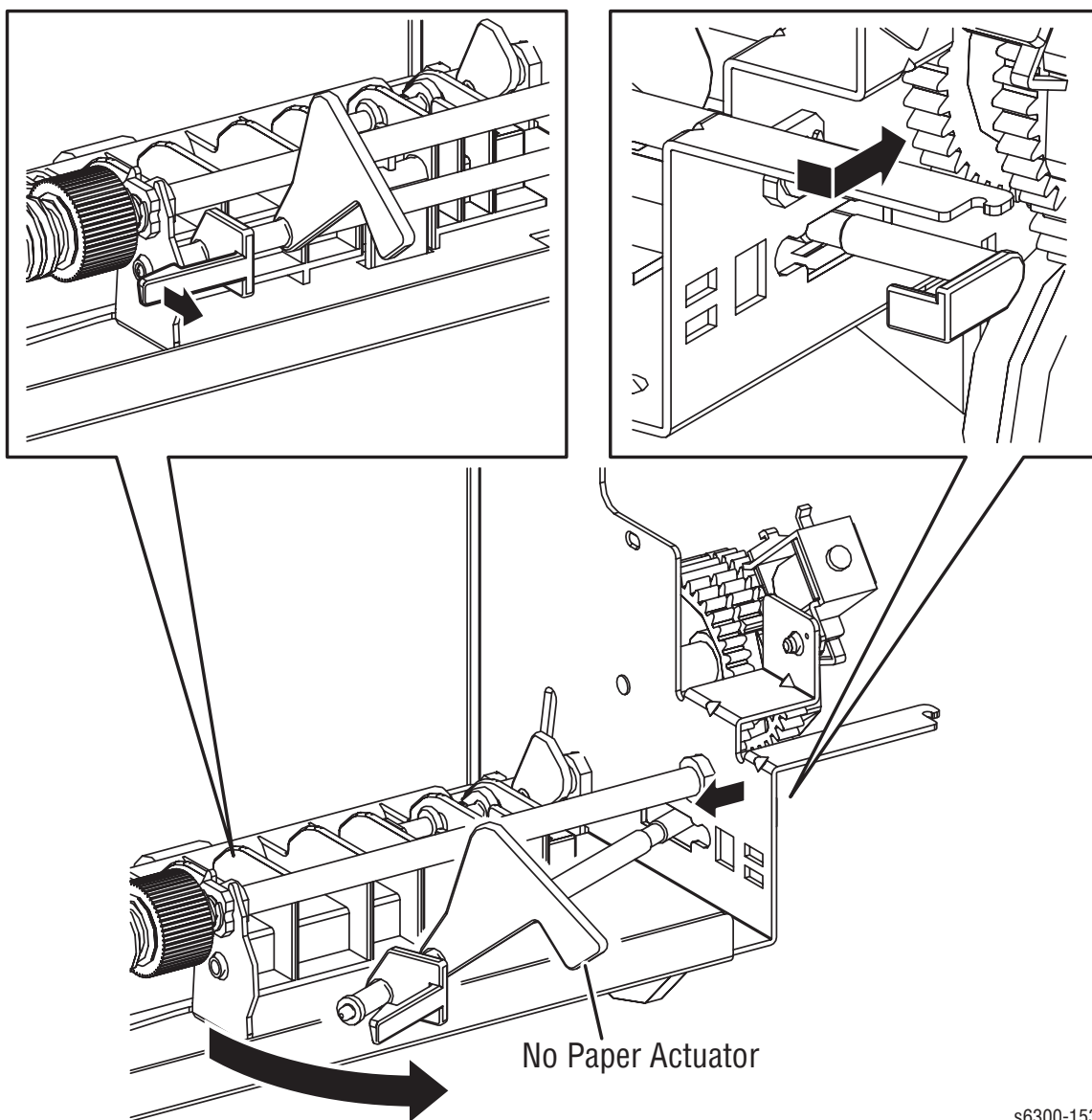

s6300-153

Retard and Registration

Caution

After removal of the Imaging Unit, protect the Developer Assemblies by covering the rollers with a sheet of paper or other similar technique.

Registration Chute (PL4.1.5)

1. Open Door A.
2. Remove the Imaging Unit.
3. Remove the Registration Roller Assembly (page 8-38).
4. Release the sensor wiring from the bottom harness guides.
5. Remove the connector (P/J181) of Registration Sensor on the Registration Chute.
6. Lift the rear part of Registration Chute and pull it out rearward to remove.

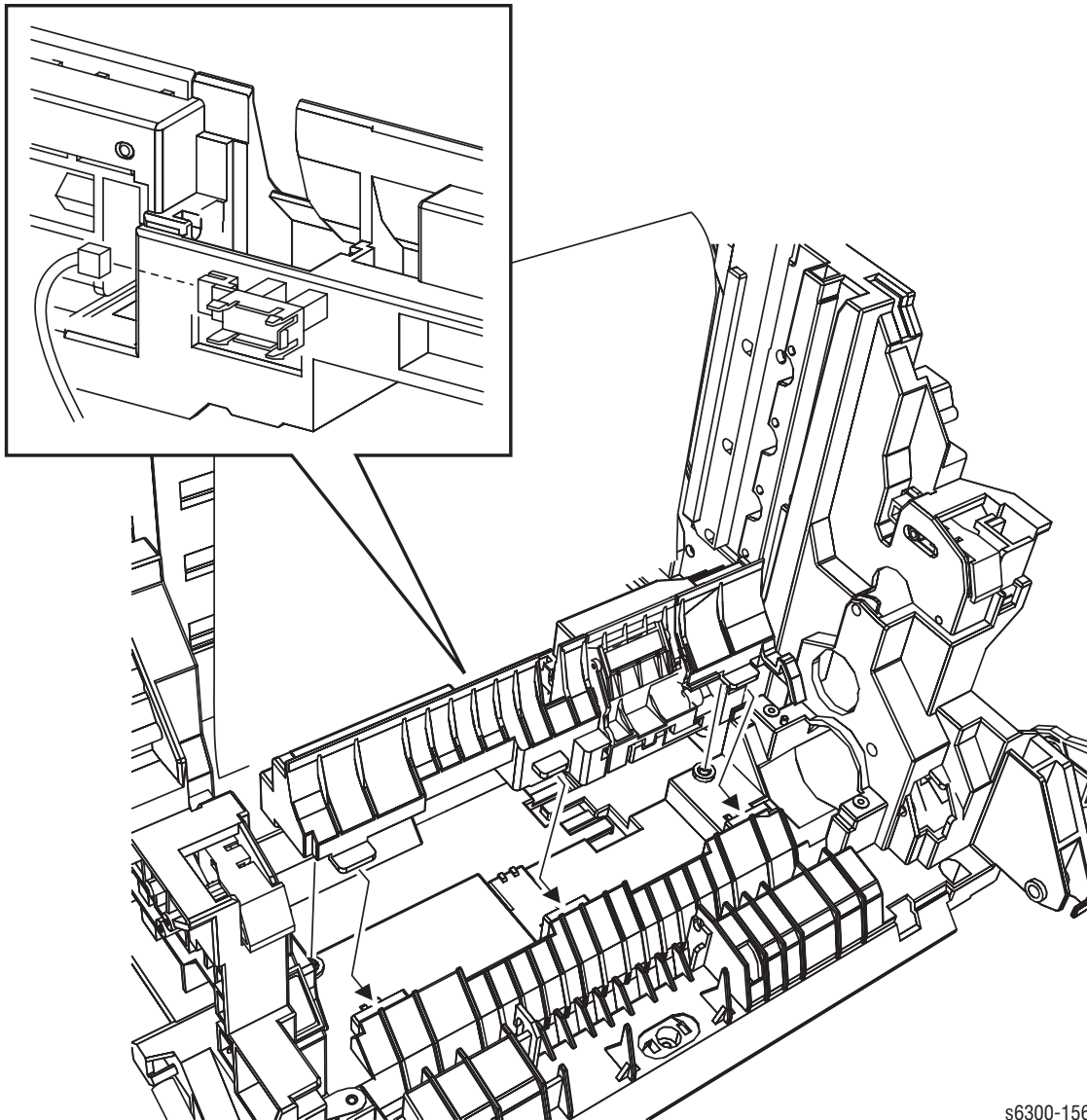

s6300-156

Registration Sensor Actuator (PL4.1.1)

Caution

After removal of the Imaging Unit, protect the Developer Assemblies by covering the rollers with a sheet of paper or other similar technique.

1. Open Door A.
2. Remove the Imaging Unit.
3. Remove the Registration Roller Assembly (page 8-38).
4. Remove the Registration Chute (page 8-34).
5. Move the actuator beyond the notch to near vertical, and then lift the left end of the actuator shaft and move the shaft right to remove it from the mounting hole.
6. Remove the actuator spring.

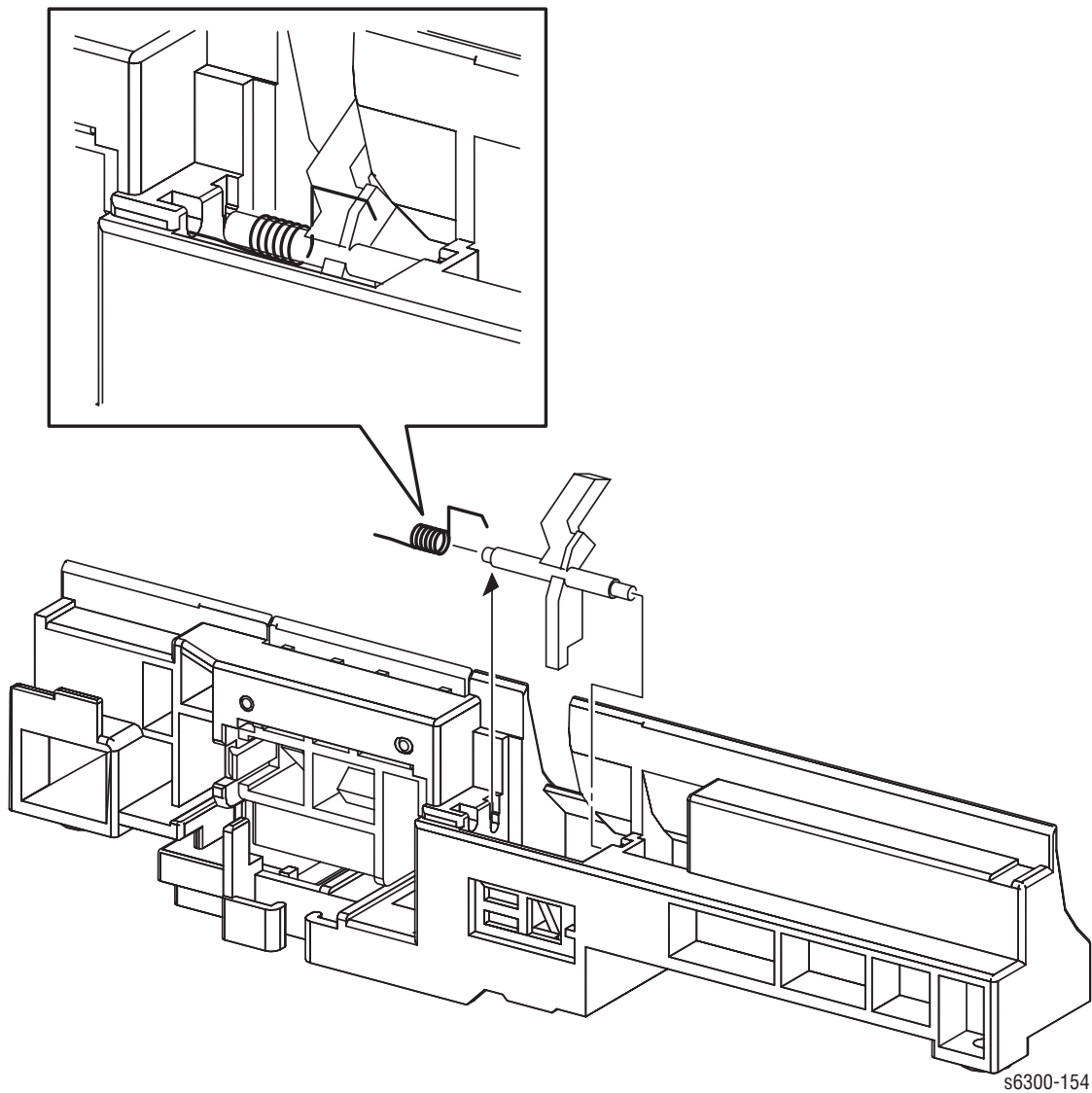

Registration Sensor (PL4.1.3)

Caution

After removal of the Imaging Unit, protect the Developer Assemblies by covering the rollers with a sheet of paper or other similar technique.

1. Open Door A.
2. Remove the Imaging Unit.
3. Remove the Registration Chute (page 8-38).
4. Remove the Registration Chute In (page 8-34).
5. Disconnect the connector (P/J181) from the Registration Sensor.
6. Release the 3 hooks that secure the Registration Sensor to the Registration Chute In and remove the sensor.

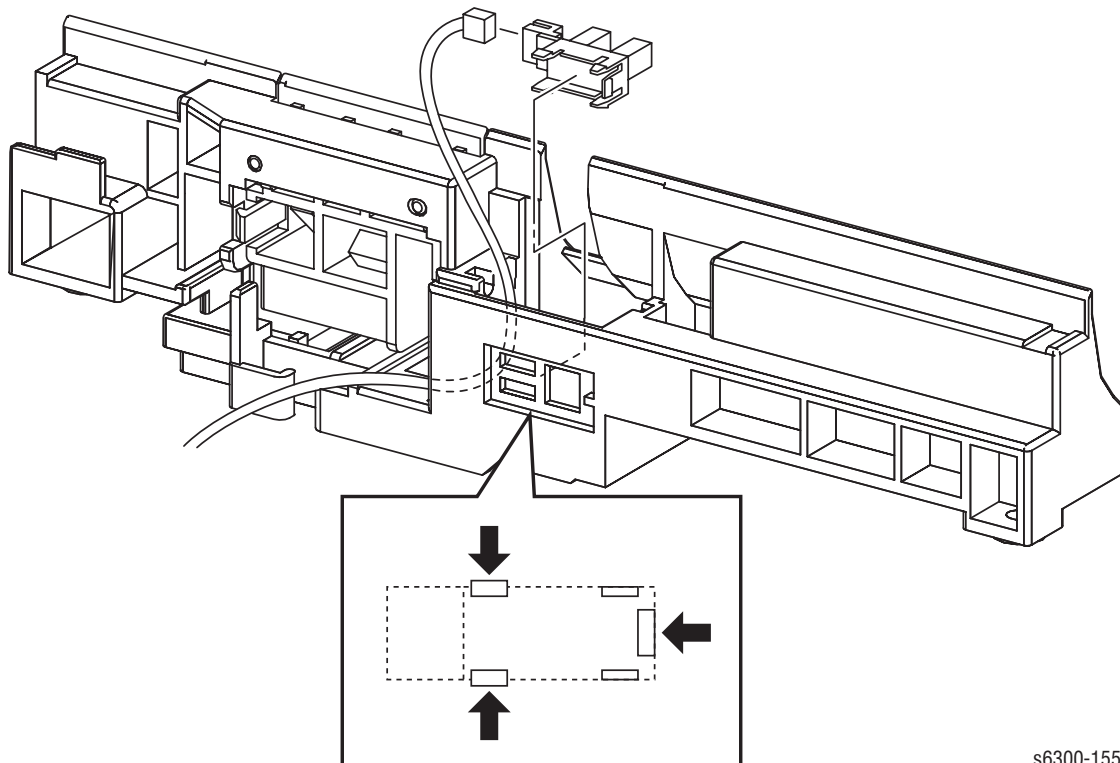

s6300-155

Retard Holder Assembly (PL4.1.16)

1. Open the Door A.
2. Remove the Transfer Roller.
3. Turn the Retard Holder Assembly upward.
4. Move the Retard Holder Assembly to the right to release the shaft and remove the Retard Holder Assembly.

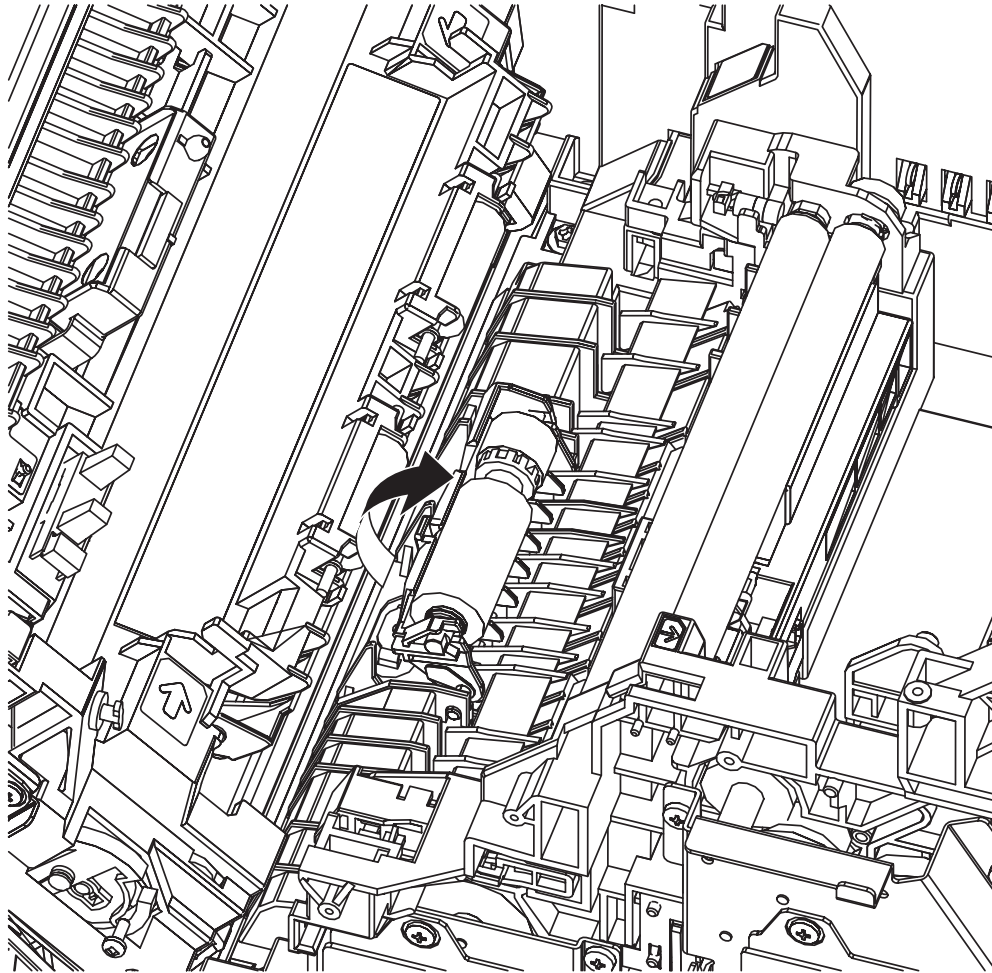

s6300-158

Registration Roller Assembly (PL4.2.1)

Caution

After removal of the Imaging Unit, protect the Developer Assemblies by covering the rollers with a sheet of paper or other similar technique.

1. Open Door A.
2. Remove the Imaging Unit.
3. Remove 4 screws (self-tapping, plastic 10 mm) that secure the Registration Roller Assembly.
4. Disconnect the two connectors connected to Registration Roller Assembly.
5. Move the Registration Roller Assembly to the left and lift it up to remove.

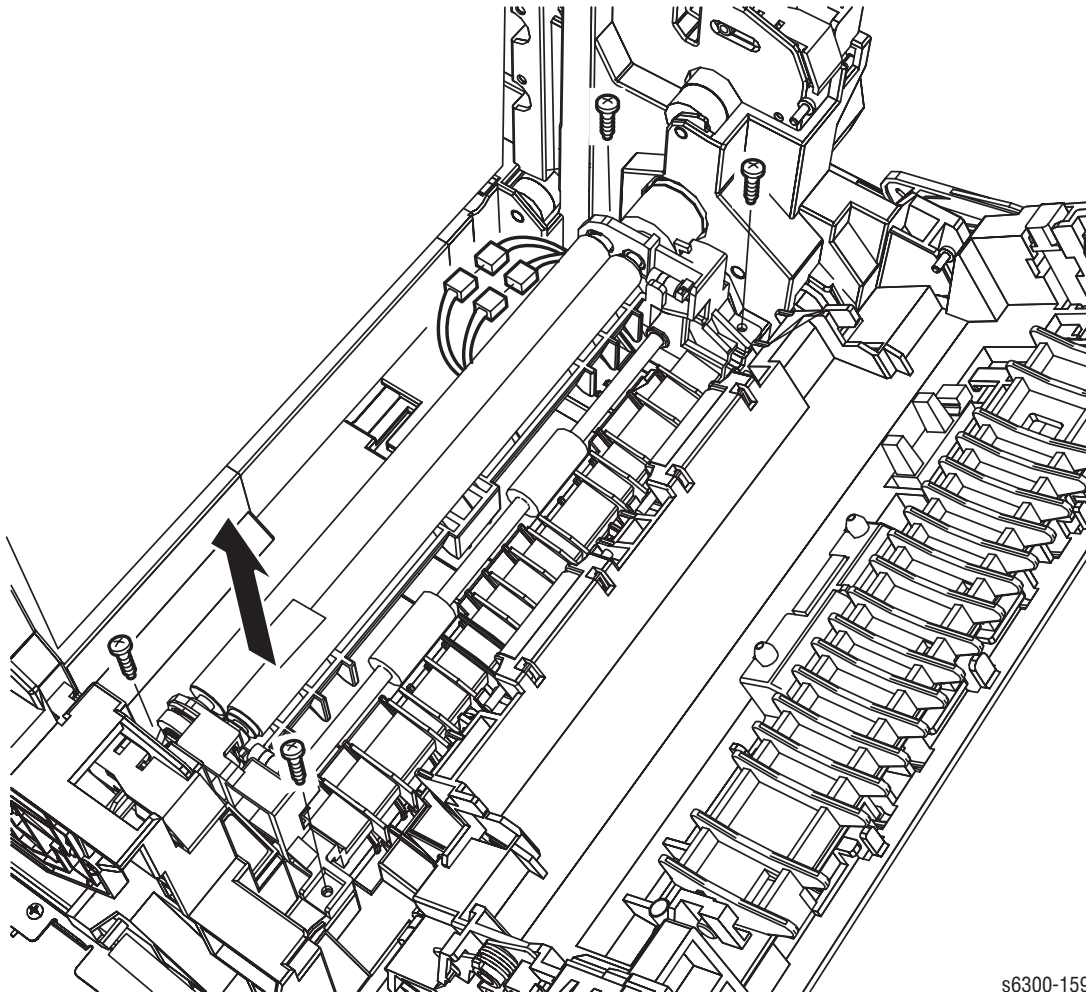

s6300-159

Replacement Note

Insert the Registration Clutch into the opening first. Lower the opposite end as the clutches mesh with the gears. Carefully re-route the sensor harnesses through the bottom harness guides to prevent damage to the wiring or Imaging Unit seating errors.

Tray 1 (MPT)

Tray 1 (MPT) (PL1.1.23)

1. Remove the Left Front Cover (page 8-18).
2. Spread the right and left slots of the Tray 1 (MPT) Cover outward, pull out the left and right bosses to release Tray 1 (MPT) from the cover.
3. Open Door B.
4. Release the left side boss of Tray 1 (MPT) by rotating the Left Tray Holder clockwise to remove it.

Note

The right side bushing is not captive. Note the Bearing's orientation as you remove it.

5. Move Tray 1 (MPT) to the right to release the left boss from the frame and pull the right boss and bushing from the right side to remove the tray.

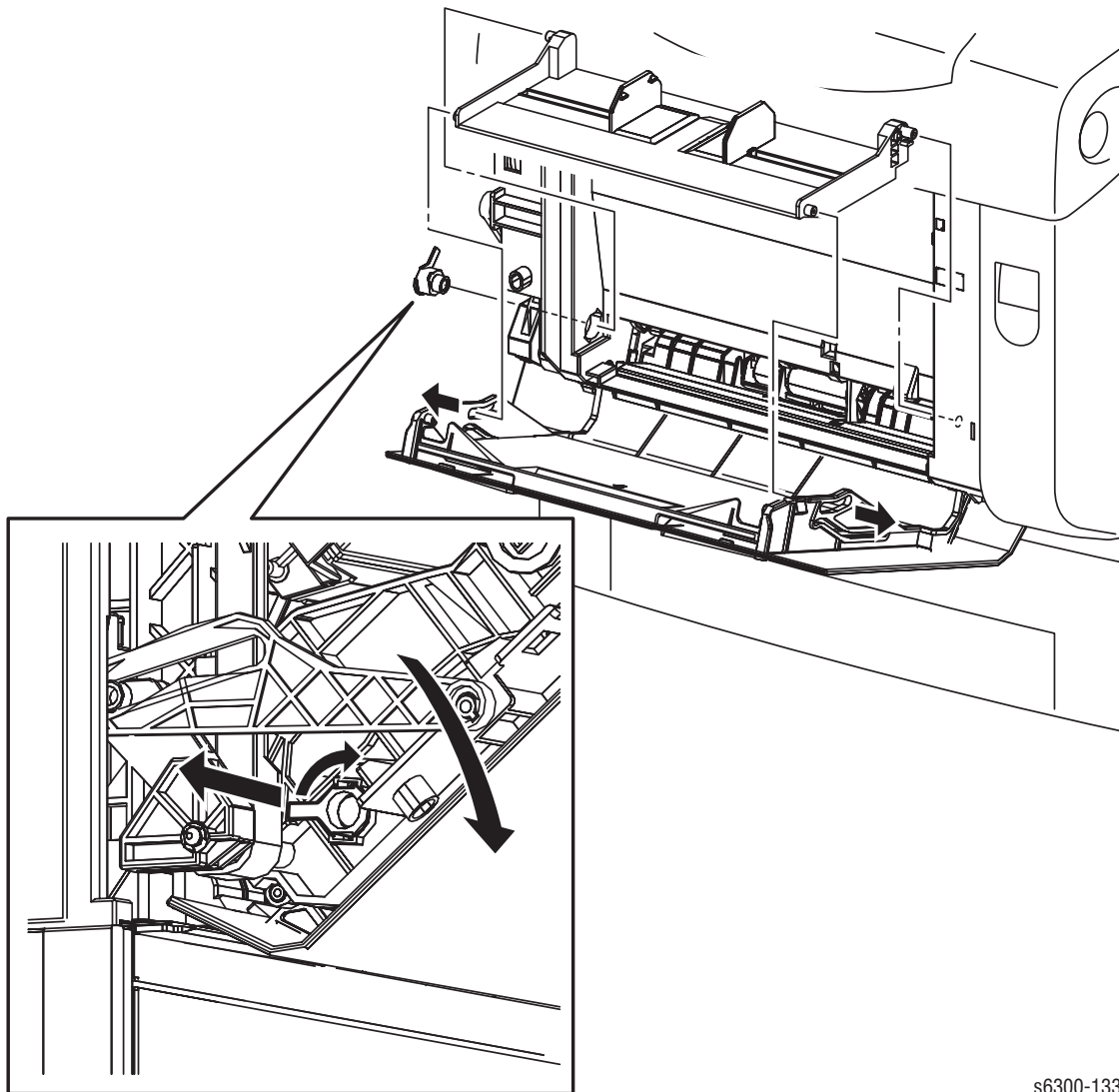

s6300-133

Replacement Note

Rotate the Tray Holder beyond the stop to lock it in place.

Tray 1 (MPT) Cover (PL1.1.27)

1. Open Tray 1 (MPT).
2. Spread the right and left slots of the Tray 1 (MPT) Cover outward, pull out the left and right bosses of Tray 1 (MPT).
3. Move the cover to the right to release the two bosses at the bottom of the Tray 1 (MPT) Cover.

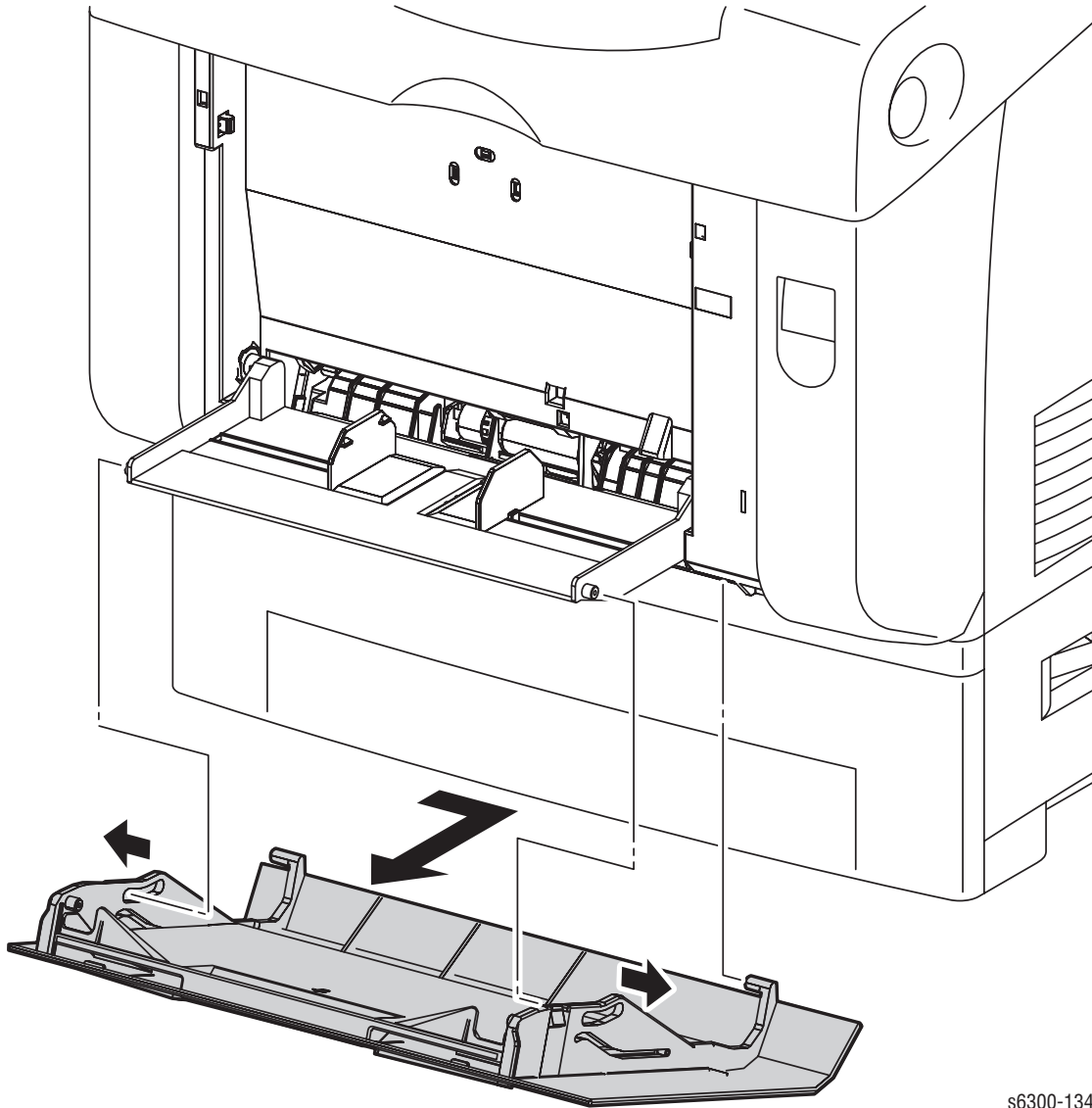

s6300-134

Tray 1 (MPT) Feed Solenoid (PL5.3.9)

1. Remove the Top Main Cover (page 8-8).
2. Remove the Left Side Cover (page 8-13).
3. Remove the Right Front Cover (page 8-17).
4. Remove the Right Side Cover (page 8-12).
5. Open Door B.
6. Remove the Tray 1 (MPT) Feed Solenoid connector (P/J132) from the Front Harness Guide on the right side of the printer and disconnect the connector.

Caution

Use care when cutting the cable tie binding the harness bundle.

7. Cut the cable tie binding the harness at the right front corner of the printer and remove the Tray 1 (MPT) Feed Solenoid harness from the bundle.

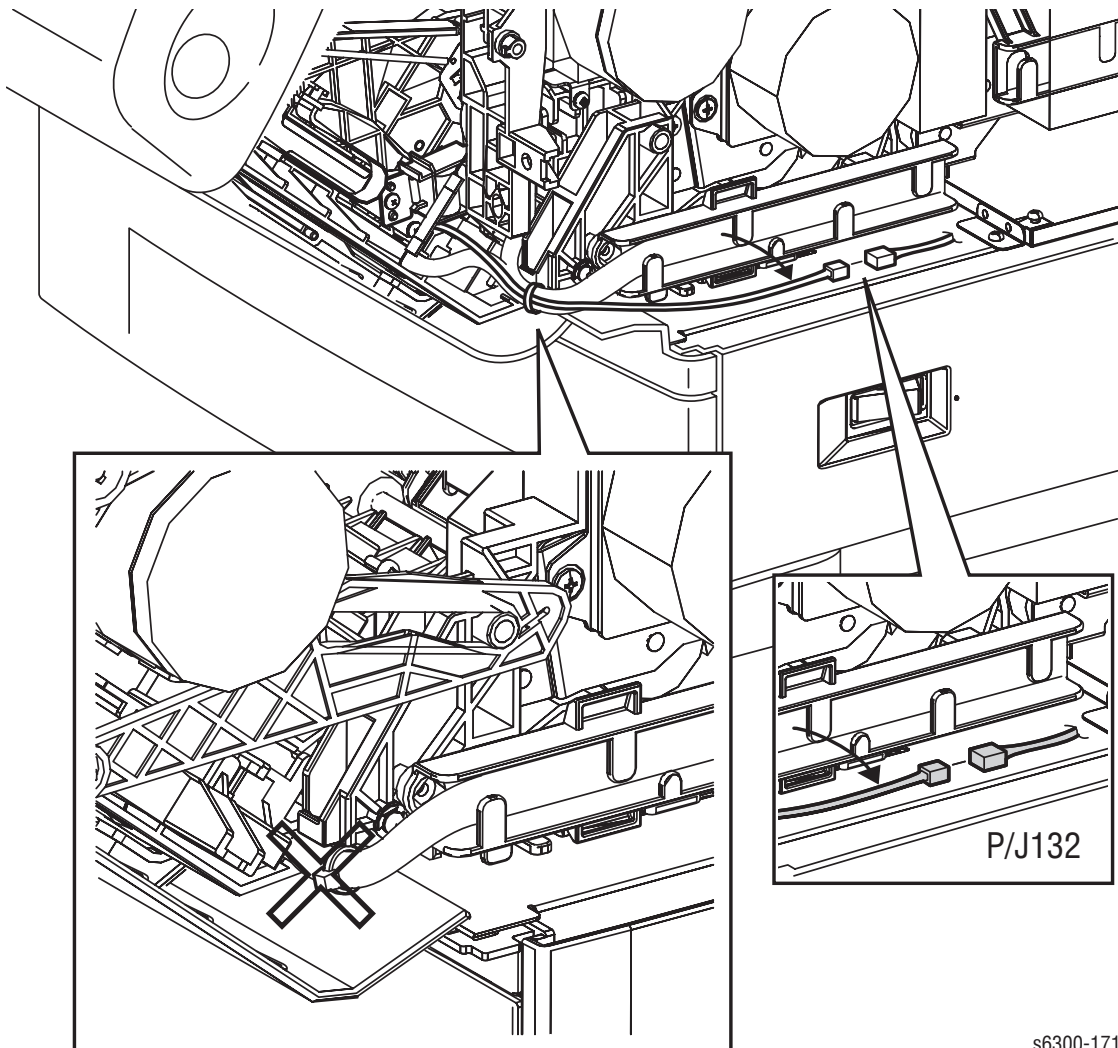

8. Disconnect the Control Panel Harness (P22) from the Engine Control Board and remove the harness from the Front Harness Guide.

9. Remove the Spring and Link on the left side of the frame.

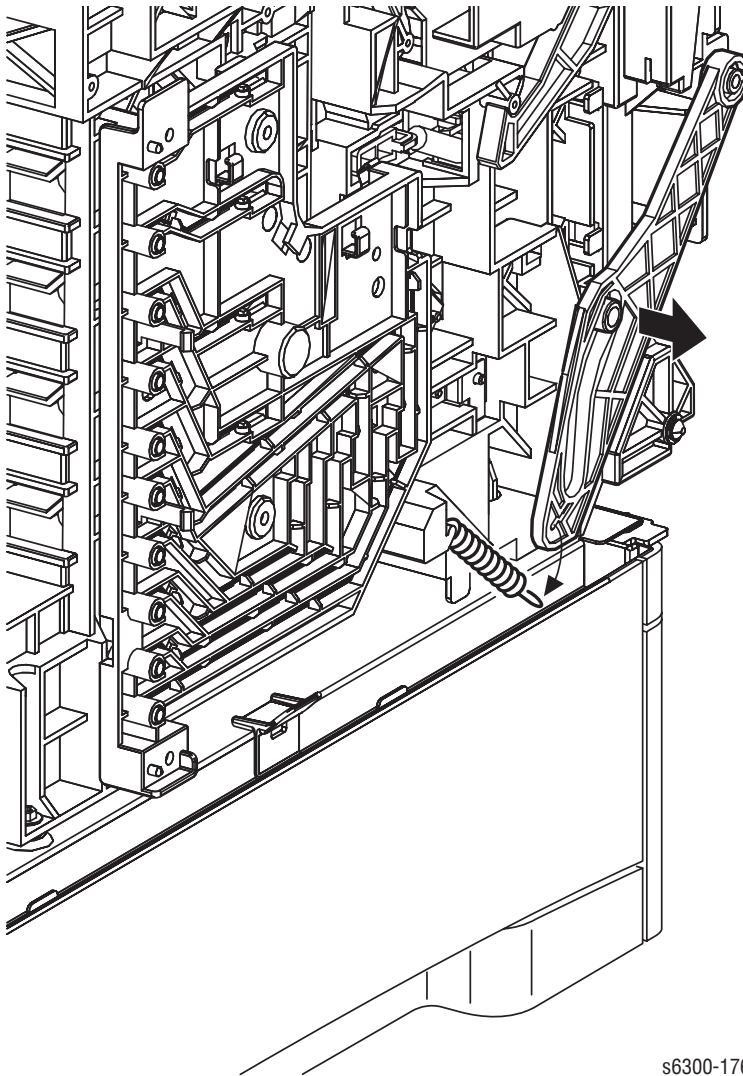

s6300-176

10. Remove the Spring and Link from the right side of the printer.

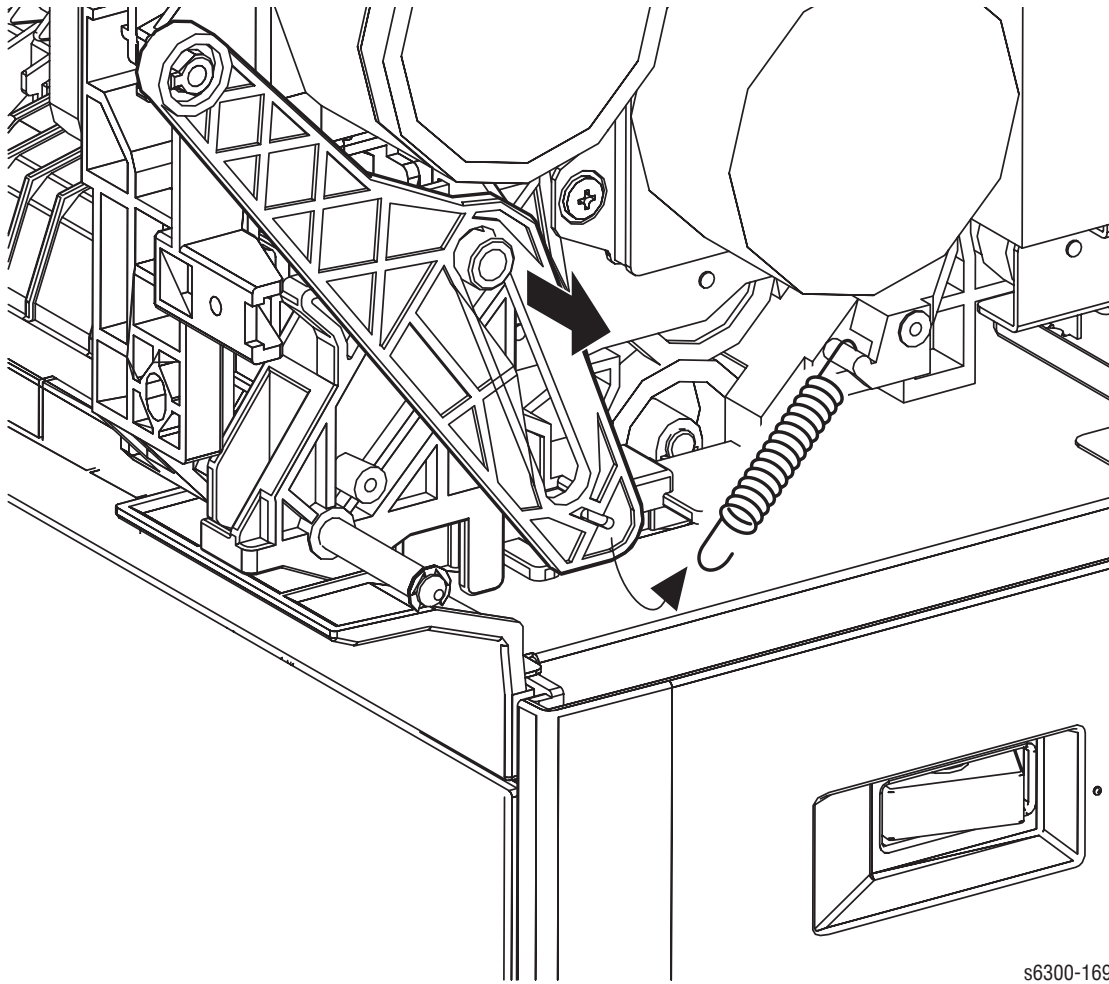

s6300-169

11. Lower Door B to a supporting surface.

12. Remove the Gear MPT and attached spring from the shaft. Leave the spring attached to the printer.
13. Remove the screw that secures the Tray 1 (MPT) Feed Solenoid and the ground wire to the Chute Assembly Out.
14. Remove the Tray 1 (MPT) Feed Solenoid.

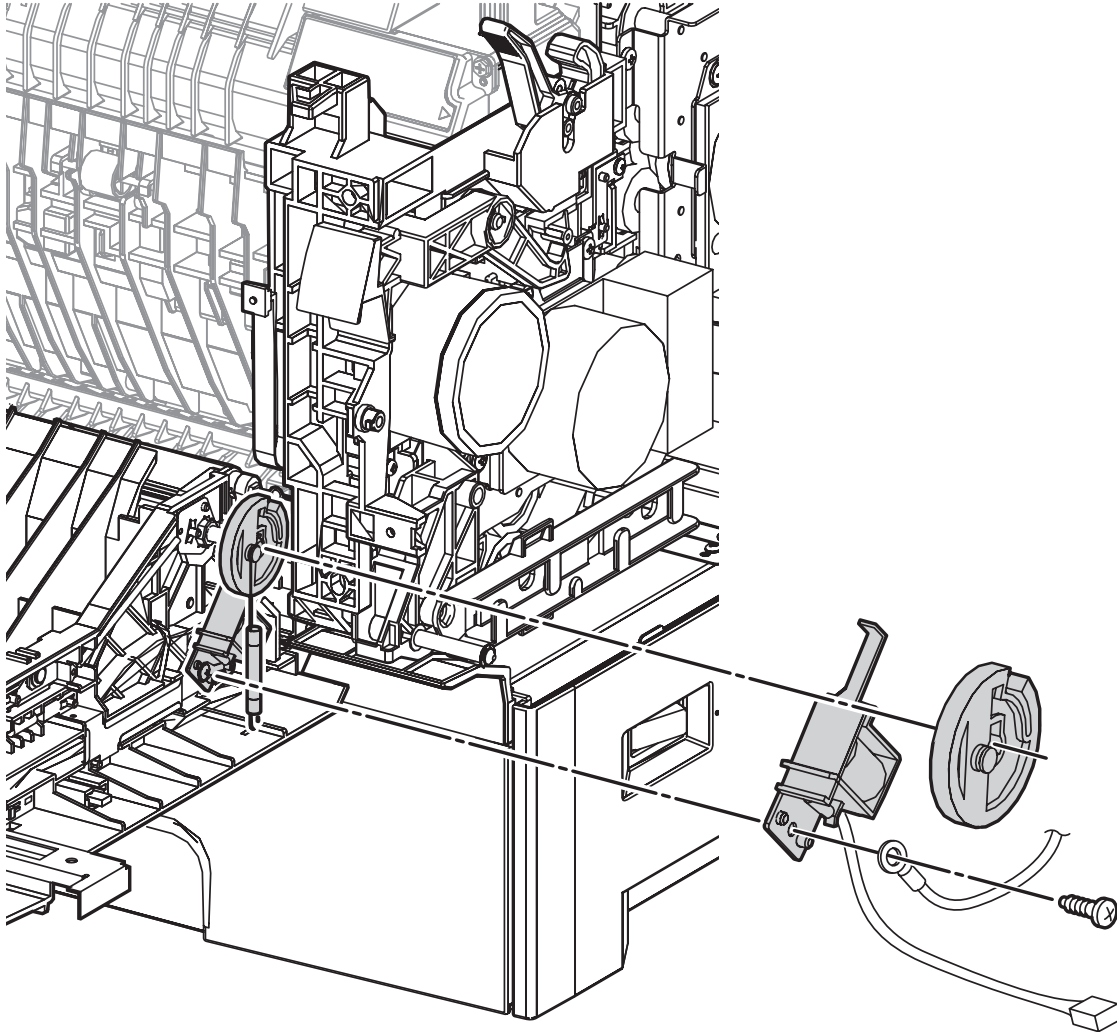

s6300-172

Replacement Note

After servicing the Feed Solenoid, replace the cable tie and verify routing of the harness bundle. Make certain that repeated door operation does not abrade the harness bundle.

Tray 1 (MPT) No Paper Sensor and Actuator (PL5.3.14)

1. Remove the Top Main Cover (page 8-8).
2. Remove the Left Side Cover (page 8-13).
3. Open Door B.
4. Release the hook to remove the Stopper Strap from Door B.

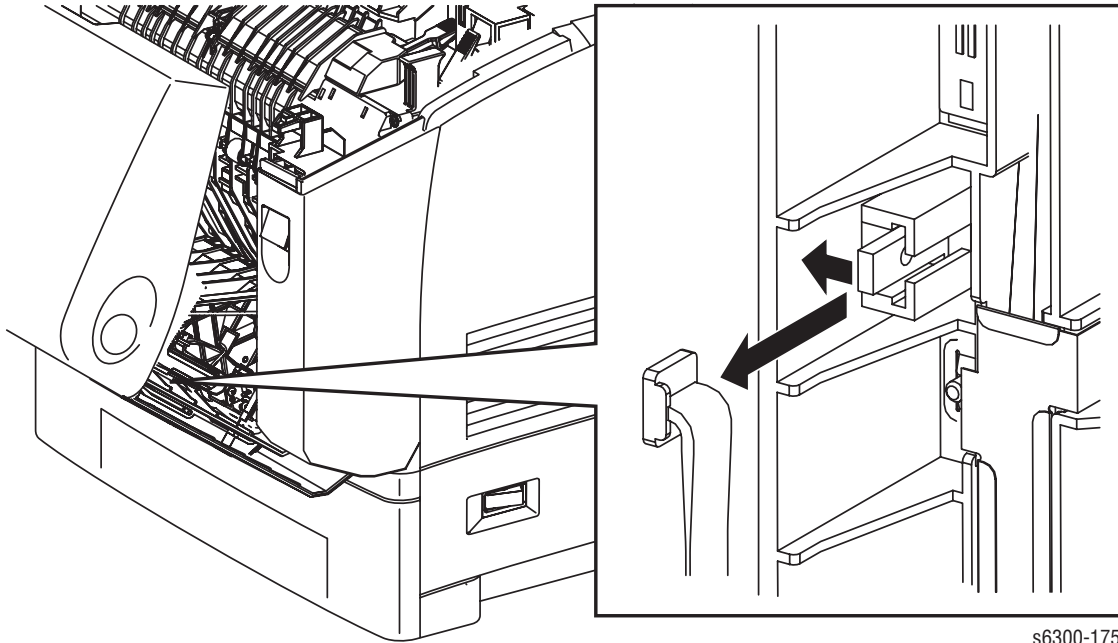

s6300-175

5. Close Door B.

Caution

Hold the Door B after releasing the Link and spring to prevent it from falling open. Gently lower Door B to the supporting surface.

6. Remove the Spring and Link on the left side of the frame.

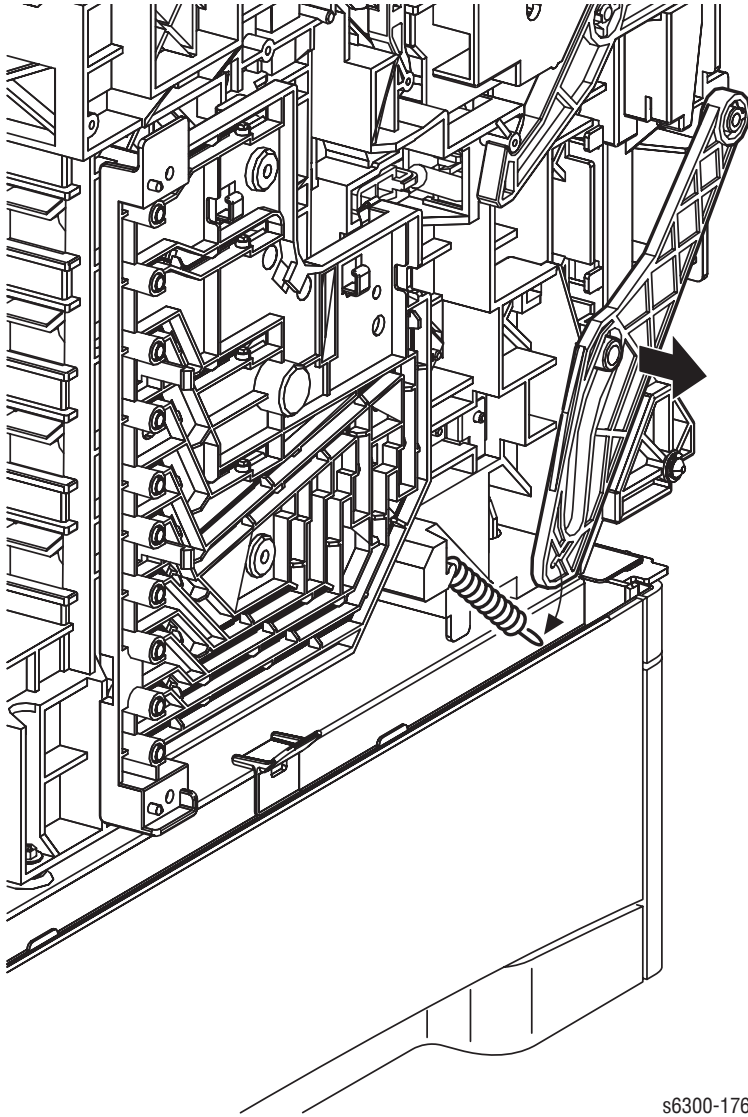

s6300-176

7. Fully open Door B.

8. Release the 4 hooks that secure the actuator cover to the Chute Assembly Out.
9. Remove the No Paper Sensor Actuator from the notch of the Chute Assembly Out and pull out the other end of the actuator through mounting hole to remove it.

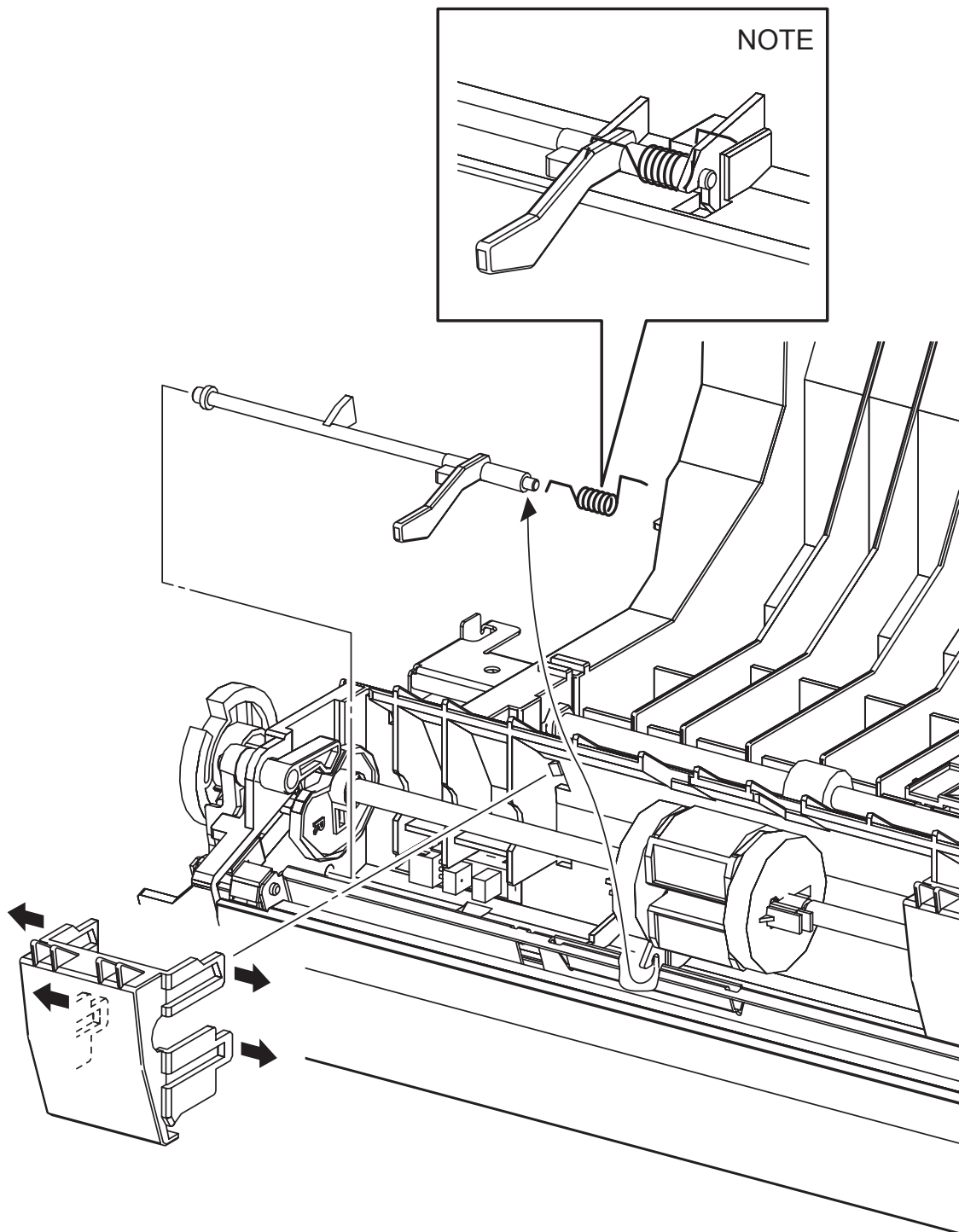

s6300-174

10. Release the hooks that secures the Tray 1 (MPT) No Paper Sensor to the Chute Assembly Out and remove the sensor with the harness.
11. Unplug connector (P/J135) from the Tray 1 (MPT) No Paper Sensor.

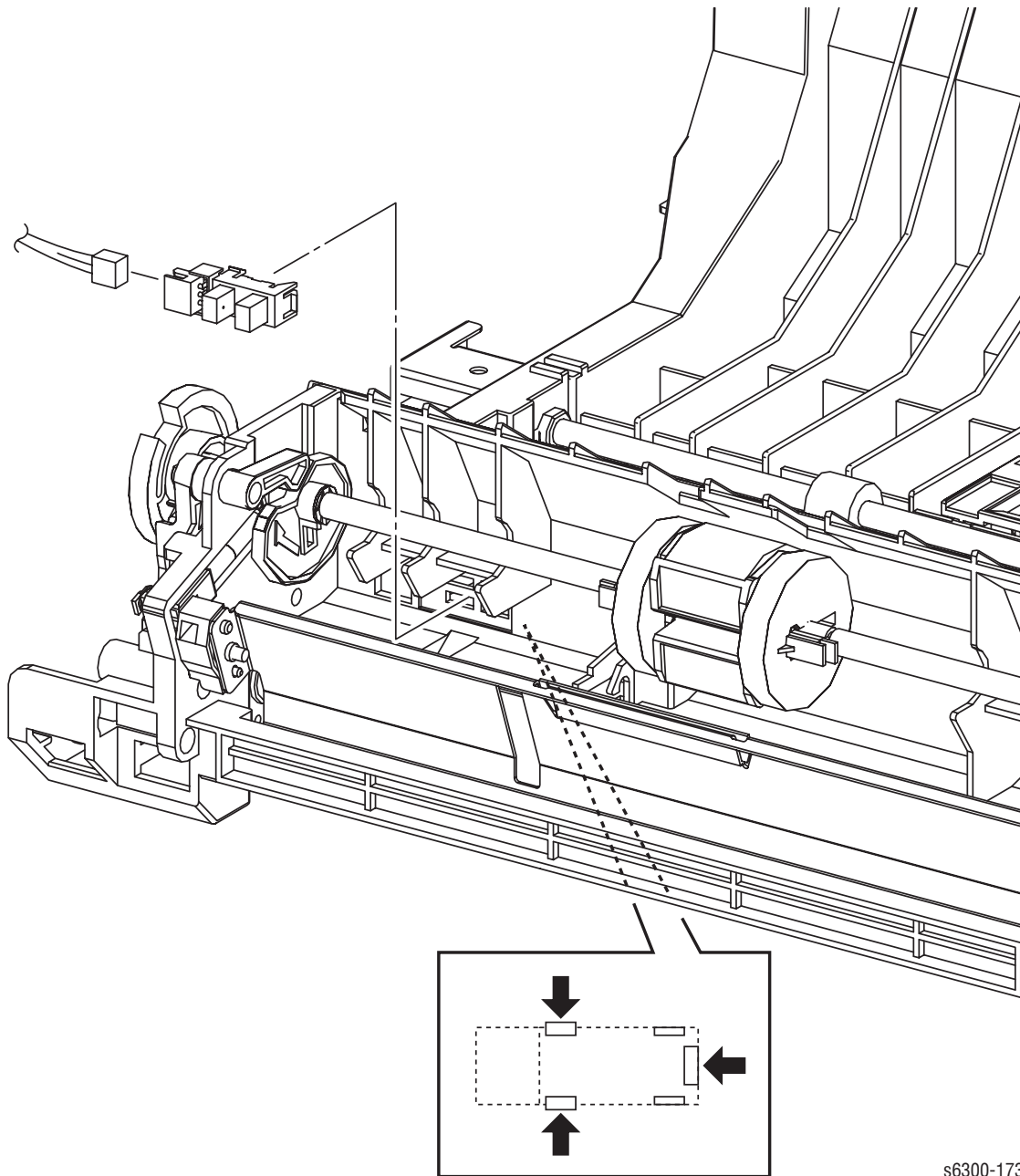

s6300-173

Tray 1 (MPT) Feed Roller (PL5.3.20)

1. Remove the Left Front Cover (page 8-18).
2. Remove the Left Side Cover (page 8-13).
3. Open Door B.
4. Release the hook to remove the Strap from Door B.

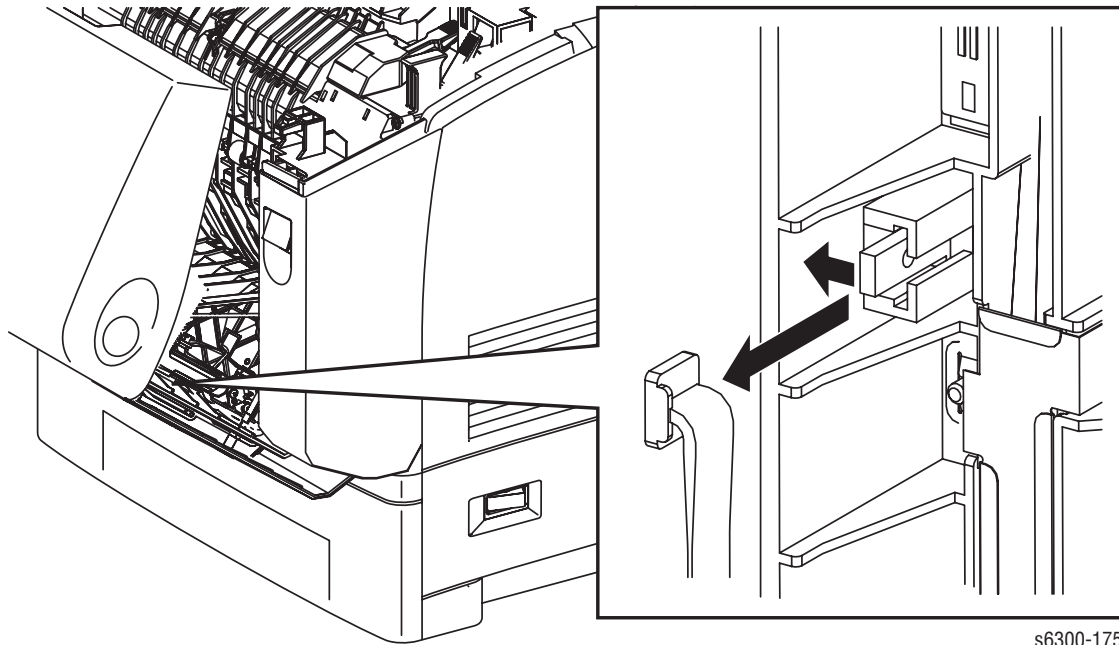

s6300-175

5. Close Door B.

Caution

Hold the Chute Assembly Out after releasing the Link and spring to prevent the chute from falling open. Gently lower the chute to the supporting surface.

6. Remove the Spring and Link on the left side of the frame.

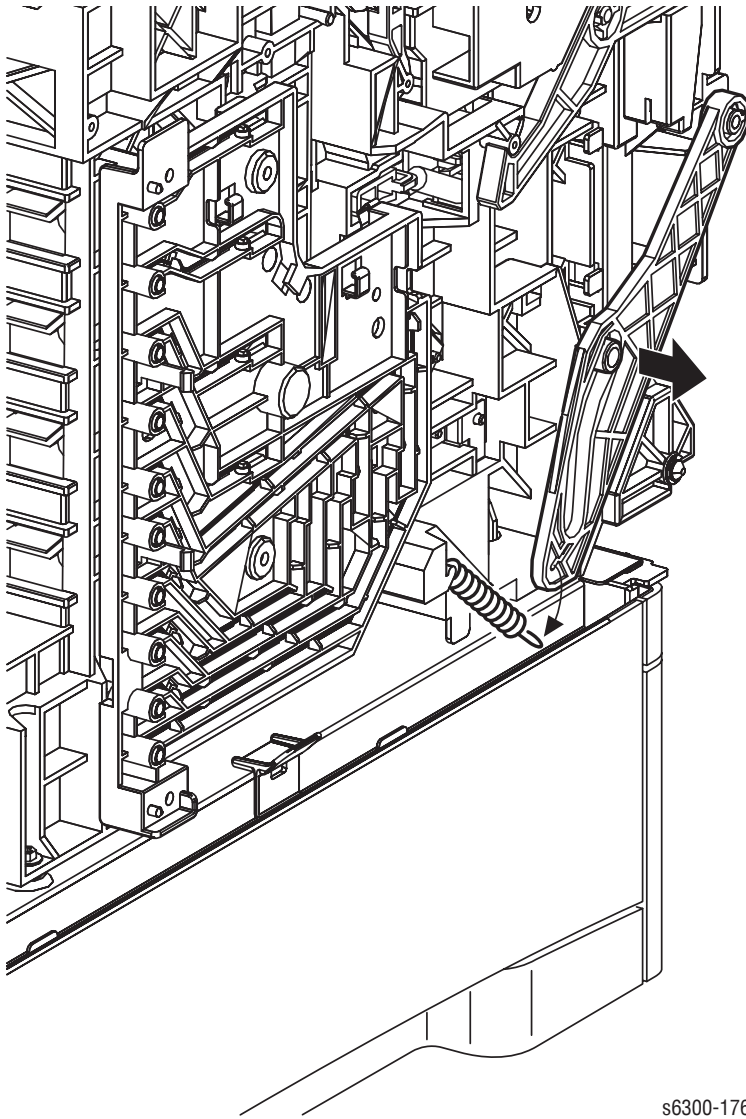

s6300-176

7. Fully open Door B.

8. Release the hook that holds the left side Roll Core on the Shaft, move the Roll Core to the left.
9. Move the Feed Roller left until the pin on the shaft appears and remove the Feed Roller.

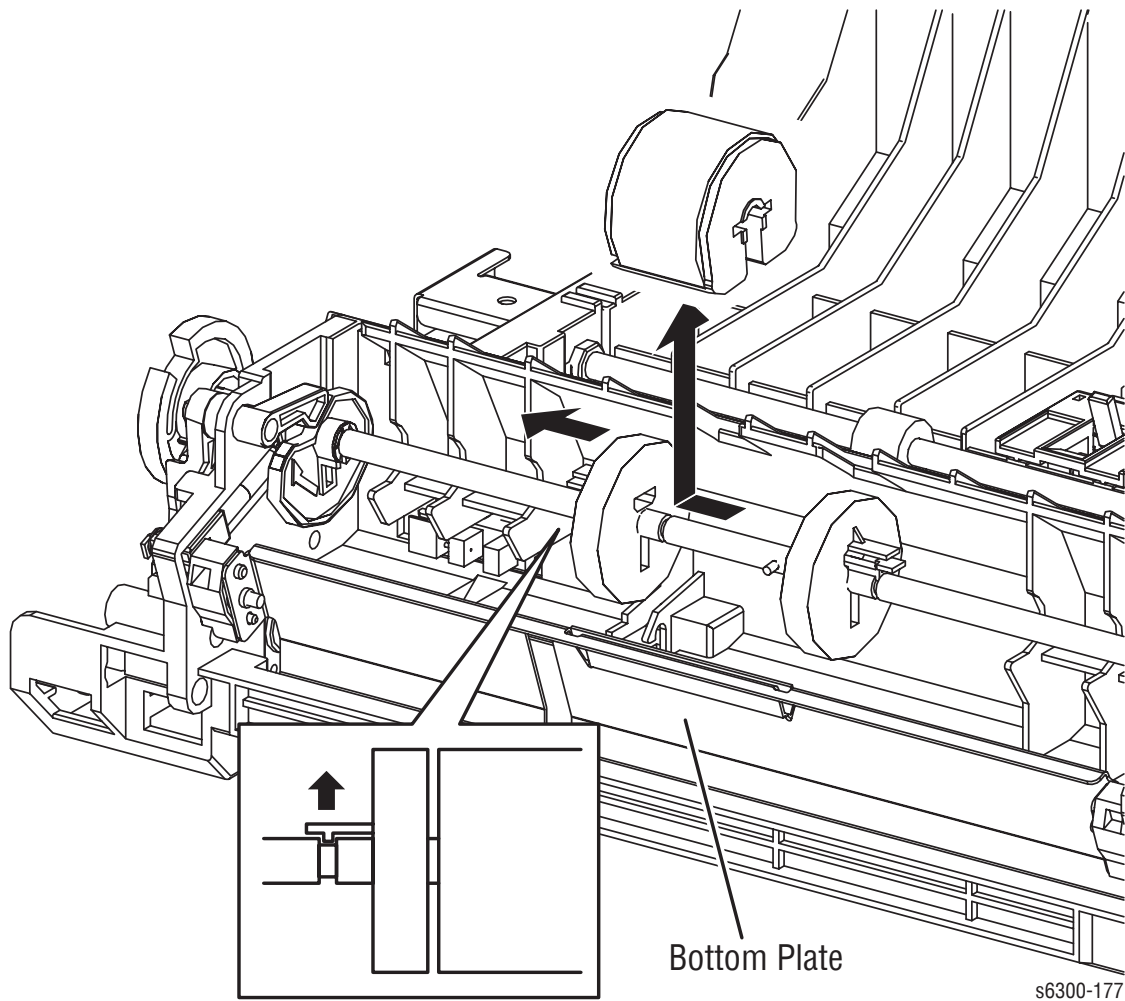

Replacement Note

With the Solenoid engaged, the flat portion of the Feed roller should face the Bottom Plate.

Chute Assemblies

Full Stack Sensor (PL5.4.1)

1. Remove the Front Cover (page 8-10).
2. Unplug connector (P/J134) from the Full Stack Sensor.
3. Lift the actuator to clear the sensing area and release the 3 hooks that secure the Full Stack Sensor to the Chute Assembly Out.

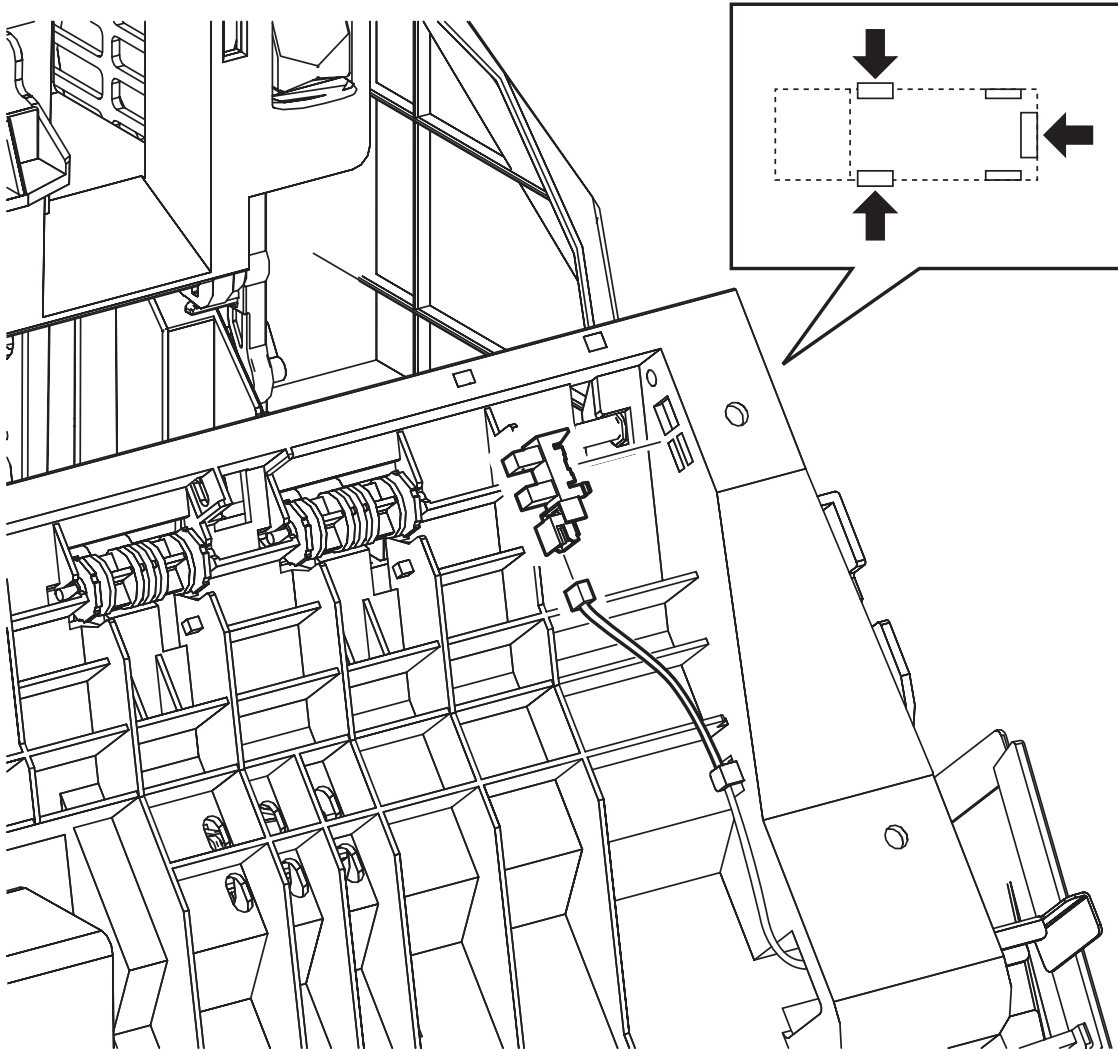

s6300-178

Full Stack Actuator (PL5.4.2)

1. Remove the Front Cover (page 8-10).
2. Bend the middle of the Full Stack Actuator somewhat and remove the left and right ends from the mounting holes.

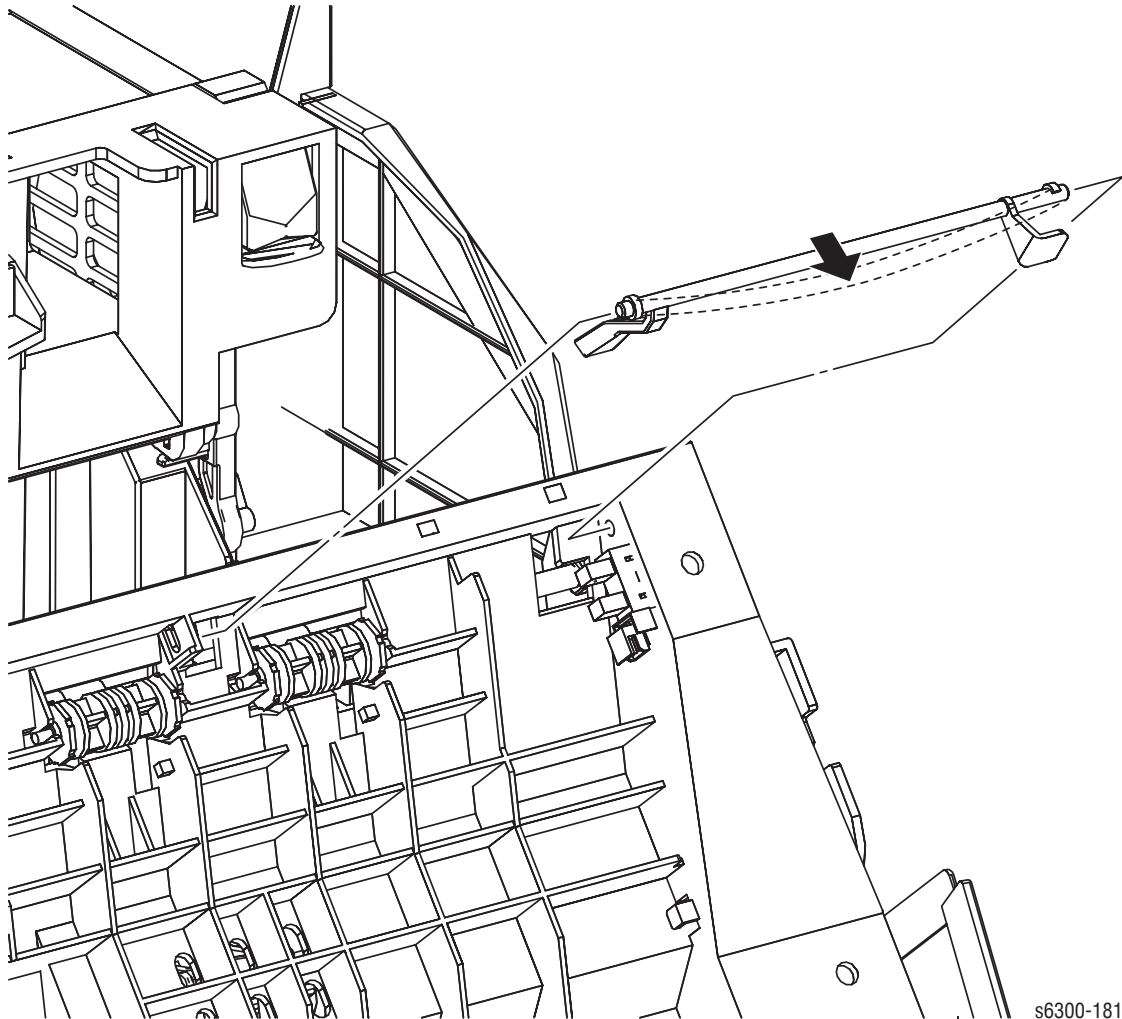

Duplex Jam Sensor (PL5.4.1) and Actuator (PL5.4.13)

1. Open Tray 1 (MPT).
2. Open Door B.
3. Release the 3 hooks that secure the Duplex Jam Sensor Holder to the Chute Assembly Out.

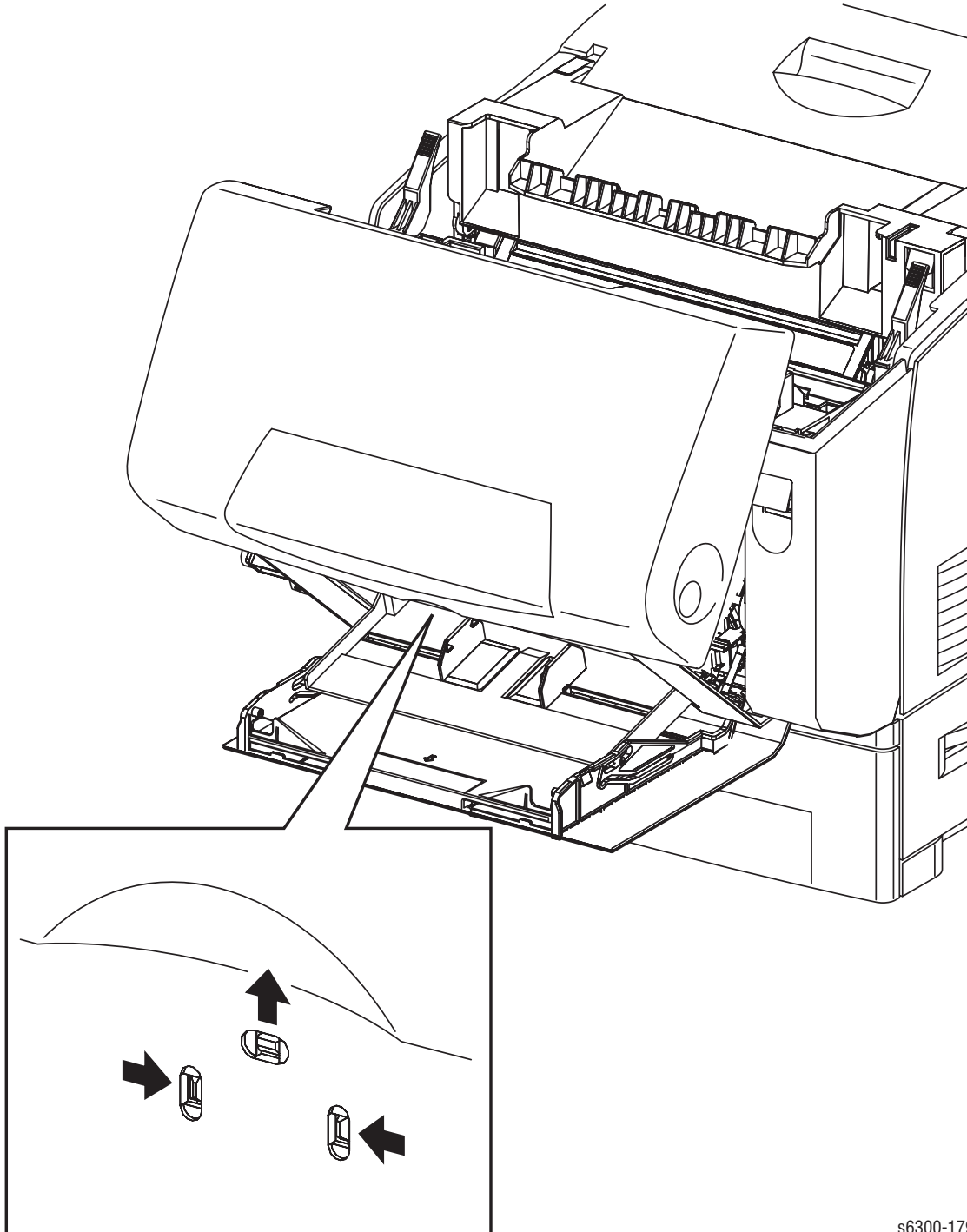

s6300-179

4. Unplug connector (P/J133) from the Duplex Jam Sensor.
5. Release the 3 hooks that secure the Duplex Jam Sensor to the holder.

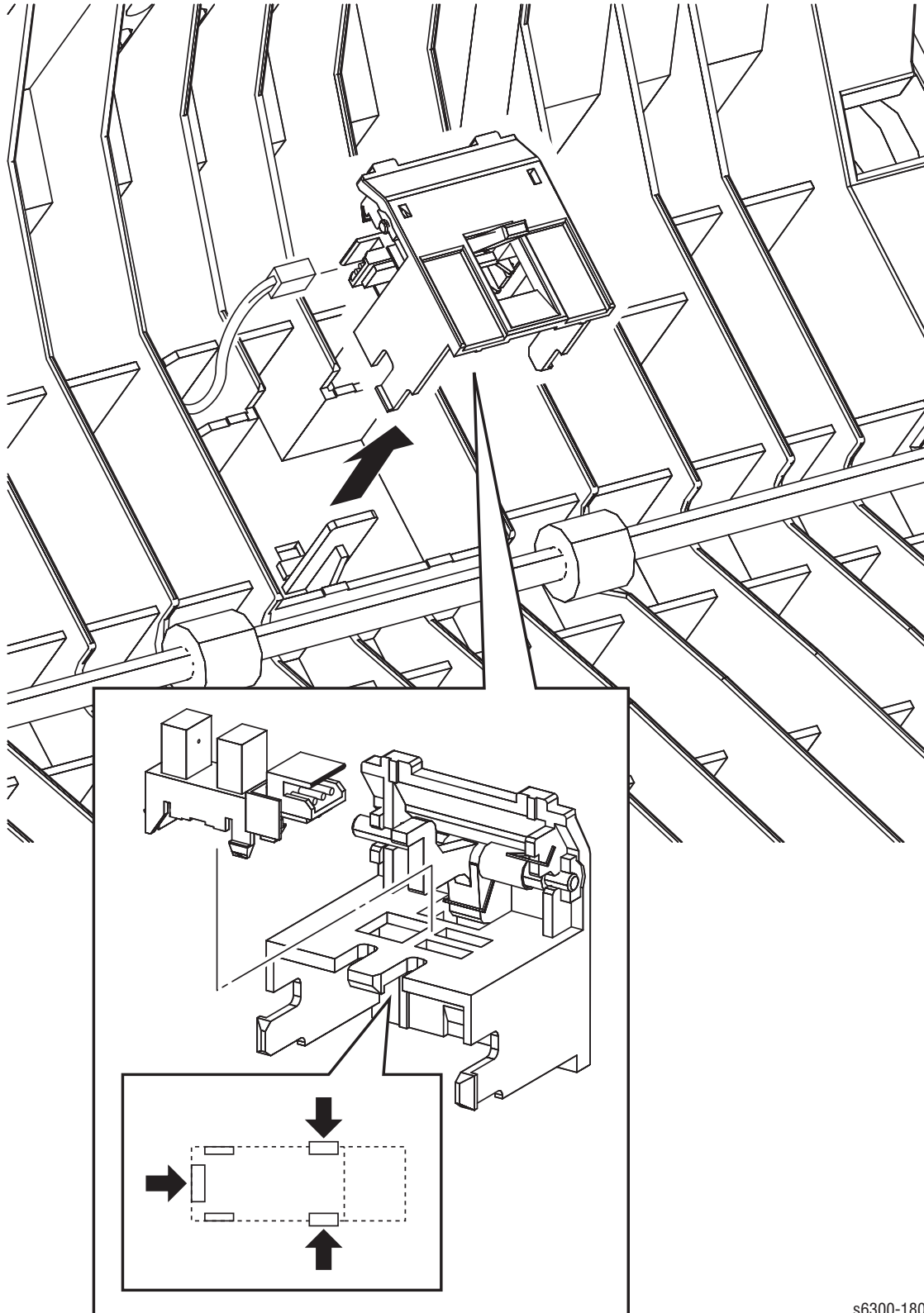

s6300-180

6. Press the shaft of the actuator through the 2 holes in the holder with a miniature screwdriver to remove the Duplex Jam Sensor Actuator.

7. Remove the spring from the actuator.

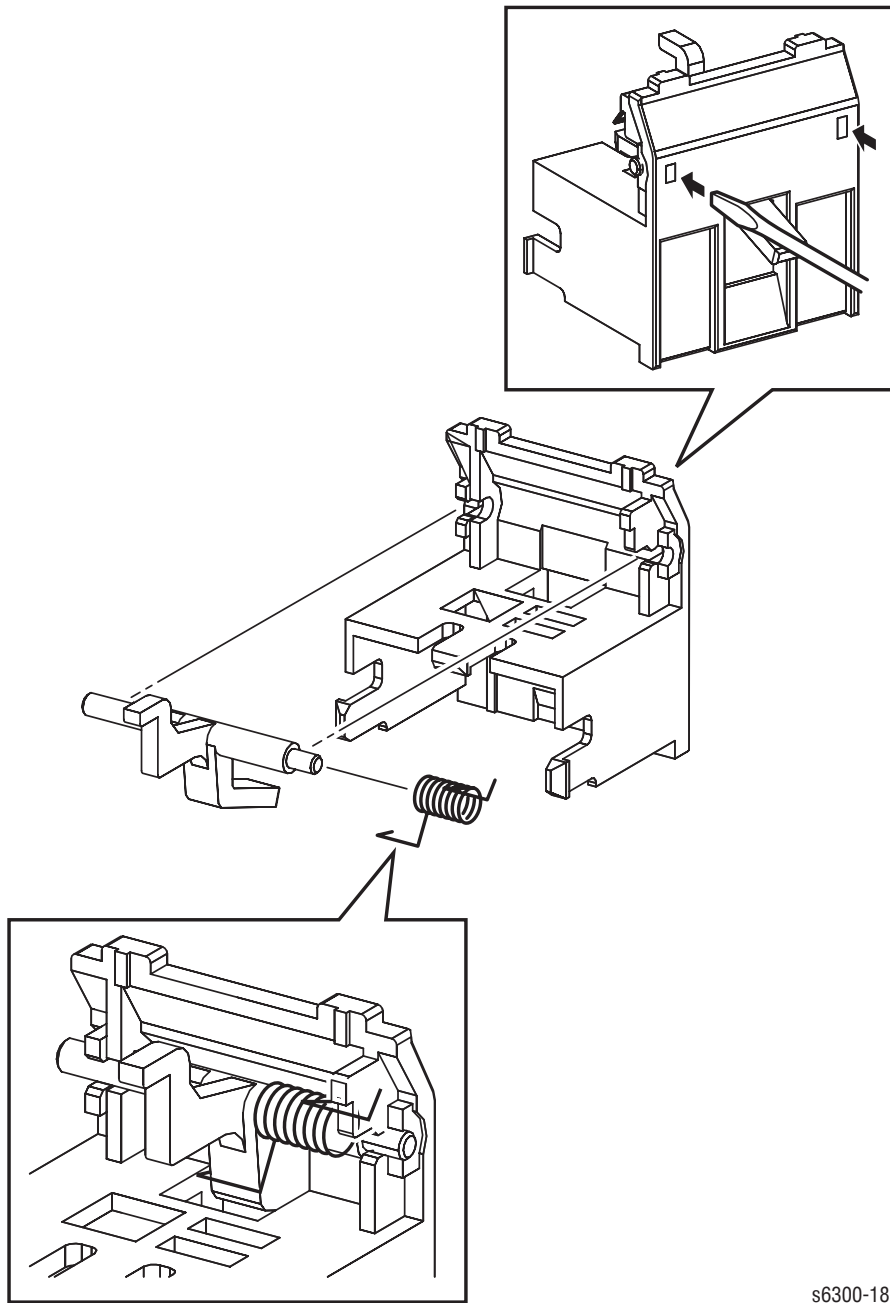

s6300-183

Replacement Note

Verify the proper orientation, attachment of the spring and function of the actuator.

Duplex Motor Assembly (PL5.4.5)

1. Remove the Front Cover (page 8-10).
2. Release the hook on the Exit Gear that secures it to the Exit Roller and remove it.
3. Remove Gear 52.
4. Release the hook on Exit Gear that secures it to the Duplex Roller and remove it.
5. Remove the two Gear 41s.
6. Remove the two screws (silver, 6mm) that secure the Gear Cover and remove the two Gears 40/66H that engage the Duplex Motor.
7. Unplug connector (P/J501) from the Duplex Motor harness.
8. Remove 2 screws (silver, 6mm) that secure the Duplex Motor to the Chute Assembly Out.

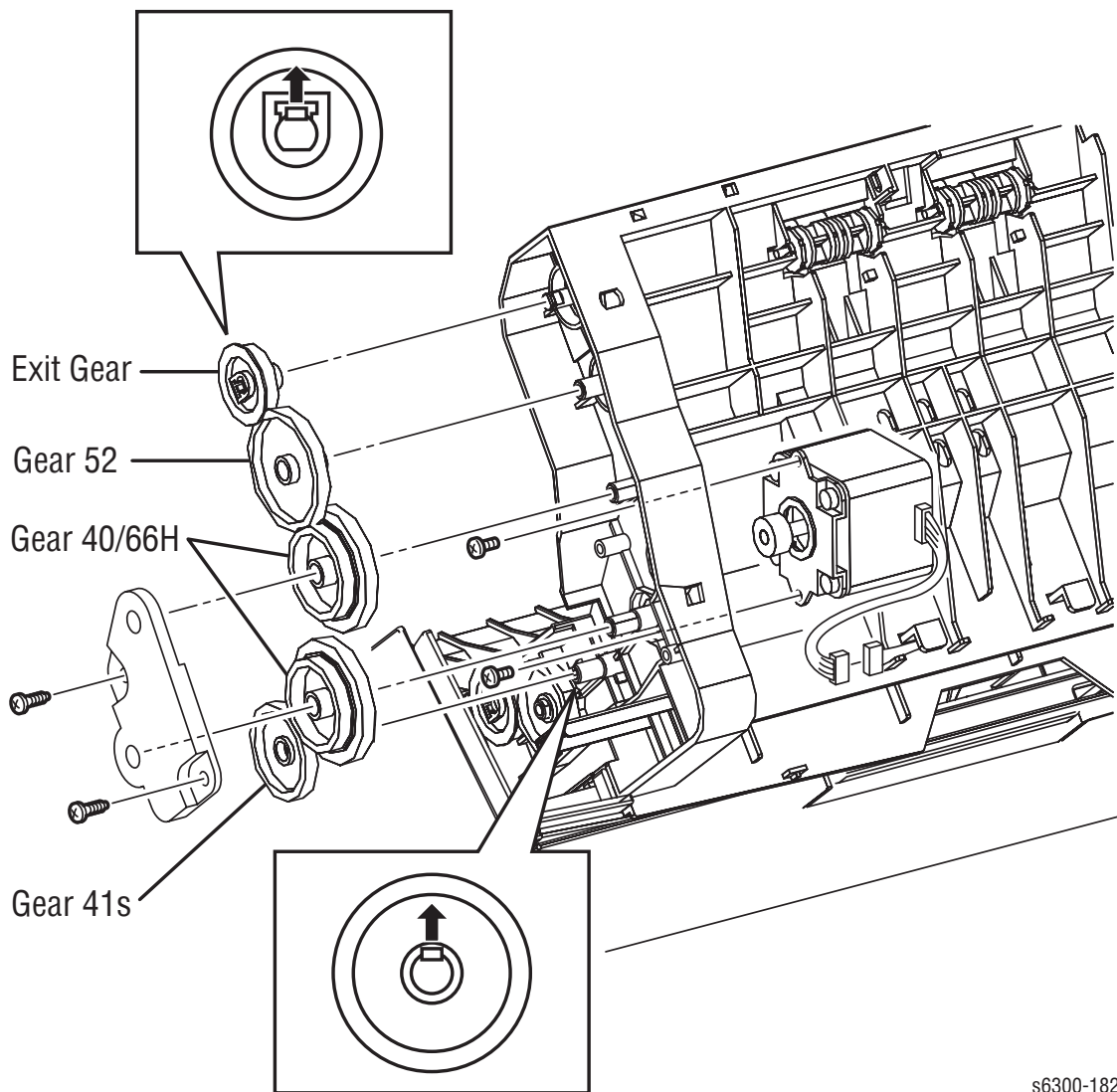

s6300-182

Replacement Note

A duplex gear arrangement diagram appears on (page 2-36).

Chute Assembly In (PL5.2.1)

1. Remove the Top Main Cover (page 8-8).
2. Remove the Front Cover (page 8-10).
3. Remove the Right Front Cover (page 8-17).
4. Remove the Left Front Cover (page 8-18).
5. Remove the Right Side Cover (page 8-12).
6. Remove the Left Side Cover (page 8-13).
7. Remove Tray 1 (MPT) (page 8-39).
8. Remove the Tray 1 (MPT) Cover (page 8-40).
9. Remove the Fuser (page 8-67).
10. Remove the Transfer Roller (page 8-70).
11. Remove the Chute Assembly Out (page 8-61).
12. Remove a screw (silver, provided with external tooth washer, 5 mm) that secures the ground wire on the right side of the bottom plate.
13. Unplug connector (P/J162) from the LVPS.
14. Remove the the Harness Guide Clamp from the Rear Harness Guide.
15. Remove the two screws (self-tapping, plastic 10 mm) that secure the Front Harness Guide and remove the guide.

16. Remove the FSR Harness from the Front and Rear Harness Guides.

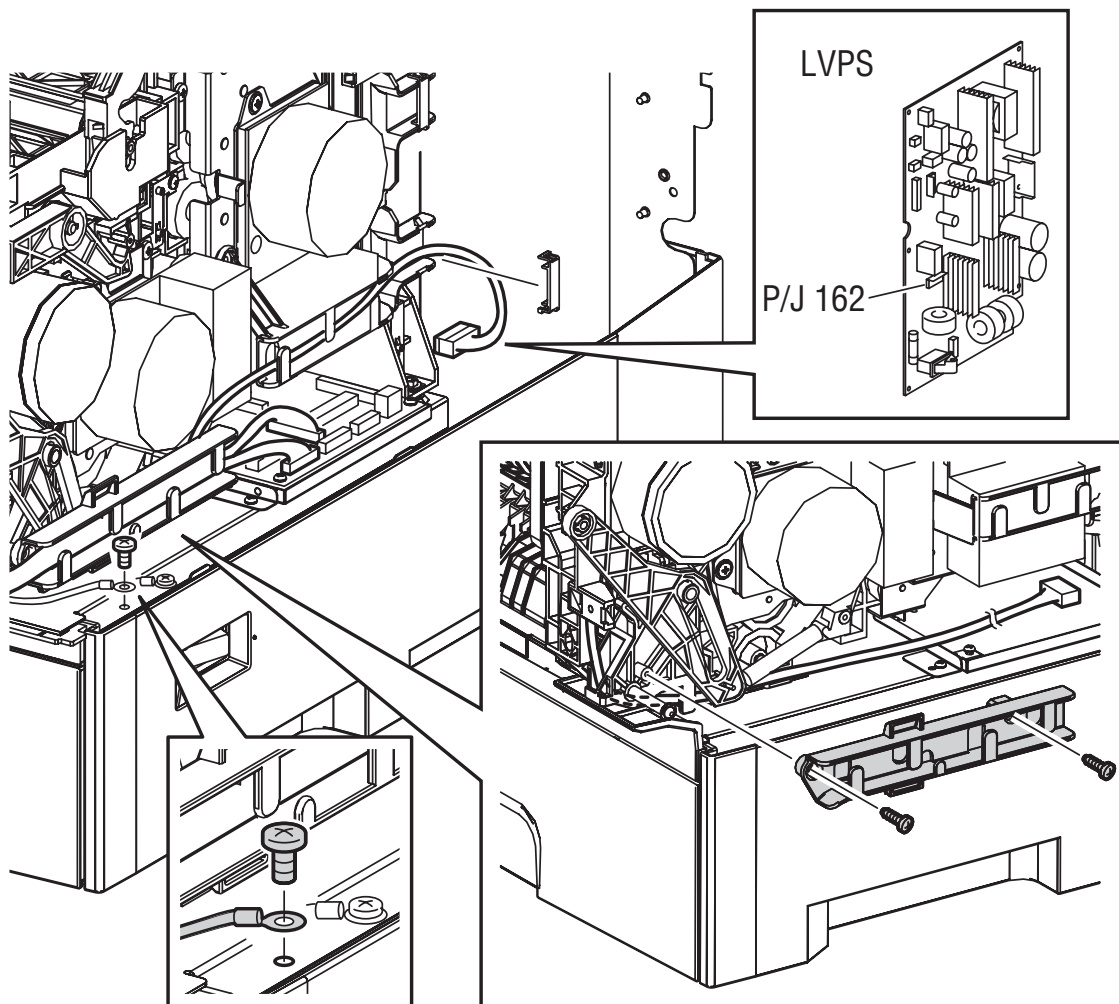

s6300-186

17. Holding the Chute Assembly In, push in the right and left pivot pins and remove the Chute Assembly In.

Replacement Note

Install the shorter of the two pivot pins into the left side of the printer.

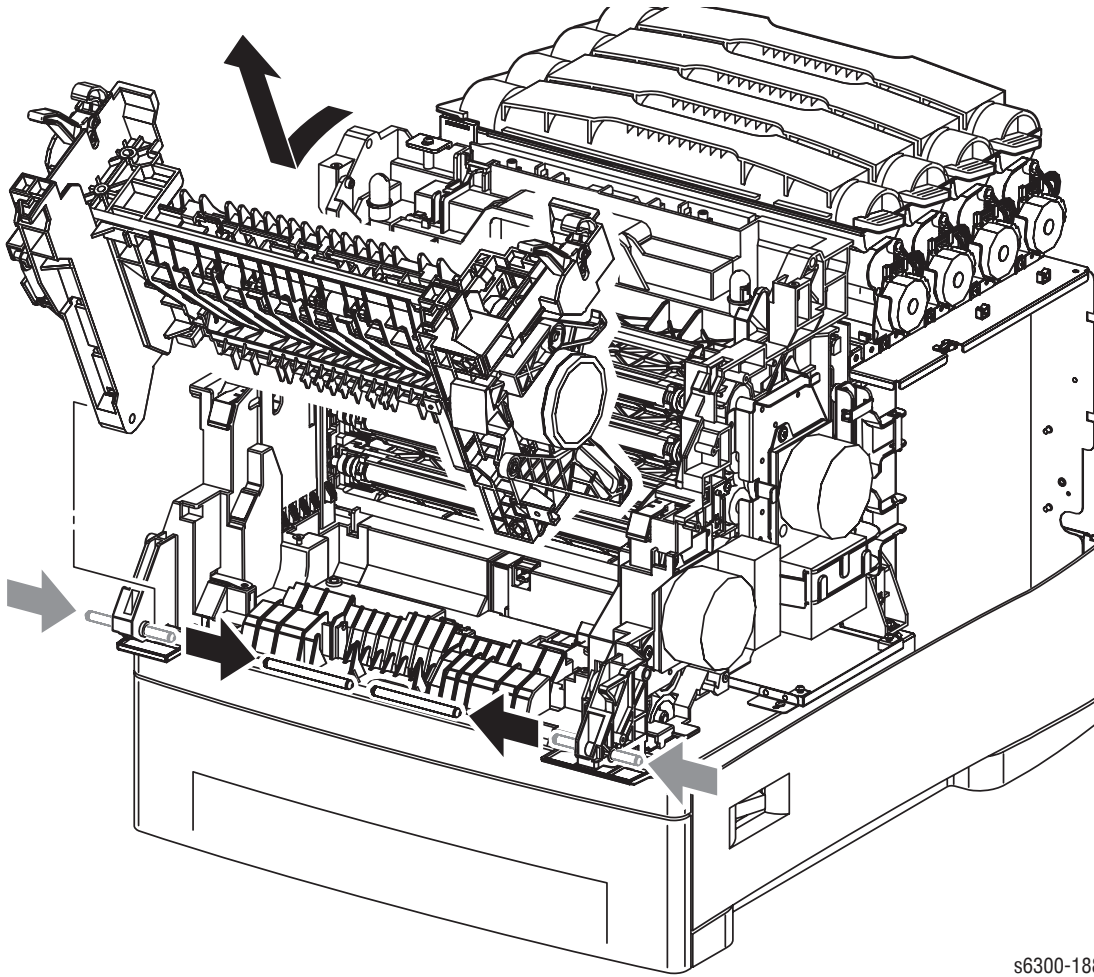

s6300-188

Chute Assembly Out (PL5.3.1)

1. Remove the Top Main Cover (page 8-8).
2. Remove the Front Cover (page 8-10).
3. Remove the Right Front Cover (page 8-18).
4. Remove the Left Front Cover (page 8-18).
5. Remove the Right Side Cover (page 8-12).
6. Remove the Left Side Cover (page 8-13).
7. Remove Tray 1 (MPT) (page 8-39).
8. Remove the Tray 1 (MPT) Cover (page 8-40).
9. Remove the screw (metal with tooth washer, 5 mm) that secures the Tray 1 Feed Solenoid ground wire to the right side of the bottom plate and remove the wire from the Front Harness Guide.

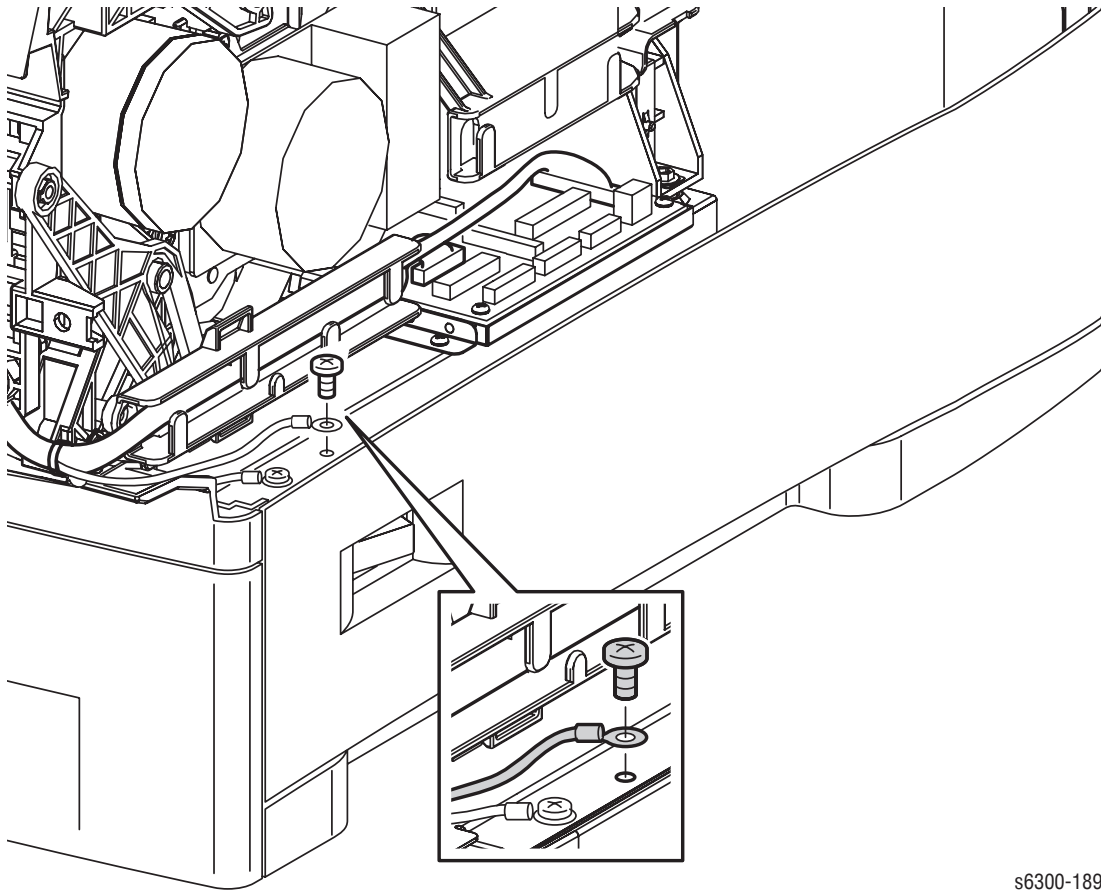

s6300-189

10. Disconnect P/J710 (Imaging Unit CRUM connector), Developer Drive Assembly (P/J491), and the Main Drive Assembly (P/J481) and remove the harnesses from the cable guides.

11. Unplug connectors (P/J13 and P/J22) from the Engine Control Board and remove the harnesses from the Front Harness Guide.

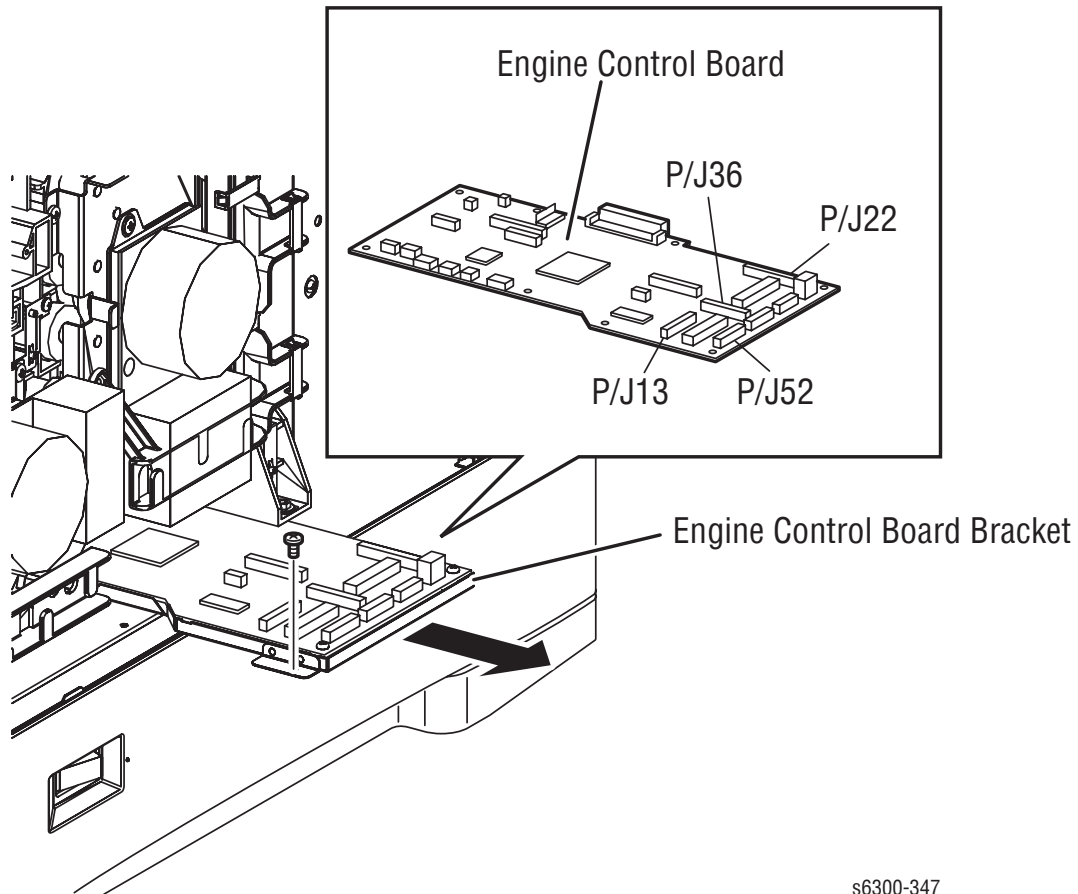

s6300-347

Note

If removing the Chute Assembly In, also unplug connectors (P/J36 and P/J52) and remove these harnesses from the Front Harness Guide.

- 12.** Remove the Link Spring from the left side of the printer.

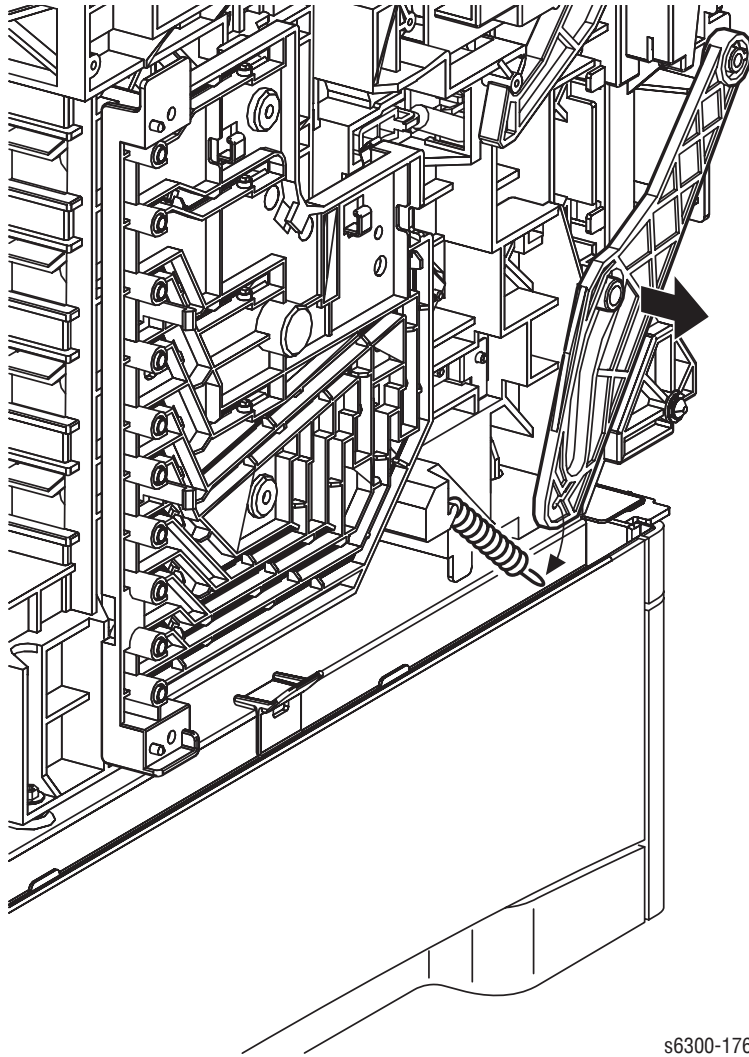

s6300-176

- 15.** Remove the boss from the hole of the center of the Link on the left side of the printer.
- 16.** Release the hook that fixes the Stopper strap and remove the Stopper.

17. Remove 2 E-rings that secure the Right and Left Pivot Shafts from the underside of Chute Assembly Out.
18. Close Door A if open.
19. Holding the Chute Assembly Out, push the Right and Left Pivot Shafts in by approximately half their length.

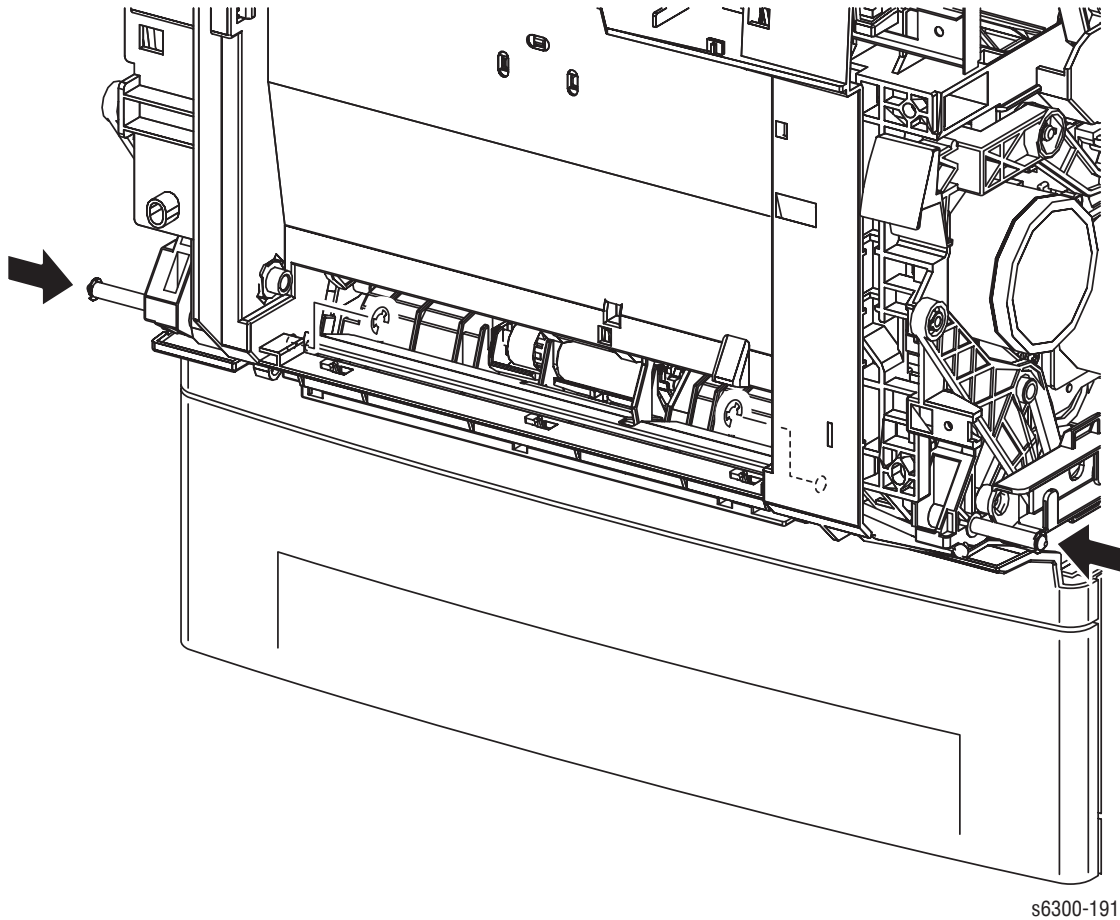

Replacement Note

Install the shorter of the two pivot pins into the left side of the printer.

20. Release the latch of the Chute Assembly Out.

21. Remove the Chute Assembly Out.

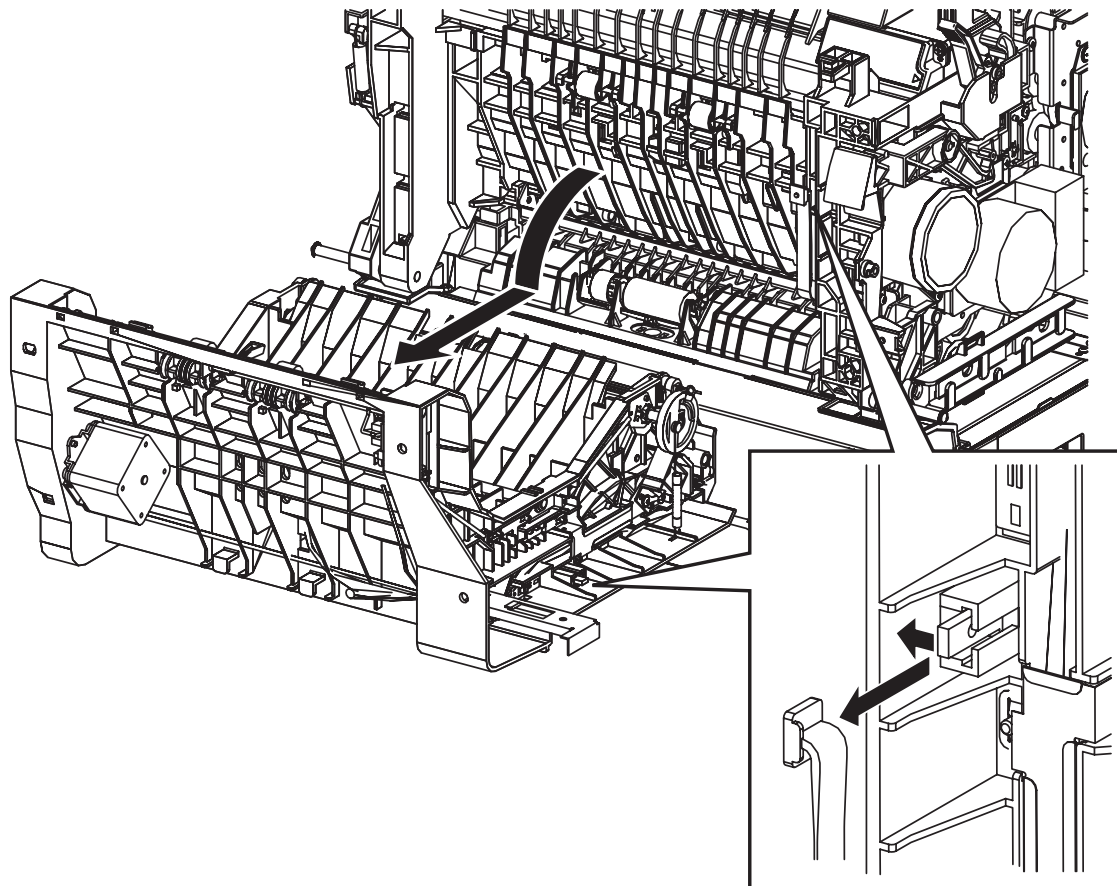

s6300-192

Xerographics

Fuser Fan (PL5.3.31)

1. Remove the Front Cover (page 8-10).
2. Disconnect the Fuser Fan connector (P/J483) and remove the harness from the harness guide.
3. Remove two screws (self-tapping, plastic 20 mm) that secure the Fuser Fan to the Chute Assembly Out.
4. Lift the Fuser Fan from the mounting.

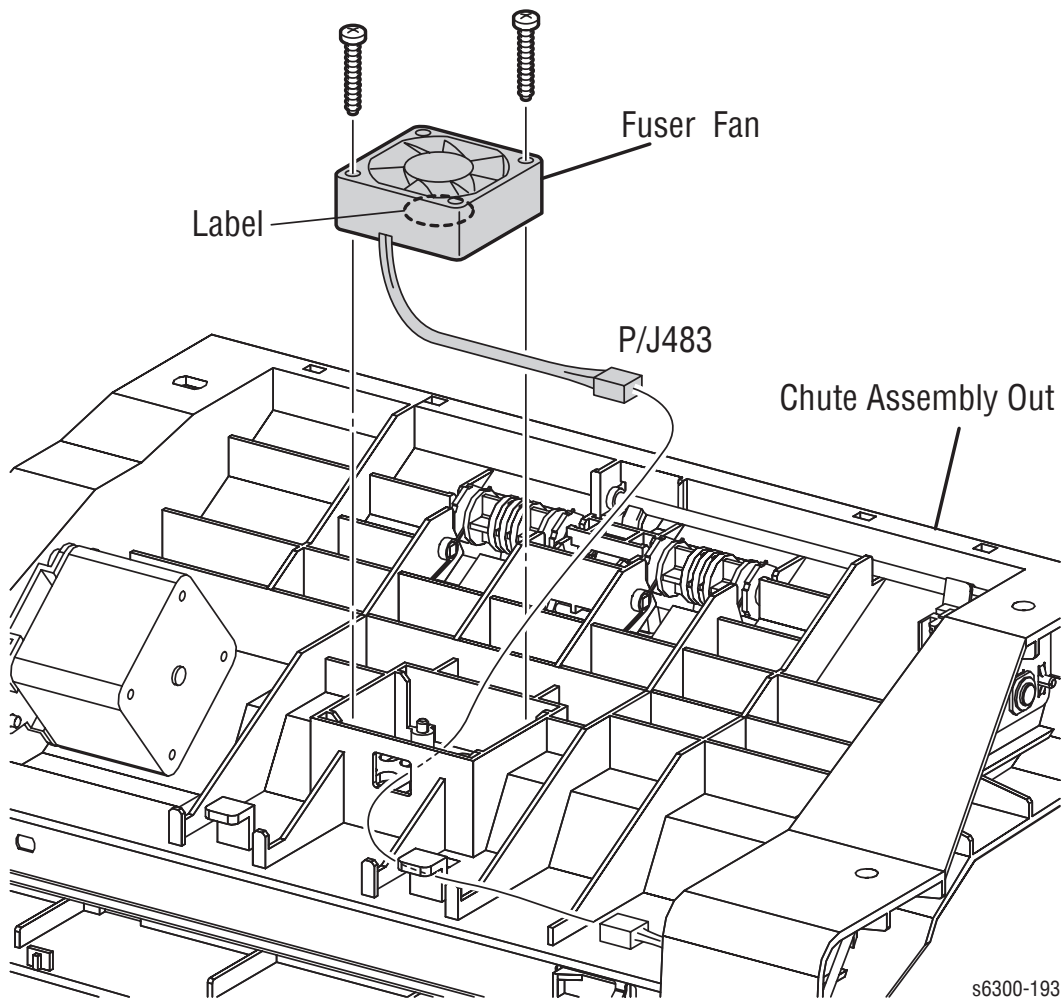

Replacement Note

Replace the fan with its label facing down.

Fuser (PL5.1.1)

Caution

Allow adequate time for the Fuser to cool before servicing the printer.

1. Open Door B.
2. Lift the amber gold levers at each end of the Fuser.
3. Grasp both handles and remove the Fuser.

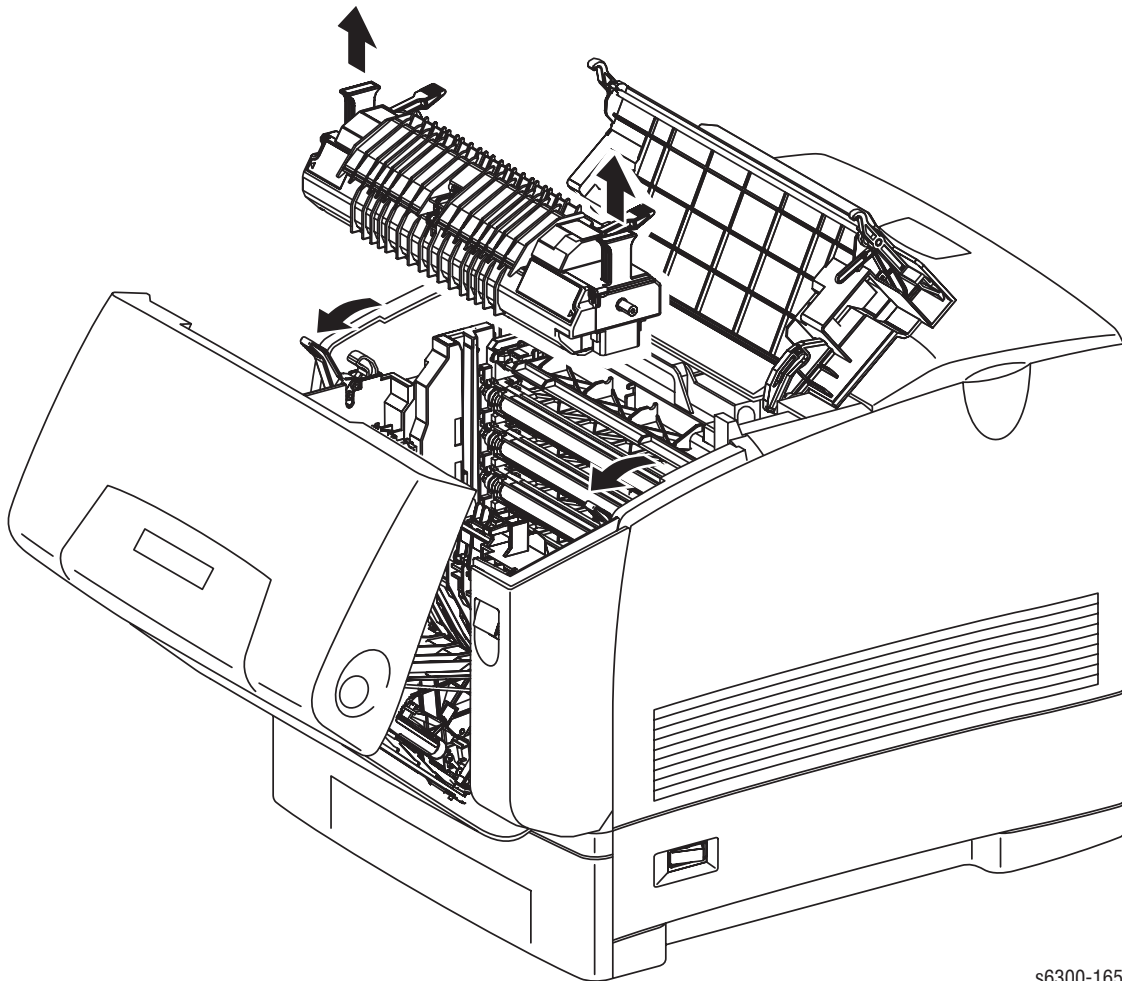

s6300-165

Replacement Note

After Fuser replacement, power cycle the printer to clear the Reseat Fuser error.

Fuser Exit Sensor Actuator (PL5.1.2)

Caution

Allow adequate time for the Fuser to cool before servicing the printer.

1. Open Door B.
2. Lift the levers at each end of the Fuser and remove the Fuser.
3. Remove the 2 hex-head screws (self-tapping, plastic 10 mm) that secure the Fuser fingers.
4. Remove the 2 hex-head screws (self-tapping, plastic 10 mm) that secure the Fuser Cover.
5. Remove the Fuser Exit Roller by unsnapping the shaft from the cover.

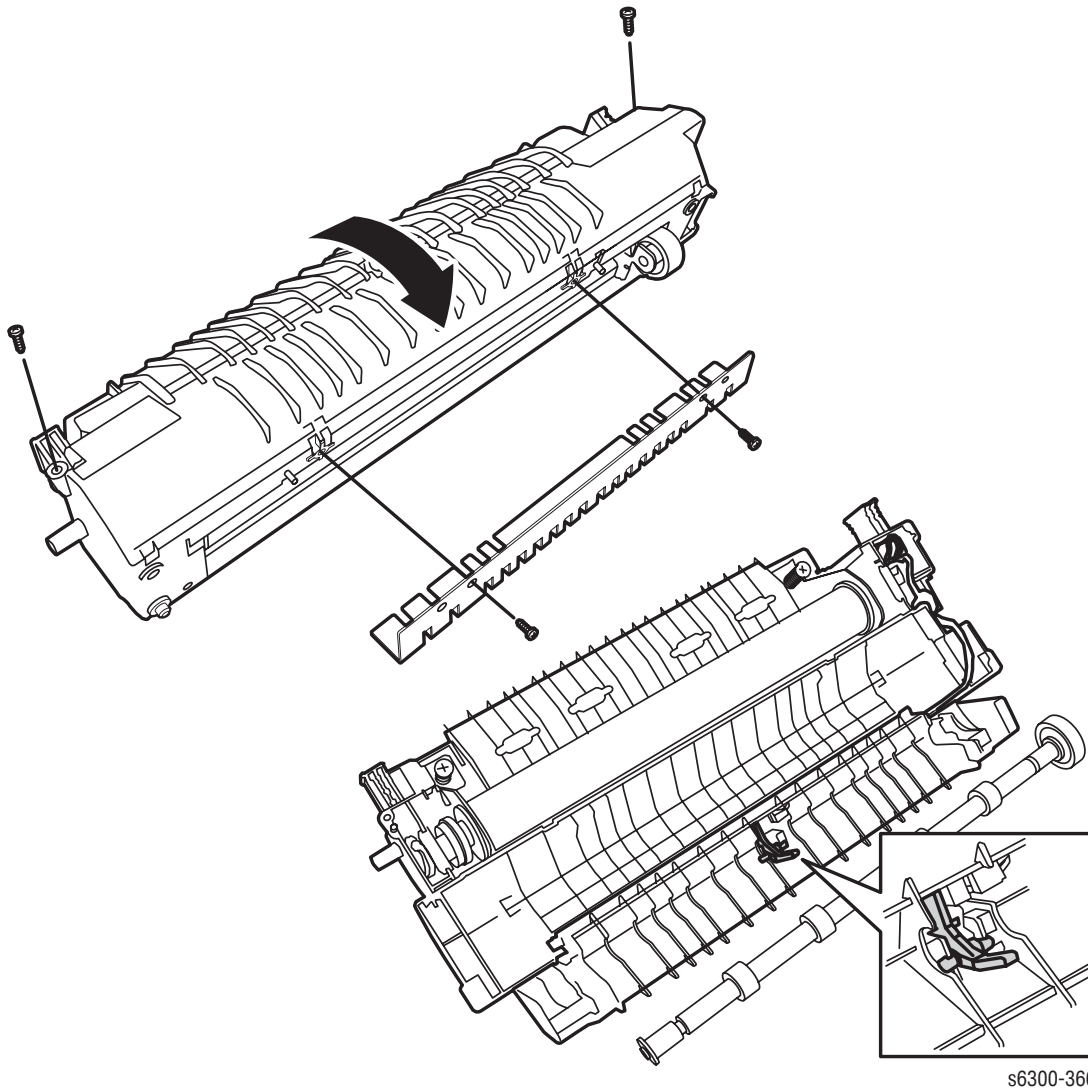

Replacement Note

Return the wiring to the recess provided and make sure the Spring is retained on the Fuser cover. After Fuser replacement, power cycle the printer.

Fuser Lock Lever (PL5.2.2)

Caution

Allow adequate time for the Fuser to cool before servicing the printer.

1. Open Door B.
2. Lift the locks at each end of the Fuser.
3. Grasp both handles and remove the Fuser.
4. From underneath the Lock, reach in with needle nose pliers or similar tool and release the Spring from the catch in the frame.

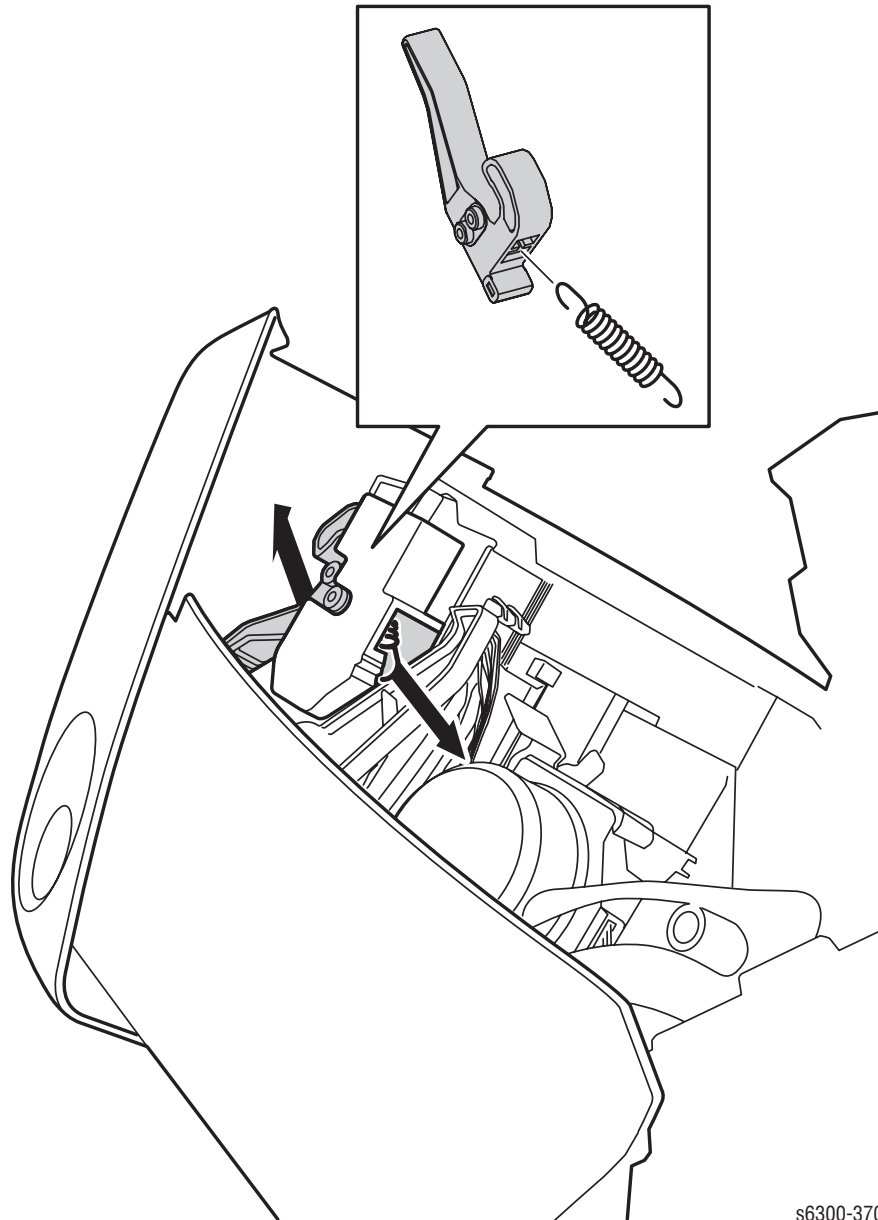

s6300-370

Replacement Note

Angle the Lock into the frame so the “heel” of the Lock slips under the partition in the Lock seat. After Fuser replacement, power cycle the printer.

Transfer Roller (PL5.1.4)

Caution

Allow adequate time for the Fuser to cool before servicing the printer.

1. Open Door A.
2. Push the levers at each side of the Transfer Roller inwards and rotate the Transfer Roller towards the rear of the printer to remove it.

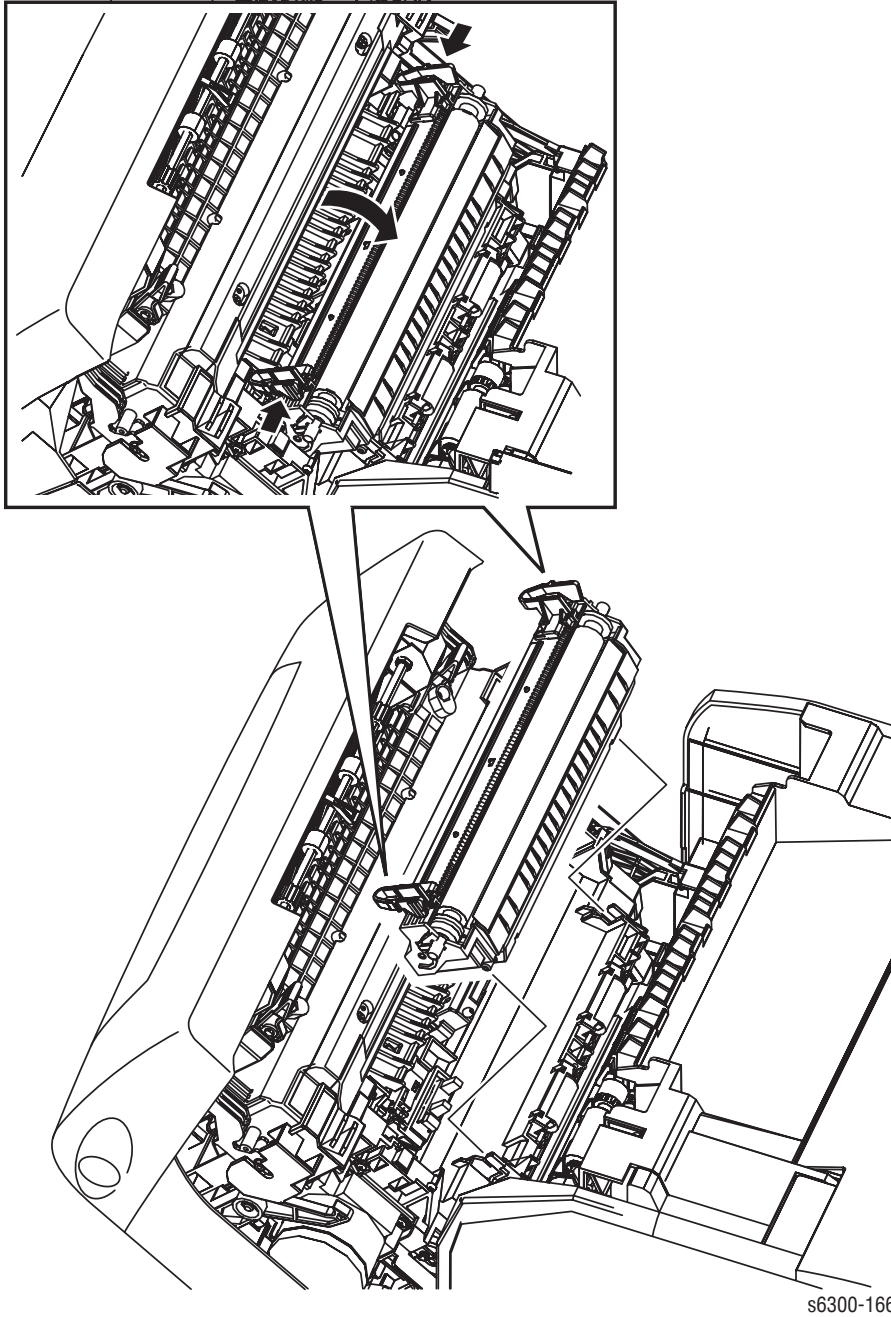

CTD (ADC) Sensor (PL5.2.19)

1. Open Door A.
2. Remove the Transfer Roller (page 8-70).

Note

The spring providing tension to the CTD (ADC) Sensor is not captive. Use care when removing the sensor to avoid the spring falling into the printer.

3. Pinch the 2 hooks that secure the CTD (Toner Density Control) (ADC) Sensor to the Chute Assembly In and remove it.
4. Unplug connector (P/J136) from the CTD (ADC) Sensor and release the harness from the cable guide.

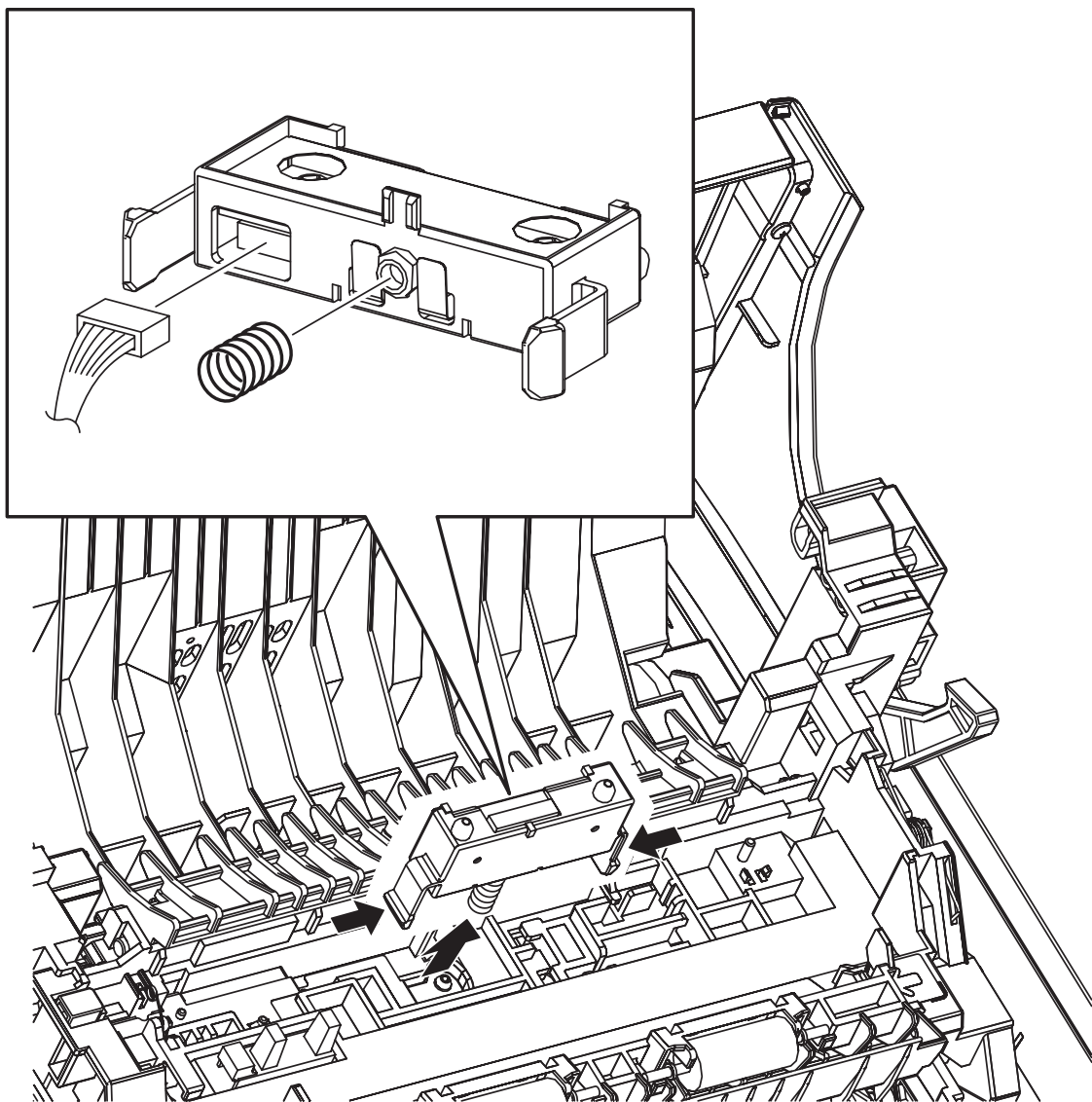

s6300-167

Toner Full Sensor (PL5.2.20)

1. Remove the Top Main Cover (page 8-8).
2. Remove the Left Side Cover (page 8-13).
3. Open Door B.
4. Remove the Fuser (page 8-67).
5. Release the hook to remove the Stopper Strap from Door B.

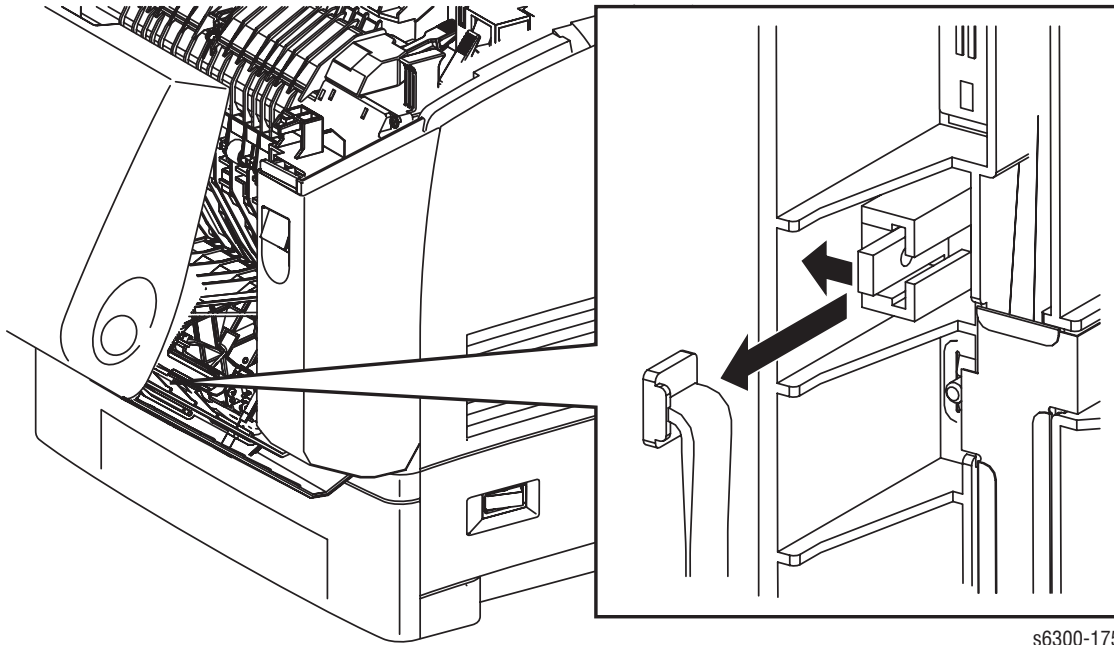

s6300-175

Caution

Hold Door B after releasing the link and spring to prevent it from falling open. Gently lower the door to the supporting surface.

8. Remove the Spring and Link on the left side of the frame.

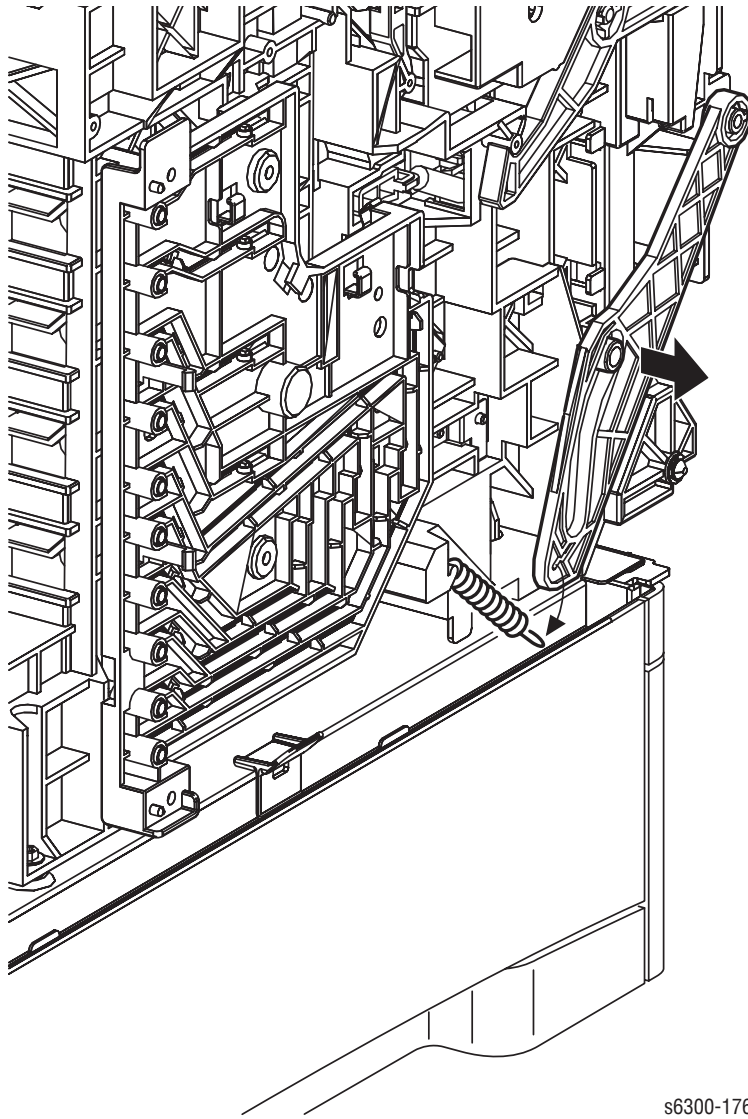

s6300-176

9. Gently lower Door B to a supporting surface.

10. Release the 3 hooks that secure the Toner Full Sensor to the Chute Assembly In.

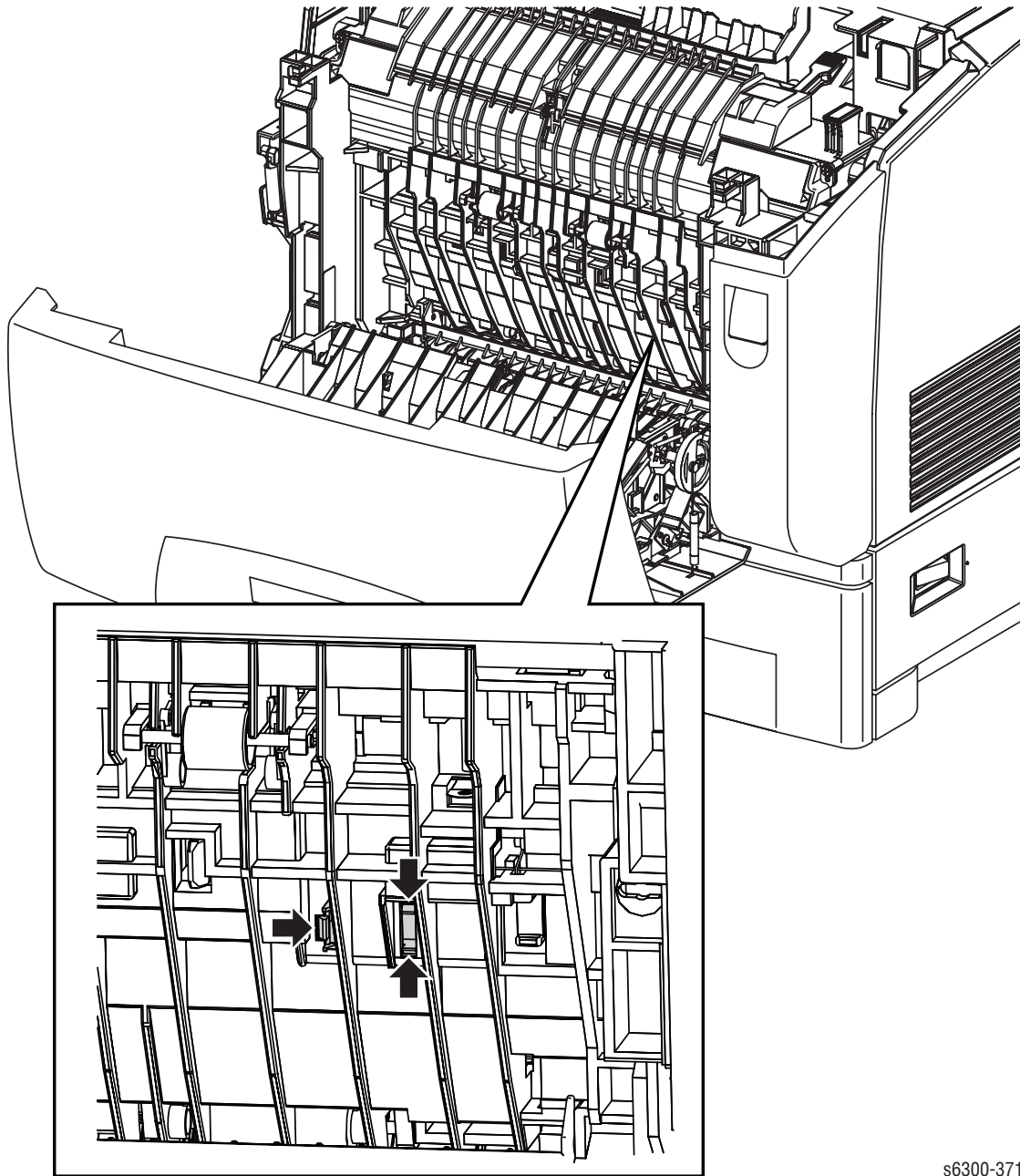

s6300-371

11. Open Door A.

12. Remove the Transfer Roller (page 8-70).

13. Unplug connector (P/J142) from the Toner Full Sensor and remove it.

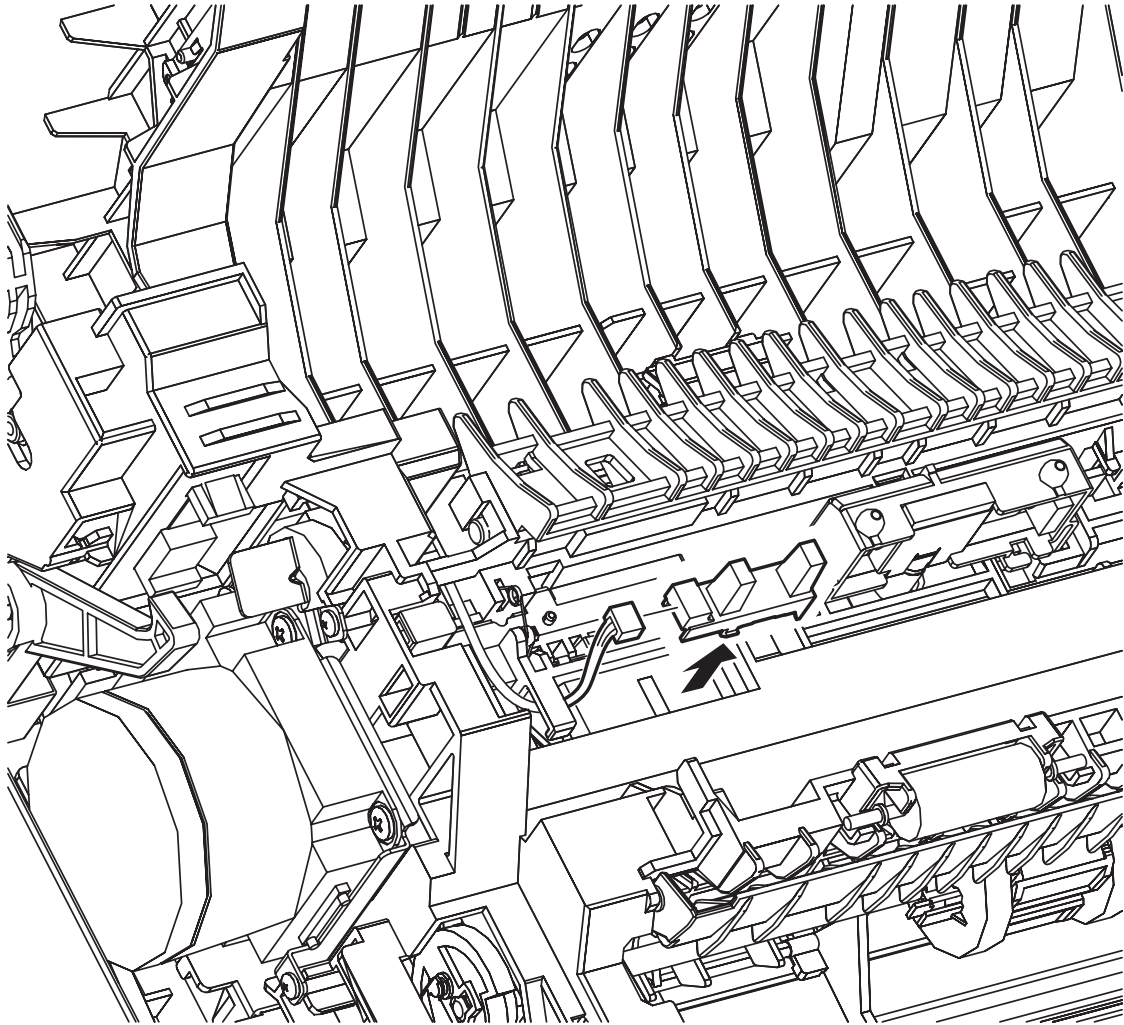

s6300-168

Laser Unit (PL6.1.2)

Access the upper Laser Unit screw by loosening the Toner Cartridge Holder Assembly and raising it.

Caution

Handle the Laser Unit carefully. Components within the Laser Unit are sensitive to shock and could be damaged.

1. Remove the Top Main Cover (page 8-8).
2. Remove the Right Side Cover (page 8-12).
3. Remove the Left Side Cover (page 8-13).
4. Remove the Rear Cover (page 8-16).
5. Remove the HVPS (page 8-109).
6. Remove the 2 wires from the harness guide on the CRUM Reader.
7. Disconnect (P/J342) from the CRUM Reader on the left side and remove the harness from the guide at the forward end of the CRUM Reader.
8. Disconnect the Interlock Switch harness from the LVPS.
9. Loosen the Toner Cartridge Holder Assembly (page 8-90).
10. Unplug connector (P/J151) that is connected to the Laser Unit.
11. Remove 2 screws (self-tapping, plastic 10 mm) that secure the Laser Unit at each side.
12. Hold the Laser Unit and raise the Toner Cartridge Holder Assembly enough to remove the Laser Unit upper screw (self-tapping, plastic 10 mm).
13. Move the Laser Unit rearward to remove it.

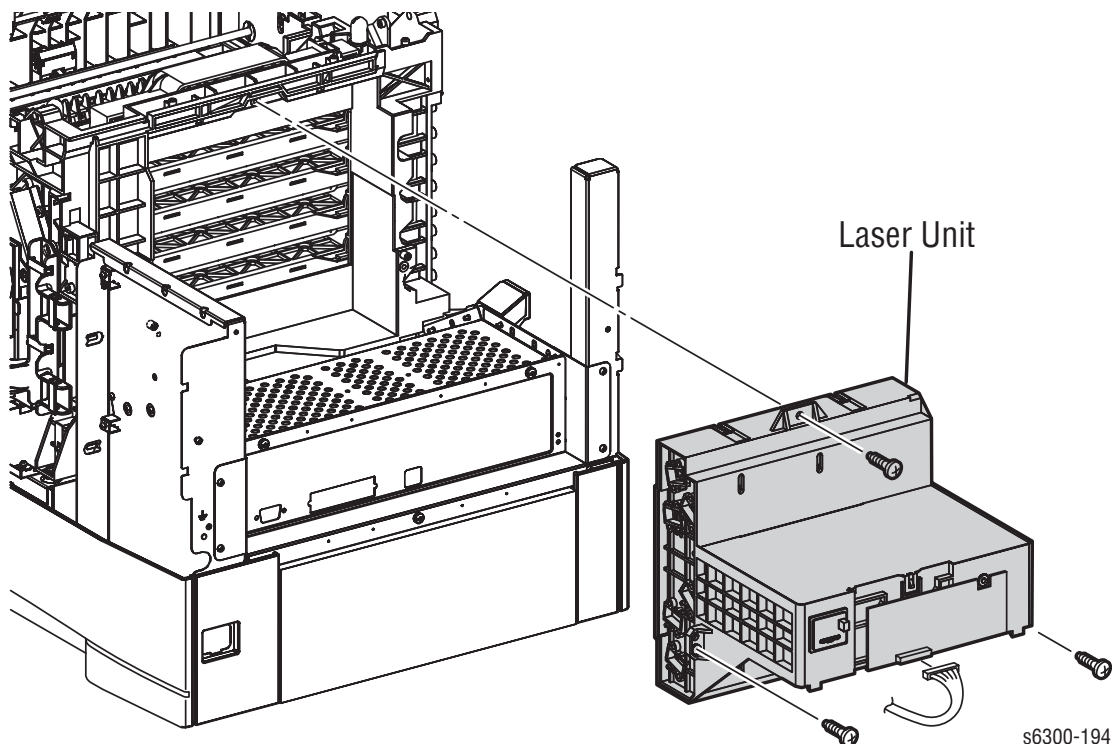

Housing Assembly Bias (PL6.1.7)

1. Remove the Top Main Cover (page 8-8).
2. Remove the Left Front Cover (page 8-18).
3. Remove the Left Side Cover (page 8-13).
4. Remove the HVPS (page 8-109).
5. Remove the 2 wires from the harness guide on the Housing Assembly Bias.
6. Remove the 4 screws (self-tapping, plastic 10 mm) that secure the Housing Assembly Bias to the printer and remove.

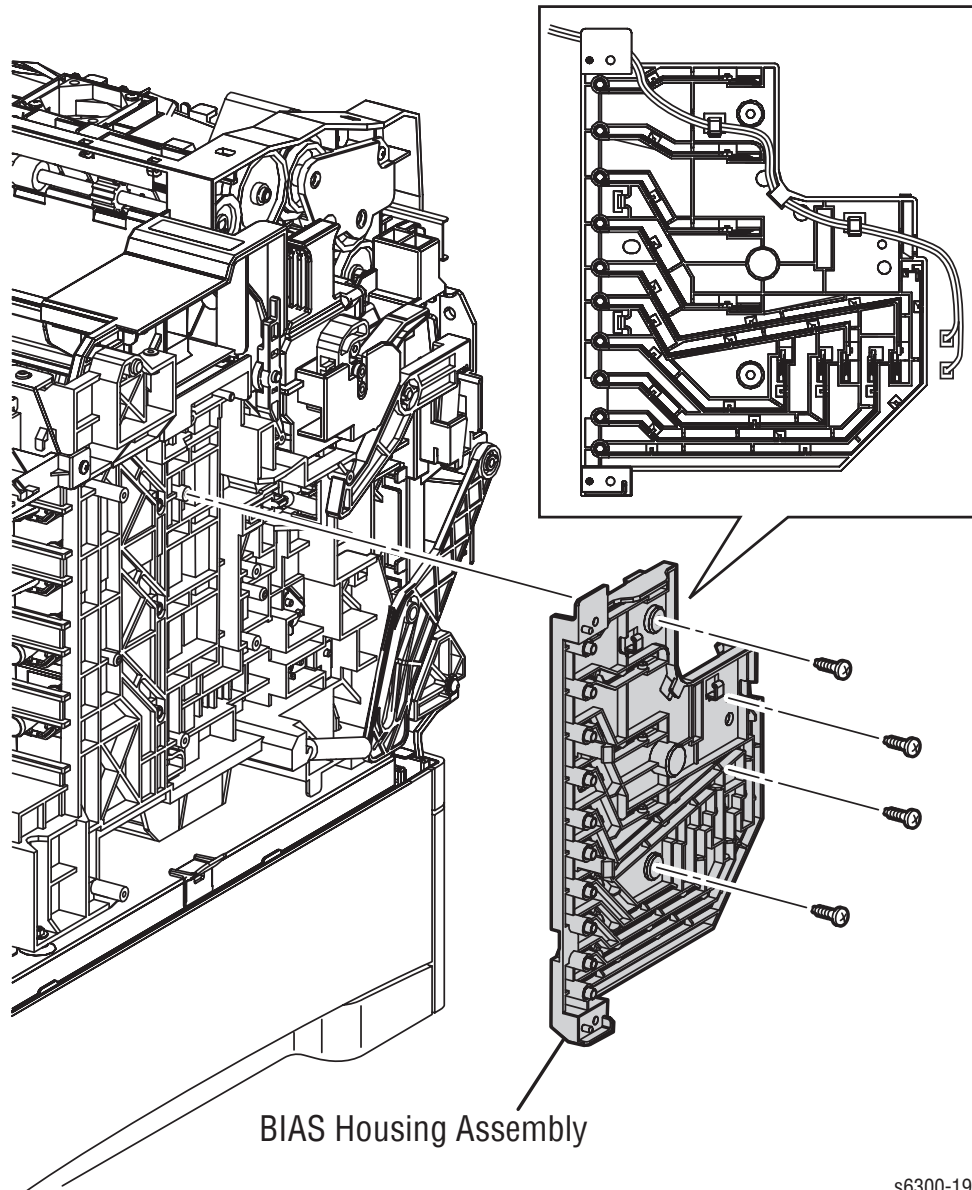

Replacement Note

The contact springs must protrude through to the inside of the printer.

Development

Developer Frame Assembly (PL7.1.1)

When removing the Developer Frame Assembly, cover the entire assembly with paper to help prevent toner from spilling onto your clothing. Also, be sure to store the removed Developer Frame Assembly on a flat surface with its handle upward.

Note

Toner will spill from the rear of the Developer Frame Assembly. Keep the assembly vertical to reduce the amount of Toner spillage. Following the repair, use an approved Type II Toner Vacuum to clean spilled toner from within the printer and around the work area.

1. Remove the Top Main Cover (page 8-8).
2. Remove the Left Side Cover (page 8-13).
3. Remove the HVPS (page 8-109).
4. Open Door A.
5. Open Door C.
6. Unplug the Imaging Unit CRUM connector (P/J484) at the top of the Developer Frame Assembly.
7. Release the hooks to disconnect the 4 toner nozzles attached to the Developer Frame Assembly.

Note

Check that the toner nozzle shutter at the end of each Auger Tube is closed. If the shutter is open; close it.

7. Lift the Developer Frame Assembly to remove.

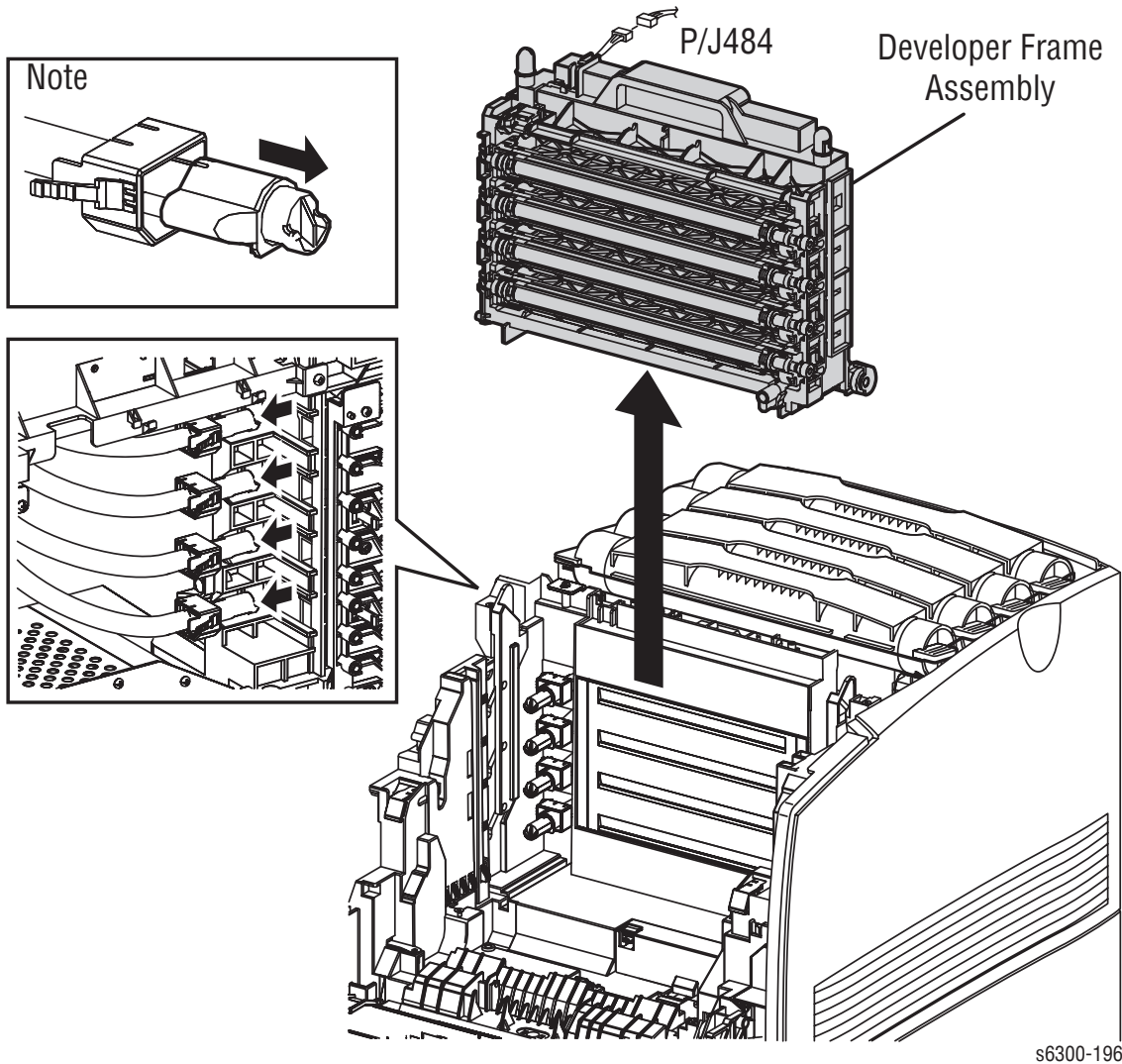

s6300-196

Replacement Note

Be sure to carefully match the colors of the 4 toner nozzles to the correct positions and that each nozzle is locked to the Developer Frame Assembly before replacing the covers. Also, reset the Developer Life Counters after replacing the Developer Assemblies.

CRUM Connector (PL7.1.4)

1. Open Door A.
2. Remove the Imaging Unit.
3. Disconnect (P/J710) from the CRUM connector and remove the harness from the guide.
4. Open the hook that secures the CRUM connector to its holder on the upper left side of Developer Frame Assembly and remove the connector.

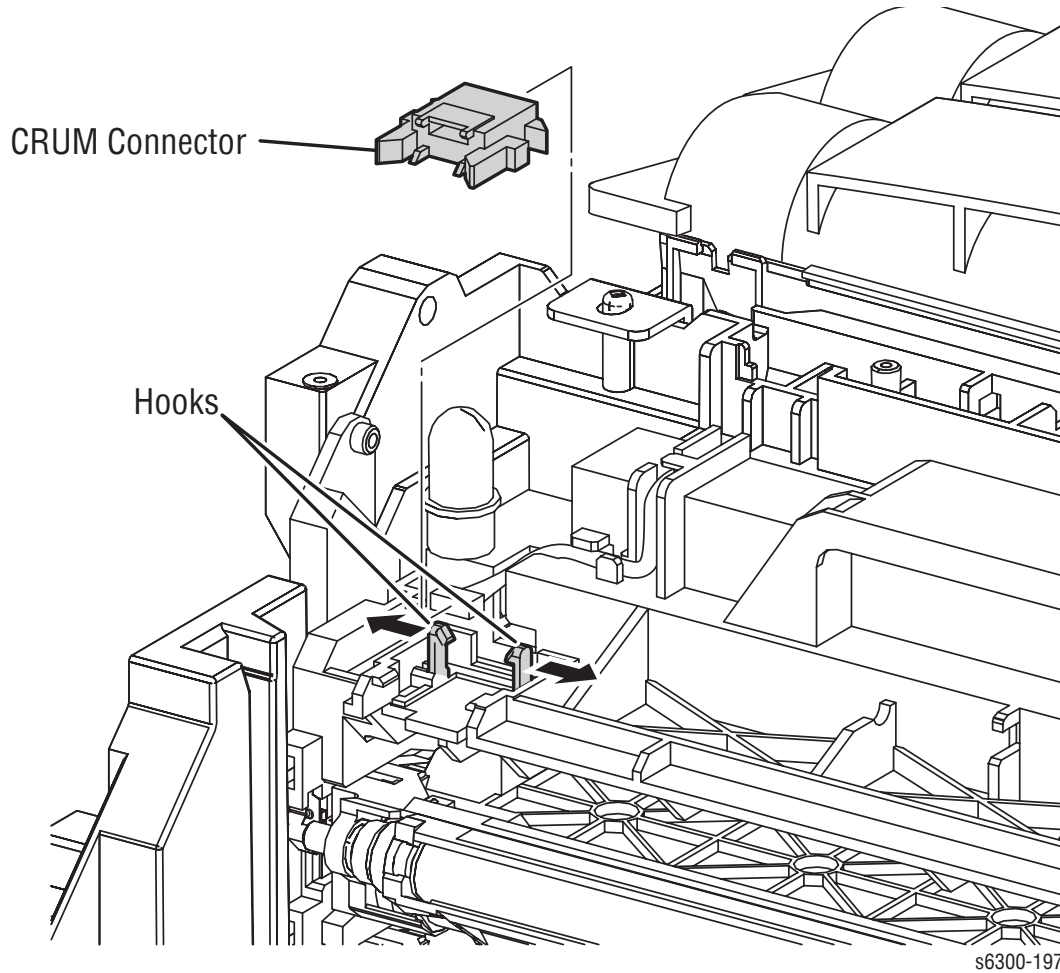

Replacement Note

Engage the two front connector guides, and then snap the connector into place.

Developer Assembly (PL7.1.17~20)

Since all four Developer Assemblies are removed in the same manner, use this procedure for any of the four colors.

Note

Toner will spill from the rear of the Developer Frame Assembly. Keep the assembly vertical to reduce the amount of Toner spillage. Prepare a location to replace the Developer Assemblies by covering a flat surface with paper or other material to capture Toner spilled during the replacement procedure. Following the repair, use an approved Type II Toner Vacuum to clean spilled toner from within the printer and around the work area.

1. Remove the Top Main Cover (page 8-8).
2. Remove the Left Front Cover (page 8-18).
3. Remove the Left Side Cover (page 8-13).
4. Remove the HVPS (page 8-109).
5. Remove the Developer Frame Assembly (page 8-78).
6. Open the replacement Developer Assembly packaging and transfer the shipping plugs and roller cover from the new assembly to the old. Use the plugs, cover, and packaging to repackage the old part for return.

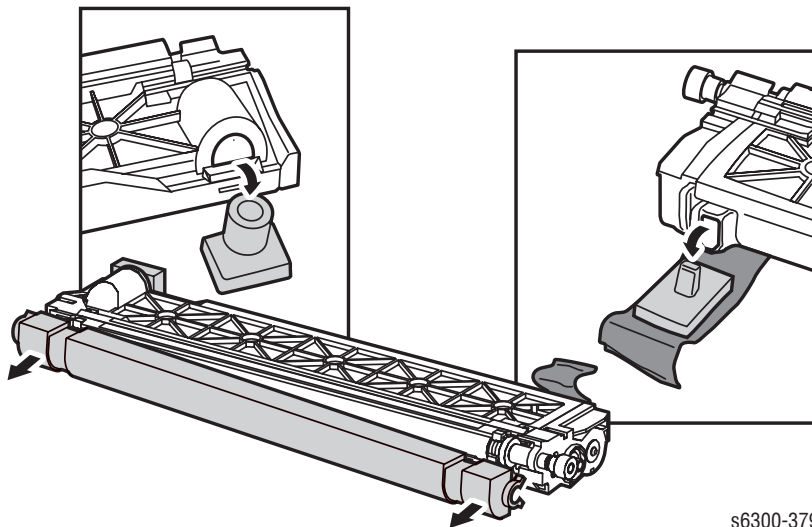

s6300-379

7. Release the left and right stoppers located on the Developer Frame Assembly and remove the Developer Assembly.

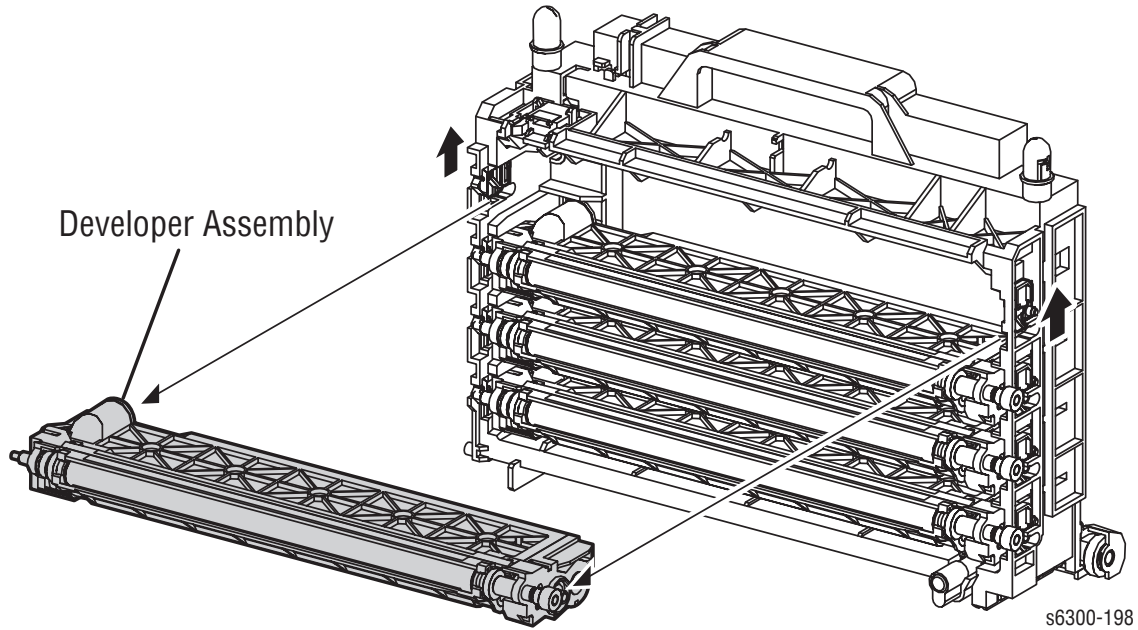

Replacement Note

Inspect each Developer Assembly slot prior to installing the replacement to ensure the left and right tracking spring (PL7.1.13) is securely attached to the Developer Frame Assembly. There should be 2 tracking springs per Developer Assembly.

Be sure to carefully match the colors of the 4 toner nozzles to the correct positions and that each nozzle is locked to the Developer Frame Assembly before replacing the covers.

CRUM Reader (PL7.2.12)

1. Remove the Top Main Cover (page 8-8).

Note

Control Toner spillage by replacing the cartridges after removing the cover.

2. Remove the Right Side Cover (page 8-12).
3. Remove the Left Side Cover (page 8-13).
4. Remove the Rear Cover (page 8-16).
5. Remove the 2 wires (red) from the harness guides on the CRUM Reader.
6. Remove the screw (metal, 6 mm) and the screw (self-tapping, plastic 10 mm) that secure each end of the CRUM Reader to the frame.
7. Remove the 4 screws (self-tapping, plastic 10 mm) that secure the Toner Cartridge Holders to the CRUM Reader.
8. Release the boss on each Toner Cartridge Holder from the CRUM Reader.

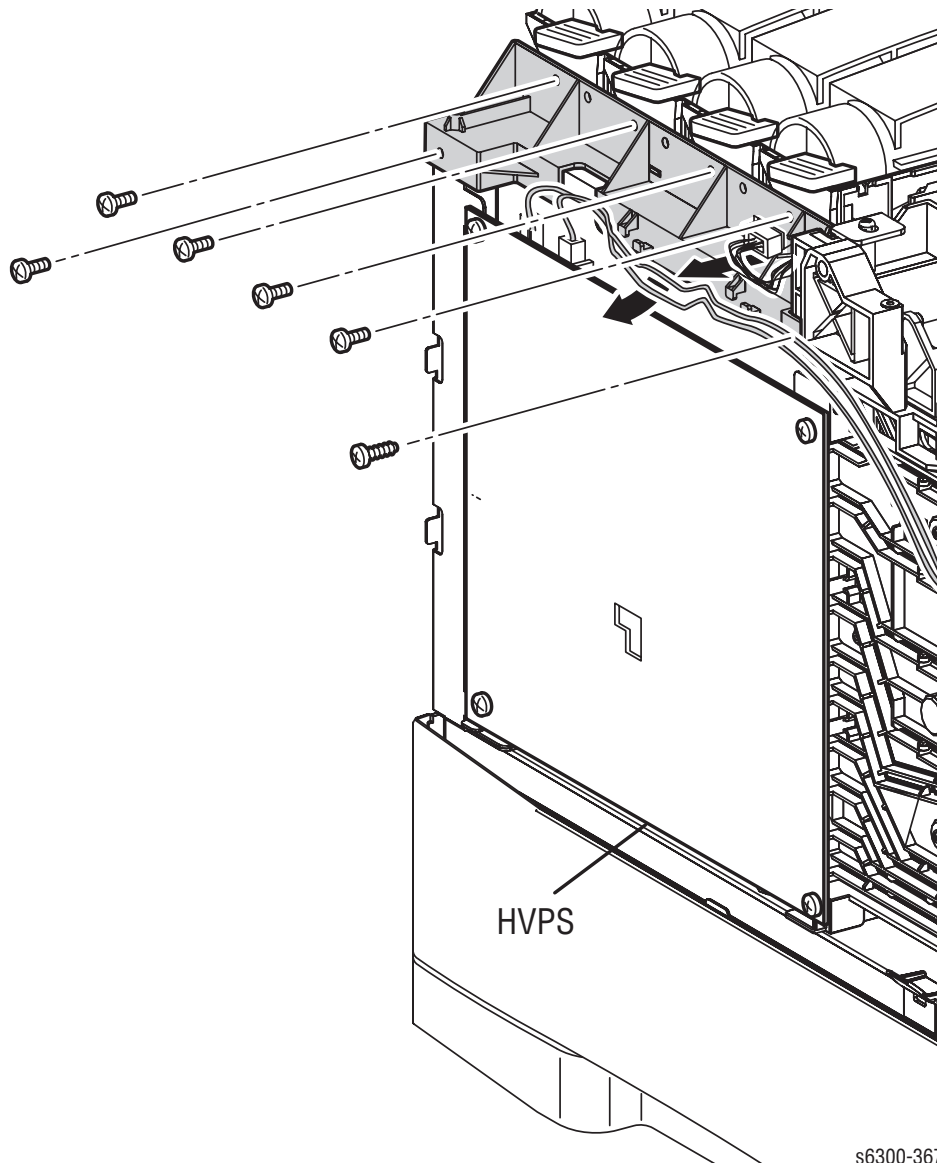

s6300-367

9. From the rear of the printer, unplug the CRUM Reader connector (P/J3411).
10. Disconnect (P/J342) from the CRUM Reader on the left side and remove the harness from the guide at the forward end of the CRUM Reader.

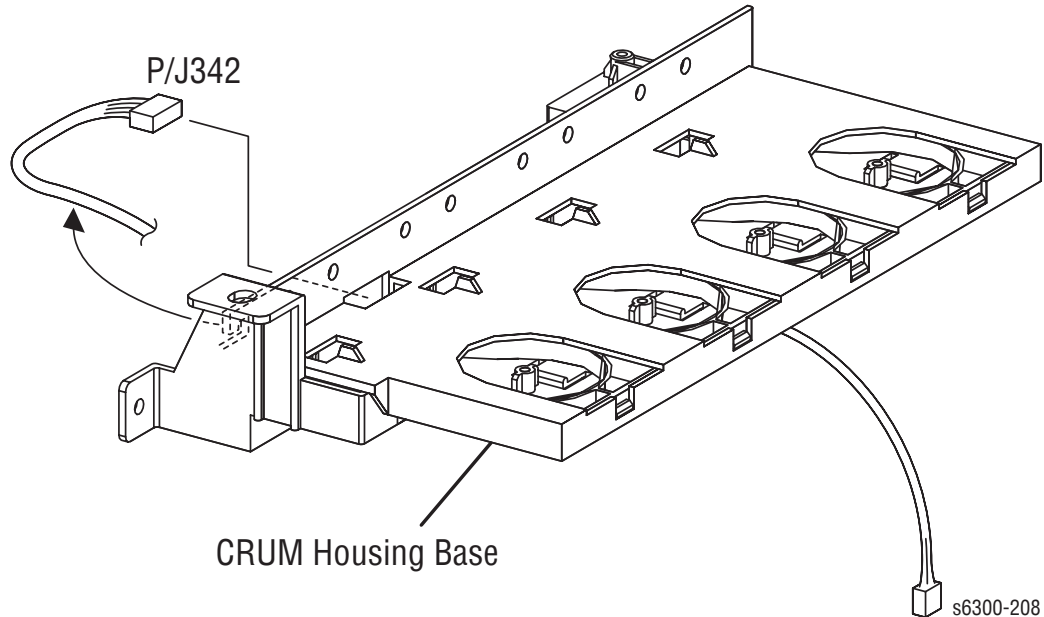

11. Separate the CRUM Reader from the Toner Cartridge Holders by grasping all four Toner Cartridge locks and tipping the CRUM Reader towards the center to release the hooks on the underside of the holders from the CRUM Reader.

Replacement Note

Support the CRUM Reader from underneath and slide it into position. Position each cartridge holder, working from Yellow to Black and slide the CRUM to the right to lock the cartridge holders in place and engage the bosses.

Toner Cartridge Holder (PL7.2.1~4)

The procedure for removal of the Toner Cartridge Holder is the same for all colors.

Note

To control Toner spillage, do not disconnect the Auger Tube from the Developer Frame Assembly unless absolutely necessary to perform the repair. Remove the HVPS to access the Auger Tube connections.

1. Remove the CRUM Reader (page 8-83).

Note

With the CRUM Reader removed, any of the four Toner Cartridge Holders are available for removal and servicing.

2. Disconnect the appropriate Toner Motor and No Toner Sensor connections from the holder being removed.
3. Remove the harness from the clamp mounted directly above the motor.
4. Remove the screw (metal, 6 mm) that secures the end of the Toner Cartridge Holder to the Toner Cartridge Holder Assembly.
5. Release the T-shaped hook near the Toner Motor to release the Toner Cartridge Holder from the assembly.
6. Disconnect the Auger Tube.

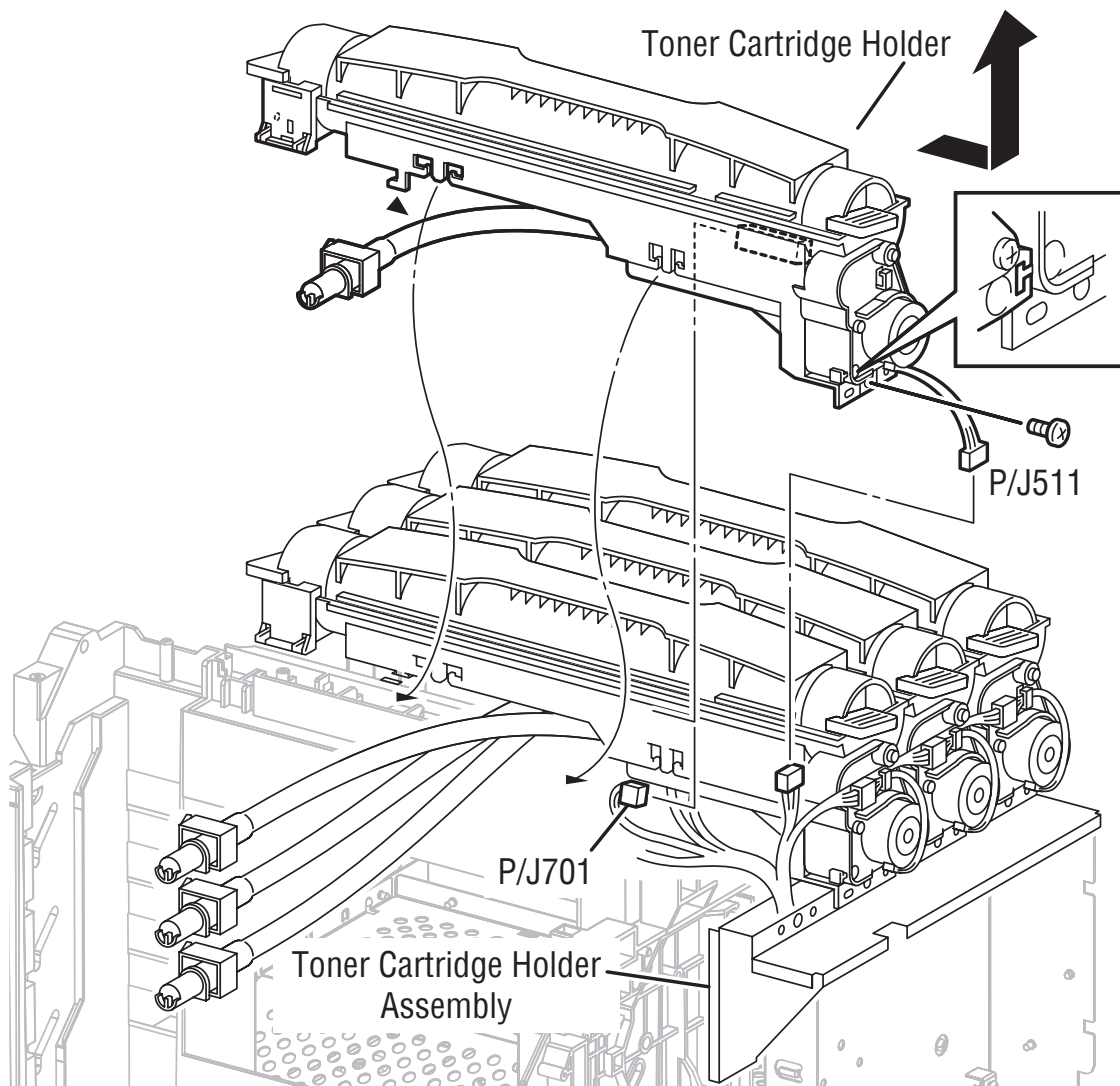

s6300-201

Replacement Note

When replacing a holder located between two other colors, spread the installed holders slightly as you insert the replacement. Lock all four Toner Cartridge Holders into the CRUM Reader.

To refill the new Auger Tube, run the Service Diagnostics Toner Motor test for the appropriate color continuously for a period of no more than 90 seconds.

No Toner Sensor (Y), (M), and (C) (PL7.2.5)

The procedure for removing the No Toner Sensor from the (Y), (M), or (C) Toner Cartridge Holder is essentially the same. The procedure described below applies to all three.

Note

To control Toner spillage, do not disconnect the Auger Tube from the Developer Frame Assembly unless absolutely necessary to perform the repair. Remove the HVPS to access the Auger Tube connections.

1. Remove the CRUM Reader (page 8-83).
2. Remove the Toner Cartridge Holder (page 8-85).
3. Spread the 4 hooks on the Toner Cartridge Holder that secure the No Toner Sensor.
4. Unplug the connector from the No Toner Sensor and remove the sensor.

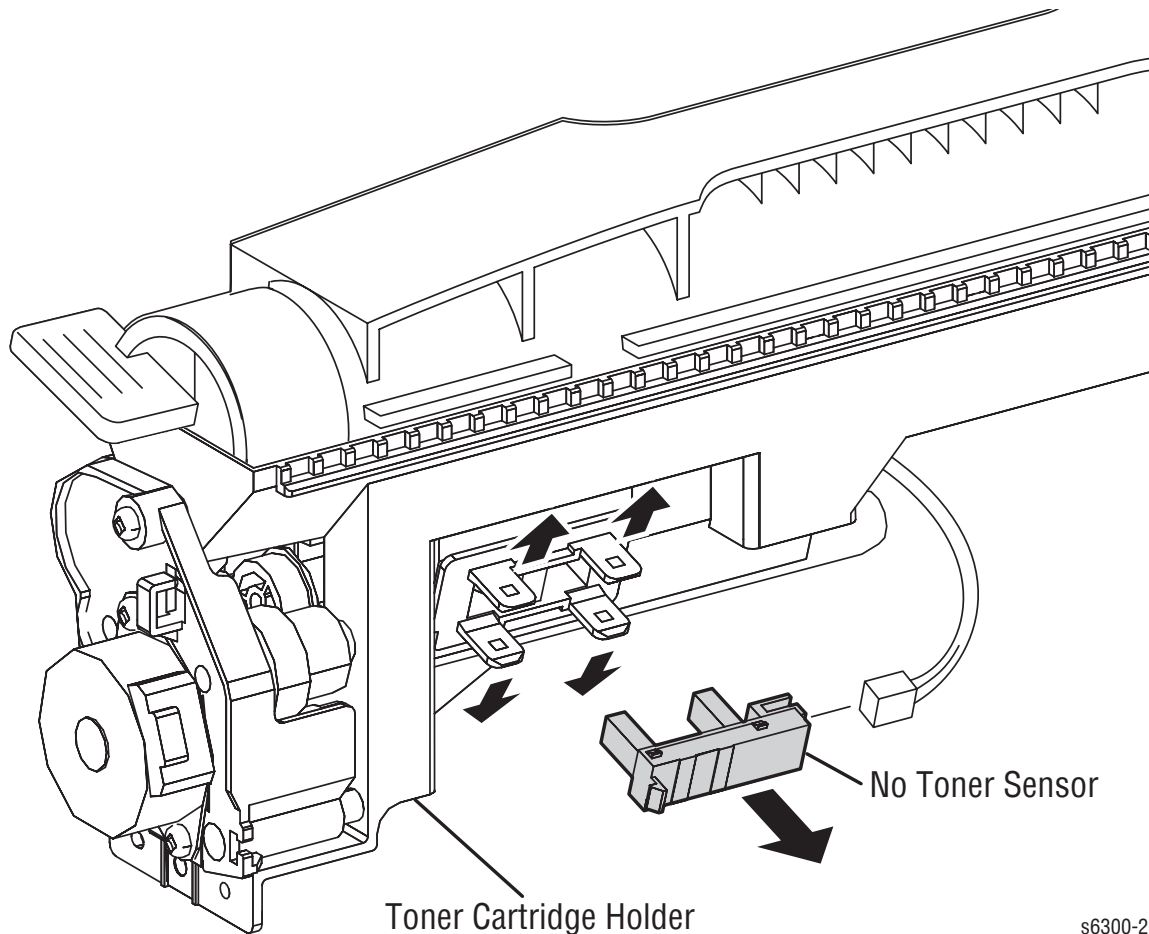

Replacement Note

Lock all four Toner Cartridge Holders into the CRUM Reader.

No Toner Sensor (K) (PL7.2.5)

1. Remove the Top Main Cover (page 8-8).
2. Remove the Right Side Cover (page 8-12).
3. Remove the Left Side Cover (page 8-13).
4. Remove the Rear Cover (page 8-16).
5. Unplug connector (P/J704) from the No Toner Sensor.
6. Spread the 4 hooks on the Toner Cartridge Holder that secure the sensor.
7. Remove the No Toner Sensor from the Toner Cartridge Holder.

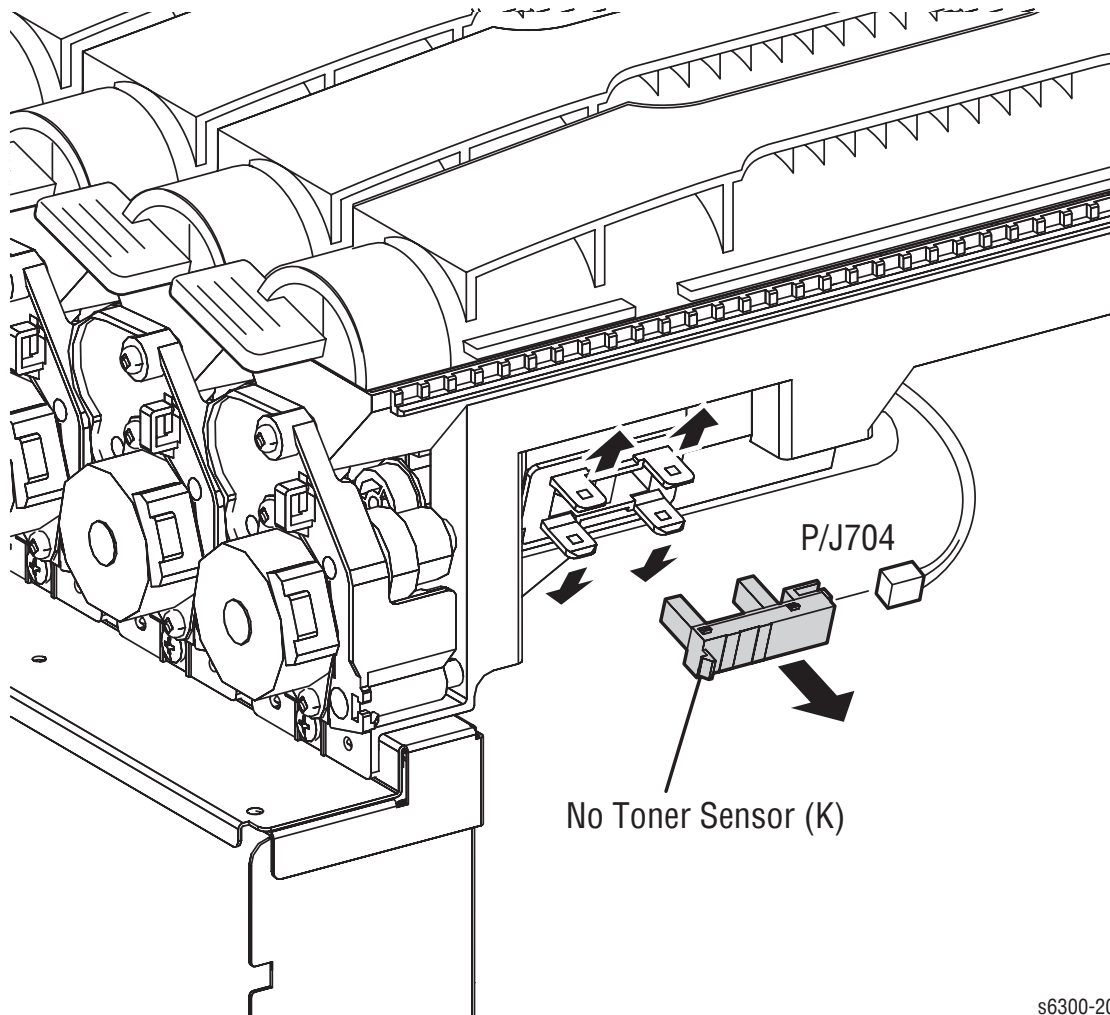

s6300-206

Toner CTG-IN Actuator and Switch Bracket (PL7.2.7)

The following procedure applies to all four Toner CTG-IN Actuators and brackets.

Note

To control Toner spillage, do not disconnect the Auger Tube from the Developer Frame Assembly unless absolutely necessary to perform the repair. Remove the HVPS to access the Auger Tube connections. Use care when handling the holder to avoid Toner leaking from the tube.

1. Remove the CRUM Reader (page 8-83).
2. Unlock and remove the Toner Cartridge.
3. Remove the Toner Cartridge Holder (page 8-85).
4. Release the 2 hooks that secure the bracket to the Toner Cartridge Holder with a miniature screwdriver or similar tool and remove the bracket.
5. Release the bracket hooks and remove the Actuator.

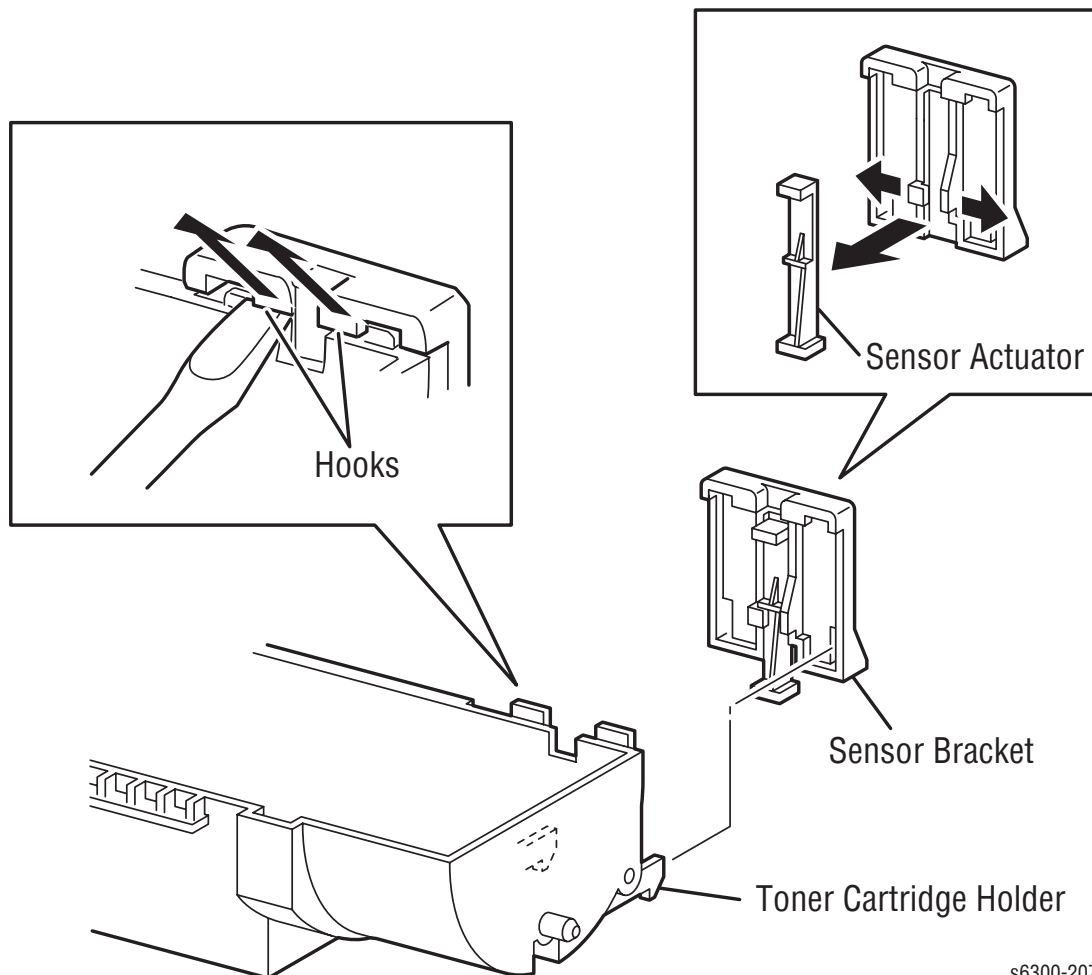

Replacement Note

Lock all four Toner Cartridge Holders into the CRUM Reader.

Toner Cartridge Holder Assembly

Complete removal of the Toner Cartridge Holder Assembly is not required to access the upper most Laser Unit screw. Use the following procedure to loosen the assembly and lift it approximately 0.5 inch it to allow access to the Laser Unit screw without disconnecting the Auger Tubes or removing the Toner Cartridges.

Warning

Be sure to clean up any residual toner on the Toner Cartridge Holder Assembly with a dedicated toner vacuum cleaner. Do not clean up toner with a general-purpose vacuum cleaner to avoid the risk of explosion by igniting the fine powder. As an additional precaution, be sure to attach a ground cable to the toner vacuum cleaner to discharge static electricity.

Caution

Take care not to allow toner dust to adhere to the photo sensors located on the Toner Cartridge Holder Assembly. Toner adhering to the photo sensors reduces their efficiency and could cause erroneous errors.

1. Remove the Top Main Cover (page 8-8).

Note

To control Toner spillage, after removing the Top Main Cover, replace the Toner Cartridges and lock them into place.

2. Remove the Right Side Cover (page 8-12).
3. Remove the Left Side Cover (page 8-13).
4. Remove the Rear Cover (page 8-16).
5. Remove the 2 wires (red) from the harness guide on the CRUM Reader.

6. Remove the Interlock Switch from the clamp on the Toner Cartridge Holder Assembly.

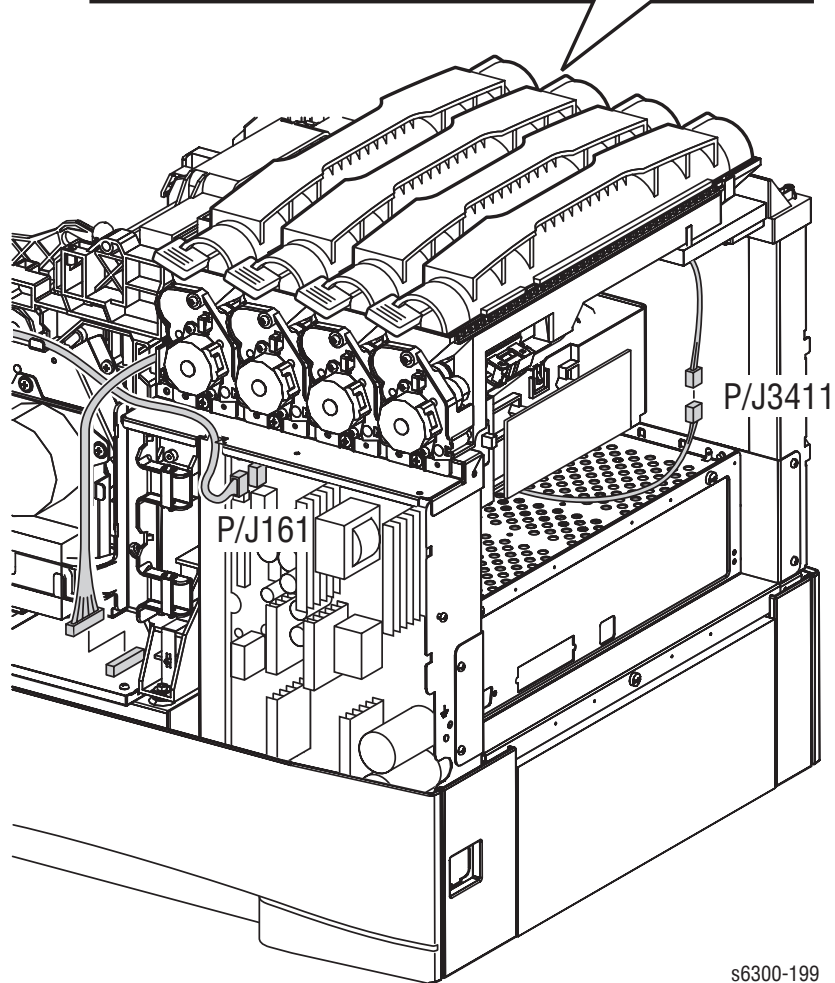
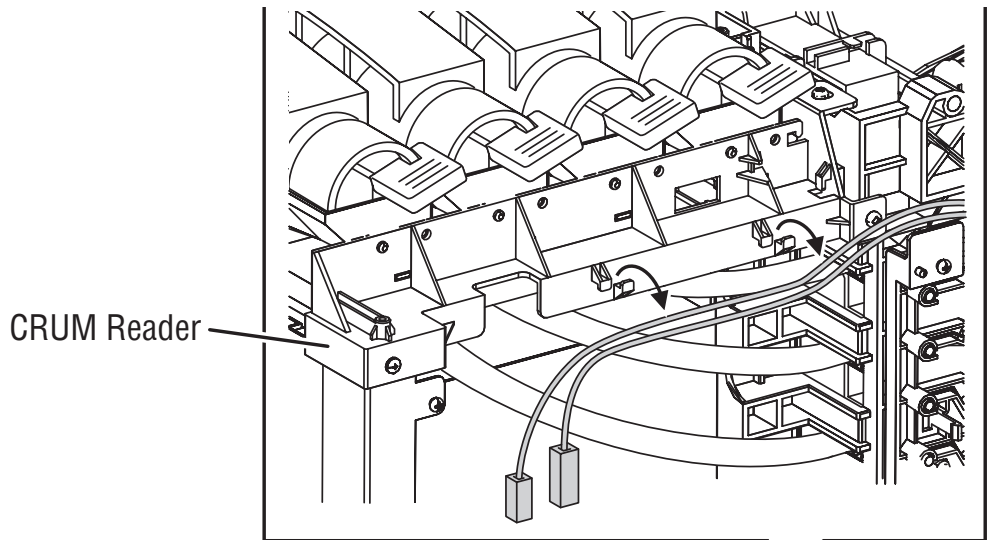

7. Remove the 4 screws (2 metal, 6 mm) and (2 self-tapping, plastic 10mm) that secure the Toner Cartridge Holder Assembly.
8. Gently the Toner Cartridge Holder Assembly and the CRUM Reader to provide access to the Laser Unit screw.

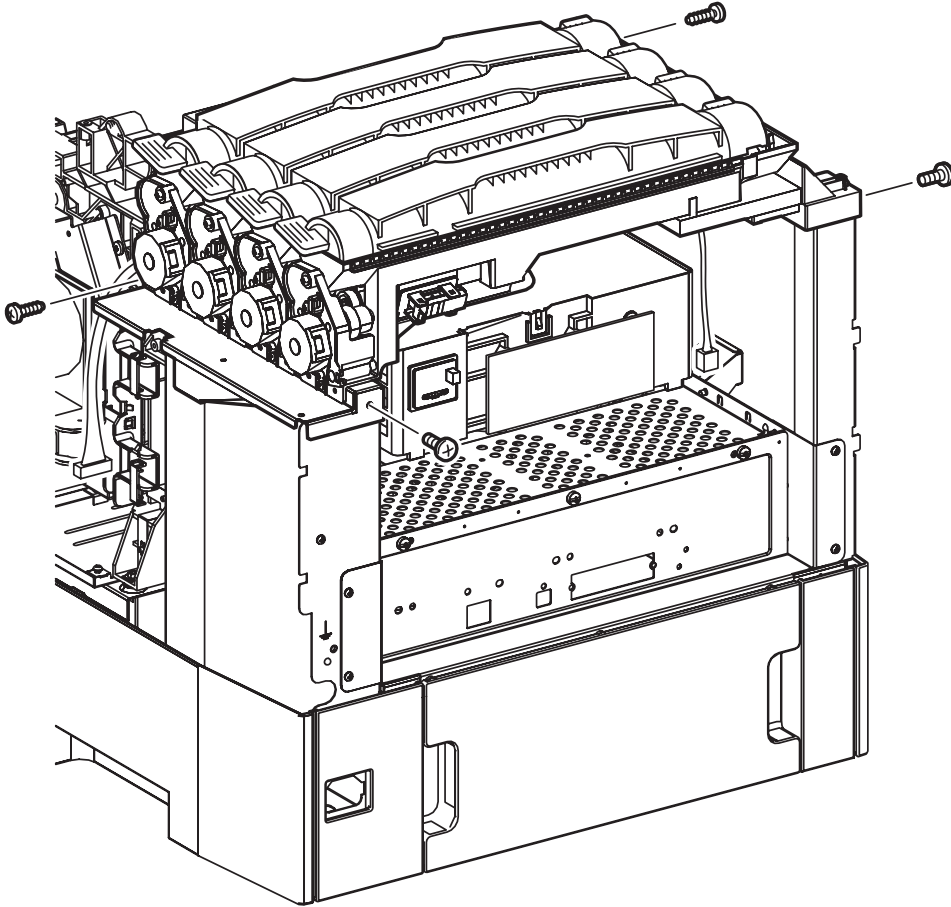

s6300-200

Drive

Developer Drive Assembly (PL8.1.1)

1. Remove the Top Main Cover (page 8-8).
2. Remove the Right Side Cover (page 8-12).
3. Remove the four Harness Guide Clamps from the Rear Harness Guide and remove the harnesses.
4. Release the clamps on the Developer Drive Assembly and remove the Interlock Switch harness.
5. Remove the 2 screws (silver, tap 10 mm) that secure the Rear Harness Guide and move the guide to the rear to release the front hook from the Developer Drive Assembly.
6. Remove the Rear Harness Guide.

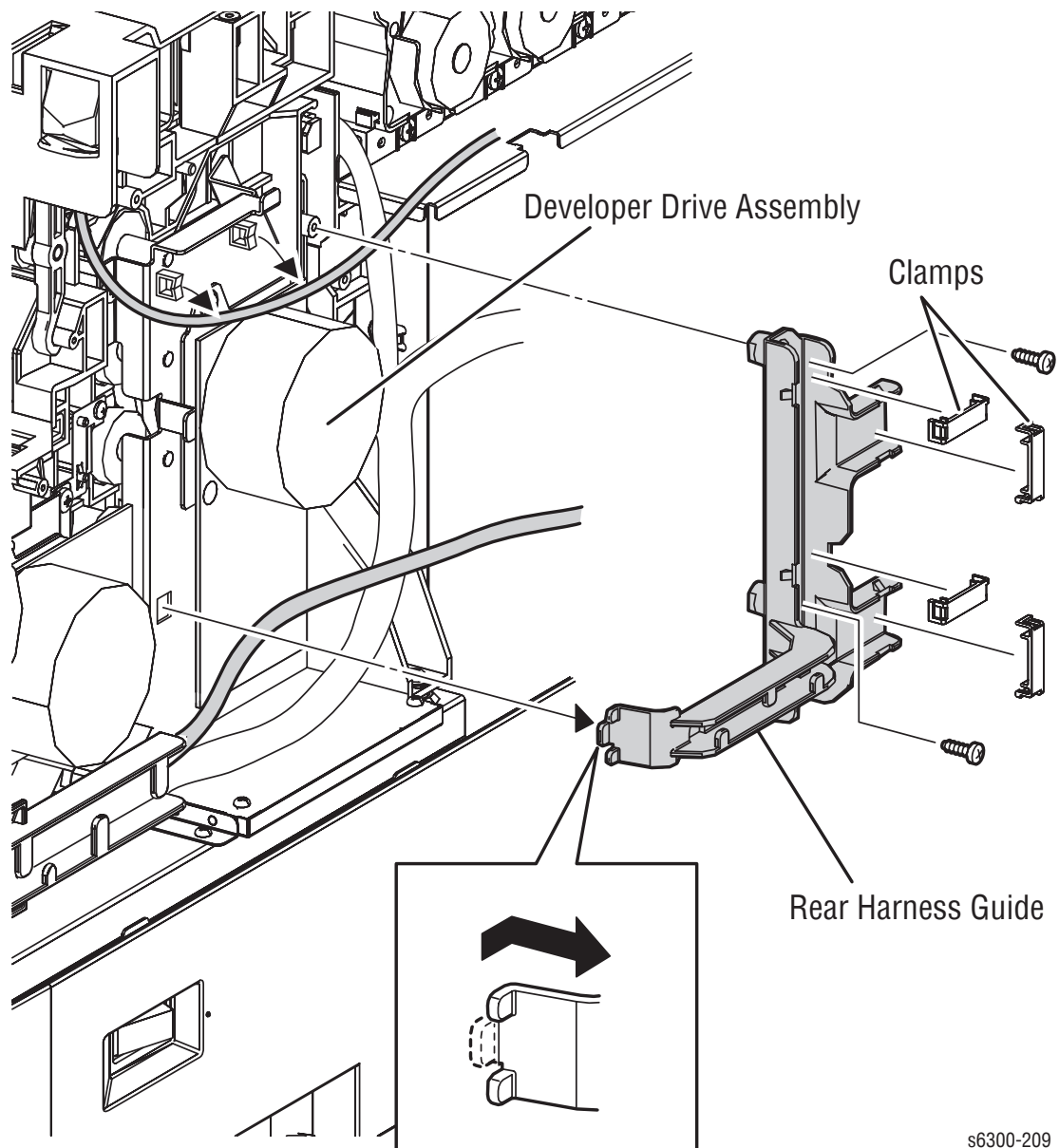

s6300-209

7. Unplug connector (P/J491) from the Developer Drive Assembly.
8. Remove the 3 screws (silver, tap 10 mm) that secure the Developer Drive Assembly to the printer and remove.

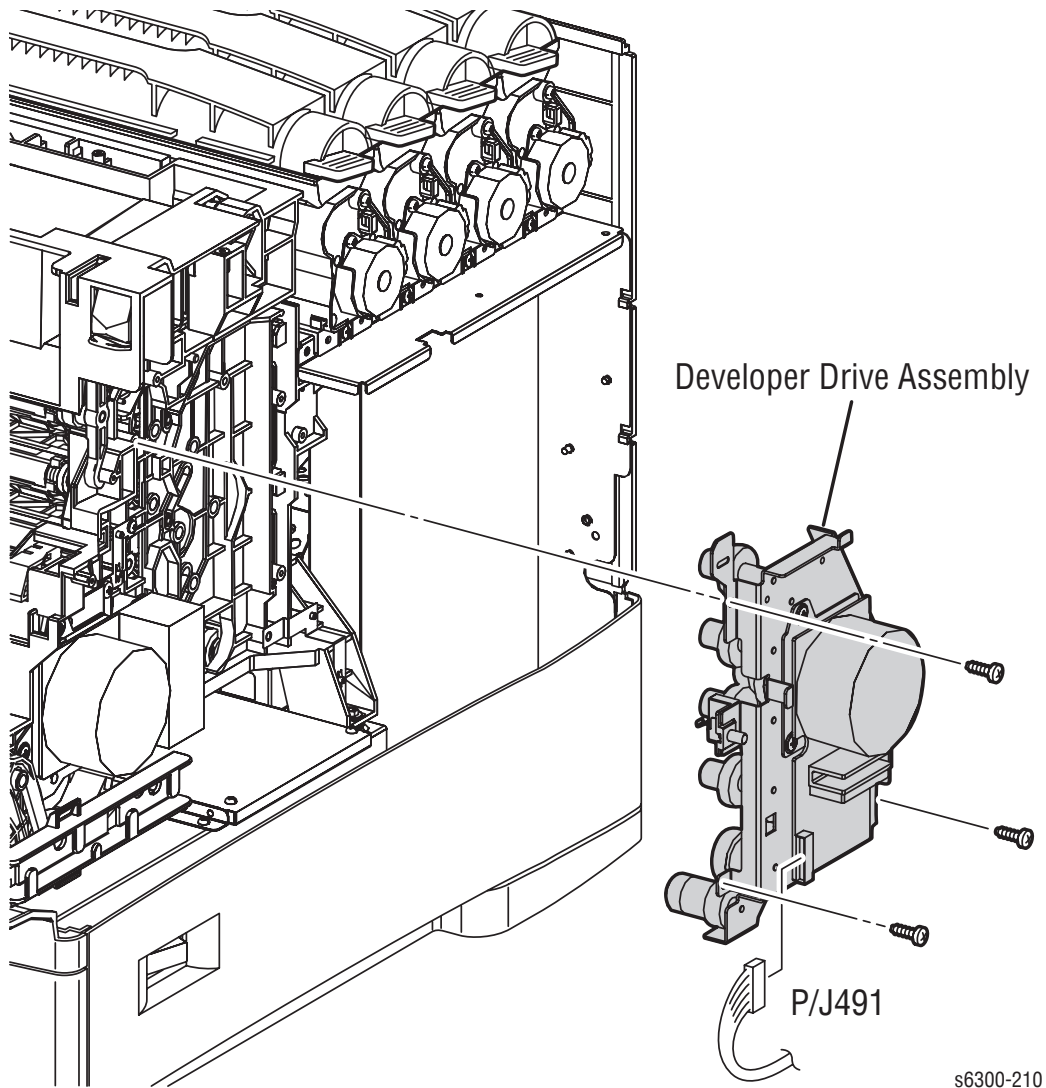

Replacement Note

When replacing the motor, rotate the motor housing to engage the Developer Drive gears. Verify that the gears are engaged before installing the mounting screws.

Main Drive Assembly (PL8.1.2)

1. Remove the Top Main Cover (page 8-8).
2. Remove the Right Side Cover (page 8-12).
3. Disconnect the Main Drive Assembly connector (P/J481).
4. Remove the 4 screws (silver, tap 10 mm) that secure the Main Drive Assembly to the printer.
5. Remove the Main Drive Assembly.

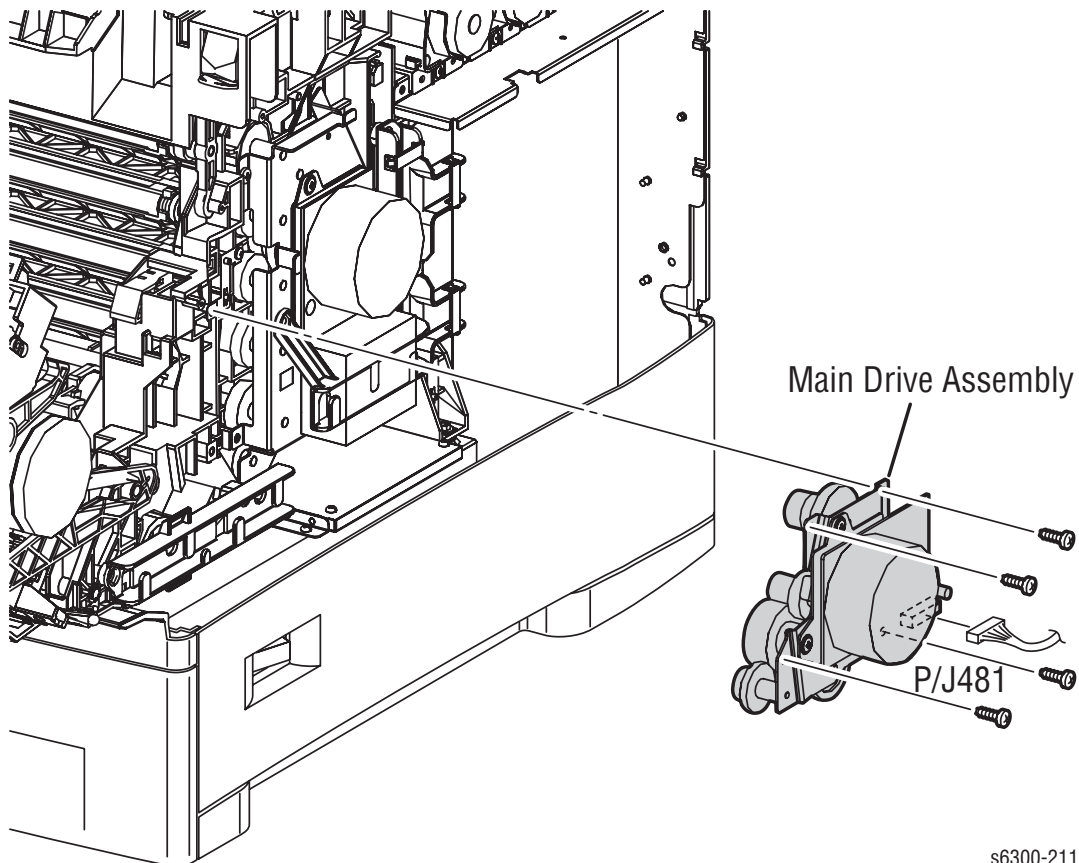

s6300-211

Replacement Note

When replacing the motor, rotate the motor housing to engage the Main Drive gears. Verify that the gears are engaged before installing the mounting screws.

Fuser Drive Assembly (PL5.2.25)

1. Remove the Top Main Cover (page 8-8).
2. Remove the Right Front Cover (page 8-17).
3. Remove the Right Side Cover (page 8-12).
4. Remove the Link Arm Spring and Link Arm.

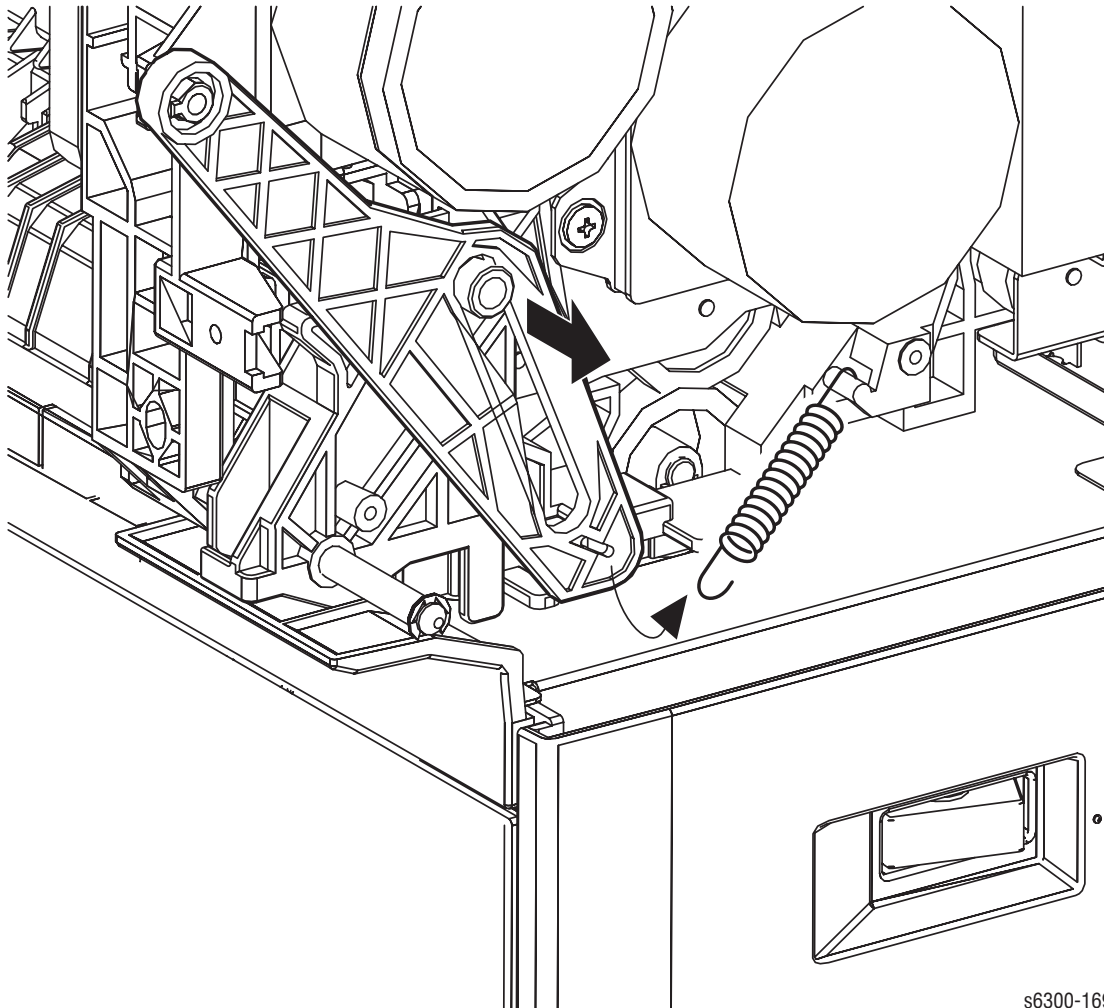

s6300-169

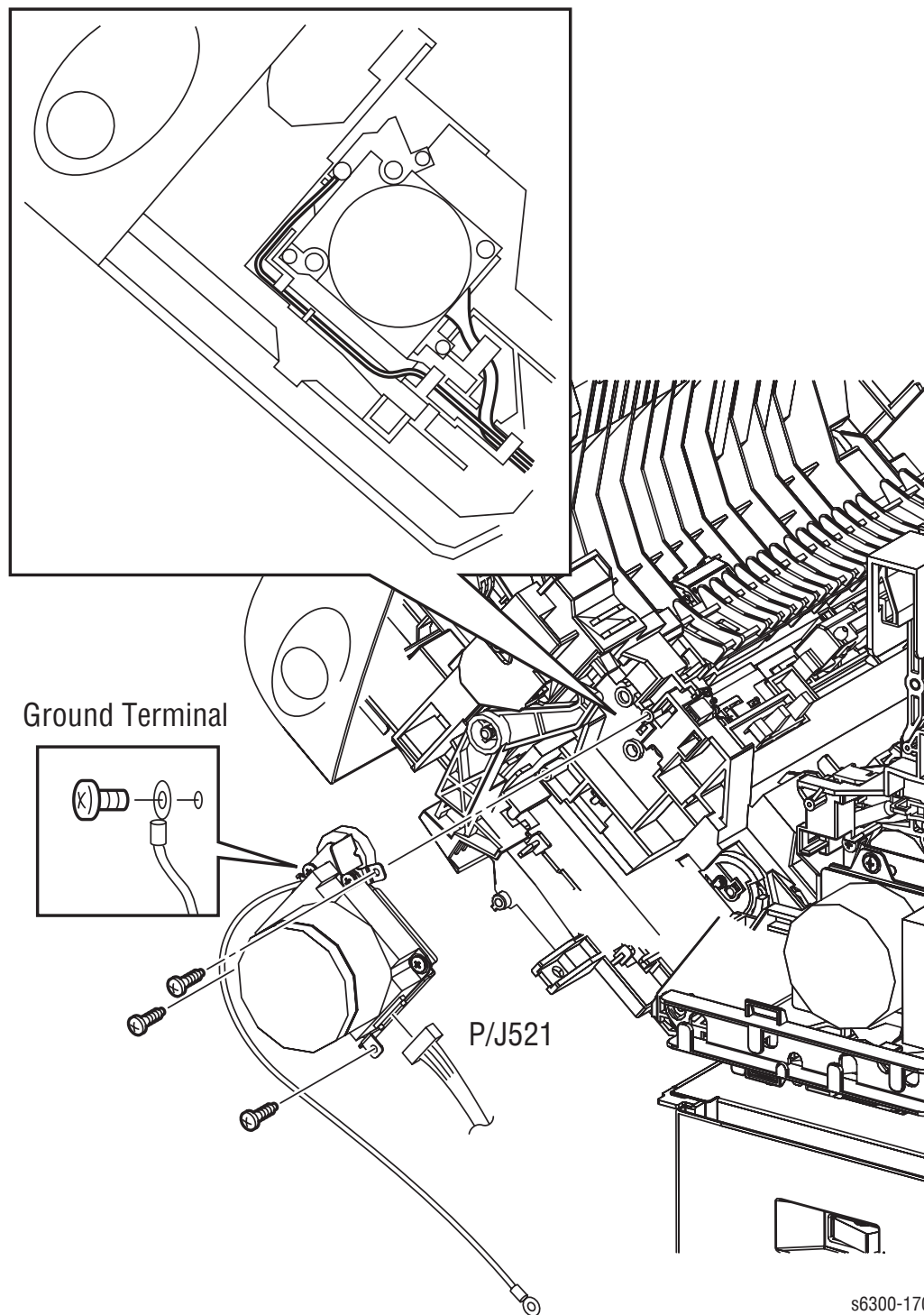

- 6.** Remove the 3 screws (self-tapping, plastic 10 mm) that secure the Fuser Drive Assembly to the Chute Assembly In.
- 7.** Pull the Fuser Drive Assembly away from the frame to release the gears.
- 8.** Remove the screw (silver, 5 mm) that secures the ground wire to the Fuser Drive Assembly.
- 9.** Unplug connector (P/J521) and remove the Fuser Drive Assembly.

Electrical

Image Processor Board (PL9.1.3)

1. Remove the Tray Rear Cover (page 8-22).
2. Remove the 6 screws that secure the Rear Panel to the printer and pull to remove.

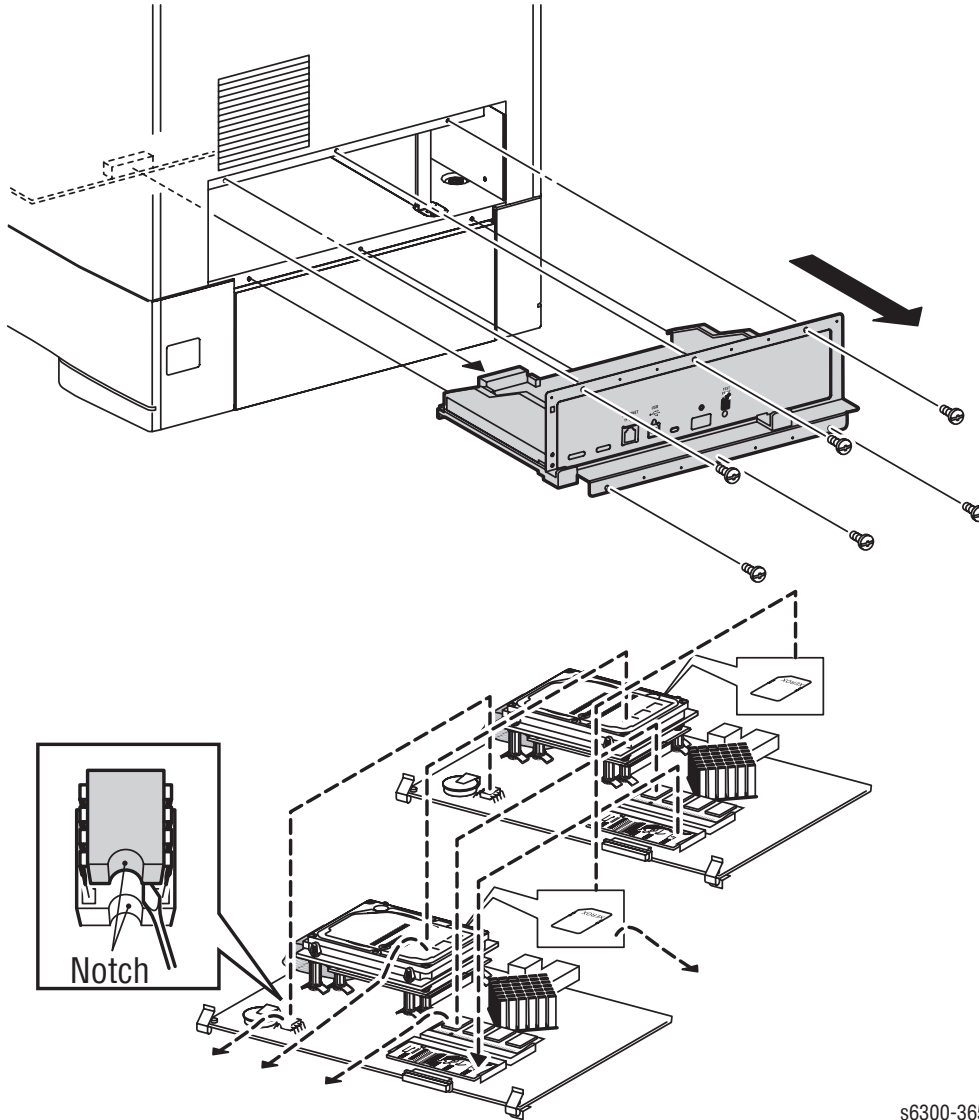

s6300-365

3. Transfer the installed Memory, NVRAM, Configuration Card, and Hard Drive from the old board to the new board.

Replacement Note

Print a Configuration Page after the new board is installed to ensure the customers configuration is restored.

LVPS (PL9.1.4)

The Low Voltage Power Supply (LVPS) assembly consists of the power supply, attached power switch, the AC Inlet Harness, and the surrounding enclosure.

1. Remove the Top Main Cover (page 8-8).
2. Remove the Right Side Cover (page 8-12).
3. Remove the Left Side Cover (page 8-13).
4. Remove the Rear Cover (page 8-16).
5. Unplug connectors (P/J161, 162, 163, 164, 165) from the LVPS.
6. Remove the 2 screws (metal, 6 mm) that secure the LVPS to the Toner Cartridge Holder Assembly.
7. Remove the 3 screws (metal, 6 mm) that secure the LVPS to the printer chassis.
8. Remove the screw (self-tapping, plastic 10mm) located at the bottom of the LVPS, that secures it to Tray 2.
9. Remove the harnesses from the Rear Cable Guide.
10. Remove the screw (self-tapping, plastic 10mm) that secures the Power Switch Link Shaft support and remove the support.

Note

In the step below, do not remove the Switch Link Shaft from the printer.

10. Release the Power Switch Link Shaft from the notch in the LVPS and lift up to remove the LVPS.

Replacement Note

Align the bosses at the base of the LVPS to those on the frame. Also, P/J167 has no connection.

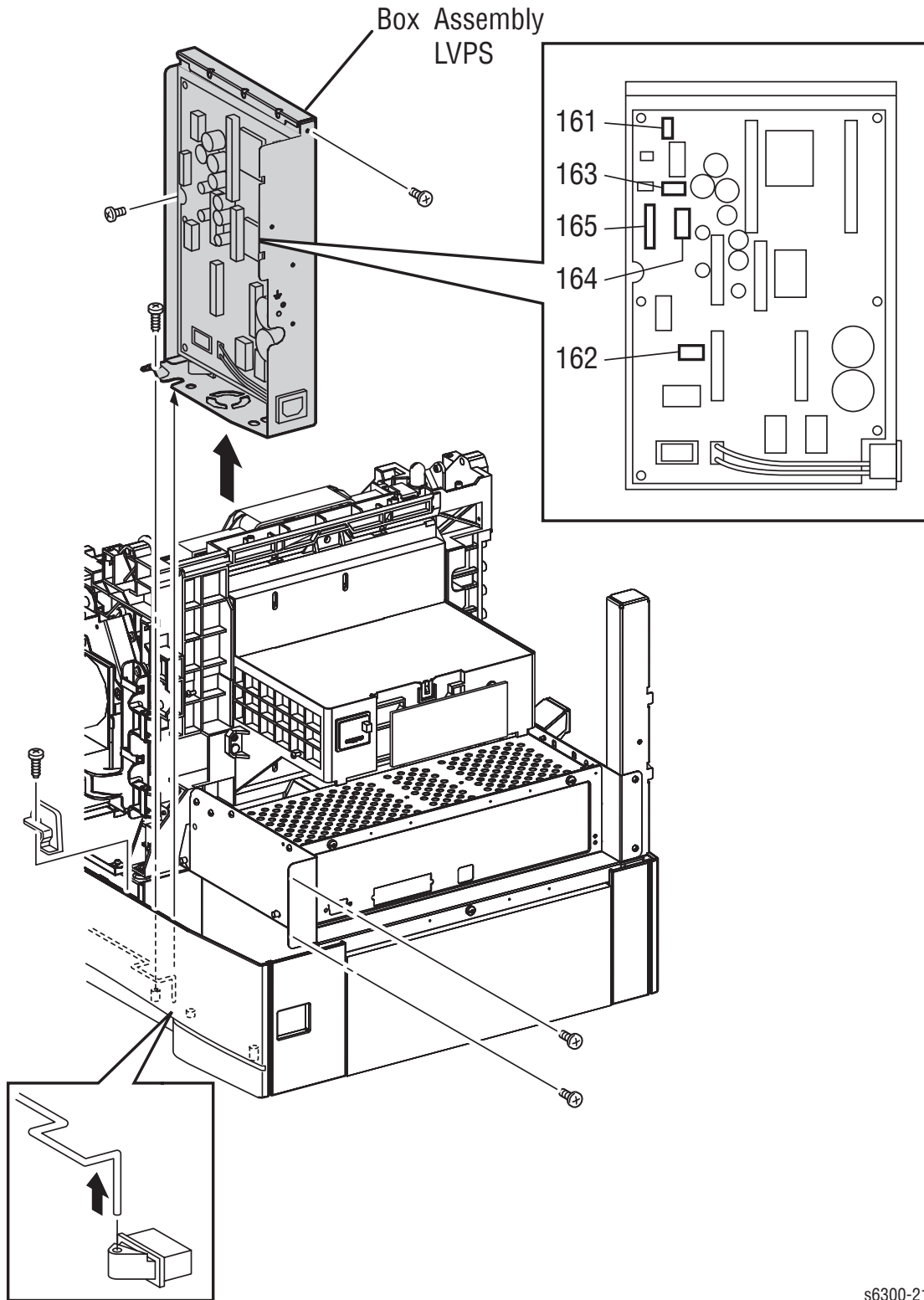

s6300-213

Interlock Switch (PL9.1.11)

1. Remove the Top Main Cover (page 8-8).
2. Remove the Right Side Cover (page 8-12).
3. Unplug the Interlock Switch connector (P/J161) from the LVPS.
4. Remove the Interlock Switch harness from the clamp on the LVPS.
5. Release the two clamps on the Developer Drive Assembly that secure the Interlock Switch harness.
6. Remove the Developer Drive Assembly (page 8-93).
7. Remove the Interlock Switch from the printer.

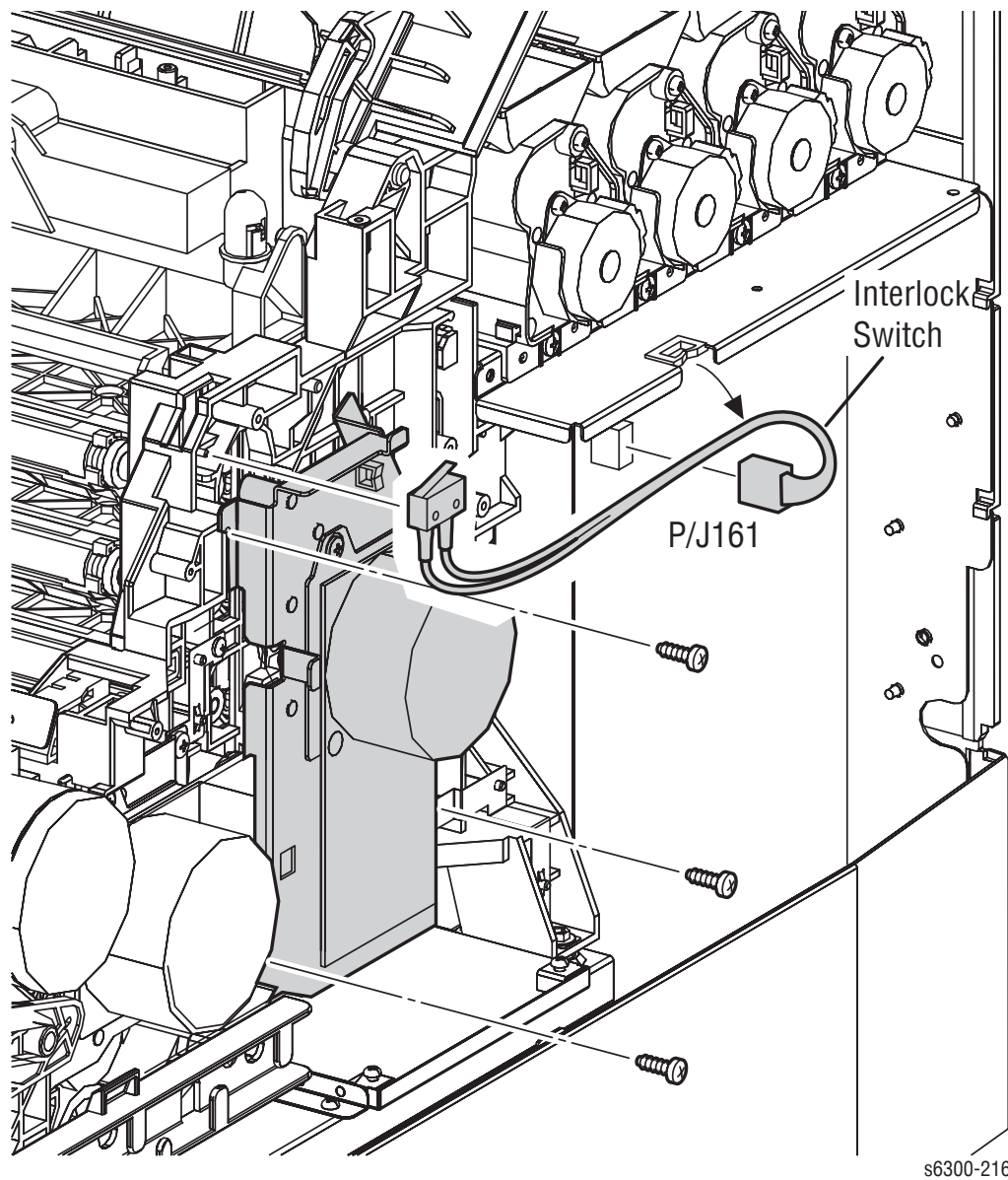

Replacement Note

Position the Interlock Switch on the boss provided on the frame. Also, when replacing the motor, rotate the motor housing to engage the drive gears. Verify that the gears are engaged before installing the screws.

Rear Fan (PL1.1.19)

1. Remove the Top Main Cover (page 8-8).
2. Remove the Right Side Cover (page 8-12).
3. Remove the Left Side Cover (page 8-13).
4. Remove the Rear Cover (page 8-16).
5. Remove 2 screws (self-tapping, plastic 35 mm) that secure the Rear Fan to the Rear Cover.

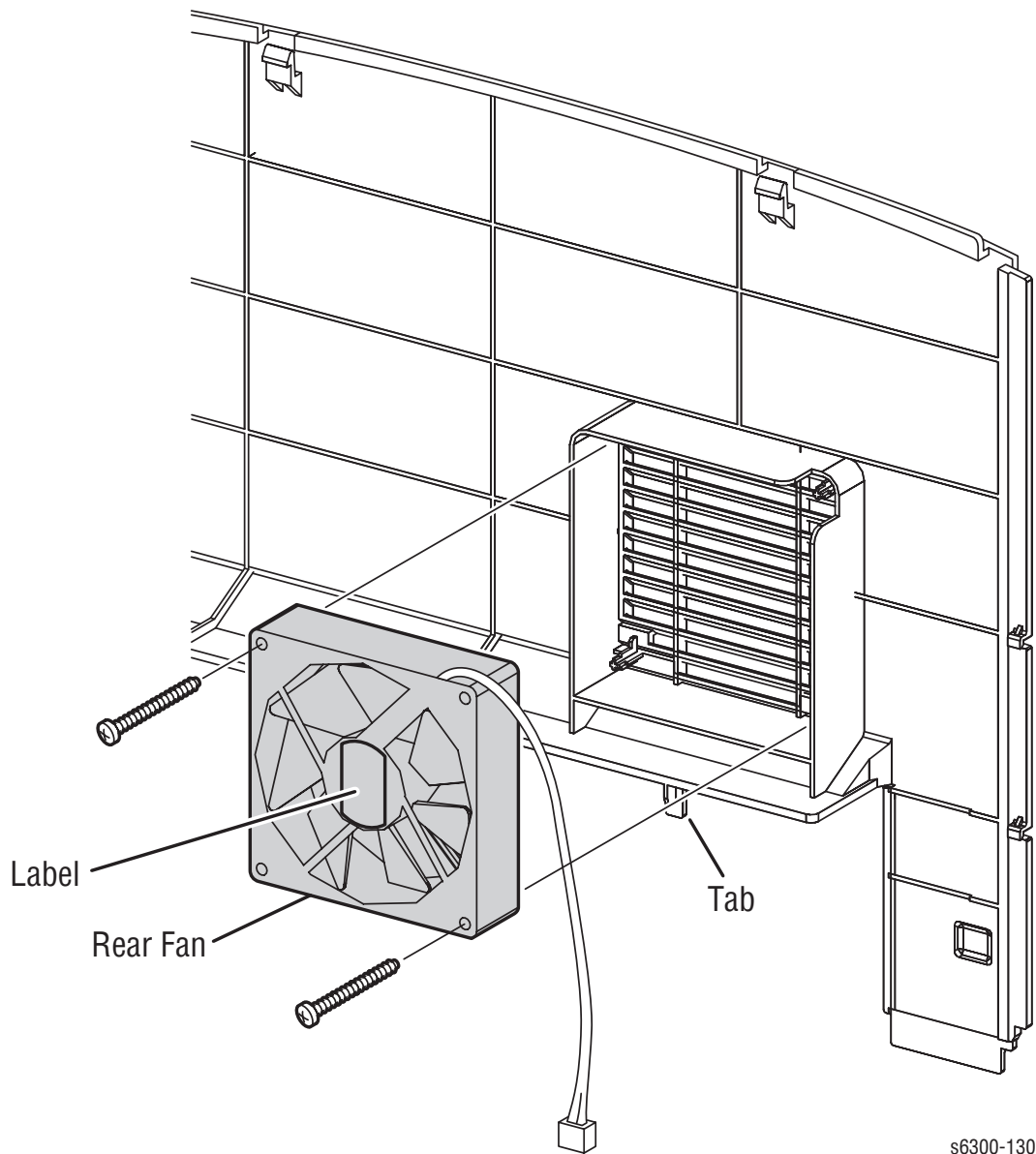

Replacement Note

Upon reassembly, attach the Rear Fan so its label faces towards the inside of the printer and the tabs of the Rear Cover engage the frame.

EEPROM Board (PL9.1.12)

1. Remove the Top Main Cover (page 8-8).
2. Remove the Right Side Cover (page 8-12).
3. Remove the 4 clamps that hold the harness in the Rear Harness Guide and remove the harness.
4. Remove the 2 screws (self-tapping, plastic 10 mm) that secure the Rear Harness Guide.
5. Unplug connector (P/J144) from the EEPROM Board.
6. Remove the screw (self-tapping, plastic 10 mm) that secures the EEPROM Board and remove.

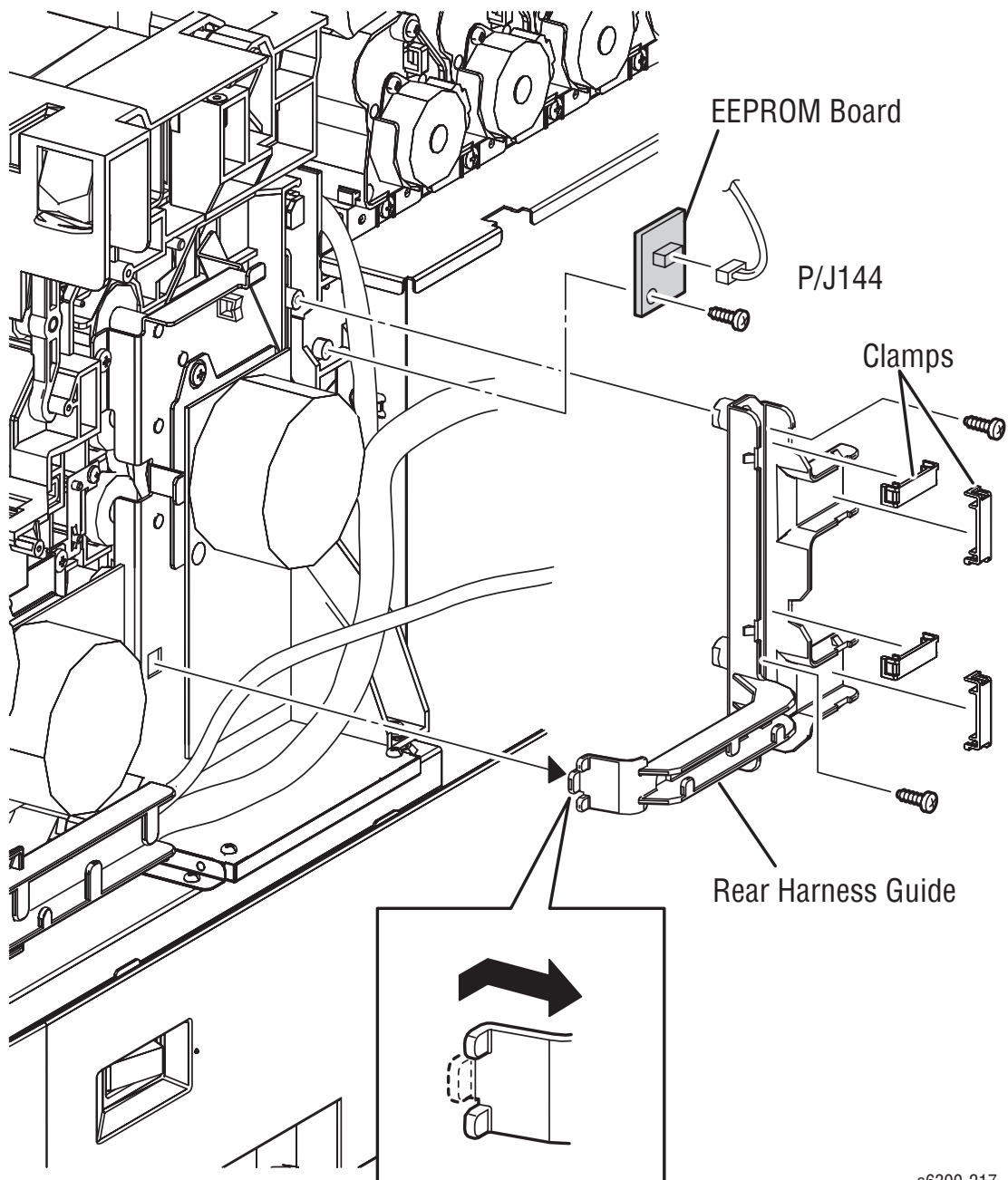

s6300-217

Engine Control Board (PL9.1.16)

Caution

Critical printer-specific information is stored in the NVRAM device located on the Engine Control Board. You can either save this information to the Image Processor Board using the Service Diagnostic Store/Restore utilities or exchange the NVRAM devices between the new and old boards.

1. If the printer is functional, save the NVRAM data using the Service Diagnostic utilities before starting disassembly.

Caution

Observe proper ESD procedures when handling any circuit board.

2. Remove the Top Main Cover (page 8-8).
3. Remove the Right Side Cover (page 8-12).
4. Remove the Left Side Cover (page 8-13).
5. Remove the Rear Cover (page 8-16).
6. Remove the Image Processor Board (page 8-98).
7. Remove the Imaging Unit.

Note

Cover the Developer Frame Assembly with paper to avoid damage to the rollers and Toner spillage. Also, take care not to allow the unplugged connectors to be drawn inside the printer.

8. Push down to release the 2 hooks of the Electrical Cover and remove the cover.
9. Unplug the 3 harnesses on the Engine Control Board accessible from inside the Electrical Cover.
10. Remove the screw (metal, 6 mm) that secures the Engine Control Board Bracket underneath the Electrical Cover.
11. Disconnect connectors P/J151, P/J141, and P/J3411 connected to the Laser Unit, HVPS, and CRUM Reader.
12. Push these harnesses to the clamp located directly beneath the Laser Unit to provide slack to extract the Engine Control Board.

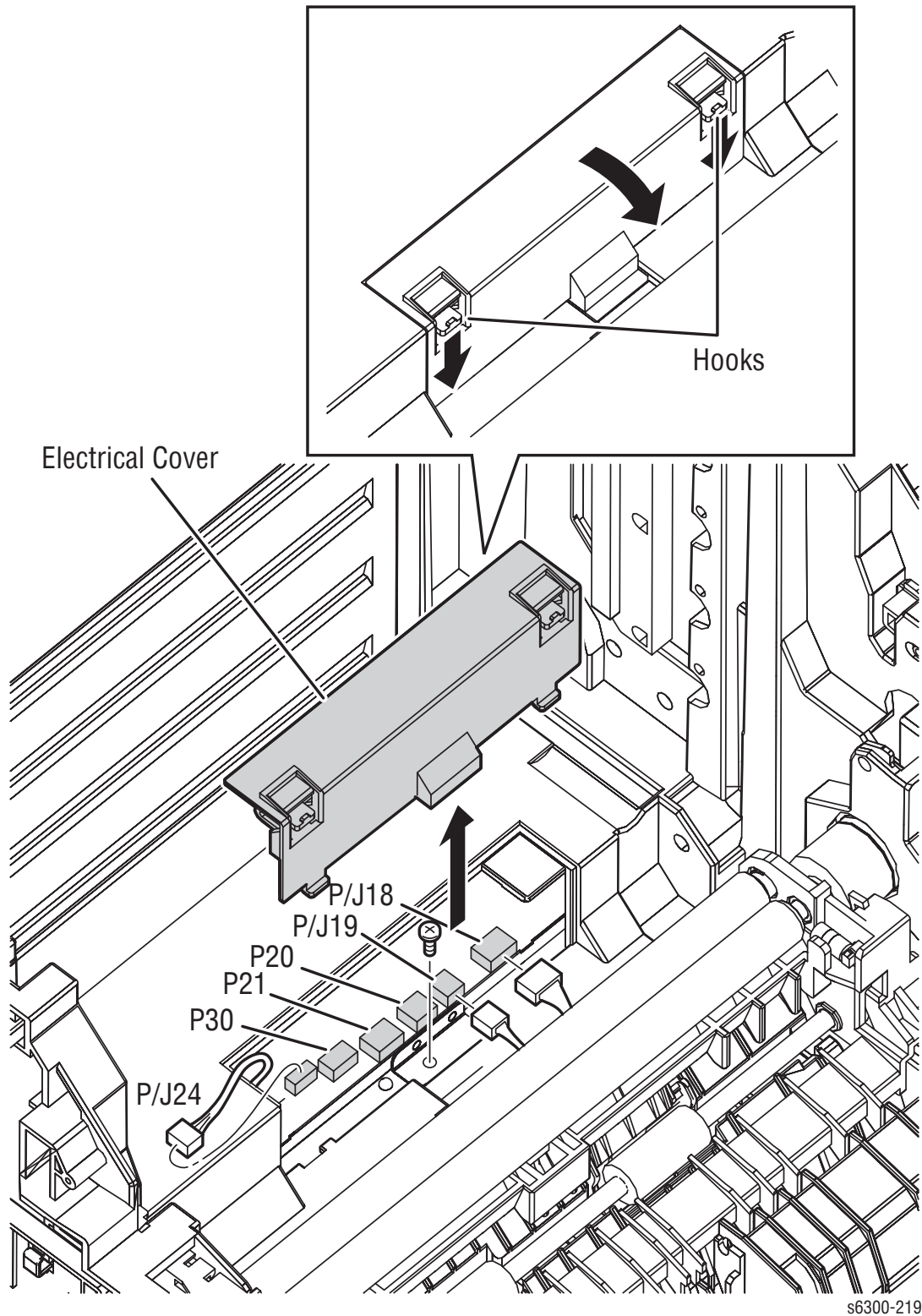

Note

Connectors P20, P21, and P30 on the Engine Control Board are not used.

13. Disconnect P/J17, P/J22, P/J47, P/J52, and P/J60 from the Engine Control Board.
14. Remove the screw (metal, 6 mm) that secures the Engine Control Board Bracket to the right side of the printer.
15. Lift the right edge of the board slightly and pull the Engine Control Board out from the printer while removing connections as they are exposed.

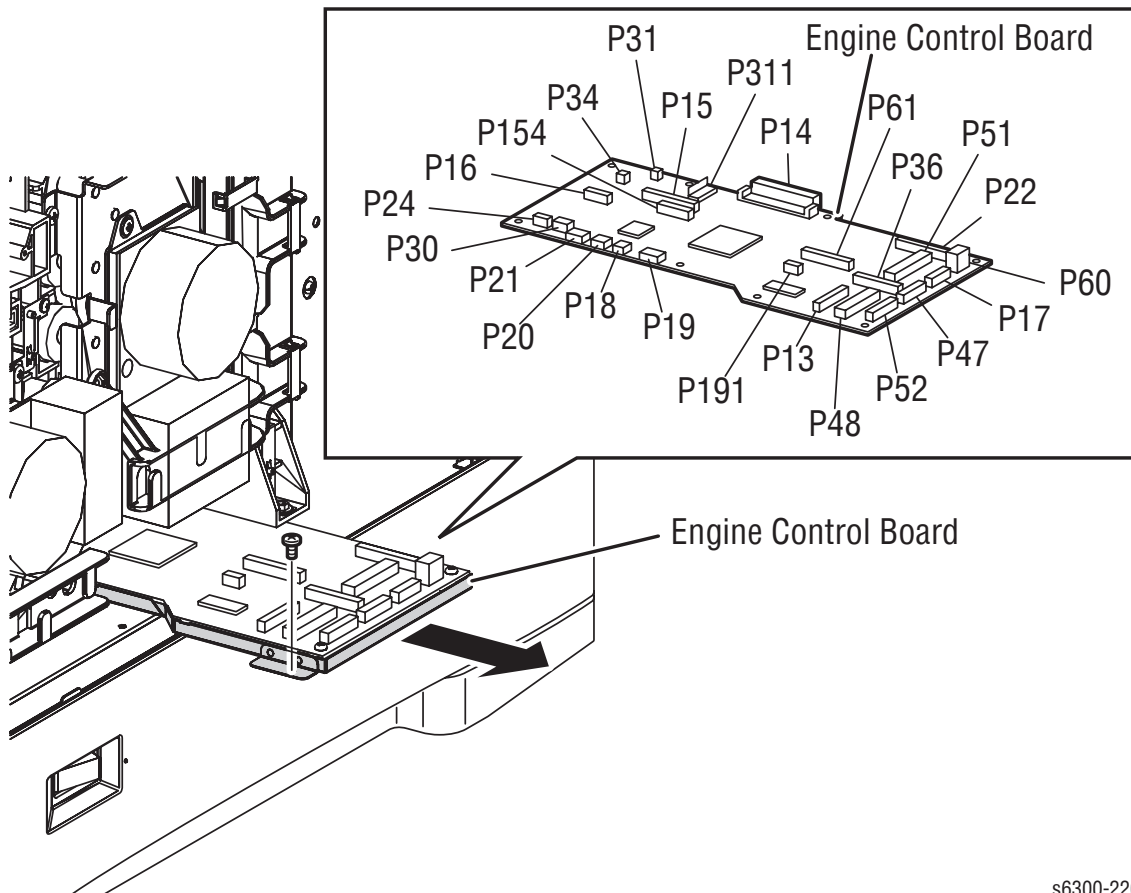

s6300-220

Replacement Note

When replacing the Engine Control Board, either replace the NVRAM device on the new board with the one removed from the old board, or restore the data saved in Step 1 by using the Restore utility included in Service Diagnostics.

Also, reconnect P/J15, P/J16, and P/J34 before reinserting the board into the printer. In addition, connectors P/J13 and P/J36 have an equal number of Pins. These connectors are keyed differently but use care to make certain that the proper connection is being made.

Use care re-routing the harnesses after replacing the board.

The following figure shows the location of the Engine Control Board's NVRAM device.

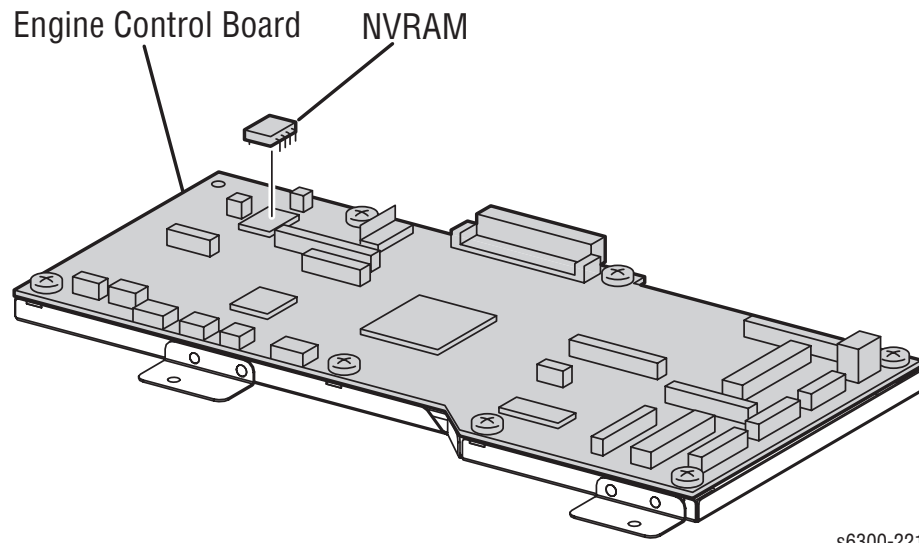

s6300-221

Temperature/Humidity Sensor (PL9.1.20)

1. Remove the Top Main Cover (page 8-8).
2. Remove the Left Side Cover (page 8-13).
3. Press down the knob mounted on the left side of the printer to release the bracket that holds the sensor.
4. Lift the bracket from the printer chassis.
5. Release the 4 hooks that secure the Temperature/Humidity Sensor to the bracket and remove the sensor.
6. Unplug the Temperature/Humidity Sensor connector (CN1).

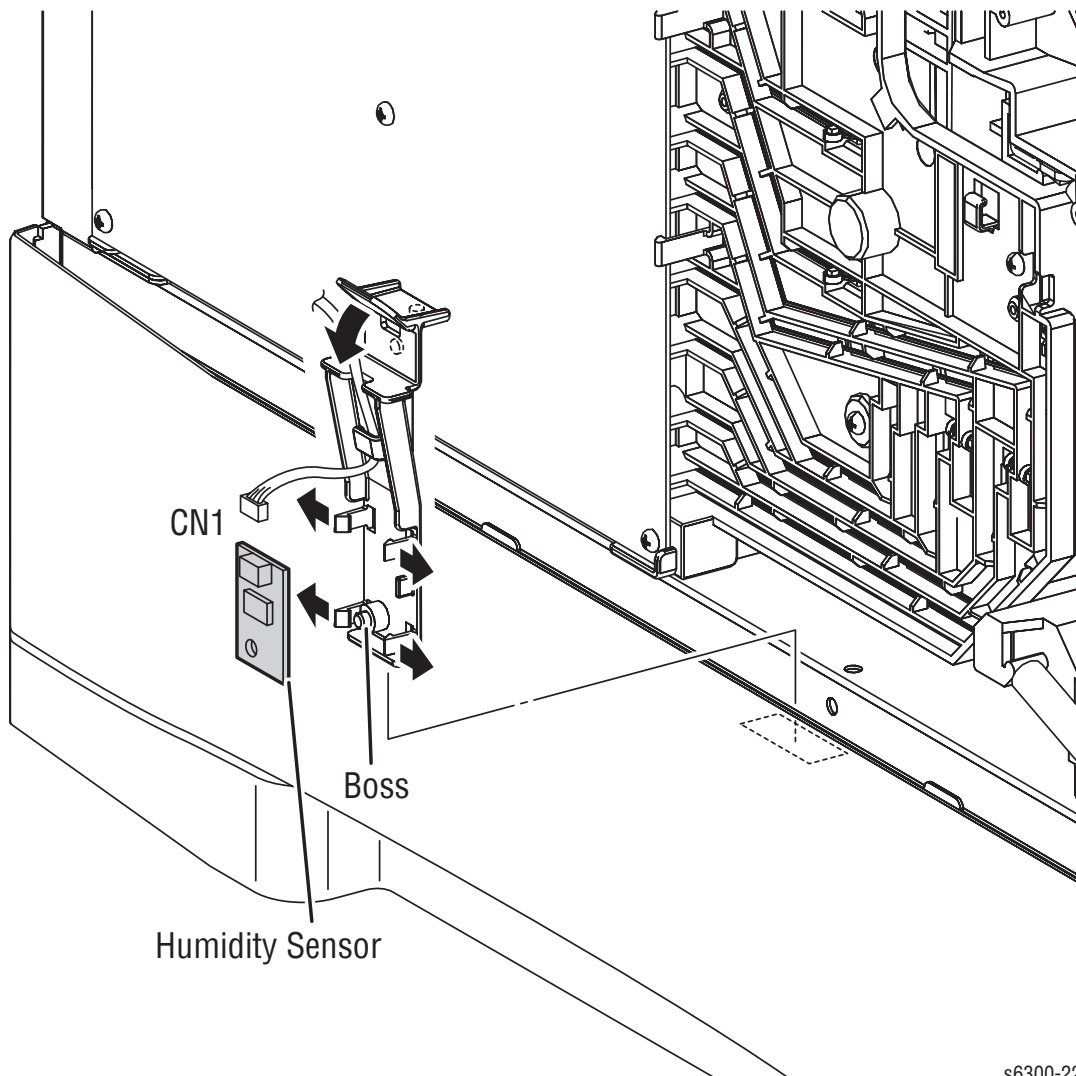

s6300-222

HVPS (PL9.1.21)

1. Remove the Top Main Cover (page 8-8).
2. Remove the Left Side Cover (page 8-13).
3. Unplug connectors P/J139, P/J140, P/J141.
4. From the left side of the printer remove the 2 screws (self-tapping, plastic 10 mm) and 3 screws (metal, 6 mm) that secure the HVPS to the frame.
5. Move the HVPS left to release the retaining hooks on the front edge of the board.

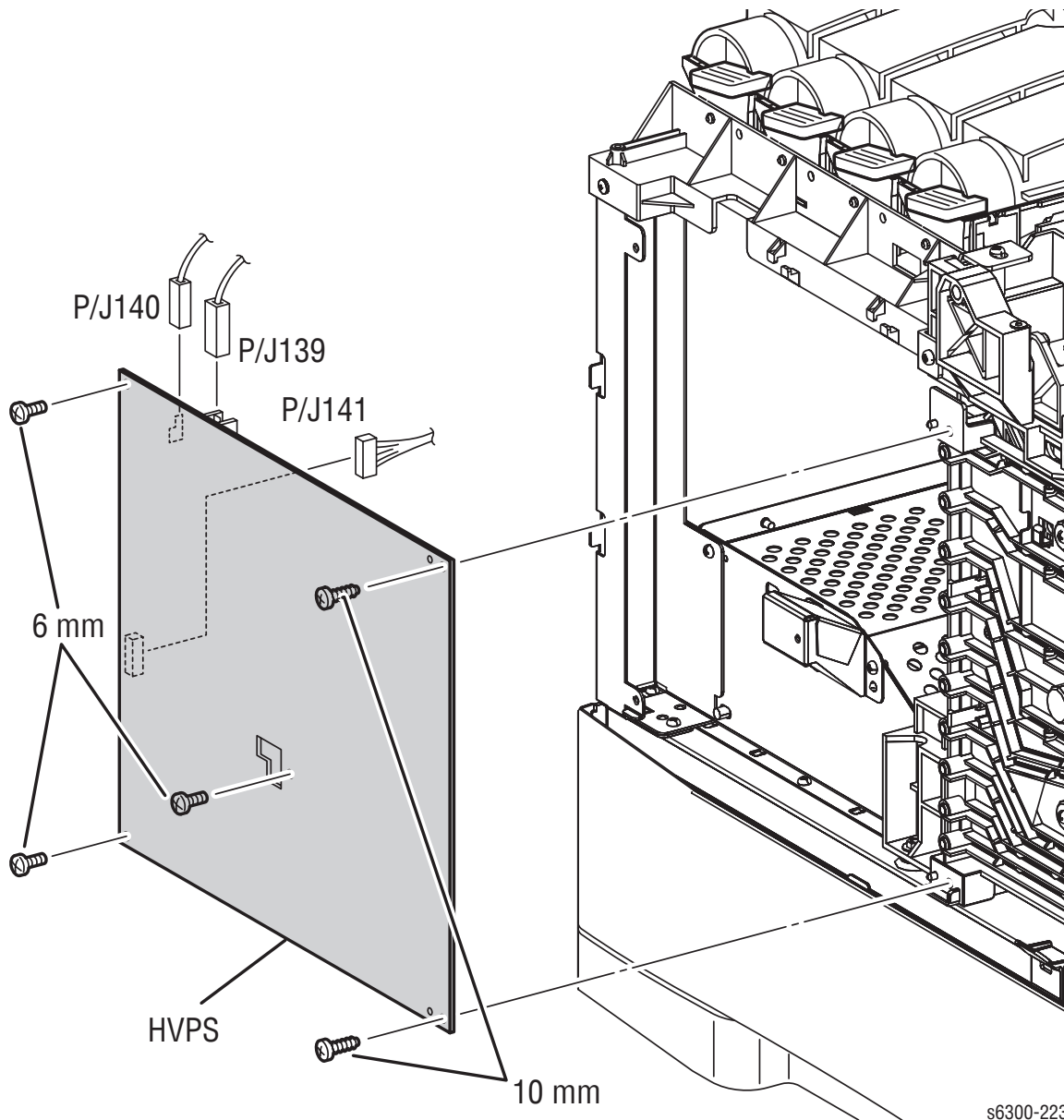

Replacement Note

Verify that the two bosses are aligned and the two retaining hooks are locked on the board before tightening the mounting screws.

Optional 1100-Sheet Feeder Disassembly

Docking (PL12.1.1)

Caution

Lifting the printer requires two people. Use care when removing the printer from the 1100-Sheet Feeder.

1. Pull Tray 2 from the printer.
2. Remove four screws that secure the 1100-Sheet Feeder to the frame of the printer.
3. Lift the printer from the 1100-Sheet Feeder.

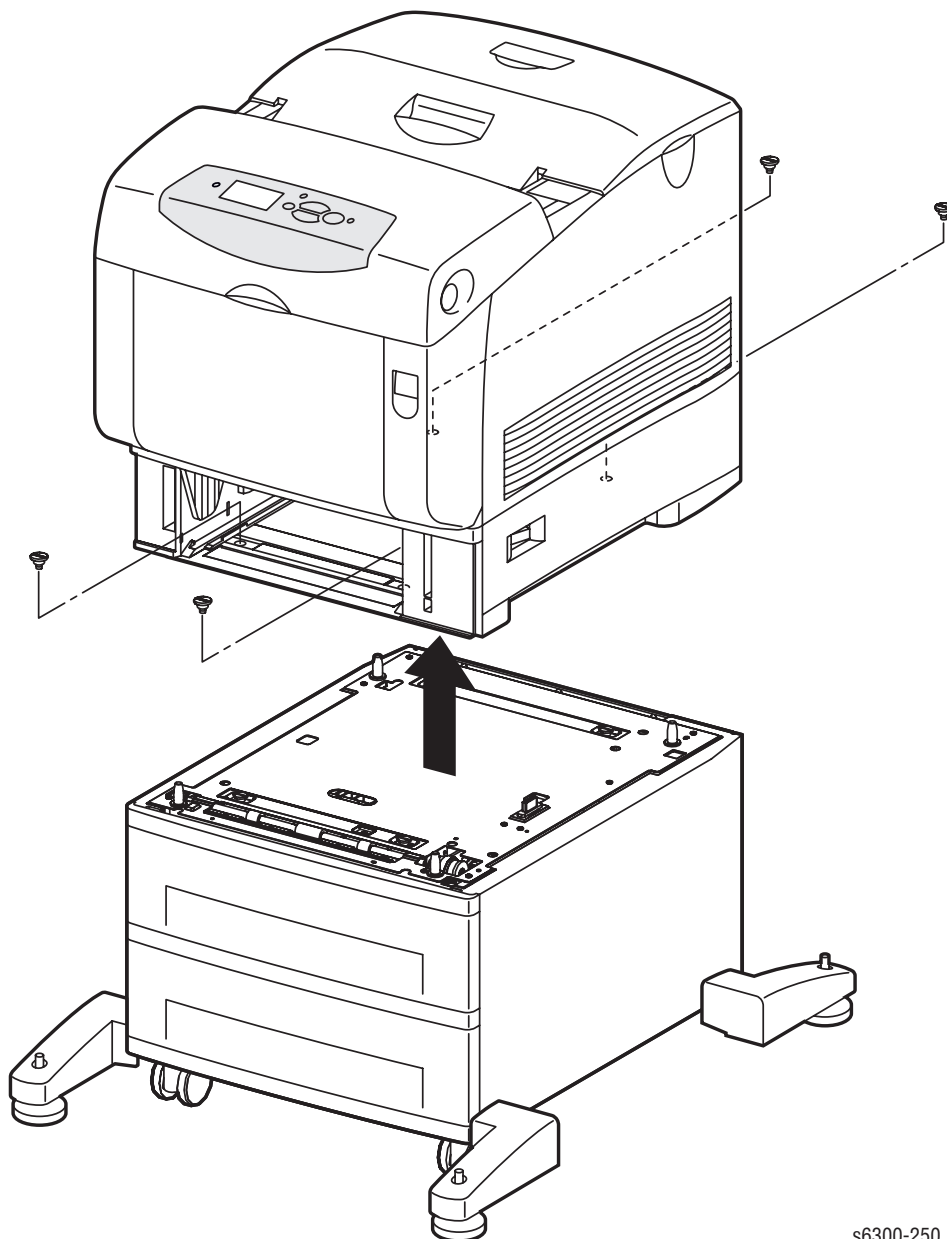

s6300-250

Front Covers (PL12.1.6)

1. Remove the trays.
2. Carefully pry from the bottom the 2 tabs that secure each cover.

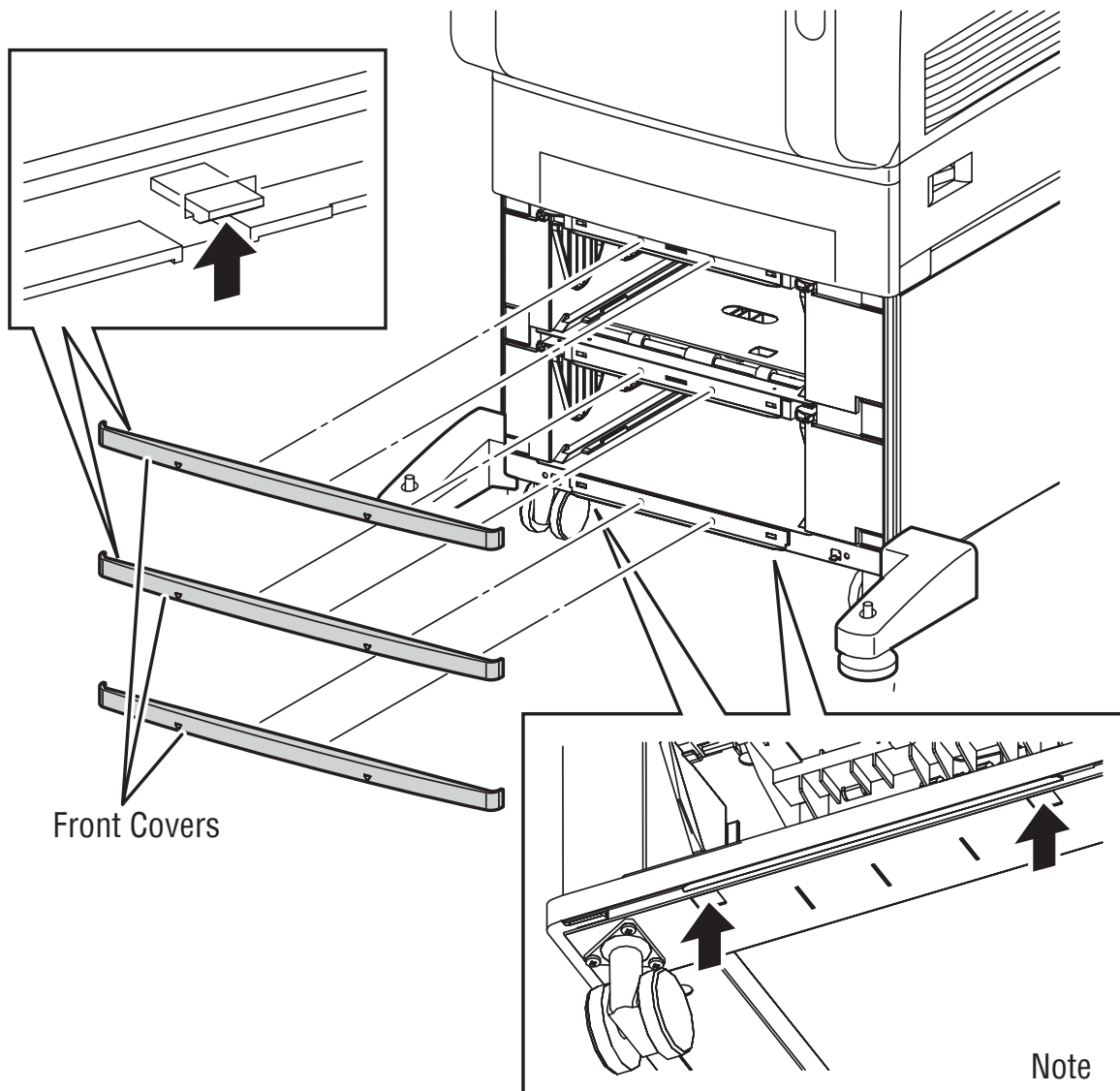

s6300-253

Left Cover (PL12.1.2)

1. Remove the trays.
2. Remove the Front Covers (page 8-111).
3. Remove the 5 screws (metal, flanged, 8 mm) securing the Left Cover.
4. Holding both ends of the cover, lift the cover and move left and right, flexing slightly, to release the tabs from the holes in the frame.

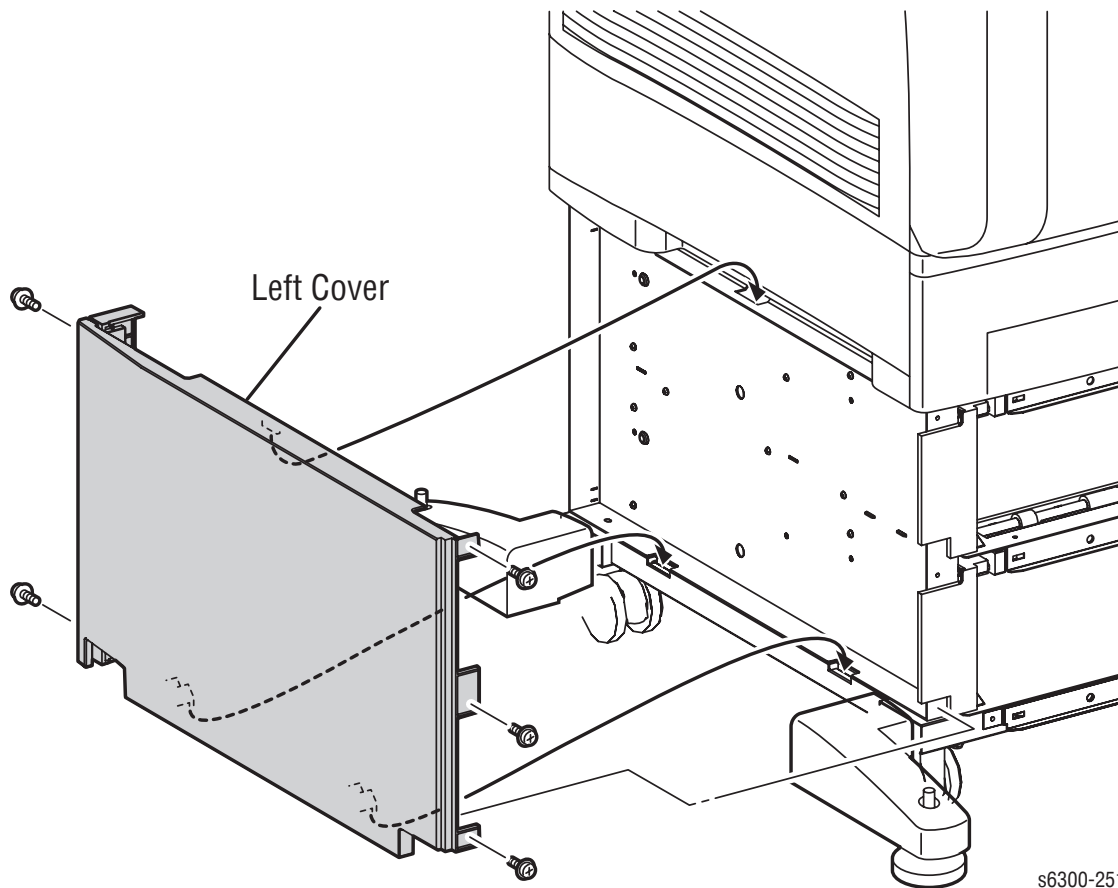

Right Cover (PL12.1.3)

1. Remove the trays.
2. Remove the Front Covers (page 8-111).
3. Remove the 5 screws (metal, flanged, 8 mm) securing the Right Cover.
4. Holding both ends of the cover, lift the cover and move left and right, flexing slightly, to release the tabs from the holes in the frame.

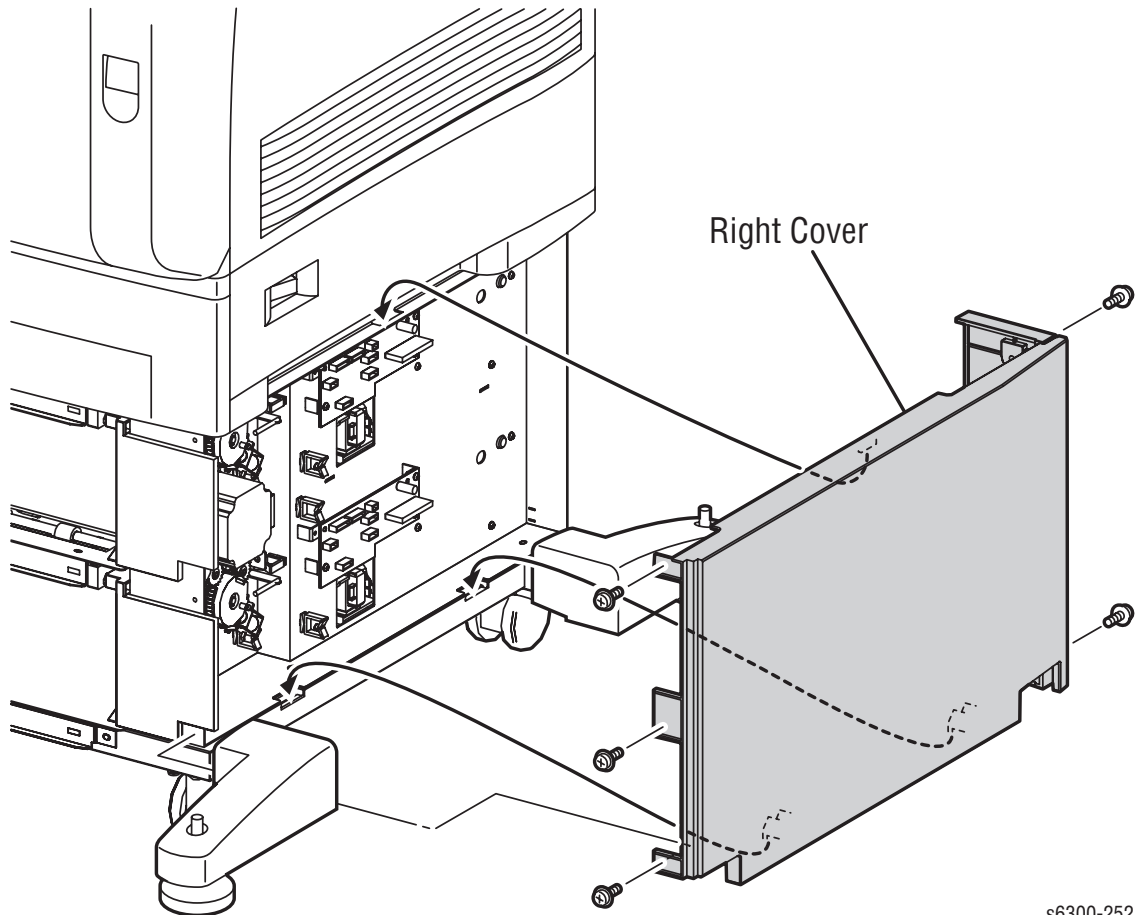

s6300-252

Foot (PL12.1.10)

Because the procedure for removing both feet is the same, the procedure to remove the right side Foot is described below.

1. Remove the Front Covers (page 8-111).
2. Remove the Right Cover (page 8-113).
3. Remove the 2 screws that secure the Foot to the frame.
4. Remove the Foot by pulling it out of the frame.

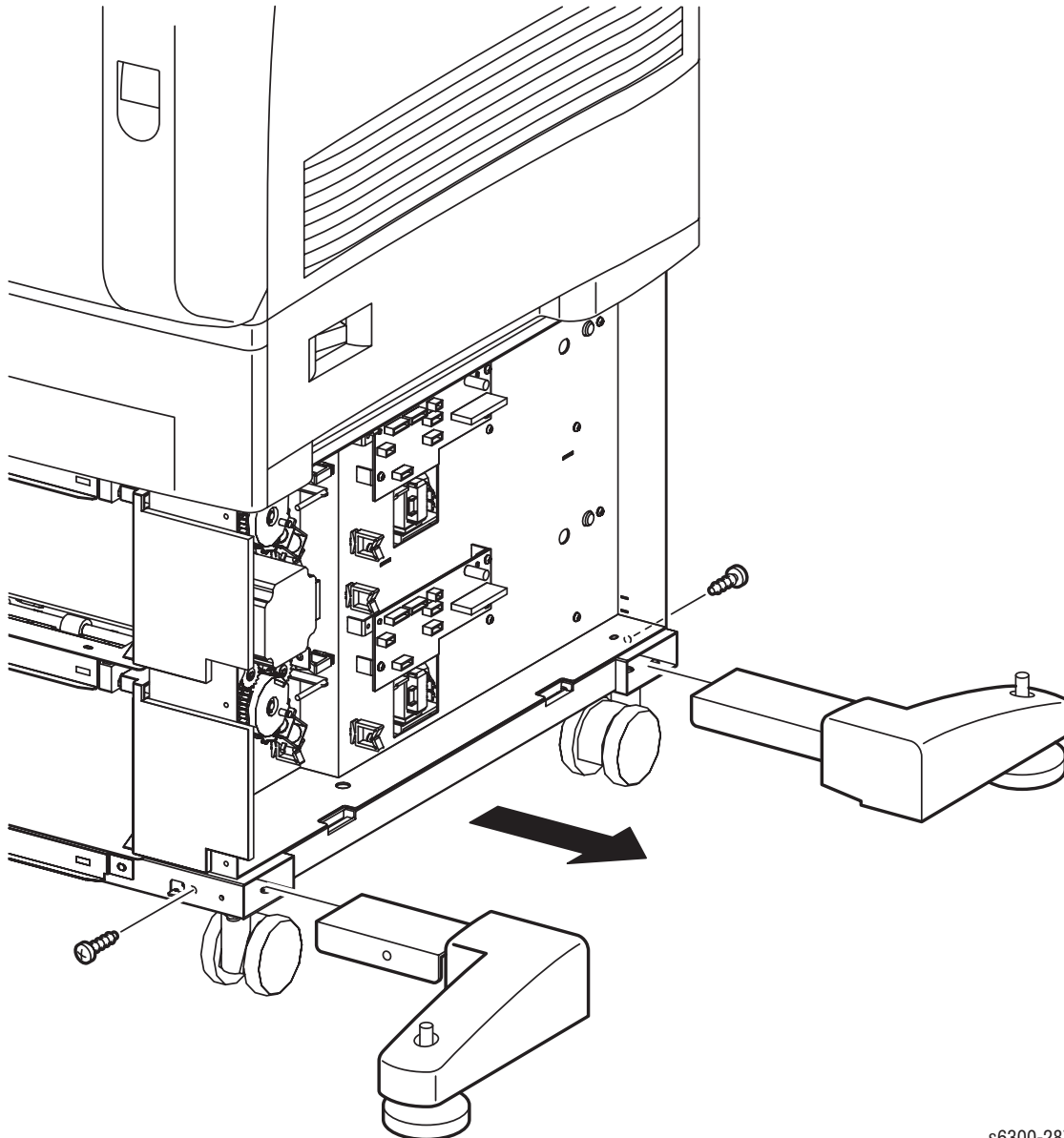

s6300-287

Feeder Chute (PL12.2.7)

1. Remove the tray.
2. Push inward the concaved sections at the left and the right sides and swing the Feeder Chute downward.
3. Release the retainer at one end of the Feeder Chute to release the boss from the Feeder Assembly.
4. Pull the Feeder Chute out, and then down to remove it from the frame.

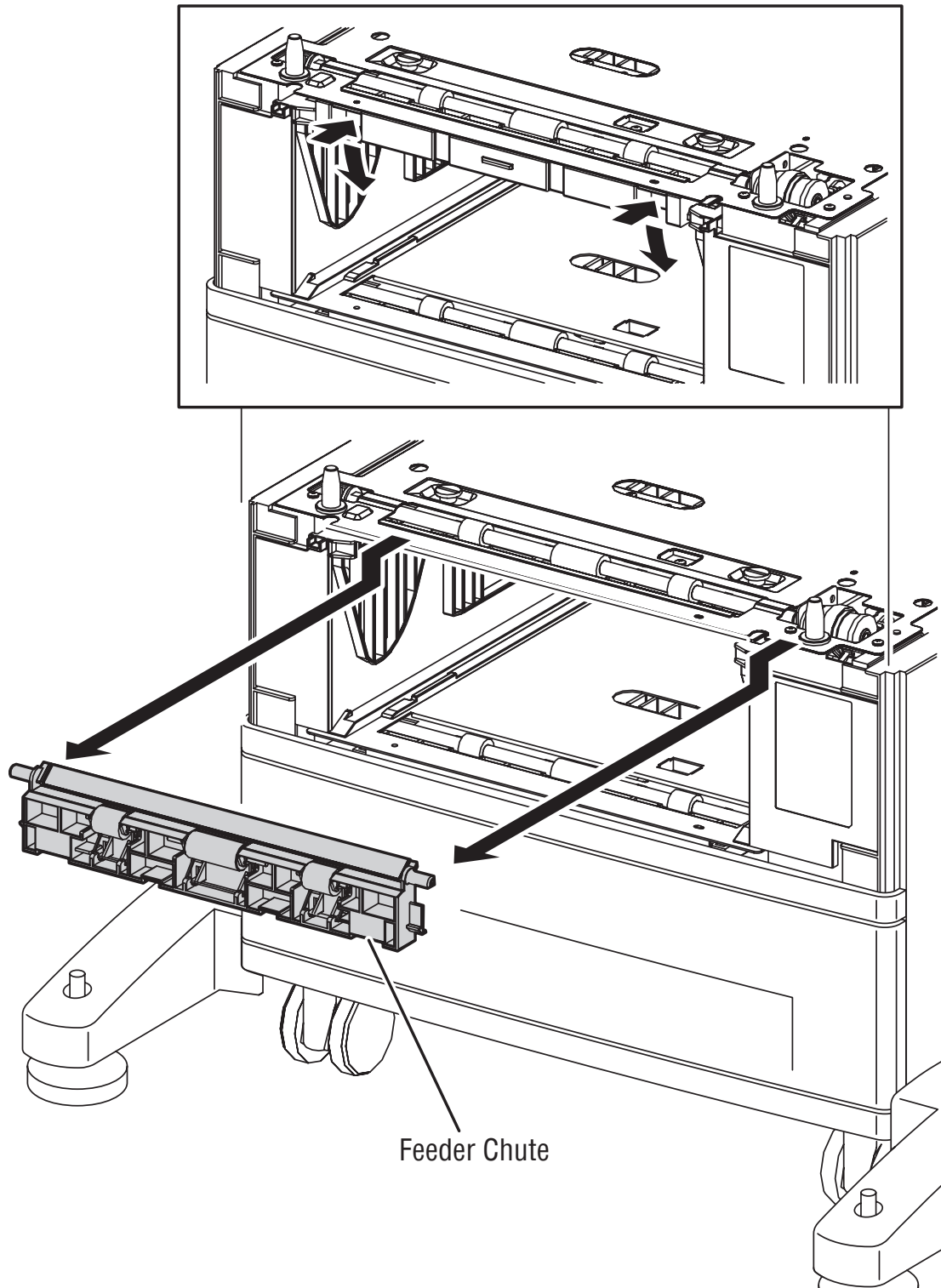

Left Feeder Assemblies (PL12.2.1)

1. Remove the Front Covers (page 8-111).
2. Remove the Left Cover (page 8-112).
3. Remove the Feeder Chute (page 8-115).
4. Remove the Tray Rear Cover (page 8-22).
5. Remove 6 screws (self-tapping, plastic 8 mm) that secure each Left Feeder Assembly to the frame.
6. Remove the Left Feeder Assembly from the front.

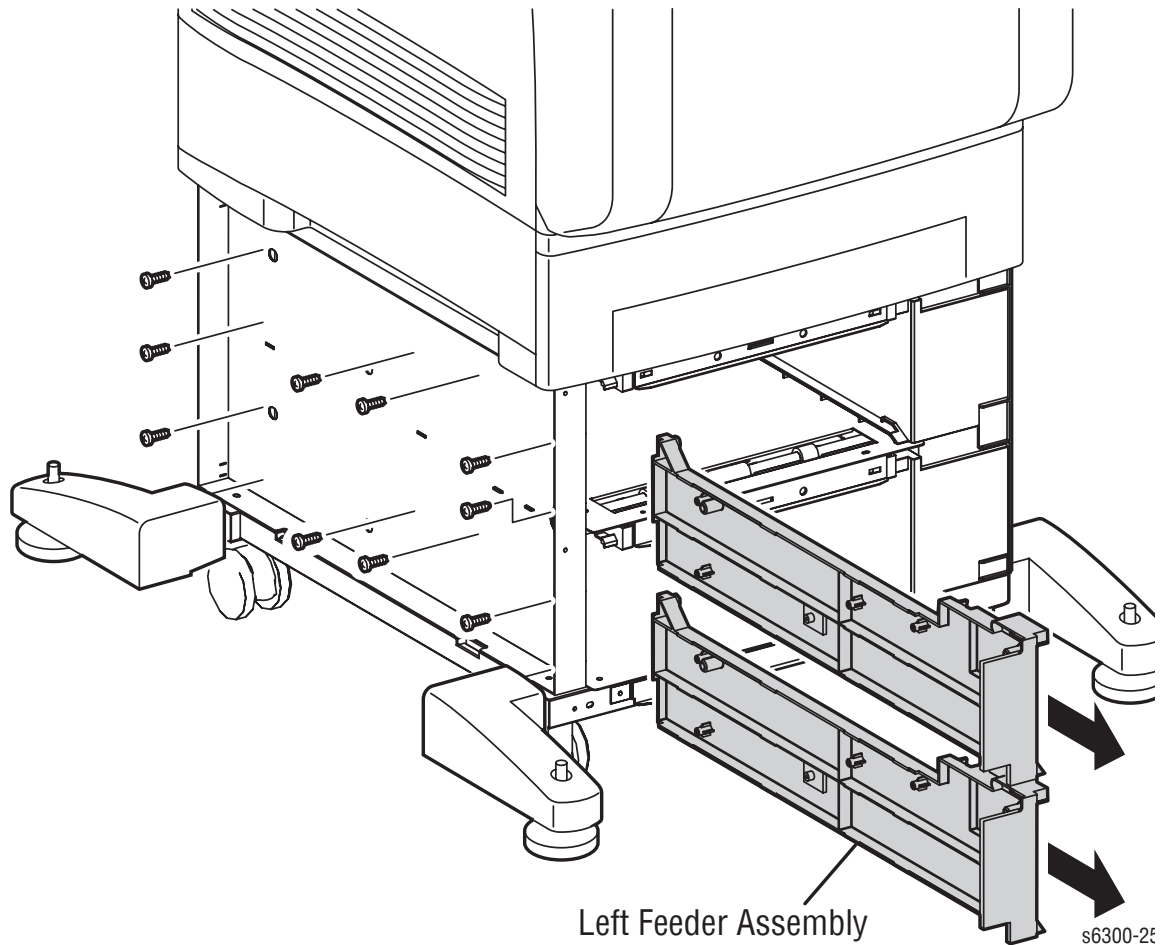

Right Feeder Assemblies (PL12.2.4)

Caution

Move the sensor flags upwards before attempting to remove the feeders.

1. Remove the Front Covers (page 8-111).
2. Remove the Right Cover (page 8-113).
3. Remove the Feeder Chute (page 8-115).
4. Remove the Tray Rear Cover (page 8-22).

Note

Perform Step 5 only when removing the upper Right Feeder Assembly.

5. Remove the Drive Assembly (page 8-121).
6. Remove the Paper Size Switch connector (P/J821).
7. Remove 6 screws (self-tapping, plastic 8 mm) that secure the Right Feeder.
8. Tilt the Right Feeder Assembly and remove it from the front.

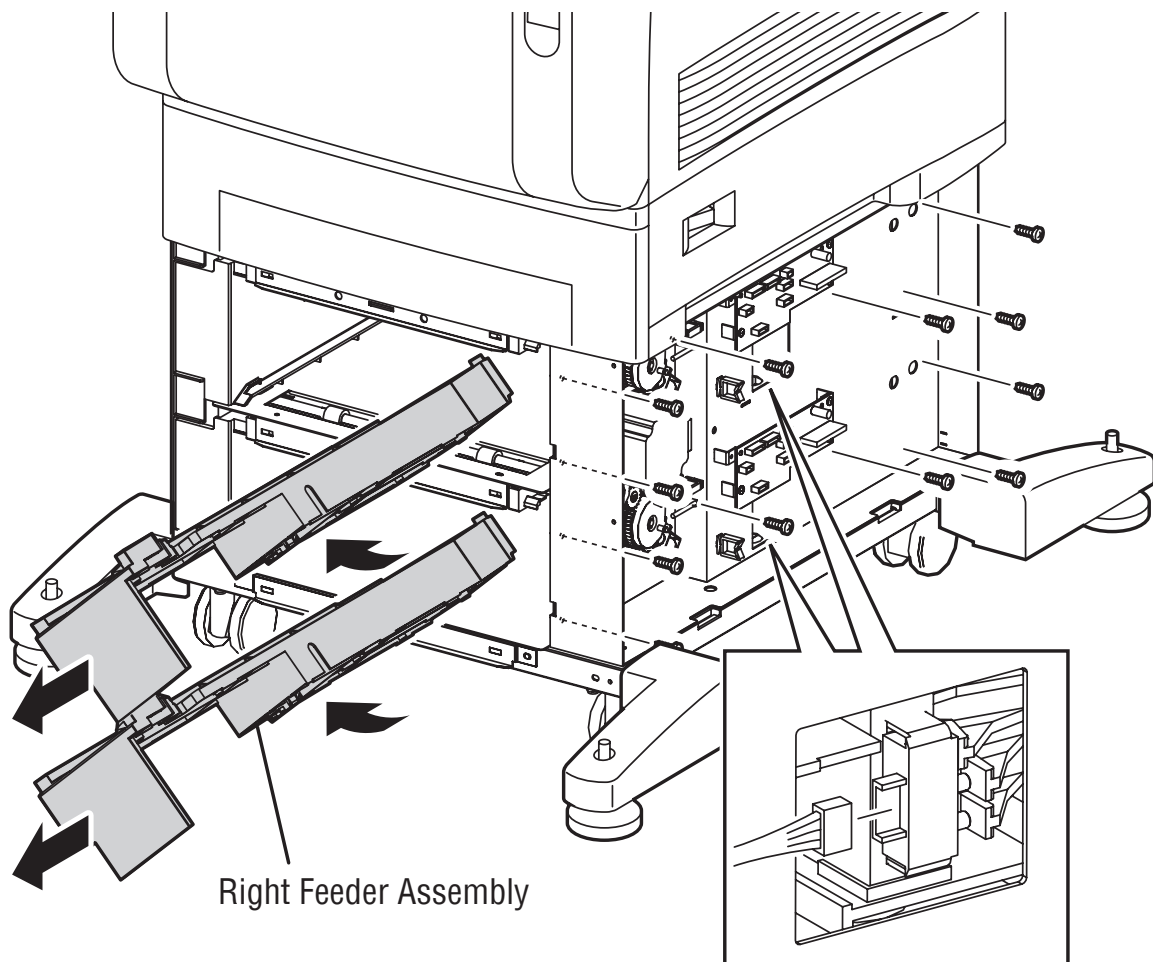

s6300-255

Replacement Note

Replace the Upper Right Feeder before replacing the Drive Motor.

Paper Size Switch (PL12.2.6)

1. Remove the Front Covers (page 8-111).
2. Remove the Right Cover (page 8-113).
3. Remove the Chute Assembly (page 8-115).
4. Remove the Tray Rear Cover (page 8-22).
5. Remove the Right Feeder Assembly (page 8-117).
6. Remove a screw (self-tapping, plastic 8 mm) that secures the Paper Size Switch to the Right Feeder Assembly and remove the switch.

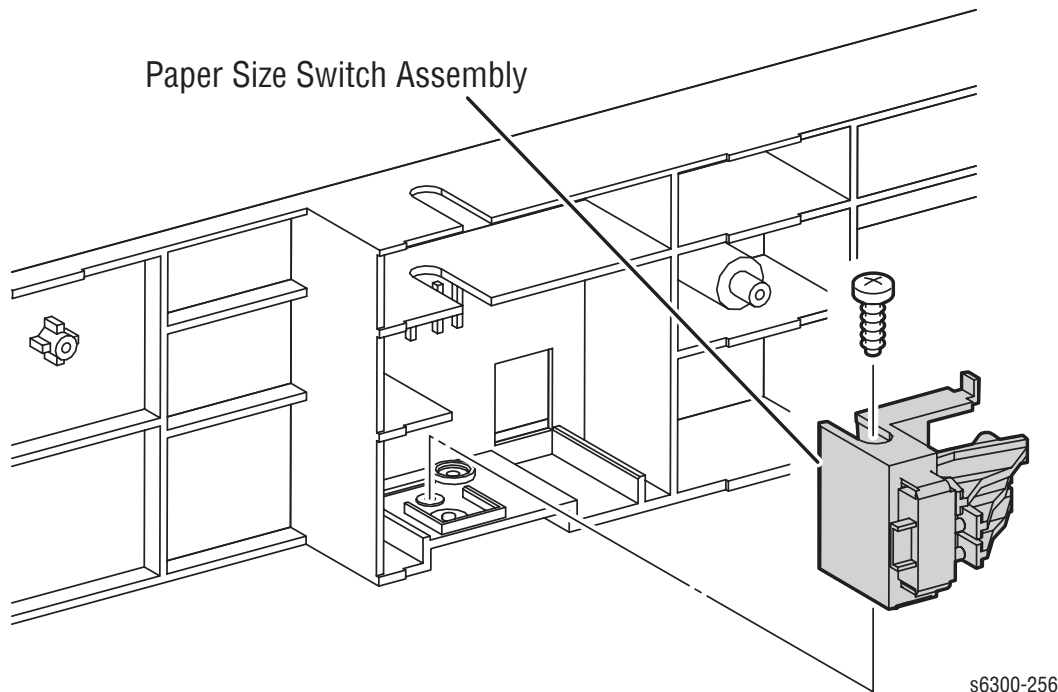

OPTFDR 2 Harness (PL12.3.1)

1. Separate the 1100-Sheet Feeder from the printer (page 8-110).
2. Remove the Front Covers (page 8-111).
3. Remove the Right Cover (page 8-113).
4. Remove connector (P/J83) on the upper Circuit Board HCF.
5. Remove the OPTFDR 2 Harness from clamps.
6. Release two hooks that secure (J172), and remove OPTFDR 2 Harness.

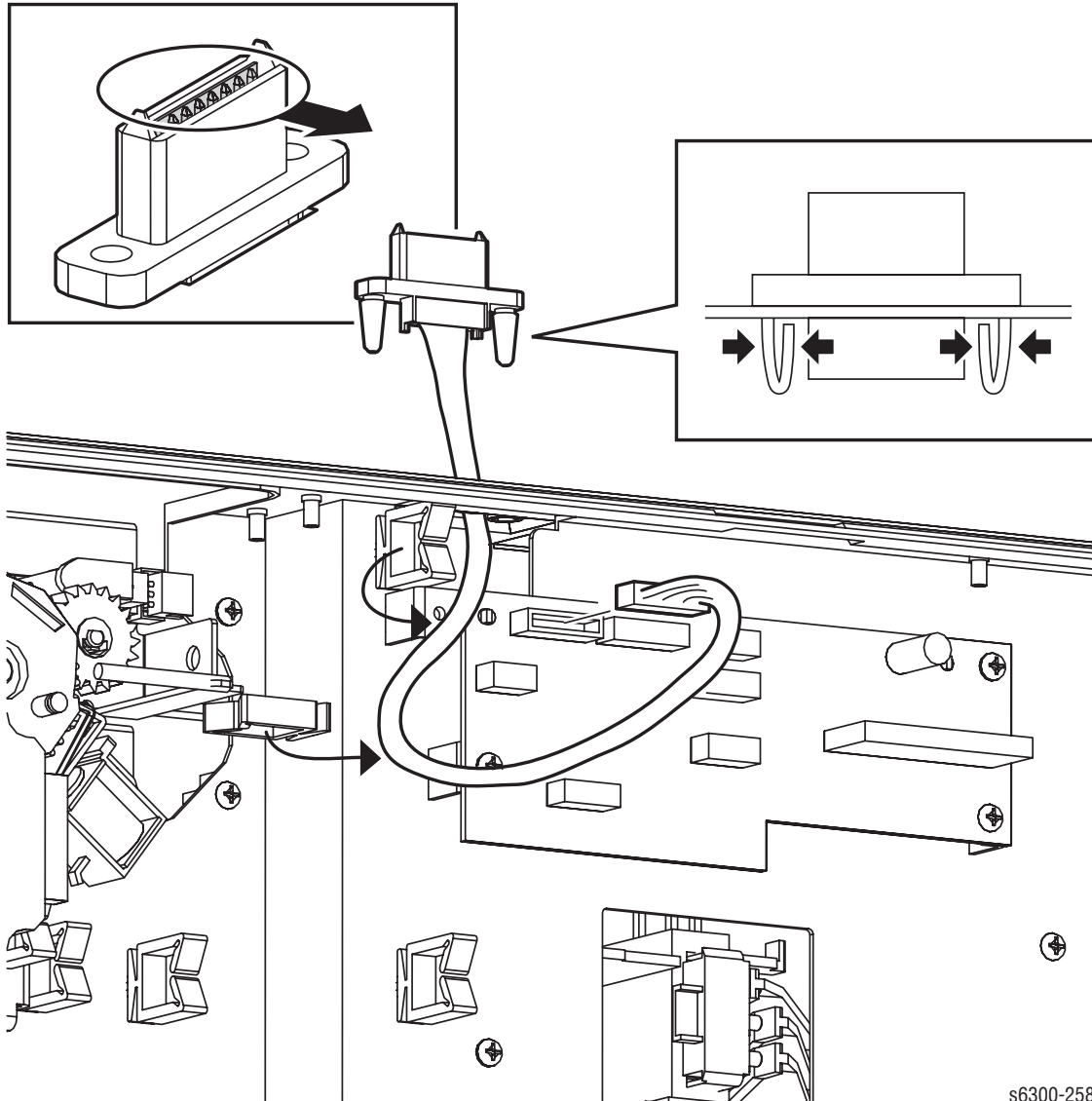

s6300-258

Circuit Board HCF (PL12.3.3)

1. Remove the Front Covers (page 8-111).
2. Remove the Right Cover (page 8-113).
3. Remove all connections to the Circuit Board HCF.
4. Remove the 3 screws (metal, 6mm) that secure the Circuit Board HCF to the frame, and remove.

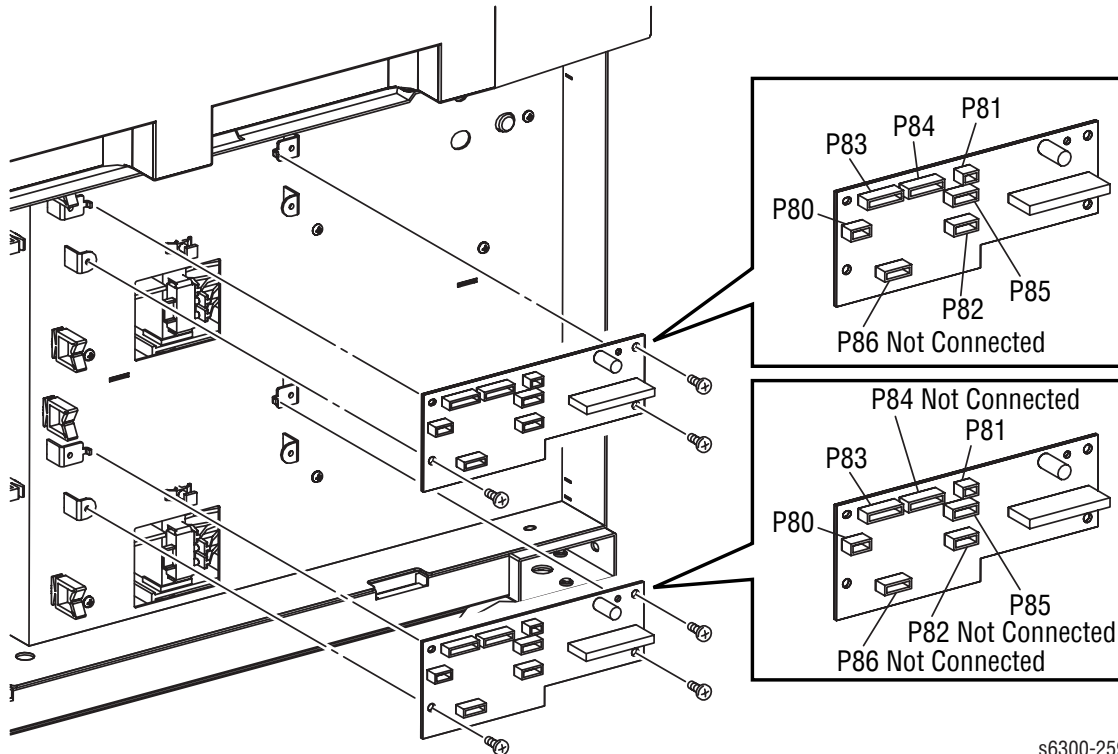

s6300-259

Drive Assembly (PL12.3.9)

1. Remove the Front Covers (page 8-111).
2. Remove the Right Cover (page 8-113).
3. Remove connector (P/J82) that is connected to the upper Circuit Board HCF.
4. Remove the Drive Assembly harness from the Clamps.
5. Remove the 3 screws (metal, 6mm) that secure the Drive Assembly to the frame.

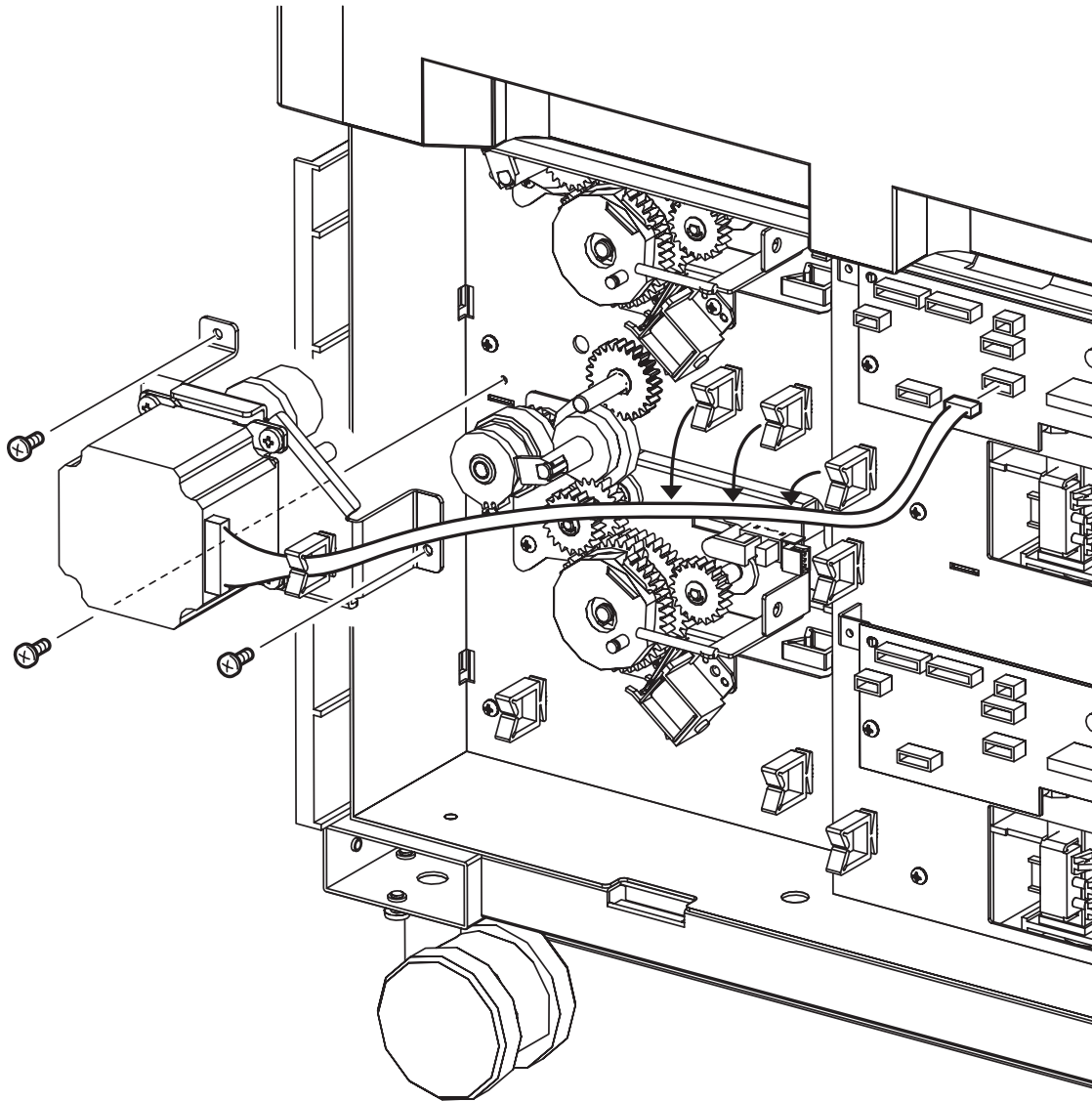

s6300-260

Paper Pick Assembly HCF T1 (PL12.4.1)

1. Separate the 1100-Sheet Feeder from the printer (page 8-110).
2. Remove the Front Covers (page 8-111).
3. Remove the Right Cover (page 8-113).
4. Remove the Left Cover (page 8-112).
5. Remove the Feeder Chute (page 8-115).
6. Remove the Upper Chute (page 8-30).
7. Remove 2 screws (self-tapping, plastic 8 mm) that secure Paper Guide to the Paper Pick Assembly HCF T1 and remove the Paper Guide.

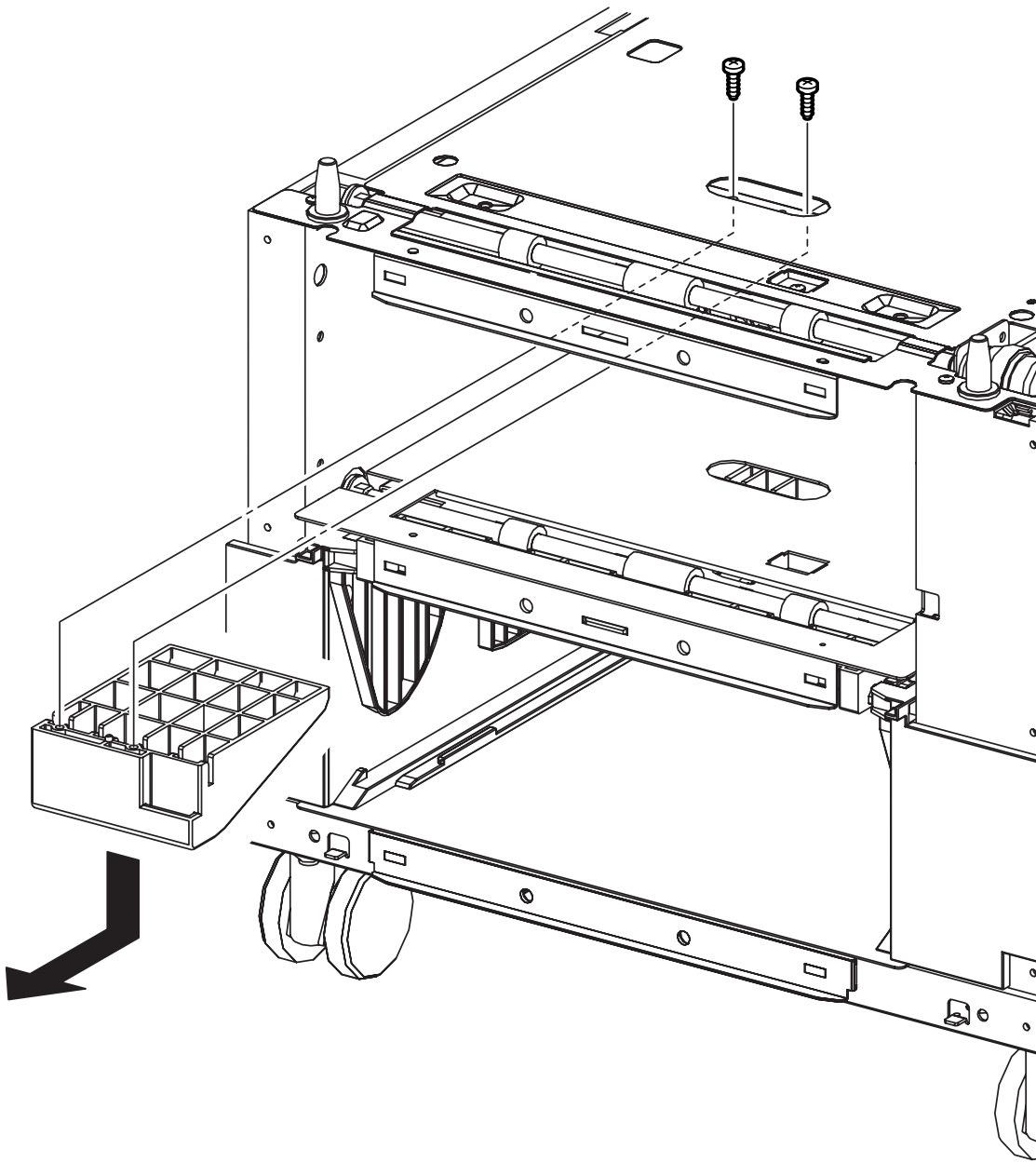

8. Remove the upper Left Feeder Assembly (page 8-116).

9. Remove the upper Right Feeder Assembly (page 8-117).
10. Remove the Drive Assembly (page 8-121).
11. Disconnect the connector (P/J81) from the upper Circuit Board HCF, and remove the harness from clamp.
12. Disconnect the No Paper Sensor connector (P/J822) on upper Paper Pick Assembly.
13. Disconnect the Feed Solenoid connector (P/J824) and remove the harness from the clamp.
14. Disconnect the Turn Roller Clutch connector (P/J825) and remove the harness from the clamp.

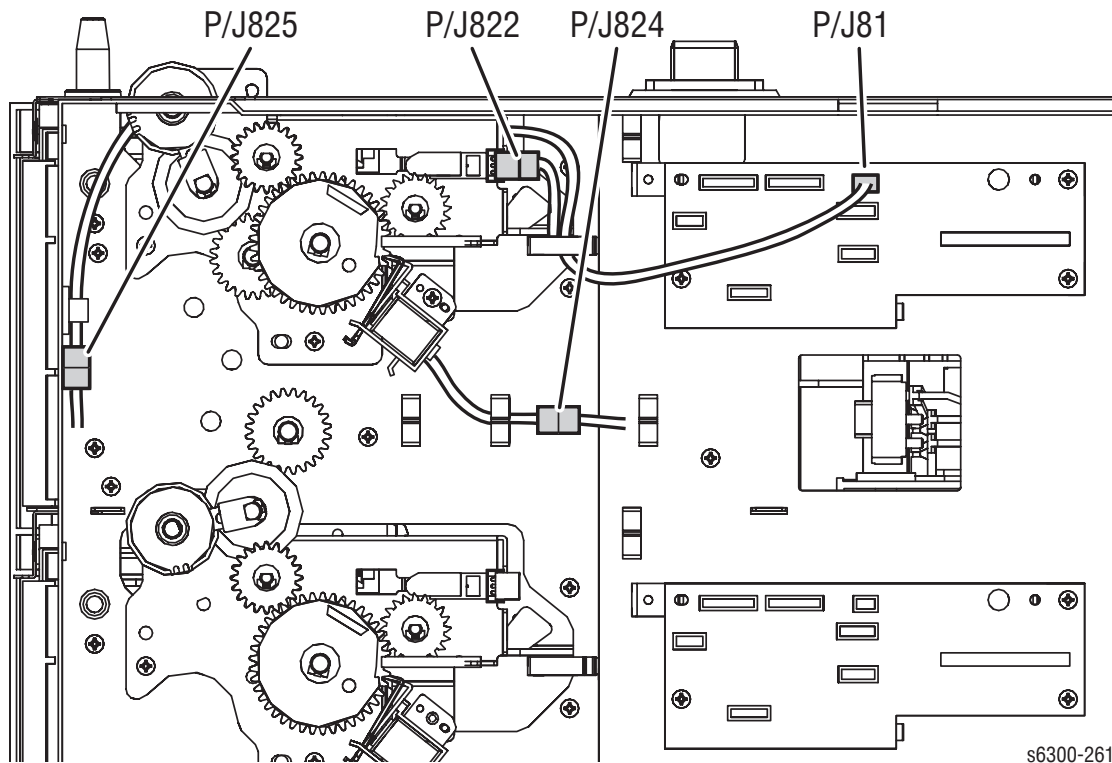

s6300-261

15. Remove 3 screws (metal, 6 mm) that secure the Paper Pick Assembly HCF T1 to the frame, and remove the Paper Pick Assembly HCF T1 from the right.

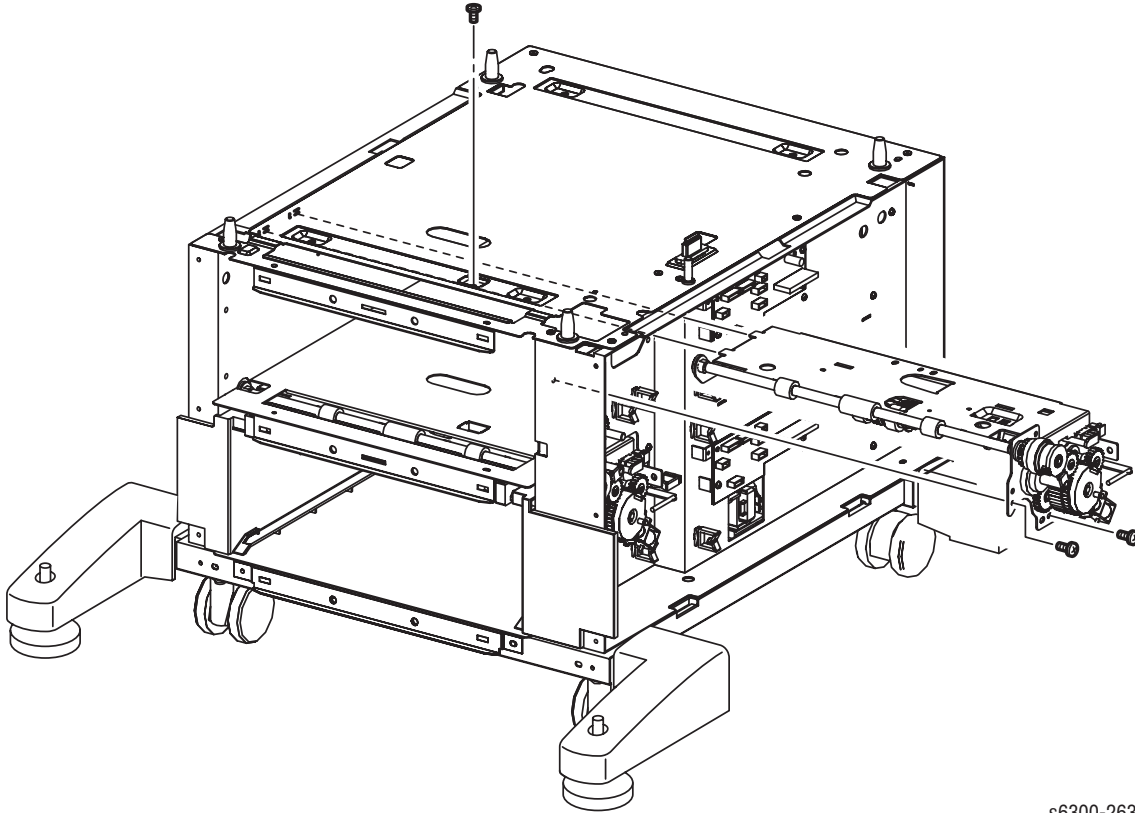

s6300-263

Paper Pick Assembly HCF T2 (PL12.5.1)

With the proper tools, the lower Paper Pick Assembly HCF T2 can be removed from the 1100-Sheet Feeder without removing the Top or the Paper Pick Assembly HCF T1. If a stubby screwdriver is not available, use this procedure:

1. Remove the Paper Pick Assembly HCF T1 (page 8-122).
2. Remove 9 screws (metal, 6 mm) that secure the Top, and remove it.
3. Remove 2 screws (self-tapping, plastic 8 mm) that secure the Paper Pick Assembly HCF T2 Paper Guide.

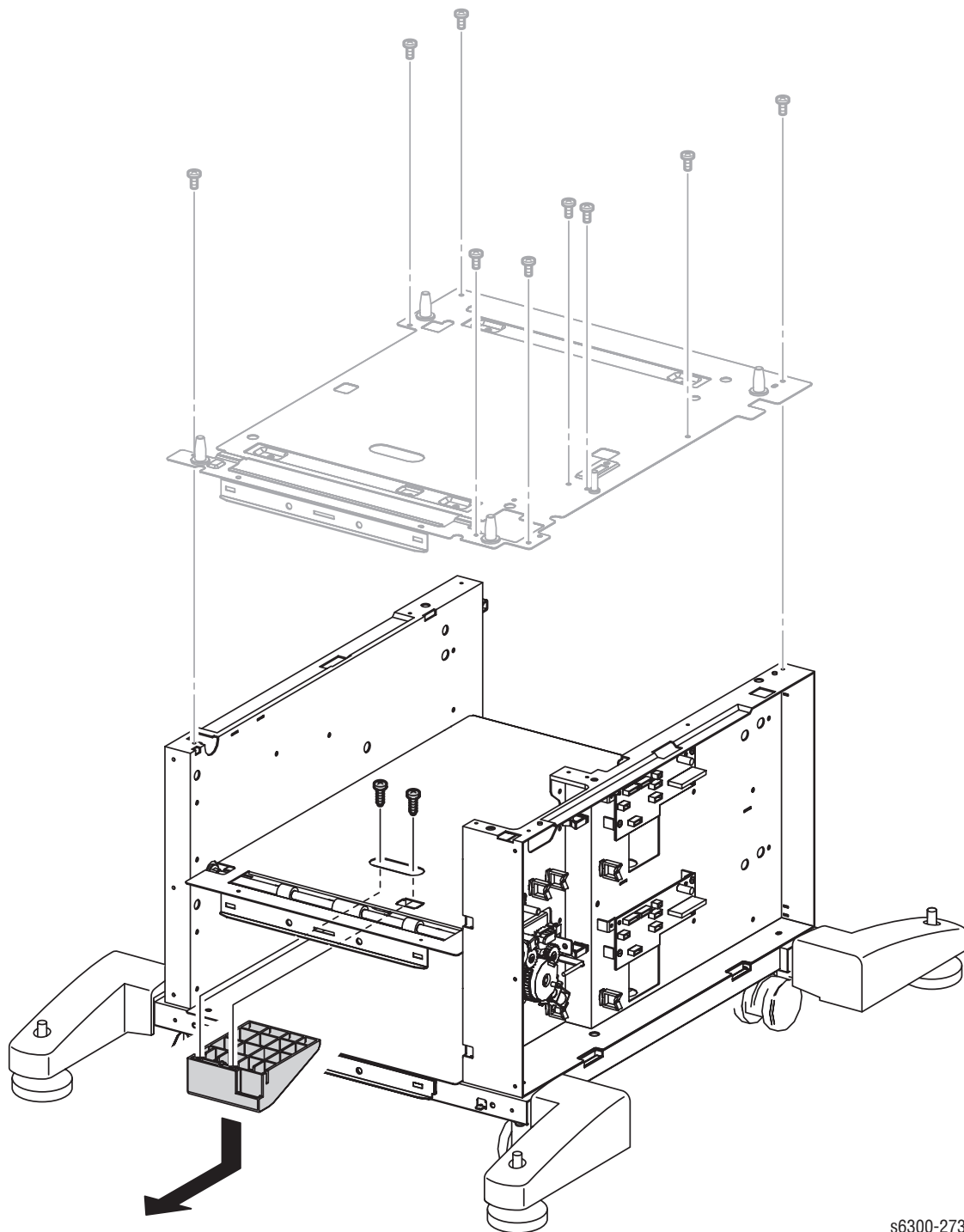

s6300-273

4. Disconnect the connector (P/J81) from the lower Circuit Board HCF, and remove the harness from clamp.
5. Disconnect the No Paper Sensor connector (P/J822) on Paper Pick Assembly HCF T2.
6. Disconnect the Feed Solenoid connector (P/J824) and remove the harness from the clamp.
7. Disconnect the Turn Roller Clutch connector (P/J825) and remove the harness from the clamp.

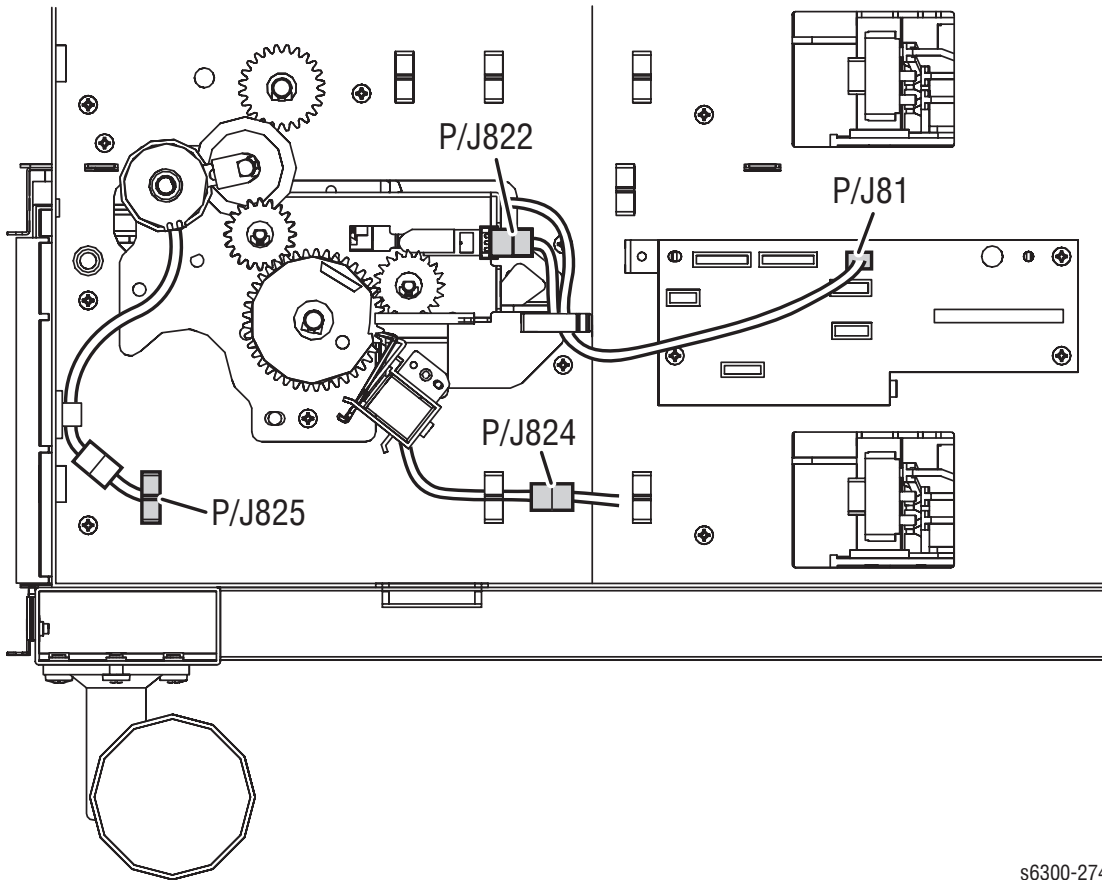

s6300-274

- 18.** Remove three screws (metal, 6 mm) that secure the Paper Pick Assembly HCF T2 to the frame, and remove the Paper Pick Assembly HCF T2 from the right.

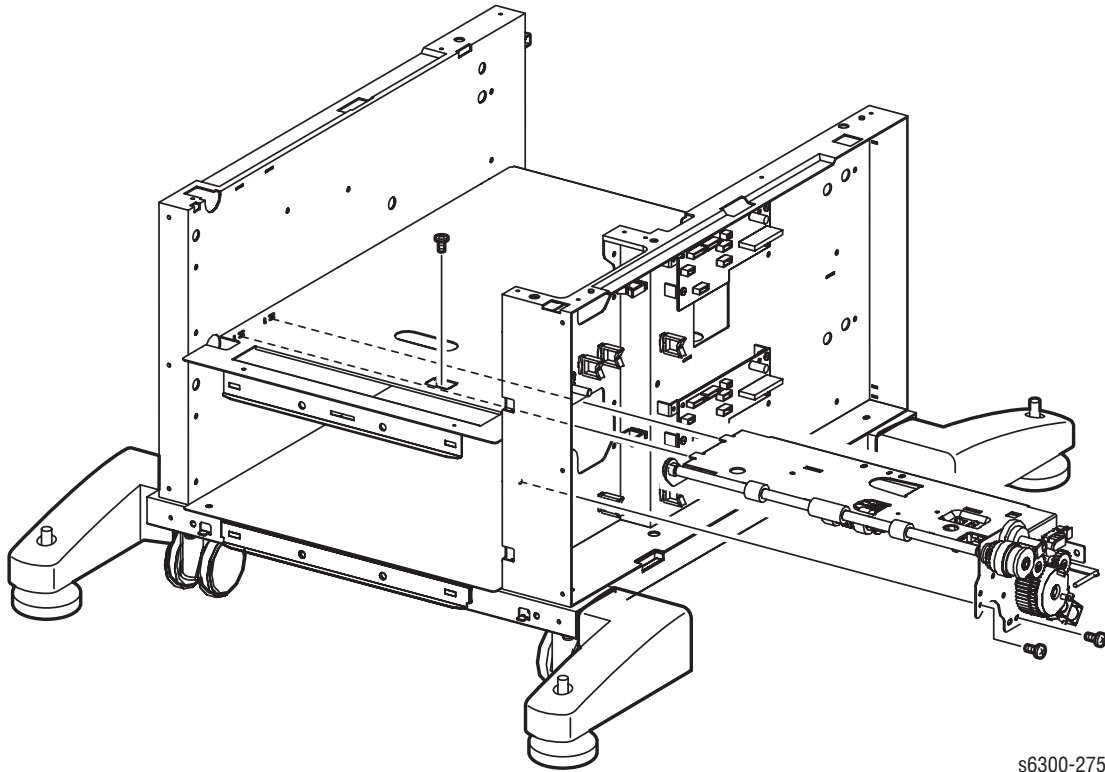

s6300-275

No Paper Sensor (PL12.5.7)

1. Remove the Front Covers (page 8-111).
2. Remove the Right Cover (page 8-113).
3. Disconnect the No Paper Sensor connector (P/J822).
4. Lift the actuator and use a small screwdriver to release the 3 hooks and remove the No Paper Sensor.

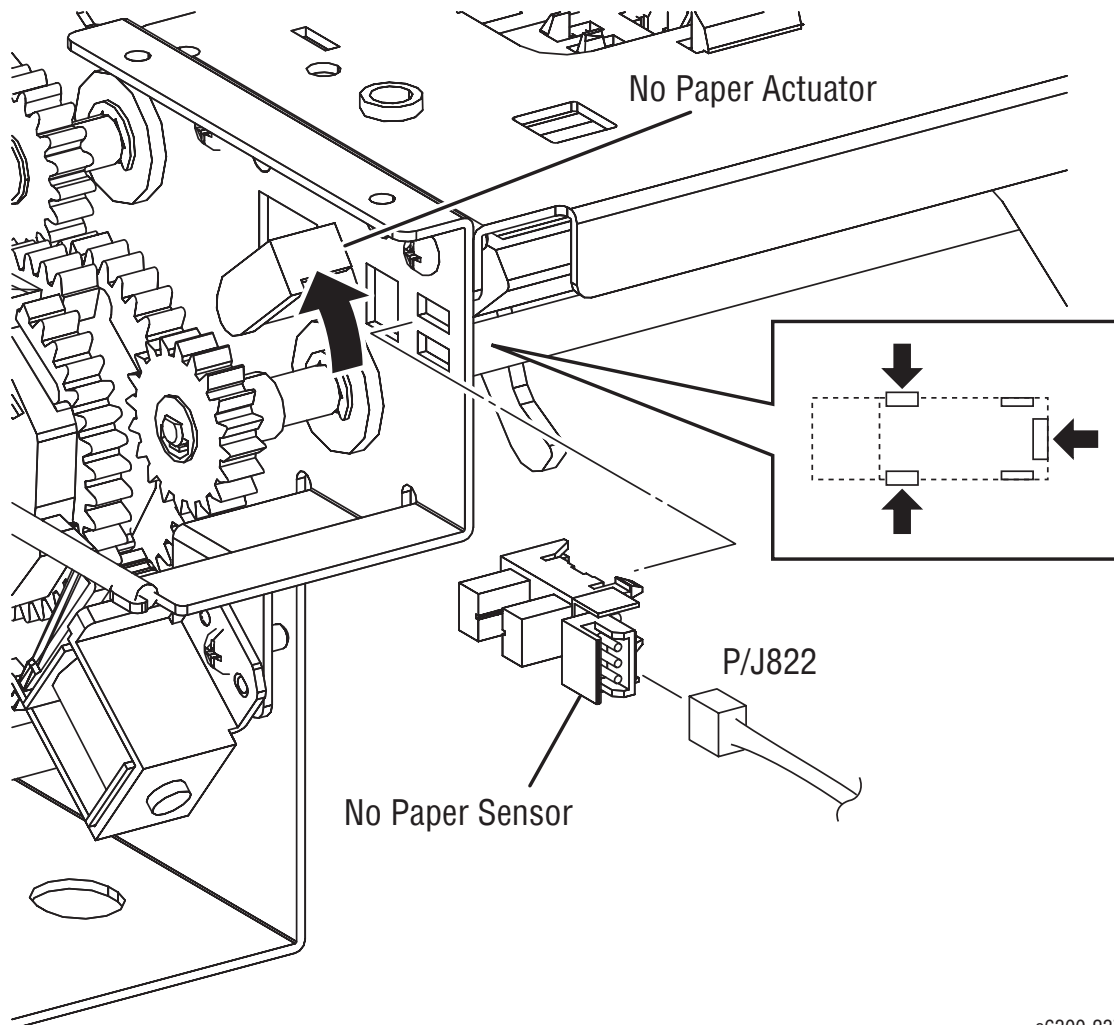

s6300-237

Low Paper Sensor (PL12.5.7)

1. Remove the Paper Pick Assembly (page 8-122).
2. Disconnect the Low Paper Sensor connector (P/J823).
3. Release the 3 hooks on the Low Paper Sensor and remove the sensor.

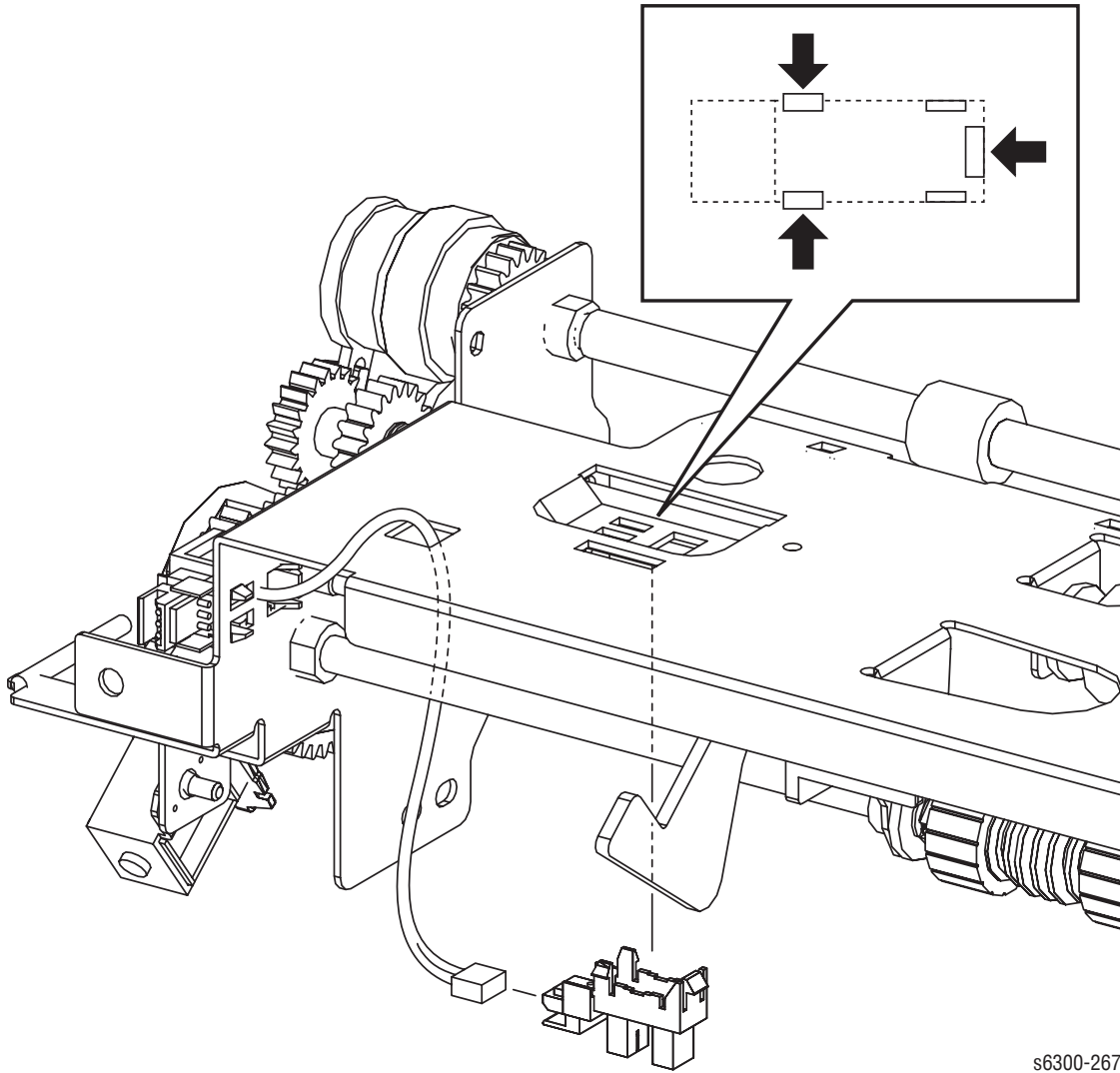

s6300-267

Low Paper Sensor Actuator (PL12.5.14)

1. Remove the Upper Chute (page 8-30).
2. Turn over the Upper Chute.
3. Release the hook of Upper Chute that secures the Low Paper Sensor Actuator and move the shaft on one side to remove the actuator.

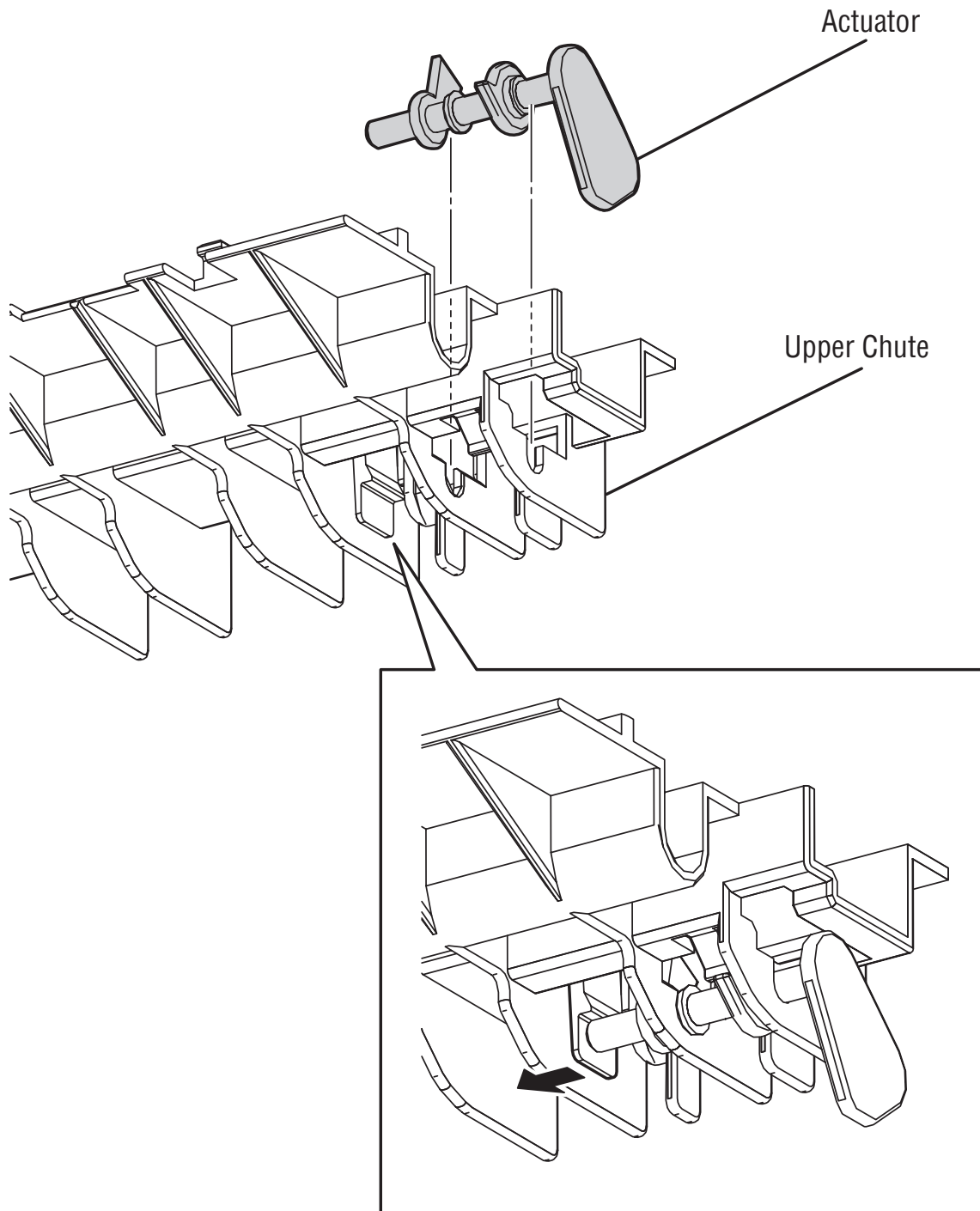

s6300-150

Feed Rollers (PL12.4.19)

1. Remove the tray from the printer.
2. Release the lock that fixes each Feed Roller to the shaft and remove the roller.

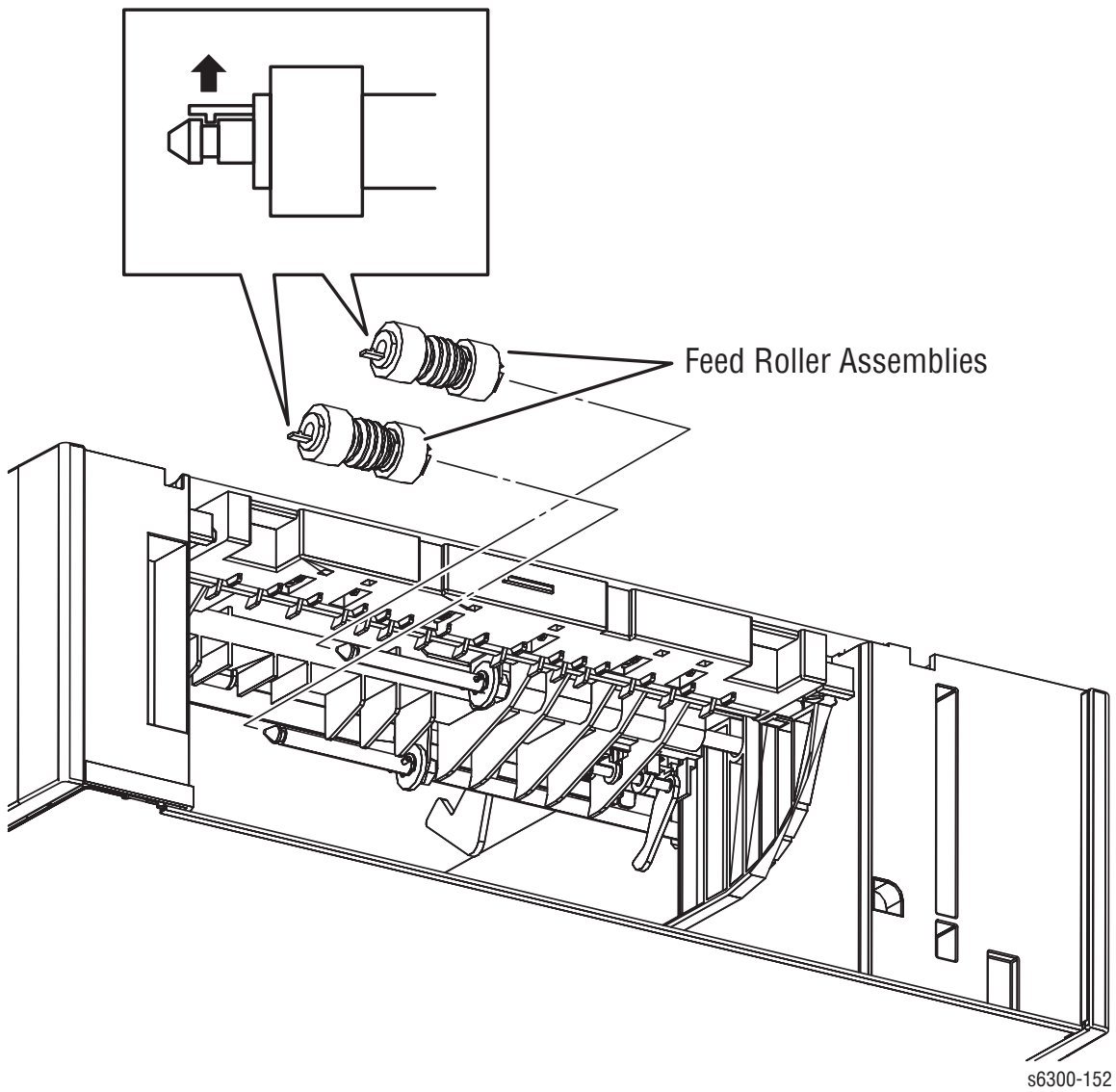

No Paper Sensor Actuator (PL12.5.20)

1. Remove the Paper Pick Assembly (page 8-122).
2. Release the hook that secures the No Paper Sensor Actuator to the Paper Pick Assembly.
3. Push the actuator shaft slightly away from the sensor to move the shaft to the larger opening in the slot.
4. Remove the actuator out of the slot of Paper Pick Assembly while moving the hook side of actuator toward you.

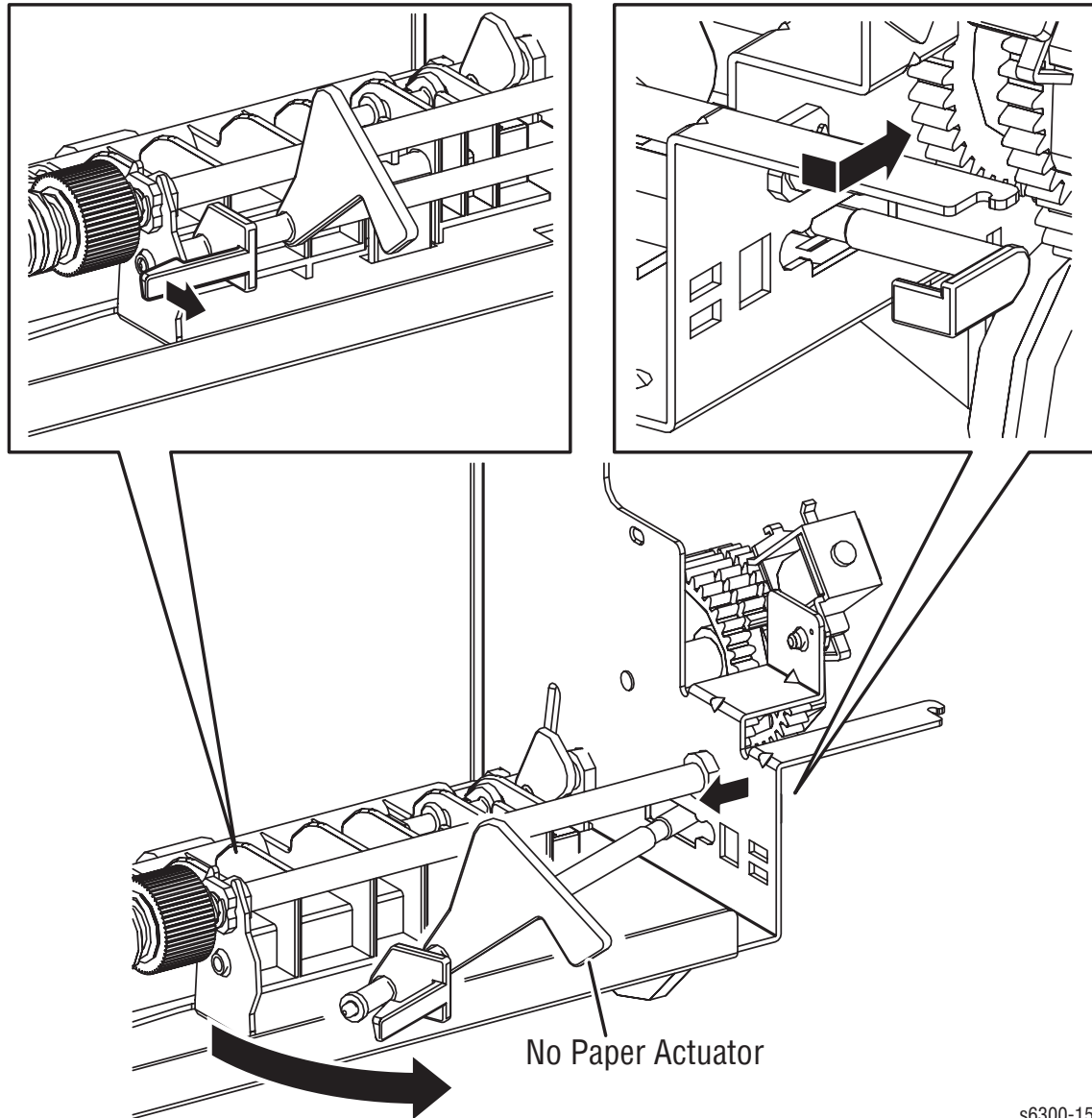

s6300-153

Retard Roller Assembly (PL12.6.13)

1. Remove the tray.
2. Release the 2 hooks at the left and right of the Turn Chute by pushing inward and open the chute.
3. Rotate the Retard Holder 90 degrees.
4. Slide the Retard Roller Assembly to the left and remove it from the 2 bosses, and then lift it upward.

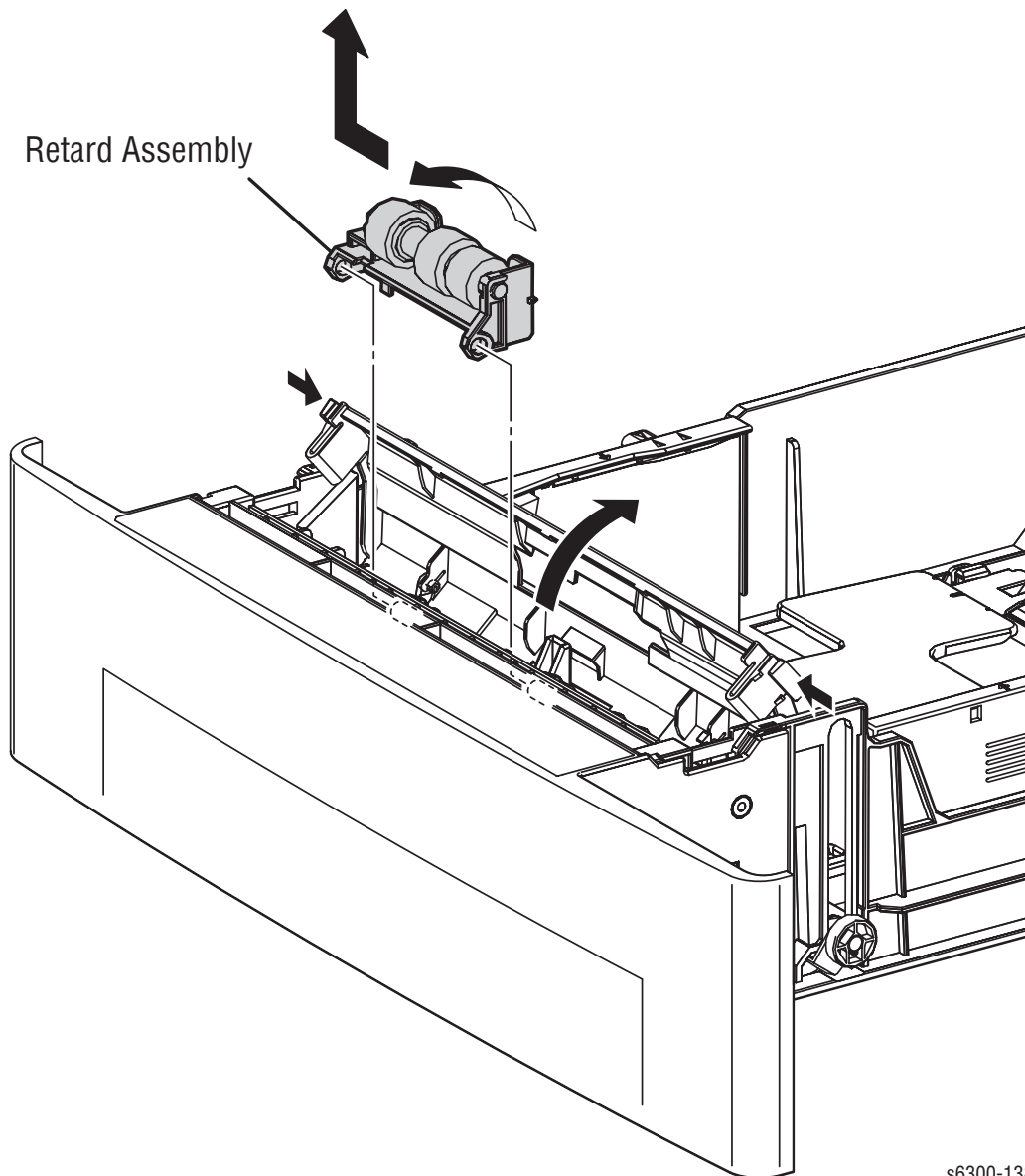

s6300-138

Optional 550-Sheet Feeder Disassembly

Docking (PL11.1.1)

Caution

Lifting the printer requires two people. Use care when removing the printer from the Feeder.

1. Remove Tray 2.
2. Remove four screws that secure the Tray 3 Feeder to the printer.
3. Lift the printer from the Tray 3 Feeder.

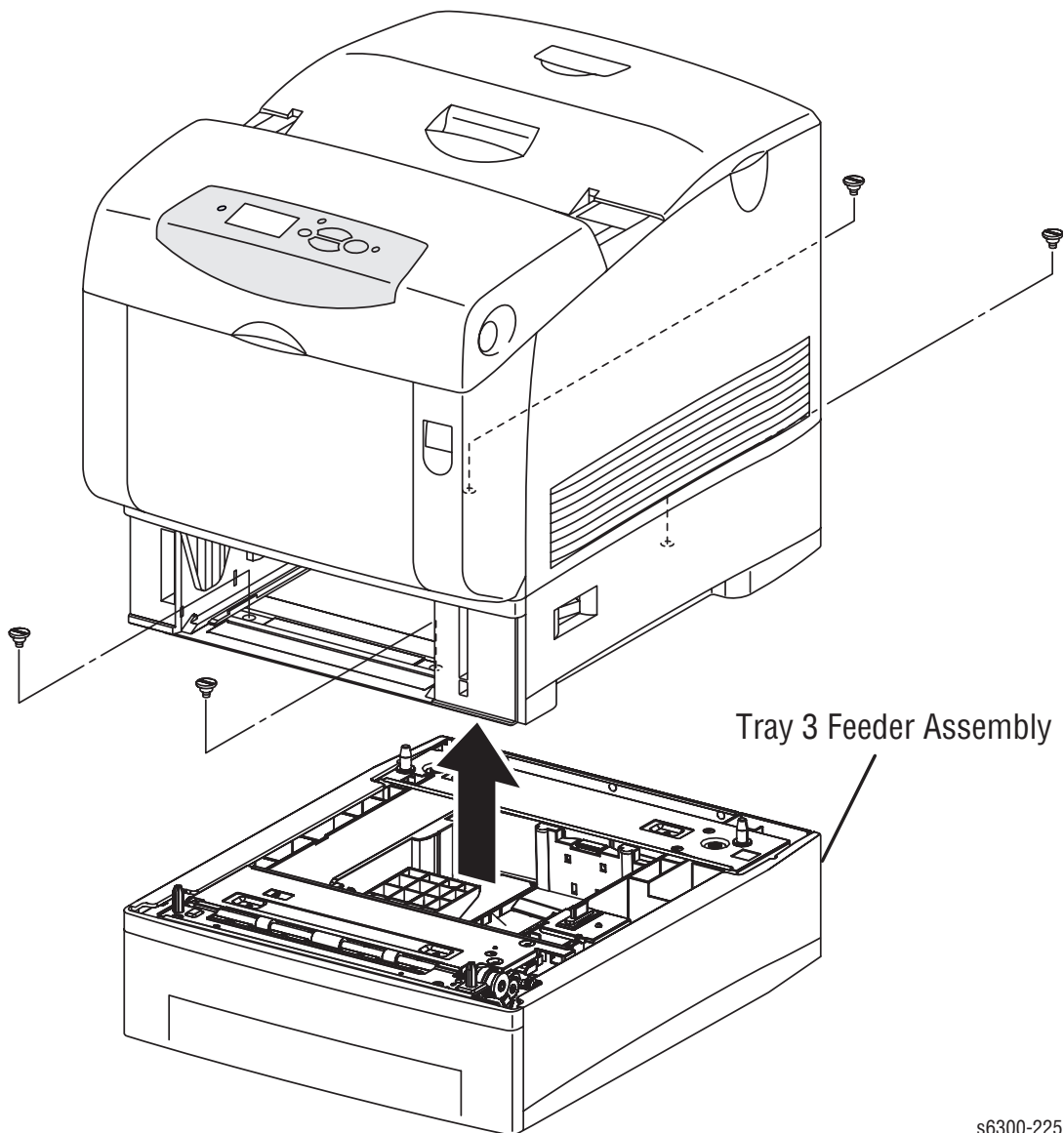

s6300-225

Right Cover (PL11.1.11)

1. Remove Tray 3 from the printer.
2. Remove 2 screws (self-tapping, flanged, plastic, 8mm) that secure the Right Cover.
3. Release two hooks at the rear to remove the Right Cover.

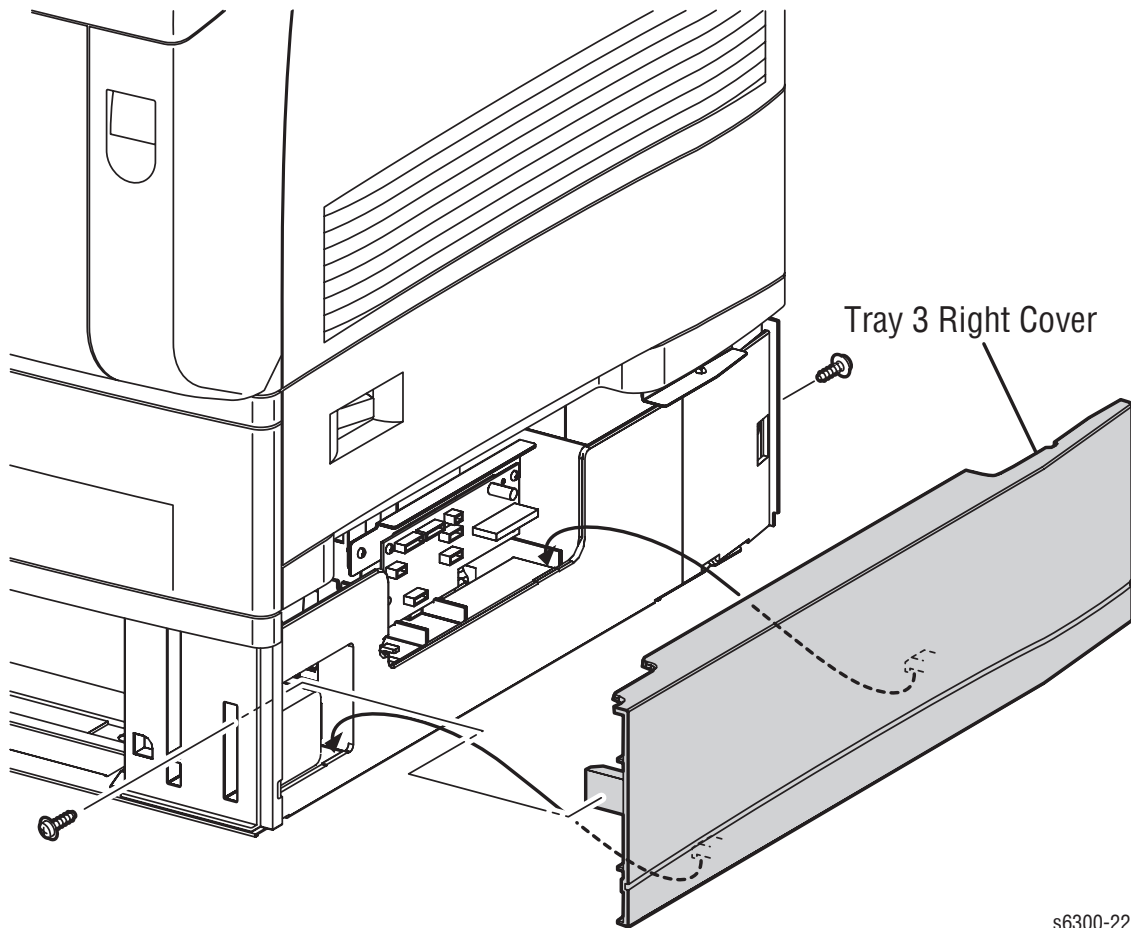

s6300-228

Left Cover (PL11.1.7)

1. Remove Tray 3 from the printer.
2. Remove 2 screws (self-tapping, flanged, plastic, 8mm) that secure the Left Cover.
3. Release two hooks at the rear and remove the cover.

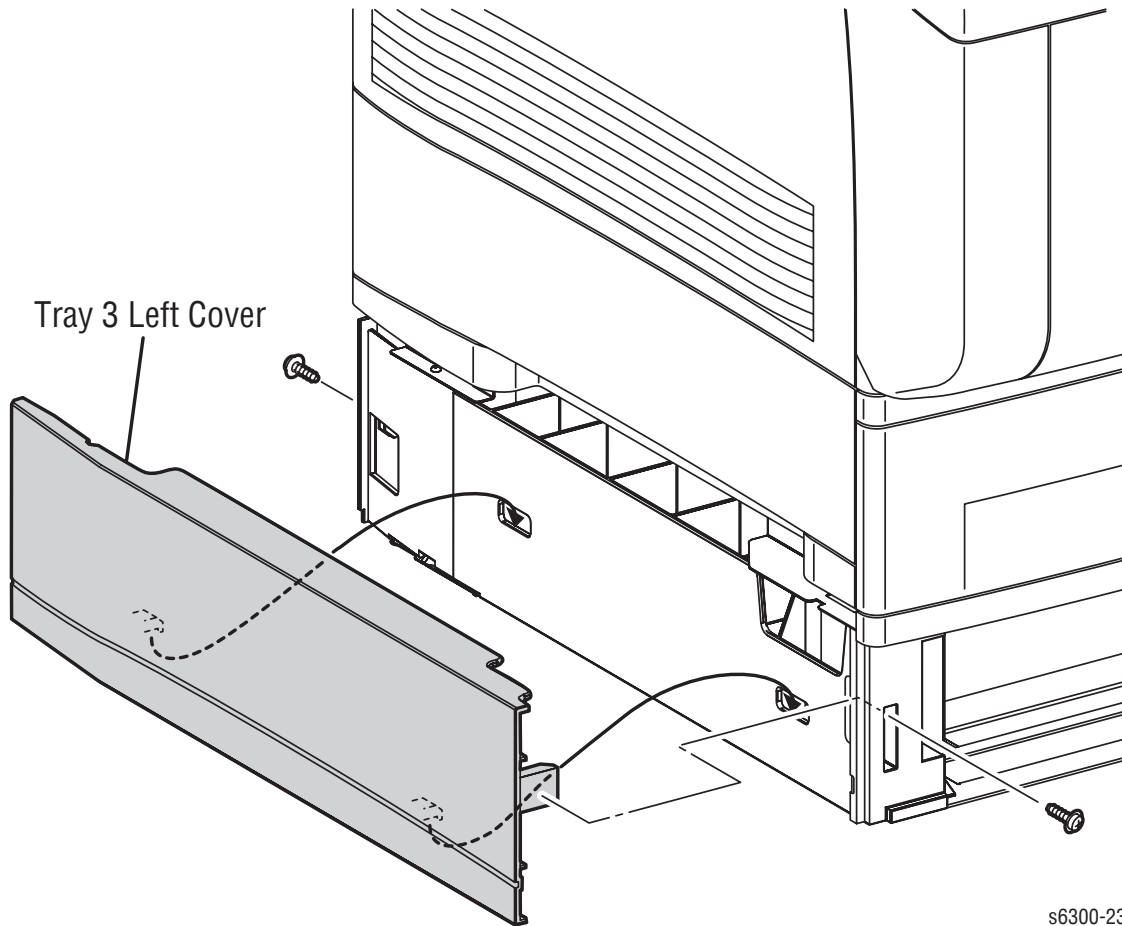

s6300-231

OPTFDR 1 Harness (PL11.1.6)

1. Remove the 550-Sheet Feeder (page 8-134).
2. Remove the Right Cover (page 8-135).
3. Remove the screw (metal, 6 mm) in the Connector Plate and the screw in the OPTFDR 1 Board.
4. Remove the assembly from the Feeder.
5. Disconnect the harness (P/J83) from the OPTFDR 1 Board.
6. Release two hooks that hold the OPTFDR 1 Harness from the rear side of Connector Plate, and remove the harness.

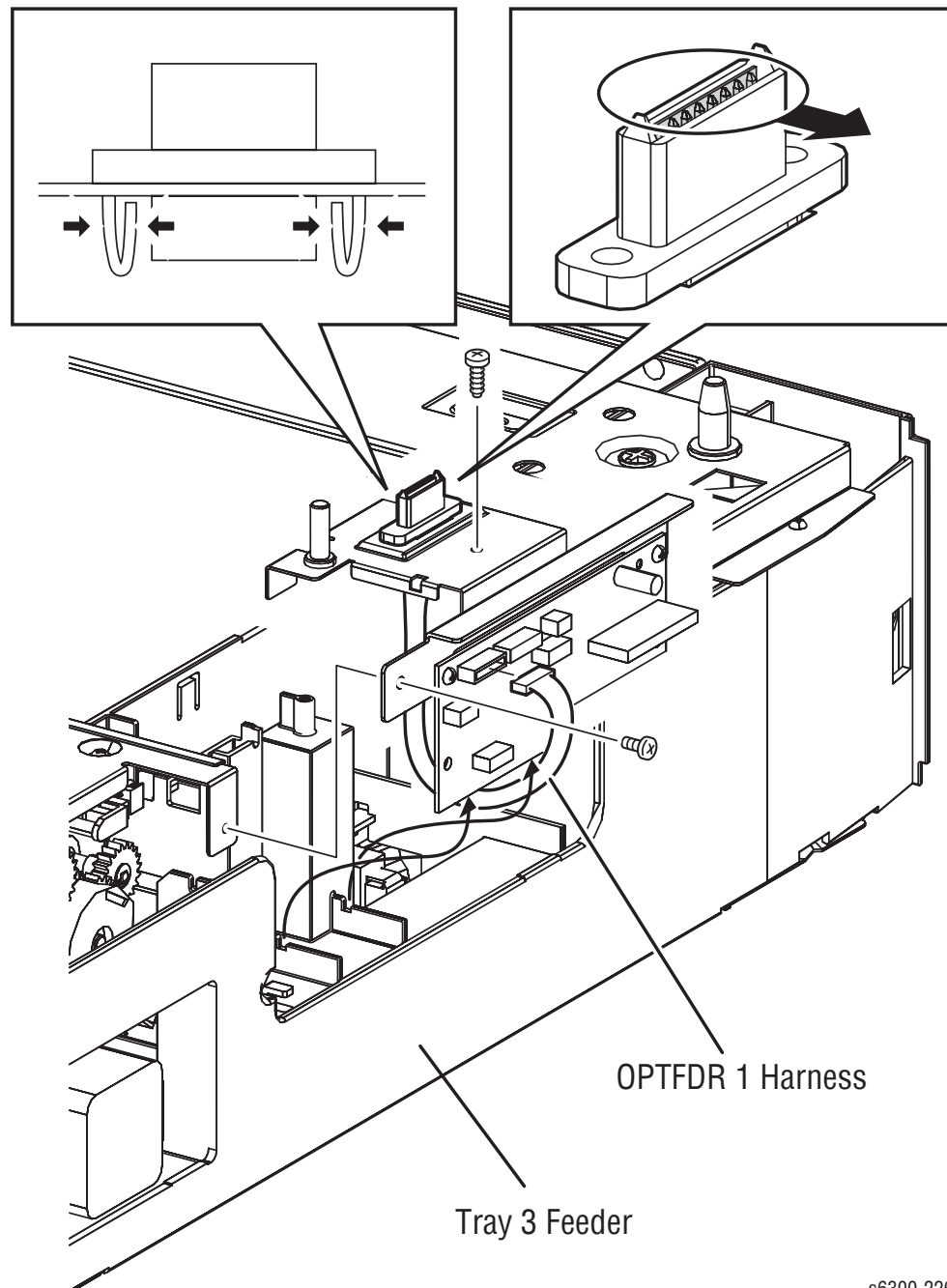

s6300-226

Circuit Board LTA (PL11.1.10)

- 1. Remove the Right Cover (page 8-135).
- 2. Remove all connectors on the OPTFDR 1 Board.
- 3. Remove 2 screws (metal, 6 mm) the secure the OPTFDR 1 Board to the bracket.
- 4. Remove OPTFDR 1 Board from the notches in the Feeder frame.

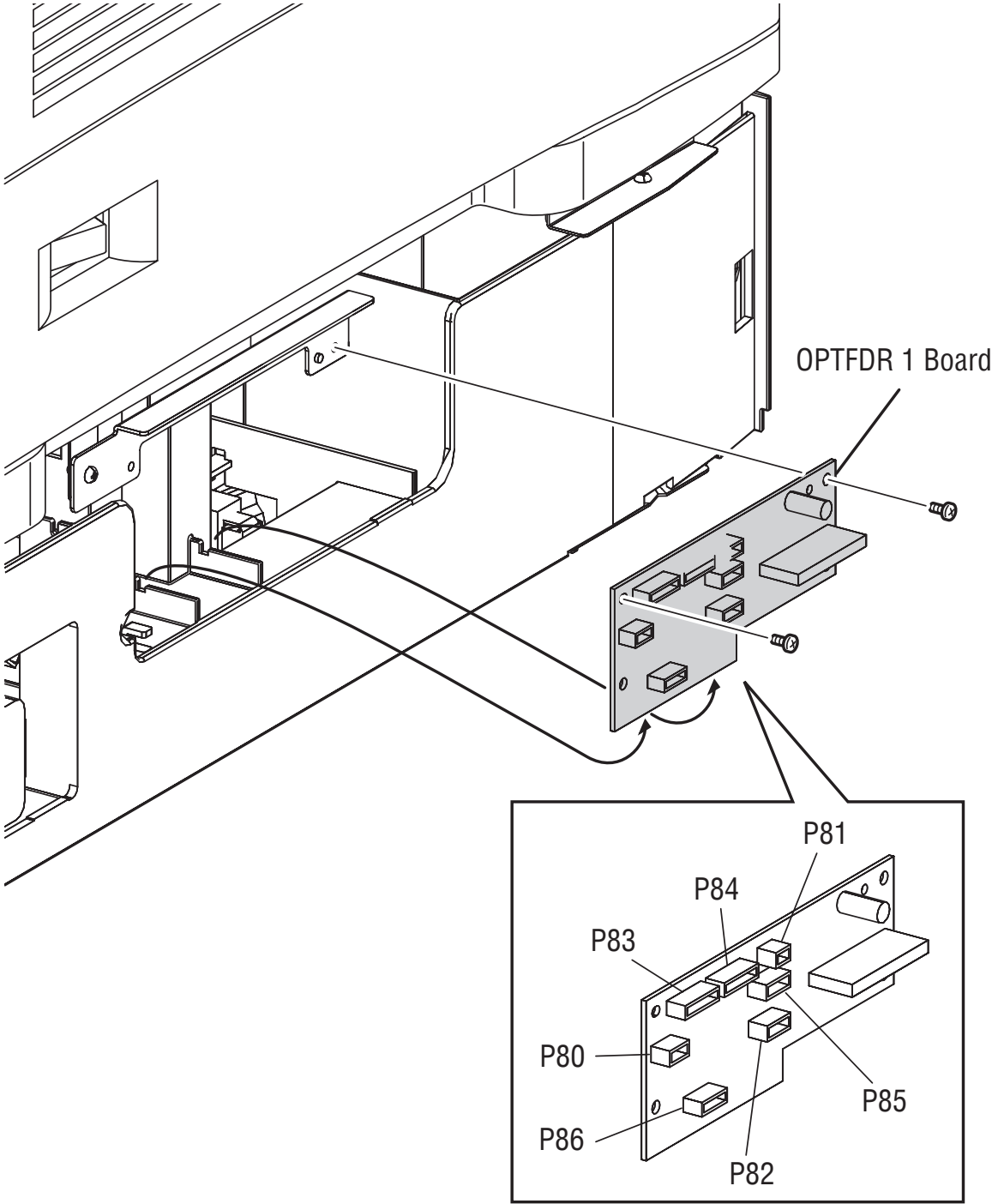

OPTPLG 2 Harness (PL11.1.13)

1. Remove the 550-Sheet Feeder (page 8-134).
2. Remove the Right Cover (page 8-135).
3. Remove the screw (metal, 6 mm) in the Connector Plate and the screw (self-tapping, plastic 8 mm) in the OPTFDR 1 Board.
4. Remove the assembly from the Feeder.
5. Remove the OPTPLG 2 Harness connector (P/J84) from OPTFDR 1 Board.
6. Release the hooks, at two positions, securing the option plug to the frame.

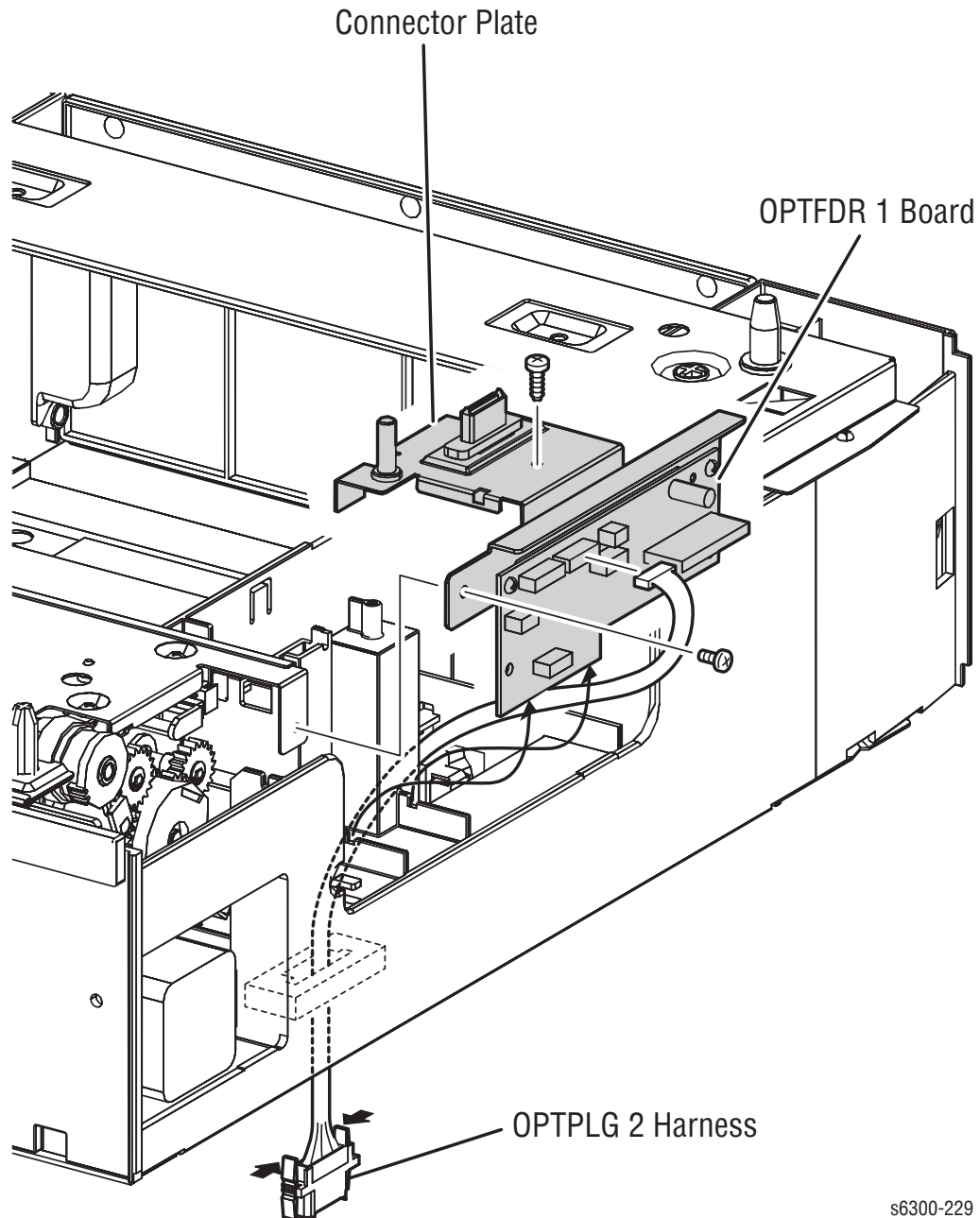

s6300-229

Paper Size Switch (PL11.2.6)

1. Remove the 550-Sheet Feeder (page 8-134).
2. Disconnect the Paper Size Switch connector (P/J821).
3. Remove a screw (self-tapping, plastic 8 mm) that secures the Paper Size Switch to the Right Feeder and remove the switch.

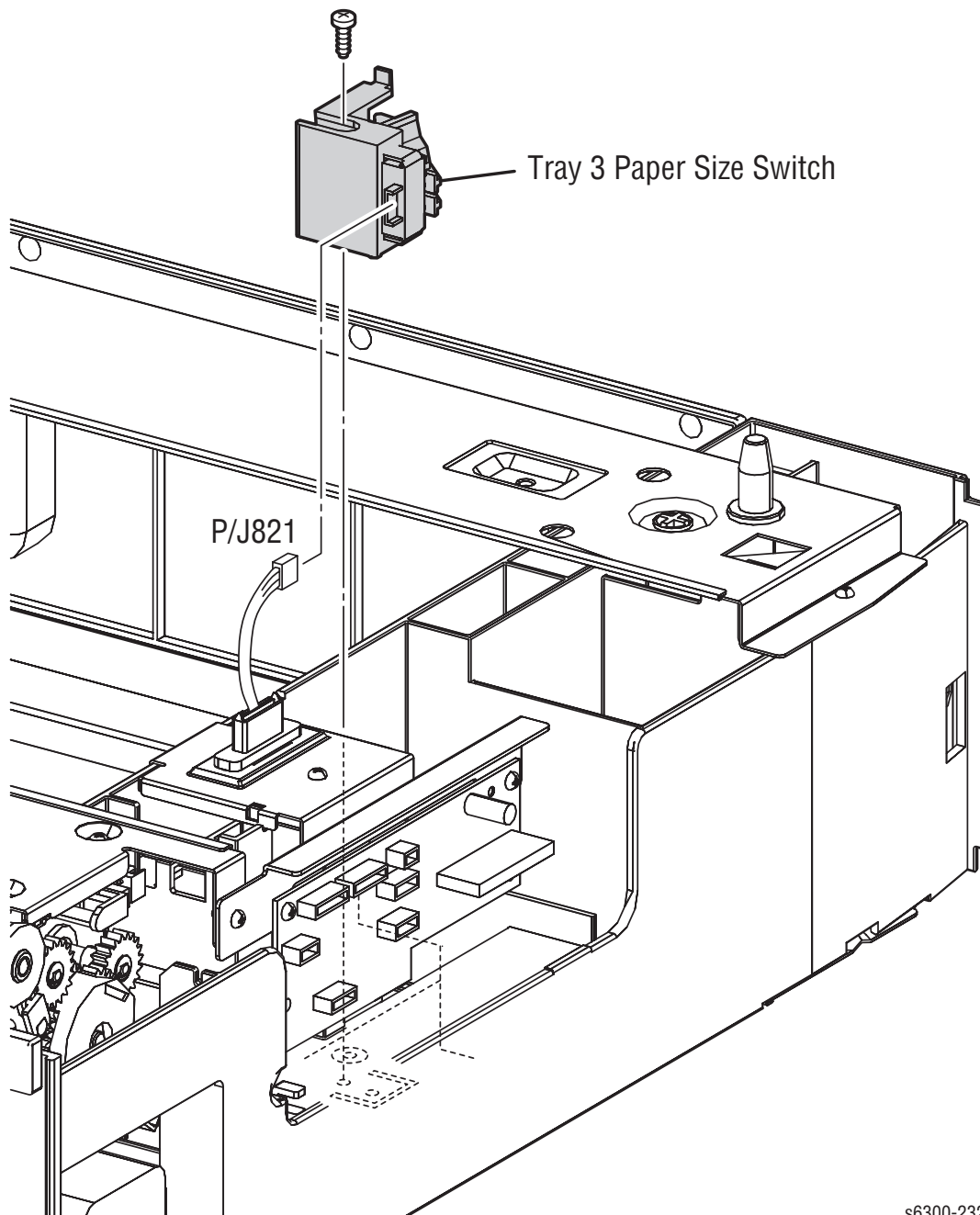

s6300-232

Paper Pick Assembly (PL11.3.1)

1. Remove the 550-Sheet Feeder (page 8-134).
2. Remove the Right Cover (page 8-135).
3. Remove the Left Cover (page 8-136).
4. Remove the Drive Assembly (page 8-146).
5. Remove two long screws and five short screws (metal, 6 mm) that secure the Top Frame Assembly, and remove it from the Feeder.

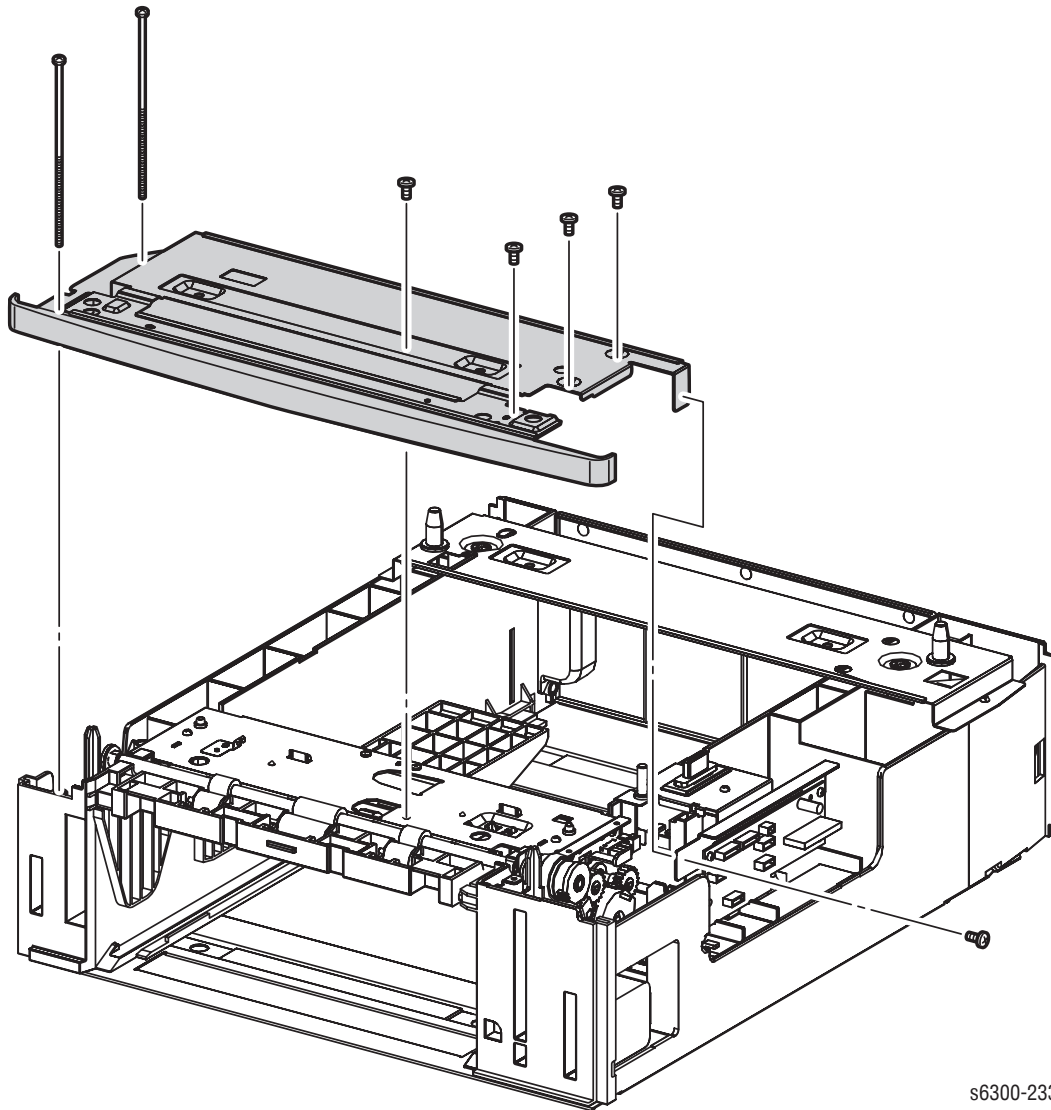

s6300-233

6. Remove the sensor connectors (P/J81, P/J85) on the OPTFDR 1 Board.
7. Remove 4 screws (self-tapping, plastic 8 mm) that secures the Paper Pick Assembly to the Feeder.

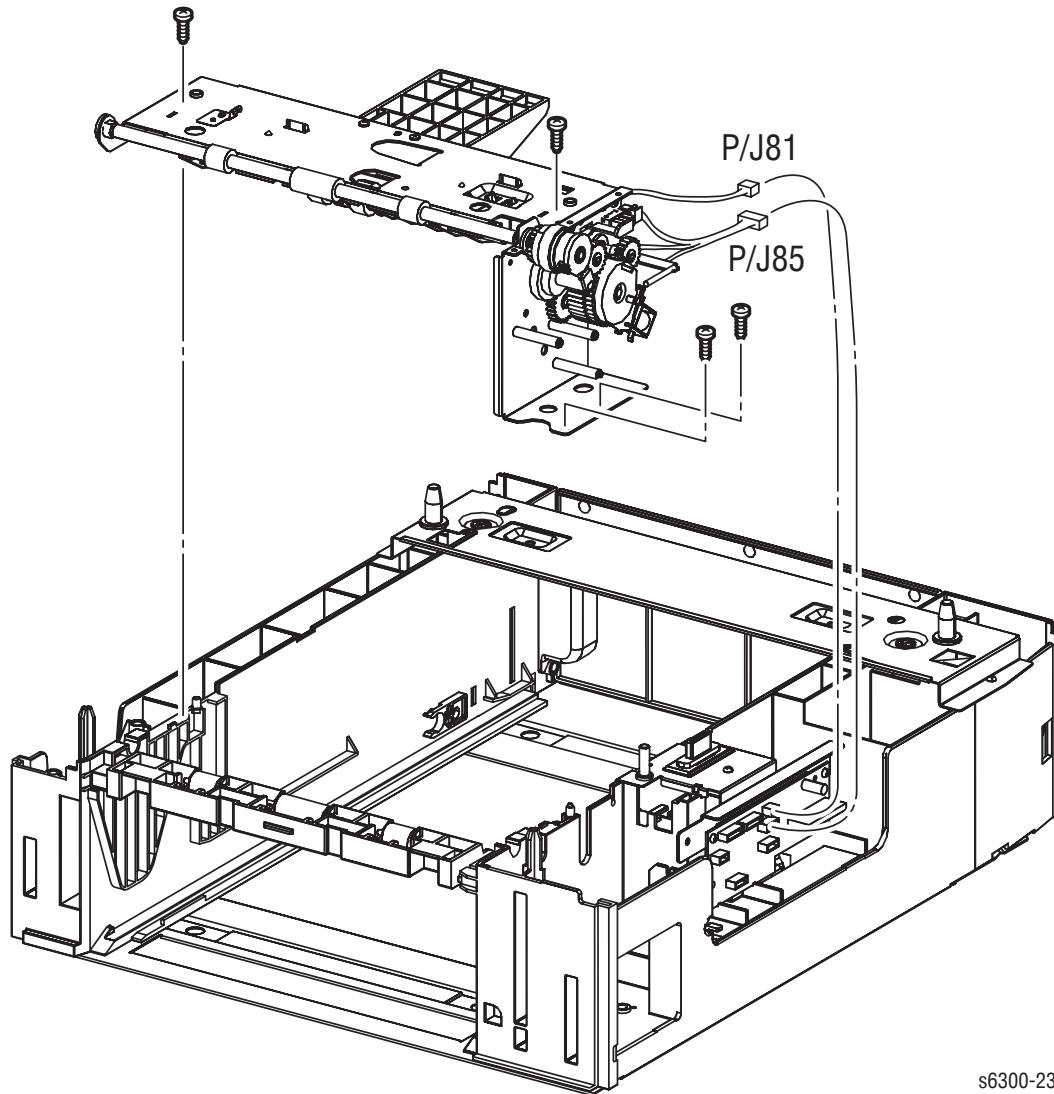

s6300-234

No Paper Sensor (PL11.3.7)

1. Remove the 550-Sheet Feeder (page 8-134).
2. Remove the Right Cover (page 8-135).
3. Remove the Left Cover (page 8-136).
4. Remove the Drive Assembly (page 8-146).
5. Remove Paper Pick Assembly (page 8-141).
6. Disconnect the No Paper Sensor connector (P/J822).
7. Lift the No Paper Sensor Actuator and release the three hooks to remove the sensor.

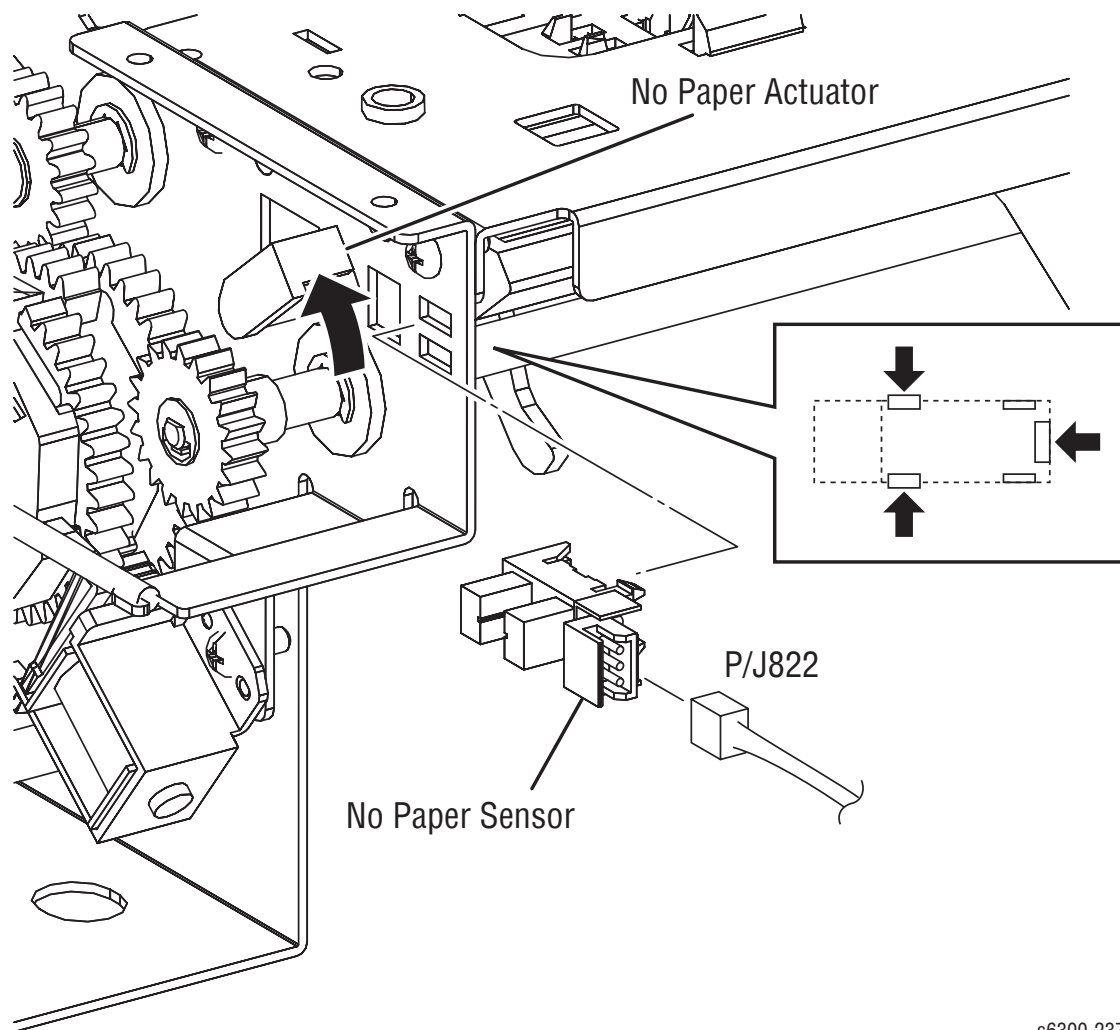

s6300-237

Low Paper Sensor (PL11.3.7)

1. Remove the 550-Sheet Feeder (page 8-134).
2. Remove the Right Cover (page 8-135).
3. Remove the Left Cover (page 8-136).
4. Remove the Upper Chute (page 8-30).
5. Remove two long screws and five short screws (metal, 6 mm) that secure the Top Frame Assembly, and remove it from the Feeder.

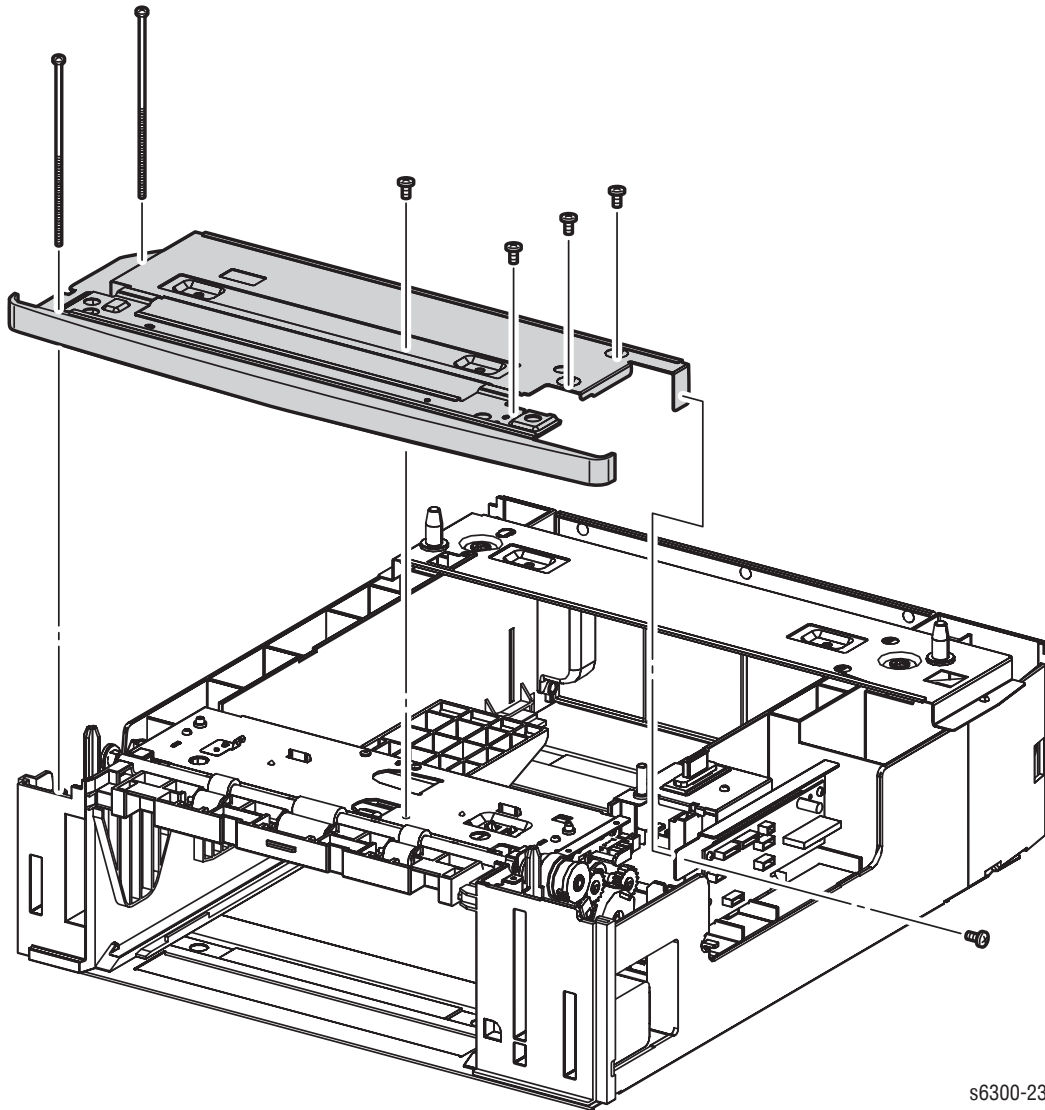

s6300-233

6. Disconnect the Low Paper Sensor connector (P/J823).
7. Release the three hooks and remove the Low Paper Sensor.

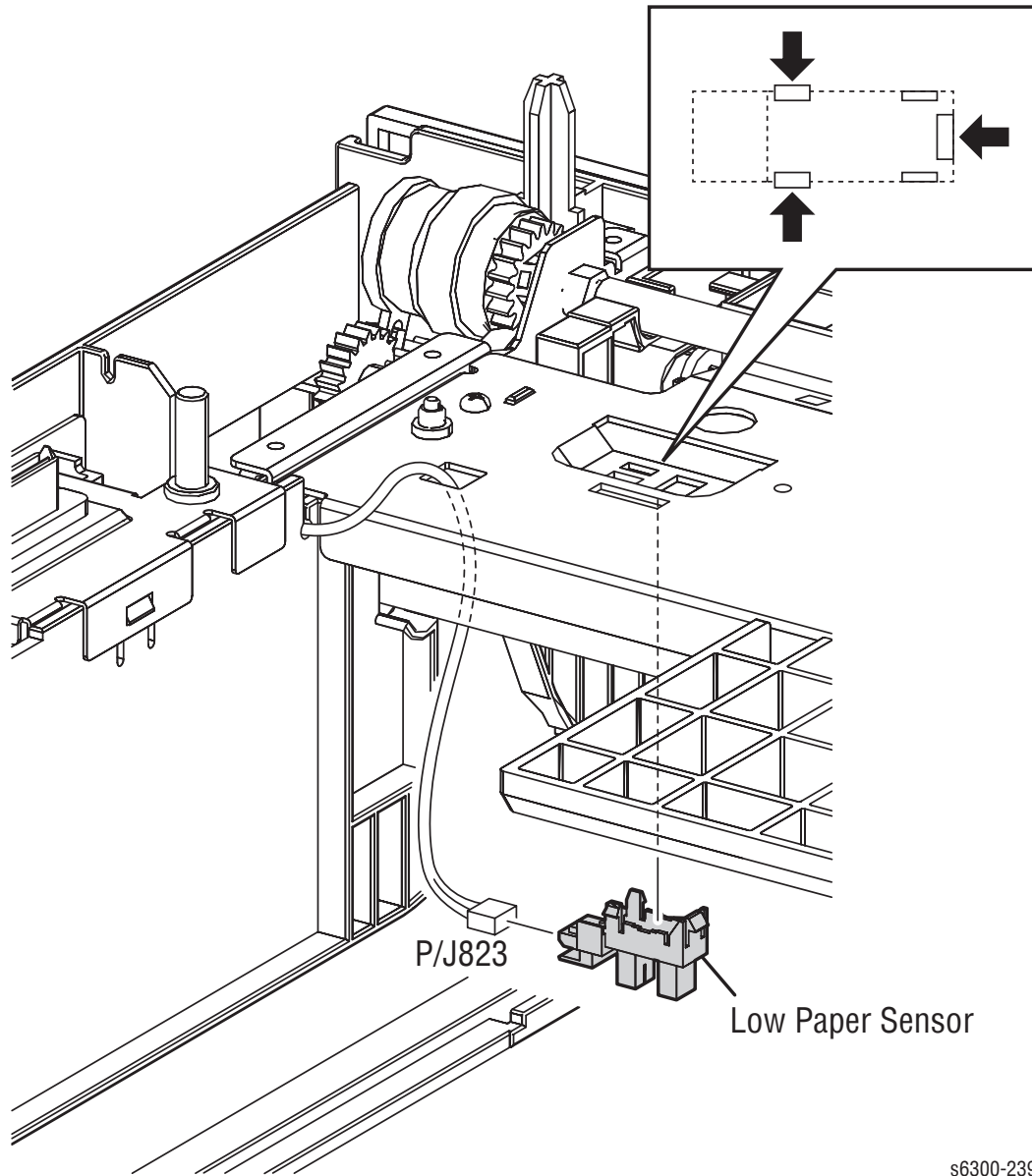

s6300-239

Drive Assembly (PL11.3.15)

1. Remove the Right Cover (page 8-135).
2. Disconnect the Drive Assembly connector (P/J82) from the OPTFDR 1 Board.
3. Remove the Drive Assembly harness from the harness guides.
4. Remove 3 screws (metal, 6 mm) that secure the Drive Assembly to the frame.

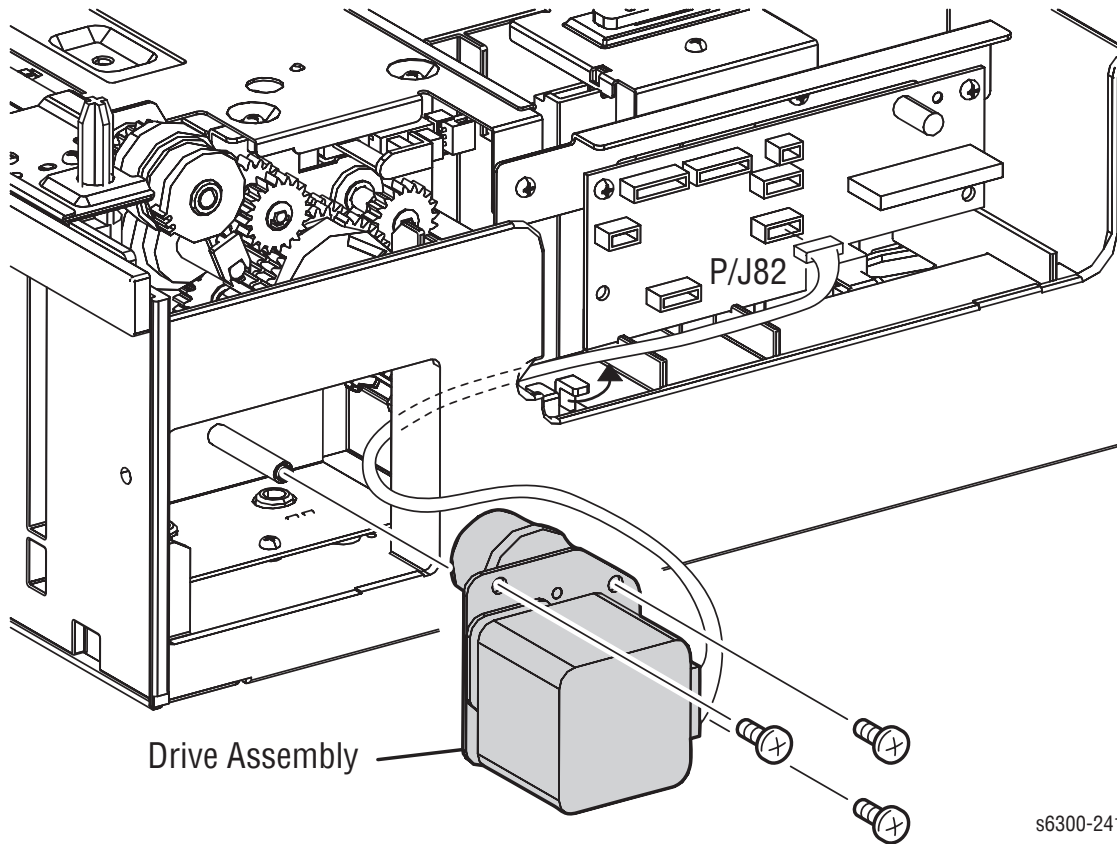

Low Paper Sensor Actuator (PL11.3.16)

1. Remove the Upper Chute (page 8-30).
2. Turn over Upper Chute.
3. Release the hook that secures the Low Paper Sensor Actuator and remove the end of the actuator shaft from the Upper Chute.

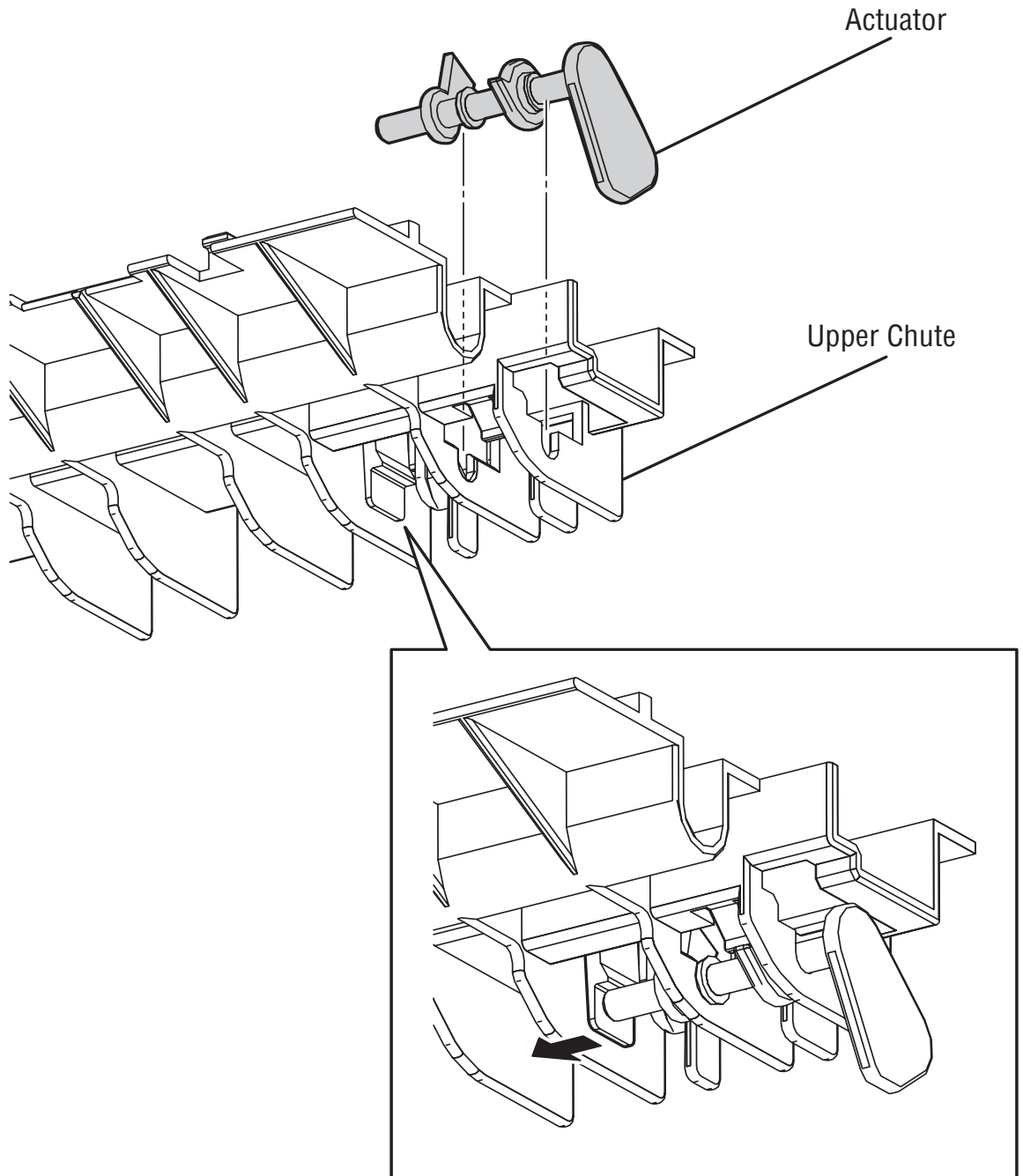

s6300-150

Feed Rollers (PL11.3.20)

1. Remove the tray from the printer.
2. Release the lock that fixes Nudger Roller to the shaft and remove the Nudger Roller.

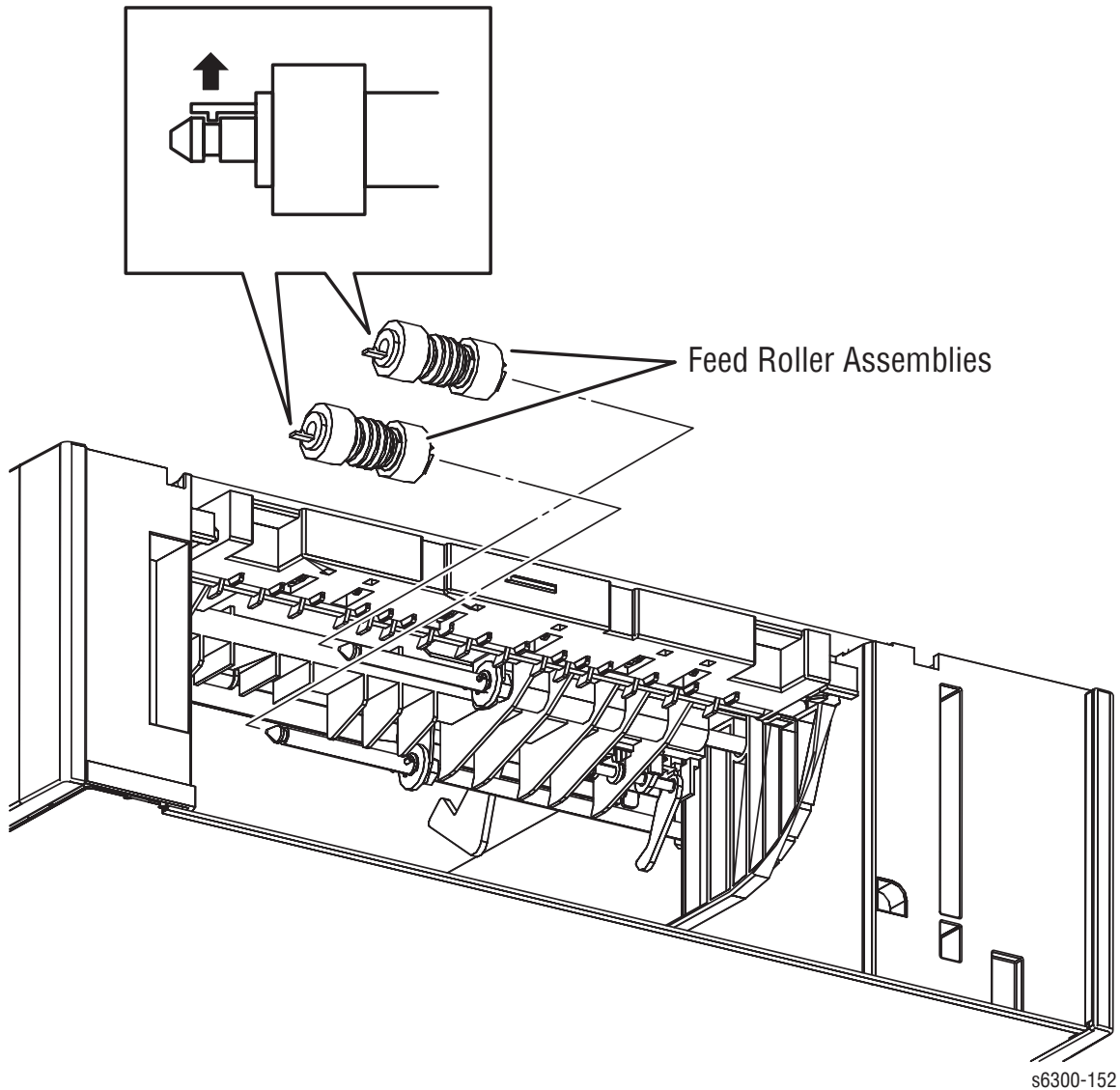

No Paper Sensor Actuator (PL11.3.22)

1. Remove the 550-Sheet Feeder (page 8-134).
2. Remove the Right Cover (page 8-135).
3. Remove the Left Cover (page 8-136).
4. Remove the Drive Assembly (page 8-146).
5. Remove Paper Pick Assembly (page 8-141).
6. Remove 2 screws (self-tapping, plastic 8 mm) that secure the Paper Guide to the Paper Pick Assembly.

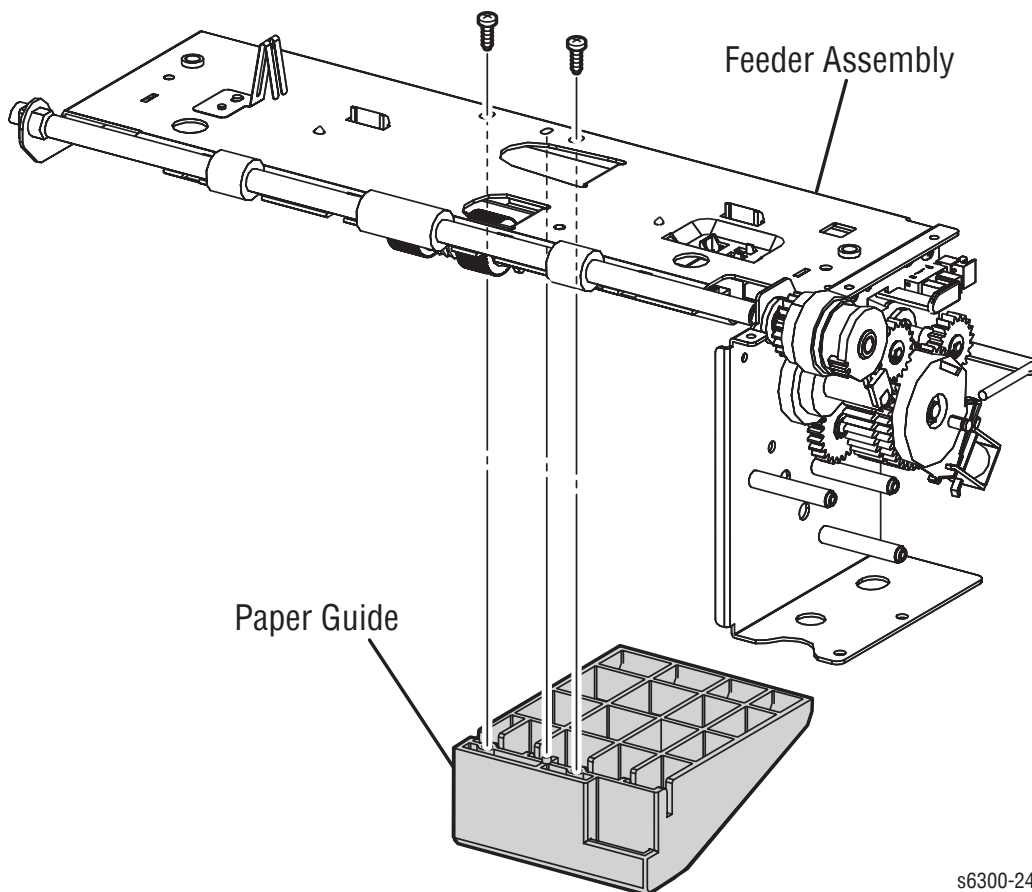

s6300-245

7. Turn over the Paper Pick Assembly.
8. Release the hook that secures the No Paper Sensor Actuator to the Paper Pick Assembly.
9. Push the actuator shaft slightly away from the sensor to move the shaft to the larger opening in the slot.
10. Remove the actuator out of the slot of Paper Pick Assembly while moving the hook side of actuator toward you.

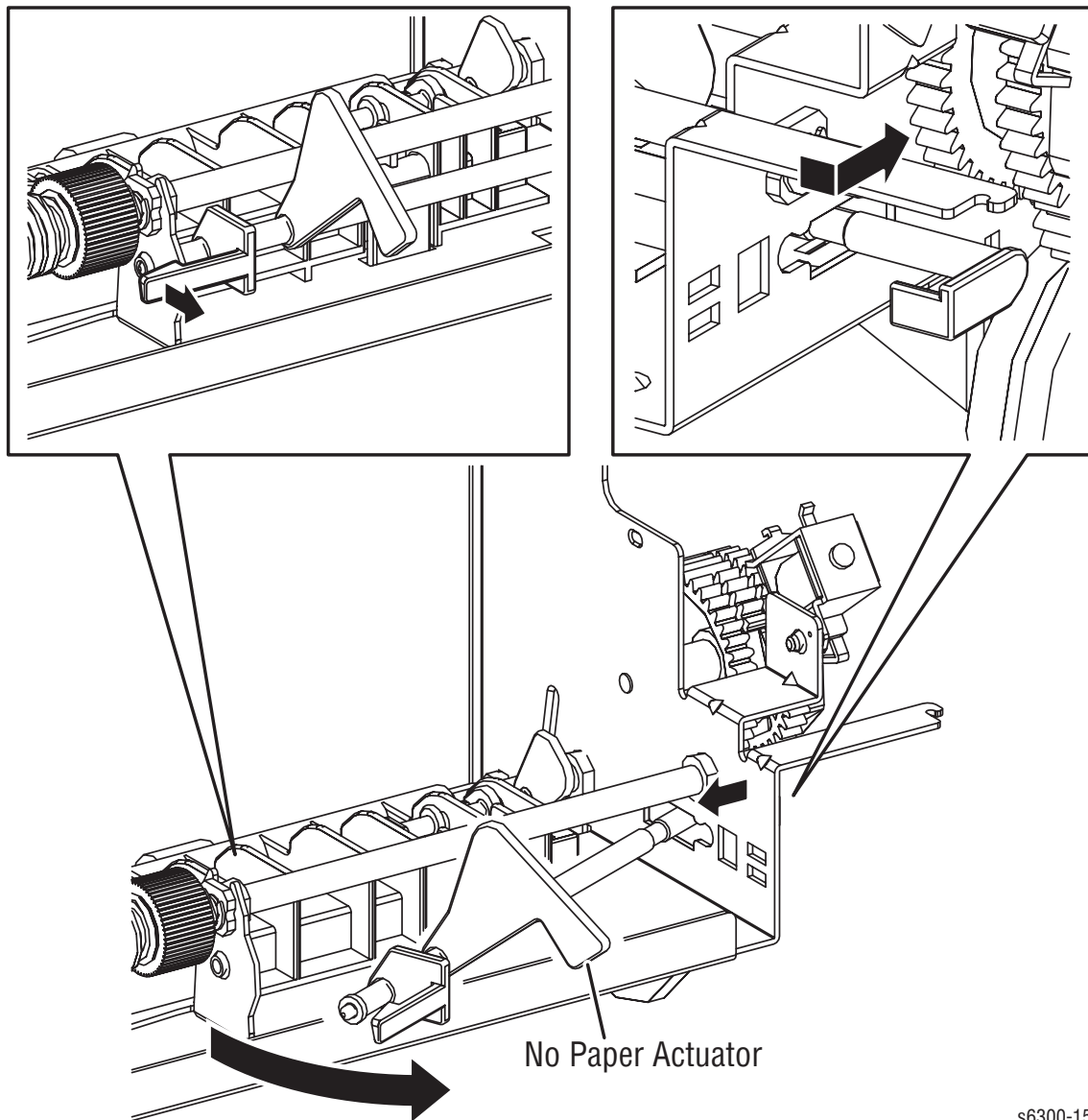

s6300-153

Retard Roller Assembly (PL11.4.12)

1. Remove the tray.
2. Release the 2 hooks at the left and right of the Turn Chute by pushing inward and open the chute.
3. Rotate the Retard Holder 90 degrees.
4. Slide the Retard Roller Assembly to the left and remove it from the 2 bosses, and then lift it upward.

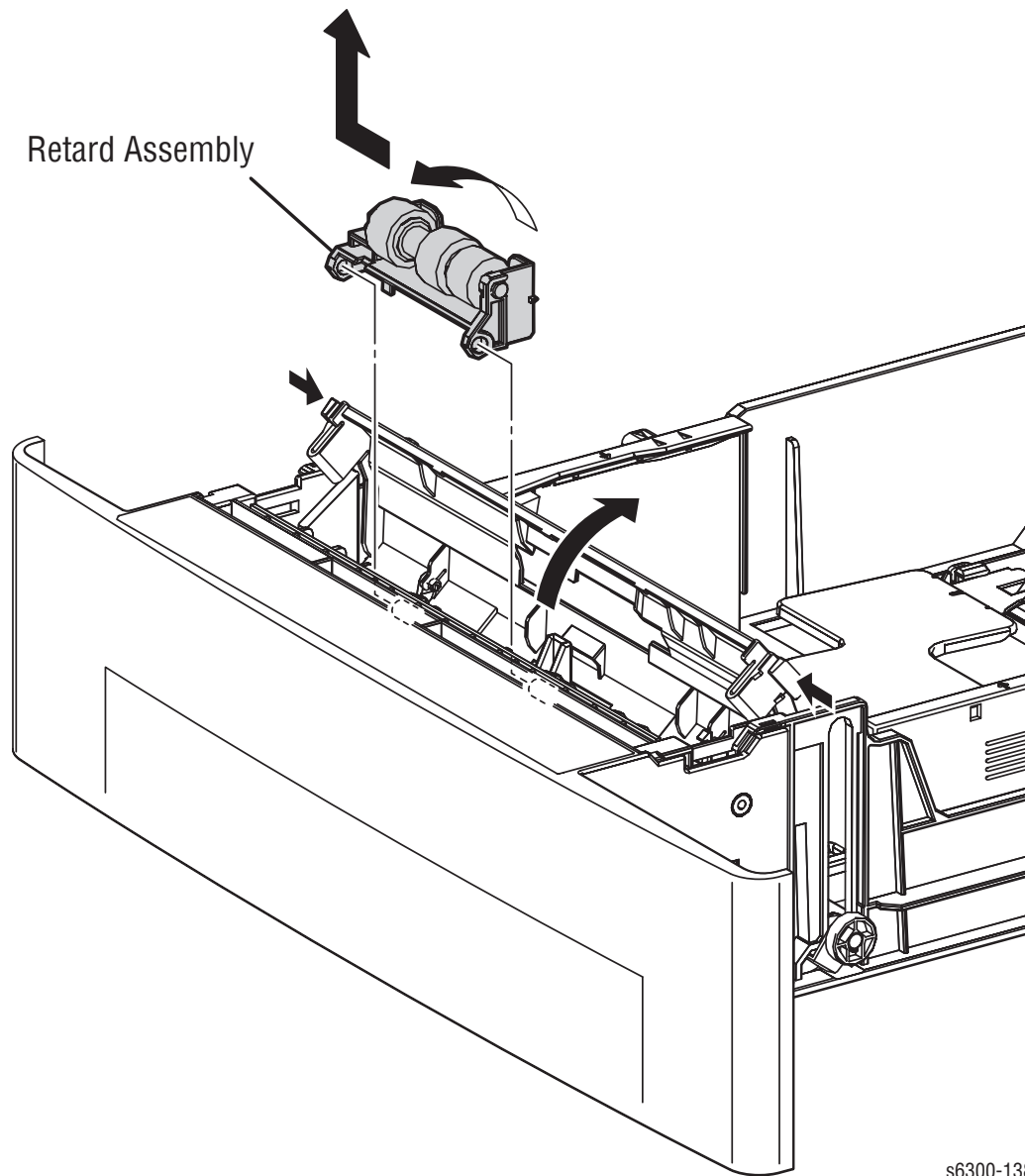

s6300-138

Parts List

In this chapter...

- Serial Number Format
- Using the Parts List
- Print Engine
- Optional 1100-Sheet Feeder
- Optional 550-Sheet Feeder
- Xerox Supplies and Accessories

Section

9

Serial Number Format

Changes to Xerox products are made to accommodate improved components as they become available. As improvements are made, part numbers may change from those appearing in this section. To get the latest part, provide the following information when ordering:

- Component's part number
- Product type or configuration number
- Serial number of the printer

The serial number is coded as follows:

- The text “S/N” followed by the serial number in the barcode.
- The barcode **does not** include a field identifier.
- The nine digit serial number format **PPPRSSSSS** where:

PPP - Is the alphanumeric Product Code

| Product | Configuration | Voltage | Product Code |
|---------|---------------|---------|--------------|
| 6300 | N, DN | 110 V | WHH |
| 6300 | N, DN | 220 V | WHK |
| 6350 | DP, DT, DX | 110 V | WNN |
| 6350 | DP, DT, DX | 220 V | WNP |

R - Is the numeric revision digit. Changes at major product updates or when the serial number is reset to a starting value or (30001, 60001, or 90001).

SSSSS - Is the five digit numeric serial number.

For example:

S/N WHH453072

WHH = Product code for the 6300, configuration N or DN, 110 V Printer

4 = Revision level

53072 = Serial number for 6300 N

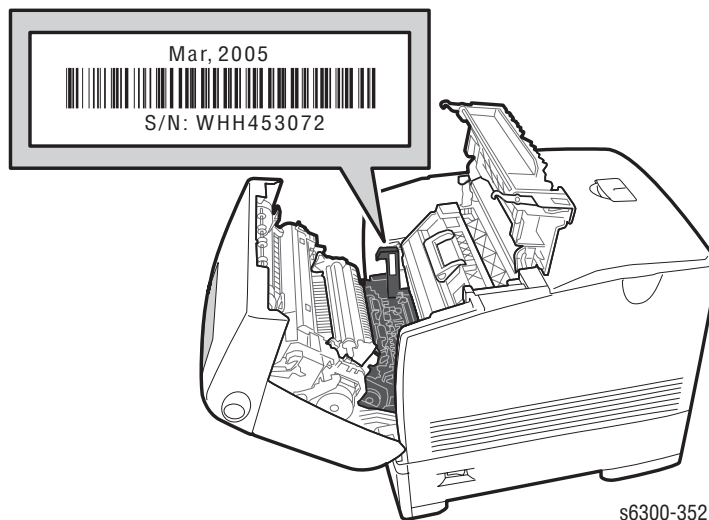

Using the Parts List

Only those parts listed with part numbers are available for order. Parts listed without part numbers are only available as part of a parent assembly or Service Kit.

- 1. No.:** The callout number from the exploded part diagram.
- 2. Part Number:** The material part number used to order specific parts.

Note

An asterisk following the part number identifies parts common to the Phaser 6250 and Phaser 6300/6350. All other parts are unique to the Phaser 6300/6350 printers.

- 3. Name/Description:** Name of the part and number supplied per order.
- 4.** Parts throughout this manual are referenced **PL#.#.#**; For example, PL3.1.10 means the part is item 10 of Parts List 3.1.
- 5.** A black triangle preceding a number followed by a parenthetical statement indicates the item is a parent assembly, made up of the parts listed in parentheses and enclosed by a dashed line.
- 6.** The notation “**(with X~Y)**” following a part name indicates an assembly includes components X through Y. For example, “1 (with 2~4)” means part 1 consists of parts 2, 3, and 4.
- 7.** The notation “**J1<>J2 and P2**” is attached to a wire harness. It indicates that connector Jack 1 is attached to one end of the wire harness and connector J2 is attached to the other end that is plugged into P2.

Legend:

| Identifier | Meaning |
|------------|---------|
| C | C-ring |
| E | E-ring |
| KL | K-clip |
| S | Screw |

Print Engine Parts

Parts List 1.1 Covers

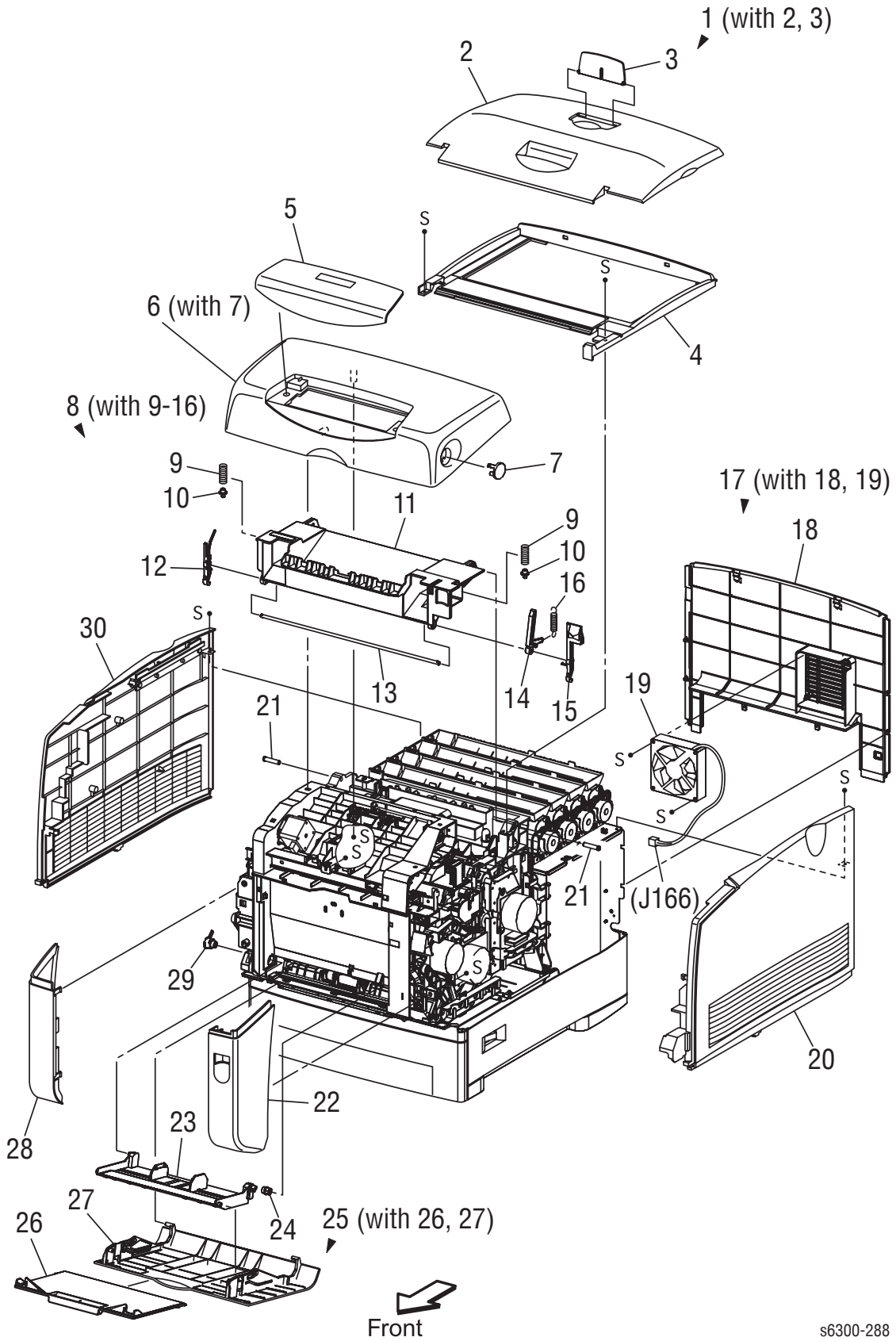

s6300-288

Parts List 1.1 Covers - Service Parts List

| No. | Part Number | Name/Description |
|-----|----------------------------|--|
| 1. | 116-1964-00 | Cover Assy Top (with 2,3) |
| 2. | | Cover, Top |
| 3. | 116-2044-00 | Cover Top Stopper |
| 4. | 116-1965-00 | Cover Top Main |
| 5. | 333-4419-00 333-4424-00 | Control Panel, Phaser 6300 Control Panel, Phaser 6350 |
| 6. | 116-1966-00 | Cover Assy Front (with 7) |
| 7. | | Lever Out |
| 8. | 116-1967-00 | Cover Assy Top (Door C) Imaging Unit (with 9~16) |
| 9. | | Spring L/R |
| 10. | | Plunger |
| 11. | | Cover Top Phd |
| 12. | | Latch Top L |
| 13. | | Shaft Latch |
| 14. | | Latch Top Ir R |
| 15. | | Latch Top R |
| 16. | | Spring Stopper Bottom |
| 17. | | Cover Assy Rear (with 18,19) |
| 18. | 116-1968-00 | Cover Rear |
| 19. | 116-1969-00 | Fan Rear |
| 20. | 116-1970-00 | Cover Side Right |
| 21. | | Stud Top |
| 22. | 116-1971-00 | Cover Front Right |
| 23. | 116-1972-00 | Tray 1 (MPT) Base |
| 24. | Part of Tray Holder Kit | Holder Tray Right |
| 25. | 116-1973-00 | Tray 1 (MPT) (with 26, 27) |
| 26. | | Tray 1 (MPT) Slide |
| 27. | | Cover Tray 1 (MPT) |
| 28. | 116-1974-00 | Cover Front Left |
| 29. | Part of Tray Holder Kit | Holder, Tray Left |
| 30. | 116-1975-00 | Cover Side Left |

Parts List 2.1 Tray 2

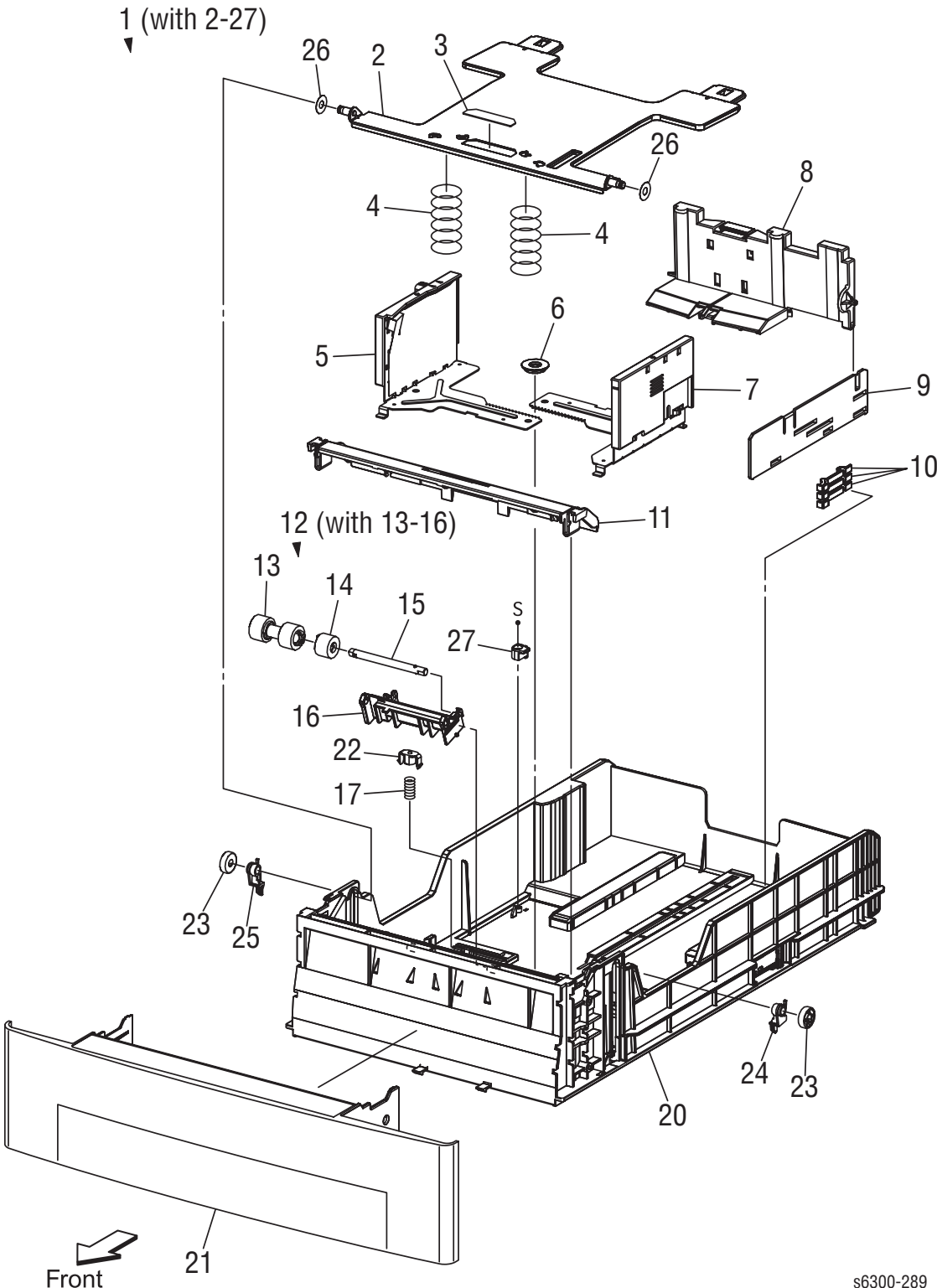

Parts List 2.1 Cassette, Paper - Service Parts List

| ID No. | Part Number | Name/Description |
|--------|-------------------------------|--|
| 1. | 116-1976-00 | Universal Paper Tray (with 2~26) |
| 2. | | Plate Bottom |
| 3. | | Pad Bottom |
| 4. | | Spring N/f |
| 5. | | Guide Side Assy L |
| 6. | | Gear Manual |
| 7. | | Guide Side Assy R |
| 8. | | Guide End Assy |
| 9. | | Actuator Guide End |
| 10. | | Actuator Size |
| 11. | 116-1977-00 | Chute Turn |
| 12. | Part of Paper Feed Roller Kit | Universal Tray Retard Roller Assy (With 13~16) |
| 13. | | Roll Assy |
| 14. | | Clutch Assy Friction |
| 15. | | Shaft Retard |
| 16. | | Holder Retard |
| 17. | | Spring Retard |
| 18. | | |
| 19. | | |
| 20. | | Housing Cst 500 |
| 21. | | Handle Cst |
| 22. | | Holder Spring Retard |
| 23. | | Roll PB |
| 24. | | Stopper Link PB R |
| 25. | | Stopper Link PB L |
| 26. | | Spacer Plate BTM |
| 27. | | Stopper Block |

Parts List 3.1 Feeder (1/3)

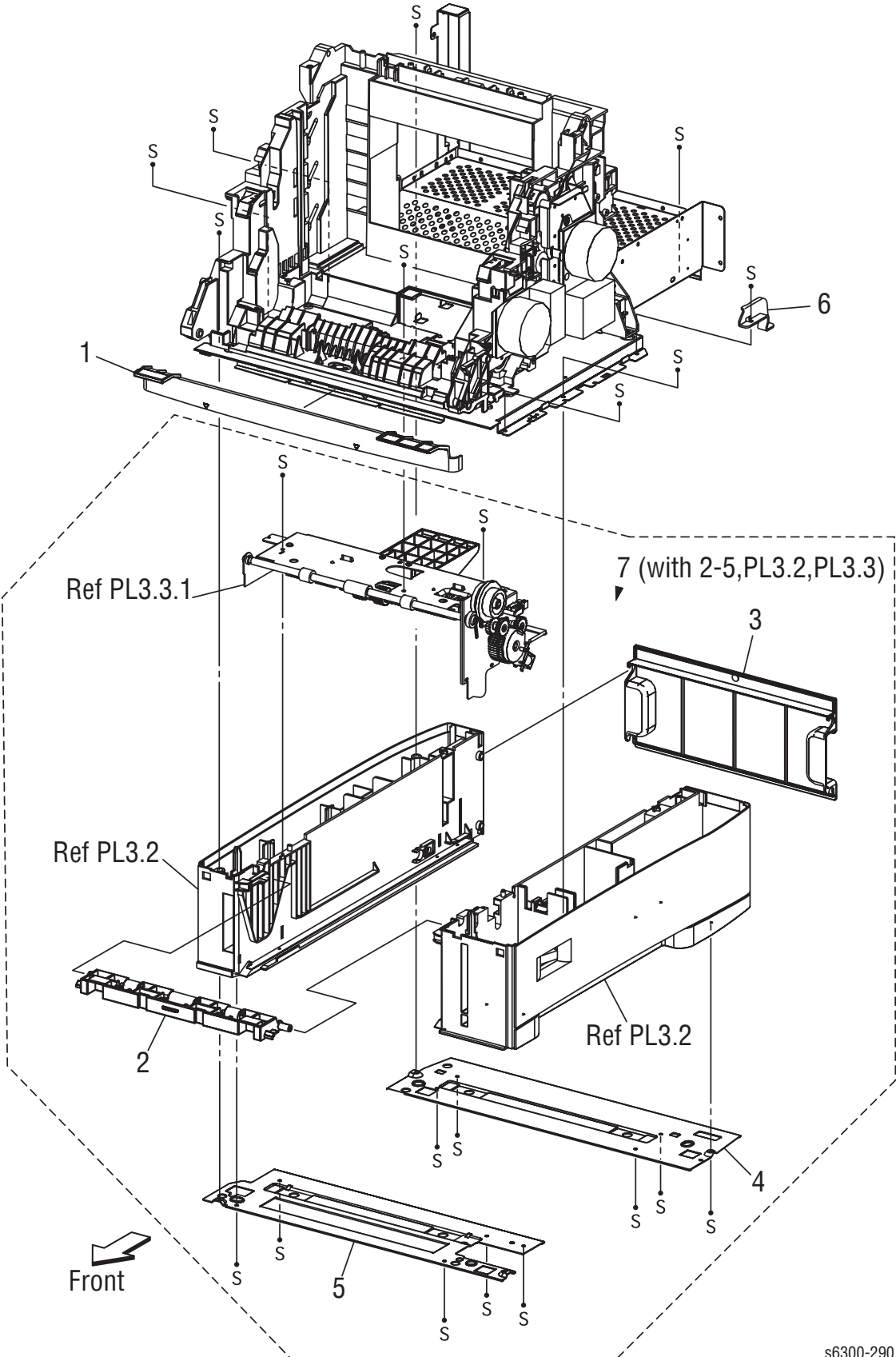

s6300-290

Parts List 3.1 Feeder (1/3) - Service Parts List

| ID No. | Part Number | Name/Description |
|---------------|--------------------|------------------------------------|
| 1. | 116-1978-00 | Frame Feeder Front |
| 2. | 116-1979-00 | Feeder Chute Assy |
| 3. | 116-1980-00 | Cover Paper Tray Rear |
| 4. | | Frame Feeder Bottom Rear |
| 5. | | Frame Feeder Bottom Front |
| 6. | | Support Link SW |
| 7. | 116-1981-00 | Feeder Assy (With 2~5,PL3.2,PL3.3) |

Parts List 3.2 Paper Feeder (2/3)

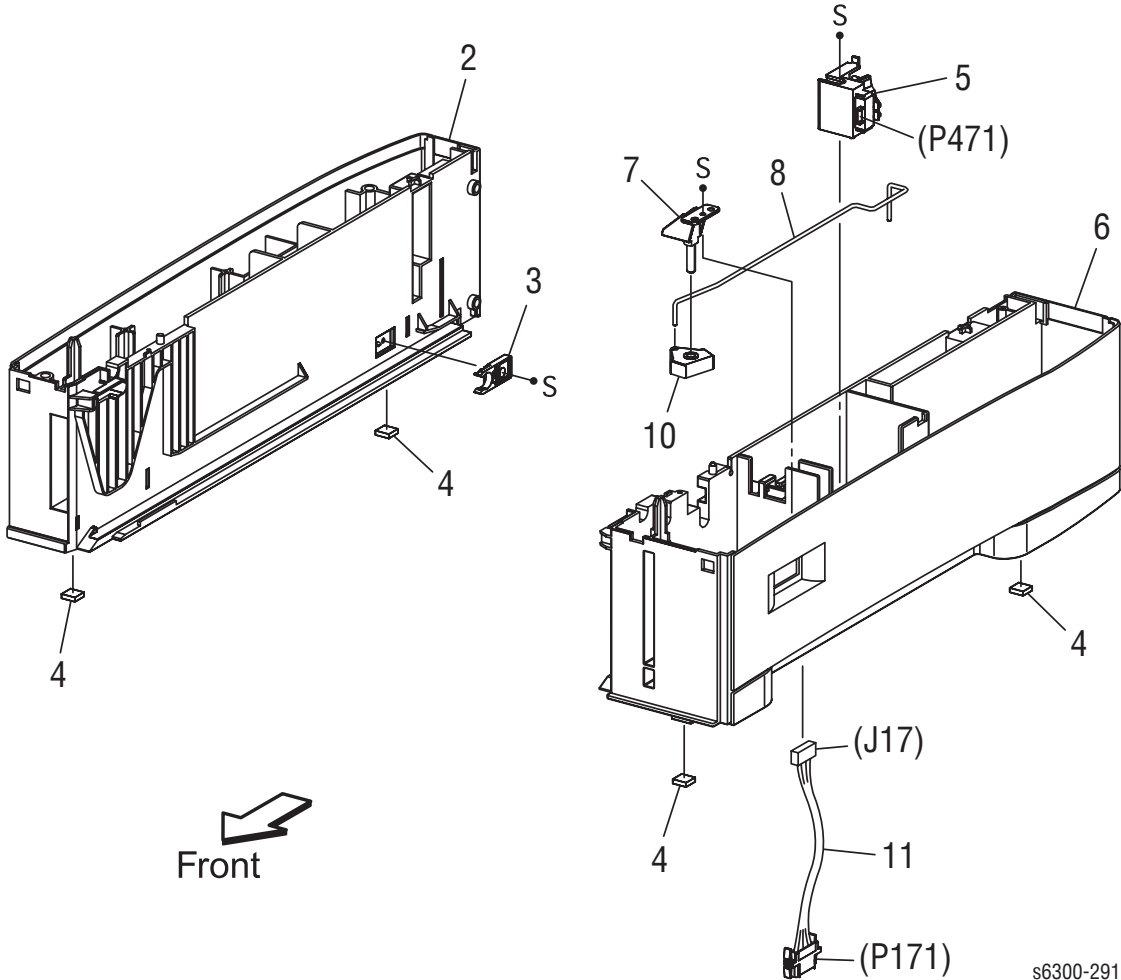

Parts List 3.2 Paper Feeder (2/3) - Service Parts List

| ID No. | Part Number | Name/Description |
|--------|-------------------------------|--------------------------------|
| 1. | | - - |
| 2. | | Feeder L |
| 3. | 116-1351-00 * | Stopper, Paper Tray |
| 4. | 116-1625-00 * | Printer Feet (4 ea. per order) |
| 5. | 116-2045-00 | Paper Size Switch |
| 6. | | Feeder R |
| 7. | | S/W Holder |
| 8. | | Power Switch Link Shaft |
| 9. | | - - |
| 10. | | Power Switch Actuator |
| 11. | Part of Wiring Harness Kit | Harness Assy OPFPLG (J17-P171) |

Parts List 3.3 Paper Feeder (3/3)

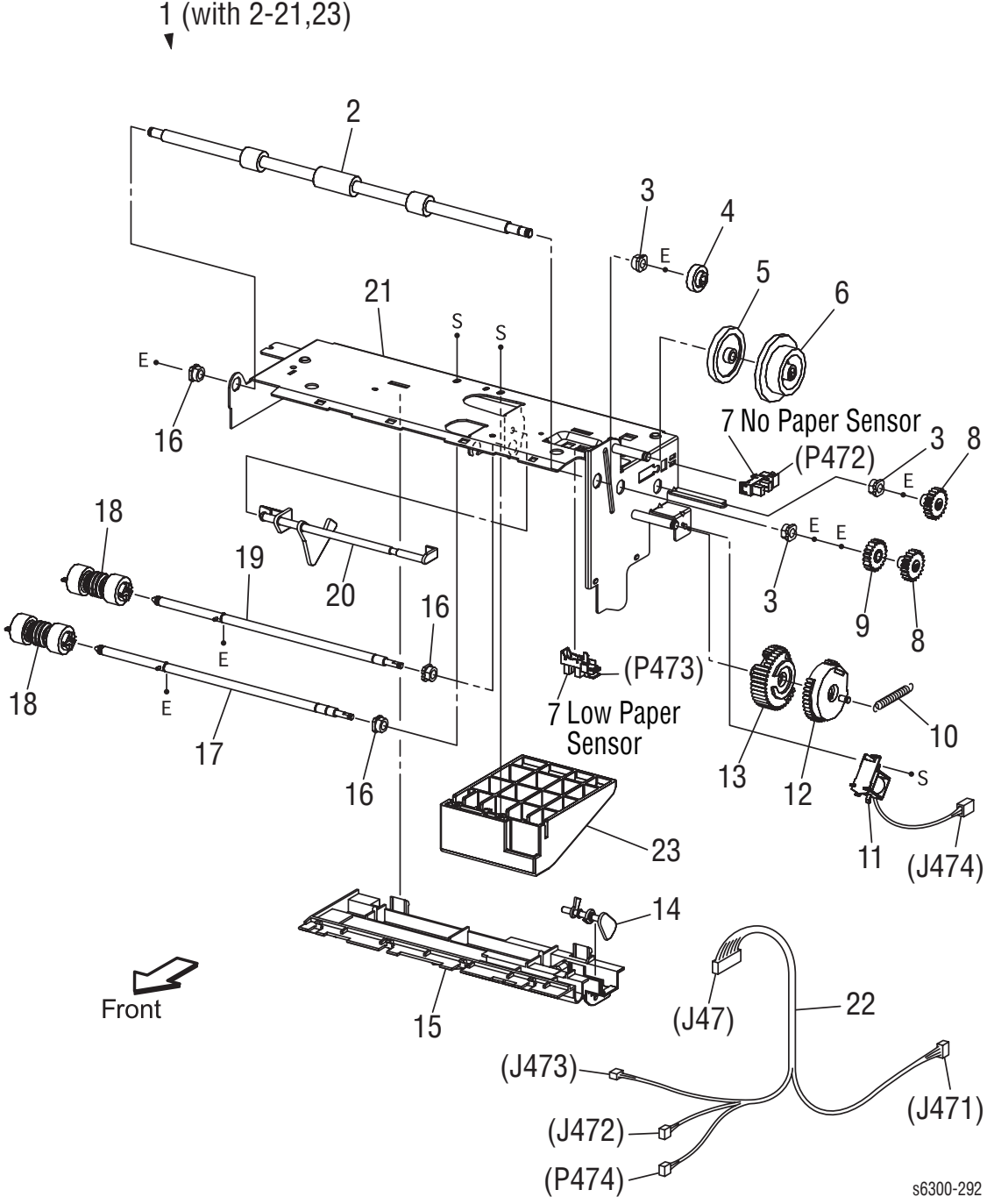

Parts List 3.3 Paper Feeder (3/3) - Service Parts List

| ID No. | Part Number | Name/Description |
|--------|-------------------------------|---|
| 1. | 116-1982-00 | Paper Pick (Pickup Assy) Assembly (with 2~21, 23) |
| 2. | | Roll Assy Turn |
| 3. | | Bearing metal |
| 4. | | Gear Turn |
| 5. | | Gear Idler Turn |
| 6. | | Gear Idler In |
| 7. | 116-1354-00 * | Sensor Photo (Low Paper, No Paper Sensor) |
| 8. | | Gear Feed 2 |
| 9. | | Gear Idler Feed |
| 10. | Part of Spring Kit | Spring Feed H |
| 11. | | Solenoid Feed |
| 12. | | Gear Feed H2 |
| 13. | | Gear Feed H1 |
| 14. | Part of Actuator Kit | Actuator Low Paper |
| 15. | | Chute Upper |
| 16. | | Bearing black |
| 17. | | Shaft Assy Feed |
| 18. | Part of Paper Feed Roller Kit | Roll Assy Feed x 2 |
| 19. | | Shaft Assy Nudger |
| 20. | Part of Actuator Kit | Actuator No Paper |
| 21. | | Frame Assy Drive |
| 22. | Part of Wiring Harness Kit | Harness Assy FDR (J47-J471,J472,J473,P474) |
| 23. | | Guide Paper |

Parts List 4.1 Retard and Registration Assemblies

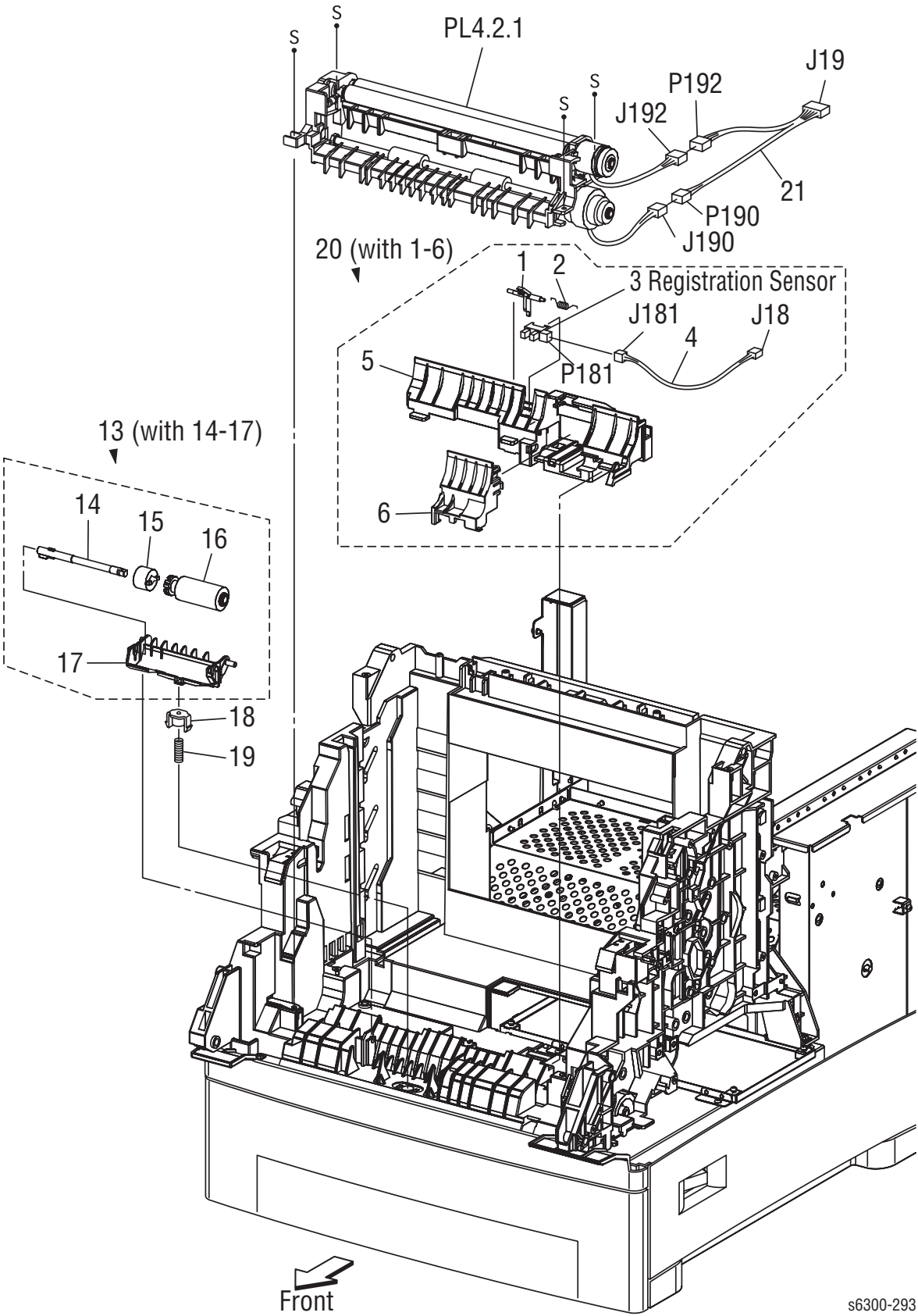

Parts List 4.1 Retard and Registration Assemblies - Service Parts List

| ID No. | Part Number | Name/Description |
|--------|----------------------------|--|
| 1. | Part of Actuator Kit | Actuator Regi |
| 2. | Part of Spring Kit | Spring Sensor Regi |
| 3. | 116-1983-00 | Sensor Photo (Registration Sensor) |
| 4. | | Harness Assy Regi SNS(J18-J181) |
| 5. | | Chute Regi In |
| 6. | | Chute Cover Media |
| 7. | | |
| 8. | | |
| 9. | | |
| 10. | | |
| 11. | | |
| 12. | | |
| 13. | 116-1985-00 | Tray 1 (MPT) Retard Roller Assembly (With 14~17) |
| 14. | | Shaft Retard |
| 15. | | Clutch Assy Friction |
| 16. | | Roll Assy Retard |
| 17. | | Holder Retard |
| 18. | | Holder Spring Retard |
| 19. | | Spring Retard |
| 20. | 116-1986-00 | Registration Chute Assy (with 1~6) |
| 21. | Part of Wiring Harness Kit | Harness Assy FRONTCLH (J19-J191,J192) |

Parts List 4.2 Registration Roller Assembly

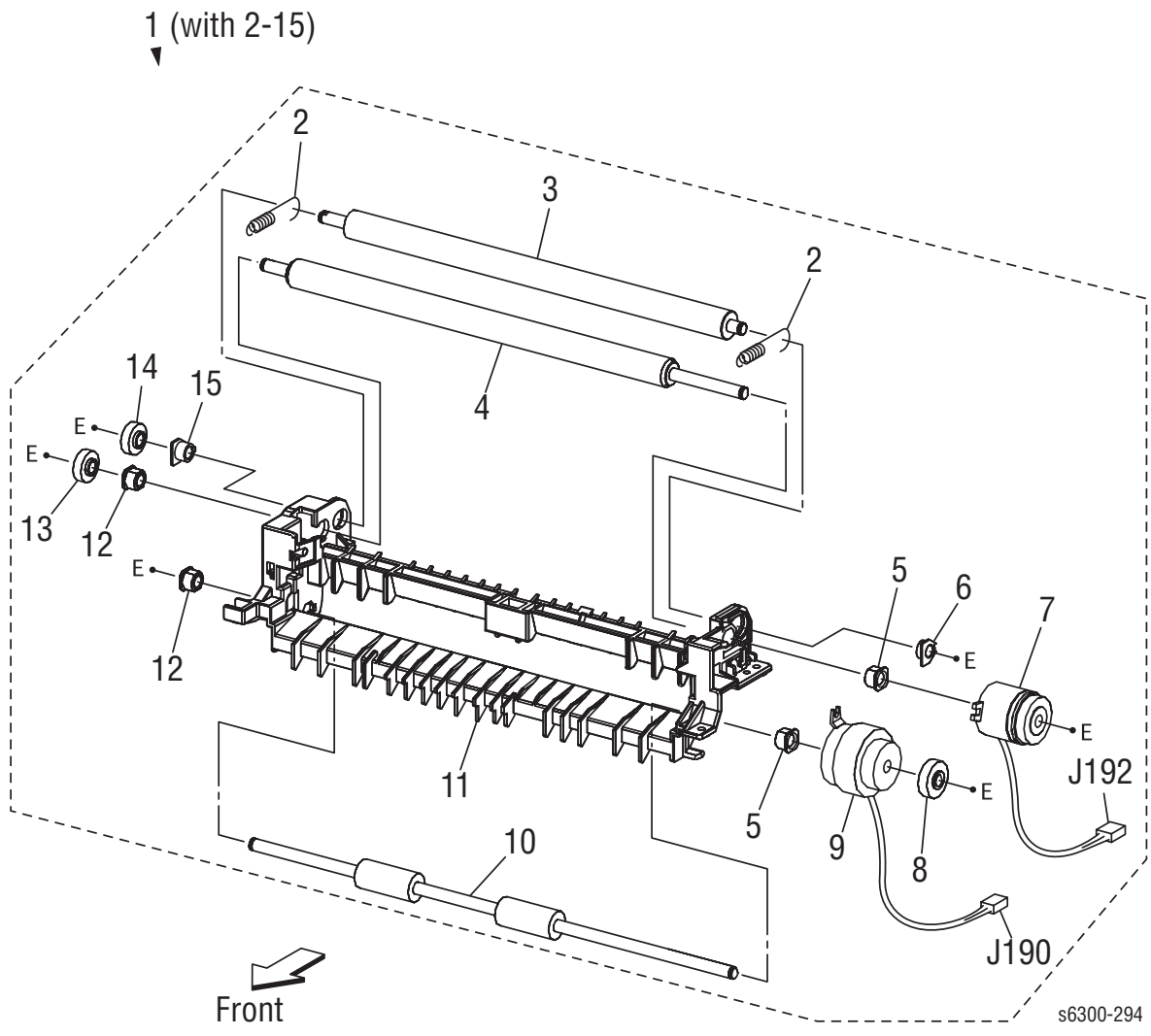

Parts List 4.2 Registration Roller Assembly - Service Parts List

| ID No. | Part Number | Name/Description |
|--------|-------------|--|
| 1. | 116-1987-00 | Registration Roller Assembly (With 2~15) |
| 2. | | Spring Regi |
| 3. | | Roll Regi Metal |
| 4. | | Roll Regi Rubber |
| 5. | | Bearing |
| 6. | | Bearing Metal R |
| 7. | | Clutch Regi |
| 8. | | Gear P1 |
| 9. | | Turn Clutch MPT |
| 10. | | Roll Turn MPT |
| 11. | | Chute Regi |
| 12. | | Bearing Earth |
| 13. | | Gear Regi Rubber |
| 14. | | Gear Regi Metal |
| 15. | | Bearing Metal L |

Parts List 5.1 Chute Assembly In and Out

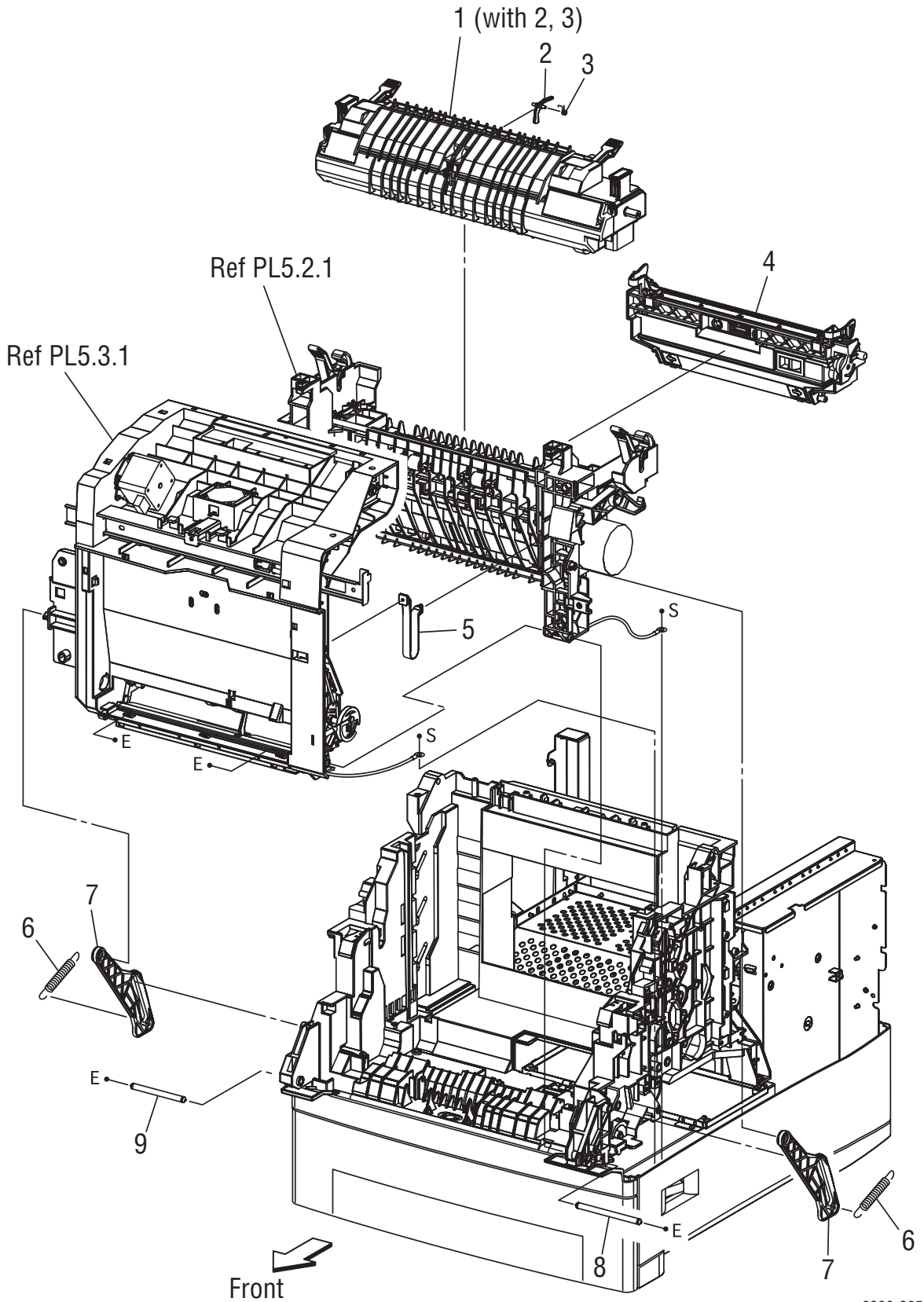

s6300-295

Parts List 5.1 Chute Assembly In and Out - Service Parts List

| ID No. | Part Number | Name/Description |
|--------|------------------------|--|
| 1. | 115R00035 115R00036 | Fuser Assy 110V (with 2,3) Fuser Assy 220V (with 2,3) |
| 2. | Part of Actuator Kit | Actuator Exit |
| 3. | 116-1448-00 * | Spring Actuator |
| 4. | 108R00646 | Transfer Roller (Unit) (BTR) |
| 5. | 116-2042-00 | Stopper Strap |
| 6. | Part of Spring Kit | Spring Link |
| 7. | 116-1988-00 | Link |
| 8. | | Shaft Pivot R |
| 9. | | Shaft Pivot L |

Parts List 5.2 Chute Assembly In

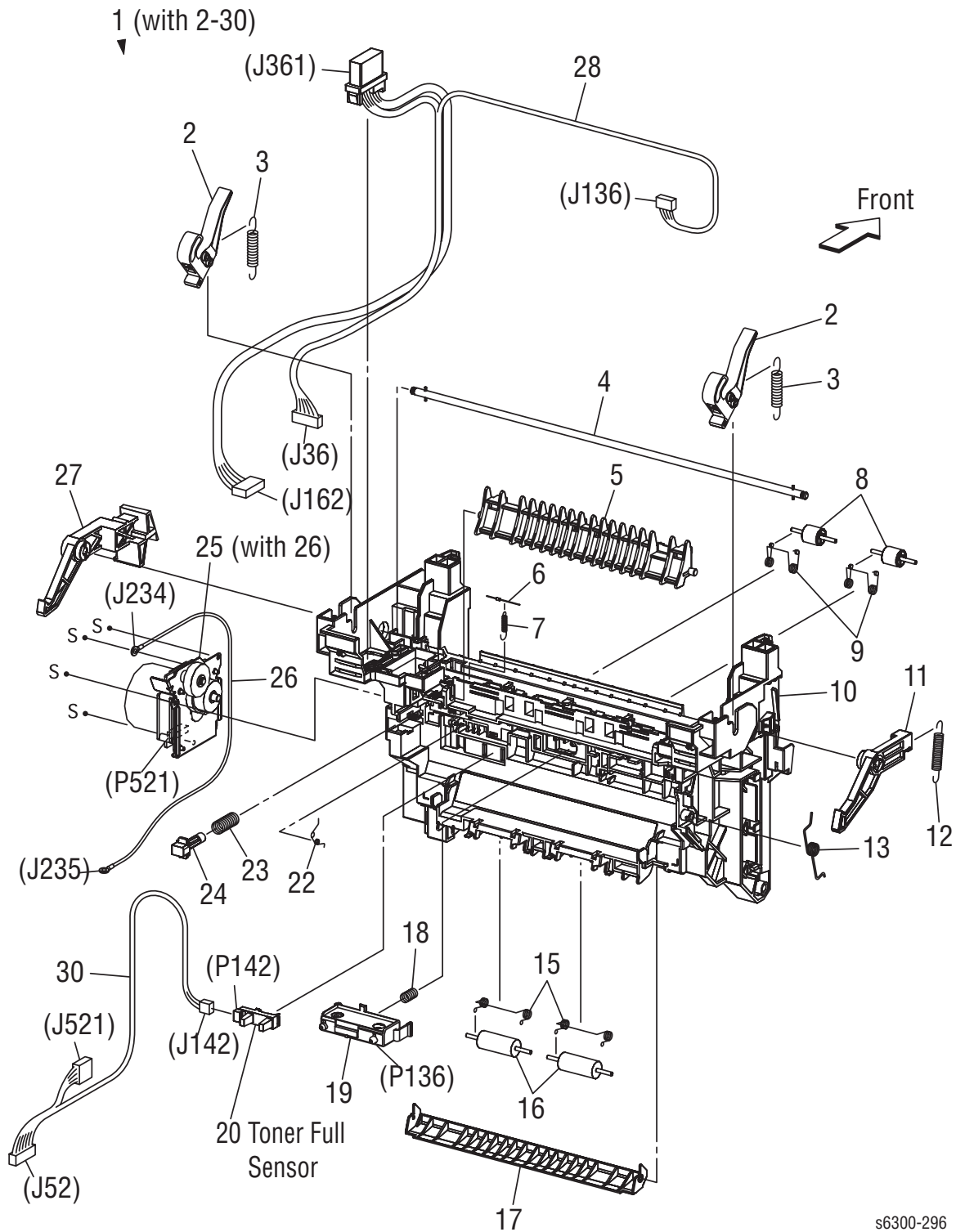

s6300-296

Parts List 5.2 Chute Assembly In - Service Parts List

| ID No | Part Number | Name/Description |
|-------|----------------------------|--|
| 1. | 116-1989-00 | Chute Assy In (with 2~30) |
| 2. | 116-2058-00 | Fuser Lock Lever |
| 3. | Part of Spring Kit | Spring Lever |
| 4. | | Shaft Latch |
| 5. | | Chute FSR In |
| 6. | 116-1990-00 | Diode F |
| 7. | Part of Spring Kit | Spring Diode F |
| 8. | | Roll Pinch Dup |
| 9. | | Spring Pinch Dup |
| 10. | | Chute Dup In |
| 11. | | Latch L |
| 12. | Part of Spring Kit | Spring Latch |
| 13. | | Spring BTR L |
| 14. | | - - |
| 15. | | Spring Pinch T |
| 16. | | Roll Pinch Turn |
| 17. | | Chute Turn In |
| 18. | Part of Spring Kit | Spring ADC |
| 19. | 116-1991-00 | CDT (ADC) Sensor Holder Assy (includes sensor) |
| 20. | 116-1992-00 | Toner Full Sensor |
| 21. | | - - |
| 22. | Part of Spring Kit | Spring Bias DTC |
| 23. | | Spring BTR R |
| 24. | | Stopper BTR R |
| 25. | 116-1993-00 | Fuser Drive Assembly (with 26) |
| 26. | | Wire Assy FSR Earth |
| 27. | | Latch R |
| 28. | Part of Wiring Harness Kit | Harness Assy FSR/ADC (J36-J136,J162,J361) |
| 29. | | - - |
| 30. | Part of Wiring Harness Kit | Harness Assy TNRFULL/FSR (J52-J142,J521) |

Parts List 5.3 Chute Assembly Out - Service Parts List

| ID No. | Part Number | Name/Description |
|--------|----------------------------|--|
| 1. | 116-1994-00 | Chute Assy Out (With 2~35,PL5.4) |
| 2. | | Plate Latch |
| 3. | | Spring Latch |
| 4. | Part of Spring Kit | Spring Bias IDT1-l |
| 5. | | Latch MPT |
| 6. | 116-1995-00 | Resistor Gs1 50m |
| 7. | | Gear MPT |
| 8. | Part of Spring Kit | Spring Feed MPT |
| 9. | 116-1996-00 | Feed Solenoid MPT |
| 10. | | Arm MPT |
| 11. | Part of Spring Kit | Spring N/F MPT |
| 12. | | Follower R |
| 13. | | Follower L |
| 14. | 116-1983-00 | Sensor Photo No Paper (MPT) |
| 15. | Part of Actuator Kit | Actuator No Paper MPT |
| 16. | | Bearing |
| 17. | | Cam MPT |
| 18. | | Shaft MPT |
| 19. | | Roll Core MPT |
| 20. | 116-1997-00 | Feed Roller Assy MPT |
| 21. | | Bearing Earth |
| 22. | | - |
| 23. | | -- |
| 24. | | -- |
| 25. | | -- |
| 26. | | Holder MPT L |
| 27. | 116-2049-00 | Harness Assy Control Panel (OPEPANE2) (J22-J220) |
| 28. | Part of Wiring Harness Kit | Harness Assy FRONT/DUP (J13-P132,J133,J134,J135,P501) |
| 29. | | Wire Assy Dup Earth (J1321-J1322) |
| 30. | 116-1998-00 | Lower Cover |
| 31. | 116-1999-00 | Fuser Fan |
| 32. | 116-2000-00 | Feed Chute |
| 33. | Part of Spring Kit | Spring Earth Out2 |
| 34. | Part of Spring Kit | Spring No Paper MPT |
| 35. | 116-2001-00 | Assy, Plate Bottom |

Parts List 5.4 Chute Assembly Duplex

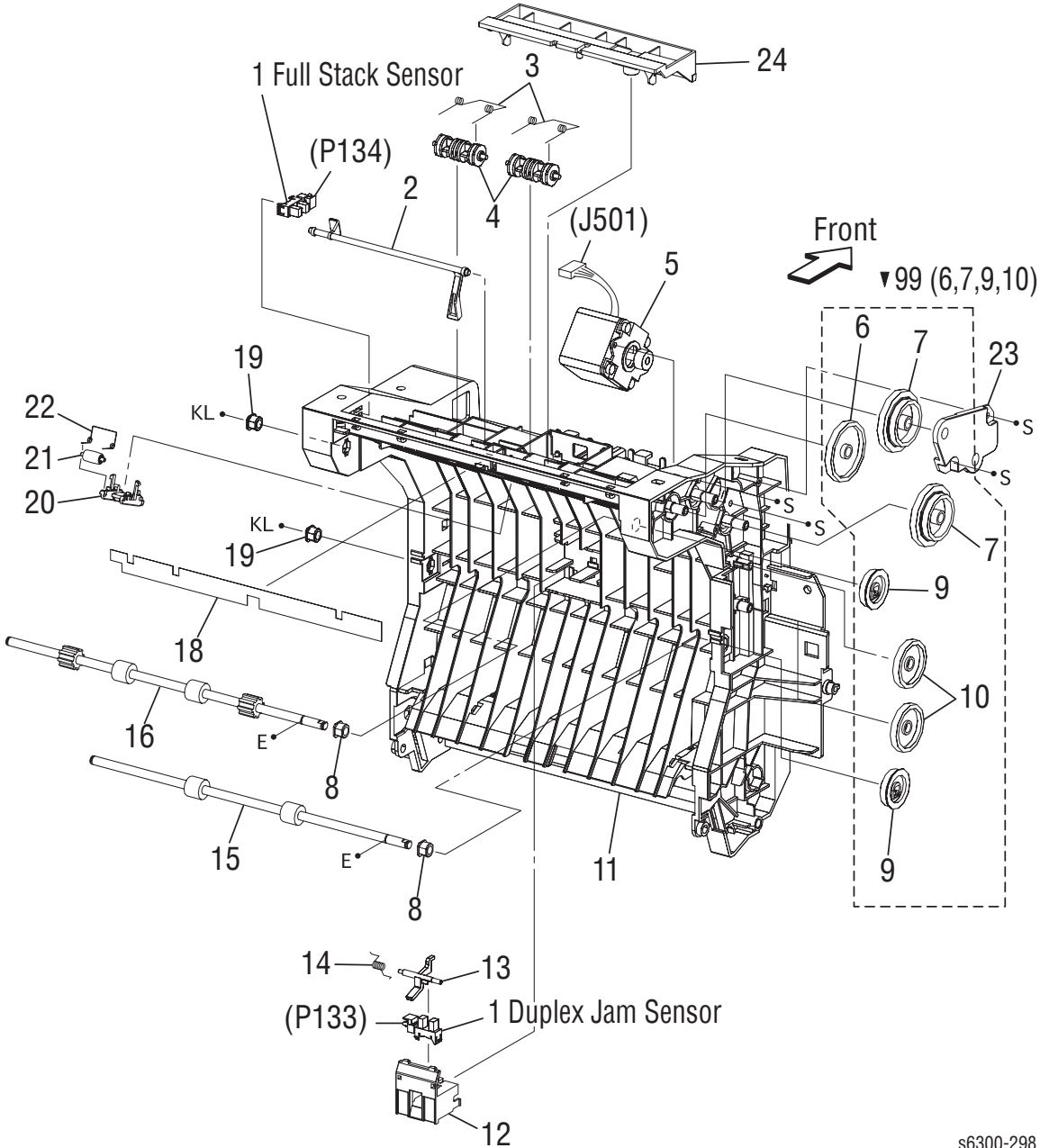

s6300-298

Parts List 5.4 Chute Assembly Duplex - Service Parts List

| ID No. | Part Number | Name/Description |
|--------|----------------------|--|
| 1. | 116-1983-00 | Sensor Photo (Full Stack Sensor) |
| 2. | Part of Actuator Kit | Actuator Full Stack |
| 3. | Part of Spring Kit | Spring Pinch Exit |
| 4. | | Roll Pinch Exit |
| 5. | 116-2002-00 | Duplex Motor Assy |
| 6. | | Gear 52 |
| 7. | | Gear 40/66h |
| 8. | | Bearing |
| 9. | | Gear Exit/dup |
| 10. | | Gear 41 |
| 11. | | Chute Dup Out |
| 12. | | Holder Sensor Dup |
| 13. | 116-1421-00 * | Actuator Duplex Jam |
| 14. | 116-1423-00 * | Actuator Spring Duplex Jam |
| 15. | | Roll Dup |
| 16. | | Roll Exit |
| 17. | | - - |
| 18. | | Eliminator Exit |
| 19. | | Bearing Earth |
| 20. | | Holder Roll |
| 21. | | Roll Corrugate |
| 22. | | Spring Corrugate |
| 23. | | Cover Gear Dupout |
| 24. | | Upper Exit Cover - Not included with PL5.3.1 |
| 99. | 116-2039-00 | Chute Assy Gear Kit (with 6,7,9, 10) |

Parts List 6.1 Xerographics

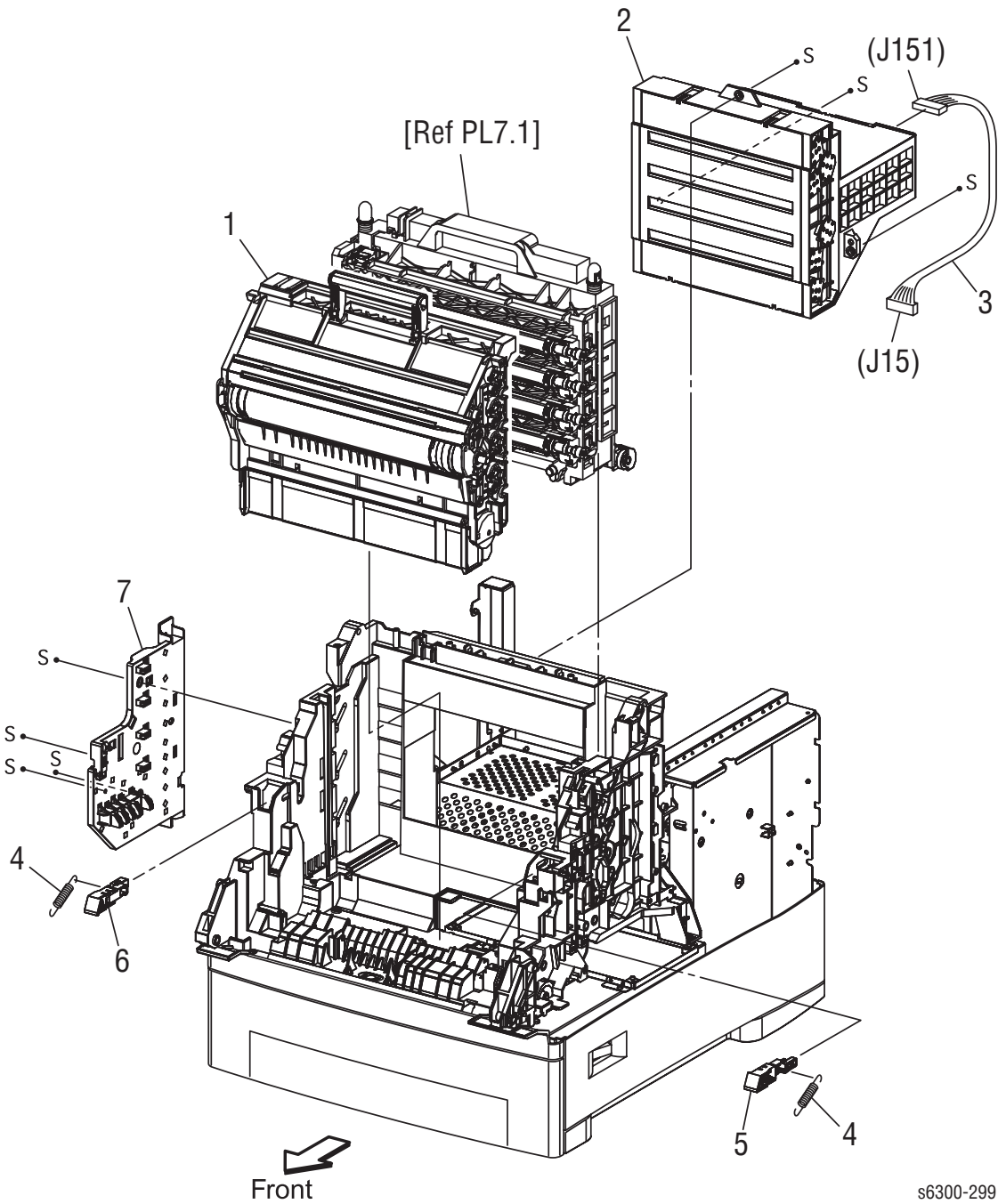

Parts List 6.1 Xerographics - Service Parts List

| ID No. | Part Number | Name/Description |
|---------------|--------------------|-----------------------------|
| 1. | 108R00645 | Imaging Unit (PHD) |
| 2. | 116-2003-00 | Laser Unit (ROS) |
| 3. | 116-2047-00 | Harness Assy Ros (J15-J151) |
| 4. | Part of Spring Kit | Spring Release |
| 5. | 116-2004-00 | Lever Stopper Right |
| 6. | 116-2005-00 | Lever Stopper Left |
| 7. | 116-2006-00 | Housing Assy Bias |

Parts List 7.1 Development (1/2)

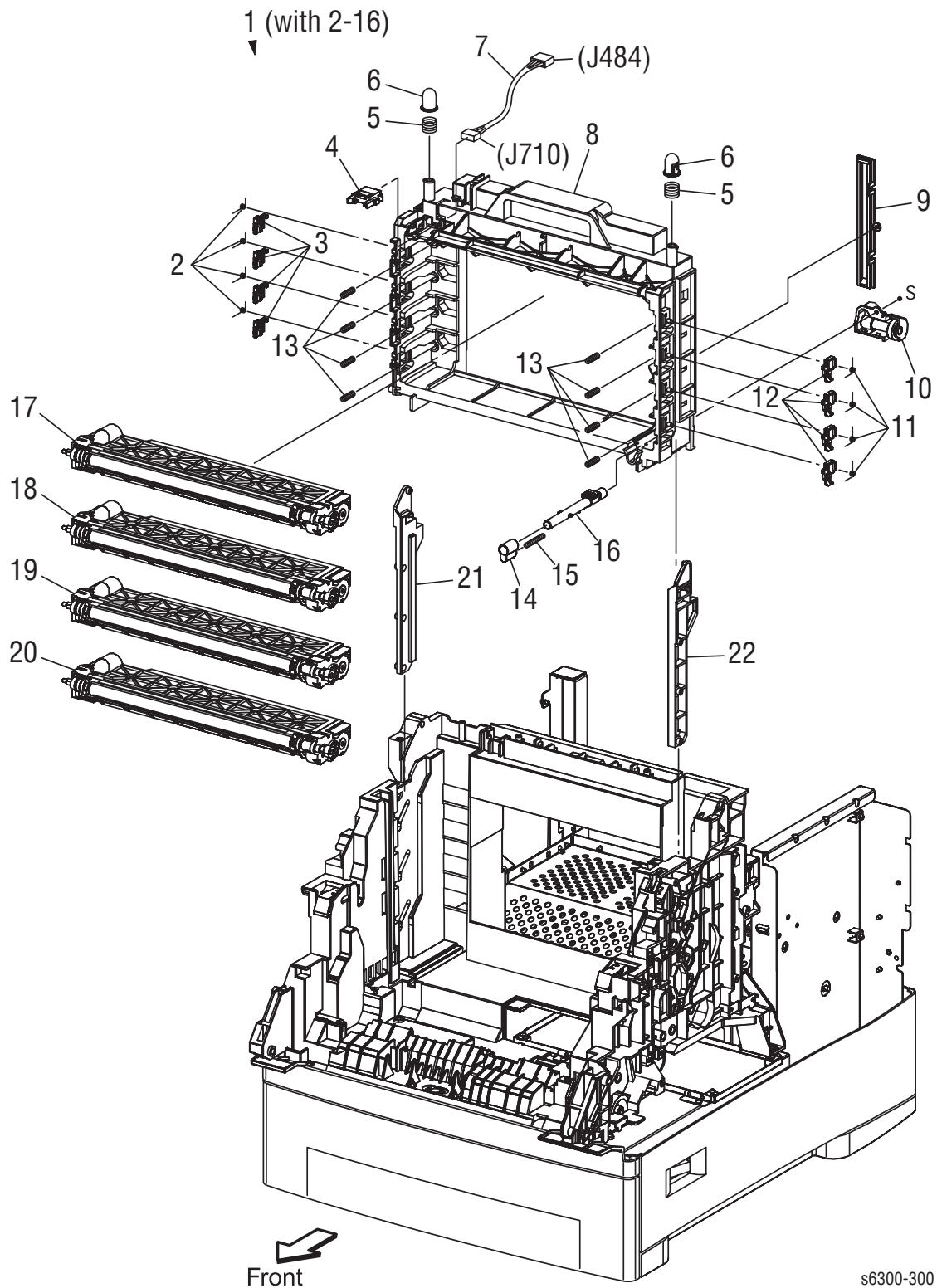

Parts List 7.1 Development (1/2) - Service Parts List

| ID No. | Part Number | Name/Description |
|---------------|--------------------|----------------------------------|
| 1. | 116-2007-00 | Developer Frame Assy (with 2~16) |
| 2. | | Spring L |
| 3. | | Stopper Deve L |
| 4. | 116-2048-00 | CRUM Connector |
| 5. | | Spring Plunger |
| 6. | | Plunger Frame |
| 7. | 116-2051-00 | Harnass Assy PHD2 (J484-J710) |
| 8. | | Frame Deve |
| 9. | | Cover Assy Frame |
| 10. | | Gear Assy Duct |
| 11. | | Spring R |
| 12. | | Stopper Deve R |
| 13. | 116-2052-00 | Spring Tracking (Qty. 1) |
| 14. | | Shutter Duct |
| 15. | | Spring Shutter Duct |
| 16. | | Nozzle Assy Duct |
| 17. | 116-2008-00 | Developer Assy (Y) |
| 18. | 116-2009-00 | Developer Assy (M) |
| 19. | 116-2010-00 | Developer Assy (C) |
| 20. | 116-2011-00 | Developer Assy (K) |
| 21. | 116-2012-00 | Guide Frame Deve Left |
| 22. | 116-2013-00 | Guide Frame Deve Right |

Parts List 7.2 Development (2/2)

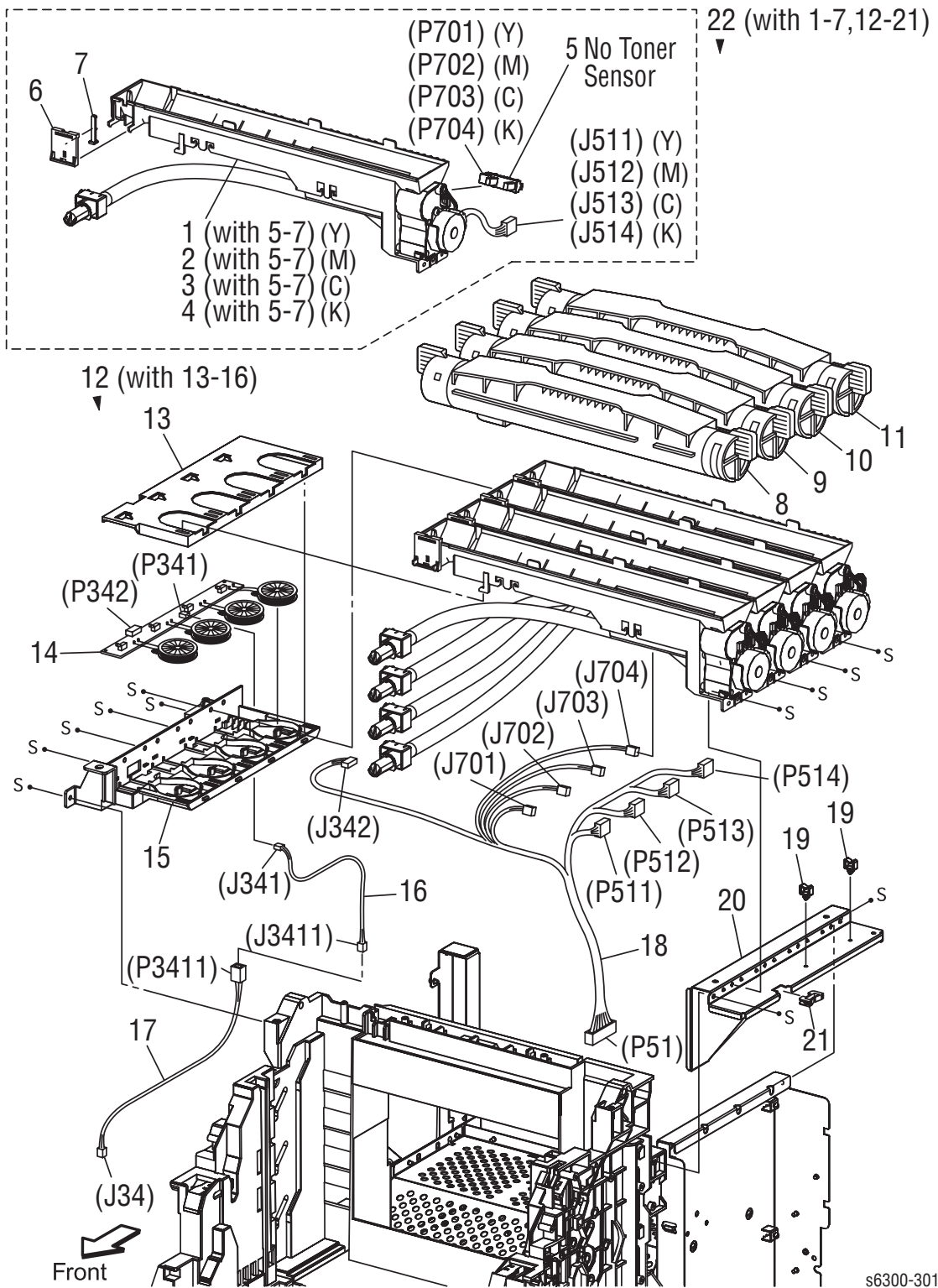

Parts List 7.2 Development (2/2) - Service Parts List

| ID No. | Part Number | Name/Description |
|--------|----------------------------|--|
| 1. | 116-2014-00 | Holder, Toner Cartridge Assy, Yellow (with 5~7) |
| 2. | 116-2015-00 | Holder, Toner Cartridge Assy, Magenta (with 5~7) |
| 3. | 116-2016-00 | Holder, Toner Cartridge Assy, Cyan (with 5~7) |
| 4. | 116-2017-00 | Holder, Toner Cartridge Assy, Black (with 5~7) |
| 5. | 116-2046-00 | Sensor No Toner |
| 6. | 116-1604-00 * | Switch Bracket, Toner CTG-IN |
| 7. | 116-1605-00 * | Actuator Toner CTG-IN |
| 8. | See (page 9-60) | Toner Cartridge (Y) |
| 9. | See (page 9-60) | Toner Cartridge (M) |
| 10. | See (page 9-60) | Toner Cartridge (C) |
| 11. | See (page 9-60) | Toner Cartridge (K) |
| 12. | 116-2018-00 | Box Assy CRUM Reader (With 13~16) |
| 13. | | Cover Holder CRUM |
| 14. | | Coil Assy CRUM Reader |
| 15. | | Hsg Base CRUM |
| 16. | | Harness Assy RFID2 (J341-J3411) |
| 17. | 116-2053-00 | Harness Assy RFID(J34-P3411) |
| 18. | Part of Wiring Harness Kit | Harness Assy TNR (J51-J342,P511,P512,P513,P514,J701,J702,J703,J704) |
| 19. | | Clamp Mini-sdl |
| 20. | | Bracket Holder Dsp |
| 21. | | Saddle Bush |
| 22. | | Dispenser Toner Hi Assy (With 1-7,12-21) |

Parts List 8.1 Drive - Service Parts List

| ID No. | Part Number | Name/Description |
|---------------|--------------------|--------------------------|
| 1 | 116-2019-00 | Developer Drive Assembly |
| 2 | 116-2020-00 | Main Drive Assembly |
| 3 | | Clamp |

Parts List 9.1 Electrical - Service Parts List

| ID No. | Part Number | Name/Description |
|--------|---------------|---|
| 1. | | - - |
| 2. | | Plate Assy Rear |
| 3. | 650-4365-00 | Image Processor Board (with 2, 28~31) |
| 4. | | Box Assy LVPS |
| 5. | | - |
| 6a. | 116-2037-00 | Low Voltage Power Supply (LVPS), 110V (with 4, 7) |
| 6b. | 116-2038-00 | Low Voltage Power Supply (LVPS), 220V (with 4, 7) |
| 7. | | Harness Assy AC Inlet |
| 8. | | - - |
| 9. | | Clamp |
| 10. | 161-0312-00 | Power Cord - Unique to Phaser 6300/ 6350 |
| 11. | 116-2021-00 | Interlock Switch Assy |
| 12. | 116-2022-00 | EEPROM Circuit Board |
| 13. | 116-1489-00 * | Clamp Guide Harness |
| 14. | | Guide Harness R |
| 15. | | Guide Harness F |
| 16. | 116-2036-00 | Engine Control (MCU) Circuit Board (with 17) |
| 17. | | Bracket Assy MCU |
| 18. | | Cover Elec |
| 19. | | Bracket Temp |
| 20. | 116-2023-00 | Temperature/Humidity Sensor |
| 21. | 116-2041-00 | High Voltage Power Supply (HVPS) Board |
| 22. | 163-1521-00 | Configuration Card, N configuration - Phaser 6300 Only |
| 23. | 163-1525-00 | Configuration Card, DN configuration - Phaser 6300 Only |
| 24. | 163-1522-00 | Configuration Card, DP configuration - Phaser 6350 Only |
| 25. | 650-4364-00 | Internal 20 GB Hard Drive |
| 26. | 856-0003-00 | 256 MB, 16M x 64, PC133; Memory DIMM |
| 27. | 856-0004-00 | 512 MB, 32M x 64, PC133; Memory DIMM |
| 28. | 116-1459-00 | IP Board NVRAM |
| 29. | | PWB Bracket Left |
| 30. | | PWB Bracket Right |
| 31. | | Block PWB |

Parts List 10.1 Harness Assemblies

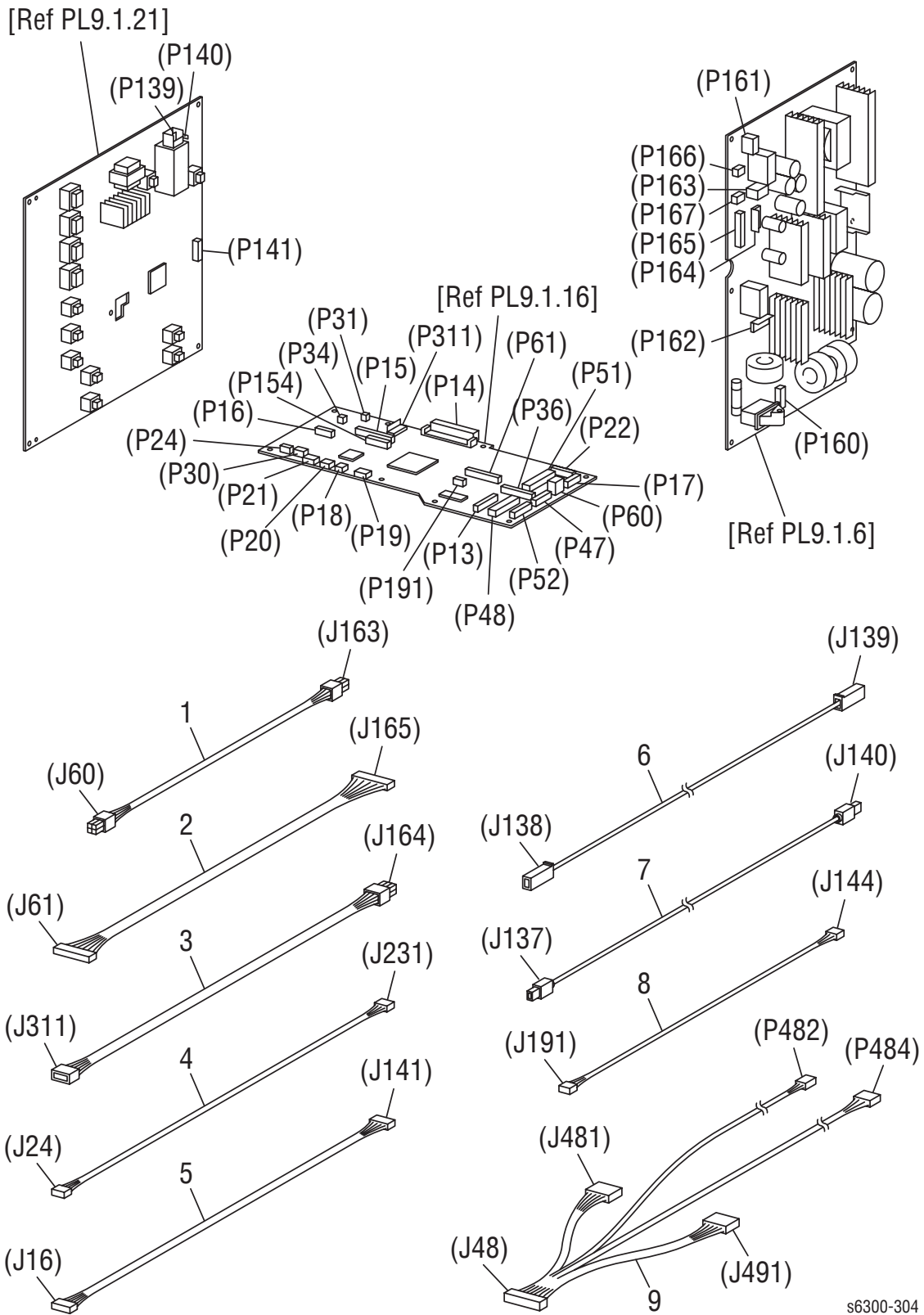

s6300-304

Parts List 10.1 - Harness Assemblies - Service Parts List

| ID No. | Part Number | Name/Description |
|---------------|----------------------------|--|
| 1. | Part of Wiring Harness Kit | Harness Assy 24V (J60-J163) |
| 2. | Part of Wiring Harness Kit | Harness Assy LV (J61-J165) |
| 3. | Part of Wiring Harness Kit | Harness Assy LV RPG (J164-J311) |
| 4. | Part of Wiring Harness Kit | Harness Assy TMP (J24-J231) |
| 5. | Part of Wiring Harness Kit | Harness Assy HVPS (J16-J141) |
| 6. | Part of Wiring Harness Kit | Wire Assy BTR (J138-J139) |
| 7. | Part of Wiring Harness Kit | Wire Assy Regi (J137-J140) |
| 8. | Part of Wiring Harness Kit | Harness Assy EEPROM (J191-J1911) |
| 9. | Part of Wiring Harness Kit | Harness Assy FAN/PHD/MOT (J48-J481,J482,J484,J491) |

Optional 550-Sheet Feeder

Parts List 11.1 550-Sheet Feeder (1/2)

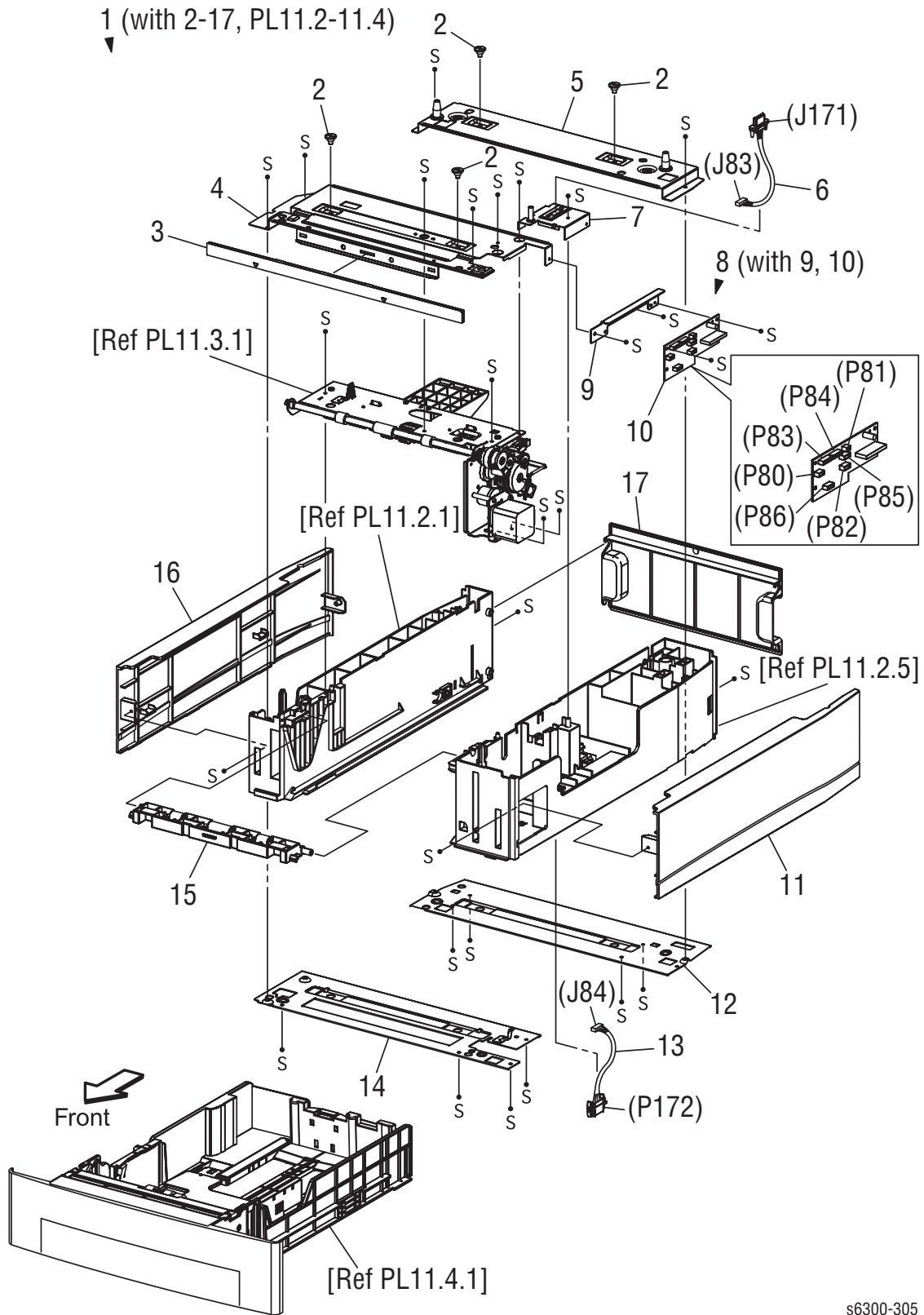

s6300-305

Parts List 11.1 550-Sheet Feeder (1/2) - Service Parts List

| ID No. | Part Number | Name/Description |
|--------|-------------------------------|--|
| 1. | 119-6561-00 | 550-Sheet Feeder (with 2-17,PL11.2~11.4) |
| 2. | | Screw Joint |
| 3. | | Cover Front |
| 4. | | Frame Assy Top Front |
| 5. | | Frame Assy Top Rear |
| 6. | Part of Wiring Harness Kit | Harness Assy OPFREC (J83-J171) |
| 7. | | Plate Connector |
| 8. | | PWB Assy (with 9,10) |
| 9. | | Plate PWBA |
| 10. | | PWBA OPTFDR |
| 11. | | Cover Right |
| 12. | | Plate Bottom Rear |
| 13. | | Harness Assy OPFPLG2 (J84-P172) |
| 14. | | Plate Bottom Front |
| 15. | 116-1979-00 | Feeder Chute |
| 16. | | Cover Left |
| 17. | 116-1980-00 | Cover, Paper Tray Rear |

Parts List 11.2 550-Sheet Feeder (2/2)

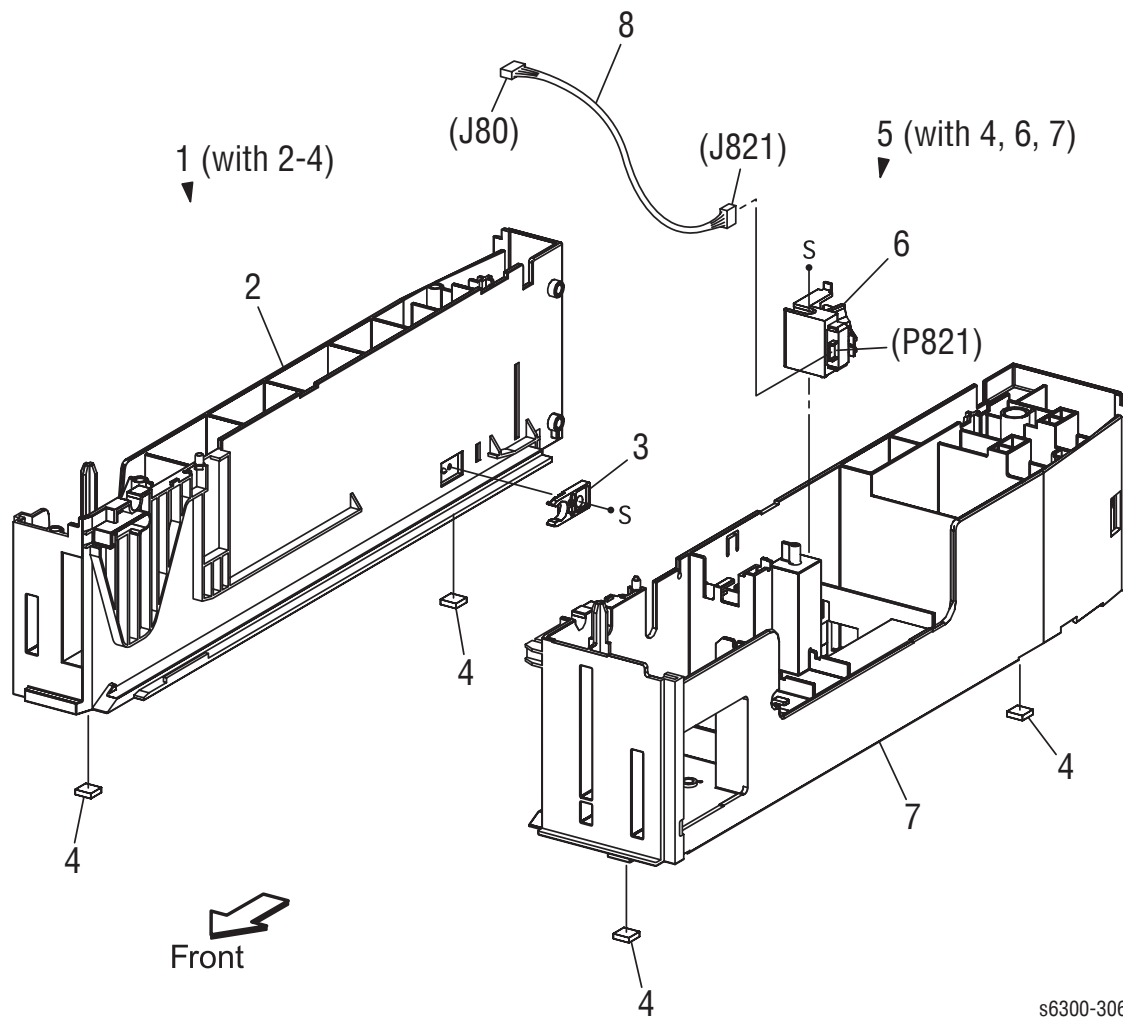

s6300-306

Parts List 11.2 550-Sheet Feeder (2/2) - Service Parts List

| ID No. | Part Number | Name/Description |
|---------------|--------------------|--------------------------------|
| 1. | | Feeder Assy Left (with 2~4) |
| 2. | | Housing Left |
| 3. | 116-1351-00 * | Stopper, Paper Tray |
| 4. | 116-1625-00 * | Printer Feet (4 ea. per order) |
| 5. | | Feeder Assy Right (with 4,6,7) |
| 6. | 116-2045-00 | Paper Size Switch Assy |
| 7. | | Housing Right |
| 8. | | Harness Assy SIZE (J80-J821) |

Parts List 11.3 Tray 3 Paper Pick Assembly

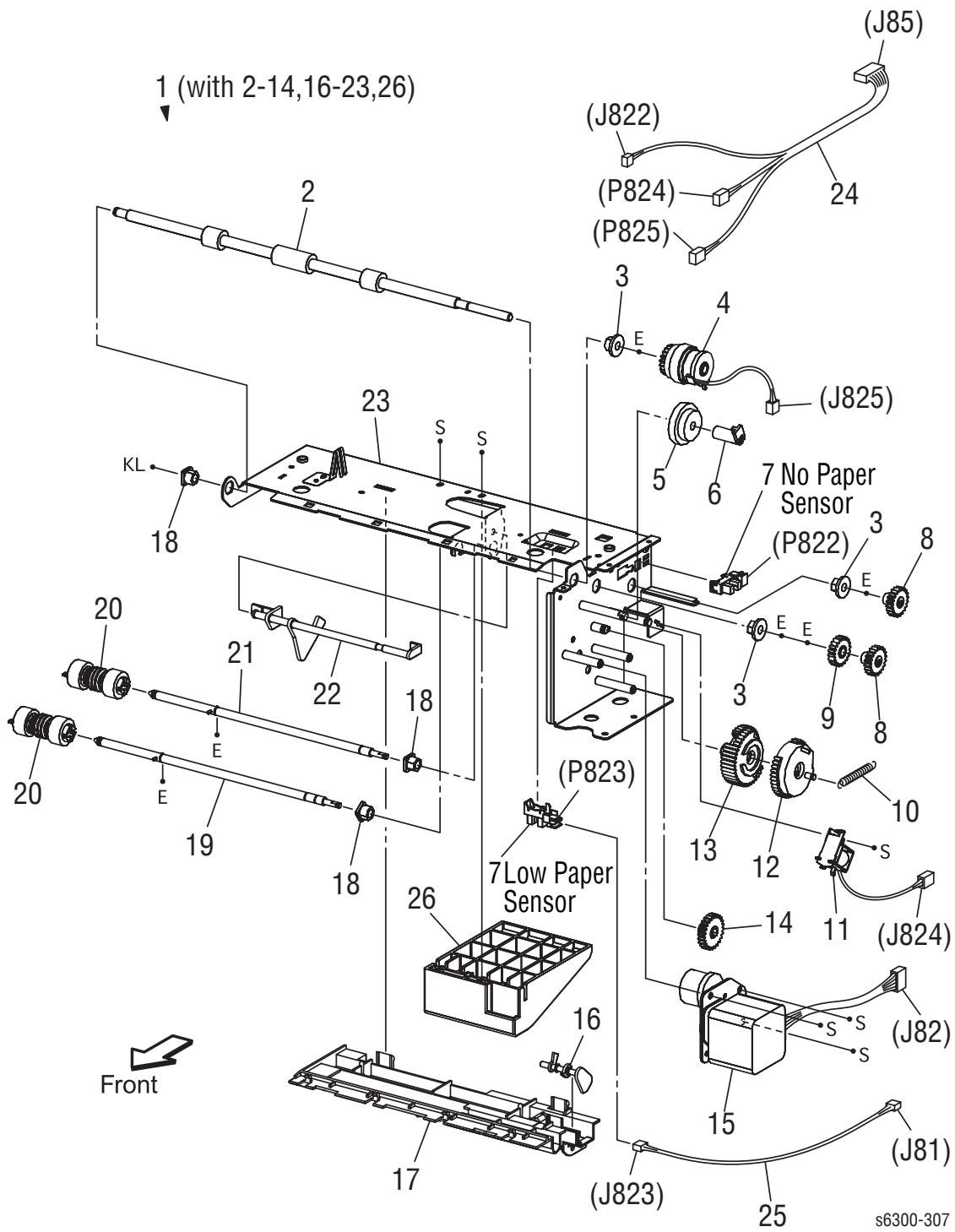

Parts List 11.3 Tray 3 Paper Pick Assembly - Service Parts List

| ID No. | Part Number | Name/Description |
|--------|-------------------------------|---|
| 1. | | Paper Pick (Pickup Assy) Assembly (with 2~14,16~23, 26) |
| 2. | | Roll Assy Turn |
| 3. | | Bearing (F6xL8)/Metal |
| 4. | | Clutch Assy |
| 5. | | Gear Idle 21/29 |
| 6. | | Stopper Clutch |
| 7. | 116-1354-00 * | Sensor Photo (No Paper, Low Paper Sensor) |
| 8. | | Gear Feed2 |
| 9. | | Gear Idler Feed |
| 10. | Part of Spring Kit | Spring Feed H |
| 11. | | Solenoid Feed |
| 12. | | Gear Feed H2 |
| 13. | | Gear Feed H1 |
| 14. | | Gear 24 |
| 15. | | Drive Assy |
| 16. | Part of Actuator Kit | Actuator Low Paper |
| 17. | | Chute Upper |
| 18. | | Bearing (F6xL8)/Black |
| 19. | | Shaft Assy Feed |
| 20. | Part of Paper Feed Roller Kit | Roll Assy Nudger x 2 |
| 21. | | Shaft Assy Nudger |
| 22. | Part of Actuator Kit | Actuator No Paper |
| 23. | | Frame Assy Pickup |
| 24. | | Harness Assy OPFDR (J85-J822,P824,P825) |
| 25. | | Harness Assy LOWP (J81-J823) |
| 26. | | Guide Paper |

Parts List 11.4 Universal Paper Tray

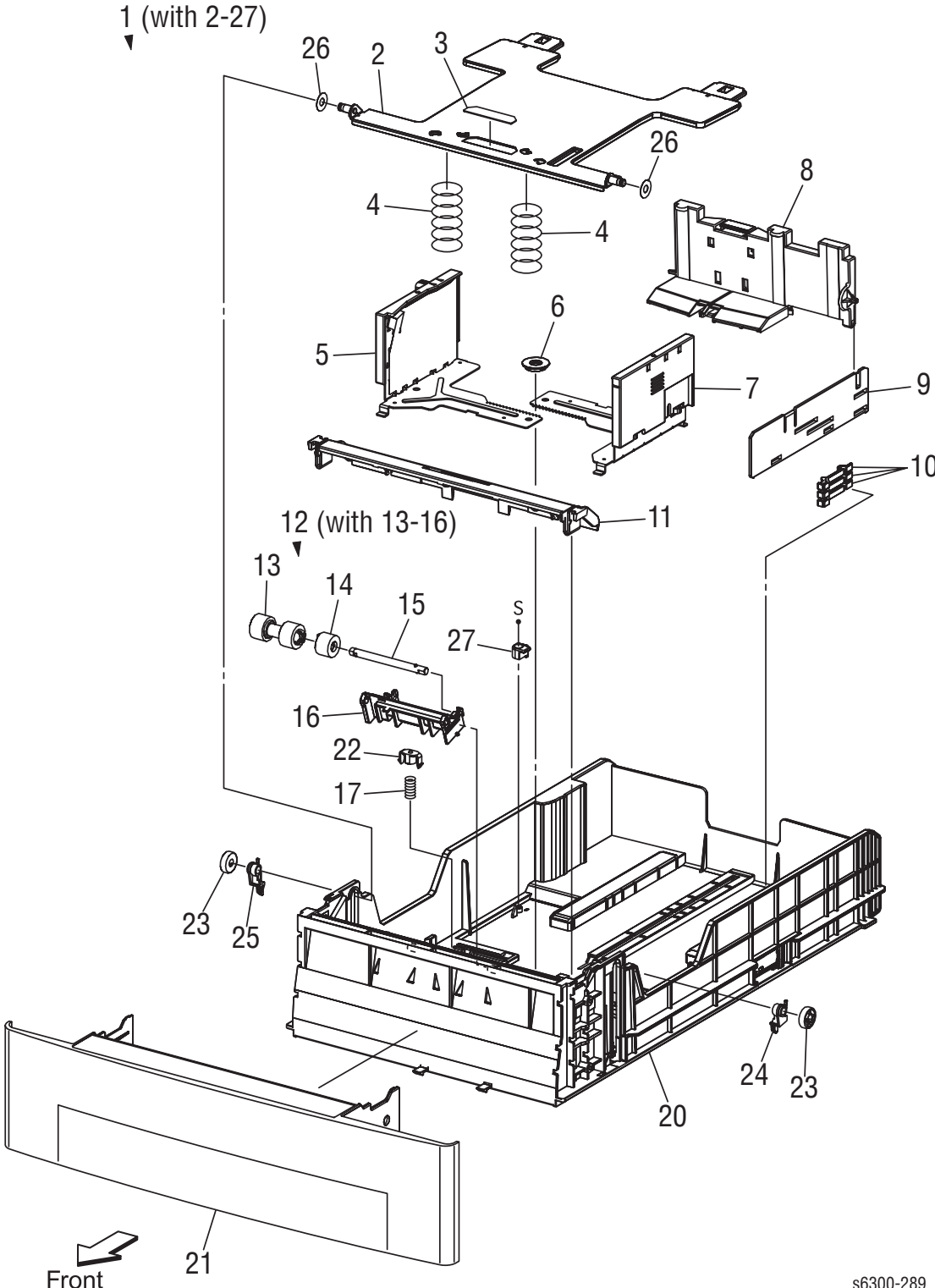

s6300-289

Parts List 11.4 Universal Paper Tray - Service Parts List

| ID No. | Part Number | Name/Description |
|--------|-------------------------------|----------------------------------|
| 1. | 116-1976-00 | Universal Paper Tray (with 2~26) |
| 2. | | Plate Assy Btm |
| 3. | | Pad Bottom |
| 4. | | Spring N/F |
| 5. | | Guide Assy Side L |
| 6. | | Gear Manual |
| 7. | | Guide Assy Side R |
| 8. | | Guide Assy End |
| 9. | | Actuator Guide End |
| 10. | | Actuator Size |
| 11. | 116-1977-00 | Chute Turn |
| 12. | Part of Paper Feed Roller Kit | Retard Assy (with 13~16) |
| 13. | | Roll Assy Retard |
| 14. | | Clutch Assy Friction |
| 15. | | Shaft Assy Retard |
| 16. | | Holder Retard |
| 17. | | Spring Retard |
| 18. | | -- |
| 19. | | -- |
| 20. | | Housing Cst 500 |
| 21. | | Handle Cst |
| 22. | | Holder Spring Retard |
| 23. | | Roll PB |
| 24. | | Stopper Link PB R |
| 25. | | Stopper Link PB L |
| 26. | | Spacer Plate Btm |
| 27. | | Stopper Block |

Optional 1100-Sheet Feeder

Parts List 12.1 1100-Sheet Feeder Covers

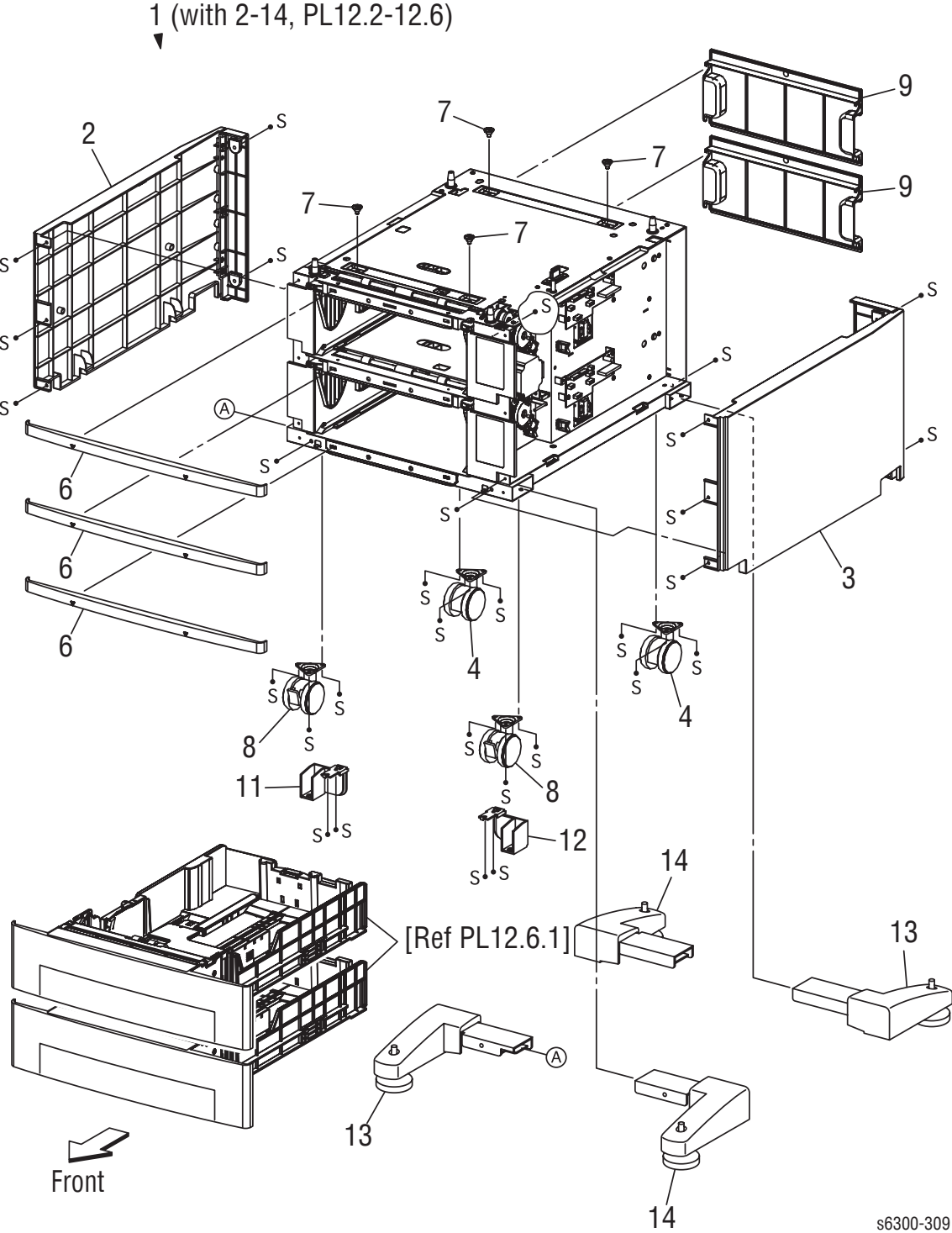

Parts List 12.1 1100-Sheet Feeder Covers - Service Parts List

| ID No. | Part Number | Name/Description |
|---------------|--------------------|---|
| 1. | 119-6562-00 | 1100-Sheet Feeder (with 2~12,PL12.2~PL12.6) |
| 2. | 116-2024-00 | Cover Left |
| 3. | 116-2025-00 | Cover Right |
| 4. | 116-2054-00 | Caster (Non-locking) |
| 5. | | - - |
| 6. | | Cover Front |
| 7. | | Screw Joint |
| 8. | 116-2055-00 | Caster (Locking) |
| 9. | 116-1980-00 | Cover, Paper Tray Rear |
| 10. | | |
| 11. | | Caster Stopper 1 |
| 12. | | Caster Stopper 2 |
| 13. | 116-2056-00 | Foot Assy A |
| 14. | 116-2057-00 | Foot Assy B |

Parts List 12.2 Feeders

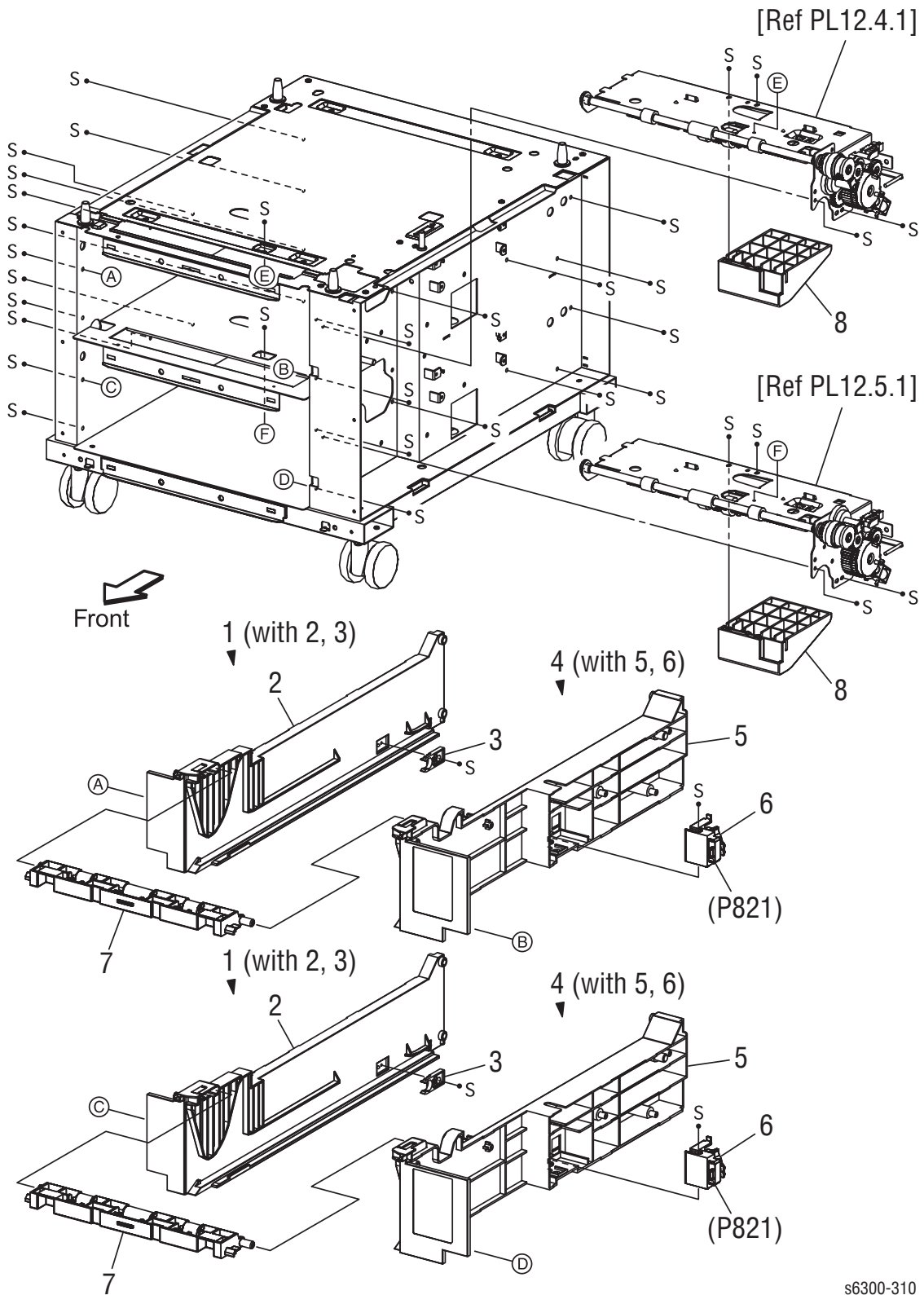

s6300-310

Parts List 12.2 Feeders - Service Parts List

| ID No. | Part Number | Name/Description |
|--------|---------------|------------------------------|
| 1. | | Feeder Assy Left (with 2,3) |
| 2. | | Guide Cst L |
| 3. | 116-1351-00 * | Stopper Paper Tray |
| 4. | | Feeder Assy Right (with 5,6) |
| 5. | | Guide Cst R |
| 6. | 116-1625-00 | Paper Size Switch Assy |
| 7. | 116-1979-00 | Feeder Chute |
| 8. | | Guide Paper |

Parts List 12.3 Harness

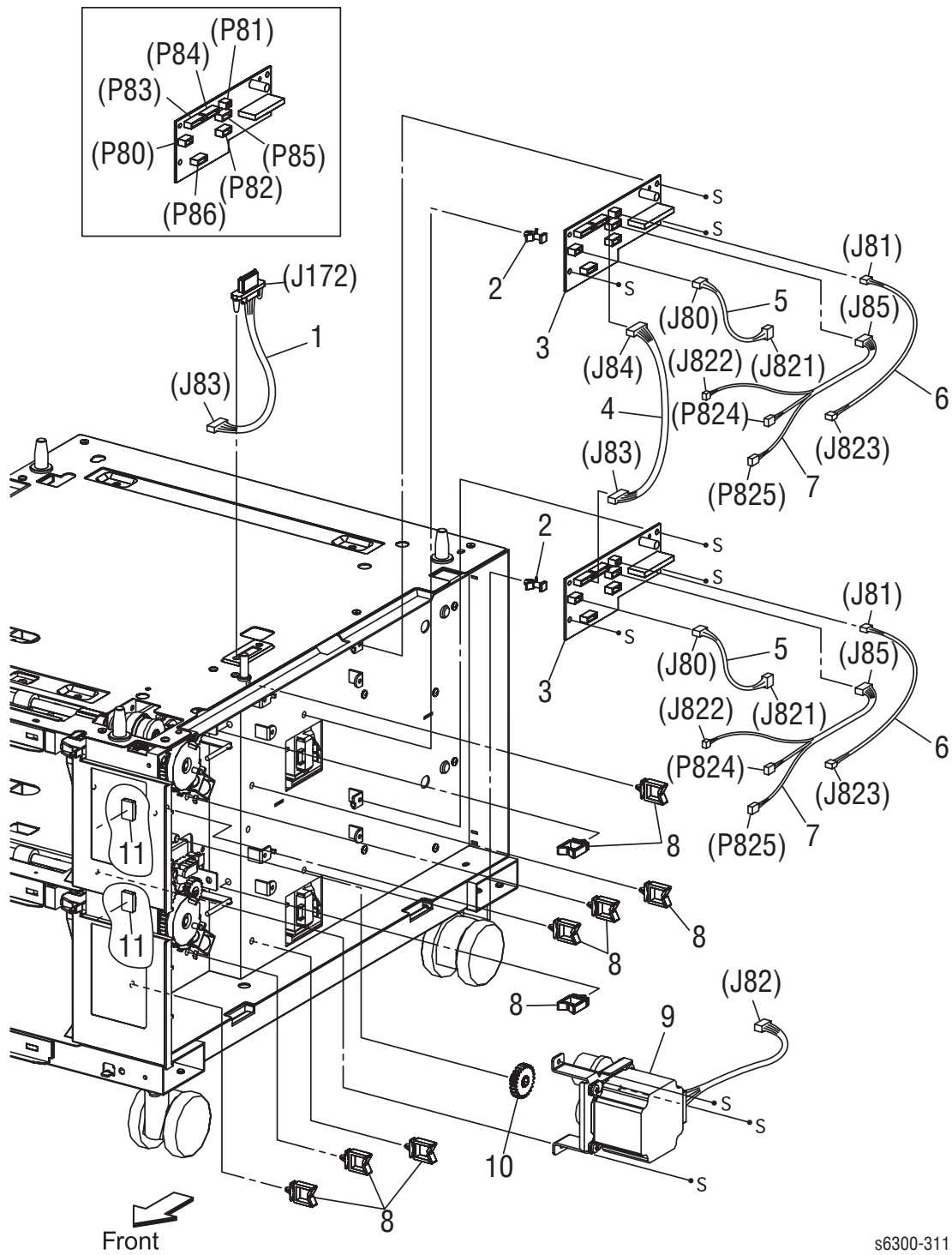

s6300-311

Parts List 12.3 Harness - Service Parts List

| ID No. | Part Number | Name/Description |
|--------|----------------------------|--|
| 1. | Part of Wiring Harness Kit | Harness Assy OPFREC2 (J83-J172) |
| 2. | | Spacer |
| 3. | 116-2027-00 | Circuit Board HCF (OPTFDR 2 PWBA) |
| 4. | | Harness Assy OPF23 (J83-J84) |
| 5. | | Harness Assy SIZE2 (J80-J821) |
| 6. | | Harness Assy LOWP2 (J81-J823) |
| 7. | | Harness Assy OPFDR2 (J85-J822, P824, P825) |
| 8. | | Clamp Saddle |
| 9. | 116-2028-00 | Drive Assy HCF |
| 10. | | Gear 24 |
| 11. | | Clamp |

Parts List 12.4 Paper Pick Assembly HCF T1

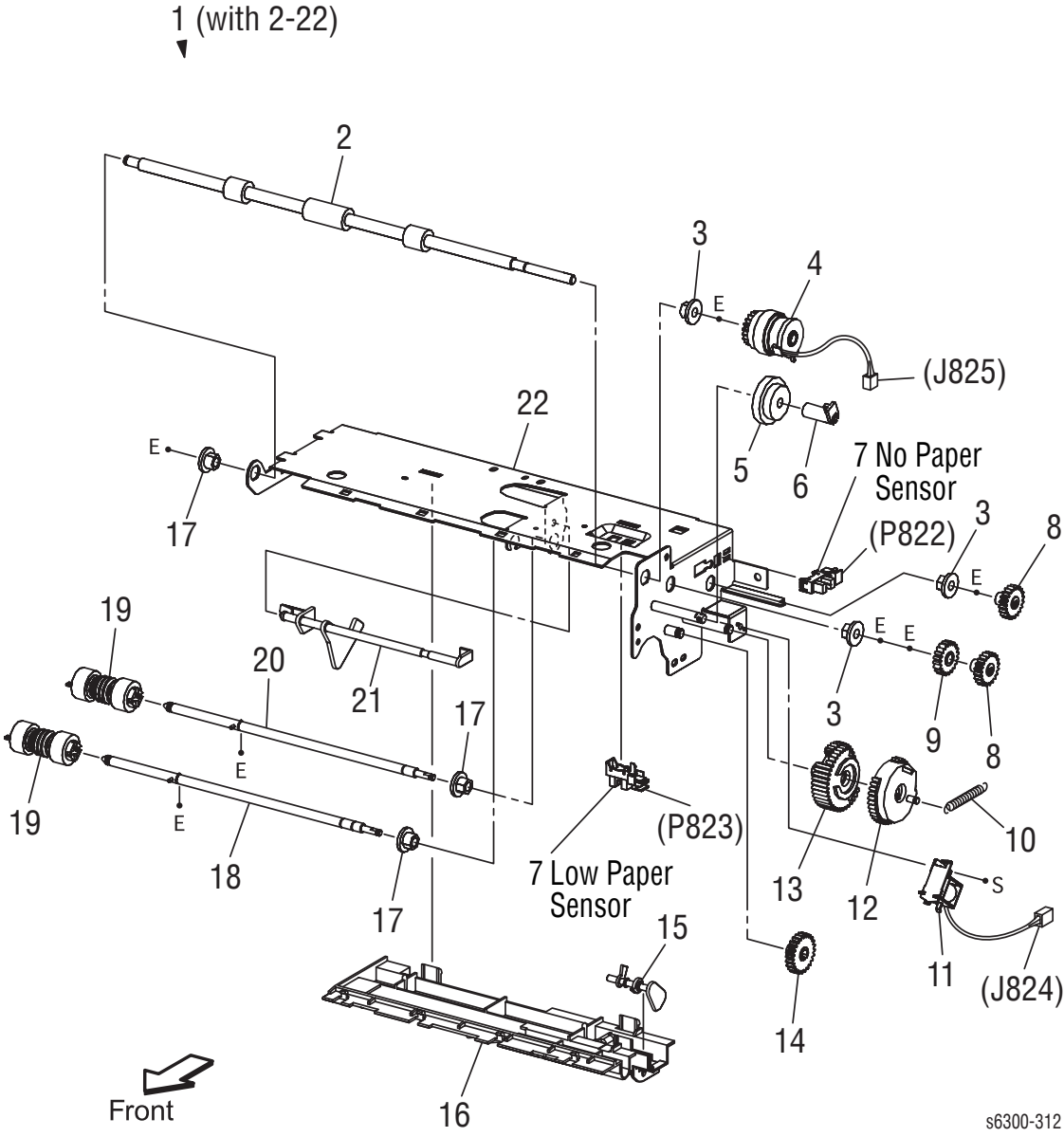

Parts List 12.4 Paper Pick Assembly HCF T1 - Service Parts List

| ID No. | Part Number | Name/Description |
|--------|-------------------------------|--|
| 1. | 116-2029-00 | Paper Pick (Pickup Assy) Assembly HCF T1 (with 2~22) |
| 2. | | Roll Assy Turn |
| 3. | | Bearing (F6xL8)/Metal |
| 4. | | Clutch Assy |
| 5. | | Gear Idle 21/29 |
| 6. | | Stopper Clutch |
| 7. | 116-1354-00 * | Sensor Photo (No Paper, Low Paper Sensor) |
| 8. | | Gear Feed2 |
| 9. | | Gear Idler Feed |
| 10. | Part of Spring Kit | Spring Feed H |
| 11. | | Solenoid Feed |
| 12. | | Gear Feed H2 |
| 13. | | Gear Feed H1 |
| 14. | | Gear 24 |
| 15. | Part of Actuator Kit | Actuator Low Paper |
| 16. | | Chute Upper |
| 17. | | Bearing (F6xL8)/Black |
| 18. | | Shaft Assy Feed |
| 19. | Part of Paper Feed Roller Kit | Roll Assy Nudger x 2 |
| 20. | | Shaft Assy Nudger |
| 21. | Part of Actuator Kit | Actuator No Paper |
| 22. | | Frame Assy Pickup |

Parts List 12.5 Paper Pick Assembly HCF T2

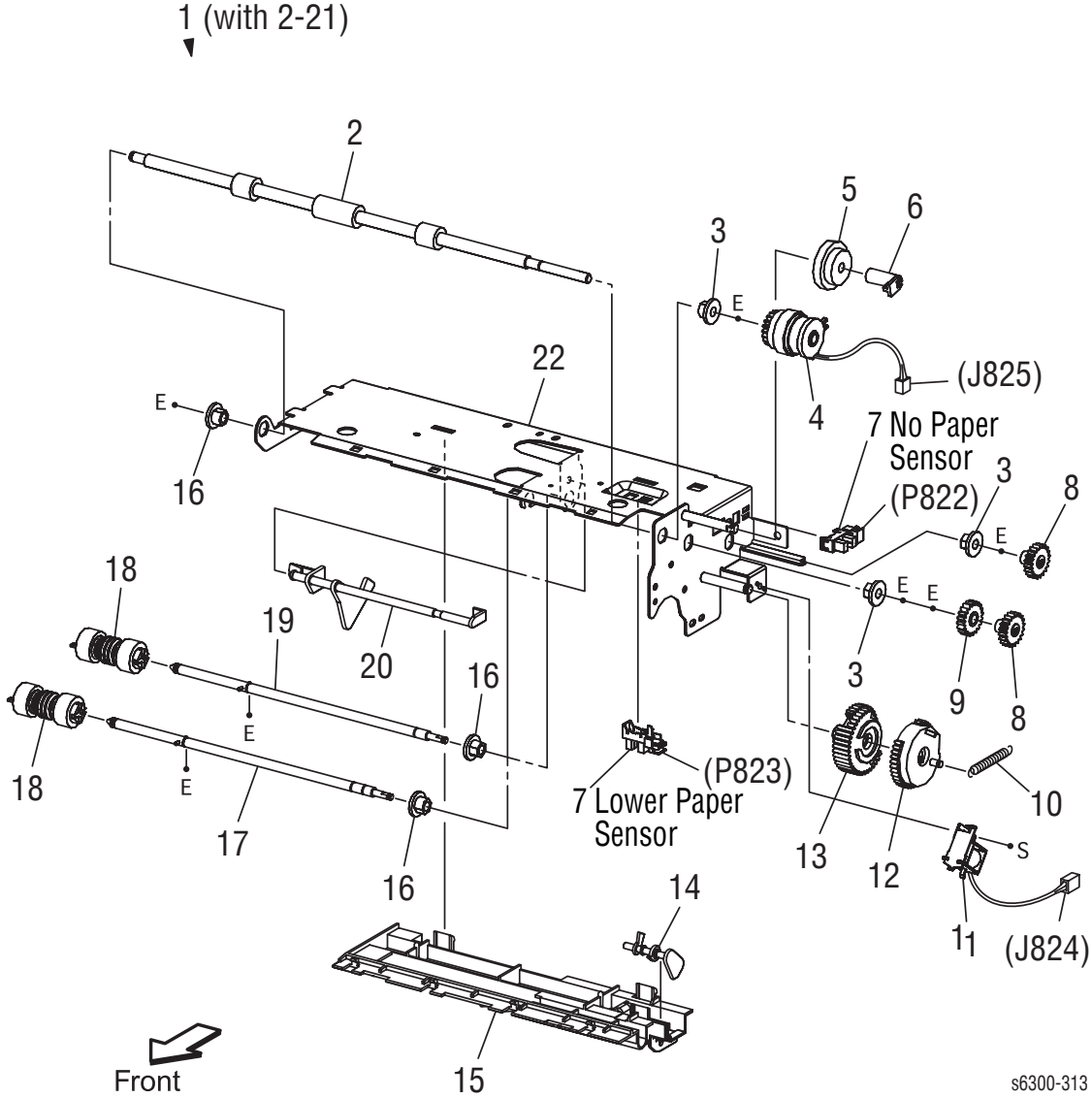

Parts List 12.5 Paper Pick Assembly HCF T2 - Service Parts List

| ID No. | Part Number | Name/Description |
|--------|-------------------------------|--|
| 1. | 116-2030-00 | Paper Pick (Pickup Assy) Assembly HCF T2 (with 2~21) |
| 2. | | Roll Assy Turn |
| 3. | | Bearing (F6xL8)/Metal |
| 4. | | Clutch Assy |
| 5. | | Gear Idle 21/29 |
| 6. | | Stopper Clutch |
| 7. | 116-1354-00 * | Sensor Photo (No Paper, Low Paper Sensor) |
| 8. | | Gear Feed2 |
| 9. | | Gear Idler Feed |
| 10. | | Spring Feed H |
| 11. | | Solenoid Feed |
| 12. | | Gear Feed H2 |
| 13. | | Gear Feed H1 |
| 14. | Part of Actuator Kit | Actuator Low Paper |
| 15. | | Chute Upper |
| 16. | | Bearing (F6xL8)/Black |
| 17. | | Shaft Assy Feed |
| 18. | Part of Paper Feed Roller Kit | Roll Assy Nudger x 2 |
| 19. | | Shaft Assy Nudger |
| 20. | Part of Actuator Kit | Actuator No Paper |
| 21. | | Frame Assy Pickup 4th |

Parts List 12.6 Universal Paper Tray

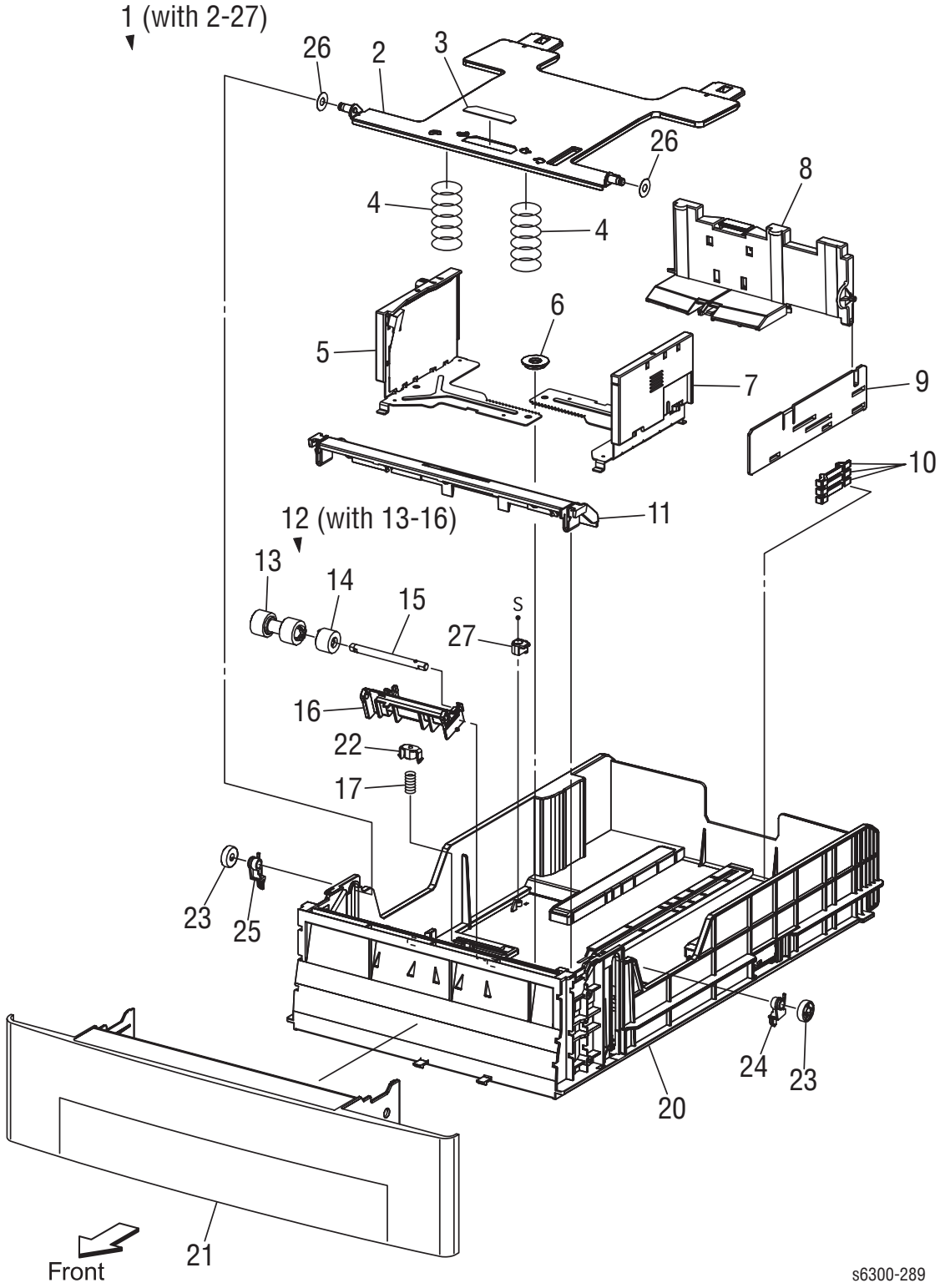

s6300-289

Parts List 12.6 Universal Paper Tray - Service Parts List

| ID No. | Part Number | Name/Description |
|--------|-------------------------------|---|
| 1. | 116-1976-00 | Universal Paper Tray (with 2~26) |
| 2. | | Plate Assy Btm |
| 3. | | Pad Bottom |
| 4. | | Spring N/F |
| 5. | | Guide Assy Side L |
| 6. | | Gear Manual |
| 7. | | Guide Assy Side R |
| 8. | | Guide Assy End |
| 9. | | Actuator Guide End |
| 10. | | Actuator Size |
| 11. | 116-1977-00 | Chute Turn |
| 12. | Part of Paper Feed Roller Kit | Universal Retard Roller Assy (with 13~16) |
| 13. | | Roll Assy Retard |
| 14. | | Clutch Assy Friction |
| 15. | | Shaft Assy Retard |
| 16. | | Holder Retard |
| 17. | | Spring Retard |
| 18. | | -- |
| 19. | | -- |
| 20. | | Housing Cst 500 |
| 21. | | Handle Cst |
| 22. | | Holder Spring Retard |
| 23. | | Roll PB |
| 24. | | Stopper Link PB R |
| 25. | | Stopper Link PB L |
| 26. | | Spacer Plate Btm |
| 27. | | Stopper Block |

Xerox Supplies and Accessories

Repair Kits, World Kits and Repacking Kits

| Description | Part Number |
|---|-------------|
| Kit, Spring | 116-2031-00 |
| Kit, Sensor Actuator | 116-2032-00 |
| Kit, Tray Holder | 116-2033-00 |
| Kit, Assorted Hardware (screws, E-rings) | 116-2034-00 |
| Kit, Paper Feed Roller | 116-2035-00 |
| Kit, Chute Assy Gear | 116-2039-00 |
| Kit, Harness | 116-2040-00 |
| World Kit | 061-4511-00 |
| Long-Life Maintenance Kit | 650-4363-00 |
| Main Shipping Box, Phaser 6300/6350 | 004-5506-00 |
| Repackaging Kit, Phaser 6300/6350 | 065-0637-00 |
| Repackaging Kit, High-Capacity Feeder, Phaser 6300/6350 | 065-0638-00 |
| Repackaging Kit, 550-Sheet Feeder, Phaser 6300/6350 | 065-0639-00 |
| Developer Assembly Shipping Restraint | 116-2043-00 |

Phaser 6300/6350 Maintenance Items

| Description | Part Number |
|-----------------------------------|-------------|
| Imaging Unit | 108R00645 |
| Fuser, Phaser 6300/6350 | |
| 110 V | 115R00035 |
| 220 V | 115R00036 |
| Transfer Roller | 108R00646 |
| Universal Paper Tray (2, 3, 4, 5) | 116-1976-00 |
| Paper Feed Roller Kit | 116-2035-00 |
| Long-Life Maintenance Kit | 650-4363-00 |

Power Cords

| Description | Part Number |
|-----------------------------------|-------------|
| Cable PWR, 115 V, 98, 0L | 161-0312-00 |
| Cable PWR EURO 220V , 99L | 161-0066-09 |
| Cable PWR U.K. 240 V, 96L | 161-0066-10 |
| Cable PWR AUST 240 V, 96L | 161-0066-11 |
| Cable Assy SWISS 220/240 V, 50 Hz | 161-0154-00 |
| Cable Assy PWR. DANISH, 250 V | 161-0240-00 |
| Cable Assy PWR, PRC | 161-0304-00 |
| Power, 240 V, ARGENTINA | 161-0307-00 |

Upgrade Kits and Options

| Description | Part Number |
|---|--------------|
| Internal Hard Drive | 650-4364-00 |
| Memory: | |
| 256 MB, 16M x 64, PC133; Memory DIMM | 856-0003-00 |
| 512 MB, 32M x 64, PC133; Memory DIMM | 856-0004-00 |
| 1100-Sheet Feeder w/ Trays | 119-6562-00 |
| 1100- Sheet Feeder Casters Non-Locking | 116-2054-00 |
| 1100- Sheet Feeder Casters Locking | 116-2055-00 |
| 550-Sheet Feeder w/ Tray | 119-6561-00 |
| Optional Feeder Label Kit (3, 4, and 5) | 116-2066-00 |
| Printer Feet | 116-1344-00 |
| Configuration Card, N configuration - Phaser 6300 Only | 163-1521-00 |
| Configuration Card, DN configuration - Phaser 6300 Only | 163-1525-00 |
| Configuration Card, DP configuration - Phaser 6350 Only | 163-1522-00 |
| I/P Board NVRAM | 163-1459-00* |

Toner Cartridge Consumables

| Description (capacity) | Part Number |
|---|-------------|
| Yellow Toner Cartridge, Standard-Capacity 6300/6350 (4K) | 106R01075 |
| Yellow Toner Cartridge, High-Capacity 6300 (7K) | 106R01084 |
| Yellow Toner Cartridge, High-Capacity 6350 (10K) | 106R01146 |
| Yellow Toner Cartridge, Metered 6300/6350 (10K) | 106R01088 |
| Magenta Toner Cartridge, Standard Capacity 6300/6350 (4K) | 106R01074 |
| Magenta Toner Cartridge, High-Capacity 6300 (7K) | 106R01083 |
| Magenta Toner Cartridge, High-Capacity 6350 (10K) | 106R01145 |
| Magenta Toner Cartridge, Metered 6300/6350 (10K) | 106R01087 |
| Cyan Toner Cartridge, Standard-Capacity 6300/6350 (4K) | 106R01073 |
| Cyan Toner Cartridge, High-Capacity 6300 (7K) | 106R01082 |
| Cyan Toner Cartridge, High-Capacity 6350 (10K) | 106R01144 |
| Cyan Toner Cartridge, Metered 6300/6350 (10K) | 106R01086 |
| Black Toner Cartridge, Standard-Capacity 6300/6350 (4K) | 106R01076* |
| Black Toner Cartridge, High-Capacity 6300 (7K) | 106R01085 |
| Black Toner Cartridge, High-Capacity 6350 (10K) | 106R01147 |
| Black Toner Cartridge, Metered 6300/6350 (10K) | 106R01089 |

Note

Toner Cartridges installed at the time of manufacture contain sufficient additional toner to prime the Auger Tubes without reducing the 4K life expectancy.

Service Kits

Service kits are developed to provide an easy means to obtain spare parts normally associated with larger assemblies. A number of Service Kits have been developed for the Phaser 6300/6350. The following tables list each kit's contents.

Feed Roller Kit

The Feed Roller Kit provides replacement rollers for the Paper Pick Assemblies and a universal Retard Roller Assembly.

Feed Roller Kit Contents - 116-2035-00

| Part Reference | Name/Description | Quantity |
|----------------|----------------------------------|----------|
| PL2.1.12 | Universal Retard Roller Assembly | 1 |
| PL3.3.18 | Feed Rollers | 2 |
| 071-0942-00 | Installation Instructions | 1 |

Spring Kit

Spring Kit Contents - 116-2031-00

| Part Reference | Name/Description | Quantity |
|----------------|-------------------------------------|----------|
| PL3.3.10 | Feed Spring H | 2 |
| PL4.1.2 | Registration Roller Spring | 1 |
| PL5.1.6 | Link Spring | 1 |
| PL5.2.3 | Fuser Lock Lever Spring | 1 |
| PL5.2.7 | Diode Spring F | 1 |
| PL5.2.12 | Latch Spring | 1 |
| PL5.2.18 | CTD (ADC) Sensor Spring | 1 |
| PL5.2.22 | DTC Bias Spring | 1 |
| PL5.3.4 | IDT1-1 Bias Spring | 1 |
| PL5.3.8 | MPT Feed Spring | 1 |
| PL5.3.11 | MPT N/F Spring | 1 |
| PL5.3.33 | Earth Out2 Spring | 1 |
| PL5.3.34 | MPT No Paper Sensor Actuator Spring | 1 |
| PL5.4.3 | Exit Pinch Roller Springs | 2 |
| PL5.4.14 | Duplex Jam Sensor Actuator Spring | 1 |
| PL6.1.4 | Stopper Lever Release Spring | 1 |

Sensor Acuator Kit

The Sensor Actuator Kit provides replacement actuators for the key paper path sensors. Replacement springs for most of these actuators are included in the Kit.

Sensor Actuator Kit Contents - 116-2032-00

| Part Reference | Name/Description | Quantity |
|----------------|---------------------------------------|----------|
| PL3.3.14 | Low Paper Sensor Actuator | 2 |
| PL3.3.20 | No Paper Sensor Actuator | 2 |
| PL4.1.1 | Registration Sensor Actuator | 1 |
| PL5.1.2 | Fuser Exit Sensor Actuator | 1 |
| PL5.3.15 | Tray 1 (MPT) No Paper Sensor Actuator | 1 |
| PL5.4.2 | Full Stack Sensor Actuator | 1 |
| PL5.4.13 | Duplex Jam Sensor Actuator | 1 |

Long-Life Maintenance Kit

Install the Long-Life Maintenance Kit when the printer displays the Replace Maintenance Kit error message.

Long-Life Maintenance Kit Contents - 650-4363-00

| Part Reference | Part Number | Name/Description | Quantity |
|----------------|-------------|---------------------------------------|----------|
| PL2.1.12 | 116-2035-00 | Universal Tray Retard Roller Assembly | 1 |
| PL4.1.13 | 116-1985-00 | Tray 1 (MPT) Retard Roller Assembly | 1 |
| PL4.2.1 | 116-1987-00 | Registration Roller Assembly | 1 |
| PL5.3.20 | 116-1997-00 | Tray 1 (MPT) Feed Roller | 1 |
| PL7.1.17 | 116-2008-00 | Developer Assembly - Y | 1 |
| PL7.1.18 | 116-2009-00 | Developer Assembly - M | 1 |
| PL7.1.19 | 116-2010-00 | Developer Assembly - C | 1 |
| PL7.1.20 | 116-2011-00 | Developer Assembly - K | 1 |

Hardware Kit

Hardware Kit Contents - 116-2034-00

| Part Number | Name/Description | Quantity |
|--------------------|-------------------------|-----------------|
| 112W27678 | Screw Deltite S | 4 |
| 112W27698 | SEMS Machine Screw | 2 |
| 158W35878 | Screw DEL TP | 2 |
| 153W17888 | Screw Tap WP | 2 |
| 153W27878 | Screw-Tap BIND | 4 |
| 153W28078 | Screw-Tap BIND | 8 |
| 826E10100 | Screw Set | 2 |
| 826E12480 | Screw M3X6B | 6 |
| 826E12570 | Screw-DT FL4X10J | 2 |
| 826E12580 | Screw Round Tip | 2 |
| 354W21278 | E-ring | 2 |
| 354W24251 | E-ring | 2 |
| 354W24254 | KL-ring | 2 |
| 354W27278 | E-ring | 4 |

Harness Kit

Harness Kit Contents - 116-2040-00

| Part Reference | Name/Description | Quantity |
|----------------|--|----------|
| PL3.2.11 | Harness Assy OPFPLG (J17-P171) | 1 |
| PL3.3.22 | Harness Assy FDR (J47-J471,J472,J473,P474) | 1 |
| PL4.1.21 | Harness Assy FRONTCLH (J19-J191,J192) | 1 |
| PL5.2.28 | Harness Assy FSR/ADC (J36-J136,J162,J361) | 1 |
| PL5.2.30 | Harness Assy TNRFULL/FSR (J52-J142,J521) | 1 |
| PL5.3.28 | Harness Assy FRONT/DUP (J13-P132, J133, J134, J135, P501) | 1 |
| PL7.2.18 | Harness Assy TNR (J51-J342, P511, P512, P513, P514, J701,J702,J703,J704) | 1 |
| PL10.1.1 | Harness Assy 24V (J60-J163) | 1 |
| PL10.1.2 | Harness Assy LV (J61-J165) | 1 |
| PL10.1.3 | Harness Assy LV RPG (J164-J311) | 1 |
| PL10.1.4 | Harness Assy TMP (J24-J231) | 1 |
| PL10.1.5 | Harness Assy HVPS (J16-J141) | 1 |
| PL10.1.6 | Wire Assy BTR (J138-J139) | 1 |
| PL10.1.7 | Wire Assy Regi (J137-J140) | 1 |
| PL10.1.8 | Harness Assy EEPROM (J191-J1911) | 1 |
| PL10.1.9 | Harness Assy FAN/PHD/MOT (J48-J481, J482, J484, J491) | 1 |
| PL11.1.6 | Harness Assy OPFREC (J83-P171) | 1 |
| PL12.3.1 | Harness Assy OPFREC2 (J83-J172) | 1 |

Wiring Diagrams

In this chapter...

- Plug/Jack Designators
- Plug/Jack Locators
- Wiring Diagrams

Section 10

Plug/Jack Locator Diagrams

The P/J Locator diagrams show the location of primary connections within the printer and optional sheet feeders. Use these illustrations to locate connections called out in the troubleshooting procedures presented in Sections 3, 4, and 5.

To find the location of a Plug or Jack:

1. Locate the P/J connector designator in the first column of the table.
2. With this information, go to the map listed in the second column.
3. Use the coordinates to quickly locate the connection indicated on the map with its P/J designation number.

Print Engine Plug/Jack Designators

Print Engine Plug/Jack Designators

| P/J | Map | Coordinates | Remarks |
|-----|-----|-------------|--|
| 13 | 3 | H-143 | Connects the Engine Control Board and FRONT/DUP Harness. |
| 14 | 3 | G-142 | Connects the Engine Control Board and Image Processor Board. |
| 15 | 3 | F-142 | Connects the Engine Control Board and Laser Unit Harness. |
| 16 | 3 | F-142 | Connects the Engine Control Board and HVPS Harness. |
| 17 | 3 | I-143 | Connects the Engine Control Board and OPFPLG Harness. |
| 18 | 3 | F-143 | Connects the Engine Control Board and REGI SNS Harness. |
| 19 | 3 | F-143 | Connects the Engine Control Board and FRONTCLH Harness. |
| 20 | 3 | F-143 | Not Connected |
| 21 | 3 | E-142 | Not Connected |
| 22 | 3 | I-143 | Connects the Engine Control Board and OPEPANE2 Harness. |
| 24 | 3 | E-142 | Connects the Engine Control Board and TMP Harness. |
| 30 | 3 | E-142 | Flash Write |
| 31 | 3 | F-142 | Test Print |
| 34 | 3 | F-142 | Connects the Engine Control Board and RFID Harness. |
| 36 | 3 | H-143 | Connects the Engine Control Board and FSR/ADC Harness. |
| 47 | 3 | H-143 | Connects the Engine Control Board and Feeder Harness. |
| 48 | 3 | H-143 | Connects Engine Control Board and FAN/PHD/MOT Harness. |
| 51 | 3 | H-143 | Connects the Engine Control Board and Toner Harness. |
| 52 | 3 | H-143 | Connects Engine Control Board and TNRFULL/FSR Harness. |
| 60 | 3 | I-143 | Connects the Engine Control Board and 24 V Harness. |

Print Engine Plug/Jack Designators (Continued)

| P/J | Map | Coordinates | Remarks |
|-----|-----|-------------|--|
| 61 | 3 | H-143 | Connects the Engine Control Board and LV Harness. |
| 120 | 3 | G-137 | Connects the Engine Control and Image Processor Boards. |
| 132 | 1 | H-109 | Connects the Tray 1 Feed Solenoid and FRONT/DUP Harness. |
| 133 | 1 | D-108 | Connects the Duplex Jam Sensor and FRONT/DUP Harness. |
| 134 | 1 | F-106 | Connects the Full Stack Sensor and FRONT/DUP Harness. |
| 135 | 1 | E-109 | Connects Tray 1 No Paper Sensor and FRONT/DUP Harness. |
| 136 | 2 | D-122 | Connects the CTD (ADC) Sensor and FSR/ADC Harness. |
| 137 | 3 | B-137 | Connects the Wire Assy Regi to the Registration Roller Assy. |
| 138 | 3 | B-136 | Connects the Wire Assembly BTR to the Transfer Roller. |
| 139 | 3 | E-133 | Connects the HVPS and Wire Assembly BTR. |
| 140 | 3 | E-133 | Connects the HVPS and Wire Assembly Regi. |
| 141 | 3 | E-135 | Connects the HVPS and HVPS Harness. |
| 142 | 2 | E-122 | Connects the Toner Full Sensor and TNR FULL/FSR Harness. |
| 144 | 2 | H-121 | Connects the EEPROM Board and EEPROM Harness. |
| 151 | 2 | H-120 | Connects the Laser Unit and ROS Harness. |
| 154 | 3 | F-142 | Not Connected |
| 160 | 2 | I-128 | Connects the LVPS and AC Inlet. |
| 161 | 2 | I-126 | Connects the LVPS and Interlock Switch. |
| 162 | 2 | I-128 | Connects the LVPS and FSR/ADC Harness. |
| 163 | 2 | I-126 | Connects the LVPS and 24 V Harness. |
| 164 | 2 | I-127 | Connects the LVPS and LV PRG Harness. |
| 165 | 2 | I-127 | Connects the LVPS and LV Harness. |
| 166 | 2 | I-126 | Connects the LVPS and Rear Fan. |
| 167 | 2 | I-126 | Not Connected |
| 171 | 4 | G-154 | Connects the Option Feeder and OPFPLG Harness. |
| 181 | 3 | E-138 | Connects the Registration Sensor and REGI SNS Harness. |
| 190 | 3 | F-138 | Connects the Tray 1 (MPT) Turn Clutch and FRONTCLH. |
| 191 | 3 | G-143 | Connects the Engine Control Board and EEPROM Harness. |
| 192 | 3 | F138 | Connects the Registration Clutch and FRONTCLH Harness. |
| 220 | 1 | C-106 | Connects the Control Panel and Control Panel Harness. |
| CN1 | 4 | B-153 | Connects the Temperature/Humidity Sensor and TMP Harness. |
| 311 | 3 | G-142 | Connects the Engine Control Board and LV RPG Harness. |

Print Engine Plug/Jack Designators (Continued)

| P/J | Map | Coordinates | Remarks |
|------------|------------|--------------------|---|
| 341 | 1 | E-105 | Connects the CRUM Antenna and RFID2 Harness. |
| 342 | 1 | E-105 | Connects the CRUM Antenna and TNR Harness. |
| 361 | 2 | F-122 | Connects the Fuser and FSR/ADC Harness. |
| 471 | 4 | H-154 | Connects the Paper Size Switch and FDR Harness. |
| 472 | 4 | G-153 | Connects the No Paper Sensor and FDR Harness. |
| 473 | 4 | F-153 | Connects the Low Paper Sensor and FDR Harness. |
| 474 | 4 | G-153 | Connects the Feed Solenoid and FDR Harness. |
| 481 | 2 | G-123 | Connects the Main Motor and FAN/PHD/MOT Harness. |
| 482 | 1 | E-107 | Connects the Fuser Fan and FAN/PHD/MOT Harness. |
| 484 | 2 | E-119 | Connects the PHD2 Harness and FAN/PHD/MOT Harness. |
| 491 | 2 | H-123 | Connects the Developer Motor and FAN/PHD/MOT Harness. |
| 501 | 1 | C-107 | Connects the Duplex Motor and FRONT/DUP Harness. |
| 511 | 1 | H-106 | Connects the Toner Motor (Y) and TNR Harness. |
| 512 | 1 | I-106 | Connects the Toner Motor (M) and TNR Harness. |
| 513 | 1 | I-106 | Connects the Toner Motor (C) and TNR Harness. |
| 514 | 1 | J-106 | Connects the Toner Motor (K) and TNR Harness. |
| 521 | 2 | F-123 | Connects the Fuser Motor and TNRFULL/FSR Harness. |
| 701 | 1 | G-106 | Connects the No Toner Sensor (Y) and TNR Harness. |
| 702 | 1 | H-106 | Connects the No Toner Sensor (M) and TNR Harness. |
| 703 | 1 | H-106 | Connects the No Toner Sensor (C) and TNR Harness. |
| 704 | 1 | I-105 | Connects the No Toner Sensor (K) and TNR Harness. |
| 710 | 2 | D-119 | Connects the CRUM and PHD2 Harness. |
| 910 | 3 | H-136 | Serial Debug Port |
| 920 | 3 | I-137 | Mode Select Port |
| 3411 | 1 | F-106 | Connects the RFID2 Harness and RFID Harness. |

Print Engine Plug/Jack Locators

The following maps indicate the location of key connections within the printer. Connections are referenced by their P/J designation.

Map 1 - Xerographics

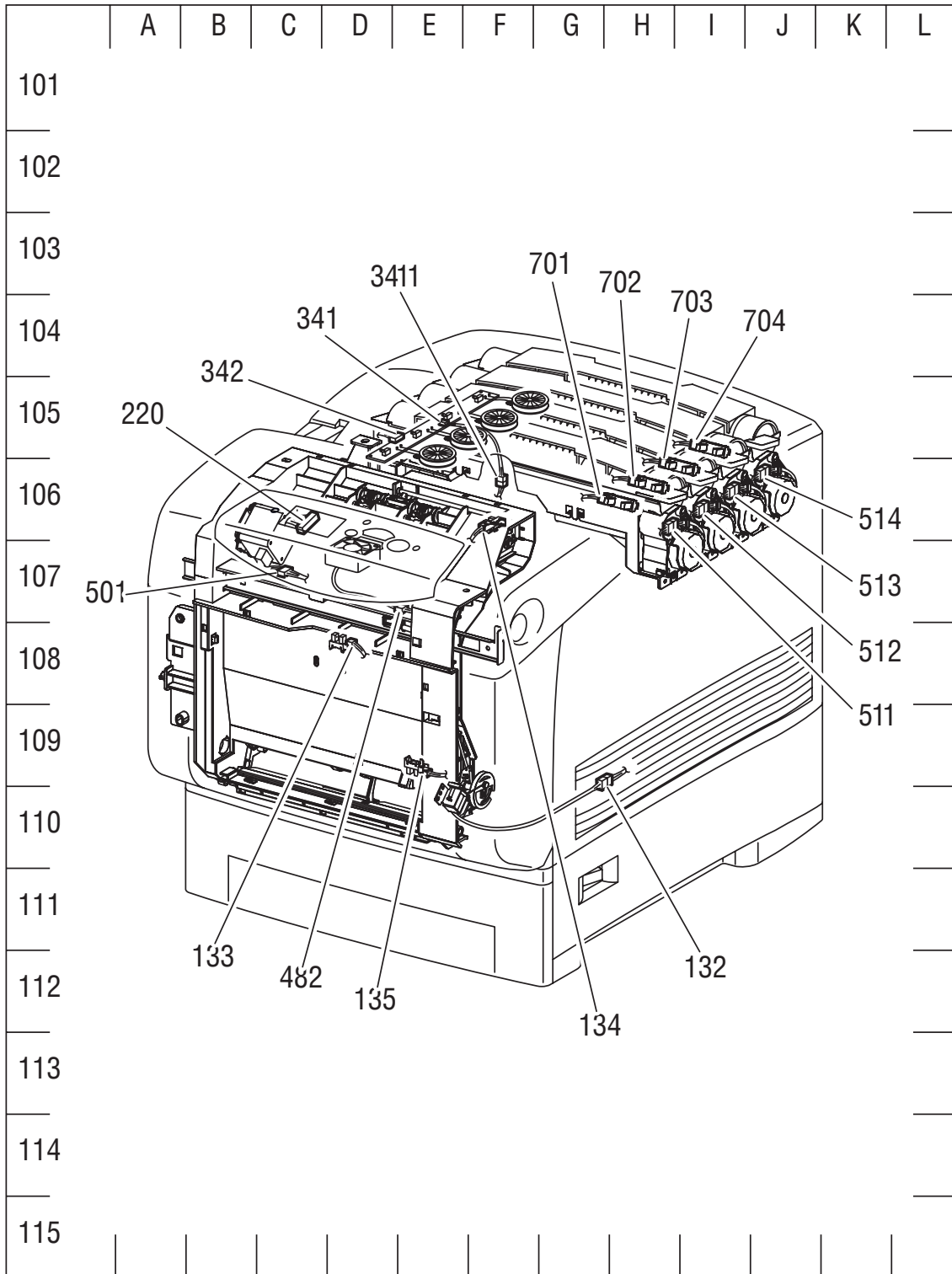

s6300-315

Map 2 - LVPS and Drive

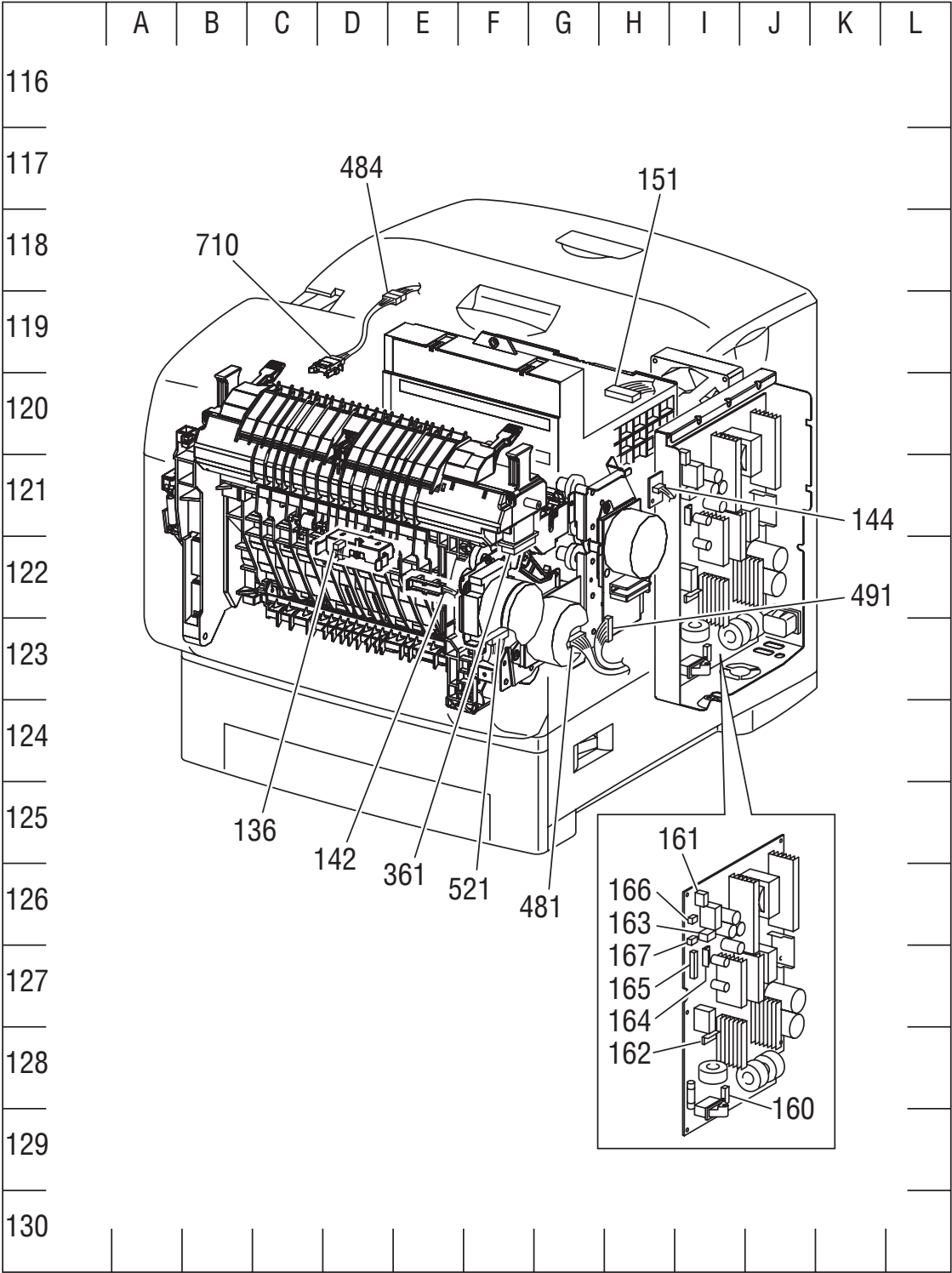

s6300-316

Map 3 - Engine Control Board

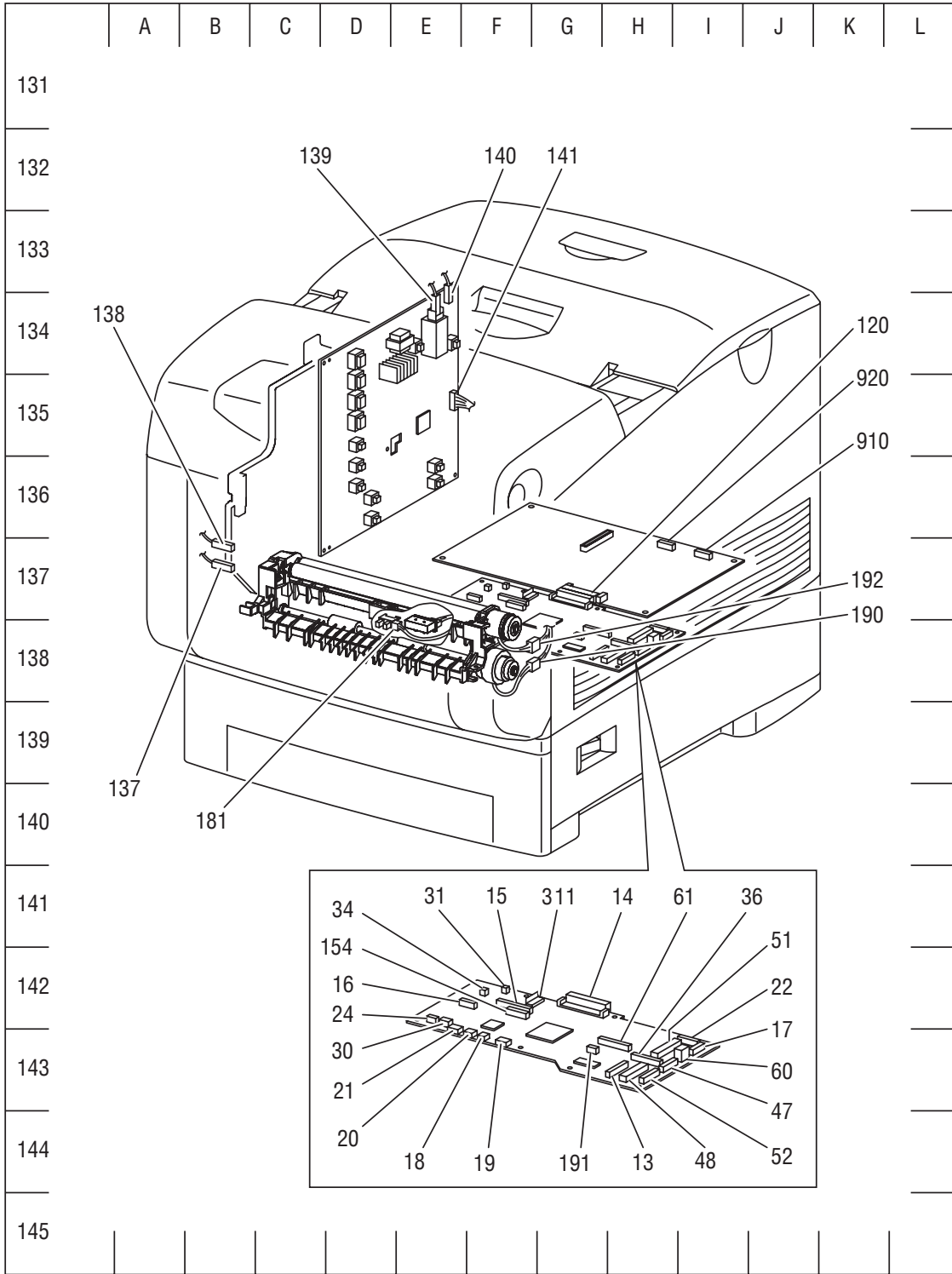

s6300-317

Map 4 - Tray 2 Paper Pick Assembly

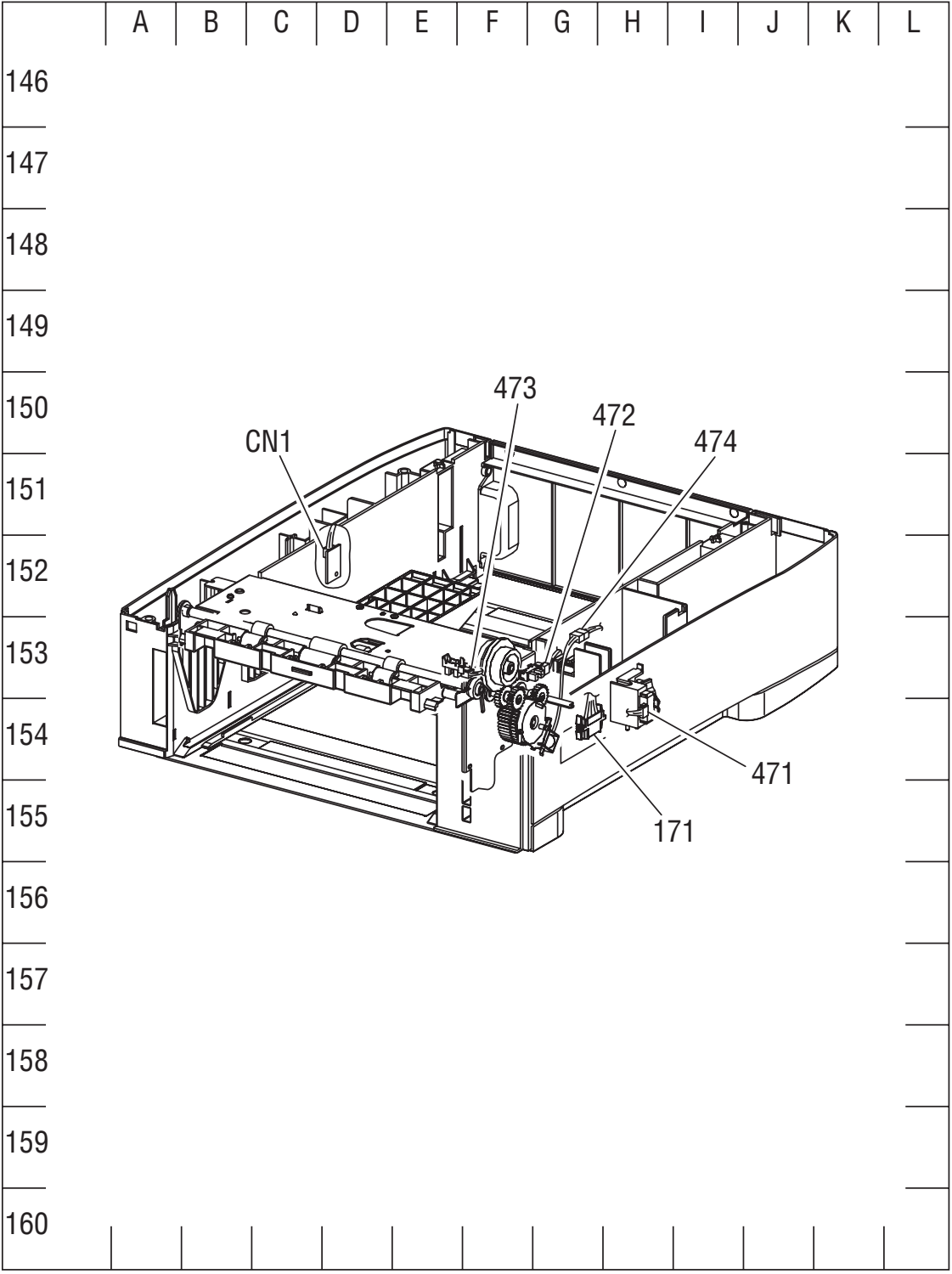

s6300-318

1100-Sheet Feeder Plug/Jack Designators

1000-Sheet Feeder Plug/Jack Designators

| P/J | Coordinates | Remarks |
|-------------------|-------------|--|
| Upper Tray | | |
| 80 | I-303 | Connects the Upper OPTFDR Board and SIZE2 Harness. |
| 81 | J-303 | Connects the Upper OPTFDR Board and LOWP Harness. |
| 82 | J-303 | Connects the Upper OPTFDR Board and Drive Assembly. |
| 83 | J-303 | Connects the Upper OPTFDR Board and OPFREC2 Harness. |
| 84 | J-303 | Connects the Upper OPTFDR Board and OPF23 Harness. |
| 85 | J-303 | Connects the Upper OPTFDR Board and OPFDR2 Harness. |
| 86 | J-303 | Not Connected |
| 172 | G-306 | Connects to Print Engine or Option Tray Module |
| 821 | H-307 | Connects the Paper Size Switch and SIZE2 Harness. |
| 822 | G-307 | Connects the No Paper Sensor and OPFDR2 Harness. |
| 823 | F-307 | Connects the Low Paper Sensor and LOWP Harness. |
| 824 | H-308 | Connects the Feed Solenoid and OPFDR2 Harness. |
| 825 | F-308 | Connects the Turn Clutch and OPFDR2 Harness. |
| Lower Tray | | |
| 80 | I-312 | Connects the Lower OPTFDR Board and SIZE2 Harness. |
| 81 | J-311 | Connects the Lower OPTFDR Board and LOWP Harness. |
| 82 | J-312 | Not Connected |
| 83 | J-312 | Connects the Lower OPTFDR Board and OPF23 Harness. |
| 84 | J-311 | Not Connected |
| 85 | J-312 | Connects the Lower OPTFDR Board and OPFDR2 Harness. |
| 86 | J-312 | Not Connected |
| 821 | H-309 | Connects the Paper Size Switch and SIZE2 Harness. |
| 822 | G-308 | Connects the No Paper Sensor and OPFDR2 Harness. |
| 823 | F-308 | Connects the Low Paper Sensor and LOWP Harness. |
| 824 | H-309 | Connects the Feed Solenoid and OPFDR2 Harness. |
| 825 | F-310 | Connects the Turn Clutch and OPFDR2 Harness. |

1100-Sheet Feeder Plug/Jack Locator

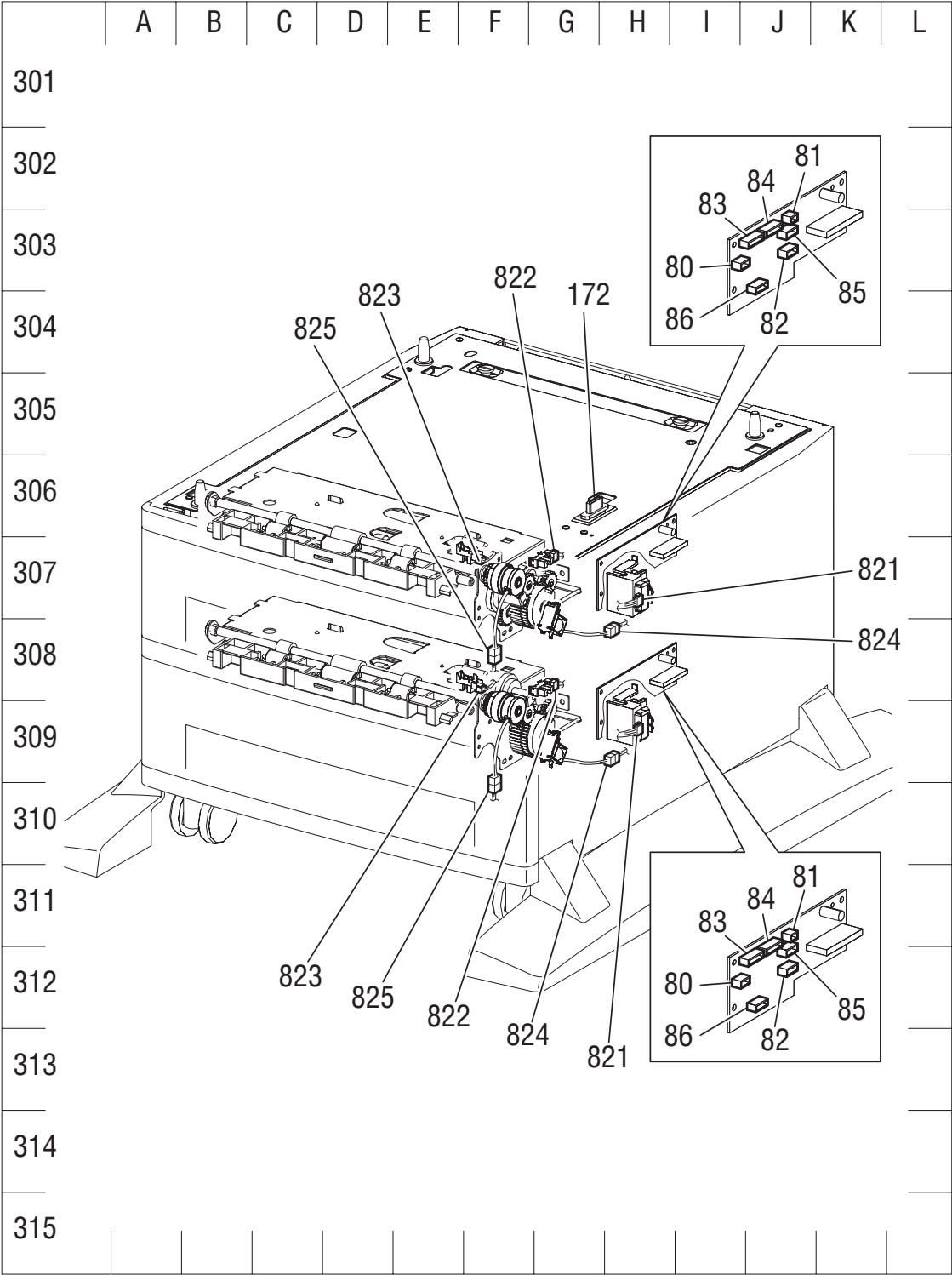

s6300-335

550-Sheet Feeder Plug/Jack Designators

550-Sheet Feeder Plug/Jack Designators

| P/J | Coordinates | Remarks |
|------------|--------------------|---|
| 80 | I-205 | Connects the OPTFDR Board and SIZE Harness. |
| 81 | J-204 | Connects the OPTFDR Board and LOWP Harness. |
| 82 | J-205 | Connects the OPTFDR Board and Drive Assembly. |
| 83 | I-205 | Connects the OPTFDR Board and OPFREC Harness. |
| 84 | I-205 | Connects the OPTFDR Board and OPFPLG2 Harness. |
| 85 | J-204 | Connects the OPTFDR Board and OPFDR Harness. |
| 86 | I-205 | Not Connected |
| 171 | G-208 | Connects the Optional Feeder to the Print Engine. |
| 172 | G-210 | Connects the Optional Feeders. |
| 821 | H-209 | Connects the Paper Size Switch and SIZE2 Harness. |
| 822 | G-209 | Connects the No Paper Sensor and OPFDR2 Harness. |
| 823 | F-209 | Connects the Low Paper Sensor and LOWP Harness. |
| 824 | H-209 | Connects the Feed Solenoid and OPFDR2 Harness. |
| 825 | G-209 | Connects the Turn Clutch and OPFDR2 Harness. |

550-Sheet Feeder Plug/Jack Locator

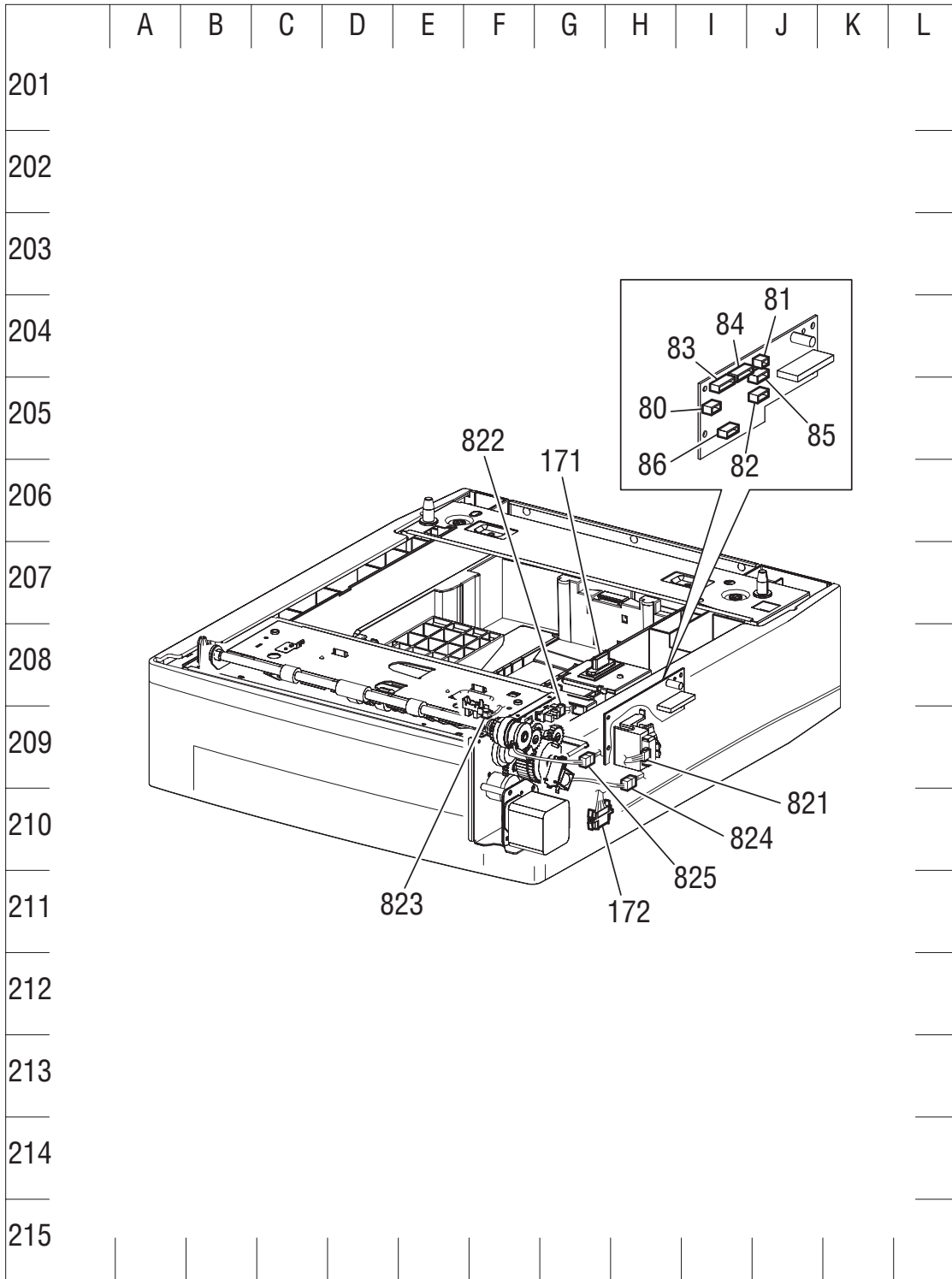





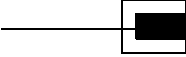
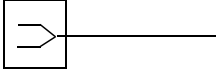
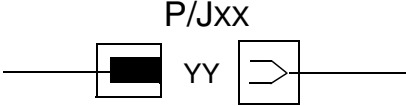

s6300-331

Wiring Diagrams

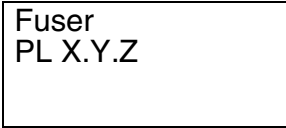
Notations Used in Wiring Diagrams

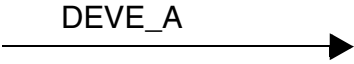
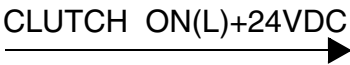
The following describes the legend used in the wiring diagrams shown on the following pages.

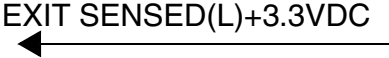
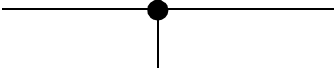
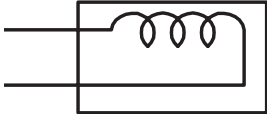
| Symbol | Description |
|---|---|
|  | Denotes a plug. |
|  | Denotes a jack. |
|  | Denotes Pin yy and Jack yy of the connector Pxx and Jxx. |
|  | Denotes a Jumper Point (JPxxx/xxx). Each end of the Jumper connection has a numeric designation. |
|  | Denotes the parts. PL X.Y.Z implies the item "Z" of plate (PL) "X.Y" in Parts List. |
|  | Denotes functional parts attached with functional parts name. |
|  | Denotes the control and its outline in PWB. |
|  | Denotes a connection between parts with harnesses or wires, attached with signal name/contents. |
|  | Denotes the function, and logic value of the signal to operate the function (Low: L, High: H). The given voltage is for signal in high status. The arrow indicates the direction of signal. |

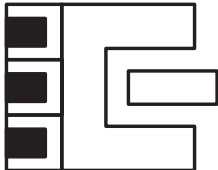
| Symbol | Description |
|--|---|
|  | <p>Denotes the function, and logic value of the signal when the function operated (Low: L, High: H). The given voltage is for signal in high status. The arrow indicates the direction of signal.</p> |
|  | <p>Denotes a connection between wires.</p> |
|  | <p>Denotes a Clutch or Solenoid.</p> |
|  | <p>Denotes a Motor.</p> |
|  | <p>Denotes a photo sensor.</p> |
| <p>I/L +24VDC</p> | <p>Denotes DC voltage when the interlock switch in Engine Control Board turns on.</p> |
| <p>+5VDC +3.3VDC</p> | <p>Denotes DC voltage.</p> |
| <p>SG</p> | <p>Denotes signal ground.</p> |

Print Engine Wiring Diagrams

Print Engine General Wiring (1/2)

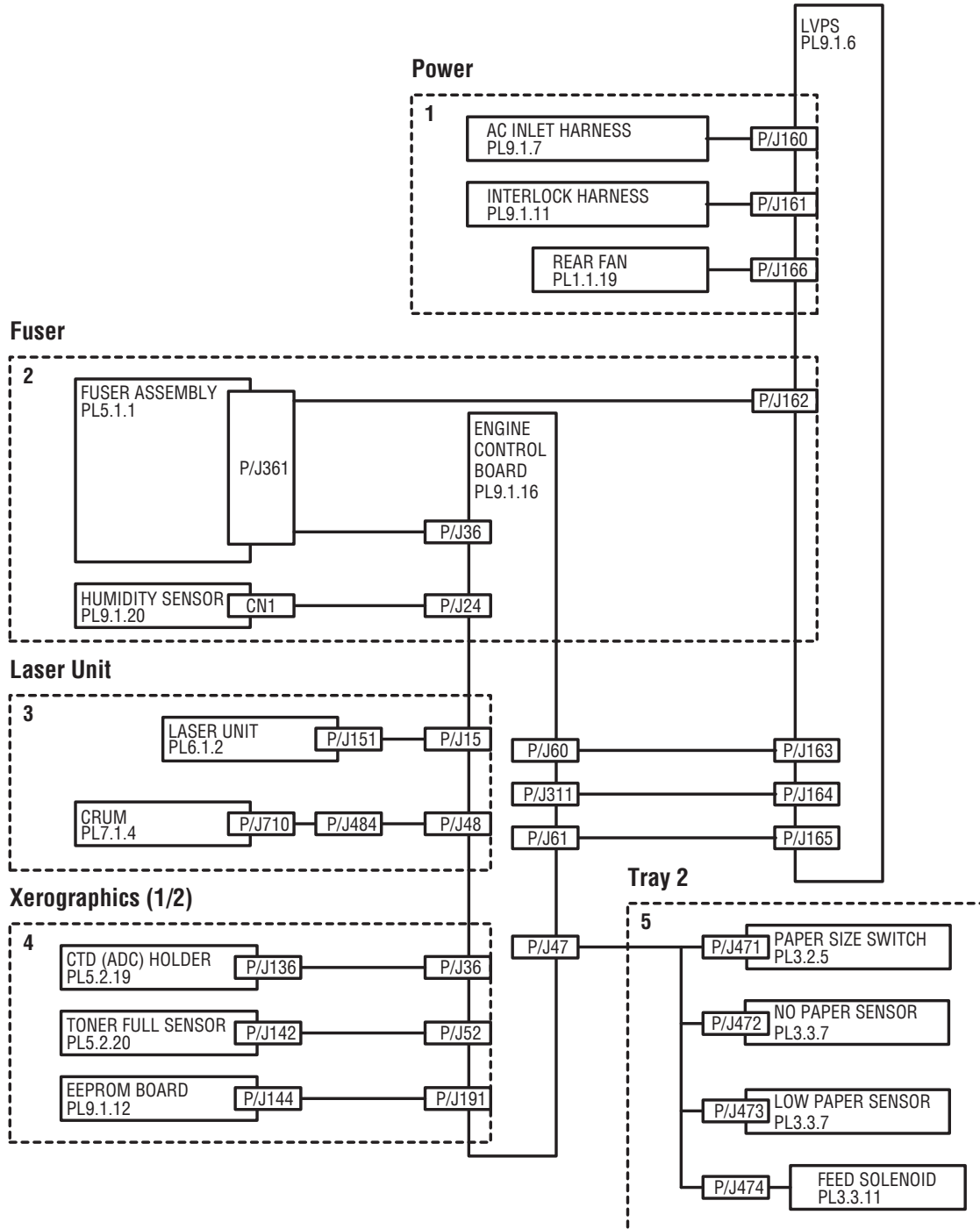

s6300-348

Print Engine General Wiring (2/2)

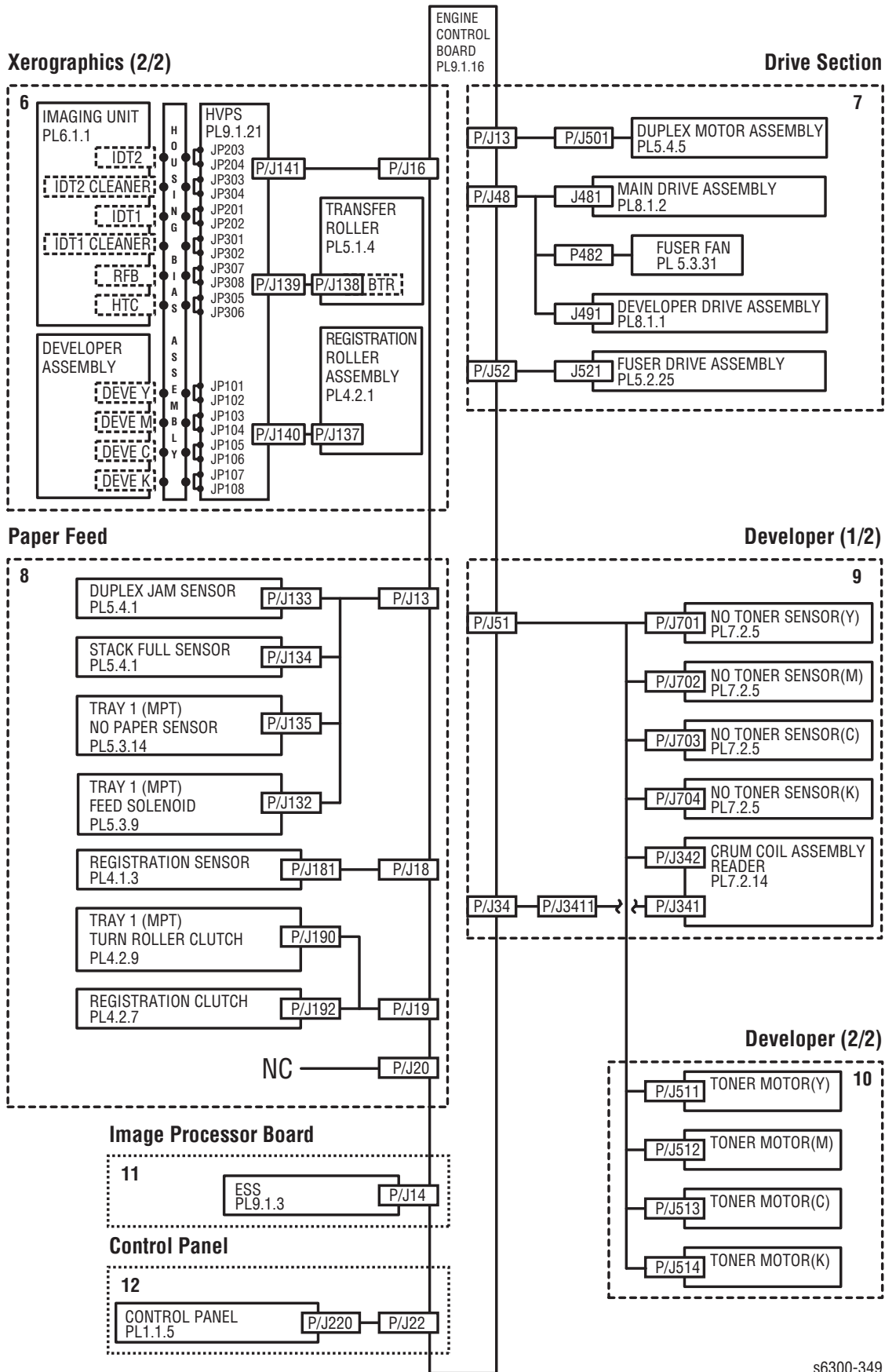

s6300-349

Tray 2

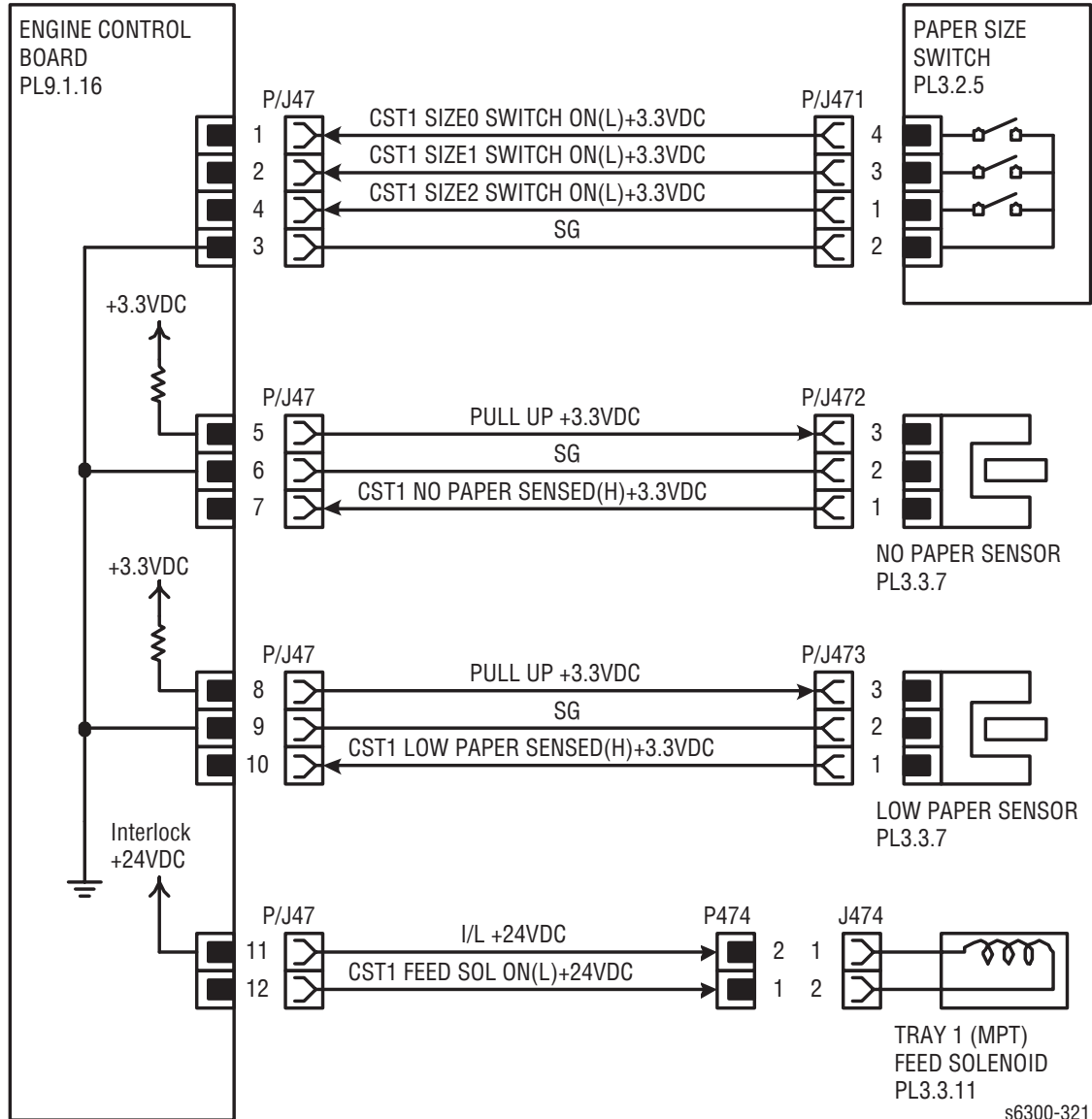

s6300-321

Drive Section

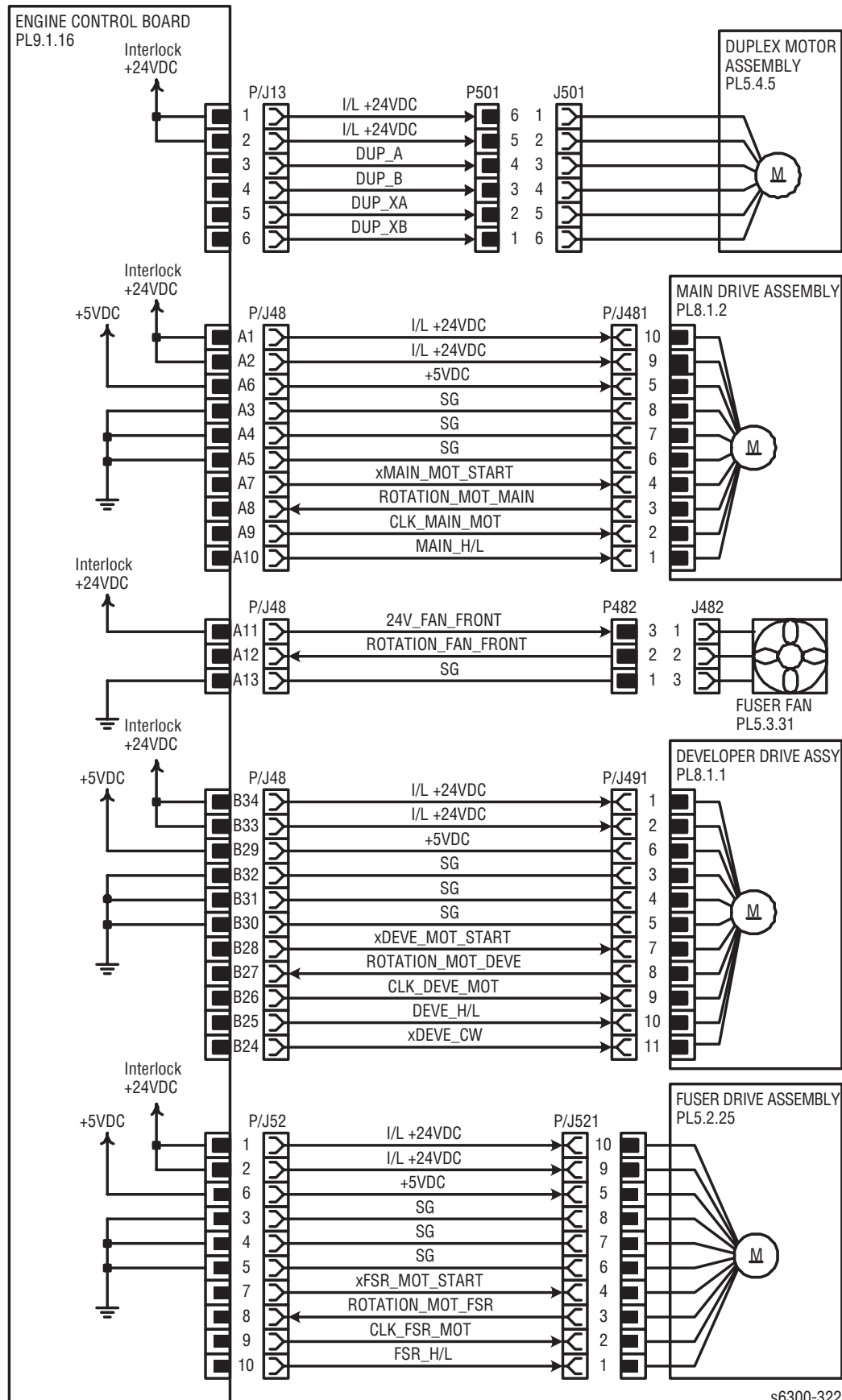

s6300-322

Developer (2/2)

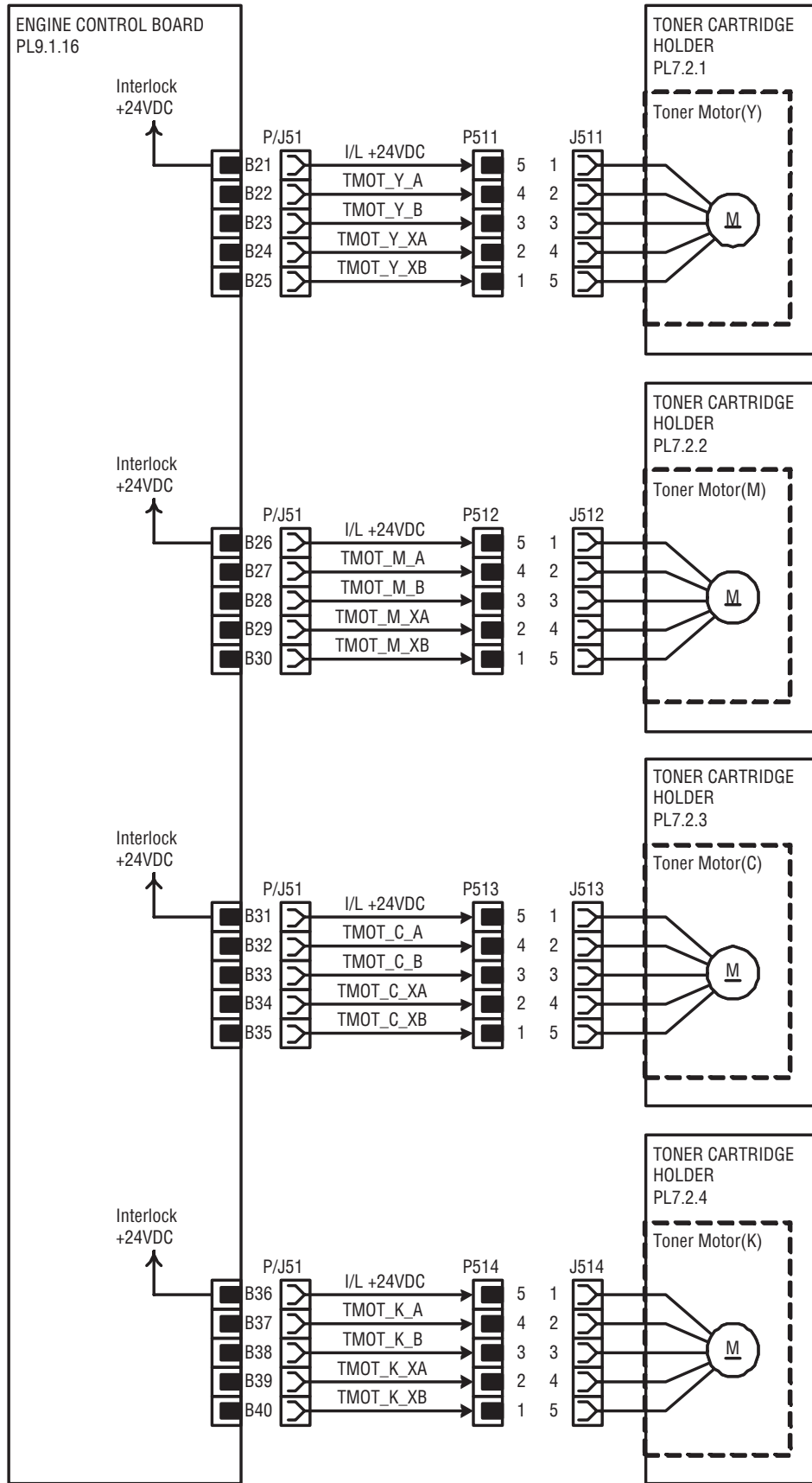

s6300-324

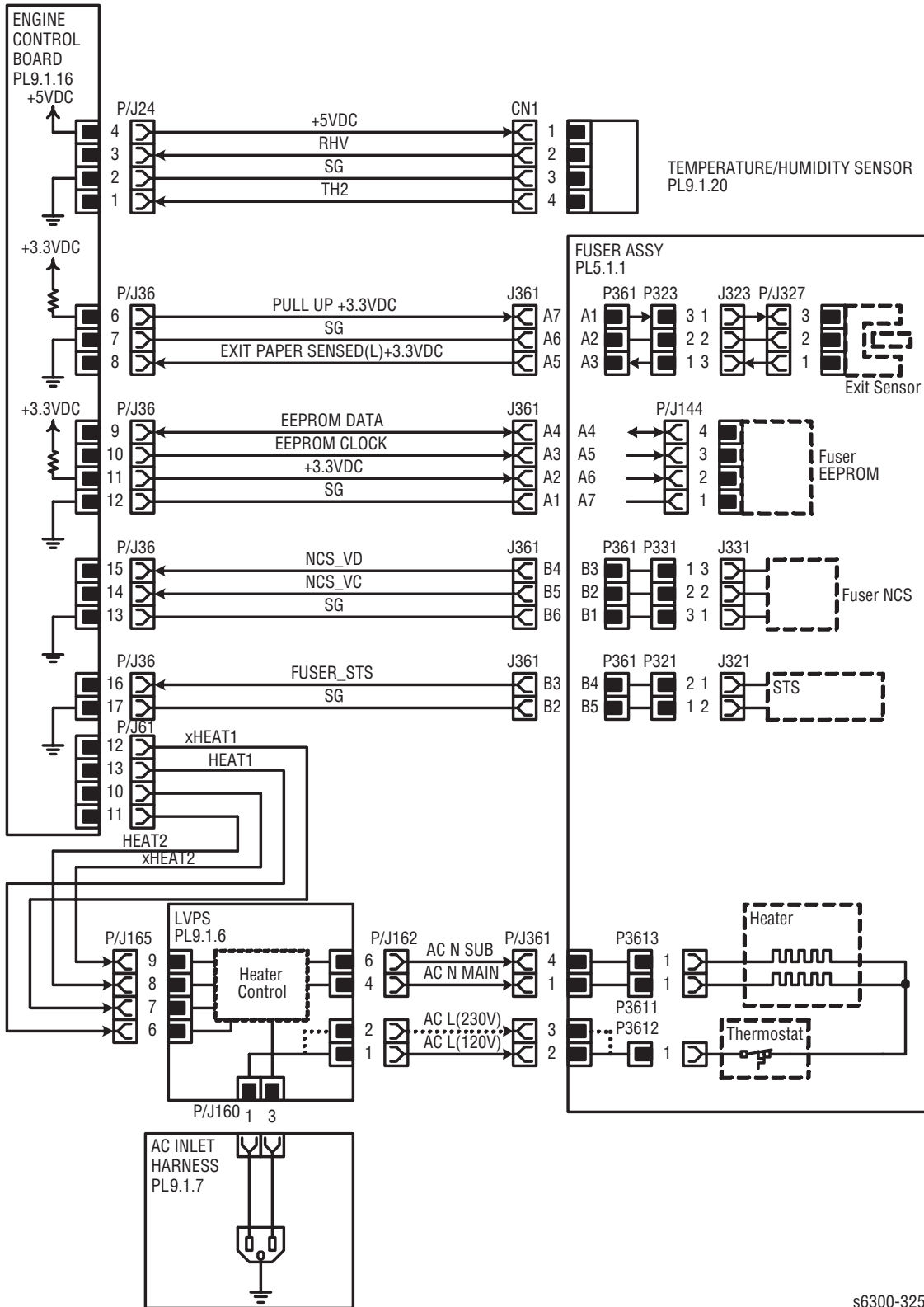

s6300-325

Note: P/J numbers within the Fuser block are all internal to the Fuser Assembly.

Laser Unit

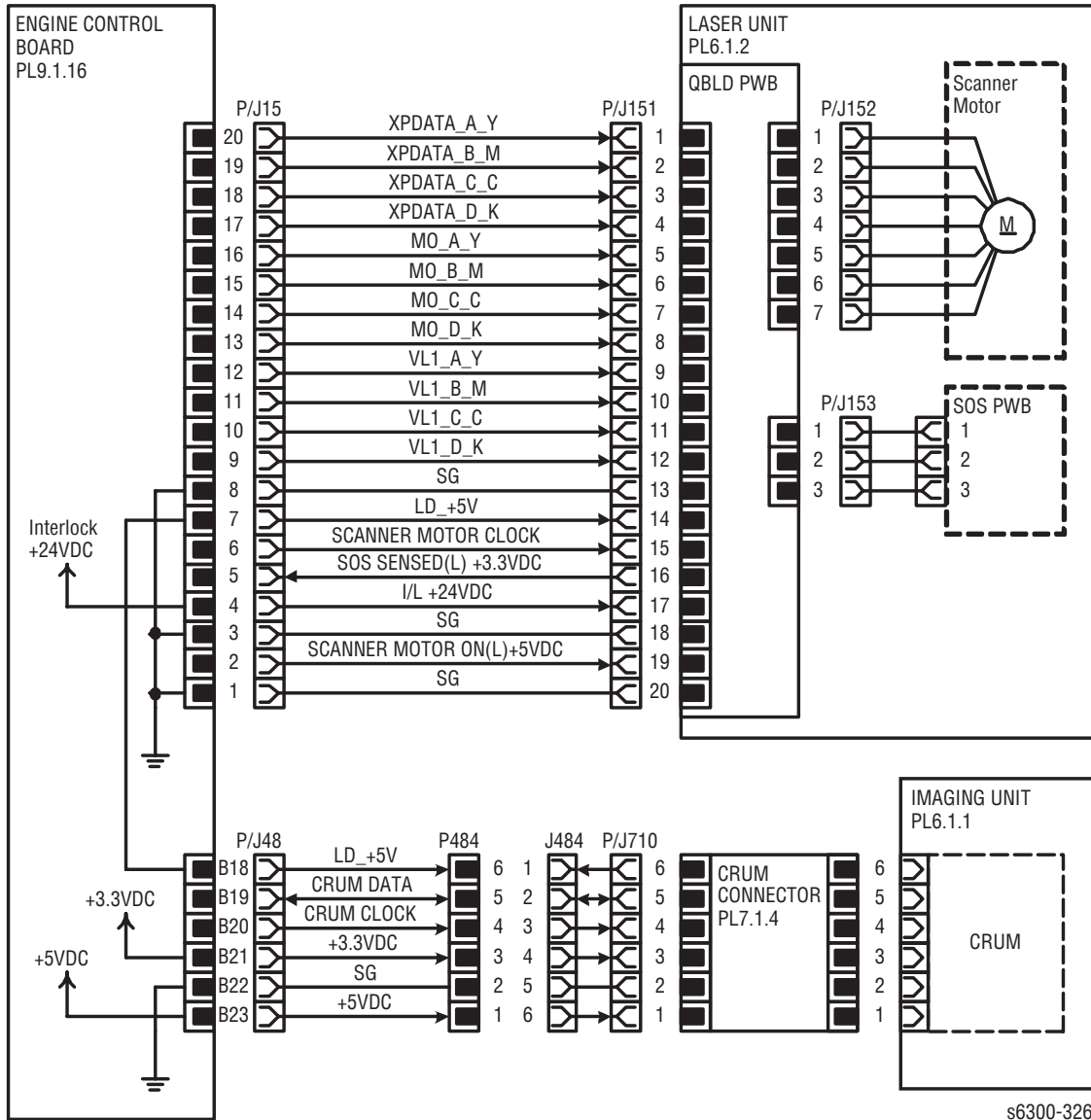

s6300-326

Xerographics (1/2)

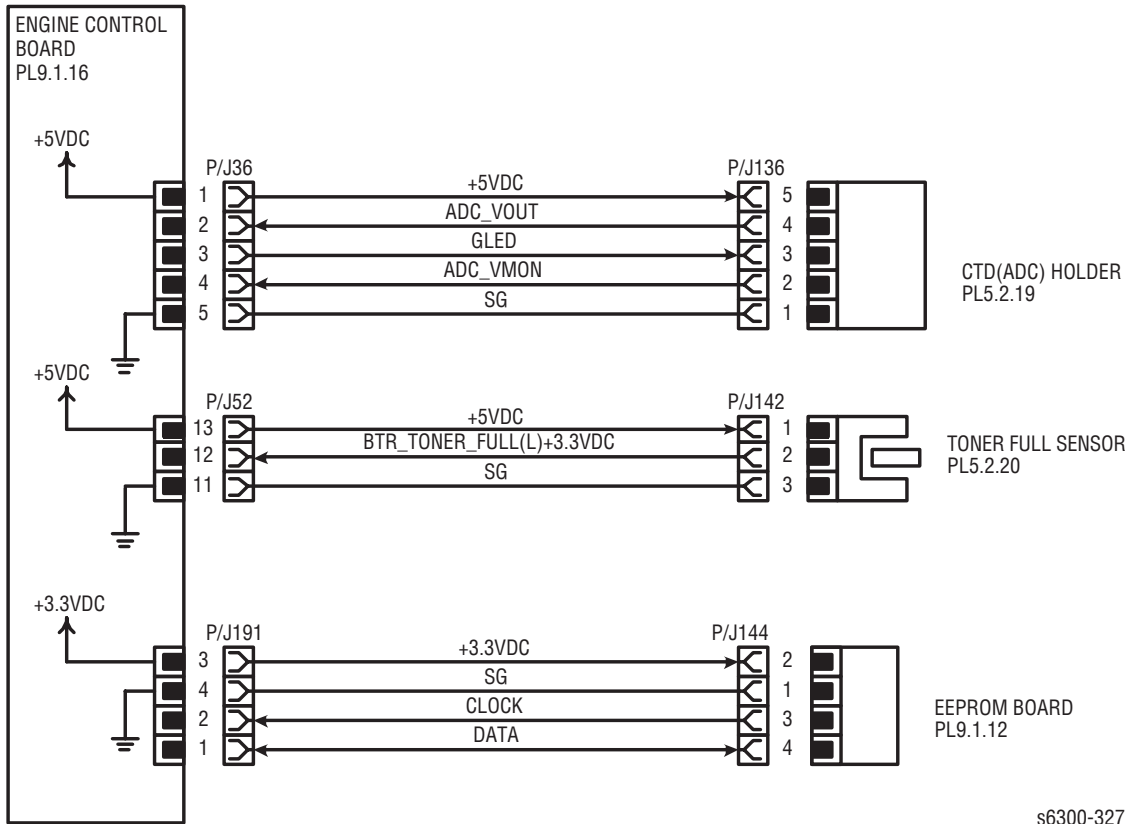

Xerographics (2/2)

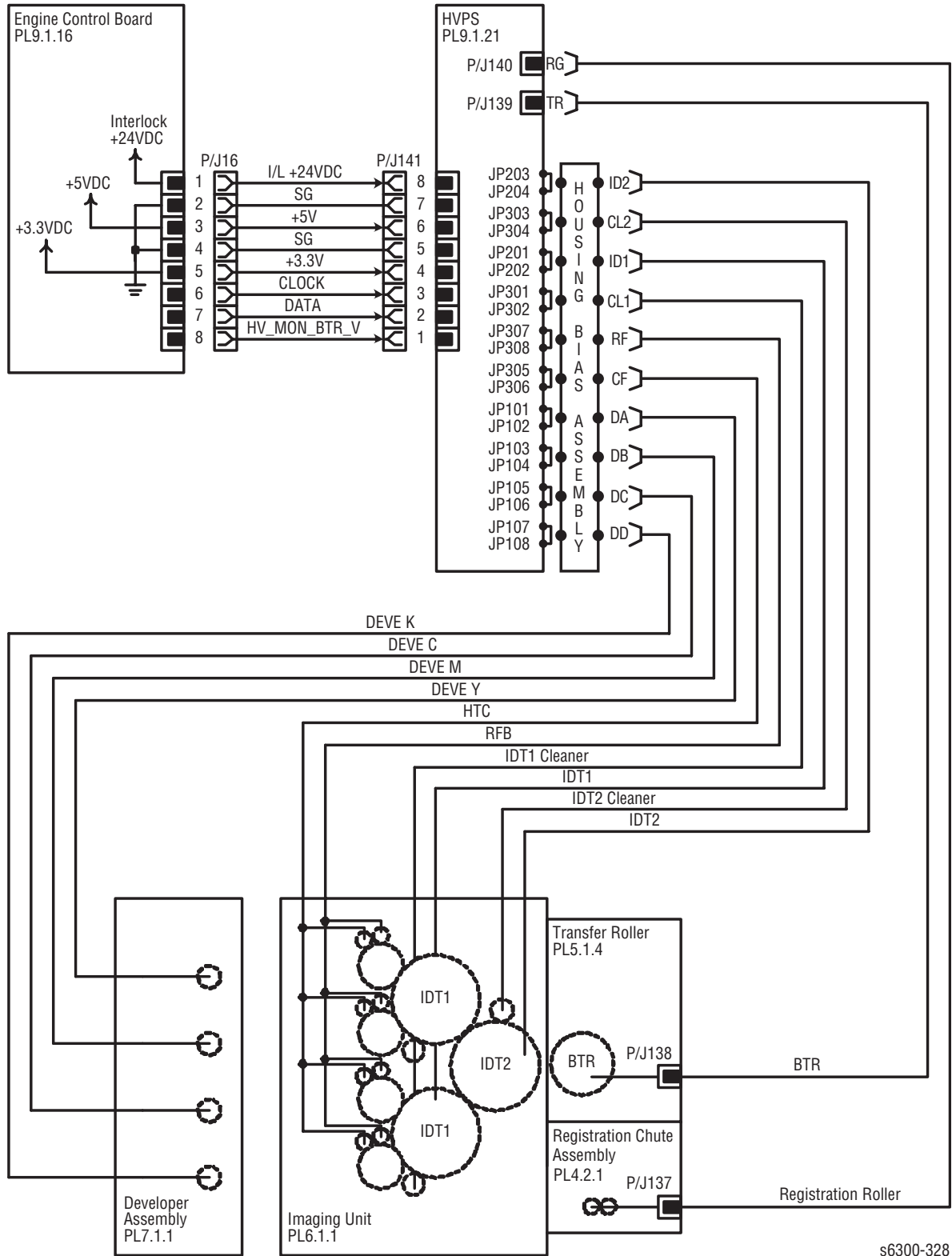

s6300-328

Paper Feed

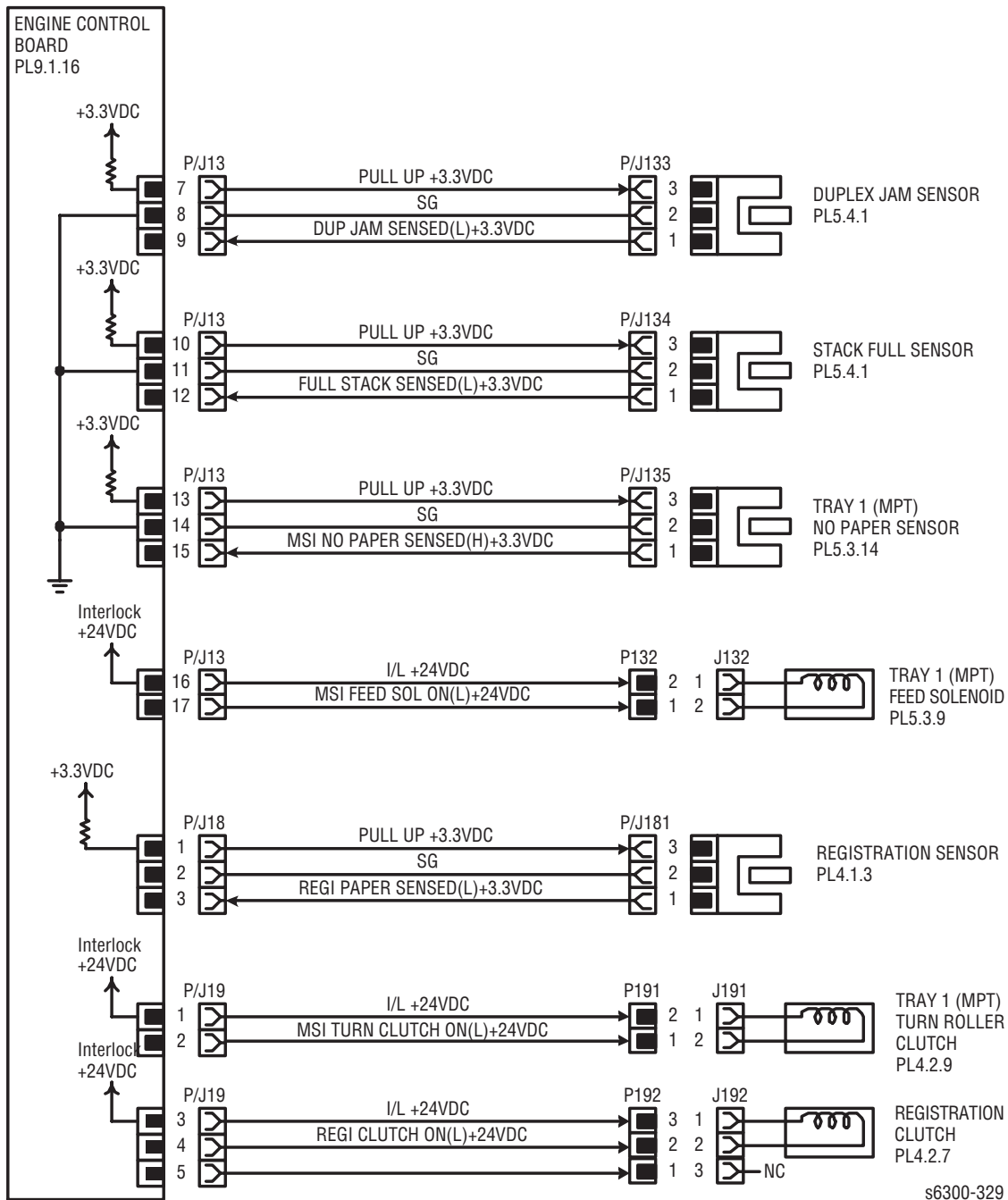
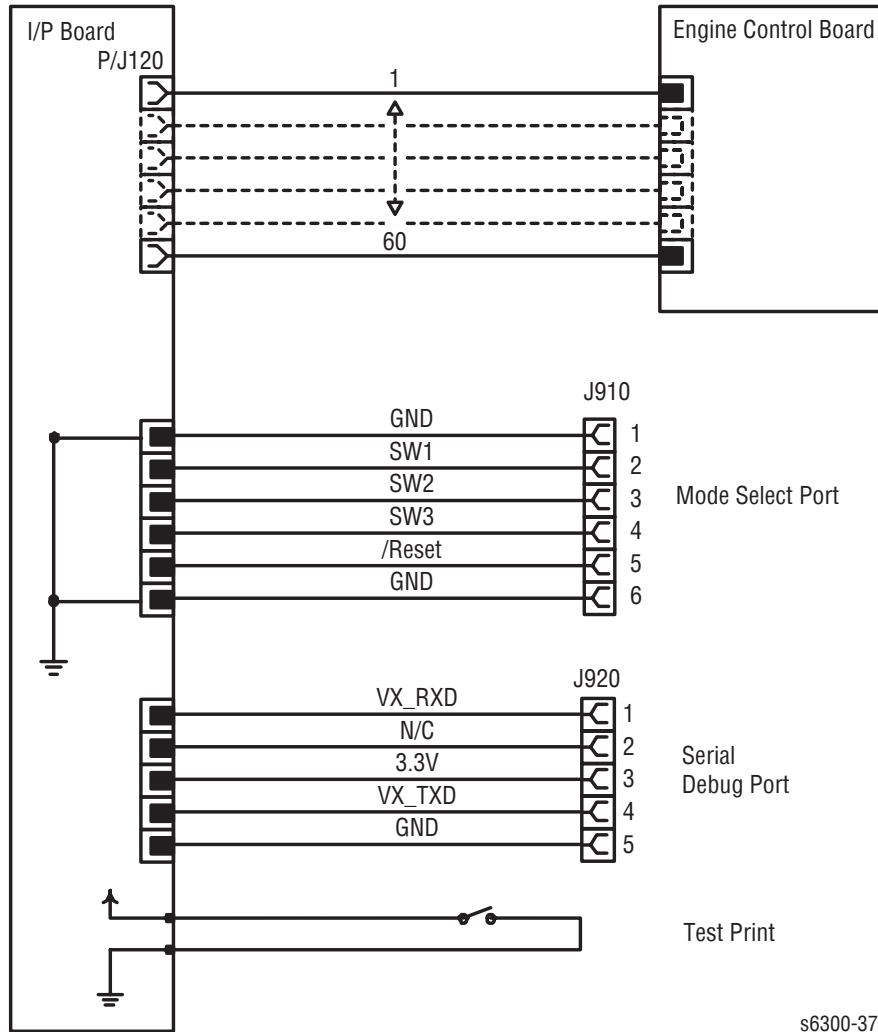
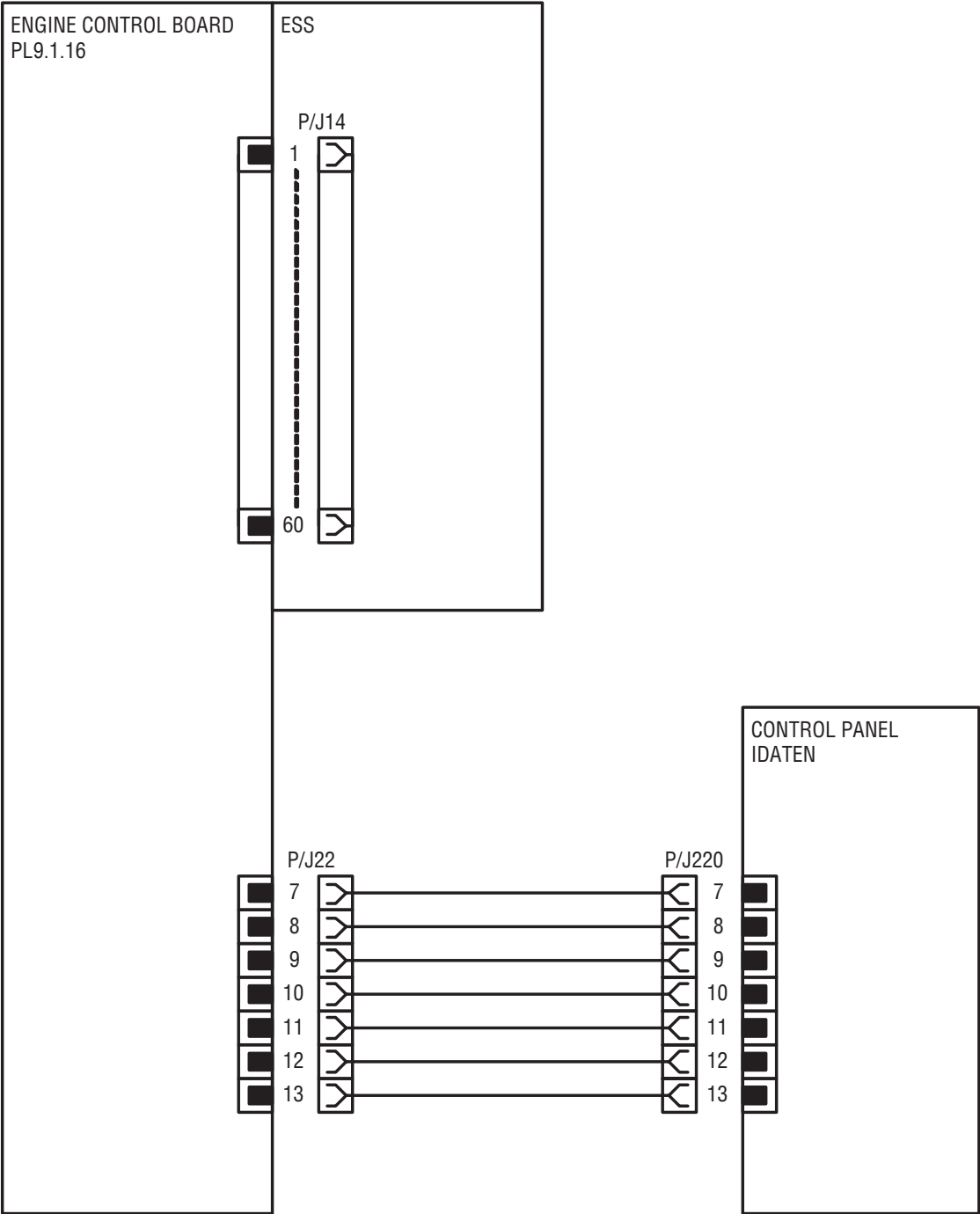

Image Processor Board



s6300-372

Control Panel



s6300-330

1100-Sheet Feeder Wiring Diagrams

1100-Sheet Feeder General Wiring

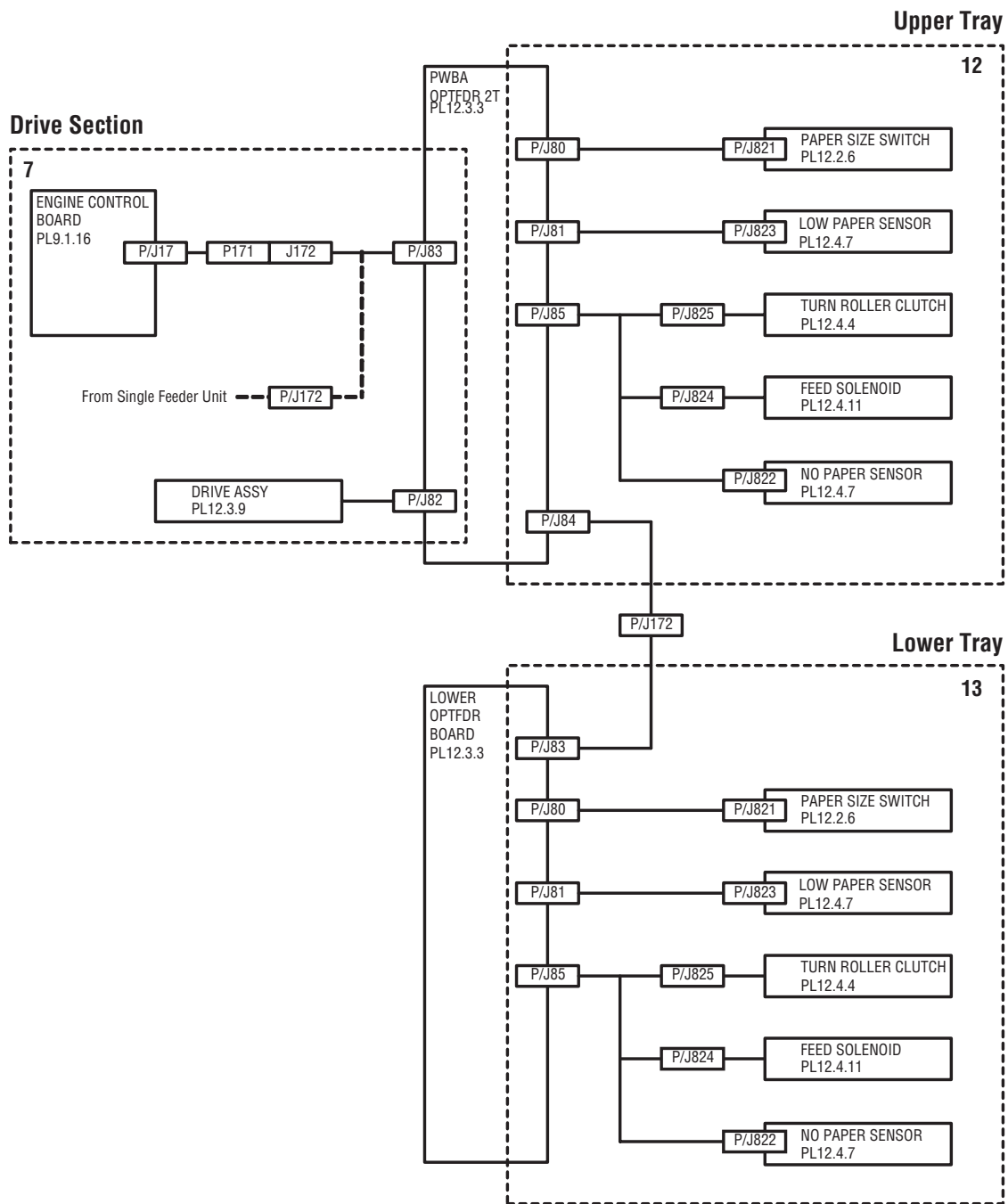

s6300-336

Drive

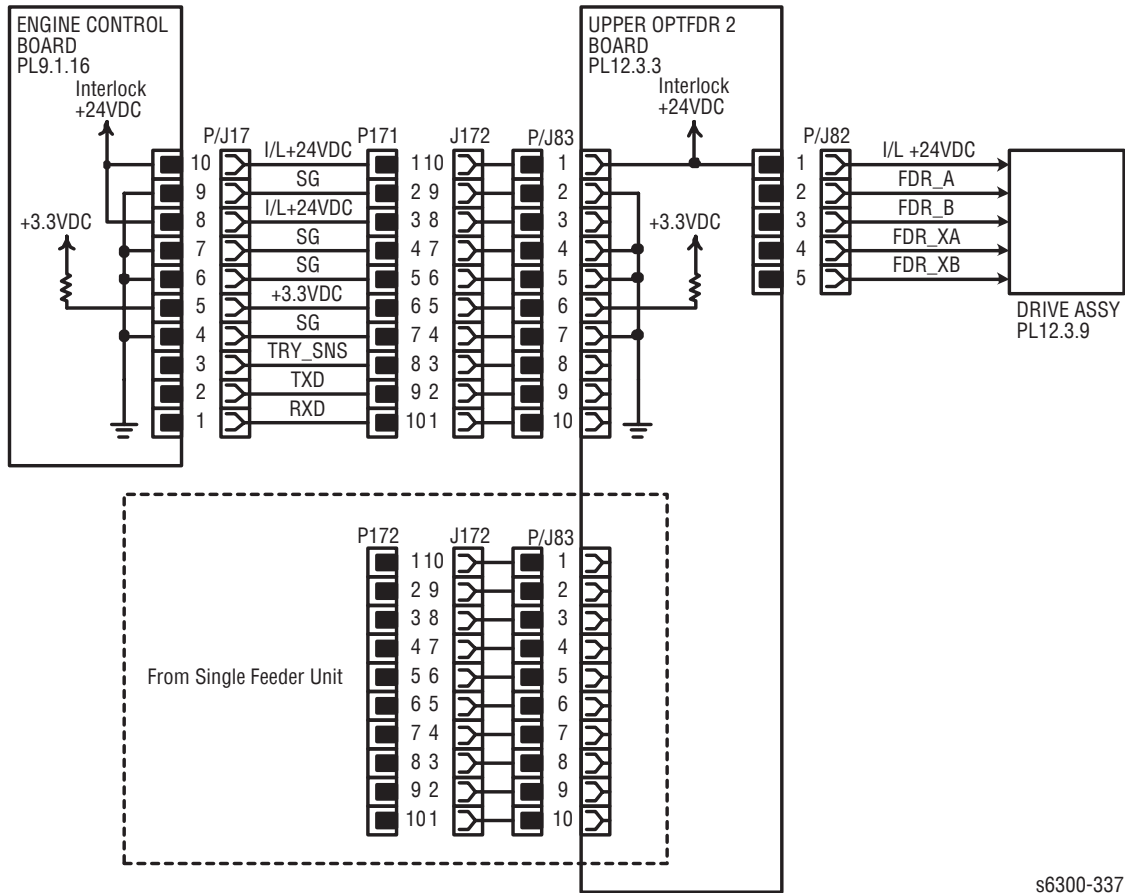

s6300-337

Upper Tray

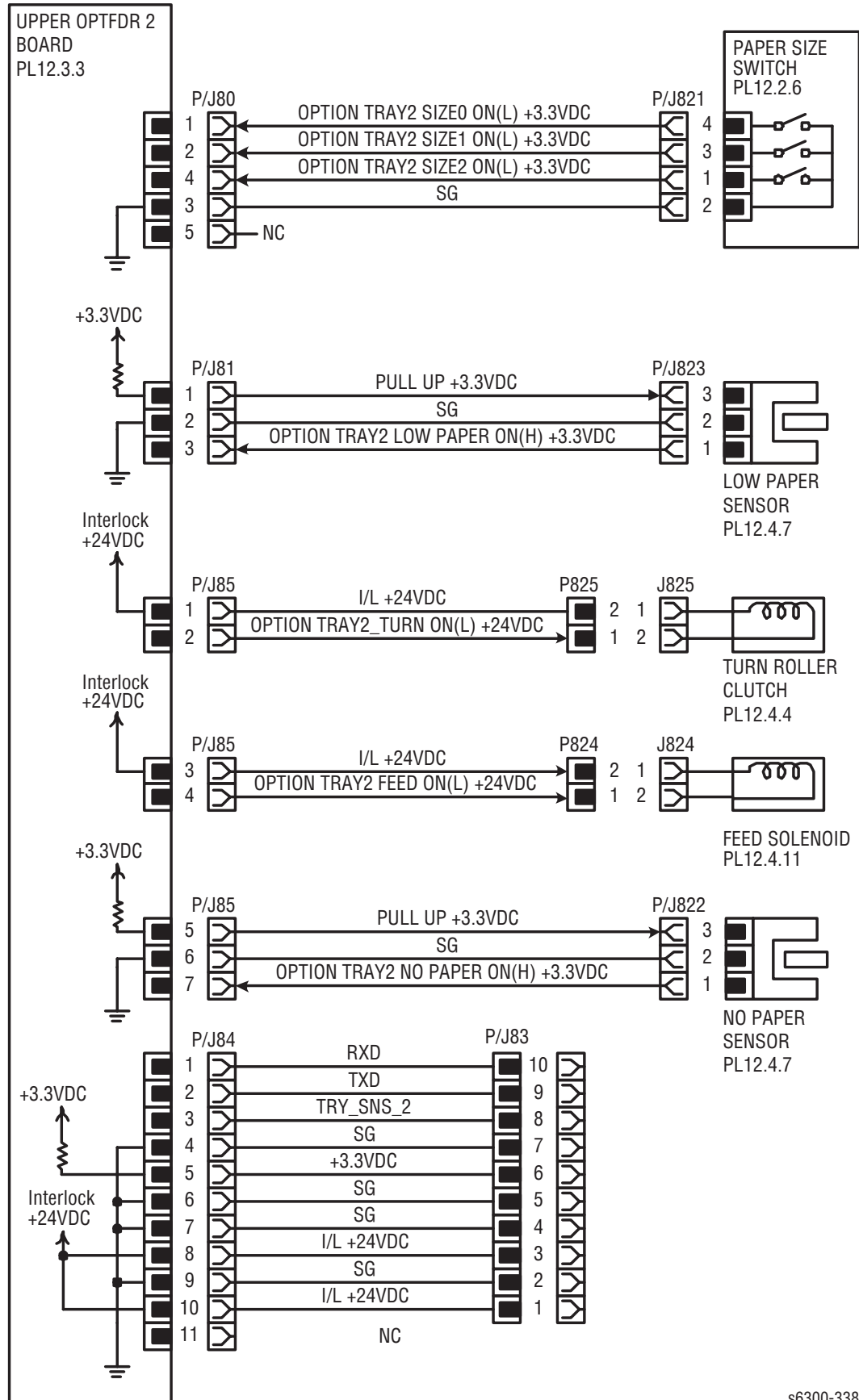

s6300-338

Lower Tray

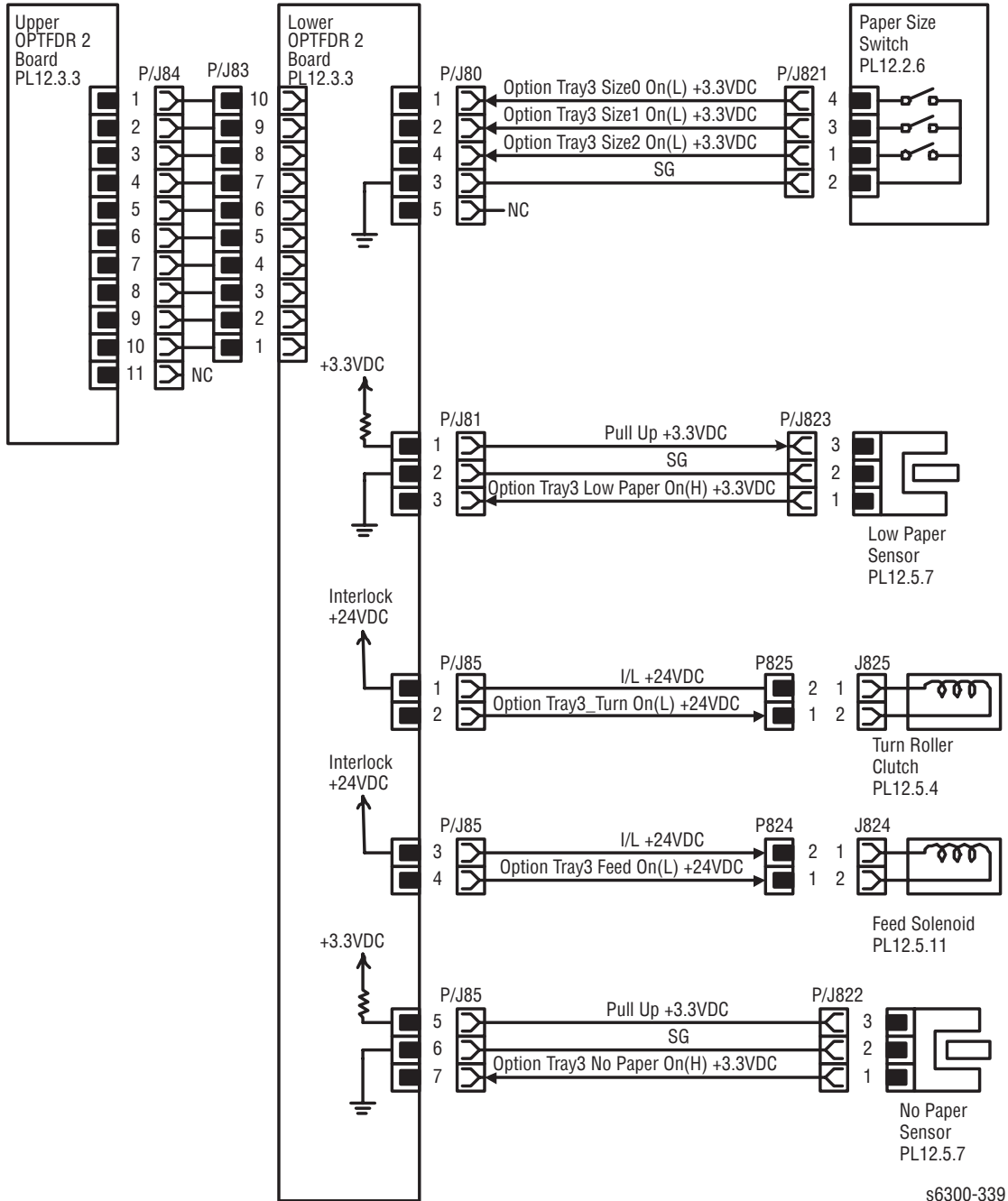

s6300-339

550-Sheet Feeder Wiring Diagrams

550-Sheet Feeder General Wiring

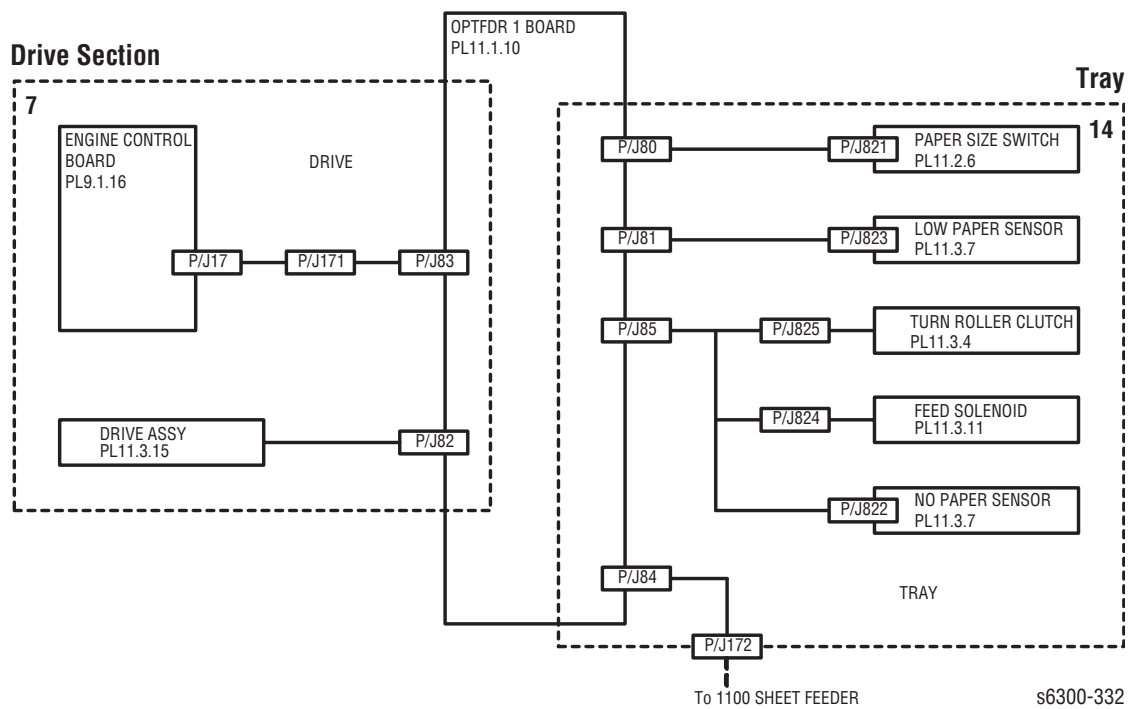

Drive

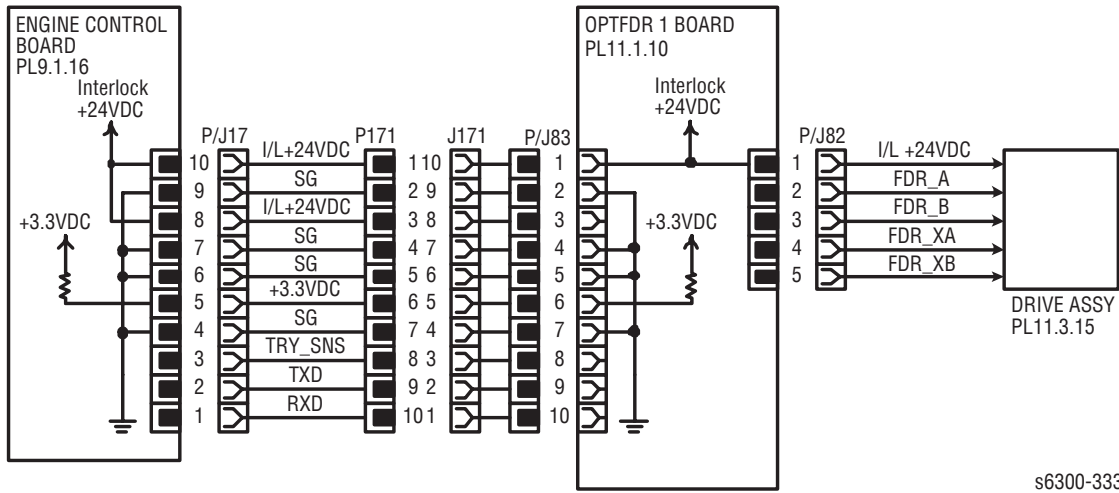

s6300-333

Tray

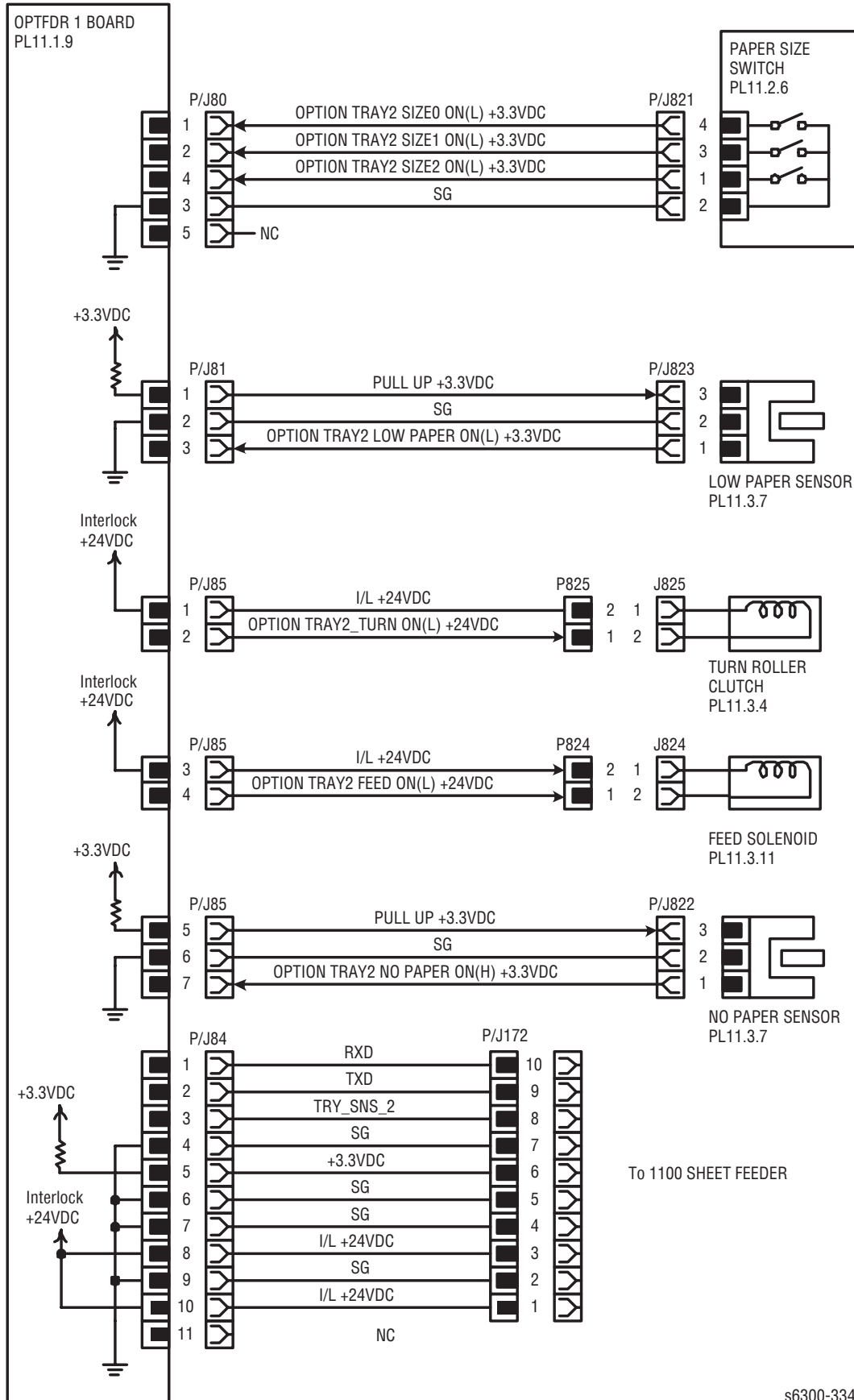

Reference

Contents...

- Phaser 6300/6350 Menu Map
- Printer Status Codes
- Service Diagnostics Menu Map
- Service Diagnostic Test Descriptions
- Preparing the Printer for Shipment

Appendix

A



Phaser 6300/6350 Menu Map

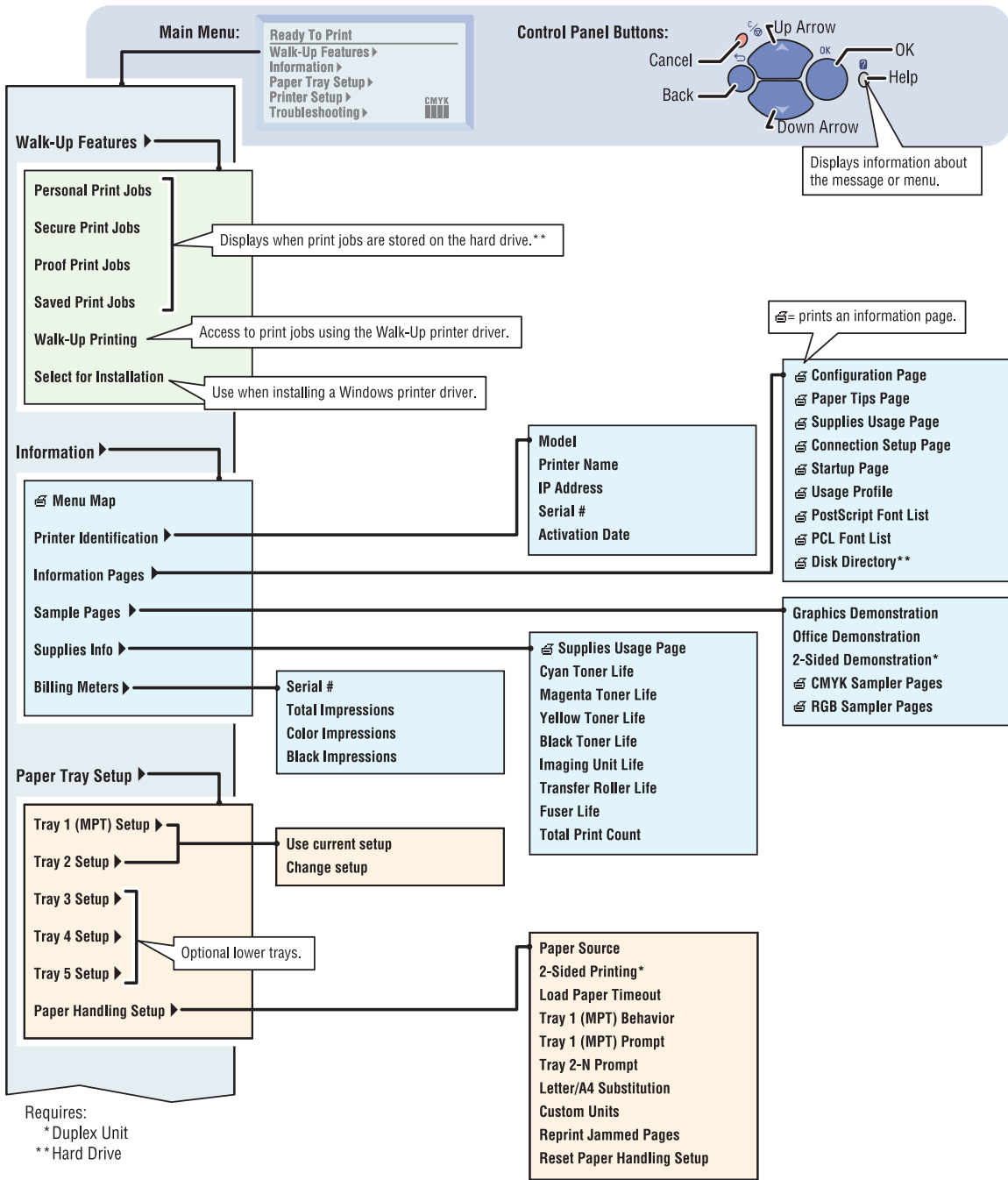

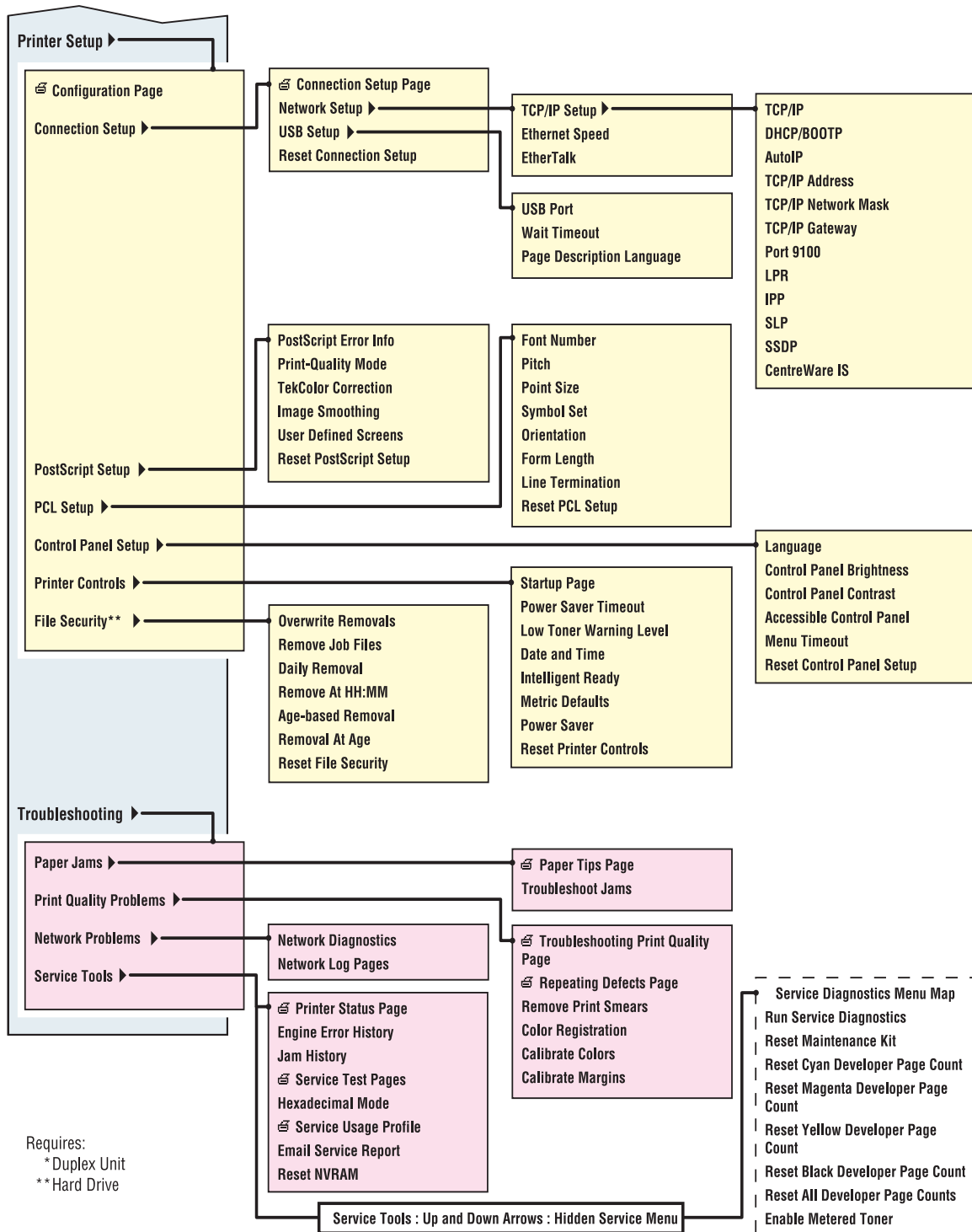

Printer Status Codes

Printer status codes that appear in the Service Usage Profile at line 237, on the printer Status page, and output by the Diagnostic Fault History utility are defined in the following table. Refer to the "Messages, Codes, and Procedures" on page 3-5 for additional information.

Printer Status Codes

| Code | Description |
|------|---|
| 7 | Laser Failure 7. Laser power failure. |
| 8 | Laser Failure 8. Laser Start of Scan error 1. |
| 9 | Laser Failure 9. Laser Start of Scan error 2. |
| 10 | Laser Failure 10. Laser warm-up error. |
| 11 | Laser Failure 11. General Laser Unit error. |
| 13 | Density Sensor Failure 13. CTD (ADC) Sensor failure. |
| 14 | Density Sensor Failure 14. CTD (ADC) Sensor Toner Density Control signal is over limit. |
| 15 | Density Sensor Failure 15. CTD (ADC) Sensor Toner Density Control signal is at limit. |
| 16 | Density Sensor Failure 16. General CTD (ADC) Sensor error. |
| 40 | Fuser Failure 40. Fuser exceeding temperature range. |
| 41 | Fuser Failure 41. Fuser below temperature range. |
| 42 | Fuser Failure 42. Fuser Temperature Sensor error. |
| 43 | Fuser Failure 43. Fuser did not reach warm-up temperature in time. |
| 44 | Fuser Failure 44. Fuser heater failure. |
| 45 | Fuser Failure 45. Fuser heater regulation failure. |
| 47 | Fuser Failure 47. General Fuser error. |
| 50 | Fuser Fan Failure. Fuser Fan rotation signal error. |
| 51 | Rear Fan Failure. Rear Fan rotation signal error. |
| 52 | Fan Failure. General Fan error. |
| 70 | Engine Firmware Failure 70. Fuser temperature firmware error. |
| 71 | Engine Firmware Failure 71. Cleaning count firmware error. |
| 72 | Engine Firmware Failure 72. NVRAM failure. |
| 73 | Engine Firmware Failure 73. NVRAM Checksum error. |
| 74 | Engine Firmware Failure 74. ASIC failure. |
| 76 | Fuser Firmware Failure. Fuser NVRAM failure. |
| 77 | Image Density Error. Density firmware failure. |

Printer Status Codes (Continued)

| Code | Description |
|------|--|
| 78 | Engine Firmware Failure 78. CRUM data firmware failure. |
| 79 | Engine Firmware Failure 79. Engine Control Board ROM error. |
| 80 | Hard Drive Failure. IDE Hard Disk failure. |
| 81 | Engine Communication Failure. Unable to properly communicate with the Engine Control Board. |
| 83 | Engine NVRAM Failure. Engine Control Board NVRAM error. |
| 86 | Cyan Toner Cartridge Failure. Cyan cartridge CRUM data error. |
| 87 | Magenta Toner Cartridge Failure. Magenta cartridge CRUM data error. |
| 88 | Yellow Toner Cartridge Failure. Yellow cartridge CRUM data error. |
| 89 | Black Toner Cartridge Failure. Black cartridge CRUM data error. |
| 90 | Replace Cyan Toner Cartridge. The Cyan Toner Cartridge CRUM indicates that the cartridge is not a Xerox product (CRUM ID error). |
| 91 | Replace Magenta Toner Cartridge. The Magenta Toner Cartridge CRUM indicates that the cartridge is not a Xerox product (CRUM ID error). |
| 92 | Replace Yellow Toner Cartridge. The Yellow Toner Cartridge CRUM indicates that the cartridge is not a Xerox product (CRUM ID error). |
| 93 | Replace Black Toner Cartridge. The Black Toner Cartridge CRUM indicates that the cartridge is not a Xerox product (CRUM ID error). |
| 94 | Non-Phaser 6300 Fuser. The Fuser CRUM indicates that the installed Fuser is not a 6300/6350 replacement part (Fuser CRUM ID error). |
| 95 | Non-Xerox Imaging Unit. The Imaging Unit CRUM indicates that the Imaging Unit is not a genuine Xerox replacement part. |
| 96 | Replace Non-Xerox Cyan Toner Cartridge. User selected to not to use a third-party Toner Cartridge when prompted. |
| 97 | Replace Non-Xerox Magenta Toner Cartridge. User selected to not to use a third-party Toner Cartridge when prompted. |
| 98 | Replace Non-Xerox Yellow Toner Cartridge. User selected to not to use a third-party Toner Cartridge when prompted. |
| 99 | Replace Non-Xerox Black Toner Cartridge. User selected to not to use a third-party Toner Cartridge when prompted. |
| 101 | Replace Maintenance Kit. A Developer Assembly has reached its End of Life count of approx. 300K. At 360K, the error becomes a hard stop. |
| 102 | Environment Sensor Failure. This indicates a Temperature/Humidity Sensor signal failure. |
| 103 | Fuser Motor Failure. This indicates a Fuser Motor rotation signal error. |
| 104 | Developer Motor Failure. This indicates a Developer Motor rotation signal error. |
| 105 | Main Motor Failure. This indicates a Main Drive Motor rotation signal error. |
| 106 | Motor Failure. General motor error. |

Printer Status Codes (Continued)

| Code | Description |
|------|---|
| 150 | Close Front Door. The Interlock Switch indicates that Door A or B is open. |
| 151 | Dusty Density Sensor. The CTD (ADC) Sensor does not reach reference voltage. |
| 152 | Jam at Fuser. The Fuser Exit Sensor indicates that paper remains in the Fuser. |
| 153 | Jam at Duplex. The Duplex Jam Sensor indicates that paper remains in the chute. |
| 154 | Jam at Registration Roller. The Registration Sensor indicates paper in the rollers. |
| 155 | Misfeed at Tray 1 (MPT). Paper from Tray 1 did not reach the Registration Sensor on time. |
| 156 | Misfeed at Tray 2. Paper from Tray 2 did not reach the Registration Sensor on time. |
| 157 | Misfeed at Tray 3. Paper from Tray 3 did not reach the Registration Sensor on time. |
| 158 | Misfeed at Tray 4. Paper from Tray 4 did not reach the Registration Sensor on time. |
| 159 | Misfeed at Tray 5. Paper from Tray 5 did not reach the Registration Sensor on time. |
| 160 | Insert Tray 2. The Tray 2 Paper Size Switch indicates Tray 2 is missing. |
| 161 | Insert Tray 3. The Tray 3 Paper Size Switch indicates Tray 3 is missing. |
| 162 | Insert Tray 4. The Tray 4 Paper Size Switch indicates Tray 4 is missing. |
| 163 | Insert Tray 5. The Tray 5 Paper Size Switch indicates Tray 5 is missing. |
| 164 | Unsupported Configuration. Indicates more than one 550-Sheet Feeder is installed. |
| 165 | Out of paper: Load Tray 1 (MPT) with [size] [type]. The print job requests paper from Tray 1, but the Tray 1 (MPT) No Paper Sensor indicates an empty tray. |
| 166 | Out of paper: Load Tray 2 with [size] [type]. The print job requests paper from Tray 2, but the Tray 2 No Paper Sensor indicates an empty tray. |
| 167 | Out of paper: Load Tray 3 with [size] [type]. The print job requests paper from Tray 3, but the Tray 3 No Paper Sensor indicates an empty tray. |
| 168 | Out of paper: Load Tray 4 with [size] [type]. The print job requests paper from Tray 4, but the Tray 4 No Paper Sensor indicates an empty tray. |
| 169 | Out of paper: Load Tray 5 with [size] [type]. The print job requests paper from Tray 5, but the Tray 5 No Paper Sensor indicates an empty tray. |
| 170 | Manual Feed [size] [type]. The print job requests a manual feed of [size] [type]. |
| 171 | Paper Not Available Load Tray 1 (MPT) with [size] [type]. The Paper Size Switch indicates that the paper loaded in Tray 1 (MPT) does not match the size specified by the print job. |
| 172 | Paper Not Available Load Tray 2 with [size] [type]. The Paper Size Switch indicates that the paper loaded in Tray 2 does not match the size specified by the print job. |
| 173 | Paper Not Available Load Tray 3 with [size] [type]. The Paper Size Switch indicates that the paper loaded in Tray 3 does not match the size specified by the print job. |
| 174 | Paper Not Available Load Tray 4 with [size] [type]. The Paper Size Switch indicates that the paper loaded in Tray 4 does not match the size specified by the print job. |
| 175 | Paper Not Available Load Tray 5 with [size] [type]. The Paper Size Switch indicates that the paper loaded in Tray 5 does not match the size specified by the print job. |

Printer Status Codes (Continued)

| Code | Description |
|------|---|
| 176 | Wrong paper size: Load Tray 1 (MPT) with [size] [type]. The Paper Size Switch indicates that the paper loaded in Tray 1 (MPT) does not match the size specified by the print job. |
| 177 | Wrong paper size: Load Tray 2 with [size] [type]. The Paper Size Switch indicates that the paper loaded in Tray 2 does not match the size specified by the print job. |
| 178 | Wrong paper size: Load Tray 3 with [size] [type]. The Paper Size Switch indicates that the paper loaded in Tray 3 does not match the size specified by the print job. |
| 179 | Wrong paper size: Load Tray 4 with [size] [type]. The Paper Size Switch indicates that the paper loaded in Tray 4 does not match the size specified by the print job. |
| 180 | Wrong paper size: Load Tray 5 with [size] [type]. The Paper Size Switch indicates that the paper loaded in Tray 5 does not match the size specified by the print job. |
| 181 | Wrong paper size: Load Tray 1 (MPT) with [size] [type]. The Paper Size Switch indicates that the paper loaded in Tray 1 (MPT) does not match the size specified by the print job. |
| 182 | Wrong paper size: Load Tray 2 with [size] [type]. The Paper Size Switch indicates that the paper loaded in Tray 2 does not match the size specified by the print job. |
| 183 | Wrong paper size: Load Tray 3 with [size] [type]. The Paper Size Switch indicates that the paper loaded in Tray 3 does not match the size specified by the print job. |
| 184 | Wrong paper size: Load Tray 4 with [size] [type]. The Paper Size Switch indicates that the paper loaded in Tray 4 does not match the size specified by the print job. |
| 185 | Wrong paper size: Load Tray 5 with [size] [type]. The Paper Size Switch indicates that the paper loaded in Tray 5 does not match the size specified by the print job. |
| 186 | Paper Not Available Load Tray 1 (MPT) with [size] [type]. The Paper Size Switch indicates that the paper loaded in Tray 1 (MPT) does not match the size specified by the print job. |
| 187 | Paper Not Available Load Tray 2 with [size] [type]. The Paper Size Switch indicates that the paper loaded in Tray 2 does not match the size specified by the print job. |
| 188 | Paper Not Available Load Tray 3 with [size] [type]. The Paper Size Switch indicates that the paper loaded in Tray 3 does not match the size specified by the print job. |
| 189 | Paper Not Available Load Tray 4 with [size] [type]. The Paper Size Switch indicates that the paper loaded in Tray 4 does not match the size specified by the print job. |
| 190 | Paper Not Available Load Tray 5 with [size] [type]. The Paper Size Switch indicates that the paper loaded in Tray 5 does not match the size specified by the print job. |
| 191 | Output Tray is Full Unload Paper. The Full Stack Sensor indicates a full Output Tray. |
| 192 | Replace Cyan Toner Cartridge. Cyan cartridge life counter is at end of life. |
| 193 | Replace Magenta Toner Cartridge. Magenta cartridge life counter is at end of life. |
| 194 | Replace Yellow Toner Cartridge. Yellow cartridge life counter is at end of life. |
| 195 | Replace Black Toner Cartridge. Black cartridge life counter is at end of life. |
| 196 | Replace Imaging Unit. Imaging Unit life counter is at end of life. |
| 197 | Replace Transfer Roller. The Toner Full Sensor indicates the waste toner reservoir is full. |
| 198 | Cyan Developer Empty. Cyan Developer Assembly life counter is at end of life. |

Printer Status Codes (Continued)

| Code | Description |
|------|--|
| 199 | Magenta Developer Empty. Magenta Developer Assembly life counter is at end of life. |
| 200 | Yellow Developer Empty. Yellow Developer Assembly life counter is at end of life. |
| 201 | Black Developer Empty. Black Developer Assembly life counter is at end of life. |
| 202 | Replace Cyan Toner Cartridge. Cyan cartridge life counter is at end of life. |
| 203 | Replace Magenta Toner Cartridge. Magenta cartridge life counter is at end of life. |
| 204 | Replace Yellow Toner Cartridge. Yellow cartridge life counter is at end of life. |
| 205 | Replace Black Toner Cartridge. Black cartridge life counter is at end of life. |
| 206 | Replace Transfer Roller. The Toner Full Sensor indicates the waste toner reservoir is full. |
| 207 | Replace Fuser. The Fuser life count is at end of life. |
| 208 | Install or Lock Cyan Toner Cartridge. The Toner Cartridge In Sensor indicates the Cyan cartridge is absent. |
| 209 | Install or Lock Magenta Toner Cartridge. The Toner Cartridge In Sensor indicates the Magenta cartridge is absent. |
| 210 | Install or Lock Yellow Toner Cartridge. The Toner Cartridge In Sensor indicates the Yellow cartridge is absent. |
| 211 | Install or Lock Black Toner Cartridge. The Toner Cartridge In Sensor indicates the Black cartridge is absent. |
| 212 | Install or Reseat Imaging Unit. The Imaging Unit CRUM does not detect the Imaging Unit. |
| 213 | Install or Reseat Transfer Roller. The CTD (ADC) Sensor does not detect the Transfer Roller. |
| 214 | Install or Reseat Fuser. Fuser CRUM not detected. |
| 215 | Remove Ribbon From Cyan Toner Cartridge. The No Toner Sensor indicates the Ribbon is present on the Cyan cartridge. |
| 216 | Remove Ribbon From Magenta Toner Cartridge. The No Toner Sensor indicates the Ribbon is present on the Magenta cartridge. |
| 217 | Remove Ribbon From Yellow Toner Cartridge. The No Toner Sensor indicates the Ribbon is present on the Yellow cartridge. |
| 218 | Remove Ribbon From Black Toner Cartridge. The No Toner Sensor indicates the Ribbon is present on the Black cartridge. |
| 219 | The Cyan Toner Cartridge is not a genuine Xerox product. The Toner Cartridge CRUM indicates the Cyan cartridge is not a Xerox product. |
| 220 | The Magenta Toner Cartridge is not a genuine Xerox product. The Toner Cartridge CRUM indicates the Magenta cartridge is not a Xerox product. |
| 221 | The Yellow Toner Cartridge is not a genuine Xerox product. The Toner Cartridge CRUM indicates the Yellow cartridge is not a Xerox product. |
| 222 | The Black Toner Cartridge is not a genuine Xerox product. The Toner Cartridge CRUM indicates the Black cartridge is not a Xerox product. |

Printer Status Codes (Continued)

| Code | Description |
|------|--|
| 223 | Metered Toner is not Enabled. Set metered (PagePack) PIN for metered operation. |
| 224 | Replace Cyan Toner Cartridge. The Toner Cartridge CRUM indicates that the Cyan Cartridge is a metered cartridge for use in metered (PagePack) printers, or is the wrong Phaser 63XX series configuration type. |
| 225 | Replace Magenta Toner Cartridge. The Toner Cartridge CRUM indicates that the Magenta Cartridge is a metered cartridge for use in metered (PagePack) printers, or is the wrong Phaser 63XX series configuration type. |
| 226 | Replace Yellow Toner Cartridge. The Toner Cartridge CRUM indicates that the Yellow Cartridge is a metered cartridge for use in metered (PagePack) printers, or is the wrong Phaser 63XX series configuration type. |
| 227 | Replace Black Toner Cartridge. The Toner Cartridge CRUM indicates that the Black Cartridge is a metered cartridge for use in metered (PagePack) printers, or is the wrong Phaser 63XX series configuration type. |
| 228 | Unknown Error. An error has been reported without specific interpretation by the software. |
| 229 | Replace Cyan Toner Cartridge. The Toner CRUM indicates that the cartridge is the wrong Phaser Series configuration type. |
| 230 | Replace Magenta Toner Cartridge. The Toner CRUM indicates that the cartridge is the wrong Phaser Series configuration type. |
| 231 | Replace Yellow Toner Cartridge. The Toner CRUM indicates that the cartridge is the wrong Phaser Series configuration type. |
| 232 | Replace Black Toner Cartridge. The Toner CRUM indicates that the cartridge is the wrong Phaser Series configuration type. |
| 233 | Replace Non-Phaser 6300/6350 Fuser. The Fuser CRUM indicates that the installed Fuser is not a 6300/6350 replacement part. |
| 234 | Replace Non-Phaser 6300/6350 Imaging Unit. The Imaging Unit CRUM indicates that the Imaging Unit is not a 6300/6350 replacement part. |

Service Diagnostics Menu Map

Phaser® 6300/ 6350 Service Diagnostic Menu Map

[Print Service Menu Map](#) Prints a service diagnostics menu map.

[General Status](#) Provides the following print engine status

Status.

Engine Board ROM Version:<Version>

Printer configuration

Ambient Temp/ Humidity

Fuser Temperature

Fault History

[Test Prints](#) Prints Test Prints stored in the MCU.

The prints are used by the service personnel to identify, repair, and validate the operability of the printer.

Blank Page Print

Standard Test Print

Custom Test Print

Current Custom Test Print Setup

Custom Test Print Parameters

[Motor/ Fan Tests](#) Tests the functionality of motors and fans by giving service personnel the ability to energize/ de-energize the motor and fans one at a time.

Main Motor

Duplex Motor

Fuser Motor

Developer Motor

HCF/ LTA Motors 1 & 2

Toner Motors (Y) (M) (C) (K)

Rear Fan

Fuser Fan

[Sensor/ Switch Tests](#) Tests the functionality of sensors and switches by giving service personnel the ability to input actuation and state changes of all sensors and switches.

Interlock Switch

Registration Sensor

Exit Sensor

Duplex Sensor

Full Stack Sensor

Toner Low Sensors (B) (C) (M) (Y)

Black Toner Cart Present Switch

Cyan Toner Cart Present Switch

Magenta Toner Cart Present Switch

Yellow Toner Cart Present Switch

Black Toner CRUM Sensor

Cyan Toner CRUM Sensor

Magenta Toner CRUM Sensor

Yellow Toner CRUM Sensor

Tray 2 Low Paper Sensor

Tray 3 Low Paper Sensor

Tray 4 Low Paper Sensor

Tray 5 Low Paper Sensor

Tray 1 (MPT) No Paper Sensor

Tray 2 No Paper Sensor

[Sensor/ Switch Tests - cont'd-](#)

Tray 3 No Paper Sensor

Tray 4 No Paper Sensor

Tray 5 No Paper Sensor

Transfer Roller Toner Full Sensor

Image Unit Installed/ Not Installed

Fuser Fan Rotation Sensor

Rear Fan Rotation Sensor

Motor Rotation Sensor(s) Main, Developer, Fuser

ADC (CTD) Sensor

Fuser NC Sensor

Fuser STS Sensor

Fuser NC Sensor Amplifier

Fuser Temp Compensation

[Clutch Tests](#) Tests the functionality of the clutches by giving the service personnel the ability to energize/ de-energize one clutch at a time.

Registration Clutch

Tray 1 (MPT) Turn Clutch

Tray 3 Turn Clutch

Tray 4 Turn Clutch

Tray 5 Turn Clutch

[Solenoid Tests](#) Tests the functionality of the solenoids by giving the service personnel the ability to energize/ de-energize one solenoid at a time.

Tray 1 (MPT) Feed Solenoid

Tray 2 Feed Solenoid

Tray 3 Feed Solenoid

Tray 4 Feed Solenoid

Tray 5 Feed Solenoid

[Maintenance](#) Cleans the IDT rollers within the Imaging Unit
Clean the Imaging Unit IDT Rollers

[NVRAM Access](#) This menu lets you read, set or reset the following values.

PostScript NVRAM Reset

MCU NVRAM Store/ Restore

Toner Install Dates

Toner CRUM Check

CRU Life Reset

CRU Life Read

[IP Controller diagnostics](#) Tests the basic functionality of the the IP Controller board.

RAM Read/ Write Test

[Exit](#) Exits service diagnostics and reboots the printer.

For Authorized Service Personnel Use Only

The Service Menu functions are to be used by Xerox service personnel and authorized service providers only. The printer can be damaged by the improper use of the built-in service tests.

Service Diagnostics Tests

Service Diagnostics Tests and Utilities

| Test | Control Panel Display and Test Definition | |
|---|--|--|
| Print Service Menu Map - Prints the Service Diagnostics menu then exits diagnostic mode. | | |
| General Status - Provides the following print engine status: | | |
| General Engine Status | No Status To Report -or one or more Printer Status Messages (page A-4) NOTE: This is current non-sequential status since entering diagnostics. If Ready is reached, Status is cleared. | No Status to Report = the printer is online and ready to print. Displays an engine status that will prevent printing. Status is displayed one line at a time. |
| Engine Board ROM Version | Engine FW: #.#.# or Unknown Engine NVRAM: #.#.# or Unknown Option Feeder: #.#.# or Unknown | Displays the engine/feeder firmware version installed, if known. |
| Printer Configuration | Memory: ###MB Hard Drive: Not Installed or Installed HCF/LTA: Installed or Not Installed | Displays current memory installed. Detects presence of Hard Drive. Detects presence of option feeder. Reboot printer to update option status. Do not lift engine from optional tray to test. |
| Ambient Temperature/ Humidity | Temperature: ## °C Temperature: ## °F Humidity: ## % | Displays the current Temperature and Humidity for the printer. |
| Fuser Temperature | Temperature: ## °C Temperature: ## °F | Displays the printer's current Fuser temperature. |
| Fault History | Fault History Display Fault History Master Clear List Cleared | Displays Fault occurrence since last power cycle. Cycle Power displays following Master Clear. |
| Test Prints - Prints test prints stored in the Engine Control Board. | | |
| Blank Page Print | Continuously prints blank pages until Cancel is pressed. | See "Test Prints" on page 5-4, "Adjustments" on page 6-3, and "Resetting NVRAM" on page 6-4, for specific test print information. |
| Standard Test Print | Continuously prints the Step pattern until Cancel is pressed. | |
| Custom Test Print | Prints the test pattern using the custom print parameters until Cancel is pressed. | |
| Current Custom Test Print Setup | Displays the print setup for the Current Test Print. | |
| Custom Test Print Parameters | Set Custom Test Print parameters. | |

Service Diagnostics Tests and Utilities (Continued)

| Test | Control Panel Display and Test Definition | |
|---|--|--|
| Set Default Print Parameters | Sets print parameters to default values: Color Mode: 4 Color, Print Mode: Simplex, Resolution: 600 dpi, Media Type: Plain Paper, Media Source: Tray 2, Media Coating: Normal, Media Size: Letter. Use 'Custom Test Print' to start printing. | |
| Motors/Fans Tests - Tests the motors and fans one at a time. | | |
| Main Motor | High Speed Normal Speed Half Speed One Third Speed High Speed Continuous Normal Speed Continuous Half Speed Continuous One Third Speed Continuous | Audible verification of motor function. The motor tests are pulsed or continuous. |
| Duplex Motor | Forward High Speed Forward Normal Speed Forward Half Speed Forward Slow Speed Forward Double High Speed Forward Double Speed Reverse High Speed Reverse Normal Speed Reverse Half Speed Reverse Slow Speed Reverse Double High Speed Reverse Double Speed Fwd Fast Speed Continuous Fwd Normal Speed Continuous Fwd Half Speed Continuous Fwd Slow Speed Continuous Fwd Double High Speed Continuous Fwd Double Speed Continuous Rev High Speed Continuous Rev Normal Speed Continuous Rev Half Speed Continuous Rev Slow Speed Continuous Rev Double High Speed Continuous Rev Double Speed Continuous | Audible verification of motor function. |
| Fuser Motor | High Speed Normal Speed Half Speed Slow Speed Normal Speed Continuous Normal Speed Continuous Half Speed Continuous Slow Speed Continuous | Audible verification of motor function. |

Service Diagnostics Tests and Utilities (Continued)

| Test | Control Panel Display and Test Definition | |
|--|--|--|
| Developer Motor | High Speed Normal Speed Half Speed Slow Speed Reverse High Speed Reverse Normal Speed Reverse Half Speed Reverse Slow Speed | Audible verification of motor function. CAUTION: Only run the developer motor test once per power cycle to avoid excessive amounts of toner being forced inside the developer. |
| HCF/LTA Motor 1 | High Speed Normal Speed Half Speed Slow Speed High Speed Continuous Normal Speed Continuous Half Speed Continuous Slow Speed Continuous Double High Speed Double Normal Speed Double Half Speed Double Slow Speed Double High Speed Continuous Double Normal Speed Continuous Double Half Speed Continuous Double Slow Speed Continuous | Audible verification of motor function. |
| HCF/LTA Motor 2 | High Speed Normal Speed Half Speed Slow Speed High Speed Continuous Normal Speed Continuous Half Speed Continuous Slow Speed Continuous Double High Speed Double Normal Speed Double Half Speed Double Slow Speed Double High Speed Continuous Double Normal Speed Continuous Double Half Speed Continuous Double Slow Speed Continuous | Audible verification of motor function. |
| Toner Motor Yellow Toner Motor Magenta Toner Motor Cyan Toner Motor Black | Normal Speed | Audible verification of motor functionality. CAUTION: Run the test just long enough to verify operation (<5 sec.) except when priming Auger Tubes. |

Service Diagnostics Tests and Utilities (Continued)

| Test | Control Panel Display and Test Definition | |
|---|--|--|
| Rear Fan | High Speed Low Speed High Speed Continuous Low Speed Continuous | Audible verification of motor function. Check for airflow. |
| Fuser Fan | High Speed Low Speed High Speed Continuous Low Speed Continuous | Audible verification of motor functionality. Check for airflow. |
| Sensor/Switch Tests - Tests the functionality of the sensors and switches. | | |
| Interlock Switch | Sensor is On Sensor is Off | Door A or B is open Door A or B is closed |
| Registration Sensor | Sensor is Off Sensor is On | This test continuously cycles paper. The sensor state changes as paper passes the sensor. NOTE: This test can also be used as a paper path transport test when troubleshooting Jam conditions. |
| Exit Sensor | Sensor is Off Sensor is On | Move the Exit Actuator (PL5.1.2) to toggle the sensor state. |
| Duplex Sensor | Sensor is Off Sensor is On | Move the Duplex Jam Actuator (PL5.4.13) to toggle the sensor. |
| Full Stack Sensor | Sensor is Off Sensor is On | Move the Full Stack Actuator (PL5.4.2) to toggle the sensor. |
| [Y][M][C][K] Toner Low | Toner is Low Toner is NOT Low | Displays current state of the sensor. |
| [Y][M][C][K] Toner Cartridge Present | Sensor is Off Sensor is On | Move the Toner Cartridge In switch (PL7.2.7) to change the sensor. Toner Cartridge is LOCKED. Toner Cartridge is UNLOCKED. |
| [Y][M][C][K] CRUM Sensor | Sensor is Off Sensor is On | Move the Toner Cartridge In switch (PL7.2.7) to change the sensor. Toner Cartridge is LOCKED. Toner Cartridge is UNLOCKED. |
| Tray [2] [3] [4] [5] Low Paper Sensor | Size: XXXX Paper is Not Low Paper is Low | Move the Tray Rear Guide or manually toggle the Paper Size Switch Actuators to the desired paper size and verify the sensor output. Fill tray with paper to the fill line. Insert one sheet of paper in tray to change the sensor. |

Service Diagnostics Tests and Utilities (Continued)

| Test | Control Panel Display and Test Definition | |
|--------------------------------------|---|--|
| Tray 1 (MPT) No Paper Sensor | Paper is Not Present Paper is Present | Move the Tray 1 No Paper Actuator (PL5.3.15) to change sensor state. |
| Tray [2] [3] [4] [5] No Paper Sensor | Paper is Not Present Paper is Present | Insert Tray [2] [3] [4] [5] with an adequate amount of paper. Toggle the No Paper Actuator. |
| Transfer Roller Toner Full Sensor | Toner Waste [Not] Full | Block the Toner Full Sensor (PL5.2.20) to change the sensor state. |
| Image Unit Not Installed Sensor | Image Unit is [Not] Present | Open Door C to change the state of the Switch. |
| Fuser Fan Rotation Sensor | Fuser Fan Rotation Sensor is: OK Failure | Status only |
| Rear Fan Rotation Sensor | Rear Fan Rotation Sensor is: OK Failure | Status only |
| CTD (ADC) Sensor | Dark Value: # Light Value: ### Sensor OK | Status only Remove the Transfer Roller to observe change of state. |
| Fuser NC Sensor | <Fuser NC Sensor> Fuser (Not) Ready Sensor (Failure) is OK | Remove Fuser to change sensor state. |
| Fuser STS Sensor | <Fuser STS Sensor> Fuser (Not) Ready Sensor (Failure) is OK | Remove Fuser to change sensor state. |
| Fuser NC Sensor Amplifier | <Fuser NC Sensor Amplifier> Fuser (Not) Ready Temperature Amplifier (Failure) is OK | Remove Fuser to change sensor state. |
| Fuser Temp Compensation | <Fuser Temp Compensation> Fuser (Not) Ready Compensation (Failure) is OK | Remove Fuser to change sensor state. |
| Main Motor Rotation Sensor | Main Motor Rotation Sensor is: OK Failure | Status only |
| Developer Motor Rotation Sensor | Developer Motor Rotation Sensor is: OK Failure | Status only |
| Fuser Motor Rotation Sensor | Fuser Motor Rotation Sensor is: OK Failure | Status only |

Service Diagnostics Tests and Utilities (Continued)

| Test | Control Panel Display and Test Definition | |
|---|--|---|
| Clutch Tests - Tests the functionality of the clutches. | | |
| Registration Clutch Tray 1 (MPT) Turn Clutch (PL4.2.9) Tray 3 Turn Clutch Tray 4 Turn Clutch Tray 5 Turn Clutch | Clutch is On Clutch is Off | Audible verification of Clutch functionality. You should hear a continuous clicking until the test is ended by pressing Cancel. |
| Solenoid Tests - Tests the functionality of the solenoids. | | |
| Tray [1 (MPT)][2][3] [4][5] Feed Solenoid | Solenoid is On Solenoid is Off | Audible verification of the Solenoid function. |
| Maintenance - Cleans the Intermediate Transfer Unit within the Imaging Unit. | | |
| Clean Imaging Unit IDT 1 Clean Imaging Unit IDT 2 | Printing..... | Printing displays during the IDT cleaning cycle. The test continuously cycles paper until Cancel is pressed. |
| NVRAM Access - This menu lets you read, set or reset the following values: | | |
| PostScript NVRAM Reset | Resetting PostScript NVRAM... Are you sure? Yes / NO | Restores the printer's setup values to their factory defaults. |
| MCU NVRAM Store/Restore | Save Engine NVRAM Restore Engine NVRAM | Saves printer installation date, printer page count, imaging unit life count, transfer roller life count to Image Processor Board. Restores previously saved data to the Engine Control Board. |
| Toner Install Dates | Black Toner Install Date Cyan Toner Install Date Magenta Toner Install Date Yellow Toner Install Date | Allows toner cartridge install dates to be viewed, or changed. |
| Toner CRUM Check | (<Color> Not) Genuine Xerox Toner | Verifies that genuine Xerox toner is installed in the printer. |
| CRU Life Reset | Resets life count of selected item. Confirmed Reset or Unconfirmed Reset Transfer Roller Life Reset value: 0 Units: Pages Black Developer (K) Life Reset value: 0 Units: Revolutions Cyan Developer (C) Life Reset value: 0 Units: Revolutions Magenta Developer (M) Life Reset value: 0 Units: Revolutions Yellow Developer (Y) Life Reset value: 0 Units: Revolutions | Sets Transfer Roller life to unused and resets the installation date to the current date indicated by the printer. NOTE: Toner CRUM life counts cannot be modified. Resets component life count. |

Service Diagnostics Tests and Utilities (Continued)

| Test | Control Panel Display and Test Definition | |
|--|---|--|
| CRU Life Read | Black Toner (K) Life Range: 0-9001 Units: Auger turns Cyan Toner (C) Life Range: 0-9001 Units: Auger turns Magenta Toner (M) Life Range: 0-9001 Units: Auger turns Yellow Toner (Y) Life Range: 0-9001 Units: Auger turns Transfer Roller Life Range: 0-35100 Units: Pages Read Printer Page Count Imaging Unit Count 1:Range: 0-38500 Units: Page Count 2:Range: 0-257000 Units: Rotations Count 3:Range: 0-144189 Units: Total Dispense Time Count 4:Range: 0-560 Units: Toner bottle exchange Count 5:Range: 0-8492 Units: Total Dispense Time relative to Count 4. Fuser Life Range value: 0-100000 Units: pages Black Developer (K) Life Range: 0-1608601 Units: Rotations Cyan Developer (C) Life Range: 0-1608601 Units: Rotations Magenta Developer (M) Life Range: 0-1608601 Units: Rotations Black Developer (K) Life Range: 0-1608601 Units: Rotations | Accesses the various life counts stored in NVRAM. |
| IP Controller Diagnostics - Tests the basic functionality of the Image Processor Board. | | |
| RAM Read/Write Test | Executing..... Passed | Does an extended memory test on the Image Processor Board. NOTE: Cycle power to the printer after executing this test. |
| Exit - Exits Service Diagnostics and reboots the printer. | | |

Mode Select Port

The Mode Select Port (J910), accessible from the Rear Panel, is a 6-pin port used to place the printer in one of two operational modes or to reset the Image Processor Board. To access these modes, turn off the power and connect a jumper between the pin or pins indicated in the following table and either pin1 or 6. When power is restored, the printer boots in the selected mode. The Mode Select Port pins are arranged in numeric order with Pin 1 nearest the power cord connection. Pins 1 and 6 are tied to a common ground with the Rear Panel.

Caution

To reset the Image Processor Board, momentarily ground pin 5, and then immediately re-open the connection. Grounding pin 5 for more than a few seconds could damage the processor.

Mode Select Port Settings

| Mode | 1 | 2 | 3 | 4 | 5 | 6 |
|---------------|-----|---|-----|-----|-----|-----|
| Printer Reset | GND | | | | GND | GND |
| Customer | GND | | | | | GND |
| Service | GND | | GND | GND | | GND |

- Reset is a hardware reset of the Image Processor Board.
- Customer Mode is the normal mode for printing. The Serial Debug Port is receiving PostScript back channel information.
- Service Mode inhibits printing of the Startup page and causes POST to treat all errors as Hard Faults. See "Power On Self Test (POST)" on page 4-3. Service Mode also switches the Serial Debug Port from PostScript back channel information to the printer's operating system console.

Obtaining Serial Back Channel Traces

In rare cases the printer may exhibit unusual behavior that is difficult to troubleshoot. In such cases, if feasible, it can be useful to obtain a back channel trace from the printer's Serial Debug Port. The back channel trace, lists step-by-step what the printer is doing up to the point that an error occurs. The trace may offer clues to help troubleshoot the problem. Alternately, you can email the trace to your RSS for his interpretation. You will need the following:

- Computer with a serial port
- Serial Cable, part number 012-1535-00
- Level Adaptor, part number 012-1543-00

To obtain a trace:

1. Connect the Serial Cable and Level Adaptor, then connect the Serial Cable to your PC. Serial port settings are COM1, 19.2 kbaud, 8 bits, no parity, 1 stop bit, and hardware control.
2. Turn off the printer.
3. Connect the Level Adaptor with adapter's THIS SIDE UP label facing upwards to the Serial Debug Port located on the printer's Rear Panel.
4. Start up a terminal program such as in Window's HyperTerminal (usually located in **Programs -- > Accessories --> Communications --> HyperTerminal**). Verify the serial port settings are correct, usually COM1:.
5. Set the printer to Service Mode by grounding the appropriate Mode Select Port pins (3 and 4).

Note

Service Mode inhibits automatic Startup page printing. Also, the Mode Select Port jumpers must remain in place to display the printer's operating system console.

6. Turn on the printer.

The trace should appear in the terminal window. Examine the trace to troubleshoot the problem. Save the trace as a file, if necessary.

Preparing the Printer for Shipment

Use either the original packing materials or the Repackaging Kit (065-0637-00) to package the printer for shipment. The Repackaging Kit includes detailed instructions to prepare the printer for shipment. If the original packaging is available, follow these instructions:

Caution

Do not remove the Toner Cartridges from the printer. Make sure each cartridge is securely locked in its holder before sealing the box. Failure to secure the Toner Cartridges in their holders for transport can result in irreversible damage to the printer.

1. Remove the Transfer Roller and place in sealed bag.
2. Remove the Imaging Unit and place in sealed, light-restrictive bag.
3. Install the orange Developer Assembly Shipping Restraint, part number 116-2043-00.
4. Secure the printer in the box using the original foam and cardboard inserts.
5. Securely seal and properly label the printer for shipment.

Index

Numerics

- 1100-Sheet Feeder, 1-9
 - Circuit Board HCF, 2-52
 - connections, 10-10
 - part number, 9-51
 - components, 2-50
 - dimensions, 1-13
 - docking, 8-110
 - Drive Motor, 2-52
 - connector location, 10-10
 - drive train, 2-53
 - part number, 9-51
 - removal, 8-121
 - wiring, 10-30
 - gearing, 2-54
 - Paper Pick Assemblies, 2-51
 - Paper Pick Assembly T1
 - part number, 9-53
 - removal, 8-122
 - Paper Pick Assembly T2
 - part number, 9-55
 - removal, 8-125
 - part number, 9-59
 - tray designations, 2-7
 - wiring diagram, 10-29
- 550-Sheet Feeder, 1-9
 - Circuit Board LTA, 2-57
 - connections, 10-12
 - components, 2-55
 - dimensions, 1-13
 - docking, 8-134
 - Drive Motor, 2-57
 - connector location, 10-12
 - drive train, 2-58
 - removal, 8-146
 - wiring, 10-34
 - gearing, 2-59
 - Paper Pick Assembly, 2-56
 - part number, 9-43
 - removal, 8-141

- part number, 9-59
- tray designation, 2-7
- unsupported configuration, 2-7
- wiring diagram, 10-33

A

- abbreviations, 3-5
- AC power, 2-49
 - consumption, 1-12
 - input specifications, 1-12
 - LVPS part number, 9-35
 - power cord, 9-35
 - Power Switch, 2-49
 - troubleshooting, 4-14
 - wiring, 10-17
- Actuator Kit, 9-62
- addressability, 1-14
- adjustments, 6-3
 - color balance, 6-2
 - color intensity, 6-2
 - color registration, 6-3
 - image area, 6-2
 - margins, 6-2
- Agitator, 2-46
- Auger Tube, 2-47
 - connecting, 8-79
 - precautions, 2-45
- automatic mode, 2-6

B

- back channel trace, A-19
- belt, Fuser, 2-38
- blank prints, 5-14
- boot
 - boot sequence, 4-2
 - command shortcuts, 1-6
- Boot Loader, 4-5
- button functions, 1-6

C

calibration

- calibrate colors page, 6-2
- color, 6-2
- margins, 6-2

Chute Assembly In, 2-33

- part number, 9-21
- removal, 8-58

Chute Assembly Out, 2-34

- duplex jam error, 3-6
- Gear Kit, 9-58
- part number, 9-23
- removal, 8-61

Circuit Board HCF, 2-52

- part number, 9-51
- removal, 8-120

Circuit Board LTA, 2-57

- removal, 8-138

cleaning cycle, 2-4

- frequency, 1-15

cleaning procedures, 7-2

- Developer Assemblies, 7-3
- Imaging Unit, 7-3
- laser windows, 7-4

cleaning utility, A-16

clearances, minimum, 1-13

Clutch tests, A-16

codes

- error, 3-6
- status, A-4

color

- balance, 6-2
- calibration, 6-2
- density, 5-7
- intensity, 6-2
- registration verification, 5-7
- restore default settings, 6-4

color registration, 2-12

Configuration Card, 1-8

- configuration card missing, 3-7
- failure, 3-64
- invalid configuration card, 3-7
- location, 1-7
- part number, 9-35
- upgrades, 9-59

Configuration page

- Hard Drive usage, 1-8
- memory statistics, 1-8
- metered operation, 1-4

connector

- designators, 10-2
- locations, 10-5
- representation, 3-9

consumable, 1-11

- errors, 3-6
- life counts, 1-11

Control Panel, 1-6

- buttons, 1-6
- command shortcuts, 1-6
- connector location, 10-5
- error log format, 3-3
- error messages, 3-6
- harness assembly, 9-23
- LED, 1-6
- part number, 9-5
- POST testing, 4-3
- removal, 8-11
- reset defaults, 6-6
- troubleshooting, 4-11
- wiring, 10-28

counters

- Developer Assembly life reset, 6-7
- Fuser life, 6-9
- Imaging Unit life, 6-9
- life counts, 1-11
- Long-Life Maintenance Kit, 6-7
- reset, A-16
- status page, 3-3
- storage, 1-8
- Toner Cartridge life, 6-9
- total page count, 6-9
- Transfer Roller life, 2-13

CPU interrupts error, 4-5

crossover cable, 4-24

CRUM, 3-5

CRUM Connector

- location, 2-21
- part number, 9-29
- removal, 8-80
- wiring, 10-23

- CRUM Reader, 2-46
 - connector location, 10-5
 - location, 2-45
 - part number, 9-31
 - removal, 8-83
 - testing, A-14
 - wiring, 10-20
- CTD (ADC) Sensor, 2-11
 - connector location, 10-6
 - dusty density sensor error, 3-6
 - dusty density sensor warning, 3-8
 - failure error, 3-7
 - image density error, 3-7
 - location, 2-21
 - part number, 9-21
 - removal, 8-71
 - testing, A-15
 - wiring, 10-24
- customer mode, A-18

D

- DC power, 2-49
 - LVPS part number, 9-35
 - troubleshooting, 4-15
 - wiring, 10-17
- Developer Assembly, 2-43
 - cleaning, 7-3
 - life count reset, 6-7
 - part number, 9-29
 - removal, 8-82
 - shipping restraint, 9-58
- Developer Drive Motor, 2-23
 - connector location, 10-6
 - drive train, 2-25
 - failure error, 3-8
 - part number, 9-33
 - precautions, A-13
 - removal, 8-93
 - wiring, 10-19
- Developer Frame Assembly, 2-43
 - frame guides, 9-29
 - part number, 9-29
 - precautions, 8-78
 - removal, 8-78

- Diagnostic Fault History, 4-9
 - display format, 4-10
 - fault history menu, A-11
 - operation, 4-11
- Door A, 1-5
 - close front door error, 3-6
- Link
 - part number, 9-19
 - removal, 8-96
 - location, 1-5
- Door B, 1-5
 - close front door error, 3-6
 - location, 1-5
 - Stopper Strap, 8-49
 - part number, 9-19
- Door C
 - location, 8-7
 - part number, 9-5
 - removal, 8-14
- Duplex Jam Sensor, 2-34
 - actuator, 8-56
 - location, 2-20
 - part number, 9-25
 - removal, 8-54
 - testing, A-14
 - wiring, 10-26
- Duplex Motor, 2-34
 - connector location, 10-5
 - drive train, 2-35
 - gear kit, 9-25
 - gearing, 8-57
 - location, 2-34
 - part number, 9-25
 - removal, 8-57
- duplicate IP address, 3-65

E

- EEPROM Board, 2-48
 - connector location, 10-6
 - location, 2-48
 - part number, 9-35
 - removal, 8-103
 - wiring, 10-24
- EEPROM error, 4-5

- Engine Control Board, 2-49
 - connectors, 10-7
 - fault isolation, 4-5
 - firmware failure error, 3-7
 - location, 2-48
 - NVRAM
 - failure error, 3-8
 - location, 8-107
 - removal, 8-107
 - part number, 9-35
 - removal, 8-104
 - save/restore data, A-16
- engine error history, 3-3
- engine error log, 3-3
 - display, 3-3
 - format, 3-3
- engine test print, 5-9
- enhanced mode, 2-6
- envelopes
 - supported sizes, 1-17
- error message summary, 3-6
- error messages
 - abbreviations used, 3-5
 - Control Panel, 3-6
 - fatal errors, 3-7
 - jam errors, 3-6
 - list of errors, 3-6
 - POST, 4-3
 - printer status, A-4
 - Status page, 3-3
 - warnings, 3-8
- Ethernet Port, 1-2
 - configuration, 6-5
 - location, 1-7
 - operational testing, 4-23, 4-26
 - POST testing, 4-3

F

Fan

- Fuser Fan, 2-37
 - connector location, 10-5
 - fan failure error, 3-7
 - part number, 9-23
 - removal, 8-66
 - wiring, 10-19

- Rear Fan, 2-48
 - connector location, 10-6
 - failure error, 3-7
 - part number, 9-5
 - removal, 8-102
 - wiring, 10-17

- testing, A-12

fasteners

- Hardware Kit, 9-63
- harness guide clamps, 9-35
- precautions, 8-3
- screws, 8-4

fatal errors, 3-7

Feed Roller

- life count, 1-12
- location, 1-10
- operation, 2-41
- removal, 8-32

Tray 1 (MPT)

- location, 2-34
- part number, 9-23

Feed Roller Kit

- contents, 9-60
- part number, 9-58

Feed Solenoid, 2-42

Feeder Chute

- part number, 9-9
- removal, 8-21

fonts

- reset defaults, 6-6
- supplied fonts, 1-2

Front Cover

- part number, 9-5
- removal, 8-10

Full Stack Sensor, 2-34

- actuator removal, 8-53
- connector location, 10-5
- location, 2-20
- output tray full error, 3-7
- part number, 9-25
- removal, 8-52
- testing, A-14
- wiring, 10-26

Fuser, 2-37

- belt, 2-38
- components, 2-38

- connector location, 10-6
 - Drive Assembly, 2-29
 - part number, 9-21
 - removal, 8-96
 - Exit Roller, 2-38
 - Exit Sensor, 2-38
 - actuator removal, 8-68
 - location, 2-20
 - failure error, 3-7
 - Fan, 2-37
 - connector location, 10-5
 - location, 2-37
 - part number, 9-23
 - wiring, 10-19
 - firmware failure error, 3-7
 - Heat Roller, 2-38
 - install or reseal error, 3-7
 - jam error, 3-6
 - life count, 1-12
 - location, 1-10
 - Lock Lever
 - part number, 9-21
 - removal, 8-69
 - non-6300 fuser error, 3-6
 - Non-contact Sensor, 2-38
 - part number, 9-19
 - removal, 8-5
 - replace fuser error, 3-6
 - temperature
 - regulation, 2-15
 - sensing, 2-18
 - testing, A-15
 - view life count, 6-9
 - wiring diagram, 10-22
 - Fuser Exit Sensor, 2-38
 - actuator removal, 8-68
 - testing, A-14
 - Fuser Fan, 2-37
 - connector location, 10-5
 - failure error, 3-7
 - removal, 8-66
 - testing, A-12
 - wiring, 10-19
 - Fuser Motor, 2-29
 - connector location, 10-6
 - drive train, 2-29
 - failure error, 3-8
 - location, 2-33
 - part number, 9-21
 - removal, 8-96
 - wiring, 10-19
- G**
- Gear Kit
 - installtion, 8-57
 - part number, 9-58
 - Gear MPT, 2-39
 - location, 2-34
 - general status, A-11
 - guides, 2-40
- H**
- Hard Drive, 1-8
 - failure error, 3-8
 - IDE disk error, 4-4
 - location, 2-48
 - part number, 9-35
 - POST testing, 4-3
 - Hardware Kit
 - contents, 9-63
 - part number, 9-58
 - Harness Kit
 - contents, 9-64
 - part number, 9-58
 - Health LED, 4-2
 - Heat Roller, 2-38
 - heater lamp, 2-38
 - help text, 3-2
 - hidden service menu, 4-8
 - horizontal color registration, 6-3
 - Housing Assembly Bias
 - part number, 9-27
 - removal, 8-77
 - wiring, 10-25
 - HVPS, 2-49
 - connectors, 10-7
 - location, 2-48
 - part number, 9-35
 - removal, 8-109
 - wiring, 10-25

I

- IDE disk error, 4-4
- image intensity, 6-2
- Image Processor Board, 2-48
 - connectors, 10-7
 - CPU interrupts error, 4-5
 - fault isolation, 4-5
 - location, 2-48
 - NVRAM
 - location, 8-98
 - part number, 9-35
 - removal, 8-98
 - NVRAM (EEPROM) error, 4-5
 - part number, 9-35
 - removal, 8-98
 - reseat controller board error, 4-7
 - reset, A-18
 - wiring diagram, 10-27
- image size, 5-7
- Imaging Unit, 2-43
 - cleaning, 7-3
 - components, 2-43
 - harness assembly, 9-29
 - install or reseal error, 3-7
 - life count, 1-12
 - location, 1-10
 - non-Xerox imaging unit error, 3-6
 - part number, 9-27
 - precautions, 8-7
 - removal, 8-5
 - replace imaging unit error, 3-6
 - view life counts, 6-9
 - waste toner reservoir, 2-4
 - wiring, 10-25
- Interlock Switch, 4-14
 - connector location, 10-6
 - location, 2-20
 - operation, 4-14
 - part number, 9-35
 - removal, 8-101
 - testing, A-14
 - wiring, 10-17

J

- jam error log, 3-3
 - format, 3-3
- jam errors, 3-6
- jam history, 3-3
- job collation, 1-2

L

- Laser Unit, 2-44
 - cleaning, 7-4
 - components, 2-44
 - failure error, 3-7
 - operation, 2-8
 - part number, 9-27
 - precautions, 8-76
 - removal, 8-76
 - wiring diagram, 10-23
- LED
 - blink patterns, 4-5
 - color definitions, 1-6
 - Health LED, 4-2
- Link
 - part number, 9-19
 - removal, 8-59
- Long-Life Maintenance Kit, 7-4
 - contents, 9-62
 - installation, 7-4
 - life count, 1-12
 - part number, 9-58
 - replace maintenance kit error, 3-8
 - reset counter, 6-7
- Low Paper Sensor, 2-42
 - connector location, 10-8
 - part number, 9-13
 - removal, 8-29
- LVPS, 2-49
 - connectors, 10-6
 - location, 2-48
 - overcurrent protection, 4-13
 - overvoltage protection, 4-13
 - part number, 9-35
 - removal, 8-99
 - troubleshooting, 4-14
 - wiring diagram, 10-17

M

Macintosh printing problems, 4-20

Main Drive Motor, 2-27

connector location, 10-6

drive train, 2-28

motor failure error, 3-8

part number, 9-33

removal, 8-95

wiring, 10-19

margins

adjustment, 6-2

restore defaults, 6-5

measurement techniques, 3-9

media errors, 3-7

Memory, 1-12

errors, 4-3

location, 2-48

maximum, 1-12

minimum, 1-12

options, 1-8

part number, 9-35

POST testing, 4-3

supported types, 1-12

upgrades, 9-59

metered printing, 1-4

Microswitch, 2-18

Mode, A-18

Mode Select Port, A-18

location, 1-7

operation, A-18

wiring, 10-27

modes

print quality, 2-6

Motor

1100-Sheet Feeder

Drive, 2-53

550-Sheet Feeder

Drive, 2-58

Developer Drive, 2-23

connector location, 10-6

location, 2-22

motor failure error, 3-8

removal, 8-93

wiring, 10-19

Duplex, 2-34

connector location, 10-5

location, 2-34

removal, 8-57

wiring, 10-19

Fuser, 2-33

connector location, 10-6

location, 2-33

motor failure error, 3-8

removal, 8-96

wiring, 10-19

Main Drive, 2-27

connector location, 10-6

location, 2-22

motor failure error, 3-8

removal, 8-95

wiring, 10-19

testing, A-12

Toner

connector location, 10-5

drive train, 2-46

location, 2-45

wiring, 10-21

N

network

Apple troubleshooting, 4-20

Ethernet Port, 1-7

log format, 4-25

logging, 4-25

remote access, 4-25

restore defaults, 6-5

troubleshooting, 4-23

Network Diagnostics, 4-23

No Paper Sensor, 2-41

connector location, 10-8

part number, 9-13

removal, 8-28

testing, A-15

No Toner Sensor, 2-46

connector location, 10-5

part number, 9-31

removal, 8-87

wiring, 10-20

Non-contact Sensor, 2-38

- NVRAM
 - location, 2-48
 - POST testing, 4-3
 - reset postscript, 6-8
 - save and restore, 6-8
 - supported types, 1-12
 - utilities, A-16

- O**
- Option Feeder Harness (OPFPLG)
 - connector location, 10-8
 - part number, 9-11
 - removal, 8-26
- options, 1-8
- output tray, 1-2

- P**
- PagePack, 1-4
- Paper Feed Roller, Tray, 8-20
- paper guides, 2-40
- paper path, 2-16
 - flow diagram, 2-17
 - sensing, 2-19
 - sensor locations, 2-20
- Paper Pick Assembly, 2-41
 - components, 2-41
 - connector locations, 10-8
 - operation, 2-41
- paper size detection, 2-7
- Paper Size Switch
 - connector location, 10-8
 - part number, 9-11
 - removal, 8-25
 - size indication, 2-7
- personal print, 1-2
- photo mode, 2-6
- power cord, 9-35
- Power On Self Test (POST)
 - bypass testing, 4-3
 - description, 4-3
 - error indications, 4-3
 - fault types, 4-3
 - hard faults, 4-5
 - error display, 4-5
 - LED blink patterns, 4-5
 - types, 4-5
 - Health LED, 4-2
 - indicators, 4-2
 - memory error correction, 4-16
 - soft faults, 4-4
 - corrective actions, 4-4
 - Startup page format, 4-4
 - types, 4-4
 - version, 4-2
- power requirements, 1-12
- power saver mode, 1-14
- Power Switch, 2-49
- preventative maintenance, 7-4
- print quality
 - analyzing test prints, 5-7
 - CMYK test print, 5-4
 - defect analysis, 5-2
 - defects by component, 5-3
 - margins, 5-8
 - paper tips page, 5-2
 - registration, 5-8
 - repeating defects, 5-2
 - troubleshooting, 5-2
- Printer, 1-2
 - boot sequence, 4-2
 - chassis removal, 8-23
 - cleaning, 7-2
 - configurations, 1-3
 - dimensions, 1-13
 - error reporting, 3-2
 - image area, 1-15
 - memory configurations, 1-8
 - menu map, A-2
 - metered operation, 1-4
 - operational characteristics, 1-14
 - operational modes
 - customer mode, A-18
 - service mode, A-18
 - options, 1-8
 - paper path, 2-16
 - power consumption, 1-12
 - power requirements, 1-12
 - required minimum clearances, 1-13
 - sensor types, 2-18
 - status codes, A-4

- view total page count, 6-9
- print-quality modes, 2-6
- proof print, 1-2

R

- Rear Fan, 2-48
 - connector location, 10-6
 - failure error, 3-7
 - location, 2-48
 - removal, 8-102
 - testing, A-12
 - wiring, 10-17
- Rear Panel, 1-7
 - layout, 1-7
- registration, 5-7
 - color registration page, 6-3
 - horizontal adjustment, 6-3
 - restore defaults, 6-4
- Registration Chute, 2-32
 - part number, 9-15
 - removal, 8-34
- Registration Roller, 2-30
 - components, 2-31
 - jam error, 3-6
 - part number, 9-17
 - removal, 8-38
- Registration Sensor, 2-31
 - actuator removal, 8-35
 - connector location, 10-7
 - location, 2-20
 - part number, 9-15
 - removal, 8-36
 - testing, A-14
 - wiring, 10-26
- resolution, 1-14
- routine maintenance, 7-4
 - errors, 3-6
 - life counts, 1-11

S

- screw types, 8-4
- secure print, 1-2
- Sensor, 2-18
 - CTD (ADC) Sensor, 2-11

- connector location, 10-6
- location, 2-21
- part number, 9-21
- removal, 8-71
- testing, A-15
- Duplex Jam Sensor, 2-34
 - location, 2-20
 - removal, 8-54
 - testing, A-14
- Full Stack Sensor, 2-34
 - location, 2-20
 - part number, 9-25
 - removal, 8-52
 - testing, A-14
- Fuser Exit Sensor, 2-37
 - location, 2-20
 - testing, A-14
- Low Paper Sensor, 2-42
 - location, 2-20
 - part number, 9-13
 - testing, A-14
- microswitch, 2-18
- No Paper Sensor, 2-41
 - location, 2-20
 - part number, 9-13
 - testing, A-15
- No Toner Sensor, 2-14
 - connector location, 10-5
 - location, 2-21
 - part number, 9-31
 - removal, 8-87
 - wiring, 10-20
- Non-contact Sensor, 2-38
 - photo-receptive, 2-18
 - photo-reflective, 2-18
- Registration Sensor, 2-31
 - connector location, 10-7
 - location, 2-20
 - part number, 9-15
 - removal, 8-36
 - testing, A-14
- Temp/Humidity Sensor, 2-41
 - location, 2-21
 - part number, 9-35
 - removal, 8-108
 - testing, A-14

- thermistor, 2-18
- Toner Cartridge In, 2-46
 - location, 2-21
 - removal, 8-89
 - testing, A-14
- Toner Full Sensor, 2-13
 - connector location, 10-6
 - location, 2-21
 - part number, 9-21
 - removal, 8-72
 - testing, A-15
- types, 2-18
- Sensor Acuator Kit
 - contents, 9-62
 - part number, 9-58
- Serial Debug Port, 1-7
 - back channel trace, A-19
 - location, 1-7
 - operation, A-18
 - wiring, 10-27
- serial number
 - location, 9-2
- Service Diagnostics, 4-6
 - button functions, 4-7
 - diagnostic fault history, 4-9
 - exiting, 4-8
 - main menu, 4-6
 - menu map, A-10
 - print menu map, 4-7
 - reseat controller board error, 4-7
 - starting, 4-7
 - status reporting, 4-9
 - test descriptions, A-11
 - test print generation, 4-9
- Service Kits, 9-60
 - Chute Gear Kit
 - part number, 9-58
 - Feed Roller Kit
 - contents, 9-60
 - part number, 9-58
 - Hardware Kit
 - contents, 9-63
 - part number, 9-58
 - Harness Kit
 - contents, 9-64
 - part number, 9-58
 - Long-Life Maintenance Kit
 - contents, 9-62
 - part number, 9-58
 - Sensor Acuator Kit
 - contents, 9-62
 - part number, 9-58
 - Spring Kit
 - contents, 9-61
 - part number, 9-58
 - Tray Holder Kit
 - part number, 9-58
- service mode, A-18
- Service Usage Profile, 3-3
 - description, 3-3
 - engine error log, 3-3
 - display format, 3-3
 - error logging, 3-3
- Solenoid tests, A-16
- Specifications, 1-12
 - electrical, 1-12
 - environmental, 1-16
 - functional, 1-14
 - image, 1-15
 - media, 1-17
 - memory, 1-12
- Spring Kit
 - contents, 9-61
 - part number, 9-58
- standard mode, 2-6
- Startup page
 - network parameters, 4-20
 - POST error reports, 4-4
- startup process, 4-2
- status codes, A-4
- Status page, 3-3
- Stopper Strap
 - part number, 9-19
 - removal, 8-49

T

- Temp/Humidity Sensor, 2-41
 - connector location, 10-8
 - location, 2-21
 - part number, 9-35
 - removal, 8-108

- sensor failure error, 3-8
- wiring, 10-22
- test pattern sample, 5-6
- test print, 5-4
 - 600 x 600 test print, 5-8
 - analyzing, 5-7
 - CMYK test print, 5-4
 - engine test print, 5-9
 - Service Diagnostics test prints, A-11
 - service test print, 5-8
 - setting test parameters, A-12
- Test Print Button, 5-9
 - location, 1-7
 - operation, 5-9
- Thermistor, 2-18
- Toner
 - density control, 2-11
 - life count, 1-12
 - metered, 1-4
 - presence detect, 2-14
 - transport, 2-47
- Toner Cartridge, 2-45
 - failure error, 3-8
 - metered cartridges, 1-4
 - part number, 9-60
 - presence detect, 2-14
 - removal, 8-6
 - remove ribbon error, 3-7
 - replace toner cartridge error, 3-7
 - validation, 6-9
 - view life count, 6-9
- Toner Cartridge Assembly, 2-45
- Toner Cartridge Holder, 2-45
 - components, 2-45
 - part number, 9-31
 - removal, 8-85
- Toner Cartridge In Sensor, 2-46
 - actuator part number, 9-31
 - bracket part number, 9-31
 - removal, 8-89
- Toner Full Sensor, 2-33
 - connector location, 10-6
 - location, 2-21
 - part number, 9-21
 - removal, 8-72
 - testing, A-15
- wiring, 10-24
- Toner Motor, 2-46
 - connector location, 10-5
 - drive train, 2-46
 - location, 2-45
 - precautions, A-13
 - testing, A-13
 - wiring, 10-21
- Transfer Roller, 2-37
 - install or reseal error, 3-7
 - life count, 1-12
 - life count reset, 6-9
 - location, 1-10
 - part number, 9-19
 - presence detect, 2-13
 - removal, 8-5
 - replace transfer roller error, 3-6
- Toner Full Sensor, 2-13
- waste toner reservoir, 2-4
 - status, 2-13
- Tray, 2-40
 - capacity, 1-18
 - components, 2-40
- Feed Roller
 - removal, 8-32
 - replacement kit, 9-60
- Feeder Chute
 - part number, 9-9
- guides, 2-40
- insert Tray 2~5 error, 3-7
- Label Kit, 9-59
- Low Paper Sensor
 - connector location, 10-8
 - part number, 9-13
 - removal, 8-29
 - testing, A-14
- misfeed (jam T2~5) error, 3-6
- No Paper Sensor
 - part number, 9-13
 - removal, 8-28
- numbering, 2-7
- optional trays, 1-9
- out of paper, load tray 2~5 error, 3-7
- paper handling, 6-5
- paper is low error, 3-8

- Paper Pick Assembly
 - part number, 9-13
 - part number, 9-7
 - Rear Cover
 - part number, 9-9
 - removal, 8-22
 - Retard Roller
 - part number, 9-7
 - removal, 8-20
 - tray missing warning, 3-8
 - Tray 1 (MPT), 8-40
 - components, 2-39
 - Feed Roller, 2-39
 - part number, 9-23
 - removal, 8-49
 - Feed Solenoid, 2-39
 - connector location, 10-5
 - location, 2-34
 - part number, 9-23
 - removal, 8-41
 - wiring, 10-26
 - misfeed (jam T1) error, 3-6
 - No Paper Sensor, 2-39
 - connector location, 10-5
 - part number, 9-23
 - removal, 8-45
 - testing, A-15
 - wiring, 10-26
 - operation, 2-39
 - out of paper, load tray error, 3-7
 - paper handling, 6-5
 - Retard Roller, 2-30
 - part number, 9-15
 - removal, 8-37
 - Tray Holder Kit
 - part number, 9-58
 - troubleshooting
 - back channel trace, A-19
 - boot errors, 4-3
 - color calibration, 6-2
 - damaged prints, 4-19
 - diagnostic testing, 4-6
 - error messages, 3-6
 - Fuser jams, 4-19
 - Image Processor Board, 4-5
 - margins, 6-2
 - measurement techniques, 3-9
 - media-based problems, 4-18
 - mis-picks, 4-18
 - multiple-sheet picks, 4-18
 - network connection, 4-23
 - power supply problems, 4-13
 - printing defects, 5-3
 - procedural instructions, 3-9
 - repeating print defects, 5-2
 - skewed images, 4-19
 - Turn Chute, 8-20
 - Turn Clutch, 2-41
 - Turn Roller, 2-42
- ## U
- Universal tray, 2-40
 - part number, 9-58
 - unsupported configuration, 3-8
 - Upper Chute, 8-30
 - removal, 8-30
 - USB Port, 1-7
 - configuration, 6-5
 - location, 1-7
 - operational testing, 4-26
 - POST testing, 4-3
- ## V
- vertical color registration, 6-3
 - voltage
 - frequency ranges, 1-12
 - input requirements, 1-12
 - measured tolerances, 3-10
- ## W
- warm-up time, 1-14
 - warning messages, 3-8
 - waste toner reservoir, 2-4
 - web browsing, 3-2
 - web support, 4-2
 - Windows printing problems, 4-22
- ## X
- Xerox Supplies and Accessories, 9-58

