

WORKCENTRE PE 220

SERVICE MANUAL



XEROX®

708P88337

Service Documentation

708P88337

November 2005

Prepared by:

Xerox Europe,

Global Knowledge & Language Services,

Enterprise Centre,

P.O. Box 17,

Bessemer Road,

Welwyn Garden City,

Hertfordshire,

AL7 1BU, England.

© Copyright 2005 by Xerox Ltd.

Xerox, and all identifying numbers used in connection with the Xerox products mentioned in this publication are registered trademarks of Xerox. Other company trademarks are also acknowledged.

NOTICE

While every care has been taken in the preparation of this manual, no liability will be accepted by Xerox Europe arising out of any inaccuracies or omissions.

All service documentation is supplied to Xerox external customers for informational purposes only. Xerox service documentation is intended for use by certified, product trained service personnel only. Xerox does not warrant or represent that it will notify or provide to such customer any future change to this documentation. Customer performed service of equipment, or modules, components or parts of such equipment may affect whether Xerox is responsible to fix machine defects under the warranty offered by Xerox with respect to such equipment. You should consult the applicable warranty for its terms regarding customer or third-party provided service.

Introduction

Safety Precautions [iii](#)

1. Service Call Procedures

Section Contents [1-1](#)

2. Repair Analysis Procedures

Section Contents [2-1](#)

3. Image Quality

Section Contents [3-1](#)

4. Repairs/Adjustments

Section Contents [4-1](#)

5. Parts List

Section Contents [5-1](#)

6. General Procedures/Information

Section Contents [6-1](#)

7. Wiring Data

Section Contents [7-1](#)

Page intentionally blank

Introduction

Precautions

In order to prevent accidents and to prevent damage to the equipment please read the precautions listed below carefully before servicing the machine and follow them closely.

Safety Warning

1. Only to be serviced by appropriately qualified service engineers.

High voltages and lasers inside this product are dangerous. This machine should only be serviced by a suitably trained and qualified service engineer.

2. Use only Xerox replacement parts

There are no user serviceable parts inside the machine. Do not make any unauthorized changes or additions to the machine, these could cause the machine to malfunction and create electric shock or fire hazards.

3. Laser Safety Statement

The machine is certified in the U.S. to conform to the requirements of DHHS 21 CFR, chapter 1 Subchapter J for Class 1(1) laser products, and elsewhere, it is certified as a Class I laser product conforming to the requirements of IEC 825. Class I laser products are not considered to be hazardous. The laser system and machine are designed so there is never any human access to laser radiation above a Class I level during normal operation, user maintenance, or prescribed service condition.

WARNING

Never operate or service the machine with the protective cover removed from Laser/Scanner assembly. The reflected beam, although invisible, can damage your eyes. When using this product, these basic safety pre-cautions should always be followed to reduce risk of fire, electric shock, and injury to persons.



CAUTION - INVISIBLE LASER RADIATION
WHEN THIS COVER OPEN.
DO NOT OPEN THIS COVER.

VORSICHT - UNSICHTBARE LASERSTRAHLUNG,
WENN ABDECKUNG GEFFNET.
NICHT DEM STRAHL AUSSETZEN.

ATTENTION - RAYONNEMENT LASER INVISIBLE EN CAS
D'OUVERTURE. EXPOSITION DANGEREUSE
AU FAISCEAU.

ATTENZIONE - RADIAZIONE LASER INVISIBLE IN CASO DI
APERTURA. EVITARE L'ESPOSIZIONE AL
FASCIO.

PRECAUCION - RADIACION LASER IVISIBLE CUANDO SE ABRE.
EVITAR EXPONERSE AL RAYO.

ADVARSEL - USYNLIG LASERSTR LNING VED BNING, N R
SIKKERHEDSBRYDERE ER UDE AF FUNKTION.
UNDG UD SAETTELSE FOR STR LNING.

ADVARSEL - USYNLIG LASERSTR LNING N R DEKSEL
PNES. STIRR IKKE INN I STR LEN.
UNNG EKSPONERING FOR STR LEN.

VARNING - OSYNLIG LASERSTR LNING N R DENNA DEL
R PPNAD OCH SP RREN R URKOPPLAD.
BETRAKTA EJ STR LEN. STR LEN R FARLIG.

VARO! - AVATTAESSA JA SUOJALUKITUS OHITETTAESSA
OLET ALTTIINA N KYM TT M LLE LASER-
S TEILYLLE L KATSO S TEESEEN.

注 意 - 严禁揭开此盖, 以免激光泄露灼伤

주 의 - 이 덮개를 열면 레이저광에 노출될 수 있으므로
주의하십시오.

Caution for safety

Toxic material

This product contains toxic materials that could cause illness if ingested.

1. If the LCD control panel is damaged it is possible for the liquid inside to leak. This liquid is toxic. Contact with the skin should be avoided, wash any splashes from eyes or skin immediately and contact your doctor. If the liquid gets into the mouth or is swallowed see a doctor immediately.
2. Please keep print cartridges away from children. The toner powder contained in the print cartridge may be harmful and if swallowed you should contact a doctor.

Electric Shock and Fire Safety Precautions

Failure to follow the following instructions could cause electric shock or potentially cause a fire.

1. Use only the correct voltage, failure to do so could damage the machine and potentially cause a fire or electric shock.
2. Use only the power cable supplied with the machine. Use of an incorrectly specified cable could cause the cable to overheat and potentially cause a fire.
3. Do not overload the power socket, this could lead to overheating of the cables inside the wall and could lead to a fire.
4. Do not allow water or other liquids to spill into the machine, this can cause electric shock. Do not allow paper clips, pins or other foreign objects to fall into the machine these could cause a short circuit leading to an electric shock or fire hazard.
5. Never touch the plugs on either end of the power cable with wet hands, this can cause electric shock. When servicing the machine remove the power plug from the wall socket.
6. Use caution when inserting or removing the power connector. The power connector must be inserted completely otherwise a poor contact could cause overheating possibly leading to a fire. When removing the power connector grip it firmly and pull.
7. Take care of the power cable. Do not allow it to become twisted, bent sharply round corners or otherwise damaged. Do not place objects on top of the power cable. If the power cable is damaged it could overheat and cause a fire or exposed cables could cause an electric shock. Replace a damaged power cable immediately, do not reuse or repair the damaged cable. Some chemicals can attack the coating on the power cable, weakening the cover or exposing cables causing fire and shock risks.
8. Ensure that the power sockets and plugs are not cracked or broken in any way. Any such defects should be repaired immediately. Take care not to cut or damage the power cable or plugs when moving the machine.
9. Use caution during thunder or lightning storms. Xerox recommend that this machine be disconnected from the power source when such weather conditions are expected. Do not touch the machine or the power cord if it is still connected to the wall socket in these weather conditions.
10. Avoid damp or dusty areas, install the machine in a clean well ventilated location. Do not position the machine near a humidifier. Damp and dust build up inside the machine can lead to overheating and cause a fire.
11. Do not position the machine in direct sunlight. This will cause the temperature inside the machine to rise possibly leading to the machine failing to work properly and in extreme conditions could lead to a fire.
12. Do not insert any metal objects into the machine through the ventilator fan or other part of the casing, it could make contact with a high voltage conductor inside the machine and cause an electric shock.

Handling Precautions

The following instructions are for your own personal safety, to avoid injury and so as not to damage the machine

1. Ensure the machine is installed on a level surface, capable of supporting its weight. Failure to do so could cause the machine to tip or fall.
2. The machine contains many rollers, gears and fans. Take great care to ensure that you do not catch your fingers, hair or clothing in any of these rotating devices.
3. Do not place any small metal objects, containers of water, chemicals or other liquids close to the machine which if spilled could get into the machine and cause damage or a shock or fire hazard.
4. Do not install the machine in areas with high dust or moisture levels, beside an open window or close to a humidifier or heater. Damage could be caused to the machine in such areas.
5. Do not place candles, burning cigarettes, etc. on the machine, these could cause a fire.

Assembly / Disassembly Precautions

Replace parts carefully, always use Xerox parts. Take care to note the exact location of parts and also cable routing before dismantling any part of the machine. Ensure all parts and cables are replaced correctly.

Please carry out the following procedures before dismantling the machine or replacing any parts.

1. Check the contents of the machine memory and make a note of any user settings. These will be erased if the mainboard is replaced.
2. Ensure that power is disconnected before servicing or replacing any electrical parts.
3. Disconnect printer interface cables and power cables.
4. Only use approved spare parts. Ensure that part number, product name, any voltage, current or temperature rating are correct.
5. When removing or re-fitting any parts do not use excessive force, especially when fitting screws into plastic.
6. Take care not to drop any small parts into the machine.
7. Handling of the OPC Drum

- The OPC Drum can be irreparably damaged if it is exposed to light.

Take care not to expose the OPC Drum either to direct sunlight or to fluorescent or incandescent room lighting. Exposure for as little as 5 minutes can damage the surface's photoconductive properties and will result in print quality degradation. Take extra care when servicing the machine. Remove the OPC Drum and store it in a black bag or other lightproof container. Take care when working with the covers (especially the top cover) open as light is admitted to the OPC area and can damage the OPC Drum.

- Take care not to scratch the green surface of the OPC Drum Unit.

If the green surface of the Drum Cartridge is scratched or touched the print quality will be compromised.

Disregarding this warning may cause bodily injury

1. Be careful with the high temperature part.
The fuser unit works at a high temperature. Use caution when working on the machine. Wait for the fuser to cool down before disassembly.
2. Do not put fingers or hair into the rotating parts (paper feeding entrance, motor, fan, etc.). Doing so may cause injury.
3. When you move the machine.
This machine weighs 10.4kg including print cartridge and cassette. Use safe lifting and handling techniques. Back injury could be caused if you do not lift carefully.
4. Ensure the machine is installed safely.
The machine weighs 10.4Kg, ensure the machine is installed on a level surface, capable of supporting its weight. Failure to do so could cause the machine to tip or fall possibly causing personal injury or damaging the machine.
5. Do not install the machine on a sloping or unstable surface. After installation, double check that the machine is stable.

ESD Precautions

Certain semiconductor devices can be easily damaged by static electricity. Such components are commonly called “Electrostatically Sensitive (ES) Devices”, or ESDs. Examples of typical ESDs are: integrated circuits, some field effect transistors, and semiconductor “chip” components. The techniques outlined below should be followed to help reduce the incidence of component damage caused by static electricity.

CAUTION

Be sure no power is applied to the chassis or circuit, and observe all other safety precautions.

1. Immediately before handling a semiconductor component or semiconductor-equipped assembly, drain off any electrostatic charge on your body by touching a known earth ground. Alternatively, employ a commercially available wrist strap device, which should be removed for your personal safety reasons prior to applying power to the unit under test.
2. After removing an electrical assembly equipped with ESDs, place the assembly on a conductive surface, such as aluminium or copper foil, or conductive foam, to prevent electrostatic charge buildup in the vicinity of the assembly.
3. Use only a grounded tip soldering iron to solder or desolder ESDs.
4. Use only an “anti-static” solder removal device. Some solder removal devices not classified as “anti-static” can generate electrical charges sufficient to damage ESDs.
5. Do not use Freon-propelled chemicals. When sprayed, these can generate electrical charges sufficient to damage ESDs.
6. Do not remove a replacement ESD from its protective packaging until immediately before installing it. Most replacement ESDs are packaged with all leads shorted together by conductive foam, aluminium foil, or a comparable conductive material.
7. Immediately before removing the protective shorting material from the leads of a replacement ESD, touch the protective material to the chassis or circuit assembly into which the device will be installed.

8. Maintain continuous electrical contact between the ESD and the assembly into which it will be installed, until completely plugged or soldered into the circuit.
9. Minimize bodily motions when handling unpackaged replacement ESDs. Normal motions, such as the brushing together of clothing fabric and lifting one's foot from a carpeted floor, can generate static electricity sufficient to damage an ESD.

Super Capacitor or Lithium Battery Precautions

1. Exercise caution when replacing a super capacitor or Lithium battery. There could be a danger of explosion and subsequent operator injury and/or equipment damage if incorrectly installed.
2. Be sure to replace the battery with the same or equivalent type recommended by the manufacturer.
3. Super capacitor or Lithium batteries contain toxic substances and should not be opened, crushed, or burned for disposal.
4. Dispose of used batteries according to the manufacturers instructions.

Print Cartridge Service

Only print cartridges supplied by Xerox should be used. Printing defects or set damage caused by the use of non-approved print cartridges or un-licensed toner refills are not covered by the guarantee.

Precautions on Safe-keeping of Print Cartridge

Excessive exposure to direct light for more than a few minutes may cause damage to the cartridge.

Service for the Life of Print Cartridge

If the printed image is light due to the toner supply becoming low you can temporarily improve the print quality by redistributing the toner (Shake the print cartridge), however you should replace the print cartridge to solve the problem permanently.

Redistributing Toner

When the print cartridge is near the end of its life, white streaks or light print occurs. The LCD displays the warning message, "Toner Low." You can temporarily re-establish the print quality by redistributing the remaining toner in the cartridge.

Standard of guarantee for consumable parts.

Please refer to User Manual or Instructions on Fax/Printer Consumables SVC manual for the criteria for judging the quality of consumable parts the standard of guarantee on those parts.

• Spotting a refilled cartridge by eye.

One way security screws are used in the manufacture of the cartridge – check if these are damaged.

Health and Safety Incident Reporting

I. Summary

This section defines requirements for notification of health and safety incidents involving Xerox products (equipment and materials) at customer locations.

II. Scope

Xerox Corporation and subsidiaries worldwide.

III. Objective

To enable prompt resolution of health and safety incidents involving Xerox products and to ensure Xerox regulatory compliance.

IV. Definitions

Incident:

An event or condition occurring in a customer account that has resulted in injury, illness or property damage. Examples of incidents include machine fires, smoke generation, physical injury to an operator or service representative. Alleged events and product conditions are included in this definition.

V. Requirements

Initial Report:

1. Xerox organisations shall establish a process for individuals to report product incidents to Xerox Environment Health & Safety within 24 hours of becoming aware of the event.
2. The information to be provided at the time of reporting is contained in Appendix A (Health and Safety Incident Report involving a Xerox product).
3. The initial notification may be made by any of the following methods:
 - For incidents in North America and Developing Markets West (Brazil, Mexico, Latin American North and Latin American South):
 - Phone* Xerox EH&S at: 1-800-828-6571.
 - Electronic mail Xerox EH&S at: Doris.Bush@usa.xerox.com.
 - Fax Xerox EH&S at: 1-585-422-6449 [intelnet 8*222 6449].
 - For incidents in Europe and Developing Markets East (Middle East, Africa, India, China and Hong Kong):
 - Phone* Xerox EH&S at: +44 (0) 1707 353434.
 - Electronic mail Xerox EH&S at: Elaine.Grange@GBR.xerox.com.
 - Fax Xerox EH&S at: +44 (0) 1707 353914 [intelnet 8*668 3914].

*Initial notification made by phone must be followed within 24 hours by a completed incident report and sent to the indicated electronic mail address or fax number.

Note: *If sending a fax, please also send the original via internal mail.*

Responsibilities for Resolution:

1. Business Groups/Product Design Teams responsible for the product involved in the incident shall:
 - a. Manage field bulletins, customer correspondence, product recalls, safety retrofits.
 - b. Fund all field retrofits.
1. Field Service Operations shall:
 - a. Preserve the Xerox product involved and the scene of the incident inclusive of any associated equipment located in the vicinity of the incident.
 - b. Return any affected equipment/part(s) to the location designated by Xerox EH&S and/or the Business Division.
 - c. Implement all safety retrofits.
2. Xerox EH&S shall:
 - a. Manage and report all incident investigation activities.
 - b. Review and approve proposed product corrective actions and retrofits, if necessary.
 - c. Manage all communications and correspondence with government agencies.
 - d. Define actions to correct confirmed incidents.

VI. Appendices

The Health and Safety Incident Report involving a Xerox Product (Form # EH&S-700) is available at the end of the manual.

1. Service Call Procedures

SCP 1 Service Call Actions	<u>1-3</u>
SCP 2 Final Actions	<u>1-4</u>

Page intentionally blank

SCP 1 Service Call Actions

Procedure

Throughout this manual, observe the following Warnings:

WARNING

Switch off the electricity to the machine. Disconnect the power cord from the customer supply while performing tasks that do not need electricity. Electricity can cause death or injury. Moving parts can cause injury.

WARNING

Do not touch the fuser while it is hot.

WARNING

Take care during this procedure. Sharp edges may be present that can cause injury.

1. Take note of symptoms or error messages.
2. Ask the operator to describe or demonstrate the problem.
3. Make sure that:
 - The power cord is connected to the wall outlet and to the machine.
 - All cables are connected correctly.
4. If available, check the machine service log book for any previous actions that may be relevant to the call.
5. Review any defective print or copy samples.
6. Perform [1 Initial Checks RAP](#).

SCP 2 Final Actions

Final Actions are used to evaluate the total operation of the system and to identify the actions required to complete the service call.

Procedure

- Exercise the machine in all modes.
- Make a proof copy or print of a customer document.
- If any of the customers selections were changed, return them to the customers preferred settings.
- Mark off any hardware/software options and modifications installed and/or enabled on the Service Log book.
- At the first service and at any subsequent service where changes are made or options are added, print the configuration report and store it with the machine log book. Discard any previous versions of the configuration report.
- Remove and destroy any copies of test patterns.
- Complete the machine service log book, refer to [GP 14](#) Service Log.
- Ensure the machine and service area are clean before leaving the customer premises.
- Provide customer training if required.

2. Status Indicator RAPs

1 Initial Checks RAP	2-3
2 JAM 0 RAP	2-5
3 JAM 1 RAP	2-6
4 JAM 2 RAP	2-7
5 Multi-Feeding RAP	2-8
6 Fuser Jam RAP	2-9
7 Paper rolled in the Print Cartridge (OPC Drum) RAP	2-10
8 Control Panel RAP	2-11
9 Paper Empty RAP	2-12
10 Cover Open RAP	2-13
11 No Power RAP	2-14
12 Bad Software Environment RAP	2-15
13 Abnormal Printing RAP	2-17
14 SPOOL Error RAP	2-18
15 Fax & Phone Problems RAP	2-19
16 Abnormal Noise RAP	2-24
17 Scanning RAP	2-25
18 Print Cartridge Problems RAP	2-26
19 Software Problems RAP	2-27

Page intentionally blank

1 Initial Checks RAP

Basic Check List

1. Check the Power.

- Does "Warming Up" appear on the display?
--> If not check power cable, switch or SMPS.
--> Does the wall socket work?
- Do the Motors or other components initialize (listen for main motor, fan and LSU sounds)?
--> If not or there are none of the normal startup sounds check cable, switch or SMPS.
--> Does the wall socket work?

2. Check the LCD Panel.

- Refer to [General Procedures](#).
- Is there any display at all?
--> If not check power cable, switch or SMPS.
- Is the display a meaningful message. Are there any broken or badly formed characters?
- Is the message on the LCD Panel a standard error message? Refer to [GP 6](#).
--> Does the wall socket work?
--> Check the main PBA and cable harness.
--> Refer to [RAP 3](#).

3. Check the Paper Path

- Is there a Paper Jam?
--> Remove any paper fragments caught in the paper path.
- Paper Jam occurs repeatedly at a specific point in the Paper Path
--> Open the fuser cover, Clear jam.
--> Dismantle the machine and carefully inspect the region where the jam occurs.
Especially, check if paper fragments are caught in the Fuser, refer to [REP 16](#).

4. Print the Information Page (Configuration).

- Try printing a test page from a computer.
--> If there is an error, check cables and driver installation.

5. Check the Print Quality.

- Is there a Print Quality Problem?
--> Go to Section 3, [Image Quality](#).

6. Check consumables (toner etc.).

- Using the keys print the Test Pattern.
--> Expected life of various consumable parts, compare this with the figures printed and replace as required
Enter Tech mode, [GP 4](#). Check the CRU print count. If necessary, install a new print cartridge, [PL 1](#).

Initial Inspection

1. Check the power.

1. The machine does not work no matter how long you wait.
 - A. Is the Power Switch (machine and wall socket) turned on?
 - B. Is the Power Cord connected to the machine correctly?
 - C. Is the Power cord connected to the wall socket correctly?
 - D. Is wall socket working?
 - E. Is the unit rated at the same voltage as the supply?
2. Does the Fan work when power is turned on?
 - A. Check the connectors on the SMPS.
 - B. Check the fuses in the SMPS (F1).

2. Check the Installation Environment.

1. Ensure the installation surface is flat, level and free from vibration.
If necessary move the machine.
2. Ensure that the temperature and humidity of the surroundings are within specification
If necessary move the machine.
3. Ensure that the machine is positioned away from any air conditioning or other heating or cooling equipment. Also ensure that is not positioned in a direct draft from any air conditioning, fan or open window.
If necessary move the machine.
4. Ensure the machine is not positioned in direct sunlight.
If it is unavoidable use a curtain to shade the machine.
5. Ensure the machine is installed in a clean dust free environment.
Move the machine to clean area if necessary.
6. Some industrial or cleaning processes give of fumes which can affect the machine.
Move the machine away from this type of air pollution

3. Check paper type.

1. Use only paper which is of a suitable quality, weight and size.
See the user guide.

4. Check the overall condition of the machine

1. Clean the Paper Transport areas.
Any rollers with dirt surfaces should be cleaned or replaced.

2 JAM 0 RAP

Description

Paper is not exited from the cassette.
Jam-0 occurs if the paper feeds into the machine.

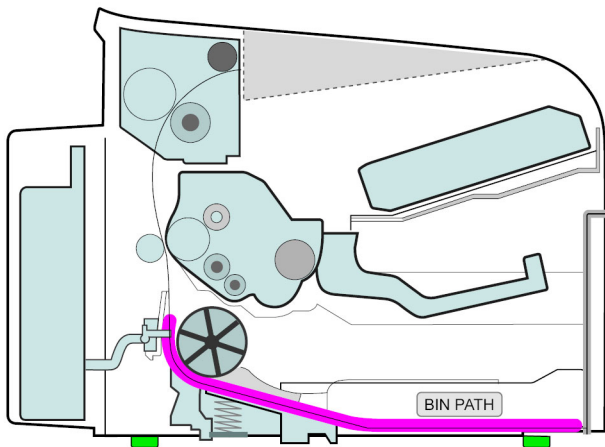

Check and Cause	Solution
1. Check the Solenoid by using Engine Test Mode-Pick up Test.	1. Replace the solenoid, PL 6 .
2. Check the paper guides in the cassette.	2. Adjust the paper guides. Install new parts as necessary, PL 1 .
3. Check the surface of the roller-pickup for foreign matter.	3. Clean with soft cloth dampened with IPA (Isopropyl Alcohol) or water.
4. If the paper feeds into the machine and Jam 0 occurs, perform Engine Test Mode-Feed Sensor Test. Refer to GP 4 .	4. Replace the SMPS, PL 1 , HVPS, PL 1 or feed sensor actuator, PL 6 .

3 JAM 1 RAP

Description

Paper is jammed in front of or just inside the fuser.

Paper is jammed in the discharge roller and in the fuser just after passing through the Actuator-Feed.

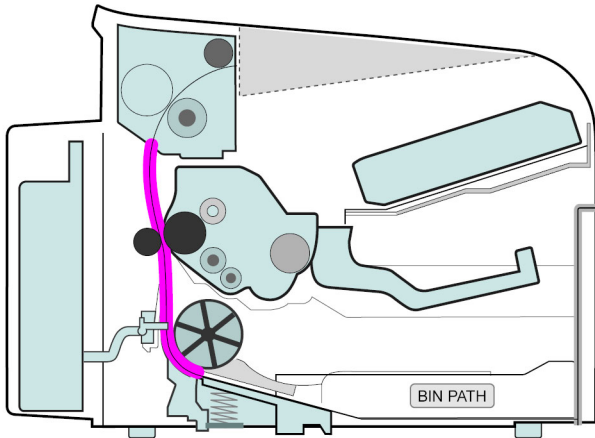

Check and Cause	Solution
1. Check for small pieces of paper jammed in the fuser.	1. Clear paper from the fuser.
2. If paper is jammed in front of or inside the fuser.	2. Replace the SMPS, PL 1 .
3. If paper is jammed in the discharge roller and the fuser just after passing through the Actuator Feed, the Feed Actuator may be defective.	3. Check the actuator for damage, PL 6 .

4 JAM 2 RAP

Description

Paper is jammed inside the fuser.

Paper is jammed in the discharge roller and in the fuser just after passing through the Actuator-Feed.

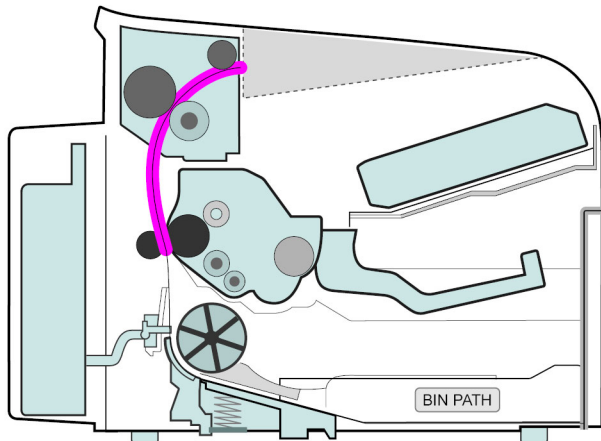

Check and Cause	Solution
<p>1. If the paper is completely fed out of the machine, but Jam 2 occurs: Exit sensor is defective.</p> <ul style="list-style-type: none"> • After the paper is completely fed out, actuator Exit should return to the original position to shut the photo-sensor. Sometimes it takes longer +than it should and does not return. 	<p>1. Check the exit sensor actuator, PL 7.</p>
<p>2. If the paper is rolled in the Fuser Roller:</p> <ul style="list-style-type: none"> • This occurs when a stripper finger is damaged. • It occurs when the Heat-Roller or Pressure-Roller is seriously contaminated, 	<p>2. If the paper is stuck in the fuser: disassemble the fuser and remove the jammed paper. Clean the surface of the pressure roller, heat roller and the stripper fingers. If necessary, install a new fuser, PL 7.</p>

5 Multi-Feeding RAP

Description

Multiple sheets of paper are fed together.

Check and Cause	Solution
1. Badly cut paper.	1. Fan the paper. Recommend the use of good quality paper.
2. Solenoid malfunction (the solenoid does not work properly): Perform Engine Test Mode-Pick up Test. Refer to GP 4 .	2. Replace the solenoid if necessary, PL 6 .
3. Pad-Friction is contaminated with foreign matter.(oil...)	3. Clean the pad friction with soft cloth, dampened with IPA (Isopropyl Alcohol).

6 Fuser Jam RAP

Description

Constant Jam where paper is entering Fuser unit.
Fuser rollers do not turn.

Check and Cause	Solution
1. Check if the fuser has overheated and melted the fuser gear. Check for heat damage to the fuser roll and the pressure roll.	1. Check the Heat Lamp, thermostat and thermistor 2. Use Engine Test Mode, GP 7 , to test the Fuser -THERM ADC 120. 3. Replace Fuser unit. PL 7 . 4. Replace SMPS, PL 1 or Main PBA, PL 1 , as appropriate.

7 Paper rolled in the Print Cartridge (OPC Drum) RAP

Description

Paper is rolled up in the OPC.

Check and Cause	Solution
1. Paper is too thin.	1. Recommend use normal paper. Use paper within specification. Refer to the User Guide.
2. Paper curl.	2. Remove the paper while turning the OPC Drum against the feed direction. Turn the paper over. Recommend the use of good quality 'long grain' paper.

8 Control Panel RAP

8A LCD Defect

Description

Strange characters are displayed in the LCD Window and OPE Panel keys do not work.

Check and Cause	Solution
1. Switch off the machine, then switch on the machine.	1. Try again after clearing the memory.
2. Check that the OPE HARNESS is connected to the Connection Board correctly.	2. If re-connecting the harness does not correct the fault replace the OPE Assembly, PL 5 and the Main board, PL 1 , in sequence.

8B Defective OPE Keypad

Description

Pressing keys does not cause the set to respond correctly.

Check and Cause	Solution
1. Switch off the machine, then switch on the machine.	1. Check that the keypad is assembled correctly and the membrane is not damaged. Replace the membrane or whole keypad assembly if necessary, PL 5 . 2. If the fault remains replace the Main board, PL 1 .

9 Paper Empty RAP

Description

Paper Empty is displayed in the LCD panel even when paper is loaded in the cassette. The paper empty message does not appear in the LCD when the paper cassette is empty.

Check and Cause	Solution
1. Deformed paper sensor actuator or faulty sensor.	1. Replace the defective actuator or sensor, PL 1 .
2. SMPS PBA or Main PBA is defective	2. Replace the SMPS PBA, PL 1 , or Main PBA, PL 1 , as appropriate.
3. Faulty cables or connectors.	3. Check the cables and connectors.
4. Memory error	4. Perform clear all memory, GP 4 .

10 Cover Open RAP

Description

The Cover Open message appears on the LCD even when the print cover is closed.

The Cover Open message does not appear on the LCD even when the print cover is open.

Check and Cause	Solution
1. The 'Open Cover' microswitch may be stuck or faulty	1. Use TECH mode ("cover sensor test"), GP 4 , to check the relevant cover switch operation. Check and replace the switch if necessary, PL 1 . Note: The front cover microswitch is on the HVPS. The rear cover microswitch is on the SMPS.
2. The tab on the front cover may be damaged or broken.	2. Replace the front cover, PL 1 .
3. Check the connector and cables between HVPS and Main PBA, SMPS and Main PBA	3. Install a new harness as necessary, PL 1 . Reseat the connectors. Replace the Main Control board, PL 1 , or HVPS, PL 1 , or SMPS, PL 1 , as necessary.

11 No Power RAP

Description

When system power is turned on the LCD panel does not come on.

Check and Cause	Solution
1. Check fuses on SMPS, PL 1 .	1. Install new fuses or SMPS, PL 1 , as necessary.
2. Check if the power input and SMPS output are normal.	2. Replace the power supply cord or SMPS, PL 1 . Check power fuse and SMPS fuses. Replace if necessary, PL 1 .
3. LCD panel does not come on but normal start up sounds are heard.	3. Replace the OPE unit, PL 5 .
4. After replacing OPE unit display does not come on and no start up sounds are heard.	4. Replace the Main PBA, PL 1 .

12 Bad Software Environment RAP

12A The machine is not working (1)

Description

While Power turned on, the machine is not working in the printing mode.

Check and Cause	Solution
1. Ensure that the customer knows how to install the correct printer driver and to select the PE220 as the default printer.	1. Refer the customer to the PE220 User Guide.
2. Run Self-Test Mode: Turn the power on and select "System Data List" by pressing Menu-Reports-System Data.	2. Check the power of the machine and perform the Self-Test, GP 4 . If the test printing works, that means no problems in the machine itself. If the test printing does not work, that means bad functioning of the machine (not because of software).
3. Check if the PC and the machine is properly connected and the print cartridge installed.	3. Replace the printer cable. If the problems is not solved even after replacing the cable, check the amount of remaining toner.
4. Printing is not working in Windows.	4. Check if the connection between PC and printer port is correct. Uninstall the driver, then re-install new drivers. Refer to Xerox.com. Ask the customer to check the BIOS of the PC to ensure that there are no IRQ conflicts and to check that the input/output range is 0378.
5. Check if the printer cable is directly connected to peripheral devices	5. If the scanner needs to be connected to the machine, remove the scanner from the PC to see if the machine is working alone properly.

12B The machine is not working (2)

Description

After receiving the printing order, no response at all or the low speed of printing occurs due to wrong setup of the environment rather than malfunction of the machine itself.

Check and Cause	Solution
1. Ensure that the customer knows how to install the correct printer driver and to select the PE220 as the default printer.	1. Refer the customer to the PE220 User Guide.
2. Secure more space of the hard disk.	2. Not working with the message 'insufficient printer memory' means hard disk space problem rather than the RAM problem. Ask the customer to provide more space for the hard disk, using the disk utilities program.
3. Printing error occurs even if there is enough space in the hard disk.	3. The connection of the cable and printer port is not correct. Check if the connection is correct. Ask the customer to check the BIOS of the PC to ensure that there are no IRQ conflicts and to check that the input/output range is 0378.
4. Check the parallel-port-related items in the BIOS	4. Ask the customer to select ECP or SPP. SPP (Normal), ECP, and EPP modes (increase printing speed). SPP normal mode supports 8-bit data transfer. ECP mode supports 12-bit data transfer.
5. Reboot the system to print.	5. If the regular font is not printing, the cable or the print driver may be defective. Turn the PC and machine off, and reboot the system to print again. If not solved, double-click the printer in my computer. If the regular fonts are not printing again, the cable must be defective. Replace the cable with new one.

13 Abnormal Printing RAP

Description

The machine is not working correctly even when there is no problem with the printer cable. If the machine will not work at all or the strange fonts are repeated, the printer driver may be defective or wrong setup in the BIOS Setup.

Check and Cause	Solution
1. Set up the parallel port in the BIOS.	1. Ask the customer to select SPP (Normal) or ECP LPT Port in the BIOS.
2. Printer Driver Error.	2. Uninstall the driver. Re-install the latest driver. Refer to Xerox.com
3. Error message from insufficient memory. (The printing job sometimes stops or due to insufficient virtual memory, but it actually comes from the insufficient space of the hard disk.)	3. Ask the customer to delete the unnecessary files to secure enough space of the hard disk and start printing job again.

14 SPOOL Error RAP

Description

Insufficient disk space to spool the document.

Check and Cause	Solution
1. Insufficient space of the hard disk in the directory assigned for the basic spool.	1. Ask the customer to delete the unnecessary files to provide more space to start printing job.
2. If the previous printing error not solved.	2. Inform the customer. There may be files from previous failed print jobs on the hard disk with the name in the form '*.jnl'. Delete these files and Reboot Windows to restart the machine.
3. There may be conflict with other drivers or programs.	3. Ask the customer to shut down all other programs except the current one, if possible.
4. When an application program or the printer driver is damaged.	4. Uninstall the print driver. Re-install the latest driver. Refer to Xerox.com.
5. When some files related to OS are damaged or virus infected.	5. After rebooting the computer ask the customer to check for viruses, restore the damaged files and reinstall the application program which is not working properly.
6. Insufficient memory.	6. Ask the customer to add memory to the PC.
7. Check the print queue.	7. Ask the customer to manage the print queue.

How to delete the data in the spool manager.

In the spool manager, the installed drivers and the list of the documents waiting to be printed are shown.

Select the document to be deleted and check delete in the menu.

If the job you are deleting is the current job, when you delete the job data that has already been transferred to the machine's memory will still be printed. If there is a problem with the machine (out of toner, off-line, out of paper etc.) the job may take a long time to delete as it must wait for a time out.

15 Fax & Phone Problems RAP

15A No Dial Tone

Description

There is no dial tone when the Manual Dial key is pressed.

Check and Cause	Solution
1. Check that the telephone line cord supplied with the set is connected to TEL LINE correctly.	1. If the telephone cord is OK but there is no dial tone, try plugging a normal telephone into the wall socket. If this is OK then replace the LIU PBA, PL 1 .
2. Listen for a CLICK sound when the Manual Dial key is pressed. Note: Key sound must be set to "on" in GP 3 , User Mode.	2. If you cannot hear the Manual Dial CLICK sound, the OPE Assembly may be defective. Replace the OPE Assembly, PL 5 .
3. Check the connection of the HARNESS between the LIU and the Main Board.	3. Check the Speaker connection and the harness between the LIU and the Main PBA, replace as necessary, PL 1 .
4. Check that the SPEAKER is connected correctly.	4. Use Tech mode / Modem Test, GP 4 , to check that the speaker and amplifier are working. Replace the Main PBA, PL 1 .

15B Defective MF DIAL

Description

The MF DIAL is not functioning.

Check and Cause	Solution
1. Check that the telephone line cord supplied with the set is connected to TEL LINE correctly.	1. If the telephone cord is OK but there is no dial tone, try plugging a normal telephone into the wall socket. If this is OK then replace the LIU PBA, PL 1 .
2. Listen for a CLICK sound when the KEY is pressed. Note: Key sound must be set to "on" in GP 3 , User Mode.	2. If you cannot hear the Manual Dial CLICK sound, the OPE Assembly may be defective. Replace the OPE Assembly, PL 5 .
3. Check the connection of the HARNESS between the LIU and the Main PBA.	3. Check the Speaker connection and the harness between the LIU and the Main PBA, replace as necessary, PL 1 .
4. Check that the SPEAKER is connected correctly.	4. Use Tech mode / Modem Test, GP 4 , to check that the speaker and amplifier are working. Replace the LIU and Main Board in sequence Note: Product supports MF DIAL type only.

15C Defective FAX SEND/RECEIVE

Description

FAX SEND/RECEIVE is not functioning.

Check and Cause	Solution
1. Check that you can hear a dial tone by pressing Manual Dial.	1. If MODEM testing is normal and there is no dial tone, replace the LIU PBA, PL 1 .
2. Check that you can hear a RECEIVE tone when MODEM testing in TECH Mode, GP 4 .	2. If testing the MODEM shows a fault replace the Main PBA, PL 1 .

15D Defective FAX SEND

Description

RECEIVE is functioning, but FAX SEND is not functioning or received data is corrupt.

Check and Cause	Solution
1. Check for NOISE on the line. Press Manual Dial and listen.	1. If the line is noisy, inform the customer.
2. Check that the destination fax machine can receive forwarded faxes by using a different sending fax machine (preferably from the same wall socket).	2. Replace LIU PBA, PL 1 .
3. Check the cable between the set and the wall socket for damage.	3. Replace the line cord, PL 1 .

15E Defective FAX RECEIVE (1)

Description

FAX SEND is functioning, but RECEIVE is not functioning or the received data is corrupt.

Check and Cause	Solution
1. Check for NOISE on the line. Press Manual Dial and listen.	1. If the line is noisy, inform the customer.
2. Use a different fax machine to receive from the same sender (if possible on the same wall socket).	2. Replace the LIU PBA, PL 1 .

15F Defective FAX RECEIVE (2)

Description

Received data is corrupted.

Check and Cause	Solution
1. Check for NOISE on the line. Press Manual Dial and listen.	1. If you can hear a noisy line when using Manual Dial, replace or repair the telephone line.
2. Ask sender to send to another fax machine (if possible connected to the same wall socket)	2. Replace LIU or main PBA , PL 1 .

15G Defective FAX RECEIVE (3)

Description

The phone is ringing continuously, but the machine does not answer the call.

Check and Cause	Solution
1. Check that the RECEIVE Mode is set to FAX MODE.	1. If the fault persists even when the RECEIVE Mode is changed to FAX MODE then replace the LIU and the Main PBA, PL 1 .

15H Defective FAX RECEIVE (4)

Description

Received data is reduced by more than 50% in the printing.

Check and Cause	Solution
Check the FAX status of the forwarding side.	This is a problem with the sending fax machine. Inform the customer.

15I Defective Automatic Receiving

Description

The automatic receiving function is not working.

Check and Cause	Solution
1. Check that the RECEIVE Mode is set to FAX MODE.	1. If the RECEIVE Mode is set to the TEL MODE, reset it to the FAX MODE.
	2. Even after the RECEIVE Mode is changed to the FAX Mode, the problem persists then try to replace the LIU and the Main PBA, PL 1 .

16 Abnormal Noise RAP

Description

There is noise from the ADF when copying.

Check and Cause	Solution
1. Check the Scanner Motor, gearbox and rollers.	1. Check for correct assembly of gears and motor. Ensure no parts are damaged and there are no foreign objects in the mechanism or scan path. Replace any worn parts, PL 2 .
2. Check the Motor Driver on Driver PBA.	2. Replace the Main PBA, PL 1 and ADF PBA, PL 2 .

17 Scanning RAP

17A PC Scanning Problems

Description

Unable to scan using a PC.

Check and Cause	Solution
1. Check the Cable (USB or Parallel) is properly connected and that the machine can print correctly.	1. Reconnect the PC and machine, replace any faulty cables. If using a parallel cable, check that the parallel port is properly configured. Ask the customer to check the BIOS of the PC to ensure that there are no IRQ conflicts and to check that the input/output range is 0378.
2. Check that the driver is installed properly.	2. If printing is OK check that the Scan driver is also installed (Refer to User's Manual.)
3. Check that the copy function operates normally.	3. If the copy function works, replace the Main PBA, PL1 . If the copy function does not work, replace the CIS, PL4 and try again.

17B Poor Quality of PC Scanned images

Description

Poor quality of scanned to PC images.

Check and Cause	Solution
1. Use TECH mode, GP4 , to carry out a shading test and examine the waveform print-out.	1. If the CIS waveform form is abnormal replace the CIS, PL4 .
2. Check if the resolution is set too low in PC Scan options. (Refer to the User Manual.)	2. Teach the user about scanner resolution – refer to the User Guide.

18 Print Cartridge Problems RAP

This section explains messages on the LCD that are related to the data stored in the EEPROM in the print cartridge.

Toner Low

- Explanation: The amount of toner remaining is less than 10%. The print cartridge is almost empty or at end of life.
- Solution: Replace the print cartridge, [PL 1](#).

Toner Empty

- Explanation: The print cartridge is empty
- Solution: Replace the print cartridge, [PL 1](#).

Drum Warning

- Explanation: This message appears when the OPC drum is nearing the end of its life (14,000 pages). This means that the life of the mechanical parts in the print cartridge has expired (this is not an indication of toner remaining).
- Solution: After printing about 15,000 pages, in a worst case scenario, the waste toner collector might overflow and it may cause the system to fail. Also after 15,000 pages the OPC drum surface will be becoming worn and print quality will degrade, print images will become misty. It is therefore necessary to replace the print cartridge even though there may be toner left in it. When this message occurs there are approximately 1,000 pages left.

Replace Drum

- Explanation: The print cartridge mechanical life is expired.
- Solution: Replace the print cartridge, [PL 1](#).

19 Software Problems RAP

19A The machine is not working (1)

Description

While Power turned on, the machine is not working in print mode.

Check and Cause	Solution
1. Ensure that the customer knows how to install the correct printer driver and to select the PE220 as the default printer.	1. Refer the customer to the PE220 User Guide.
2. Perform the pattern test, GP 4 .	2. If the test print works that means there are no problems in the machine itself. If the test printing does not work that means the machine is faulty and the problem is not due to computer software or driver settings.
3. Check that the PC and the machine are properly connected and that the print cartridge is installed correctly.	3. Replace the printer cable. If the problem is not solved even after the cable is replaced, check the amount of the remaining toner. (refer to print Cartridge Service)
4. Printing is not working in Windows.	4. Check if the connection between PC and printer port is correct. Uninstall the driver, then re-install new drivers. Refer to Xerox.com. Ask the customer to check the BIOS of the PC to ensure that there are no IRQ conflicts and to check that the input/output range is 0378.
5. Check that the printer cable is directly connected to the machine.	5. If you have other devices that need to share the printer port try temporarily disconnecting these devices and perhaps even uninstalling their drivers) to ensure the machine works by itself. If you are using a USB hub try connecting directly to the back of the PC instead.

19B The machine is not working (2)

Description

After receiving the print command there is no response at all or print speed is low due to wrong setup of the environment rather than malfunction of the machine itself.

Check and Cause	Solution
1. Ensure that the customer knows how to install the correct printer driver and to select the PE220 as the default printer.	1. Refer the customer to the PE220 User Guide.
2. Ensure you have sufficient free hard disk space for the temporary work files created during printing.	2. The message 'insufficient printer memory' means there is a hard disk space problem on the PC, rather than a printer RAM problem. Inform the customer.
3. Printing error occurs even if there is enough space in the hard disk.	3. The connection of the cable and printer port is not correct. Check that the cable is properly connected. Ask the customer to check the BIOS of the PC to ensure that there are no IRQ conflicts and to check that the input/output range is 0378.
4. Check the parallel-port-related items in the BIOS.	4. For the printer port, select ECP. SPP and normal modes support 8-bit data transfer. ECP mode supports 12-bit data transfer.
5. Reboot the system to print.	5. If the regular font is not printing, the cable or the printer driver may be defective. Turn the PC and machine off, and reboot the system to print again. If not solved, double-click the printer in my computer. If the regular fonts are not printed this time the cable must be defective so replace the cable with new one.

19C Abnormal Printing

Description

Printing does not work – even after replacing the cable
Machine does not work at all or strange fonts are printed.

Check and Cause	Solution
1. Set up the parallel port in the BIOS.	1. Ask the customer to ensure that ECP (best) or SPP is selected in the BIOS setup.
2. Printer Driver Error.	2. Ensure that the correct driver is loaded. Use the driver supplied on the CD or downloaded from the Xerox.com. DO NOT use the Microsoft driver supplied with the Windows operating system. If the machine is a GDI printer ensure that ALL OTHER GDI drivers are un-installed as Windows allows only 1 type of driver to be loaded.
3. Error message “insufficient memory”. (The printing job sometimes stops due to insufficient virtual memory, this is caused by insufficient space on the PC hard disk.)	3. Inform the customer.

Page intentionally blank

3. Image Quality

IQ 1 Vertical Black Line and Band	3-3
IQ 2 Vertical White Line	3-4
IQ 3 Horizontal Black Band	3-5
IQ 4 Black/White Spot	3-6
IQ 5 Light Image	3-7
IQ 6 Dark Image or Black Image	3-8
IQ 7 Uneven Density	3-9
IQ 8 Background	3-10
IQ 9 Ghost (1)	3-11
IQ 10 Ghost (2)	3-11
IQ 11 Ghost (3)	3-12
IQ 12 Ghost (4)	3-12
IQ 13 Contamination on the Face of Page	3-13
IQ 14 Contamination on Back of Page	3-13
IQ 15 Blank Page Print out (1)	3-14
IQ 16 Blank Page Print out (2)	3-14
IQ 17 Misregistration	3-15
IQ 18 Printed Vertical Lines Not Straight	3-16
IQ 19 Blurred Image	3-17

Page intentionally blank

IQ 1 Vertical Black Line and Band

Description

Straight thin black vertical line occurs in the printing.

Dark black vertical band occur in the printing.

	Check and Cause	Solution
	1. Dirty CVT Glass.	1. Clean the CVT Glass.
	2. Damaged develop roller in the Developer. Deformed Doctor-blade or cleaning-blade.	2. If causes 1 and 2 occur in the print cartridge. Install a new print cartridge, PL 1 .
	3. Scratched surface of the discharge roller in the print cartridge.	3. Install a new print cartridge, PL 1 .
	4. Partly depression or deformation on the surface of the transfer roller.	4. Replace the transfer roller, PL 6 .

IQ 2 Vertical White Line

Description

White vertical voids in the image.

	Check and Cause	Solution
	1. Foreign matter stuck onto the window of internal lenses of LSU mirror.	1. Clean the LSU window with recommended cleaner (IPA). Clean the window with a clean cotton swab. If necessary, install a new LSU, PL 1 .
	2. Foreign matter or toner particles between the developer roller and blade. (In case the life of the developer has been expired, white lines or light image occur in front of the image.)	2. Install new print cartridge, PL 1 .
	3. If the fuser is defective, voids occur periodically at the top of a black image.	3. Open the front cover. Clean the stripper fingers. Install parts as necessary, PL 7 . If the problems are not solved, replace the print cartridge, PL 1 .

IQ 3 Horizontal Black Band

Description

Dark or blurry horizontal stripes on print.

	Check and Cause	Solution
	<p>1. Bad contacts of the voltage terminals to developer.</p>	<p>1. Clean each voltage terminal of the Charge, Supply, Develop and Transfer roller. (remove the toner particles and paper particles)</p>
	<p>2. The rollers used in the image development process may be contaminated.</p> <p>OPC Drum = 75.5mm Charge Roller = 37.7mm Supply Roller = 47.5mm Develop Roller = 35.2mm Transfer Roller = 46.2mm Heat Roller = 63.9mm Pressure Roller = 75.4mm</p>	<p>2. Clean the component that corresponds to the repeat interval of the defect.</p> <p>If the defect persists, install a new print cartridge, PL 1 or fuser, PL 1 based on the interval of the black band.</p>

IQ 4 Black/White Spot

Description

Dark or blurry black spots on the print.

White spots occur on the print.

	Check and Cause	Solution
	<p>1. If dark or blurry black spots occur periodically, the rollers in the Developer may be contaminated with foreign matter or paper particles. (Charge roller: 37.7 mm interval OPC drum: 75.5 mm interval)</p>	<p>1. Run OPC cleaning Mode Print and run the Self-test 2 or 3 times. Refer to GP 3. If necessary, install a new print cartridge, PL 1.</p>
	<p>2. If faded areas or voids occur in a black image at intervals of 75.5 mm, or black spots occur elsewhere, the OPC drum surface is damaged.</p>	<p>2. In case of 75.5 mm interval unremovable in 1, cleanly remove foreign substances stuck on the OPC location equivalent to black spots and white spots with a clean cloth.</p>
	<p>3. If a black image is partially broken, the transfer voltage is abnormal or the transfer roller's life has expired. (Approximately 50,000 sheets)</p>	<p>3. If the roller's life is expired, replace it. Install a new transfer roller, PL 6.</p> <p>4. In case of 37.7 mm interval unremovable in 1, take measures as to replace the print cartridge and try to print out.</p> <p>5. Clean the inside of the machine.</p>

IQ 5 Light Image

Description

The printed image is light, with no ghost.

	Check and Cause	Solution
	1. Develop roller is contaminated when the print cartridge is almost consumed.	1. Install a new print cartridge, PL 1 .
	2. Ambient temperature is below than 10°C.	2. Wait 30 minutes after printer is powered on before you start printing.
	3. Check shading profile.	3. Redo shading profile in the Tech mode.
	4. Bad contact caused by the toner contamination between the high voltage terminal in the HVPS and the one in the set.	4. Clean the contaminated area.
	5. Abnormal output from the HVPS can be caused by contamination	5. If necessary, install a new HVPS, PL 1 .

IQ 6 Dark Image or Black Image

Description

The printed image is dark.

	Check and Cause	Solution
	1. Identify if the problem is caused by the Scanner or the LSU / Xerographics.	1. Perform pattern test, GP 4 . If pattern is good, check the scanner. If pattern is bad, check the LSU / Xerographics.
	2. No charge voltage.	2. Clean the high voltage charge terminal.
	3. Charge voltage is not turned on due to bad contact between the power supply in the side of the Developer and charge terminal of HVPS.	3. Check the connections between the main PBA and HVPS. If necessary install a new main PBA or HVPS, PL 1 .
	4. Check for CIS problem on the Main PBA.	4. Check the CIS FFC Cable is properly connected.
	5. Check shading profile.	5. Perform the shading test, GP 4 .

IQ 7 Uneven Density

Description

Print density is uneven.

	Check and Cause	Solution
	1. The pressure force on the left and right springs of the transfer roller is not even, the springs are damaged, the transfer roller is improperly installed, or the transfer roller bushing or holder is damaged.	1. Install parts as necessary, PL 6 .
	2. The toner level is not even on the developer roller.	2. Install a new print cartridge, PL 1 .
	3. Low toner in print cartridge.	3. Shake the print cartridge. If Image Quality is still poor, install a new print cartridge, PL 1 .

IQ 8 Background

Description

Light dark background on the print.

	Check and Cause	Solution
	1. Has the customer been making a lot of prints at less than 2% area coverage? Note: <i>The print cartridge is basically designed to print 3,000 sheets with 5% image.</i>	1. Inform the customer that low area coverage will cause background problems.
	2. Is recycled paper being used?	2. Image quality is not guaranteed if recycle paper is used.
	3. Has the life span of the developer ended?	3. Install a new print cartridge, PL 1 .
	4. Is the movement (Up and Down) of the transfer roller smooth?	4. Clean the bushings on the transfer roller, PL 6 .
	5. The HVPS maybe defective.	5. If the problem is still present, install a new print cartridge, PL 1 , or HVPS as necessary, PL 1 .

IQ 9 Ghost (1)

Description

Ghost occurs at 75.5 mm intervals of the OPC drum on the print.

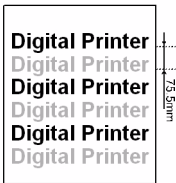
	Check and Cause	Solution
	1. Bad contacts caused by contamination from toner particles between high voltage terminal in the main body and the electrode of the Developer.	1. Clean the terminals.
	2. The life of developer is expired.	2. Install a new print cartridge, PL 1 .
	3. Transfer roller lifetime (50.000 sheets) has expired.	3. Check the transfer roller lifetime and if necessary install a new transfer roller, PL 6 .
	4. Abnormal low temperature (below 10°C).	4. Wait about 30 minutes after power on before using the machine.
	5. Bad contacts caused by contamination from toner particles between high voltage terminal in the main body and the one in the HVPS board.	5. Install a new main PBA or HVPS, PL 1 .

IQ 10 Ghost (2)

Description

Ghost occurs at 75.5 mm intervals of the OPC drum on the print.

(When printing on card stock or transparencies using manual feeder)

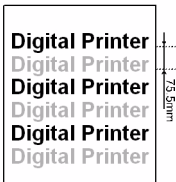
	Check and Cause	Solution
	When printing on card stock thicker than normal paper or transparencies such as OHP, higher transfer voltage is required.	Inform the customer to Select 'Thick Mode' on paper type menu from the software application and after using returning to the original mode is recommended.

IQ 11 Ghost (3)

Description

White ghost occurs in the black image printing at 47.5mm intervals.

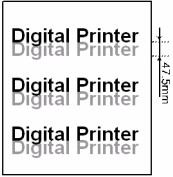
	Check and Cause	Solution
	1. The life of the developer may be expired.	1. Install a new print cartridge, PL 1 .
	2. Possible abnormal voltage and bad contact of the terminal of the supply roller in the print cartridge.	2. Install a new print cartridge, PL 1 .

IQ 12 Ghost (4)

Description

Ghost occurs at 47.5mm(or 63.9mm) intervals.

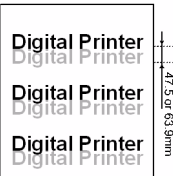
	Check and Cause	Solution
	1. The temperature of the fuser is too high because the thermistor is contaminated.	<p>CAUTION <i>Take care not to bend or break the thermistor.</i></p> <p>1. Clean the heat roll, pressure roll and thermistor, PL 7. If necessary install a new fuser, PL 1.</p>

IQ 13 Contamination on the Face of Page

Description

The background on the face of the printed page is contaminated.

	Check and Cause	Solution
	1. Toner leakage due to improperly sealed developer.	1. Install a new print cartridge, PL 1 .
	2. The transfer roller maybe contaminated.	2. Run DRUM Cleaning Mode, GP 3 . Make 2 or 3 prints
	3. The fuser roll may be contaminated	3. Inspect and clean the fuser roll, PL 7 . Replace if necessary.

IQ 14 Contamination on Back of Page

Description

The back of the page is contaminated at 47 mm intervals.

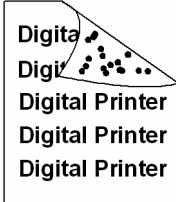
	Check and Cause	Solution
	1. Transfer roller is contaminated.	1. Run DRUM Cleaning Mode, GP 3 . Make 2 or 3 prints 2. Replace the transfer roller, PL 6 .
	2. Pressure roller is contaminated.	CAUTION <i>Take care not to bend or break the thermistor.</i> 3. Clean the heat roll, pressure roll and thermistor. If necessary install a new fuser, PL 1 .

IQ 15 Blank Page Print out (1)

Description

Blank page is printed.

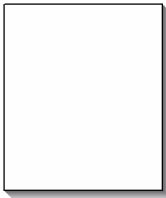
	Check and Cause	Solution
	1. Bad ground contacts in OPC and/or developer.	1. Remove contamination from the terminals of the developer and the OPC unit.
	2. Check the Scanner Cover is properly closed.	2. Room light can pass through a thin original.
	3. Check shading profile.	3. Redo shading profile in the tech mode, refer to GP 4 .
	4. Check white/black reference voltage on Main PBA.	4. Replace the Main PBA, PL 1 .

IQ 16 Blank Page Print out (2)

Description

Blank page is printed.

One or several blank pages are printed.

When the machine turns on, several blank pages print.

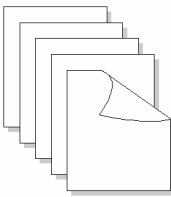
	Check and Cause	Solution
	1. Bad ground contacts in OPC and/or developer.	1. Remove contamination from the terminals of the developer.
	2. Abnormal solenoid.	2. Perform the engine self test using Engine Test Mode to check the Solenoid, GP 7 . 3. Turn the power off, then on. Resend the job. 4. Install a new Main PBA, PL 1 .

IQ 17 Misregistration

Description

Printing begins at wrong position on the paper.

Check and Cause	Solution
Wrong sense time caused by defective feed sensor actuator.	Replace the defective actuator, PL 6 .

IQ 18 Printed Vertical Lines Not Straight

Description

When printing, vertical lines are not straight.

Check and Cause	Solution
1. Check stability of 24V supply to LSU.	1. 24V stable - Replace LSU, PL 1 . 24V unstable replace SMPS, PL 1 . If the problem persists replace the main PBA, PL 1 .

IQ 19 Blurred Image

Description

Image is blurred.

Check and Cause	Solution
1. Check the gap between original and platen glass.	1. A gap of more than 0.5 mm can cause a blurred image. Ensure rollers and cover close correctly. Replace as necessary, PL 1 .

Page intentionally blank

4. Repairs/Adjustments

REP 1 MP Tray	4-3
REP 2 Pick Up Roller	4-4
REP 3 Front Cover	4-4
REP 4 Cassette Tray	4-5
REP 5 Rear Cover	4-5
REP 6 Right Cover	4-6
REP 7 Left Cover	4-7
REP 8 Scan Assembly	4-8
REP 9 ADF Housing	4-9
REP 10 OPE Unit	4-11
REP 11 Platen Housing	4-12
REP 12 Middle Cover	4-14
REP 13 HVPS	4-15
REP 14 Main PBA	4-15
REP 15 RX Drive	4-16
REP 16 Fuser	4-17
REP 17 Engine Shield (LIU PBA, SMPS)	4-21
REP 18 LSU	4-22
REP 19 Paper Path Frame	4-23

Page intentionally blank

REP 1 MP Tray

1. Open the Front Cover.

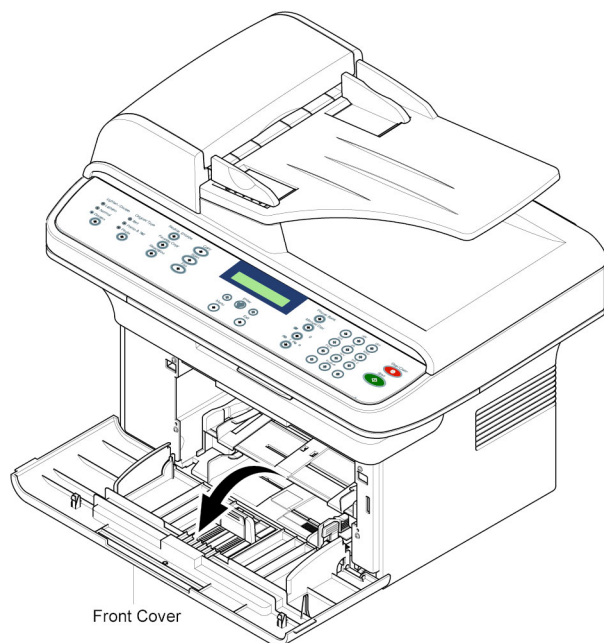

Figure 1

2. Remove the Print Cartridge.

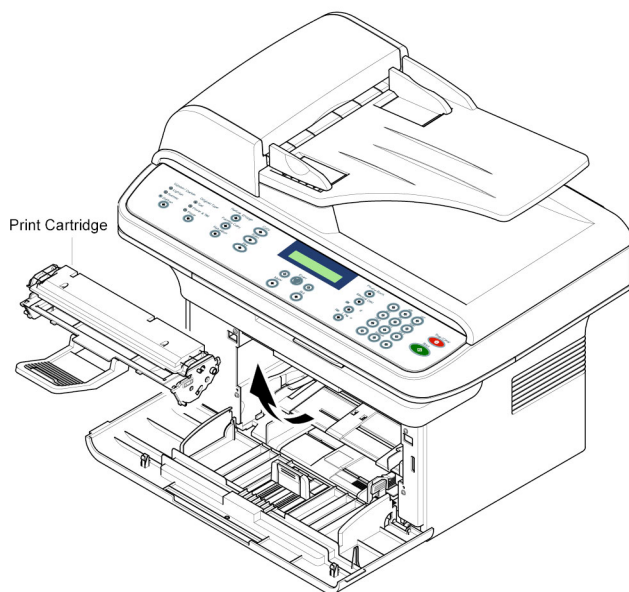

Figure 2

3. Hold the MP Tray and pull it in the direction of the arrow.

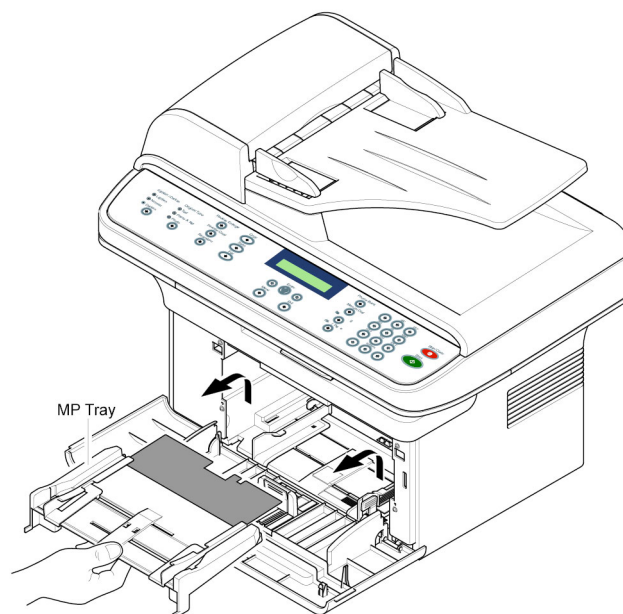

Figure 3

REP 2 Pick Up Roller

1. Before you remove the Pick Up Roller, you should remove:
 - MP Tray (Refer to [REP 1](#))
2. To exchange the Pick Up Sponge, pull apart Pick Up Housing U while pressing the hooks on both sides of Pick Up Housing B.

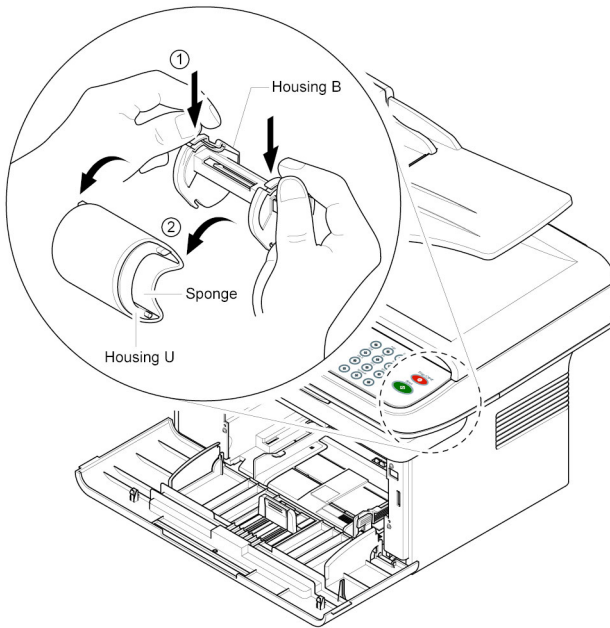
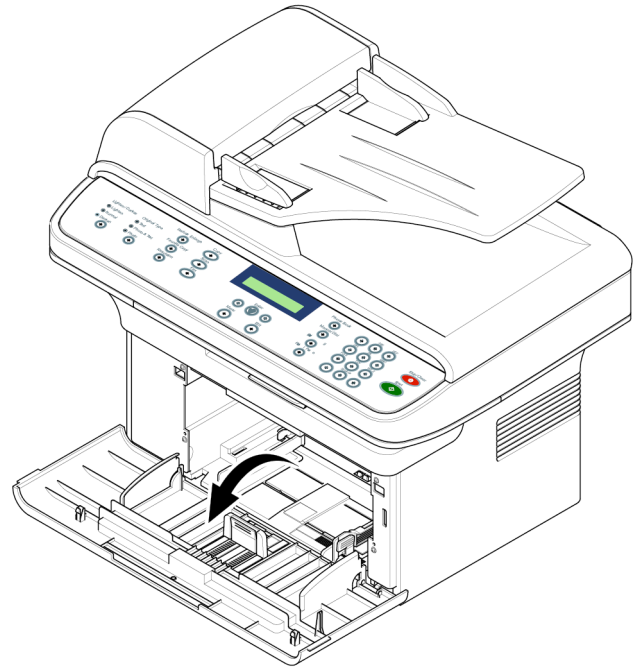

Figure 1

REP 3 Front Cover

1. Open the Front Cover.



2. To remove the Front Cover, carefully pull the part below the right side of the Front Cover in the direction of the arrow (left).

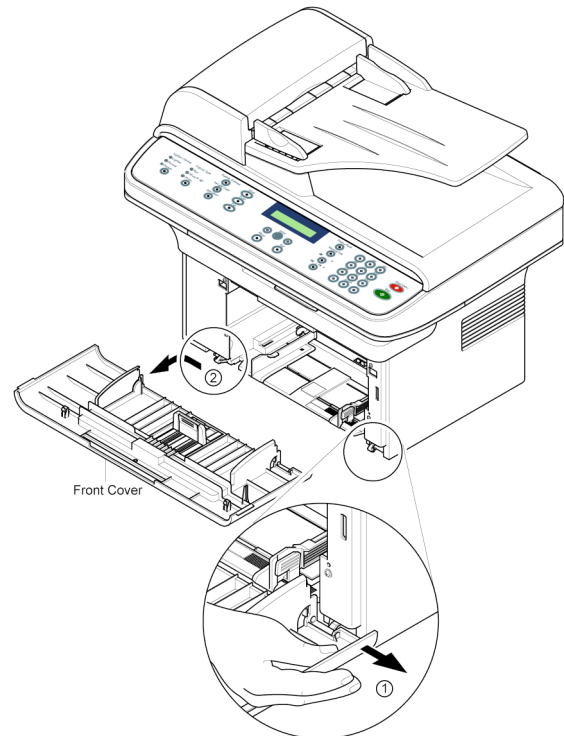

Figure 2

REP 4 Cassette Tray

1. Open the Cassette Tray.



Figure 1

2. To remove the Cassette Tray, carefully lift the knob in the direction of the arrow while holding the Set (left).

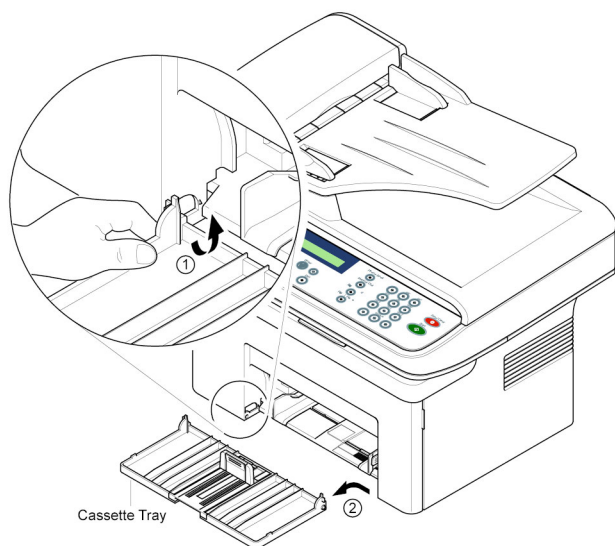

Figure 2

REP 5 Rear Cover

1. Remove four screws securing the Rear Cover.

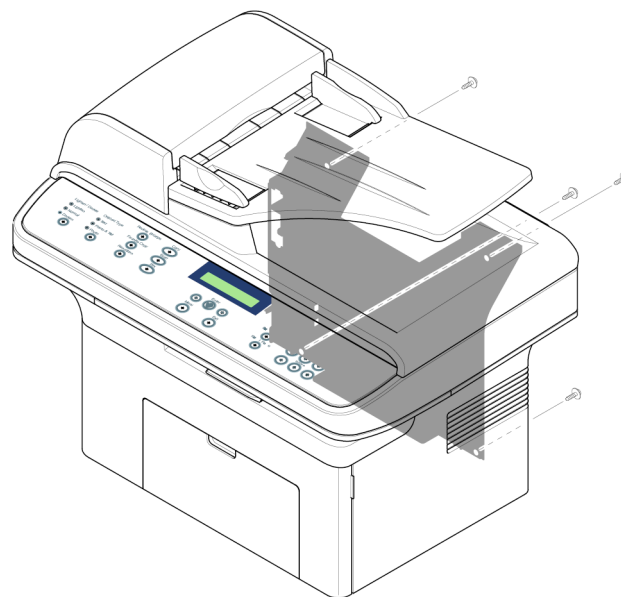

Figure 1

2. Open the Jam Cover.

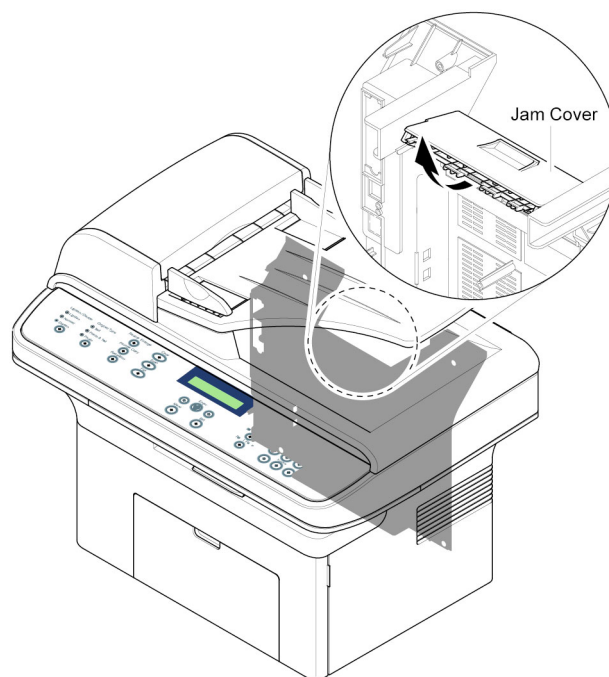

Figure 2

3. To remove the Rear cover, make sure the right Power Switch does not get jammed to the Rear Cover.

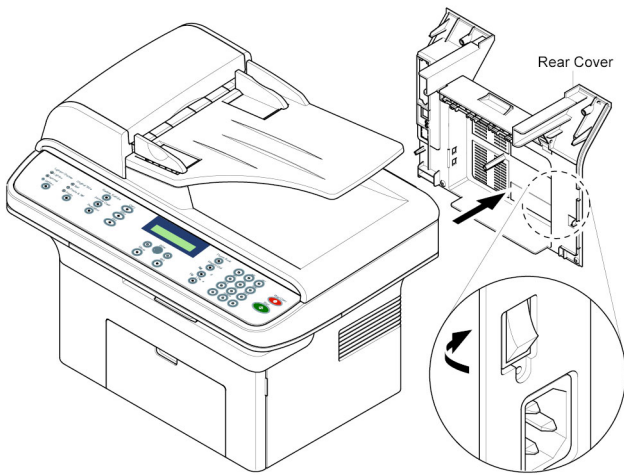

Figure 3

4. If necessary, remove the Jam Cover in the direction of arrow.

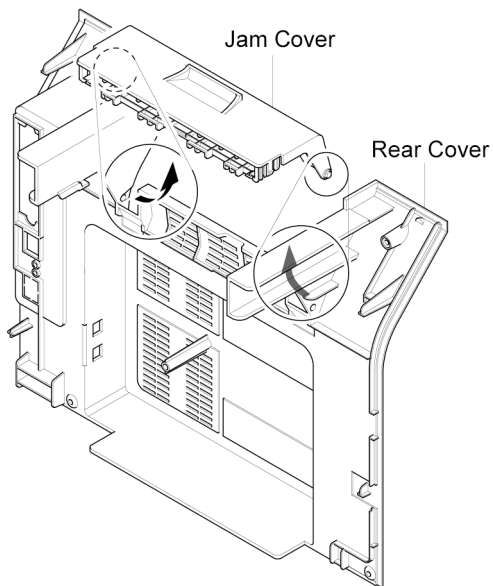

Figure 4

REP 6 Right Cover

1. Before you remove the Right Cover, you should remove:
 - Front Cover (Refer to [REP 3](#))
 - Rear Cover (Refer to [REP 5](#))
2. Remove the screw securing the Right Cover.

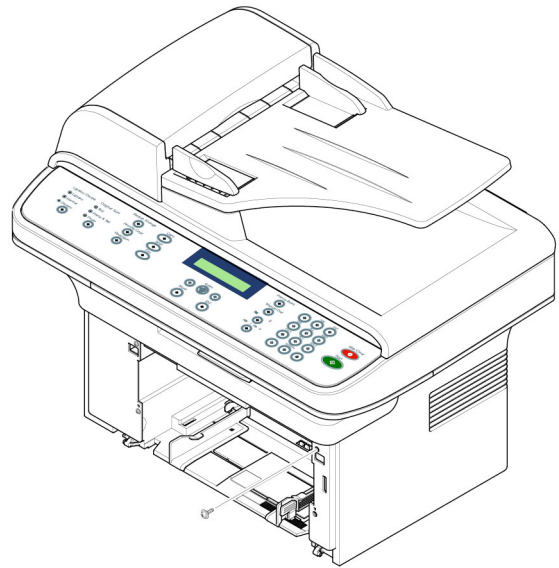

Figure 1

3. Apply light pressure to the back of the Right Cover and pull it to the right side in the direction of the arrow.

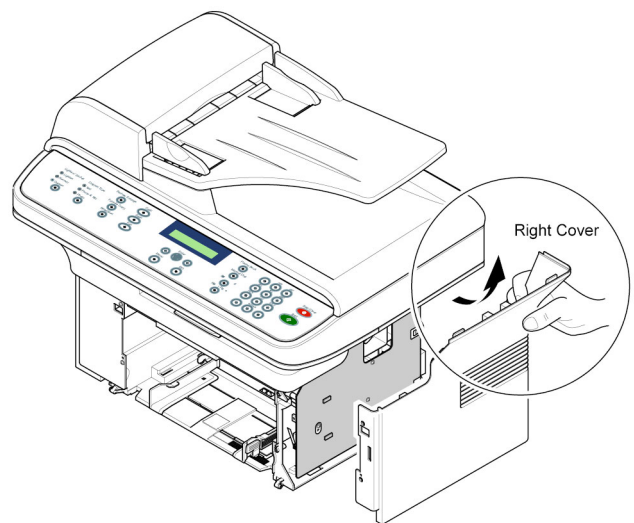

Figure 2

REP 7 Left Cover

1. Before you remove the Left Cover, you should remove:
 - Front Cover (Refer to [REP 3](#))
 - Rear Cover (Refer to [REP 5](#))
2. Remove the screw securing the Left Cover.

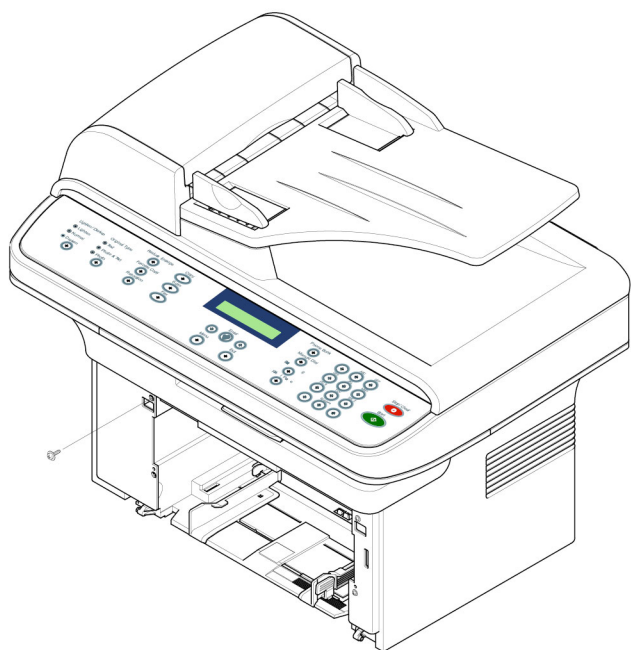

Figure 1

3. Apply light pressure to the back of the Left Cover and pull it to the left side in the direction of the arrow.

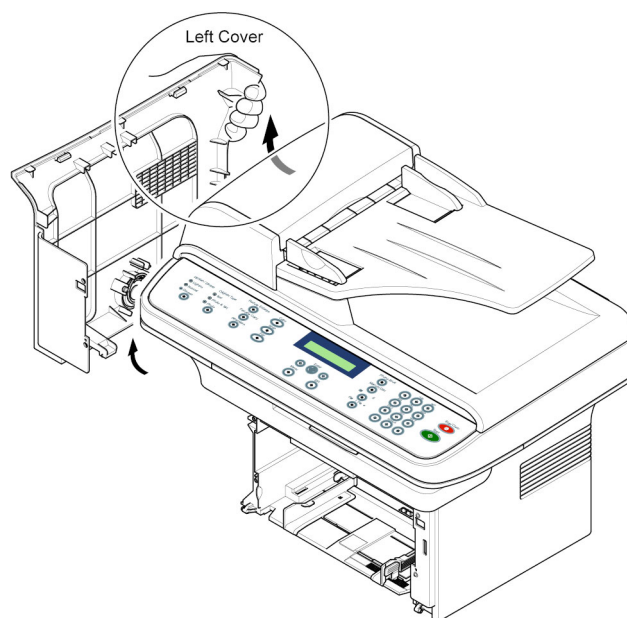

Figure 2

4. Unplug the Speaker Connector from the Main PBA.

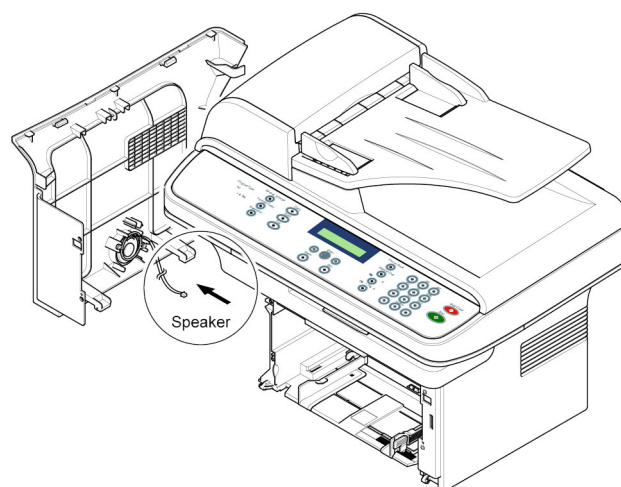

Figure 3

5. If necessary, remove the two screws securing the Speaker.

REP 8 Scan Assembly

1. Before you remove the Scan Assembly, you should remove:
 - Rear Cover (Refer to [REP 5](#))
 - Right Cover (Refer to [REP 6](#))
 - Left Cover (Refer to [REP 7](#))
2. Remove two screws from the Middle Cover and remove the screw securing the Ground Cable.

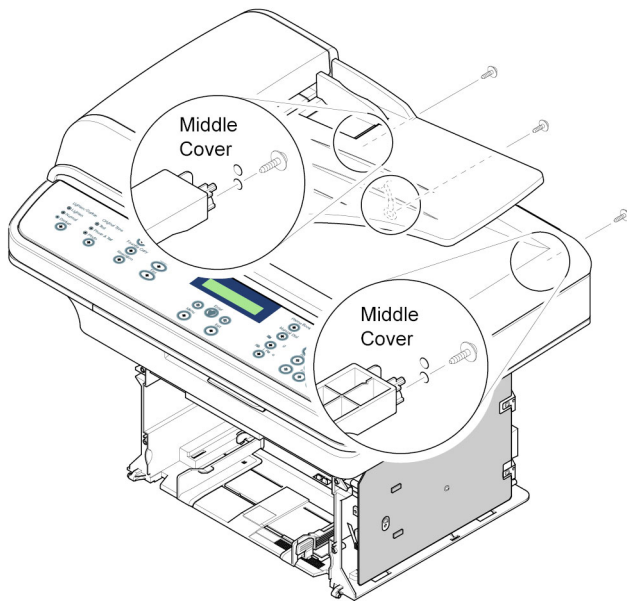

Figure 1

3. Unplug the three Connectors (ADF, Scan Motor, OPE) and Flat Cable-CIS.

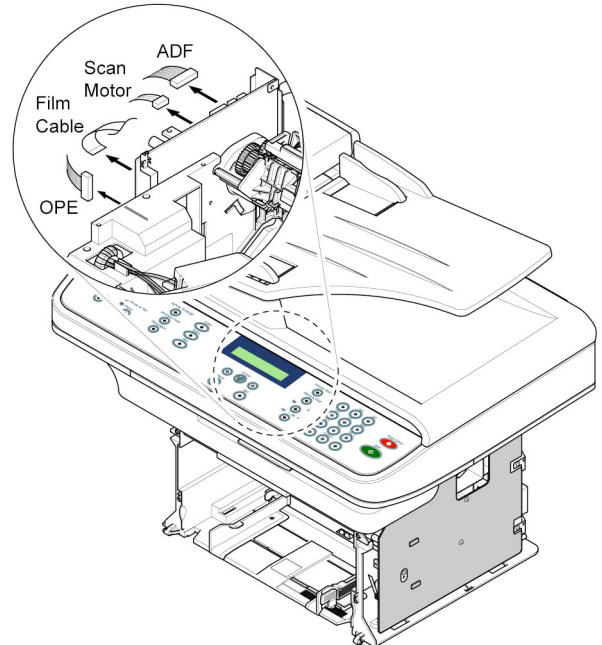

Figure 2

4. Release the Scan Assembly in the direction of the arrow.

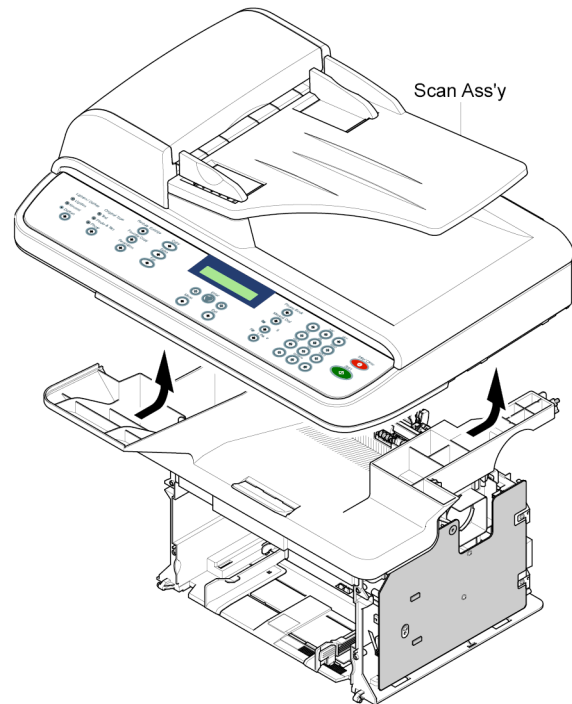

Figure 3

REP 9 ADF Housing

1. Before you remove the ADF Housing, you should remove:
 - Scan Assembly (Refer to [REP 8](#))
2. Open the ADF Housing and insert a flat-blade screwdriver into the slot and remove the Cap-Hinge from the Platen Housing and ADF Housing.

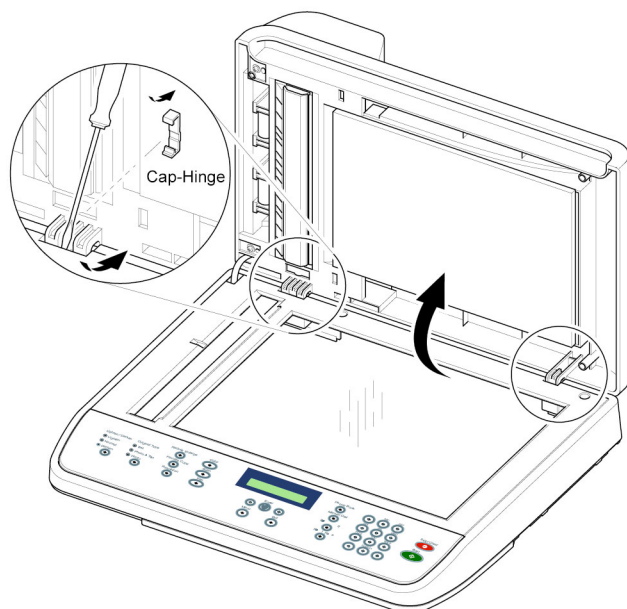

Figure 1

3. Remove the ADF Housing from the Platen Housing, while carefully releasing the ADF Motor Harness and ground wire from the Platen Housing.

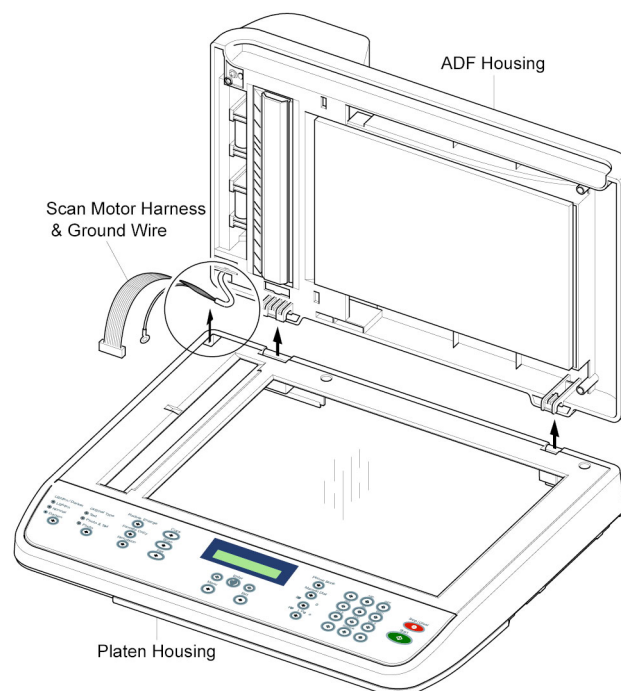

Figure 2

4. Remove two screws securing the ADF Assembly. Carefully release the ADF Motor Harness and ground wire from the Platen Cover..

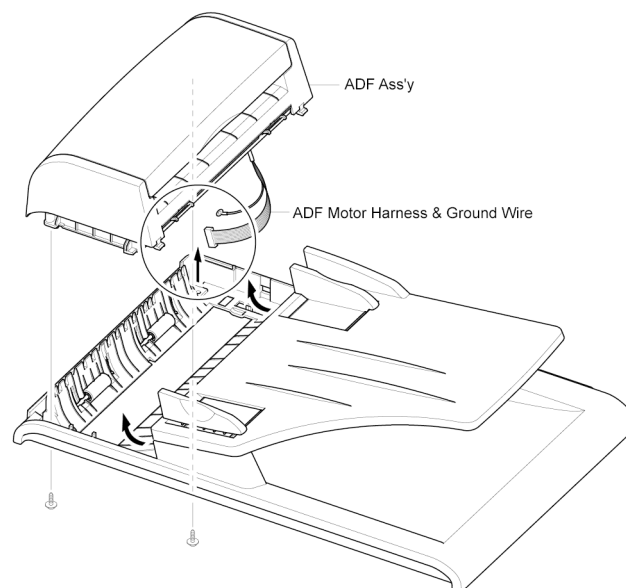

Figure 3

5. If necessary, remove two screws securing the TX Stacker Assembly.

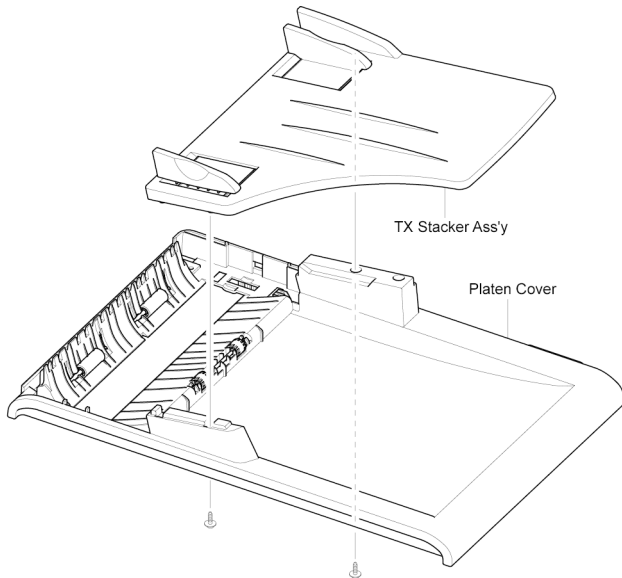

Figure 4

6. Open the Open Cover and remove the Open Cover in the direction of the arrow.

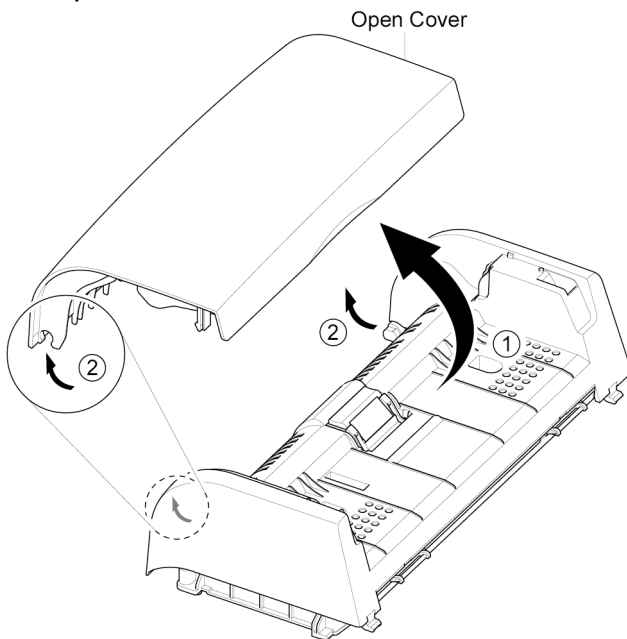

Figure 5

7. Pull and rotate the Bushing until it reaches the slot, then lift the Pick Up Unit.

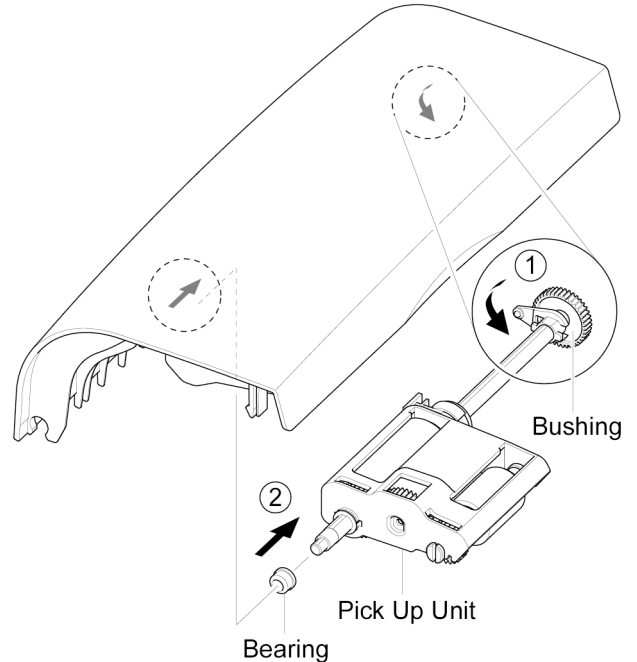

Figure 6

8. Remove two screws securing the ADF Upper and insert a flat-blade screwdriver in to the slot and remove the ADF Upper.

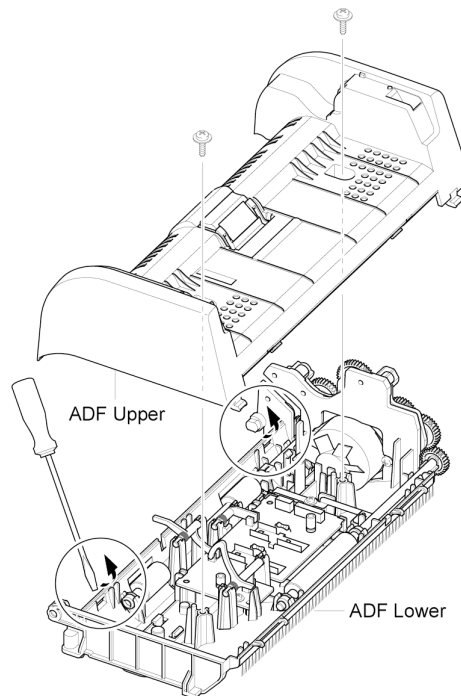

Figure 7

- Unplug the Connector from the ADF PBA and remove four screws securing the ADF Motor Housing and remove it in the direction of the arrow.

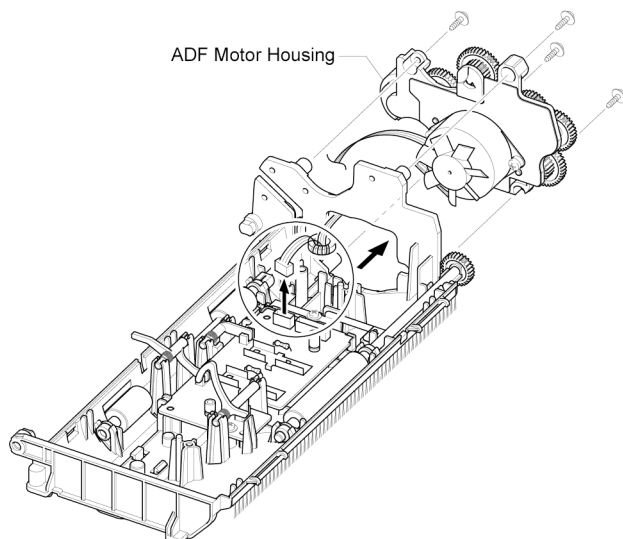

Figure 8

REP 10 OPE Unit

- Open the ADF Housing and insert a flat-blade screwdriver into the crack and remove the OPE Unit from the Platen Housing.

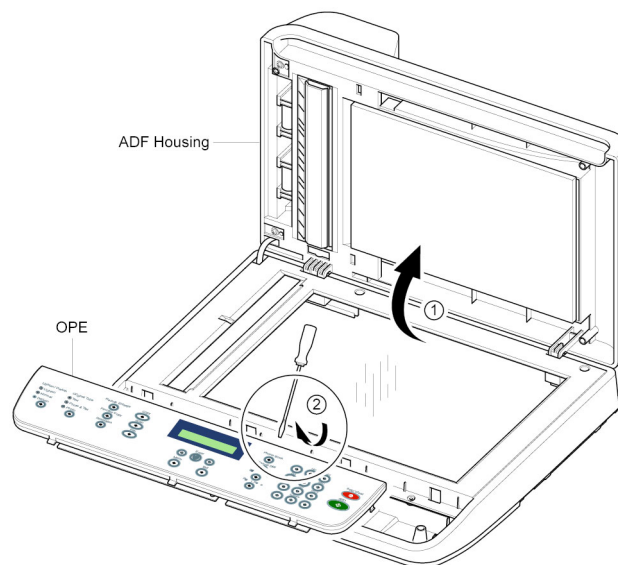

Figure 1

- Unplug the three Connectors (Battery, OPE, Full Sensor).

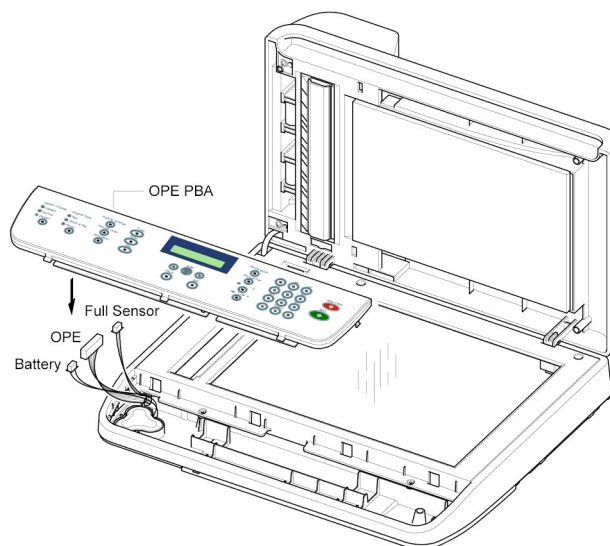

Figure 2

- Remove the screws securing the OPE PBA and remove it.
- Release the Contact Rubbers.
- Release the Keys.

REP 11 Platen Housing

1. Before you remove the Platen Housing, you should remove:
 - Scan Assembly (Refer to [REP 8](#))
 - ADF Housing (Refer to [REP 9](#))
 - OPE Unit (Refer to [REP 10](#))
2. Remove five screws from the Scan Upper and remove it from the Scan Lower.

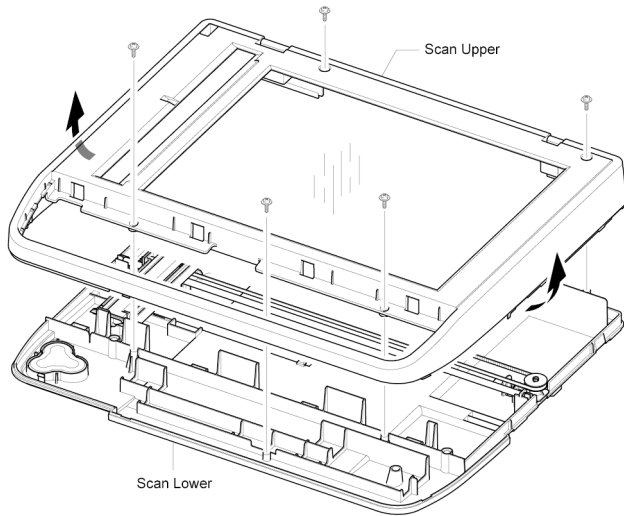

Figure 1

3. Take out the Battery.

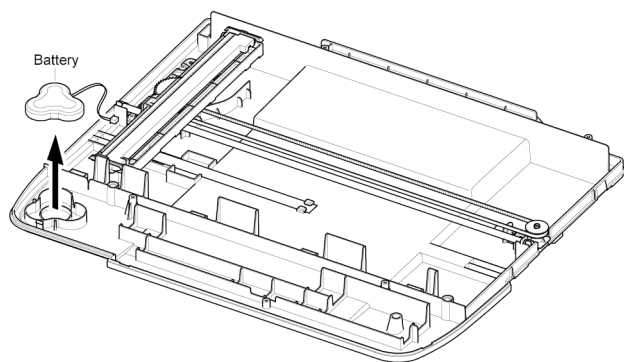

Figure 2

4. Push the Holder in the direction of arrow and remove the Belt, as shown below. (The CIS will come out at the same time.)

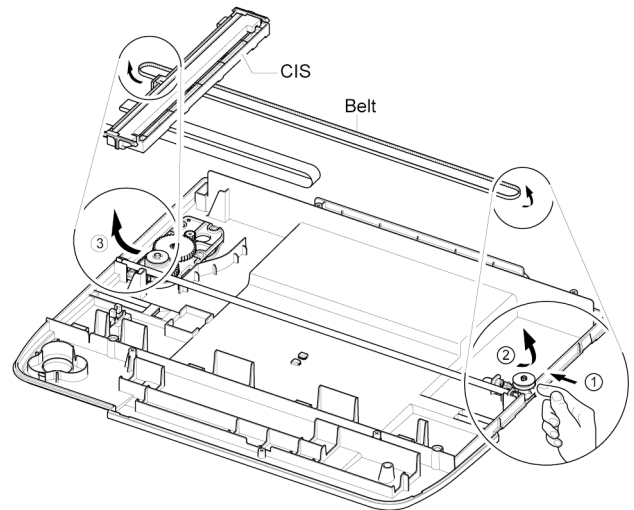

Figure 3

5. Release the Belt and Flat Cable from the CIS.

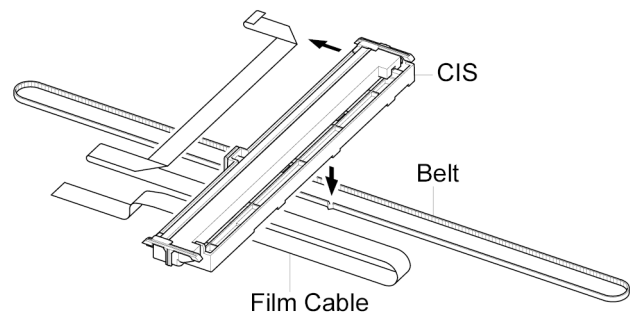

Figure 4

6. Remove two screws securing the Scan Motor Assembly and remove it.

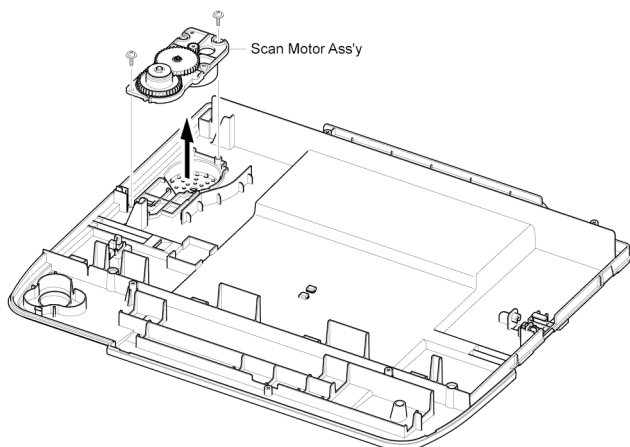

Figure 5

7. If necessary, remove two screws securing the Scan Motor and remove it.

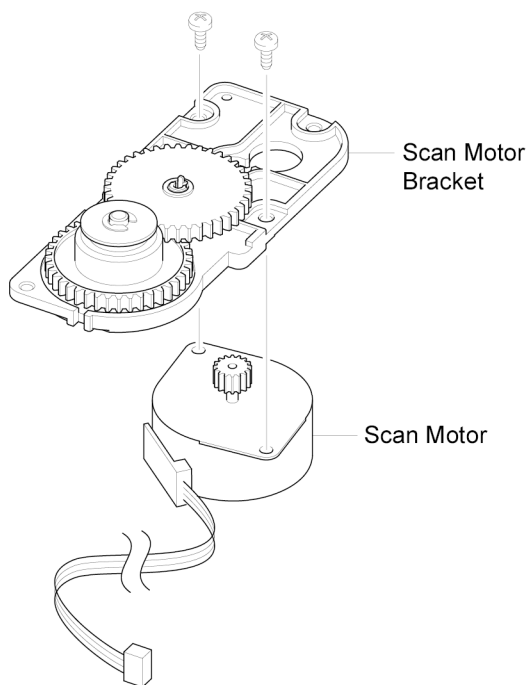

Figure 6

8. Using a flat-blade screwdriver remove the Full Sensor.

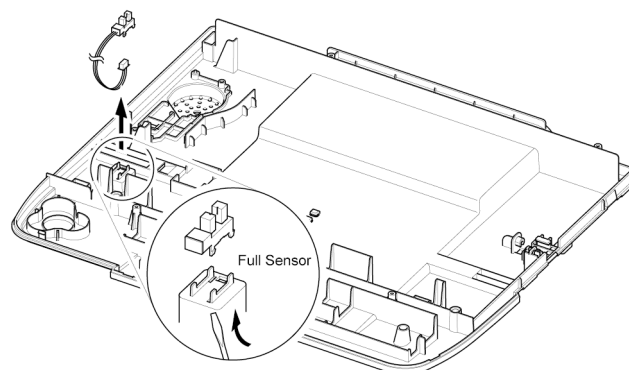

Figure 7

REP 12 Middle Cover

1. Before you remove the Middle Cover, you should remove:
 - Scan Assembly (Refer to [REP 8](#))
2. Remove five screws securing the Middle Cover.

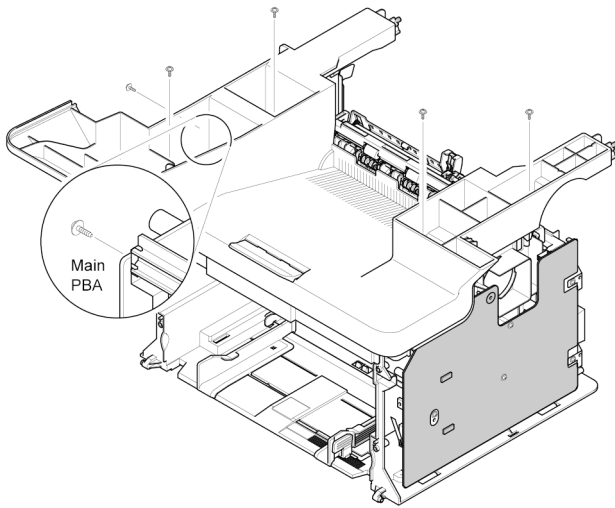

Figure 1

3. Carefully release the Middle Cover from the Main PBA.

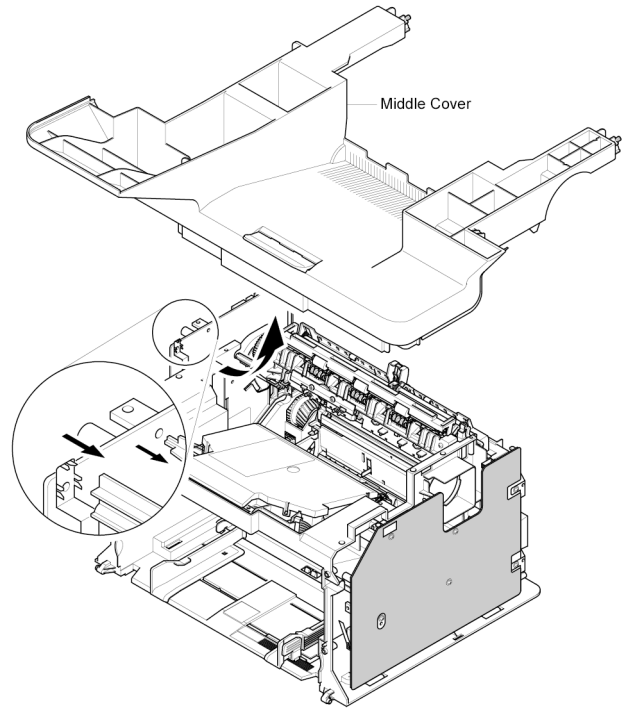

Figure 2

4. If necessary, take out the Stacker.

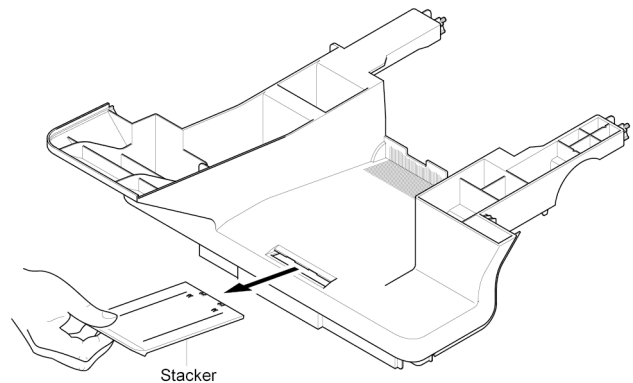

Figure 3

REP 13 HVPS

1. Before you remove the HVPS, you should remove:
 - Scan Assembly (Refer to [REP 8](#))
 - Middle Cover (Refer to [REP 12](#))
2. Remove five screws securing the HVPS and remove it with the HVPS Ground.

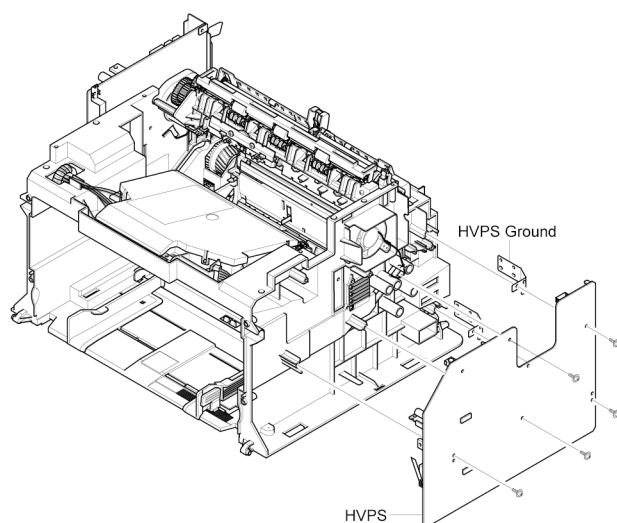

Figure 1

3. Unplug the Connector from the HVPS.
HVPS Ground

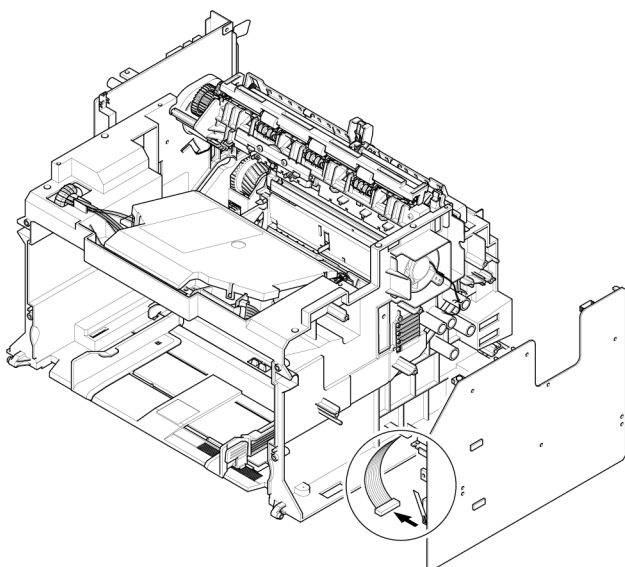

Figure 2

REP 14 Main PBA

1. Before you remove the Main PBA, you should remove:
 - Scan Assembly (Refer to [REP 8](#))
 - Middle Cover (Refer to [REP 12](#))
2. Unplug the all Connectors from the Main PBA, as shown below.

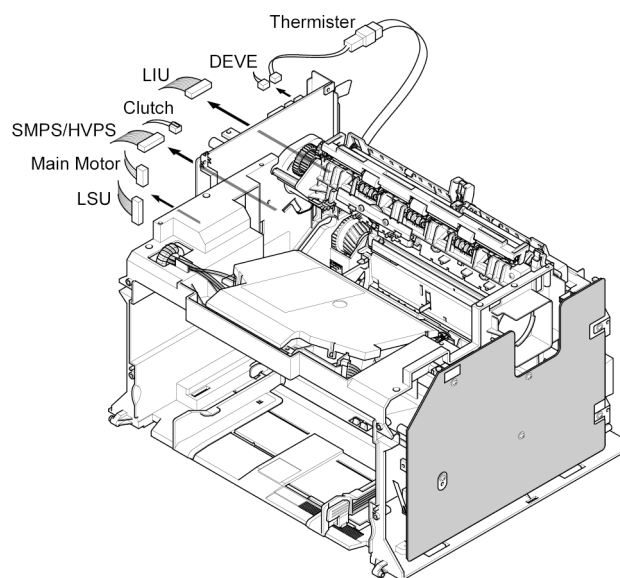

Figure 1

3. Remove six screws securing the Main PBA and remove it.

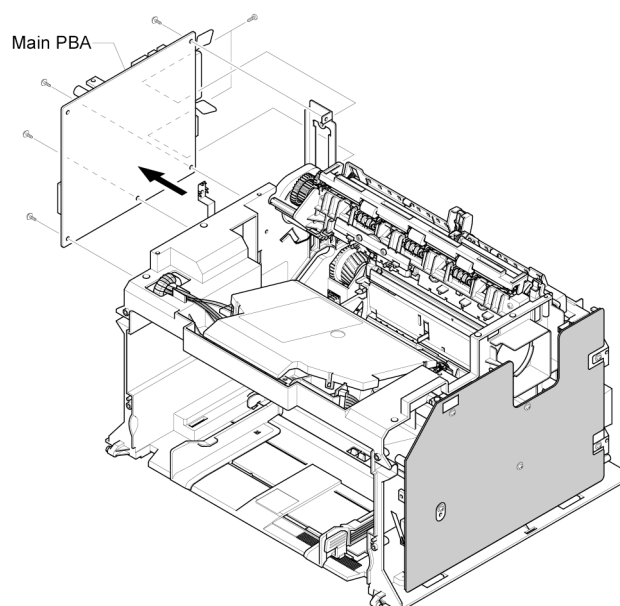

Figure 2

REP 15 RX Drive

1. Before you remove the RX Drive, you should remove:
 - Scan Assembly (Refer to [REP 8](#))
 - Middle Cover (Refer to [REP 12](#))
 - Main PBA (Refer to [REP 14](#))
2. If necessary, remove Bracket Port, Bracket Main PBA and Ground.

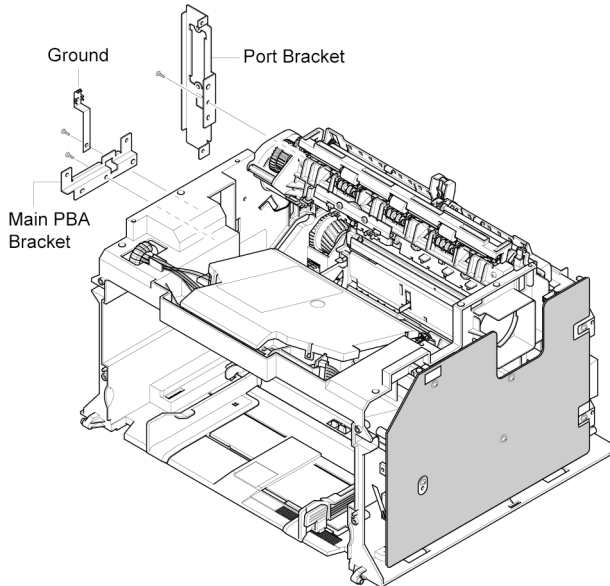

Figure 1

3. Remove two screws securing the Engine Shield and remove six screws securing the Frame, then remove the RX Drive in the direction of the arrow.

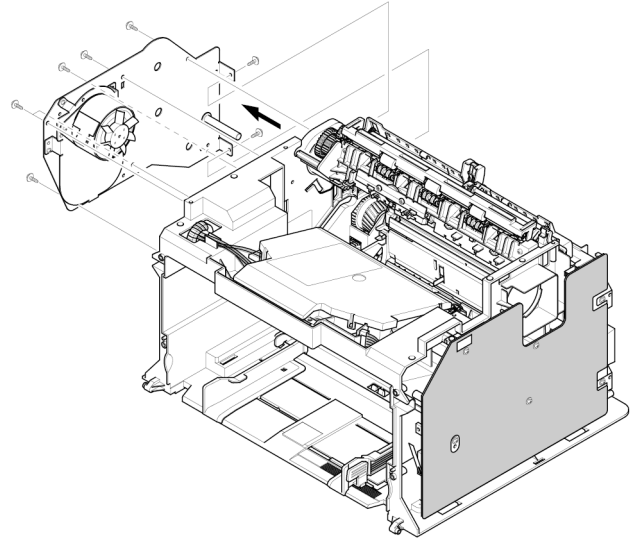

Figure 2

4. Remove the Connector.

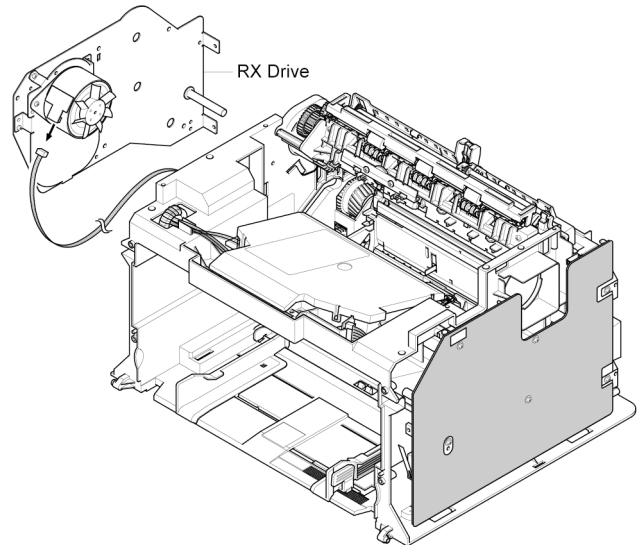

Figure 3

5. Release the four Gears (RDCN, OPC, Fuser, Feed) from the Frame.

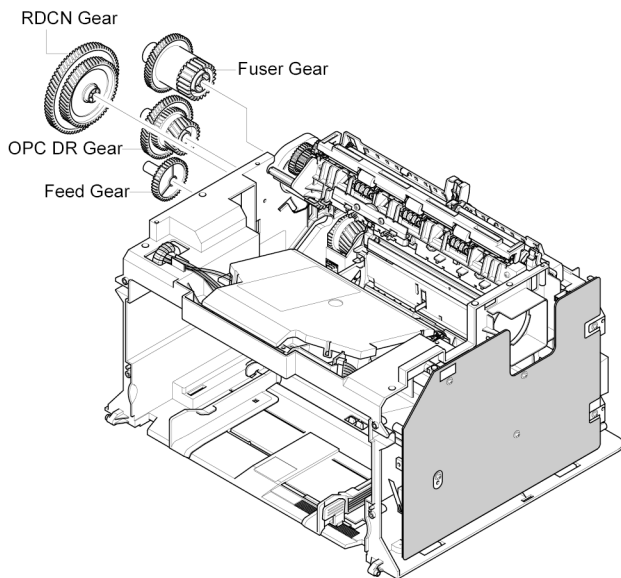

Figure 4

6. Remove four screws securing the Motor Bracket and remove it. Then remove two screws securing the Motor and remove it.

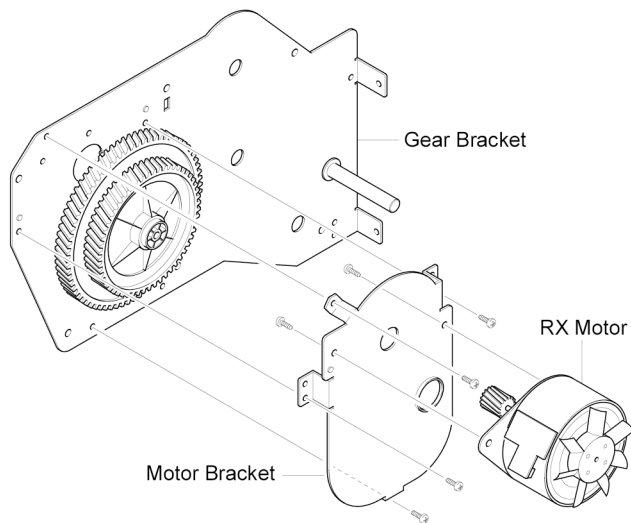

Figure 5

REP 16 Fuser

- Before you remove the Fuser, you should remove:
 - Scan Assembly (Refer to [REP 8](#))
 - Middle Cover (Refer to [REP 12](#))
- Unplug the two Connectors from the SMPS and Main PBA.

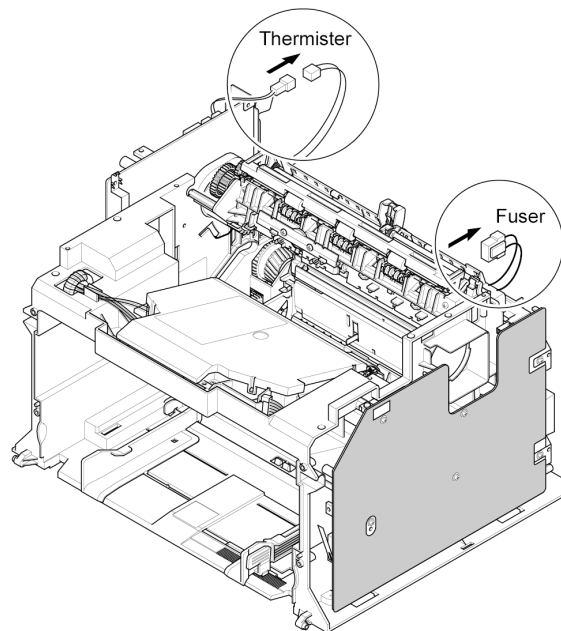

Figure 1

- Remove four screws securing the Fuser and remove it.

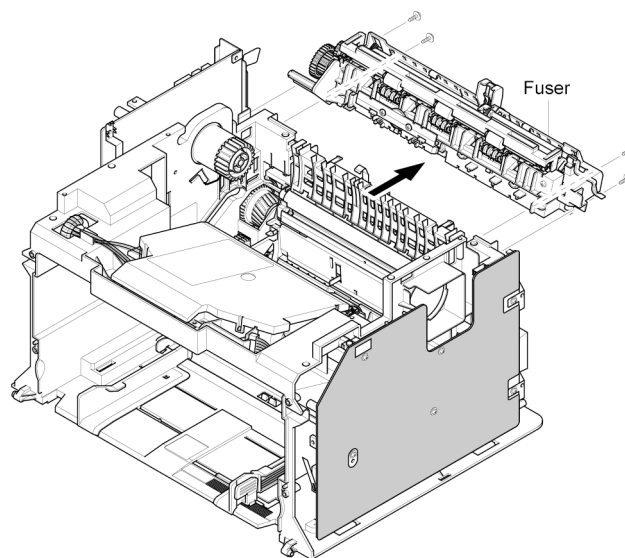

Figure 2

4. Remove the Lever-M-Act Exit in the direction of arrow.

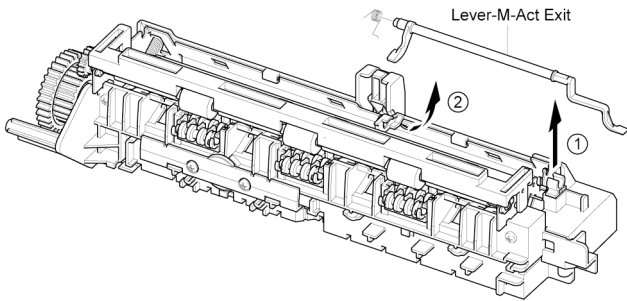

Figure 3

5. Remove the Cover-M-Safety.

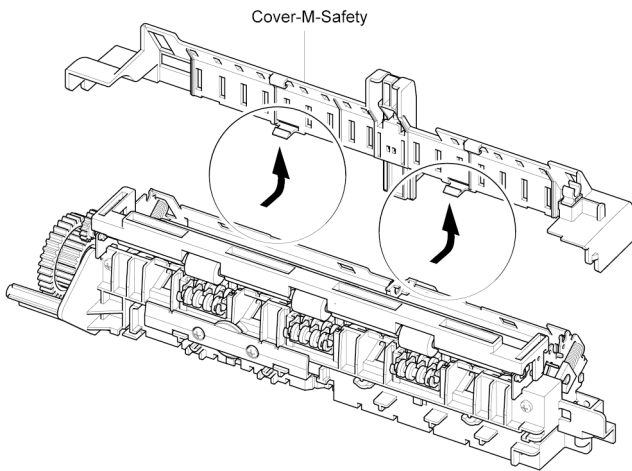

Figure 4

6. Remove the Cover-M-Guide Exit.

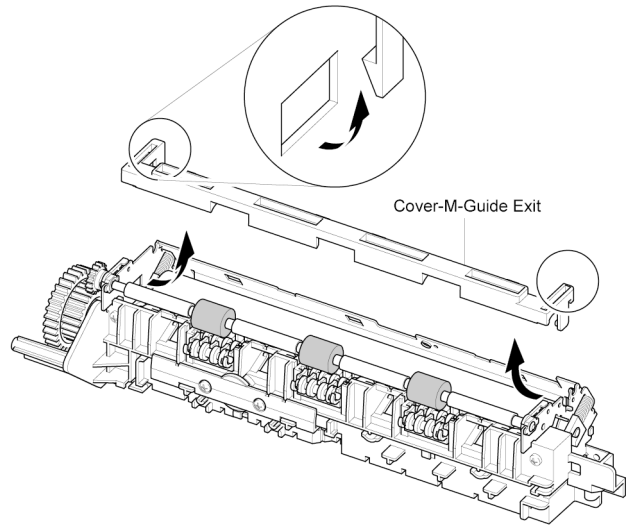

Figure 5

7. Rotate the Holder in the direction of the arrow which is attached to the Exit Roller F/Down and Exit Gear (DRV17). (The Roller_Main, Roller_FR, F/Down Holder, Spring will come out at the same time.)

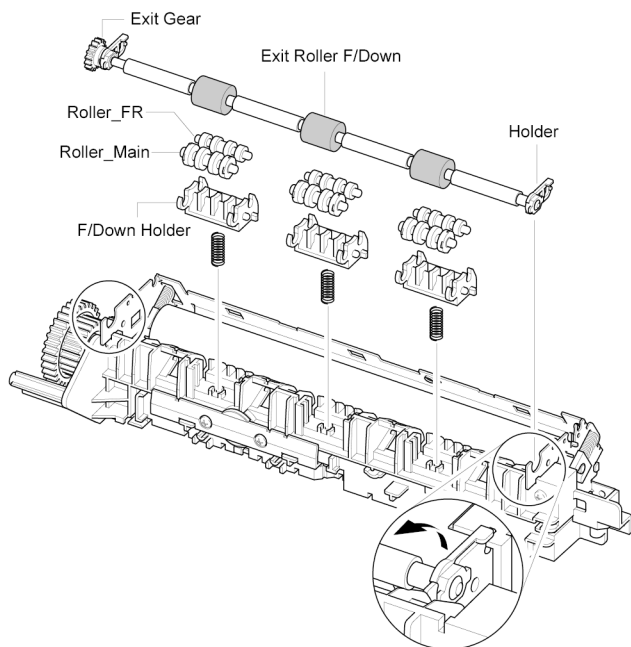

Figure 6

Note: If you don't follow the direction above the Spring will come out forcing the Roller_Main, Roller_FR, F/Down Holder inside the Frame Assembly.

8. Remove two screws securing the Thermo Cap and remove it.

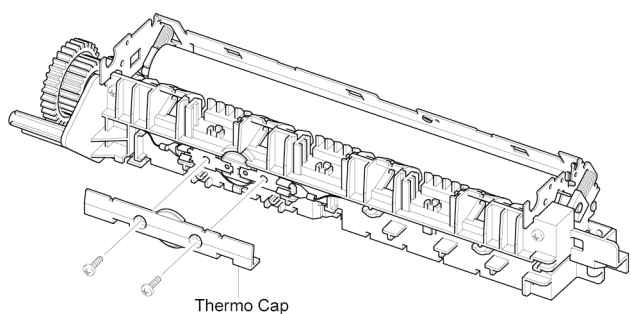

Figure 7

9. Pull out the Thermostat and release the CBF Harness.

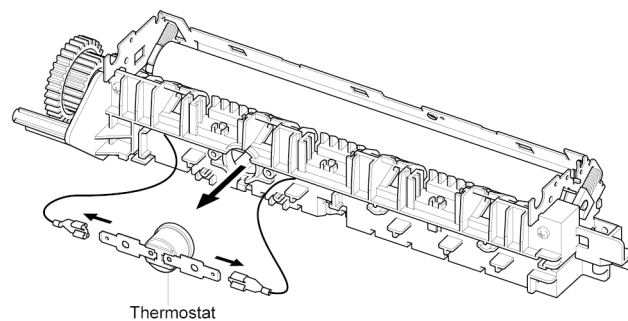

Figure 8

10. Remove the screw securing the Harness then take out the Thermistor.

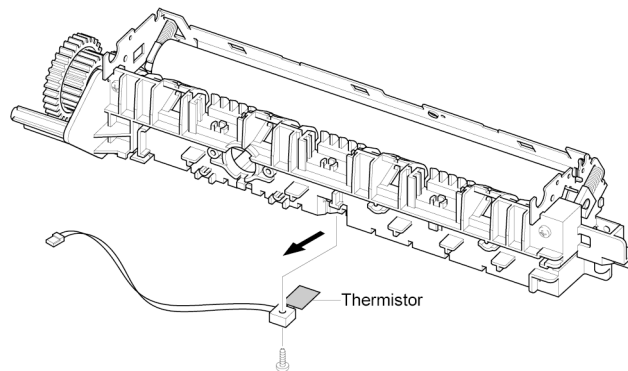

Figure 9

11. Release the CBF Harness from the Halogen Lamp and remove two screws securing the Halogen Lamp.

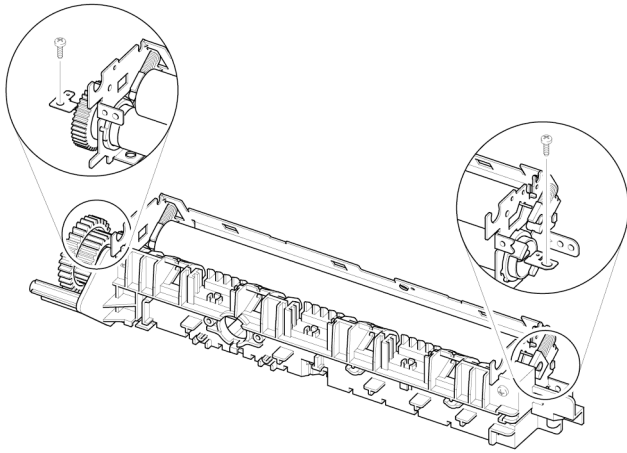

Figure 10

12. Remove two screws securing the Cover-M and remove it.

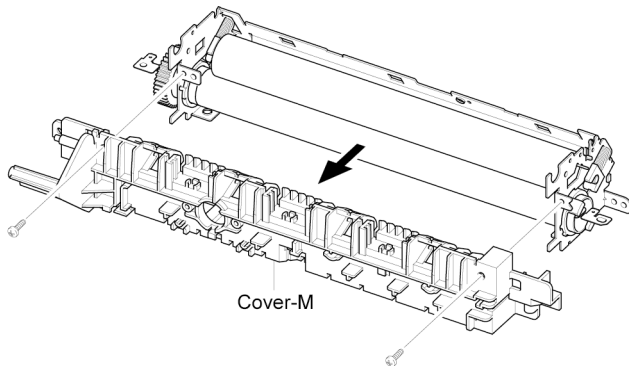

Figure 11

CAUTION

Do not touch the lamp body (glass). Contamination from your fingers can cause the lamp to fail.

13. Take out the Halogen Lamp in the direction of arrow.

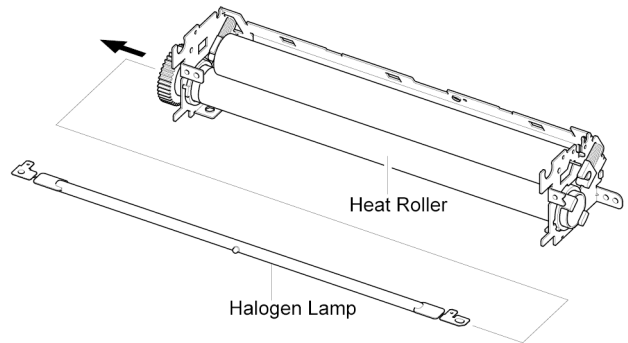

Figure 12

REP 17 Engine Shield (LIU PBA, SMPS)

- Before you remove the Engine Shield, you should remove:
 - Scan Assembly (Refer to [REP 8](#))
 - Middle Cover (Refer to [REP 12](#))
- Unplug all Connectors from the SMPS and LIU PBA.

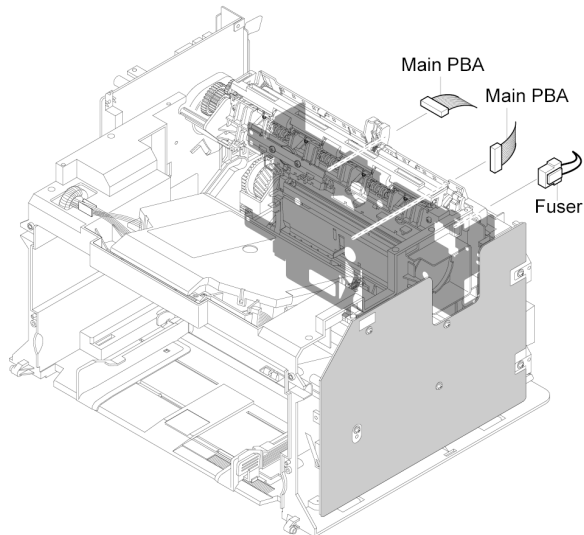

Figure 1

- Remove six screws securing the Engine Shield and release the Harness. Carefully release the Engine Shield from the Actuator Feed Sensor Lever.

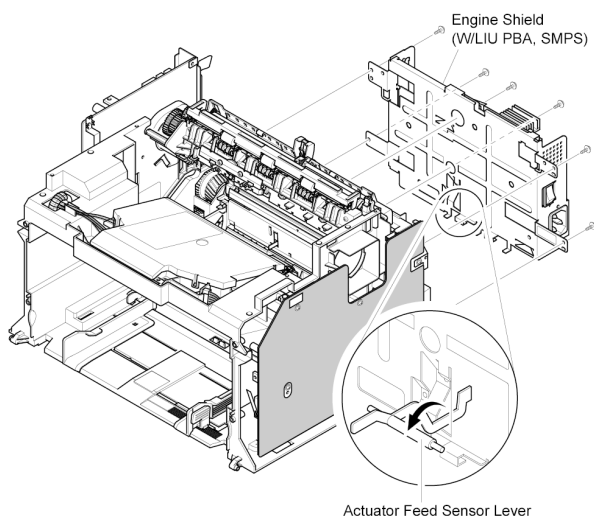

Figure 2

- If only removing the SMPS, remove the Rear Cover (refer to [REP 5](#)) and unplug the Fuser Connector. Remove six screws securing the SMPS. Unplug the Connector from the Main PBA and carefully release the SMPS.

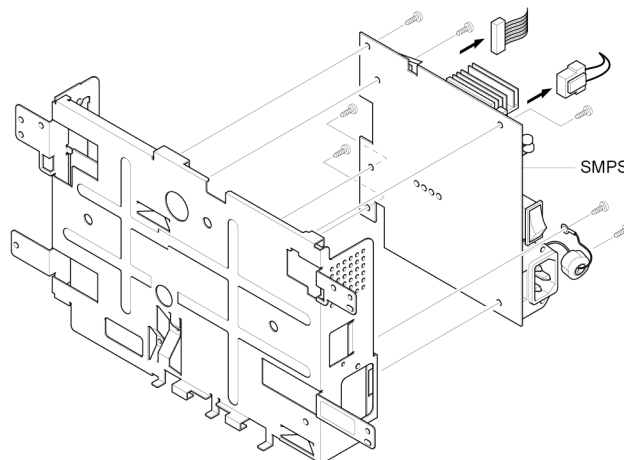

Figure 3

- If only removing the LIU PBA, remove the Rear Cover (refer to [REP 5](#)) and remove two screws securing the LIU PBA. Unplug the Connector from the Main PBA and release the LIU PBA.

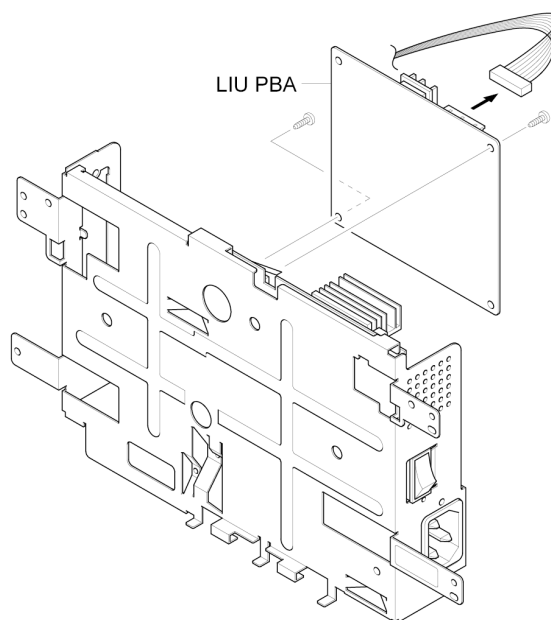

Figure 4

REP 18 LSU

CAUTION

Do not touch the LSU Glass Window. Contamination on the LSU Glass Window can lead to Image Quality problems.

1. Before you remove the LSU, you should remove:
 - Scan Assembly (Refer to [REP 8](#))
 - Middle Cover (Refer to [REP 12](#))
2. Remove three screws securing the LSU and remove it. Unplug the two Connectors from the LSU.

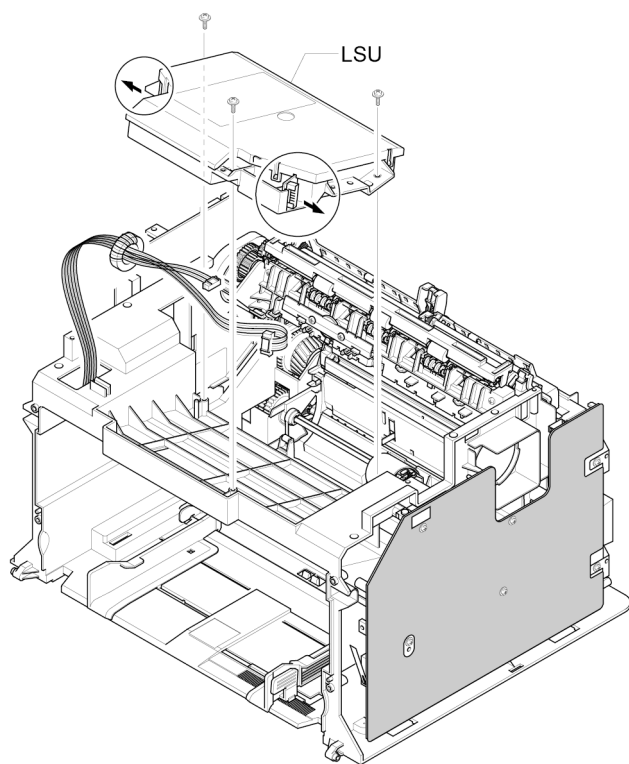

Figure 1

REP 19 Paper Path Frame

- Before you remove the Paper Path Frame, you should remove:
 - Scan Assembly (Refer to [REP 8](#))
 - Middle Cover (Refer to [REP 12](#))
 - Fuser (Refer to [REP 16](#))
 - Engine Shield (Refer to [REP 17](#))
- Remove four screws securing the Paper Path Frame and remove it in the direction of the arrow.

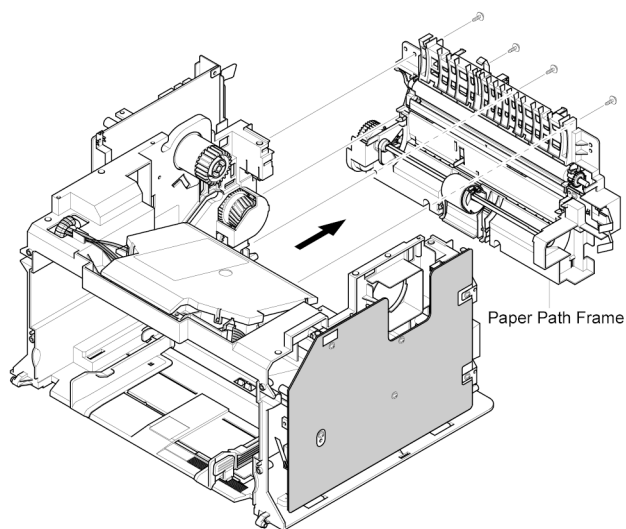

Figure 1

- Remove the Transfer Roller from the Frame.

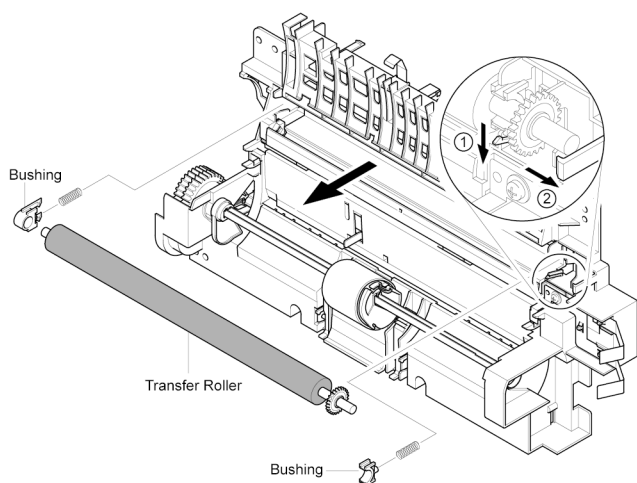

Figure 2

- Remove the screw securing the Solenoid-MP and remove it.

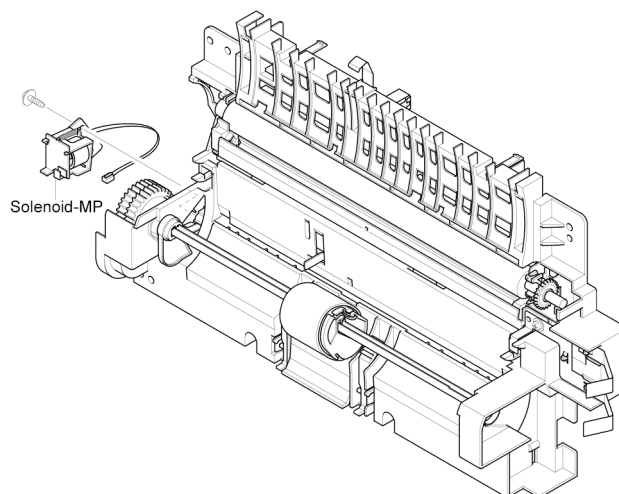

Figure 3

Page intentionally blank

5. Spare Parts List

PL 1 Main Assembly [5-2](#)
PL 2 ADF Assembly [5-4](#)
PL 3 Platen Cover Assembly [5-6](#)
PL 4 ADF Platen Assembly [5-8](#)
PL 5 OPE Unit [5-10](#)
PL 6 Paper Path Assembly [5-12](#)
PL 7 Fuser Unit [5-14](#)
PL 8 Main Frame Assembly [5-16](#)
PL 9 MP Tray Assembly [5-18](#)
PL 10 Common Hardware & General Service Items [5-20](#)

PL 1 Main Assembly

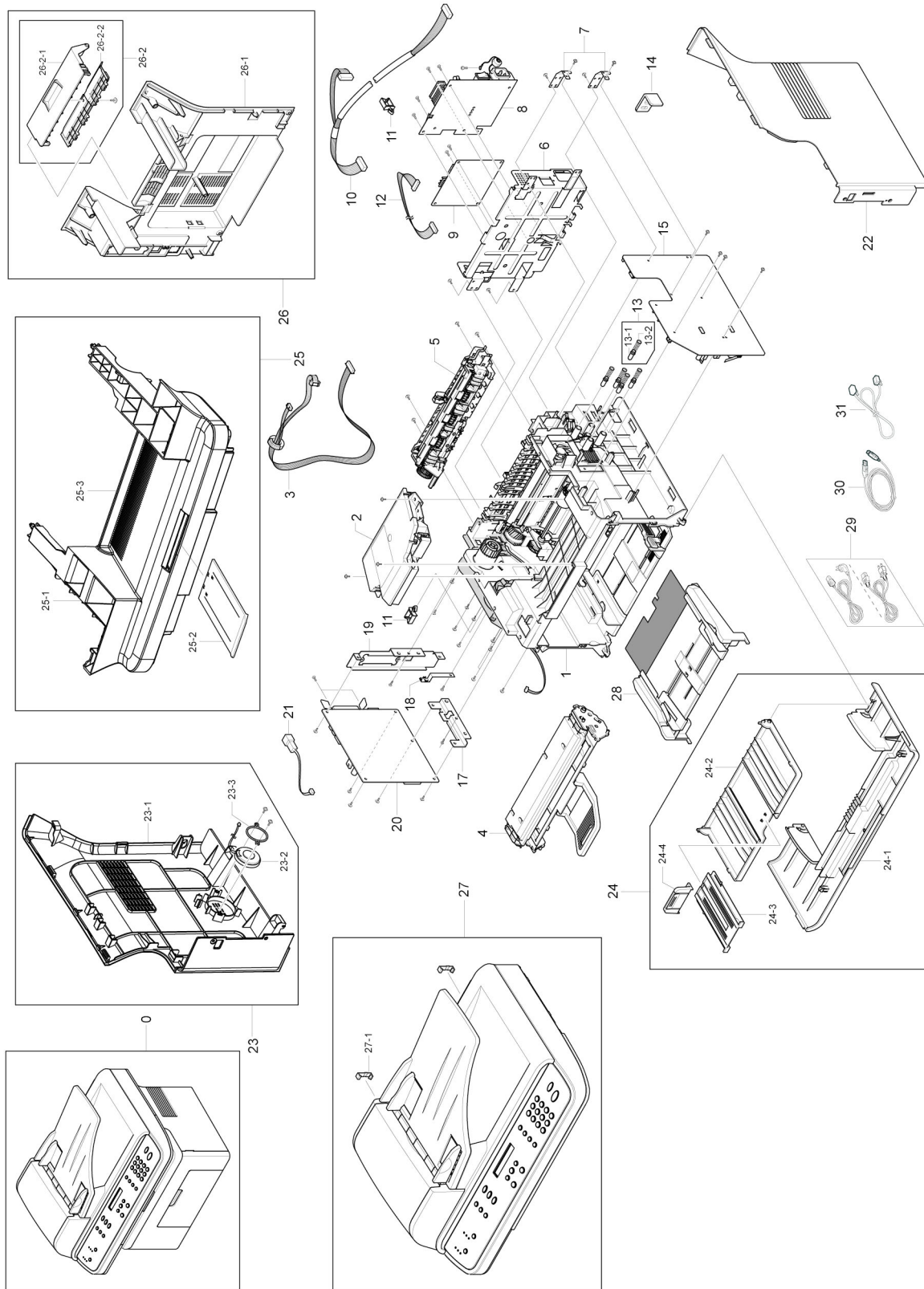

PL 1 Main Assembly

Item	Part Number	Description	Qt'y	Remark
0		SET		
1		ELA HOU-FRAME LOWER (REFER TO PL 8)	1	
2	122N00243	UNIT-LSU	1	
3		CBF HARNESS-LSU	1	
4		INITIAL(1K) PRINT CARTRIDGE	1	
5	101N01380	FUSER_110V (REFER TO PL 7)	1	
5	101N01381	FUSER_220V (REFER TO PL 7)	1	
6		SHEILD-P-ENGINE	1	
7		GROUND-P-HVPS	2	
8	105N02066	SMPS 110V	1	
8	105N02067	SMPS 220V	1	
9	140N63039	PBA SUB-LIU WESTERN EUROPE	1	
9	140N63038	PBA SUB-LIU US/CANADA/SAUDI ARABIA/RUSSIA...	1	
10		CBF HARNESS HVPS	1	
11		HARNESS CLAMP	1	
12		CBF HARNESS LIU	1	
13	116N00244	ELA UNIT-TERMINAL TR L	5	
13-1		SPRING ETC-HV LARGE	1	
13-2		ICT-SHAFT HV LARGE	1	
14	015N00557	PLATE-P-CHANNEL	1	
15	105N02068	HVPS	1	
16	NOT USED			
17		BRACKET-P-MAIN BOARD	1	
18	117N01691	GROUND-P-MAIN BOARD	1	
19	030N00711	BRACKET-P-PORT	1	
20	140N63040	PBA MAIN	1	
21		ELA HOU-FULL SENSOR HARNESS	1	
21-1		PHOTO INTERRUPTER	1	
21-2		CBF HARNESS-JAM_SENSOR	1	
22	002N02429	COVER-M-SIDE R	1	
23	002N02430	ELA HOU-COVER SIDE L	1	
23-1	002N02431	COVER-M-SIDE L	1	
23-2	130N01412	SPEAKER	1	
23-3		IPR-UNIT FIXING BRACKET	1	
24	002N02432	MEA-COVER FRONT	1	
24-1		COVER-M-FRONT	1	
24-2	050N00480	TRAY-M-CASSETTE	1	
24-3		TRAY-M-EXTENSION LARGE	1	
24-4		TRAY-M-EXTENSION SMALL	1	
25	002N02433	ELA HOU-COVER MIDDLE	1	
25-1		COVER-M-MIDDLE	1	
25-2		PMO-M-STACKER	1	
25-3		SHEET-FAN	1	
26	002N02435	MEA UNIT-COVER REAR	1	
26-1		COVER-M-REAR	1	
26-2		MEA UNIT-COVER JAM	1	
26-2-1		COVER-M-JAM	1	
26-2-2		COVER-M-JAM DUMMY	1	
27	002N02435	ELA HOU-SCAN (ALSO REFER TO PL 2 , PL 3 & PL 4)	1	
27-1	021N02251	CAP-M-HINGE	2	
28		MEA UNIT-MP TRAY (REFER TO PL 9)	1'	
29		AC POWER CORD (US VER.) (REFER TO PL 10)	1	
30		USB CABLE (REFER TO PL 10)	1	
31		TELEPHONE LINE CORD (US VER.) (REFER TO PL 10)	1	

PL 2 ADF Assembly

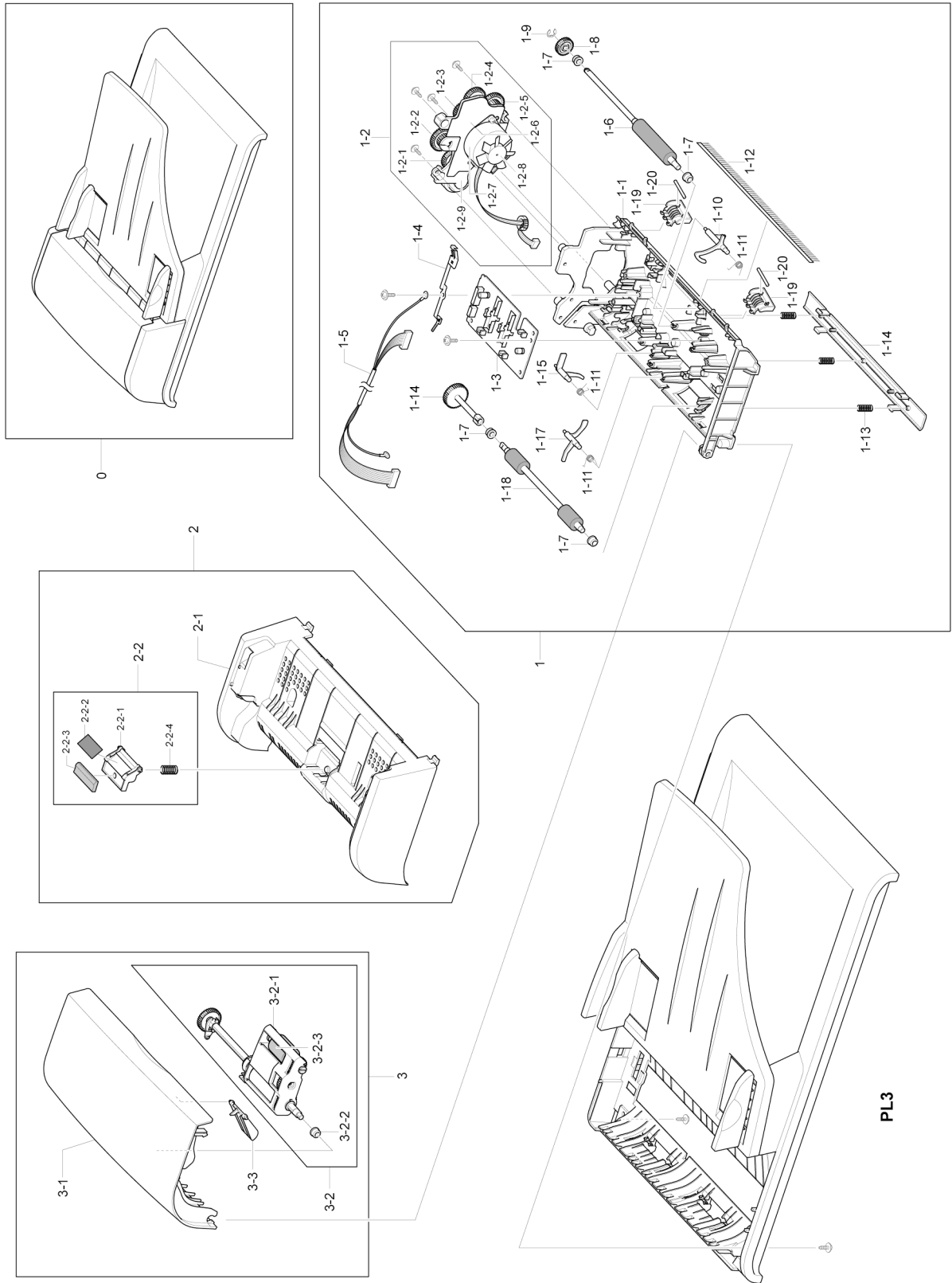

PL 2 ADF Assembly

Item	Part Number	Description	Qt'y	Remark
0	002N02441	ELA HOU-ADF	1	
1	002N02444	ELA HOU-ADF LOWER	1	
1-1		COVER-M-ADF LOWER	1	
1-2	002N02445	ELA HOU-ADF MOTOR	1	
1-2-1		GEAR-IDLE 35 ADF	3	
1-2-2	007N01369	GEAR-CLUTCH 39	1	
1-2-3		GEAR-SWING 31/20 ADF	1	
1-2-4		GEAR-58/25 ADF	1	
1-2-5	007N01370	GEAR-40/21 ADF	2	
1-2-6		BRACKET-P-MOTOR	1	
1-2-7		MOTOR STEP-ADF	1	
1-2-8		IMPELLER-ADF	1	
1-2-9		BRACKET-M-GEAR	1	
1-3	140N63041	PBA SUB-ADF	1	
1-4		GROUND-P-ADF	1	
1-5		CBF HARNESS-ADF	1	
1-6		ROLLER-DRIVE	1	
1-7	013N13842	PMO-BUSH	4	
1-8	007N01368	SHAFT-M-FEED GEAR 38	1	
1-9		RING-C	1	
1-10	130N01413	PMO-ACTUATOR SCAN SENSOR	1	
1-11	009N01512	SPRING-CS	3	
1-12	115N00856	MEC-BRUSH ANTISTATIC	1	
1-13	009N01513	SPRING ETC-TORSION DOC (CC2-F)	3	
1-14	015N00559	PLATE-M_WHITE BAR	1	
1-15		PMO-ACTUATOR DOC SENSOR	1	
1-16		GEAR-CLUTCH 29	1	
1-17		PMO-ACTUATOR REGI SENSOR	1	
1-18		ROLLER-EXIT	1	
1-19		GUIDE-STACKER SUB	2	
1-20		SHAFT-IDLE FEED	2	
2	002N02446	MEA-ADF UPPER	1	
2-1		COVER-M-ADF UPPER	1	
2-2	500N00107	MEA UNIT-HOLDER ADF	1	
2-2-1		HOLDER-M-ADF	1	
2-2-2	019N00842	SHEET-ADF HOLDER	1	
2-2-3	019N00566	ADF RUBBER	1	
2-2-4	019N00843	SPRING ETC-PAD	1	
3	002N02447	MEA-COVER OPEN	1	
3-1		COVER-M-ADF OPEN	1	
3-2	130N01414	MEA UNIT PICKUP ADF	1	
3-2-1	022N02190	MEC-ADF ROLLER ASSEMBLY	1	
3-2-2	013N13842	PMO-BUSH	1	
3-2-3	022N02191	MEC-PICK UP ROLLER ASSEMBLY	1	
3-3	038N00462	PMO-GUIDE PAPER	1	

PL 3 Platen Cover Assembly

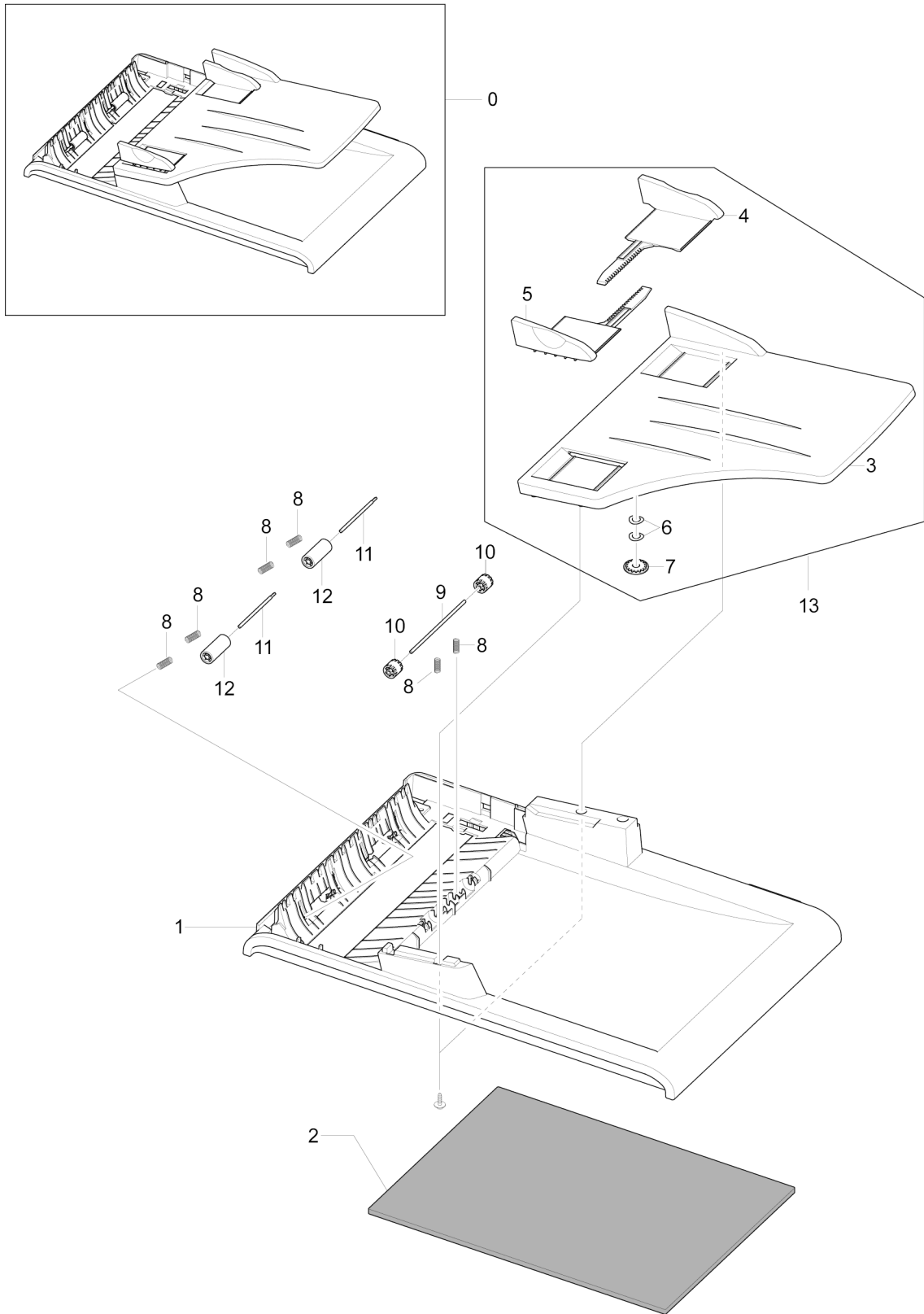

PL 3 Platen Cover Assembly

Item	Part Number	Description	Qt'y	Remark
0	002N02448	MEA-COVER PLATEN	1	
1	002N02436	COVER-M-PLATEN	1	
2	095N00274	SHEET-WHITE SPONGE	1	
3	038N00405	PMO-TX STACKER	1	
4	38N00410	PMO-DOC GUIDE(R)	1	
5	38N00406	PMO-DOC GUIDE(L)	1	
6	028N00321	IPR-WASHER SPRING CU	2	
7	007N01178	GEAR-PINION	1	
8	009N01514	SPRING ETC-FEED	6	
9		SHAFT PINCH	1	
10	022N02014	PMO-ROLL PINCH	2	
11		SHAFT-IDLE FEED	2	
12	022N02019	RPR-ROLLER EXIT IDLE	2	
13	050N00479	MEA-TX STACKER	1	

PL 4 ADF Platen Assembly

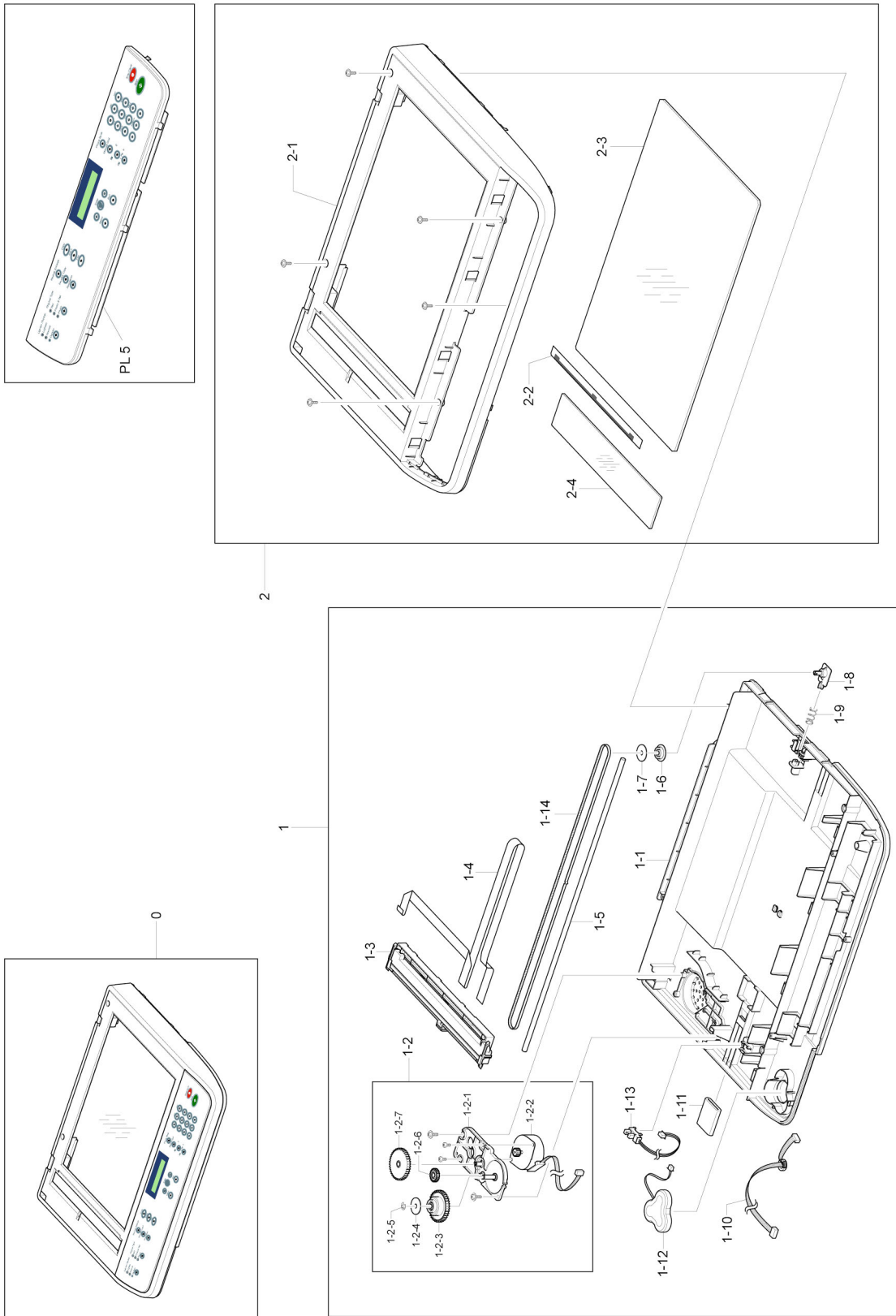

PL 4 ADF Platen Assembly

Item	Part Number	Description	Qt'y	Remark
0	002N02443	ELA HOU-PLATEN	1	
1	002N02449	ELA HOU-SCAN LOWER	1	
1-1	002N02450	COVER-M-SCAN LOWER	1	
1-2	101N01345	ELA HOU-SCAN MOTOR	1	
1-2-1		BRACKET-M-SCAN MOTOR	1	
1-2-2	127N07398	MOTOR STEP-SCAN	1	
1-2-3		GEAR-TIMING	1	
1-2-4		PMO-HOLDER BELT	1	
1-2-5		RING-E	1	
1-2-6		GEAR-IDLE	1	
1-2-7		GEAR-REDUCTION	1	
1-3	130N01415	CONTACT IMAGE SENSOR (CIS)	1	
1-4		CBF SIGNAL-CIS FFC	1	
1-5		SHAFT-CIS	1	
1-6	023N01140	PMO-HOLDER BELT_1	1	
1-7		PMO-HOLDER BELT_2	1	
1-8		PMO-PULLEY	1	
1-9	009N01515	SPRING ETC-BELT	1	
1-12	121N01112	BATTERY	2	
1-13	152N11632	ELA HOME-FULL SENSOR HARNESS	1	
1-14	109N00542	BELT-TIMING GEAR	1	
2	109N00650	MEA-SCAN UPPER	1	
2-1	002N02438	COVER-M-SCAN UPPER	1	
2-2	091N80223	LABEL(P)-SHADING	1	
2-3	062N00266	GLASS-ADF	1	
2-4	090N00161	GLASS-PLATEN	1	

PL 5 OPE Unit

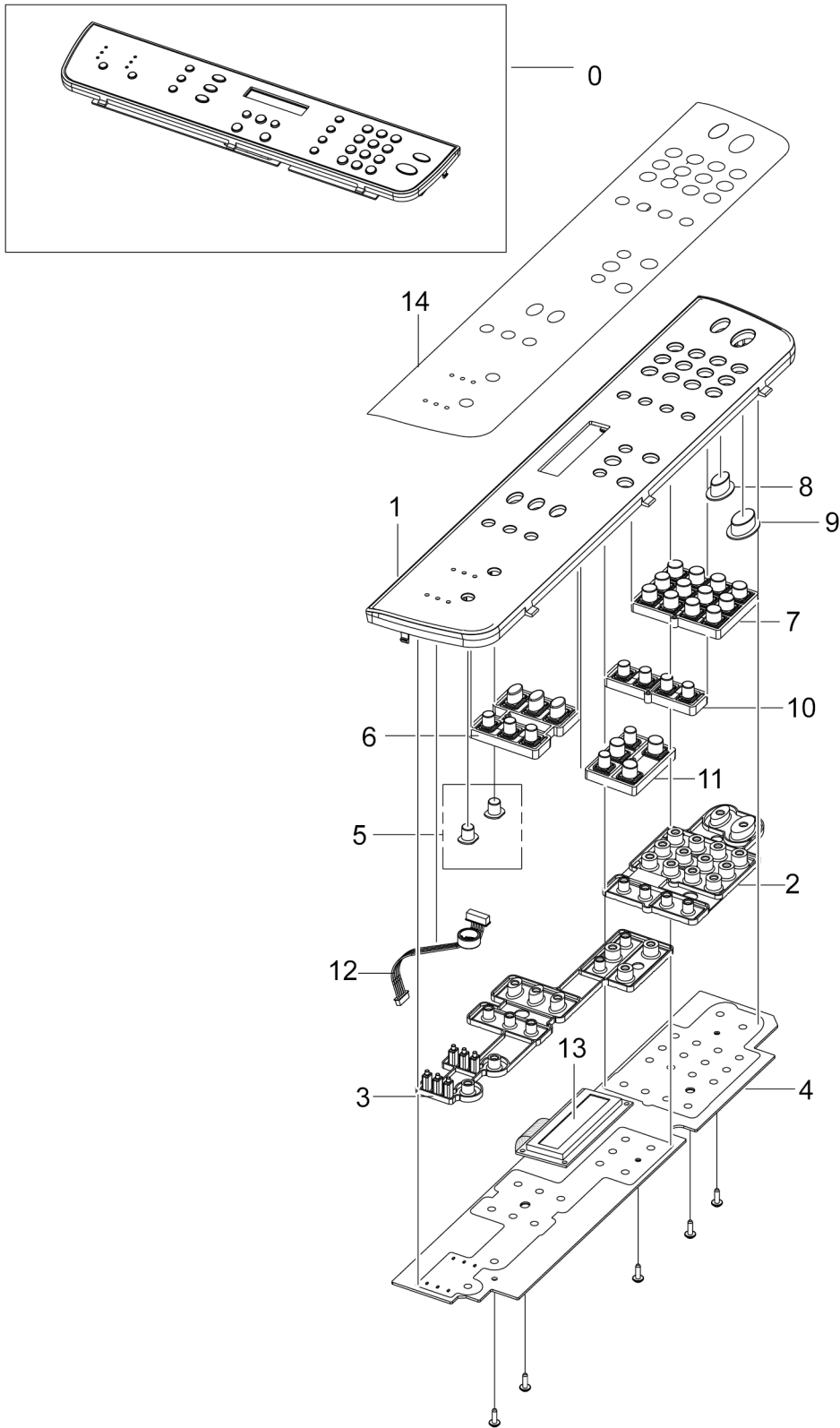

PL 5 OPE Unit

Item	Part Number	Description	Qt'y	Remark
0	002N02442	ELA HOU-OPE(XEROX)	1	
1	002N02437	COVER-M-OPE	1	
2	110N01390	RUBBER-TEL	1	
3	110N01391	RUBBER-SCROLL	1	
4	140N63042	PBA SUB-OPE	1	
5	003N00972	KEY-M_SHIFT	1	
6	029N00367	KEY-M_STATUS	1	
7	003N00969	KEY-M_TEL_R2_XRX	1	
8	003N00893	KEY-M-STOP	1	
9	003N00970	KEY-M_START_XRX	1	
10	029N00368	KEY-M_FAX	1	
11	003N00971	KEY-M_SCROLL_R2X	1	
12	152N11627	CBF HARNESS-OPE	1	
13		LCD DISPLAY	1	
14...	002N02421	SHEET-OVERLAY ENGLISH	1	
14...	002N02422	SHEET-OVERLAY SPANISH	1	
14...	002N02423	SHEET-OVERLAY BRAZILIAN PORTUGUESE	1	
14...	002N02424	SHEET-OVERLAY FRENCH	1	
14...	002N02425	SHEET-OVERLAY RUSSIAN	1	

PL 6 Paper Path Assembly

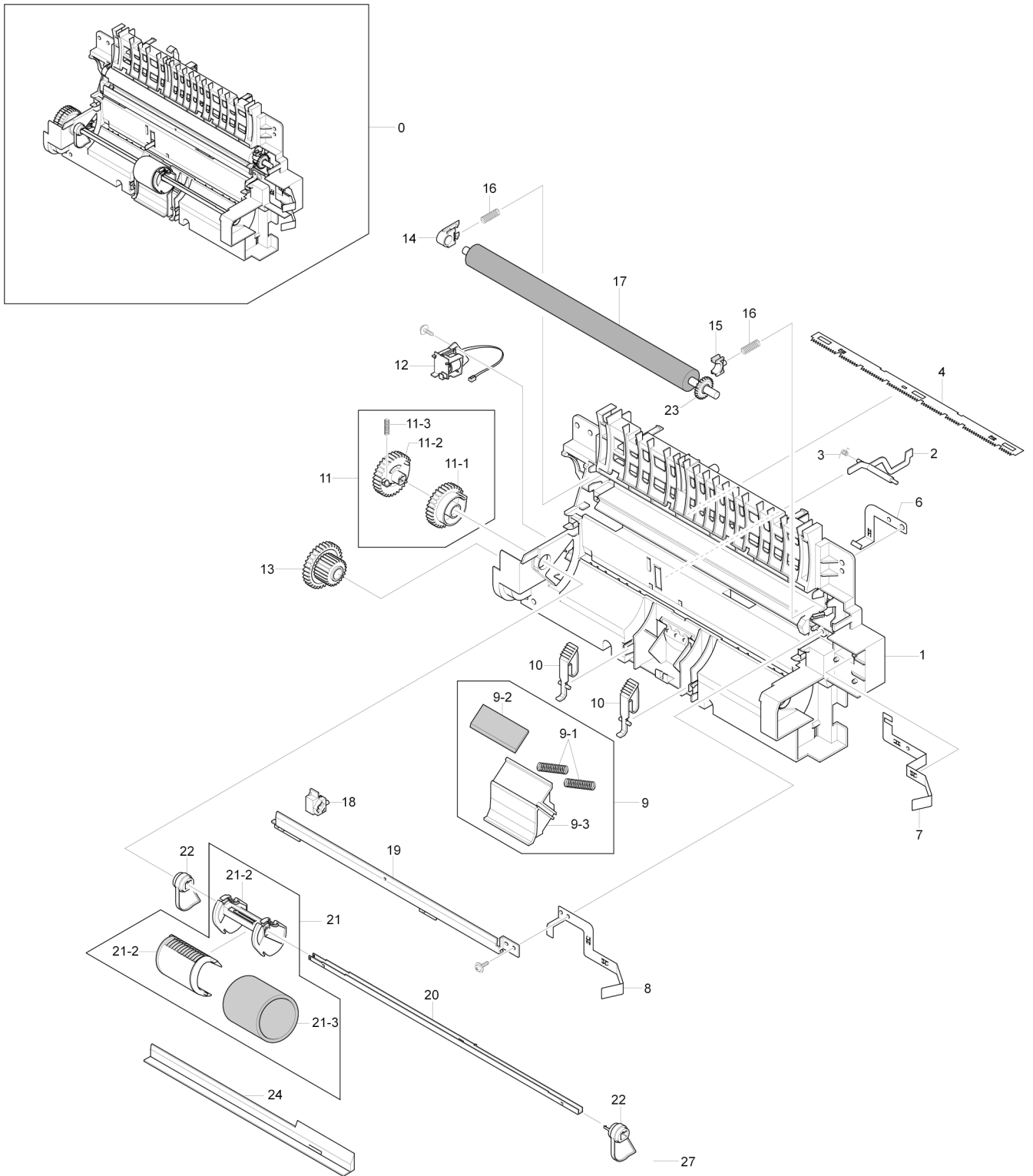

PL 6 Paper Path Assembly

Item	Part Number	Description	Qt'y	Remark
0		PAPER-PATH ASSEM	1	
1	038N00463	GUIDE-M-PAPER PATH	1	
2	130N01408	LEVER-ACTUATOR FEED SENSOR	1	
3	009N01519	SPRING ETC-LEVER SENSOR	1	
4	015N00558	IPR-PLATE SAW	1	
5	NOT USED			
6		GROUND-P-ZENER	1	
7		GROUND-P-THV	1	
8		GROUND-P-SAW	1	
9	019N00841	MEA UNIT-HOLDER_PAD	1	
9-1	009N01520	SPRING ETC-EXIT ROLL FD	2	
9-2	019N00836	PAD-FRICTION	1	
9-3	019N00837	HOLDER-M-PAD	1	
10		LEVER-M-KICKER P/U	2	
11	130N01419	MEA UNIT-PICK UP GEAR	1	
11-1		GEAR-PICK_UP B	1	
11-2		GEAR-PICK_UP A	1	
11-3		SPRING-CS	3	
12	121N01078	SOLENOID-MP_R2	3	
13	007N01375	GEAR-FEED 35/19	3	
14	016N00261	BUSH-M-TR L	1	
15	016N00281	PMO-BUSHING_TR(L)	1	
16	009N01521	SPRING ETC-TR(12)	2	
17	022N02126	ROLLER-TRANSFER	1	
18	019N00838	HOLDER-PTL	1	
19		IPR-P-EARTH TRANSFER	1	
20		SHAFT-P-PICK_UP	1	
21	130N01424	MEA UNIT PICK_UP	1	
21-1		HOUSING-M-PICK_UP B	1	
21-2		HOUSING-M-PICK_U	1	
21-3	130N01416	RUBBER-PICK_UP	1	
22	130N01410	CAM-M-PICK_UP	2	
23	007N01376	GEAR-TRANSFER	1	
24		BRACKET-P-BAR_PICK_UP	1	

PL 7 Fuser Unit

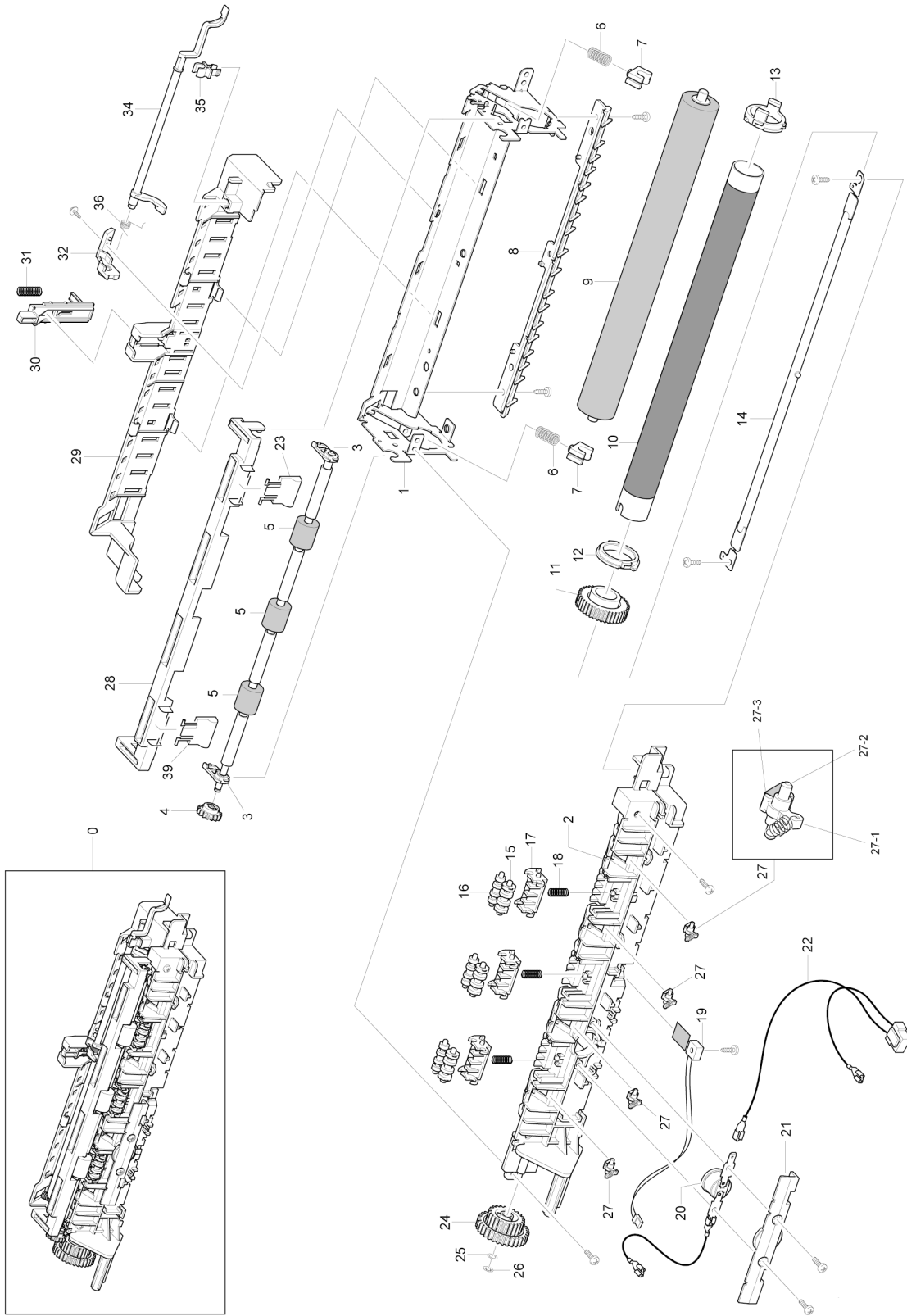

PL 7 Fuser Unit

Item	Part Number	Description	Qt'y	Remark
0	101N01381	FUSER_220V	1	
0	101N01380	FUSER_110V	1	
1		FRAME-P-FUSER	1	
2		COVER-M_FUSER	1	
3	019N00839	HOLDER-M-EXIT R	2	
4	007N01377	GEAR-EXIT_DRV17	1	
5		HOLDER-M-EXIT F/DOWN	3	
6		SPRING-CS	2	
7	013N13843	BEARING-PRESSURE/R	2	
8		GUIDE-M-INPUT	1	
9	022N01611	ROLLER-PRESSURE	1	
10	022N01610	ROLLER-HEAT	1	
11	007N01205	GEAR-FUSER, Z37	1	
12	016N00282	BUSH-M-HR L	1	
13	016N00262	BUSH-M-HR R	1	
14	122N00245	LAMP-HALOGEN_220V	1	
14	122N00246	LAMP-HALOGEN_110V	1	
15		ROLLER-M-EXIT MAIN	3	
16		ROLLER-M_EXIT FR	3	
18	009N01522	SPRING-CS	3	
19	130N01417	THERMISTOR-NTC	1	
20	130N01411	THERMOSTAT-150	1	
21	152N11628	CBF HARNESS-FUSER JOINT	1	
22	152N11626	CBF HARNESS-FUSER (220V)	1	
22	152N11631	CBF HARNESS-FUSER (110V)	1	
23		PADDLE	2	
24		GEAR EXIT-DR38/25	4	
25		WASHER-PLAIN	4	
26		E-CLIP	1	
27		STRIPPER FINGER	1	
27-1	009N01523	SPRING ETC-STRIPPER FINGER	4	
27-2	019N00840	HOLDER_M_PLATE STRIPPER FINGER	4	
27-3		PLATE-P-STRIPPER FINGER	4	
28		COVER-M-GUIDE EXIT	1	
29		COVER-M-SAFETY FUSER	1	
30		LEVER-M_ACT EXIT	1	
31		SPRING ETC-TR(KOR)	1	
32		HOLDER-M_ACTUATOR	1	
33		CBF HARNESS-THERMISTOR	1	
34		LEVER-M-ACTUATOR JAM	1	
35		PMO-BUSHING TX(B4)	1	
36		SPRING ETC-TORSION DOC (CC2-F)	1	

PL 8 Main Frame Assembly

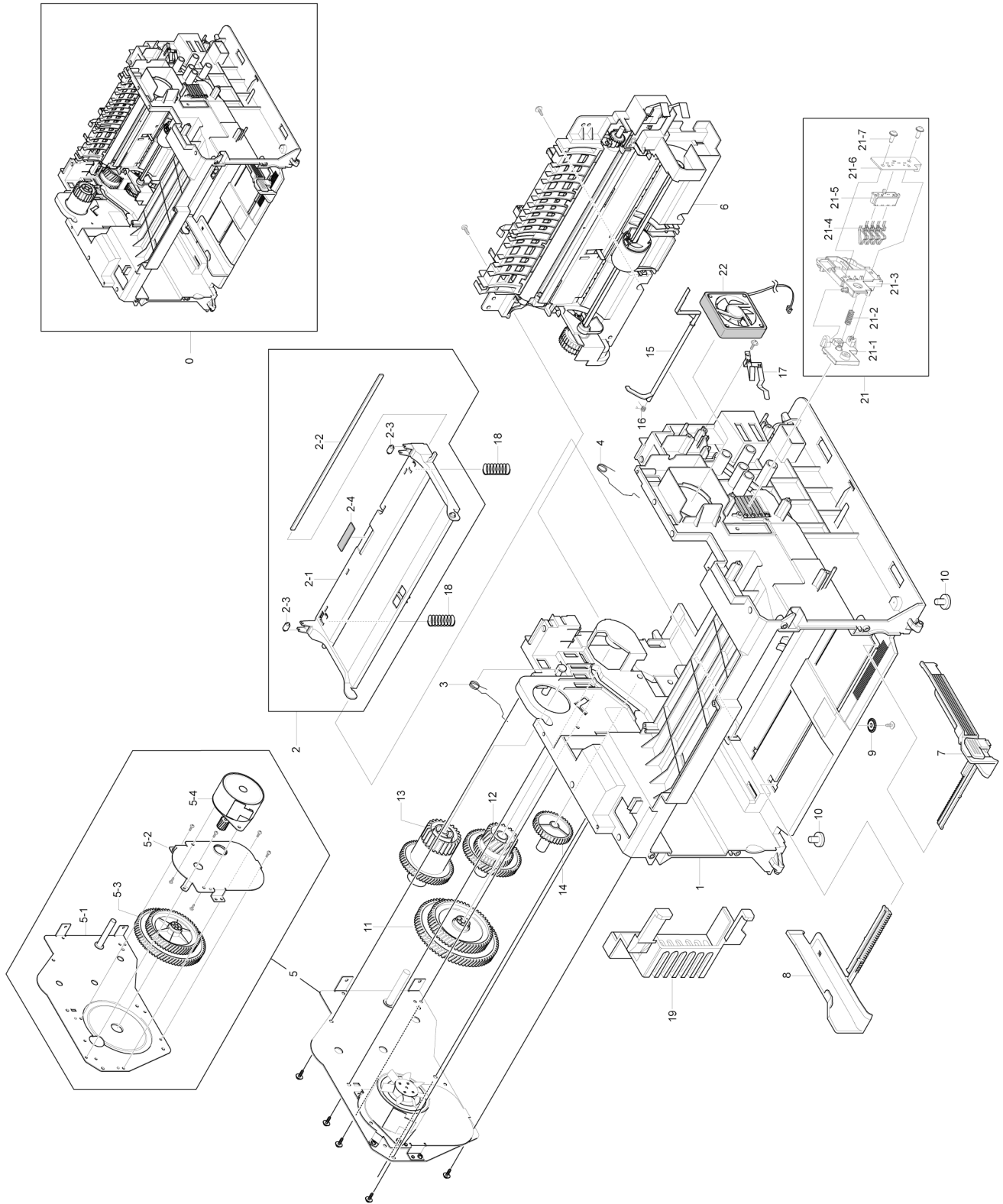

PL 8 Main Frame Assembly

Item	Part Number	Description	Qt'y	Remark
0		ELA HOU-FRAME LOWER	1	
1		FRAME-M-BASE	1	
2	015N00560	MEA UNIT-PLATE KNOCK_UP	1	
2-1	015N00561	PLATE-M-KNOCK_UP	1	
2-2		SHAFT-P-CORE	1	
2-3		PMO-IDLE KNOCK UP MP	2	
2-4	019N00835	MPR-PAD KNOCK UP MR	1	
3	009N01516	SPRING ETC-TORSION DEVE_L	1	
4	009N01517	SPRING ETC-TORSION DEVE_R	1	
5	126N00247	ELA HOU-RX DRIVE	1	
5-1		BRACKET-P-GEAR	1	
5-2		BRACKET-P-MOTOR	1	
5-3		GEAR-RDCN 139/83	1	
5-4	127N07405	MOTOR STEP-MAIN	1	
5-5		PMO-IMPELLER_DRV	1	
6		PAPER PATH ASSEMBLY (REFER TO PL 6)	1	
7	026N00764	ADJUST-M-CASSETTE_R	1	
8	026N00765	ADJUST-M-CASSETTE_L	1	
9	007N01178	GEAR-PINION	1	
10	017N00251	FOOT-FRONT	2	
11	007N01371	GEAR-RDCN 113/83	1	
12	007N01372	GEAR-OPC DR 76/38/29	1	
13	007N01373	GEAR-FUSER DR 63/35	1	
14	007N01374	GEAR-FEED DR 41	1	
15	120N00481	LEVER-M-ACTUATOR_EMPTY	1	
16	009N01513	SPRING ETC-TORSION DOC (CC2-F)	1	
17	115N00857	GROUND-P-OPC	1	
18		NOT USED		
19		CAP-M-MOTOR	1	
20	009N01518	SPRING ETC-CS-CHARGE APOLLO	2	
21		CRUM ASSEMBLY	1	
21-1	003N00973	PLATE-M-HINGE	1	
21-2		SPRING ETD-FEED	1	
21-3	015N00564	PLATE-M-CRUM	1	
21-4		TERMINAL-CRUM	8	
21-5		TERMINAL-M_BLOCK	1	
21-6	140N63043	PBA-CRUM_P	1	
22	127N01453	FAN-DC	1	

PL 9 MP Tray Assembly

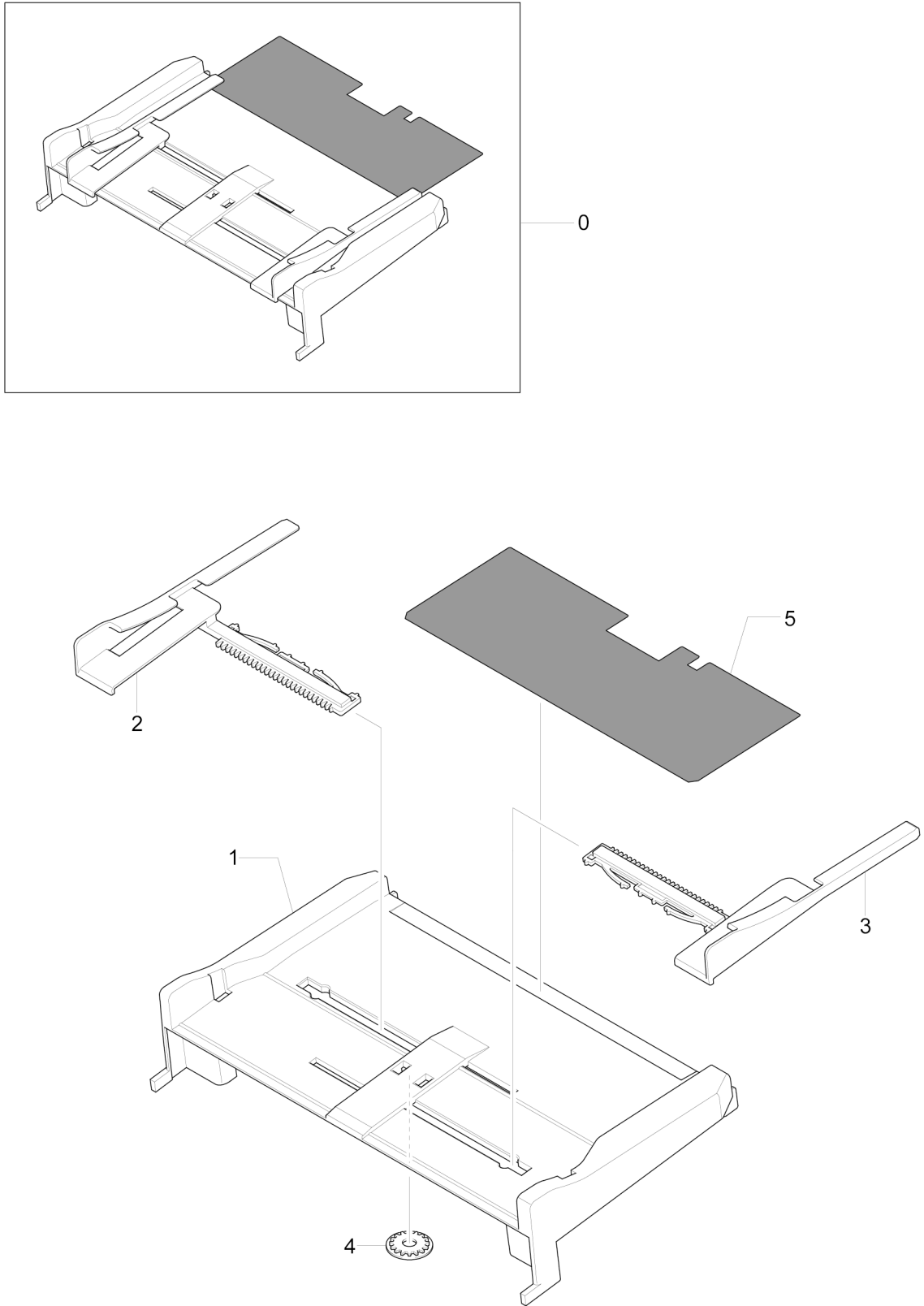

PL 9 MP Tray Assembly

Item	Part Number	Description	Qt'y	Remark
0	050N00478	MEA UNIT-MP TRAY	1	
1	015N00562	PLATE-M_MP	1	
2	026N00766	ADJUST-M_MP L	1	
3	026N00767	ADJUST-M_MP R	1	
4	007N01178	GEAR-PINION	1	
5	002N02451	SHEET-MP	1	

PL 10 Common Hardware & General Service Items

PL 10 Common Hardware & General Service Items

Item	Part Number	Description	Qt'y	Remark
0	026N00768	SCREW TAPTITE	3	
1	026N00769	SCREW TAPTITE	1	
2	105N02072	AC POWER CORD (US VER)	1	
3	117N01620	TELEPHONE LINE CORD (US VER)	1	
4	117N01313	USB CABLE	1	
5	004N00244	CUSHION-MAIN	1	
6	060N00030	BOX(P) MAIN	1	
7	705N00013	CD-ROM DRIVERS	1	
8	705N00012	CD-ROM EUG	1	
9	705N00014	CD-ROM SCANSOFT	1	

6. General Procedures/Information

GP 1 Product Specifications	6-3
GP 2 System Overview	6-11
GP 3 User Mode	6-28
GP 4 Tech Mode and Setting	6-32
GP 5 Control Panel	6-40
GP 6 LCD Status Error Messages	6-41
GP 7 Engine Test Mode	6-43
GP 8 Paper Path and Clearing Paper Jams	6-45
GP 9 General Precautions on Disassembly	6-52
GP 10 Tools	6-53
GP 11 Acronyms and Abbreviations	6-54
GP 12 Selecting printer locations	6-56
GP 13 Sample Test Pattern	6-57
GP 14 Service Log	6-58

Page intentionally blank

GP 1 Product Specifications

Product Overview

Table 1:

Item	Description	Remark
Basic Model	PE220 4 in 1 MFP	
Target User	SOHO, Economical (Speed/Price) Customer	
Customer Benefits (Sales Points)	<ul style="list-style-type: none"> - Compact Size - 20ppm/A4, 20ppm/Letter fastest speed in its price class - Favorite Copy - ID Card Copy - Toner Save 	
Key Specification	<ul style="list-style-type: none"> - up to 20ppm/A4(Up to 20ppm/Letter) - 150 sheets Multi-Purpose type paper input/50 sheets Paper Output - 3,000pages toner capacity - 600dpi Print/Copy Resolution - Xerox Print Language - 16MB System memory - 30 Sheet ADF - 33.6 Kbps Fax Modem - 100 Speed Dial - 72 Hour Battery Back-up 	

Specifications

Product Specifications are subject to change without notice. See below for product specifications.

General Specifications

Table 2:

Item		Description
Major Features		Copier, Print, Scan, Fax
Net Dimension (WxDxH)		438(W)*374(D)*368(H)(17.2x14.7x14.5")
Net Weight (Inc. Print Cartridge)		10.4kg
CPU		Chorus-2 (66MHz)
LCD		2 Line x 16 characters / 2Line x 8 characters (for china and korea)
Toner Save		Yes
I/O Interface		USB1.1 (Compatible with USB 2.0), IEEE 1284 Parallel
Network Interface		No
OS Compatibility		Windows 98/Me/NT4.0/2000/XP, Various Linux OS (via USB interface only) including Red Hat 8.0~9.0, Fedora core 1~3, Mandrake 9.0~10.2, and SuSe 8.2~9.2, Mac 10.3
Power Requirement		110 ~ 127 VAC, 50/60 Hz, 4.5A 220 ~ 240 VAC, 50/60 Hz, 2.5A
Power Consumption		Sleep Mode: Under 10 W Standby Mode: 65W Average: 350 W (Print Mode)
Energy Star Compliant		Yes
Power Switch		Yes
Noise	Warm up Stand by Coping Printing	49 dBA 35 dBA 55 dBA 53 dBA
Warm up time	from Power On Status	Less than 35 seconds
	from Sleep Mode (Recovery time)	Less than 30 seconds
Max. Monthly Volume	Print	4,200 pages
	Scan	ADF: 2,500 pages, PLATEN: 1,700 pages
Average Monthly Print Volume		400 pages
Average Monthly SCAN Volume		150 pages
Machine Life	ENGINE SCANNER	5 years or 50,000 Pages. Whichever comes first ADF: 30,000 Pages, Platen: 20,000 Pages
Operation conditions	Temperature Humidity	10°C ~ 32 °C (50°F ~ 89°F) 20% ~ 80% RH
Approval		Class B
Device Memory		16MB
Page Counter		Yes
Print Configuration Sheet (System Data)		Yes

Print Specifications

Table 3:

Item		Description
Method		Laser Beam Printing
Speed		Up to 20ppm in A4 (20ppm in Letter)
Emulation		GDI
Power Save		Yes (Interval option: 5, 10,15, 30, 45 minute)
Resolution	Normal	600 x 600 dpi
	RET	-
Memory		10MB
First Print Out	From Stand by	Approx. 11 seconds
Time	From Cold Status	Less than 41 seconds
Duplex	Print	-
WHQL Compliant		Window XP
Printable Area		A4: 201.6x288.6mm
		LTR: 207.6x270.6mm
		Legal: 207.6x347.6mm
		Folio: 207.6x322.6mm
Halftone (Gray Scale)		256 levels

Scan Specifications

Table 4:

Item		Description
Compatibility		Twain standard / WIA Standard (Window 2000/XP)
Scan Method		600dpi Colour CIS (Contact Image Sensor) Module
PC Scan Speed Lineart, Halftone		10sec Platen(13sec ADF)
through Platen	Gray	23sec Platen (26sec ADF)
	Color 300dpi	65sec Platen(70sec ADF)
Resolution	Optical	600 x 600 dpi
	Enhanced	4800 x 4800 dpi
Halftone		256 levels
Scan Size	Max. Document Width	Max.216mm (8.5")
	Effective Scan Length	297 mm (11.7")
	Effective Scan Width	Letter/Legal: 208mm(8.2")A4: 202mm
Scan-to	Key	Yes
	Application	Yes
Scan Depth	Color	24 bit
	Mono	1bit for Line art, Halftone, 8 Bit for Gray scale

Copy Specifications

Table 5:

Item		Description
Copy Speed		Up to 20ppm in A4 (20ppm in Letter)
Resolution	Optical	600*600 dpi (Scan:600*600dpi, Print: 600*600dpi) - Text & Text/Photo mode: 600*300dpi(ADF, Platen) - Photo mode: 600*600dpi (Platen), 600*300dpi(ADF)
	Enhanced	-
First Copy Out Time	Stand by	Approx. 16 seconds (ADF), Approx. 11 seconds (Platen)
	From Power Save Mode (110V only)	Approx. 46 seconds (ADF), Approx. 40 seconds (Platen)
Original Image type selection		Text, Text/Photo, Photo
Zoom Range		25-400%(Platen), 25-100%(ADF)
Multi Copy		1~99 Pages
Preset		[Original(100%)], [A4 to A5(71%)], [LGL to LTR(78%)], [LGL 4(83%)], A4 to LTR(94%), [EXE to LTR(104%)], A5 to A4 (141%), 25%, 50%, 150%, 200%, 400%, [Custom: 25-400%]
Darkness Control		3 level (Light, Normal, Dark)
Auto return to default mode		Yes (after 1 minute)- Time out option: 15, 30, 60, 180 sec., Off
Changeable Default mode		Darkness, Original Type, Reduce/Enlarge, No. of Copies
ID Card Copy	2-up	Yes (ADF Only)
	4-up	Yes (ADF Only)
	Collation	Yes (ADF Only)
	Autofit	Yes (Platen Only)
	LD Card Copy	Yes (Platen Only)
	Clone	Yes (Platen Only)
	Poster	Yes (Platen Only)

Telephone Specifications

Table 6:

Item		Description
Handset		No
Manual Dial		Yes
Search		Yes (Phone Book)
1-Touch Dial		10 ea (0~9)
Speed dial		90 locations(10~99)
TAD I/F		Yes
Tone/Pulse		Tone - Default, Pulse - Changing in Tech Mode
Pause		Yes
Auto Redial		Yes
Last Number Redial		Yes
Distinctive Ring		Yes
Caller ID		No
Extension Phone Interface		Yes
Report & List	Tx/Rx Journal	Yes
Print out	Confirmation	Yes
	Help List	No
	Auto Dial List	Yes
	System Data	List all user setting
Sound Control	Ring Volume	Yes (Off,Low,MED,HIGH)
	Key Volume	Yes (On,Off)
	Alarm Volume	Yes (On,Off)
	Speaker	Yes (On,Off, Comm)

Fax Specifications

Table 7:

Item		Description
Compatibility		ITU-T G3
Modem Speed		33.6Kbps
TX Speed		3sec
Compression		MH/MR/MMR/JPEG
Color Fax		Yes (Tx Only)
ECM		Yes
Resolution	Std	203*98dpi
	Fine	203*196dpi
	S.Fine	300*300dpi
	Photo	203*196dpi
	Color	200*200dpi
	Auto Switching	Yes
Scan Speed	Standard	approx. 3sec (ADF)
		approx. 5sec (Platen)
	Fine	approx. 7sec (ADF)
		approx. 8sec (Platen)
	S.Fine	approx. 7sec (ADF)
		approx. 8sec (Platen)
Rx fax duplex print out		No
Multiple page scan speed (Memory Tx.)		7 cpm / Ltr (Standard Resolution Res.)
Receive Mode		Fax, TEL, Ans/Fax, DRPD
Memory	Capacity	2MB (When Power off Memory Back up)
	Optional Memory	No
	Max locations to store to 1 Group Dial	99 locations
	Fax Forward	Yes (On/Off)
	Broadcasting	109 locations (Max locations)
	Cover page	NO
	Delayed fax	Yes
	Memory RX	Yes
Functions	Voice Request	No
	TTI	Yes
	RTI	Yes
	Polling	No
	Earth/Recall	No
	Auto Reduction	Yes
	RDS	Yes
Junk Fax barrier		Yes
Security Receive		Yes
Memory Back-up		Max. 72hours

Paper Handling Specifications

Table 8:

Item	Description
Input Capacity and Types	150-sheet Cassette Tray (75 g/m ² , 20 lbs)
Output Capacity and Types	50-sheet Face Down, (75 g/m ² , 20 lbs)
Manual Tray	1 sheet
Media size	A4, A5, A6, Letter, Legal, Folio, Executive, ISO B5, JIS B5, Monarch, Envelope, No.10, DL, C5, C6 76 x 127 mm (3" x 5") ~ 216 x 356 mm (8.5" x 14")
Media Type	Plain Paper, Transparency, Label, Envelope, Tick, Thin, Bond, Color Paper, Card Stock, Preprinted
Paper Weight	16~24lb (60 to 90g/m ²) for 150 sheets, Cassette Tray 16~43lb (60 to 165g/m ²) for 1 sheet, Manual Tray
ADF Capacity	Up to 30 sheets of 20lb(75g/m ²) paper
ADF Document Size	Up to Legal

Software

Table 9:

Item	Description	
Compatibility	DOS	No
	Win 3.x	No
	Win 95	No
	Win 98/ME	Yes
	Win NT 4.0	Yes
	Win 2000	Yes
	Win XP	Yes
	Mac	Yes (10.3)
	Linux	Yes
Driver	Printer	GDI
	TWAIN	Yes
	WIA	Yes
	ScanToPC	Yes
	PC-FAX	Yes (Send only)
Application	RCP	Yes
	Status monitor	No
	SmarThru4	Yes

Accessories

Table 10:

Item	Description
Quick Start Guide	Yes (some countries)
S/W CD ROM	1CD (contents: Print driver, Twain driver, RCP) 2CD (Electronic User Manual) 3CD (ScanSoft CD)
Print Cartridge	1 EA
Power Cable	1 EA
Telephone Cord	1 EA
Printer Cable	USB
Tray Cover	Yes

Consumables

Table 11:

Item	Description
Type	Single Cartridge
How to install	Front door open and front loading
Toner Yield	3,000 pages at ISO 19752 5% Coverage (ships with 1,000 pages Starter print cartridge)
Code	PE220
Level Sensor	-

GP 2 System Overview

System Layout

Main Control, Operation Panel, Scanner, Line Interface and Power supply. Each component is modular with focus on common and standard design of different products. Main control adopting Fax & LBP Printer exclusive Controller is chorus2 CPU(ASIC) and 1 Board. Scanner is composed of ADF and Platen and is connected with Main by Harness.

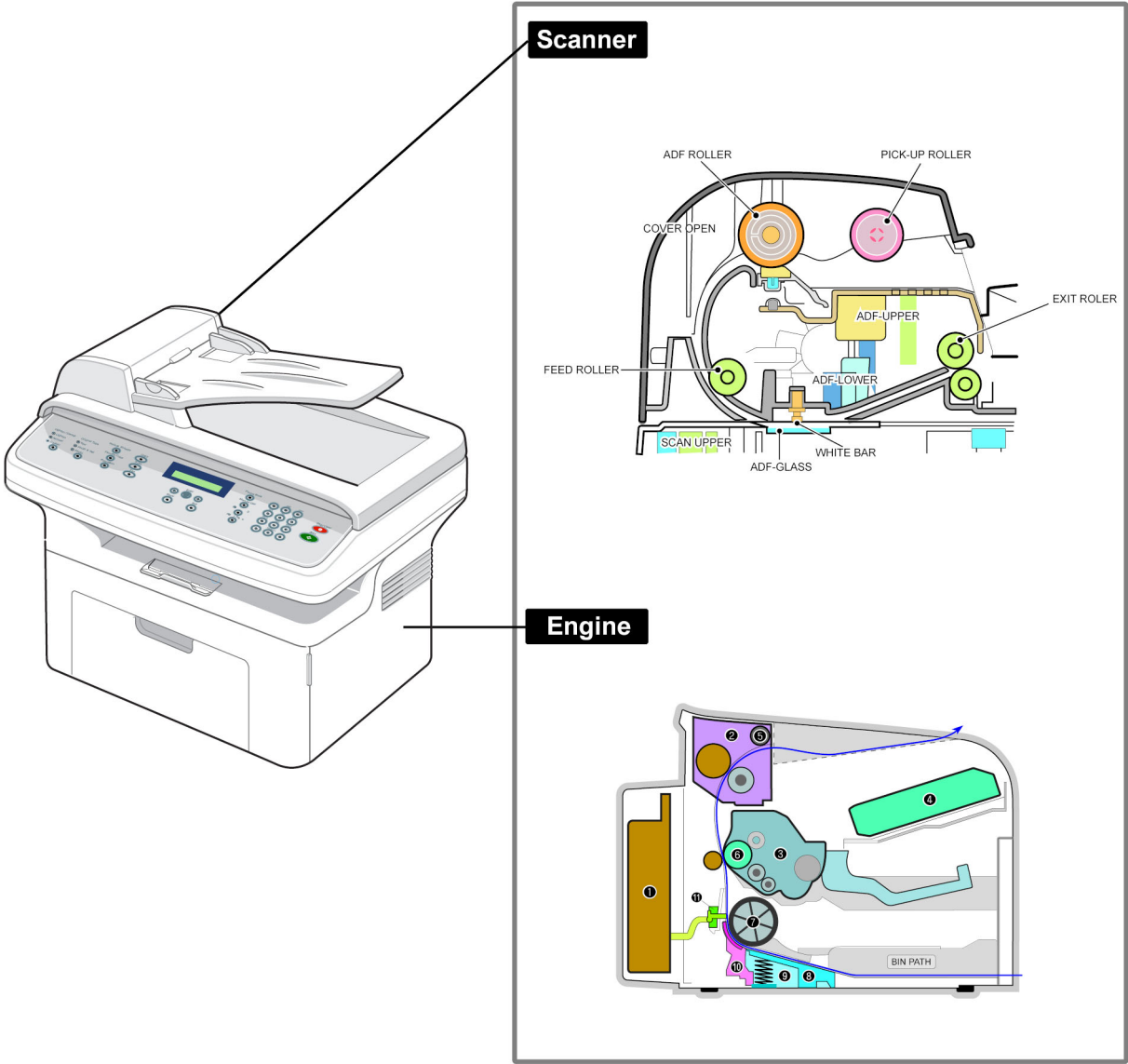

Figure 1

Feeding section

There is a universal cassette which automatically loads paper and the manual feed which supplies paper single sheet at a time. The cassette has a friction pad which separates paper to ensure single sheet feeding, and it has a sensor, which checks when the paper tray is empty.

- Feeding Method: MP Cassette Type
- Feeding Standard: Center Loading
- Feeding Capacity: Cassette-150 sheets (75g/m², 20lb paper standard)
Manual-1sheet (Paper, OHP, Envelop, etc.)
- Paper detecting sensor: Photo sensor
- Paper size sensor: None

Transfer Assembly

This consists of the PTL (pre-transfer lamp) and the Transfer Roller. The PTL shines a light onto the OPC drum. This lowers the charge on the drum's surface and improves transfer efficiency. The transfer roller transfers toner from the OPC drum surface to the paper.

- Life expectancy: Over 50,000 sheets (at 16~30°C)

Driver Assembly

- Gear driven power unit. The motor supplies power to the paper feed unit, the fuser unit, and the print cartridge.

Fixing Part (Fuser)

- The fuser consists of the Heat Lamp, Heat Roller, Pressure Roller, Thermistor, and Thermostat. It fixes toner to the paper using pressure and heat to complete the printing job.

Temperature-Intercepting Device (Thermostat)

The thermostat is a temperature sensing device, which cuts off the power to the heat lamp to prevent overheating fire when the heat lamp or heat roller overheats.

Temperature Detecting Sensor (Thermistor)

The Thermistor detects the surface temperature of the heat roller, this information is sent to the main processor which uses this information to regulate the temperature of the heat roller.

Heat Roller

The surface of the Heat Roller is heated by the Heat Lamp. As the paper passes between the Heat and Pressure rollers the toner is melted and fixed permanently to the paper. The surface of the roller is coated with Teflon. This ensures that toner does not adhere to the roller surface.

Pressure roller

The Pressure Roller mounted under the heat roller is made of a silicon resin and the surface of the roller is coated with Teflon. This ensures that toner does not adhere to the roller surface.

Safety Features

To prevent overheating

- 1st protection device: Hardware cuts off when overheated
- 2nd protection device: Software cuts off when overheated
- 3rd protection device: Thermostat cuts off mains power to the lamp.

Safety device

- Fuser power is cut off when the front cover is opened
- LSU power is cut off when the front cover is opened
- The temperature of the fuser cover's surface is maintained at less than 80°C to protect the user and a caution label is attached where the customer can see it easily when the rear cover is opened.

Covers

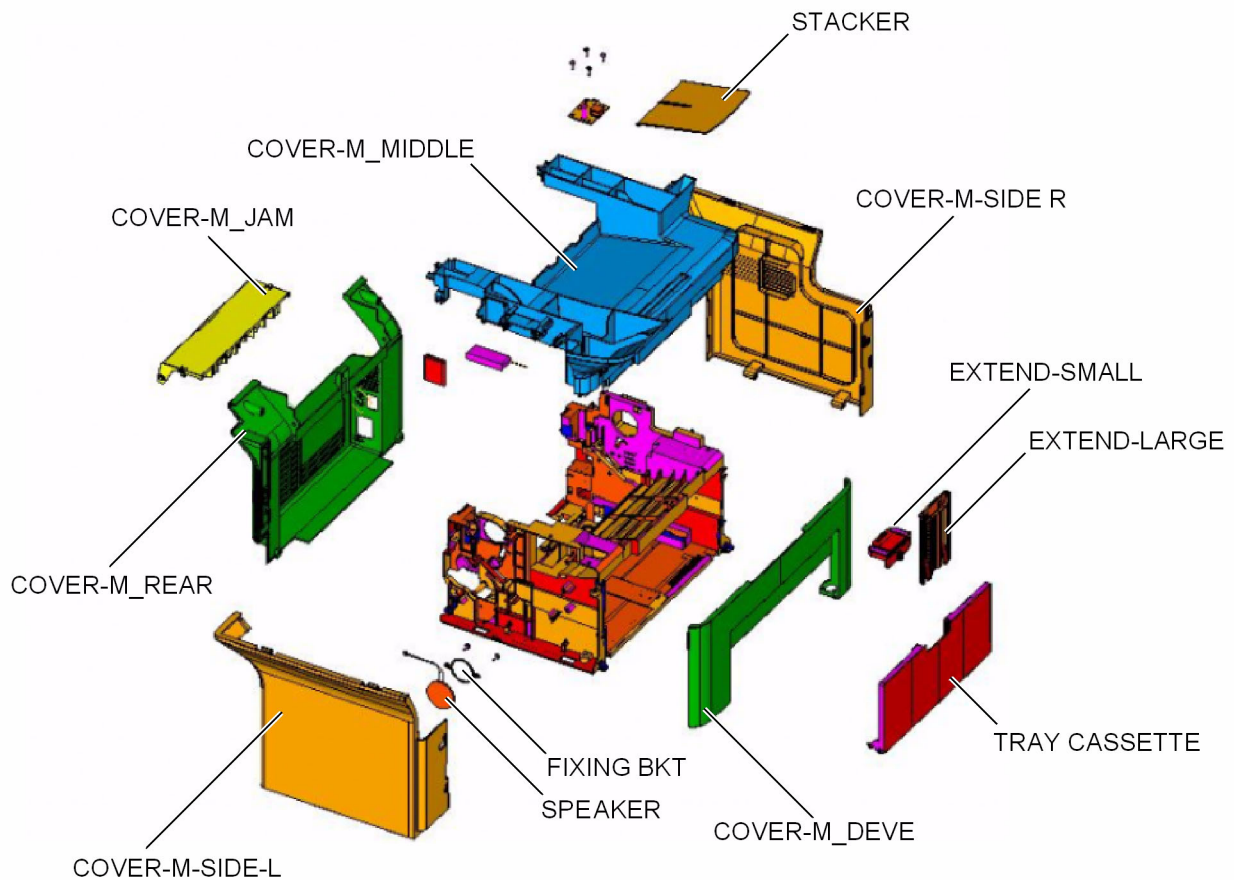

Figure 1

Scanner

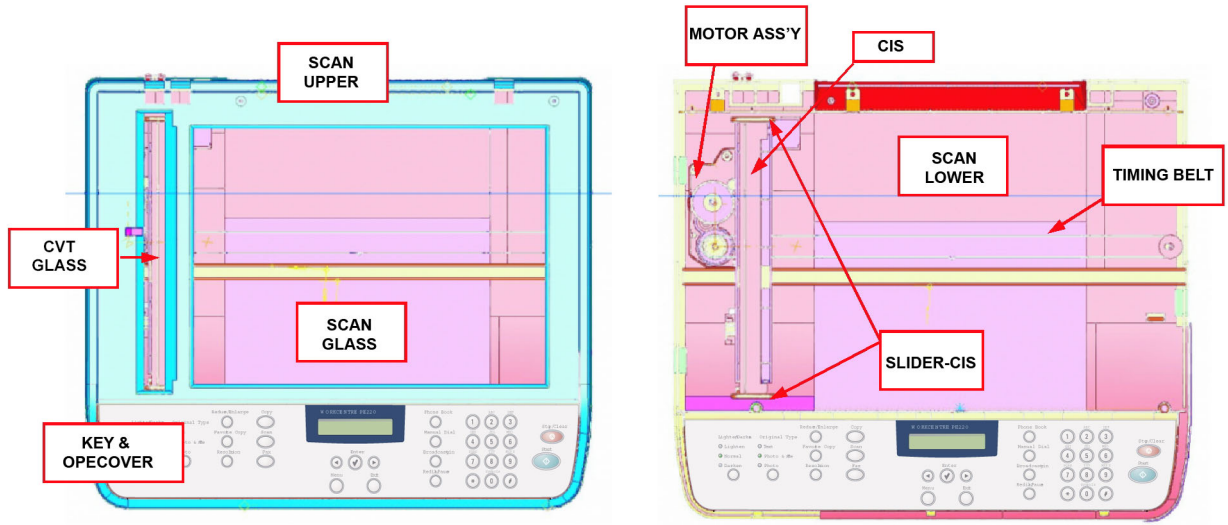

Figure 2

Engine H/W Specification

- 1) Printing Method: LSU (Laser Scanning Unit)
- 2) Printing Speed: 20ppm
(In continuing printing base Letter, printing pages from 2nd to last during 1min)
- 3) Printing Resolution: 600 dpi
- 4) Cassette Capa.: Cassette; 150sheets(75g/ Base), 1-sheet Feeding: Paper, OHP, Envelop - 1 sheet
- 5) Manual Tray: All paper 1 sheet
- 6) Paper Size: Cassette,Manual; Width = 76 ~ 216mm (2.99 ~ 8.05in) , Length = 125mm ~ 356mm (4.92 ~ 14.02in)
- 7) Effective printing size
 - A4:202 x 291 mm (7.95 x 11.46in)
 - Letter:208 x273mm (8.19 x 10.75in)
 - Legal: 208 x 350 mm (8.19 x 13.78in)
 - Folio: 208 x 325 mm (8.19 x 12.8in)
 - Top Margin: 2.2 mm (0.09in)
 - Left, Right Margin: 2.2 mm (0.09in)
- 8) CRU (Print Cartridge) Life: 3,000pages Printing(A4, ISO 5% Pattern Printing)
- 9) First Print Out Time: within 11sec (Standby)
- 10) Warming up time: within 35sec (Ambient: 25 °C)

Main Board Control

Main control is made of ASIC(CPU, Image processor, PC I/F part include, Scan interface part, FAX Modem part and Printing process I/F part. CPU handles the BUS control, I/O interface, scan interface, PC interface and other miscellaneous driver circuit.

1) Main Board

- Main Board has a function of sending Current Image Video Data to LSU of the machine, controlling motor

Driving Circuit and monitoring Paper Exit Sensor, Cover Open switch, OPE Panel Inputs.

2) Main Controller

- CPU: Chorus2 is the main CPU and is made up on the 16/32bit RISC architecture using ARM7TDMI core. Main CPU controls the whole system according to the program code which stored in the Flash-ROM memory.

- Summary of the Key Function Block:

- 1.8V for internal Core, 3.3V for I/O Pad with 4KByte Cache.
- Image Processor included.
- On-Chip clock generator with PLL.
- Memory and External Bank Control.
- DMA Control (5-Channel)
- Interrupt Control.
- 2-port USB Host/1-port USB device (ver 1.1) interface control.

- Parallel interface control.
- UART(2-Channel)
- Synchronous Serial Interface Control.
- A/D Converter(10-bit, 2channel).
- General I/O Port control.
- Tone Generator.
- RTC with calendar function.
- S/W Assistant function (Rotator)

- Flash Memory: Stores system program and can be updated to the newer system program code through the PC interface. It stores the FAX Journal List, One Touch dial number, speed dial number, and machine configuration setup data.

- Capacity: 2 Mbyte
- Access Time: 70 nsec

- SDRAM: SDRAM is used for Print Buffer, Scan buffer when scanning, ECM Buffer when FAX Receiving, and system working memory.

- Capacity: 16 Mbyte
- Access Time: 66MHz based on system bus clock.
- Data Backup: 72 Hours
- Backup Battery Charging Time: 100hours when completely discharged.

Scanner

1) Image Signal Input

- Image Signal from CIS has a level of about 1.2V and is goes to ADC of Chorus2. After ADC, CIS analog signal will be converted to 8-bit Digital signal.

2) Image Processing

- On the surface of the original paper, the light from the CIS LED reflected and goes to the CIS Sensor.

Then the light is converted to the appropriate voltage suitable for ADC input. Analog signal from CIS sensor is used for ADC input then is converted to 8-bit digital data. Image processor of the Chorus2 will do the Shading correction function at first, then Gamma correction function next. After then, the data goes to different module according to the copy or FAX resolution mode. When Text mode, the image data goes to LAT module, when Photo mode, the image data goes to Error Diffusion module, when PC-Scan mode, the image data goes directly to the PC through DMA access.

- Summary of the Image sensor interface is as below;
 - Minimum Scan Line Time:1.5ms
 - Scan Resolution: 600*600 dpi
 - Scan Width: 208mm
 - Function
 - White Shading Correction
 - Gamma Correction
 - CIS Interface

- 256 Gray Scale

3) CIS Driving

- CIS Supply Voltage: +3.3V
- CIS Max frequency: 5MHz
- CIS Linetime
 - Fax/Copy - 1.5ms
 - PC-Scan - 4.5ms
- White output volt.: Max 0.8V

4) ADF Driving: Driving ADF Stepper motor, and the maximum motor speed is 2000PPS.

- MOTOR DRIVER: A3978(Allegro)
- Driving Voltage: 24V DC
- Phase: 2-2 Phase 2000PPS at Quick Scan,
2-2 Phase 1000PPS AT Fine Scan,
2-2 Phase 667PPS AT Super Fine Scan

Fax Modem

1) Modem

The modem consists of FM336 (FAX Modem chip), LIU (Line Interface Unit) and modem analog front end (AFE) functional part.

- The feature of the FM336 modem chip is as below;
 - 1 Communication Mode: Half Duplex
 - 2 Modem Method
 - GROUP 3: ITU-T V34, V17, V29, V27ter
 - Tonal Signal: ITU-T T.30
 - Binary Signal: ITU-T V.21, T.30
 - 3 Image Transmission Time: 3sec (ITU-T NO.1 CHART/Memory Tx/ECM)
 - 4 Data Compress: MH, MR, MMR, JPEG
 - 5 Modem Speed: 33600 / 28800 / 14400 / 12000 / 9600 / 7200 / 4800 / 2400 bps
 - 6 Receive Level: 0 ~ -48dBm
 - 7 Output Level
 - Adjustable: -6 ~ -15dBm (1dBm Step)
 - Initial Setting: -12dBm
 - 8 Receive dynamic range:
 - 0 dBm to -43 dBm for V.17, V.29, V.27 ter and V.21
 - -9 dBm to -43 dBm for V.34 halfduplex

2) The Gain of the Line signal can be adjusted by setting the register value of the FAX modem chip, Tx and Rx path and is almost directly connected to the impedance matching transformer of the LIU.

- Adjust Tx Level within Setting Level+0,-2dB range.
- Adjust Rx Level that has the same level as the TIMS out level if possible, and must not

exceed the TIMS out level.

3) Speaker Driving Unit

Analog Switch(MC14053BD) makes a path for FAX Tone, Ring, Key click sound and Analog MUX (MC14051) makes a different signal level so that the Speaker driver chip(MC34119) can drive the Speaker with different sound volume.

Printing Process

Printing Process part is made of PC-Interface part, PVC (Printer Video Controller), LSU control part, High Voltage control part and Fuser Unit control part. PC-interface core is included in the Chorus2 ASIC and controls the PC interface. LSU control part controls the LSU polygon motor, Laser diode, video data output so that the printing image can be made up on the OPC Drum.

Line Interface

Line interface part helps the machine connect to the PSTN or PABX Line and is made of almost primary circuit. Its main function is Line connection, Line state monitoring and TAD interface that enables a extension telephone or TAD machine to connect to the machine.

Engine Paper Feeding

- 1) Feeding Type: MP Cassette Type
- 2) Feeding Standard: Centre Loading
- 3) Feeding Qty: Cassette 150 sheets (75g/, 20lb paper standard)
- 4) 1 sheet (Paper, OHP, Envelope etc.)
- 5) Separating Type: Cassette - Friction Pad Type
- 6) Manual Tray: 1 sheet LD Driver circuit
- 7) Driver Type: Driving by Gearing from Main Motor
- 8) Pick_up Roller Driver: Solenoid
- 9) Pick up Roller Rubber Material: EPDM+IR =1.3 or more LD (Laser Diode)
- 10) Pick up Velocity: 94.8731mm/Sec (Process: 93.0667mm/sec)
- 11) Paper detecting Sensor: Photo Sensor
- 12) Paper Size Sensor: None
- 13) Paper Separating Pad Material: NBB 52 °, =0.8~1.2
- 14) Separating Pad Pressure: TBD 150 gf
- 15) Pick_up Roller RPM: 47.683 RPM
- 16) Feeding Pressure (Same as Transfer Roller)
- 17) Paper Exit Type: Face Down
- 18) Feed Roller Force: TBD Kg.f or more.
- 19) Spring Feed Tensile Force: TBD gf
- 20) Feed roller Velocity: mm/sec
- 21) Feed Roller Material
- 22) Exit Sensor: Photo Sensor

LSU

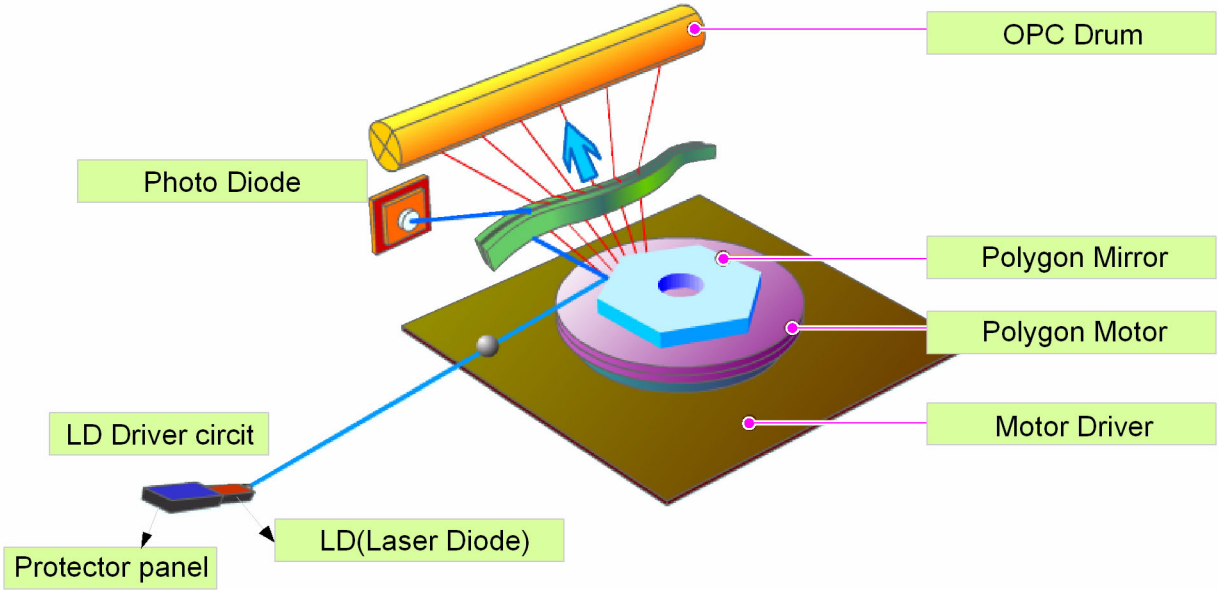

Figure 1

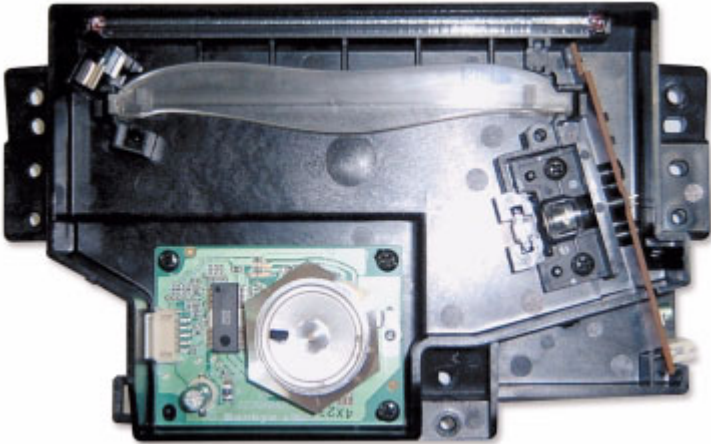

Figure 2

Developer Process

- Developing Method: Non magnetic 1 element contacting method
- Toner: Non magnetic 1 element shatter type toner
- Toner Qty:35gf /60gf (1k/3k)
- The life span of toner 1k/3k sheets (ISO 5% Coverage)
- Toner Residual Sensor: None
- OPC Cleaning: Use the conventional cleaning blade
- OPC Drum Protecting Shutter: None
- Classifying device for print cartridge: ID is classified by interruption of the frame channel.
- Development Roller type: conductive elastic roller
- Doctor BLADE Type: Regulating toner layer by pressure
- Charge Roller Type: Conductive Roller Contact-Charge

Fuser Specification

1) Heat Lamp

- Heat Lamp Terminal Shape: Terminal Single Type
- Voltage 120 V: $115 \pm 5 \%$, 220 V: $230 \pm 5 \%$
- Capacity: 600 Watt ± 30 W
- Light Qty Distribution: 140%
- Life: 3000 Hr

2) Thermostat

- Thermostat Type: Non-Contact type THERMOSTAT
- Control Temperature: 150°C

3) Thermistor

- Thermistor Type: HF-R0060 (SEMITEC 364FL Type)
- Temperature Resistance: 7 k Ω (180 °C)
- SYSTEM Temperature SETTING
 - Stand by: $165 \pm 5^\circ\text{C}$
 - Printing: $175 \pm 5^\circ\text{C}$ (5 minutes before)
 $170^\circ\text{C} \pm 5^\circ\text{C}$ (5 minutes before)
 - Overshoot: 200°C or less
 - Overheat:210°C or less

4) Safety Relevant Facts

- Protecting device when overheating
 - 1st protecting device: H/W cuts off when detecting an overheating
 - 2nd protecting device: S/W cuts off when detecting overheating
 - 3rd protecting device: Thermostat cuts off the power
- Safety device
 - The power of Fuser is cut-off after front cover is open.
 - The overheating safety device for customer
 - The surface temperature of the Fuser Cover is under 80°C

Scanner

600dpi Color CIS Module for Flat bed, uses the CIS scanning method

1) CIS SPEC

- Scanning size: 216 mm (width for letter-size)
- Light source: LED
- Scanning sensor: CIS 600/300 dpi
- Scanning mode: Color SCAN / Mono SCAN
- MTF: 30% (300 dpi Chart)
- CIS interface: Analog output
- Power supply: 3.3V
- Clock Frequency: 5MHz max.
- Number of output: 1
- LED Current: Red/Green/Blue: 60mA
- Clamp Level: 1.1V
- Connection: 12 pin FFC connector (pitch 1.0mm)

2) Scan Resolution

(a) Transmission

- Normal: Vertical: 3.85 Line/mm, Horizontal: 8 Pels/mm:203 x 98dpi
- Fine: Vertical: 7.7 Line/mm, Horizontal: 8 Pels/mm:203 x 196dpi
- Super Fine: Vertical: 11.8 Line/mm, Horizontal: 11.8 Pels/mm ;300 x 300dpi

- #### (b) When Copy: Vertical: 11.8 Line/mm, Horizontal: 23.6 Pels/mm :600x300dpi(ADF) Vertical: 23.6 Line/mm, Horizontal: 23.6 Pels/mm :600x600dpi(Platen)

3) Half Tone (Gray Scale): 256 Levels

4) Scan Line Time

(a) Tx

- Normal: 1.5 ms/Line
- Fine: 1.5 ms/Line
- Super Fine: 1.5 ms/Line

(b) Copy: 1.5 ms/Line

(c) Scan

- Color: 4.5msec/line
- Gray: 4.5msec/line
- Mono: 4.5msec/line

5) Scanning Width

- MAX SCAN WIDTH: 216 mm (8.5 inches)
- Effective Scan Width: 208mm (8.19 inches)

6) ADF Motor

(a) Motor Spec

- 24VDC
- 0.6A(Peak)

7) Motor Driver speed & method

- (a) FAX Transmission
 - Normal Mode: 2000 pps
 - Fine Mode: 1000 pps
 - Super Fine Mode: 667 pps
- (b) Copy Job: 667 pps, 2-2
 - max(30sheets): 50gf
 - min(1sheets): 20gf

8) Document Detect sensor

- (a) Type: Photo interrupt
- (b) Position: ADF PBA
- (c) LED - max current: 50mA
 - max voltage: 3.3V
- (d) Output - Logic "H": No Paper
 - Logic "L": Paper
- (e) Lever-Sensor DOC: ADF Lower Torsion Spring

9) Regi Detect sensor

- (a) Type: Photo interrupt
- (b) Position: ADF PBA
- (c) LED - max current: 50mA
 - max voltage: 3.3V
- (d) Output - Logic "H": No Paper
 - Logic "L": Paper
- (e) Lever-Sensor DOC: ADF Lower Torsion Spring

10) Document Scan sensor

- (a) Type: Photo interrupt
- (b) Position: ADF PBA
- (c) LED: - Max current: 50mA
 - Max Voltage: 3.3V
- (d) Output - Logic "H": Off (No Position), No Paper
 - Logic "L": On (Doc Position), Paper
- (e) LEVER - SENSOR SCAN: Scan Lower Torsion Spring

OPE (Operational Panel Equipment)

1) OPE Panel

OPE Panel has a MICOM Chip on it and communicates with Main CPU using Serial communication Line (SIO). OPE Panel consists of Micom, Key Matrix Part, LED Driving Part and LCD Part.

2) Key Description

Table 1:

No	Part	Feature	Function
1	Common	3*4Key	Dialling and Option Input
		Start	
		Stop/Clear	
		Menu Option select	
		Upper Level Return to upper level menu	
		Enter Option select/ Execute	
		Next menu or Next option item	
		Previous menu or Previous option item	
2	Save	Toner Save	TONER SAVE MODE select
3	Copy	Reduce/Enlarge	Select ZOOM ratio when copy
		No.of Copies	Select the number of copies
		Original Type	Change Copy Modes (Text,Text/Photo,Photo)
		Darkness	Change the Darkness of the Copied image (Light/Normal/Dark)
		Favourite Copy	Select one of the predefined Copy templates.
4	Fax		STANDARD>FINE>SUPER FINE>PHOTO>COLOR
		Phone Book	Search the user defined Phone number.
		Broadcasting	When sending FAX data to many place in the same time.
		Manual Dial	Manual Dial
		Redial / Pause	Last number Redial / Pause
5	Scan	Scan to	select [scan to PC], [scan to FAX], [scan to E-mail] function

3) LCD Part

- Number of Characters: 16 Characters x 2 line

- Clock, Date display
- System Status display
- Alarm, Error Message display
- Function Dialog Message display

SMPS & HVPS

It is the power supply for the entire system. It is assembled as an independent module, so it is possible to use for common use. It is mounted at back of the machine. Power part is divided by two independent PBAs - SMPS PBA and HVPS PBA. SMPS PBA supplies the DC power for driving the system and supplies the AC power to the fuser.

SMPS has two output channels: +5V and +24V. HVPS PBA supplies High voltage to the developer part to make a printing image on the paper. High voltages applied to the MHV, THV, DEV, SUPPLY.

SMPS

1) AC Input

- Input Rated Voltage: AC 220V ~ 240V / AC 110V ~ 127V
 - Input Voltage fluctuating range: AC 180V ~ 270V / AC 100V ~ 135V
 - Rated Frequency: 50/60 Hz
 - Frequency fluctuating range: 47 ~ 63 Hz
 - Input Current: Under 4.0Arms / 2.5Arms
- (But, the status when lamp is off or rated voltage is inputted/outputted)

2) Rated Output Power

Table 2:

NO	Items	CH1	CH2	Remarks
1	CHANNEL	+5V	+24.0V	
2	CONNECTOR PIN	CON 2 5V PIN: #5pin GND PIN: #6pin	CON 2 24V PIN: #2, #3, #4 GND PIN: #7pin	Jam cover switch included
3	Rated Output	+5V ± 5%(4.75 ~ 5.25V)	+24V -10%/+15%(21.6V ~ 27.6V)	
4	Max. Output current	0.8 A	2.5 A	
5	Peak Loading current	1.0 A	2.7 A	within 1ms Duration
6	RIPPLE NOISE	100mVp-p or less	500mVp-p or less	
7	Maximum output	2.5W	36W	
8	Peak output	4W	55.2W	1ms
9	Protection for loading shortage and overflowing current	Fuse Protection or Shut-down within 1.5A ~ 3.0A range.	Fuse Protection or Shut-down within 3.5A ~ 4.5A range.	

3) Consumption Power

Table 3:

NO	Items	CH1(+5V)	CH2(24V)	System
1	Stand-By	0.6 A	1.3 A	AVG: 65Wh
2	Printing	0.8 A	1.9 A	AVG: 350Wh
3	Sleep-Mode	0.5 A	0.3 A	AVG: 10Wh

4) Power Cord Length: 1830 +/- 50mm

5) Power Cord Switch: Exist

6) Feature

- Withstand Resistance: 100 or more (at DC 500V)
- Insulating revisiting pressure: Must be no problem within 1 min. (at1000Vac,10mA)
- Leaking Current: under 3.5mA
- Running Current: under 40A PEAK (AT 25 °C (77 °F), COLDSTART)
under 50A PEAK (In other conditions)
- Rising Time: within 2Sec
- FallingTime: over 20ms
- Surge: Ring Wave 6KV-500A (Normal, Common)

7) Environment Condition

- Operating temperature range: 0 °C ~ 40 °C (32 °F ~ 104 °F)
- Maintaining temperature range: -20 °C ~ 40 °C (68 °F ~ 104 °F)
- Preserving Humidity Condition: 10% ~ 90% RH
- Operating atmospheric pressure range: 1atm

8) EMI Requirement: CISPR, FCC, CE, MIC,

9) Safety Requirement: IEC950 UL1950, CSA950, C-UL, Semko, EK, CB, CCC(CCIB),GOST, EPA,

HVPS Board

The HVPS board creates the high voltage of THV/MHV/Supply/Dev and supplies them to the development system for making best quality printing image. The HVPS part takes the 24V and outputs the high voltage such as THV/MHV/Supply/Dev, and the outputted high voltage is supplied to the toner, OPC cartridge, and transfer roller.

(a) Transfer High Voltage (THV+)

- Input Voltage: 24 V DC +15% / -10% (21.6V~27.6V)
- Out Voltage: +1300KV 1.5% (200 Load)
- Out Voltage Trigger: 6.5
- Input Voltage Variation: 5%
Load Variation: 5%
- Out Voltage Rising Time: 100 ms Max
- Out Voltage Falling Time: 100 ms Max

- Transfer Variation Voltage on Environment Variation: +500 V ~ +5000V
- Control Method on environment: THV-PWM ACTIVE, transfer Active signal, of environment sensing voltage is input and get feed back current, and recalculate it to resistance.
- Control method on transfer output voltage: It is controlled by changing its duty of THVPWM Signal as follows. 10% Duty: +500V, 90% Duty: +5000V

(b) Charge Voltage (MHV)

- Input Voltage: 24 V DC +15% / -10% (21.6V~27.6V)
- Out Voltage: -1300KV 50V(50 Load)
- Out Voltage Rising Time: 50 ms Max
- Out Voltage Falling Time: 50msMax
- Out Voltage Range: 30 ~ 1000
- Output Control Signal (MHV-PWM): Active Low PWM signal for controlling MHV

(c) Developing Voltage (DEV)

- Input Voltage: 24V DC +15% / -10% (21.6V~27.6V)
- Output Voltage: -350V 20V (50 Load)
- Output Voltage Fluctuation range: PWM Control
- Input contrast of the output stability degree: 5% or less
- Loading contrast: 5% or less
- Output Voltage Rising Time: 50 ms Max
- Output Voltage Falling Time: 50 ms Max
- Output Loading range: 10 ~1000
- Output Control Signal (BIAS-PWM): Active Low PWM signal for controlling MHV

(d) Supply

- Output Voltage: -550V 50V(50 Load)
- Input contrast of the output stability degree: under 5%
- Loading contrast: 5% or less
- Output Voltage Rising Time: 50 ms Max
- Output Voltage Falling Time: 50 ms Max
- Output Loading range: 10 ~ 1000
- Output Control Signal (BIAS-PWM): Active Low PWM signal for controlling MHV

Fuser AC Power Control

The Fuser (HEAT LAMP) gets heat from AC power. The AC power controls the switch with the Triac, a semiconductor switch. The 'ON/OFF control' is operated when the gate of the Triac is turned on/off by Phototriac. In other words, the AC control part is a passive circuit, so it turns the heater on/off with taking signal from engine control part.

When the 'HEATERON' signal is turned on at engine, the LED of PC102 (Photo Triac) takes the voltage and flashes. From the flashing light, the Triac part (light receiving part) takes the voltage and the voltage is supplied to the gate of Triac and flows into the Triac. As a result, the AC current flows in the heat lamp, and heat is occurred.

On the other hand, when the signal is off, the PC102 is off, the voltage is cut off at the gate of Triac, the Triac becomes off, and then the heat lamp is turned off.

1) Triac feature: 12A, 600V SWITCHING

2) Phototriac Coupler (PC102)

- Turn On If Current: 15mA~50mA(Design: 16mA)
- High Repetitive Peak Off State Voltage: Min 600V

GP 3 User Mode

Table 1 below shows the map of User settings available in User Mode. These are fully described in the User Guide and are not included here.

Table 1:

1st level			2nd level	3rd level	Default Value
RETURN ◀--			RETURN		
left/right && Enter --▶		14 character	left/right && Enter		
1. Paper Setting ◀ Paper Type ▶	1	Paper Type	Plain Paper, Bond, Transparency, Cardstock, Labels, Preprinted, Colored, Envelope, Thick, Thin		Plain Paper
	2		Letter, A4, Legal, Executive, Folio, A5, B5, A6		By Country
2. Machine Setup ◀ Machine ID ▶	1	Machine ID	Fax: ID:		
	2	Date & Time	00-00-0000 00:00(AM)		
	3	Clock Mode	12, 24 hours		12hours
	4	Language	English/Francais/Espanol/ Portuguese/Deutsch/ Italiano/Nederlands/Pycckn/Norsk/Polски/ Suomi/ Magyar/Dansk/Cestina/ Svenska/Turkse - 16 language		English
	5	Select Country	USA/Canada, India, Mexico, Colombia, Argentina, Venezuela, Chile, Peru, Brazil, Sri Lanka, Iraq, Russia, Ukraine		
	6	Power Save	On Off	5,15,30,60,120 min.	5
	7	Ignore Toner	On Off		
	8	USB Mode	Fast/Slow		Fast

Table 1:

1st level			2nd level	3rd level	Default Value
RETURN ◀--			RETURN		
left/right && Enter --▶		14 character	left/right && Enter		
3. Copy Setup ◀ Default-Change ▶	1	Default-Change	Lighten/Darken	Normal/Dark/Light	
			Original Type	Text, Text/Photo, Photo	
			Reduce/Enlarge	[Original(100%)]	
				[LGL - LTR(78%)]	
				[LGL - A4(83%)]	
				[A4 - A5](71%)	
				[A4 - LTR(94%)]	
				[EXE - LTR(104%)]	
				[A5 - A4](141%)	
				25%	
				50%	
			150%		
			200%		
			400%		
[Custom:25-400]					
	Copy Quantity	Copy Quantity P.[1-99]	1		
	Copy Collate	Off/On	Off		
2	Timeout	30, 60, 180, Off, 15 sec		30 sec	
3	Favorite feat.	Clone			
		Copy Collate			
		Auto Fit			
		ID Card Copy			
		2 Up			
		4 Up			
	Poster				
4. Copy Feature ◀ Off ▶	1	Off			
	2	Clone			
	3	Autofit			
	4	ID Card Copy			
	5	Poster			

Table 1:

1st level		2nd level	3rd level	Default Value
RETURN ◀--		RETURN		
left/right && Enter --▶	14 character	left/right && Enter		
5. Fax Setup ◀ Default-Change ▶	1	Default-Change	Resolution	Standard/Fine/Super Fine/Photo/Color
	2	Ring to Answer	1~7	2
	3	Lighten/Darken	Normal/Darken/Light	Normal
	4	Redial Term	1~15Min	3minutes
	5	Redials	1~13times	7times
	6	MSG Confirm	On, Off, On-Error	On-Error
	7	Image TCR	On, Off	
	8	Auto Report	On, Off	On
	9	Auto Reduction	On, Off	On
	10	Discard Size	0~30mm	20mm
	11	Receive Code	0~9	9
	12	DRPD Mode	set	
	13	Receive Mode	Fax, Tel, Ans/Fax, DRPD	
6. Fax Feature ◀ Delay Fax ▶	1	Delay Fax	Fax:	
	2	Priority Fax	Fax:	
	3	Add Page	Yes, No	
	4	Cancel Job	Yes, No	
7. Advanced fax	1	Send Forward	On,Off	Off
	2	RCV Forward	On	Start Time/ End Time Print Local Copy
			Off	Off
	3	Junk Fax Setup	On	Fax:
			Off	Off
	4	Secure Receive	On,Off, Print	Off
	5	Prefix Dial	FAX: xxxxx (5 digits)	
6	Stamp RCV Name	On,Off	Off	
7	ECM Mode	On,Off	On	
8. Reports ◀ Phone Book ▶	1	Phone Book		
	2	Sent Report		
	3	RCV Report		
	4	System Data		
	5	Scheduled Jobs		
	6	MSG Confirm		
	7	Junk Fax List		

Table 1:

1st level			2nd level	3rd level	Default Value	
RETURN ◀--			RETURN			
left/right && Enter --▶		14 character	left/right && Enter			
9. Sound/Volume ◀ Speaker ▶	1	Speaker	On, Off, Comm.		Comm.	
	2	Ringer	Off, Low,Med,High		Med	
	3	Key Sound	On, Off		Off	
	4	Alarm Sound	On, Off		On	
10. Maintenance ◀ Clean Drum ▶	1	Clean Drum	On,Off		Off	
	2	Notify Toner	On,Off		Off	
	3	Clear Memory	Clear All Mem.			
			Paper setting			
			Machine Setup			
			Copy Setup			
			Fax Setup			
			Fax Feature			
			Advanced Fax			
			Sound/Volume			
			Sent Report			
			RCV Report			
	Phone Book					
4	Remote Test	On,Off		Off		

GP 4 Tech Mode and Setting

How to Enter Tech Mode

In service (tech) mode the technician can check the machine and perform various tests to help with failure diagnosis.

When in Tech mode the machine still performs all normal operations.

To enter the Tech mode

To enter the Tech mode press

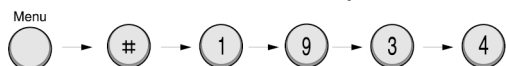

in sequence and the LCD briefly displays 'TECH', the machine has entered service (tech) mode.

Setting-up System in Tech Mode

Table 1:

1st level		2nd level	3rd level	Default Value		
RETURN ◀--		RETURN				
left/right && Enter --▶	14 character	left/right && Enter				
1 Tech Mode ◀ Data Setup ▶	1	Data Setup	Send Level	-9~-15	-12	
			DTMF Level			
			Pause Time			
			Dial Mode	Tone, Pulse	Tone	
			Modem Speed	33.6, 28.8, 14.4, 12.0, 9.6, 4.8 33.6	33.6	
			Error Rate	5%, 10%	10%	
			Notify Toner	Customer No.		
				Customer Name		
				Service No.		
				Serial No.		
				Clear All Mem.		
			Clear Count	Total Page Count	Enter Password	
				CRU Print CNT		
		FLT Scan Count				
		ADF Scan Count				
		Used Toner CNT				
		Edit Toner Dot				
		Flash Upgrade	Local			
			Remote			
			Silence Time	Off/ 12 Sec/Unlimited	Off	
		2	Machine Test	Switch Test	Reduce Panel	
					Complete Panel	
			Modem Test Dram Test Rom Test Pattern Test Shading Test			
	3	Report	Protocol			
			System Data			
			Key History			
			Error Info			
	4	New Cartridge	Yes/No			

Setting

Changing the Display Language

To change the language that displays on the control panel, follow these steps:

1. Press Menu until “Machine Setup” appears on the top line of the display.
2. Press the scroll key (◀ or ▶) until “Language” appears on the bottom line of the display.
3. Press Enter. The current setting appears on the bottom line of the display.
4. Press the scroll key (◀ or ▶) until the language you want appears on the display.
5. Press Enter to save the selection.
6. To return to Standby mode, press Stop/Clear.

Setting the Machine ID

In some countries, you are required by law to indicate your fax number on any fax you send. The Machine ID, containing your telephone number and name (or company name), will be printed at the top of each page sent from your machine.

1. Press Menu until “Machine Setup” appears on the top line of the display. The first available menu item, “Machine ID,” displays on the bottom line.
2. Press Enter. The display asks you to enter the fax number.
If there is a number already set, the number appears.
3. Enter your fax number using the number keypad.

Note: *If you make a mistake while entering numbers, press the ◀ key to delete the last digit.*

4. Press Enter when the number on the display is correct. The display asks you to enter an ID.
5. Enter your name or the company name using the number keypad.

You can enter alphanumeric characters using the number keypad, and include special symbols by pressing the 0 key.

For details on how to use the number keypad to enter alphanumeric characters.

If you want to enter the same letter or number in succession, enter one digit, move the cursor by pressing the ▶ key and enter the next digit.

If you want to insert a space in the name, you can also use the ▶ key to move the cursor to skip the position.

6. Press Enter when the name on the display is correct.
7. To return to Standby mode, press Stop/Clear.

Setting the Date and Time

When you turn your machine on for the first time, the display prompts you to enter the current date and time. After entering, it will not appear anymore. All faxes will have the date and time printed on them.

Note: *If power to the machine is cut off, you need to reset the correct time and date once the power has been restored.*

1. Press Menu until “Machine Setup” appears on the top line of the display.
2. Press the scroll key (◀ or ▶) to display “Date & Time” on the bottom line and press Enter.
3. Enter the correct time and date using the number keypad.

Note: *The date format may differ from country to country.*

You can also use the scroll key (◀ or ▶) to move the cursor under the digit you want to correct and enter a new number.

4. To select “AM” or “PM” for 12-hour format, press the # key or any number key. When the cursor is not under the AM or PM indicator, press the cursor to the indicator. Pressing will change the clock mode to 24-hour format (e.g. 01:00 PM as 13:00).
5. Press Enter when the time and date on the display is correct.
When you enter a wrong number, the machine beeps and does not proceed to the next step. If this happens, just reenter the correct number.
6. To return to Standby mode, press Stop/Clear.

Changing the Clock Mode

You can set your machine to display the current time using either a 12-hour or 24-hour format.

1. Press Menu until “Machine Setup” appears on the top line of the display.
2. Press the scroll key (◀ or ▶) until you see “Clock Mode” on the bottom line and press Enter. The clock mode currently set for the machine displays.
3. Press the scroll key (◀ or ▶) to select the other mode and then press Enter to save the selection.
4. To return to Standby mode, press Stop/Clear.

Setting the Paper Size and Type

After loading paper in the tray, you need to set the paper size and type using the control panel keys. These settings will apply to copy and fax modes. For PC-printing, you need to select the paper size and type in the application program you use on your PC.

1. Press Menu.
The display shows “Paper Setting” on the top line of the display.
2. Press the scroll key (◀ or ▶) to display “Paper Size” on the bottom line and press Enter to access the menu item.
3. Use the scroll key (◀ or ▶) to find the paper size you are using and press Enter to save it.
4. Press the key to scroll to “Paper Type” and press Enter to access the menu item.
5. Use the scroll key (◀ or ▶) to find the paper type you are using and press Enter to save it.
6. To return to Standby mode, press Stop/Clear.

Setting Sounds

You can control the following sounds:

- **Speaker:** You can turn on or off the sounds from the telephone line through the speaker, such as the dial tone or a fax tone. With this option set to “Comm.” the speaker is on until the remote machine answers.
- **Ringer:** You can adjust the ringer volume.
- **Key Sound:** With this option set to “On” a key tone sounds each time a key is pressed.
- **Alarm Sound:** You can turn the alarm sound on or off. With this option set to “On” an alarm tone sounds when an error occurs or fax communication ends.
- You can adjust the volume level using the manual dial.

Speaker, Ringer, Key Sound, and Alarm Sound

1. Press Menu until "Sound/Volume" appears on the top line of the display.
2. Press the scroll key (◀ or ▶) to scroll through the options. Press Enter when you see the desired sound option.
3. Press the scroll key (◀ or ▶) to display the desired status or volume for the option you have selected. You will see the selection on the bottom line of the display. For the ringer volume, you can select "Off," "Low," "Med," and "High". Setting "Off" means that the ringer does not sound. The machine works normally even if the ringer is turned off.
4. Press Enter to save the selection. The next sound option appears.
5. If necessary, repeat steps 2 through 4.
6. To return to Standby mode, press Stop/Clear.

Speaker Volume

1. Press the Manual dial. A dial tone sounds from the speaker.
2. Press the scroll key (◀ or ▶) until you hear the volume you want. The display shows the current volume level.
3. Press the Manual dial to save the change and return to Standby mode.

Note: You can adjust the speaker volume only when the telephone line is connected.

Toner Save Mode

Toner Save mode allows your machine to use less toner on each page. Activating this mode extends the life of the print cartridge, but it reduces print quality. Toner Save is selected in the Printer Properties window.

Power Save Mode

Power Save mode allows your machine to reduce power consumption when it is not in actual use. You can turn this mode on and select a length of time for which the machine waits after a job is printed before it switches to a reduced power state.

1. Press Menu until "Machine Setup" appears on top line of the display.
2. Press the scroll key (◀ or ▶) until "Power Save" appears on the bottom line. Press Enter.
3. Press the scroll key (◀ or ▶) to display "On" on the bottom line and press Enter.
Selecting "Off" means that the power save mode is deactivated.
4. Press the scroll key (◀ or ▶) until the time setting you want appears.
The available options are 5, 10, 15, 30, and 45 (minutes).
5. Press Enter to save the selection.
6. To return to Standby mode, press Stop/Clear.

FLASH UPGRADE

There are 2 methods to update the Flash Rom, Local and Remote.

(1) Local Machine

- RCP (Remote Control Panel) mode

This method is for Parallel Port or USB Port. Connect the PC and activate the RCP (Remote Control Panel) to upgrade the Firmware.

< Method >

How to Update Firmware using RCP

1. Connect PC and Printer with a Parallel Cable or a USB Cable.
2. Run the RCP utility and select Firmware Update.
3. Search for the Firmware file to be used to update the set using the Browse Icon.
4. Click the Update icon. The firmware file is transmitted to the Printer automatically and the printer is initialized when the download completes.
5. Click the Refresh icon and check that the updated version numbers are displayed.

• DOS Command mode

This method is ONLY for Parallel Port. Connect the PC to the set using a Parallel Cable and enter the DOS Command to upgrade the firmware.

< Method >

1. First of all you need the following files: down.bat, down_com.bin, fprt.exe, and Rom File: (file name for upgrade). Ensure you save ALL of these files in the same folder.
 2. At the DOS prompt enter the correct command (as shown below) and push the enter key. Then the upgrade will automatically take place.
 3. There are two commands use the correct one depending on the condition of the set.
 - * When the product is in the idle condition **down "rom file"**
 - * When the product is in Ready condition
(TECH MODE --> DATA SETUP --> FLASH UPGRADE --> LOCAL)
- copy/b "rom file" lpt1**
4. Do not turn off the power during the upgrade process.

(2) Remote FAX

It is possible to use a set that already has the latest firmware to upgrade a remote set remotely using the telephone system.

< Method >

1. On the set that has the latest firmware set it to transmit the upgrade:-
(TECH MODE •DATA SETUP•••• FLASH UPGRADE•••• REMOTE)
2. Enter the telephone number of the set that needs to be upgraded.
(Several faxes can be upgrade at the same time. In this case, enter each fax number.)
3. When the enter key is pressed the set sends the firmware file by calling designated fax number. (Around 10~15 minutes are needed to send the file.)

< Caution >

1. The Sending and Receiving fax machines MUST be the same model.
2. The sending fax must be set up in ECM mode and the Receiving fax memory must be 100%. If not the function will not work.

Machine Test

SWITCH TEST

Use this feature to test all keys on the operation control panel. The result is displayed on the LCD window each time you press a key.

MODEM TEST

Use this feature to hear various transmission signals to the telephone line from the modem and to check the modem, amplifier and speaker. If no transmission signal sound is heard, it means the modem part of the main board, amplifier, speaker or speaker harness is faulty.

DRAM TEST

Use this feature to test the machine's DRAM. The result appears in the LCD display. If all memory is working normally, the LCD shows << O K >>

ROM TEST

Use this feature to test the machine's ROM. The result and the software version appear in the LCD display.

- FLASH VER: 1.00 V
- ENGINE VER:1.00V

PATTERN TEST

Using this pattern printout you can check that the printer mechanism is functioning properly. This function is for factory manufacturing use only.

SHADING TEST

The function is used to set the optimum scan quality determined by the specific characteristics of the CIS (Contact Image Sensor). If copy image quality is poor perform this function to check the condition of the CIS unit.

Note: Before performing the shading test, place a sheet of blank white paper on the platen glass.

< Method >

1. Select the [Shading Test] in TECH MODE (Menu, #, 1934).
2. Push the ENTER key and an image will be scanned.
3. After scanning the CIS SHADING PROFILE will be print out.
4. If the printed image is different to the sample image shown the CIS is defective.

Note: When you test the CIS, make sure that the cover is closed.

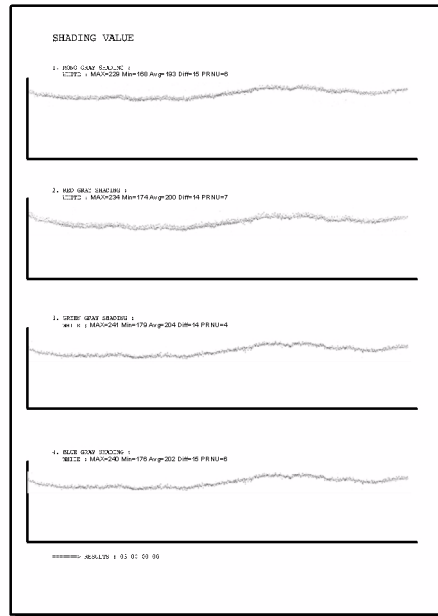

Figure 1

Report

PROTOCOL LIST

This list shows the sequence of the CCITT group 3 T.30 protocol during the most recent sending or receiving operation. Use this list to check for send and receive errors. If

SYSTEM DATA

This list provides a list of the user system data settings and tech mode settings.

KEY HISTORY

This list shows the input key history.

ERROR INFO



This list display the detail machine error list.

GP 5 Control Panel

Control Panel Functions



Figure 1

Lighten/Darken	Adjusts the brightness of the documents for the current copy job.
Original Type	Selects the document type for the current copy job.
Reduce/Enlarge	Makes a copy smaller or larger than the original.
Favourite Copy	Allows you to use one of the special copy features, such as Clone, Collation, Auto fit, 2 Sides on 1 page, 2/4 Up (multiple pages on a sheet), and Poster copying after assigning it.
	Displays the current status and prompts during an operation.
	Used to scroll through the available options for the selected menu item.
Enter	Confirms the selection on the display.
Menu	Enters Menu mode and scrolls through the menus available.
Exit	Sends you back to the upper menu level.
Start	Starts a job.
Stop/Clear	Stops an operation at any time. In Standby mode, clears/cancels the copy options, such as the darkness, the document type setting, the copy size and the number of copies.
Number Keypad	Dials a number or enters alphanumeric characters.
Resolution	Adjusts the resolution of the documents for the current fax job.
Broadcasting	Allows you to send a fax to multiple destinations.
Phone Book	Allows you to store frequently dialed fax numbers as one or two-digit speed dial or group dial numbers for automatic dialling and edit the stored numbers. Also allows you to print a Phonebook list.
Redial/Pause	In Standby mode, redials the last number or in Edit mode, inserts a pause into a fax number.
Manual Dial	Engages the telephone line.
Scan	Selects the scan feature software (Printer Settings Utility) provided.
Toner Save	Allows you to save on toner by using less toner to print a document.
Copy	Selects the copy feature.
Fax	Selects the Fax feature.

GP 6 LCD Status Error Messages

Table 1:

STATUS	LCD Display	Descriptions
Document Jam	Document Jam	When Document Jam occurred at ADF module.
Door Open or Jam Cover Open	[Front or Rear] [Cover Open]	When machine' front side cover or Jam Cover was opened.
NO paper	[No Paper] Add Paper	When there is no paper in CASSETTE Tray.
PAPER JAM 0	[Paper Jam 0] Open/Close Door	When the machine encountered paper jam in pick up area, Machine displays on the LCD until DOOR OPEN & CLOSE.
PAPER JAM 1	[Paper Jam 1] Open/Close Door	When the machine encountered paper jam in paper exit of Machine, machine displays on the LCD until DOOR OPEN & CLOSE.
PAPER JAM 2	[Paper Jam 2] Check Inside	When the machine encountered paper jam in paper exit of Machine, machine displays on the LCD until DOOR OPEN & CLOSE.
Communication Error	[COMM. Error]	When the machine has a problem in communication. Machine displays this in case of Transmission. Machine displays this in case of fax handshaking step of Reception.
Line Error	[Line Error]	When the machine has problem in case of Fax Data reception step.
NO ANSWER	[No Answer]	When the machine could not connect to remote fax after Completion of redial up to redial counter in system data.
INCOMPATIBLE	[Incompatible]	Remote party did not have the requested feature, such as polling.
LINE BUSY	Line Busy	The remote fax did not answer.
POWER FAILURE	Power Failure	When the machine user memory has not been backed up and there was power off / on.
STOP PRESSED	[Stop Pressed]	When the operator pressed the STOP key during transmission.
MEMORY FULL	Memory Full	When the machine has encountered the user memory was full,
FUSER ERROR	CRU Fuse Error	When the machine failed in installing the new print cartridge.
LSU ERROR	[Hsync Error]	Tech mode
LSU ERROR	[LSU Error]	User mode The LSU does not reach the READY state,
TONER LOW	[Toner Low]	The machine has encountered the Toner Low,
TONER EMPTY	[Toner Empty]	The machine has encountered the Toner Empty,
BYPASS JAM	[Bypass Jam]	The machine detected the non feeding from BYPASS Tray.
GROUP is not available	Group Not Available	You have tried to select a group location where only a single Location number can be used.
RETRY REDIAL?	Retry Redial?	The machine is waiting for the programmed interval to automatically redial a previously busy station.
NO. NOT ASSIGNED	NO. Not Assigned	The speed dial location you tried to use has no number assigned to it.

Table 1:

STATUS	LCD Display	Descriptions
Load document	Load Document	You have attempted to set up a sending operation with no Document loaded.
Memory full and cancel the job	Cancel? 1:Yes 2:No	When the machine has encountered the memory full during storing the document into memory, the machine display the "CANCEL ?" to operator whether he/she make a decision the cancelling the job or accept the scanned page so far to transmit the remained documents.
Job has not been created	Operation Not Assigned	When operator is doing in ADD/CANCEL operation and There is no job to handle if operator entered the job no.
Low Heat Error	[Low Heat Error]	Temperature could not reach certain level.
Open Fuser Error	Open Fuser Error	The thermistor has been disconnected.
Over Heat Error	[Over Heat]	Temperature has gone up very high degree.
	[Jam 1] [No Cartridge]	When the machine detected the print cartridge has not been installed, or detected jam1 in warm-up state.
Memory Dial Full	Memory Dial Full	During Auto dial transmission when all 15 jobs are configured and try to add 16th job

GP 7 Engine Test Mode

The Engine Test Mode supplies useful functions to check the condition of the print engine. It tests the condition of each device and displays the result of the test on the LCD. It is divided into 5 functions (0~4), and these are shown below.

To enter the Engine Test Mode

Press

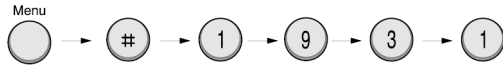

in sequence and the LCD briefly displays

'**Engine Test**', the machine has entered Engine Test mode.

Press "0", "1", "2", "3" or "4" to select the Test No. (see [Table 1](#) – left hand column)

Table 1:

NO.	Sub No.	Engine test	Remark
0	1	Motor Test	1 : On, 2 : Off – next test selected
	2	Pick Up Test	1 : On, 2 : Off – next test selected
	3	Fan Test	1 : On, 2 : Off – next test selected
	4	Manual Clt Test	1 : On, 2 : Off – next test selected
	5	PTL Test	1 : On, 2 : Off – next test selected
1	1	LSU Motor Test	1 : On, 2 : Off – next test selected
	2	LSU Hsync Test	1 : On, 2 : Off – next test selected
	3	LD Test	1 : On, 2 : Off – next test selected
2	1	Feed Sensor Test	1. Check : read the sensor
			2. Next : Next Sensor test
	2	Exit Sensor Test	1. Check : read the sensor
			2. Next : Next Sensor test
	3	Cover Sensor Test	1. Check : read the sensor
2. Next : Next Sensor test			
4	Empty Sensor Test	1. Check : read the sensor	
		2. Next : Next Sensor test	
5	Manual Sensor Test	1. Check : read the sensor	
		2. Next : Next Sensor test	
3	1	Therm ADC 180	1 : On, 2 : Off (maintain the fusing temp. 80°C)
	2	Therm ADC 140	1 : On, 2 : Off (maintain the fusing temp. 135°C)
	3	Therm ADC 120	1 : On, 2 : Off (maintain the fusing temp. 160°C)
	4	Therm ADC 100	1 : On, 2 : Off (maintain the fusing temp. 191°C)
4	1	MHV Test	1 : On, 2 : Off (-1550V ± 50V)
	2	Dev Bias Test	1 : On, 2 : Off (-430V ± 20V)
	3	THV EN/NEG Test	1 : On, 2 : Off (-1200V +300V/-150V)
	4	THV ON (1300V)	1 : On, 2 : Off (+1300V ± 20V)
	5	THV ADC 1300V	1 : On, 2 : Off (ADC Value : 101 ± 5)
	6	THV ADC 600V~3500V	1 : On, 2 : Off (Compare each ADC Value)

Detail Description (Engine Test Mode)

Table 1:

01.Motor Test	The main motor starts when the execution key is pressed and stops when the stop key is pressed.	Main Motor On/Off
02.Pick Up Test	Automatically stops, when the execution is chosen. stops, when the execution is chosen.	Tray 1,2 Solenoid On/Off
03.Fan Test	The fan starts when the execution key is pressed and stops when the stop key is pressed.	Fan On/Off
04.Manual Clutch Test	The tray2,3 clutch is on for 1sec and then it automatically stops, when the execution is chosen.On this function, the main motor runs before 2sec from the point of the clutch on in order to check the clutch state.	Tray 2,3 Clutch On/Off
05.PTL Test	PTL (Pre-Transfer Lamp) is lights when the execution key chosen and it stops when the stop key is chosen.	PTL On/Off
11.LSU Motor	The laser motor starts when the execution key is pressed and stops when the stop key is pressed.	Laser Motor On/Off
12.LSU Hsync Test	The LSU motor starts and "Laser Ready" is displayed if the motor spins at the correct speed, otherwise "Laser Error" is displayed.	Laser Ready On/Off
13.LD Test	"Diode On" is displayed, when the laser diode is on. Otherwise "Diode Off" is displayed.	Diode On/Off
21.Feed Sen Test	These functions allow the current state of the sensor to be displayed.	"Sensor Off" or "Sensor On"
22.Exit Sen Test		
23.Cover Sen Test	This function allows the current state of the Cover sensor to be displayed. Touch the sensor and confirm that the message changes: "Cover Open" to "Cover Close"	"Cover Open" or "Cover Close"
24.Empty Sen Test	These functions allow the current state of the sensor to be displayed.	"Sensor Off" or "Sensor On"
25.Manual Sen Test		
31.Them ADC 180	"Current value" is displayed on the upper line of the LCD, and "Target value" on the bottom line. Target value is limited from "191°C" to "80°C"	Target temperature and output temperature from thermistor and ADC.
32.Them ADC 140		
33.Them ADC 120		
34.Them ADC 100		
41.MHV Test	These Functions are provided to check whether the control of the HVPS is functioning correctly.	MHV On/Off
42.Dev Bias Test		Dev Bias On/Off
43.THV EN/NEG Test		THV EN/NEG On/Off
44.THV ON(1300V)		THV On/Off
45.THV ADC 1300V		ADC value displayed.
46.THV ADC 600V~3500		ADC value displayed.

GP 8 Paper Path and Clearing Paper Jams

Scan Document Path

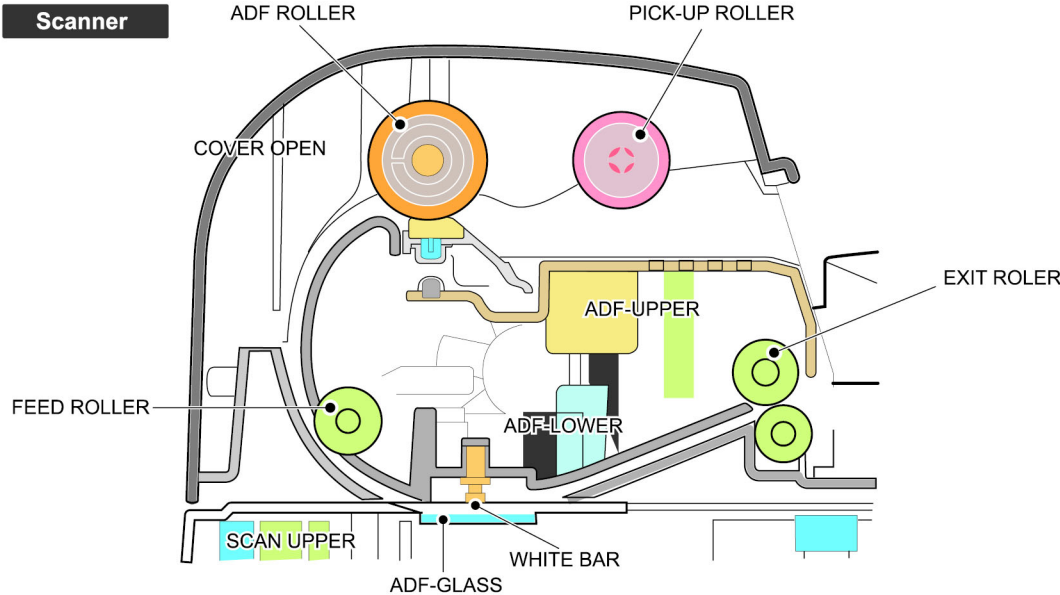

Figure 1

Printer Paper Path

- 1) After receiving a print command, the printer feeds paper from the main cassette or manual feeder as required.
- 2) The paper being fed passes the paper feed sensor. (Jam 0 occurs if the sensor is not operated within a certain time)
- 3) Having passed the paper feed sensor the paper moves to the paper exit sensor via printing process. (Jam 1 occurs if the sensor is not operated within a certain time)
- 4) The paper then passes through the paper exit sensor and out of the set. (Jam 2 occurs if the trailing edge of the paper does not pass the exit sensor within a certain time of the paper leading edge activating the exit sensor)

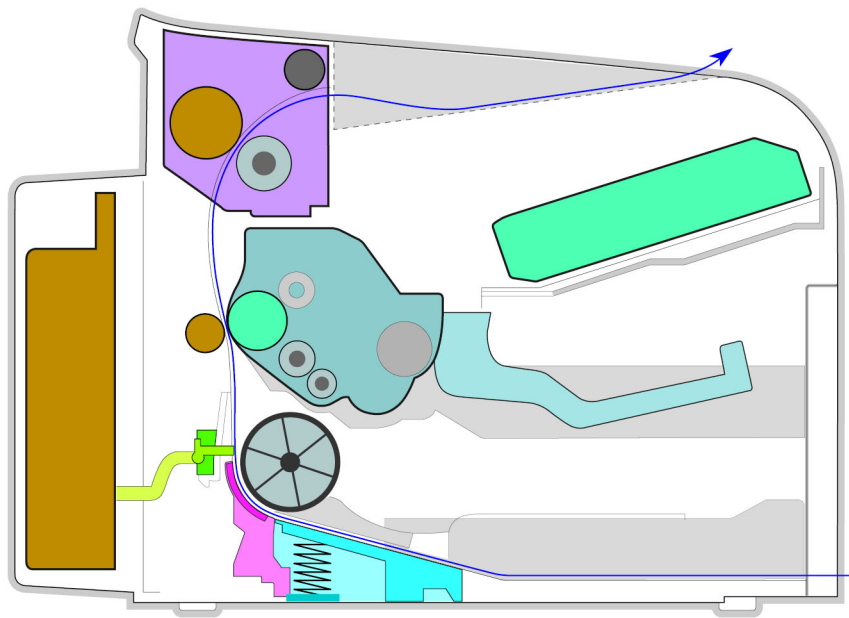

Figure 2

Clearing Paper Jams

When a paper jam occurs, “Paper Jam” appears on the display. Refer to the table below to locate and clear the paper jam.

Table 1:

Message	Location of Jam
[Paper Jam 0] Open/Close Door	In the tray
[Paper Jam 1] Open/Close Door	In the fuser area or around the print cartridge.
[Paper Jam 2] Check Inside	In the paper exit area

To avoid tearing the paper, pull out the jammed paper gently and slowly. Follow the instructions in the following sections to clear the jam.

In the Tray

1. Remove the jammed paper in the tray by gently pulling it straight out.

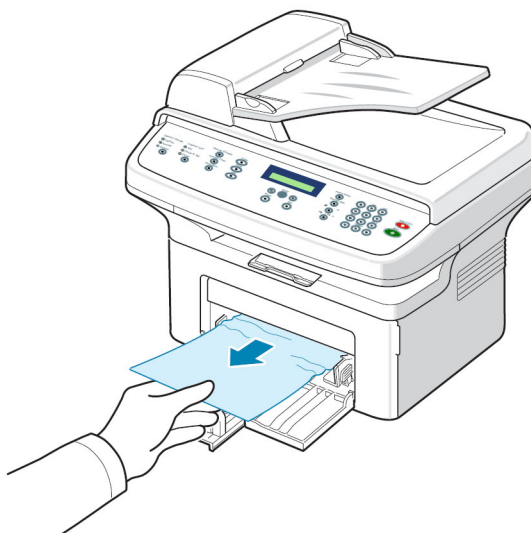

Figure 1

2. Open and close the front door to resume printing.

In the Fuser Area or Around the Print Cartridge

Note: *The fuser area is hot. Take care when removing paper from the machine.*

1. Open the front door and pull the print cartridge out, lightly pushing it down.

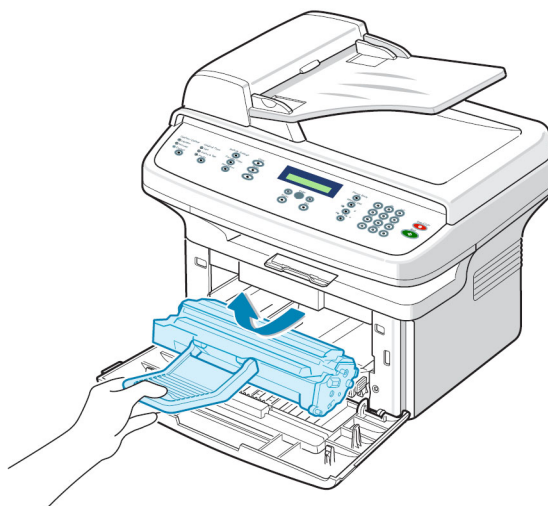

Figure 1

2. Remove the jammed paper by gently pulling it straight out.



Figure 1

3. Replace the print cartridge and close the front door. Printing automatically resumes.

In the Paper Exit Area

1. Open and close the front door. The jammed paper automatically exits the machine. If the paper does not exit, continue to step 2.
2. Gently pull the paper out of the output tray.



Figure 1

3. If there is any resistance and the paper does not move when you pull, or if you cannot see the paper in the output tray, open the rear door by pulling the tab on it.

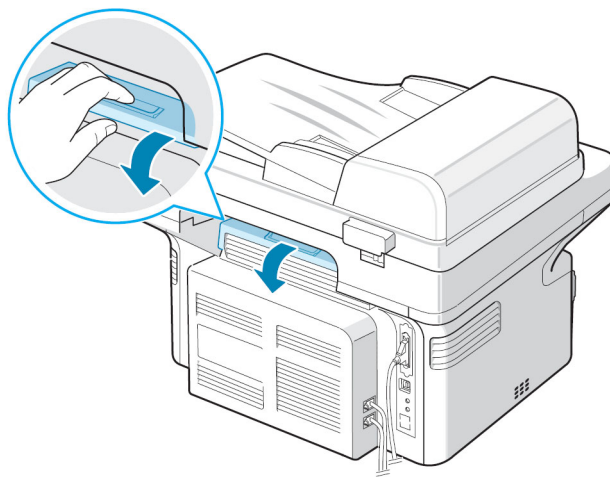

Figure 2

4. Remove the jammed paper by gently pulling it straight out.

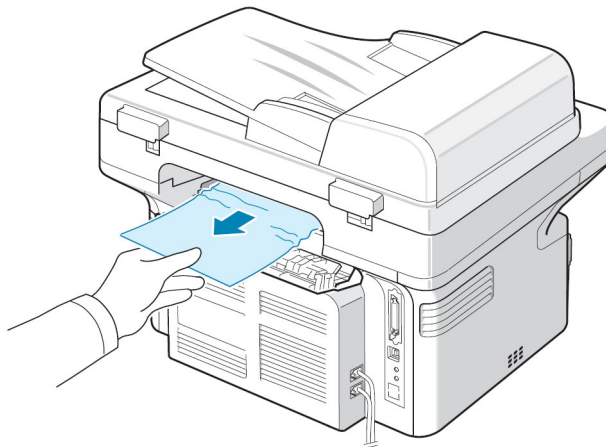

Figure 3

Note: Inside of the machine is hot. Take care when removing paper from the machine

5. Close the rear door.

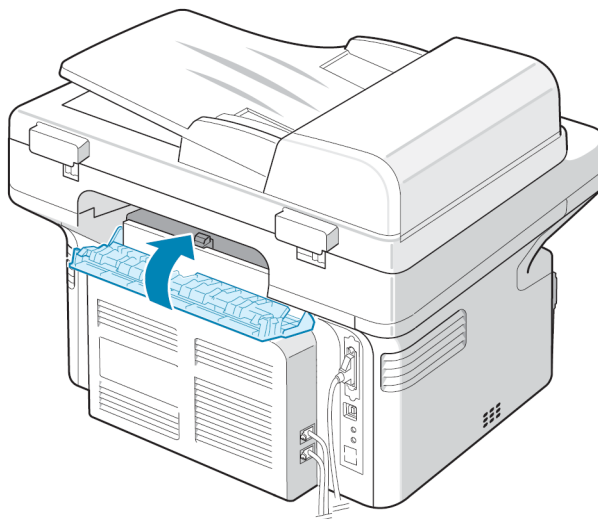

Figure 4

6. Open and close the front door to resume printing.

Tips for Avoiding Paper Jams When Printing on the A5-sized Paper

If paper jams occur frequently when you print on A5-sized paper:

1. Load the paper into the tray, as shown below.

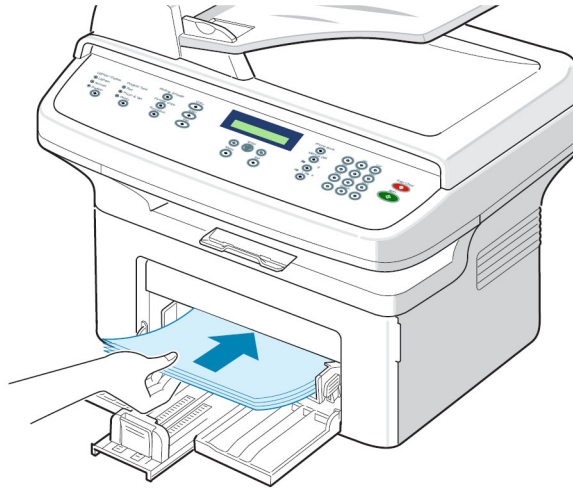

Figure 1

2. Open the printer's properties window, set the paper size to A5 from the Paper tab.
3. From the Orientation option of the Layout tab, set the Rotate option to 90.
4. Click OK to start printing. For details, see Software User's Guide.

Tips for Avoiding Paper Jams

By selecting the correct paper types, most paper jams can be avoided. When a paper jam occurs.

- Follow the procedures in "Loading Paper". Ensure that the adjustable guides are positioned correctly.
- Do not overload the tray.
- Do not remove paper from the tray while your machine is printing.
- Flex, fan, and straighten the paper before loading.
- Do not use creased, damp, or highly curled paper.
- Do not mix paper types in the tray.
- Use only recommended print materials. See "Paper Specifications".
- Ensure that the recommended print side of print materials is facing up in the tray.

GP 9 General Precautions on Disassembly

When you disassemble and reassemble components, you must use extreme caution. The close proximity of cables

to moving parts makes proper routing a must.

If components are removed, any cables disturbed by the procedure must be restored as close as possible to their original positions. Before removing any component from the machine, note the cable routing that will be affected.

Whenever servicing the machine, you must perform as follows:

1. Check to verify that documents are not stored in memory.
2. Be sure to remove the print cartridge before you disassemble parts.
3. Unplug the power cord.
4. Use a flat and clean surface.
5. Replace only with authorized components.
6. Do not force plastic-material components.
7. Make sure all components are in their proper position.
8. Run a settings report if possible to restore customer settings at the end of the service call.

Releasing Plastic Latches

Many of the parts are held in place with plastic latches. The latches break easily; release them carefully.

To remove such parts, press the hook end of the latch away from the part to which it is latched.



Figure 1

GP 10 Tools

The following tools are recommended.

DVM (Digital Volt Meter)

Standard: Indicates more than 3 digits.

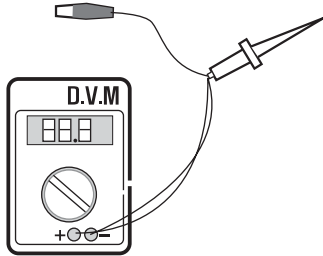

Driver

Standard: "-" type, "+" type (M3 long, M3 short, M2 long, M2 short).

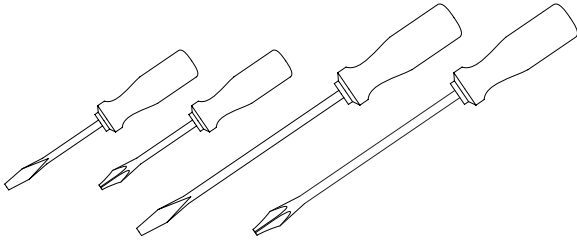

Tweezers

Standard: For general home use, small type.

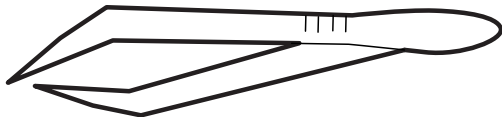

Cotton Swab

Standard: For general home use, for medical service.



Cleaning Equipment

Standard: An IPA (Isopropyl Alcohol) dry wipe tissue or a gentle neutral detergent and lint-free cloth.

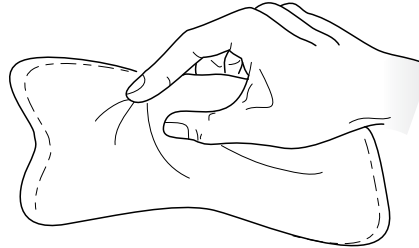

Vacuum Cleaner

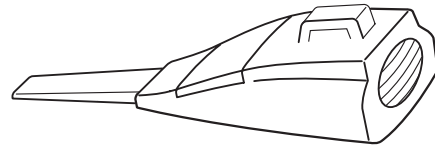

Spring Hook

Standard: For general use



Software (Driver) installation CD ROM

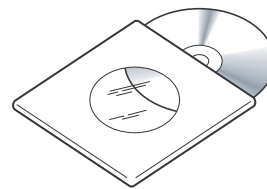

GP 11 Acronyms and Abbreviations

The table below explains the abbreviations and acronyms used in this service manual. Where abbreviations or acronyms are used in the text please refer to this table.

Table 1: Acronyms and Abbreviations

Abbreviations	Explanation
AP	Access Point
AC	Alternating Current
APC	Auto Power Control
ASIC	Application Specific Integrated Circuit
BIOS	Basic Input Output System
BLDC	Brush-less Direct Current
CN	connector
CON	connector
CPU	Central Processing Unit
dB	decibel
dbA	decibel A
dBm	decibel milliwatt
DC	direct current
DCU	Diagnostic Control Unit
DPI	Dot Per Inch
DRAM	Dynamic Random Access Memory
DVM	Digital Voltmeter
ECP	Enhanced Capability Port
EDC	Embedded Diagnostic control
EEPROM	Electrically Erasable Programmable Read Only Memory
EMI	Electro Magnetic Interference
EP	electrophotographic
EPP	Enhanced Parallel Port
FPOT	First Printout Time
F/W	firmware
GDI	graphics device interface
GND	ground
HBP	Host Based Printing
HDD	Hard Disk Drive
H/H	High temperature and high humidity
HV	high voltage
HVPS	High Voltage Power Supply
I/F	interface
I/O	Input and Output
IC	integrated circuit
IDE	Intelligent Drive electronics or Embedded Drive Electronics
IEEE	Institute of Electrical and Electronics Engineers. Inc.
IPA	Isopropyl Alcohol
IPM	Images Per Minute

Table 1: Acronyms and Abbreviations

Abbreviations	Explanation
LAN	local area network
lb	pound(s)
LBP	Laser Beam Printer
LCD	Liquid Crystal Display
LED	Light Emitting Diode
LIU	Line Interface Unit
L/L	Low temperature and low humidity
LSU	Laser Scanning Unit
MB	megabyte
MHz	megahertz
MPF	Multi Purpose Feeder
NIC	Network Interface Card
N/N	Normal temperature and normal humidity
NVRAM	nonvolatile random access memory
OPC	Organic Photo Conductor
OPE	Operate Panel Equipment
PBA	Printed Board Assembly
PCL	Printer Command Language, Printer Control Language
PDL	Page Discription Language
PPM	Page Per Minute
PPS	Pulse Per Second
PS	Post Script
PTL	Pre-Transfer Lamp
PWM	Pulse Width Modulation
Q-PID	Quick Printer Initiating Device
Qt'y	quantity
RAM	Random Access Memory
ROM	Read Only Memory
SCF	Second Cassette Feeder
SMPS	Switching Mode Power Supply
Spool	Simultaneous Peripheral Operation Online
SW	switch
sync	synchronous or synchronization
USB	Universal Serial Bus
WECA	Wireless Ethernet Compatibility Alliance

GP 12 Selecting printer locations

Leave enough room to open the printer trays, covers, and allow for proper ventilation. (see diagram below)

Provide the proper environment:

- A firm, level surface
- Away from the direct airflow of air conditioners, heaters, or ventilators
- Free of extreme fluctuations of temperature, sunlight, or humidity
- Clean, dry, and free of dust

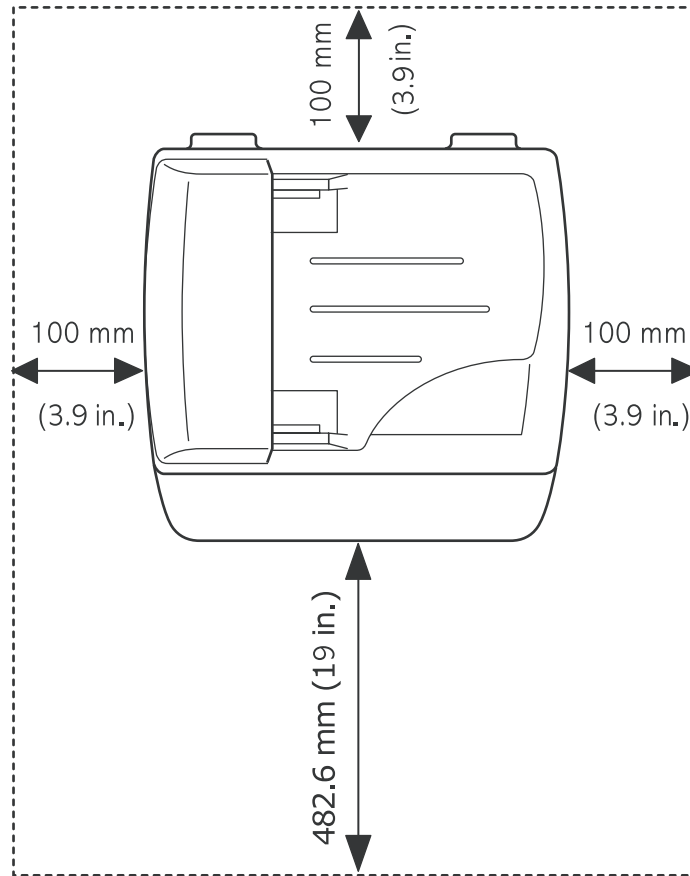

Figure 1

GP 13 Sample Test Pattern

The sample pattern shown below is the standard test pattern used in the factory. The life of the print cartridge, developer cartridge and printing speed are measured with the pattern shown below of 5% area coverage. The pattern is shown at approximately 70% of actual size.

A4 ISO 19752 Standard Pattern

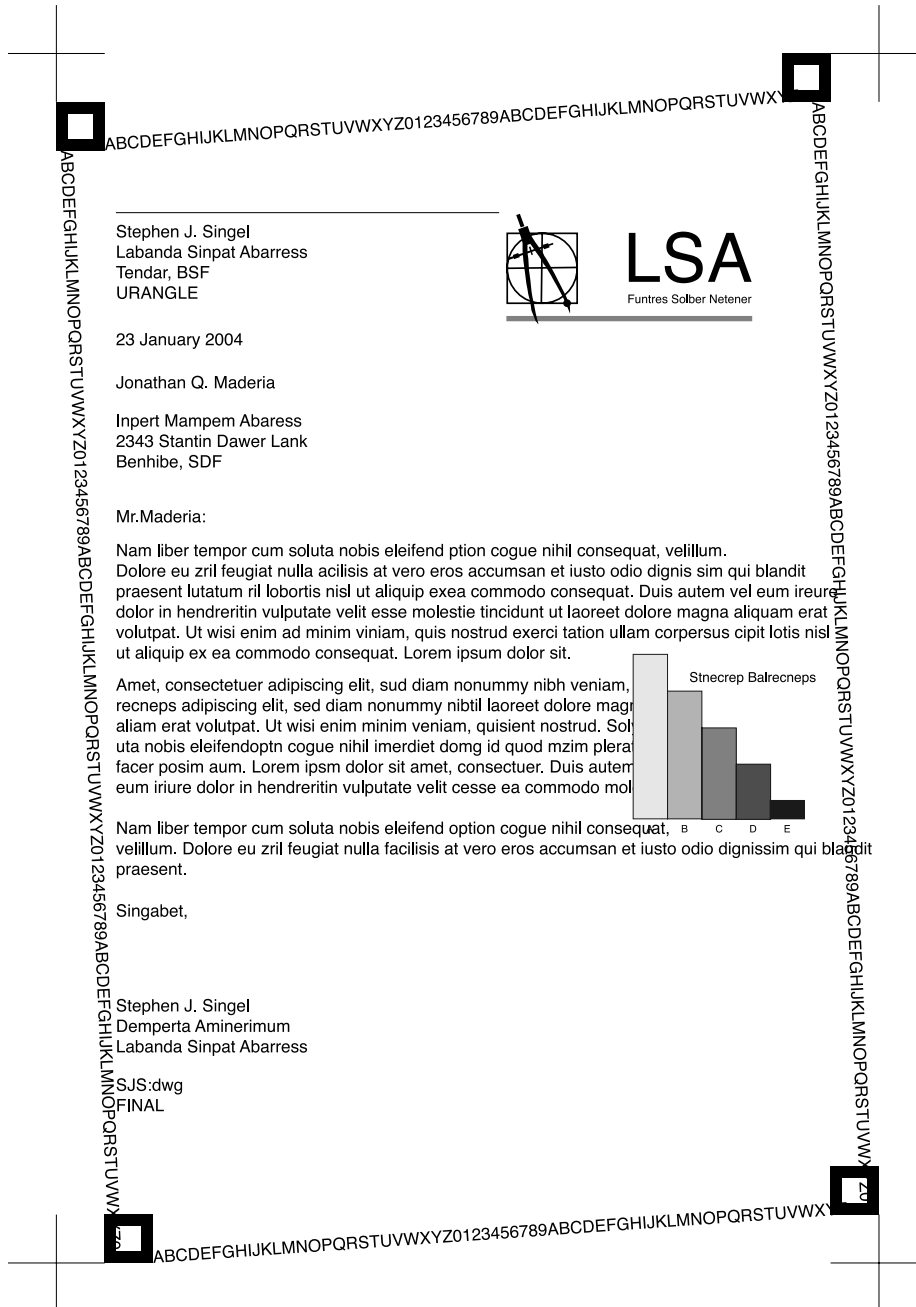

Figure 1

GP 14 Service Log

Service Log

Use the service log to record all service procedures. [Figure 1](#).

Service log

XEROX		ADF		OPTICS		FUSER		XERO		PAPER FEED		MISC	
Serial Number	Account Data	Key Op										Adjustment	Installed Tag
Date	Meter	CSE											
1	Problem	Subsystem	Inc										
PLEASE PRINT													
2	Problem	Subsystem	Inc										
3	Problem	Subsystem	Inc										
4	Problem	Subsystem	Inc										
5	Problem	Subsystem	Inc										

Page intentionally blank

7. Wiring Data

WD 1 System Block Diagram	7-3
WD 2 PJ Locations	7-4
WD 3 Connection Diagram (1/2)	7-5
WD 4 Connection Diagram (2/2)	7-6
WD 5 Main Board (1/7)	7-7
WD 6 Main Board (2/7)	7-8
WD 7 Main Board (3/7)	7-9
WD 8 Main Board (4/7)	7-10
WD 9 Main Board (5/7)	7-11
WD 10 Main Board (6/7)	7-12
WD 11 Main Board (7/7)	7-13
WD 12 LIU	7-14
WD 13 OPE	7-15
WD 14 LSU	7-16
WD 15 ADF	7-17
WD 16 SMPS	7-18
WD 17 HVPS (1/3)	7-19
WD 18 HVPS (2/3)	7-20
WD 19 HVPS (3/3)	7-21

Page intentionally blank

WD 1 System Block Diagram

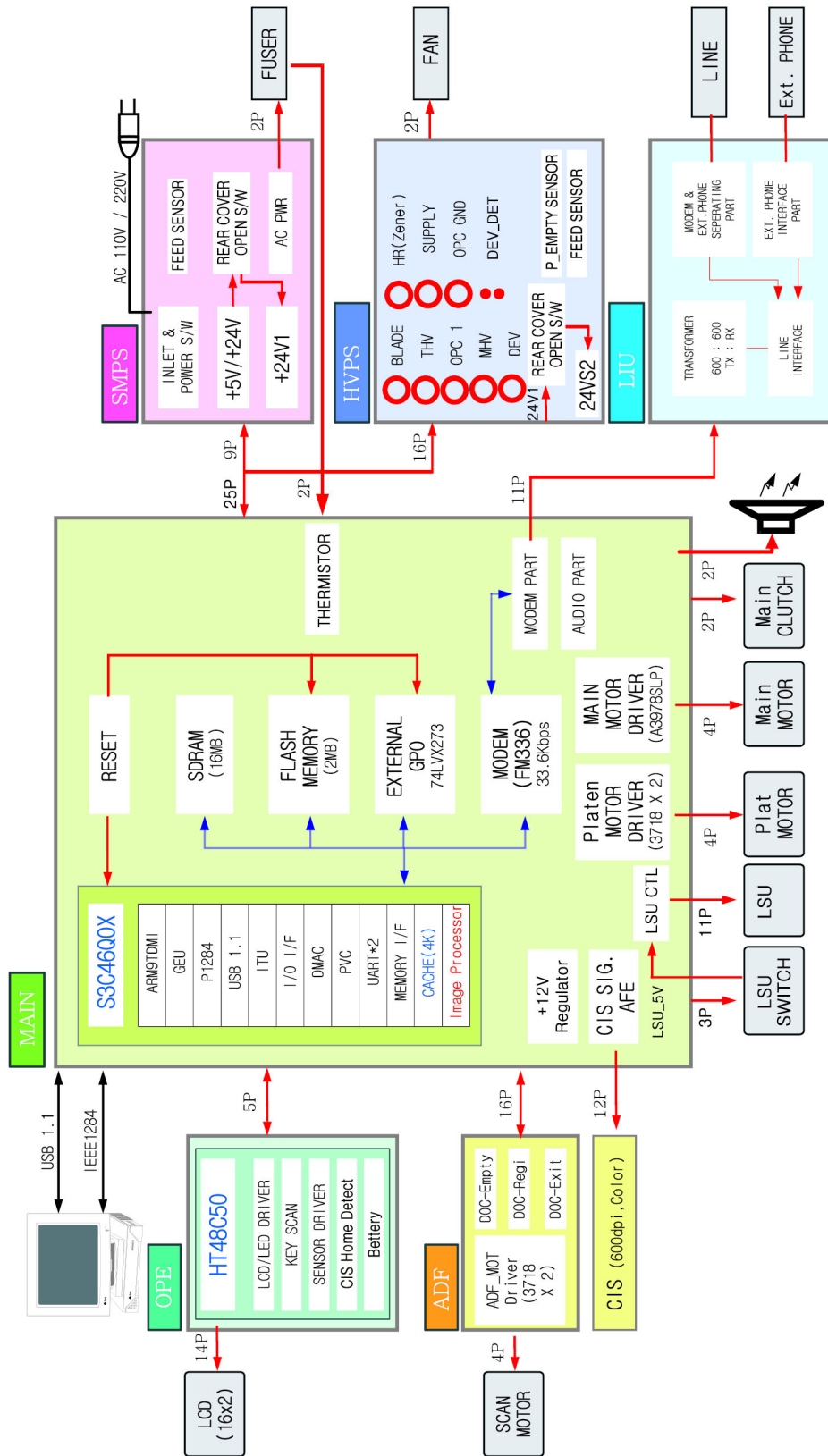

WD 2 PJ Locations

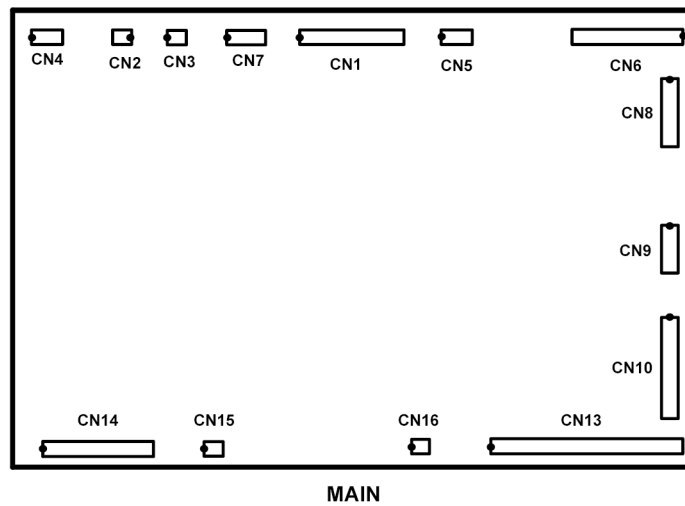
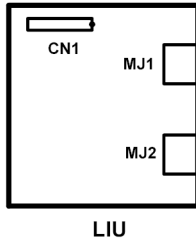
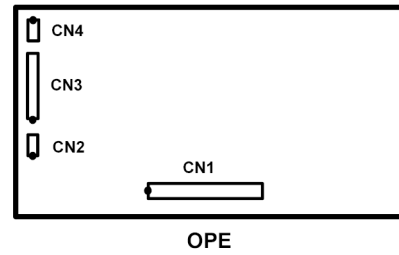
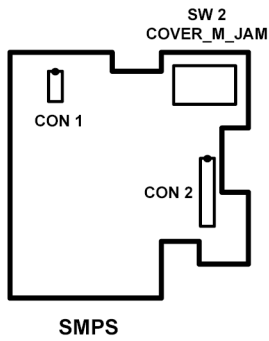
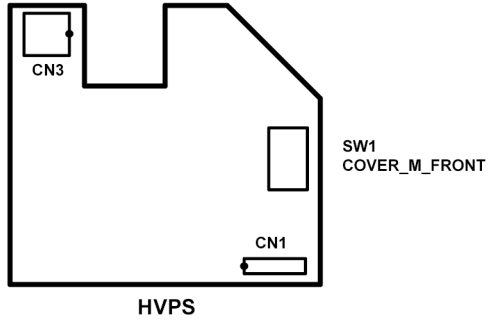

WD 3 Connection Diagram (1/2)

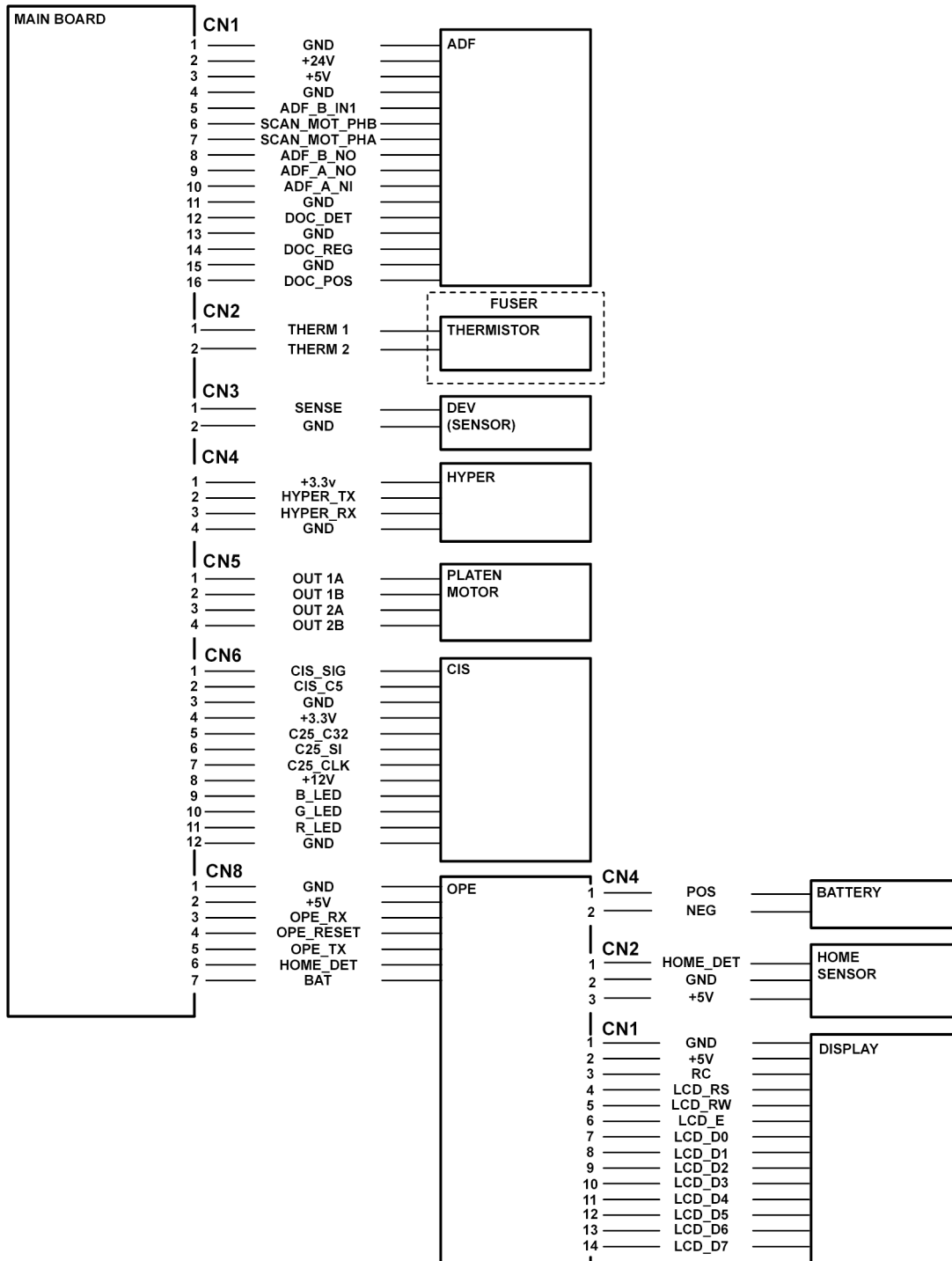

WD 4 Connection Diagram (2/2)

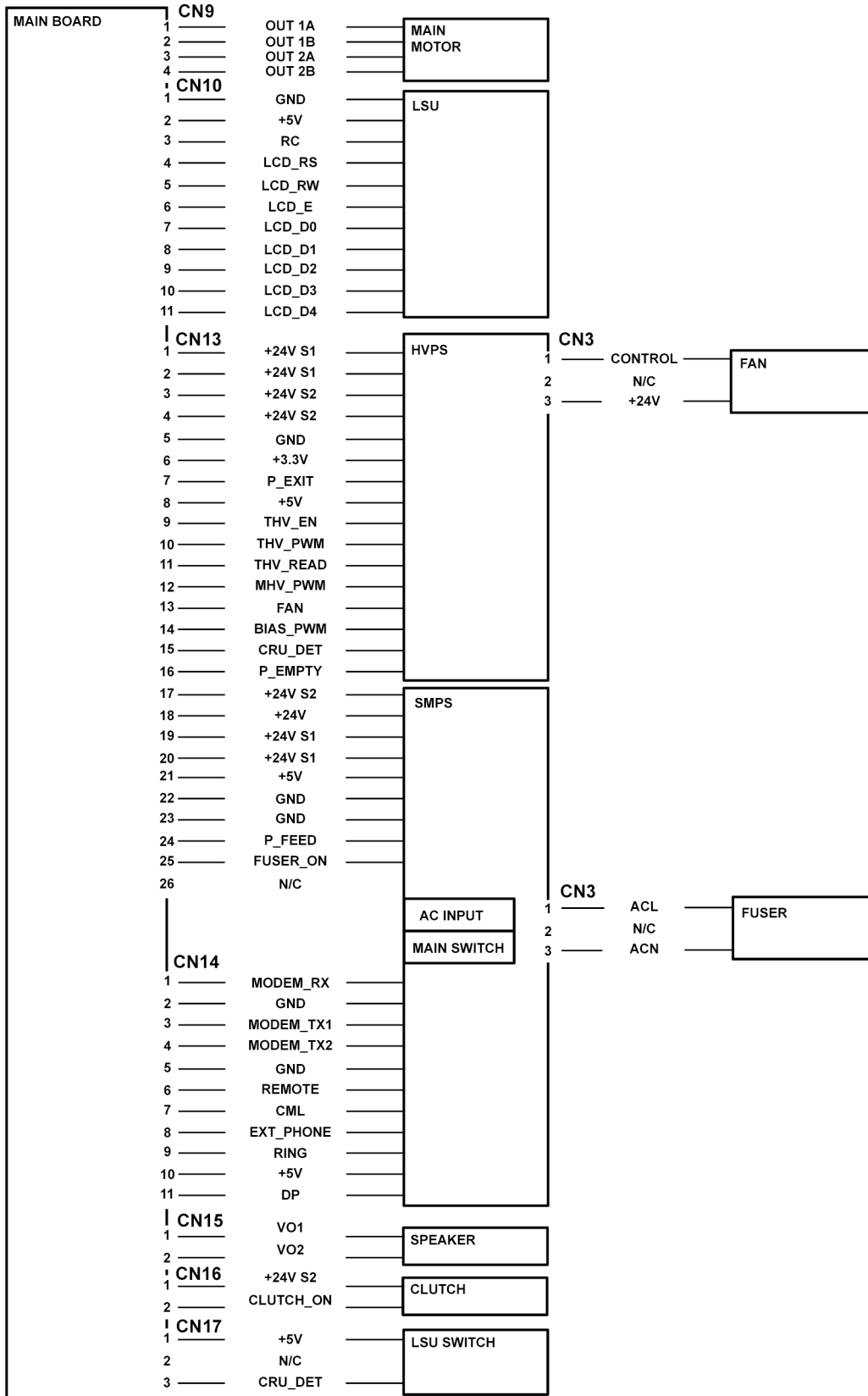

WD 7 Main Board (3/7)

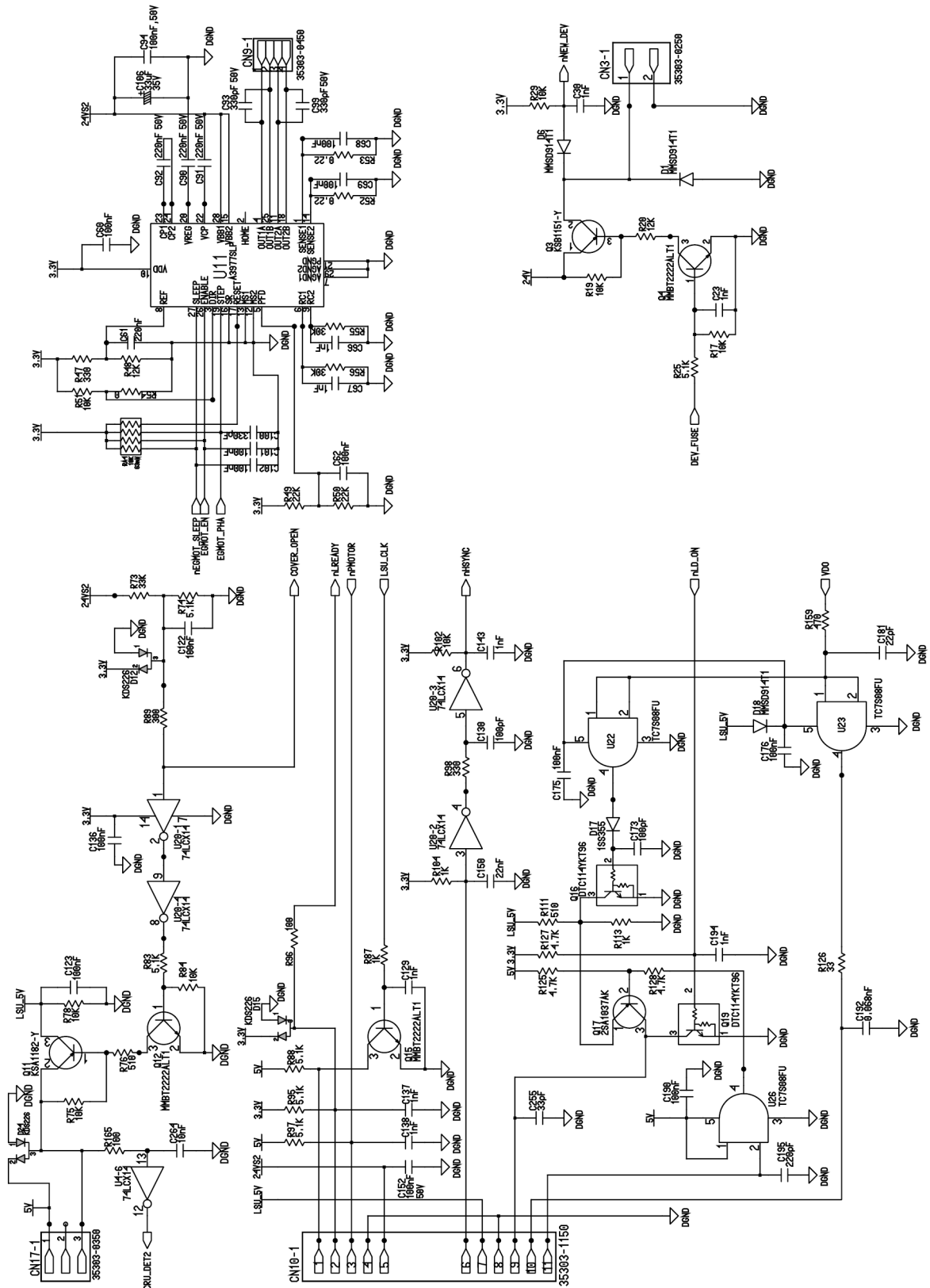

WD 8 Main Board (4/7)

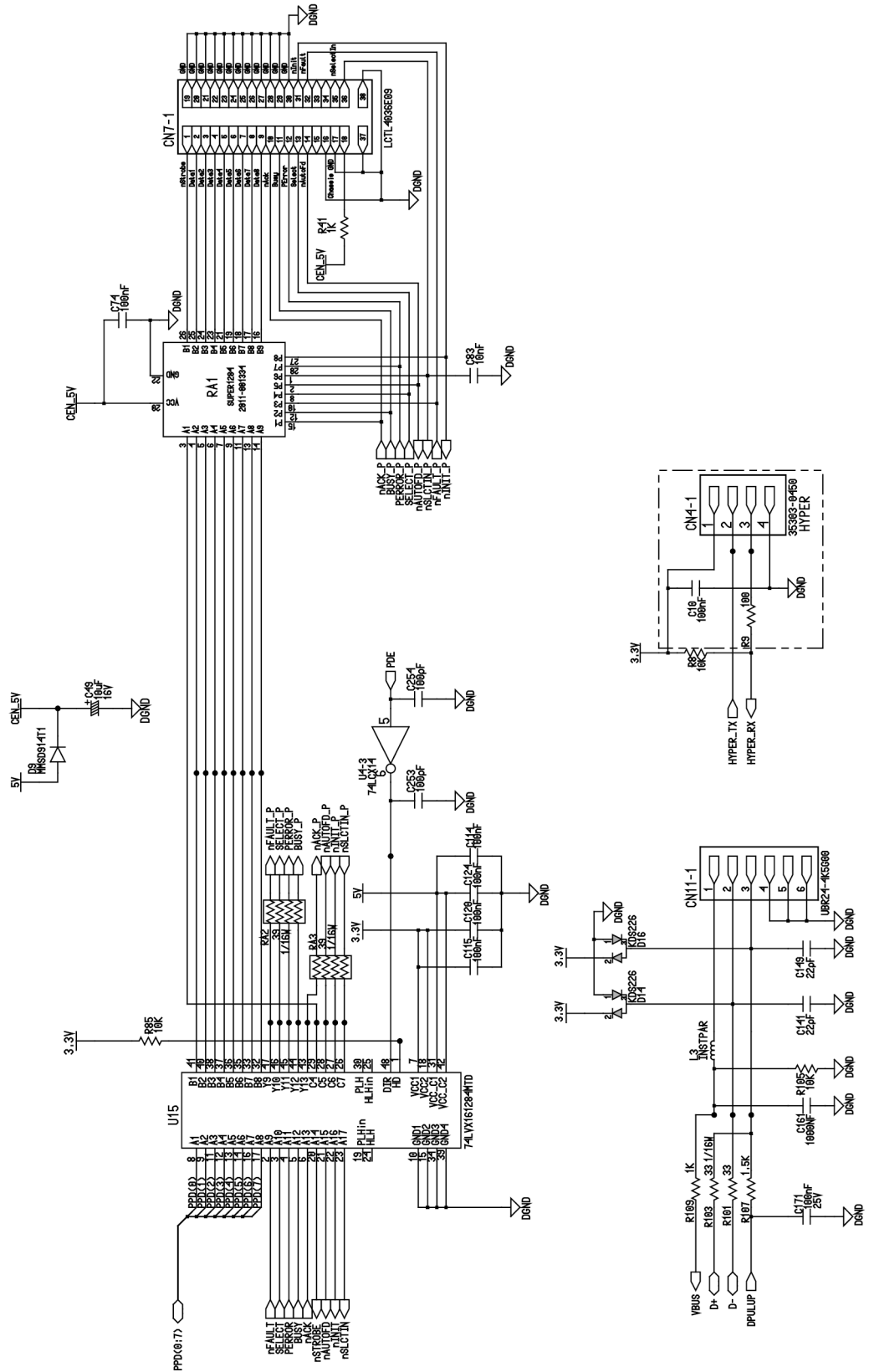

WD 9 Main Board (5/7)

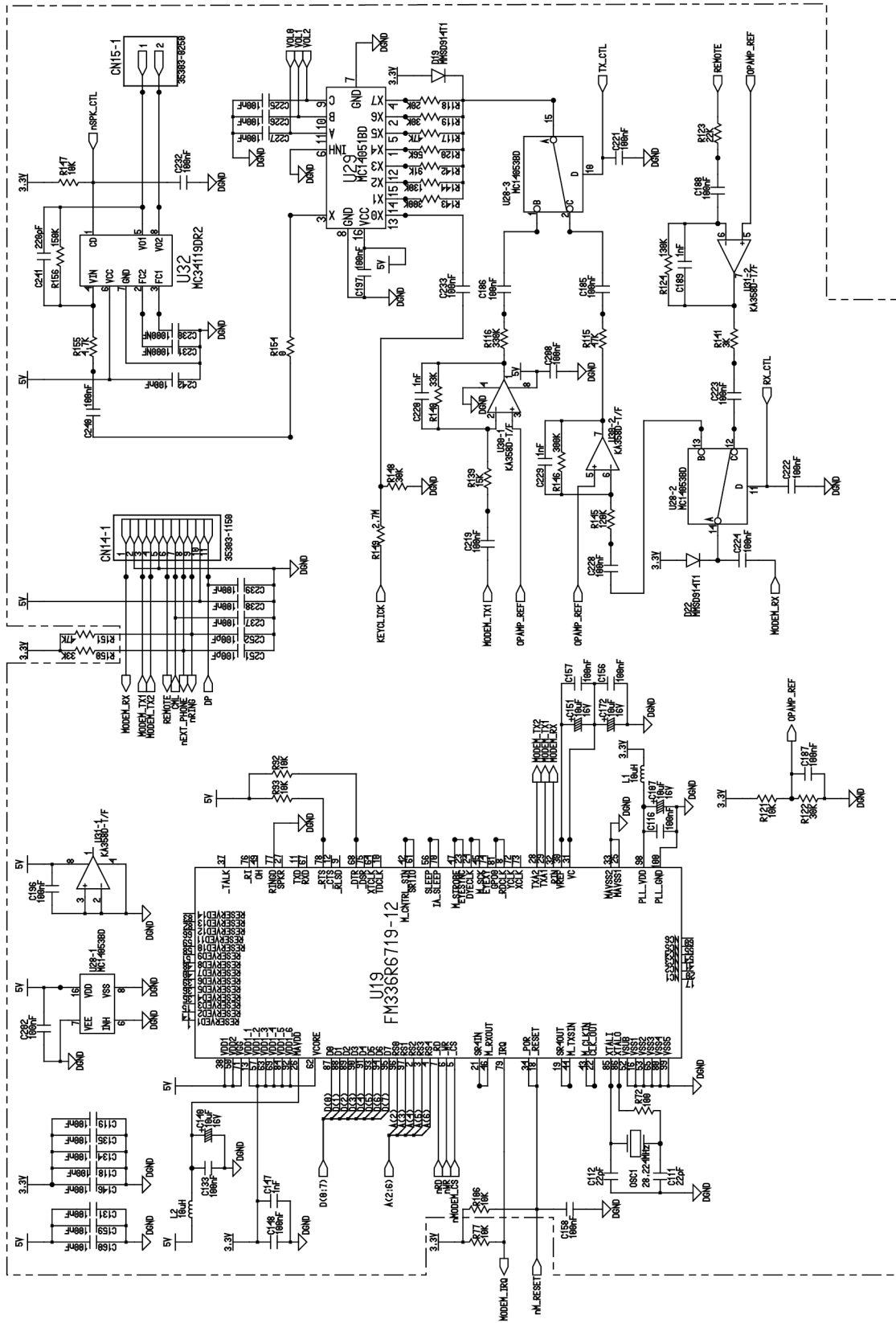

WD 10 Main Board (6/7)

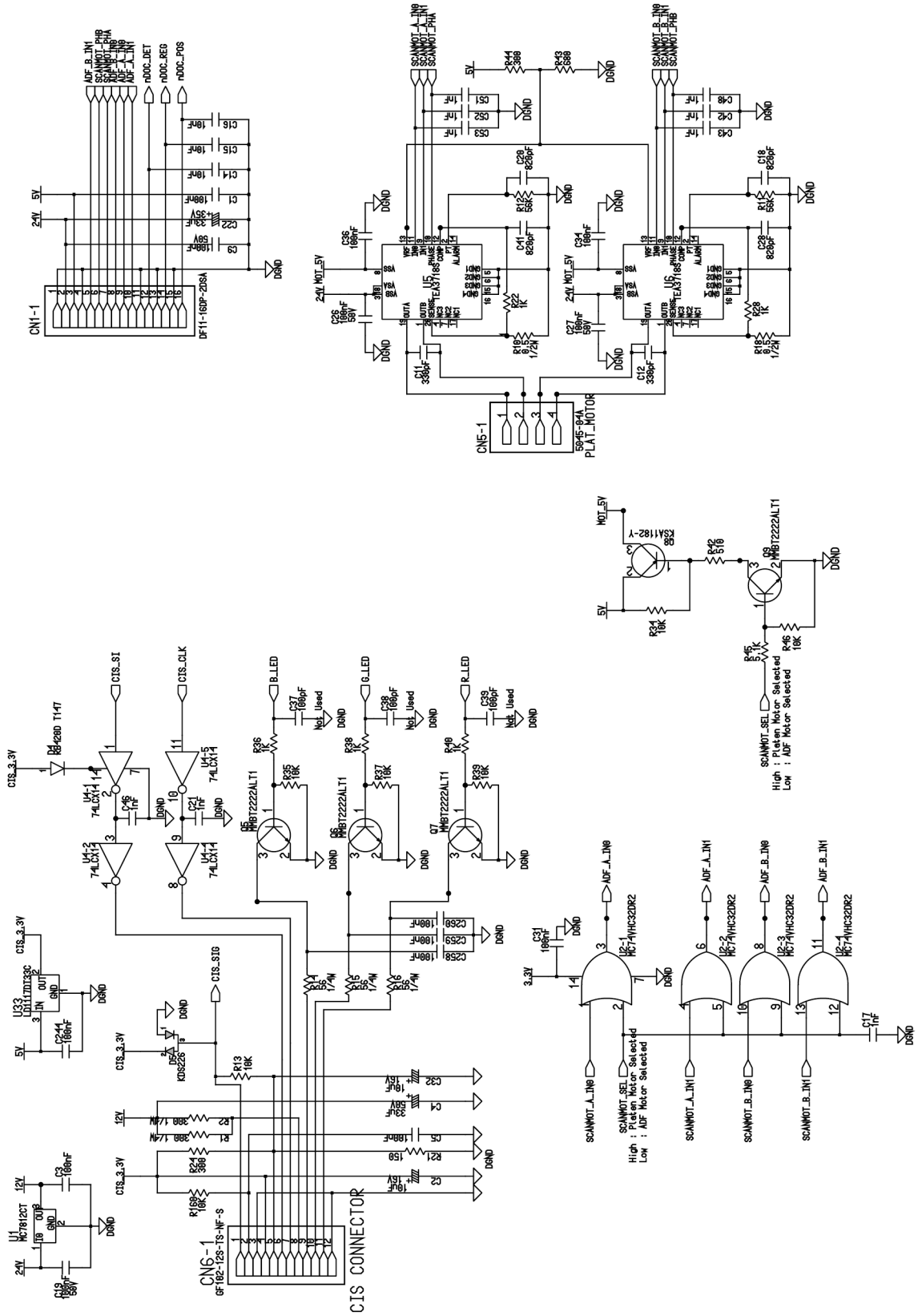

WD 11 Main Board (7/7)

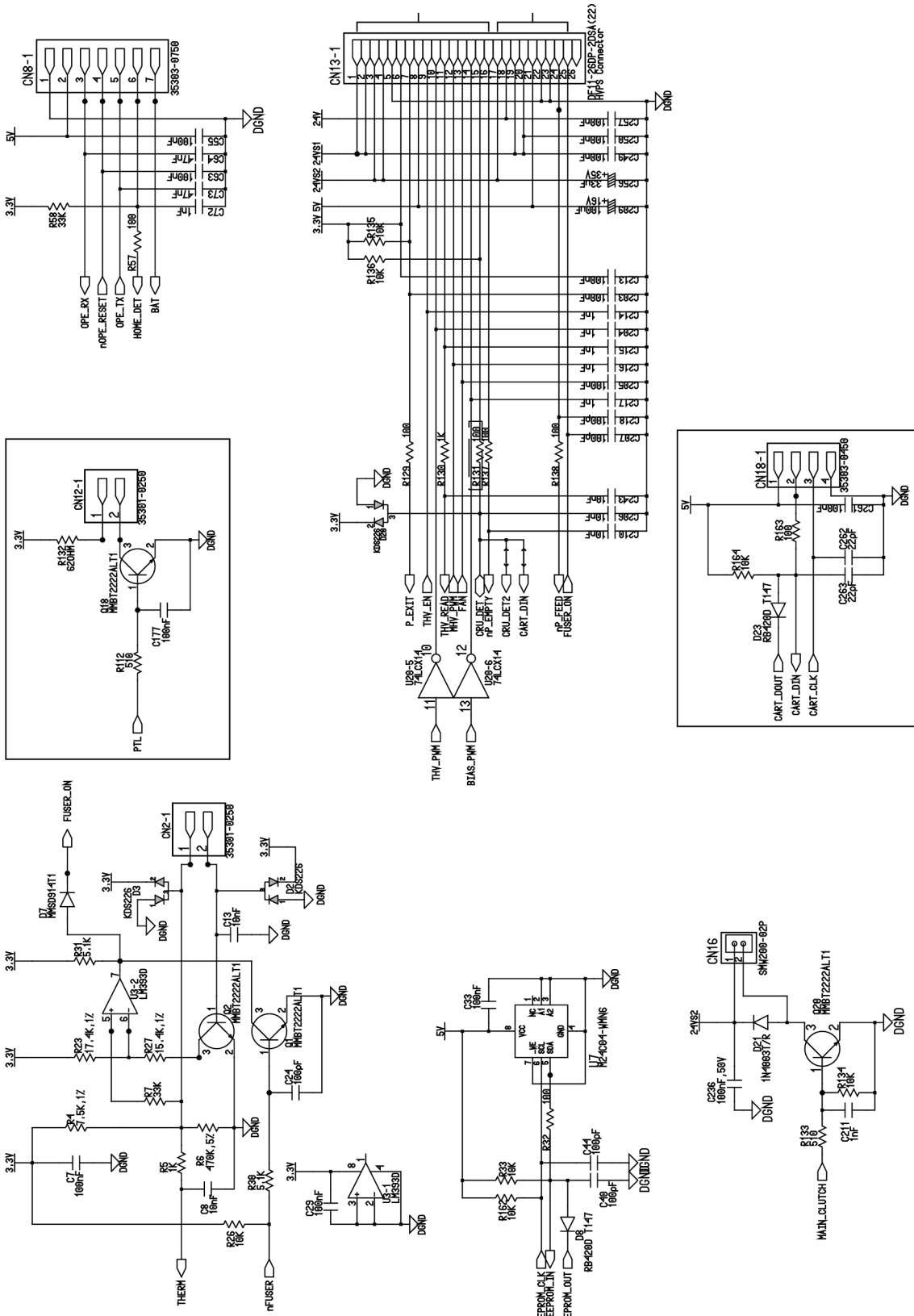

WD 12 LIU

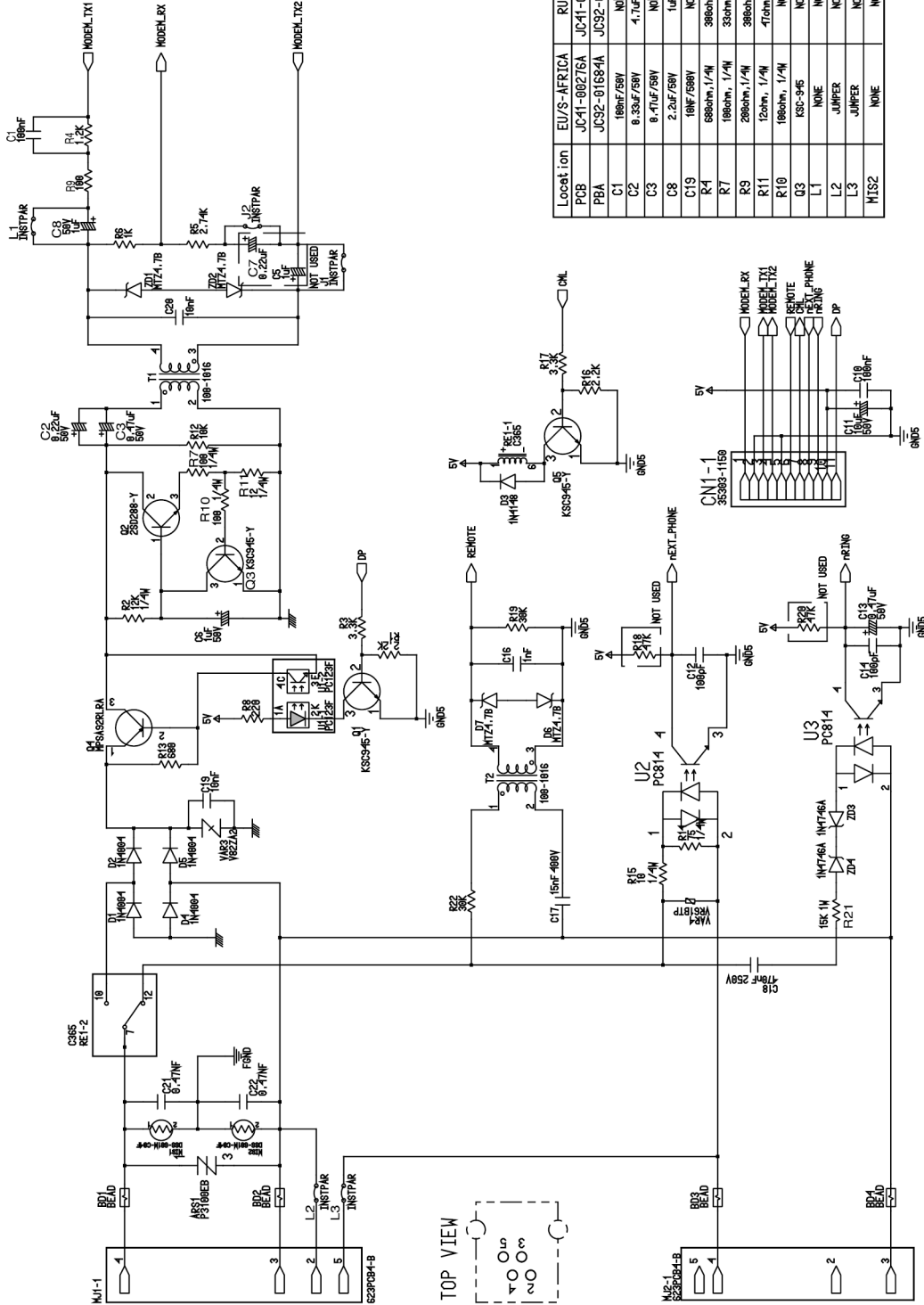

Locat ion	EU/S -AFRICA	RUSSIA	Australia
PCB	JC41-00276A	JC41-00276A	JC41-00276A
PBA	JC92-01584A	JC92-01584B	JC92-01584C
C1	100nF/50V	NONE	100nF/50V
C2	0.33uF/50V	4.7uF/50V	0.22uF/50V
C3	0.47uF/50V	NONE	0.47uF/50V
C8	2.2uF/50V	1uF/50V	0.33uF/50V
C19	10nF/500V	NONE	NONE
R4	680ohm, 1/4W	390ohm, 1/4W	NONE
R7	100ohm, 1/4W	30ohm, 1/4W	30ohm, 1/4W
R9	200ohm, 1/4W	390ohm, 1/4W	100ohm, 1/4W
R11	120ohm, 1/4W	470ohm, 1/4W	470ohm, 1/4W
R10	100ohm, 1/4W	NONE	NONE
C3	K3C-96	NONE	NONE
L1	NONE	NONE	NONE
L2	JUMPER	NONE	NONE
L3	JUMPER	NONE	NONE
MIS2	NONE	NONE	NONE

WD 13 OPE

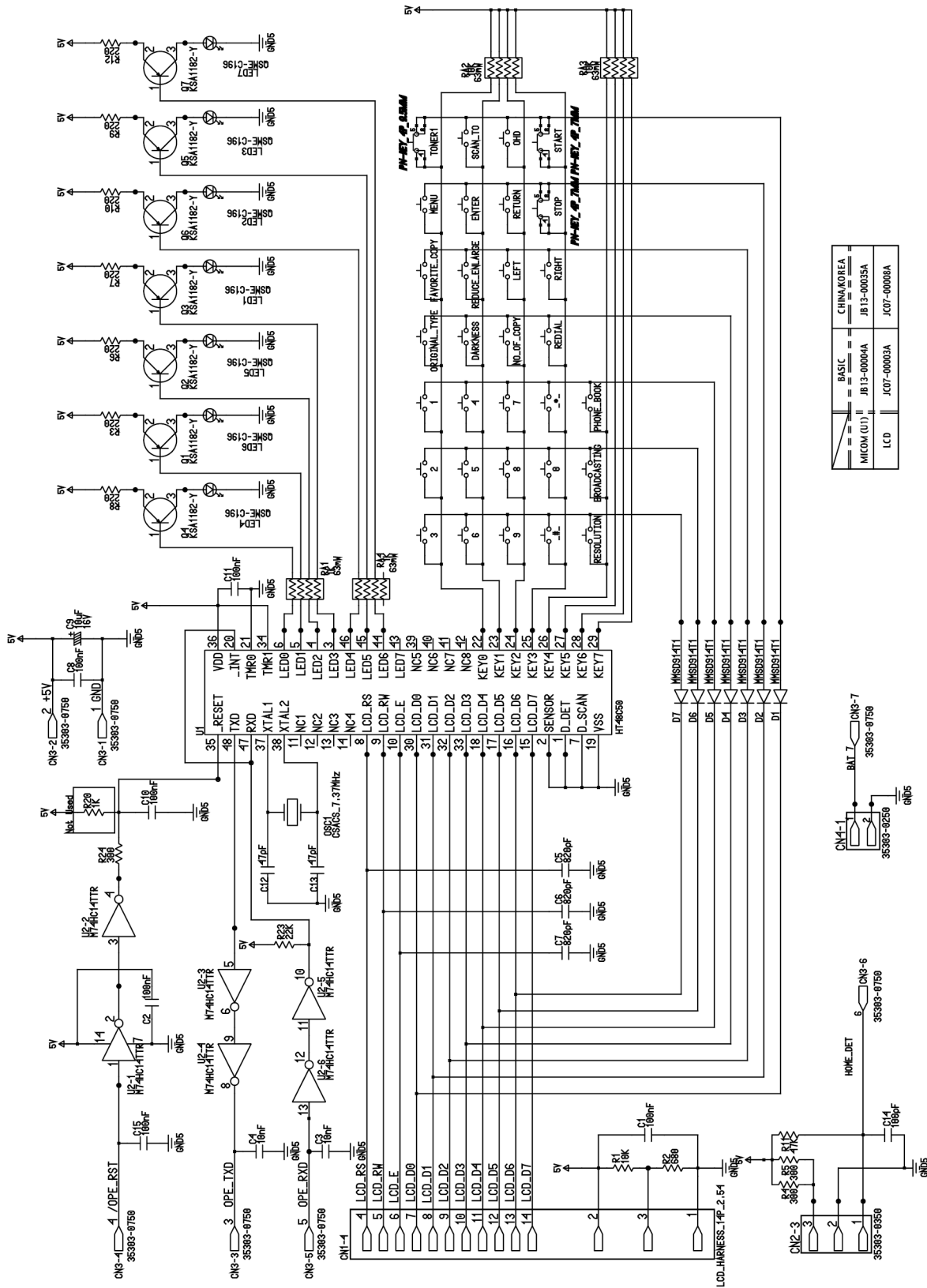

---	BASIC	CHINA KOREA
---	MICOM (U1)	JB13-0004A
---	LCD	JC07-0003A
---		JC07-0008A

WD 16 SMPS

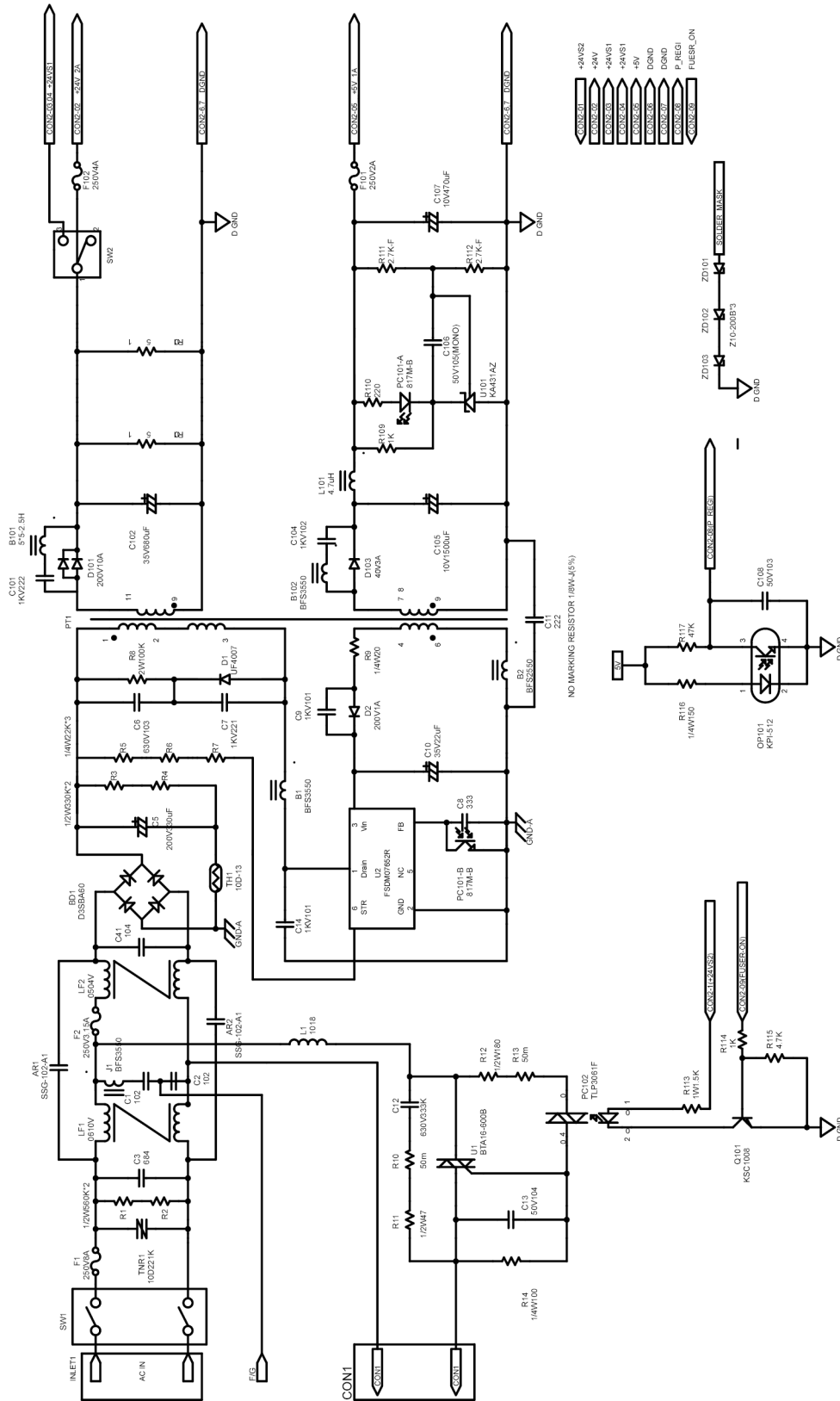

WD 17 HVPS (1/3)

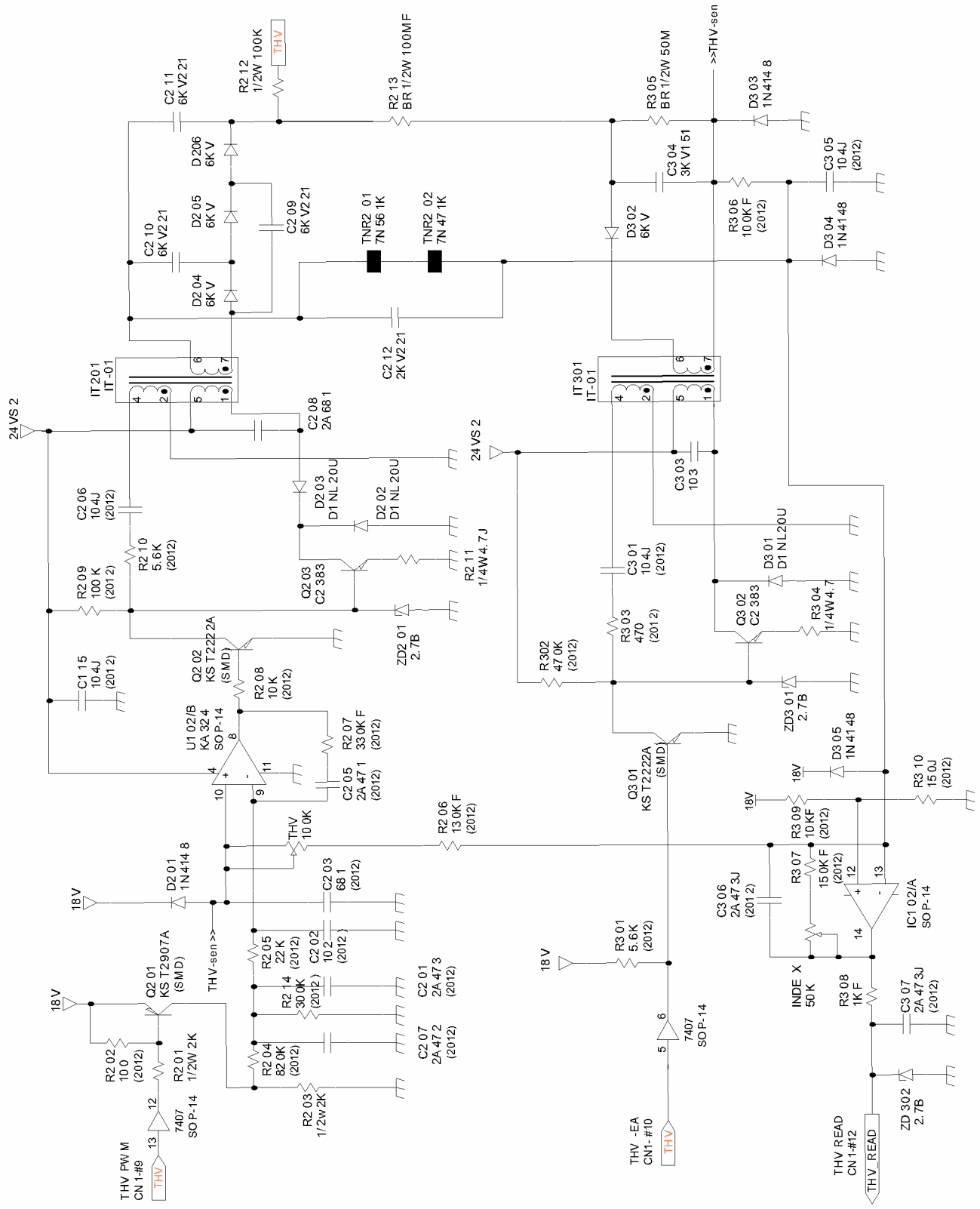

WD 18 HVPS (2/3)

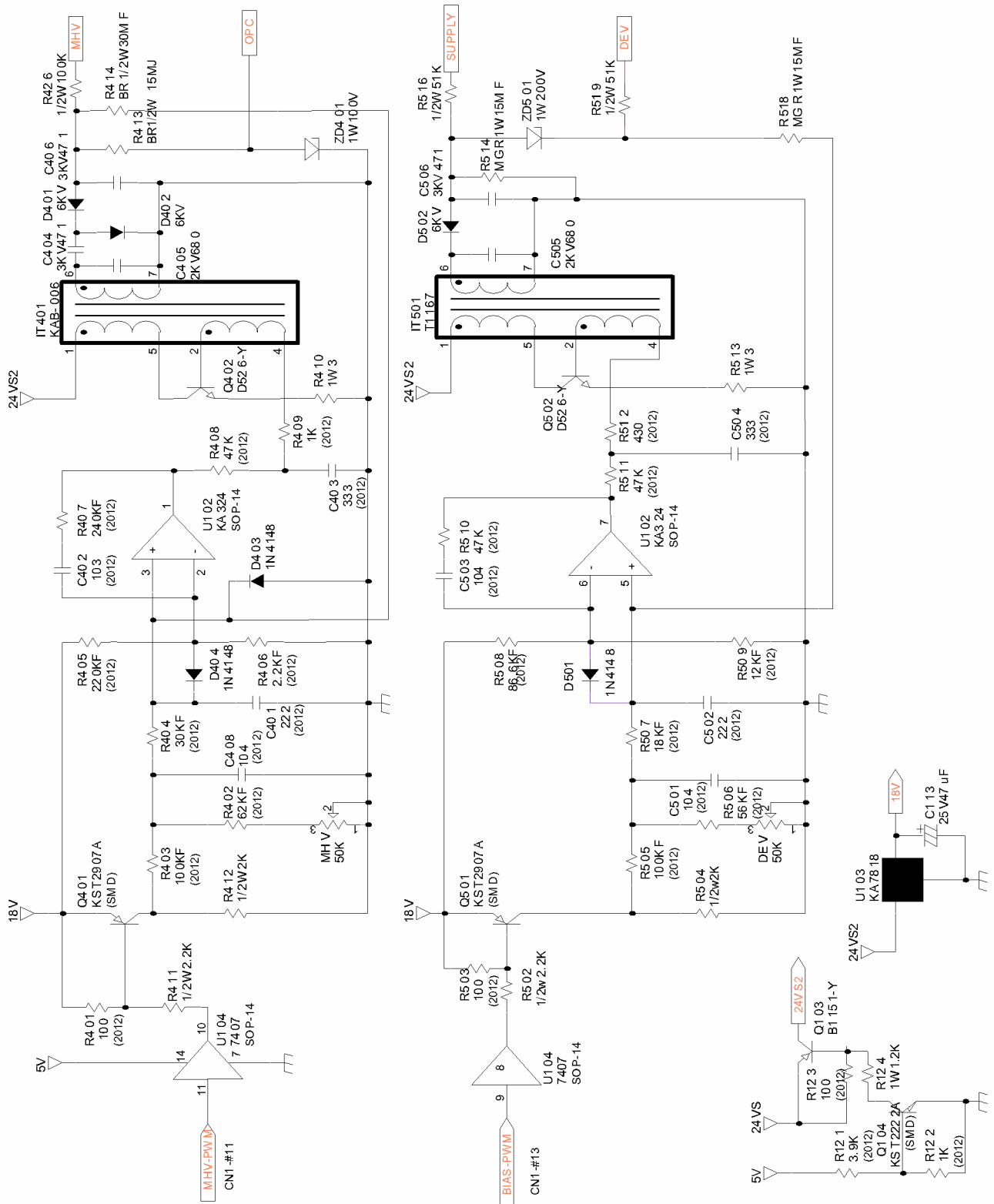

WD 19 HVPS (3/3)

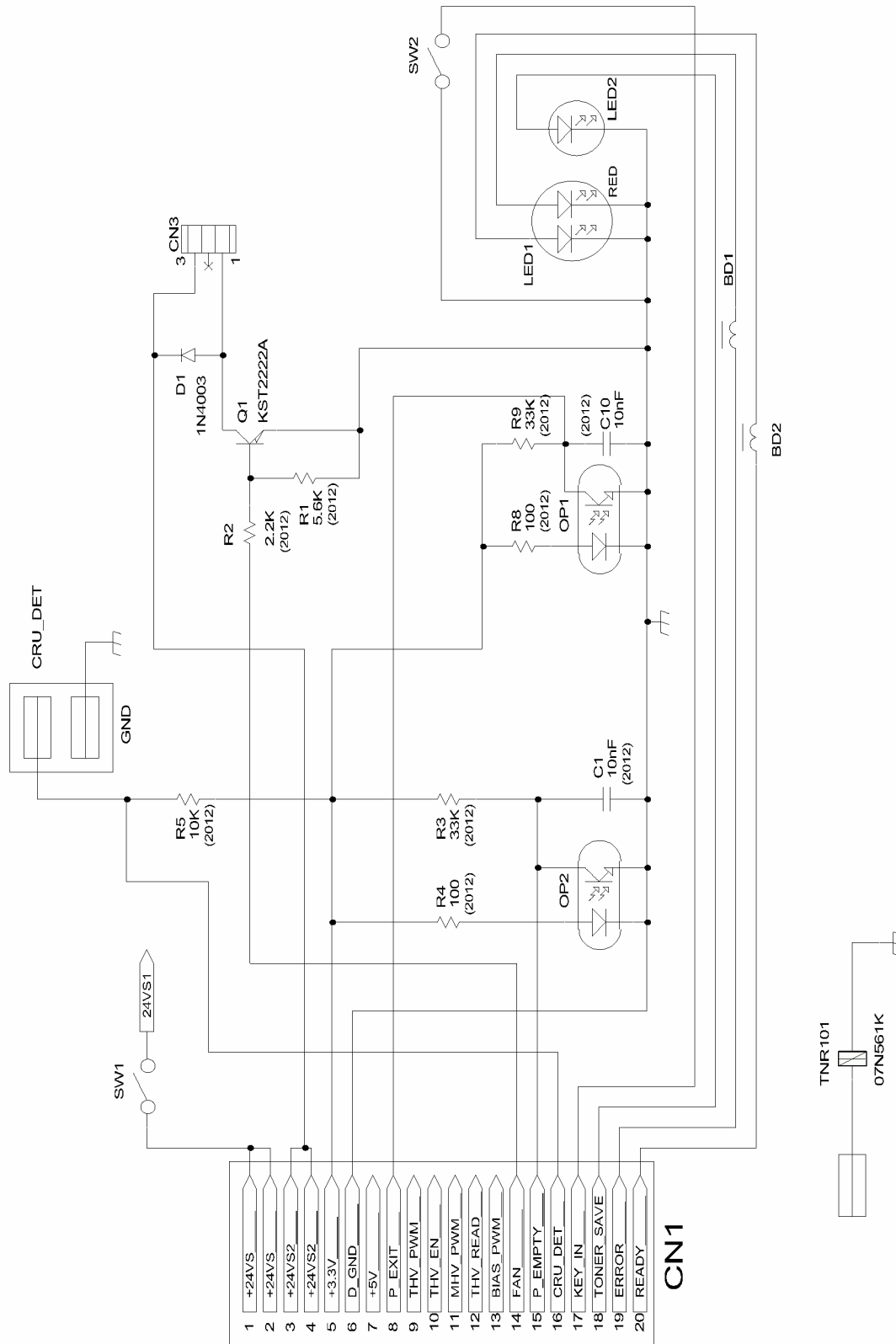

Page intentionally blank



APPENDIX A: Health & Safety Incident Report Involving a Xerox Product

Customer Identification		
Customer Name:		Name of Customer Contact Person:
Address:	E-mail:	Telephone :
		Fax :
Customer Service Engineer Identification		
Name:	Employee :	Pager :
Location:	Phone :	
Details of Incident		
Date Of Incident (mm / dd / yr):		
Description Of Incident: (Check all that apply) <input type="checkbox"/> Excessive Smoke Describe quantity and duration of smoke: <input type="checkbox"/> Fire with open flames seen <input type="checkbox"/> Electric shock to operator or service representative <input type="checkbox"/> Physical injury/illness to operator or service representative Describe: <input type="checkbox"/> Other Describe:		
Any damage to customer property? No <input type="checkbox"/> Yes <input type="checkbox"/> Describe:		
Did external emergency response provider(s) such as fire department, ambulance, and etc. respond? No <input type="checkbox"/> Yes <input type="checkbox"/> Identify: (ie, source, names of individuals)		
Apparent cause of incident (identify part that is suspect to be responsible for the incident)		
Preliminary actions taken to mitigate incident:		



Product Description		
Model No. or Product name:		
Product Serial :	Serial Number(s) of Accessory (ies):	
Installation Date:	Total Copy Meter:	
Date of last service maintenance:		
List damaged and affected part(s) of the machine by description and part number:		
<u>Description</u>	<u>Part Number</u>	
Location of product and affected part(s):		
Individual Providing Notification		
Name:	Title:	Telephone Number:
Organization:		E-Mail:
Mailing Address:		Date Report Submitted:

Instructions: E-mail or fax this completed form to EH&S:

For incidents in **Xerox Europe** and **Developing Markets East**
(Middle East, Africa, India, China, and Hong Kong)
please **e-mail:** Elaine.Grange@gbr.xerox.com or **fax:** +44 (0) 1707 35 3914 [intelnet 8*668 3914]

Note: - If you fax this form, please also send original by internal mail

For incidents in **North America** and **Developing Markets West**
(Brazil, Mexico, Latin American North and Latin American South)
please **e-mail:** Doris.bush@usa.xerox.com or fax 585-422-6449 [Intelnet 8*222-6449]