

ZT111

Industrial Printer



ZEBRA

Service Guide

2022/11/18

ZEBRA and the stylized Zebra head are trademarks of Zebra Technologies Corporation, registered in many jurisdictions worldwide. All other trademarks are the property of their respective owners. ©2022 Zebra Technologies Corporation and/or its affiliates. All rights reserved.

Information in this document is subject to change without notice. The software described in this document is furnished under a license agreement or nondisclosure agreement. The software may be used or copied only in accordance with the terms of those agreements.

For further information regarding legal and proprietary statements, please go to:

SOFTWARE: zebra.com/linkoslegal.

COPYRIGHTS: zebra.com/copyright.

PATENTS: ip.zebra.com.

WARRANTY: zebra.com/warranty.

END USER LICENSE AGREEMENT: zebra.com/eula.

Terms of Use

Proprietary Statement

This manual contains proprietary information of Zebra Technologies Corporation and its subsidiaries ("Zebra Technologies"). It is intended solely for the information and use of parties operating and maintaining the equipment described herein. Such proprietary information may not be used, reproduced, or disclosed to any other parties for any other purpose without the express, written permission of Zebra Technologies.

Product Improvements

Continuous improvement of products is a policy of Zebra Technologies. All specifications and designs are subject to change without notice.

Liability Disclaimer

Zebra Technologies takes steps to ensure that its published Engineering specifications and manuals are correct; however, errors do occur. Zebra Technologies reserves the right to correct any such errors and disclaims liability resulting therefrom.

Limitation of Liability

In no event shall Zebra Technologies or anyone else involved in the creation, production, or delivery of the accompanying product (including hardware and software) be liable for any damages whatsoever (including, without limitation, consequential damages including loss of business profits, business interruption, or loss of business information) arising out of the use of, the results of use of, or inability to use such product, even if Zebra Technologies has been advised of the possibility of such damages. Some jurisdictions do not allow the exclusion or limitation of incidental or consequential damages, so the above limitation or exclusion may not apply to you.

Contents

Troubleshooting.....	5
Barcode Will Not Scan and Other Print Quality Issues.....	5
Incorrect Printer Settings.....	7
Repair Flowcharts.....	17
Failure to Power Up.....	17
Label Will Not Feed.....	18
Persistent Media Out Error.....	19
Persistent Ribbon In/Out Error.....	20
Printhead Open Errors.....	21
Other Printhead Errors.....	22
Cutter Errors.....	23
Wired Print Server Errors.....	24
Wireless Print Server Errors.....	25
Servicing the Printer through Zebra Repair.....	25
Shipping the Printer.....	25
Diagnostic Tools, Tests, and Procedures.....	26
Indicator Lights.....	26
Configuration Labels.....	29
PAUSE Self Test.....	30
Sensor Profile.....	31
Communication Diagnostics Test.....	32
Loading Defaults or Last Saved Values.....	34
Calibrating the Ribbon and Media Sensors.....	35
Performing Auto Calibration.....	35

Performing Manual Calibration.....35

Routine Maintenance..... 39

- Cleaning Schedule and Procedures.....39
 - Cleaning the Exterior, the Media Compartment, and the Sensors.....40
 - Cleaning the Printhead and Platen Roller.....40
 - Cleaning the Peel Assembly.....43
 - Cleaning and Lubricating the Cutter Module.....46
- Removing Used Ribbon..... 53
- Replacing Printer Components..... 54
 - Ordering Replacement Parts..... 54
 - Recycling Printer Components.....54
- Lubrication.....54

Replacement Parts and Options..... 55

- Outer Casing..... 55
- Print Mechanism..... 57
- Electronics..... 60
- Sensors.....64
- Drive System..... 64
- Media Path..... 65
- Media Handling Options..... 67
- Hardware and Packaging..... 69

Troubleshooting

This section is designed for technicians or other users who need to service the printer. When applicable, you are instructed which parts to replace.

For basic troubleshooting information, see the [User Guide](#).

See Also

[Print Quality Issues](#)

[Repair Flowcharts](#)

[Servicing the Printer through Zebra Repair](#)

[Diagnostics](#)

[Routine Maintenance](#)

[Replacement Parts](#)

Barcode Will Not Scan and Other Print Quality Issues

Issues with print quality, such as voids in the print or barcodes that will not scan, can be caused by a number of things. Use the recommendations in this section to troubleshoot and resolve the issues.

Print Quality Issues typically are caused by one of the following:

A dirty or damaged printhead

- [Clean the printhead](#).
- If the printhead is damaged, replace it. Go to [Print Mechanism](#) on page 57 for the part number or to <https://www.zebra.com/parts> for ordering information.

Incorrect printer parameter settings

Follow the steps [in this section](#) to determine if printer settings are causing print quality issues.

Printer adjustment needed

See [this section](#) for possible adjustments to make.

Wrinkled ribbon

Check that ribbon is loaded correctly. Refer to the [User Guide](#) for instructions.

Media issues

- The direct thermal media being used is old. Try using a new roll or a roll from a printer that is working correctly to see if the problem still exists.
- There is a mismatch between the ribbon and media being used. Did you change suppliers recently? The quality or compatibility may not be the same from roll to roll. Experiment with what you have to see if any combinations produce acceptable results.

See zebra.com/supplies for media and ribbon ordering information.

Label or barcode design issues

Check the label format. Leave at least 3.2 mm (1/8 in.) between the barcode and other printed areas on the label and between the barcode and the edge of the label.

Environmental issues

Check the label for degradation.

- Is the label clean?
- Are the barcodes damaged or the text too smudged to read?
- If you are in a harsh environment and are using Direct Thermal labels, consider switching to Thermal Transfer labels for better results.

Incorrect Printer Settings

Incorrect settings can come from sources such as the printer, the driver, and the label format itself. If you change settings in one area and they change back, look into the other sources.

Begin troubleshooting by running the FEED self-test to generate an appropriate label that you can use to [evaluate print and barcode quality](#).

Evaluating Barcode Quality

Different types of media may require different darkness settings. This section contains a simple but effective method for determining the ideal darkness for printing barcodes that are within specifications.

During the FEED self test, labels are printed at different darkness settings at two different print speeds. The relative darkness and the print speed are printed on each label. The barcodes on these labels may be ANSI-graded to check print quality.

During this test, one set of labels is printed at 2 ips, and another set is printed at 6 ips. The darkness value starts at three settings lower than the printer's current darkness value (relative darkness of -3) and increase until the darkness is three settings higher than the current darkness value (relative darkness of +3).

1. Print a configuration label to show the printer's current settings. (See [Configuration Labels](#) on page 29.)
2. Turn off (O) the printer.

have a barcode verifier, use your eyes or the system scanner to choose the optimal darkness setting based on the labels printed in this self test.

Figure 2 Evaluating Barcode Quality



Appearance	Description
Too dark labels	<p>Fairly obvious. These may be readable but are not “in-spec.”</p> <ul style="list-style-type: none"> The normal barcode bars increase in size. The openings in small alphanumeric characters may fill in with ink. Rotated barcode bars and spaces run together.
Slightly dark labels	<p>Not as obvious as the too-dark labels.</p> <ul style="list-style-type: none"> The normal barcode will be “in-spec.” Small alphanumeric characters will be bold, and may appear slightly filled in. The rotated barcode spaces are small when compared to the “in-spec” code, possibly making the code unreadable.

Appearance	Description
“In-spec” labels	<p>Whether or not a label is “in-spec” can only be confirmed by a verifier, but they typically exhibit some visible characteristics.</p> <ul style="list-style-type: none"> • The normal barcode will have complete, even bars along with clear, distinct spaces. • The rotated barcode will have complete, even bars along with clear, distinct spaces. Although it may not look as good as a slightly dark barcode, the barcode will be “in-spec.” • In both normal and rotated styles, small alphanumeric characters will look complete.
Slightly light labels	<p>In some cases, these are preferred to slightly dark ones for “in-spec” barcodes.</p> <ul style="list-style-type: none"> • Both normal and rotated barcodes will be “in-spec,” but small alphanumeric characters may not be complete.
Too light labels	<p>These are obvious.</p> <ul style="list-style-type: none"> • Both normal and rotated barcodes have incomplete bars and spaces. • Small alphanumeric characters are unreadable.

5. Note the relative darkness value and the print speed printed on the best test label.
6. Add or subtract the relative darkness value from the darkness value specified on the configuration label. The resulting numeric value is the optimal darkness value for that specific label/ribbon combination and print speed.
7. If necessary, change the darkness value to the darkness value on the selected test label.
8. If necessary, change the print speed to the same speed as on the selected test label.

See Also

[Print Settings](#)

Printer Adjustments Sometimes Needed

Making certain adjustments can sometimes help with printing or print quality issues.

Printhead pressure

You may need to [adjust printhead pressure](#) if printing is too light on one side, if you use thick media, or if the media drifts from side to side during printing. Use the lowest printhead pressure necessary to produce good print quality.

Media guides

If you experience loss of printing registration or excessive vertical drift in top-of-form registration, check the position of the media guides. The guides should just touch the edge of the media without causing any distortion. Refer to the [User Guide](#) for media loading instructions.

Ribbon tension

For the printer to operate correctly, the ribbon supply spindle and ribbon take-up spindle must use the same tension setting (normal or low tension). Use the normal tension setting for most applications. If you are using narrow ribbon or experience certain ribbon issues, you may need to [lower the ribbon tension](#).

Platen roller housing

If the printer displays a variation in print density from one side of the label to another with the printhead pressure applied evenly, the [platen roller housing](#) may need adjustment.

Adjusting the Printhead Pressure

You may need to adjust printhead pressure if printing is too light on one side, if you use thick media, or if the media drifts from side to side during printing. Use the lowest printhead pressure necessary to produce good print quality.

The printhead pressure adjustment dials have setting marks from 1 to 4 in half-mark increments.

Figure 3 Printhead Pressure Adjustment Dials

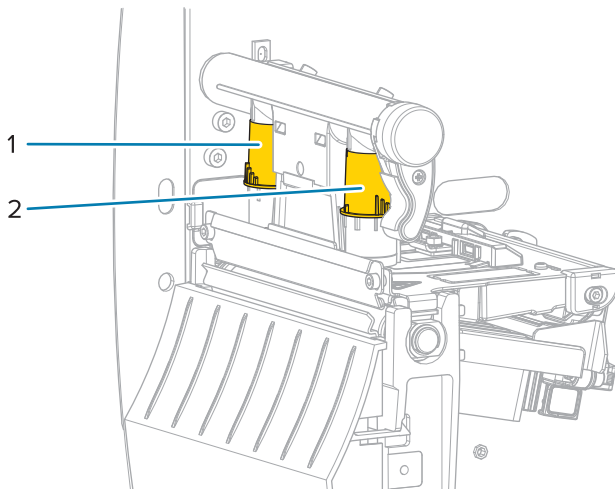

1	Inside dial
2	Outside dial

Begin with the following pressure settings based on your media width, and then make adjustments if necessary.

Table 1 Starting Points for Printhead Pressure

Media Width	Inside Dial Setting	Outside Dial Setting
≥ 89 mm (≥ 3.5 in.)	2	2
76 mm (3 in.)	2.5	1.5
51 mm (2 in.)	3	1
25 mm (1 in.)	4	1

If necessary, adjust the printhead pressure adjustment dials as follows:

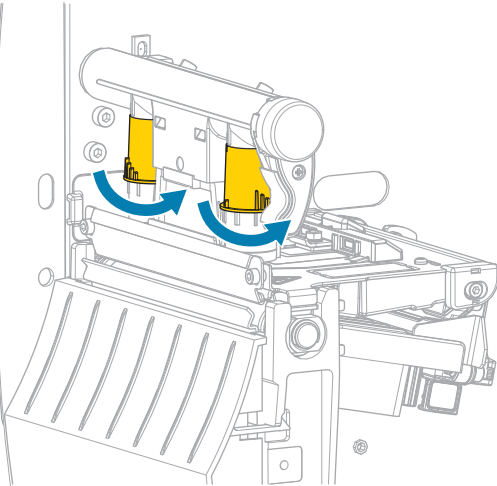
If the Media...	Then...
Requires higher pressure to print well	<p>Increase both dials one position.</p> 

Troubleshooting

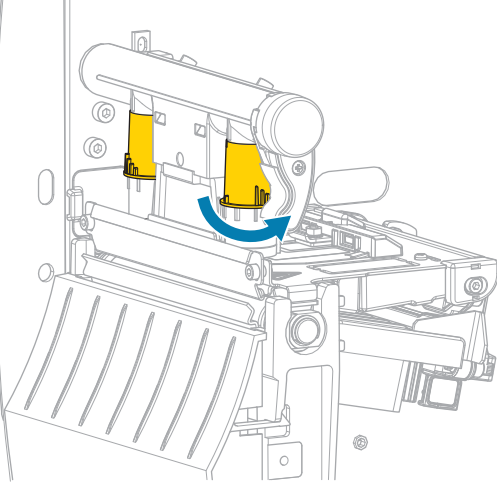
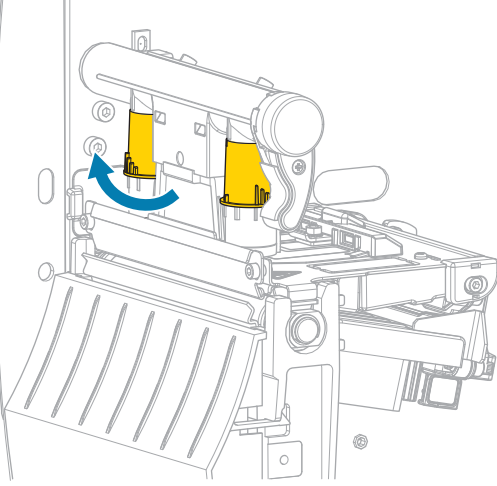
If the Media...	Then...
Shifts left while printing	<p data-bbox="548 247 1075 279">Increase the outside dial setting one position.</p>  <p data-bbox="548 783 587 814">OR</p> <p data-bbox="548 825 1075 856">Decrease the inside dial setting one position.</p> 

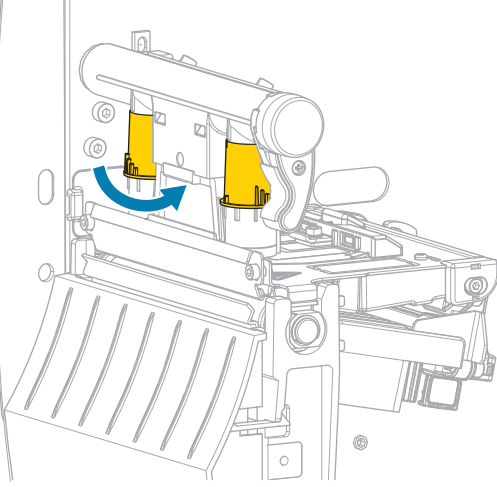
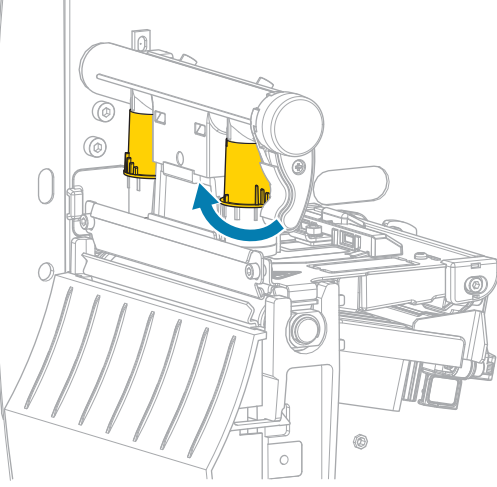
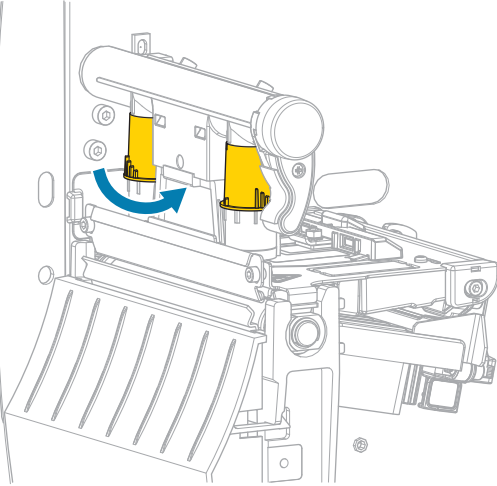
If the Media...	Then...
<p>Shifts right while printing</p>	<p>Increase the inside dial setting one position.</p>  <p>OR</p> <p>Decrease the outside dial setting one position.</p> 
<p>Prints too lightly on the left side of the label.</p>	<p>Increase the inside dial setting one position.</p> 

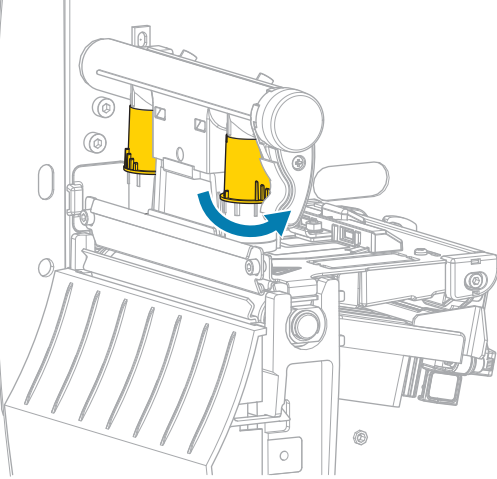
If the Media...	Then...
Prints too lightly on the right side of the label.	<p>Increase the outside dial setting one position.</p> 

Adjusting Ribbon Tension

For the printer to operate correctly, the ribbon supply spindle and ribbon take-up spindle must use the same tension setting (normal or low tension). Use the normal tension setting seen here for most applications. If you are using narrow ribbon or experience certain ribbon issues, you may need to lower the ribbon tension.

Normal Tension Setting

To place the ribbon spindles in the normal position, firmly pull out each spindle end cap until it extends and clicks in place. Use this setting for most applications.

Figure 4 Normal Tension Setting (Spindle End Caps Pulled Out)

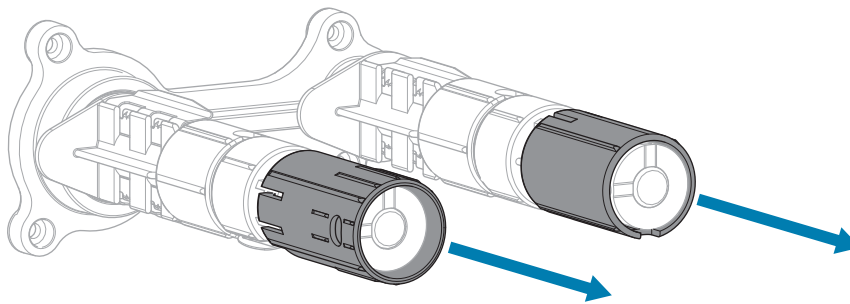

Low Tension Setting

To place a spindle in the low-tension position, firmly push in the end cap until it retracts and clicks in place. Use this setting only when necessary, such as if the ribbon causes scuff marks at the beginning of a roll or if normal tension causes the ribbon to stall at the end of the roll.

Figure 5 Ribbon Spindles— Low Tension Setting (Spindle End Caps Pushed In)

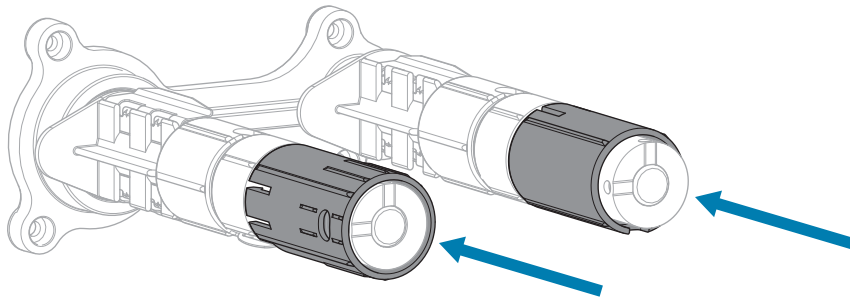

Adjusting the Platen Roller Housing

If the print is too light on one side with the printhead pressure applied evenly, the platen roller housing may need slight adjustment.

1. Print **PAUSE** self-test labels at low darkness to see if there is a variation in print density.

- a) Note the starting darkness value.
- b) Lower the darkness until the print is light gray.
- c) Turn off (O) the printer.
- d) Press and hold **PAUSE** while turning on (I) the printer. Hold **PAUSE** until the first control panel light turns off.

The initial self-test prints 15 labels at the printer's slowest speed, and then automatically pauses the printer. Each time **PAUSE** is pressed, an additional 15 labels print.

2. Is the print darker on one side of the label?

- If no, the platen roller housing does not need adjusting. Press and hold **CANCEL** to exit the self-test.
- If yes, loosen (but do not remove) the screw that attaches a bracket to the bottom of the platen roller housing.

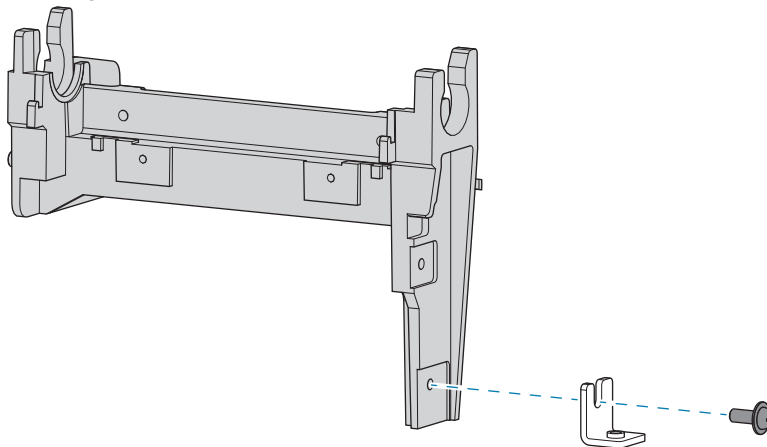

If the print was lighter on the outboard side of the media, put light upward pressure on the platen roller housing, and then tighten the screw.

If the print was lighter on the inboard side of the media, put light downward pressure on the platen roller housing, and then tighten the screw.

3. Press **PAUSE** to print additional labels, and check the print density.
 - If the density is consistent across the label, the adjustment was successful.
 - If print still is darker at one side of the label, repeat the adjustment to the platen roller housing until the density is consistent.
4. Press and hold **CANCEL** to exit the self-test.
5. Set the darkness to the starting value noted in the first step.

Repair Flowcharts

Failure to Power Up

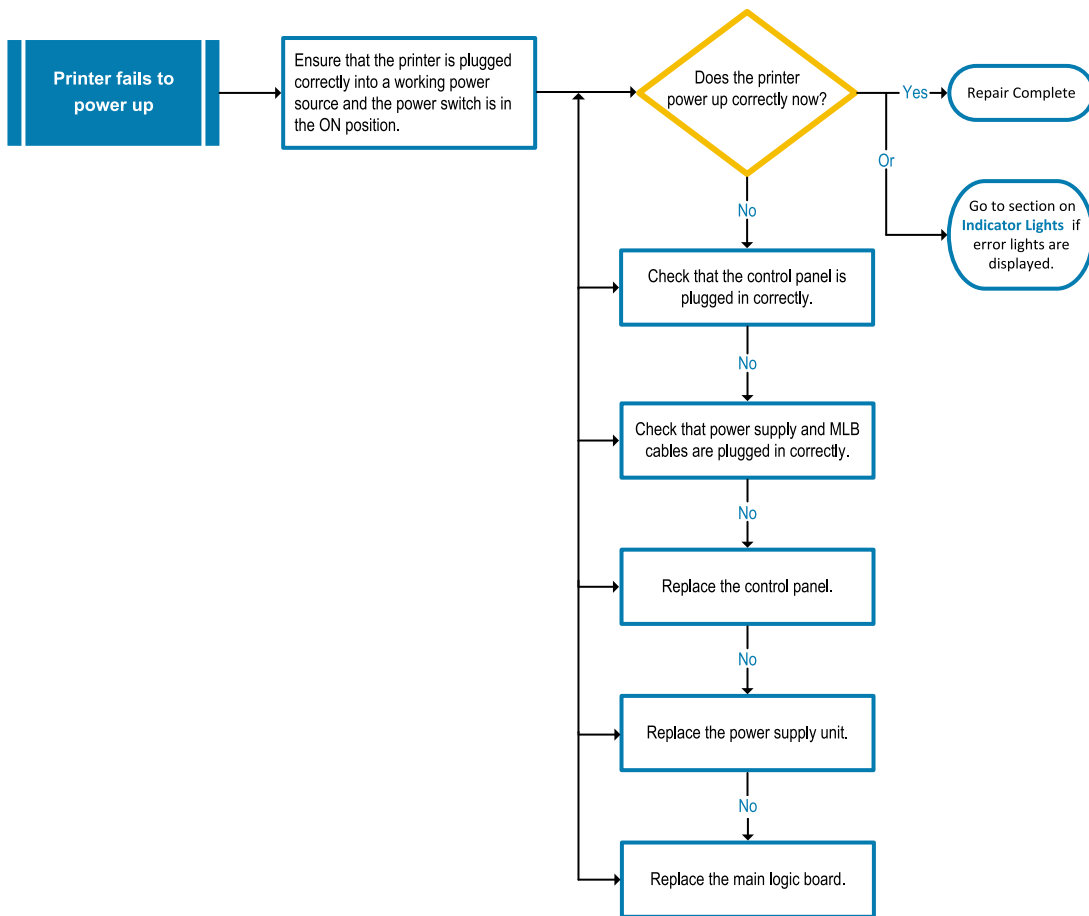

Label Will Not Feed

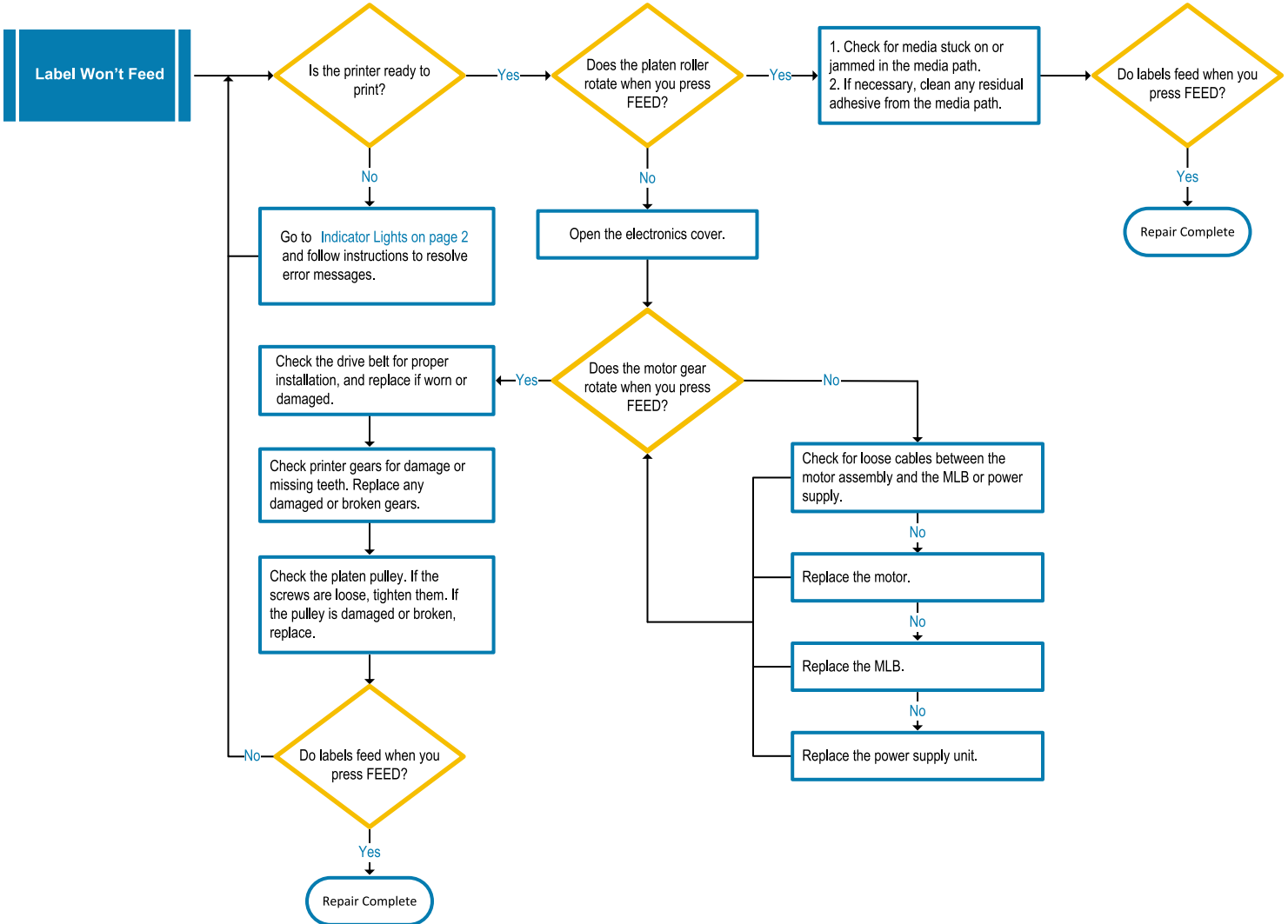

Persistent Media Out Error

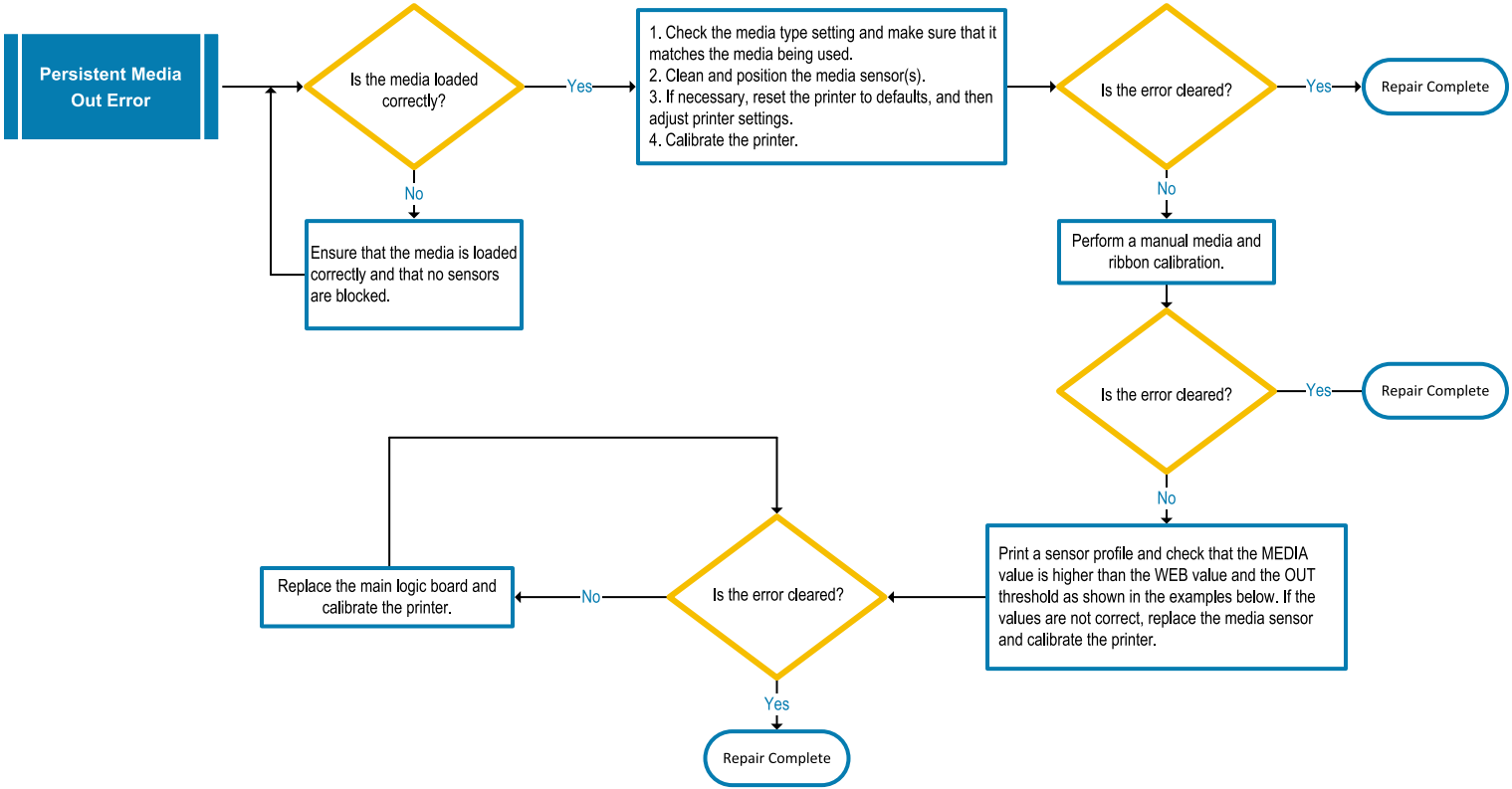

Figure 6 Media Sensor Profile (Gap/Notch Media)

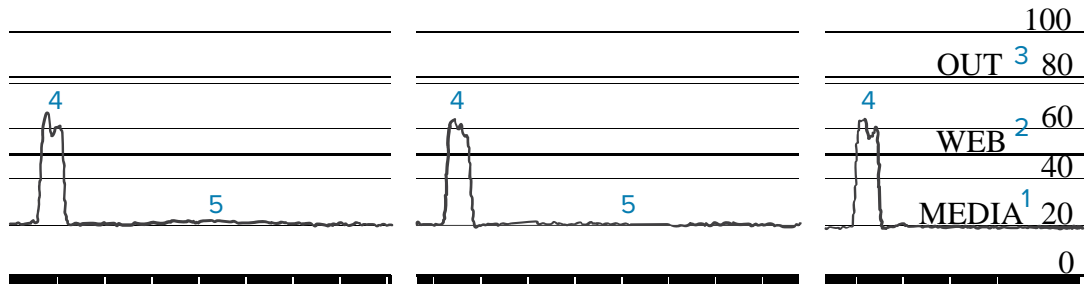
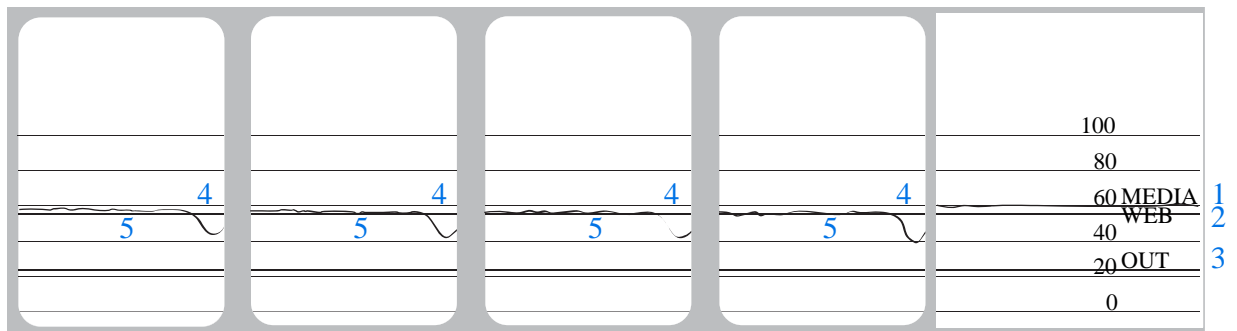

Figure 7 Media Sensor Profile (Black Mark Media)



Persistent Ribbon In/Out Error

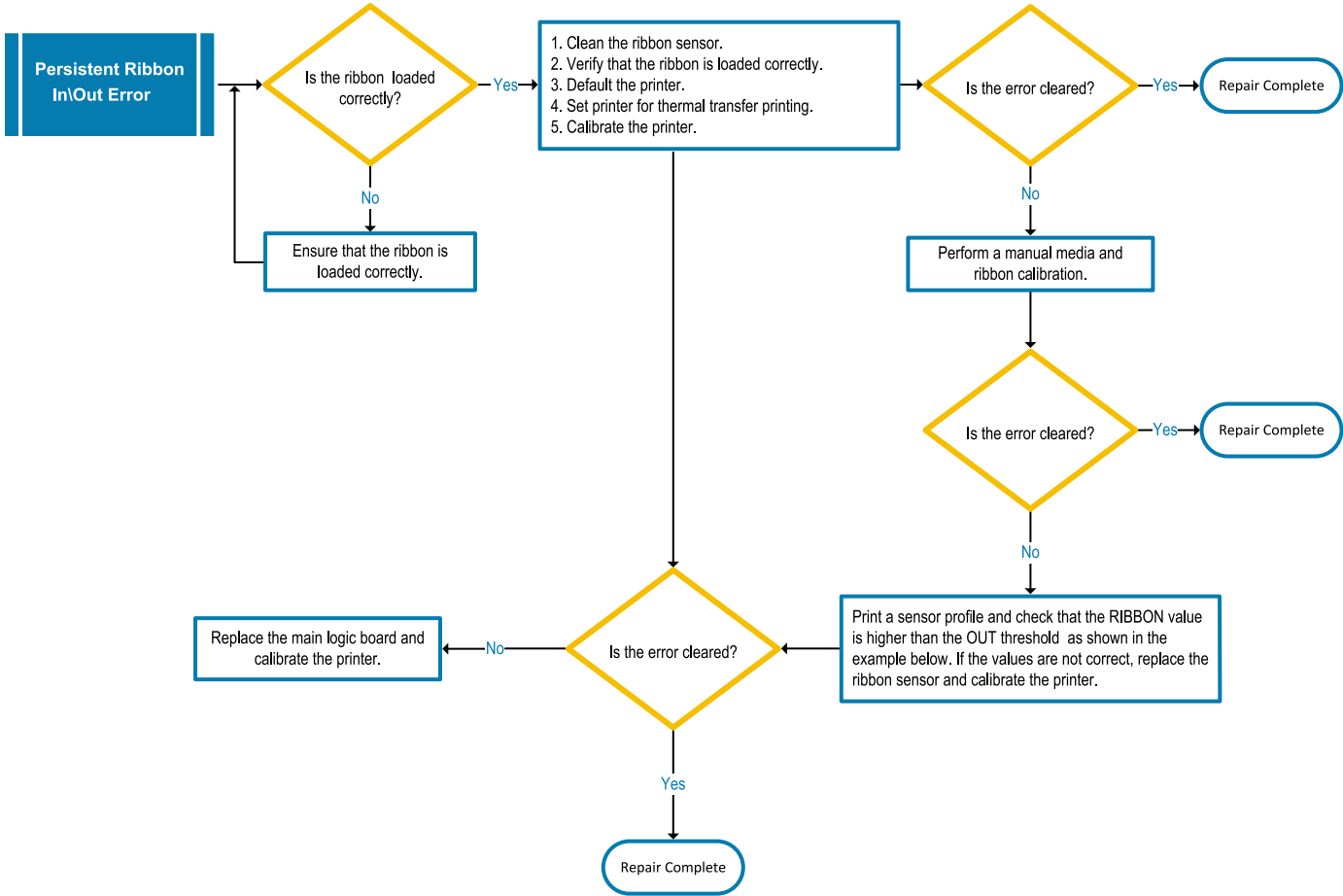
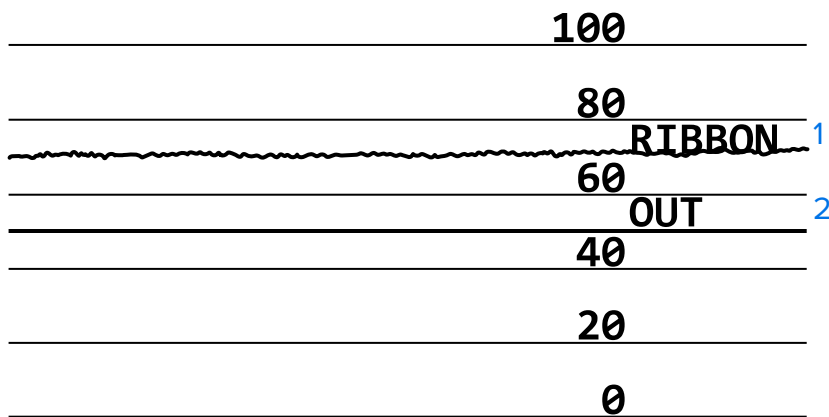
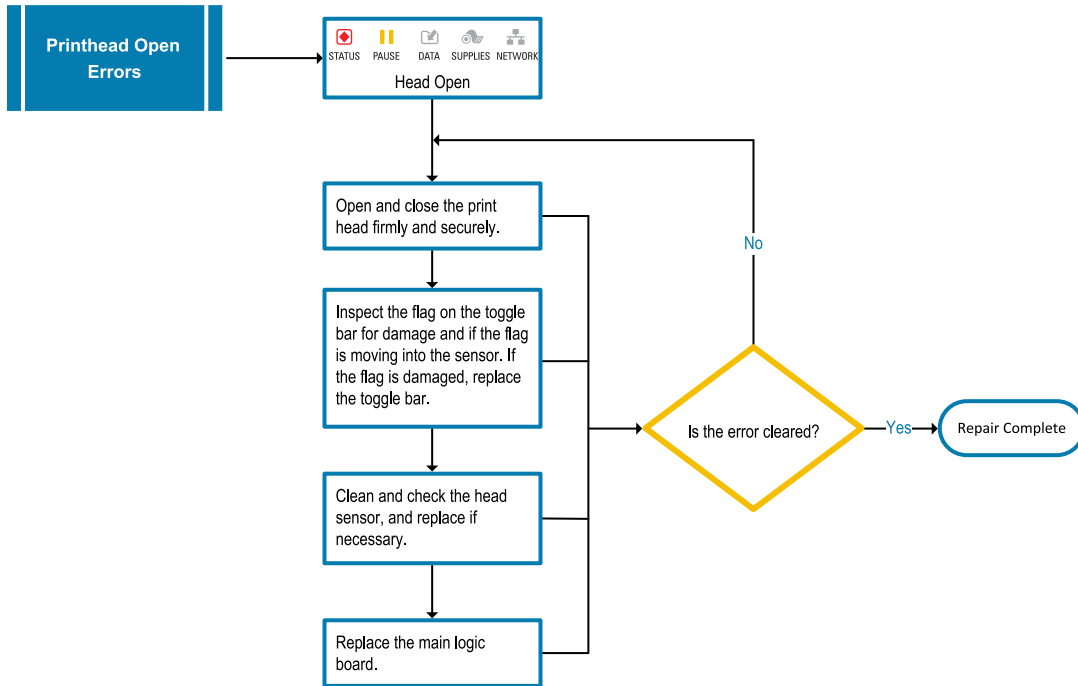

Figure 8 Sensor Profile (Ribbon Section)



Printhead Open Errors



Other Printhead Errors

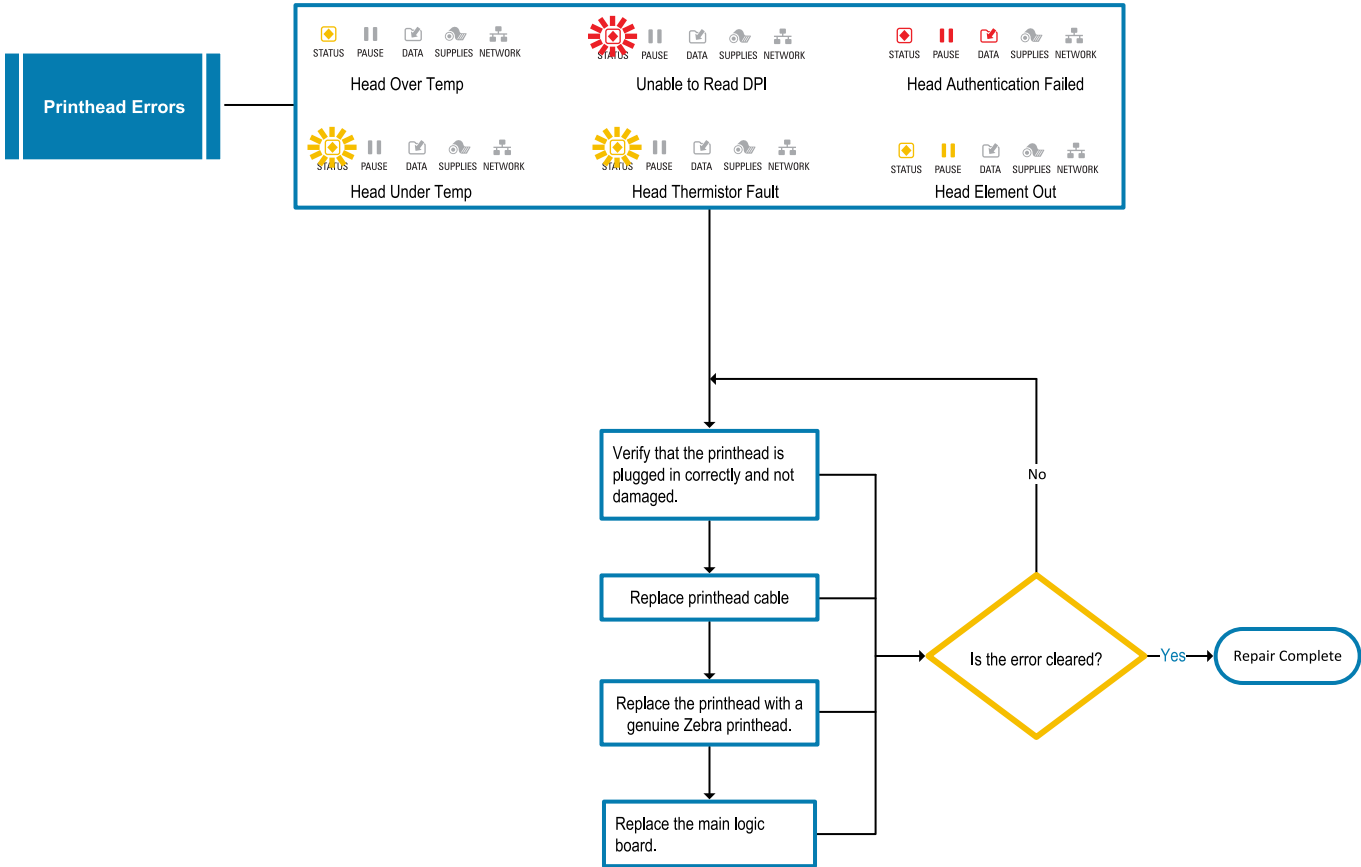

Cutter Errors

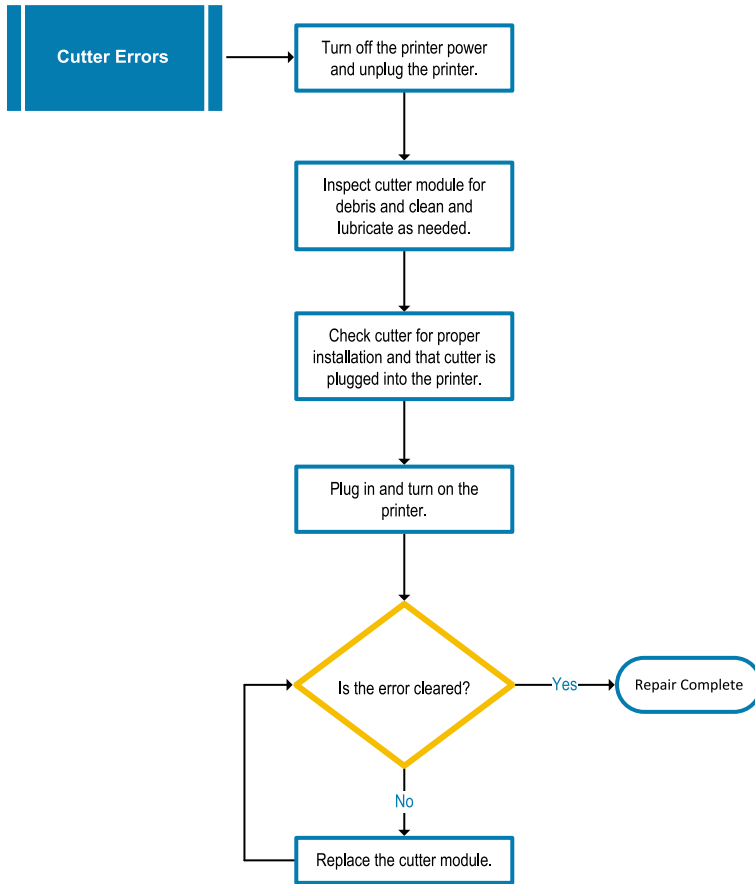

Wired Print Server Errors

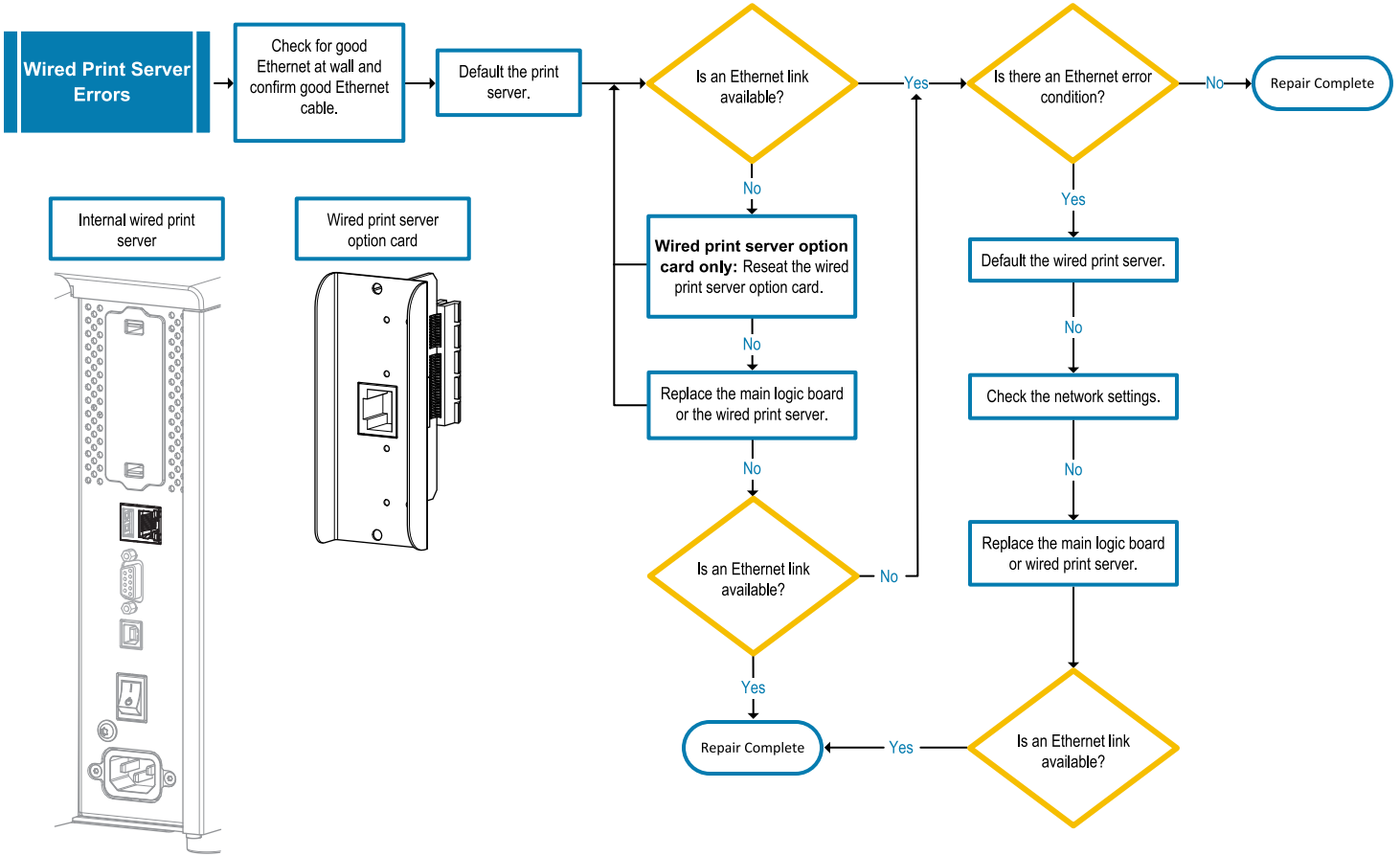

Wireless Print Server Errors

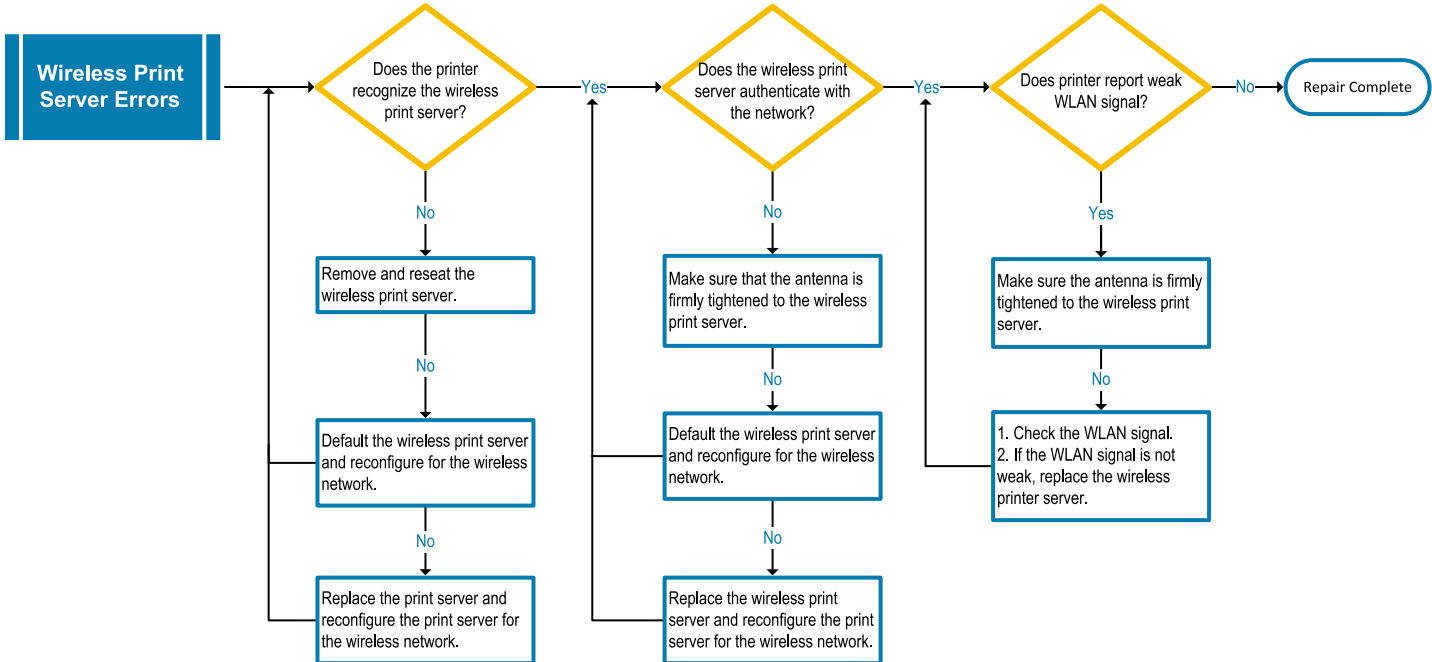

Servicing the Printer through Zebra Repair

If you cannot repair the printer and need assistance, go to <https://www.zebra.com/repair> to initiate a repair request and obtain a Return Material Authorization (RMA) number. You must include this number on the outside of the box when shipping the printer to Zebra.

Gather the following information before contacting Zebra:

- Serial number of the unit
- Model number or product name
- Firmware version number

Shipping the Printer

If you must ship the printer:

1. Turn off (O) the printer, and disconnect all cables.
2. Remove any media, ribbon, or loose objects from the printer interior.
3. Close the printhead.
4. Carefully pack the printer into the original container or a suitable alternate container to avoid damage during transit.

A shipping container can be purchased from Zebra if the original packaging has been lost or destroyed.



IMPORTANT: Zebra is not responsible for any damages incurred during shipment if an approved shipping container is not used. Shipping the units improperly can possibly void the warranty.

Diagnostic Tools, Tests, and Procedures

This section provides assorted diagnostic tools, tests, and procedures.

Indicator Lights

The indicator lights located at the top of the control panel communicate the printer's status.

Table 2 Status of Printer As Shown by Indicator Lights

























Indicator Lights	What they indicate
     STATUS PAUSE DATA SUPPLIES NETWORK STATUS light steady green (other lights steady yellow for 2 seconds during printer power-up).	The printer is ready.
     STATUS PAUSE DATA SUPPLIES NETWORK PAUSE light steady yellow.	The printer is paused.
     STATUS PAUSE DATA SUPPLIES NETWORK STATUS light steady red. SUPPLIES light steady red.	The media supply is out. The printer needs attention and cannot continue without user intervention.
     STATUS PAUSE DATA SUPPLIES NETWORK STATUS light steady red. SUPPLIES light flashing red.	The ribbon supply is out. The printer needs attention and cannot continue without user intervention.
     STATUS PAUSE DATA SUPPLIES NETWORK STATUS light steady yellow. SUPPLIES light flashing yellow.	The printer is in Direct Thermal mode, which does not require ribbon; however, ribbon is installed in the printer.

Table 2 Status of Printer As Shown by Indicator Lights (Continued)



















Indicator Lights	What they indicate
 <p>STATUS PAUSE DATA SUPPLIES NETWORK</p> <p>STATUS light steady red. PAUSE light steady yellow.</p>	<p>The printhead is open. The printer needs attention and cannot continue without user intervention.</p>
 <p>STATUS PAUSE DATA SUPPLIES NETWORK</p> <p>STATUS light steady yellow.</p>	<p>The printhead is over temperature.</p> <p> CAUTION—HOT SURFACE: The printhead may be hot and could cause severe burns. Allow the printhead to cool.</p>
 <p>STATUS PAUSE DATA SUPPLIES NETWORK</p> <p>STATUS light flashing yellow.</p>	<p>Indicates one of the following:</p> <ul style="list-style-type: none"> The printhead is under temperature. <p> CAUTION: This display message can be incorrect. The printhead may be hot and could cause severe burns. Allow the printhead to cool.</p> <ul style="list-style-type: none"> The main logic board (MLB) or power supply is over temperature.
 <p>STATUS PAUSE DATA SUPPLIES NETWORK</p> <p>STATUS light steady red. PAUSE light steady red. DATA light steady red.</p>	<p>The printhead was replaced with one that is not a genuine Zebra printhead. Install a genuine Zebra printhead to continue.</p>
 <p>STATUS PAUSE DATA SUPPLIES NETWORK</p> <p>STATUS light flashing red.</p>	<p>The printer is unable to read the dpi setting of the printhead.</p>
 <p>STATUS PAUSE DATA SUPPLIES NETWORK</p> <p>STATUS light steady red.</p>	<p>This indicates an error with the cutter. The cutter blade is in the media path.</p> <p> CAUTION: The cutter blade is sharp. Do not touch or rub the blade with your fingers.</p>
<p>Printers with a ZebraNet wired Ethernet option</p>	
 <p>STATUS PAUSE DATA SUPPLIES NETWORK</p> <p>NETWORK light off.</p>	<p>No Ethernet link is available.</p>
 <p>STATUS PAUSE DATA SUPPLIES NETWORK</p> <p>NETWORK light steady green.</p>	<p>A 100 Base-T link was found.</p>

Table 2 Status of Printer As Shown by Indicator Lights (Continued)

Indicator Lights	What they indicate
 <p>STATUS PAUSE DATA SUPPLIES NETWORK NETWORK light steady yellow.</p>	<p>A 10 Base-T link was found.</p>
 <p>STATUS PAUSE DATA SUPPLIES NETWORK NETWORK light steady red.</p>	<p>An Ethernet error condition exists. The printer is not connected to your network.</p>
<p>Printers with a ZebraNet wireless option</p>	
 <p>STATUS PAUSE DATA SUPPLIES NETWORK</p> <p style="text-align: center;">↓</p>  <p>STATUS PAUSE DATA SUPPLIES NETWORK</p> <p style="text-align: center;">↓</p>  <p>STATUS PAUSE DATA SUPPLIES NETWORK</p> <p>NETWORK light off.</p> <p>The light flashes red while the printer associates with the network.</p> <p>The light then flashes yellow while the printer is authenticating with the network.</p>	<p>A radio was found during power-up. The printer is attempting to associate with the network.</p>
 <p>STATUS PAUSE DATA SUPPLIES NETWORK NETWORK light steady green.</p>	<p>The radio is associated with your network and authenticated, and the WLAN signal is strong.</p>
 <p>STATUS PAUSE DATA SUPPLIES NETWORK NETWORK light flashing green.</p>	<p>The radio is associated with your network and authenticated, but the WLAN signal is weak.</p>
 <p>STATUS PAUSE DATA SUPPLIES NETWORK NETWORK light steady red.</p>	<p>A WLAN error condition exists. The printer is not connected to your network.</p>

Configuration Labels

Two of the most commonly used printer diagnostic items are the printer and network configuration labels. Analyzing the information on these labels can help you to troubleshoot potential issues.

To print these labels, do the following:

1. Turn off (O) the printer.
2. Press and hold **CANCEL** while turning on (I) the printer. Hold **CANCEL** until the first control panel light turns off.

The printer prints a printer configuration label and then a network configuration label as shown in these examples.

Figure 9 Sample Printer Configuration Label

PRINTER CONFIGURATION	
Zebra Technologies ZTC Z1XXX-203dpi ZPL XXXXXX-XX-XXXX	
10.....	LCD CONTRAST
+10.....	DARKNESS
2.0 IPS.....	PRINT SPEED
+000.....	TEAR OFF
TEAR OFF.....	PRINT MODE
BAR/NOTCH.....	MEDIA TYPE
REFLECTIVE.....	SENSOR SELECT
832.....	PRINT WIDTH
1422.....	LABEL LENGTH
39.0in 988mm.....	PRINT HEAD ID
NOT CONNECTED.....	MAXIMUM LENGTH
BIDIRECTIONAL.....	USB COMM.
RS232.....	PARALLEL COMM.
2400.....	SERIAL COMM.
8 BITS.....	BAUD
NONE.....	DATA BITS
XON/XOFF.....	PARITY
NONE.....	HOST HANDSHAKE
NORMAL MODE.....	PROTOCOL
<~> 7EH.....	COMMUNICATIONS
<^> 5EH.....	CONTROL PREFIX
<.> 2CH.....	FORMAT PREFIX
ZPL II.....	DELIMITER CHAR
CALIBRATION.....	ZPL MODE
CALIBRATION.....	MEDIA POWER UP
DEFAULT.....	HEAD CLOSE
+000.....	BACKFEED
DISABLED.....	LABEL TOP
020.....	LEFT POSITION
024.....	REPRINT MODE
255.....	WEB SENSOR
027.....	MEDIA SENSOR
027.....	TAKE LABEL
102.....	MARK SENSOR
000.....	MARK MED SENSOR
100.....	TRANS GAIN
050.....	TRANS BASE
OPCSWFXM.....	TRANS LED
.....	MARK LED
832 8/MM FULL.....	MODES ENABLED
V72.18.1ZP15107 <-	MODES DISABLED
1.3.....	RESOLUTION
6.4.1 255.....	FIRMWARE
NONE.....	XHL SCHEMA
12288k.....	HARDWARE ID
65536k.....	OPTION BOARD
NONE.....	RAM
FW VERSION.....	R: ONBOARD FLASH
02/29/12.....	E: FORMAT CONVERT
DISABLED.....	IDLE DISPLAY
2.1.....	RTC DATE
READY.....	RTC TIME
15.110 IN.....	ZBI
15.110 IN.....	ZBI VERSION
15.110 IN.....	ZBI STATUS
38.378 CM.....	NONRESET CNTR
38.378 CM.....	RESET CNTR1
38.378 CM.....	RESET CNTR2
38.378 CM.....	NONRESET CNTR
38.378 CM.....	RESET CNTR1
38.378 CM.....	RESET CNTR2
FIRMWARE IN THIS PRINTER IS COPYRIGHTED	

Figure 10 Sample Network Configuration Label

Network Configuration	
Zebra Technologies ZTC Z1XXX-XXXdpi ZPL XXXXXXXXXXXXXX	
Wired.....	PRIMARY NETWORK
PrintServer.....	LOAD LAN FROM?
INTERNAL WIRED.....	ACTIVE PRINTSRVR
Wired*	
ALL.....	IP PROTOCOL
192.168.000.017....	IP ADDRESS
255.255.255.000....	SUBNET
192.168.000.254....	GATEWAY
000.000.000.000....	WINS SERVER IP
YES.....	TIMEDOUT CHECKING
300.....	TIMEDOUT VALUE
000.....	ARP INTERVAL
9100.....	BASE RAW PORT
9200.....	JSDN CONFIG PORT
Wireless	
ALL.....	IP PROTOCOL
000.000.000.000....	IP ADDRESS
255.255.255.000....	SUBNET
000.000.000.000....	GATEWAY
000.000.000.000....	WINS SERVER IP
YES.....	TIMEDOUT CHECKING
300.....	TIMEDOUT VALUE
000.....	ARP INTERVAL
9100.....	BASE RAW PORT
9200.....	JSDN CONFIG PORT
INSERTED.....	CARD INSERTED
02dfh.....	CARD MFG ID
9134H.....	CARD PRODUCT ID
ac:3f:a4:b2:05:9c...	MAC ADDRESS
YES.....	DRIVER INSTALLED
INFRASTRUCTURE.....	OPERATING MODE
125.....	ESSID
1.0.....	CURRENT TX RATE
OPEN.....	WEP TYPE
WPA PSK.....	WLAN SECURITY
1.....	WEP INDEX
000.....	PODR SIGNAL
LONG.....	PREAMBLE
NO.....	ASSOCIATED
ON.....	PULSE ENABLED
15.....	PULSE RATE
OFF.....	INTL MODE
USA/CANADA.....	REGION CODE
USA/CANADA.....	COUNTRY CODE
0x7FF.....	CHANNEL MASK
Bluetooth	
4.3.1p1.....	FIRMWARE
02/13/2015.....	DATE
on.....	DISCOVERABLE
3.0/4.0.....	RADIO VERSION
on.....	ENABLED
AC:3F:A4:B2:05:9D...	MAC ADDRESS
76J1627008B6.....	FRIENDLY NAME
no.....	CONNECTED
1.....	MIN SECURITY MODE
no.....	CONN SECURITY MODE
supported.....	IOS
FIRMWARE IN THIS PRINTER IS COPYRIGHTED	

PAUSE Self Test

This self test can be used to provide the test labels required when making adjustments to the printer's mechanical assemblies or to determine if any printhead elements are not working.

The following shows a sample printout.

Figure 11 PAUSE Test Label

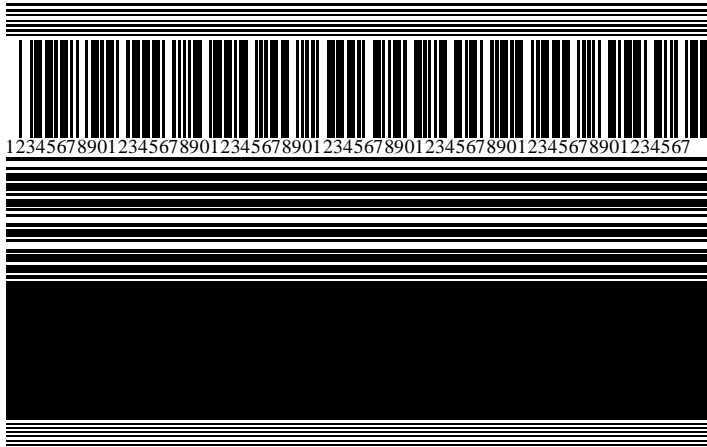

1. Turn off (O) the printer.
2. Press and hold **PAUSE** while turning on (I) the printer. Hold **PAUSE** until the first control panel light turns off.

The initial self test prints 15 labels at the printer's slowest speed, and then automatically pauses the printer. Each time **PAUSE** is pressed, an additional 15 labels print.

While the printer is paused:

- Pressing **CANCEL** alters the self test. Each time **PAUSE** is pressed, 15 labels print at 152 mm (6 in.) per second.
 - Pressing **CANCEL** again alters the self test a second time. Each time **PAUSE** is pressed, 50 labels print at the printer's slowest speed.
 - Pressing **CANCEL** again alters the self test a third time. Each time **PAUSE** is pressed, 50 labels print at 152 mm (6 in.) per second.
 - Pressing **CANCEL** again alters the self test a fourth time. Each time **PAUSE** is pressed, 15 labels print at the printer's maximum speed.
3. To exit this self test at any time, press and hold **CANCEL**.

Sensor Profile

Use the ~JG ZPL command to print a sensor profile. The image will extend across several actual labels or tags.

Use the sensor profile image to troubleshoot the following situations:

- The printer experiences difficulty in determining gaps (web) between labels.
- The printer incorrectly identifies preprinted areas on a label as gaps (web).
- The printer cannot detect ribbon.

Compare your results to the examples shown in this section. If the sensitivity of the sensors must be adjusted, calibrate the printer. (See [Calibrating the Ribbon and Media Sensors](#) on page 35.)

Ribbon Sensor Profile

The line labeled RIBBON (1) on the sensor profile indicates the ribbon sensor readings. The ribbon sensor threshold setting is indicated by OUT (2). If the ribbon readings are below the threshold value, the printer does not acknowledge that ribbon is loaded.

Figure 12 Sensor Profile (Ribbon Section)

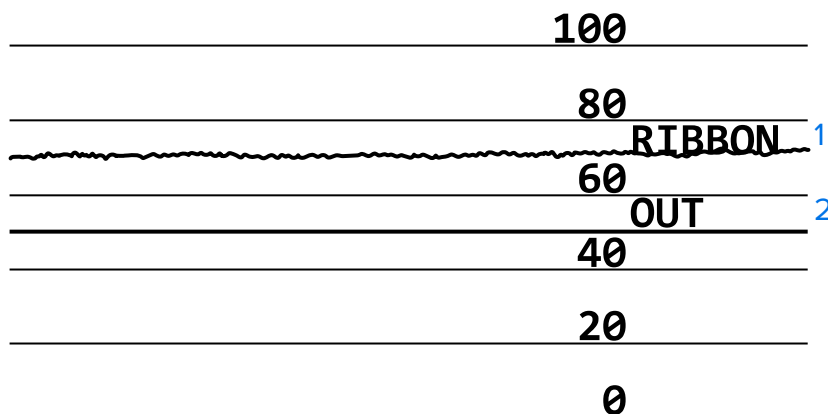

Media Sensor Profile

The line labeled MEDIA (1) on the sensor profile indicates the media sensor readings. The media sensor threshold settings are indicated by WEB (2). The media out threshold is indicated by OUT (3). The upward or downward spikes (4) indicate divisions between labels (the web, notch, or black mark), and the lines between the spikes (5) indicate where labels are located.

If you compare the sensor profile printout to a length of your media, the spikes should be the same distance apart as the gaps on the media. If the distances are not the same, the printer may be having difficulty determining where the gaps are located.

Figure 13 Media Sensor Profile (Gap/Notch Media)

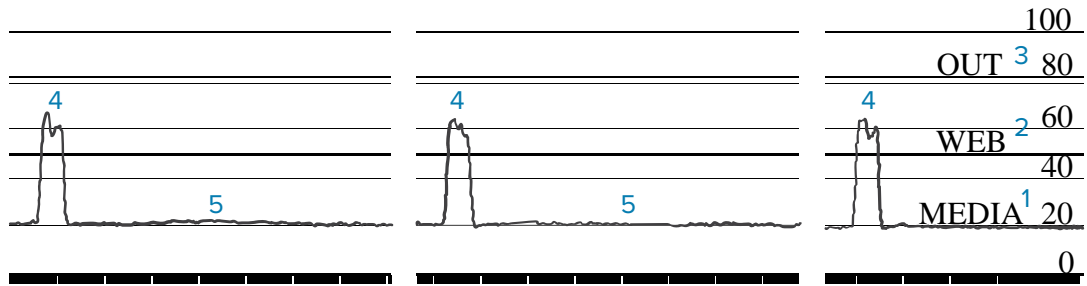
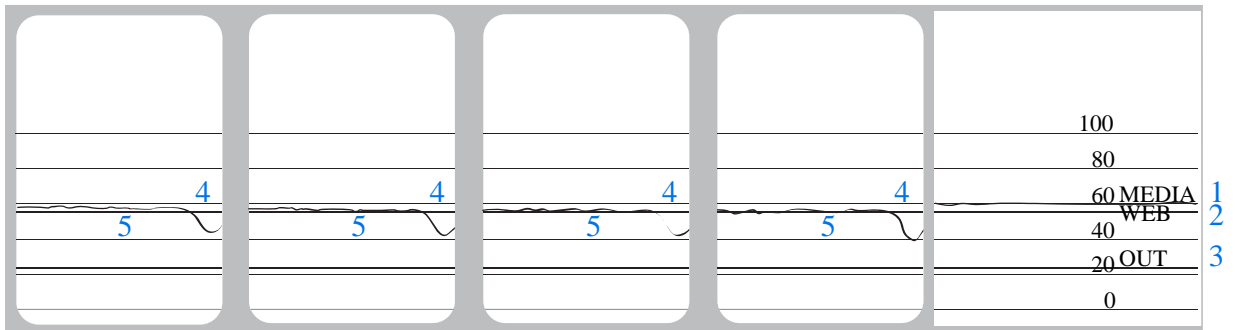

Figure 14 Media Sensor Profile (Black Mark Media)



Communication Diagnostics Test

The communication diagnostics test is a troubleshooting tool for checking the interconnection between the printer and the host computer. When the printer is in diagnostics mode, it prints all data received from the host computer as straight ASCII characters with the hex values below the ASCII text. The printer prints all characters received, including control codes such as CR (carriage return). Here is an example of a typical test label from this test.



NOTE: The test label prints upside-down.

Figure 15 Communications Diagnostics Test Label

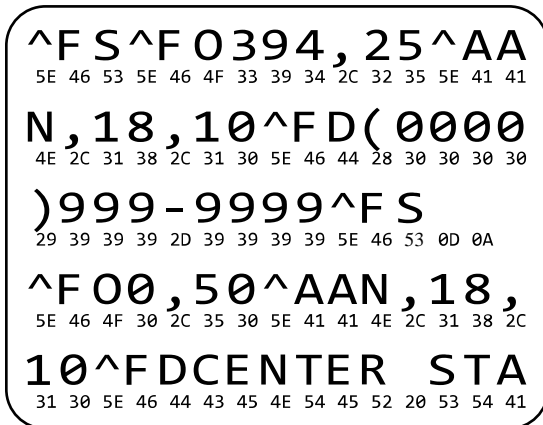

1. Set the print width equal to or less than the label width being used for the test. See the [User Guide](#) for instructions.
2. Set the **DIAGNOSTICS MODE** option to **ENABLED**. See the [User Guide](#) for instructions.
The printer enters diagnostics mode and prints any data received from the host computer on a test label.
3. Check the test label for error codes. For any errors, check that your communication parameters are correct.
Errors show on the test label as follows:
 - FE indicates a framing error.
 - OE indicates an overrun error.
 - PE indicates a parity error.
 - NE indicates noise.
4. Turn the printer off (O) and then back on (I) to exit this self test and return to normal operation.

Loading Defaults or Last Saved Values

Restoring the printer to default values or to the last saved values can help if things are not working as expected.

FACTORY	Restores all printer settings other than the network settings back to the factory defaults. Use care when loading defaults because you will need to reload all settings that you changed manually.
NETWORK	Reinitializes the printer's wired or wireless print server. With a wireless print server, the printer also reassociates with your wireless network.
LAST SAVED	Loads settings from the last permanent save.

How to Load Defaults or Last Saved Values

ZPL command(s):	<p>FACTORY: ^JUF</p> <p>NETWORK: ^JUN</p> <p>LAST SAVED: ^JUR</p>
Control panel key(s):	<p>FACTORY: Hold FEED + PAUSE during printer power-up to reset the printer parameters to factory values.</p> <p>NETWORK: Hold CANCEL + PAUSE during printer power-up to reset the network parameters to factory values.</p> <p>LAST SAVED: N/A</p>
Printer web page:	<p>FACTORY: View and Modify Printer Settings > Restore Default Configuration</p> <p>NETWORK: Print Server Settings > Reset Print Server</p> <p>LAST SAVED: View and Modify Printer Settings > Restore Saved Configuration</p>

Calibrating the Ribbon and Media Sensors

Printer calibration adjusts the sensitivity of the media and ribbon sensors. It also helps ensure proper alignment of the image being printed and optimal print quality.

Perform calibration in the following situations:

- You switched to a different size or type of ribbon or media.
- The printer experiences any of the following issues:
 - skips labels
 - the printed image wanders/drifts either side to side or up and down
 - ribbon is not being detected when it is installed or when it runs out
 - non-continuous labels are being treated as continuous

Performing Auto Calibration

You can set the printer to perform an auto calibration (**CALIBRATE**) or a short calibration (**SHORT CAL**) using the **POWER UP ACTION** or **HEAD CLOSE ACTION** parameters.

- **CALIBRATE**—Adjusts sensor levels and thresholds, determines the label length, and feeds the media to the next web.
- **SHORT CAL**—Sets the media and web thresholds without adjusting sensor gain, determines the label length, and feeds the media to the next web.

See the [User Guide](#) for more information about the **POWER UP ACTION** and **HEAD CLOSE ACTION** parameters.

Performing Manual Calibration

You may need to manually calibrate the printer if you see issues with the print output.

1. On the control panel, press and hold **PAUSE** and **CANCEL** for 2 seconds.

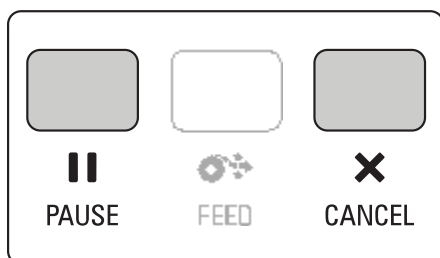

The status and pause lights flash yellow once. Then the pause light blinks yellow.

2. Release the printhead assembly.

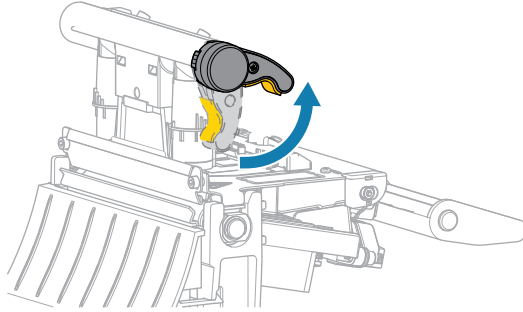

As the printhead lever rotates upward, the printhead assembly pivots upward.

3. Extend the media approximately 150 mm (6 in.) out of the printer, and then remove the exposed labels so that only the liner remains.

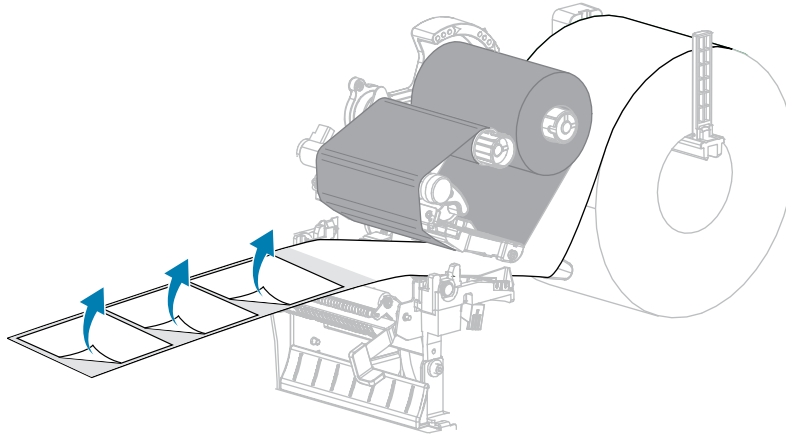

4. Pull the media into the printer so that only the backing is between the media sensors.

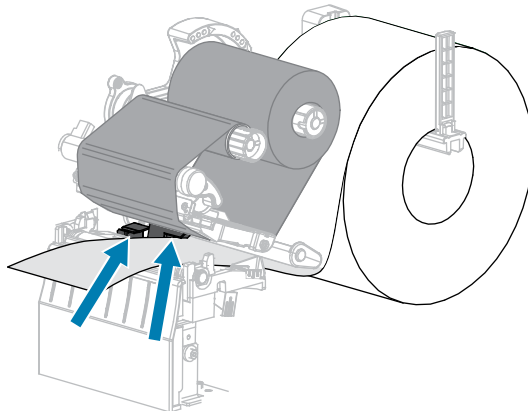

5. Move the ribbon (if used) to the right, away from the sensors.

6. Close the printhead assembly.

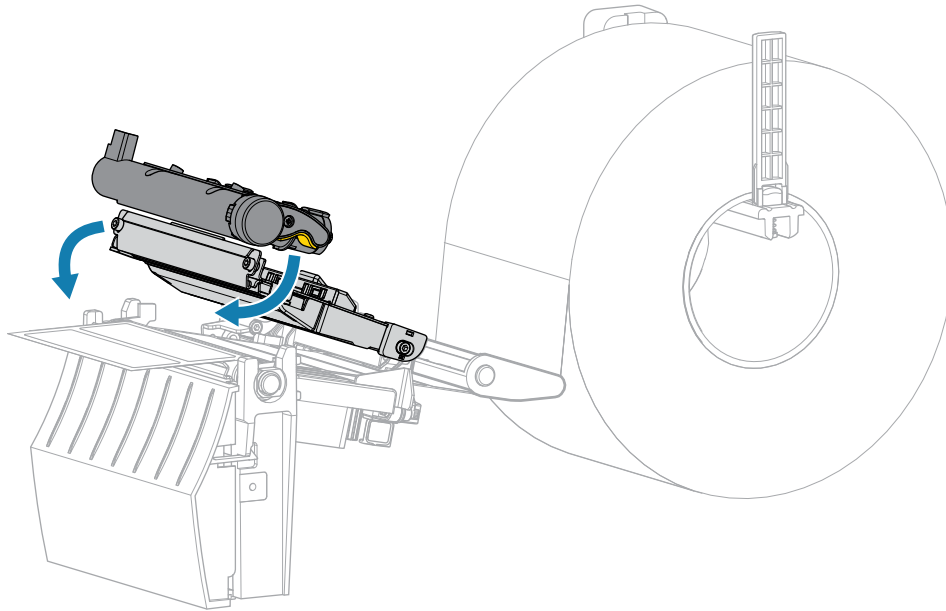

7. Press **II PAUSE** to begin calibration.

The pause light turns off, and the supplies light flashes yellow. The process is complete when the supplies light turns off and the pause light turns yellow.

8. Release the printhead assembly.

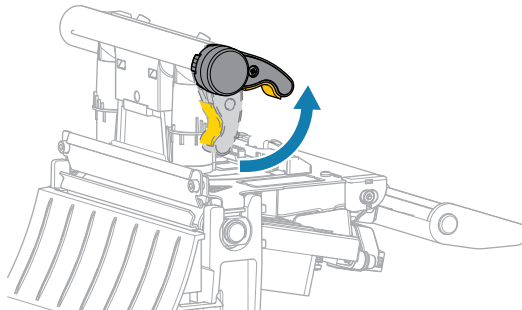

As the printhead lever rotates upward, the printhead assembly pivots upward.

9. Reload the ribbon (if used) by moving it to the left and straightening it, and turn the ribbon take-up spindle to take up the slack.
10. Pull the media forward until a label is positioned between the sensors.

11. Close the printhead assembly.

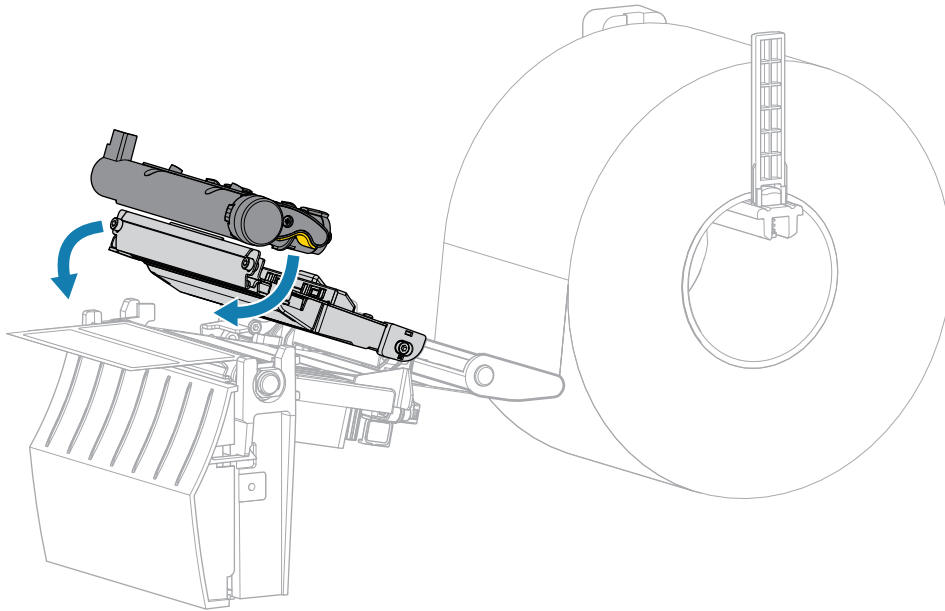

12. Press **PAUSE** to complete calibration.
The supplies light flashes yellow. The process is complete when the supplies light turns off and the pause light turns yellow.
13. Press **PAUSE** again to enable printing.
14. Press **FEED** to verify that a label feeds to the correct position.

Routine Maintenance

This section provides routine cleaning and maintenance procedures.

Cleaning Schedule and Procedures

Routine preventive maintenance is a crucial part of normal printer operation. By taking good care of your printer, you can minimize the potential problems that you might have with it and help to achieve and to maintain your standards for print quality.

Over time, the movement of media or ribbon across the printhead wears through the protective ceramic coating, exposing and eventually damaging the print elements (dots). To avoid abrasion:

- Clean the printhead frequently.
- Minimize printhead pressure and burn temperature (darkness) settings by optimizing the balance between the two.
- When using Thermal Transfer mode, ensure that the ribbon is as wide or wider than the media to prevent exposing the printhead elements to the more abrasive label material.



IMPORTANT: Zebra is not responsible for damage caused by the use of cleaning fluids on this printer.

Specific cleaning procedures are provided on the following pages. This table shows the recommended cleaning schedule. These intervals are intended as guidelines only. You may have to clean more often, depending upon your application and media.

Table 3 Recommended Cleaning Schedule

Area	Method	Interval
Printhead	Solvent*	Direct Thermal Mode: After every roll of media (or 500 feet of fanfold media). Thermal Transfer Mode: After every roll of ribbon.
Platen roller	Solvent*	
Media sensors	Air blow	
Ribbon sensor	Air blow	
Media path	Solvent*	
Ribbon path	Solvent*	
Pinch roller (part of Peel-Off option)	Solvent*	

Table 3 Recommended Cleaning Schedule (Continued)

Area		Method	Interval
Cutter module	If cutting continuous, pressure-sensitive media	Solvent*	After every roll of media (or more often, depending upon your application and media).
	If cutting tag stock or label liner material	Solvent* and air blow	After every two or three rolls of media.
Tear-off/peel-off bar		Solvent*	Once a month.
Take-label sensor		Air blow	Once every six months.

* Zebra recommends using Preventive Maintenance Kit (part number 47362). In place of the Preventive Maintenance Kit, you may use a lint-free cloth dipped in 99.7% isopropyl alcohol.

Cleaning the Exterior, the Media Compartment, and the Sensors

Over time, dust, grime, and other debris may build up on the outside and inside of your printer, particularly in a harsh operating environment.

Printer Exterior

You may clean the exterior surfaces of the printer with a lint-free cloth and a small amount of a mild detergent, if necessary. Do not use harsh or abrasive cleaning agents or solvents.



IMPORTANT:

Zebra is not responsible for damage caused by the use of cleaning fluids on this printer.

Media Compartment and Sensors

To clean the sensors:

1. Brush, air blow, or vacuum any accumulated paper lint and dust away from the media and ribbon paths.
2. Brush, air blow, or vacuum any accumulated paper lint and dust away from the sensors.

Cleaning the Printhead and Platen Roller

Inconsistent print quality, such as voids in the barcode or graphics, may indicate a dirty printhead. For the recommended cleaning schedule, see [Table 3 Recommended Cleaning Schedule](#) on page 39.



CAUTION—PRODUCT DAMAGE: For printers with a peel assembly, keep the peel assembly closed while cleaning the platen roller to reduce the risk of bending the tear-off/peel-off bar.



CAUTION—ESD: Before touching the printhead assembly, discharge any built-up static electricity by touching the metal printer frame or by using an anti-static wriststrap and mat.

1. Open the media cover.

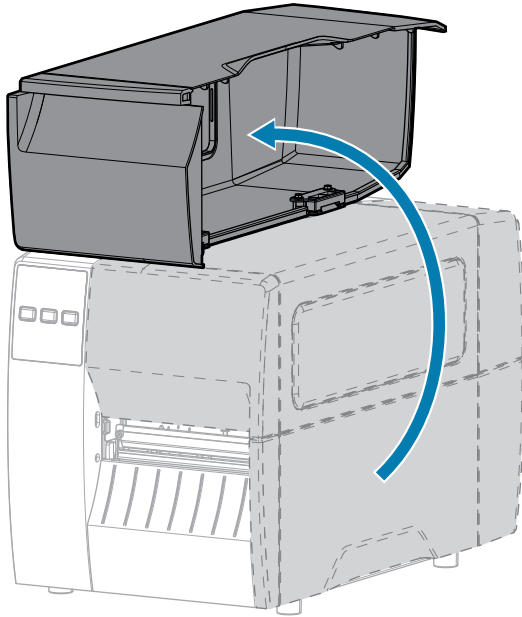

2. Release the printhead assembly.

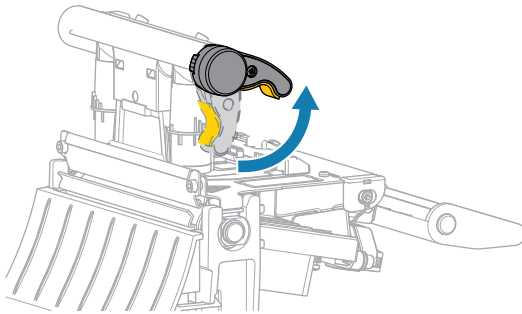

As the printhead lever rotates upward, the printhead assembly pivots upward.

3. Remove the ribbon (if used) and the media.
4. Using the swab from a Zebra Preventive Maintenance Kit, wipe along the brown strip on the printhead assembly from end to end. In place of the Preventive Maintenance Kit, you may use a clean swab dipped in 99.7% isopropyl alcohol. Allow the solvent to evaporate.



CAUTION—HOT SURFACE: The printhead may be hot and could cause severe burns. Allow the printhead to cool.

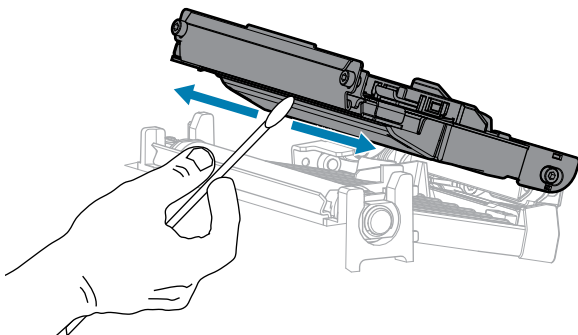

5. While manually rotating the platen roller, clean it thoroughly with the swab. Allow the solvent to evaporate.

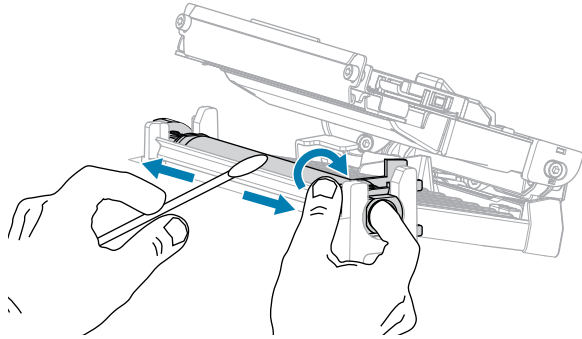

6. Reload the ribbon (if used) and the media. See the [User Guide](#) for instructions.
7. Close the printhead assembly.

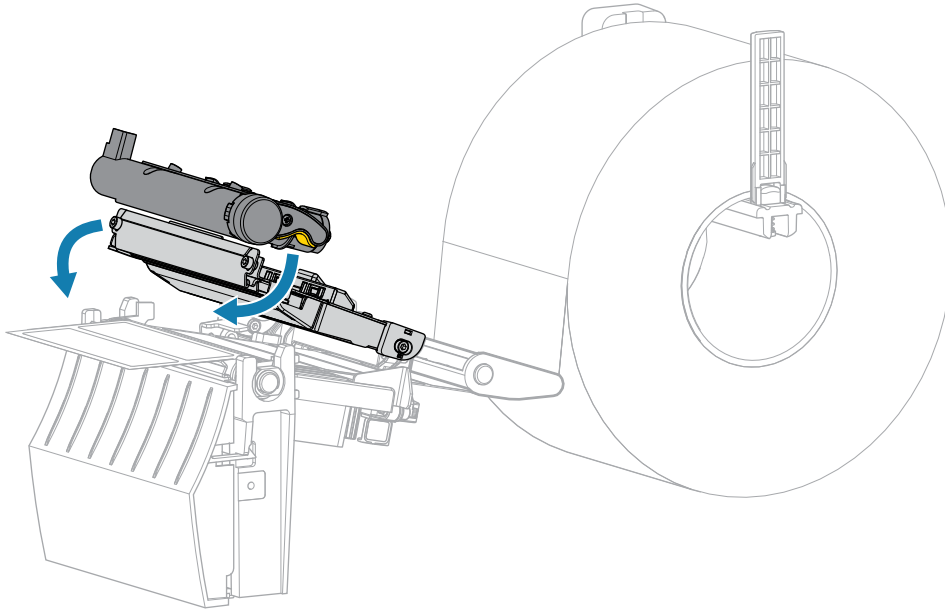

8. Close the media cover.

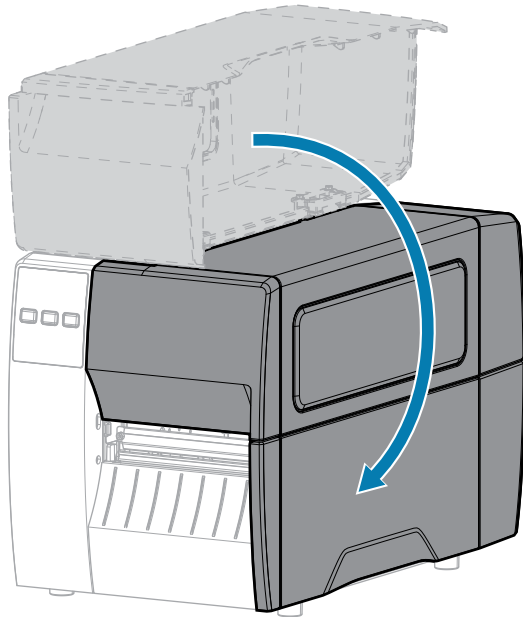

9. Press **PAUSE** to exit pause mode and enable printing.

The printer may perform a label calibration or feed a label, depending on your settings.



NOTE: If performing this procedure does not improve print quality, try cleaning the printhead with Save-A-Printhead cleaning film. This specially coated material removes contamination buildup without damaging the printhead. Call your authorized Zebra reseller for more information.

Cleaning the Peel Assembly

The peel assembly consists of several spring-loaded rollers to ensure the proper roller pressure. Clean the pinch roller and tear-off/peel-off bar if adhesive buildup begins to affect peel performance.



CAUTION: Do not use your left hand to assist in closing the Peel assembly. The top edge of the Peel roller/assembly could pinch your fingers.

If adhesive buildup affects peel-off performance, complete these steps.

1. Open the media cover.

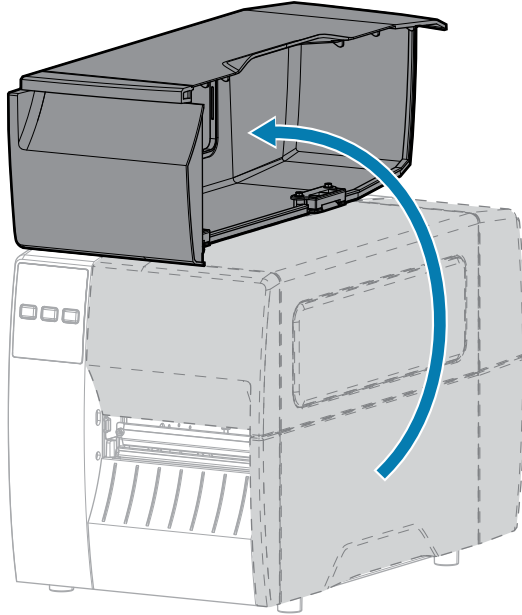

CAUTION: The printhead may be hot and could cause severe burns. Allow the printhead to cool.

2. Release the printhead assembly.

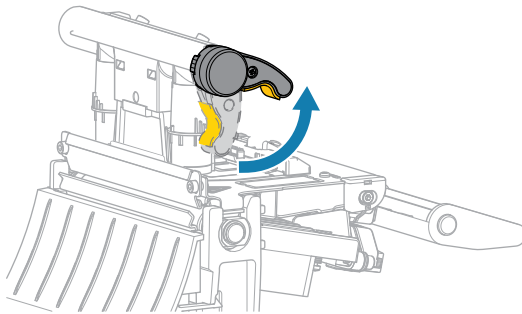

As the printhead lever rotates upward, the printhead assembly pivots upward.

3. Push down the peel-off mechanism release lever to open the peel assembly.

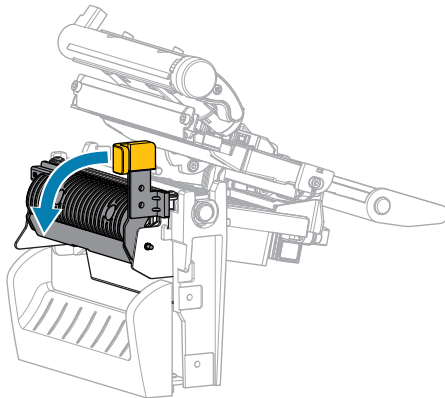

4. Remove any media liner to expose the pinch roller.

5. While manually rotating the pinch roller, clean it thoroughly with the swab from the Preventive Maintenance Kit (part number 47362). In place of the Preventive Maintenance Kit, you may use a clean swab dipped in 99.7% isopropyl alcohol. Allow the solvent to evaporate.

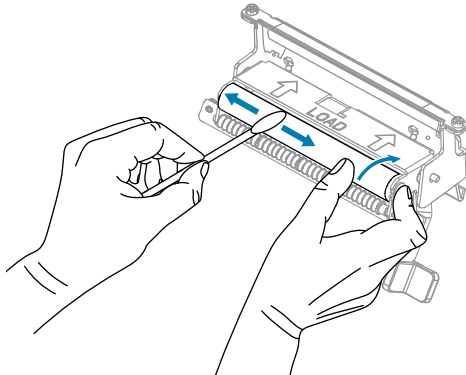

6. Use the swab to remove excess adhesive from the tear-off/peel-off bar. Allow the solvent to evaporate.



CAUTION—PRODUCT DAMAGE: Apply minimum force when cleaning the tear-off/peel-off bar. Excessive force can cause the tear-off/peel-off bar to bend, which could have a negative effect on peel performance.

7. Reload the media liner through the peel mechanism. See the [User Guide](#) for instructions.
8. Close the peel assembly using the peel-off mechanism release lever.



CAUTION: Use the peel-off mechanism release lever and your right hand to close the peel assembly. Do not use your left hand to assist in closing. The top edge of the peel roller/assembly could pinch your fingers.

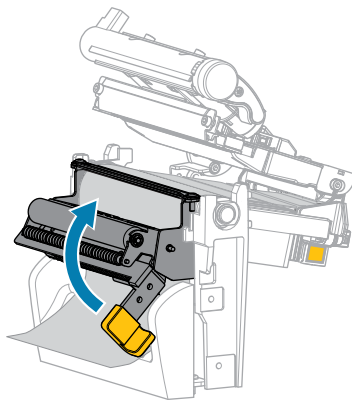

9. Close the printhead assembly.

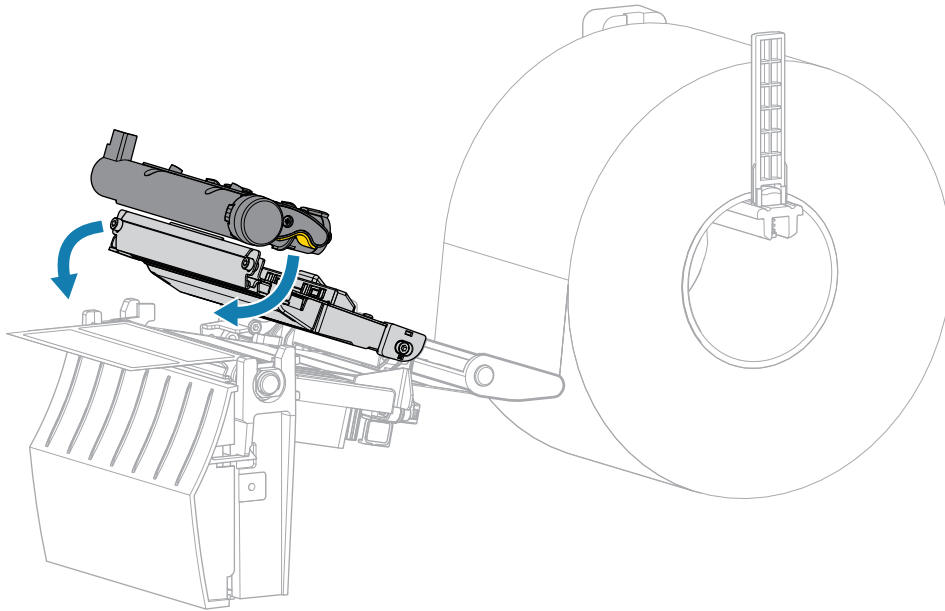

10. Close the media cover.

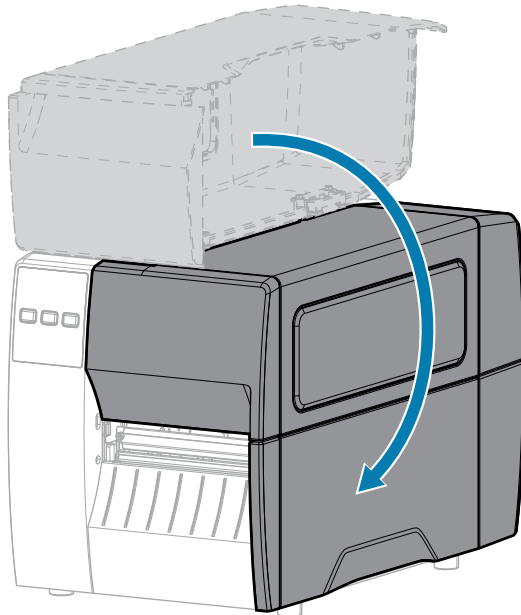

11. Press **PAUSE** to exit pause mode and enable printing.

The printer may perform a label calibration or feed a label, depending on your settings.

Cleaning and Lubricating the Cutter Module

If the cutter is not cutting the labels cleanly or if it jams with labels, clean the cutter.



CAUTION: For personnel safety, always power off and unplug the printer before performing this procedure.

1. Open the media cover.

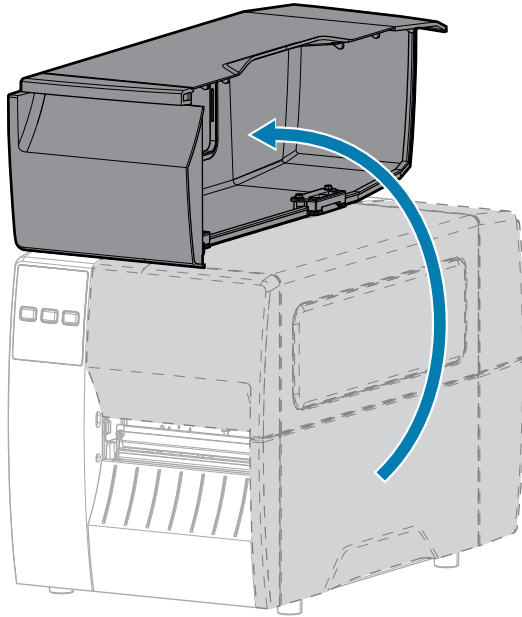

2. Turn off (O) the printer and disconnect the AC power cord.
3. Remove media that is loaded through the cutter module.
4. Loosen and remove the thumbscrew and lock washer on the cutter shield.



CAUTION: The cutter blade is sharp. Do not touch or rub the blade with your fingers.

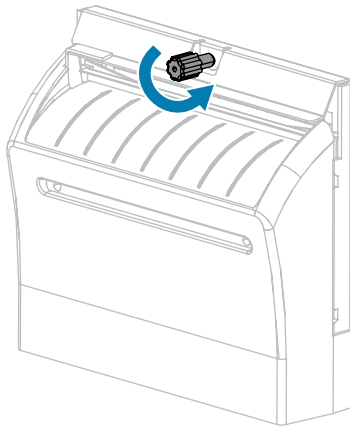

5. Remove the cutter shield.

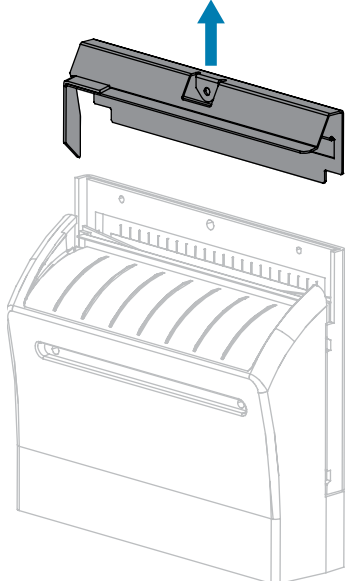

6. If necessary, rotate the cutter motor thumbscrew to fully expose the V-shaped cutter blade (1).

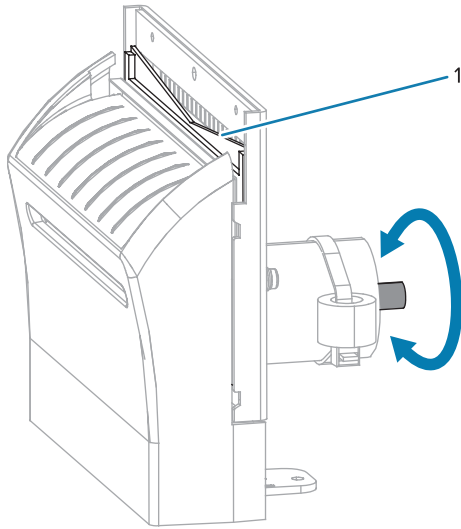

Routine Maintenance

7. Using the swab from the Preventive Maintenance Kit (part number 47362), wipe along the upper cutting surface and the cutter blade. In place of the Preventive Maintenance Kit, you may use a clean swab dipped in 90% isopropyl alcohol. Allow the solvent to evaporate.

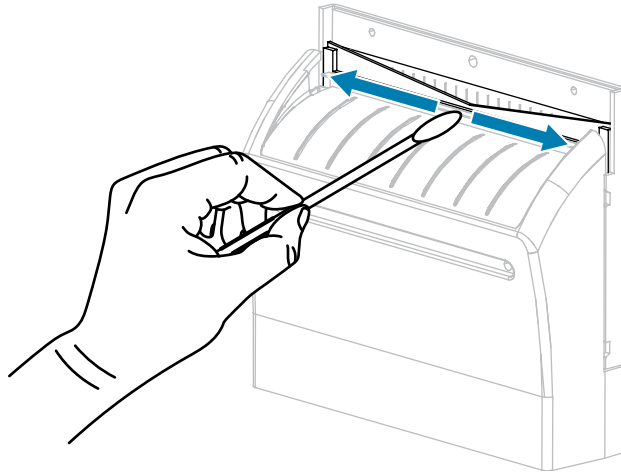

8. When the solvent has evaporated, soak a clean swab in a general-purpose, higher-viscosity silicone or PTFE oil lubricant.

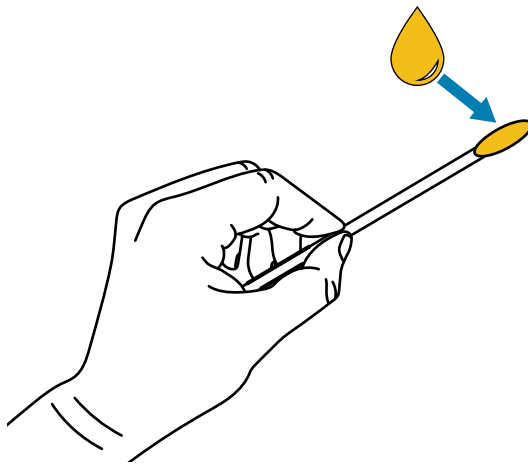

9. Apply an even layer along all exposed surfaces of both cutter blades. Remove any excess oil so that none of it comes in contact with the printhead or platen roller.

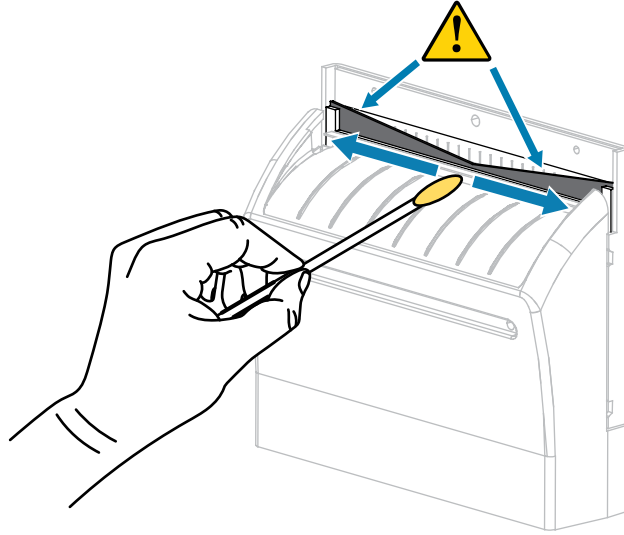

CAUTION: The cutter blade is sharp. For operator safety, replace the cutter shield.

10. Replace the cutter shield and secure it with the thumbscrew and lock washer that you removed earlier.

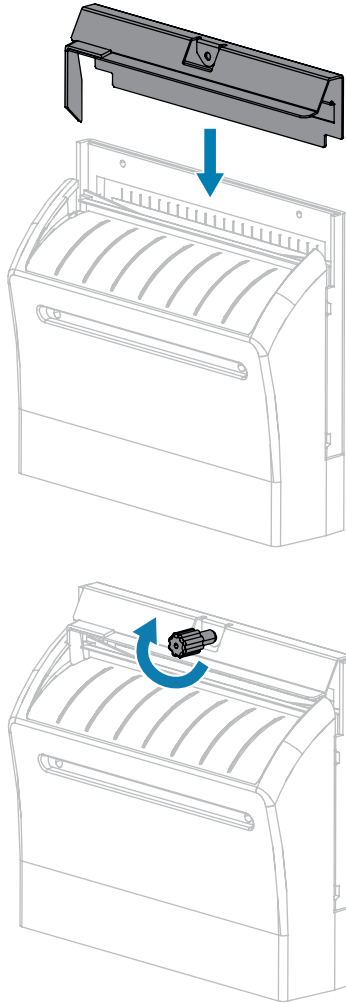

11. Close the media cover.

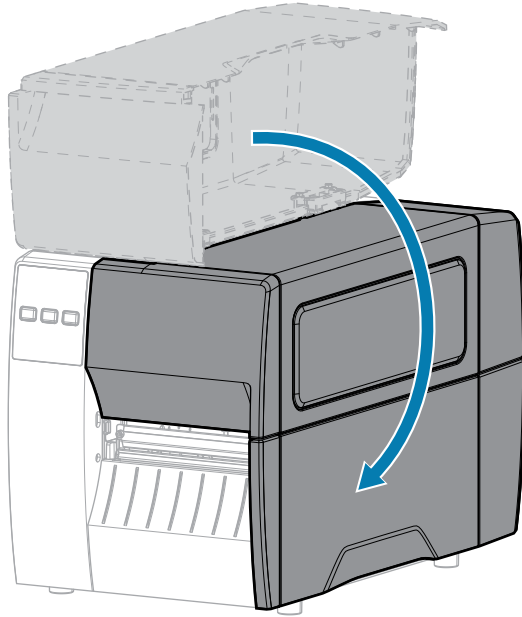

12. Plug the printer into its power source, and then turn on (I) the printer.
The cutter blade returns to its operating position.
13. If the cutter continues to perform unsatisfactorily, contact an authorized service technician.

Removing Used Ribbon

Remove used ribbon from the ribbon take-up spindle each time you change the roll of ribbon.

1. Has the ribbon run out?

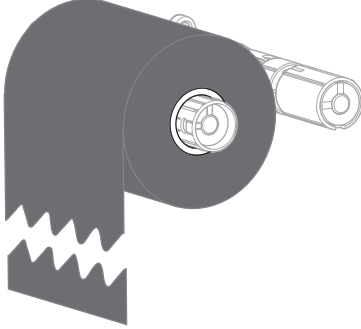
If...	Then...
Ran out	Continue with the next step.
Did not run out	<ol style="list-style-type: none"> a. Cut or break the ribbon before the ribbon take-up spindle.  <ol style="list-style-type: none"> b. Continue with the next step.

2. Slide the core with the used ribbon off of the ribbon take-up spindle.

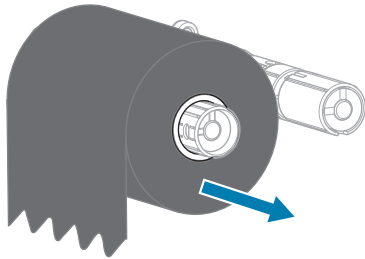

3. Discard the used ribbon. You may reuse the empty core from the ribbon supply spindle by moving it to the ribbon take-up spindle.
4. Reload the ribbon.

Replacing Printer Components

Some printer components, such as the printhead and platen roller, may wear out over time and can be replaced easily. Regular cleaning may extend the life of some of these components.

For more information on recommended cleaning intervals, see [Cleaning Schedule and Procedures](#) on page 39.

Ordering Replacement Parts

For optimal printing quality and proper printer performance across our product line, Zebra strongly recommends the use of genuine Zebra supplies as part of the total solution. Specifically, the ZT111 printers are designed to work only with genuine Zebra printheads, thus maximizing safety and print quality.

Contact your authorized Zebra reseller for part ordering information.

Recycling Printer Components



The majority of this printer's components are recyclable. The printer's main logic board may include a battery that you should dispose of properly.

Do not dispose of any printer components in unsorted municipal waste. Please dispose of the battery according to your local regulations, and recycle the other printer components according to your local standards. For more information, see zebra.com/environment.

Lubrication

The only lubrication needed for this printer is for the cutter module. Follow the instructions in [Cleaning and Lubricating the Cutter Module](#) on page 46. Do not lubricate any other parts of the printer.



CAUTION: Some commercially available lubricants will damage the finish and the mechanical parts if used on this printer.

Replacement Parts and Options

This section lists the maintenance and option kits for this printer. For kit instructions, go to <https://www.zebra.com/service-docs>.

Outer Casing

For kit instructions, go to <https://www.zebra.com/service-docs>.

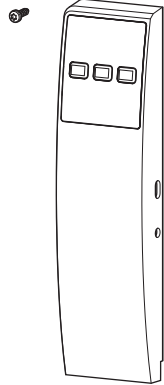
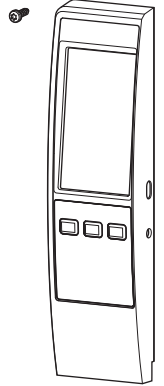
Description	Zebra Part Number	Kit Contents
Control Panel ZT111	P1123335-001	
Control Panel ZT211CN China Models	P1123335-002	
Control Panel ZT211TL	P1123335-003	
Control Panel ZT211IN India Models	P1123335-004	
Control Panel ZT231	P1123335-005	
Control Panel ZT231CN China Models	P1123335-006	
Control Panel ZT231IN India Models	P1123335-051	

Replacement Parts and Options

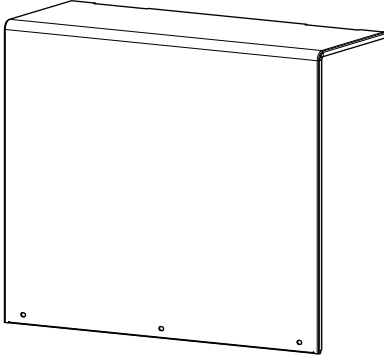
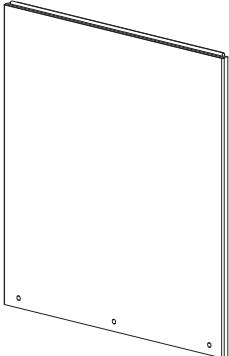
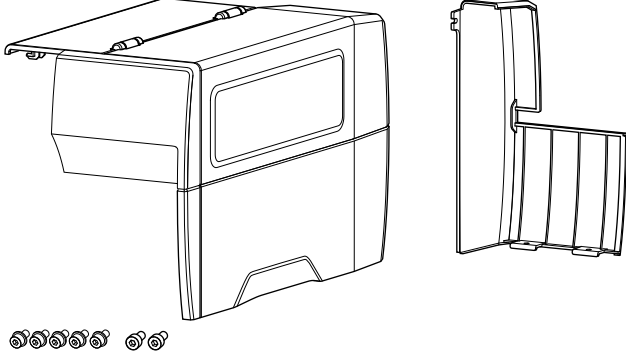
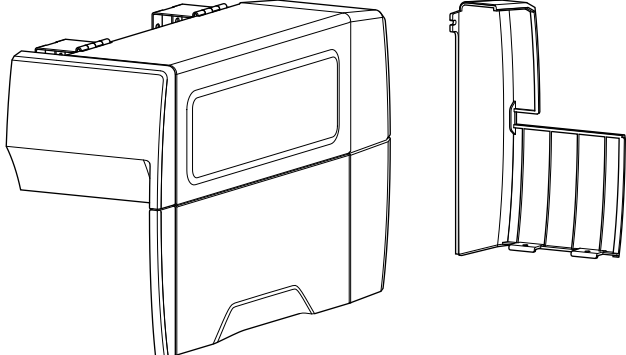
Description	Zebra Part Number	Kit Contents
Electronics Cover ZT211, ZT231	P1037974-034	
Electronics Cover ZT111	P1037990-005	
Media Cover ZT111	P1123335-007	
Media Cover ZT211, ZT231	P1123335-008	

Replacement Parts and Options

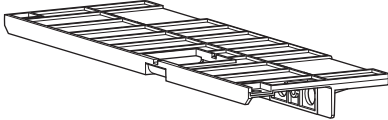
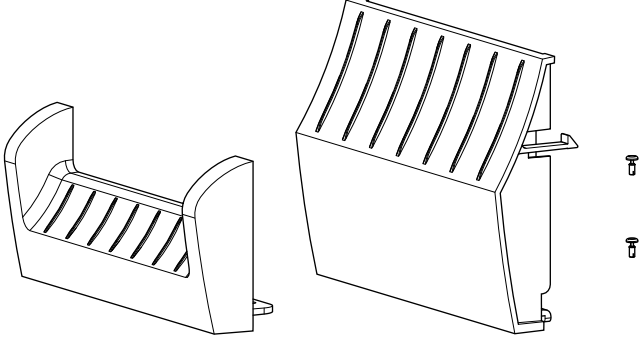
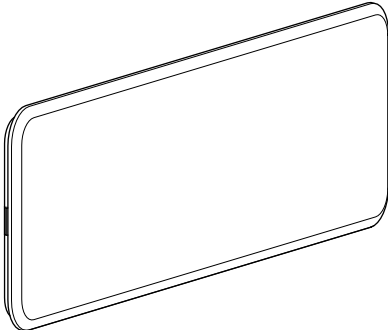
Description	Zebra Part Number	Kit Contents
Structural Top Plate ZT211, ZT231	P1123335-009	
Front Lower Panels ZT111, ZT211, ZT231 (includes tear and peel panels)	P1123335-010	
Media Window ZT111, ZT211, ZT231	P1123335-011	

Print Mechanism

For kit instructions, go to <https://www.zebra.com/service-docs>.

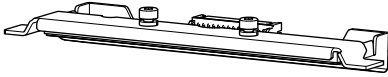
Description	Zebra Part Number	Kit Contents
Printhead 203 dpi ZT111, ZT211, ZT231	P1123335-012 Being replaced with P1123335-052	
Printhead 300 dpi ZT111, ZT211, ZT231	P1123335-013 Being replaced with P1123335-053	

Replacement Parts and Options

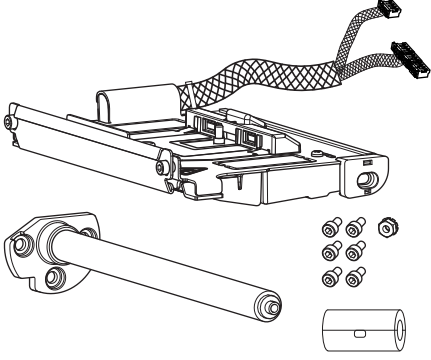
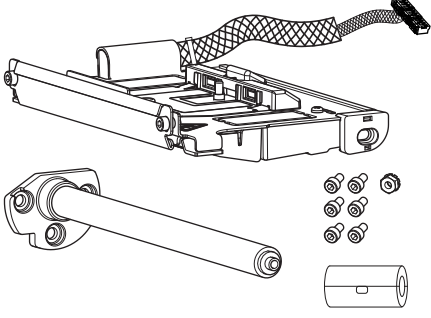
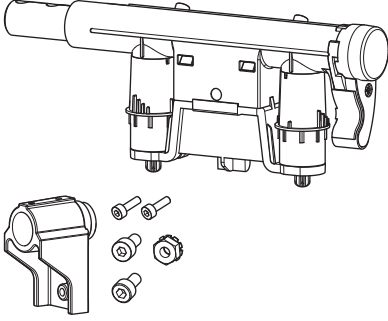
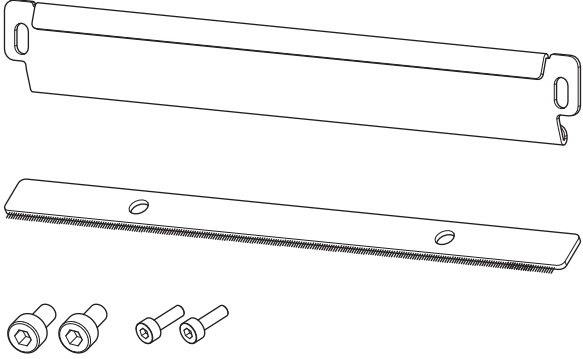
Description	Zebra Part Number	Kit Contents
Thermal Transfer Print Mechanism ZT111, ZT211, ZT231 (includes ribbon sensor with cable, printhead cables and ground contact)	P1123335-014	
Direct Thermal Print Mechanism ZT111, ZT211, ZT231 (includes printhead cables and ground contact)	P1123335-015	
Toggle Bar ZT111, ZT211, ZT231	P1123335-016	
Ribbon Strip Plate and Ribbon Static Brush ZT111, ZT211, ZT231	P1037974-066	

Replacement Parts and Options

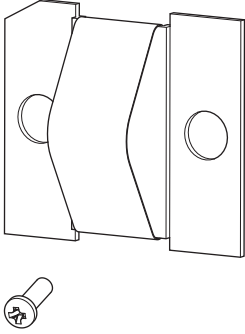
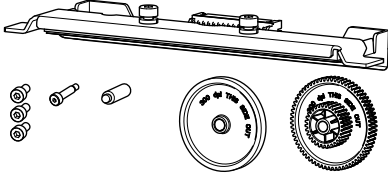
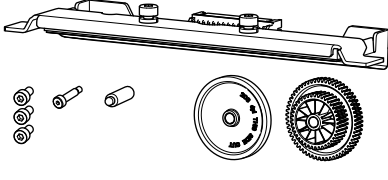
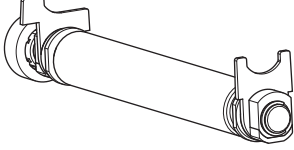
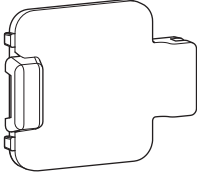
Description	Zebra Part Number	Kit Contents
Ground Contact ZT111, ZT211, ZT231	P1037974-015	 <p>The diagram shows three rectangular components with circular cutouts, likely representing the ground contact parts. Below them is a single screw with a Phillips head.</p>
Convert 203 dpi to 300 dpi ZT111, ZT211, ZT231	P1123335-017	 <p>The diagram shows a long metal bar with various components. Below it are several small parts: three screws, a small pin, a larger pin, a circular gear with '300 DPI' markings, and another circular gear with '203 DPI' markings.</p>
Convert 300 dpi to 203 dpi ZT111, ZT211, ZT231	P1123335-018	 <p>The diagram shows a long metal bar with various components. Below it are several small parts: three screws, a small pin, a larger pin, a circular gear with '203 DPI' markings, and another circular gear with '300 DPI' markings.</p>
Platen Roller ZT111, ZT211, ZT231	P1037974-028	 <p>The diagram shows a long, cylindrical roller with a handle-like structure at one end and a mounting bracket at the other.</p>
Cover for Platen Roller Access	P1123335-019	 <p>The diagram shows a rectangular cover with a handle on the left side and a notch on the right side, designed to fit around the platen roller.</p>

Electronics



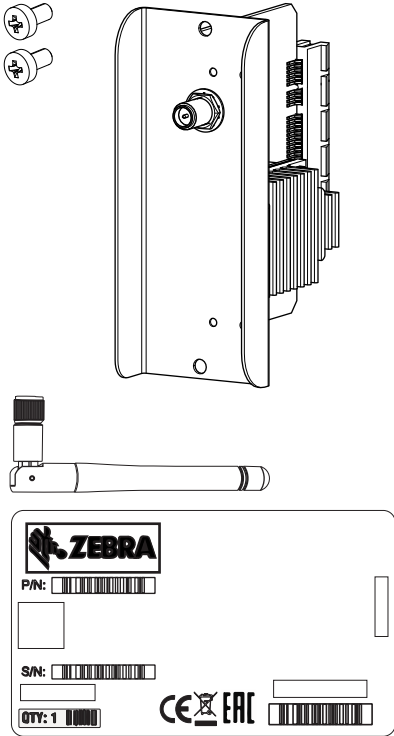
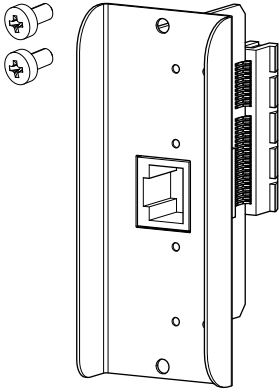

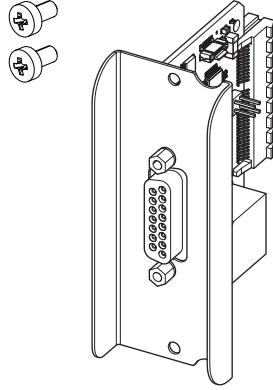
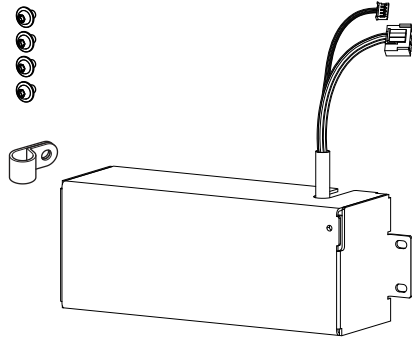
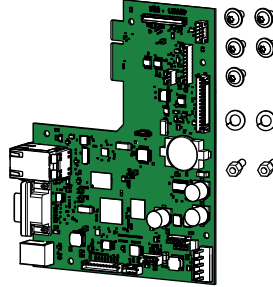
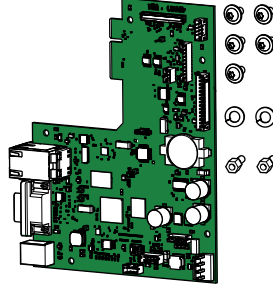

For kit instructions, go to <https://www.zebra.com/service-docs>.

Description	Zebra Part Number	Kit Contents
ZebraNet Internal Wireless 802.11ac WiFi, USA & Canada, ZT111, ZT211, ZT231	P1083320-037A	 <p>The diagram shows the kit contents for the ZebraNet Internal Wireless 802.11ac WiFi kit. It includes two screws, a small antenna, and a Zebra label with the following information: ZEBRA logo, P/N: [barcode], S/N: [barcode], QTY: 1, and CE EAC certification marks.</p>
ZebraNet Internal Wireless 802.11ac WiFi, Japan, ZT111, ZT211, ZT31	P1083320-037B	
ZebraNet Internal Wireless 802.11ac, For all countries except USA, Canada or Japan, ZT111, ZT211, ZT231	P1083320-037C	
Ethernet Card ZT111, ZT211, ZT231	P1123335-035	 <p>The diagram shows the kit contents for the Ethernet Card ZT111, ZT211, ZT231 kit. It includes two screws and the Ethernet card itself.</p>

Replacement Parts and Options

Description	Zebra Part Number	Kit Contents
Applicator Interface, ZT231 only	P1123335-025	
Power Supply ZT231	P1123335-022	
Power Supply ZT111, ZT211	P1123335-023	
Main Logic Board, ZT231	P1123335-020	
Main Logic Board, ZT111, ZT211	P1123335-021	

Replacement Parts and Options

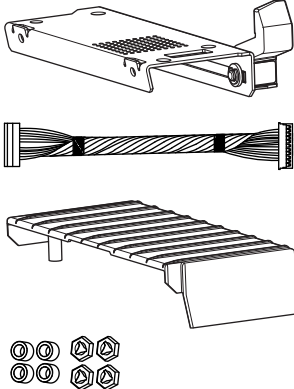
Description	Zebra Part Number	Kit Contents
RFID Module, USA and Canada, ZT231 only	P1123335-026A	
RFID Module, Japan, ZT231 only	P1123335-026B	
RFID Module, All Countries Except USA, Canada & Japan, ZT231 only	P1123335-026C	 <p>The kit for P1123335-026C includes four screws, a Zebra RFID module, and a label with the following information: ZEBRA P/N:  @ 2 #12 S/N: 01  Bundle Number: 08  23100221 QTY: 1 CE EAC</p>
Replacement WiFi Antenna for 802.11ac Radio	P1037974-053	
Replacement RFID Hardware, ZT231 only	P1123335-027	 <p>The kit for P1123335-027 includes a main RFID hardware unit, a cable, a metal shield, and four screws.</p>

Replacement Parts and Options

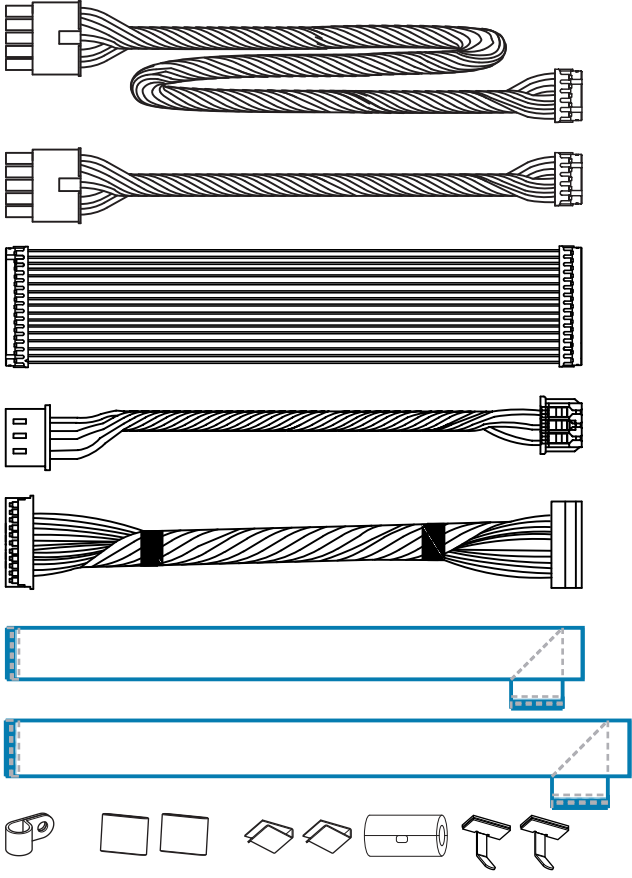
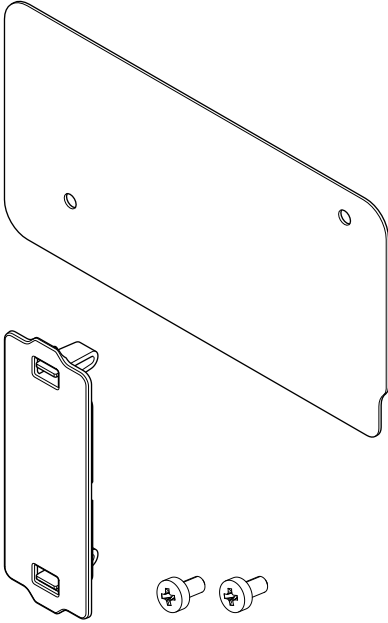
Description	Zebra Part Number	Kit Contents
<p>Electronics Cables (includes electronics used throughout printer), ZT111, ZT211, ZT231</p>	<p>P1123335-028</p>	 <p>The diagram shows the following components:</p> <ul style="list-style-type: none"> Two long, braided cables with multi-pin connectors at both ends. A flat ribbon cable with multiple parallel lines. A shorter braided cable with a multi-pin connector on one end and a different connector on the other. A braided cable with a multi-pin connector on one end and a different connector on the other, secured with two black bands. Two long, thin blue flexible cables with connectors at one end. A collection of small components: a roll of tape, two square covers, two small rectangular pieces, a roll of material, and two small metal brackets.
<p>Covers for Electronic Options ZT111, ZT211, ZT231</p>	<p>P1123335-029</p>	 <p>The diagram shows the following components:</p> <ul style="list-style-type: none"> A large, white, trapezoidal cover plate with two circular holes. A smaller, white, rectangular cover plate with a notch on one side. Two screws with Phillips heads.

Sensors

For kit instructions, go to <https://www.zebra.com/service-docs>.

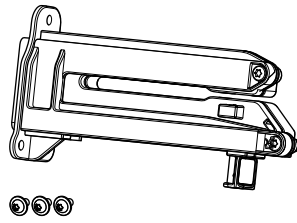
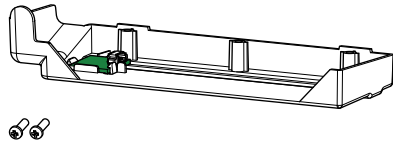
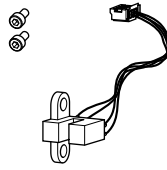
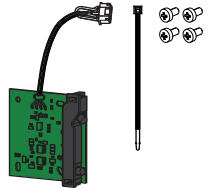
Description	Zebra Part Number	Kit Contents
Media Sensor ZT111, ZT211, ZT231	P1123335-030	
Ribbon Sensor ZT111, ZT211, ZT231	P1123335-031	
Head Open Sensor ZT111, ZT211, ZT231	P1123335-032	
Take Label Sensor ZT111, ZT211, ZT231	P1123335-033	

Drive System

For kit instructions, go to <https://www.zebra.com/service-docs>.

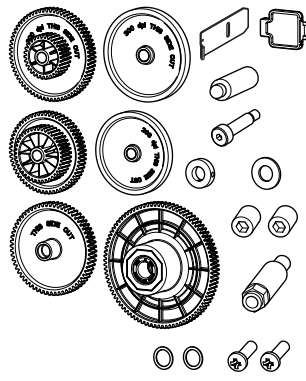
Description	Zebra Part Number	Kit Contents
Drive Gears (includes gears for 203 dpi and 300 dpi) ZT111, ZT211, ZT231	P1037974-061	

Replacement Parts and Options

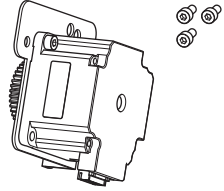
Description	Zebra Part Number	Kit Contents
Drive Motor for 203 dpi and 300 dpi ZT111, ZT211, ZT231	P1123335-034	

Media Path

For kit instructions, go to <https://www.zebra.com/service-docs>.

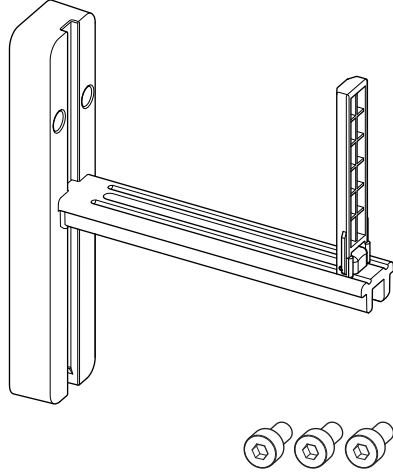
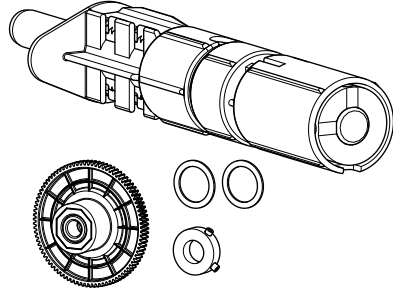
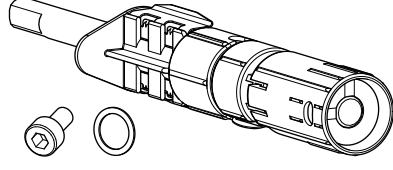
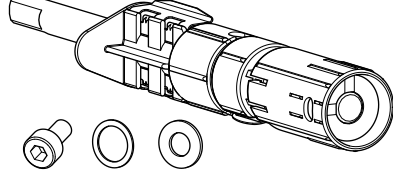
Description	Zebra Part Number	Kit Contents
Media Hanger ZT111, ZT211, ZT231	P1037974-027	
Ribbon Supply Spindle ZT111, ZT211, ZT231	P1037974-050	
Ribbon Take Up Spindle ZT111, ZT211, ZT231	P1037974-051	
Ribbon Supply Spindle for Ribbons Coated Inside ZT111, ZT211, ZT231	79830M	

Replacement Parts and Options

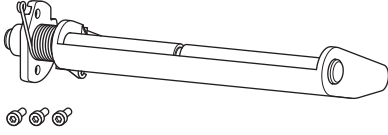
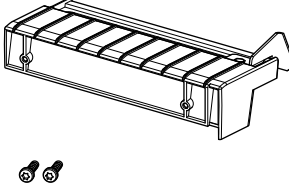
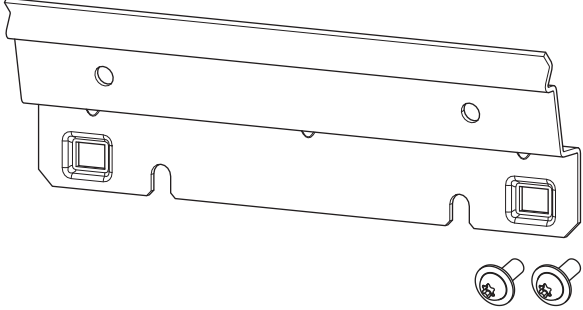
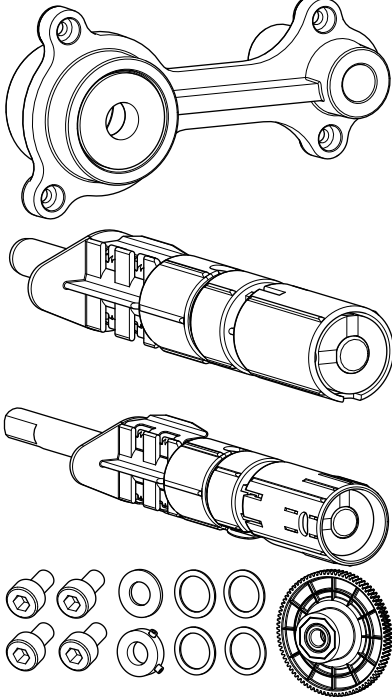
Description	Zebra Part Number	Kit Contents
Media Dancer ZT111, ZT211, ZT231	P1123335-036	
Media Guide ZT111, ZT211, ZT231	P1123335-037	
Tear Bar ZT111, ZT211, ZT231	P1123335-038	
Entire Ribbon System, ZT111, ZT211, ZT231 (Includes the bearing support and both ribbon spindles. The drive gears connecting the spindles to the motor are NOT included in this kit.)	P1123335-039	

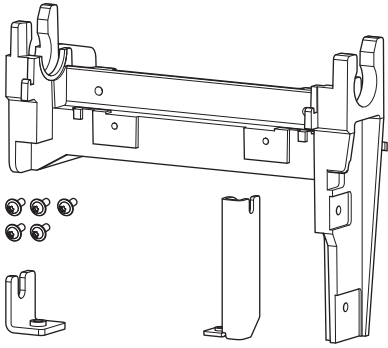
Description	Zebra Part Number	Kit Contents
Housing for Platen Roller ZT111, ZT211, ZT231	P1123335-040	

Media Handling Options

For kit instructions, go to <https://www.zebra.com/service-docs>.

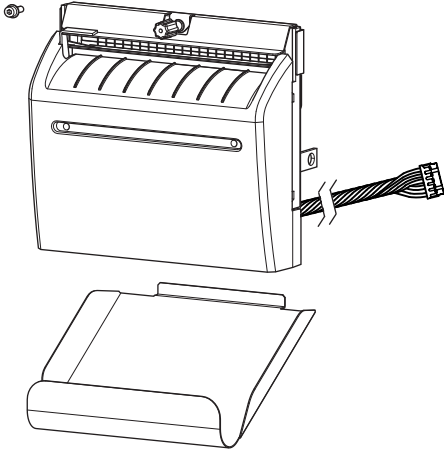
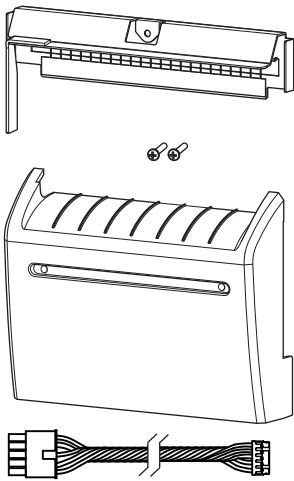
Description	Zebra Part Number	Kit Contents
Cutter Option ZT111, ZT211, ZT231	P1123335-041	
Cutter Cover with PCBA ZT111, ZT211, ZT231	P1123335-043	

Replacement Parts and Options

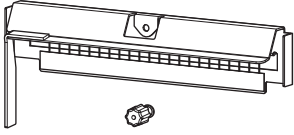
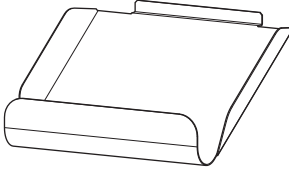
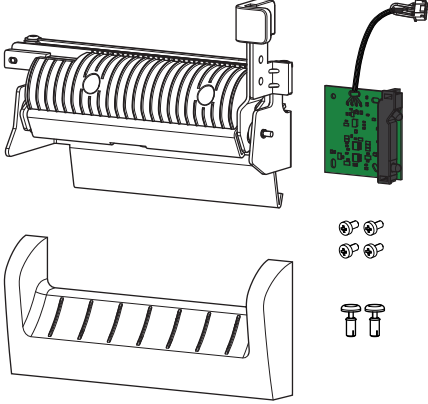
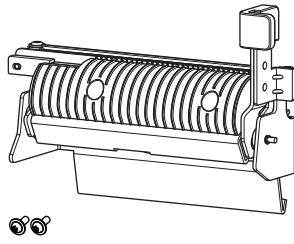
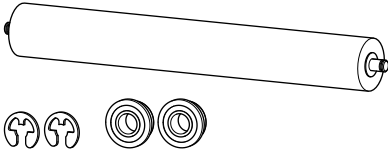
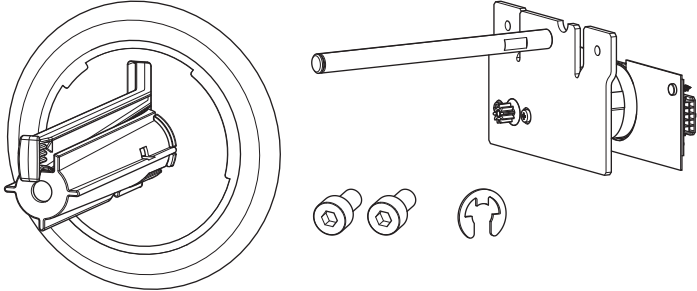
Description	Zebra Part Number	Kit Contents
Replacement Cutter Static Brush & Cutter Guard ZT111, ZT211, ZT231	P1037974-036	
Catch Tray for Cutter ZT111, ZT211, ZT231	P1037974-037	
Peel Option ZT111, ZT211, ZT231	P1123335-042	
Peel Assembly Unit ZT111, ZT211, ZT231	P1123335-044	
Roller for Peel Unit ZT111, ZT211, ZT231	P1037974-039	
Replacement LTU PCB with Drive Motor and Spindle ZT231 only	P1037974-040	

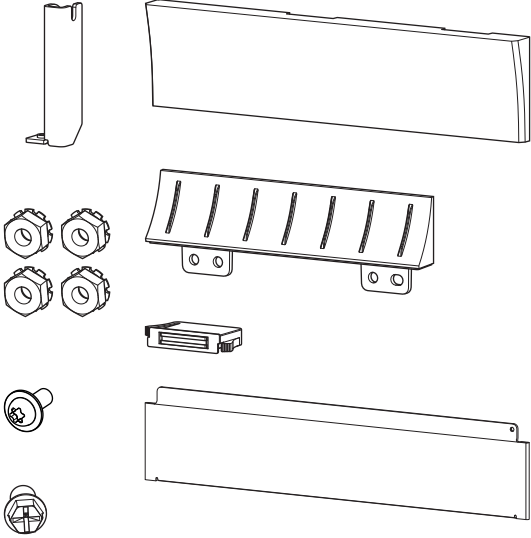
Description	Zebra Part Number	Kit Contents	
Door for LTU (Liner Take Up) ZT231 only	P1123335-045		

Hardware and Packaging

For kit instructions, go to <https://www.zebra.com/service-docs>.

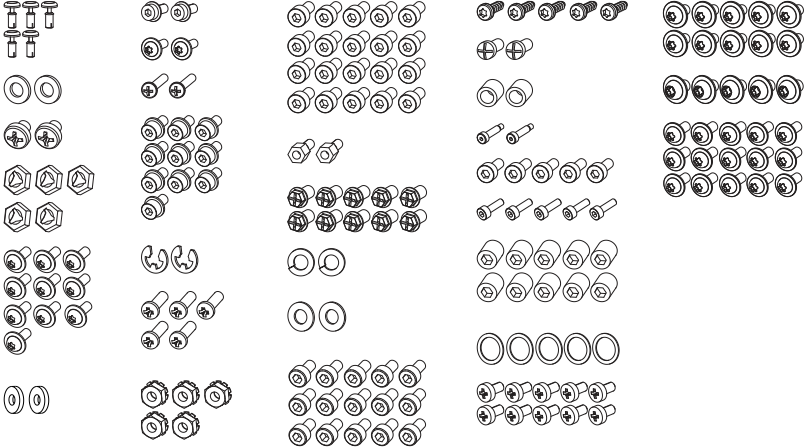
Description	Zebra Part Number	Kit Contents			
Assorted Hardware ZT111, ZT211, ZT231 (various screws, washers, and other parts used throughout the printer)	P1123335-048				

Replacement Parts and Options

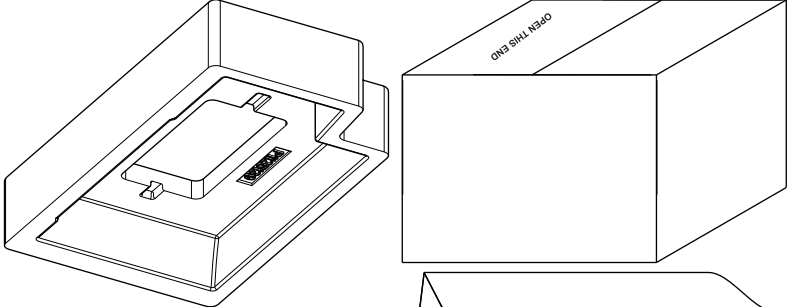
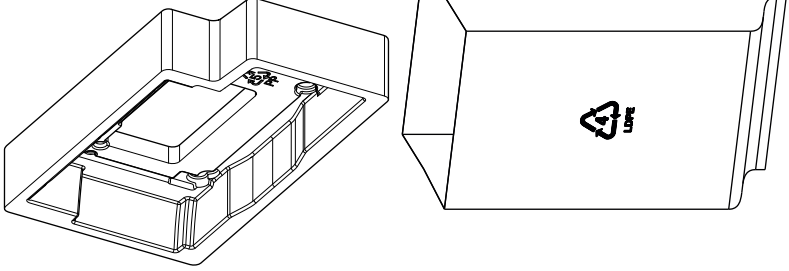
Description	Zebra Part Number	Kit Contents
Packaging for Shipping the Printer, ZT111, ZT211, ZT1231	P1123335-046	 <p>The diagram shows a printer unit placed inside a protective foam-lined tray. To the right of the tray is a rectangular cardboard shipping box with the text '019 0111 1240' printed on its top surface.</p>
Packaging for Shipping Printers with Liner Take-Up Option Installed, ZT1231	P1123335-047	 <p>The diagram shows a printer unit with a liner take-up option installed, housed within a larger foam-lined tray. To the right of the tray is a rectangular cardboard shipping box featuring a recycling symbol on its front panel.</p>

